

<http://laptopblue.vn/>

1

Page	Title of schematic page	Rev.	Date
01	Page List	1A	
02	Block Diagram	1A	
03	Change List	1A	
04	IVY 1/4 (HOST&PCIE)	1A	
05	IVY 2/4 (DDR3 I/F)	1A	
06	IVY 3/4 (POWER)	1A	
07	IVY 4/4 (GND/Strap)	1A	
08	PCH 1/6 (DMI/FDI/VIDEO)	1A	
09	PCH 2/6 (SATA/RTC/HDA/LPC)	1A	
10	PCH 3/6 (PCIE/USB/CLK/NV)	1A	
11	PCH 4/6 (GPIO/CPU/STRAP)	1A	
12	PCH 5/6 (POWER)	1A	
13	PCH 6/6 (GND)	1A	
14	DDR3 DIMM-0-STD	1A	
15	DDR3 DIMM-1-STD	1A	
16	WPCE985L & FLASH	1A	
17	LVDS/CAMERA	1A	
18	CARD READER (RTS5209)	1A	
19	HDMI/THERMAL	1A	
20	USB	1A	
21	LAN (RTL8111GS)	1A	
22	WLAN/KB-BL	1A	
23	HDD/ODD/G-SENSOR/TP/FAN	1A	
24	Audio ALC233-CG	1A	
25	LED/PS/DMIC	1A	
26	POWER +VCC_CORE (ISL95835)	1A	
27	POWER 3VPCU&RVCC5 (PM6686)	1A	
28	POWER 1.5VSUS/VTT_MEM	1A	
29	POWER +1.05V (G5602R41U) -15A	1A	
30	POWER VCCSA/VCCIO	1A	
31	POWER VCC1.8/Thermal	1A	
32	POWER (BAT IN / ADA IN/ UL)	1A	
33	POWER CHARGER (ISL88731C)	1A	
34	POWER VGA_CORE ( RT8812A)	1A	
35	POWER VCC1.5_VRAM/1.05V	1A	
36	NVIDIA N14 GB2-64 PCIE 1/4	1A	
37	NVIDIA N14 GB2-64 TMDS 2/4	1A	
38	NVIDIA N14 GB2-64 VRAM 3/4	1A	
39	NVIDIA N14 GB2-64 VRAM 4/4	1A	

Page	Title of schematic page	Rev.	Date
42	HOLE/EMI/KB	1A	
43	AUDIO Woofer	1A	
44	IO PORT LIST	1A	
		1A	

\* : No mount  
L@ : For LVDS output  
D@ : For eDP output  
E@ : For DIS GFX  
I@ : For UMA

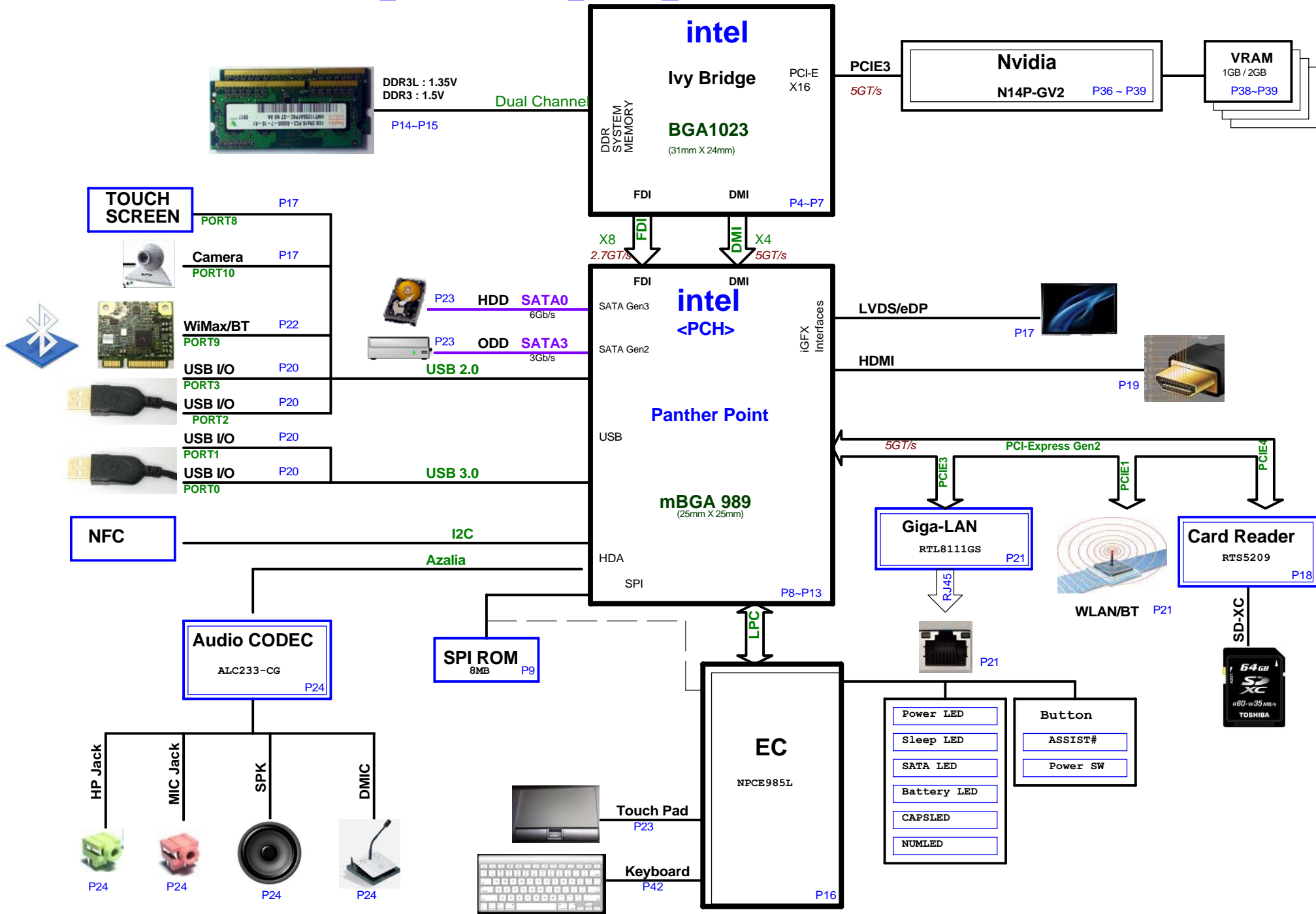

<http://laptopblue.vn/>

**Change List**

**MB\_SCH\_PVT\_001**  
P22-Add R333 0\_6S.  
P22- U15 don't mount  
P22-Add Q32(2N7002).  
P22-Add R335(100K\_4).  
Reason : Modify circuit for KB Backlight.  
Possible Risk: No.

**MB\_SCH\_PVT\_002**  
P23-CON11.11 delete net"DATA\_ODD\_DA#  
P10-U17.G40 delete net"SATA\_ODD\_DA#".  
P10-Delete R64(10K\_4).  
Reason : Modify circuit for Zero Power ODD.  
Possible Risk: No.

**MB\_SCH\_PVT\_002**  
P08-ADD 0.1UF on "PCH\_PWROK\_EC"  
Reason : Modify circuit for ESD.  
Possible Risk: No.

http://laptopblue.vn/

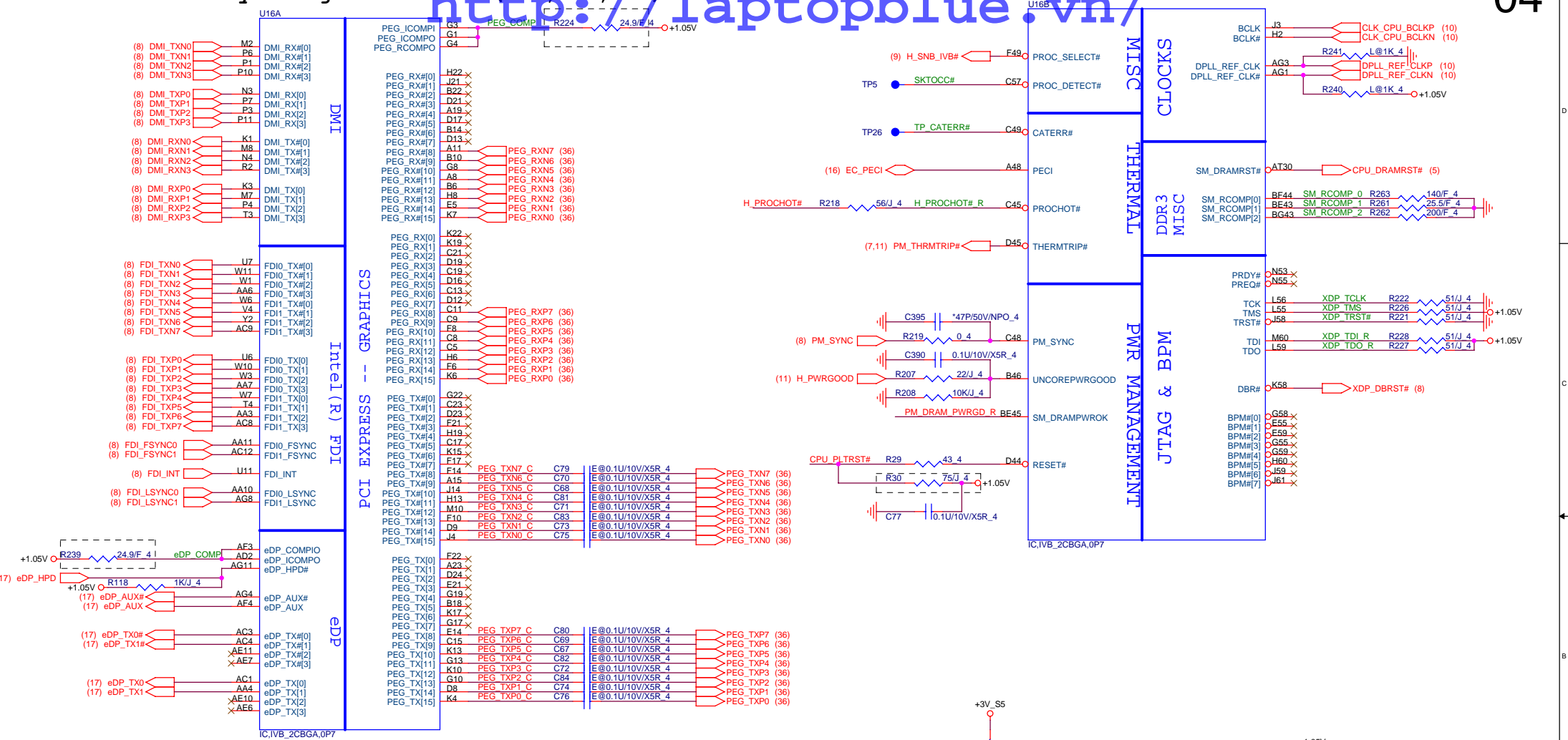

SNB\_IVB#:  
 - It is NC when using Sandy Bridge (1.05V)  
 - For next generation processor it will be grounded (1.0V)

**FDI Disabling (Discrete Only)**  
 - FDI\_FSYNC (J18/J17/J19/H17) can gang all these 4 signals together and tie them with only one 1K resistor to GND (DG V0.5 Ch2.2.9).  
 - FDI\_INT connect to GND with 1K ohm.

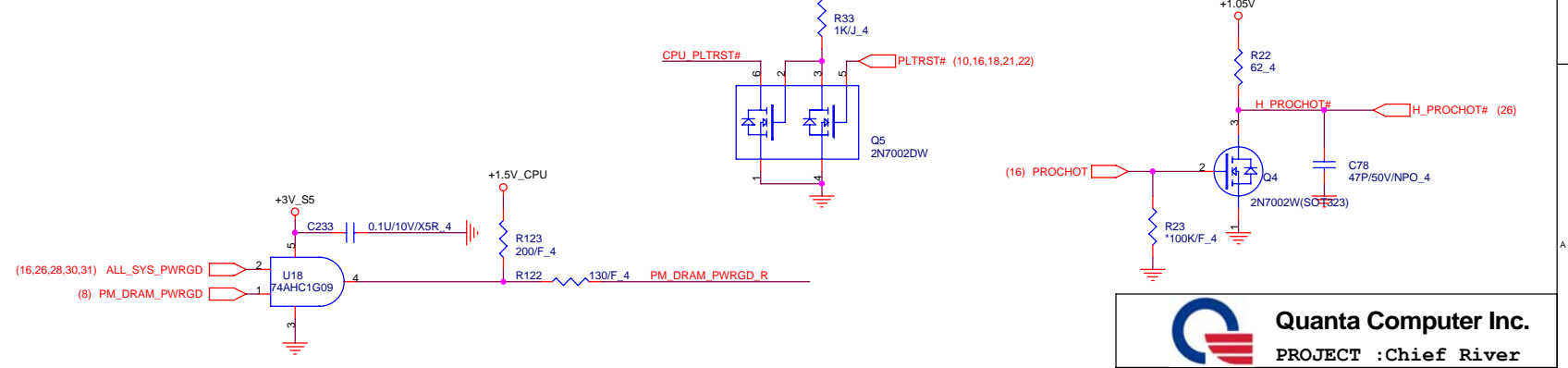

**Quanta Computer Inc.**  
 PROJECT :Chief River

Size	Document Number	Rev
	<b>SNB/IVB 1/4</b>	1A

Date: Thursday, January 17, 2013 Sheet 4 of 41

1. Level 1 Environment-related Substances Should Never be Used.  
 2. Recycled Resin and Coated Wire should be procured from Green Partners.

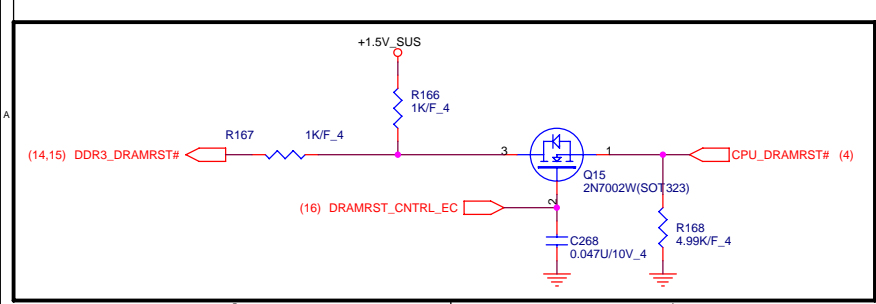
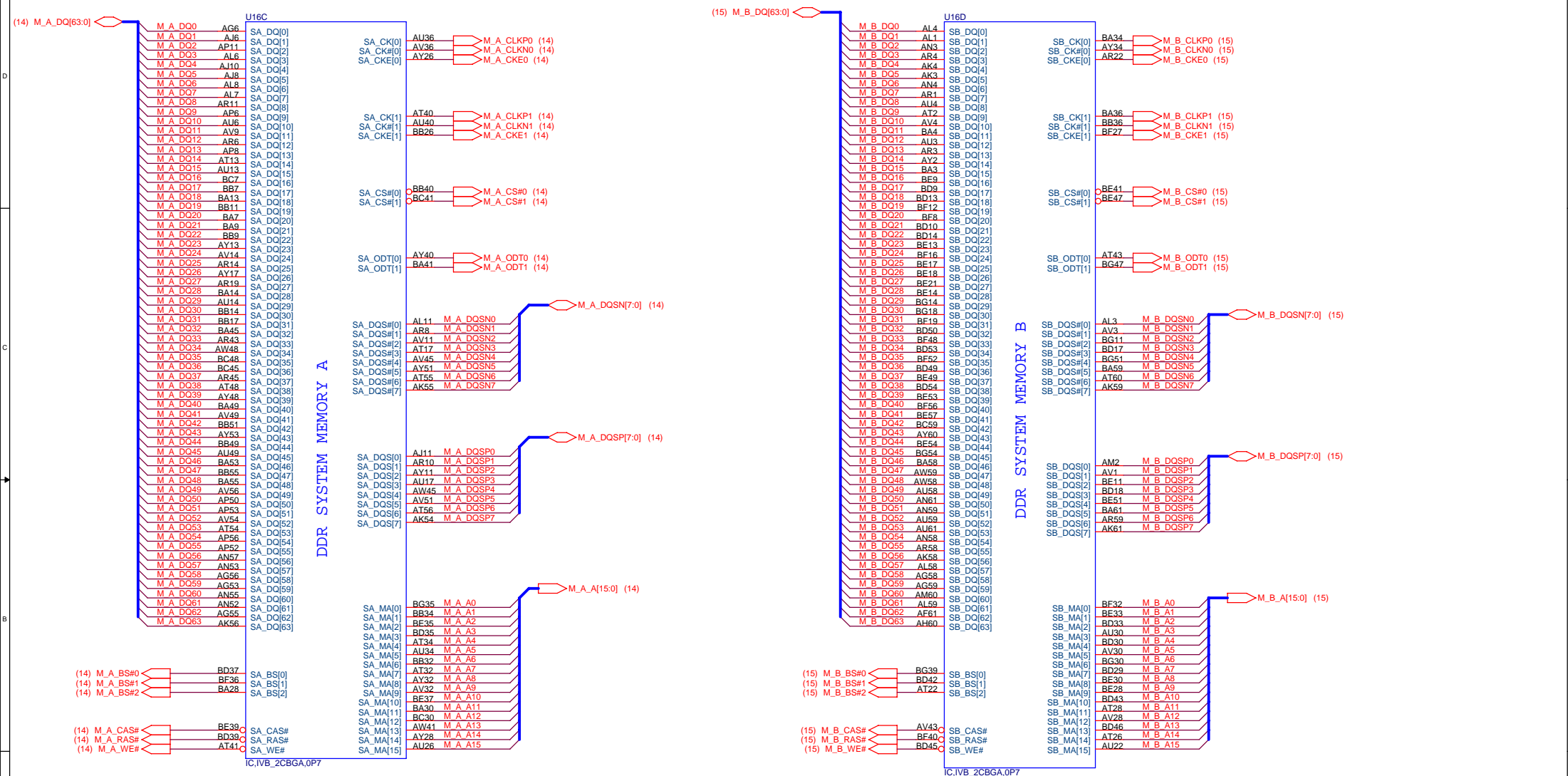

**Quanta Computer Inc.**  
PROJECT :Chief River

Size	Document Number	Rev	
	<b>SNB/IVB 2/4</b>	1A	
Date:	Thursday, January 17, 2013	Sheet	5 of 41

1.Level 1 Environment-related Substances Should Never be Used.  
2.Recycled Resin and Coated Wire should be procured from Green Partners.





Ivy Bridge Processor (GND)

Ivy Bridge Processor (RESERVED, CFG)

http://laptopblue.vn/

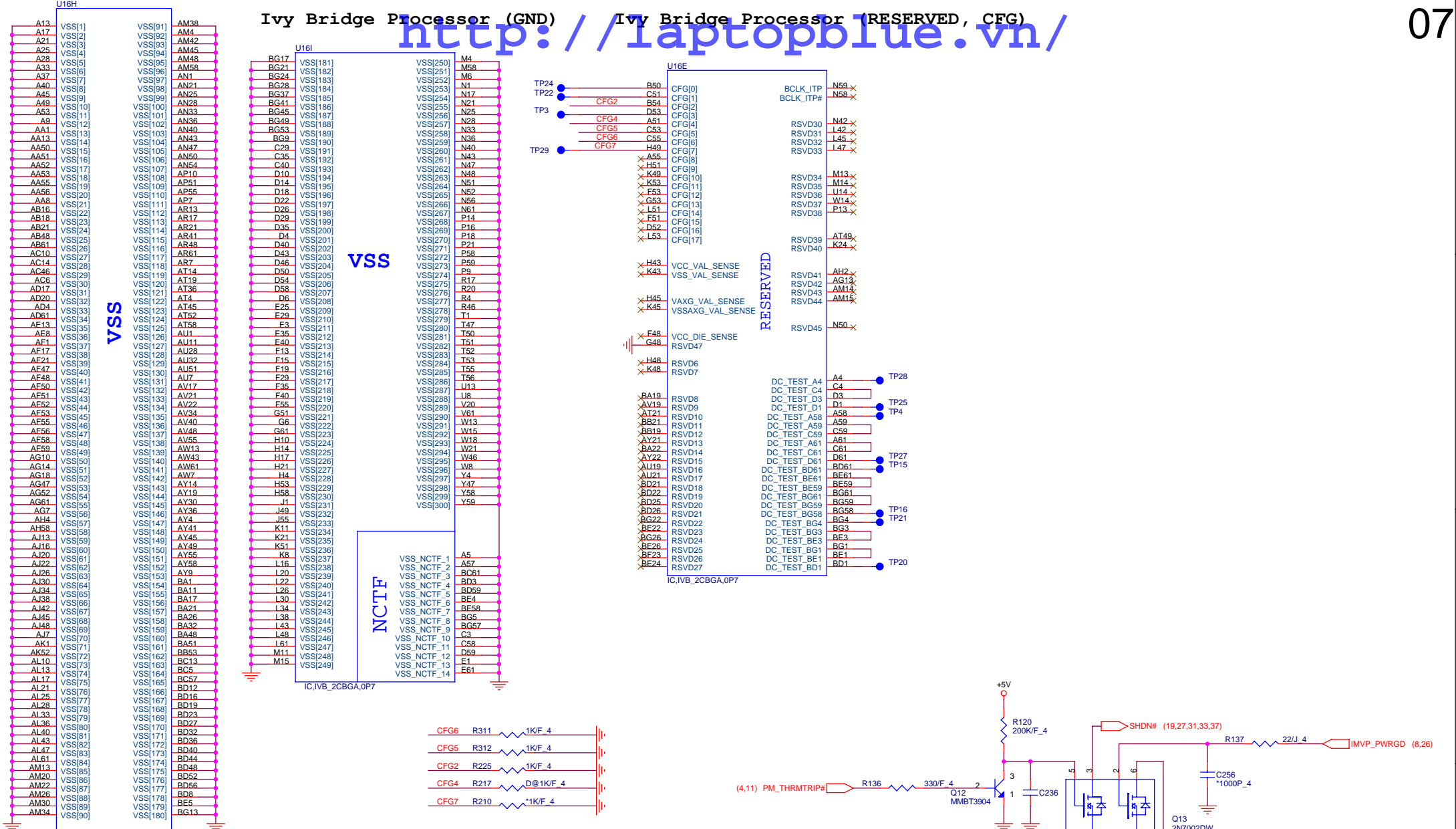

The CFG signals have a default value of '1' if not terminated on the board.

Processor Strapping

	1	0
CFG2 (PEG Static Lane Reversal)	Normal Operation	Lane Reversed
CFG4 (DP Presence Strap)	Disable; No physical DP attached to eDP	Enable; An ext DP device is connected to eDP
CFG7 (PEG Defer Training)	PEG train immediately following xxRESETB de assertion	PEG wait for BIOS training

CFG[6:5] (PCIe Port Bifurcation Straps)

11: (Default) x16 - X16 PEG interface  
 10: PEG x8 x8 bifurcation enabled/disabled  
 01: Reserved - (Device 1 function 1 disabled ; function 2 enabled)  
 00: x8,x4,x4 - Device 1 functions 1 and 2 enabled

**Quanta Computer Inc.**  
 PROJECT :Chief River

Size Document Number  
**SNB/IVB 4/4** Rev 1A

Date: Thursday, January 17, 2013 Sheet 7 of 41

1.Level 1 Environment-related Substances Should Never be Used.  
 2.Recycled Resin and Coated Wire should be procured from Green Partners.









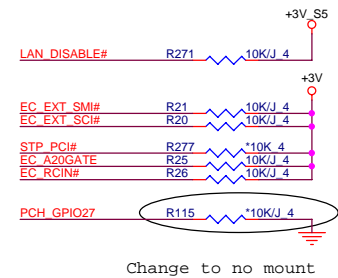
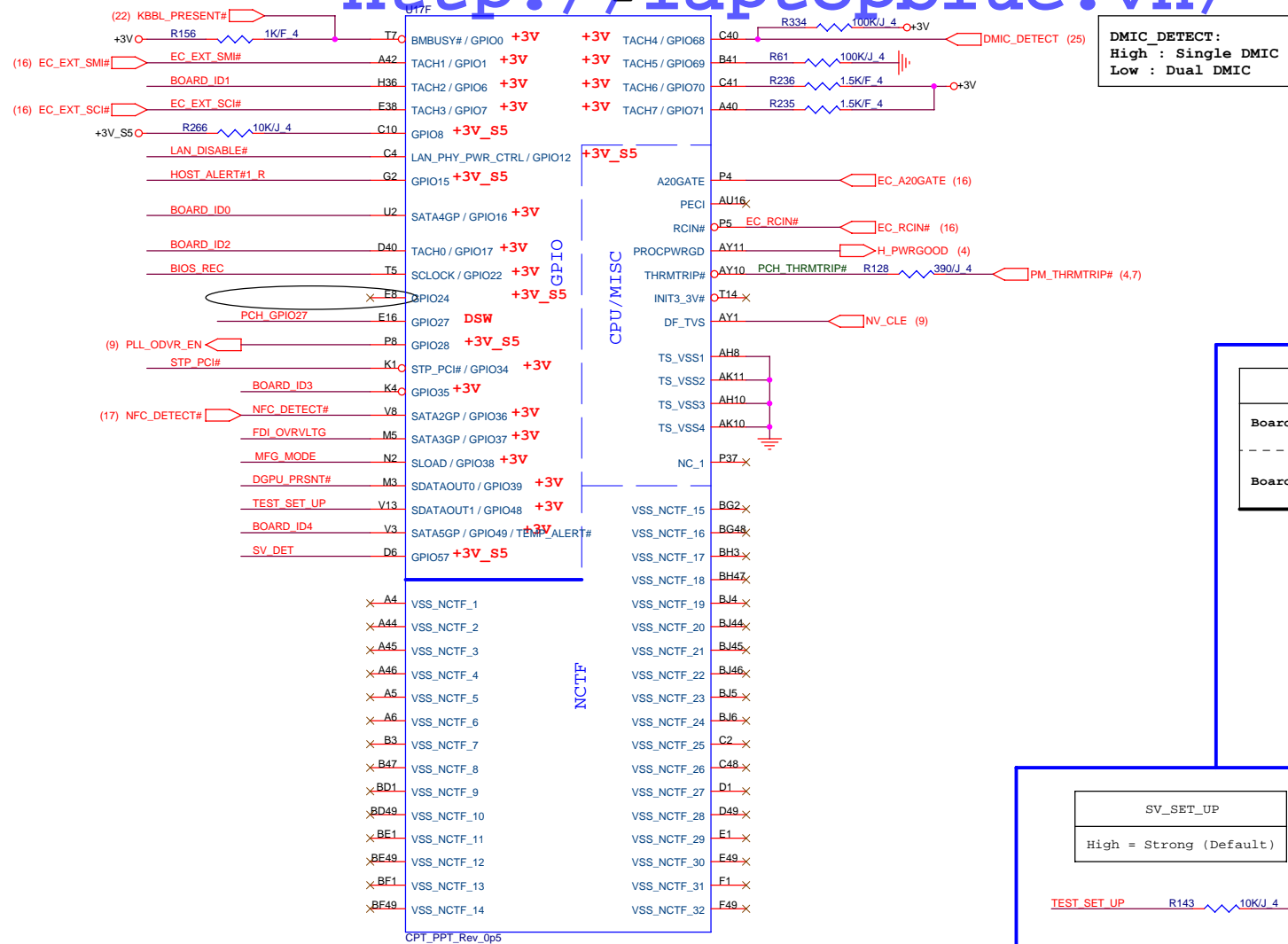

	0	1
Board ID0	CaspiCRA1-CaspiCRB1 HK8-HK9	SuperiorCRA1-SuperiorCRB1 GD5-GD6
Board ID1	HK8/GD5 14"	HK9/GD6 15"

SV\_SET\_UP

High = Strong (Default)

TEST SET UP R143 10K/J 4

HOST\_ALERT#1\_R R270 1K/J 4

Intel ME Crypto Transport Layer Security (TLS) cipher suite

Low = Disable (Default)

High = Enable

MFG-TEST

MFG\_MODE R281 10K/J 4

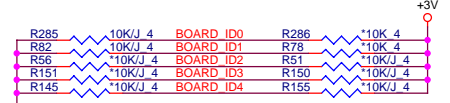

PCBA SKU	Discrete	UMA
R280 (Pull High)	Stuff	No Stuff
R279 (Pull Low)	No Stuff	Stuff

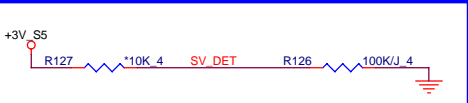

FDI TERMINATION VOLTAGE OVERRIDE

LOW - Tx, Rx terminated to same voltage

NFC\_DETECT# R144 100K/J 4

NFC Detect

High : No NFC Module Plug

Low : NFC Module Plug

BIOS\_REC R157 10K/J 4

BIOS RECOVERY

High = Disable (Default)

Low = Enable

Quanta Computer Inc.

PROJECT :Chief River

CPT/PPT 4/6



CPT/PPT (GND)

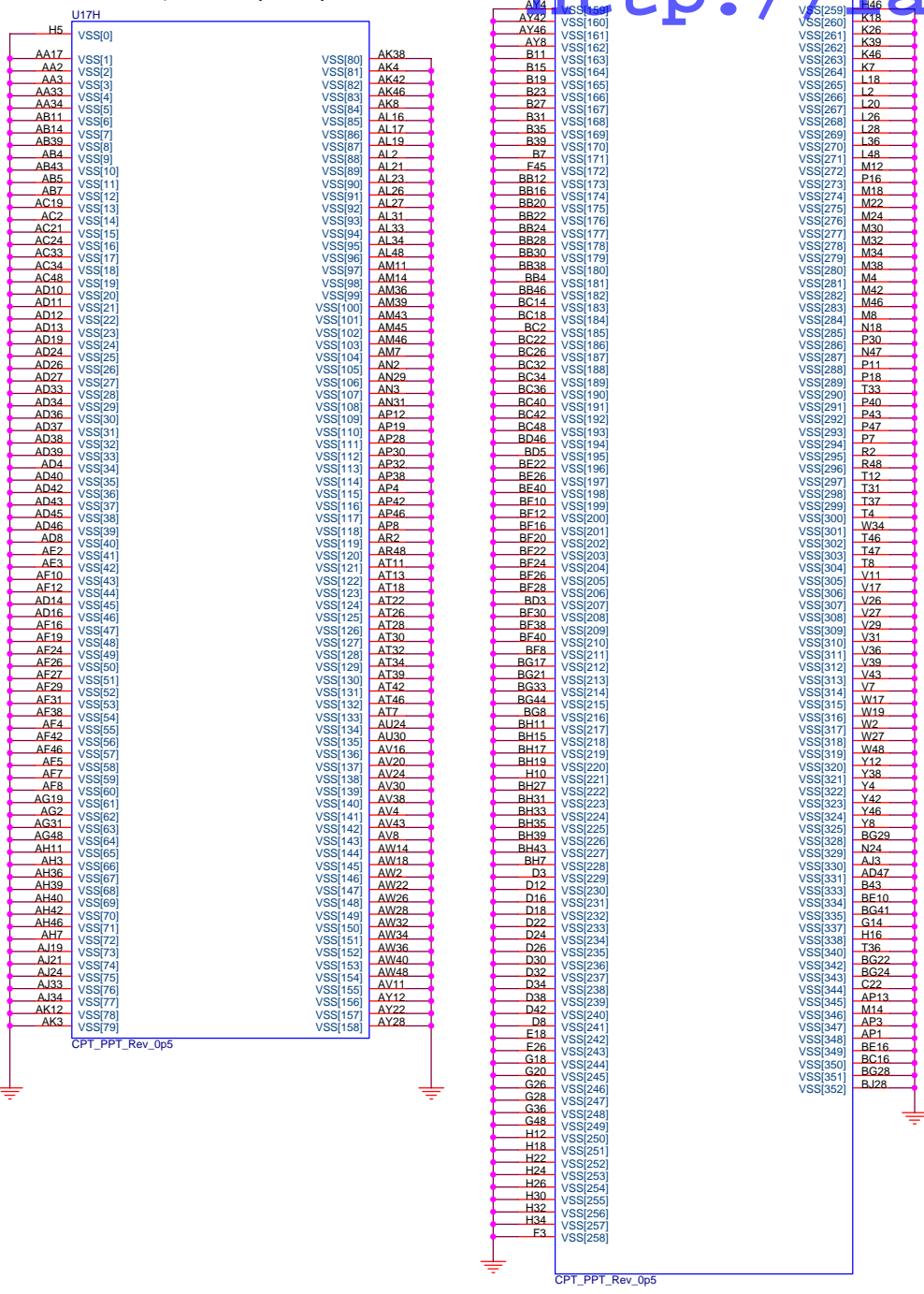

**Quanta Computer Inc.**  
PROJECT :Chief River

Size	Document Number	Rev
	CPT/PPT 6/6	1A

1.Level 1 Environment-related Substances Should Never be Used.  
2.Recycled Resin and Coated Wire should be procured from Green Partners.

Date: Thursday, January 17, 2013 Sheet 13 of 41

http://laptopblue.vn/

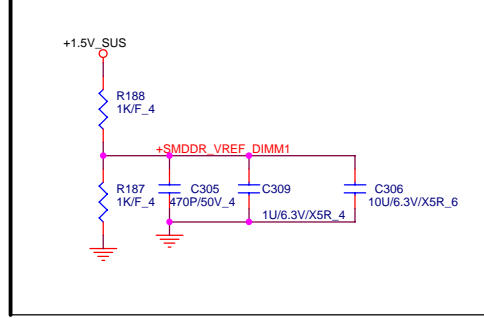
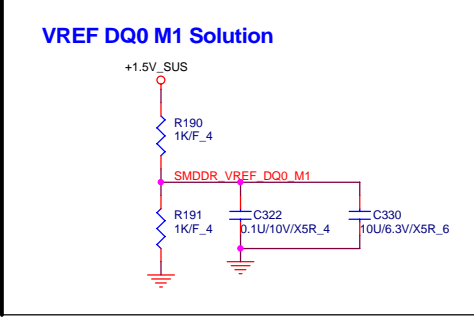
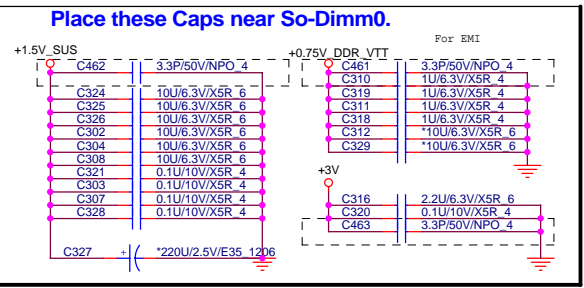
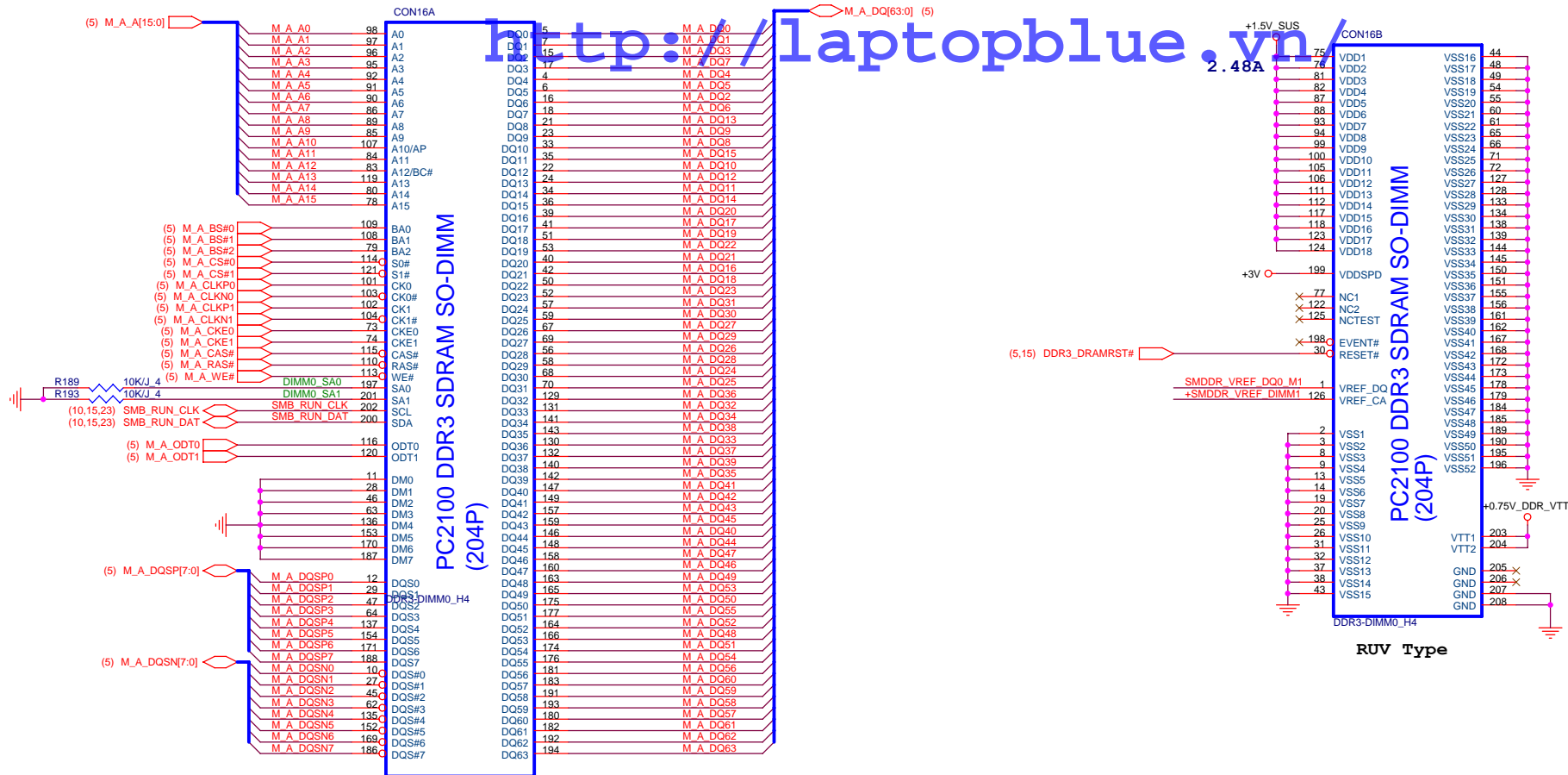

**Quanta Computer Inc.**  
PROJECT :Chief River

Size: Document Number: **DDRIII SO-DIMM-0** Rev: 1A

Date: Thursday, January 17, 2013 Sheet: 14 of 41

1.Level 1 Environment-related Substances Should Never be Used.  
2.Recycled Resin and Coated Wire should be procured from Green Partners.



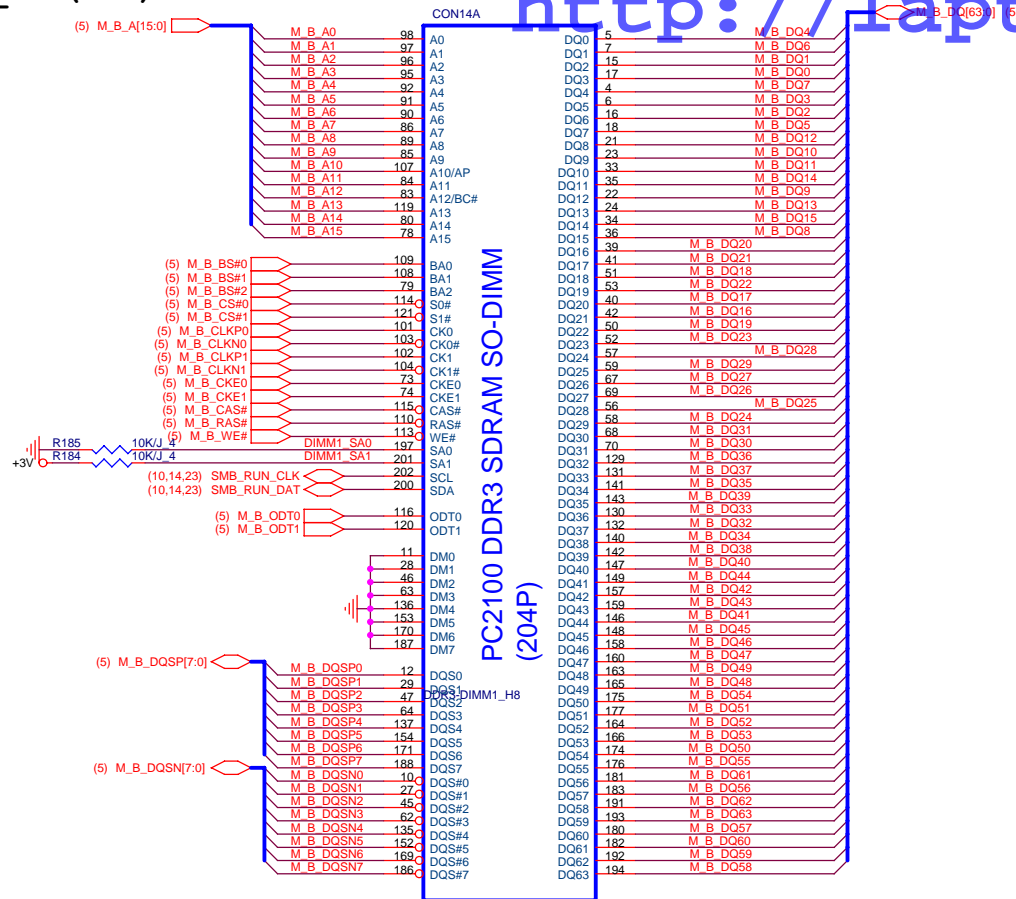

RUV Type

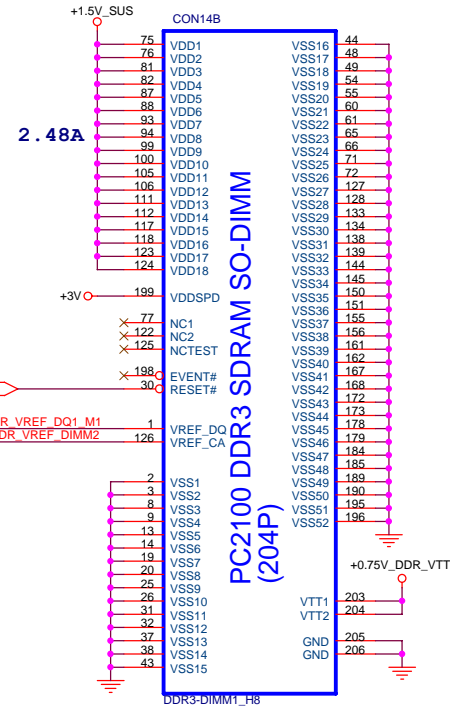

RUV Type

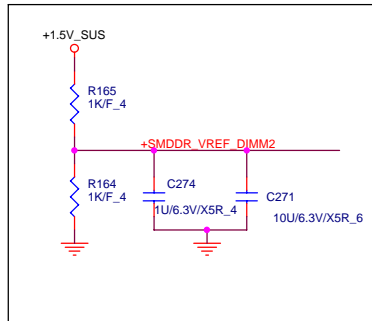
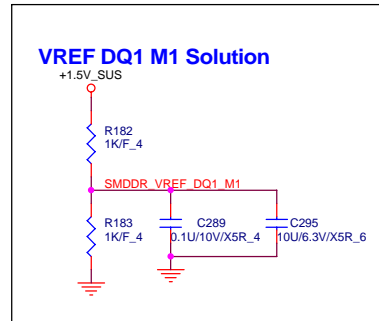
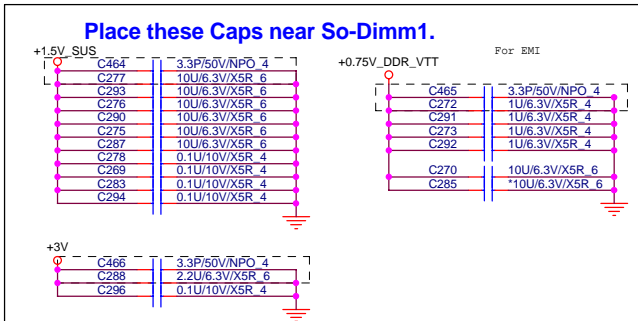

**Quanta Computer Inc.**  
PROJECT :Chief River

Size Document Number **DDRIII SO-DIMM-1** Rev 1A

Date: Thursday, January 17, 2013 Sheet 15 of 41

1.Level 1 Environment-related Substances Should Never be Used.  
2.Recycled Resin and Coated Wire should be procured from Green Partners.

\*\* Strapping Pin, Can not pull low. Note the input leakage current to the strap pins must be less than 10uA.

Since ECSCI is OD, no need for a back-drive protection diode on this signal. But note there is internal PU in chipset at default

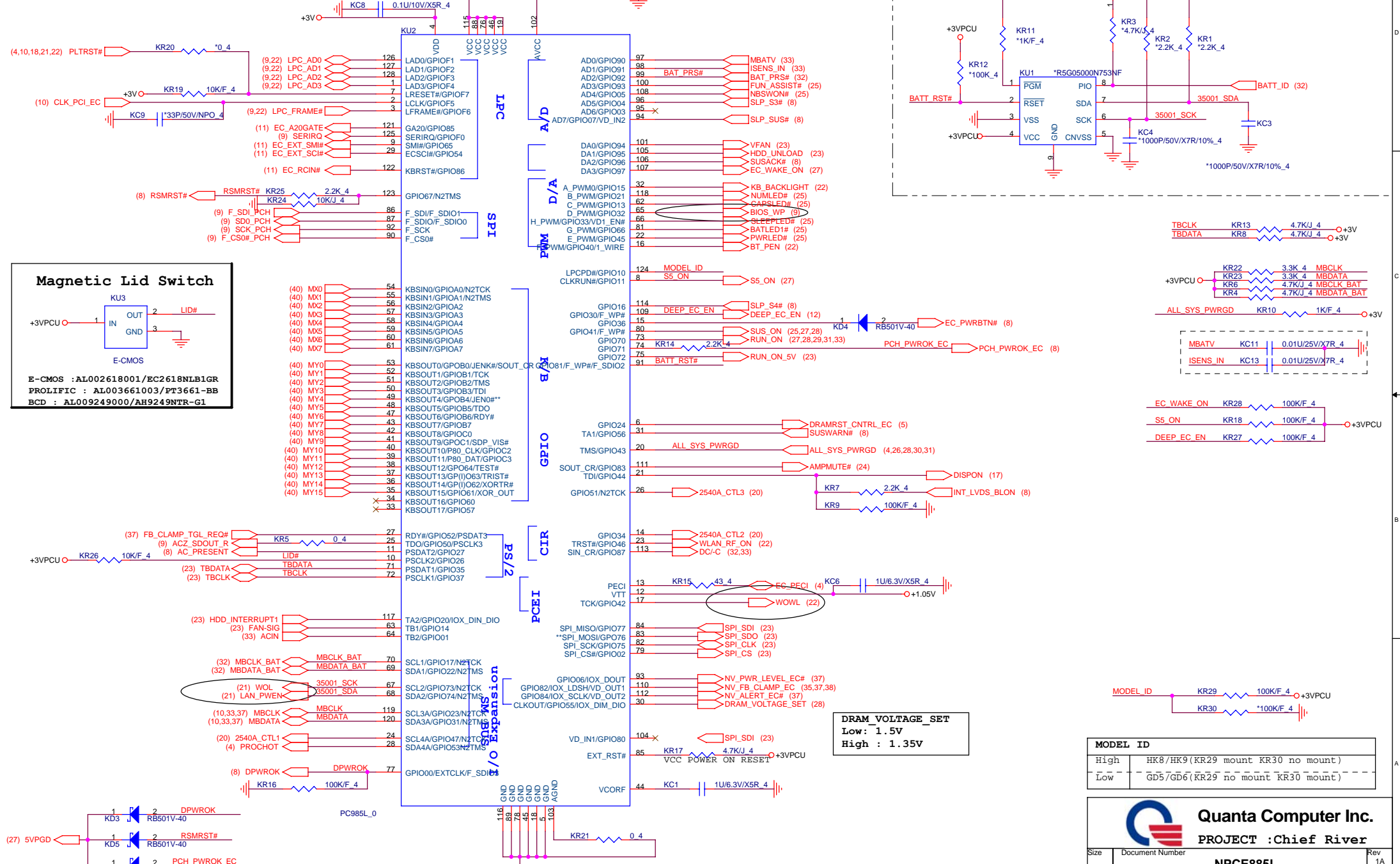

**Magnetic Lid Switch**

E-CMOS

E-CMOS : AL002618001/EC2168NLB1GR  
 PROLIFIC : AL003661003/PT3661-BB  
 BCD : AL009249000/AH9249NTR-G1

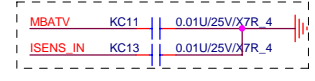
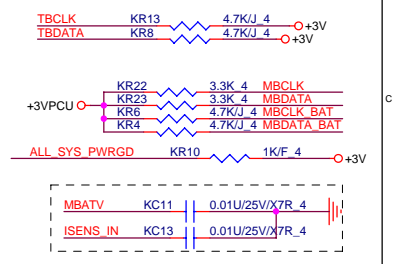
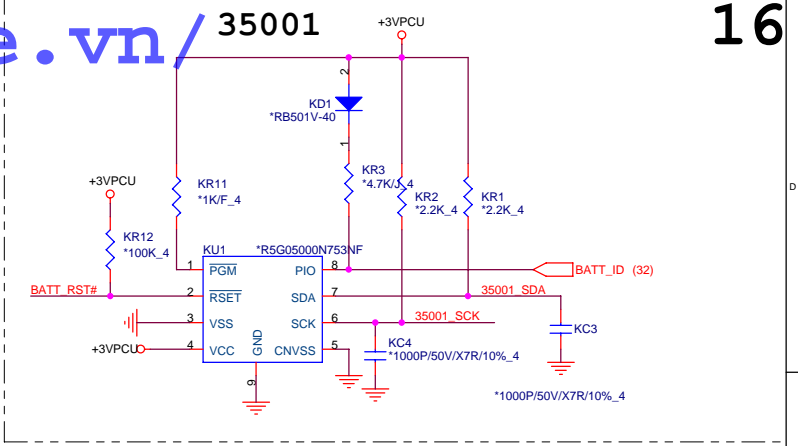

**DRAM VOLTAGE SET**  
 Low : 1.5V  
 High : 1.35V

MODEL ID	
High	HK8/HK9 (KR29 mount KR30 no mount)
Low	GD5/GD6 (KR29 no mount KR30 mount)

**Quanta Computer Inc.**  
**PROJECT : Chief River**

Size: Document Number: NPCE885L Rev 1A

Date: Thursday, January 17, 2013 Sheet 16 of 41

1. Level 1 Environment-related Substances Should Never be Used.  
 2. Recycled Resin and Coated Wire should be procured from Green Partners.

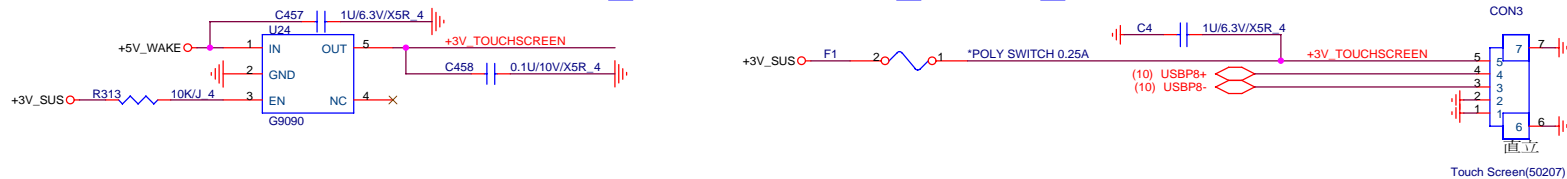

NFC module :  
 Vender : Samsung SNC-i20  
 Power consumption : Max. 160mW/48mA  
 Power Ripple +/- 50mV

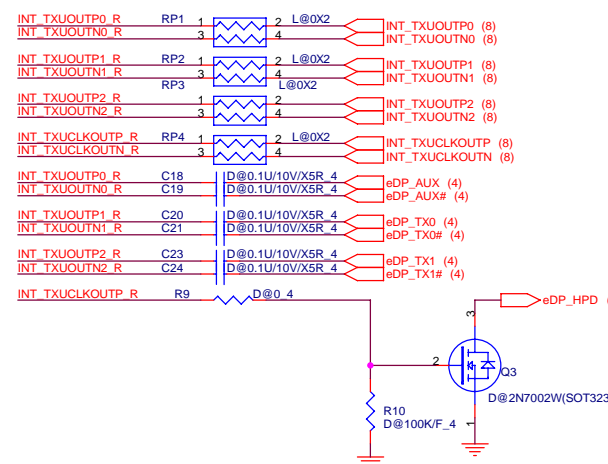
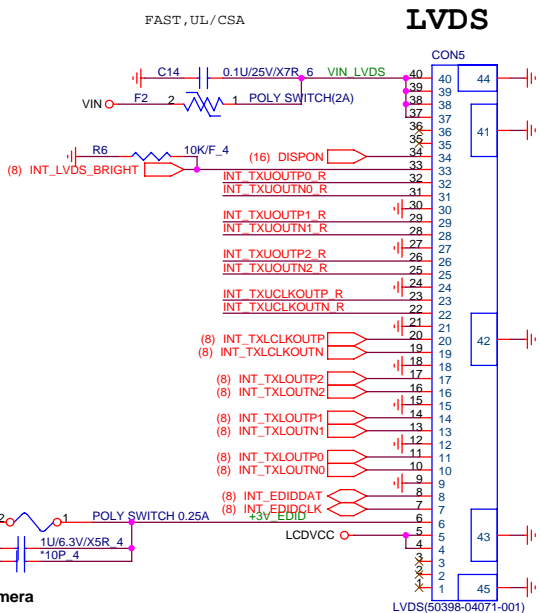

Camera HD specification  
 Voltage: Max. 3.6V  
 Current : Max. 200mA  
 OCP: 200mA ~ 300mA

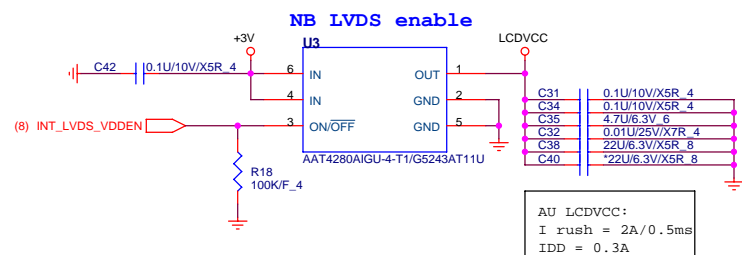

AU LCDVCC:  
 I rush = 2A/0.5ms  
 IDD = 0.3A

## NFC

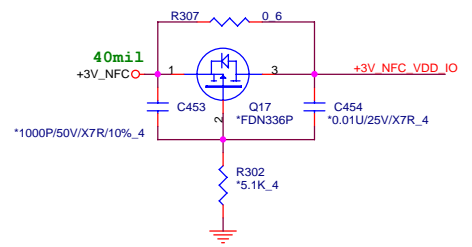
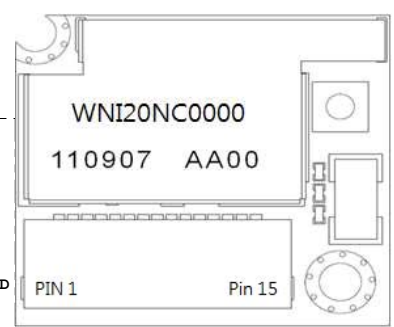
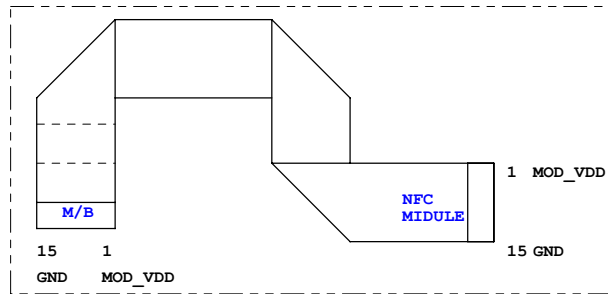
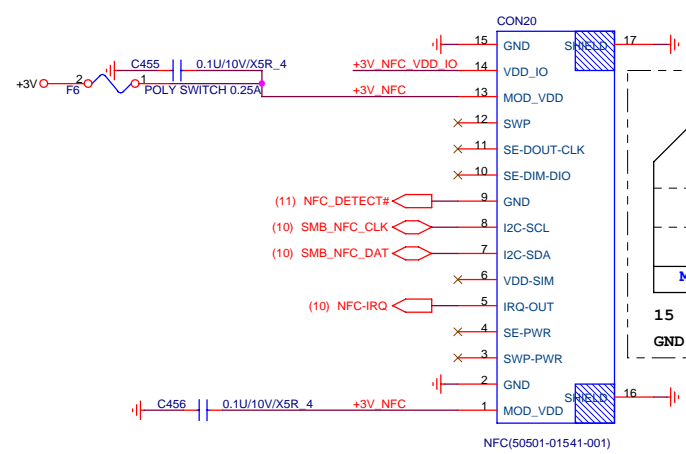

**Quanta Computer Inc.**  
 PROJECT :Chief River

Size	Document Number	Rev
	CRT/LVDS	1A

Date: Thursday, January 17, 2013 Sheet 17 of 41

1. Level 1 Environment-related Substances Should Never be Used.  
 2. Recycled Resin and Coated Wire should be procured from Green Partners.

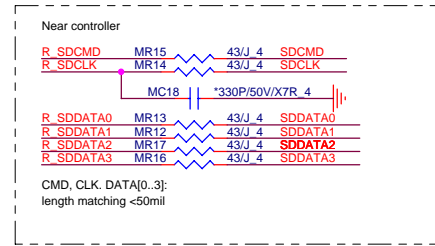
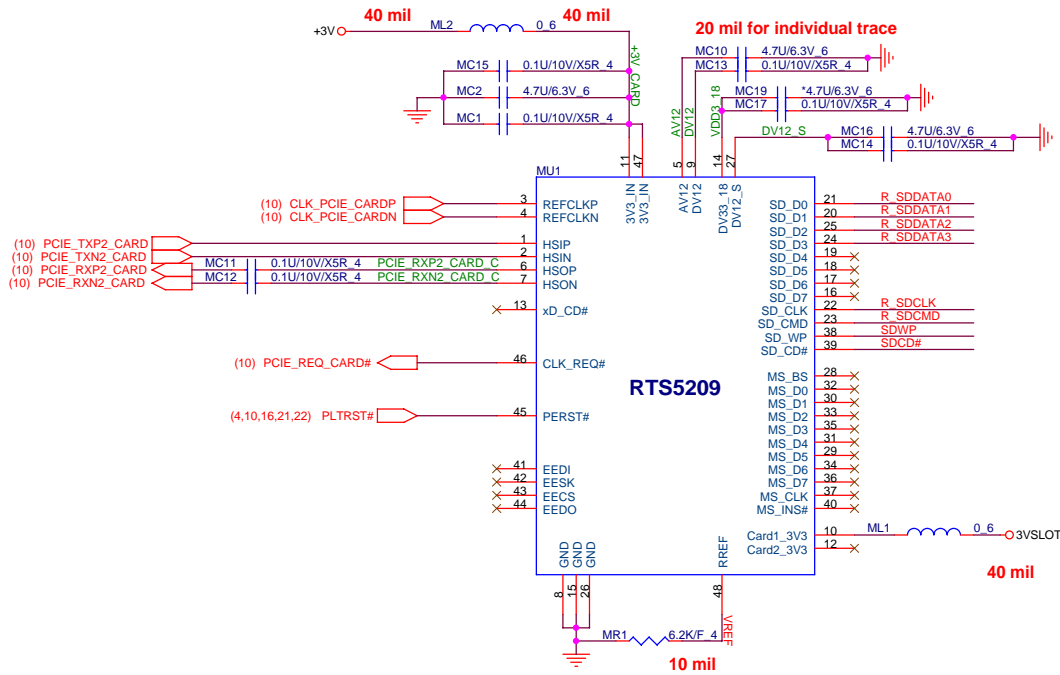

These component need to close to Slot

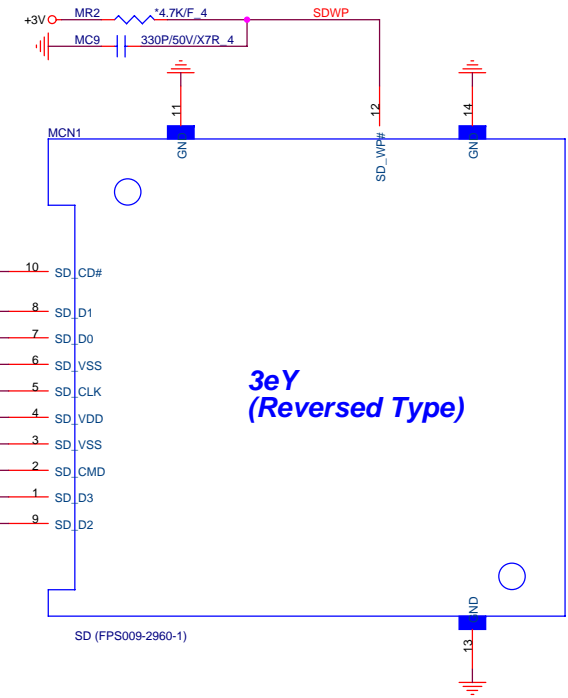
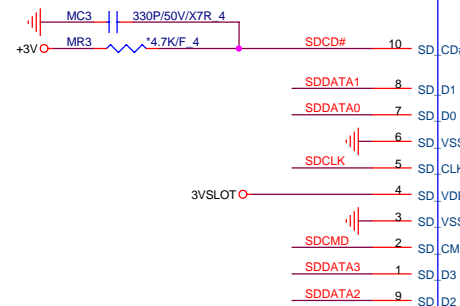
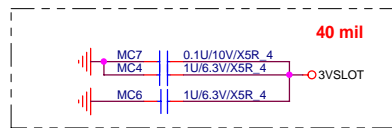

**Quanta Computer Inc.**  
**PROJECT :Chief River**  
**CARD**

Size	Document Number	Rev
		1A

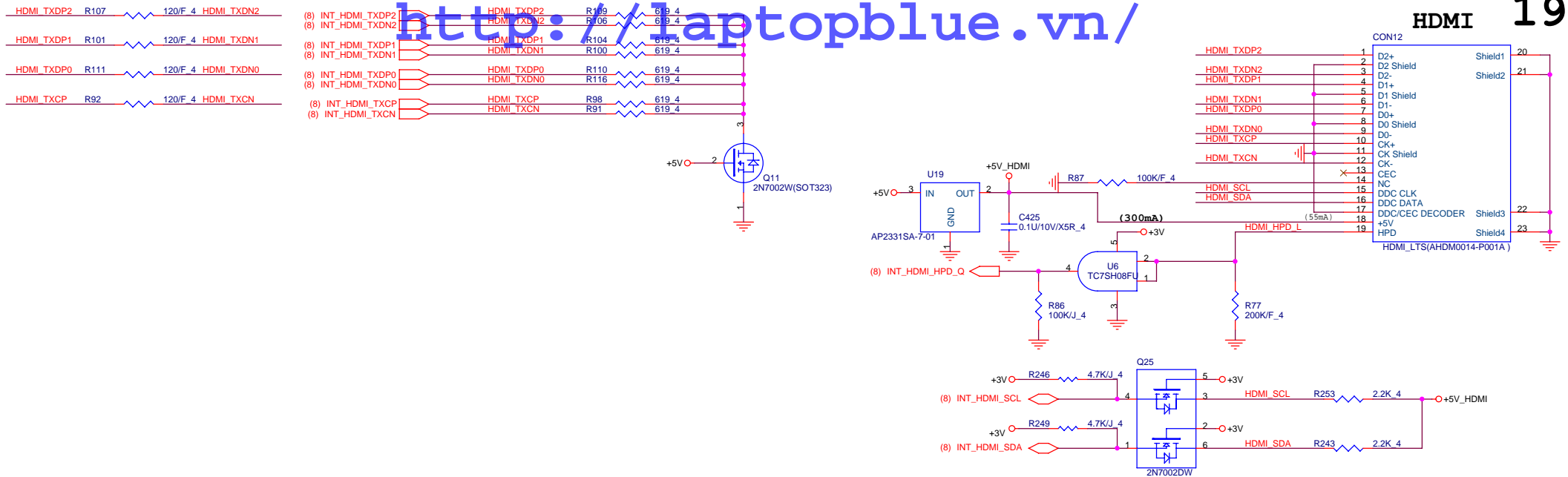

H/W Thermal Protect

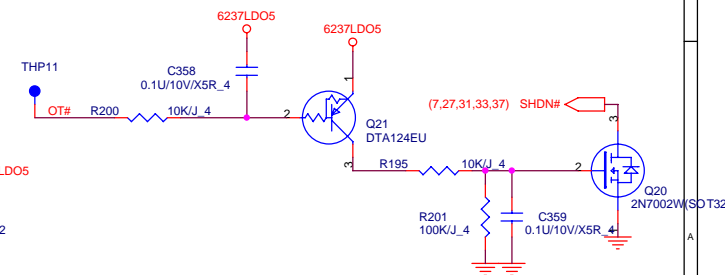
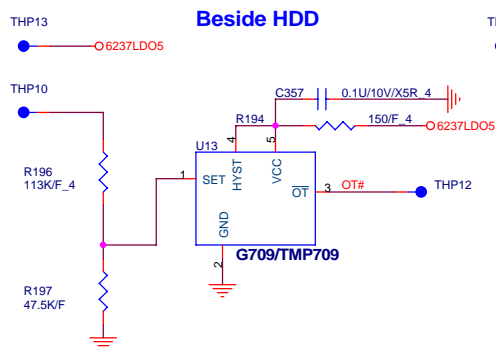
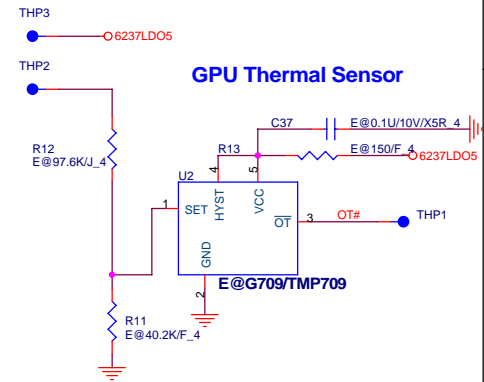
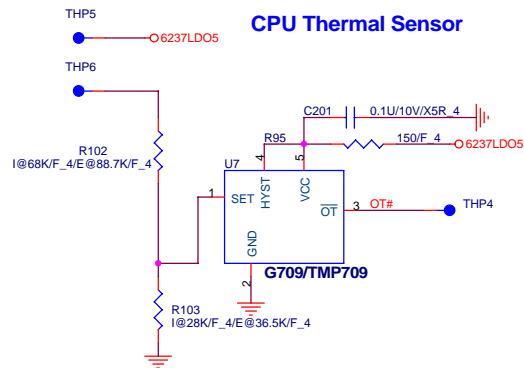
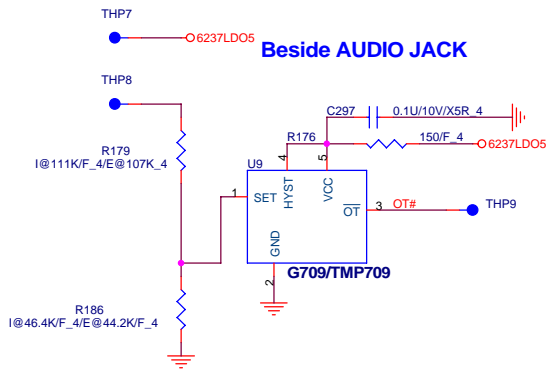

RSET(kΩ) = 0.0012T<sup>2</sup> - 0.9308T + 96.147

95	18.5K
100	15K
107	10.3K
110	8.2K

DIS SKU

Location of IC	Temp	R-Set	Parts in BOM	Max	Min
Near CPU sensor temp	70	R208=36.87K	36.5K	71	70
Near GFX sensor temp	65	R146=40.72K	40.2K	66.3	65.1
Near AUDIO sensor temp	60	R345=44.62K	44.2K	61.2	60

UMA SKU

Location of IC	Temp	R-Set	Parts in BOM	Max	Min
Near CPU sensor temp	81	R208=28.63K	28K	82.3	81.4
Near AUDIO sensor temp	58	R345=46.2K	46.4K	58.4	57.1

**Quanta Computer Inc.**  
PROJECT :Chief River

Size	Document Number	Rev
	<b>HDMI/Thermal IC</b>	1A

1.Level 1 Environment-related Substances Should Never be Used.  
2.Recycled Resin and Coated Wire should be procured from Green Partners.

# MB to USB board

<http://laptopblue.vn/>

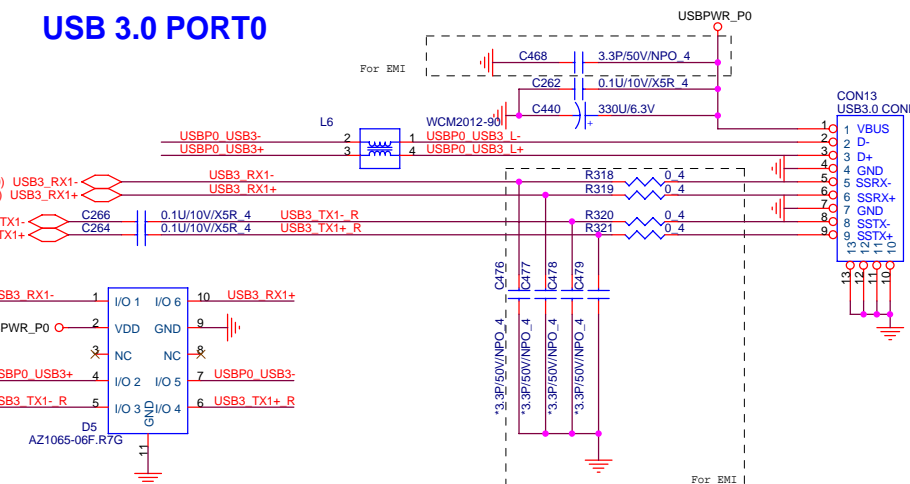
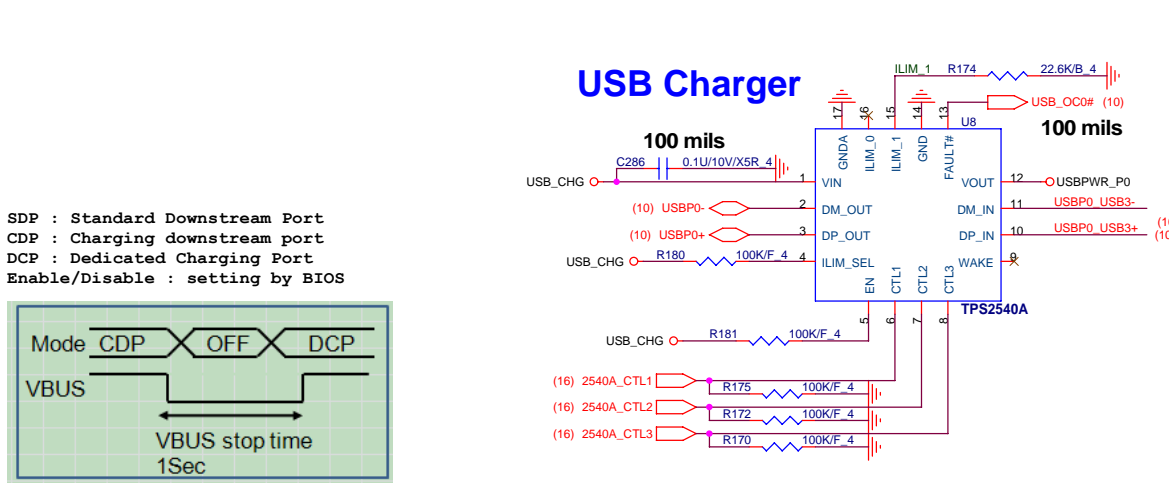
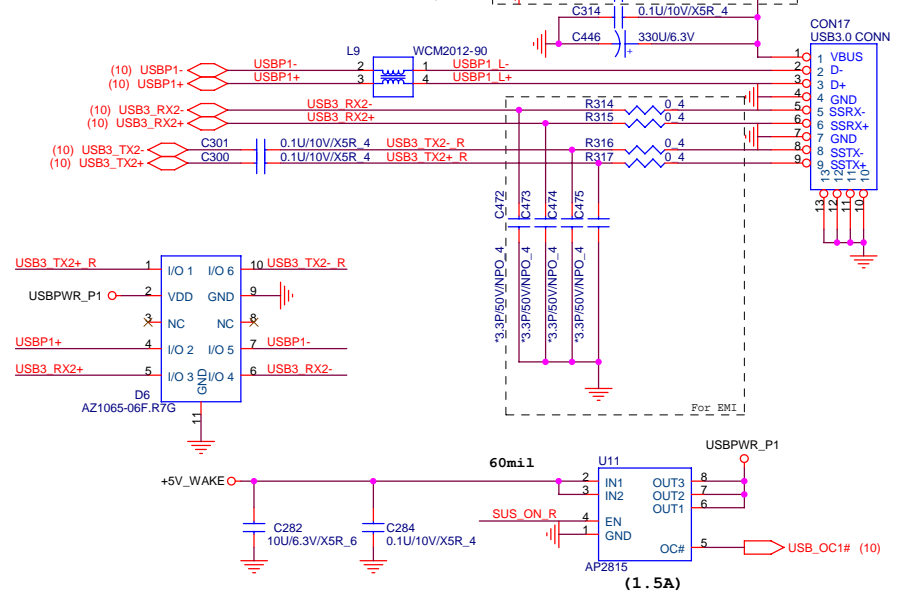
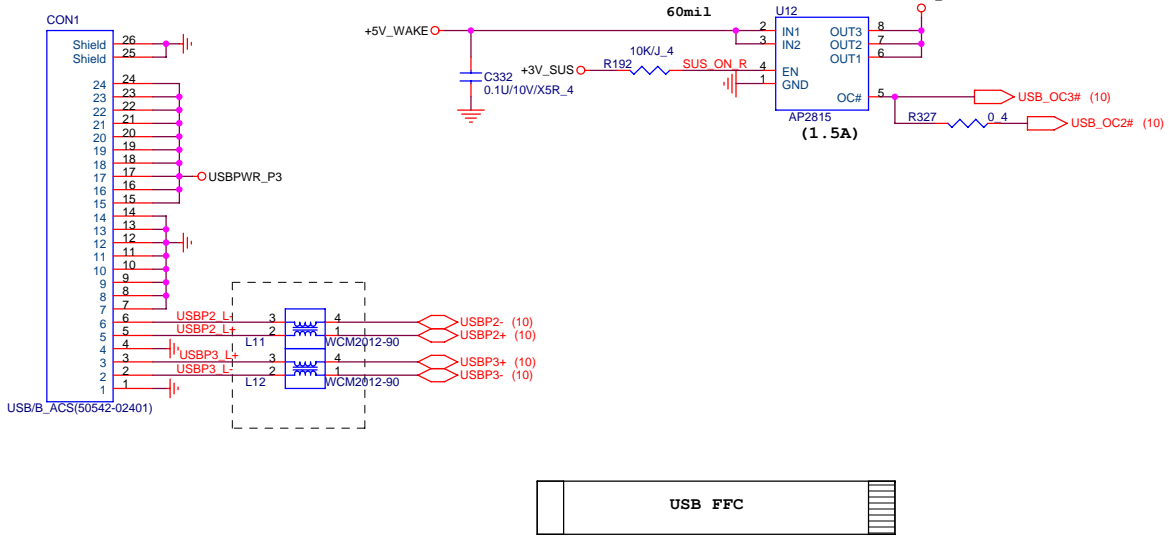

CTL_1	CTL_2	CTL_3	TPS 2540A/2543 Truth Table
0	0	0	OUT discharge, power switch OFF
0	X	1	DCP, Auto-detect(S3/S4/S5, 1.5A)
X	1	0	SDP, USB2.0 mode(S0, 0.5A)
1	0	0	DCP, BC SPEC1.2 only(S3/Deep standby/S4/S5, 1.5A)
1	0	1	DCP, Divider mode only(S3/S4/S5, 1.5A)
1	1	1	CDP (S0, 1.5A)

System State	USB Battery Charging Setting	
	Disable	Enable
S0	SDP (X 1 0)	CDP (1 1 1)
S3	SDP (X 1 0)	DCP BC (1 0 0)
DS3	Charger OFF (0 0 0)	DCP BC (1 0 0)
S4	Charger OFF (0 0 0)	DCP BC (1 0 0)
S5	Charger OFF (0 0 0)	DCP BC (1 0 0)

ILIM_SEL (I_LIMIT(A)= 48000R)	
HI	I_LIM_1
LO	I_LIM_0

48000/22.6K=2.123A

**Quanta Computer Inc.**  
 PROJECT : Chief River  
**USB/USB Charger**

Size: \_\_\_\_\_ Document Number: \_\_\_\_\_ Rev: 1A  
 Date: Thursday, January 17, 2013 Sheet 20 of 41

1. LEVEL 1 Environment-Related Substances should Never be Used.  
 2. Recycled Resin and Coated Wire should be procured from Green Partners.



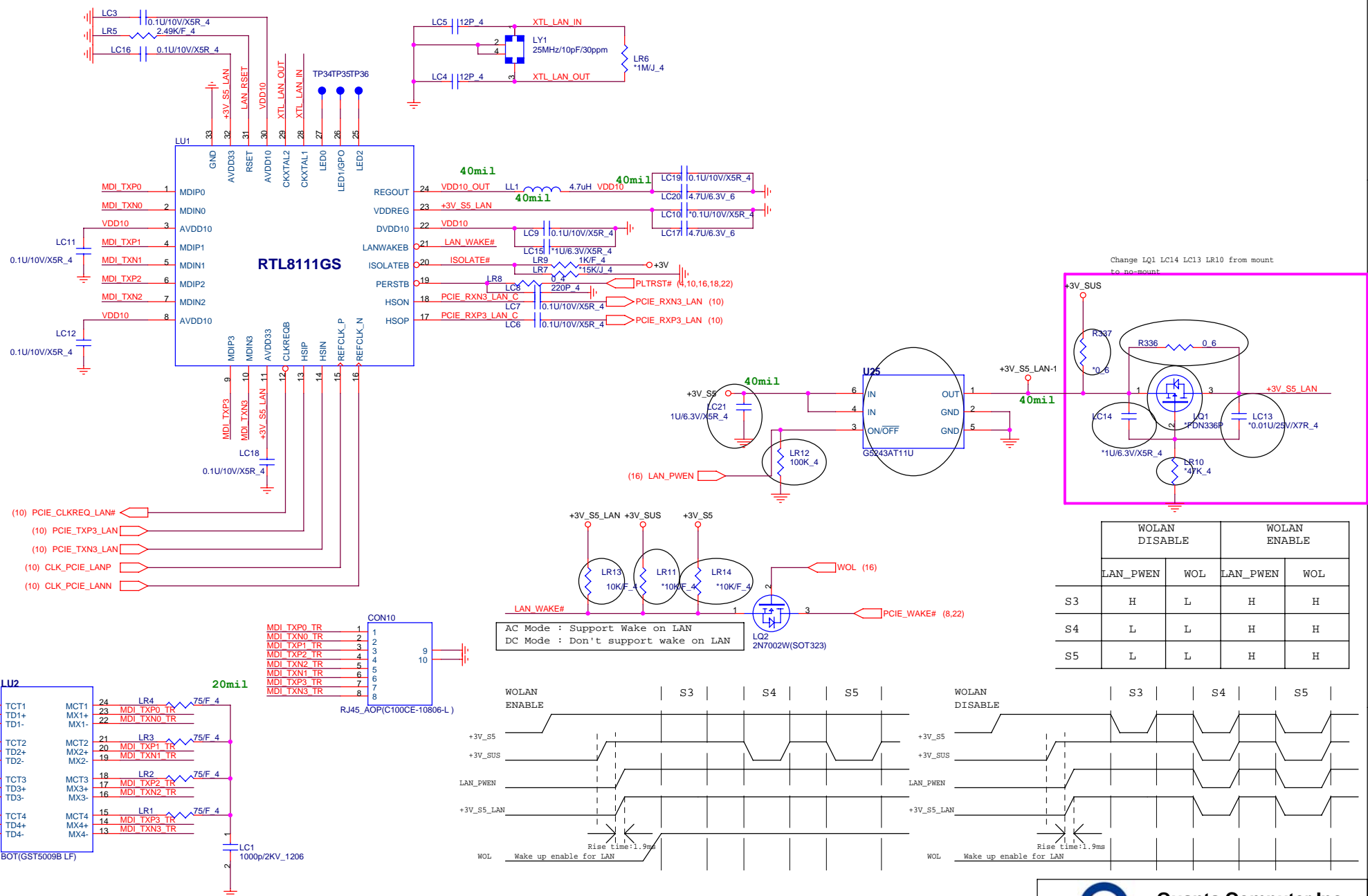

	WOLAN DISABLE		WOLAN ENABLE	
	LAN_PWEN	WOL	LAN_PWEN	WOL
S3	H	L	H	H
S4	L	L	H	H
S5	L	L	H	H

AC Mode : Support Wake on LAN  
DC Mode : Don't support wake on LAN

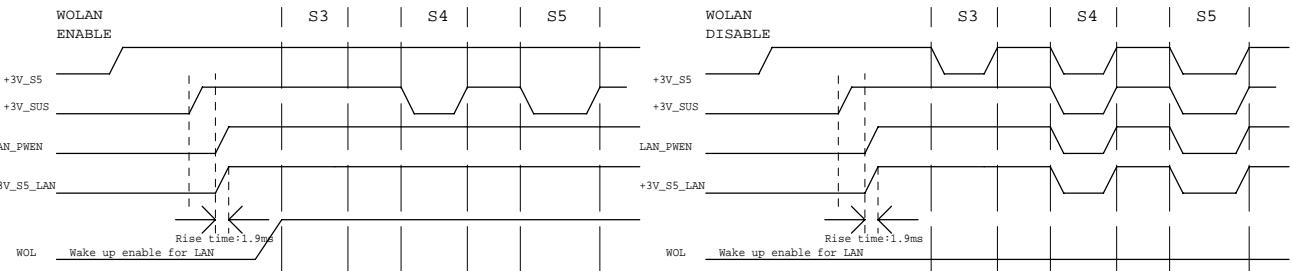

**Quanta Computer Inc.**  
PROJECT : Chief River  
**Giga LAN RTL8111GS**

Size	Document Number	Date	Thursday, January 17, 2013	Sheet	21	of	41	
							Rev	1A

1.Level 1 Environment-related Substances Should Never be Used.  
2.Recycled Resin and Coated Wire should be procured from Green Partners.

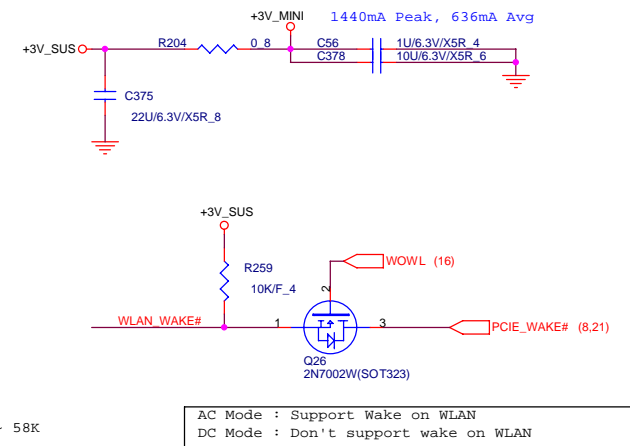
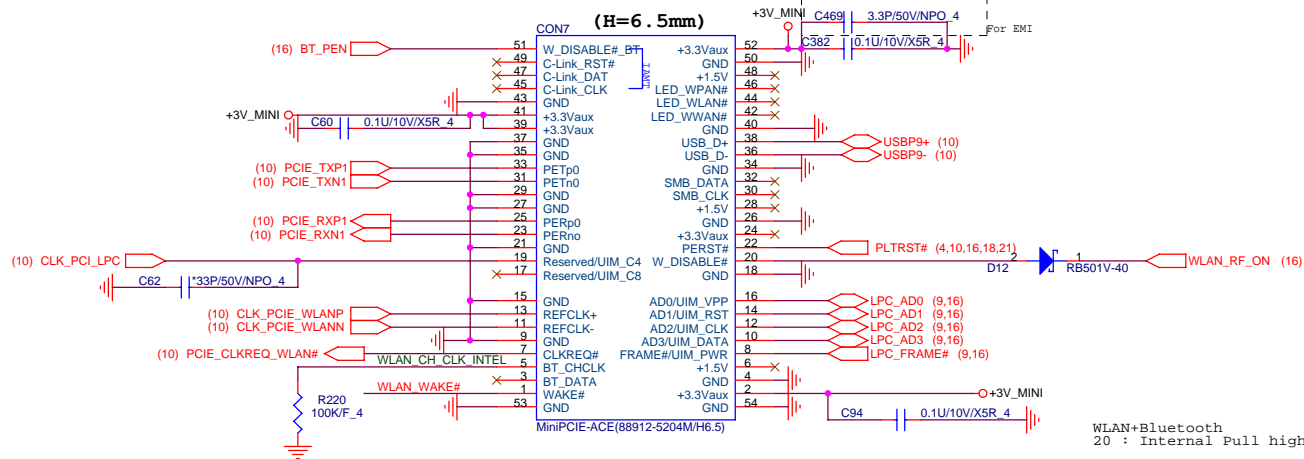

**KB BACKLIGHT**

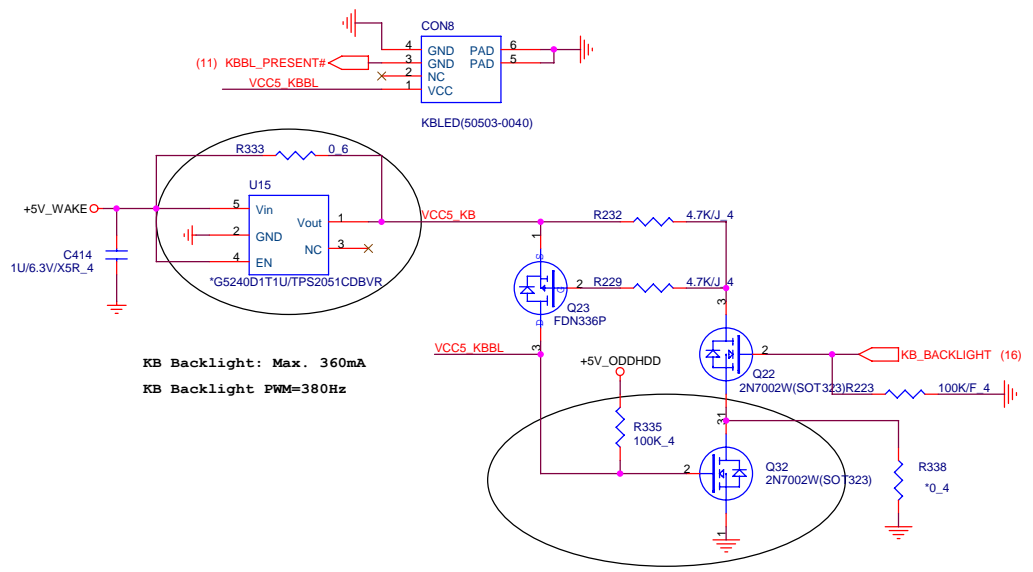

		<b>Quanta Computer Inc.</b> PROJECT :Chief River	
		Size Document Number <b>WLAN/KB BL</b>	Rev 1A
1.Level 1 Environment-related Substances Should Never be Used. 2.Recycled Resin and Coated Wire should be procured from Green Partners.		Date: Thursday, January 17, 2013	Sheet 22 of 41

# ODD CONNECTOR

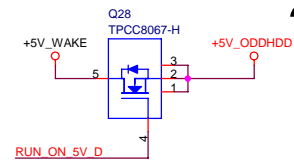
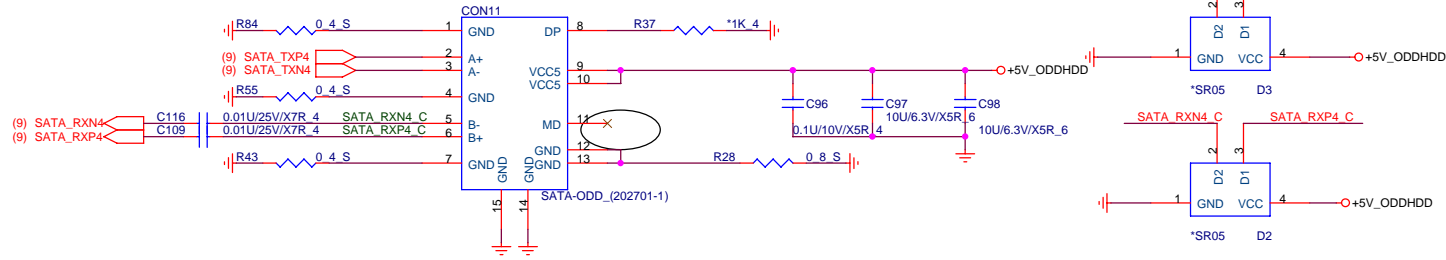

# HDD CONNECTOR

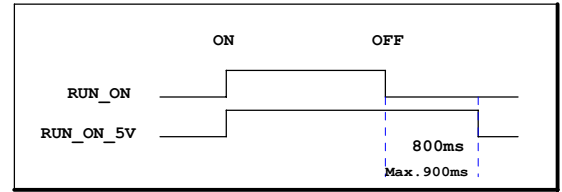
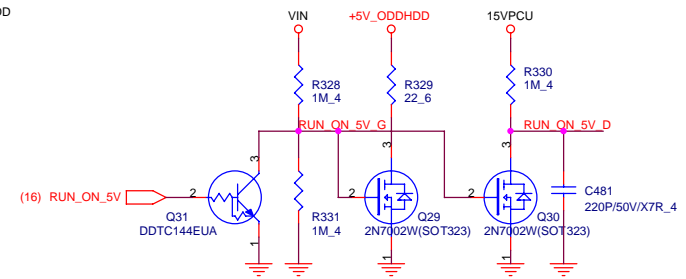
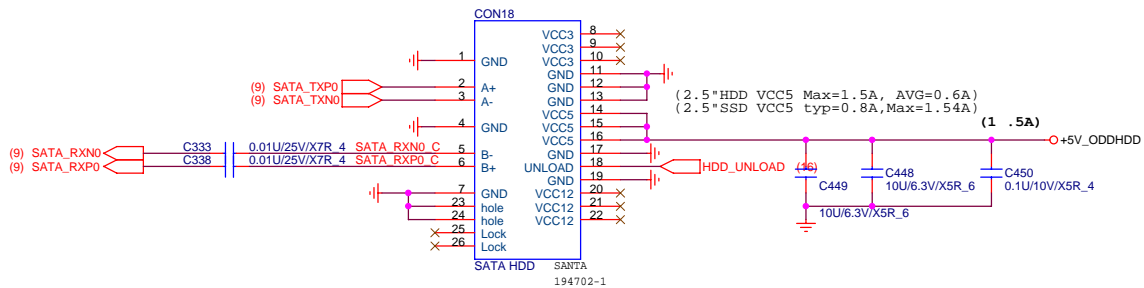

# HDD PROTECT SPI INTERFACE

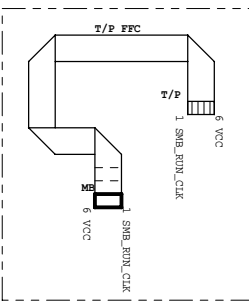
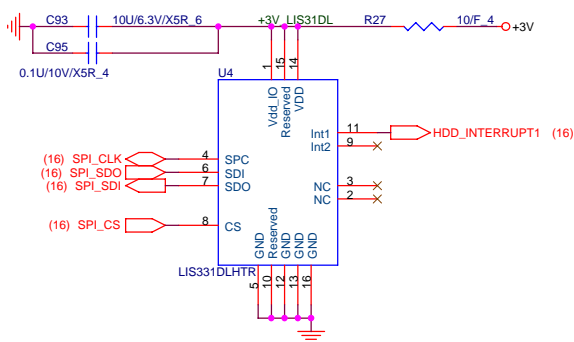

# T/P Board to T/P

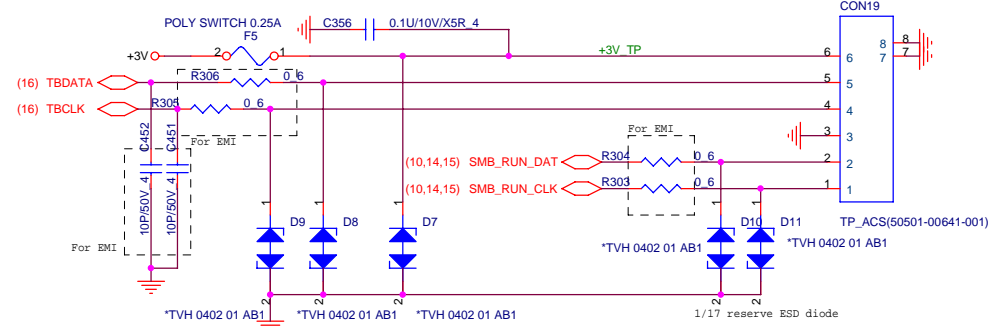

# FAN

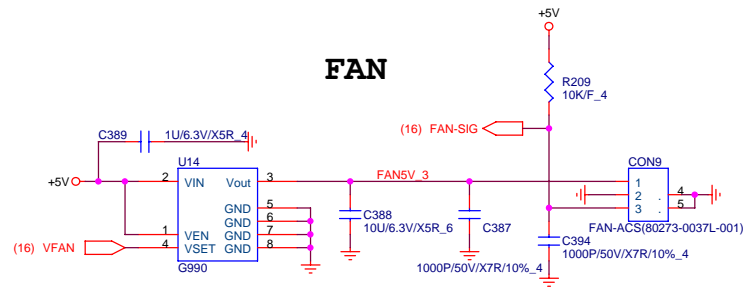

**Quanta Computer Inc.**  
**PROJECT :Chief River**

Size	Document Number	Date	Thursday, January 17, 2013
<b>HDD/ODD/TP/FAN</b>		Sheet	23 of 41
		Rev	1A

1. Level 1 Environment-related Substances Should Never be Used.  
 2. Recycled Resin and Coated Wire should be procured from Green Partners.

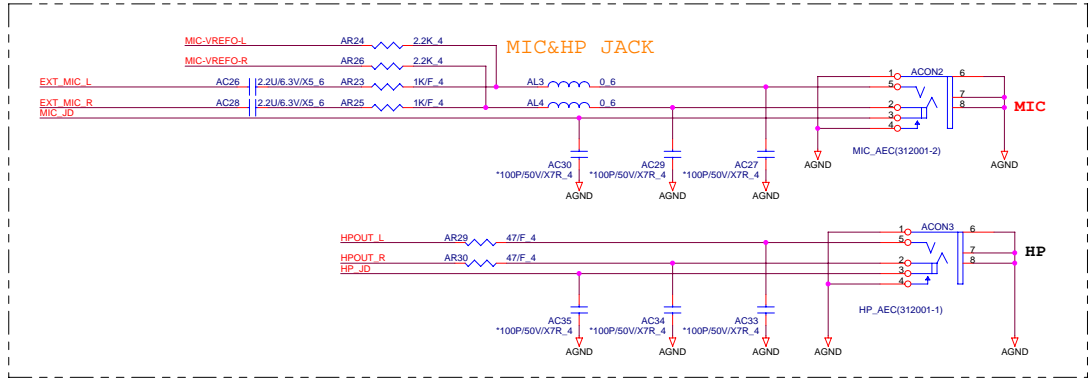
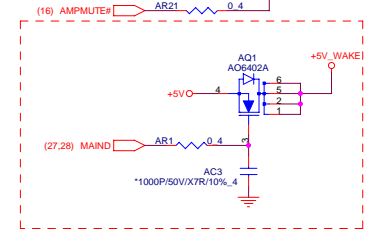
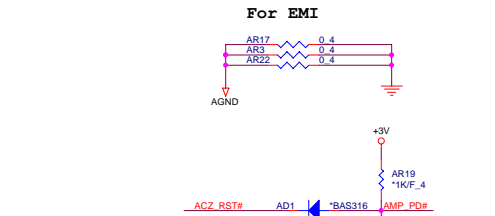
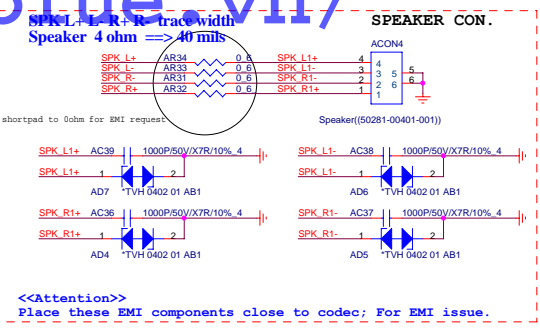
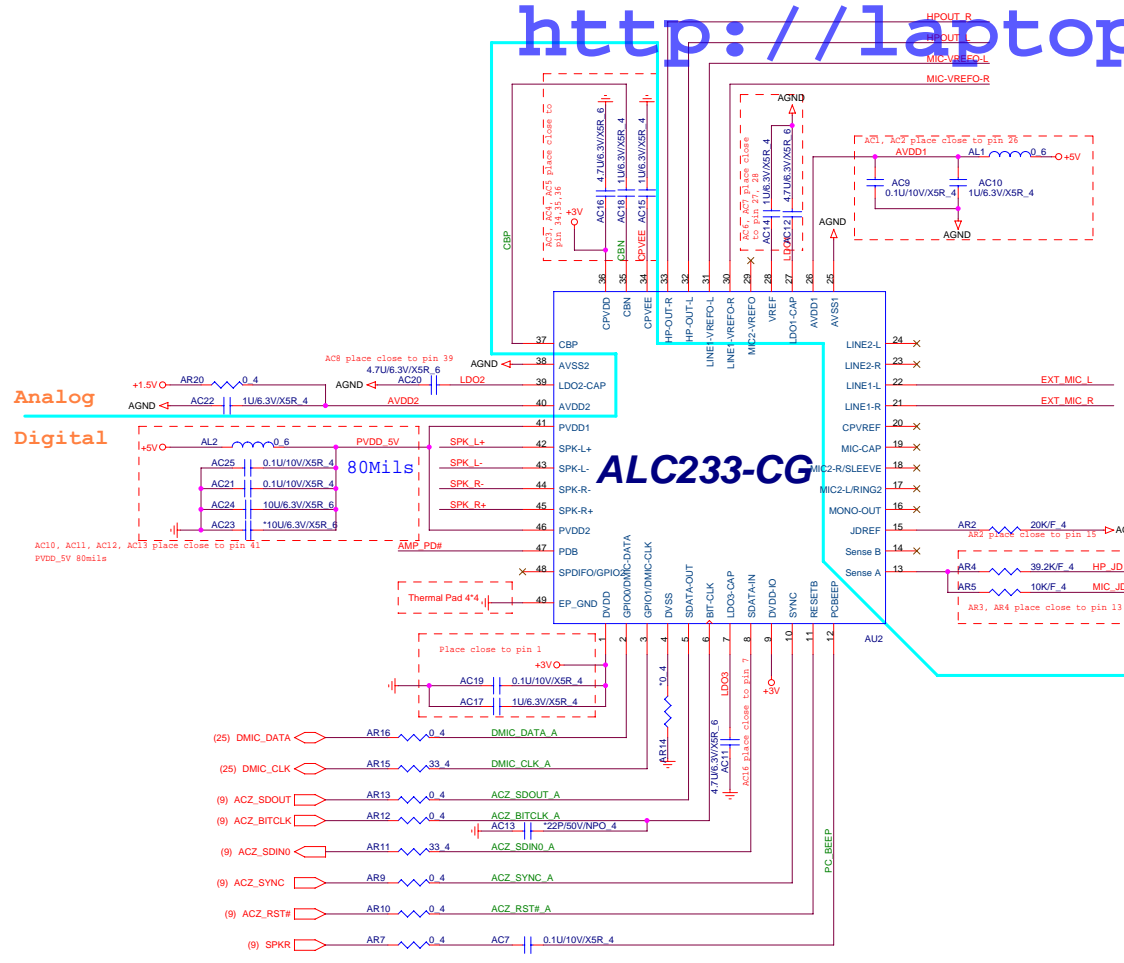

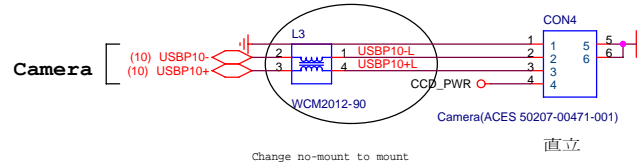
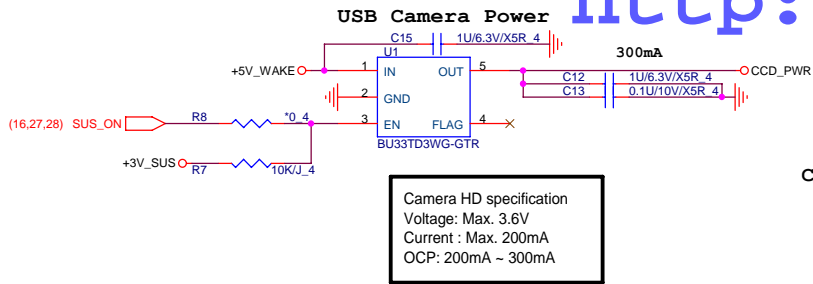

### SATA LED

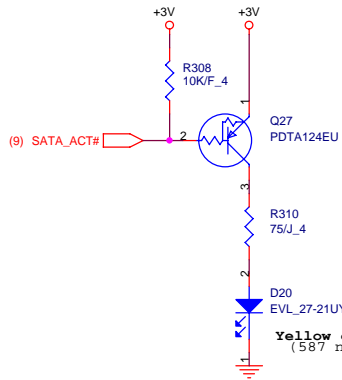

### BATTERY LED

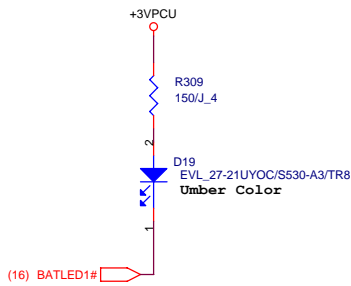

### Power/Sleep LED

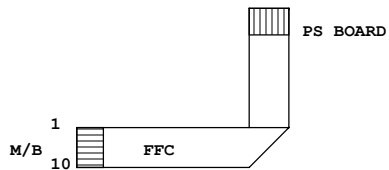
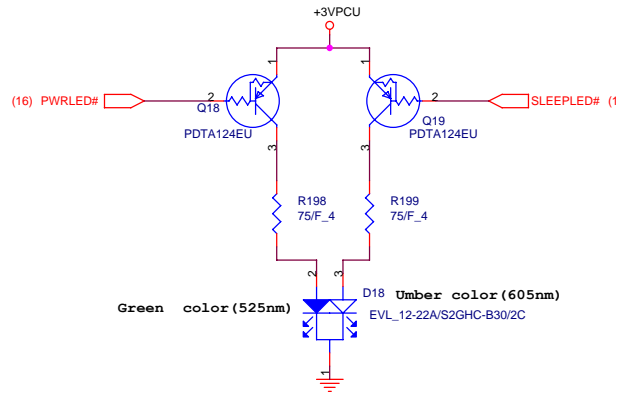

### Power SW Board Connector

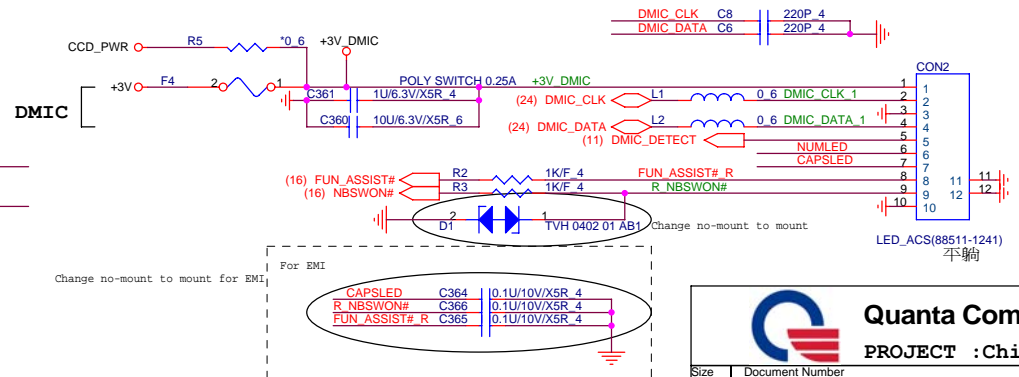
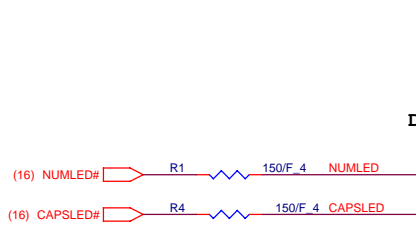

1.Level 1 Environment-related Substances Should Never be Used.  
 2.Recycled Resin and Coated Wire should be procured from Green Partners.

**Quanta Computer Inc.**  
 PROJECT :Chief River

Size	Document Number	LED/RF/KB/PS	Rev 1A
Date:	Thursday, January 17, 2013	Sheet	25 of 41

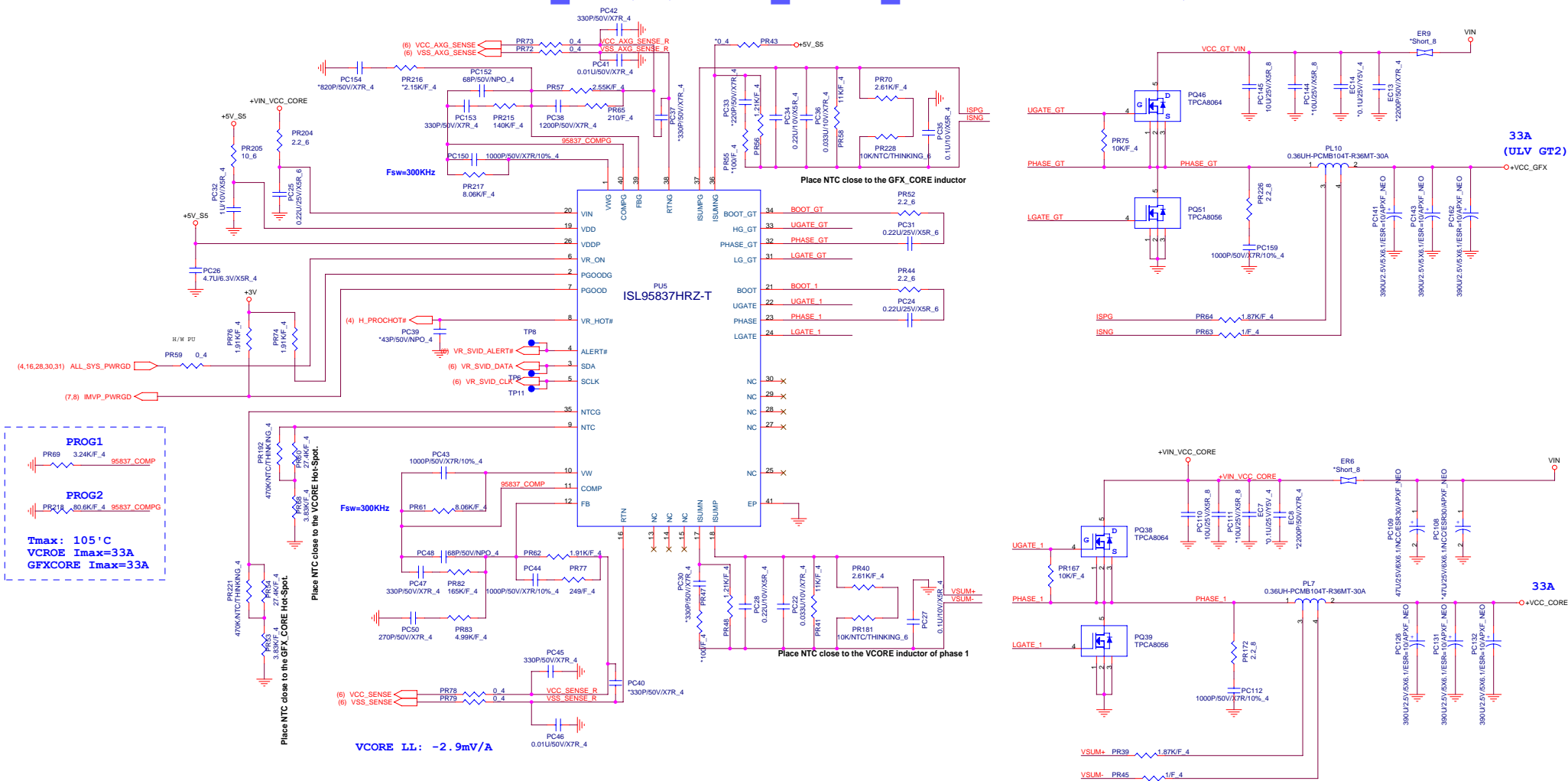

1.Level 1 Environment-related Substances Should Never be Used.  
2.Recycled Resin and Coated Wire should be procured from Green Partners.







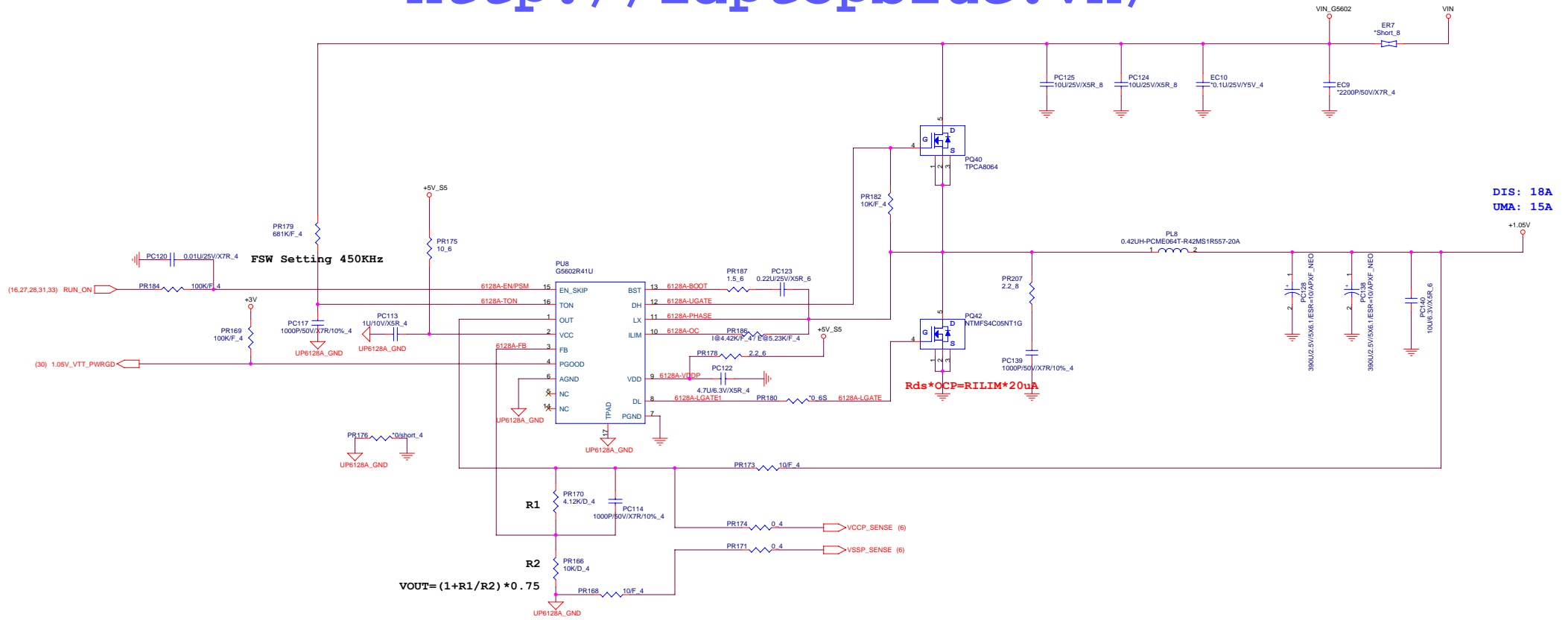

## +VCCSA

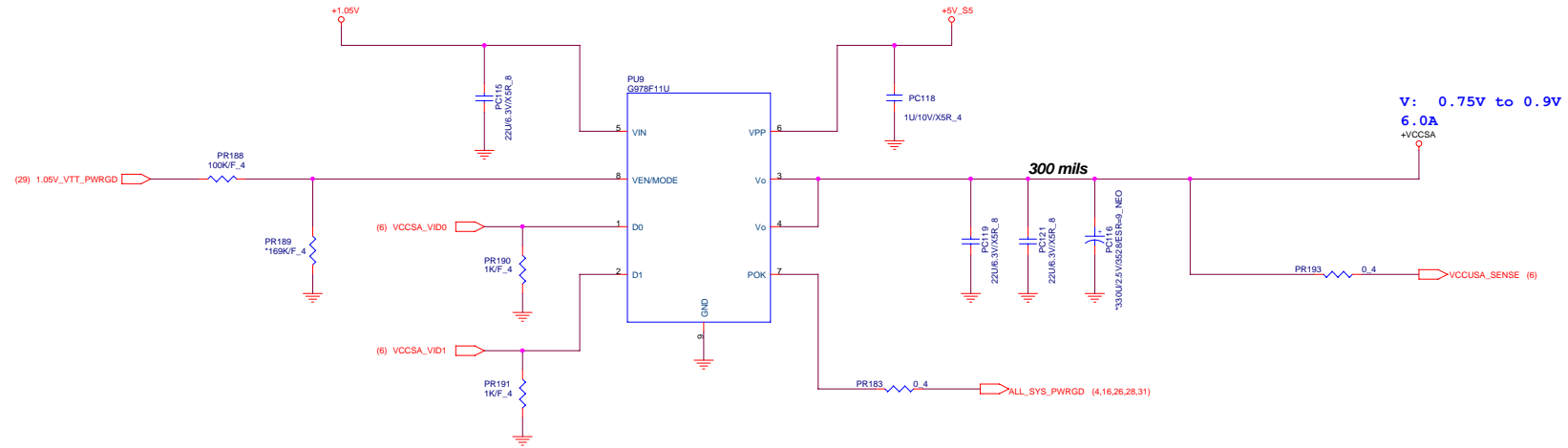

For Chief River ULV

VCCSA_VID0	VCCSA_VID1	+VCCSA
0	0	0.9V
0	1	0.85V
1	0	0.775V
1	1	0.75V

1. Level 1 Environment-related Substances should Never be Used.  
 2. Recycled Resin and Coated Wire should be procured from Green Partners.

VCC1.8

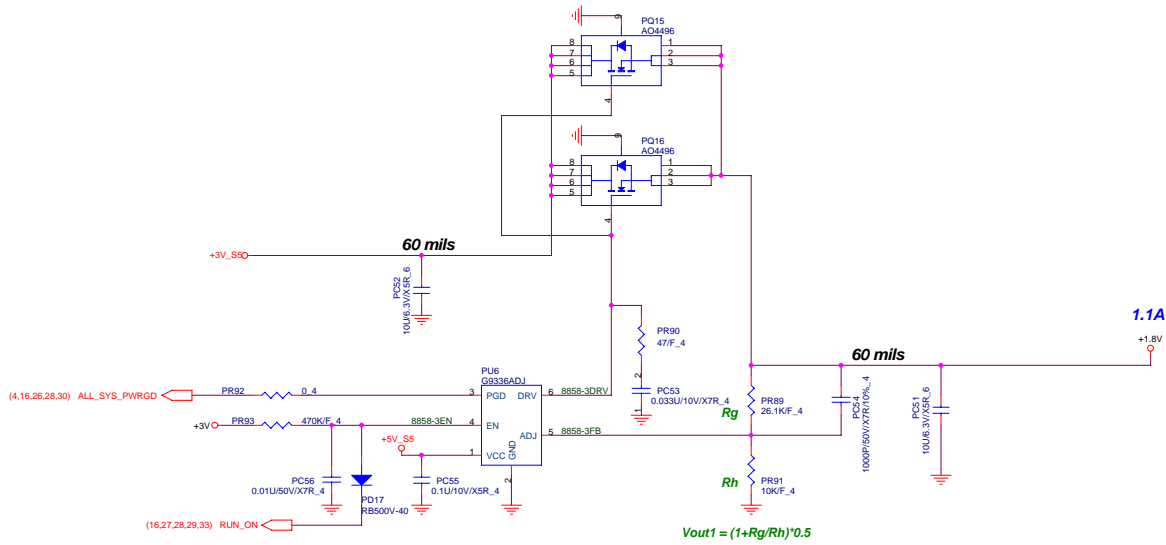

Thermal Protection and Battery UVP for VEDS

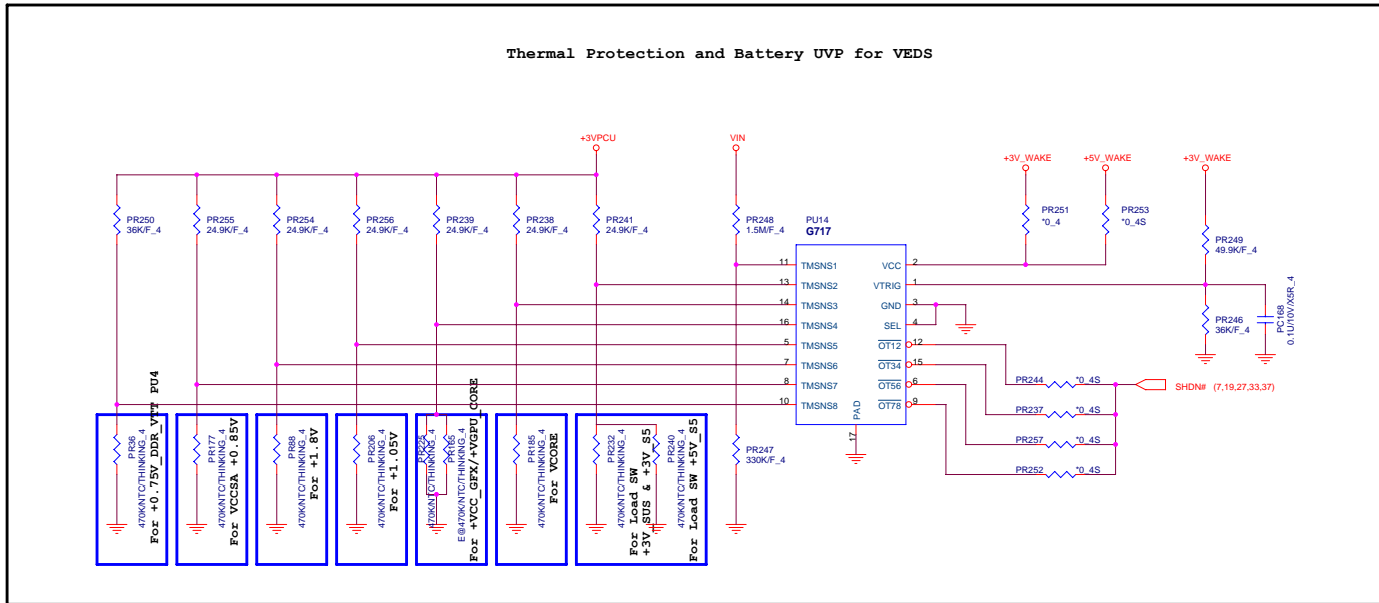







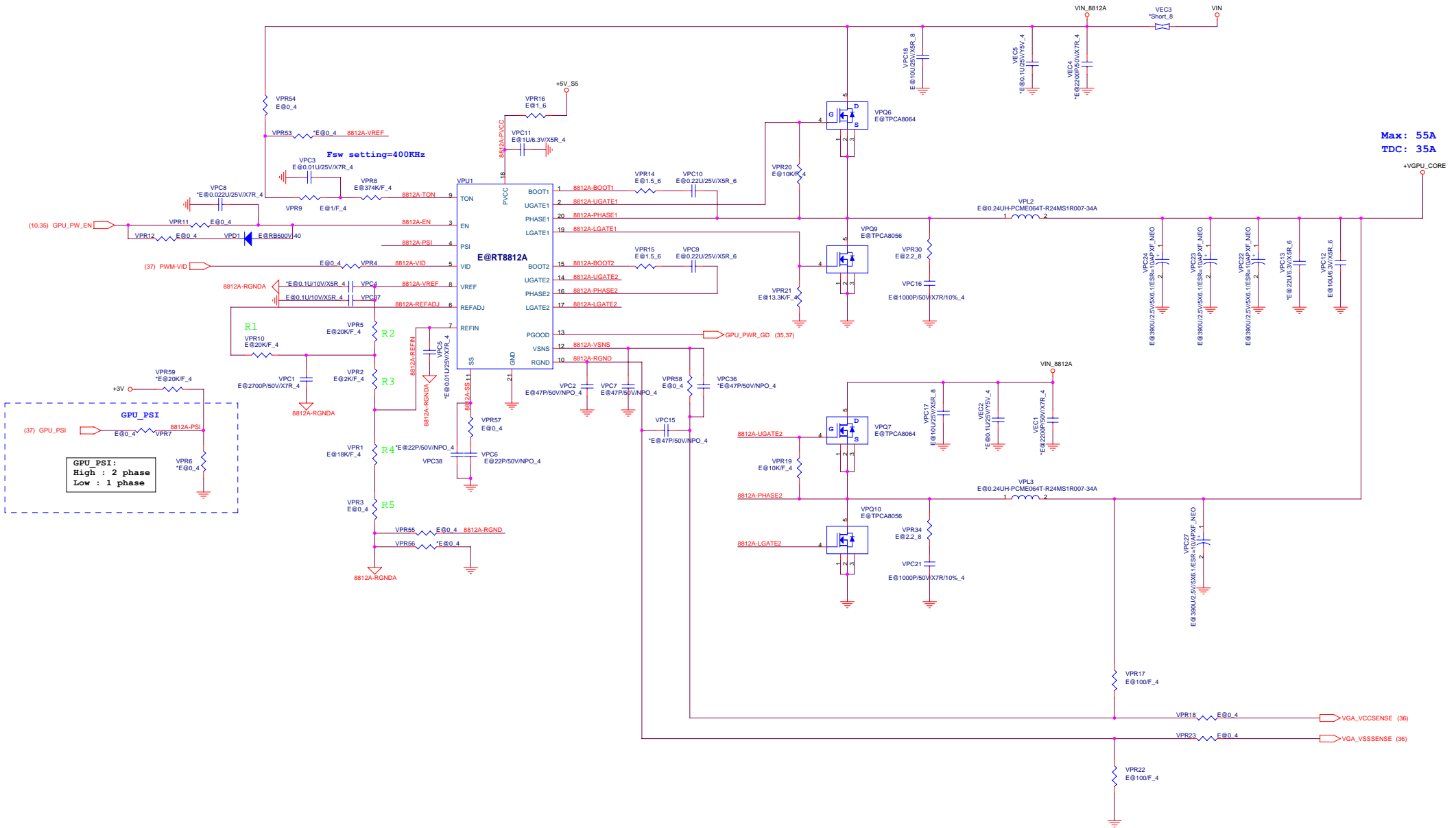

Max : 55A  
TDC : 35A

GPU\_PSI:  
High : 2 phase  
Low : 1 phase

 **Quanta Computer Inc.**  
PROJECT : Chief River

Size	Document Number	Rev
	VGA_CORE (RT8812A)	1A



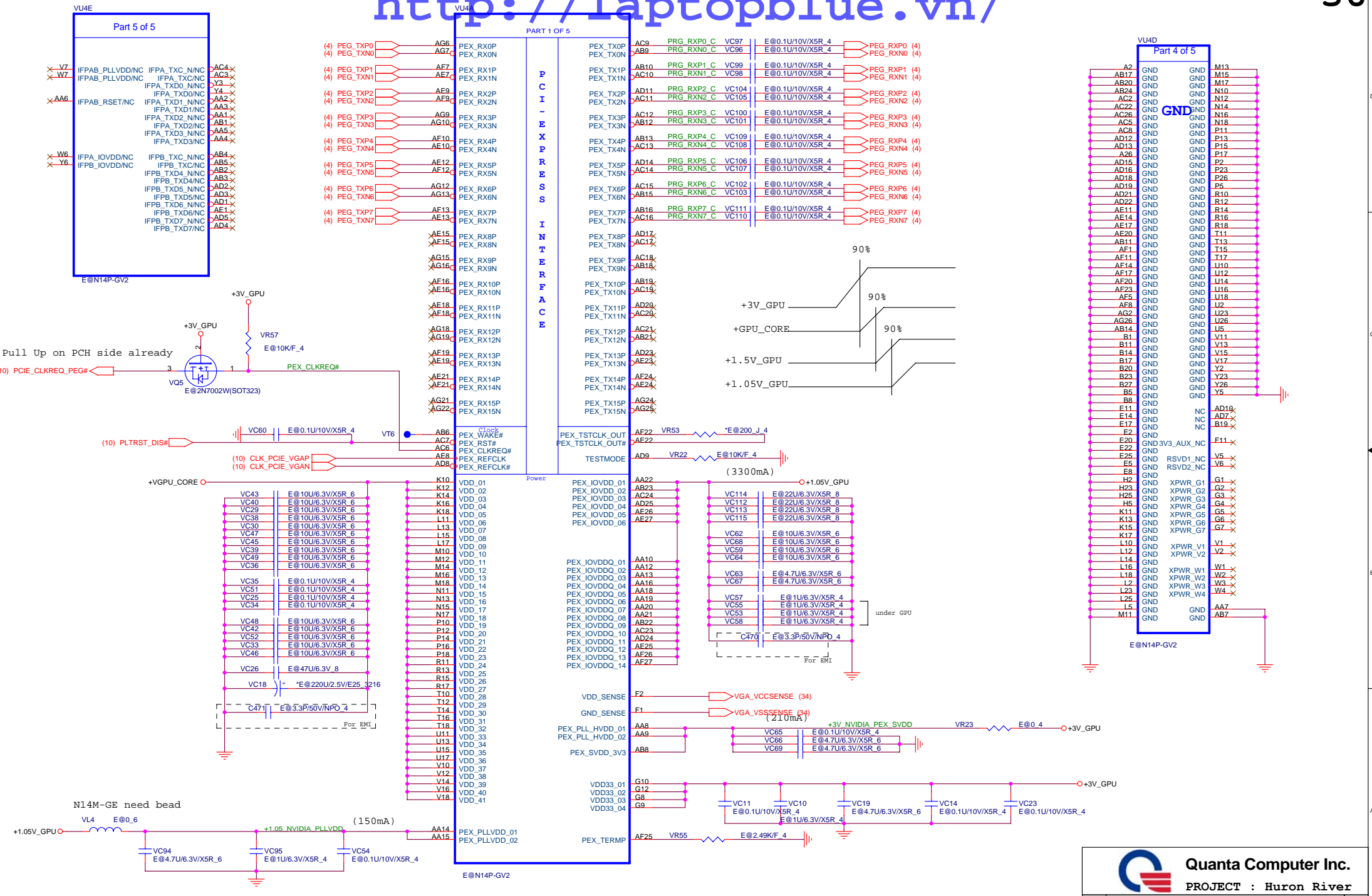

**Quanta Computer Inc.**  
**PROJECT : Huron River**  
 Size Document Number **Nvidia 1/4** Rev 1A  
 1.Level 1 Environment-related Substances Should Never be Used.  
 2.Recycled Resin and Coated Wire should be procured from Green Partners.Date: Thursday, January 17, 2013 Sheet 36 of 41

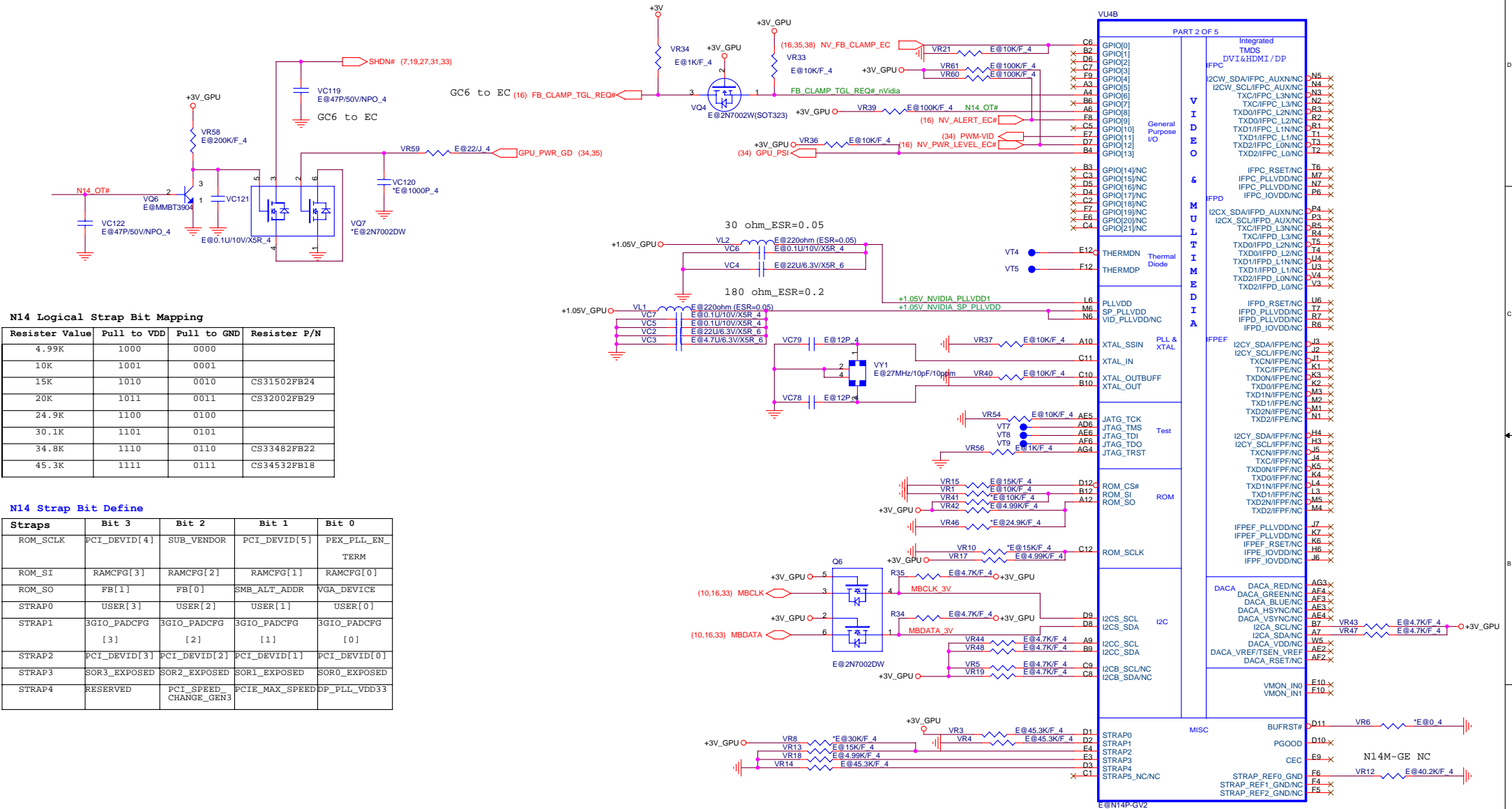

**N14 Logical Strap Bit Mapping**

Resistor Value	Pull to VDD	Pull to GND	Resistor P/N
4.99K	1000	0000	
10K	1001	0001	
15K	1010	0010	CS31502FB24
20K	1011	0011	CS32002FB29
24.9K	1100	0100	
30.1K	1101	0101	
34.8K	1110	0110	CS33482FB22
45.3K	1111	0111	CS34532FB18

**N14 Strap Bit Define**

Straps	Bit 3	Bit 2	Bit 1	Bit 0
ROM_SCLK	PCI_DEVID[4]	SUB_VENDOR	PCI_DEVID[5]	PEX_PLL_EN_TERM
ROM_SI	RAMCFG[3]	RAMCFG[2]	RAMCFG[1]	RAMCFG[0]
ROM_SO	FB[1]	FB[0]	SMB_ALT_ADDR	VGA_DEVICE
STRAP0	USER[3]	USER[2]	USER[1]	USER[0]
STRAP1	3GIO_PADCFG[3]	3GIO_PADCFG[2]	3GIO_PADCFG[1]	3GIO_PADCFG[0]
STRAP2	PCI_DEVID[3]	PCI_DEVID[2]	PCI_DEVID[1]	PCI_DEVID[0]
STRAP3	SOR3_EXPOSED	SOR2_EXPOSED	SOR1_EXPOSED	SOR0_EXPOSED
STRAP4	RESERVED	PCI_SPEED_CHANGE_GEN3	PCI_MAX_SPEED	DP_PLL_VDD33

	VRAM Capacity	VRAM Vender	ID	VR1	Mfr P/N	Quanta P/N
N14M-LP	128Mx16 DDR3	Samsung	0111	PD45.3K	K4W2G1646E-BC11	AKD5MGGT525
		Hynix	0110	PD34.8K	H5TQ2G63DPR-11C	AKD5MGWTW15
N14P-GV2	256Mx16 DDR3	Samsung	0011	PD20K	K4W4G1646B-HC11	AKD5MGWT525
		Hynix	0010 (TBD)	PD15K	H5TC4G63APR-11C	AKD5PGWTW10

**Quanta Computer Inc.**  
**PROJECT : Huron River**  
 Size: Document Number: **Nvidia 2/4** Rev: 1A  
 Date: Thursday, January 17, 2013 Sheet: 37 of 41

1. Level 1 Environment-related Substances Should Never be Used.  
 2. Recycled Resin and Coated Wire should be procured from Green Partners.





TOP

BOT

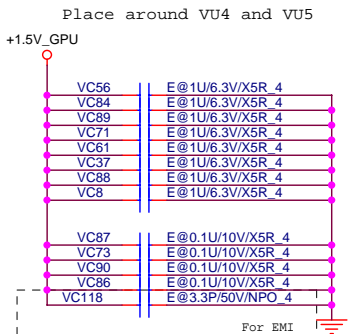
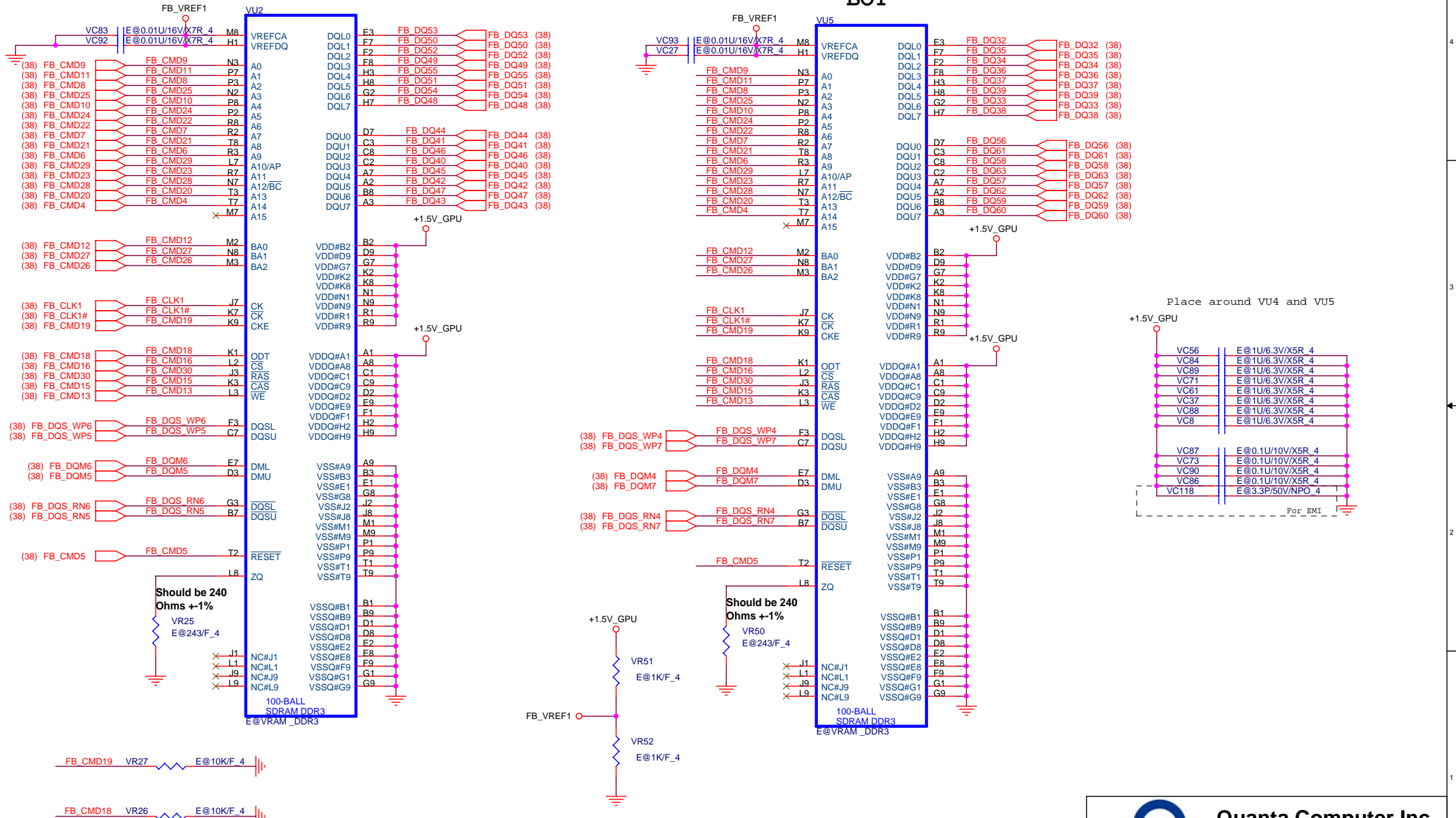

**Quanta Computer Inc.**  
PROJECT : Huron River

Size	Document Number	VRAM 4/4	Rev 1A
Date:	Thursday, January 17, 2013	Sheet 39 of 41	

1. Level 1 Environment-related Substances Should Never be Used.  
2. Recycled Resin and Coated Wire should be procured from Green Partners.



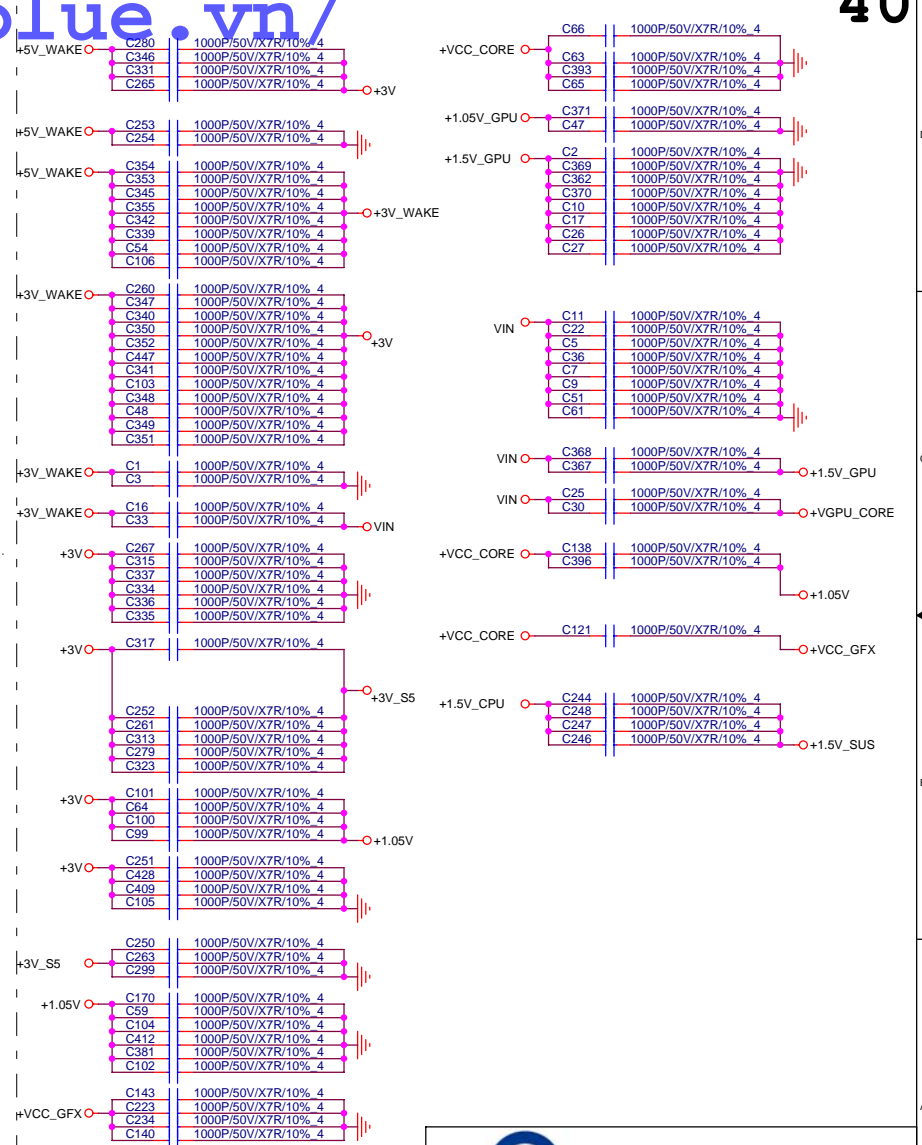
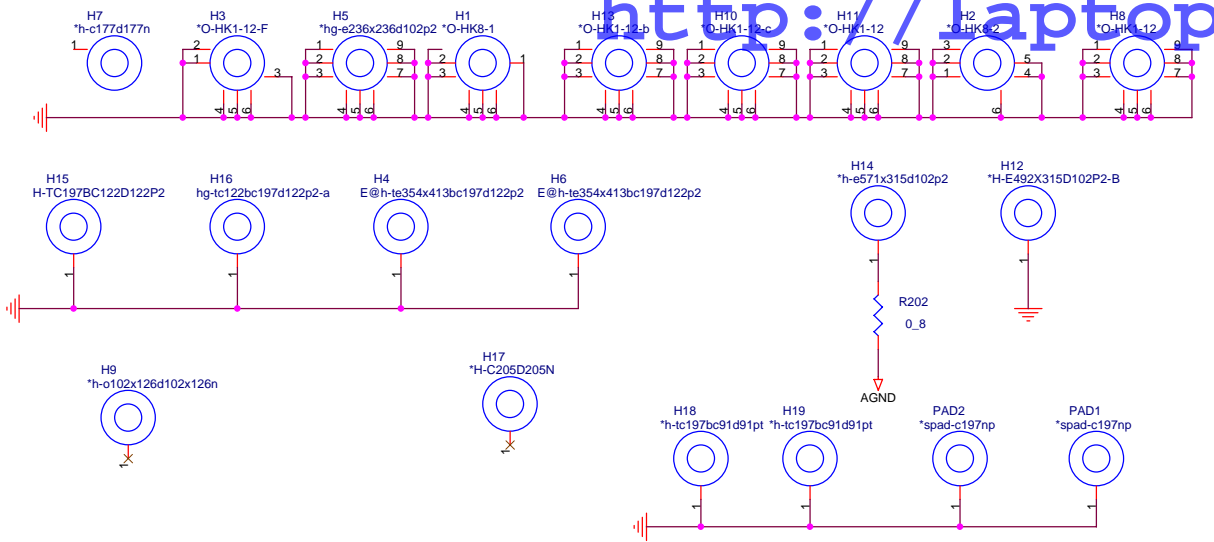

**KEY BOARD Connector**

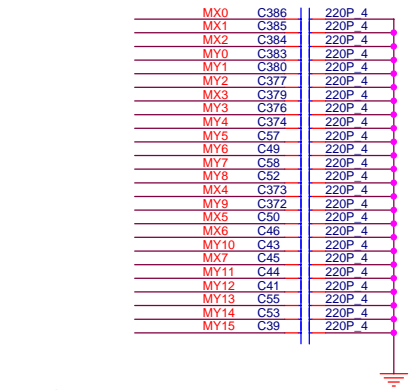
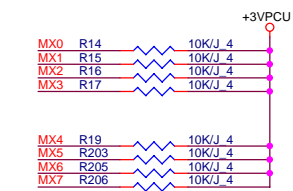
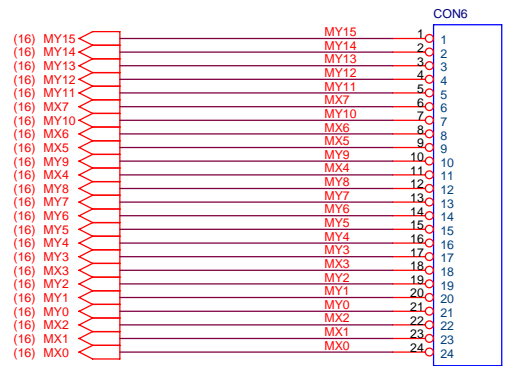

KB(50503-02441-001)

1. Level 1 Environment-related Substances Should Never be Used.  
 2. Recycled Resin and Coated Wire should be procured from Green Partners.

**Quanta Computer Inc.**  
 PROJECT : HK5

Size	Document Number	Rev
	<b>HOLE/EMI/KB</b>	1A
Date:	Thursday, January 17, 2013	Sheet 40 of 41

USB PORT Architecture	
PORT 0	USB3.0
PORT 1	USN3.0
PORT 2	USN2.0
PORT 3	USB2.0
PORT 4	NFC
PORT 5	N/A
PORT 6	N/A
PORT 7	N/A
PORT 8	N/A
PORT 9	WiMax/BT
PORT 10	Camera
PORT 11	Card Reader
PORT 12	Touch Screen
PORT 13	N/A

PCI-E BUS	
PORT 1	WLAN Port
PORT 2	CARD READER
PORT 3	GLAN (RTL8111G)
PORT 4	N/A
PORT 5	N/A
PORT 6	N/A
PORT 7	N/A
PORT 8	N/A

SATA BUS	
PORT 0	HDD
PORT 1	N/A
PORT 2	N/A
PORT 3	N/A
PORT 4	ODD
PORT 5	N/A

SM BUS	MBCLK/MBDATA	WRITE	READ	Function
ISL88731CHRTZ	0001 001X	0001 0010	0001 0011	Charger
Nvidia	1001 1110	-	1001 1110	Graphice
LIS331DL	0011 101X	0011 1010	0011 1011	G Sensor

SM BUS	MBCLK_BAT/MBDATA_BAT	WRITE	READ	Function
VGP-BPS35A	0001 011X	0001 0110	0001 0111	Battery

SM BUS	SMB_PCH_CLK/SMB_PCH_DAT	WRITE	READ	Function
DIMM Module0	1010 000X	1010 0000	1010 0001	DDRIII
DIMM Module 1	1010 010X	1010 0100	1010 0101	DDRIII
Synaptics	0010 110X	0010 1100	0010 1101	Click PAD

	0	1
Board ID0	CaspiCRA1-CaspiCRB1 HK8-HK9	SuperiorCRA1-SuperiorCRB1 GD5-GD6
Board ID1	HK8/GD5 14"	HK9/GD6 15"

PCBA SKU	Discrete	UMA
R280 (Pull High)	Stuff	No Stuff
R279 (Pull Low)	No Stuff	Stuff

	S0	S3	DS3	S4	S5 (Charger Enable)	S5 (Charger Disable)	S5 (Soft OFF) (WoL Disable)	S5 (Soft OFF) (WoL Enable)
<b>RUN_ON</b>	H	L	L	L	L	L	L	L
+3V	H	L	L	L	L	L	L	L
+5V	H	L	L	L	L	L	L	L
+0.75V_DDR_VTT	H	L	L	L	L	L	L	L
+1.05V	H	L	L	L	L	L	L	L
+0.85V	H	L	L	L	L	L	L	L
+1.5V	H	L	L	L	L	L	L	L
+1.8V	H	L	L	L	L	L	L	L
+1.8V_GPU	H	L	L	L	L	L	L	L
+1.0V_GPU	H	L	L	L	L	L	L	L
+VGPU_CORE	H	L	L	L	L	L	L	L
+VCC_GFX	H	L	L	L	L	L	L	L
+VCC_CORE	H	L	L	L	L	L	L	L
<b>SUS_ON</b>	H	H	H	L	L	L	L	L
+1.5V_SUS	H	H	H	L	L	L	L	L
<b>S5_ON</b>	H	H	L	H	L	L	L	H
+5V_S5	H	H	L	H	L	L	L	H
+3V_S5	H	H	L	H	L	L	L	H
<b>EC_WAKE_ON</b>	H	H	H	H	H	L	L	H
+3V_WAKE	H	H	H	H	H	L	L	H
+5V_WAKE	H	H	H	H	H	L	L	H
<b>DEEP_EC_EN</b>	H	H	H	H	L	L	L	L
+3V_S5_DSW	H	H	H	H	L	L	L	L
+3V_SUS	H	H	L	L	L	L	L	L