



Page	Title of schematic page	Rev.	Date
01	Page List	1B	11/12
02	Block Diagram	1B	
03	CPU HT/ CONTROL(1/3)	1B	11/12
04	CPU MEMORY(2/3)	1B	
05	CPU POWER/GND(3/3)	1B	11/30
06	RS880M HT/SPMEM(1/4)	1B	11/12
07	RS880M GFX/PCIE(2/4)	1B	
08	RS880M SYSTEM(3/4)	1B	12/15
09	RS880M POWER(4/4)	1B	
10	SB820M PCI/CLK/LPC(1/4)	1B	12/15
11	SB820M AUDIO/USB(2/4)	1B	12/07
12	SB820M SATA(3/4)	1B	12/07
13	SB820M POWER(4/4)	1B	
14	DDR3 SODIMMX2	1B	12/07
15	CRT/LVDS	1B	11/12
16	HDMI	1B	12/15
17	WLAN/HDD/ODD	1B	11/30
18	CARD READER(RTS5186)	1B	12/15
19	Express Card/LED/BT	1B	12/15
20	Codec(ALC269Q-VB5-GR)	1B	12/07
21	LAN RTL8111E	1B	12/15
22	NPCE781	1B	12/15

Page	Title of schematic page	Rev.	Date
23	KB/USB/FAN/PS	1B	12/03
24	VCORE(ISL6265A)	1B	
25	3VPCU&5VPCU(PM6686)	1B	
26	1.5VSUS/VTT_MEM	1B	
27	DYN_VCC1.1(OZ8116LN)	1B	
28	VCC1.1(OZ8116LN)-7A	1B	
29	VCC1.8/0.9/2.5/1.0	1B	
30	POWER(BAT IN / ADA IN/ UL)	1B	
31	CHARGER (ISL6252A)	1B	
32	SMALL BOARD	1B	11/30
33	POWER SEQUENCE	1B	
34	CHANGE LIST	1B	

1.Level 1 Environment-related Substances Should NEVER be Used.
2.Purchase ink, paint, wire rods, and Molding resins only from the business Partners that Sony approves as Green Partners.



**QUANTA
COMPUTER**

Title **PAGE LIST**

Size B	Document Number AMD	Rev 3A
--------	-------------------------------	-----------

Date: Saturday, March 20, 2010 Sheet 1 of 34

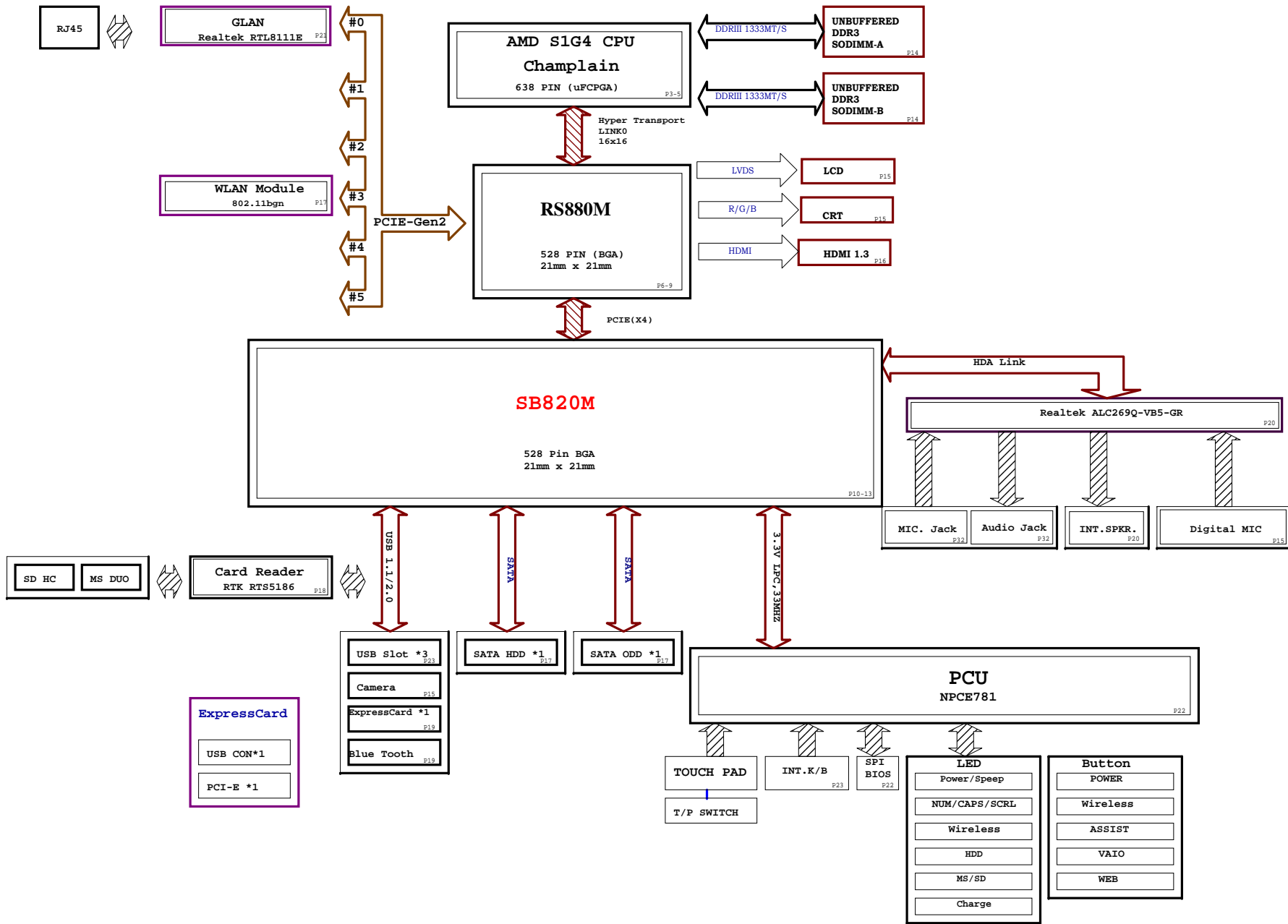

QUANTA COMPUTER

Title: **Block Diagram**

Size: Custom	Document Number: AMD	Rev: 3A
Date: Saturday, March 20, 2010	Sheet: 2 of 34	

1. Level 1 Environment-related Substances Should NEVER be Used.
 2. Purchase link, paint, wire code, and holding resin only from the business Partners that Sony approves as Green Partners.

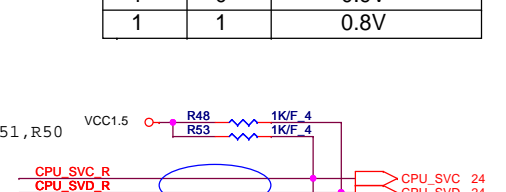
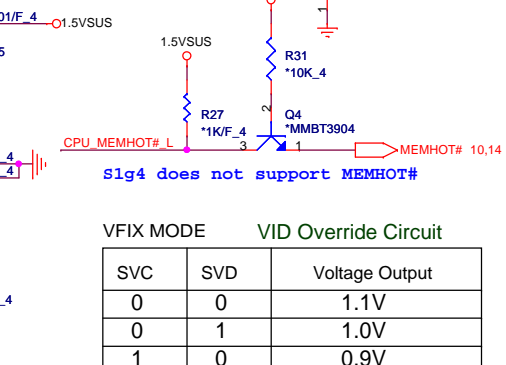
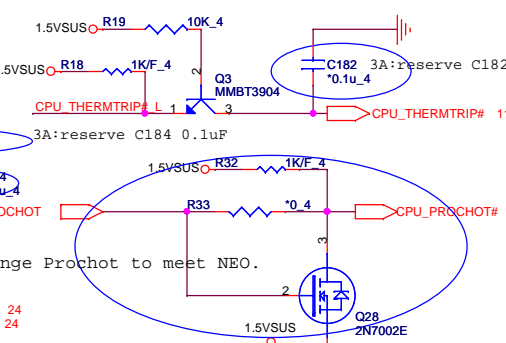
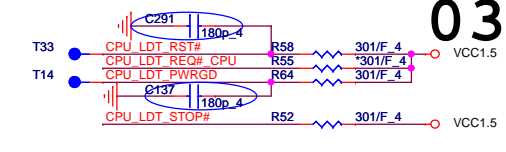
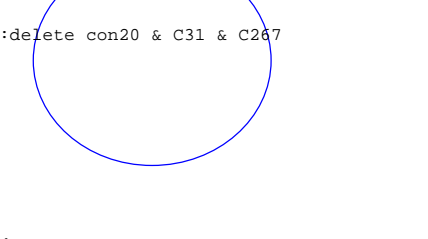
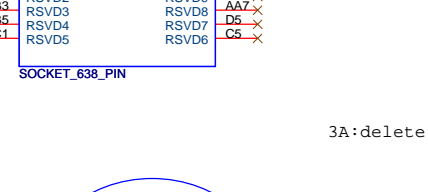
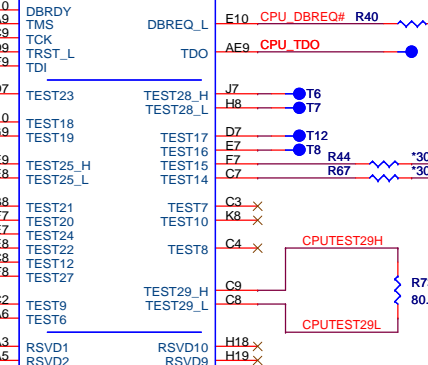
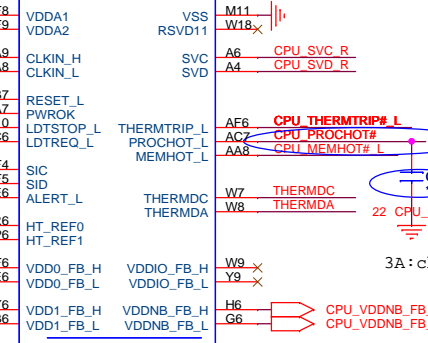
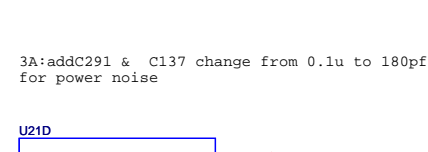
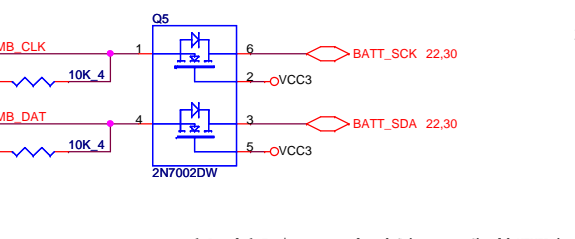
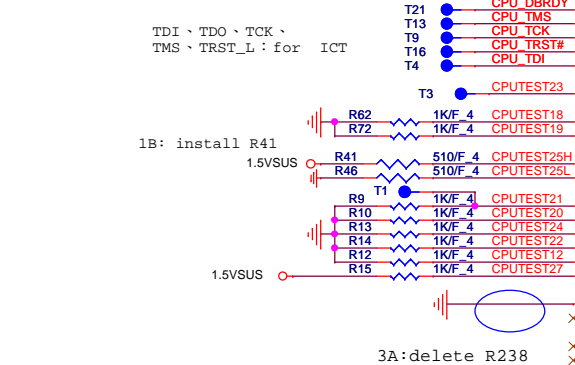
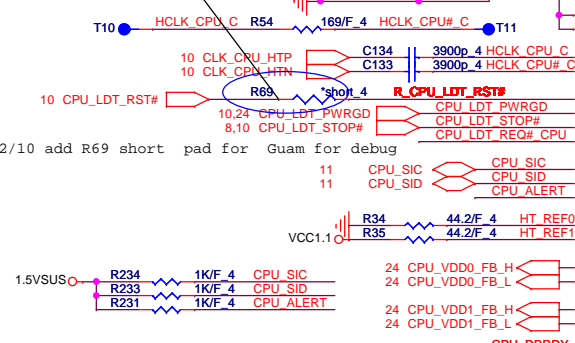
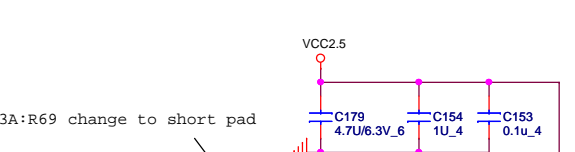
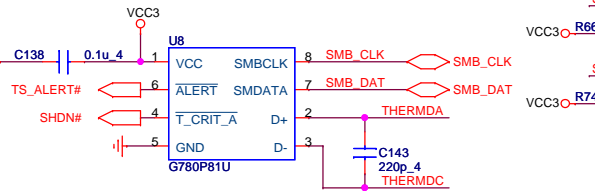
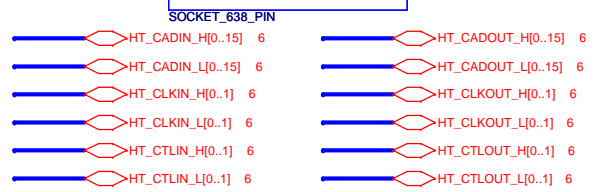
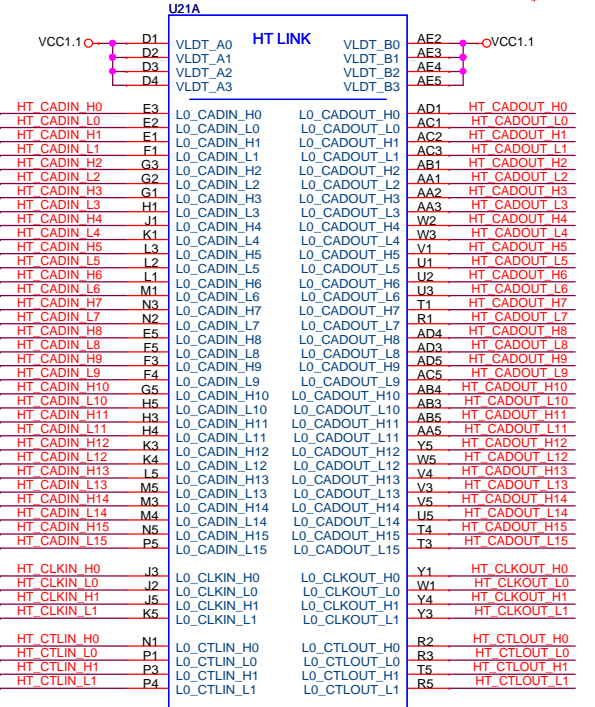
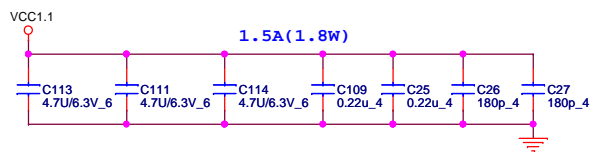

VFIX MODE VID Override Circuit

SVC	SVD	Voltage Output
0	0	1.1V
0	1	1.0V
1	0	0.9V
1	1	0.8V

1.Level 1 Environment-related Substances Should NEVER be Used.
 2.Purchase ink, paint, wire rods, and Molding resins only from the business Partners that Sony approves as Green Partners.

QUANTA COMPUTER

CPU HT/CONTROL(1/3)

Title: CPU HT/CONTROL(1/3)

Size: Custom Document Number: AMD Rev: 3A

Date: Saturday, March 20, 2010 Sheet: 3 of 34

Processor Memory Interface

CPU_VDDR : 35W->0.9V
45W->1.05V

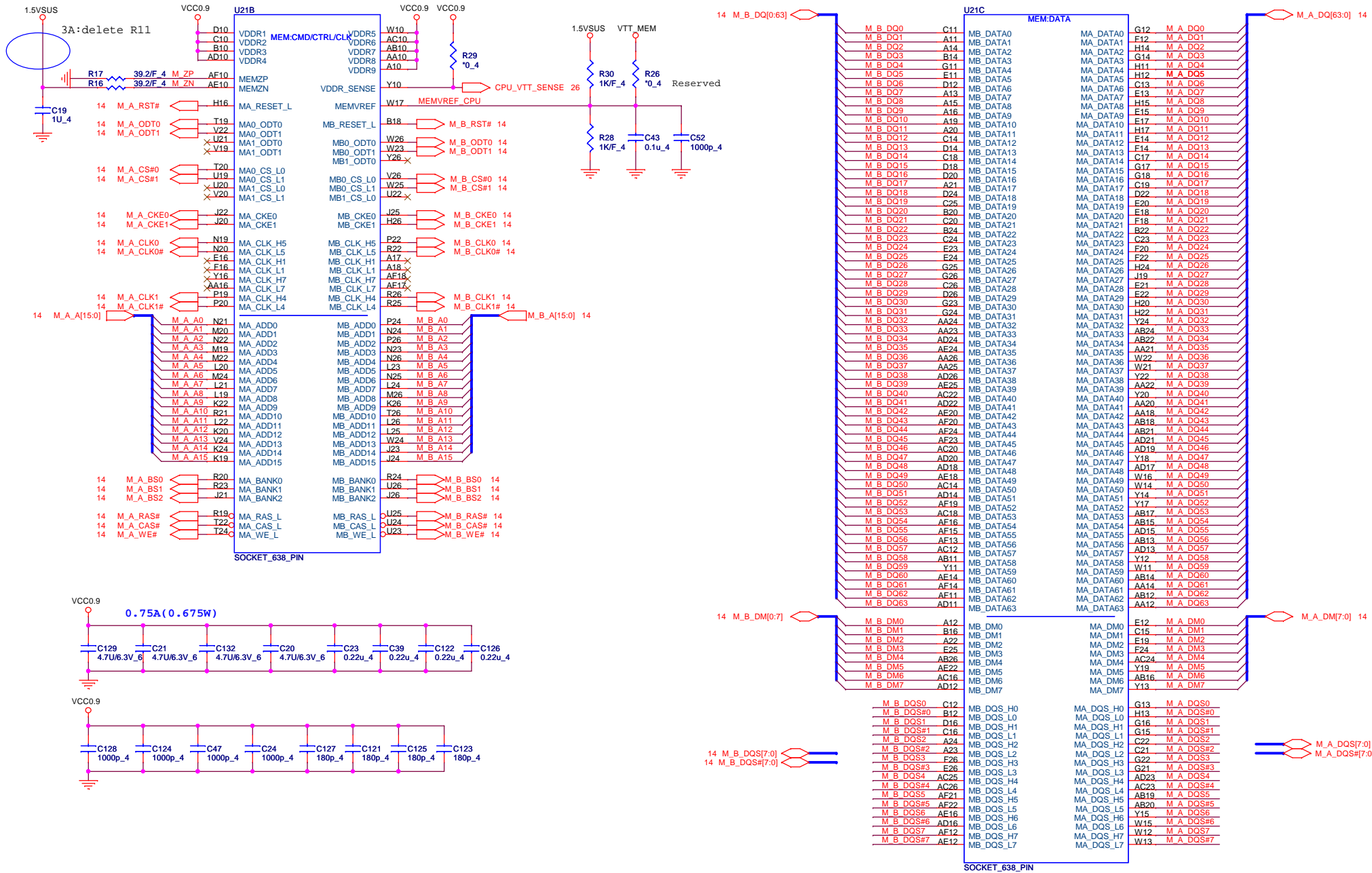

QUANTA COMPUTER

File: **CPU MEMORY(2/3)**

Size: Custom Document Number: **AMD** Rev: 3A

Date: Saturday, March 20, 2010 Sheet: 4 of 34

Socket Type	QCI P/N
Normal	DG0^8000018
90 degree	DG0^8000023

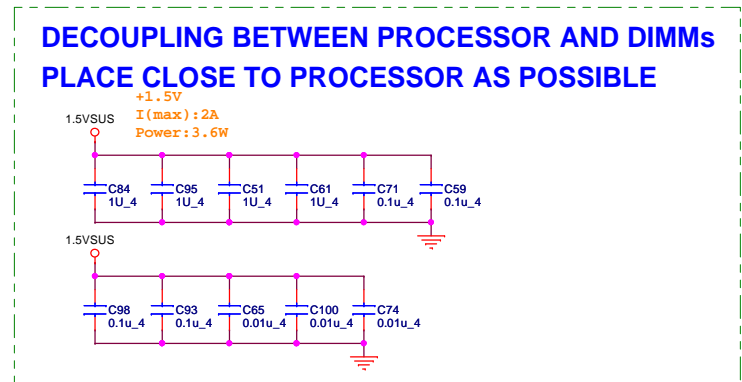
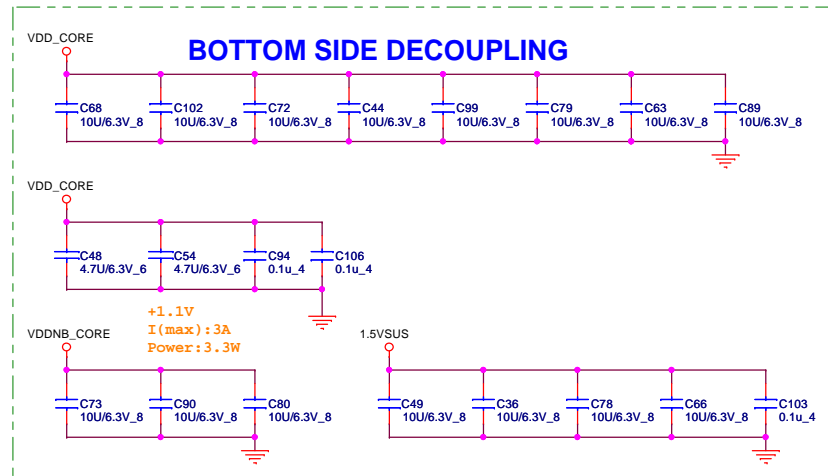
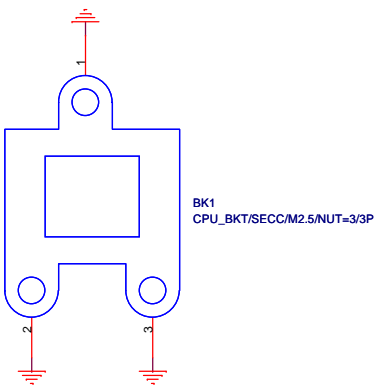
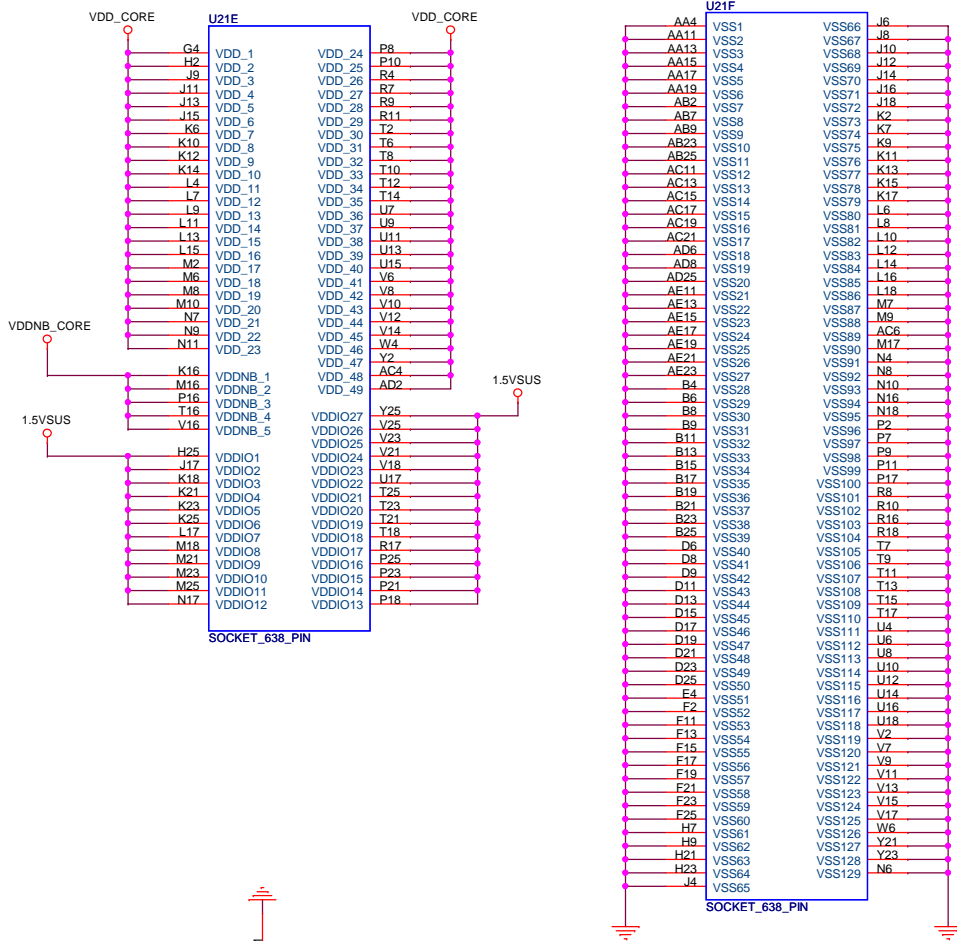

1. Level 1 Environment-related Substances should NEVER be Used.
 2. Purchase ink, paint, wire rods, and Molding resins only from the business Partners that Sony approves as Green Partners.

		QUANTA COMPUTER	
		CPU POWER/GND(3/3)	
Title Size Custom	Document Number AMD	Date Saturday, March 20, 2010	Rev 3A
Sheet 5 of 34			

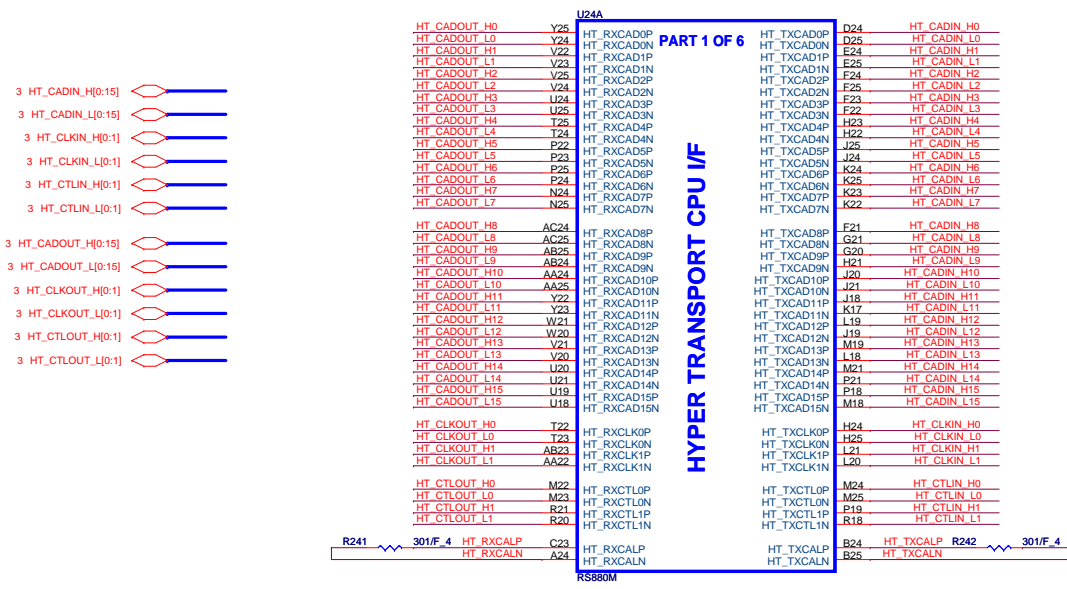

This block is for UMA RS880M only , RX881 can remove all component

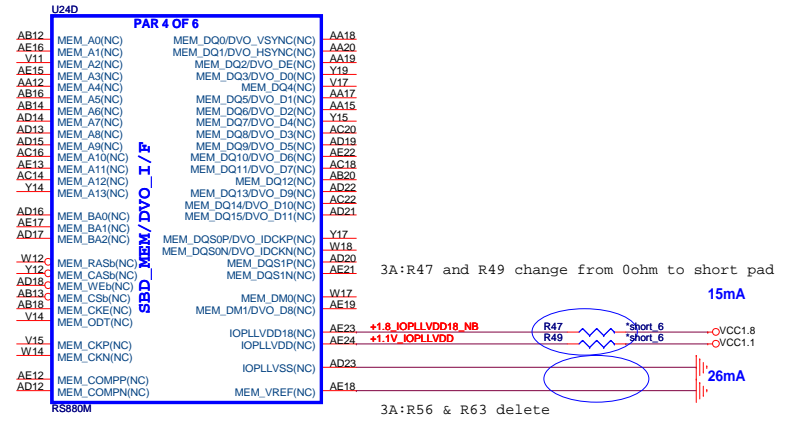

QUANTA COMPUTER

File: **RS880M HT/SPMEM(1/4)**

Size: Custom Document Number: **AMD** Rev: 3A

Date: Saturday, March 20, 2010 Sheet: 6 of 34

U24B

PART 2 OF 6

PCIE I/F GFX

PCIE I/F GPP

PCIE I/F SB

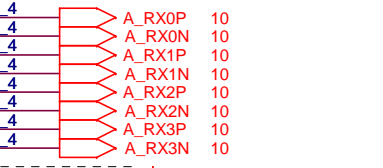
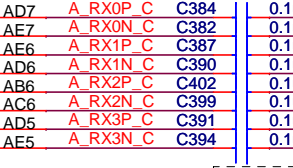
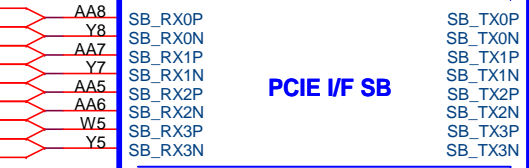
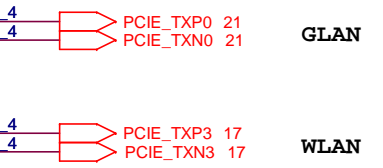
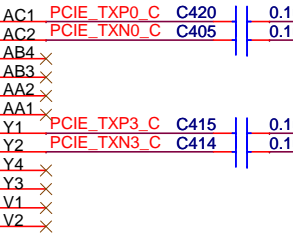
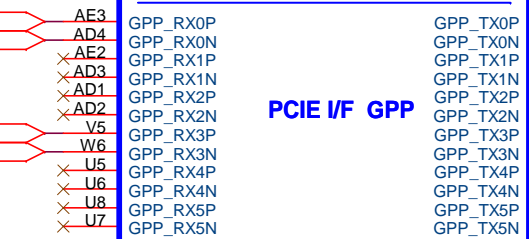
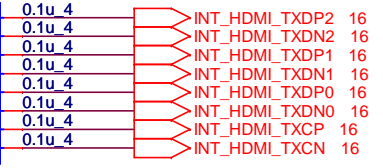
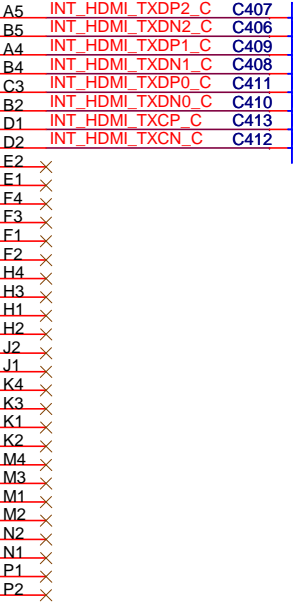
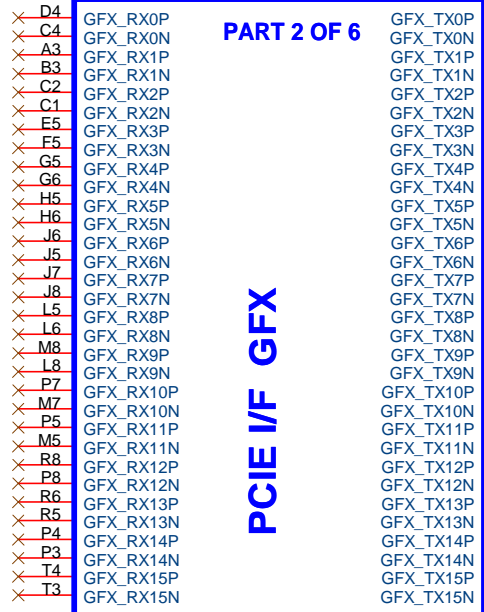

RS880M

PCE_CALRP(PCE_BCALRP)
PCE_CALRN(PCE_BCALRN)

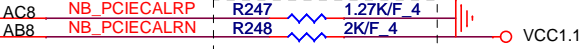

Close NB within 1"

QUANTA COMPUTER

Title: **RS880M GFX/PCIE(2/4)**

Size: Custom	Document Number: AMD	Rev: 3A
Date: Saturday, March 20, 2010	Sheet 7 of 34	

1.Level 1 Environment-related Substances Should NEVER be Used.
 2.Purchase ink, paint, wire rods, and Molding resins only from the business Partners that Sony approves as Green Partners.

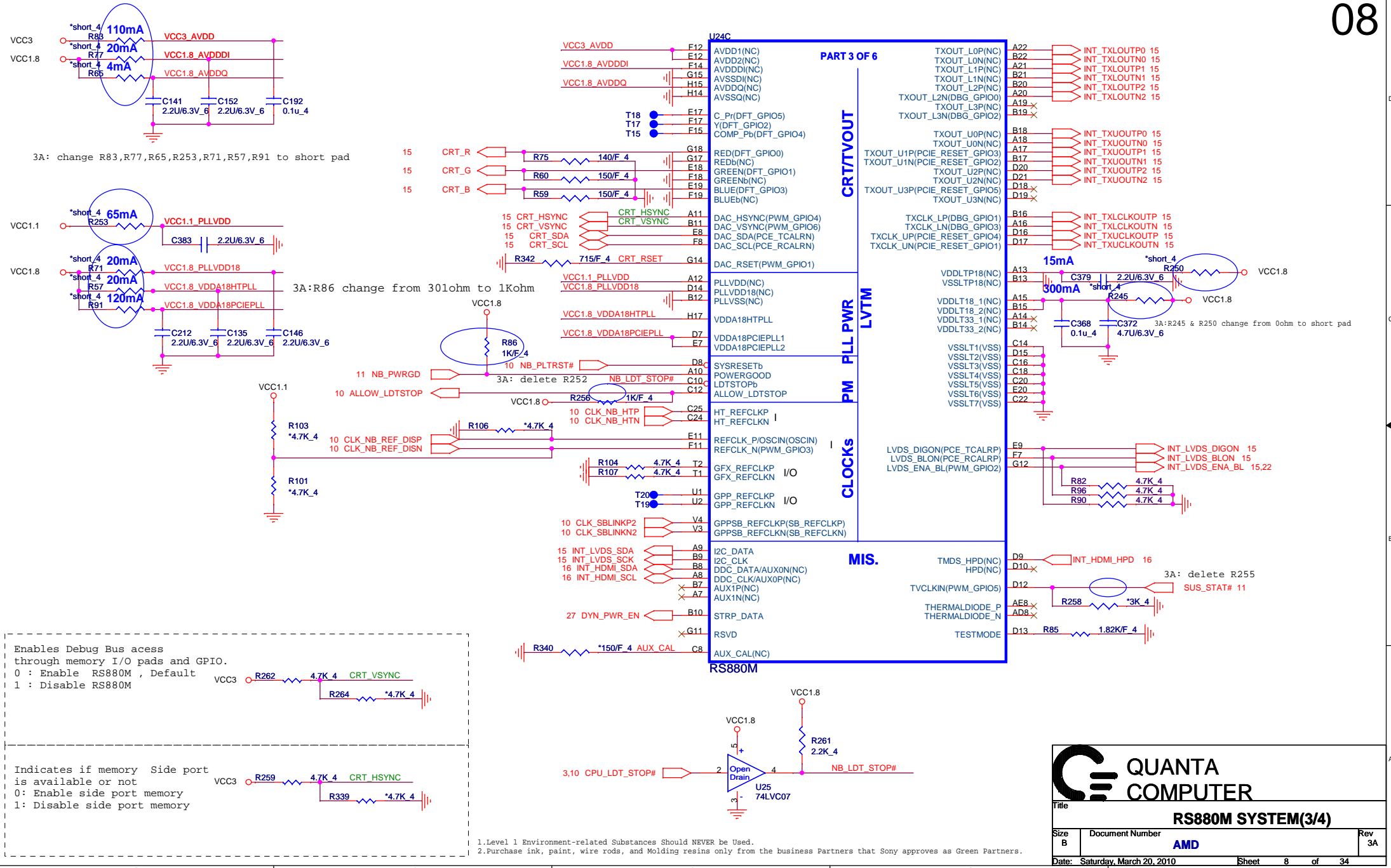

Enables Debug Bus access through memory I/O pads and GPIO.
 0 : Enable RS880M , Default
 1 : Disable RS880M

Indicates if memory Side port is available or not
 0: Enable side port memory
 1: Disable side port memory

1.Level 1 Environment-related Substances Should NEVER be Used.
 2.Purchase ink, paint, wire rods, and Molding resins only from the business Partners that Sony approves as Green Partners.

QUANTA COMPUTER

Title: **RS880M SYSTEM(3/4)**

Size B	Document Number AMD	Rev 3A
Date: Saturday, March 20, 2010		Sheet 8 of 34

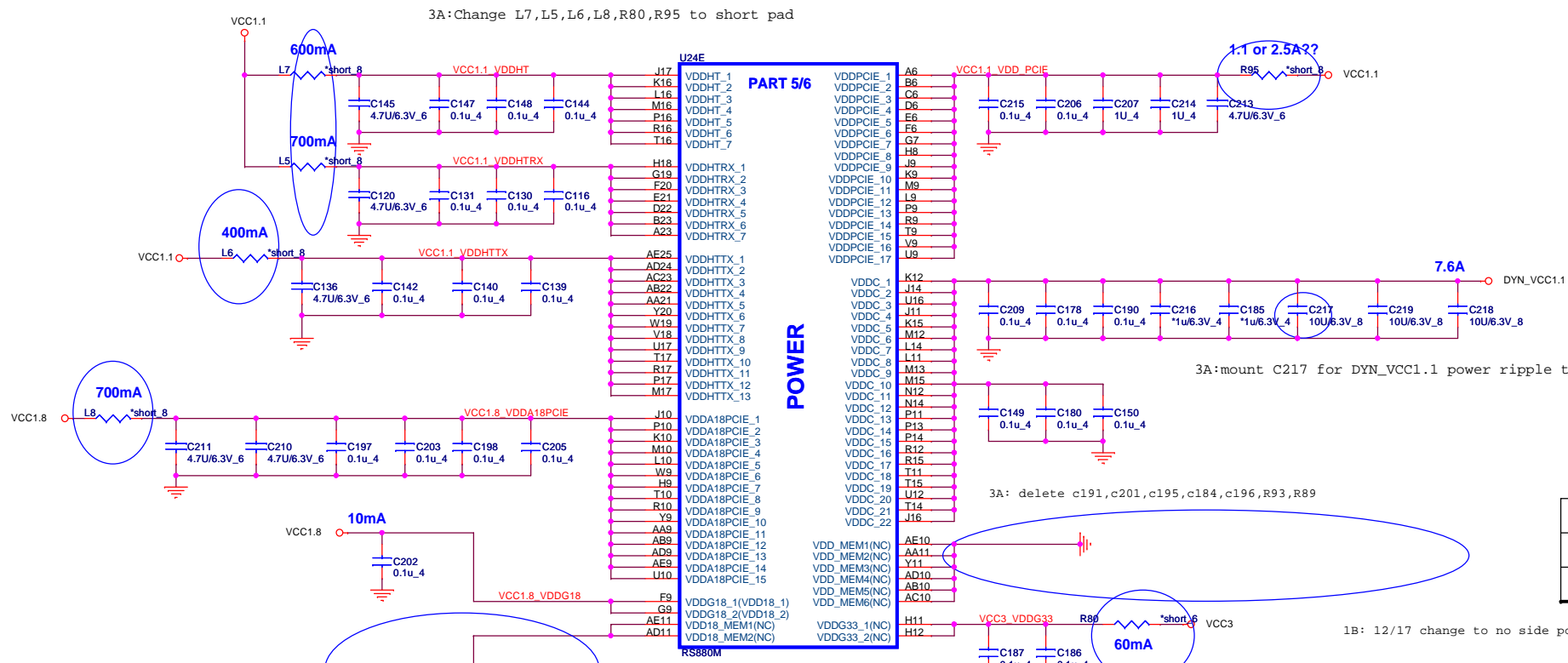
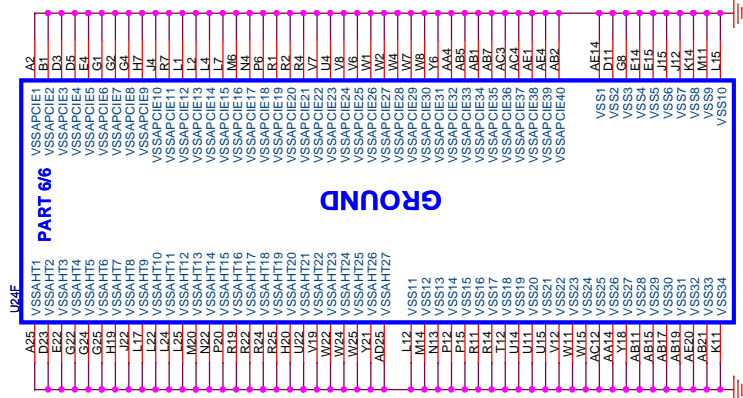

3A: Change L7, L5, L6, L8, R80, R95 to short pad

1.1 or 2.5A??

7.6A

3A: mount C217 for DYN_VCC1.1 power ripple too large

3A: delete c191, c201, c195, c184, c196, r93, r89

1B: 12/17 change to no side port setting

VDD18_MEM	
Side-Port	VCC1.8
No Side-Port	GND

1B: 12/17 change to no side port setting

3A: delete R251, R249, C377

	VDD_MEM
Side-Port	VCC1.5
No Side-Port	GND

QUANTA COMPUTER

Title: **RS880M POWER(4/4)**

Size: Custom	Document Number: AMD	Rev: 3A
Date: Saturday, March 20, 2010	Sheet: 9 of 34	

1. Level 1 Environment-related Substances should NEVER be Used.
 2. Purchase ink, paint, wire rods, and Molding resins only from the business Partners that Sony approves as Green Partners.

Strap Table

1221,AMD suggest R309 unimpunt

PCI_CLK1	PCI_CLK2	PCI_CLK3	PCI_CLK4
ALLOW PCIe Gen2	Watchdog Timer Enable	USE DEBUG STRAPS	non_Fusion CLOCK MODE
FORCE PCIe Gen1	Watchdog Timer Disable	IGNORE DEBUG STRAPS	Fusion CLOCK MODE

PCI Strap

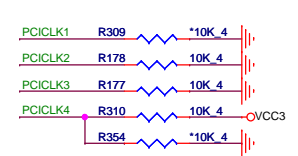

1B: delete no need PU R128/R161/R272/R155, add R354 for optional

RTC

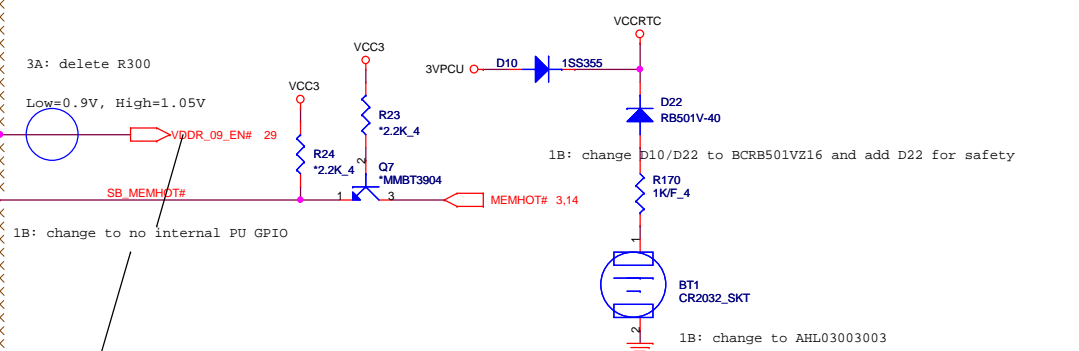

1B: change to AHL03003003

LPCLK0	LPCLK1
H=Enable embedded EC	H=Enable Internal CLK Gen.
L=Disable embedded EC	L=Disable Internal CLK Gen.

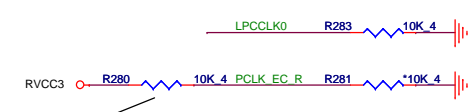

1B: change to INT CLK Gen.

3A:1/22 change Y7 P/N(BG332768909) and C478=18PF for timing accuracy

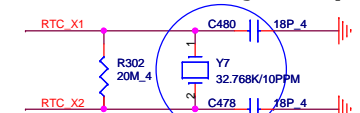

QUANTA COMPUTER

Title: **SB8X0 PCI/CLK/LPC(1/4)**

Size: Custom Document Number: AMD Rev: 3A

Date: Saturday, March 20, 2010 Sheet: 10 of 34

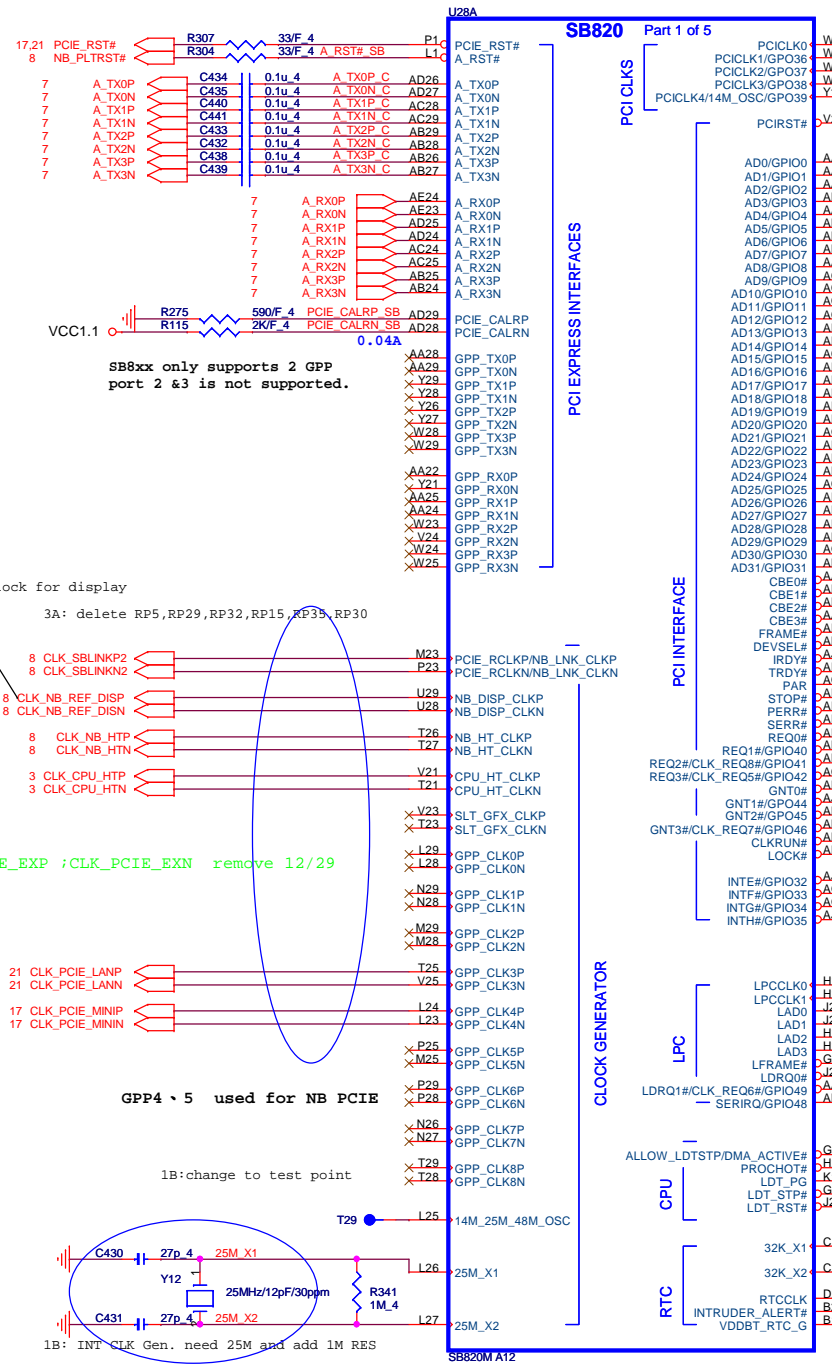

1B: modify INT clock for display

3A: delete RP5,RP29,RP32,RP15,RP35,RP30

CLK_PCIE_EXP ;CLK_PCIE_EXN remove 12/29

GPP4 * 5 used for NB PCIE

1B:change to test point

1B: INT CLK Gen. need 25M and add 1M RES

3A:1/22 change Y12 P/N: BG625000486 and C430=C431 27PF for timing accuracy

1.Level 1 Environment-related Substances Should NEVER be Used.
 2.Purchase ink, paint, wire rods, and Molding resins only from the business Partners that Sony approves as Green Partners.

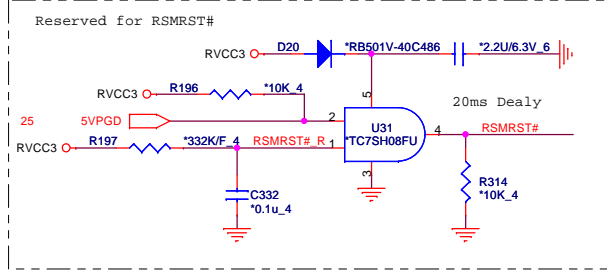
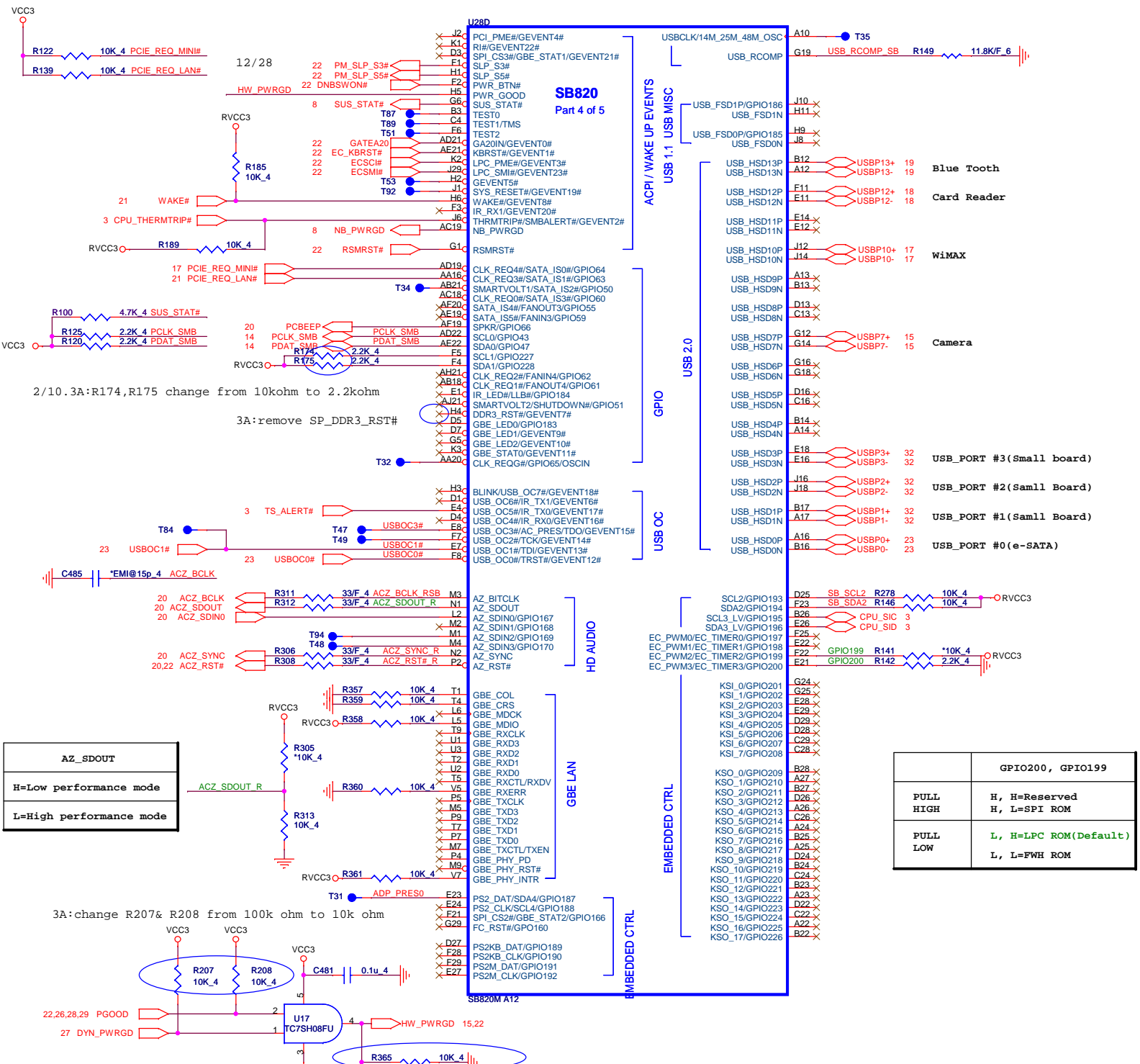

GPIO200, GPIO199	
PULL HIGH	H, H=Reserved H, L=SPI ROM
PULL LOW	L, H=LPC ROM(Default) L, L=FWH ROM

AZ_SDOUT	
H=Low performance mode	
L=High performance mode	

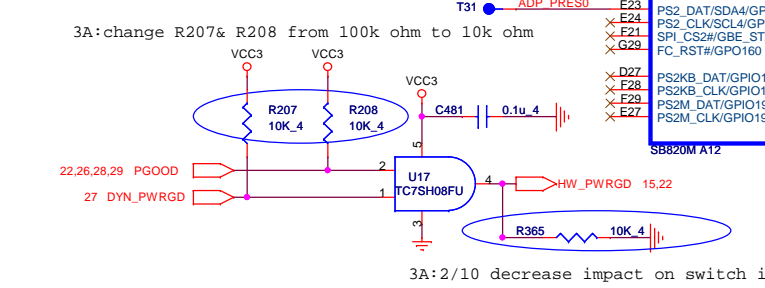

3A:2/10 decrease impact on switch issue

1.Level 1 Environment-related Substances should NEVER be used.
2.Purchase ink, paint, wire rods, and Molding resins only from the business Partners that Sony approves as Green Partners.

QUANTA COMPUTER

Title: **SB8X0 AUDIO/USB(3/4)**

Size: Custom Document Number: AMD Rev: 3A

Date: Saturday, March 20, 2010 Sheet: 11 of 34

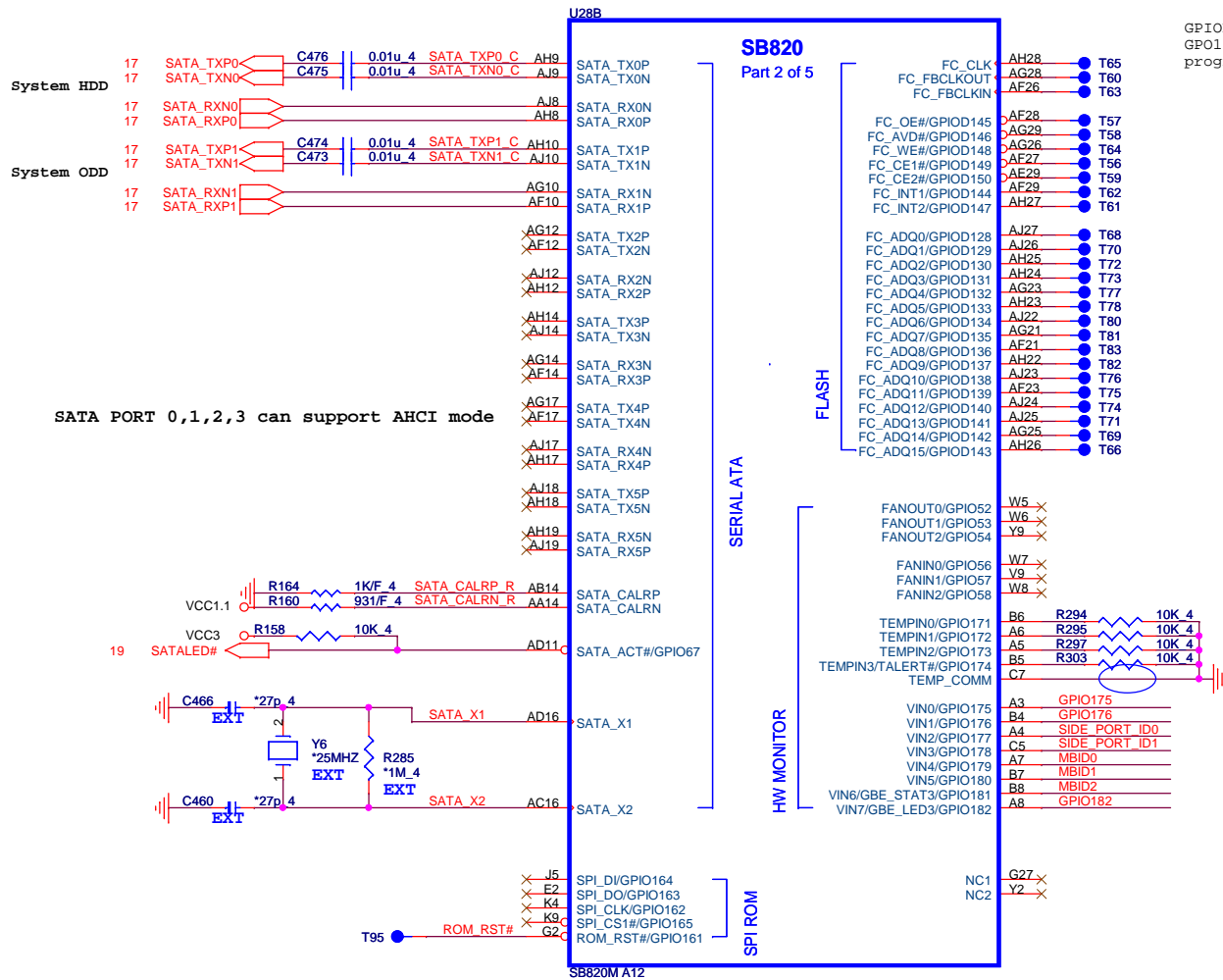

GPIO[150:128] are open drain GPIO pins where as GPIO160 is an open drain GPO pin. These pins are not programmed to GPIO mode by default.

ID2	ID1	ID0	
0	0	0	Danube UMA
0	0	1	Danube UMA+Side port
0	1	0	Danube+Park XT
0	1	1	Danube+Madison LP
1	0	0	Danube+M92 XTX
1	0	1	
1	1	0	
1	1	1	

	NON	SAMSUNG	HYNIX	
SP ID0	0	1	0	1
SP ID1	0	0	1	1

3A:delete R176

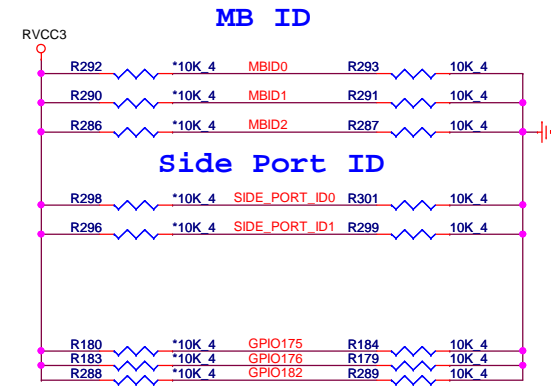

1.Level 1 Environment-related Substances Should NEVER be Used.
2.Purchase ink, paint, wire rods, and Molding resins only from the business Partners that Sony approves as Green Partners.

QUANTA COMPUTER

Title: **SB8X0 SATA(2/4)**

Size B Document Number: **AMD** Rev 3A

Date: Saturday, March 20, 2010 Sheet 12 of 34

3A:Change R187,L10,L9,L15,L13,L18,L18,R169,L12,L11,L19,L14,L17,R127,R284,L26,R145 to short pad

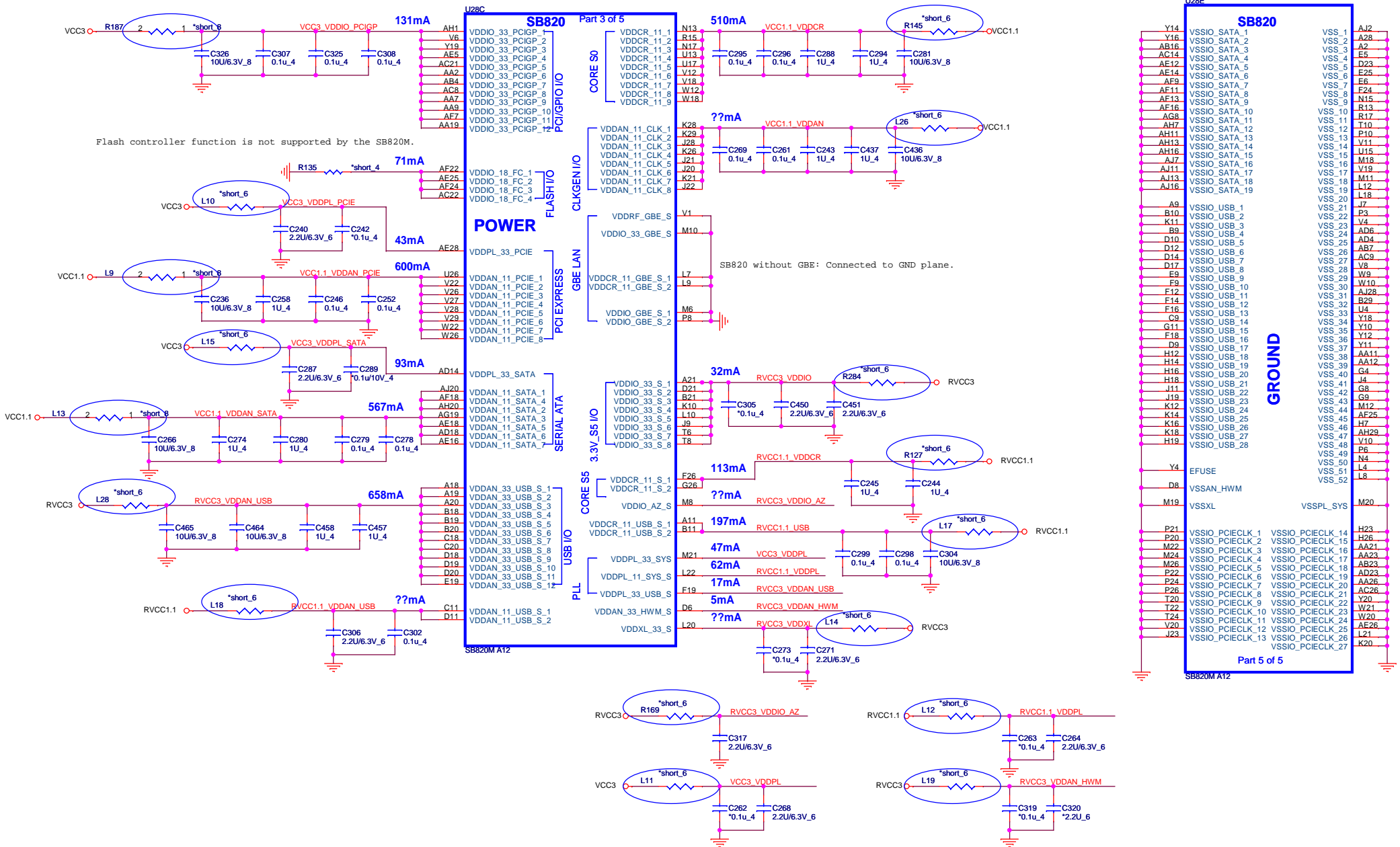

Flash controller function is not supported by the SB820M.

SB820 without GBB: Connected to GND plane.

GROUND

SB820		
Y14	VSSIO_SATA_1	VSS_1
Y16	VSSIO_SATA_2	VSS_2
AB16	VSSIO_SATA_3	VSS_3
AC14	VSSIO_SATA_4	VSS_4
AE12	VSSIO_SATA_5	VSS_5
AE14	VSSIO_SATA_6	VSS_6
AF9	VSSIO_SATA_7	VSS_7
AF11	VSSIO_SATA_8	VSS_8
AF13	VSSIO_SATA_9	VSS_9
AF16	VSSIO_SATA_10	VSS_10
AG8	VSSIO_SATA_11	VSS_11
AH7	VSSIO_SATA_12	VSS_12
AH11	VSSIO_SATA_13	VSS_13
AH13	VSSIO_SATA_14	VSS_14
AH16	VSSIO_SATA_15	VSS_15
AJ7	VSSIO_SATA_16	VSS_16
AJ11	VSSIO_SATA_17	VSS_17
AJ13	VSSIO_SATA_18	VSS_18
AJ16	VSSIO_SATA_19	VSS_19
A9	VSSIO_USB_1	VSS_20
D10	VSSIO_USB_2	VSS_21
K11	VSSIO_USB_3	VSS_22
B9	VSSIO_USB_4	VSS_23
D10	VSSIO_USB_5	VSS_24
D12	VSSIO_USB_6	VSS_25
D14	VSSIO_USB_7	VSS_26
D17	VSSIO_USB_8	VSS_27
E9	VSSIO_USB_9	VSS_28
F9	VSSIO_USB_10	VSS_29
F12	VSSIO_USB_11	VSS_30
F14	VSSIO_USB_12	VSS_31
F16	VSSIO_USB_13	VSS_32
G9	VSSIO_USB_14	VSS_33
G11	VSSIO_USB_15	VSS_34
F18	VSSIO_USB_16	VSS_35
D9	VSSIO_USB_17	VSS_36
H12	VSSIO_USB_18	VSS_37
H14	VSSIO_USB_19	VSS_38
H16	VSSIO_USB_20	VSS_39
H18	VSSIO_USB_21	VSS_40
J11	VSSIO_USB_22	VSS_41
J19	VSSIO_USB_23	VSS_42
K12	VSSIO_USB_24	VSS_43
K14	VSSIO_USB_25	VSS_44
K16	VSSIO_USB_26	VSS_45
K18	VSSIO_USB_27	VSS_46
H19	VSSIO_USB_28	VSS_47
Y4	EFUSE	VSS_48
D8	VSSAN_HWM	VSS_49
M19	VSSXL	VSS_50
P21	VSSIO_PCIECLK_1	VSS_PCIECLK_14
M20	VSSIO_PCIECLK_2	VSSIO_PCIECLK_15
M22	VSSIO_PCIECLK_3	VSSIO_PCIECLK_16
M24	VSSIO_PCIECLK_4	VSSIO_PCIECLK_17
P22	VSSIO_PCIECLK_5	VSSIO_PCIECLK_18
P24	VSSIO_PCIECLK_6	VSSIO_PCIECLK_19
P26	VSSIO_PCIECLK_7	VSSIO_PCIECLK_20
T20	VSSIO_PCIECLK_8	VSSIO_PCIECLK_21
T22	VSSIO_PCIECLK_9	VSSIO_PCIECLK_22
T24	VSSIO_PCIECLK_10	VSSIO_PCIECLK_23
V20	VSSIO_PCIECLK_11	VSSIO_PCIECLK_24
J23	VSSIO_PCIECLK_12	VSSIO_PCIECLK_25
J23	VSSIO_PCIECLK_13	VSSIO_PCIECLK_26
J23	VSSIO_PCIECLK_14	VSSIO_PCIECLK_27

Part 5 of 5

QUANTA COMPUTER

Title: **SB8X0 POWER(4/4)**

Size: Custom | Document Number: **AMD** | Rev: 3A

Date: Saturday, March 20, 2010 | Sheet: 13 of 34

1.Level 1 Environment-related Substances Should NEVER be Used.
 2.Purchase ink, paint, wire rods, and Molding resins only from the business Partners that Sony approves as Green Partners.

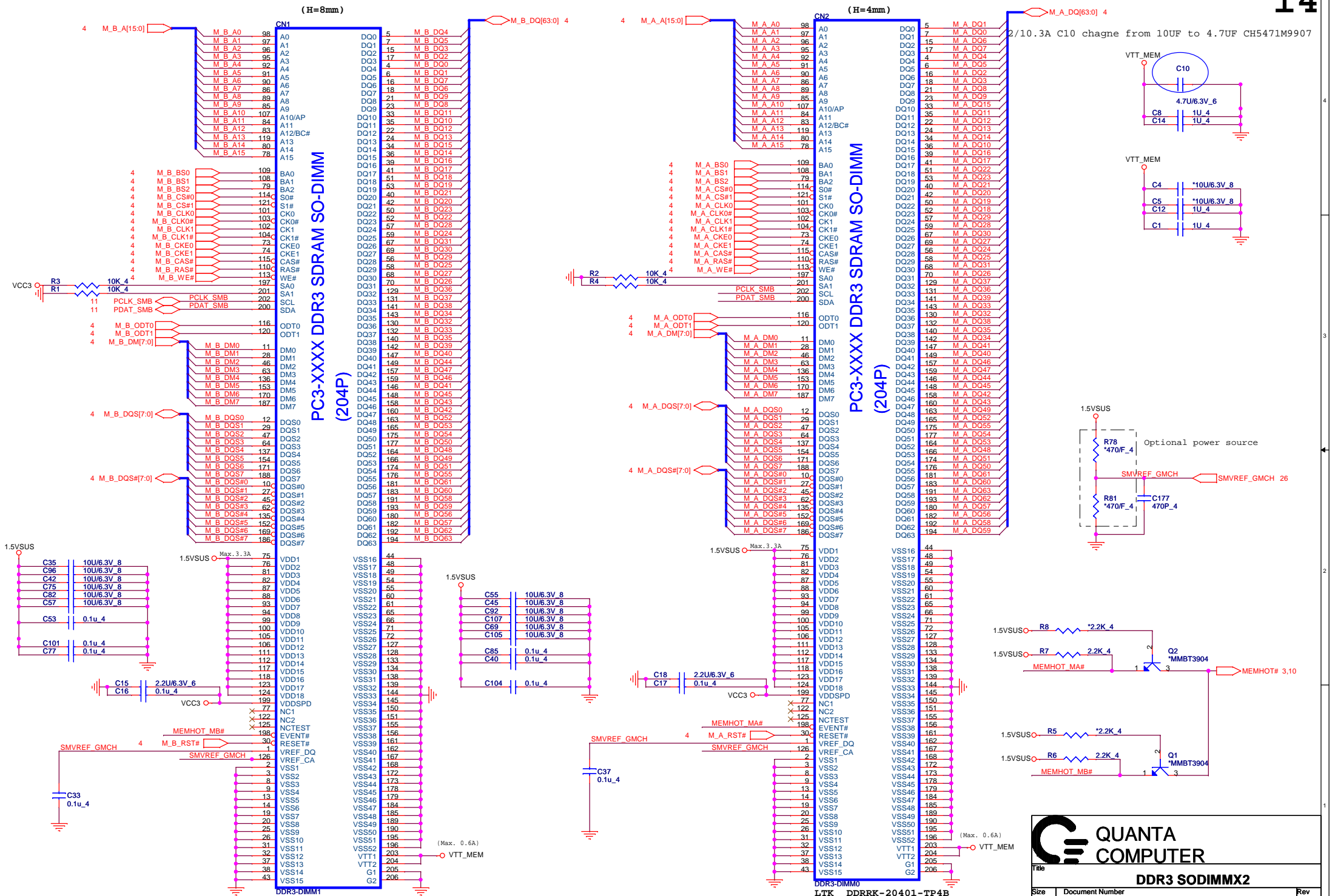

QUANTA COMPUTER

Title: **DDR3 SODIMMX2**

Size	Document Number	Rev
Custom	AMD	3A

Date: Saturday, March 20, 2010 Sheet 14 of 34

1.Level 1 Environment-related Substances Should NEVER be Used.
 2.Purchase Ink, paint, wire rods, and Molding resins only from the business Partners that Sony agrees as Green Partners.

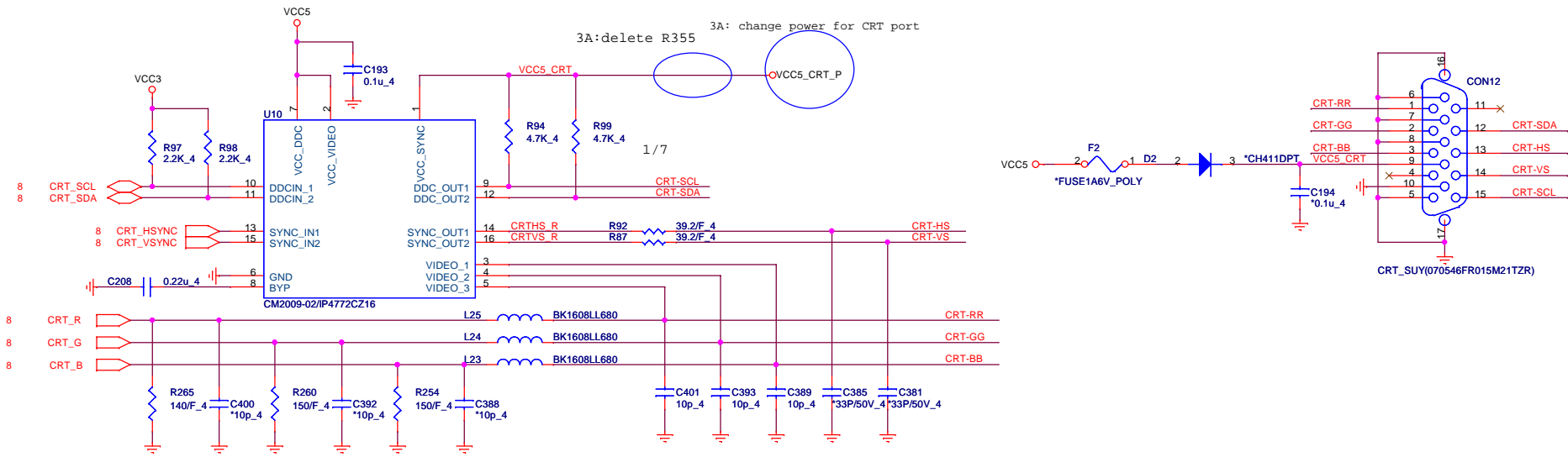

LVDS

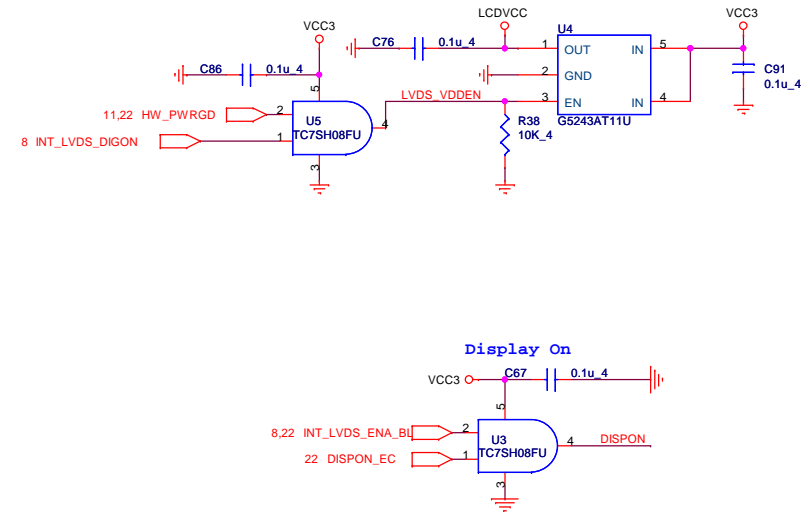
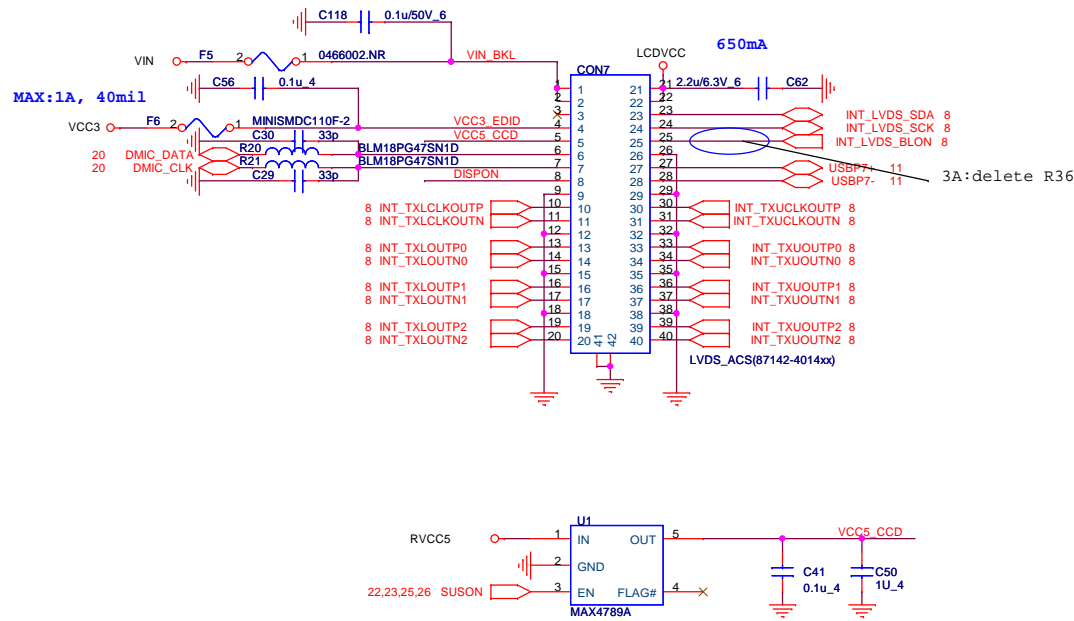

QUANTA COMPUTER

Title: **CRT/LVDS**

Size Custom	Document Number AMD	Rev 3A
Date: Saturday, March 20, 2010	Sheet 15 of 34	

1.Level 1 Environment-related Substances Should NEVER be Used.
 2.Purchase ink, paint, wire rods, and Molding resins only from the business Partners that Sony approves as Green Partners.

3A: change power source for CRT port

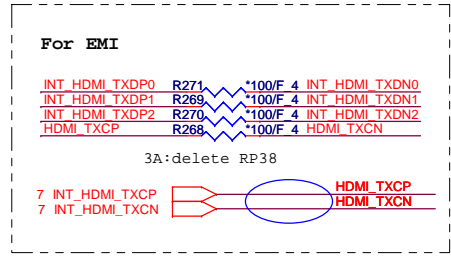
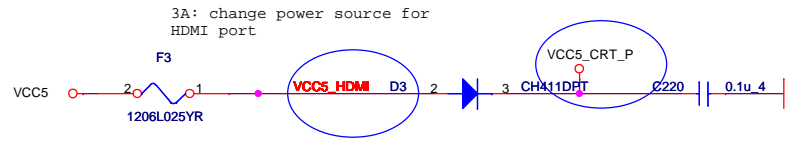

3A: VCC5 -> VCC3

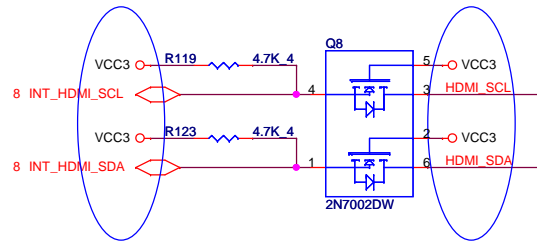

3A: Prevent incorrect voltage level

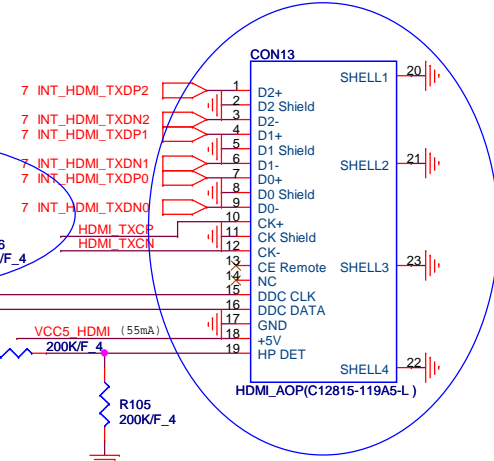
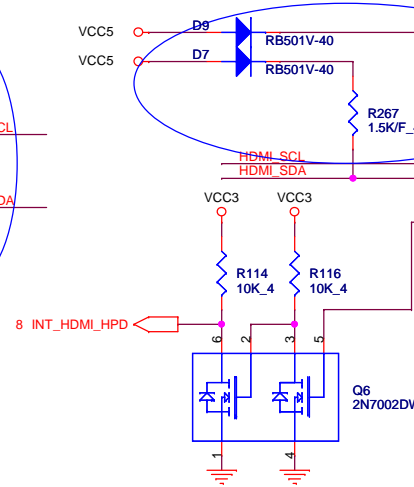

3A: Change CON13 footprint:
from hdmi-c12806-11908-1-19p-v to Hdmi-c12825-11908-1-19p-v

For ESD

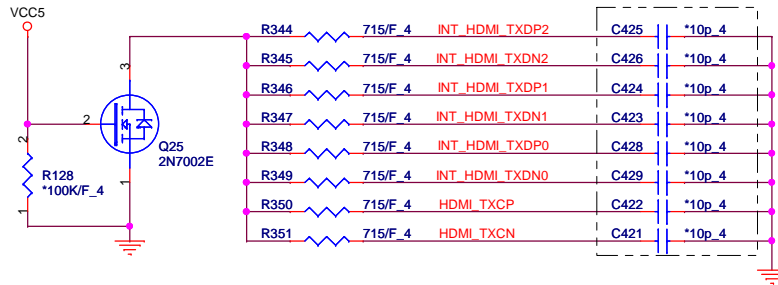

1.Level 1 Environment-related Substances Should NEVER be Used.
2.Purchase ink, paint, wire rods, and Molding resins only from the business Partners that Sony approves as Green Partners.

QUANTA COMPUTER

Title: **HDMI**

Size B	Document Number	Rev 3A
	AMD	

Date: Saturday, March 20, 2010 Sheet 16 of 34

WLAN

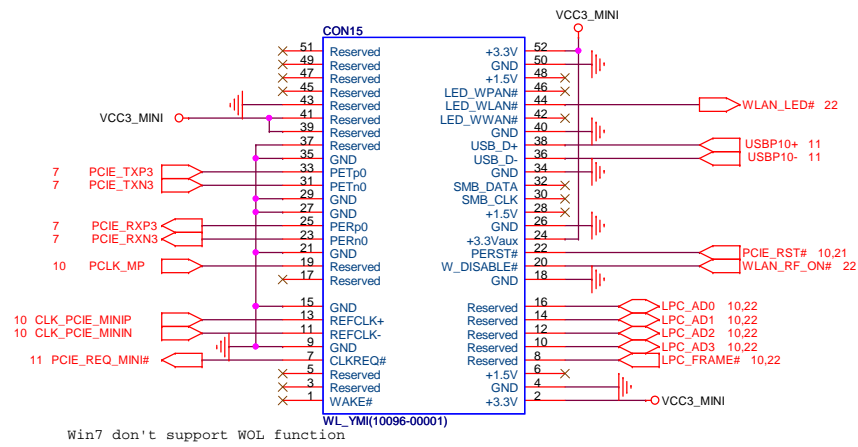

WLAN_BT_S/W

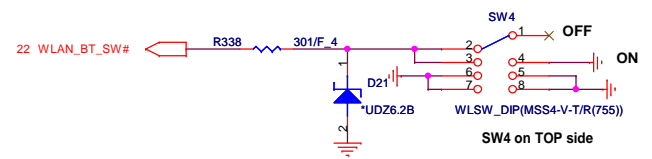
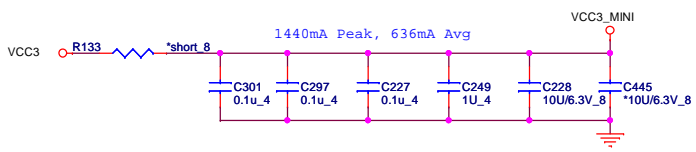

SATA ODD

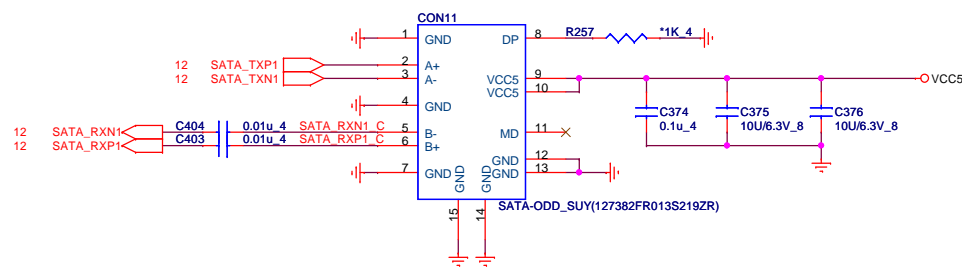

SATA HDD

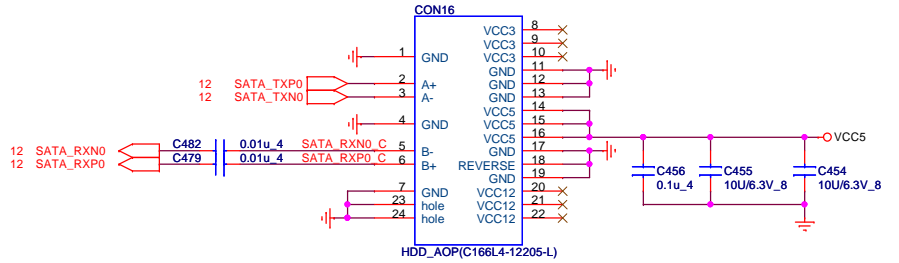

QUANTA COMPUTER

Title: **WLAN/HDD/ODD**

Size: Custom | Document Number: AMD | Rev: 3A

Date: Saturday, March 20, 2010 | Sheet: 17 of 34

1. Level 1 Environment-related Substances should NEVER be used.
2. Purchase ink, paint, wire rods, and Molding resins only from the business Partners that Sony approves as Green Partners.

3A:Change MR19,MR3,MR2,MR9,MR10,MR11,MR12,MR13,MR14,MR15,MR16,MR17,MR18,MR8 to short pad

3A change ML1 to short pad

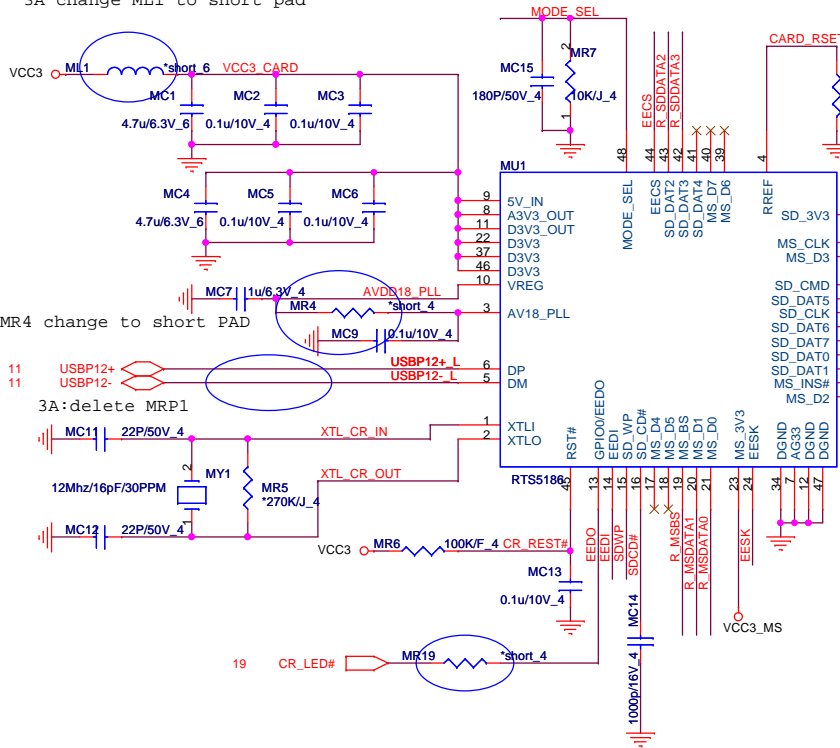

3A:MR4 change to short PAD

3A:delete MRP1

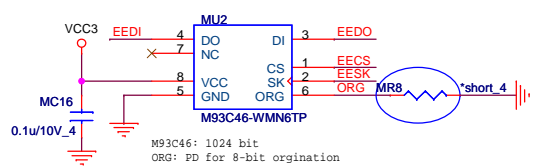
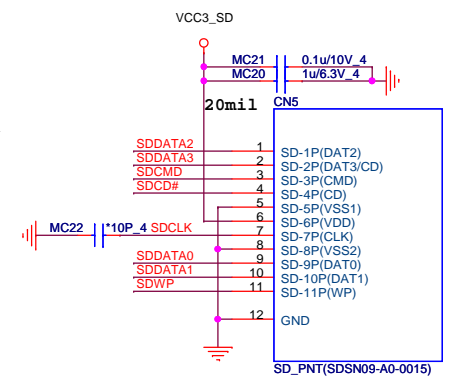
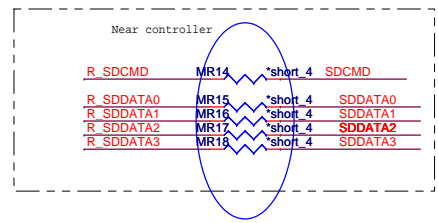
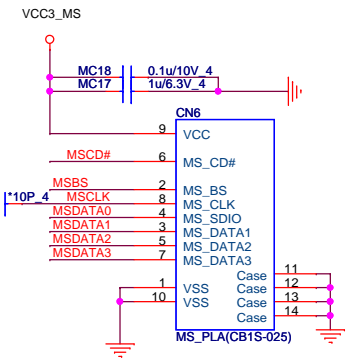
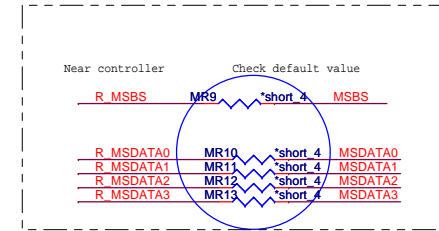

1.Level 1 Environment-related Substances Should NEVER be Used.
 2.Purchase ink, paint, wire rods, and Molding resins only from the business Partners that Sony approves as Green Partners.

QUANTA COMPUTER

Title: **CARD READER(RTS5186)**

Size: Custom Document Number: **AMD** Rev: 3A

Date: Saturday, March 20, 2010 Sheet: 18 of 34

Bluetooth

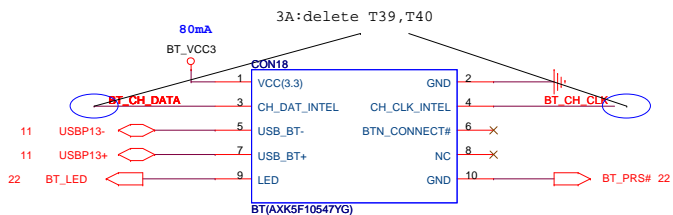
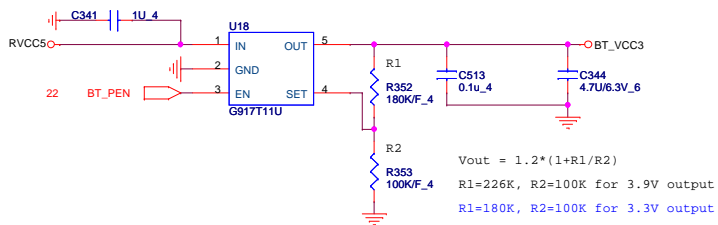

Two Color :
 everlight : 19-22UYOSYGC (BEAG0028ZA0_
 liteon : LTST-C195KGFKT (BEAG0032ZA0)
 Amber :
 everlight : 19-21UYOC/S530-A6/TR8 (BEAB0015Z06)
 liteon : LTST-C190KFKT (BEAB0006Z07)
 Green :
 everlight : 19-21SYGC/S530-E2/TR8 (BEYG0053ZA2)
 liteon : LTST-C190KFKT (BEGR0080Z07)
 Yellow :
 everlight : 19-21UYC/S530-A2/TR8 (BEYL0016Z08)
 liteon : LTST-C190KSKT (BEYL0024Z01)

Battery LED

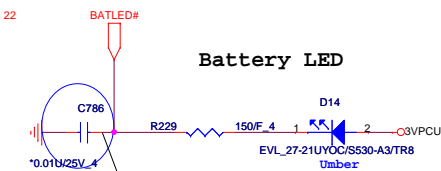

RF LED

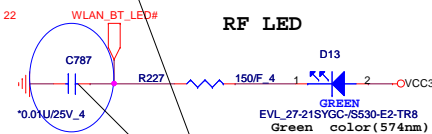

3A : Reverse C786, C787, C788 FP for ESD

CR LED

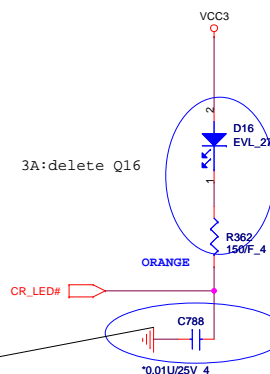

HDD LED

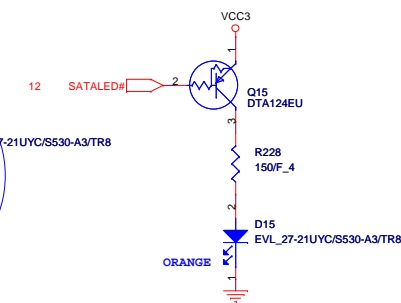

Title			Express Card/LED/BT	
Size	Document Number	AMD		Rev
Custom				3A
Date:	Saturday, March 20, 2010	Sheet	19	of 34

1.Level 1 Environment-related Substances Should NEVER be Used.
 2.Purchase ink, paint, wire rods, and Molding resins only from the business Partners that Sony approves as Green Partners.

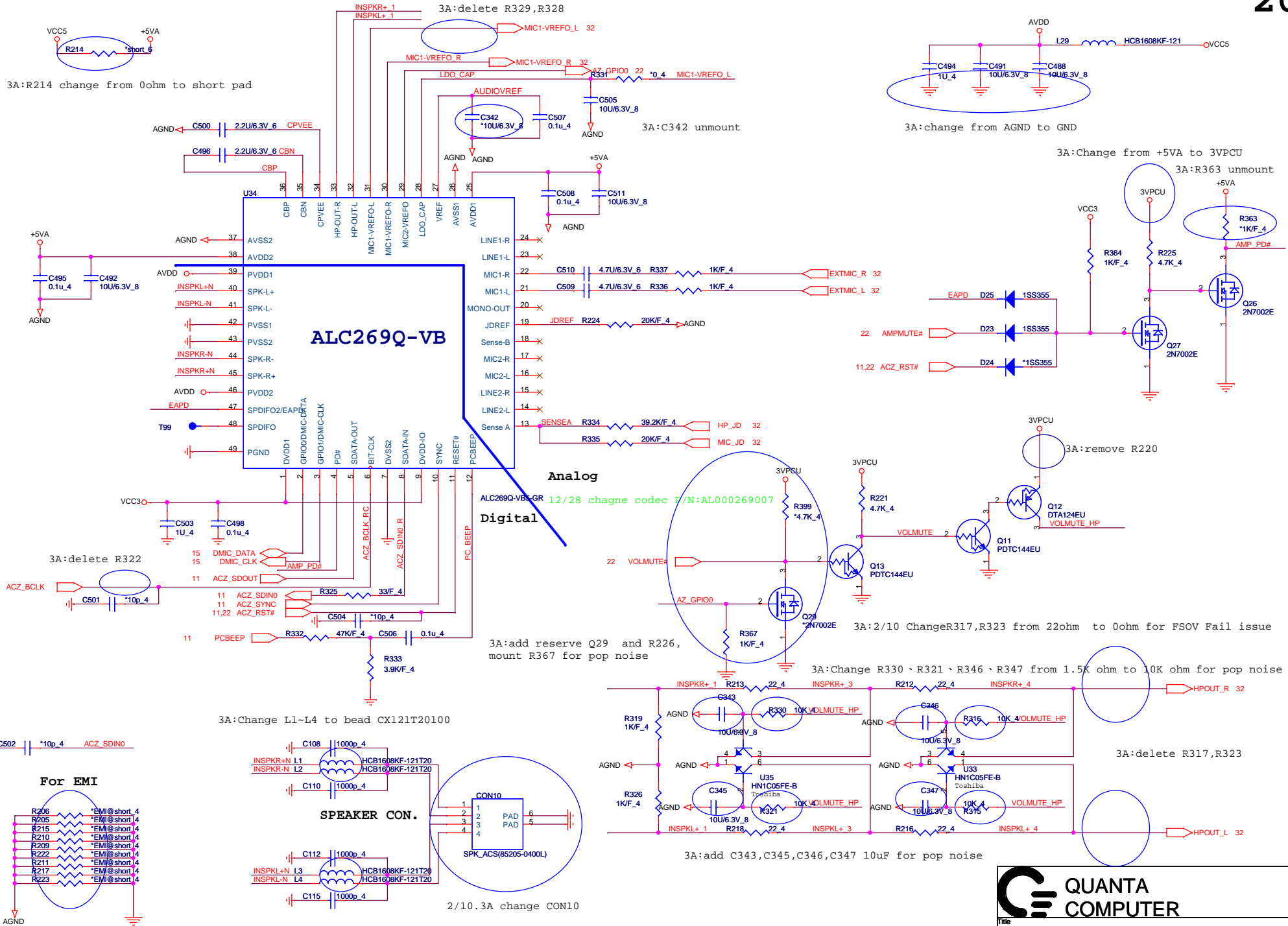

QUANTA COMPUTER

Title: **Codec ALC269Q**

Size	Document Number	Rev
Custom	AMD	3A

Date: Saturday, March 20, 2010 Sheet 20 of 34

1.Level 1 Environment-related Substances Should NEVER be Used.
 2.Purchase ink, paint, wire rods, and Molding resins only from the business Partners that Sony approves as Green Partners.

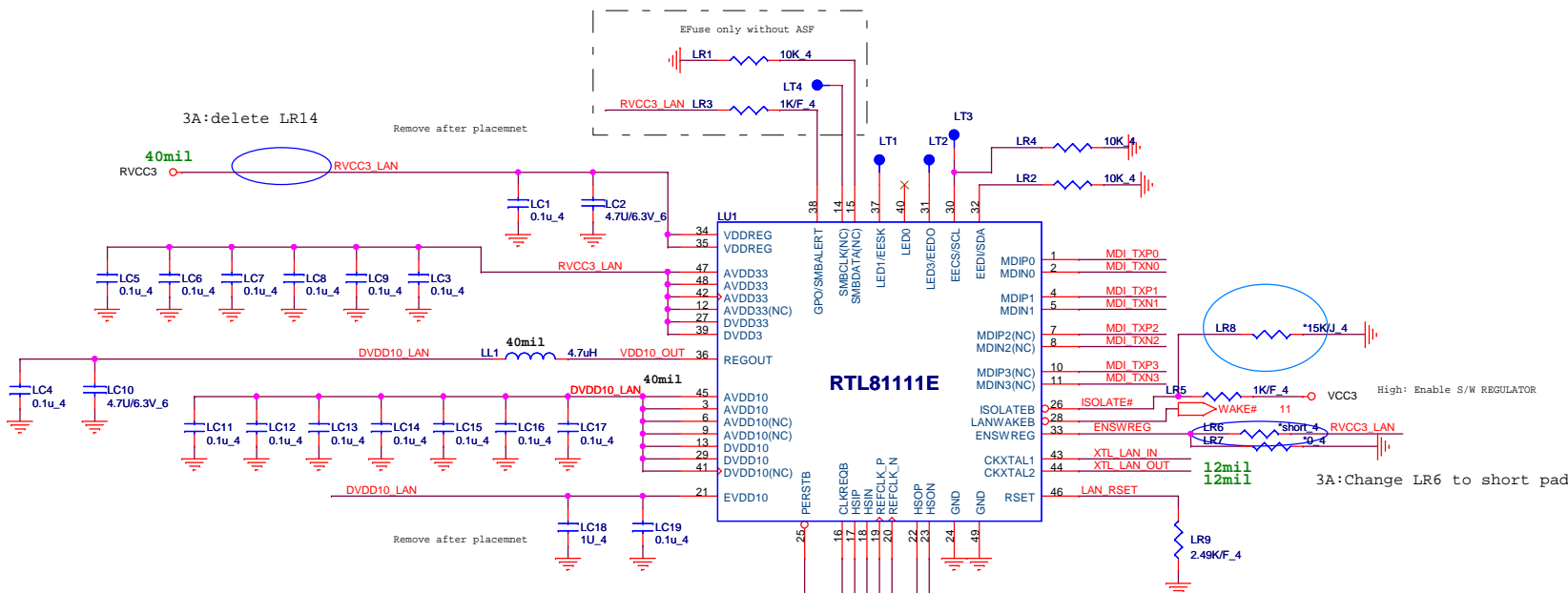

LU2: 2nd DBBL5MLAN01 (LFE9276A-R) DTA
 DB0Z06LAN00 (GST5009B LF) BOT
 DB0LL1LAN00 (NS892407) FCE

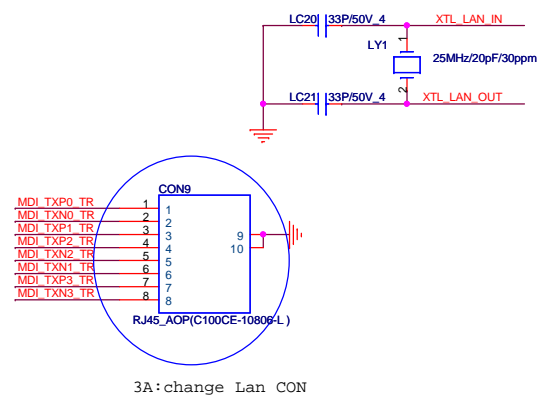
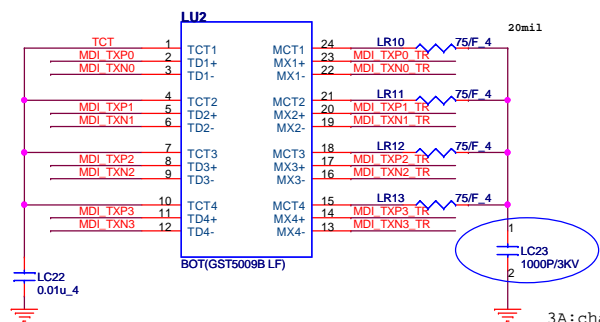

3A:change LC23 for hi port issue

1. Level 1 Environment-related Substances Should NEVER be Used.
 2. Purchase ink, paint, wire rods, and Molding resins only from the business Partners that Sony approves as Green Partners.

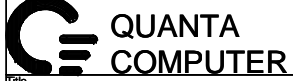

**QUANTA
COMPUTER**

Title: **LAN RTL8111E**

Size: Custom	Document Number: AMD	Rev: 3A
Date: Saturday, March 20, 2010		Sheet: 21 of 34

I/O Address		
BADDR1-0	Index	Data
* 1 0	2E	2F
1 1	4E	4F
0 0	{HCFGBAH, HCFGBAL} {HCFGBAH, HCFGBAL}+1	
0 1	XOR-TREE TEST	

SHMB: SHMB(If = 0 Enable share host BIOS memory)

DOCK_RST# : BADDR0
T7: BADDR1

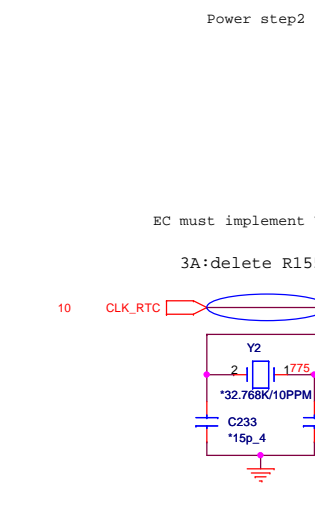
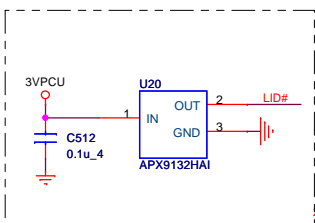
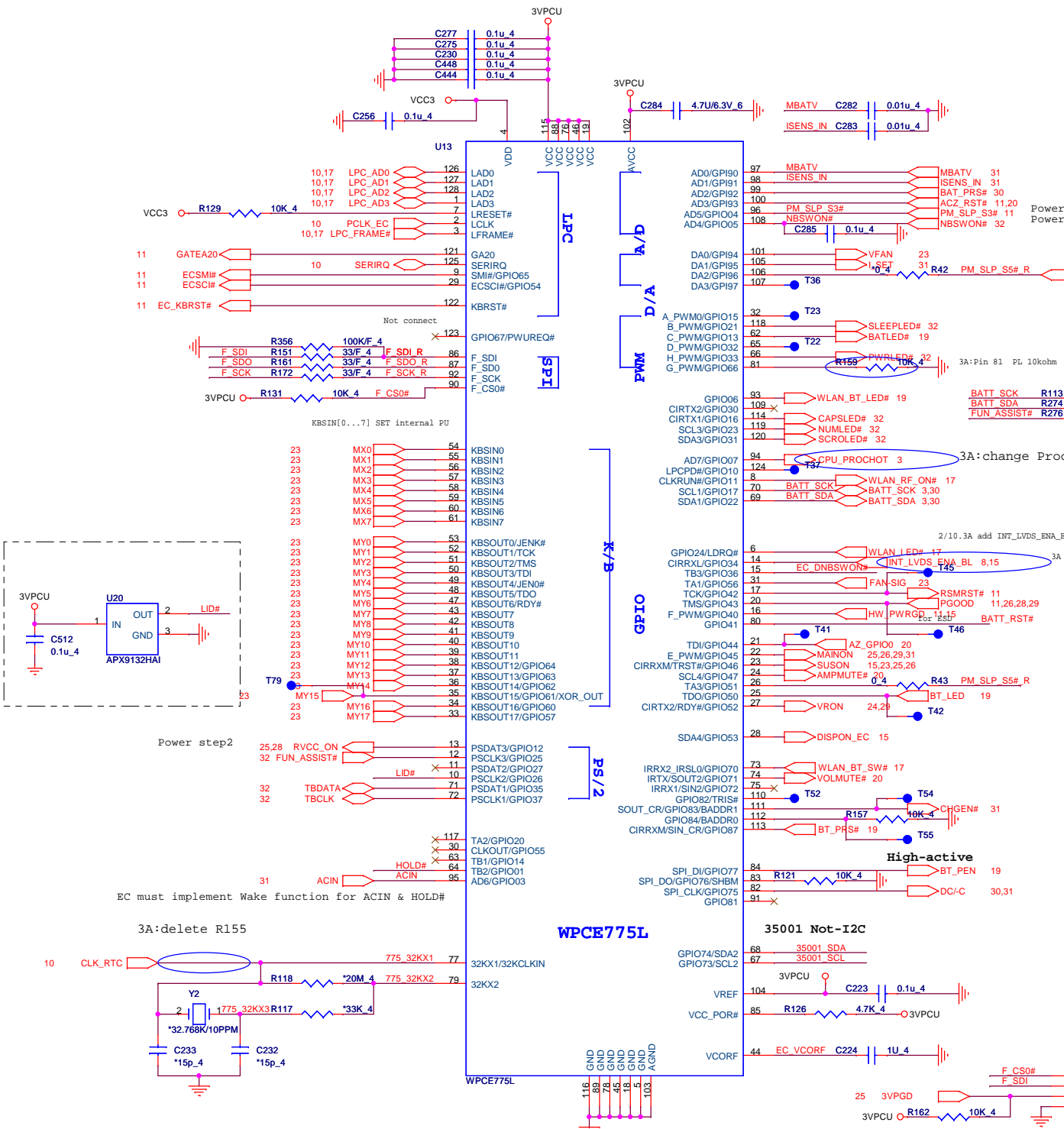
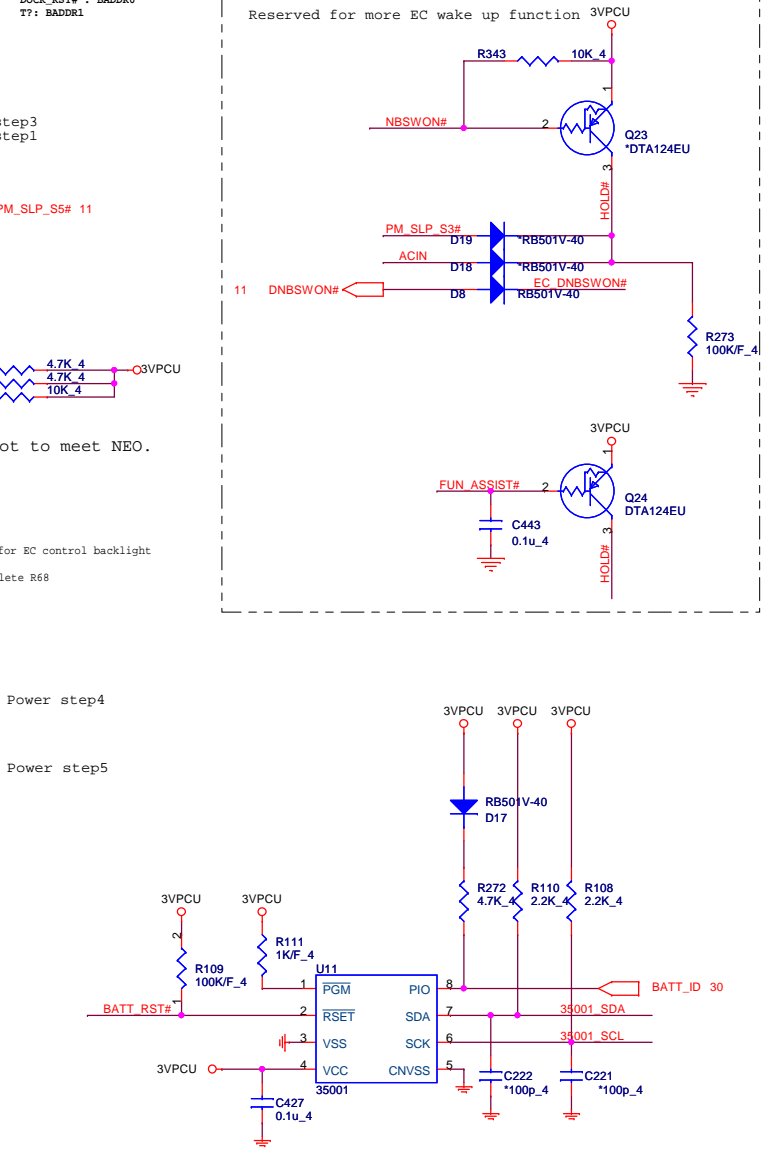
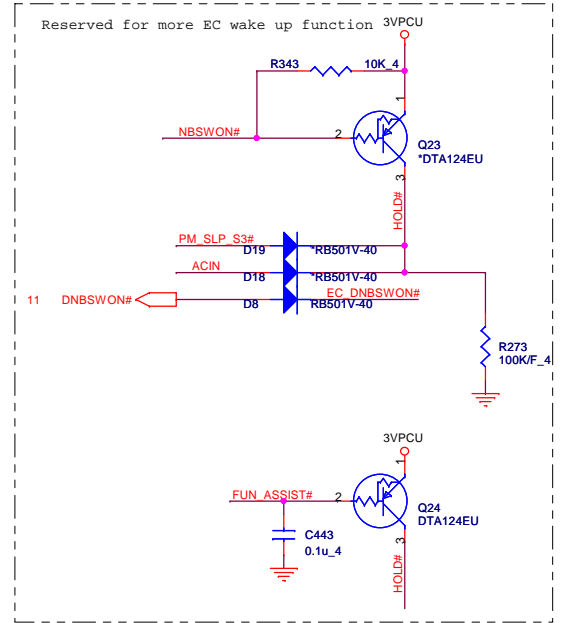

1. Level 1 Environment-related Substances Should NEVER be used.
 2. Purchase ink, paint, wire rods, and Molding resins only from the business Partners that Sony approves as Green Partners.

QUANTA COMPUTER

Title: **WPC8775L & FLASH**

Size: Custom Document Number: AMD Rev: 3A

Date: Saturday, March 20, 2010 Sheet: 22 of 34

KEYBOARD

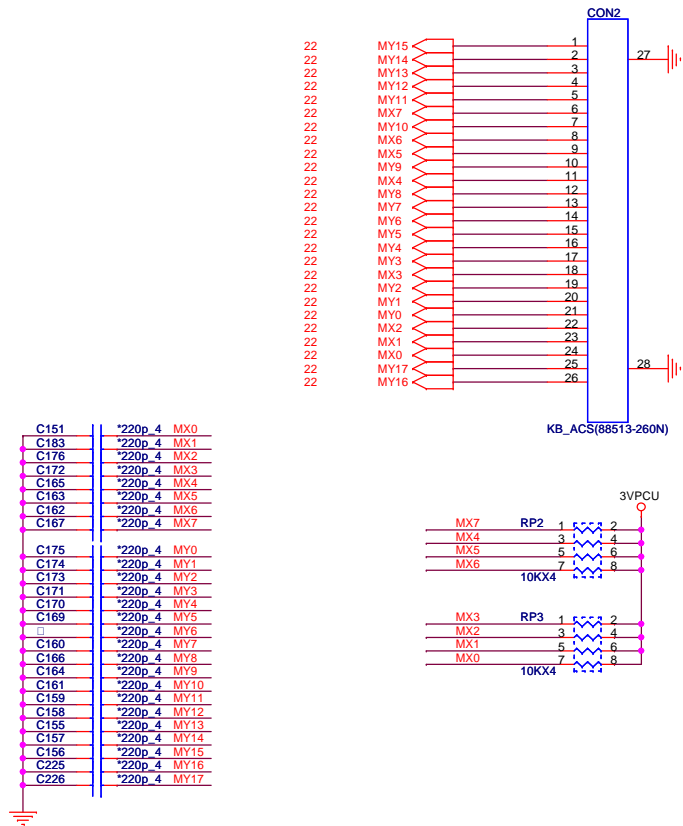

FAN

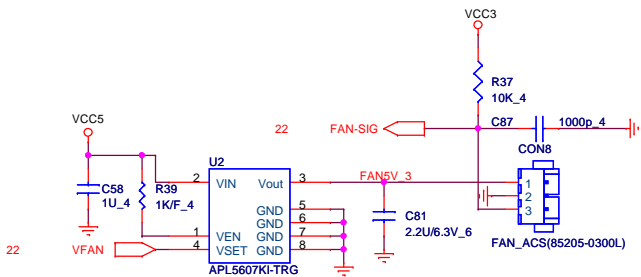

USB Port

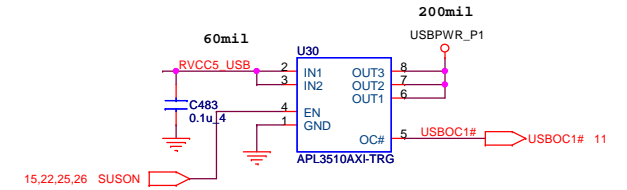
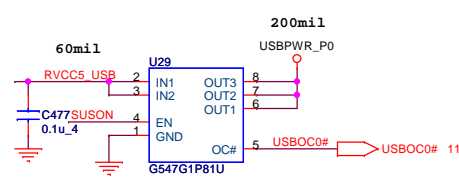
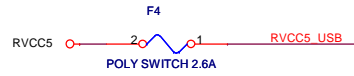

USB Port on MB

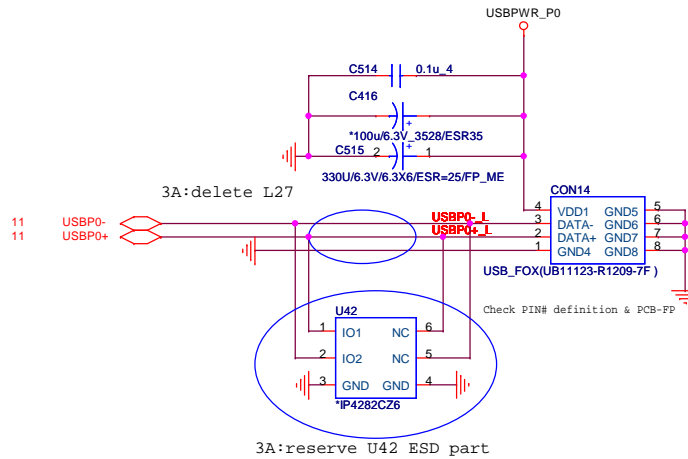

QUANTA COMPUTER

Title: **KB/USB/FAN/PS**

Size: Custom	Document Number: AMD	Rev: 3A
Date: Saturday, March 20, 2010	Sheet: 23 of 34	

1. Level 1 Environment-related Substances Should NEVER be Used.
2. Purchase ink, paint, wire rods, and Molding resins only from the business Partners that Sony approves as Green Partners.

ISL6265 Pin1	OFS	VFIXEN
1.2V	V	X
3.3V	X	V
5V	X	X

VFIXEN VID Codes

SVC	SVD	Output
0	0	1.4
0	1	1.2
1	0	1.0
1	1	0.8

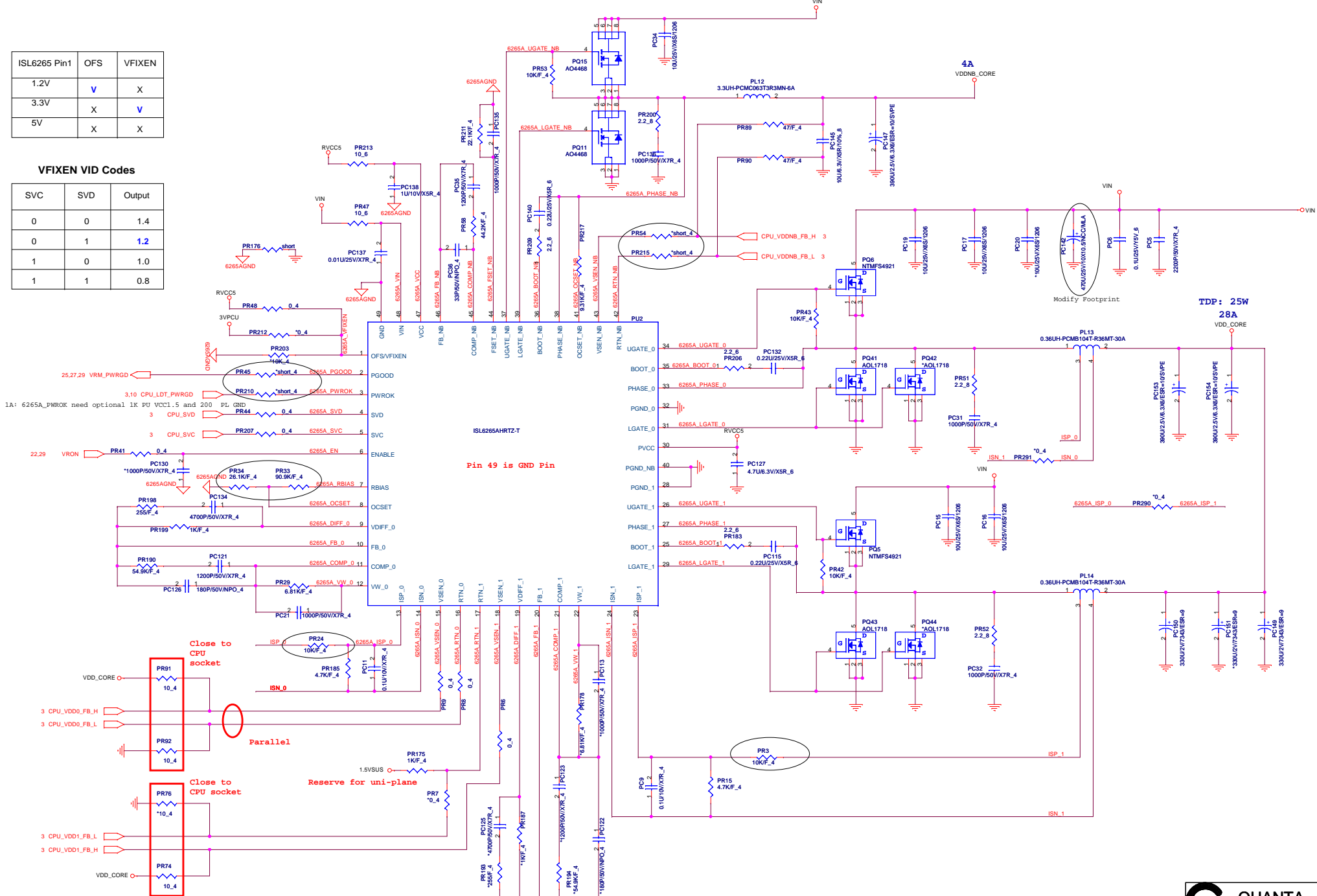

TDP: 25W
28A
VDD_CORE

QUANTA COMPUTER
VCORE(ISL6265A)
 Date: Saturday, March 20, 2010 Sheet 24 of 8

1.Level 1 Environment-related Substances Should NEVER be Used.
 2.Purchase ink, paint, wire rods, and Molding resins only from the business Partners that Sony approves as Green Partners.

3.3V & 5V

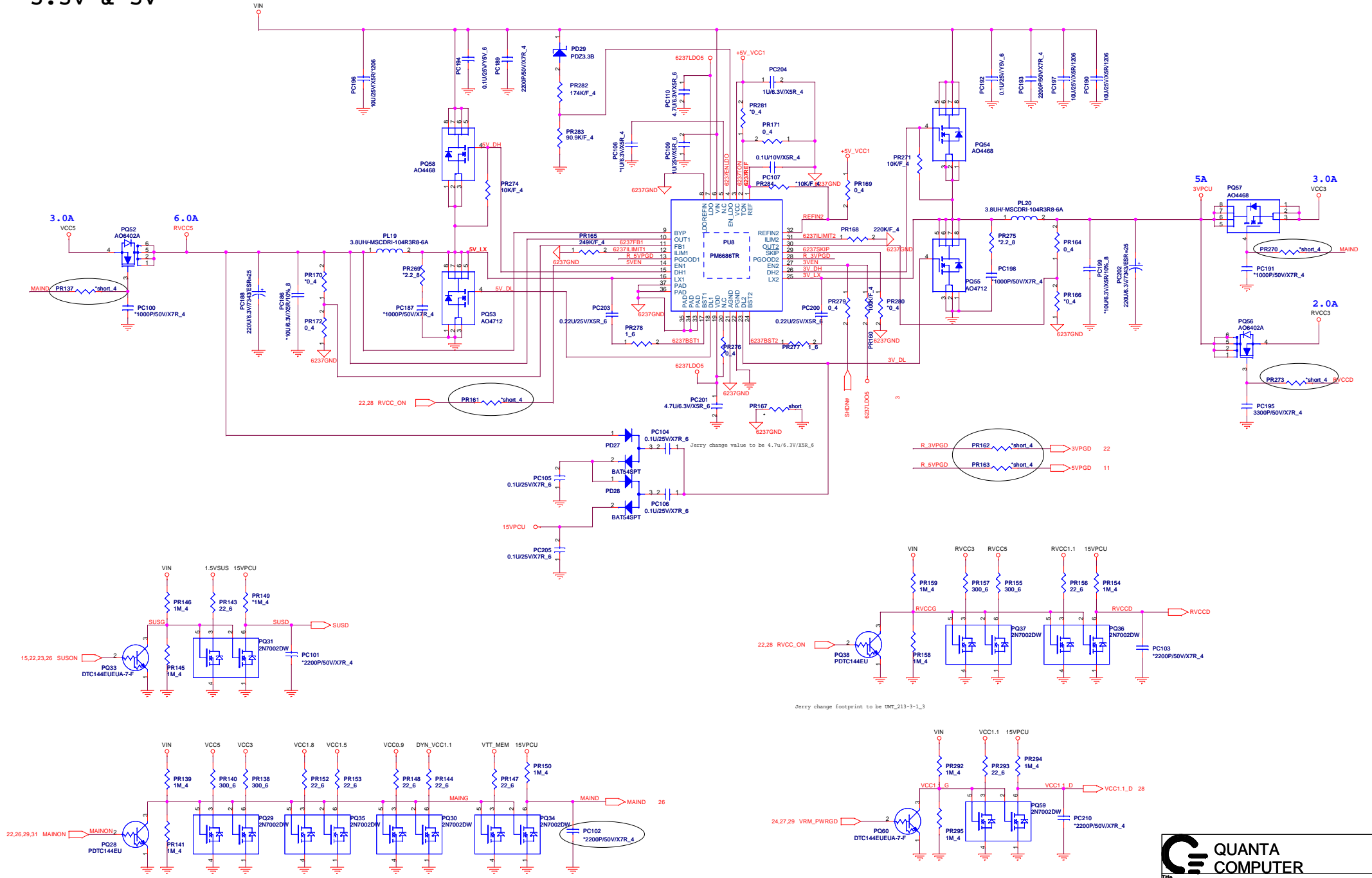

1.Level 1 Environment-related Substances should NEVER be Used.
 2.Purchase ink, paint, wire rods, and Soldering resins only from the Business Partners that Sony approves as Green Partners.

QUANTA COMPUTER

File: **3VPCU&5VPCU(PM6686)**

Size: Custom Document Number: **AMD** Row: 3A

Date: Saturday, March 20, 2010 Sheet: 25 of 8

1.5VSUS & VTT_MEM

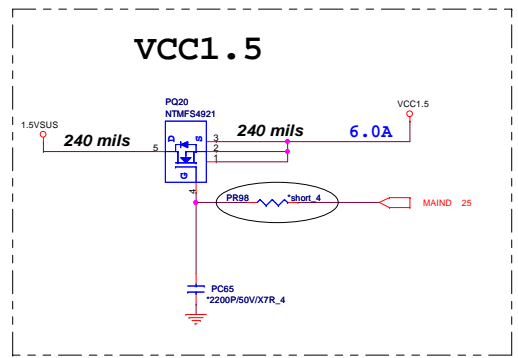
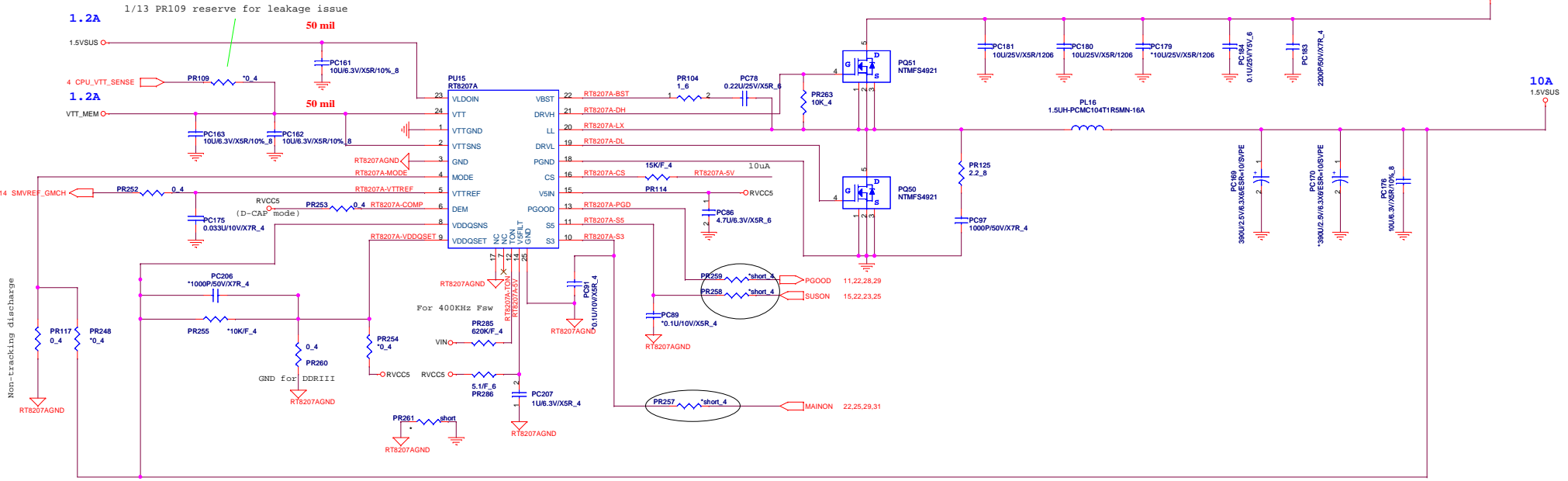

MODE	DISCHARGE MODE
+5V	No discharge
+1.8V	Tracking discharge
GND	Non-tracking discharge

VDDQSET	VDDQ(V)	VITREF & VIT	NOTE
GND	1.5 fixed	VDDQNS/2	DDR3
5V	1.8 fixed	VDDQNS/2	DDR2
FB-Resistor	Adjustable	VDDQNS/2	1.5V<VDDQ<3V

VIT = VITREF = VDDQNS/2 = 0.75V

STATE	S3	S5	1.5VSUS	VITREF	VIT
S0	1	1	on	on	on
S3	0	1	on	on	off
S4/S5	0	0	off	off	off

**QUANTA
COMPUTER**

File: **1.5VSUS/VTT_MEM**

Size: Custom Document Number: AMD Row: 3A

Date: Saturday, March 20, 2010 Sheet: 26 of 8

1. Level 1 Environment-related Substances Should NEVER be Used.
 2. Purchase ink, paint, wire rods, and Molding resins only from the business Partners that Sony approves as Green Partners.

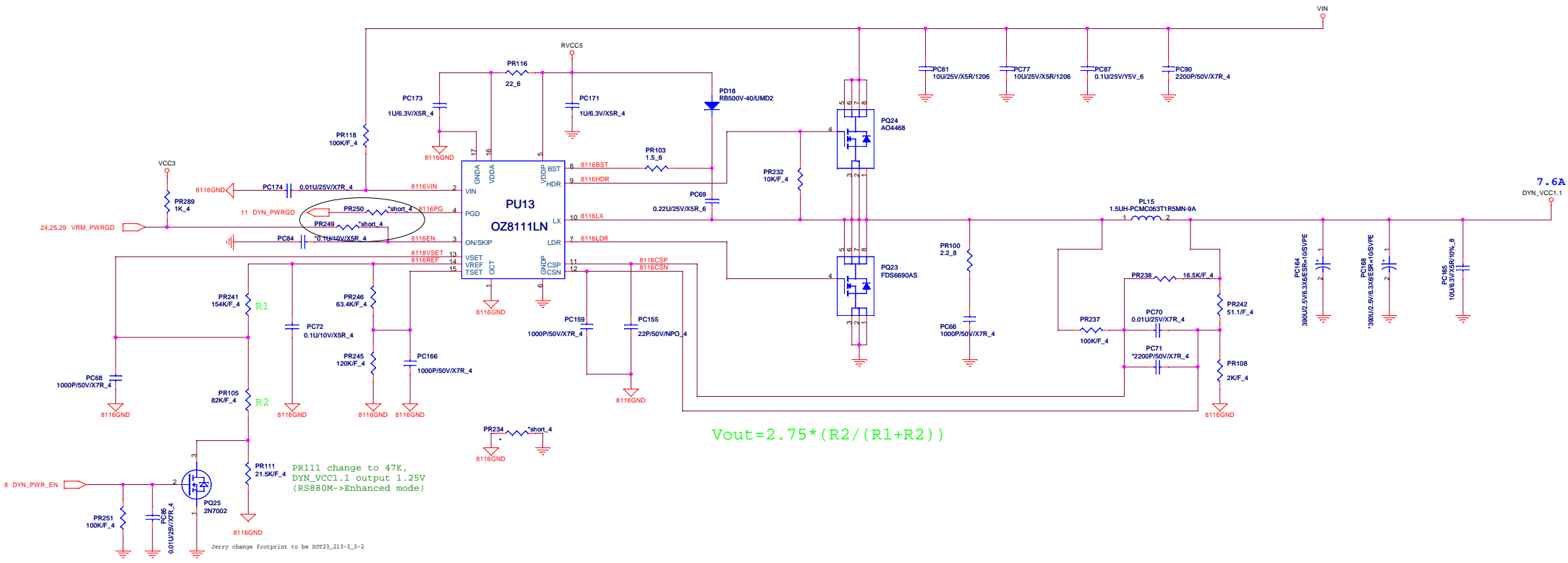

DYN_PWR_EN	High	Low
DYN_VCC1.1	0.95V	1.1V

QUANTA COMPUTER

Title: **DYN_VCC1.1(OZ8116LN)**

Size: Custom Document Number: AMD

Date: Saturday, March 20, 2010 Sheet: 27 of 8

Rev: 3A

1. Level 1 Environment-related Substances Should NEVER be Used.
2. Purchase ink, paint, wire rods, and Molding resins only from the business Partners that Sony approves as Green Partners.

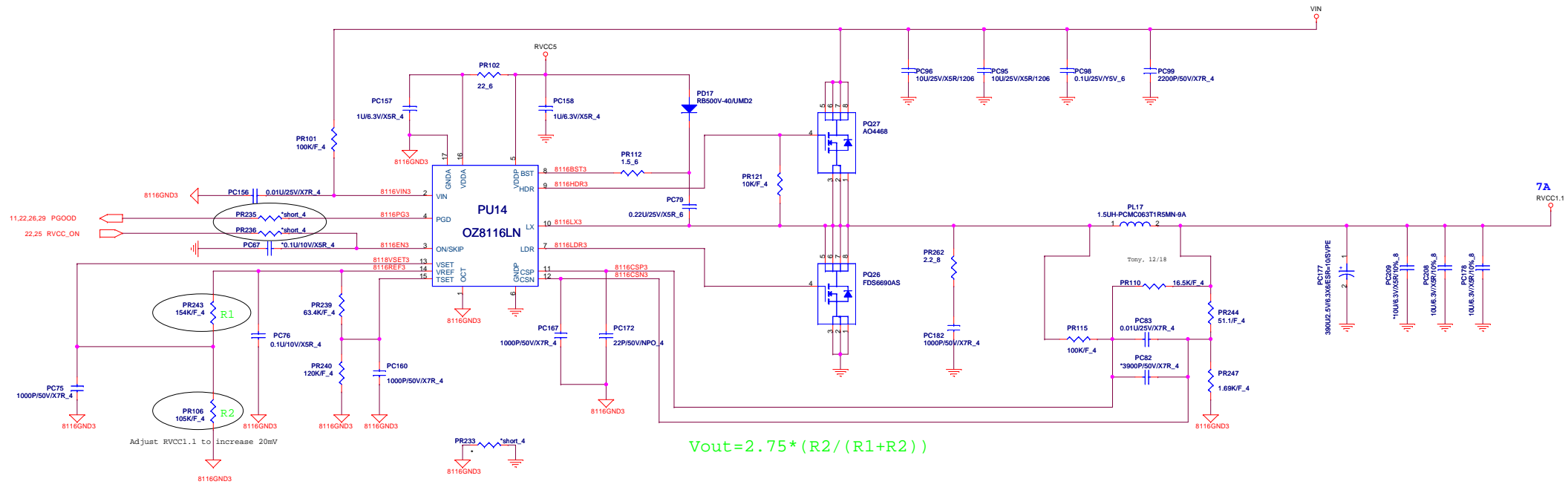

$V_{out} = 2.75 * (R2 / (R1 + R2))$

Adjust RVCC1.1 to increase 20mV

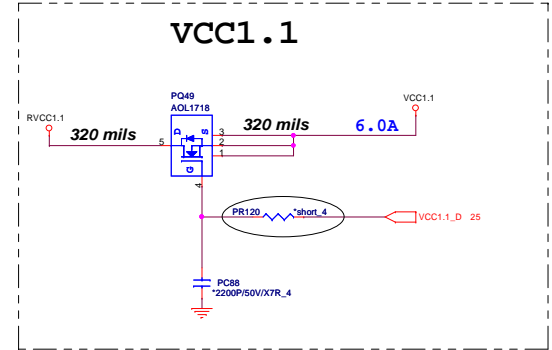

		QUANTA COMPUTER	
		Title: VCC1.1(OZ8116LN)-7A	
Size: Custom	Document Number: AMD	Rev: 3A	
Date: Saturday, March 20, 2010	Sheet: 28		of: 8

1. Level 1 Environment-related Substances Should NEVER be Used.
 2. Purchase ink, paint, wire rods, and Molding resins only from the business Partners that Sony approves as Green Partners.

VCC1.8

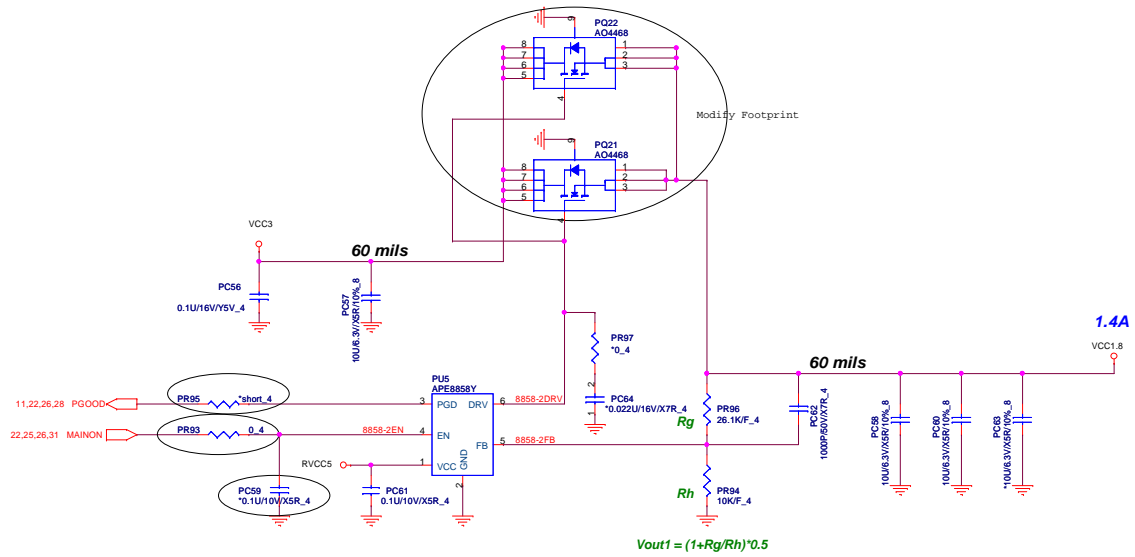

VCC0.9

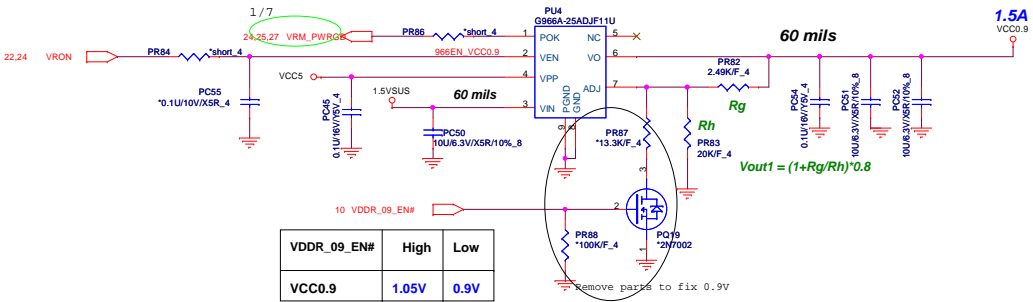

VDDR_09_EN#	High	Low
VCC0.9	1.05V	0.9V

VCC2.5

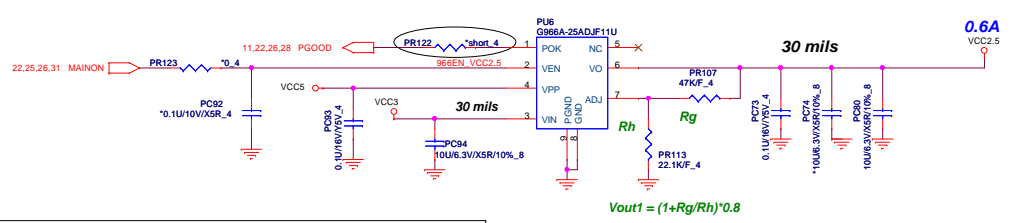

Thermal Protection for VEDS

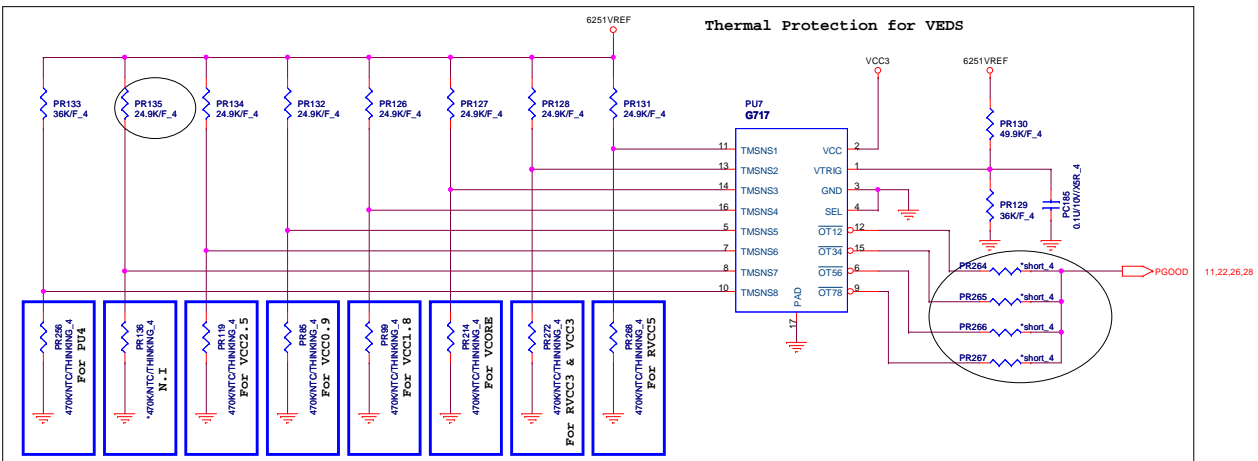

QUANTA COMPUTER

File: **VCC1.8/0.9/2.5**

Size: Custom Document Number: **AMD** Row: 3A

Date: Saturday, March 20, 2010 Sheet: 29 of 8

1. Level 1 Environment-related Substances should NEVER be used.
 2. Purchase ink, paint, wire rods, and Molding resins only from the business Partners that Sony approves as Green Partners.

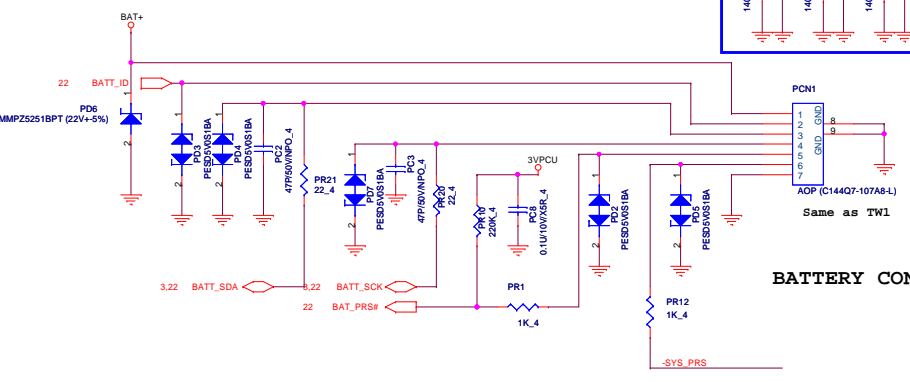
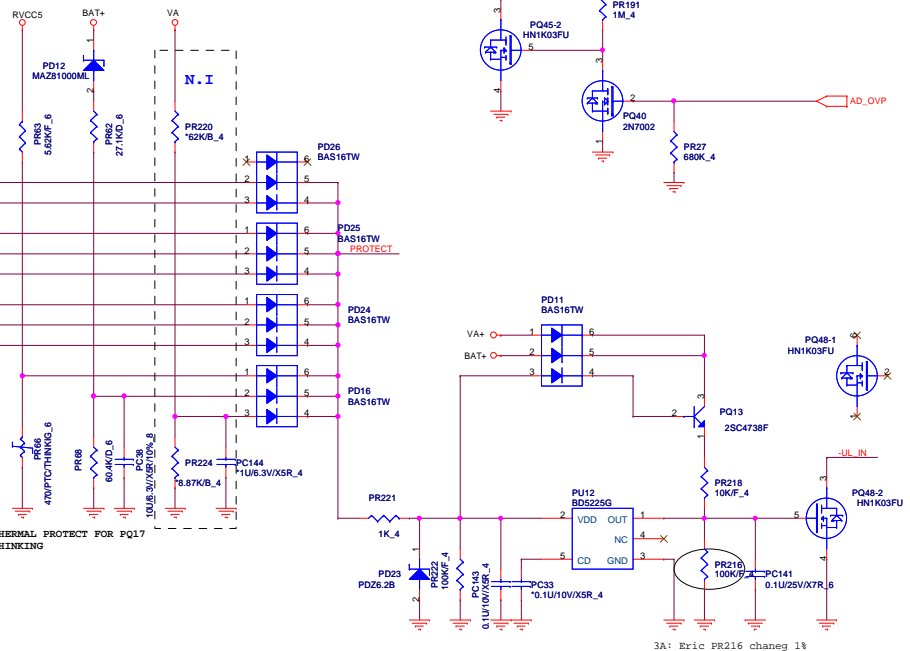
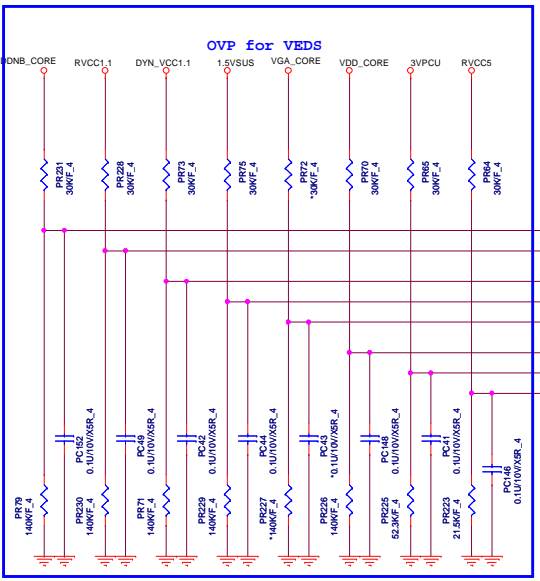
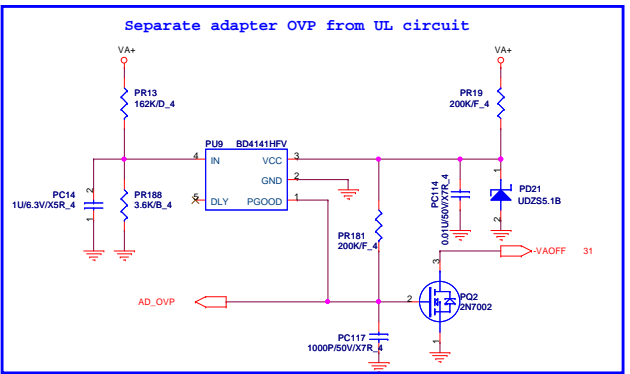
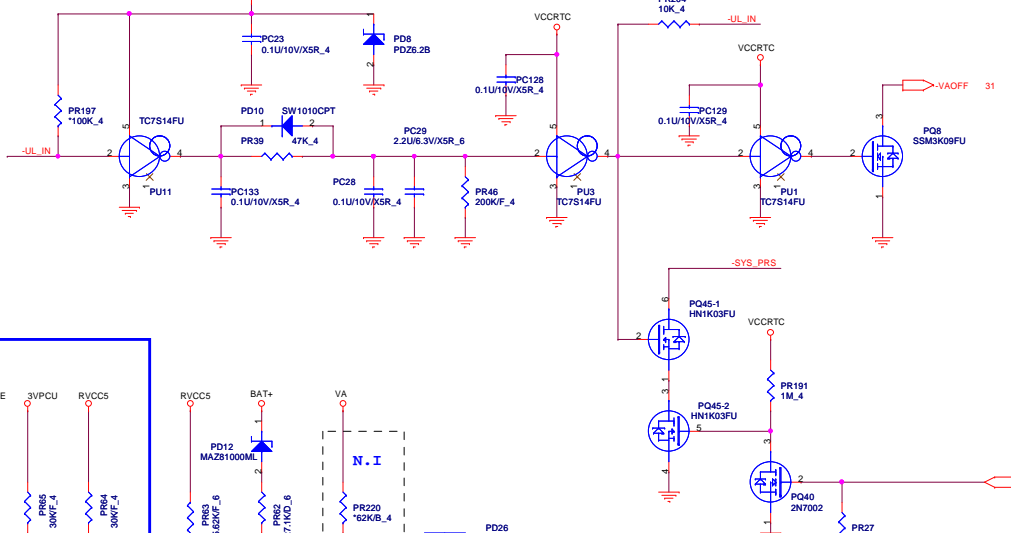
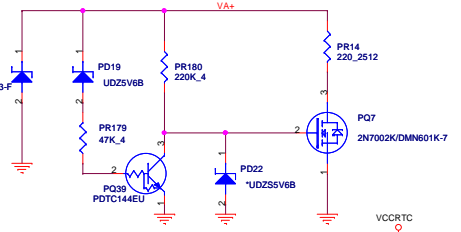
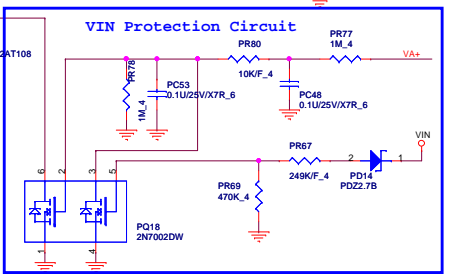
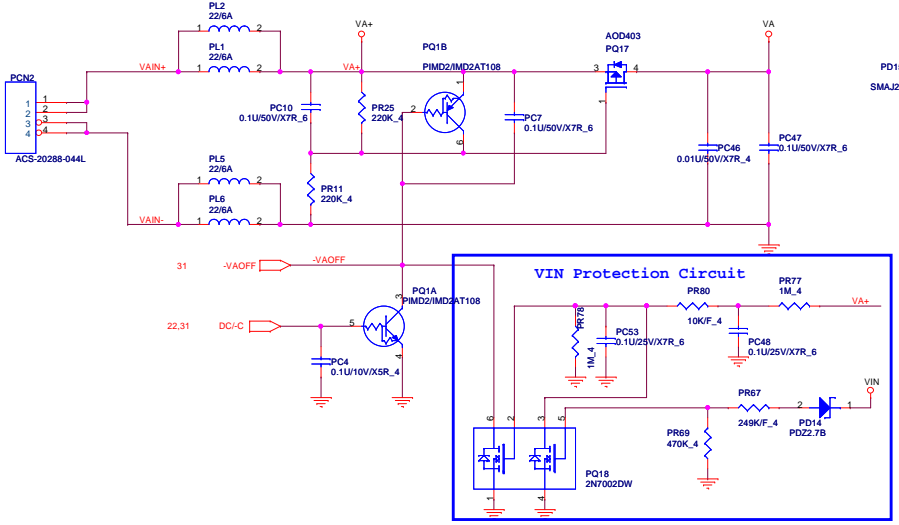

QUANTA COMPUTER
BAT IN/ADA IN/UL
 File: _____
 Size: Custom Document Number: AMD
 Date: Saturday, March 20, 2010 Sheet 30 of 8

1. Level 1 Environment-related Substances Should NEVER be Used.
 2. Purchase ink, paint, wire rods, and Molding resins only from the business Partners that Sony approves as Green Partners.

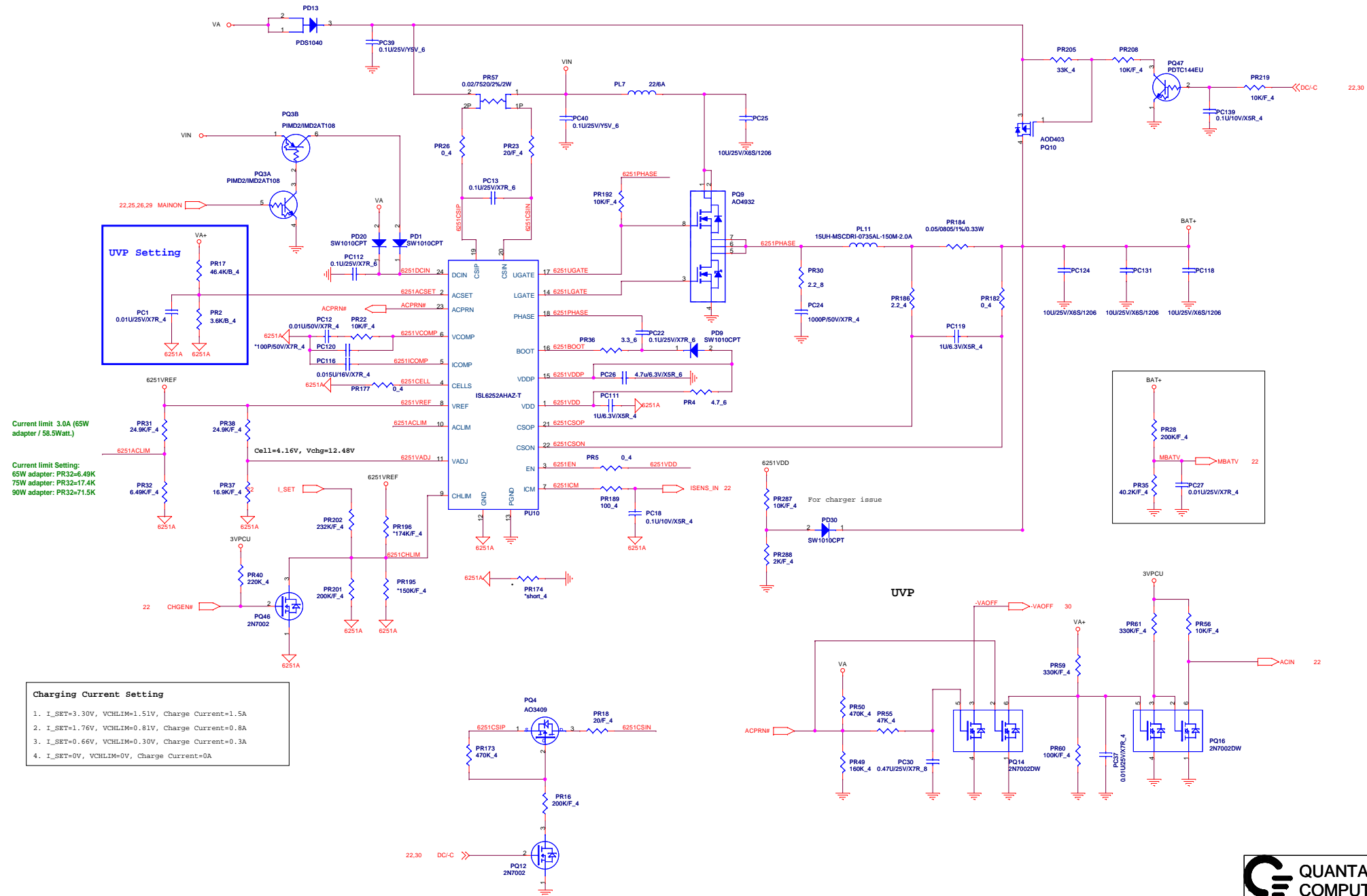

UVP Setting

VA+
PR17 46.4K/4
PR2 3.6K/4
PC1 0.01U/25V/X7R_4
PC2 3.6K/4

Current limit 3.0A (65W adapter / 58.5Watt.)

Current limit Setting:
65W adapter: PR32=6.49K
75W adapter: PR32=17.4K
90W adapter: PR32=71.5K

Charging Current Setting

1. I_SET=3.30V, VCHLIM=1.51V, Charge Current=1.5A
2. I_SET=1.76V, VCHLIM=0.81V, Charge Current=0.8A
3. I_SET=0.66V, VCHLIM=0.30V, Charge Current=0.3A
4. I_SET=0V, VCHLIM=0V, Charge Current=0A

BAT+
PR28 200K/4
MBATV
PR35 40.2K/4
PC27 0.01U/25V/X7R_4

QUANTA COMPUTER

CHARGER(ISL6252A)

Document Number: AMD
Date: Saturday, March 20, 2010

Sheet 31 of 8

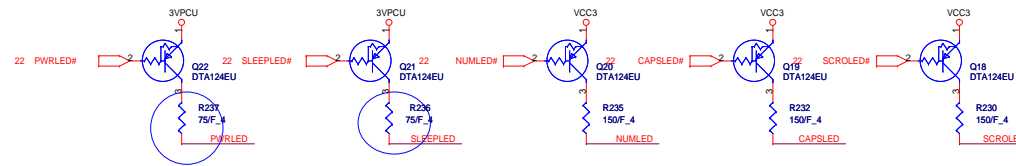

3A: change R236,R237 from 150 ohm to 75ohm for two color LED

MB to LED board

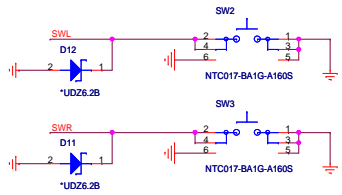
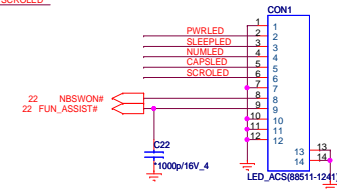

MB to TP connector

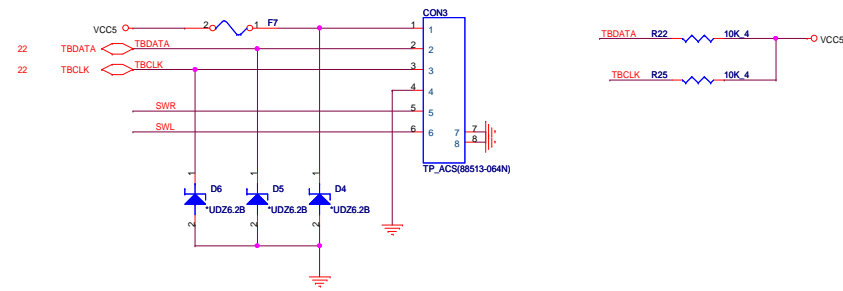

MB to USB board

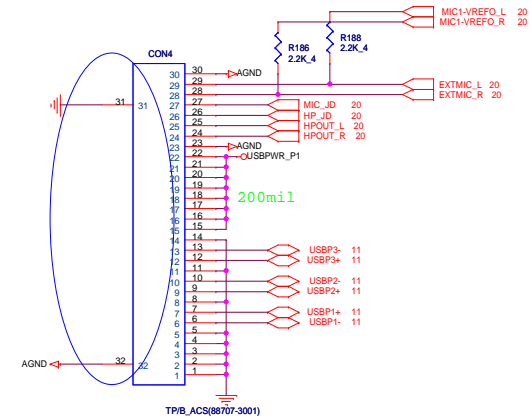

3A change from 88511-3001 to 88707-3001

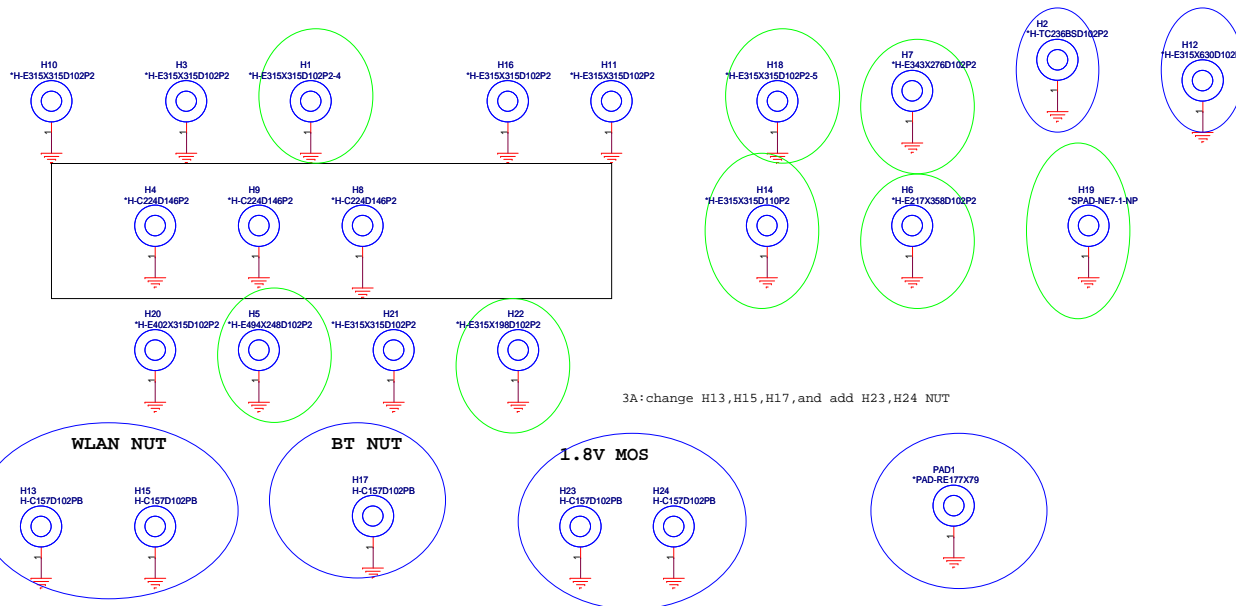

3A:change H13,H15,H17,and add H23,H24 NUT

QUANTA COMPUTER

Title: **Small board**

Size C	Document Number: AMD	Rev: 3A
Date: Saturday, March 20, 2010	Sheet: 32 of 34	

Decoupling Cap

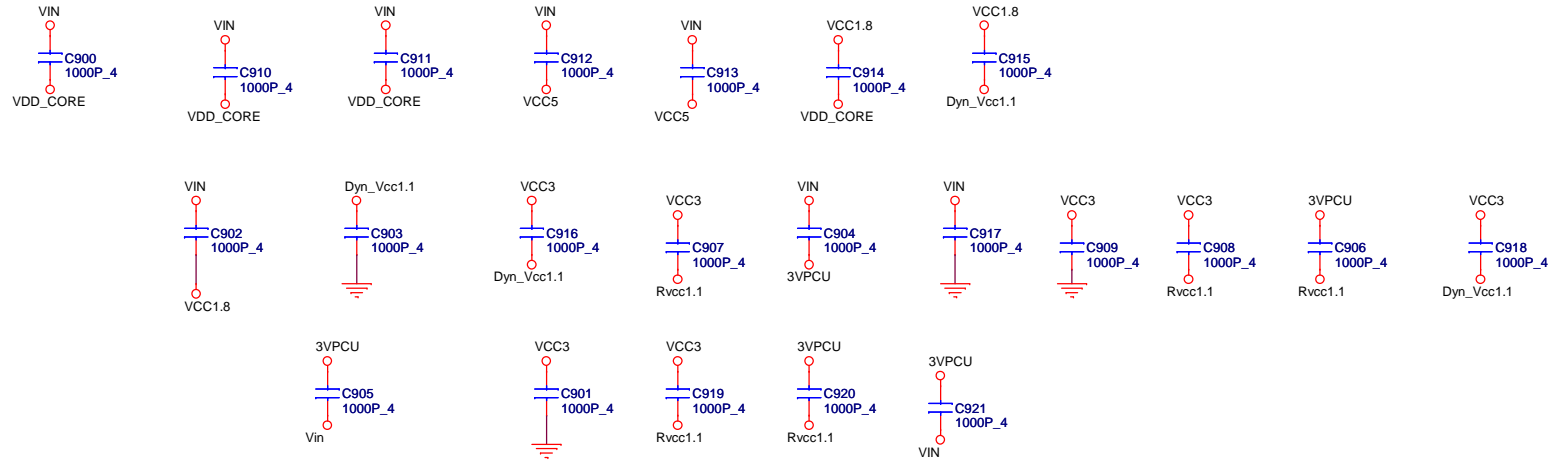

Power ripple

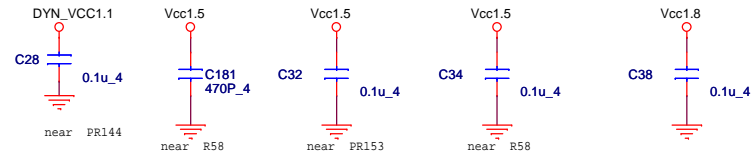

1.Level 1 Environment-related Substances Should NEVER be Used.
 2.Purchase ink, paint, wire rods, and Molding resins only from the business Partners that Sony approves as Green Partners.

Title		
Decoupling Cap		
Size B	Document Number	Rev 3A
	AMD	
Date: Saturday, March 20, 2010		Sheet 33 of 34

Power on Sequence required:

- SB800:**
 1, +3.3VDUAL ramp before +1.1VDUAL
 2, +3.3V ramp before +1.8V
 3, +1.8V ramp before +1.1V
 4, +3.3v ramp before +1.1v
 5, +3.3VALW_R ramping down time > 300us
 6, 50uS <= All power rails except +3.3VALW_R <= 40mS
 7, 100uS <= +3.3VALW_R <= 40mS

- RS880:**
 1, 0 <(+3.3V) - (-1.8v) < 2.1
 2, +1.8V ramp before +1.1V
 3, +1.1V ramp before VCC_NB

SB OUTPUT --- -NB_PWRGD
 NB_PWRGD_IN
 SB INPUT --- -SB_PWRGD

GROUP B
 PGOOD(DYN)
 DYN_VCC1.1
 VLDT(VCC1.1)
 VCC1.1
 VRM_PWRGD
 VCC0.9
 VDD_CORE (VRON)
 VDDNB_CORE

GROUP A
 PGOOD(2.5)
 VCC2.5 (CPU_VDDA_2.5_RUN)
 VCC1.5
 PGOOD(1.8)
 VCC1.8
 VCC3, VCC5
 MAINON
 SUSON
 PM_SLP_S3#

CPU MEM CTL & DDR3 SODIMM PWR#
 PGOOD(1.5)
 MEM_VTT

1.5VSUS

CPU_THM/SB/SB_SCL1/2
 SB_KB/SPI/LPC ROM PWR#
 EC_DNBSWON#
 RSMRST#

RVCC5, RVCC3, RVCC1.1

VDD_DUAL_EN

RVCC_ON

KBC is ready
 EC_DNBSWON#
 DNBSWON#

KBC is powered by A_VBAT & +3.3VALW
 AC_OK (ACIN detect)
 3VPCU

LDO:5.4V (from DCIN)
 +VIN/+12V_HD

A_VBAT

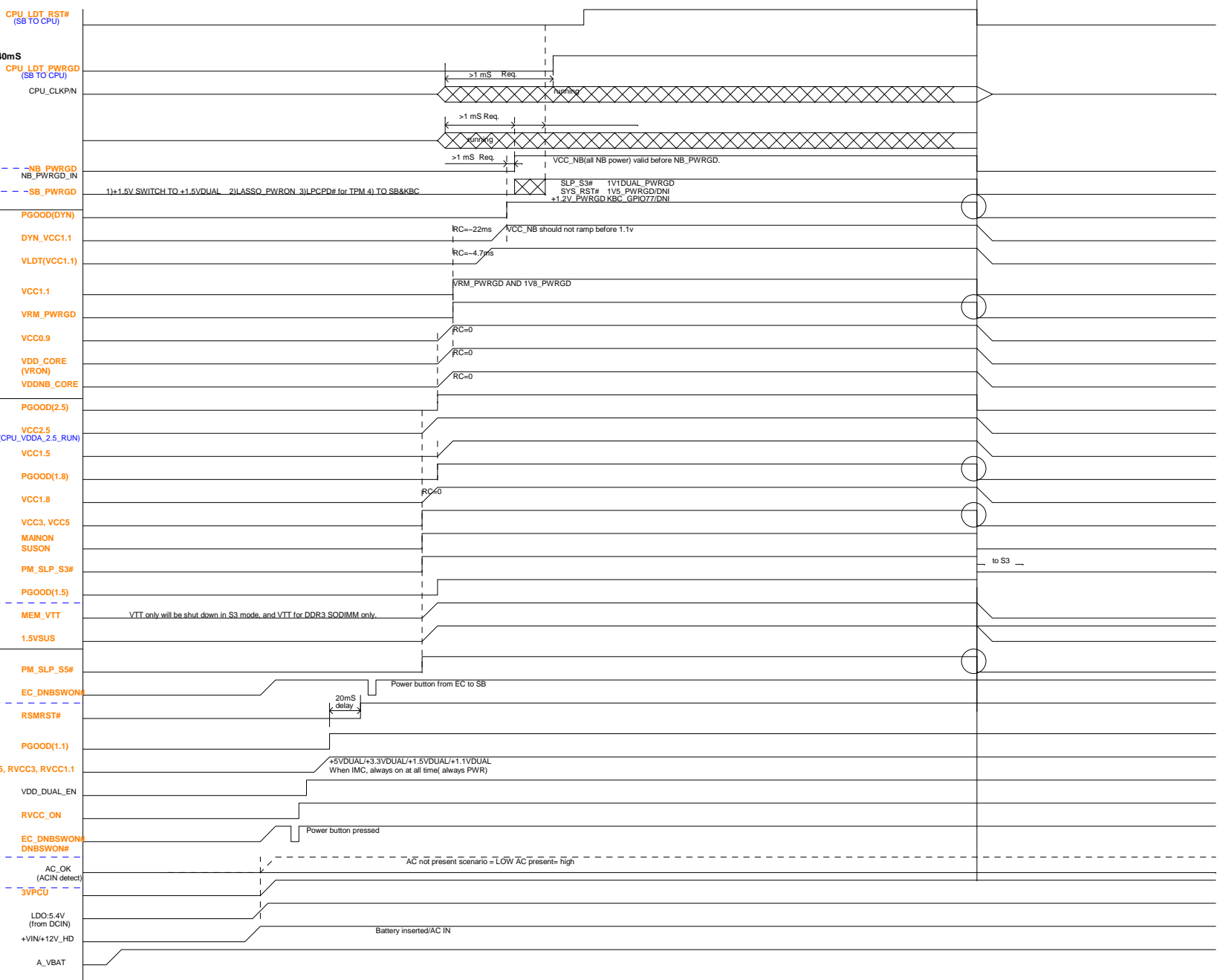

QUANTA COMPUTER

Change History

File			Rev	3A
Size	Document Number	AMD		
C	Date: Saturday, March 20, 2010	Sheet	34	of 34

1. Level 1 Environment-related Substances Should NEVER be Used.
 2. Purchase ink, paint, wire rods, and Welding resins only from the business Partners that Sony approves as Green Partners.

12/21

Page 10--R309 unmount
Page 8--R252 mount(CS00002JB38)RESISTOR CHIP 0 1/16W +-5%(0402)
Page 8--R101 & R106 unmount
Page 12--mount R184,R179,R289(CS31002FB26) RC0402,RC0402-C,0402-CNXT
Page 11--change R174,R175,R278,R146 to 10Kohm(CS31002JB28; RES CHIP 10K 1/16W +-5% (0402))
Page 21--LU1 change AL008111001 to AL008111002
Page 20--C29,C30 Mount 33PF CH03306JB04
Page 10--R20,R21 change CS00003J951 to bead CX8PG471000

12/22

Page 16--RP38 pin2 & pin 4 change net name :HDMI_TCXP & HDMI_TXCN
Page 16--C422 & C421 change net name :HDMI_TCXP & HDMI_TXCN
Page 32--H12 need change footprint

Page 32--H22 need change footprint

Page 32--remove H19

Page 32--Add H23 & H24

Page 10-- modify net name as NB_DISP_CLKN

12/23

Page 32--PU VCC5 TBDATA & TBCLK
Page 20--add 3 pcs 0ohm for EMI
Page 32--Add H23 footprint H-E315X315D102P2 & H24 footprint H-E315X315D102P2

Page 32--change footprint
H1 : H-E315X315D102P2-4
H2 : H-E315X630D102P2
H5 : H-E494X248D102P2
H6 : H-E217X358D102P2
H7 : H-E343X276D102P2
H12 : H-C236D102P2
H18 : H-E315X315D102P2-5
H22 : H-E315X198D102P2

12/24

Page 21 -- change 25MHz XTAL P/N:BG625000737
LC20 & LC21 change to CH03306JB04

12/25

Page 15 --camera power source 從USB power 改成RVCC5

12/28

Page 22 --U11(35001) ID pin 漏電問題, 請參考GD3加上diode, R108,R110,100 ohm PU改成2.2K;R272 10k ohm PU改成4.7k ohm
Page 22 --slp_s5#從EC pin 26改成106, 相當於Intel的slp_s4#, pin 26到106中間留一顆0 ohm接起來先不上
Page 11,15,22 --SB_PWRGD接到EC pin 16, 並改名為HW_PWRGD, 以方便辨識
Page 20 --change codec U34 P/N:AL000269007

12/29

Page 19 --remove Express card

1/15

1/13

Page18: MC8 unmount for MS card recognize issue
Page4 : Reverse CPU_VTT_SENSE PU VCC0.9
Page26: PR109 reserve for leakage issue

Page 3:con20 CPU_LDT_RST# add C31(reserve)
Page 21: LU1 pin 30 add LR4 10Kohm
Page 29: mount PR86
AJ069700T08-->IC CTRL(605P)SB820M
AJ075200T16--> IC CTRL(528P)RS880M
Page 16: Change CON13 footprint -->hdmi-c12806-11908-1-19p-v

1/19

Page 32: H19 add Spad-NE7-1-NP
Page 32 :H14 change footprint H-E315X315D110P2
Page 21: LU2 Change P/N DBBL5MLAN01

1/18

Page 3: T10 & T11 change footprint TP3050

1/4 Change footprint for layout

Page 20--U34 QFN48-7X7-5-49P-SMT
Page 26,25,25--PL16,PL19,PL20 CHOKE-ETQP4LR36WFC-4P-SMT
Page 30--PU9 HVSOF5-1_6-5-5P-SMT
Page 23--CON2 88513-2641-26P-L-SMT
Page 32--CON3 88513-0601-6P-L-SMT
Page 32
H2 O-NE7-2
H22 O-NE7-1
H6 O-NE7-3
H12 H-C236D102P2
H16 O-NE7-4
H1 H-TE295X295BE276X276D102P2
H18 H-E315X315D102P2-1
H5 H-E494X248D102P2-1
H7 H-E315X272D102P2

Page 21-- LU2 TRF-10-1-24P-SMT 加入-SMT
Page 18-- CN6 CARD-JBS010-2601-0-10P 移除-NB3
Page 24--PC142 ECAP10X6S 移除-Z01
Page 24--PL13,PL14 CHOKE-PCMB104T-R45MN-4P 移除-WK1

Add test point

Page3--U21 AF9 , AE9 , AC9 , AA9
Page11--U28 C4 , E7 , F7 , E8
Page22--U13 Pin21 , 25 , 17 , 20 , 48 , 50 , 51 , 52 , 110 , 111 , 112 , 35

*For screen will be clone mode bug
Page15--R265 change from 75 ohm to 140 ohm
R260 change from 75 ohm to 150 ohm
R254 change from 75 ohm to 150 ohm

*For Power on issue
Page28--PQ49 pin4 pin name change from VRM_PWRGD to MAINO

1/5

*Avoid system shutdown
Page11--CPU_THERMTRIP#上加一顆10K pull high到RVCC3

*For overload fail issue
Page 32--R130 change from 22ohm to F7 FUSE SMD 0.12A 48V
1/7

Page 15: R94, R99 change from 2.2k to 4.7K ohm for VEDS ARGB(4-5).
Page 14: remove no need cap for cost down
Page 11: R174;R175 PU power change from VCC3 to RVCC3
Page 11: RSMRST# schematic unmount

Page 6: Side port memory vref voltage PU low
Page 29: PU4 pin1 change pin name from PGOOD to VRM_PWRGD
Page 17: remove WLAN VCC1.5_MINI
Page 5: remove C34, C28
Page 32: Touch Pad CON3 pin reverse
Page 32: USB CON4 add GND Pin from 27~30

1/11

Page 18:CN6 change footprint mscard-cb1s-025-10p-1 for SMT request

Page 14:Add C37

Page 10:change Y7 P/N(BG332768542) and C480=18PF for timing accuracy
1/12
Page 15:CON7.10-->INT_LVDS_BLON: it is the PWM output to adjust the brightness.
U3.2-->INT_LVDS_ENA_BL: Enables Backlight for CPIS compliant LCD panels

Page 17:chang WLAN SW4 the same as SY2

Page 19:change BT con footprint AXK5F10537YG-10P-RUV --> add fix hole for SMT request

1/14

Page 20 --Add AMP_PD# schematic
Page 11:SUS_STAT# signal, it is OD; need pull up

QUANTA COMPUTER Change History AMD Rev 3A Date: Saturday, March 20, 2010 Sheet 35 of 34

1.Level 1 Environment-related Substances Should NEVER be Used.
2.Purchase ink, paint, wire rods, and Molding resins only from the business Partners that Sony approves as Green Partners.

1/21--->改版PVT
 Page 21:L1L1 pin26 ISOLATE# add 15kohm PD
1/22
 Page 10: Y7 change P/N:BG332768909
 C478 change to 18PF
 Page 10: change Y12 P/N: BG625000486
 and C430=C431 27PF for timing accuracy
 Page 21:L1Y1 Change 25MHz XTAL P/N:BG625000486(2nd:BG625000737)
2/10
 Page11: HW_PWRGD PD 10Kohm ---decrease impact on switch issue
 Page 20: ChangeR317,R323 from 22ohm to 0ohm for FSOV Fail issue
 Page 20: AMP_PD# power change from +5VA to 3VPCU
 Page 22: add INT_LVDS_ENA_BL pin for EC control backlight
 Page11: R174,R175 change from 10kohm to 2.2kohm
 Page14: C10 chagne from 10UF to 4.7UF
 Page15: chagne CON7 LVDS con
 Page19: chagne CON18 BT con
 Page17: chagne WLAN switch SW4
 Page20: chagne spk con CON10
 Page3: CPU_LDT_RST# add R69 short pad for debug
3/5
 Page16: change power source for CRT port
 Page16: change D9,D7 P/N and mount R266,R267
 Page21: LR8 umount
 Page22: R68 mount
3/8
 Page 24: Change PC 142 footprint ECAP10X6S-Z01
 Page 16: Change CON13 footprint & P/N:
 from hdmi-c12806-11908-1-19p-v to Hdmi-c12825-11908-1-19p-v
3/9
 Page 23: delete L27
 Page6 & Page11: remove all side port component
3/10
 Page 3:add C291 & C137(mount) change from 0.1u(CH4102M9B13) to
 180pf (CH11806JB09)
 for power noise
 Page 3:C31(mount) change from 33pf to 180pf (CH11806JB09)
 for power noise
3/11
 Page6 :R47 and R49 change from 0ohm to short pad
 Page8 :R245 change from 0ohm to short pad
 Page20 :remove R220
 Page20 :change C488,C491,C494 from AGND to GND
 Page 3 & 22 & 10: Change CPU Prochot schematic controlled by EC
 Page 3 mount R267
 Page 6:delete R56 & R63
 Page 8: change R83,R77,R65,R253,R71,R57,R91,R245 & R250 to short pad
 Page 8: delete R255,R252
3/12
 Page 9: delete R251,R249,C377,c191,c201,c195,c184,c196,R93,R89 for no side port
 Page 10: delete RP5,RP29,RP32,RP15,RP35,RP30
 Page 10: delete R300
 Page 11:delete RP27,SW1,RP25 (remove Panel ID set)
 Page 18:Change MR19,MR3,MR2,MR9,MR10,MR11,MR12,MR13,MR14,MR15,MR16,MR17,MR18,MR8 to short pad
 Page 24:Change PC142 footprint Ecap10x6s-SMT
 Page20 :delete R322,R329,R328
 Page21 :delete LR14
 Page21 :change LR6 to short pad
 Page 9: Change L7,L5,L6,L8,R80,R95 to short pad
 Page 13: Change R187,L10,L9,L15,L13,L28,L18,R169,L12,L11,L19,L14,L17,R127,R284,L26,R145 to short pad

3/15
 Page 20: reserve Q29 and R399,
 mount R367 for pop noise
 Page 20:Change R330、R321、R346、R347 from 1.5K ohm to 10K ohm for pop noise
 Page 20:add C343,C345,C346,C347 10uF for pop noise
 Page 8:R86 change from 30lohm to 1Kohm
 Page 11:R207& R208 from 100k ohm to 10k ohm
 Page 20:R363 umount
 Page 18:ML1 & MR4 change to short pad
 Page 19:delete Q16
 Page21:change con9 from DFTJ08FR085 to DFTJ08FR167
 Page22:U13 GPIO66 PL 10kohm(R159)
 Page 12:delete R176
 Page 15:delete R36
 Page 19:con18 delete T39,T40
 Page 20:delete R317,R323
 Page 20:R214 change from 0ohm to short pad
 Page 22:delete R68
 Page 3:delete con20 & C31 & C267
 Page 3:reserve C182 0.1uF
 Page 3:R69 change to short pad
3/16
 Page 23:reserve U42 ESD part
 Page 32:change con4 抽屜式
 Page 32:change H13,H15,H17,and add H23,H24 NUT
 Page 19:Reverse C786, C787, C788 FP for ESD
 Page 20:C342 umount
 Page 20:CPU_PROCHOT# add C312
 Page 9:mount C217 for DYN_VCC1.1 power ripple too large
3/17
 Page20:R206,R205,R215,R210,R209,R222,R211,R217,R223 change to short pad
 Page 3:reserve C184 0.1uF
 Page21:change LC23 from 1000P/2KV to 1000P/3KV
 Page 3:delete R51,R50
 Page 4:delete R11
 Page20:L1-L4 change P/N to CX121T20100
 Page 16:delete RP38
 Page 18:delete MRP1
 Page 22:delete R155
 Page 3:delete R238
 Page 15:delete R355
 Page 15: R273 change from CS41002JB20 to CS41002FB28
3/20
 Page 32: change R236,R237 from 150 ohm to 75ohm for two color LED

1.Level 1 Environment-related Substances Should NEVER be Used.
 2.Purchase ink, paint, wire rods, and Molting resins only from the business Partners that Sony approves as Green Partners.

 Quanta Computer Inc. PROJECT : NE8		Rev
		3A
CHANGE LIST 2		
Date:	Saturday, March 20, 2010	Sheet 36 of 42