

# AX1 INTEL UMA/DISCRETE SYSTEM DIAGRAM

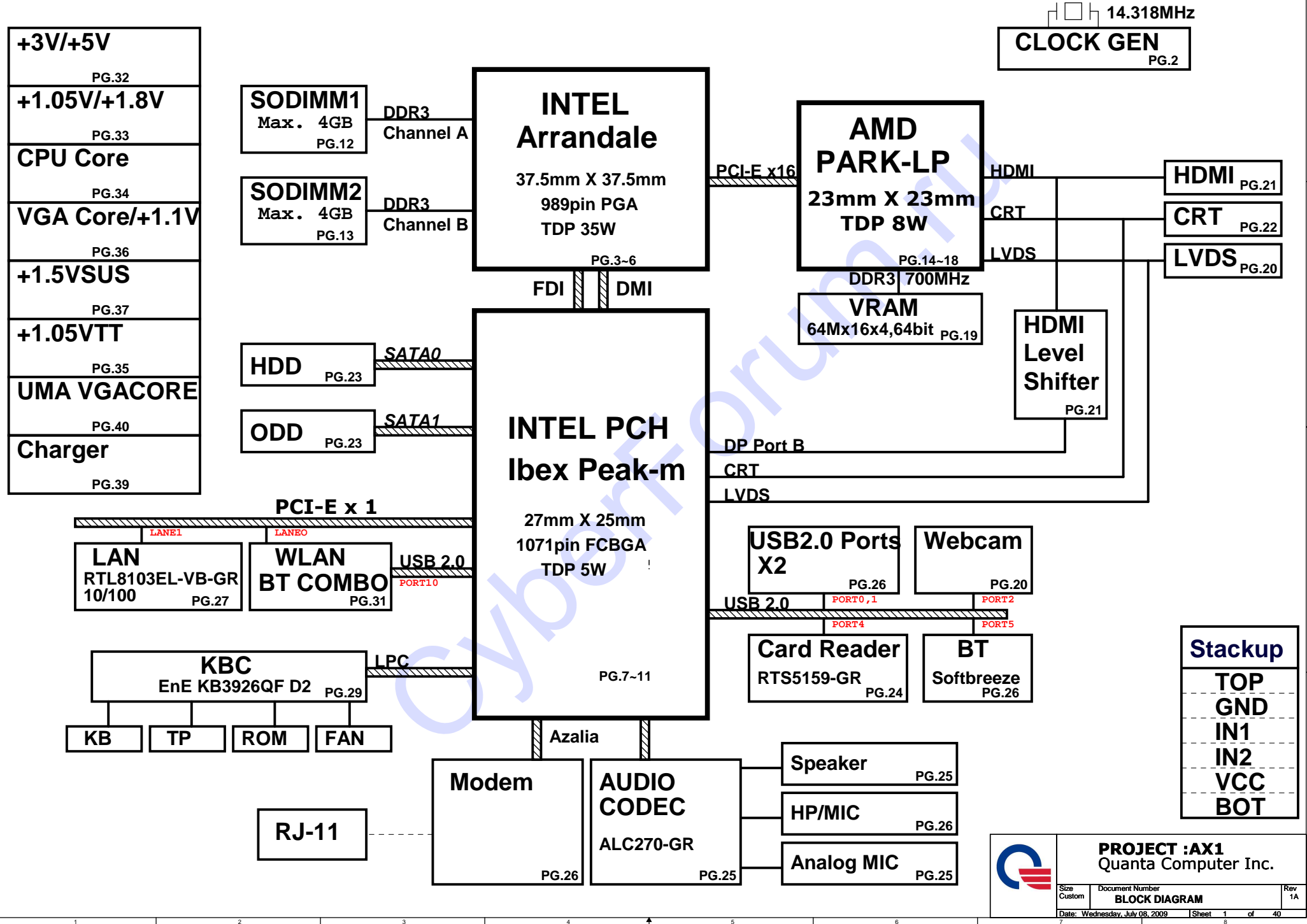

**PROJECT :AX1**  
Quanta Computer Inc.

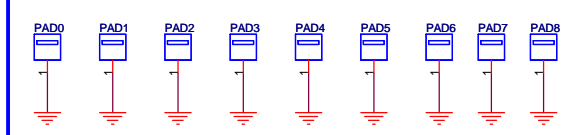
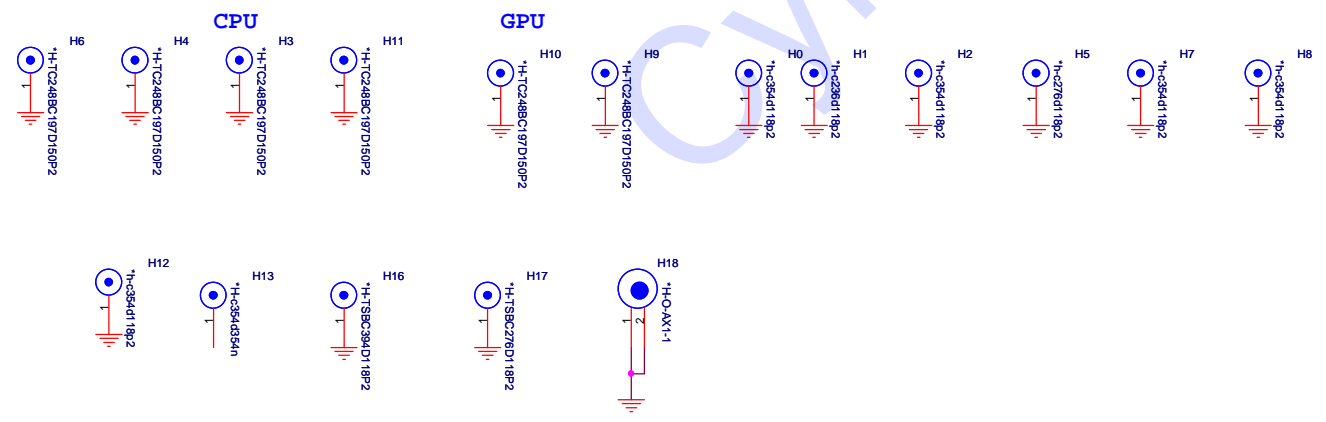
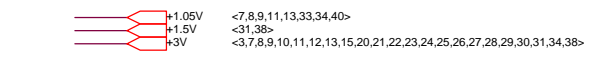
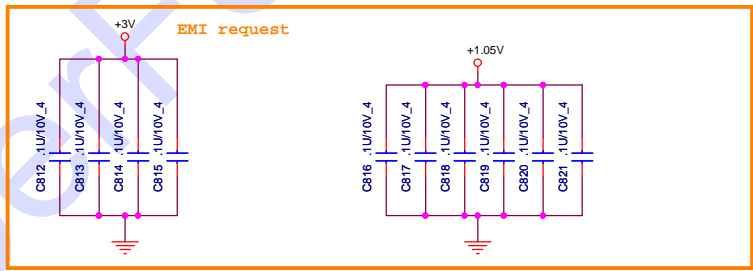
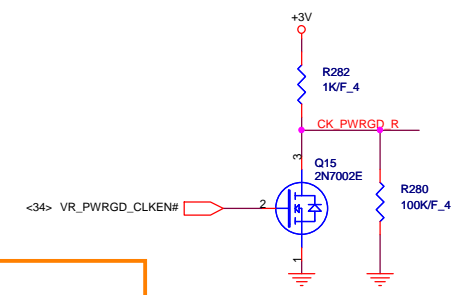
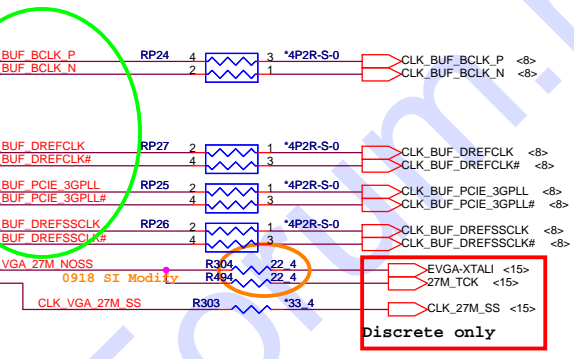
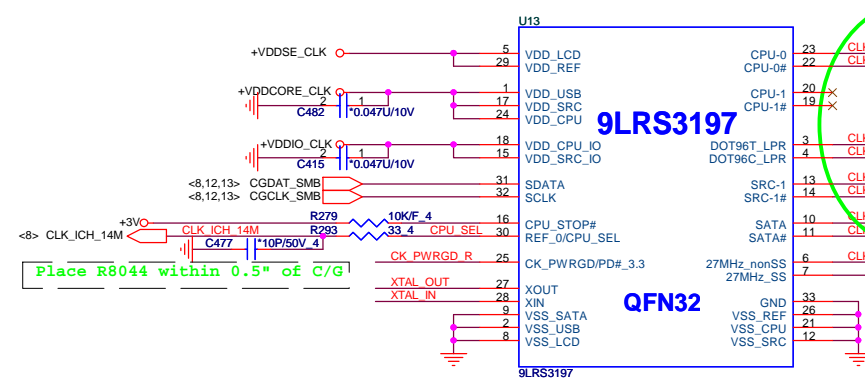
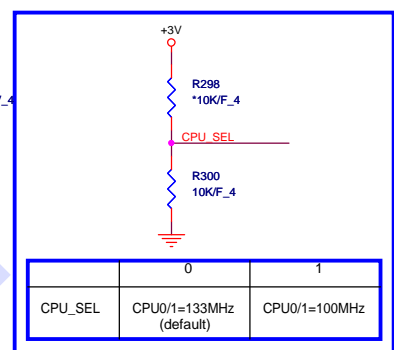
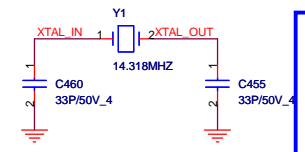
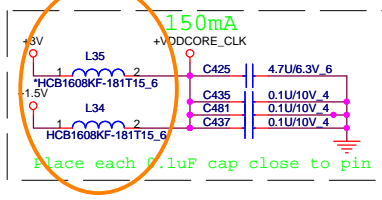
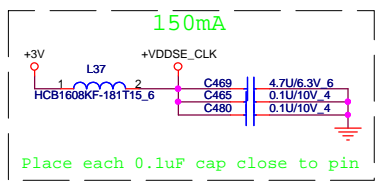
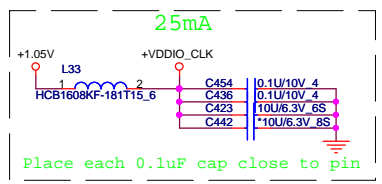

**PROJECT :AX1**  
 Quanta Computer Inc.

Size Custom	Document Number <b>Clock Gen(9LRS3197)/HOLES</b>	Rev 1A
Date: Thursday, November 12, 2009		Sheet 2 of 40

Ra	DIS	UMA
Rb	NA	0 ohm
Rc	0 ohm	NA

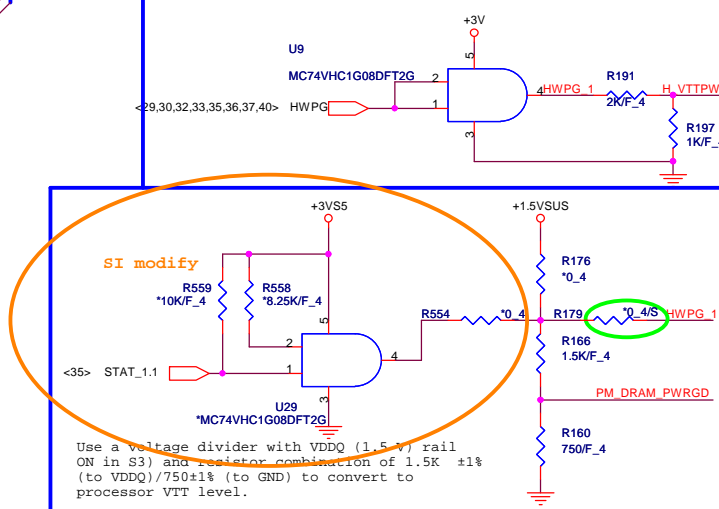
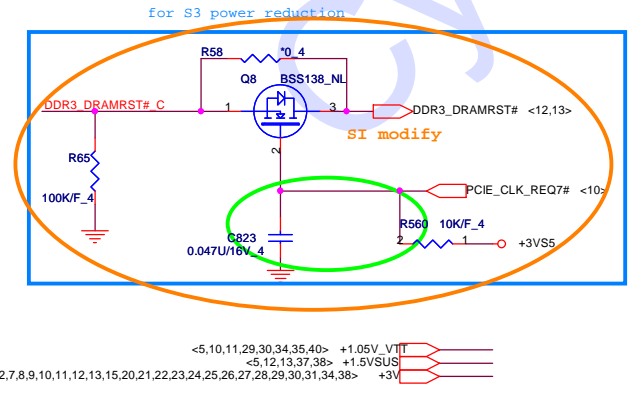
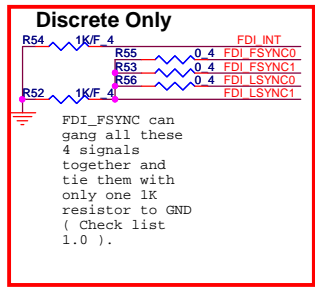
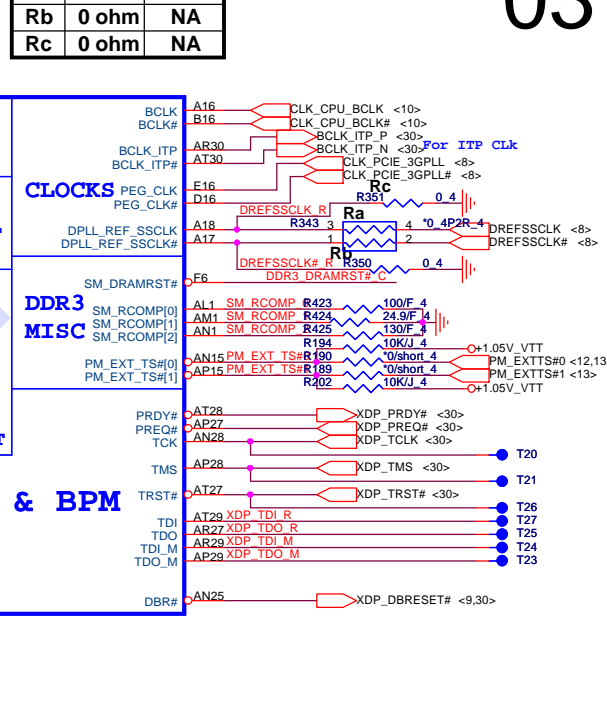
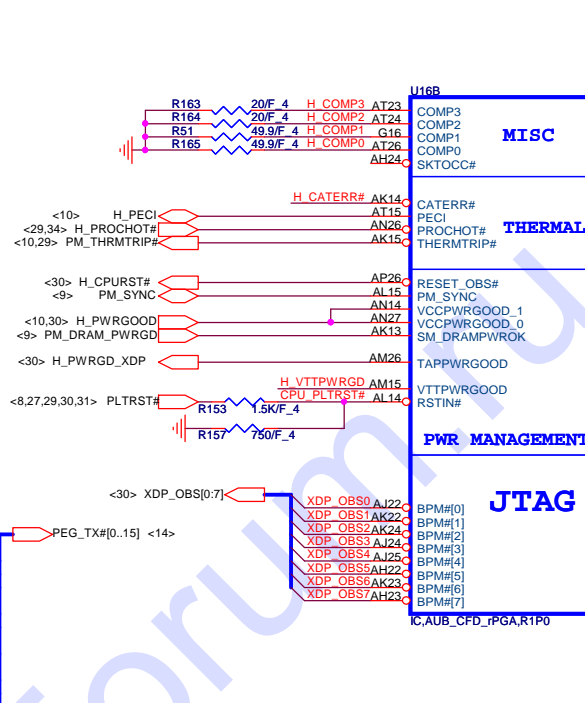
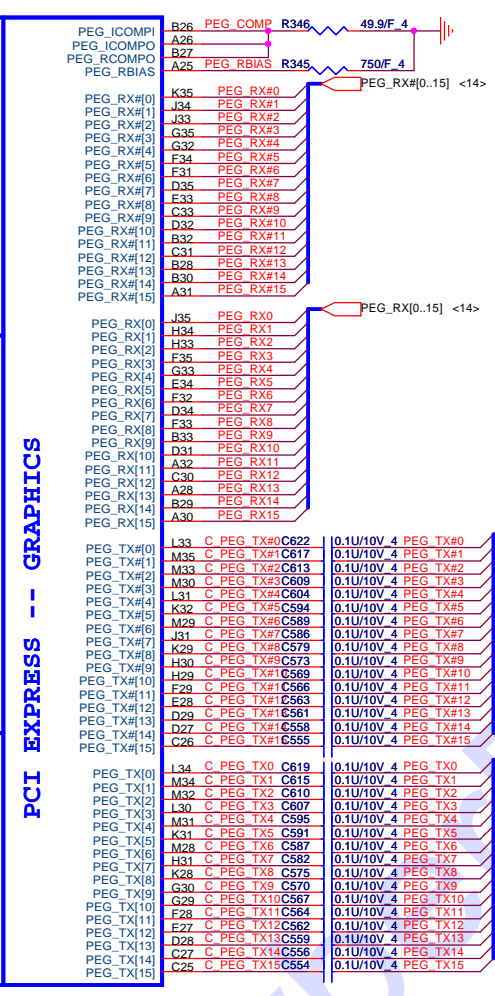
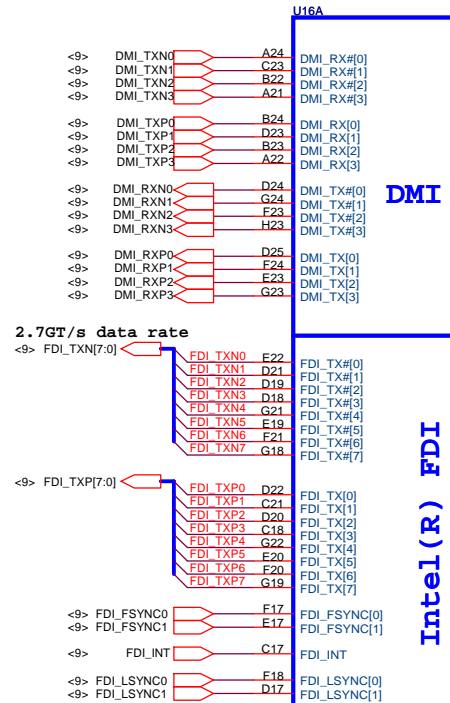

Scan Chain (Default)	STUFF -> Ra, Rc, Re NO STUFF -> Rb, Rd
CPU Only	STUFF -> Ra, Rb NO STUFF -> Rc, Rd, Re
GMCH Only	STUFF -> Rd, Re NO STUFF -> Ra, Rb, Rc

**PROJECT :AX1**  
Quanta Computer Inc.

Size Custom	Document Number	Rev 1A
	<b>PROCESSOR 1/4(HOST&amp;PEX)</b>	
Date: Monday, November 30, 2009	Sheet 3	of 40

AUBURNDALE/CLARKSFIELD PROCESSOR (DDR3)

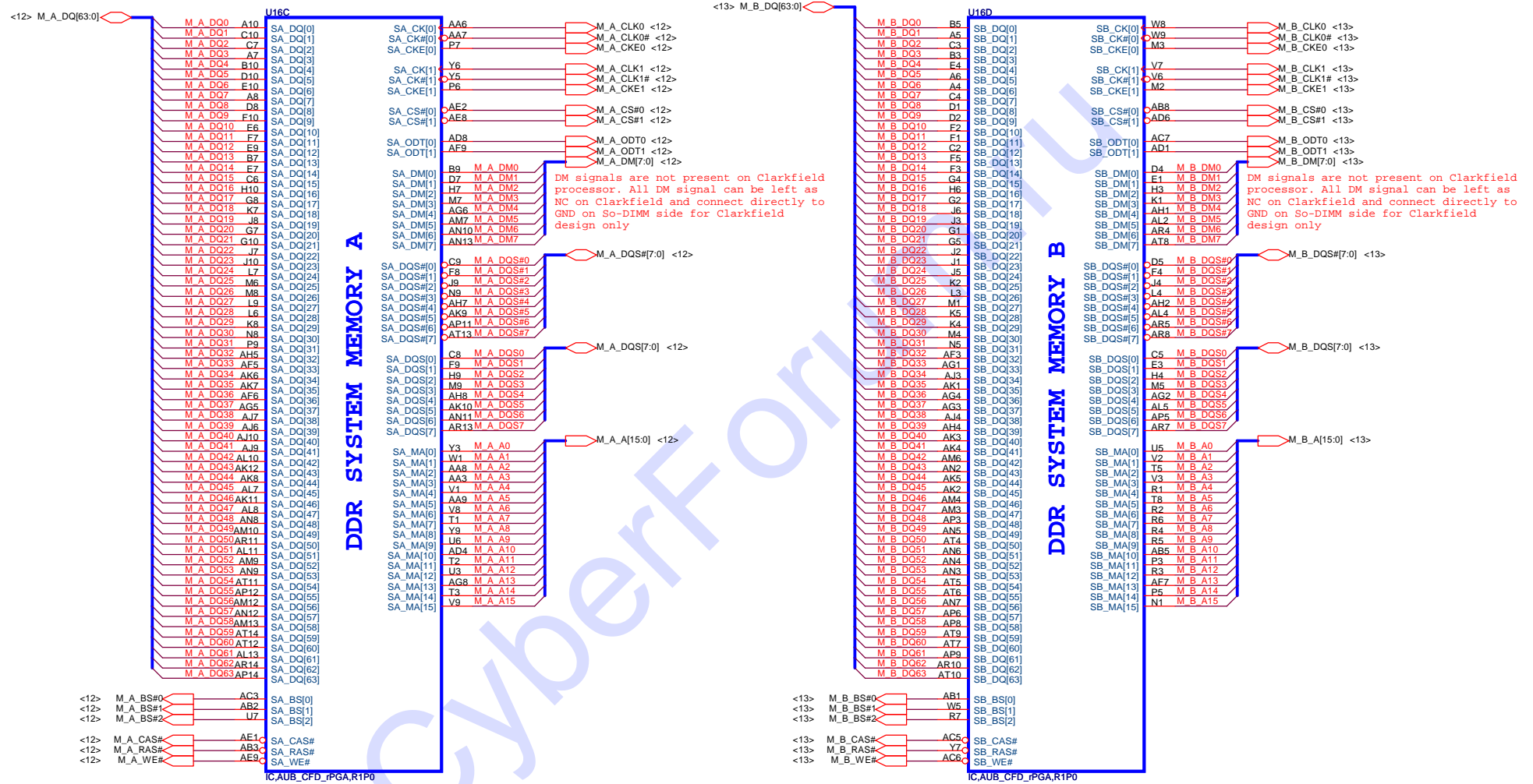

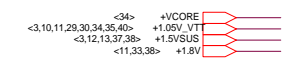
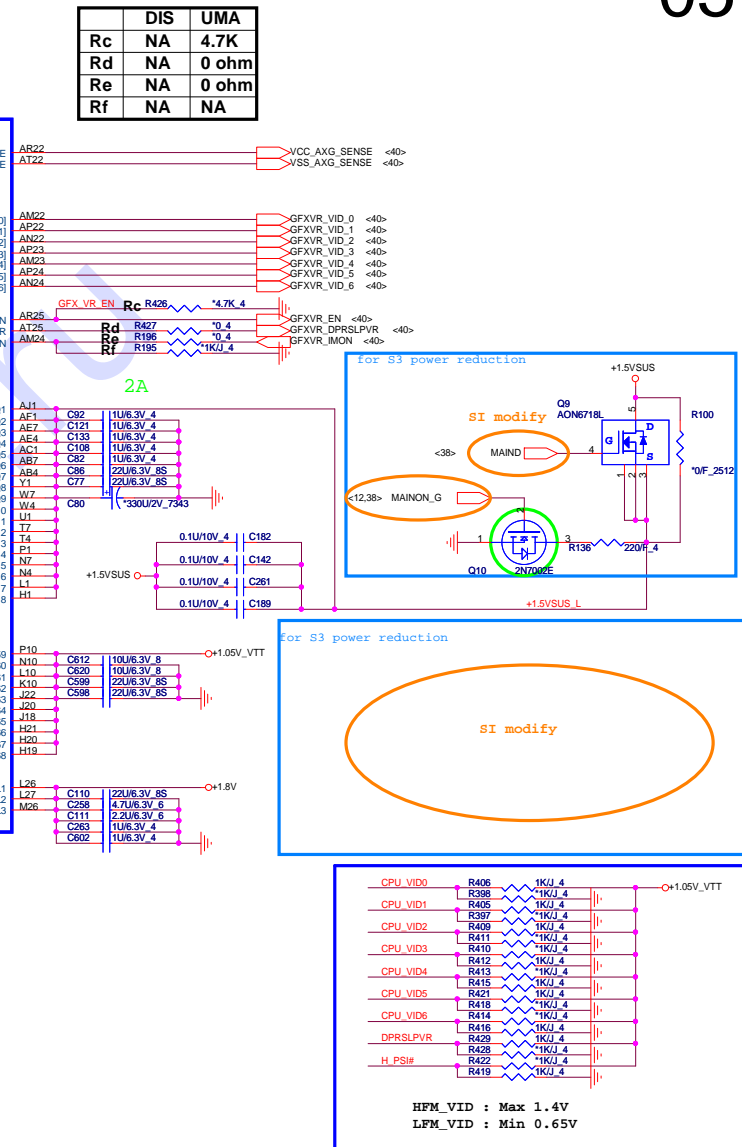
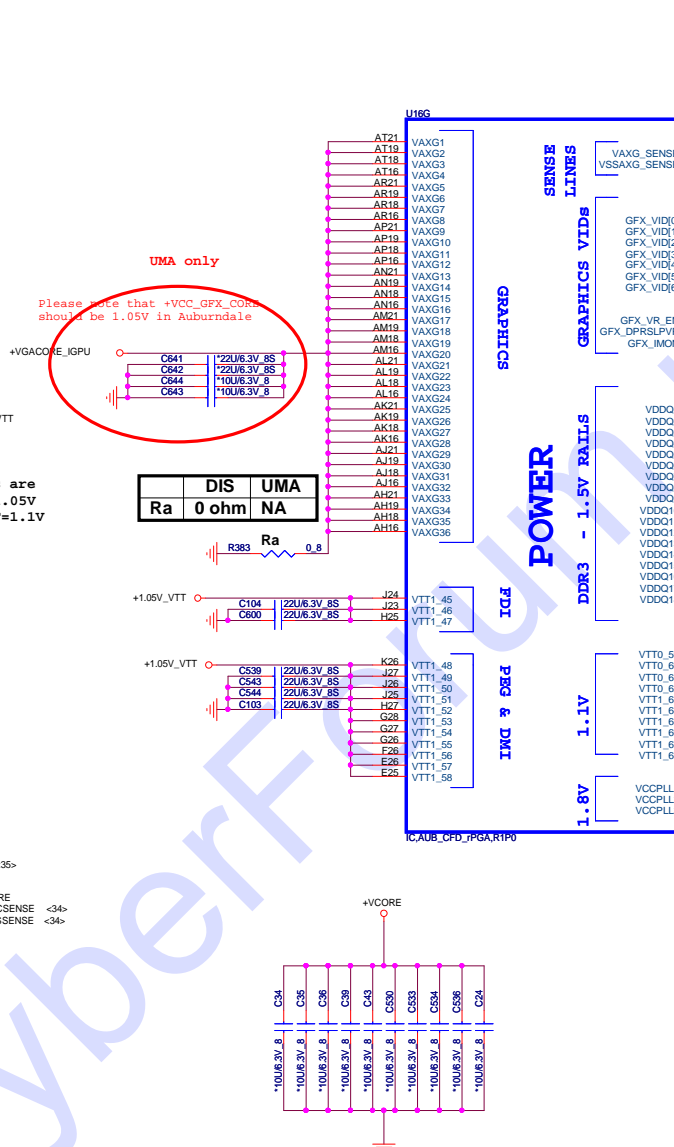
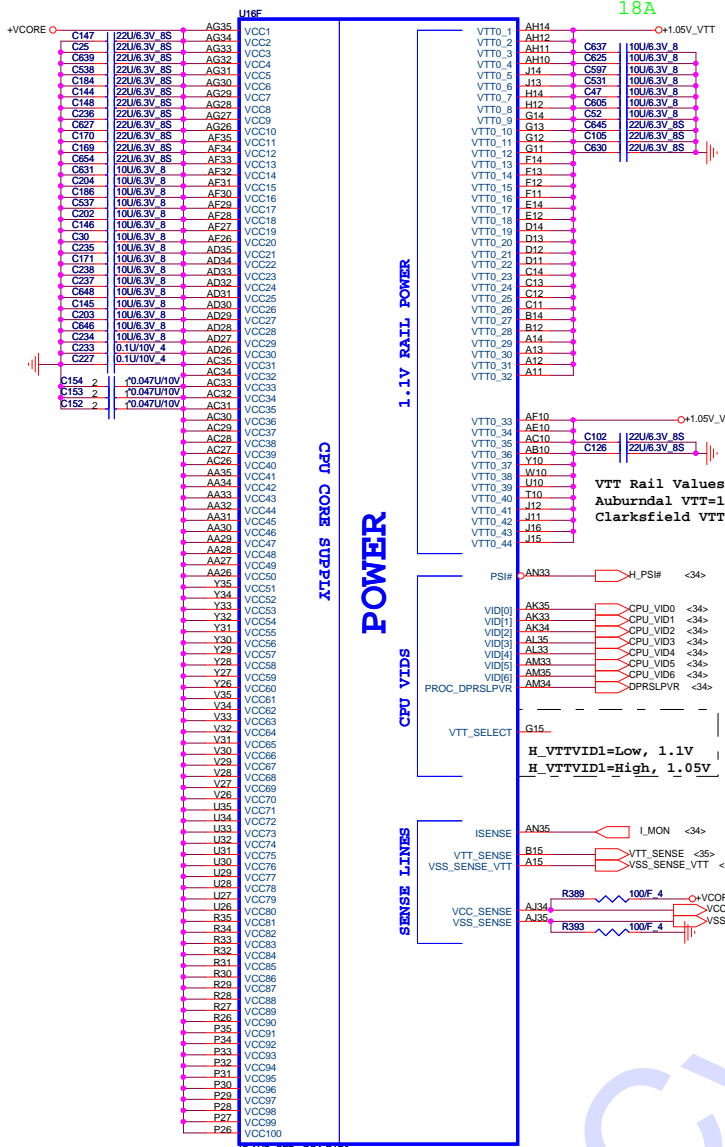



AUBURNDALE/CLARKSFIELD PROCESSOR (GND)

AUBURNDALE/CLARKSFIELD PROCESSOR( RESERVED, CFG)

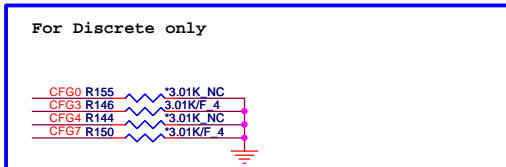
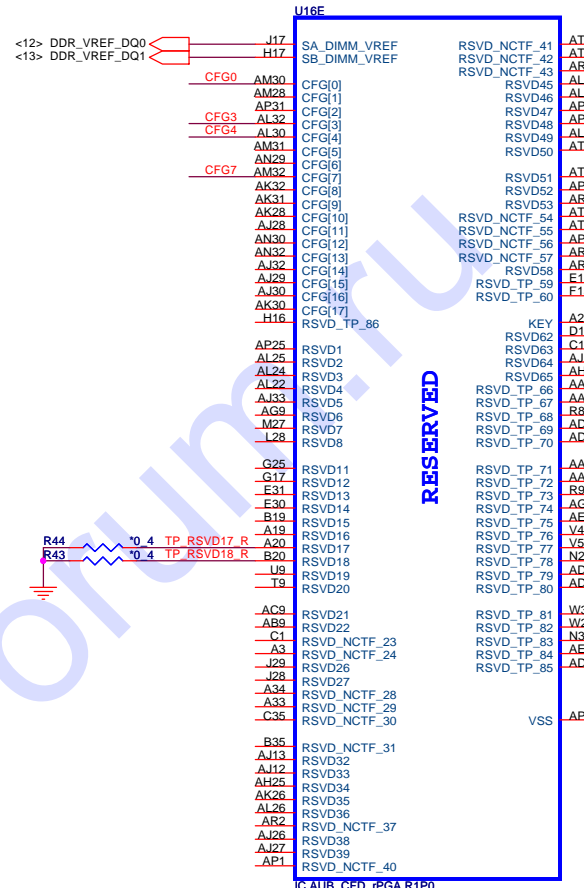
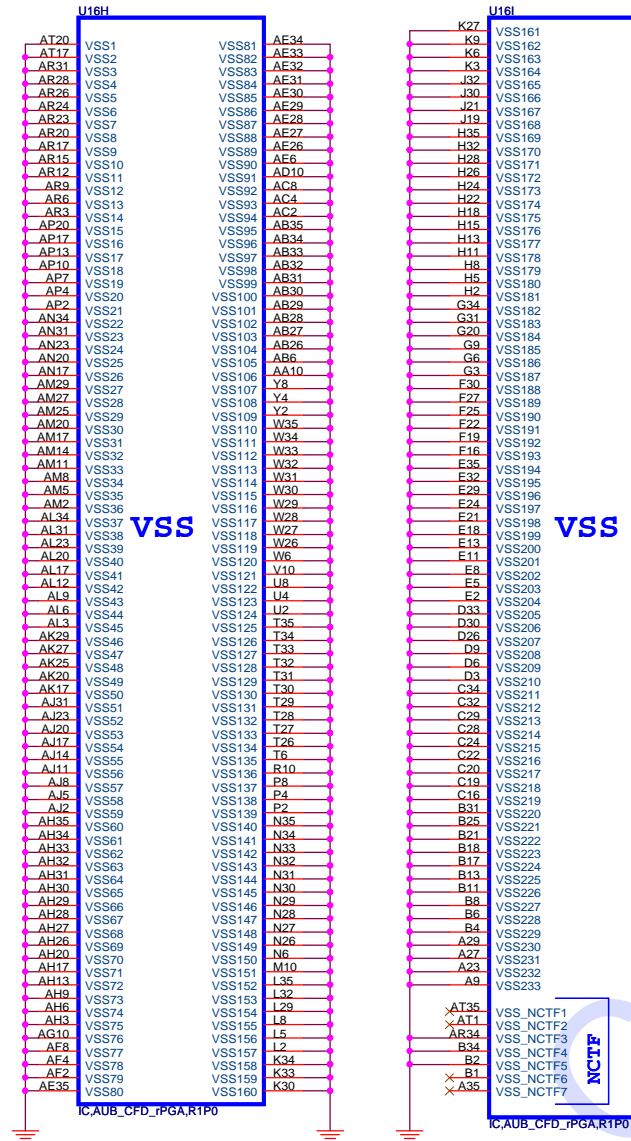

The Clarkfield processor's PCI Express interface may not meet PCI Express 2.0 jitter specifications. Intel recommends placing a 3.01K +/- 5% pull down resistor to VSS on CFG[7] pin for both rPGA and BGA components. This pull down resistor should be removed when this issue is fixed.

	1	0
CFG4 (Display Port Presence)	Disabled; No Physical Display Port attached to Embedded Display Port	Enabled; An external Display port device is connected to the Embedded Display port
CFG0 (PCI-Epress Configuration Select)	Single PEG	Bifurcation enabled
CFG3 (PCI-Epress Static Lane Reversal)	Normal Operation	Lane Numbers Reversed 15 -> 0, 14 -> 1

CFG[ 1:0 ] - PCI\_Epress Configuration Select  
 \* 11= 1 x 16 PEG  
 \* 10= 2 x 8 PEG

**PROJECT :AX1**  
**Quanta Computer Inc.**

Size Custom Document Number PROCESSOR 4/4 (GND) Rev 1A  
 Date: Thursday, November 12, 2009 Sheet 6 of 40

INTVRMEN - Integrated SUS 1.1V VRM Enable  
High - Enable Internal VRs

**IBEX PEAK-M (HDA,JTAG,SATA)**

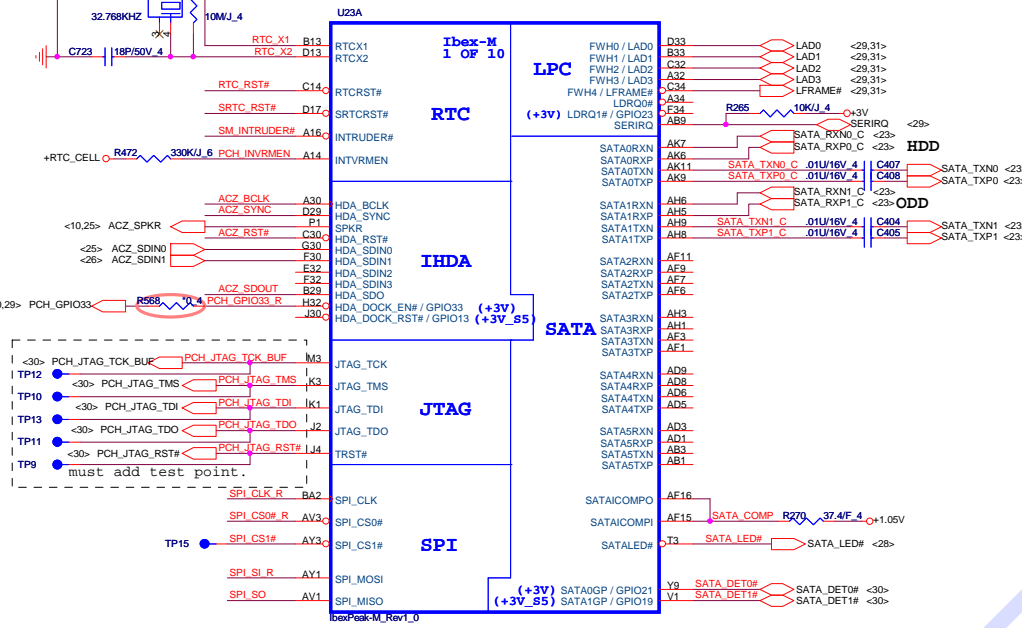

1205 The SATALED# signal is open-collector and requires a weak external pull-up (8.2 k to 10 k ) to +V3.3.

**UMA CRT,LVDS&HDMI signals**

**IBEX PEAK-M (LVDS,DDI)**

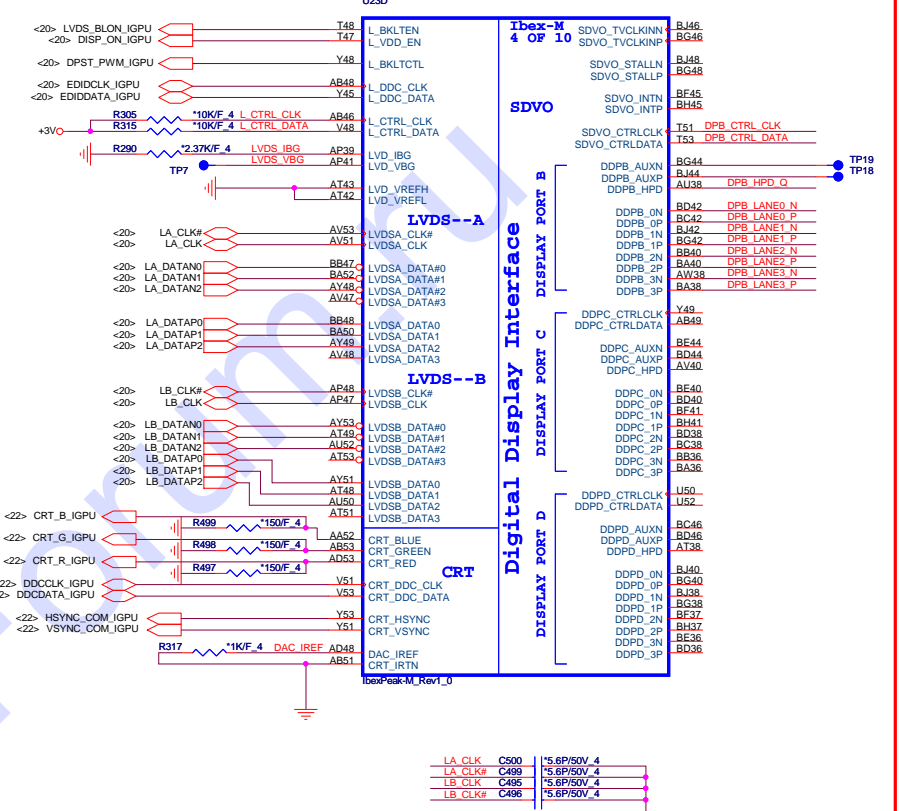

**UMA HDMI signals**

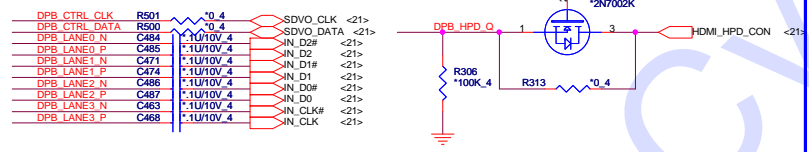

**For AUDIO**



**For MDC**



**RTC**

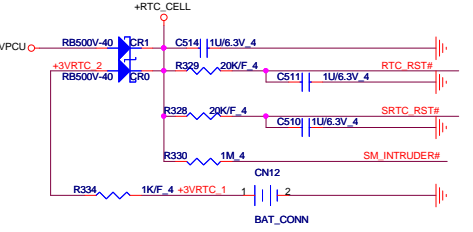

**4M byte SPI ROM**

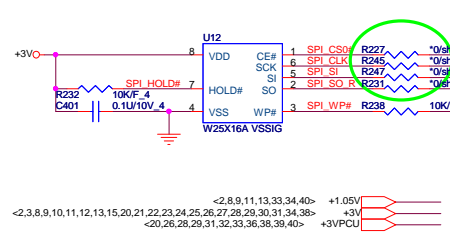

Vendor	PN
Socket	DG008000031
WINBOND	AKE39ZPN00
MAX	AKE39FPN00

**PROJECT :AX1**  
Quanta Computer Inc.

Size Custom	Document Number	Rev
	<b>PCH 1/5 (SATA,HDA,LPC)</b>	1A
Date: Monday, November 30, 2009	Sheet 7	of 40





IBEX PEAK-M (DMI,FDI,GPIO)

IBEX PEAK-M (PCI,USB,NVRAM)

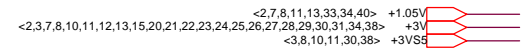
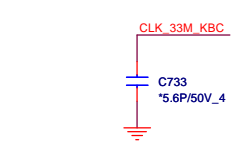
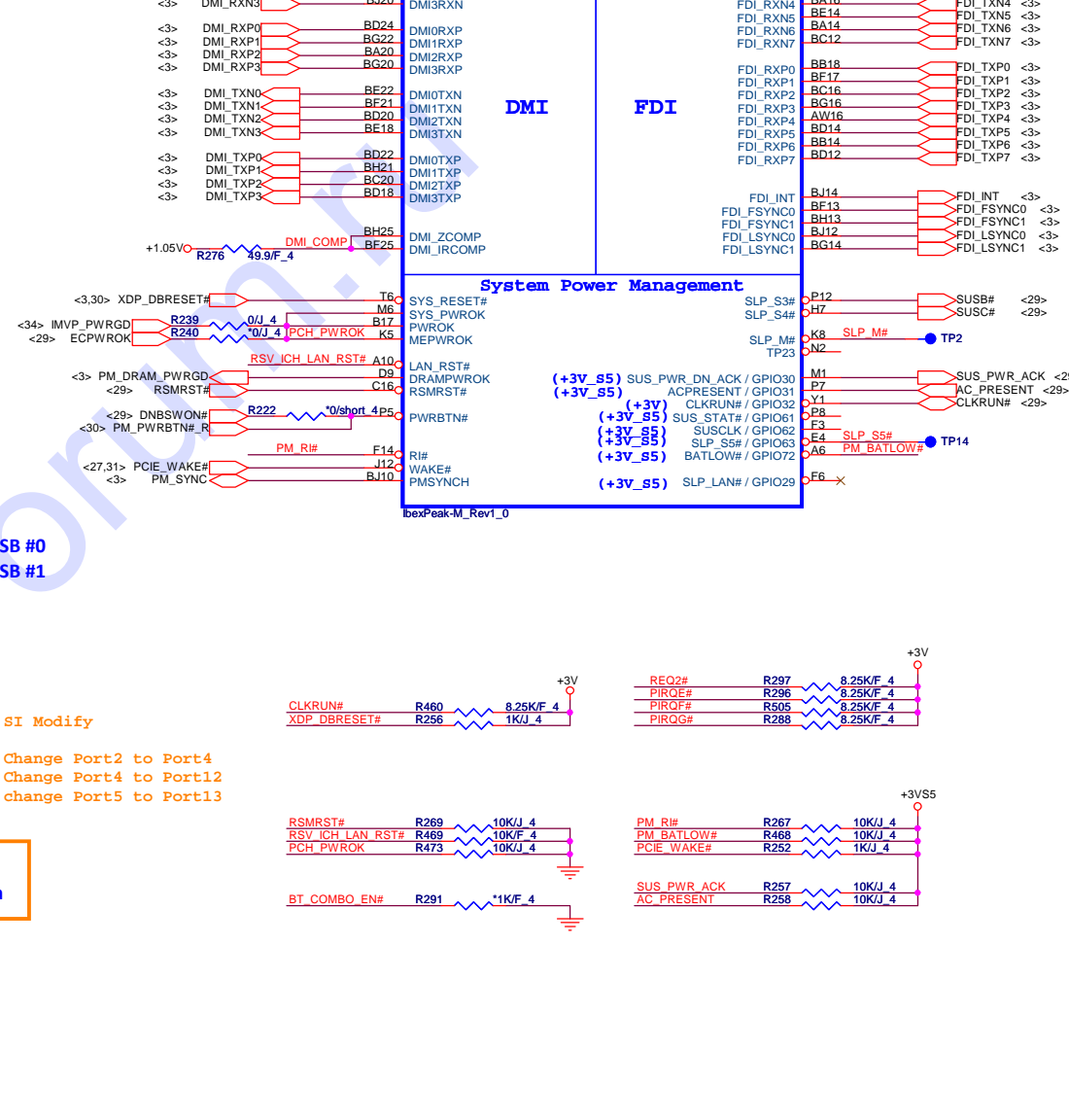
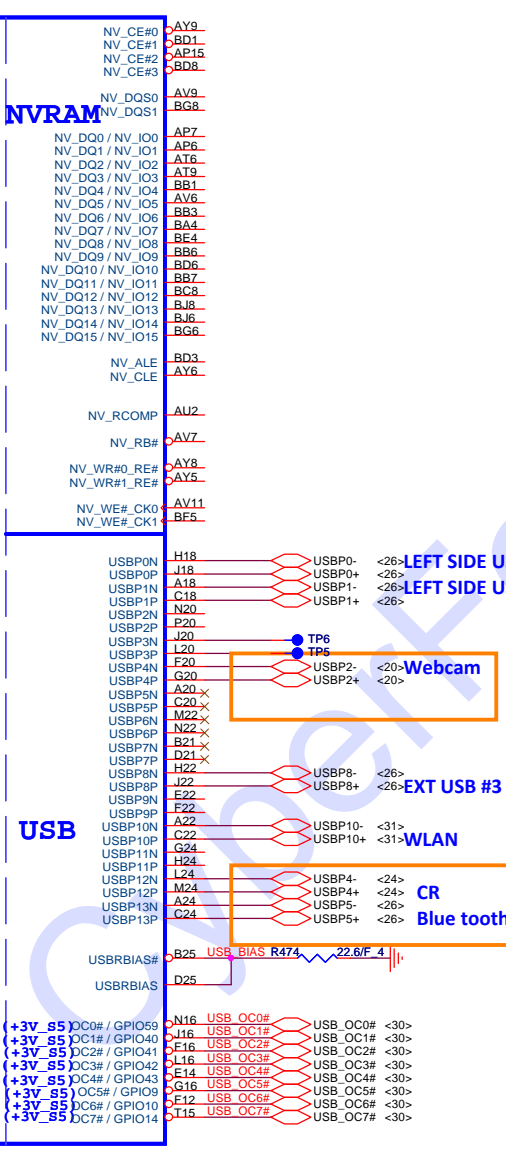
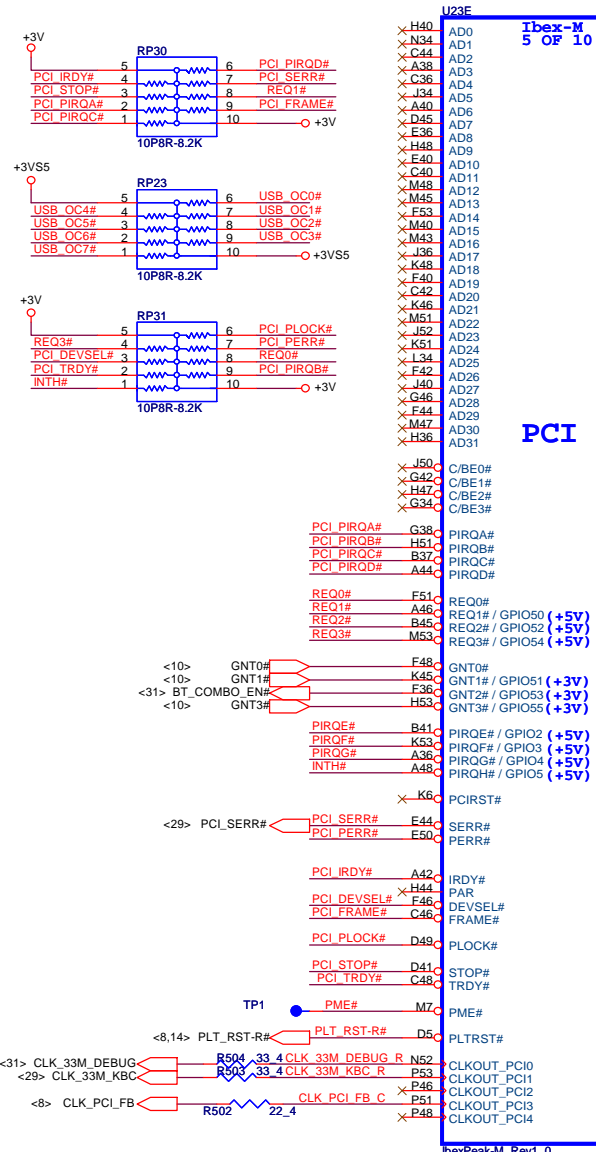

**PROJECT :AX1**  
**Quanta Computer Inc.**

Size Custom Document Number **PCH 3/5 (PCI,ONFI,USB,DMI)** Rev 1A  
 Date: Monday, November 30, 2009 | Sheet 9 of 40

# IBEX PEAK-M (GPIO,VSS\_NCTF,RSVD)

# IBEX PEAK-M (GND)

10

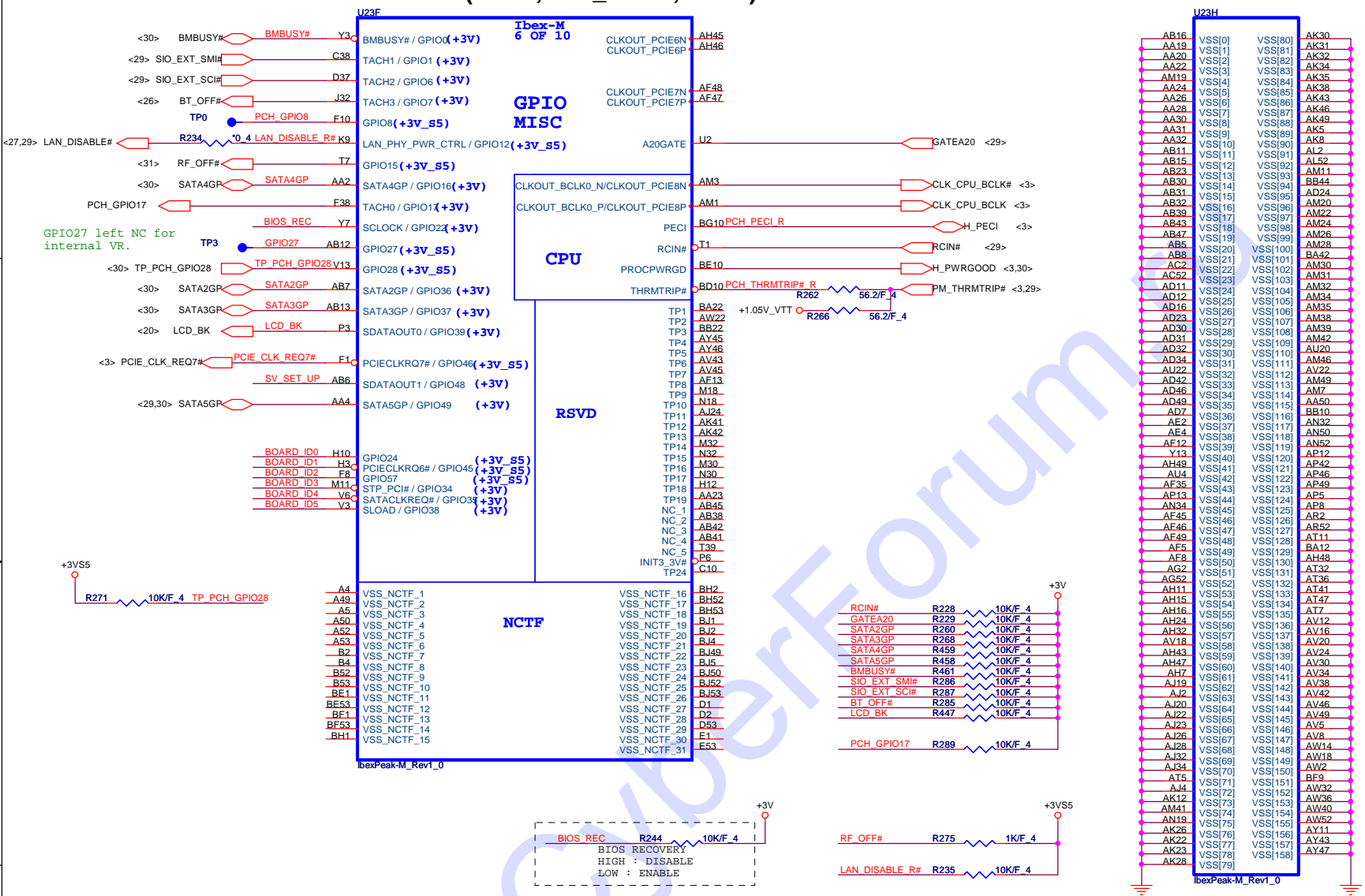

**A16 swap override Strap/Top-Block Swap Override jumper**

GNT3#

Low = A16 swap override/Top-Block Swap Override enabled  
High = Default

SV SET UP R259 10K/F 4 +3V

SV\_SET\_UP 1-X High = Strong (Default)

GNT0# R302 1K/F 4  
GNT1# R506 1K/F 4

**Boot BIOS Strap**

PCI_GNT0#	GNT#1	Boot BIOS Location
0	0	LPC
0	1	Reserved (NAND)
1	0	PCI
1	1	SPI

**Danbury Technology Enabled**

NV\_ALE High = Enable  
Low = Disable

**DMI Termination Voltage**

NV\_CLE Set to Vcc when LOW  
Set to Vcc/2 when HIGH

**No Reboot Strap**

## BOARD ID SETTING

Board ID5: For identify UMA and DIS  
Board ID4: For identify FF and DF  
Board ID3: Reserve  
Board ID2: Reserve  
Board ID1: Reserve

Board ID	ID0	ID1	ID2	ID3	ID4	ID5
UMA FF	0	0	0	0	0	0
UMA DF	0	0	0	0	1	0
DIS	0	0	0	0	0	1

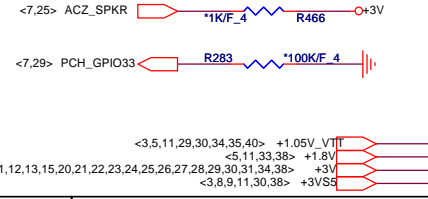
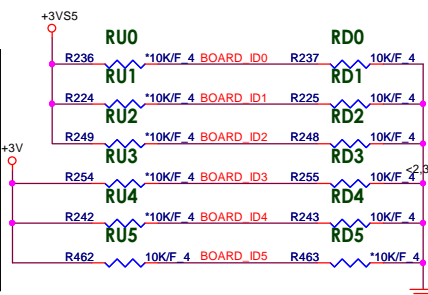

**PROJECT :AX1**  
Quanta Computer Inc.

SI modify  
Uninstall on UMA  
Install on DIS

	DIS	UMA
Ra	0 ohm	NA
Rb	NA	0 ohm
Rc	0 ohm	NA
Rd	NA	0 ohm

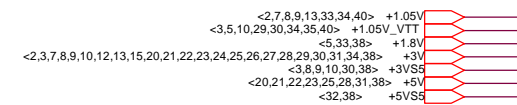
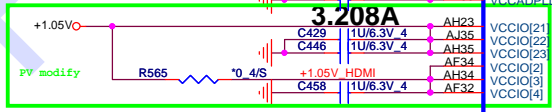
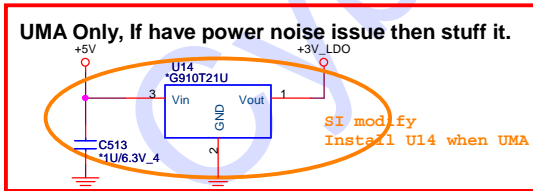
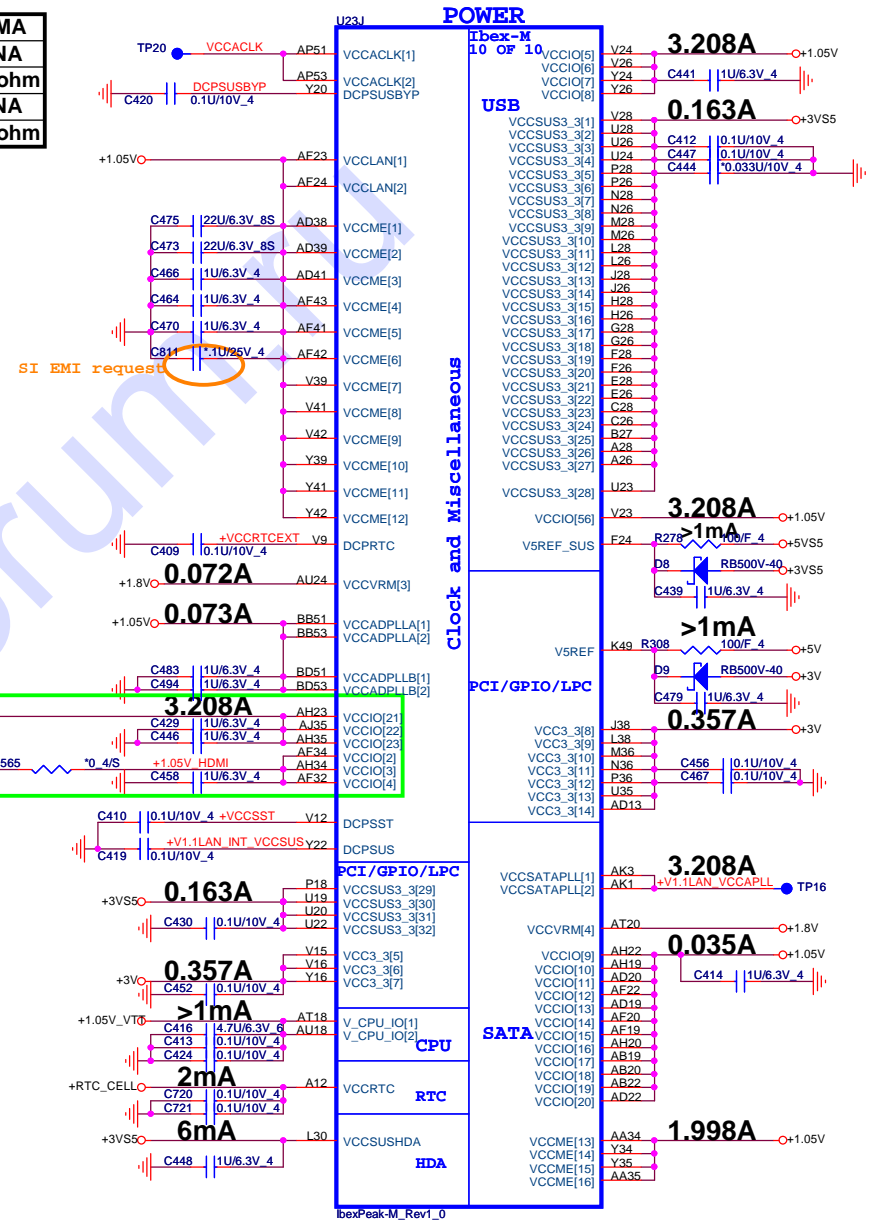
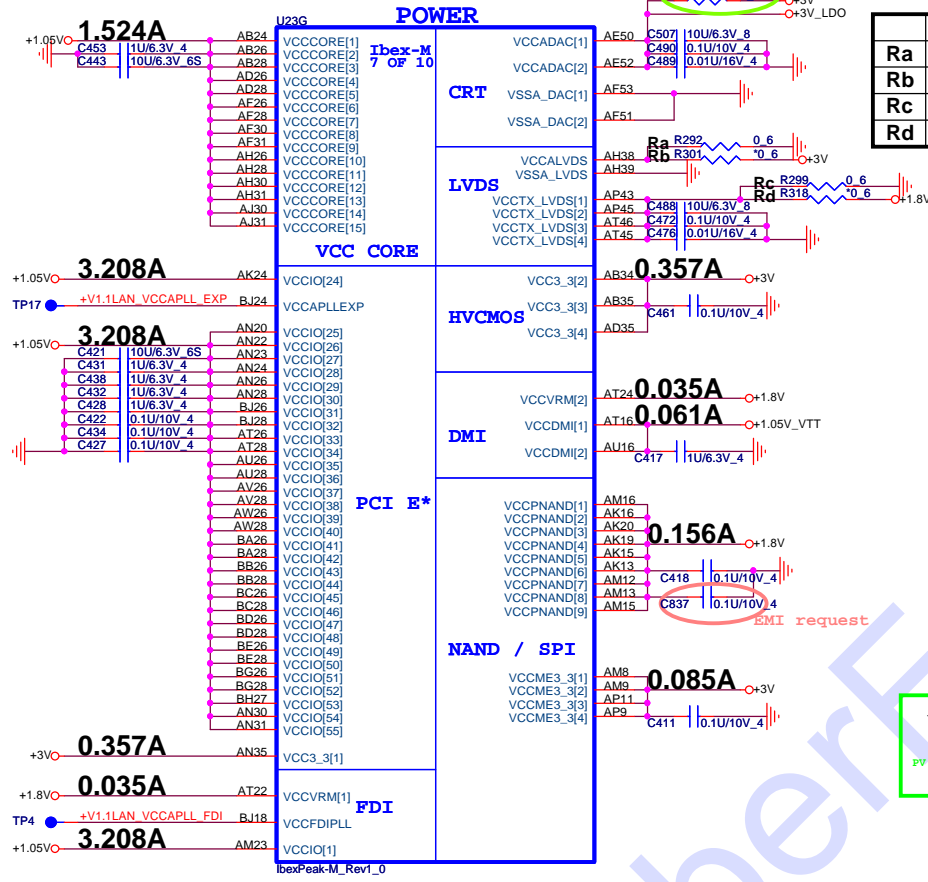

**PROJECT :AX1**  
Quanta Computer Inc.

Size Custom	Document Number <b>PCH 5/5 (POWER)</b>	Rev 1A
Date: Thursday, November 12, 2009   Sheet 11 of 40		

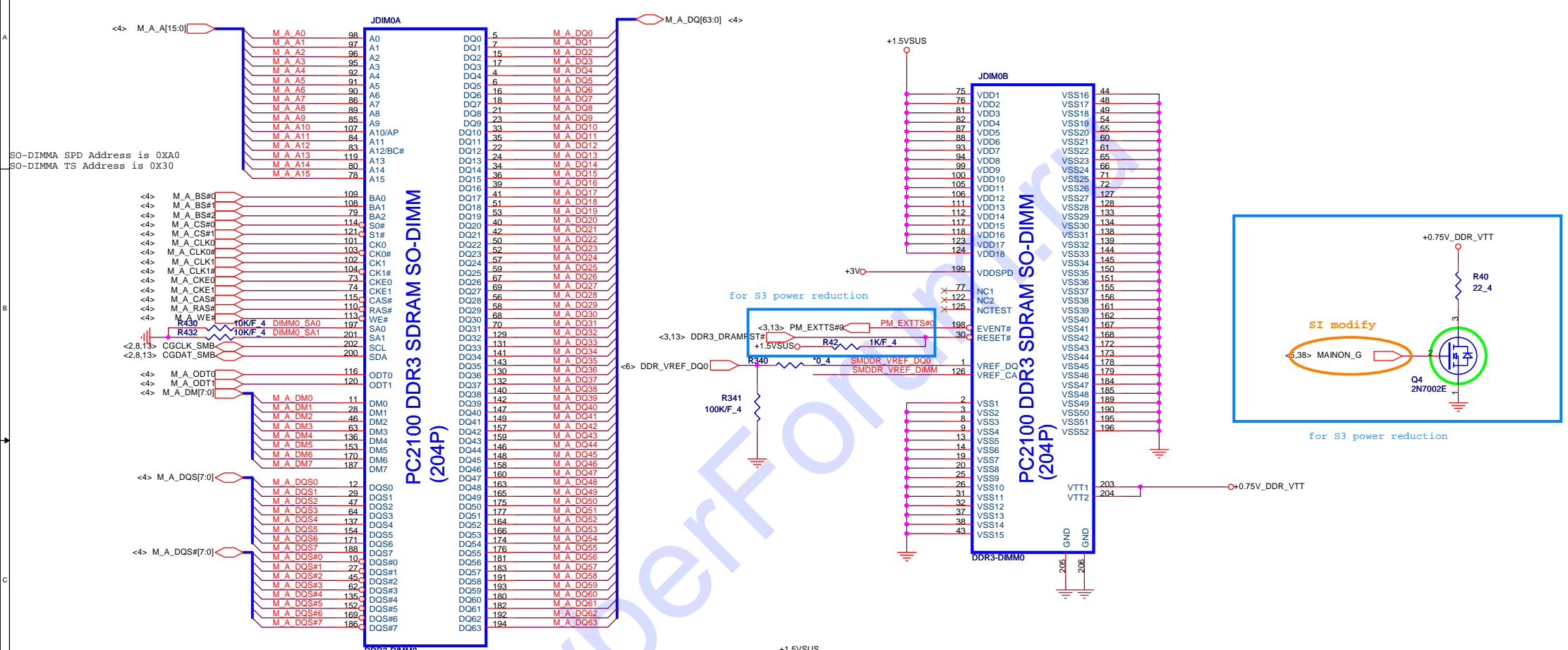

**Place these Caps near So-Dimm0.**

Some Projects replace 10UF 0805 by 4.7UF 0603  
It can cost down 30%

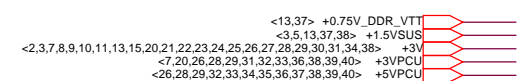
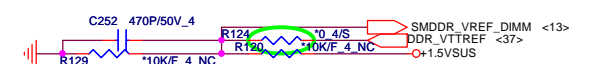
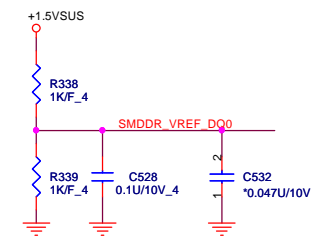
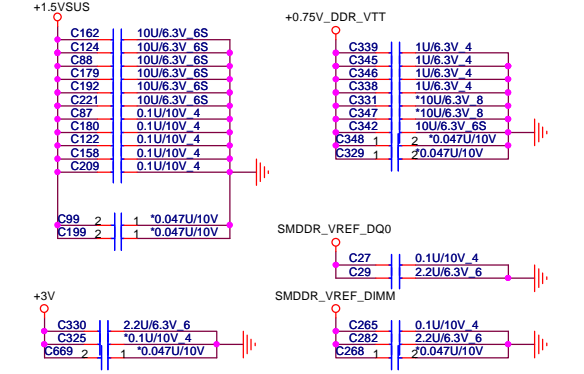

**PROJECT :AX1**  
**Quanta Computer Inc.**

Size Custom	Document Number <b>DDR3 DIMM-0</b>	Rev 1A
Date: Thursday, November 12, 2009   Sheet 12 of 40		



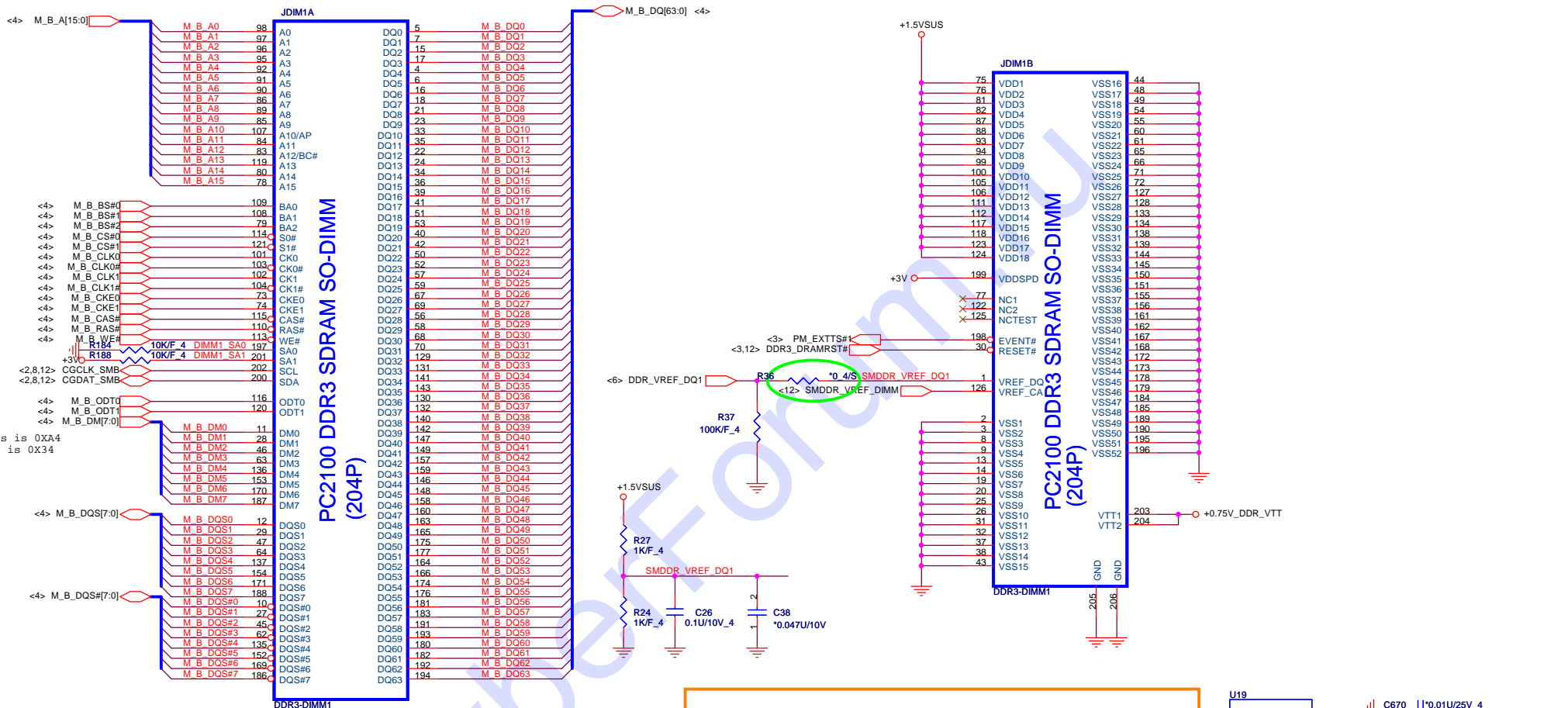

SO-DIMMB SPD Address is 0XA4  
SO-DIMMB TS Address is 0X34

**Place these Caps near So-Dimm1.**  
Some Projects replace 10UF 0805 by 4.7UF 0603  
It can cost down 30%

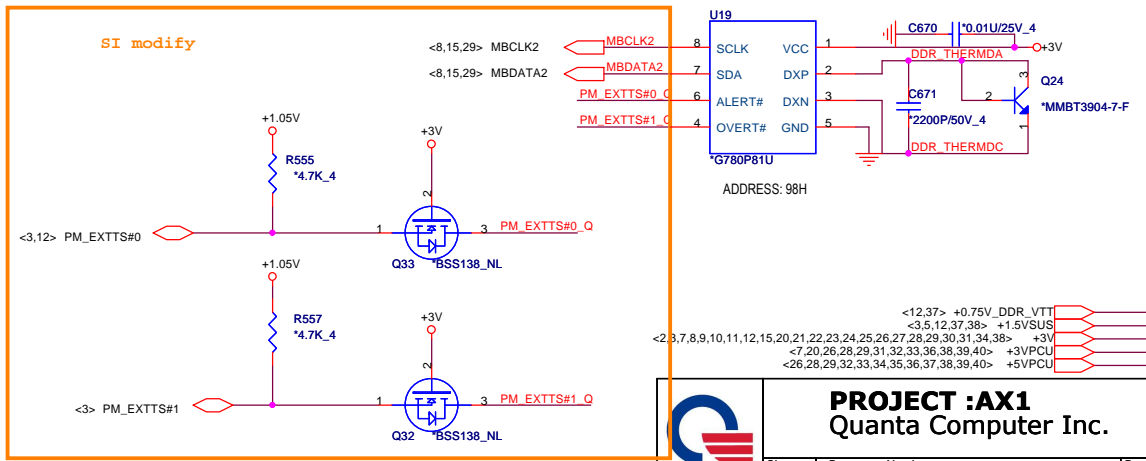
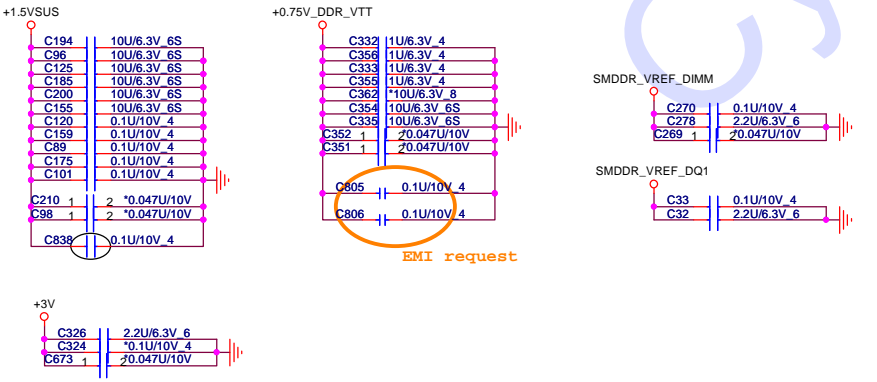

**PROJECT :AX1**  
**Quanta Computer Inc.**

Size Custom	Document Number <b>DDR3 DIMM-1</b>	Rev 1A
Date: Thursday, December 03, 2009   Sheet 13 of 40		



POWER  
+PCIE\_VDDR=1.2V  
+VDD\_MEM1.8V=1.8V  
+VGA\_CORE=0.9-1.2V

2.5GT/s bit rate

U17A

U17G

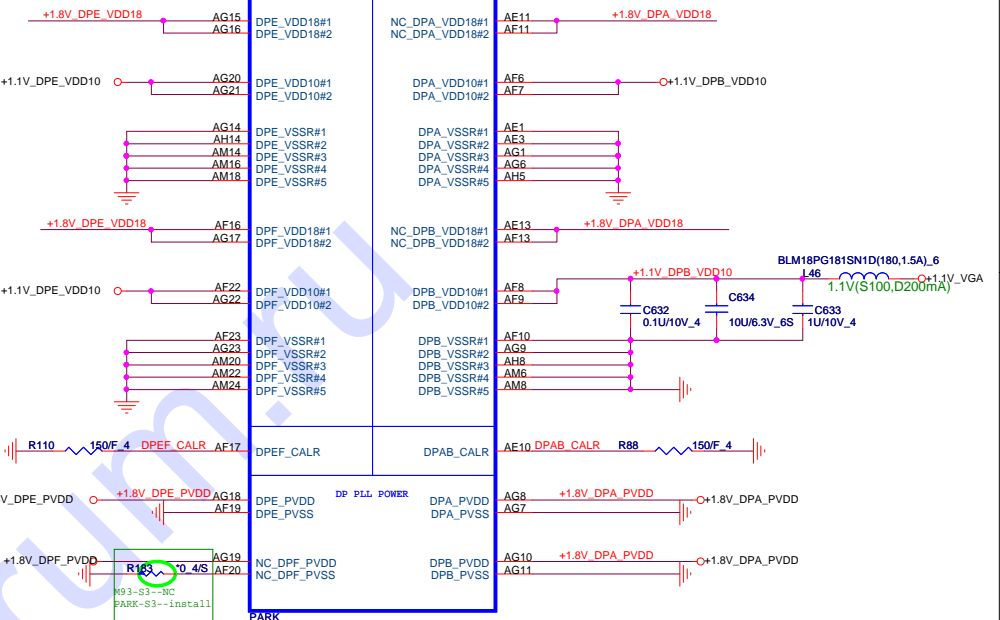

M93-S3--NC PARK-S3--install

10KF 4 1 2 R149

N10 NC\_PWRGOOD

AL27 PERSTB

100MHz (+/-300ppm) input frequency, 0-0.7V single-ended swing

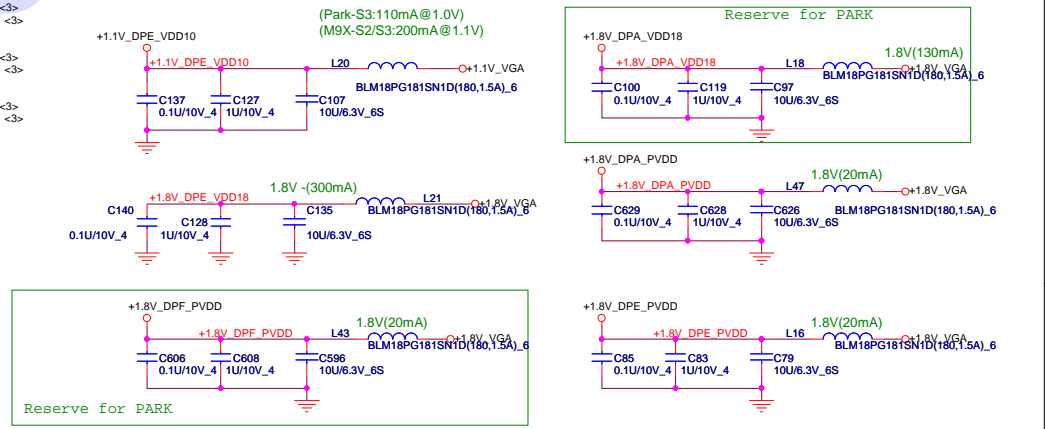
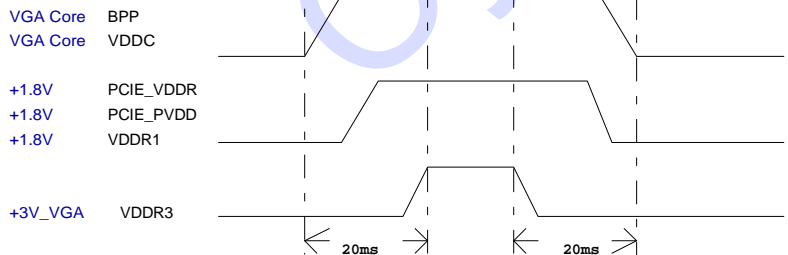

**PROJECT :AX1**  
Quanta Computer Inc.

Size Custom	Document Number M93_PCIE_Interface	Rev 1A
Date: Thursday, November 12, 2009   Sheet 14 of 40		



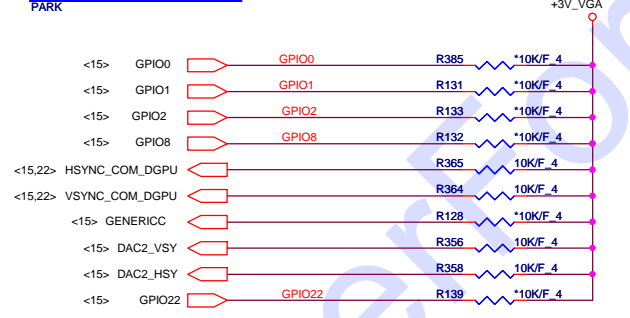
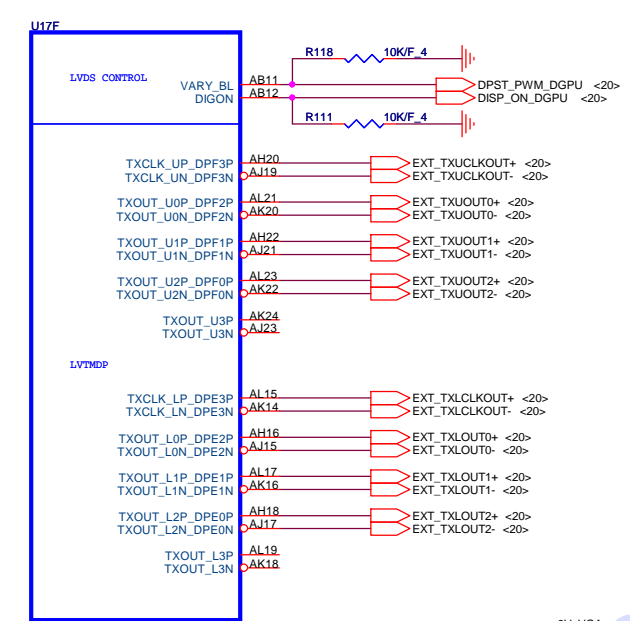
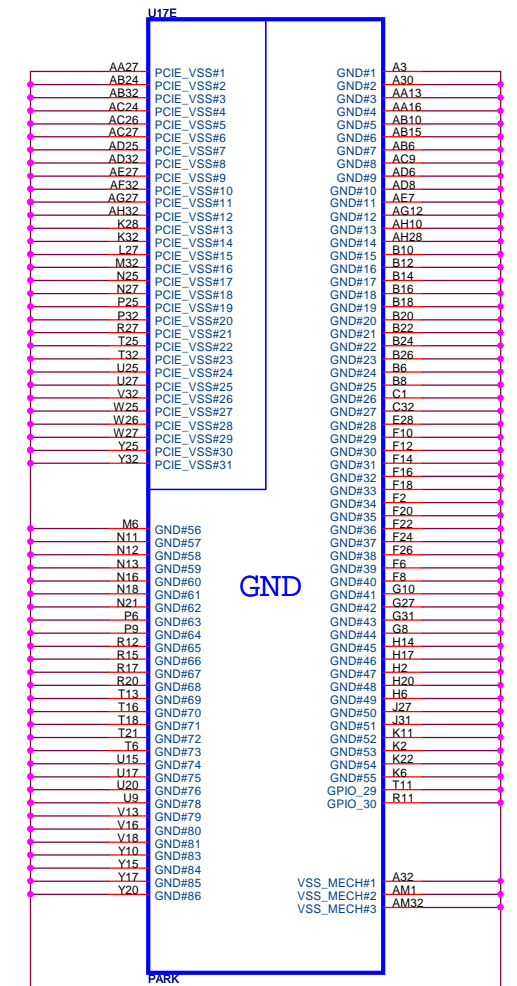

Memory Aperture size

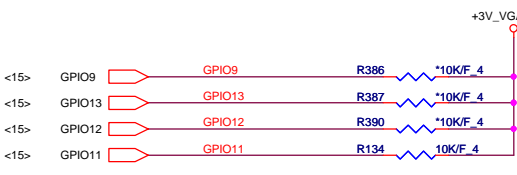

CONFIGURATION STRAPS			
ALLOW FOR PULLUP PADS FOR THESE STRAPS AND IF THESE GPIOs ARE USED, THEY MUST NOT CONFLICT DURING RESET			
STRAPS	PIN	DESCRIPTION OF DEFAULT SETTINGS	RECOMMENDED SETTINGS
TX_PWRS_ENB	GPIO0	<b>Transmitter Power Savings Enable</b> 0: 50% Tx output swing for mobile mode 1: Full Tx output swing (Default setting for Desktop)	1
TX_DEEMPH_EN	GPIO1	<b>PCI Express Transmitter De-emphasis Enable</b> 0: Tx de-emphasis disabled for mobile mode 1: Tx de-emphasis enabled (Default setting for Desktop)	1
BIF_GEN2_EN_A	GPIO2	Enable CLKREQ# Power Management 0 - CLKREQ# power management capability is disabled 1 - CLKREQ# power management capability is enabled	0
RSVD BIF_VGA_DIS RSVD	GPIO8 GPIO9 GPIO21	VGA ENABLED	0 0 0
BIOS_ROM_EN	GPIO_22_ROMCSB	ENABLE EXTERNAL BIOS ROM	0
ROMIDCFG(2,0)	GPIO[13:11]	SERIAL ROM TYPE OR MEMORY APERTURE SIZE SELECT	0 0 1
VIP_DEVICE_STRAP_ENA	V2SYNC	IGNORE VIP DEVICE STRAPS	0
RSVD AUD[1] AUD[0]	GENERICC HSYNC VSYNC	AUD[1] AUD[0] 0 0 No audio function 0 1 Audio for DisplayPort and HDMI if dongle is detected 1 0 Audio for DisplayPort only 1 1 Audio for both DisplayPort and HDMI	0 0 11

AMD RESERVED CONFIGURATION STRAPS			
ALLOW FOR PULLUP PADS FOR THESE STRAPS AND IF THESE GPIOs ARE USED, THEY MUST NOT CONFLICT DURING RESET			
H2SYNC	GENERICC		
PULLUP PADS ARE NOT REQUIRED FOR THESE STRAPS BUT IF THESE GPIOs ARE USED, THEY MUST NOT CONFLICT DURING RESET			
	GPIO21_BB_EN		

GPIO9		GPIO13	GPIO12	GPIO11
BIOSROM		ROMIDCFG2	ROMIDCFG1	ROMIDCFG0
0	128M	0	0	0
0	256M	0	0	1
0	64M	0	1	0
0	32M	0	1	1
0	512M	1	0	0
0	1G	1	0	1
0	2G	1	1	0
0	4G	1	1	1

It is a shared pin strap with CONFIG[2:0] if BIOS\_ROM\_EN is set to 0.

**PROJECT :AX1**  
Quanta Computer Inc.

Size Custom	Document Number <b>M93_GND / LVDS / Straps</b>	Rev 1A
Date: Thursday, November 12, 2009		Sheet 16 of 40

VDD\_CT -- Level translation between core and I/O, excluding memory receivers. 1.8 V ± 5%

PCIE\_VDDR--PCI-E I/O power. 1.8 V ± 5%

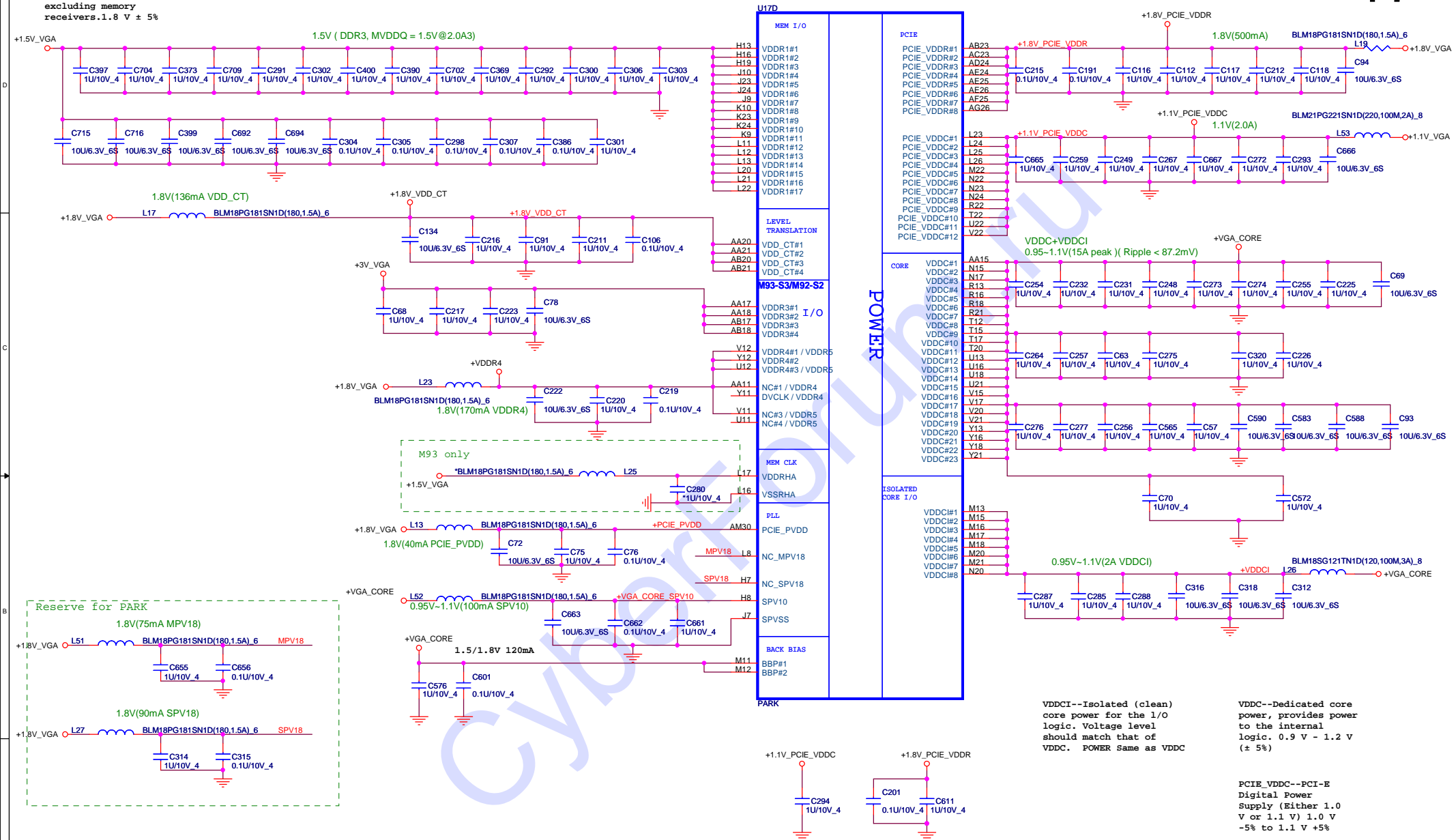

VDDCI--Isolated (clean) core power for the I/O logic. Voltage level should match that of VDDC. POWER Same as VDDC

VDDC--Dedicated core power, provides power to the internal logic. 0.9 V - 1.2 V (± 5%)

PCIE\_VDDC--PCI-E Digital Power Supply (Either 1.0 V or 1.1 V) 1.0 V -5% to 1.1 V +5%

	<b>PROJECT :AX1</b>		Rev 1A
	Quanta Computer Inc.		
	Size Custom	Document Number <b>M93_Power_and_NC</b>	

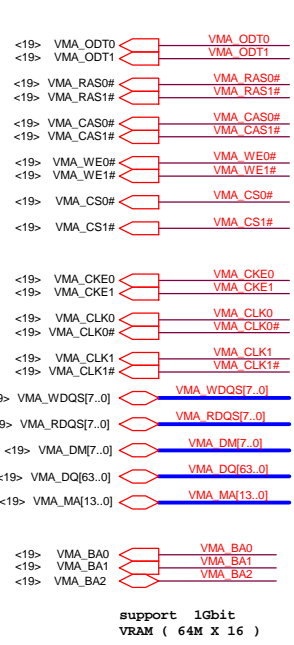

support 1gbit  
VRAM ( 64M X 16 )

DIVIDER RESISTORS	DDR2/DDR3	GDDR3
MVREF TO 1.8V (Rd)	40.2R	40.2R
MVREF TO GND (Re)	100R	100R

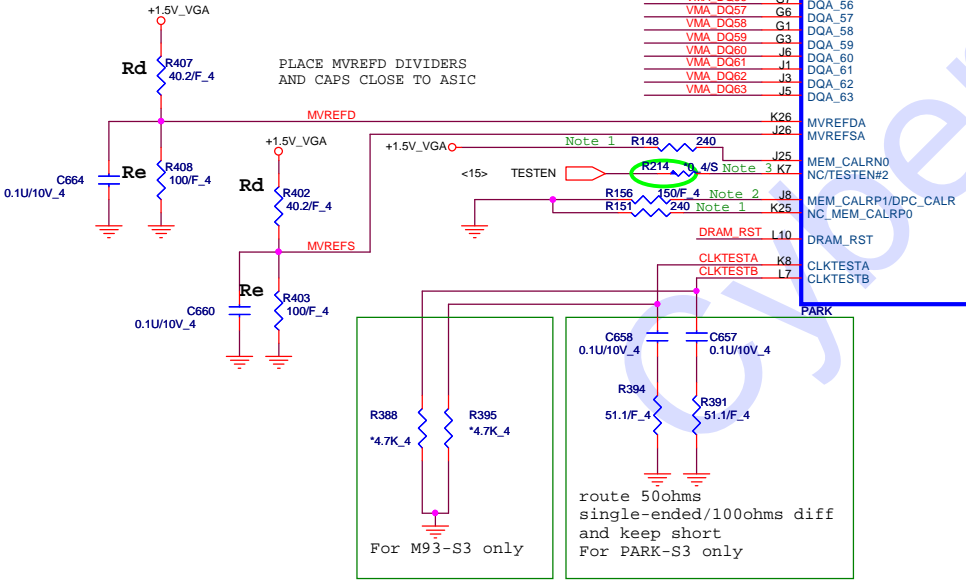

Note 1 :Do not Install for M9X-S2/S3, Install 240 Ohms 0.5% Resistor for PARK-S3.  
 Note 2 :For M9X-S2/S3,J8 Pin Connect to VSS through 240 Ohms(0.5%) resistor.  
 For Park-S3,J8 Pin Connect to VSS through 150 Ohms(1%) resistor for DPC\_CALR  
 Note 3 :For M9X-92/93, K7 Pin (NC\_MEM\_CALRP1) is Not connected.  
 For PARK-S3, K7 Pin (TESTEN#2) connect to TEST\_EN Signal At AF24

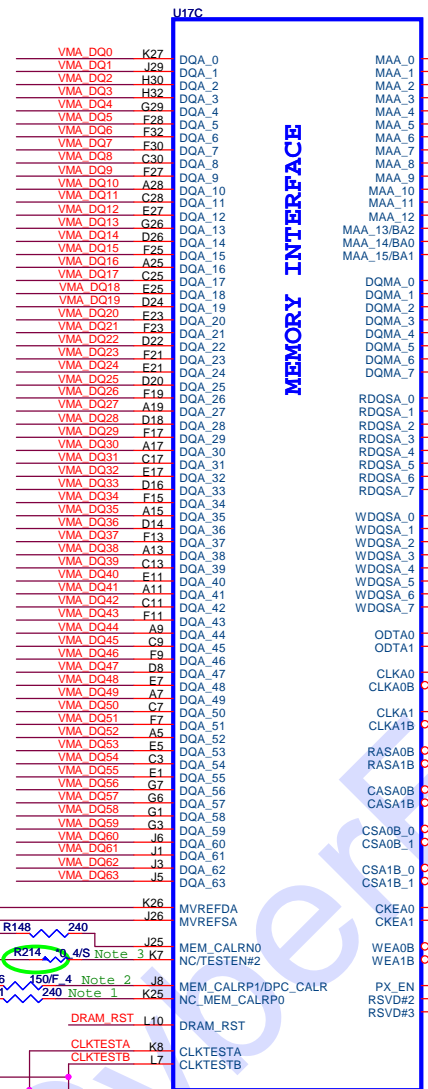

MEMORY INTERFACE

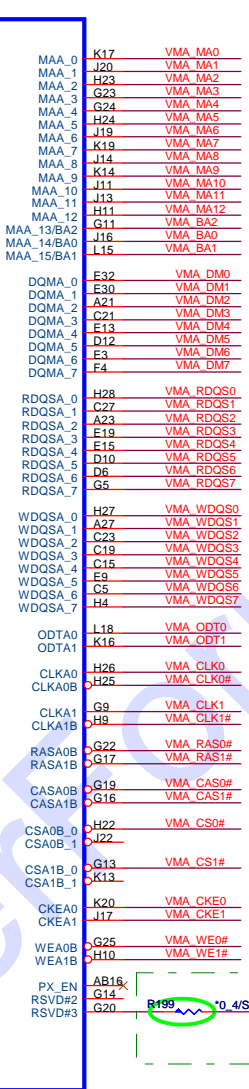

For PARK-S3 only  
For M9X-S2/S3 with DDR3: this pin is not in use.

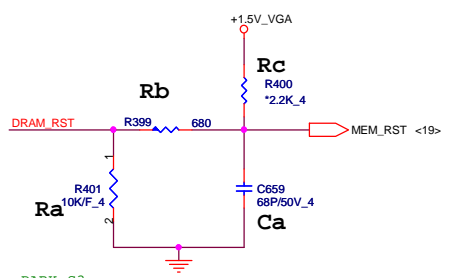

Designator	M9X-S2 and M93-S3	Park-S3
Ra	NC	10K
Rb	0R/Short	680R
Rc	2.2K	NC
Ca	2.2nF	68pF



PROJECT :AX1  
Quanta Computer Inc.



# 512MB DDR3

<18> VMA\_MA[13..0] VMA\_MA[13..0] <18> VMA\_DO[63..0] <18> VMA\_WDQS[7..0]  
 <18> VMA\_DM[7..0] <18> VMA\_WDQS[7..0]

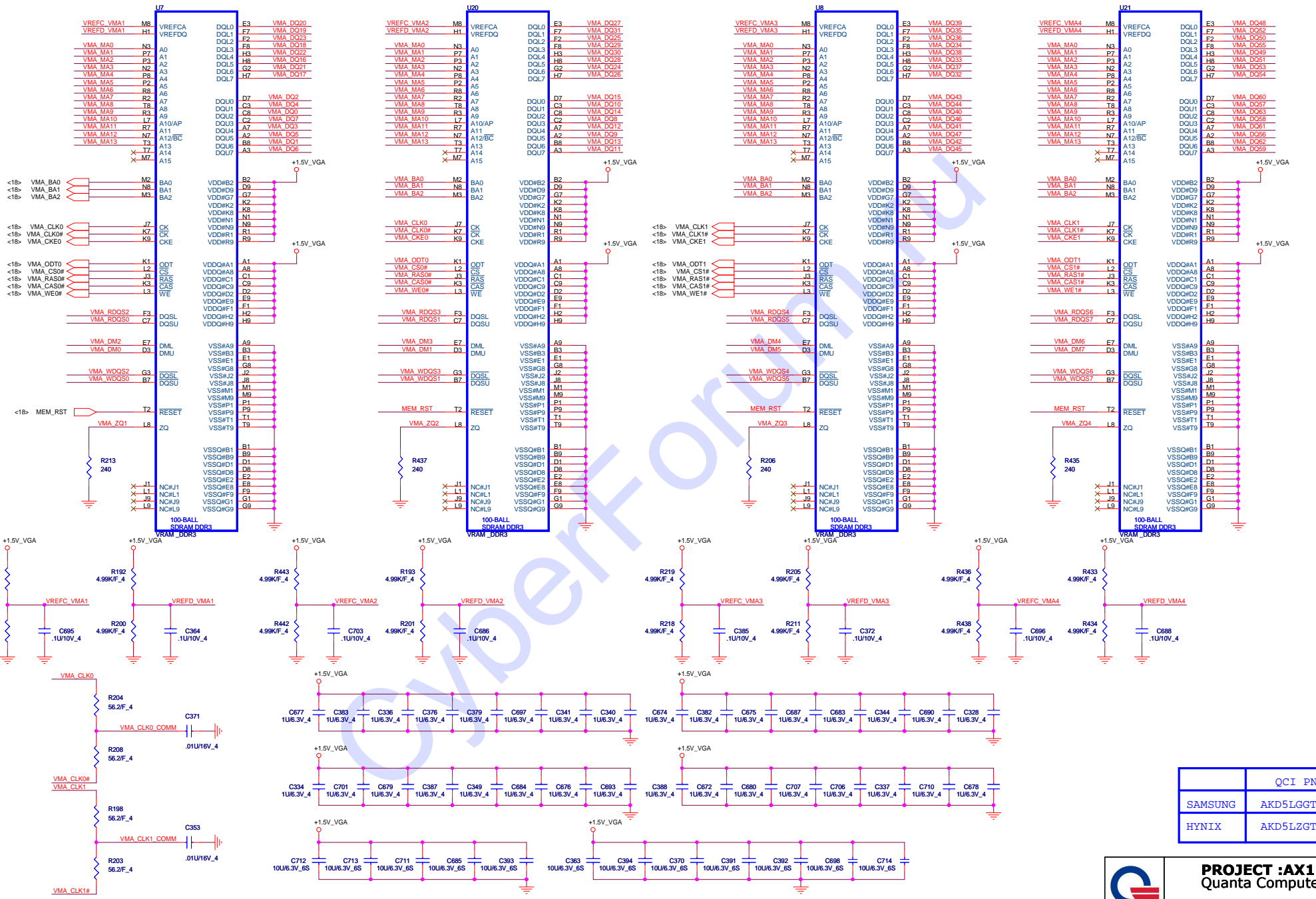

	QCI PN
SAMSUNG	AKD5LGGT502
HYNIX	AKD5LZGTW00

**PROJECT :AX1**  
 Quanta Computer Inc.

Size Custom	Document Number M93/VRAM_A0,A1	Rev 1A
Date: Thursday, November 12, 2009   Sheet 19 of 40		

# LID Switch

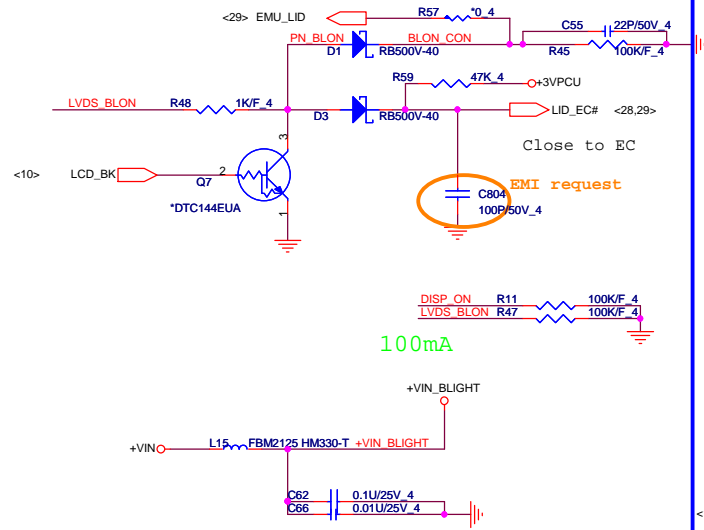

# CAMERA

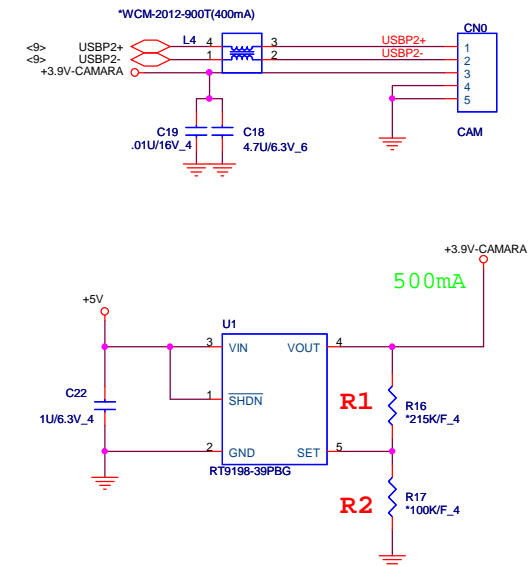

1. If LCD connector near GPU, then place these series Resistors near GPU
2. If LCD connector near PCH, then place these series Resistors near PCH

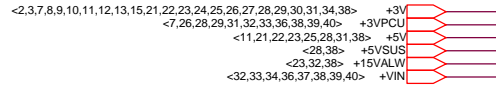
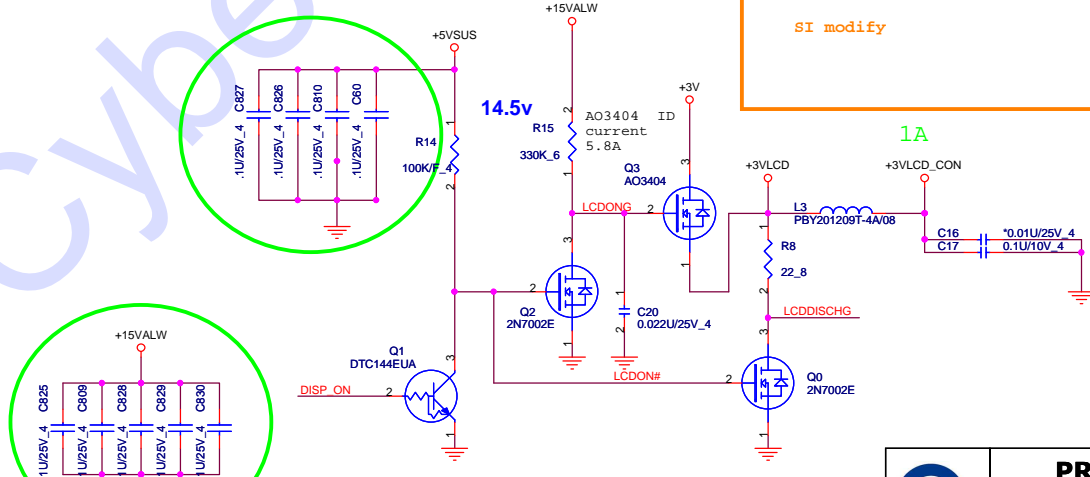
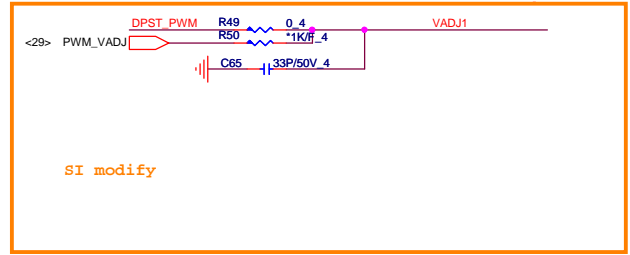
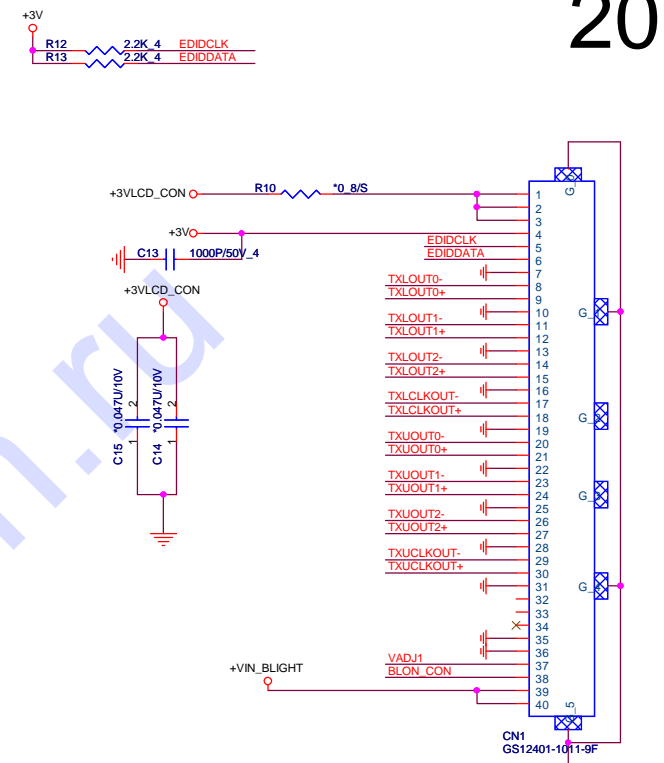
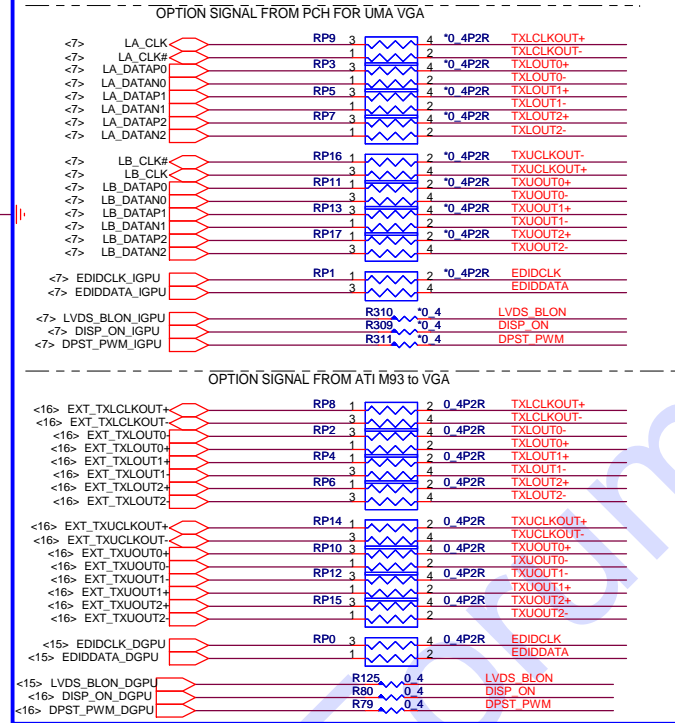

PROJECT :AX1  
Quanta Computer Inc.

Signals		PDT	CHR	PIM
PC1	Ra	NC	NC	NC
HDMI_CFG0	Rb	NC	NC	NC
HDMI_CFG1	Rc	4.7K	NC	NC
REXT	Rd	499	1.2K	4.7K
PC1	Re	NC	4.7K	4.7K
HDMI_OE#	Rf	NC	4.7K	NC
PC0	Rg	4.7K	4.7K	4.7K

9/16 : PIM: need use ALP411LS000 or ALP411LS004 for capella  
 CHR : need Na R1182, add R1027 for capella

Vendor:PDT P/N:AL008101000  
 Vendor:CHR P/N:AL007318002  
 Vendor:PIM P/N:ALP411LS004

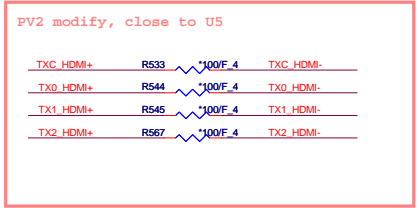
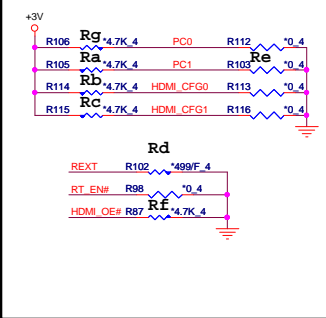

**EQUALIZATION SETTING**  
 PC1:PC0=0:0 8dB  
 PC1:PC0=0:1 4dB Recommended  
 PC1:PC0=1:0 12dB  
 PC1:PC0=1:1 0dB

**SCLZ/SDAZ Low-level input/output Voltage**  
 CFG1:CFG0=0:0 VIL:<0.4V VOL:0.6V (Default)  
 CGF1:CGF0=0:1 VIL:<0.36V VOL:0.55V  
 CGF1:CGF0=1:0 VIL:<0.44V VOL:0.65V  
 CGF1:CGF0=1:1 VIL:<0.36V VOL:0.6V

**For UMA HDMI function**

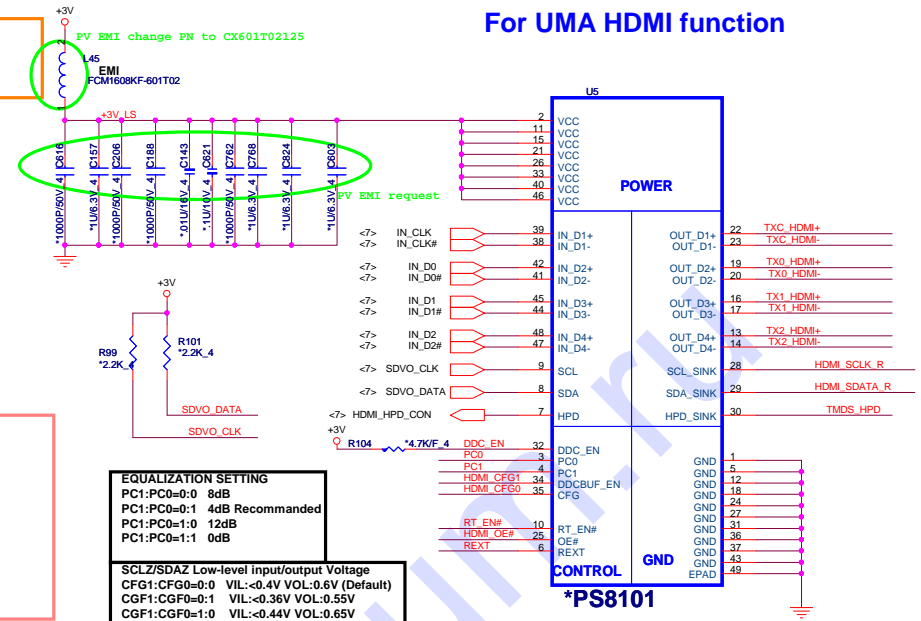

**FOR UMA ONLY FROM LEVEL SHIFTER**

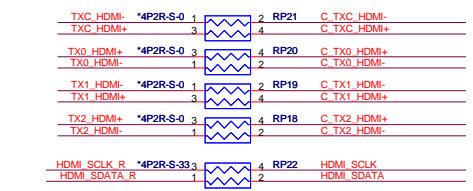

**FOR DISCRETE ONLY FROM M93/PARK**

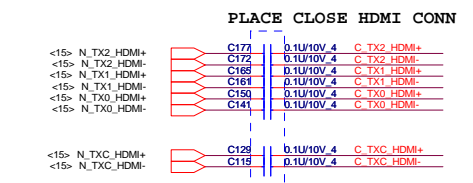

**FOR DISCRETE ONLY**

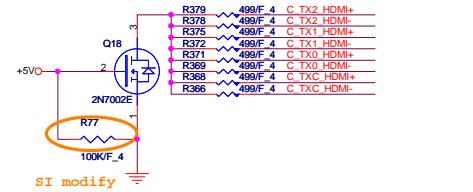

**DISCRETE HDMI I2C SELECT**  
 Close to HDMI Connector

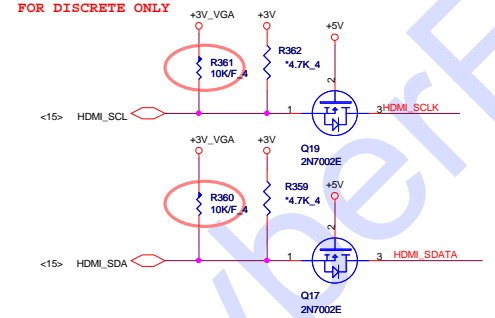

**UMA & DISCRETE HDMI HPD SENSE**

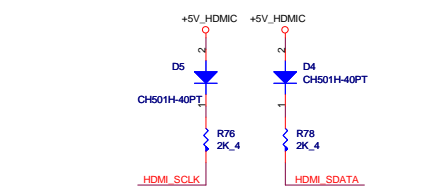
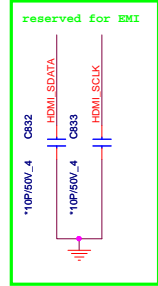
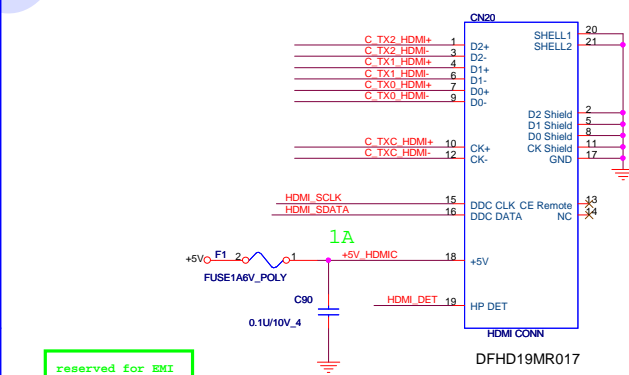
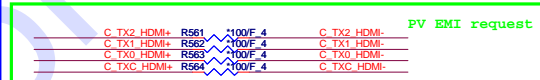
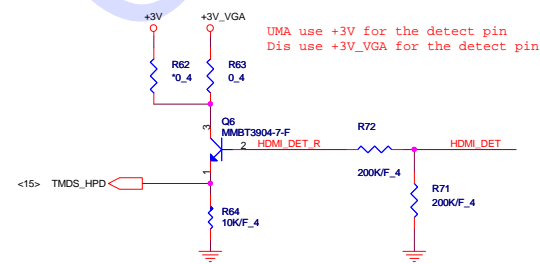

**PROJECT :AX1**  
 Quanta Computer Inc.

Size Custom	Document Number <b>HDMI CONN</b>	Rev 1A
Date: Monday, November 16, 2009		Sheet 21 of 40

# CRT PORT

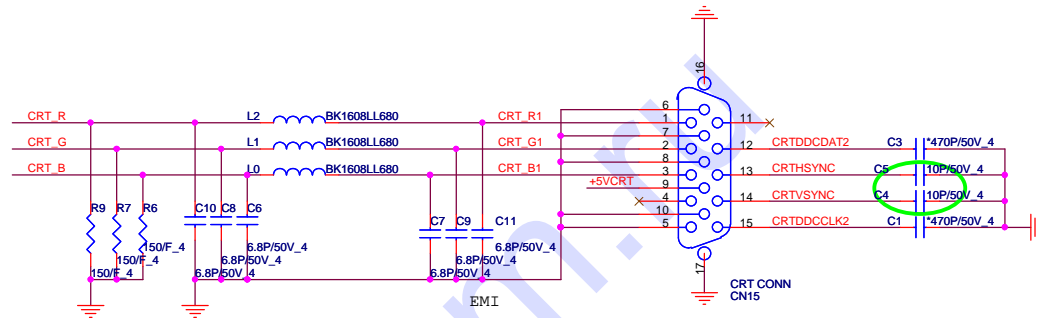
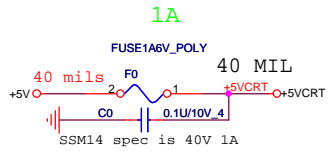

## FOR UMA

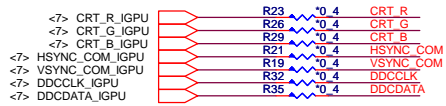

## FOR DISCRETE

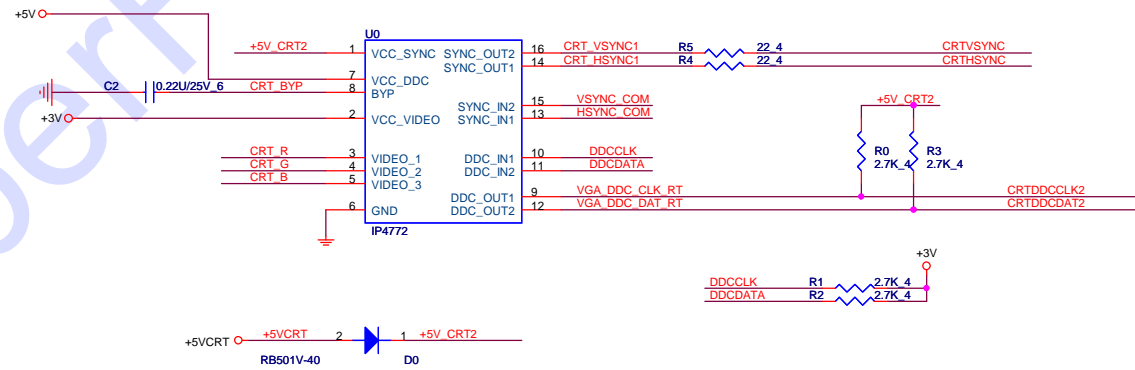
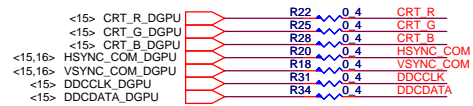

**PROJECT :AX1**  
Quanta Computer Inc.

# CPU FAN

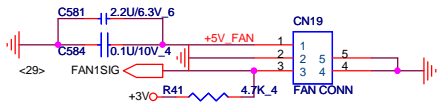

DFHD03MR008

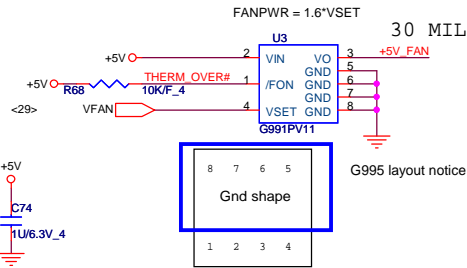

# SATA HDD CONNECTOR

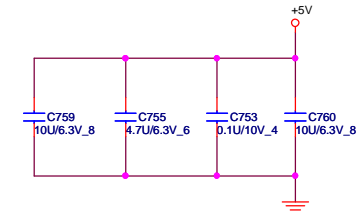
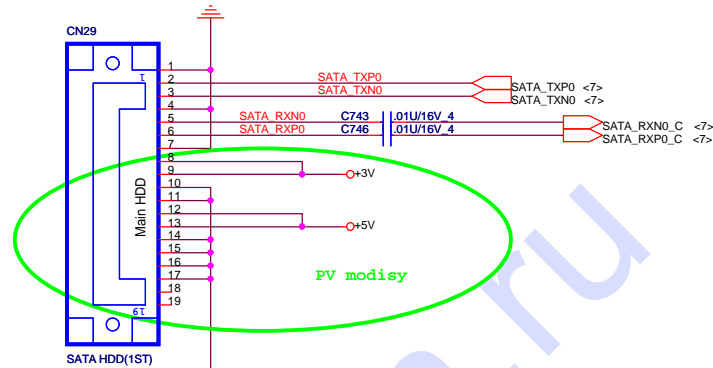

# SATA ODD CONNECTOR

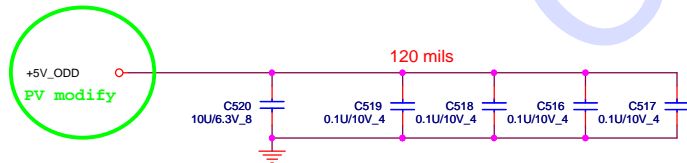
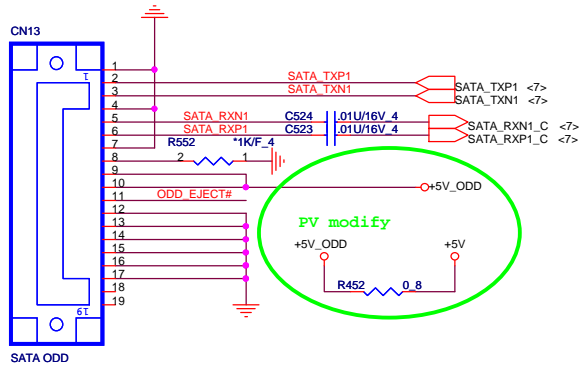

## SI Add

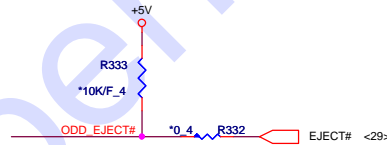

High : ODD power down  
Low : ODD power on

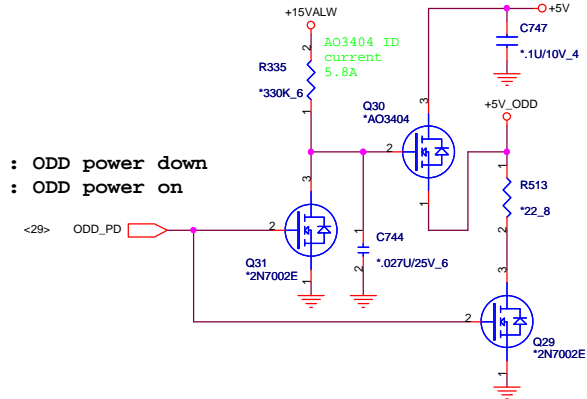

**PROJECT :AX1**  
Quanta Computer Inc.



PU for internal CLK input  
Unstuff for external XTAL(12MHZ)

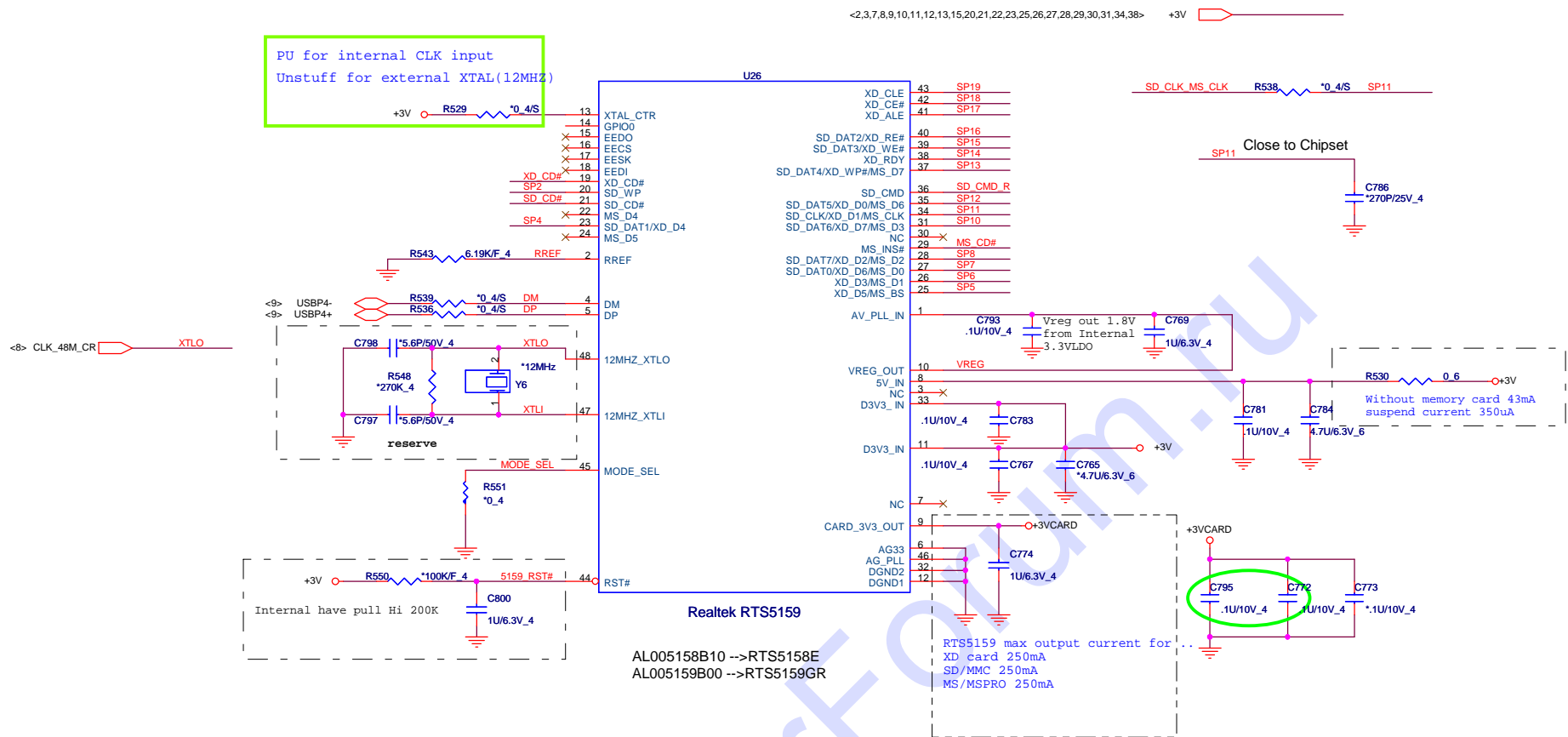

Realtek RTS5159

AL005158B10 -->RTS5158E  
AL005159B00 -->RTS5159GR

RTS5159 max output current for...  
XD card 250mA  
SD/MMC 250mA  
MS/MSPRO 250mA

**Note:**

SP0	MS	XD
SP1		XD_CD#
SP2	SD_WP	
SP3	SD_CD#	
SP4	SD_DAT1	XD D4
SP5		MS BS XD D5
SP6	MS INS#	MS D1 XD D3
SP7	SD_DAT0	MS D0 XD D6
SP8	SD_DAT7	MS D2 XD D2
SP9		MS INS#
SP10	SD_DAT6	MS D3 XD D7
SP11	SD_CLK	MS_SCLK XD D1
SP12	SD_DAT5	XD D0
SP13	SD_DAT4	XD_WP#
SP14		XD R/B#
SP15	SD_DAT3	XD WE#
SP16	SD_DAT2	XD RE#
SP17		XD ALE
SP18		XD CE#
SP19		XD CLE

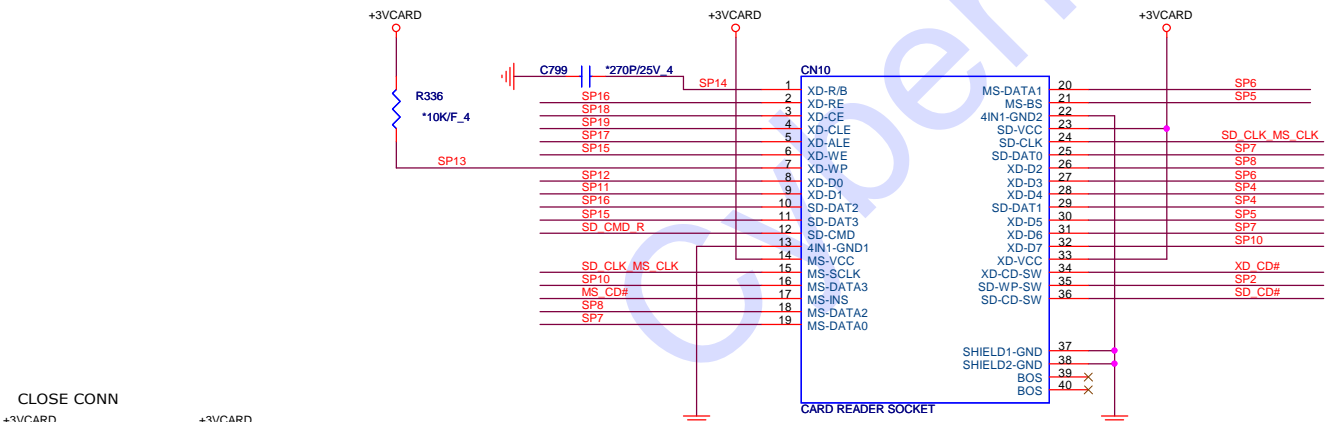

**5 IN1 CARD-READER (PUSH-PUSH)**  
Support SD/SD PRO/MMC/MS/MS PRO/XD Cards

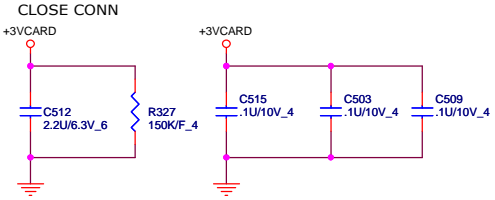

**PROJECT :AX1**  
Quanta Computer Inc.

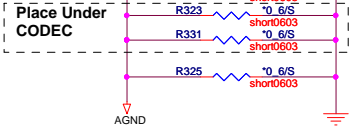
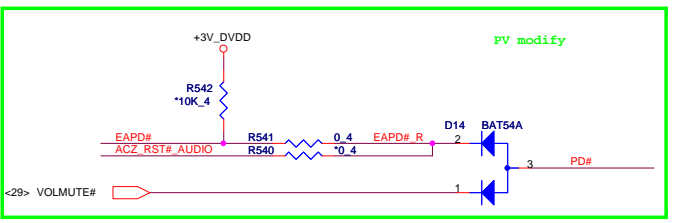
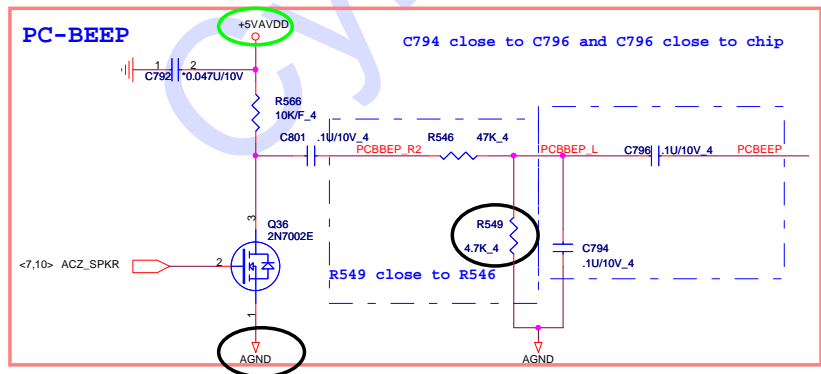
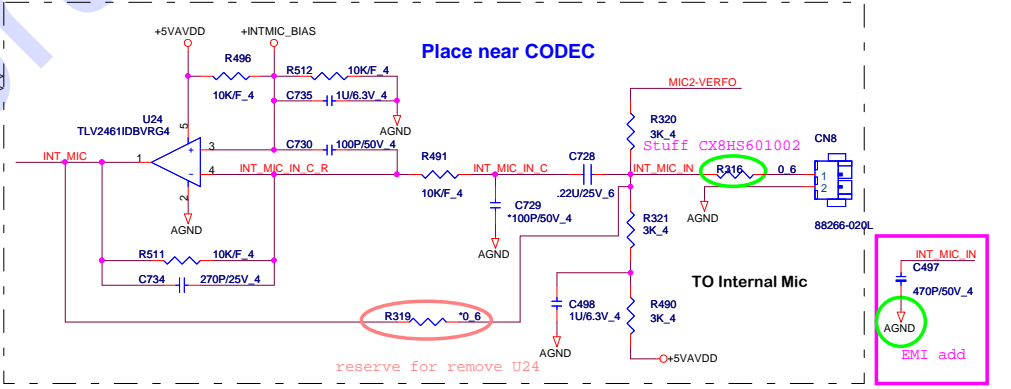
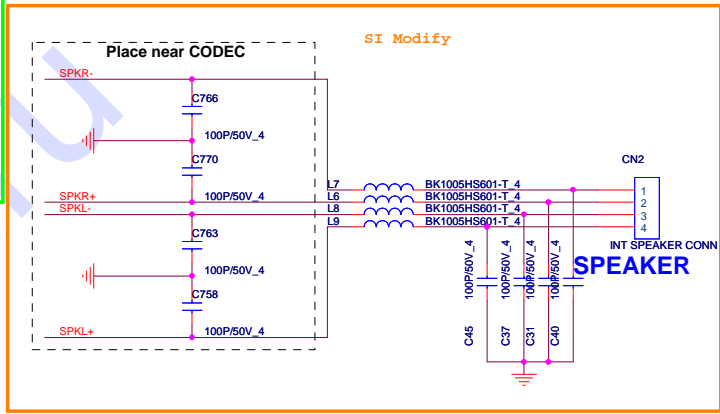
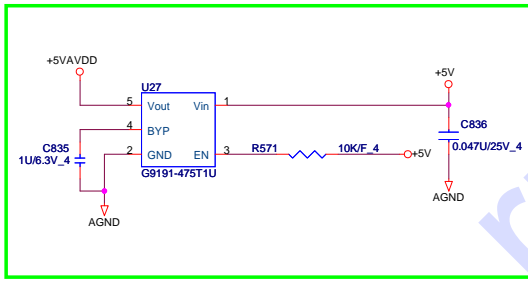
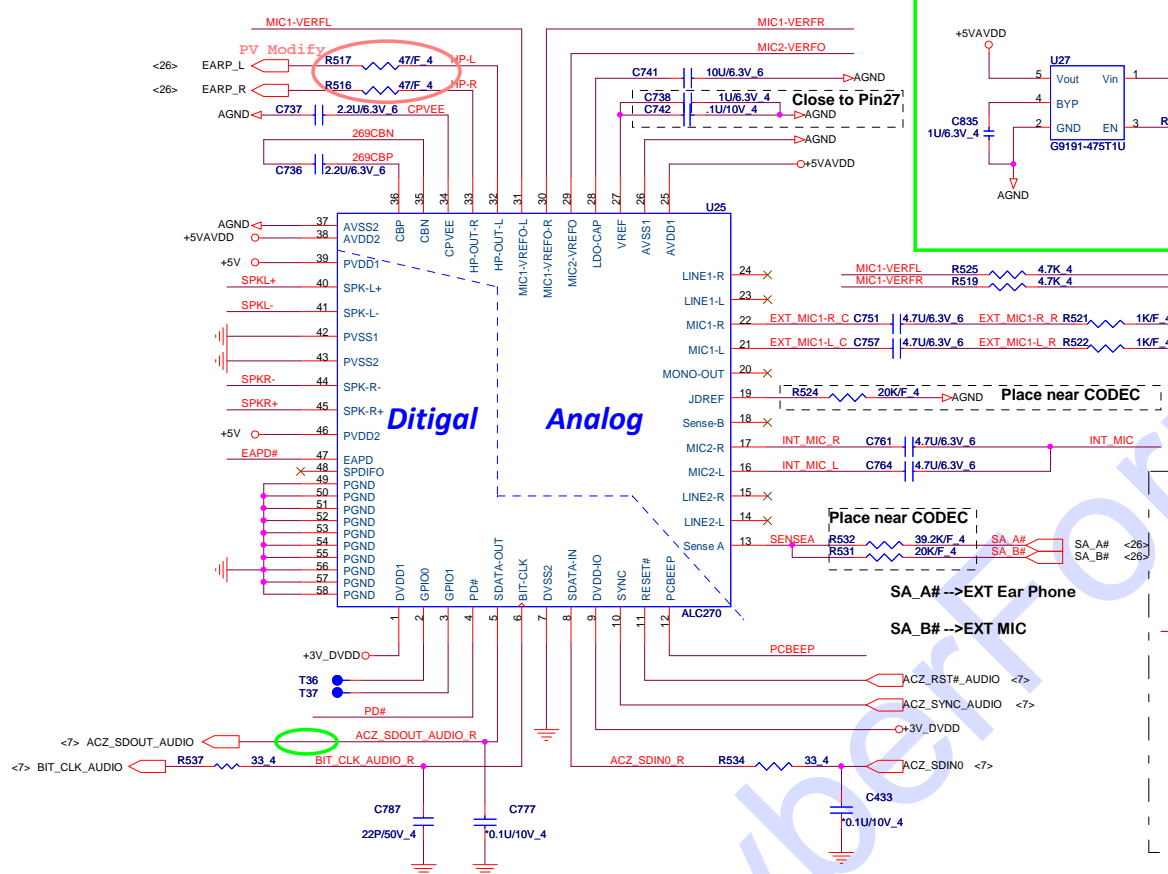
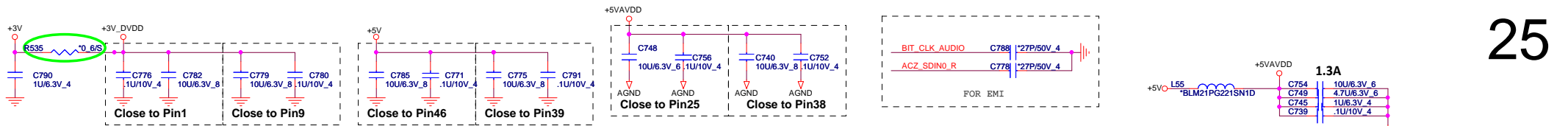

**BLUETOOTH**

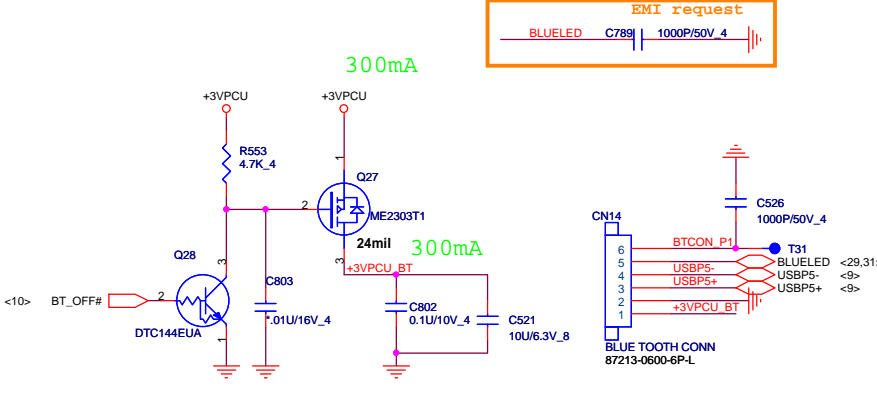

**LEFT SIDE USBX1**

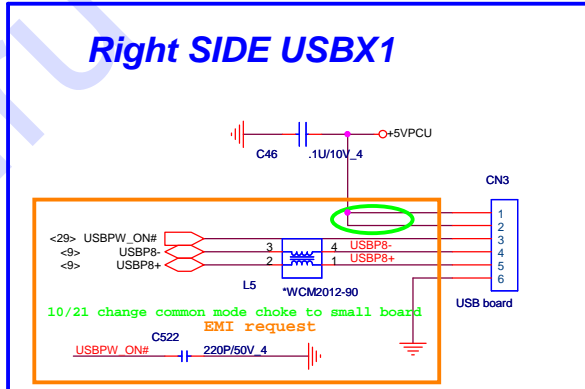
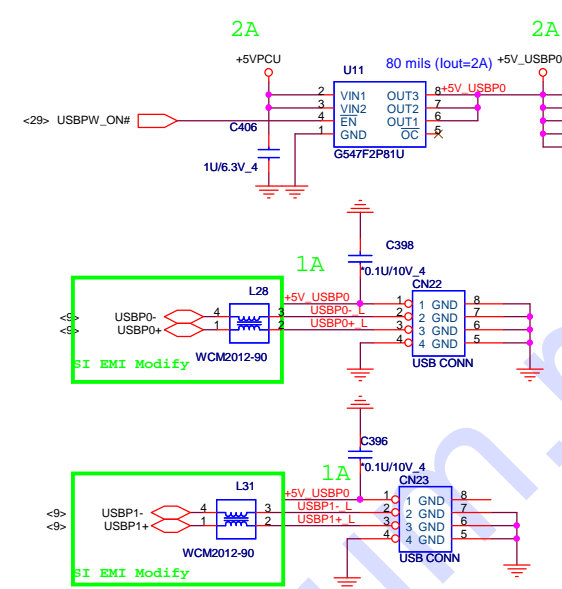

**Modem CONN**

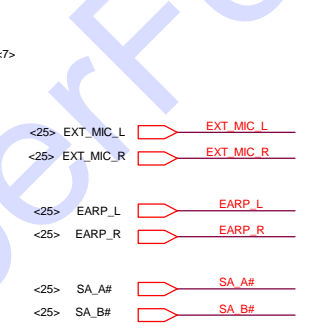
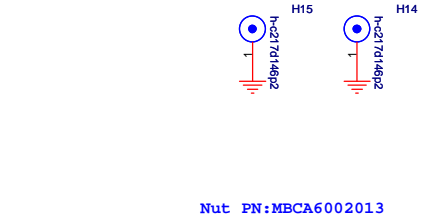
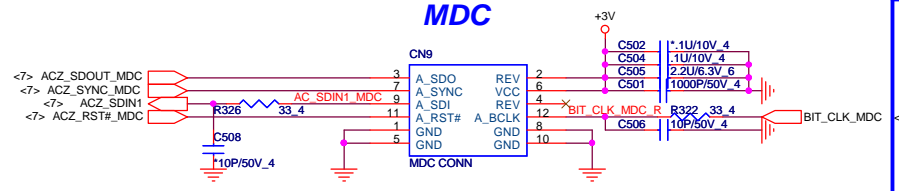

**Line out**

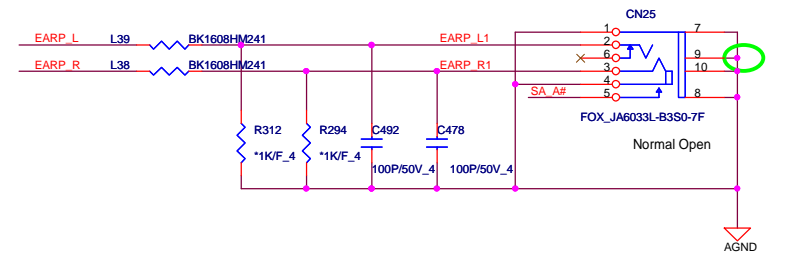

**MIC**

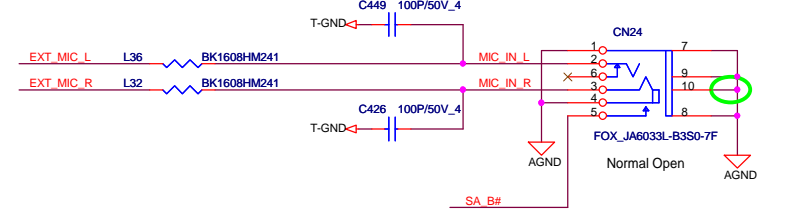

**PROJECT :AX1**  
**Quanta Computer Inc.**

Size Custom	Document Number <b>USB/BT/Modem/Audio Jack</b>	Rev 1A
Date: Monday, November 30, 2009   Sheet 26 of 40		

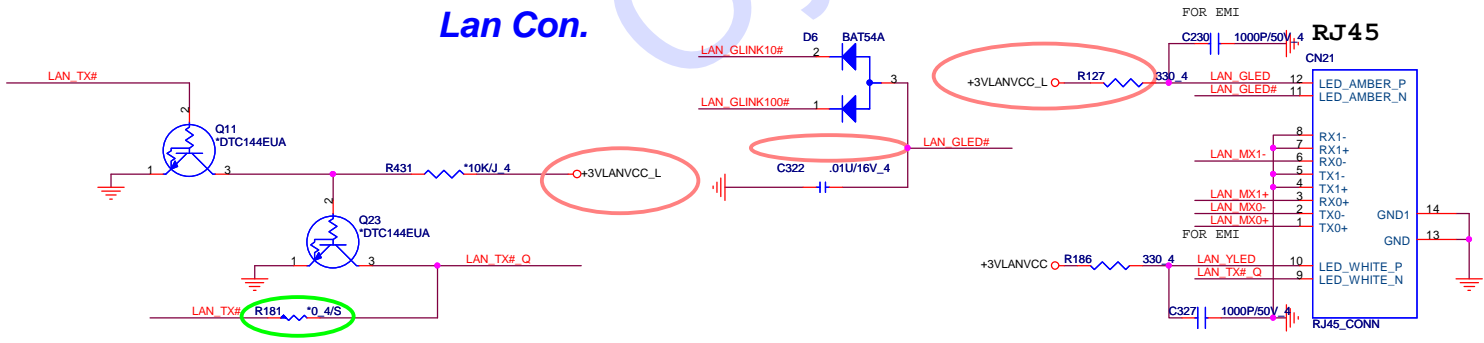
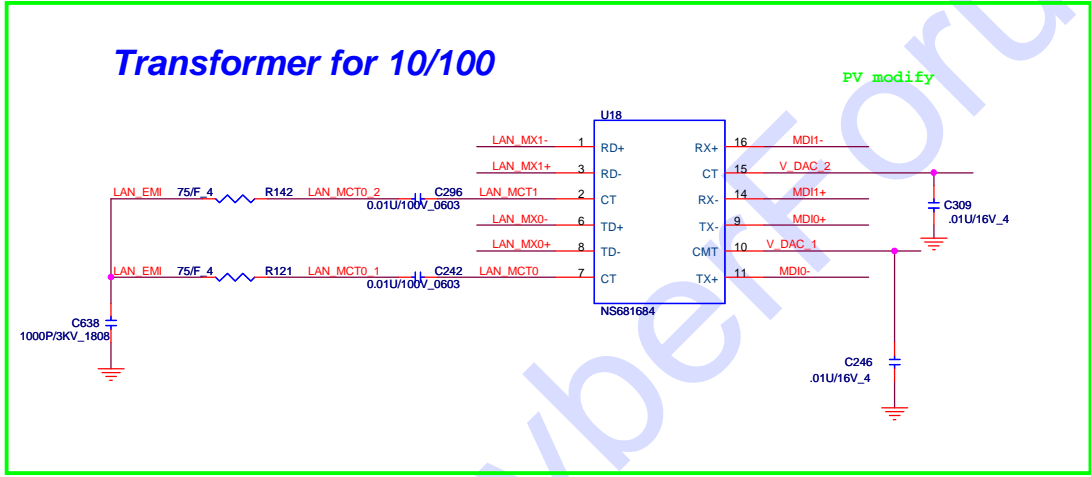
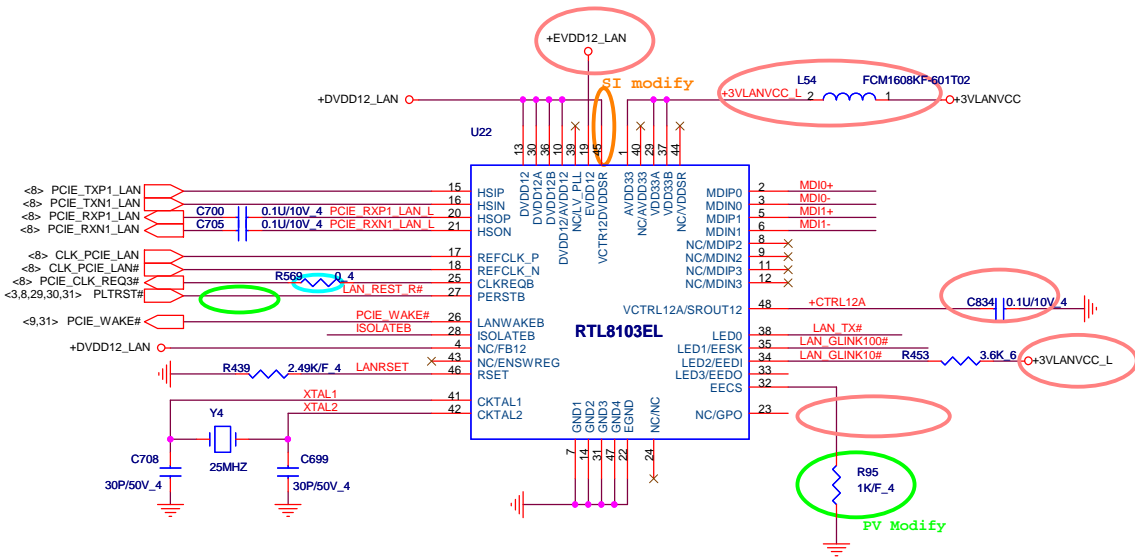

<b>PROJECT :AX1</b> <b>Quanta Computer Inc.</b>		
Size Custom	Document Number <b>RTL811DL/8103EL</b>	Rev 1A
Date: Monday, November 30, 2009   Sheet 27 of 40		

# POWER BOTTON CONNECT

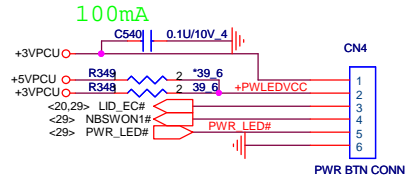

1. +3VPCU(LIDSWITCH PWR)
2. LEDVCC(+3VPCU)
3. LIDSWITCH
4. POWERON#
5. PWRLED#
6. GND

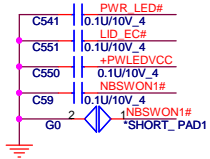

# KEYBOARD Con.

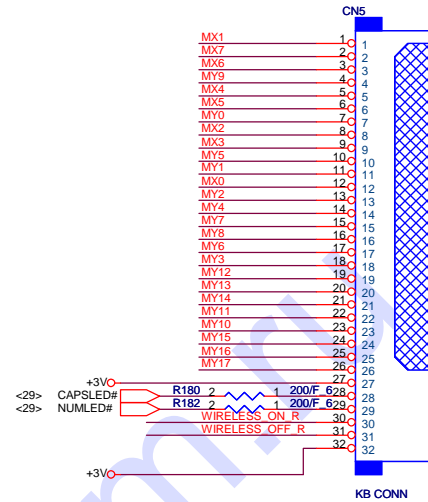
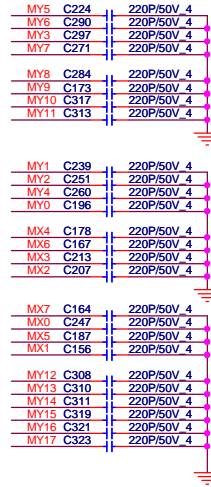

# KEYBOARD PULL-UP

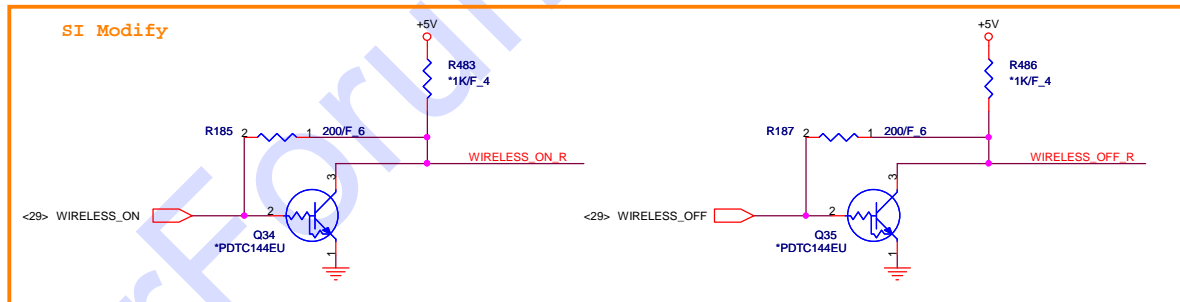
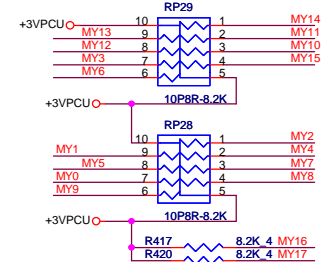

# TOUCH PAD Con.

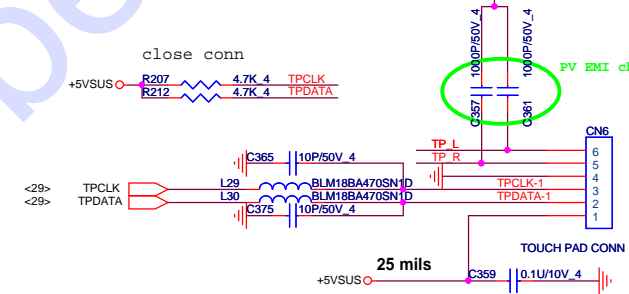

# To TOUCH PAD SW board

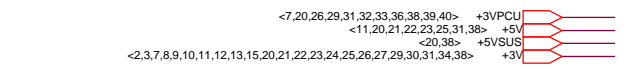
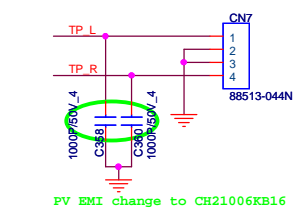



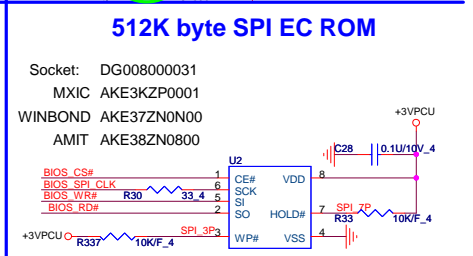
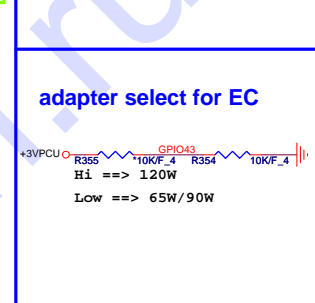
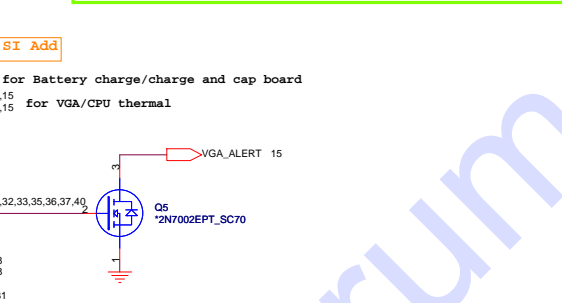
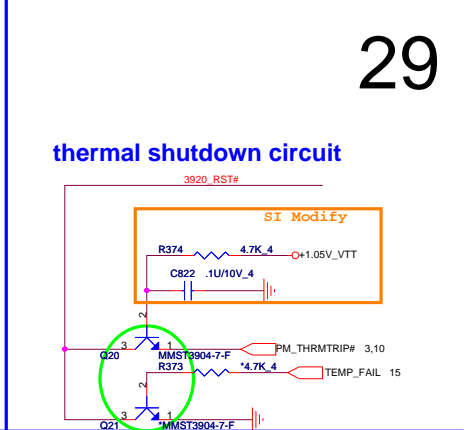
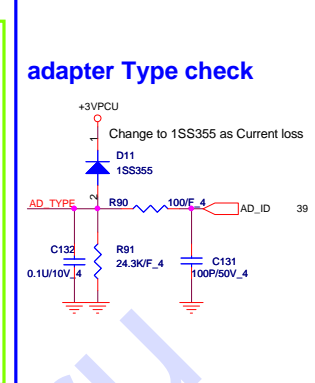
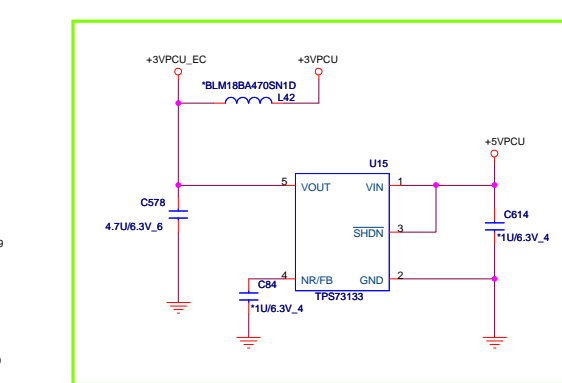
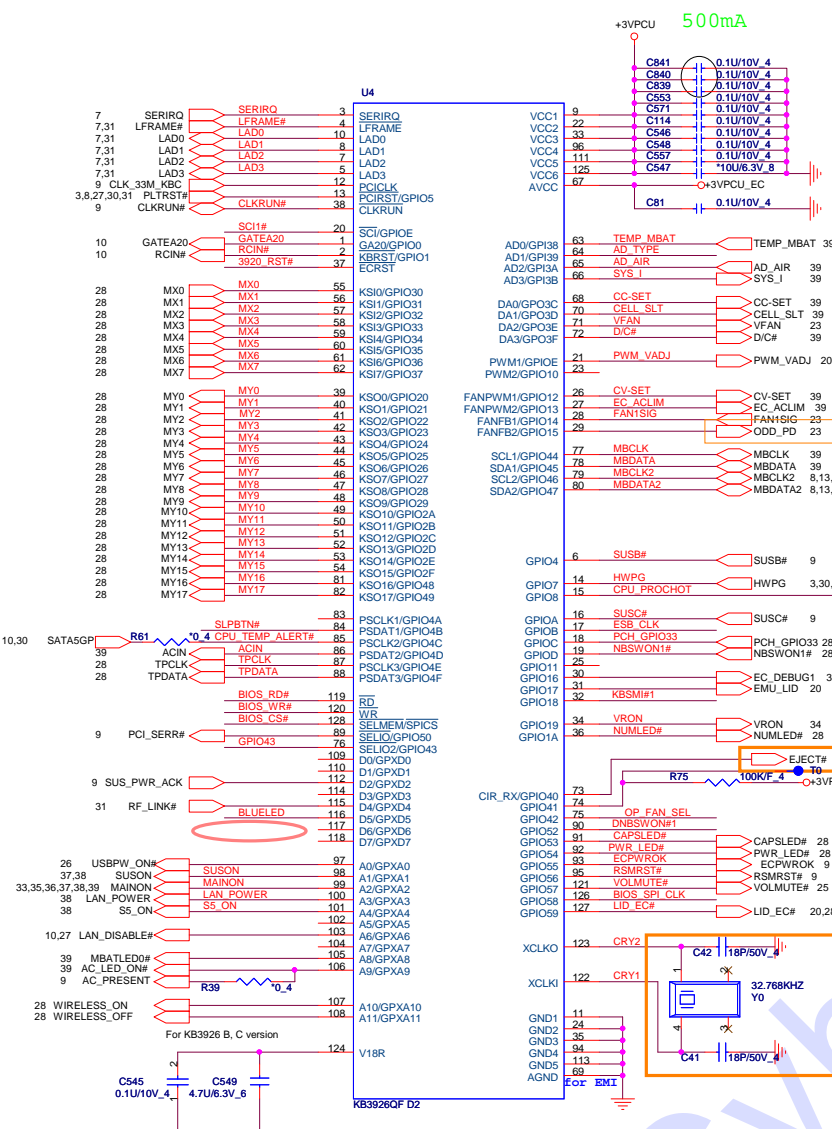

Project Model	GPIO42
AX 14"	High
AX 15.6"	Low
AX 17.3"	Middle (1.5V)

GPIO42 control fan table

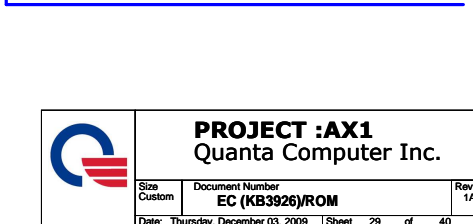
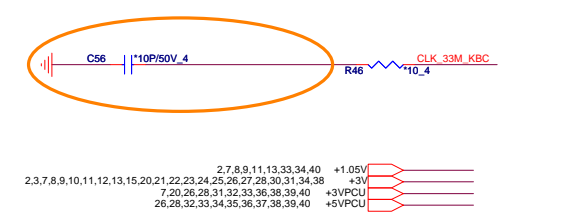
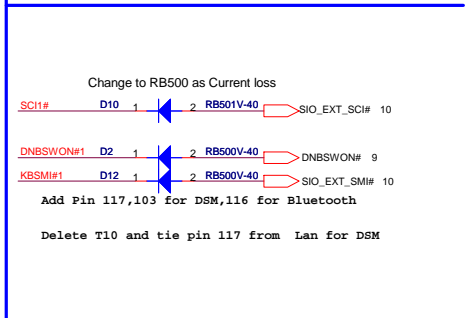
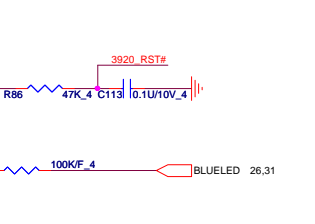
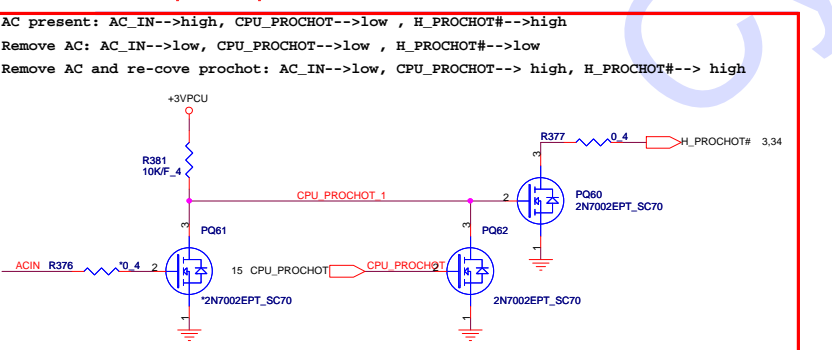
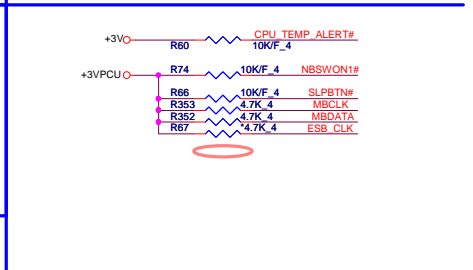
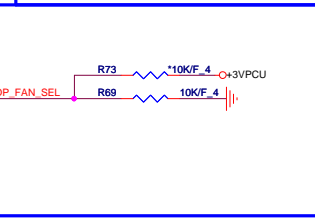

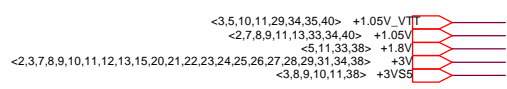
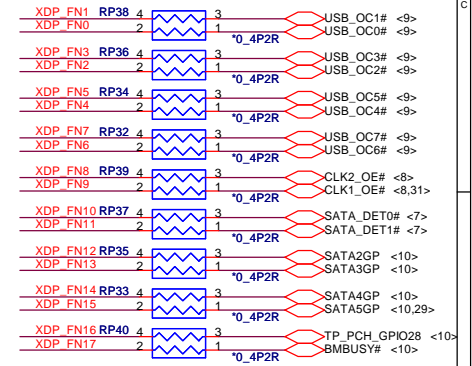
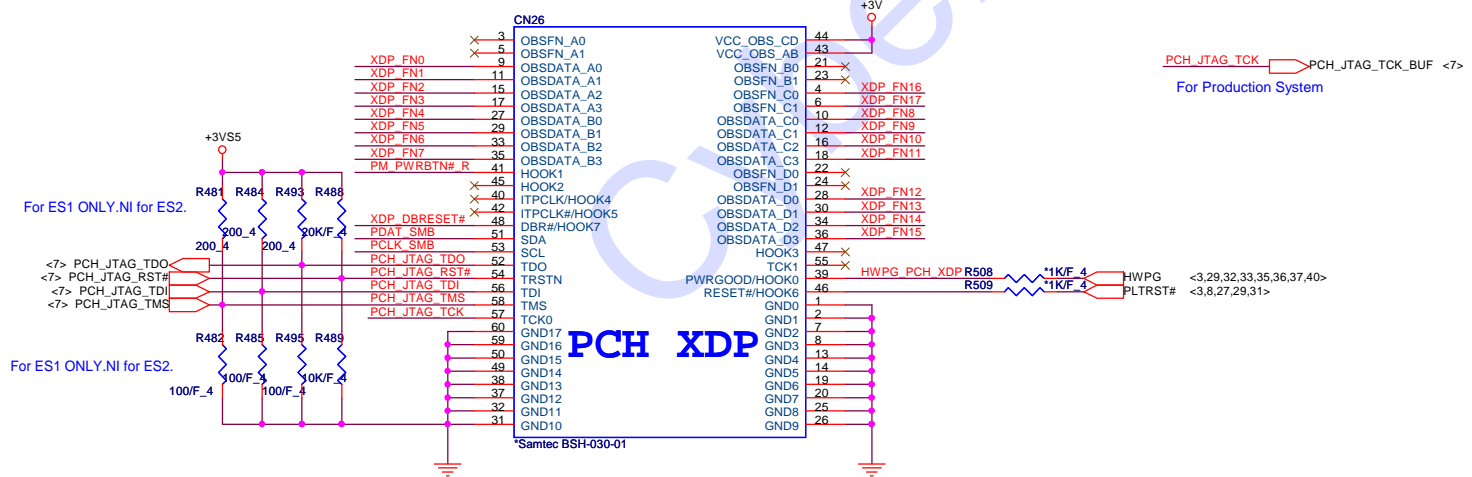
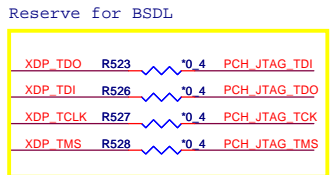
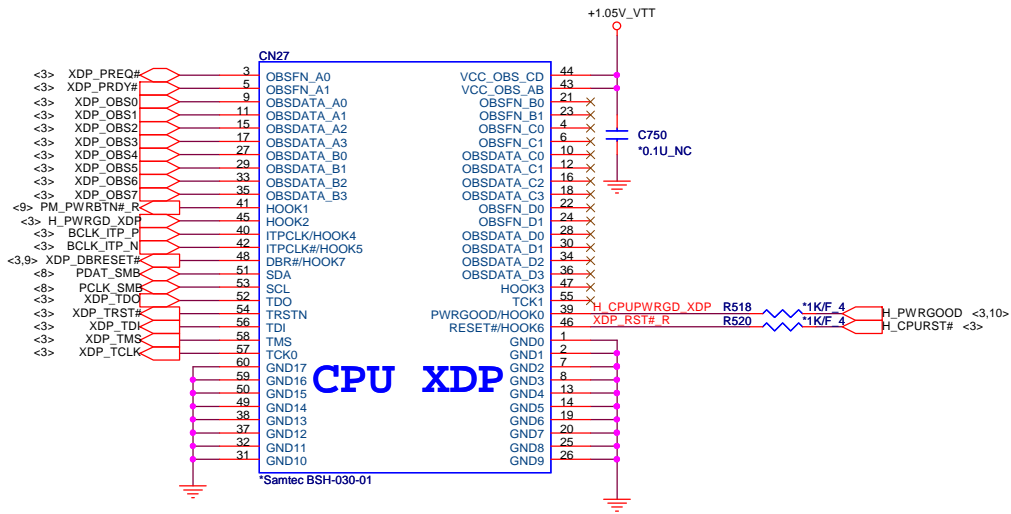

**PROJECT :AX1**  
Quanta Computer Inc.

Size	Document Number	Rev
Custom	<b>XDP/BRAIDWOOD</b>	1A
Date: Thursday, November 12, 2009   Sheet 30 of 40		

# Mini PCI-E Card 1 WLAN

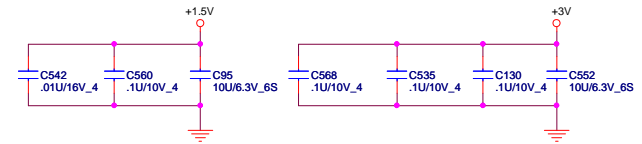
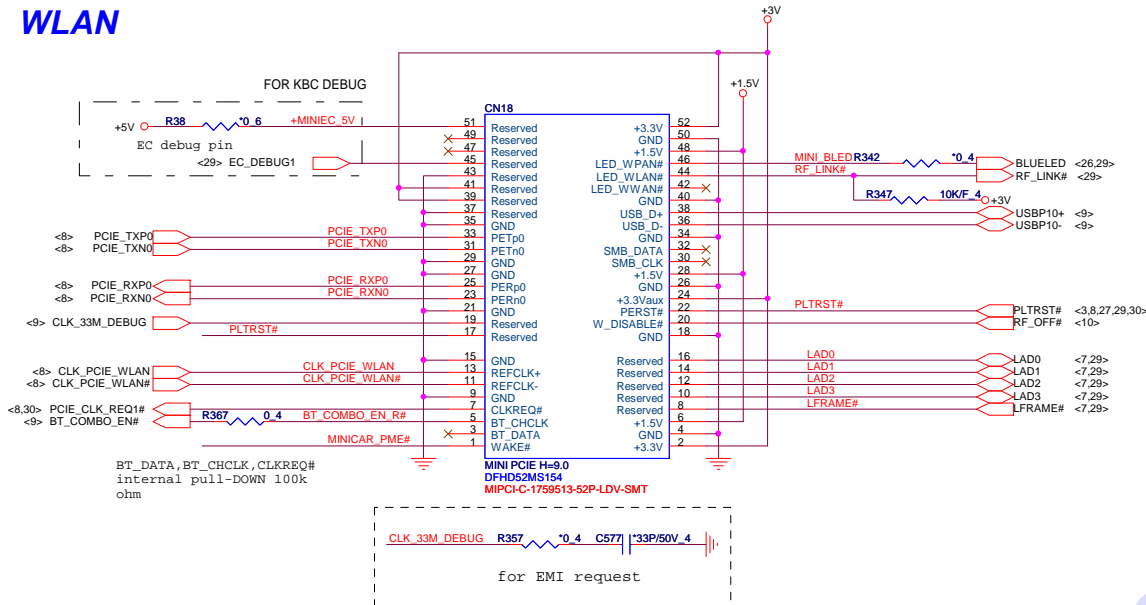

INTEL WLAN CARD PIN 20 W\_DISABLE# have internal pull-up 110k ohm

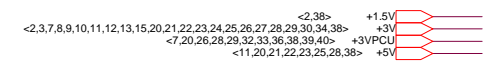
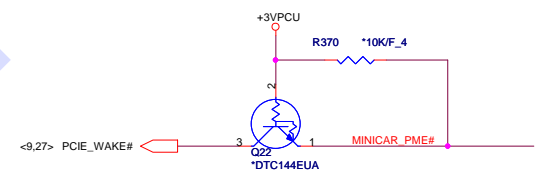

CyberForum.ru

# DC/DC +3V\_ALW/+5V\_ALW/+5V\_ALW2 /+15V\_ALW

+5V +/- 5%  
 Countinue current:6A  
 Peak current :8A  
 OCP minimum :10A

+3.3V +/- 5%  
 Countinue current:5A  
 Peak current:6A  
 OCP minimum 7.5A

Place these CAPS  
 close to FETs

Place these CAPS  
 close to FETs

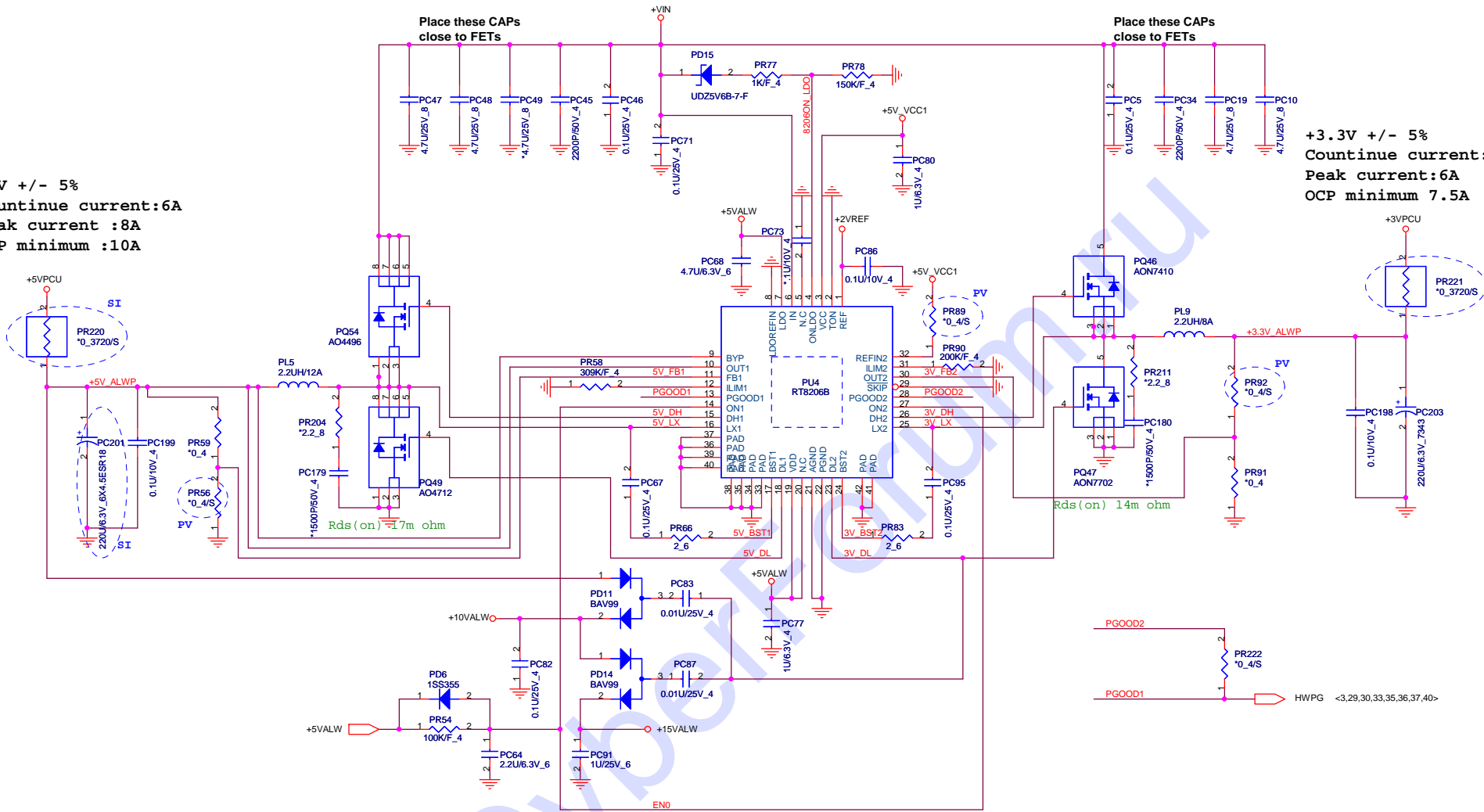

NTC need place under CPU Socket  
 CPU Thermal protection at 90 +/-3 degrec

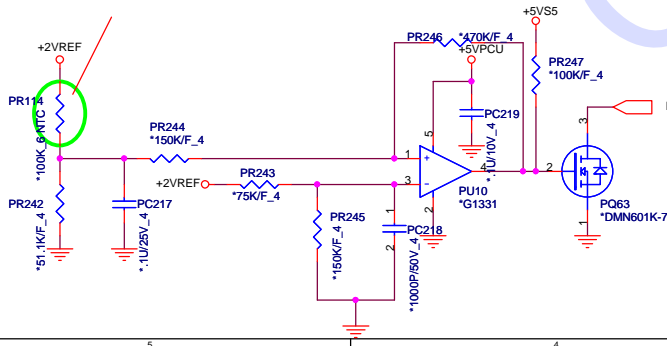

EMI request

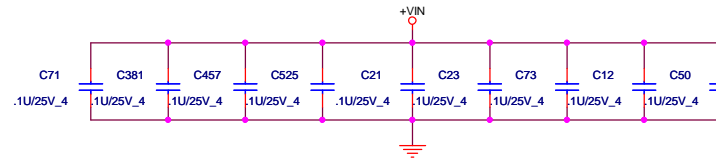

	<b>PROJECT :AX1</b>	
	Quanta Computer Inc.	
Size Custom	Document Number <b>+5V/+3V (RT8206B)</b>	Rev 1A
Date: Thursday, November 12, 2009   Sheet 32 of 40		

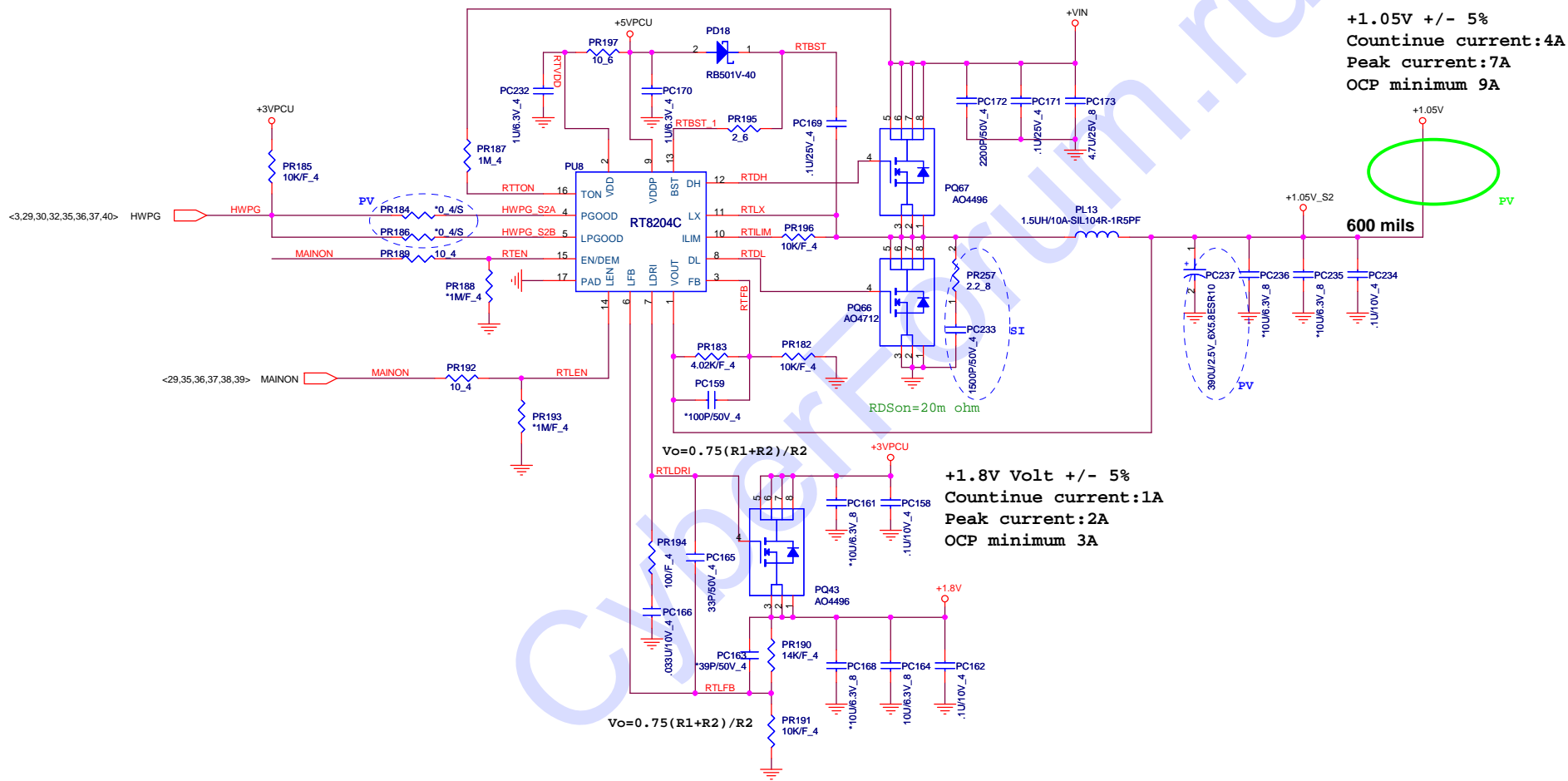



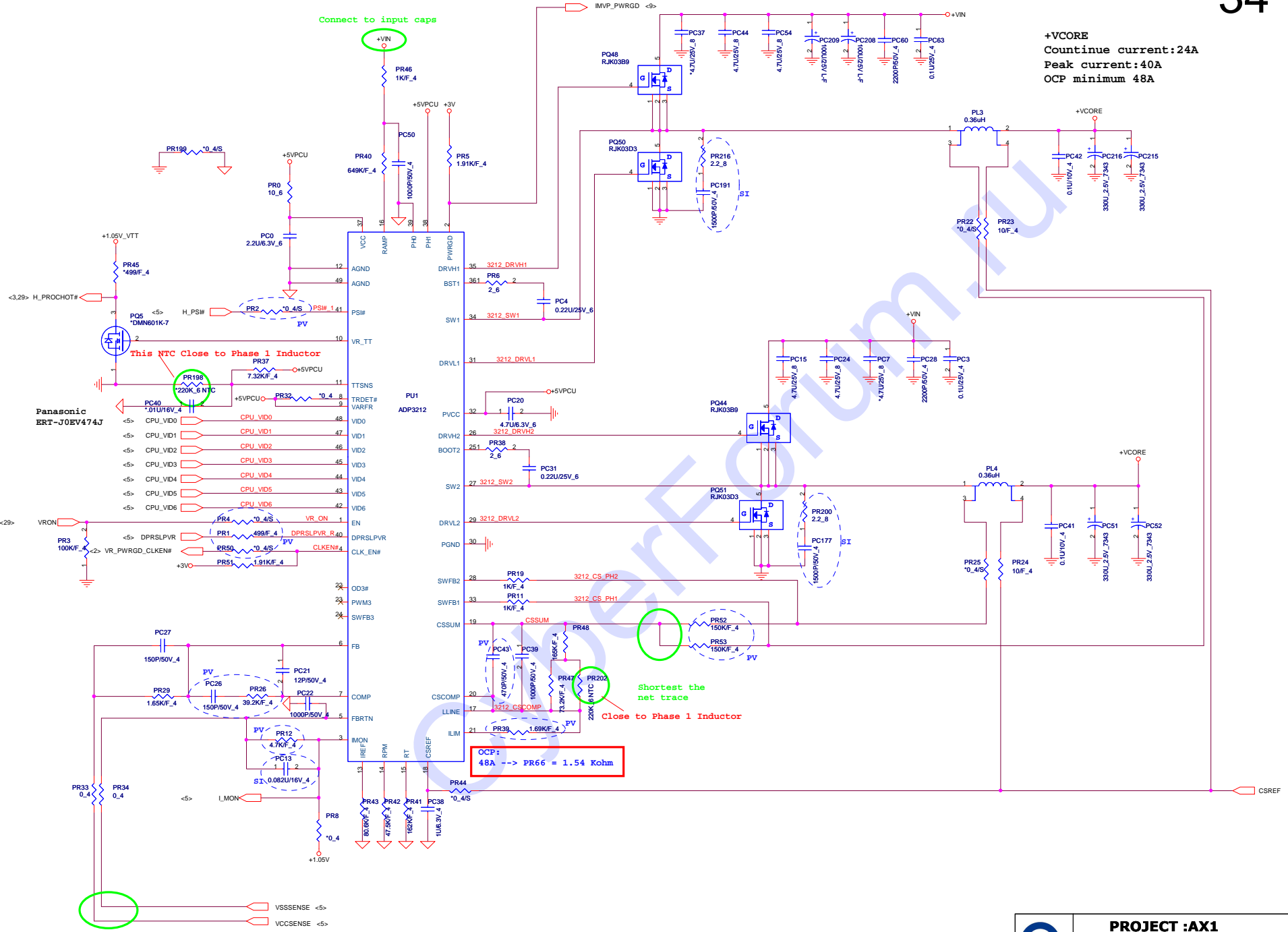

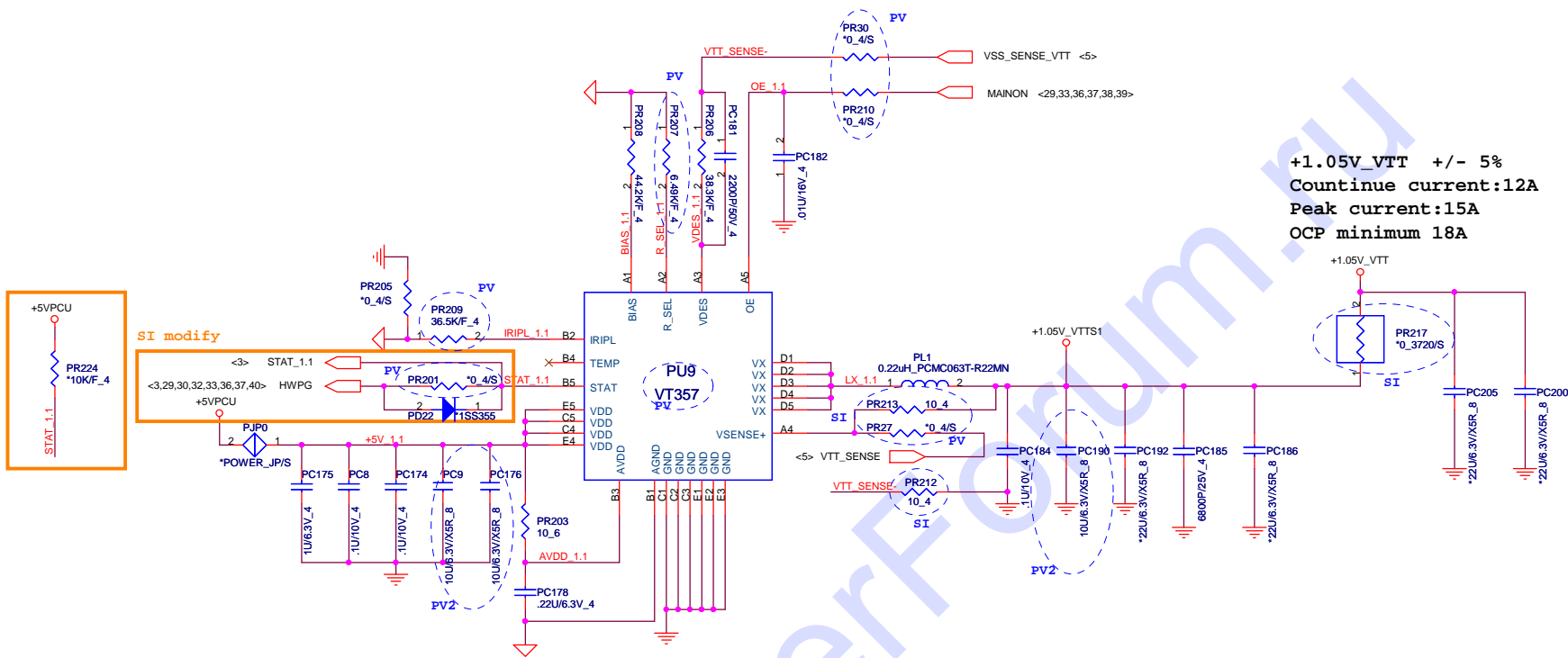

**+1.05V\_VTT +/- 5%**  
**Countinue current:12A**  
**Peak current:15A**  
**OCP minimum 18A**

CyberForum



**PROJECT :AX1**  
**Quanta Computer Inc.**

Size Custom	Document Number <b>+1.05V_VTT (VT358)</b>	Rev 1A
Date: Thursday, November 12, 2009 Sheet 35 of 40		

**+VGA\_CORE +/- 5%**  
**Countinue current:8A**  
**Peak current:10.5A**  
**OCP minimum 12A**

	PWRCNTL0	PWRCNTL1	V-CORE
L	0	0	0.9V
M	0	1	0.95V
H	1	0	1.05V
TBD	1	1	NA

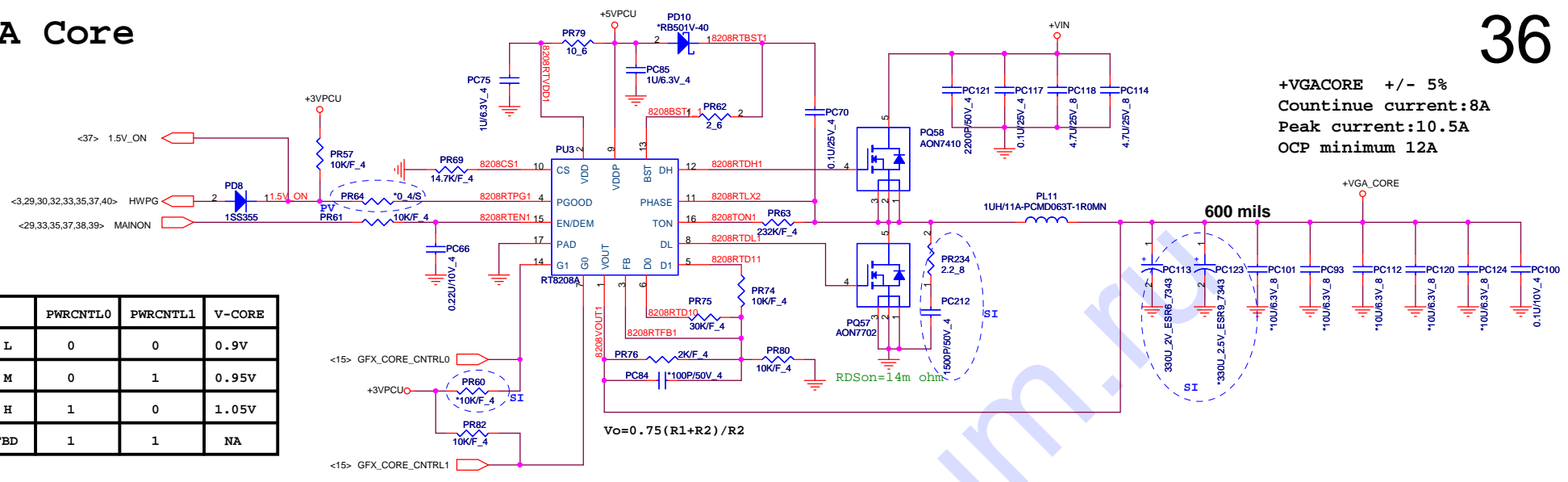

**+1.8V +/- 5%**  
**Countinue current:1.2A**  
**Peak current:3A**

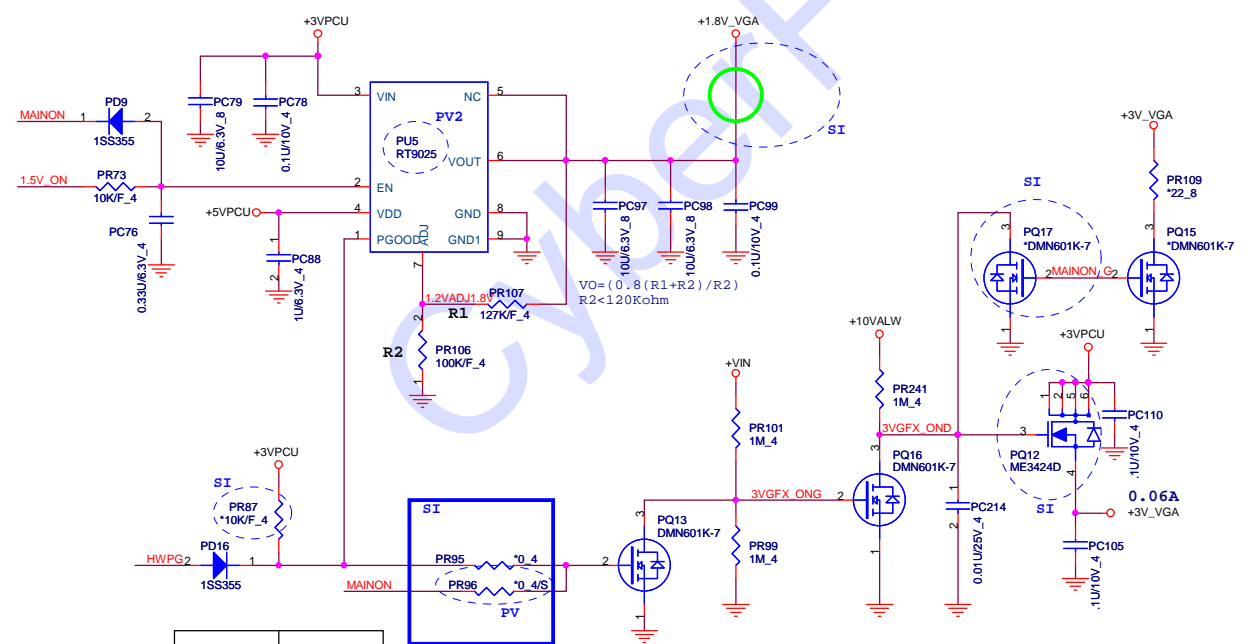

PR95	For M93
PR96	For PARK



**PROJECT :AX1**  
**Quanta Computer Inc.**

+1.5V +/- 5%  
 Countinue current:6A  
 Peak current:12A  
 OCP minimum 15A

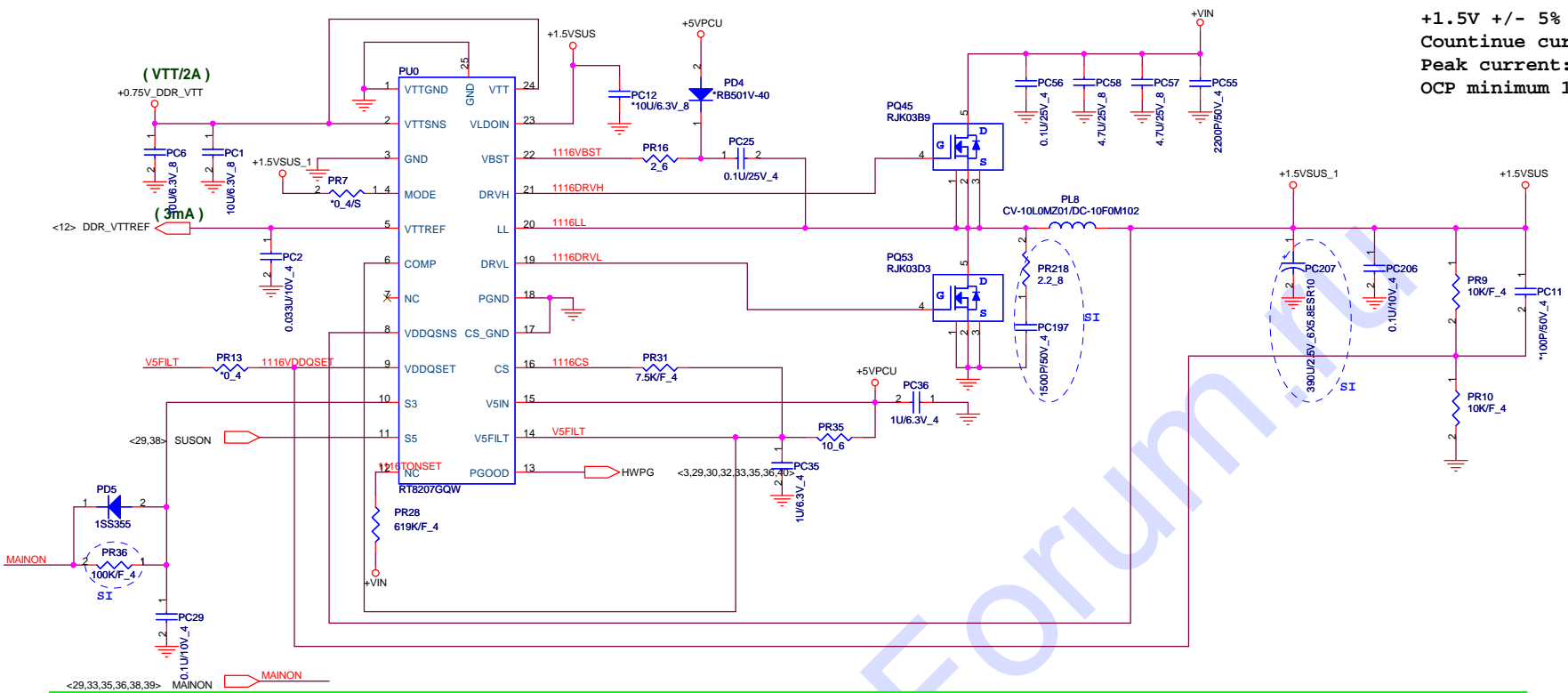

Discrete Only

+1.1V +/- 5%  
 Countinue current:2A  
 Peak current:3A

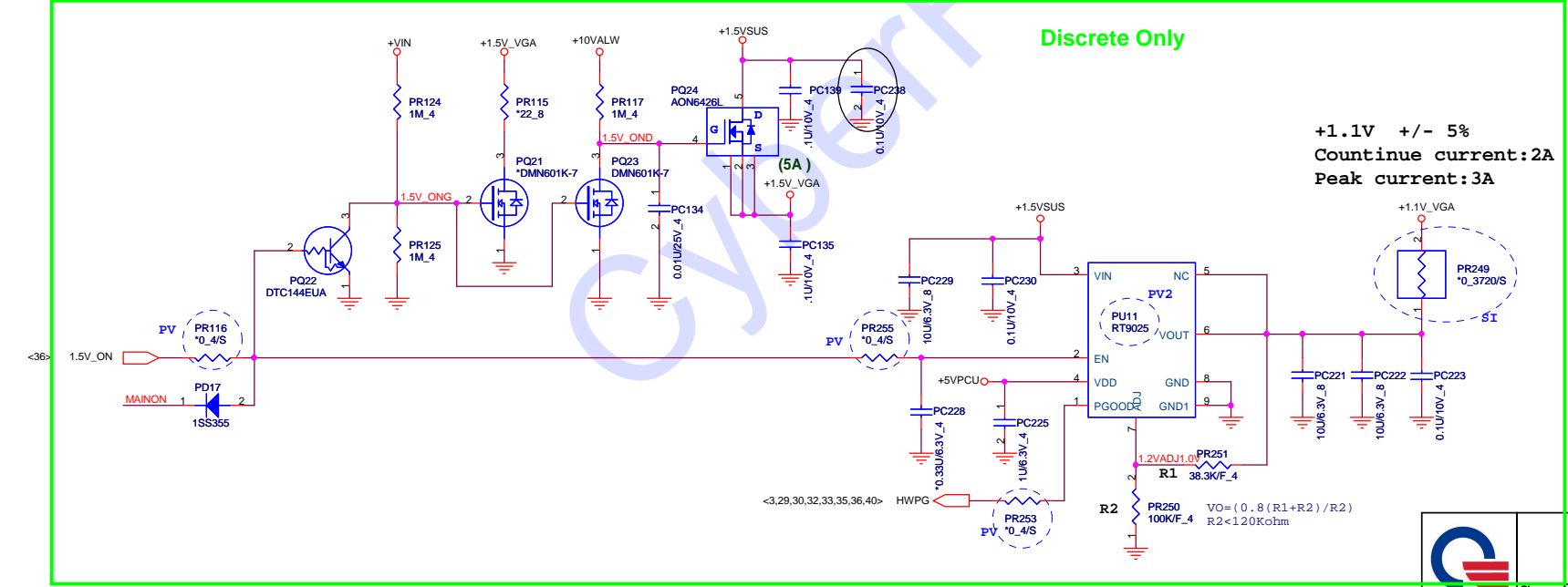

**PROJECT :AX1**  
**Quanta Computer Inc.**

Size Custom	Document Number <b>DDR3 (RT8207)</b>	Rev 1A
Date: Thursday, December 03, 2009   Sheet 37 of 40		

SI modify  
 MAIND <5>

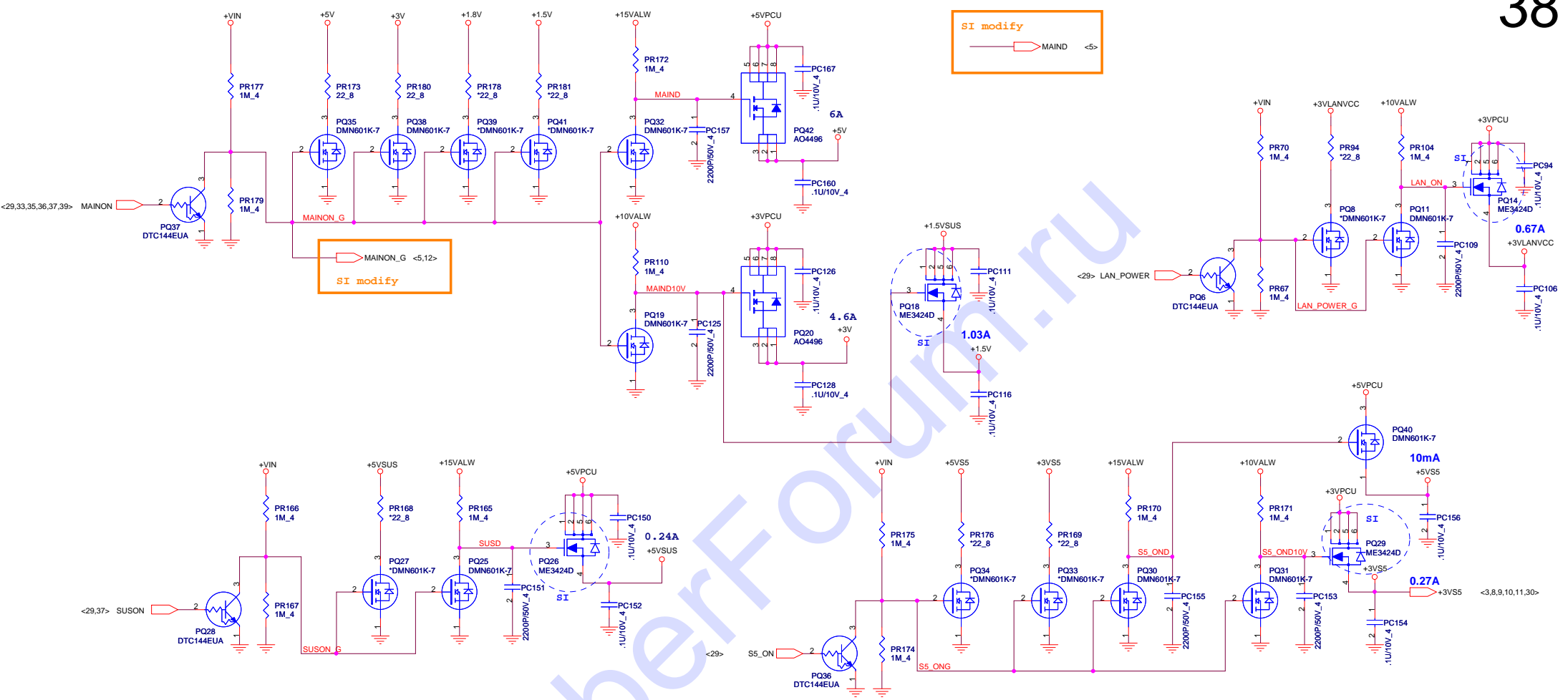



SI modify  
 MAINON\_G <5,12>

SI  
 0.24A

SI  
 1.03A

SI  
 0.27A

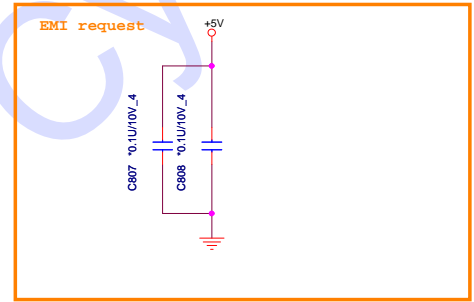
SI  
 0.67A

**PROJECT :AX1**  
 Quanta Computer Inc.

Size Custom	Document Number <b>DISCHARGE/3VS5/5VS5/LAN</b>	Rev 1A
Date: Thursday, November 12, 2009	Sheet 38 of 40	



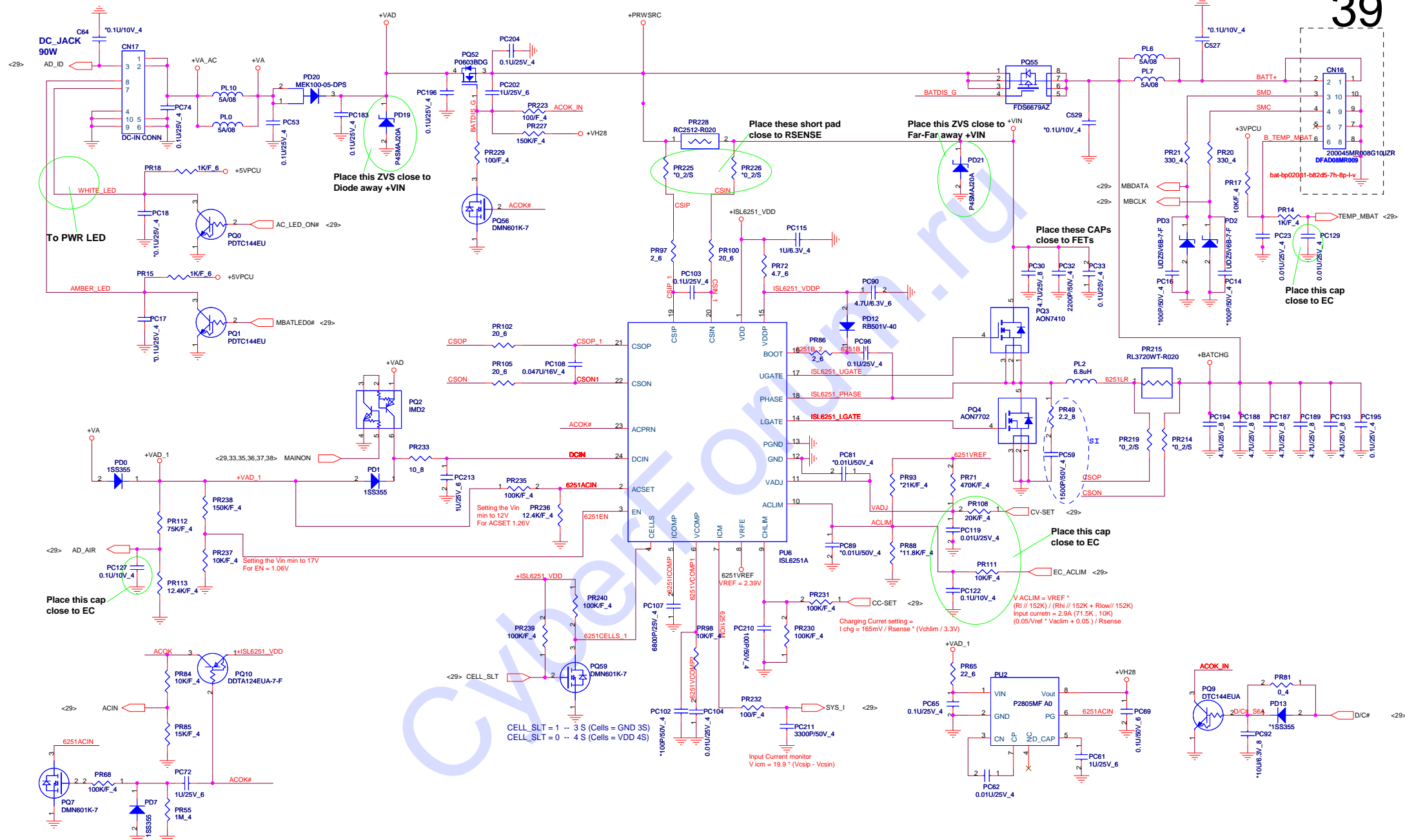

**PROJECT :AX1**  
**Quanta Computer Inc.**

Size Custom	Document Number	Rev 1A
	<b>CHARGER (ISL6251)</b>	
Date: Thursday, November 12, 2009		Sheet 39 of 40

