

# Bond, SP6 BLOCK DIAGRAM

## 12L HDI

TOP  
 GND1  
 IN1  
 GND2  
 IN2  
 GND3  
 VCC  
 IN3  
 GND4  
 IN4  
 GND3  
 BOT

**2'nd battery Docking**  
 PAGE 40

**SYSTEM CHARGER (ISL6251AHAZ-T)**  
 PAGE 37

**SYSTEM POWER ISL6237IRZ-T**  
 PAGE 38

**DDR II SMD DR\_VTERM 1.8V/1.8VSUS (TPS51116REGR)**  
 PAGE 42

**VCCP +1.5V AND GMCH 1.05V (RT8204)**  
 PAGE 39

**VGACORE (1.025V) Oz8119**  
 PAGE 41

**CPU CORE ISL6262A**  
 PAGE 40

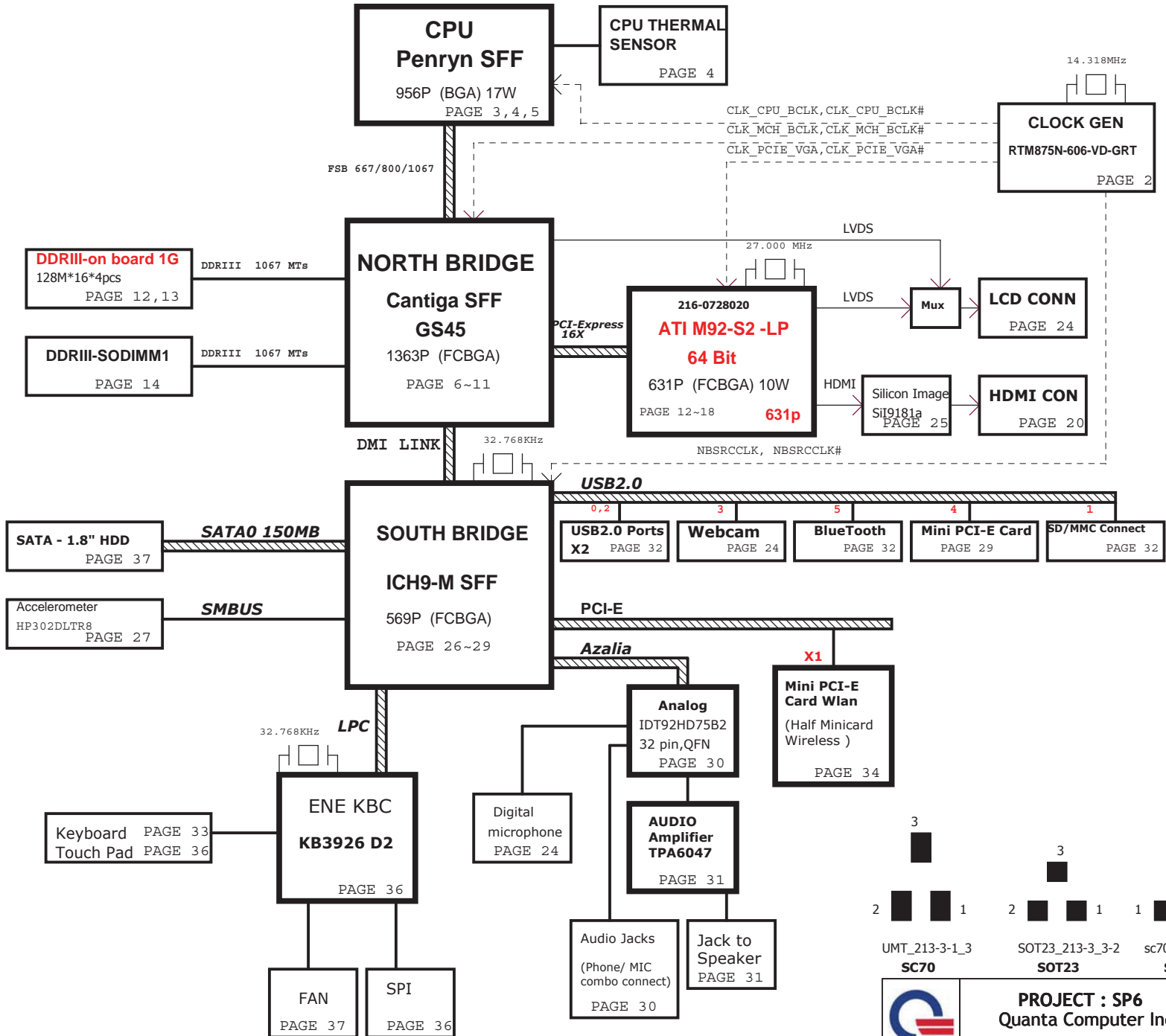

**PROJECT : SP6**  
**Quanta Computer Inc.**

NB5	Size Custom	Document Number	Rev 1A
	Block Diagram		
Date: Tuesday, April 07, 2009		Sheet 1	of 49

(4,7,10,12,14,24,25,26,27,28,29,30,31,32,33,34,35,36,45) +3V  
(3,4,5,6,7,9,10,26,29,42,44) +1.05V

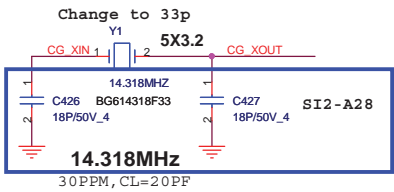
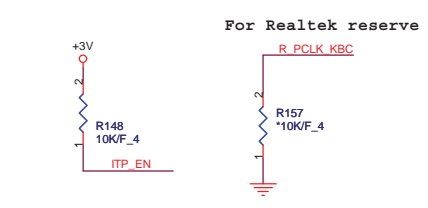
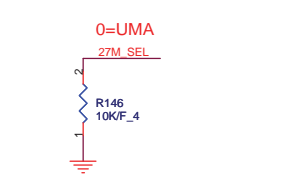
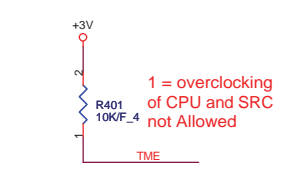
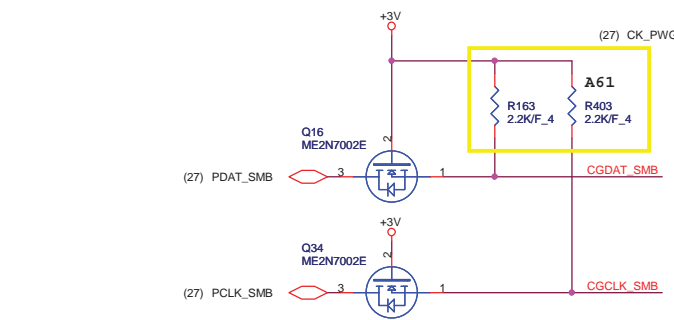
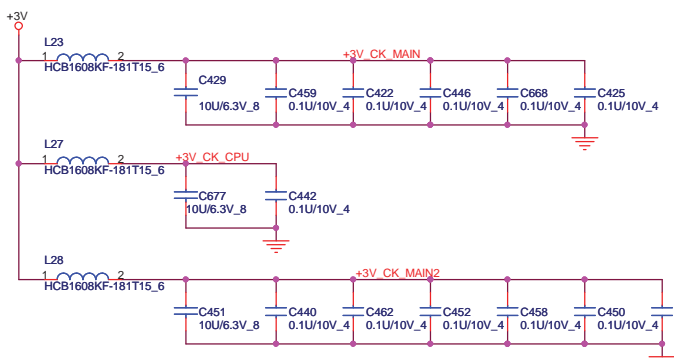

27M_SEL PIN13	PIN20	PIN21	PIN24	PIN25
0=UMA	DOT96T	DOT96C	SRCT1/LCDT_100	SRCT1/LCDT_100
1 = External VGA	SRCT0	SRCC0	27Mout-NSS	27Mout-SS

**CPU Clock select**

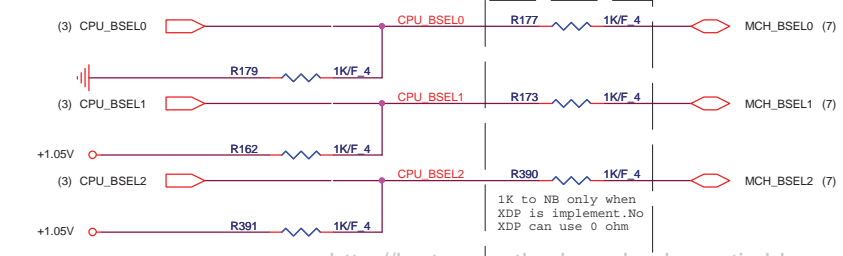

FSC	FSB	FSA	CPU	SRC	PCI
1	0	1	100	100	33
0	0	1	133	100	33
0	1	1	166	100	33
0	1	0	200	100	33
0	0	0	266	100	33
1	0	0	333	100	33
1	1	0	400	100	33
1	1	1	RSVD	100	33

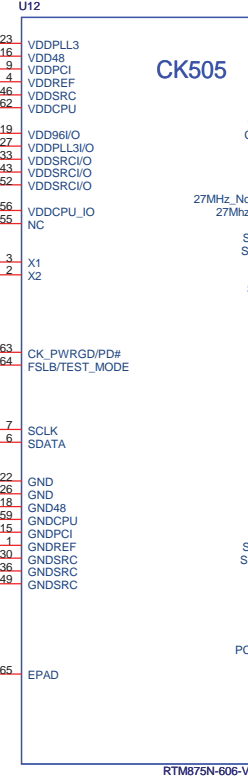

**CK505**  
Realtek  
Silego

**QFN64**  
RTM875N-606-VD-GR AL000875000  
SLG8SP513VTR AL8SP513000

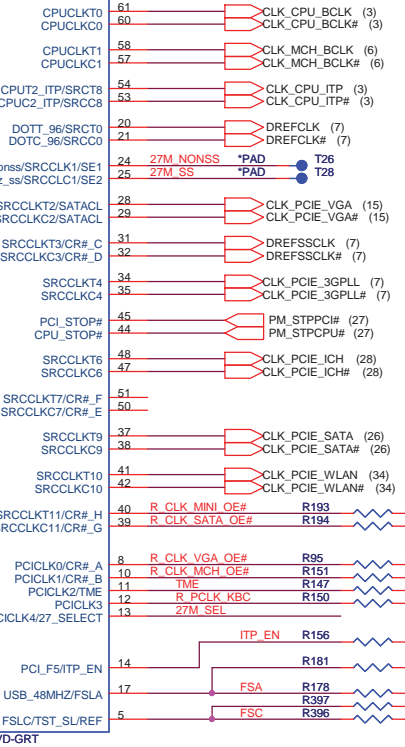

CR#	B	SRC	1,4	CLK_MCH_OE#	SRC4
CR#	A	SRC	0,2	CLK_VGA_OE#	SRC2
CR#	G	SRC	9	CLK_SATA_OE#	SRC9
CR#	H	SRC	10	CLK_MINI_OE#	SRC10

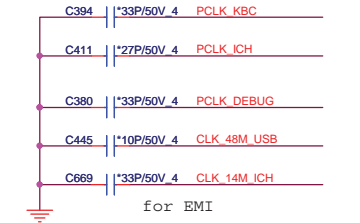
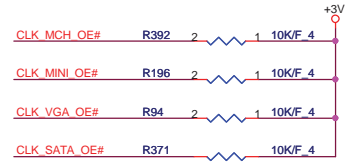

**PROJECT : SP6**  
Quanta Computer Inc.

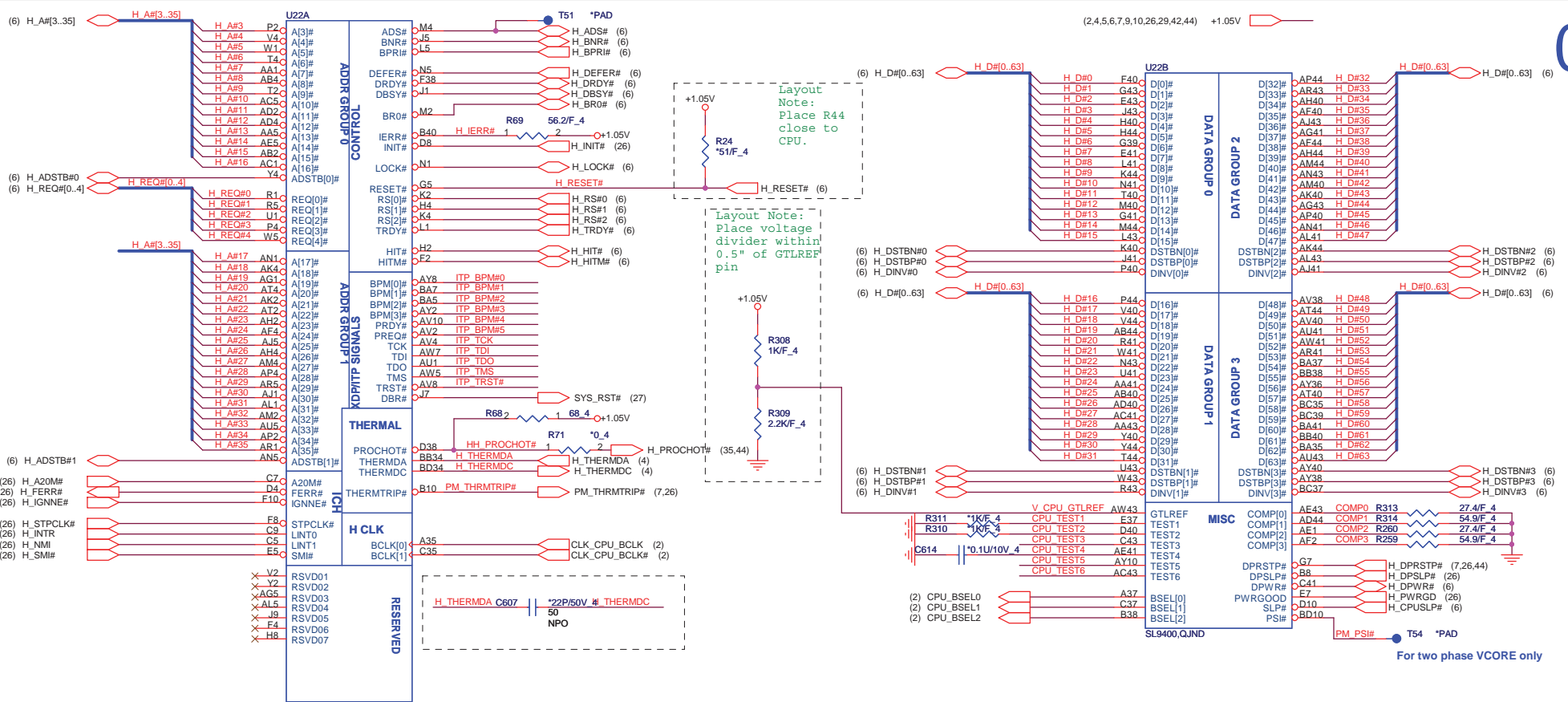

- SL9400: AJSLB66UT01 CPU(956P)PENRYN 1.86G SLB66(FCBGA)TOPB/S
- SL9400: AJSLB66UT02 CPU(956P)PENRYN 1.86G SLB66(FCBGA)
- SL9600: AJSLGEQT01 CPU(956P)PENRYN 2.13G SLGEQ(BGA)TOPB/S
- SL9600: AJSLGEQT00 CPU(956P)PENRYN 2.13G SLGEQ(BGA)

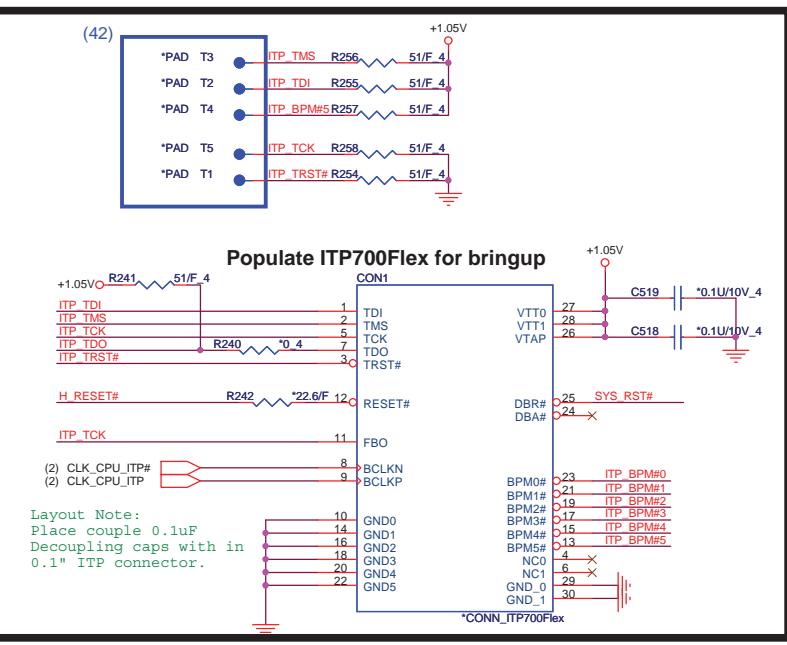

\*PAD T78 CPU TEST3  
 \*PAD T53 CPU TEST5  
 \*PAD T77 CPU TEST6

For the purpose of testability, route these signals through a ground referenced Z0 - 55ohm trace that ends in a via that is near a GND via and is accessible through an oscilloscope connection.

Signal | ITP disable guidelines

Signal	Resistor Value	Connect To	Resistor Placement
TDI			
TMS	150 ohm +/- 5%	VTT	Within 2.0" of the ITP
TRST#	39 ohm +/- 5%	VTT	Within 2.0" of the ITP
TCK	680 ohm +/- 5%	VTT	Within 2.0" of the ITP
TDO	27 ohm +/- 5%	OpenGND	Within 2.0" of the ITP
ITP_EN		GND	Within 2.0" of the ITP
	R268 Depop	VTT	Within 2.0" of the ITP
		+3VRUN	Close to CK410M Pin8

**PROJECT : SP6**  
**Quanta Computer Inc.**

NBS

Size Custom | Document Number Penryn (HOST BUS) 1/3 | Rev 1A

Date: Tuesday, April 07, 2009 | Sheet 3 of 49

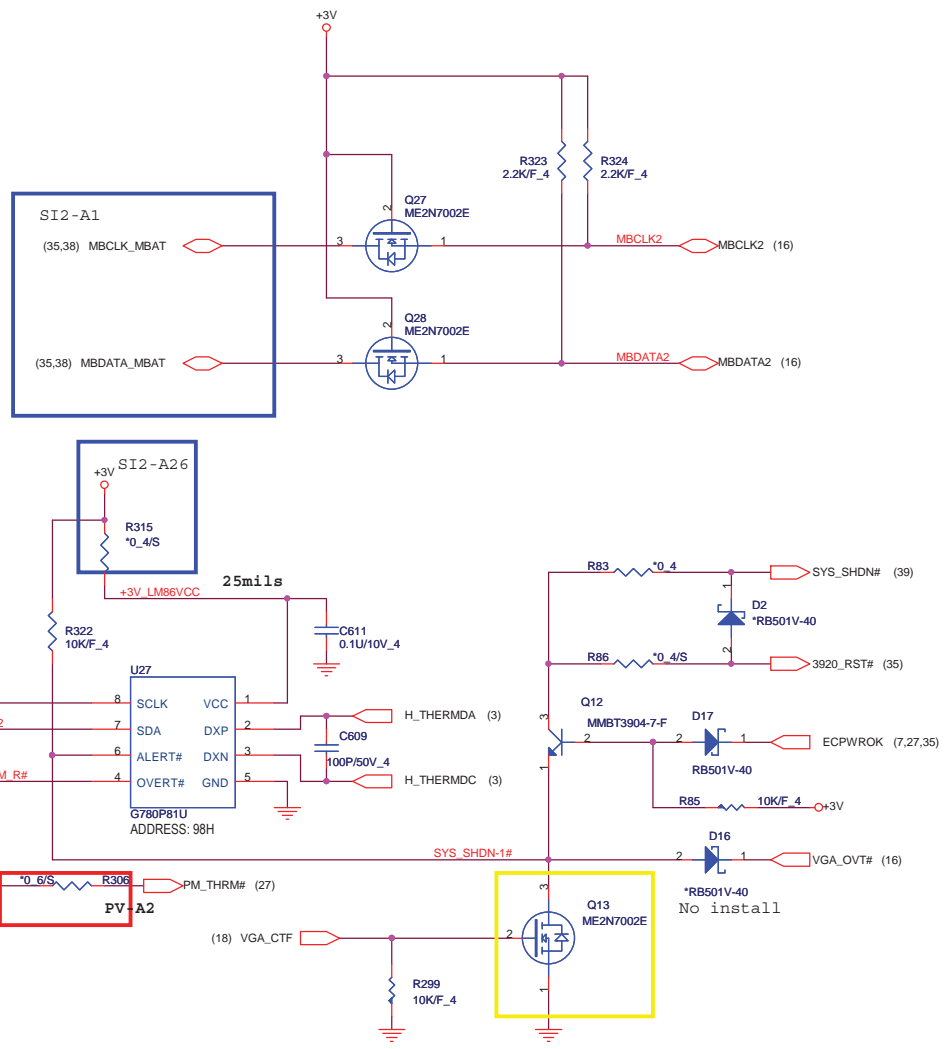
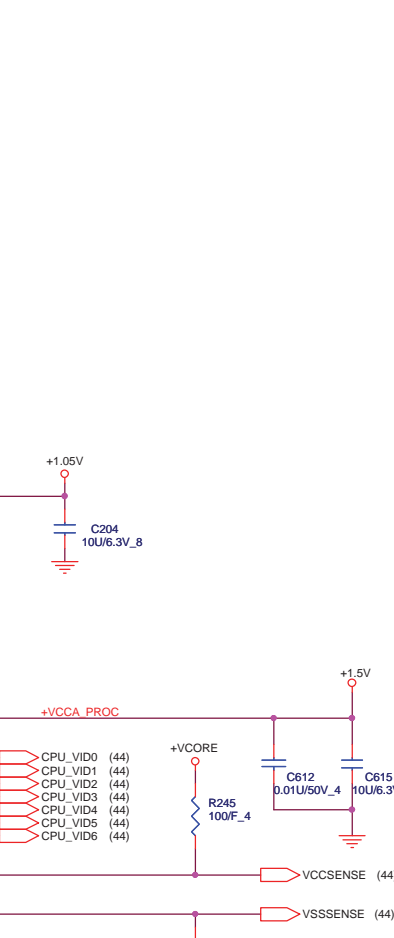
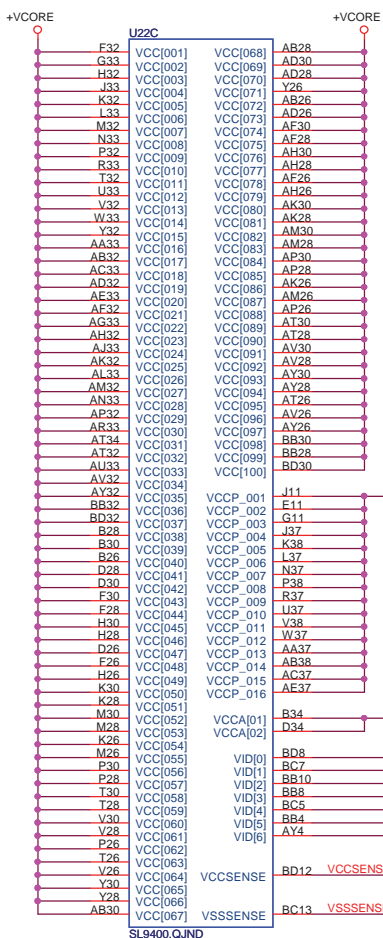
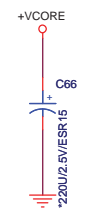
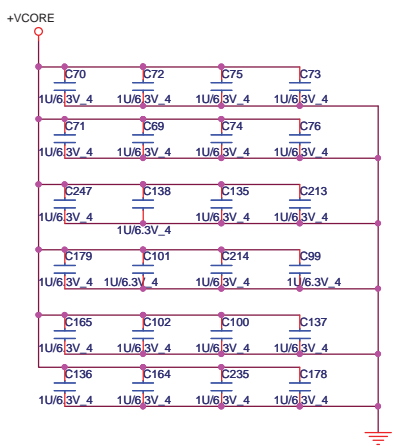
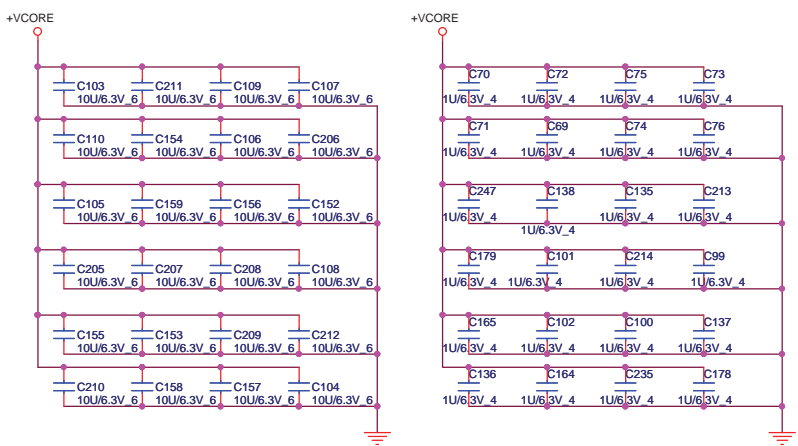

**PROJECT : SP6**  
**Quanta Computer Inc.**

NB5	Size Custom	Document Number	Rev 2B
	Penryn & TH Monitor 2/3		
Date: Tuesday, April 07, 2009		Sheet 4	of 49



U22F  
SL9400,QJND



U22E  
SL9400,QJND

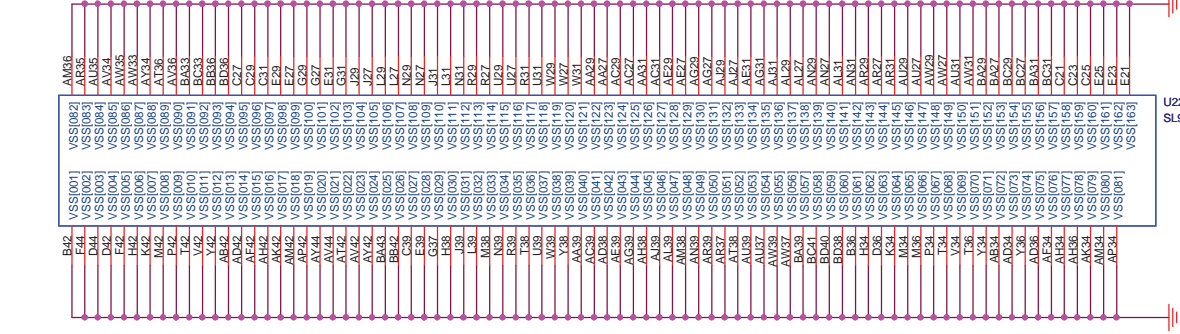

U22D  
SL9400,QJND

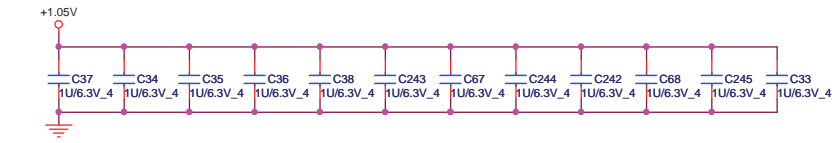

PROJECT : SP6  
Quanta Computer Inc.

Size Custom	Document Number Penryn 3/3	Rev 1A
Date: Tuesday, April 07, 2009	Sheet 5 of 49	

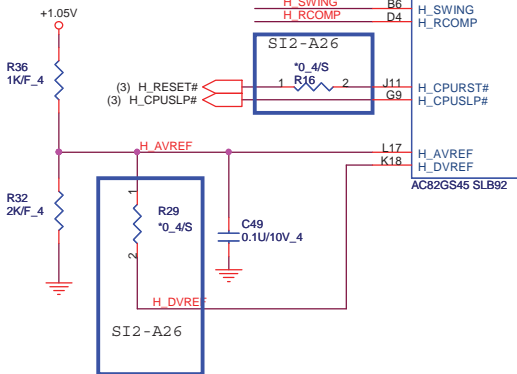
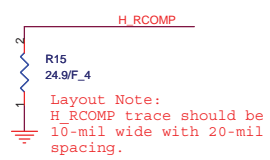
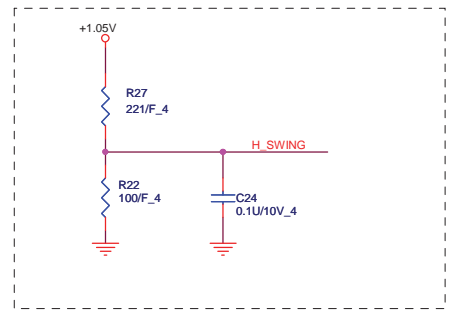
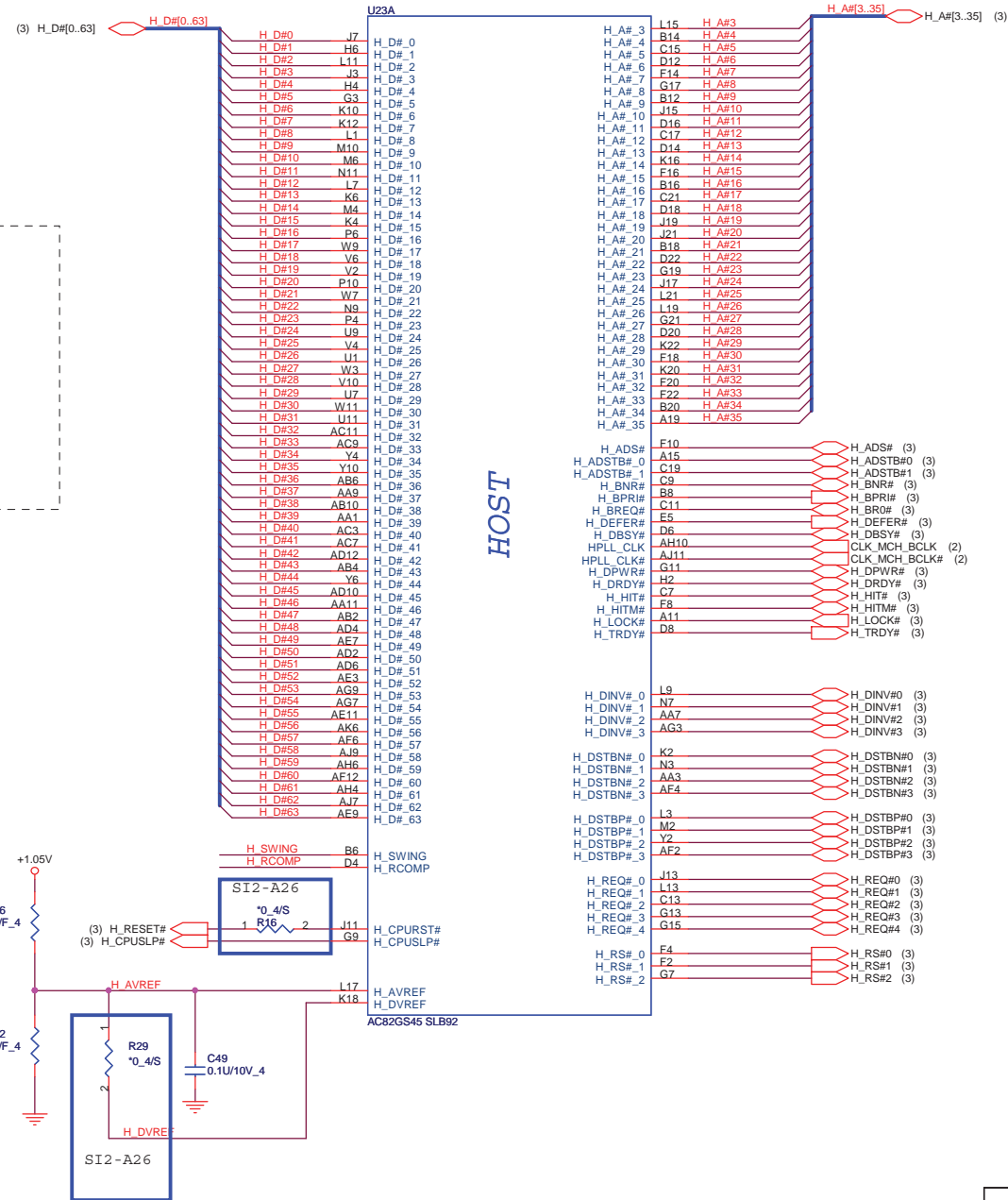

	<b>PROJECT : SP6</b> <b>Quanta Computer Inc.</b>	
	Size Custom Document Number <b>Cantiga hot</b>	Date: Tuesday, April 07, 2009 Sheet 6 of 49

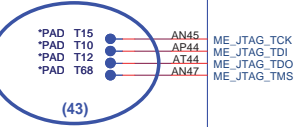
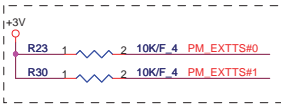
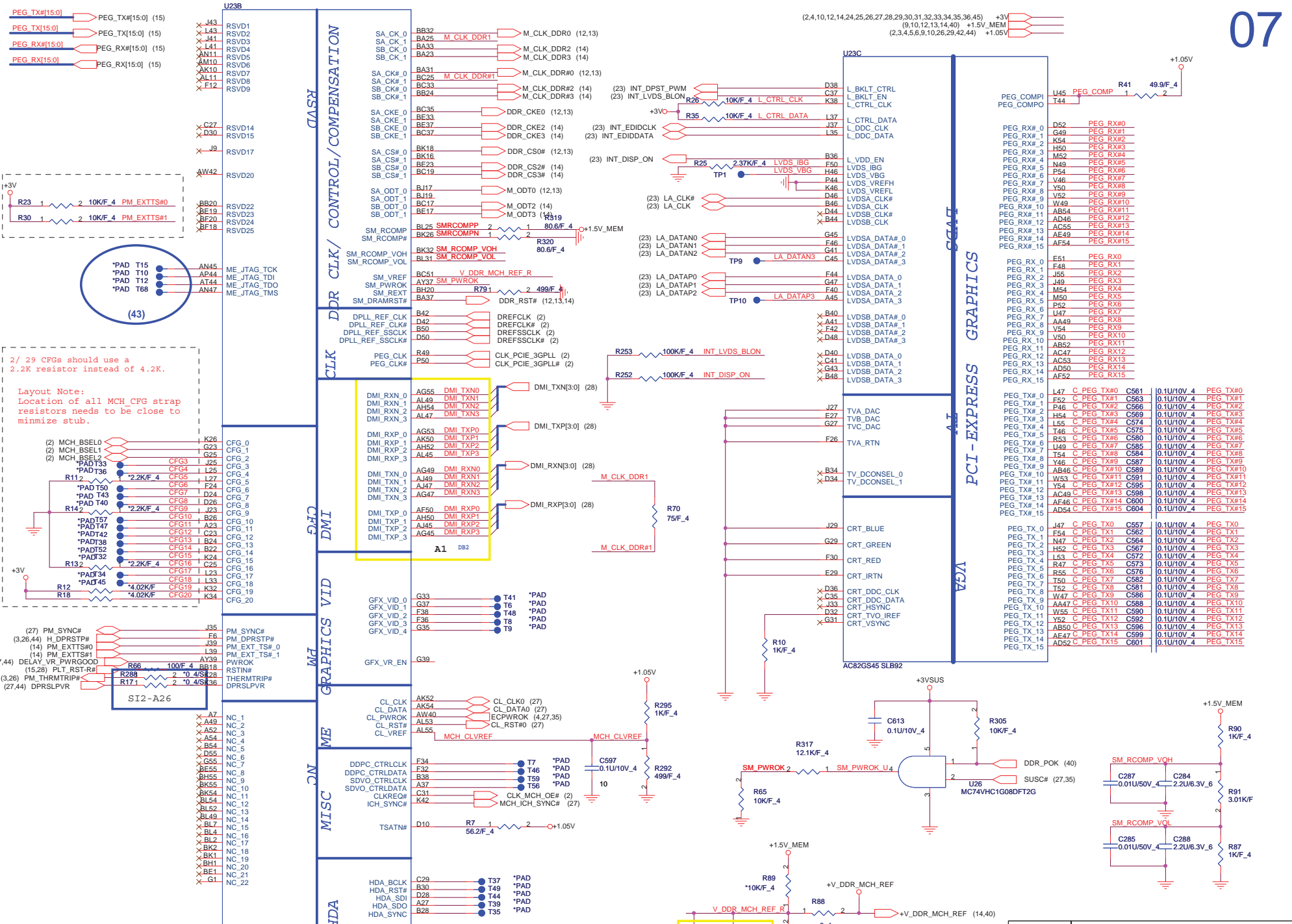

2/ 29 CFGs should use a 2.2K resistor instead of a 4.2K.

Layout Note: Location of all MCH\_CFG strap resistors needs to be close to minimize stub.

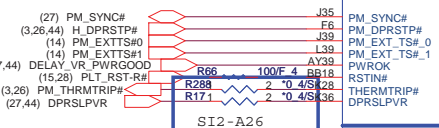
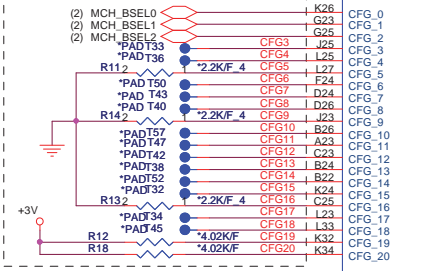

**PROJECT : SP6**  
**Quanta Computer Inc.**

Size Custom	Document Number Cantiga (VGA/DMI)	Rev 1A
Date: Tuesday, April 07, 2009	Sheet 7 of 49	

(12,13) DDR\_A\_D[0..63]

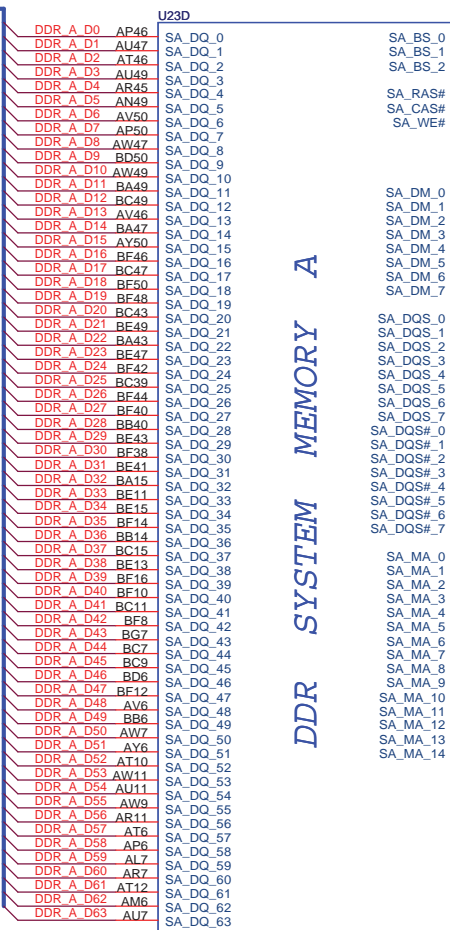

AC82GS45 SLB92

(14) DDR\_B\_D[0..63]

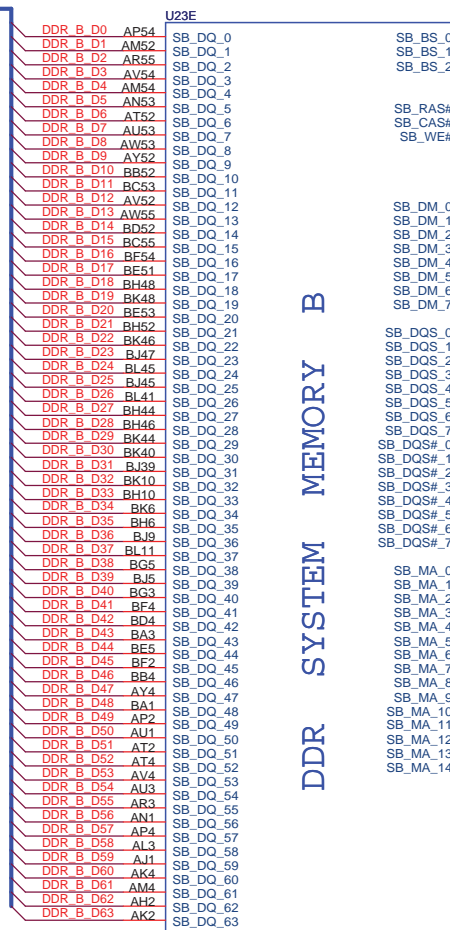

AC82GS45 SLB92

DDR SYSTEM MEMORY A

DDR SYSTEM MEMORY B

	<b>PROJECT : SP6</b>		Rev 1A
	Quanta Computer Inc.		
	Size Custom	Document Number <b>Cantiga (DDR interface)</b>	
Date: Tuesday, April 07, 2009		Sheet 8 of 49	



Ivcc\_gm (DDR3, 1.5V, 1066MTs) -->4140mA

220U\_7343 USE HEIGHT = 1.8mm

IVCC\_AXG-->7700mA (GS45)

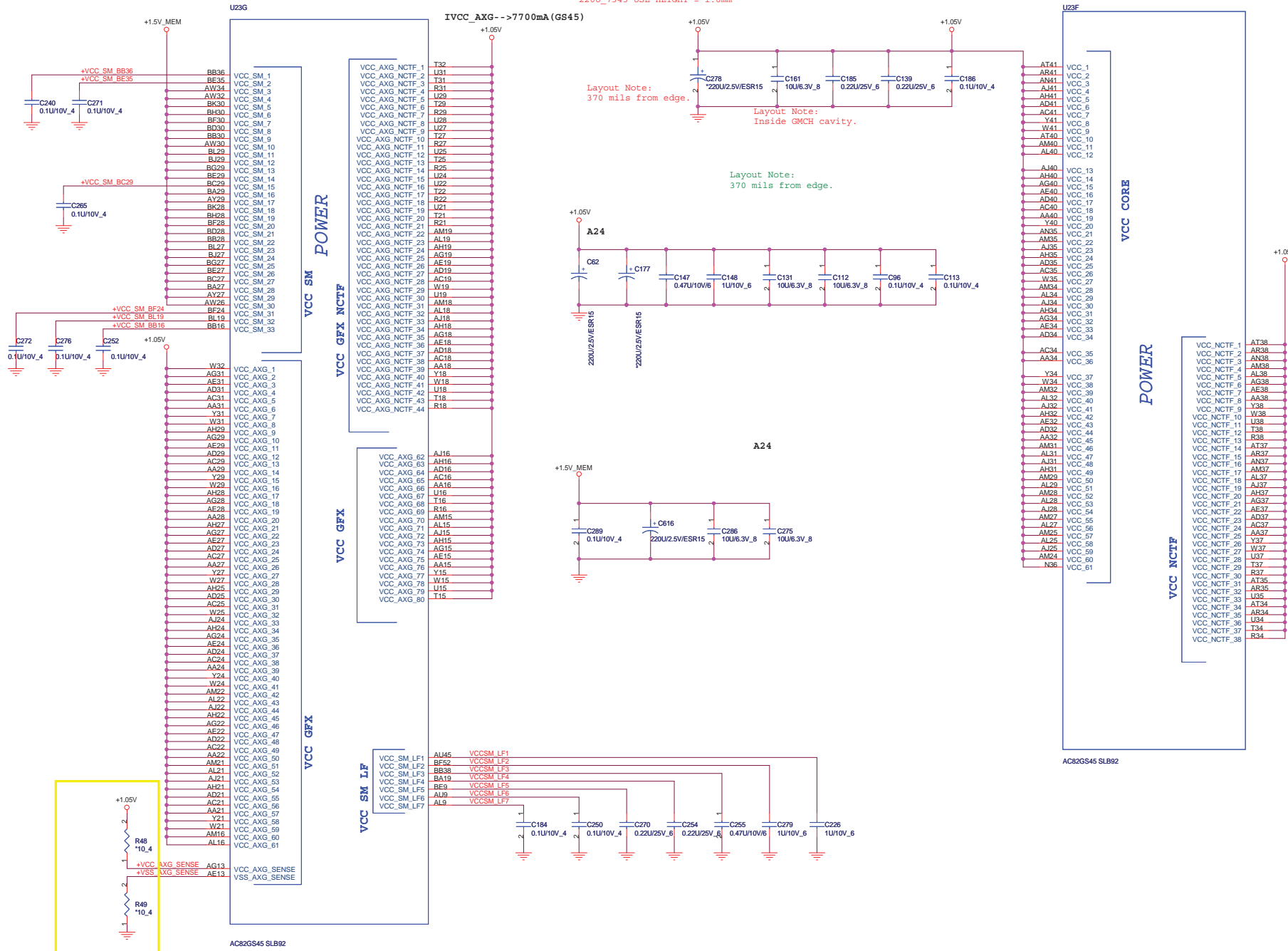

render standby feature is not implemented can be left

	<b>PROJECT : SP6</b>		Rev 1A
	Quanta Computer Inc.		
	Size Custom	Document Number <b>Cantiga (Vcc)</b>	
Date: Tuesday, April 07, 2009		Sheet 9 of 49	

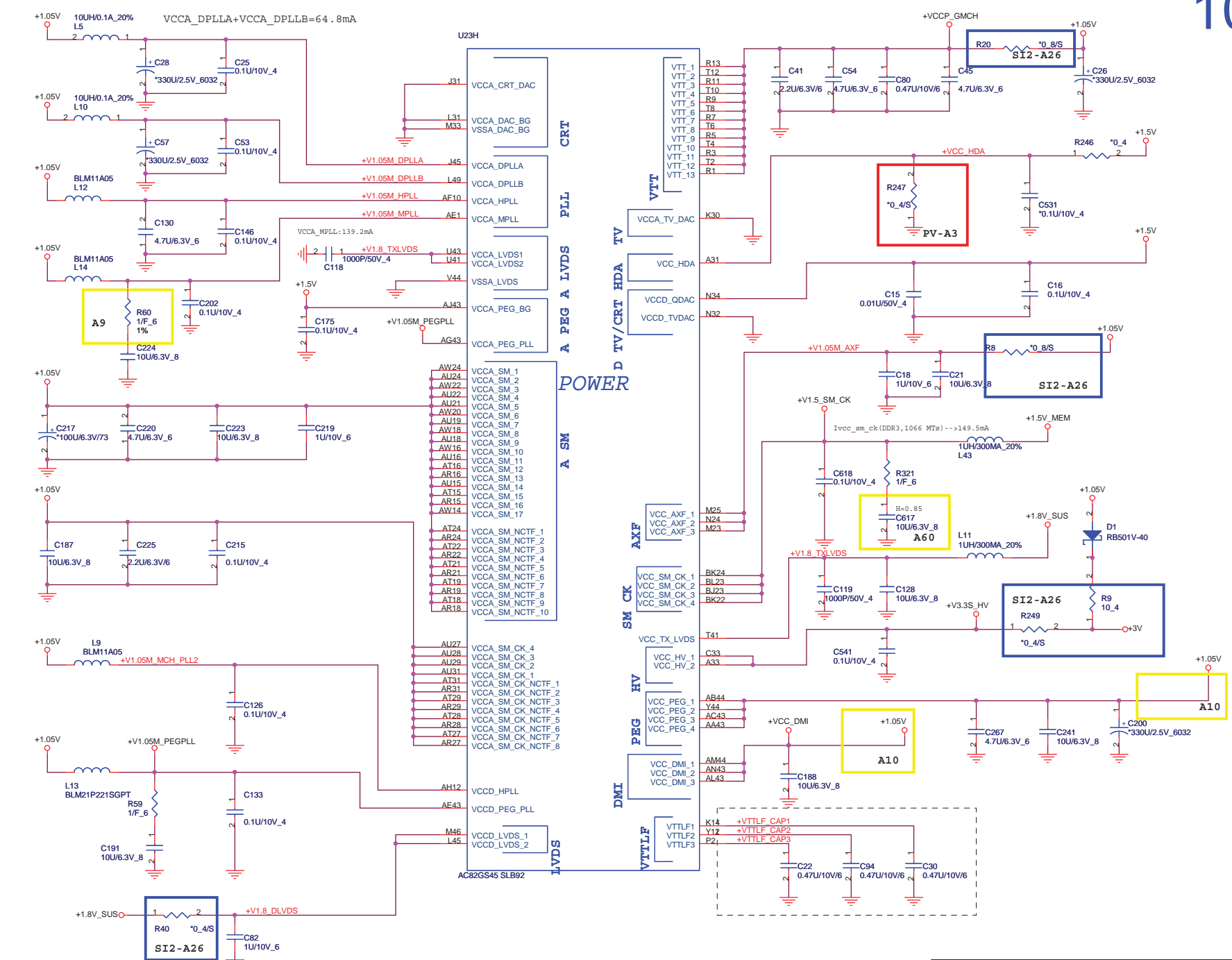

		<b>PROJECT : SP6</b>	
		<b>Quanta Computer Inc.</b>	
Size Custom	Document Number <b>Caniga (Power)</b>	Rev 1A	
Date: Tuesday, April 07, 2009		Sheet	10 of 49

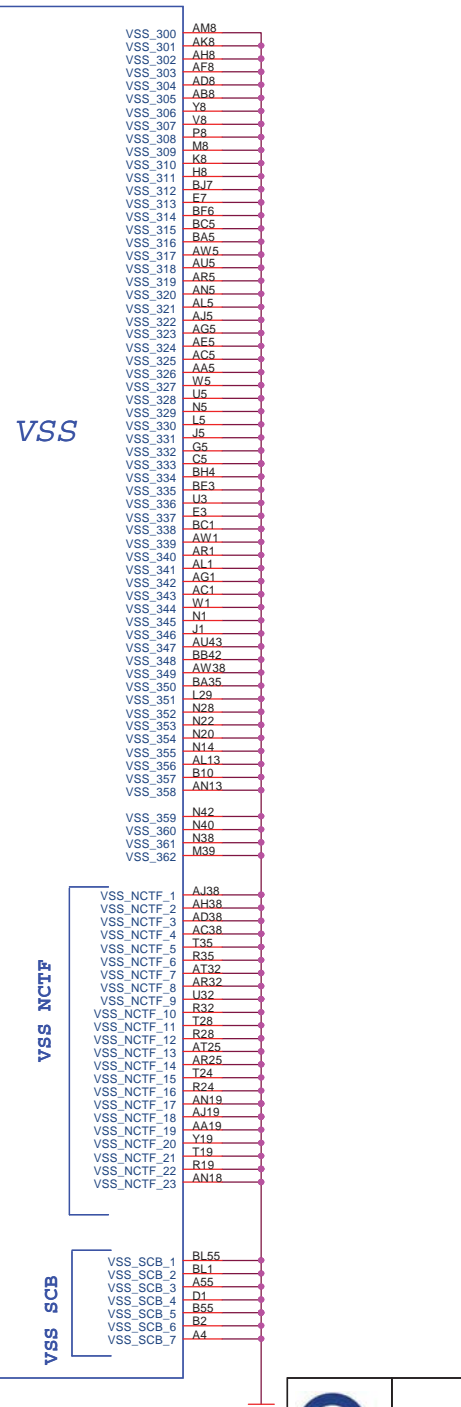
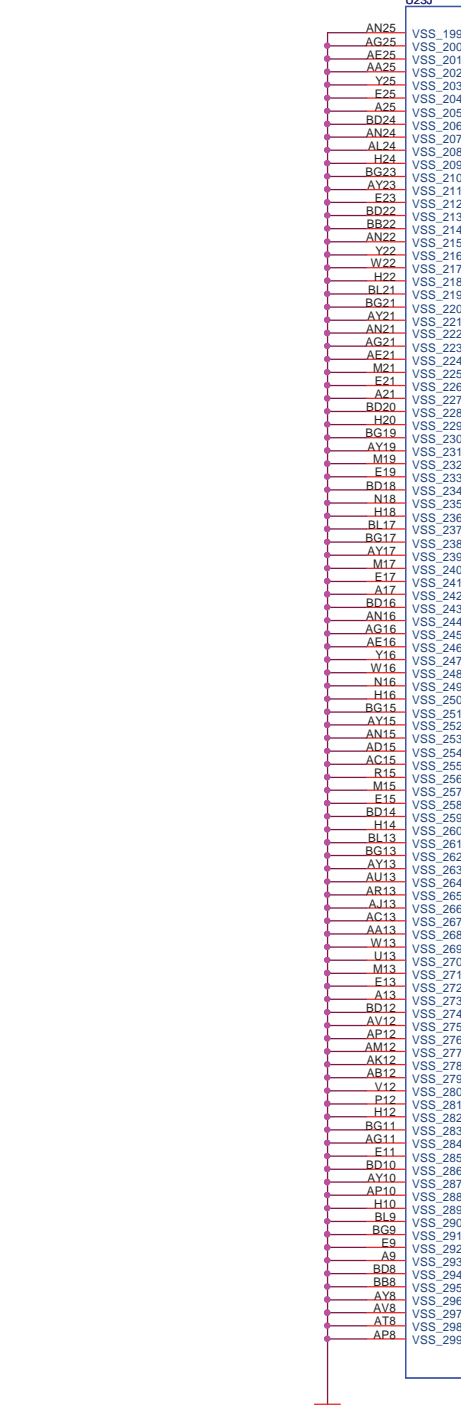
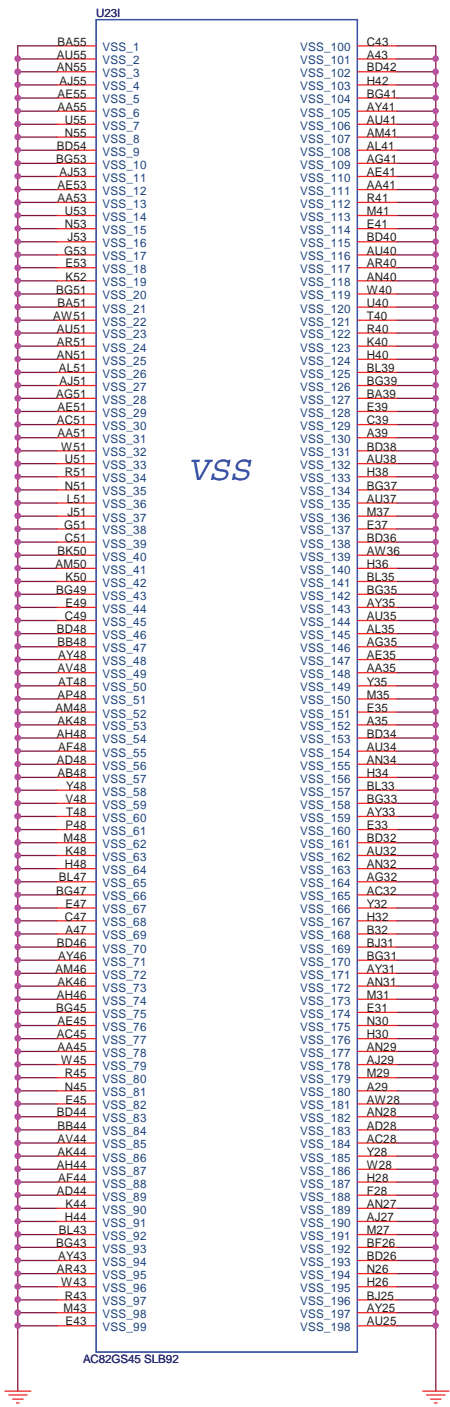

AC82GS45 SLB92

AC82GS45 SLB92

VSS NCTF  
VSS SCB



(7,9,10,13,14,40) +1.5V\_MEM  
(2,4,7,10,14,24,25,26,27,28,29,30,31,32,33,34,35,36,45) +3V  
(7,14,40) +V\_DDR\_MCH\_REF

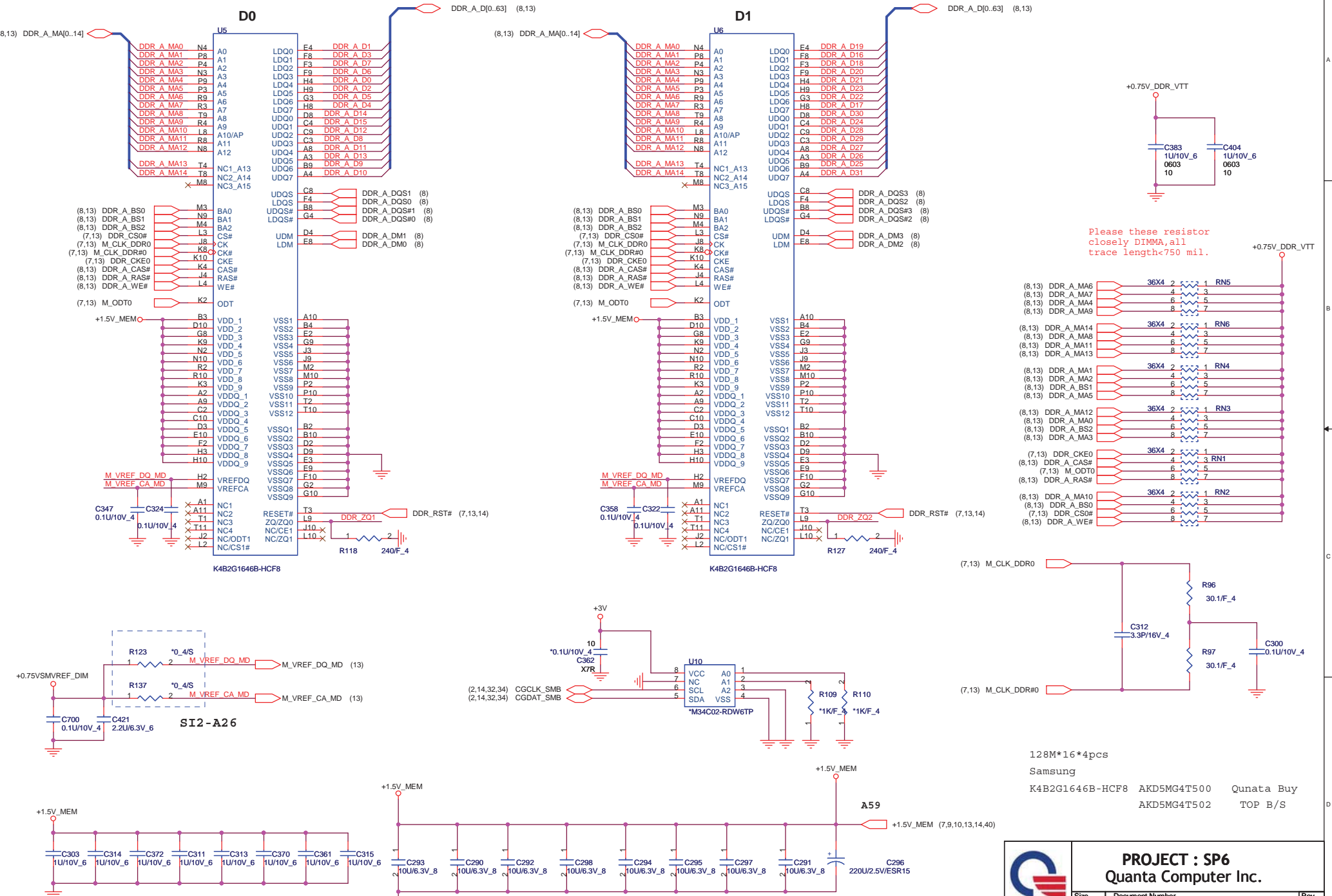

Please these resistor closely DIMMA, all trace length >= 750 mil.

128M\*16\*4pcs  
Samsung  
K4B2G1646B-HCF8 AKD5MG4T500 Qunata Buy  
AKD5MG4T502 TOP B/S

**PROJECT : SP6**  
**Quanta Computer Inc.**

NB5	Size Custom	Document Number	Rev 1A
		<b>DDR3 (A) On Board_A,1Rank</b>	
Date: Tuesday, April 07, 2009		Sheet 12	of 49

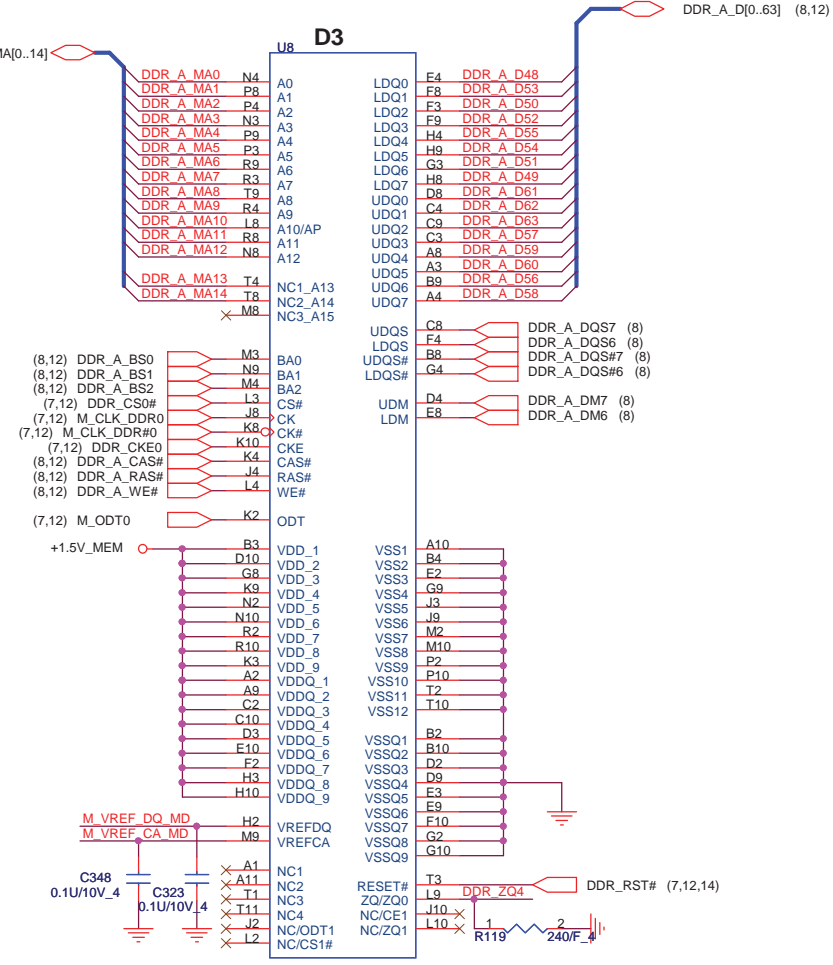
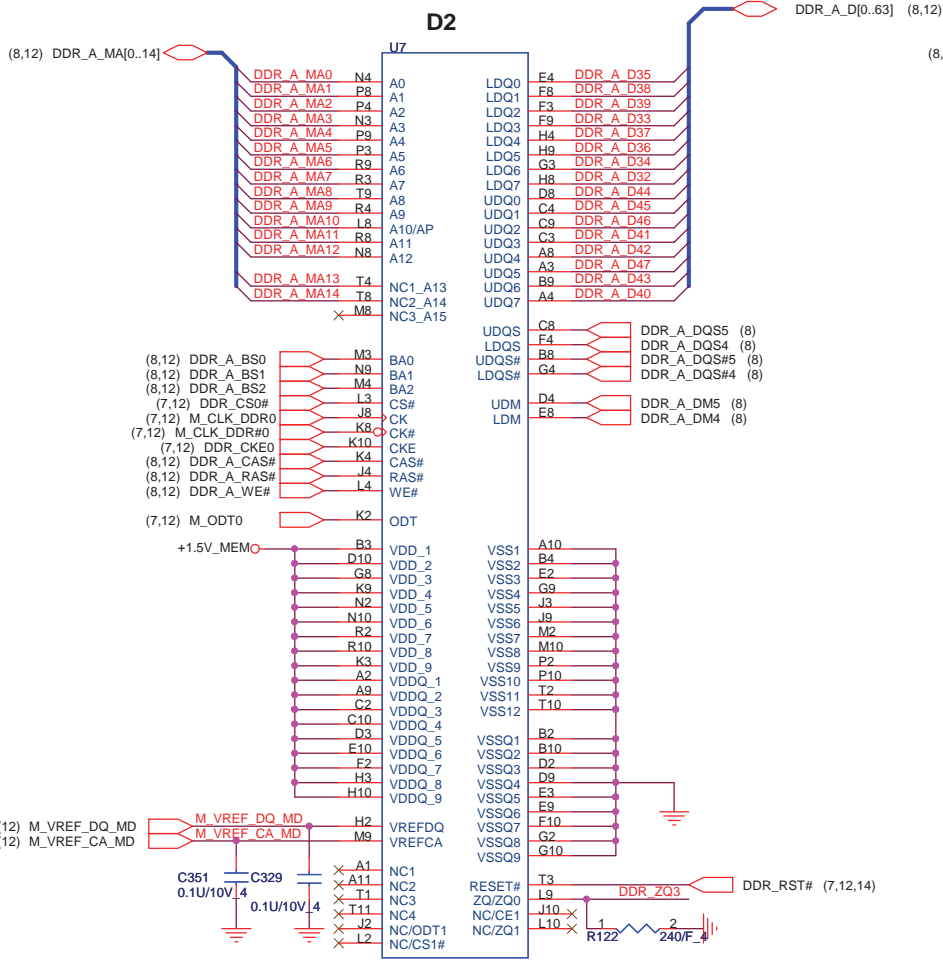

	<b>PROJECT : SP6</b>		Rev 1A
	<b>Quanta Computer Inc.</b>		
Size B	Document Number <b>DDR3 (A) On Board_B,1Rank</b>		
Date: Tuesday, April 07, 2009		Sheet 13 of 49	

0922-->CN23 update library to DDR-AS0A62X-U4RN-7F-204P type

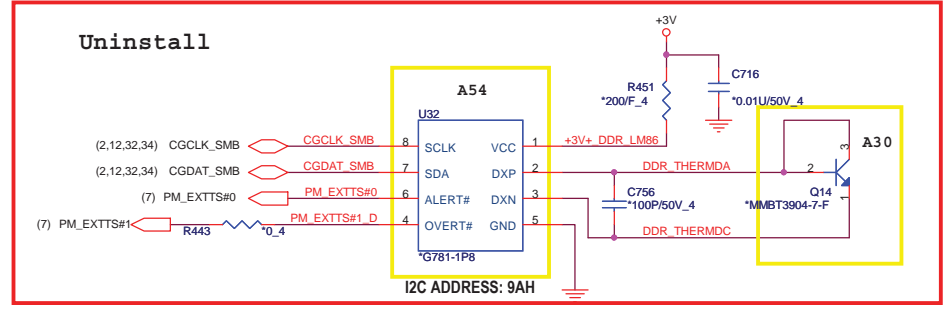
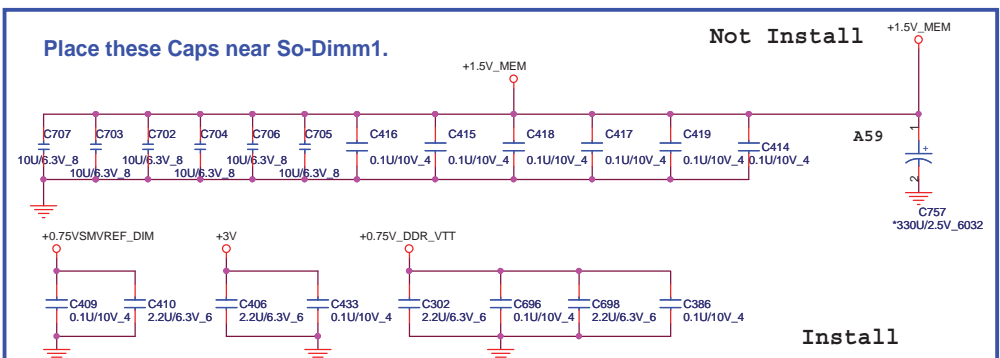
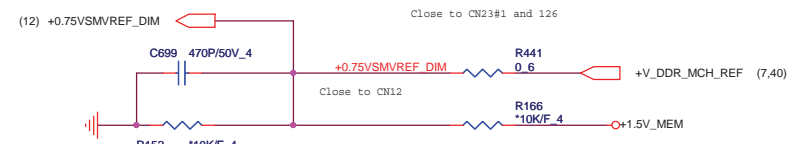
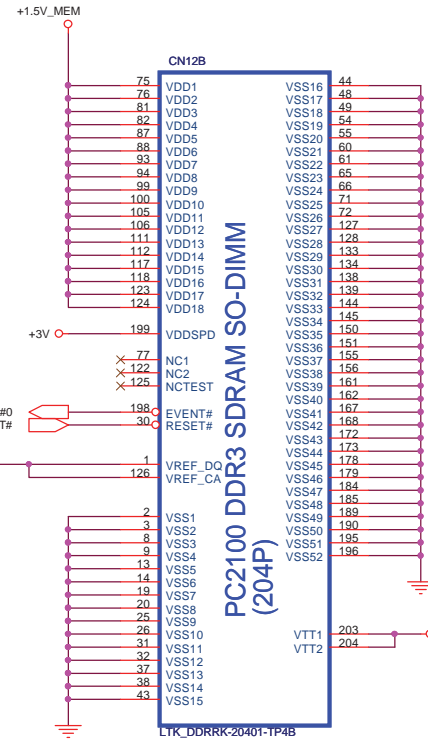
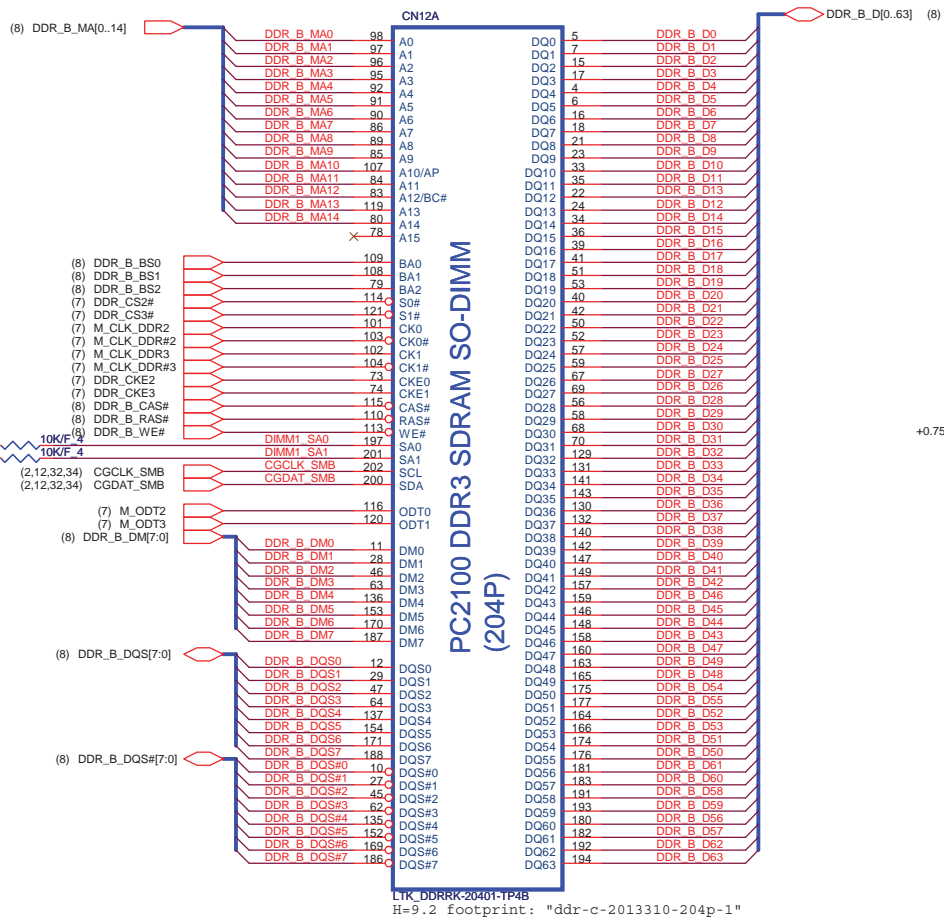
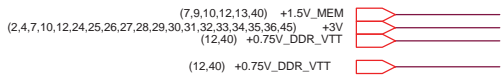

PROJECT : SP6  
Quanta Computer Inc.  
NB5  
Date: Tuesday, April 07, 2009  
Sheet 14 of 49  
Rev 1A

(17,18,19,20,40) +1.1V

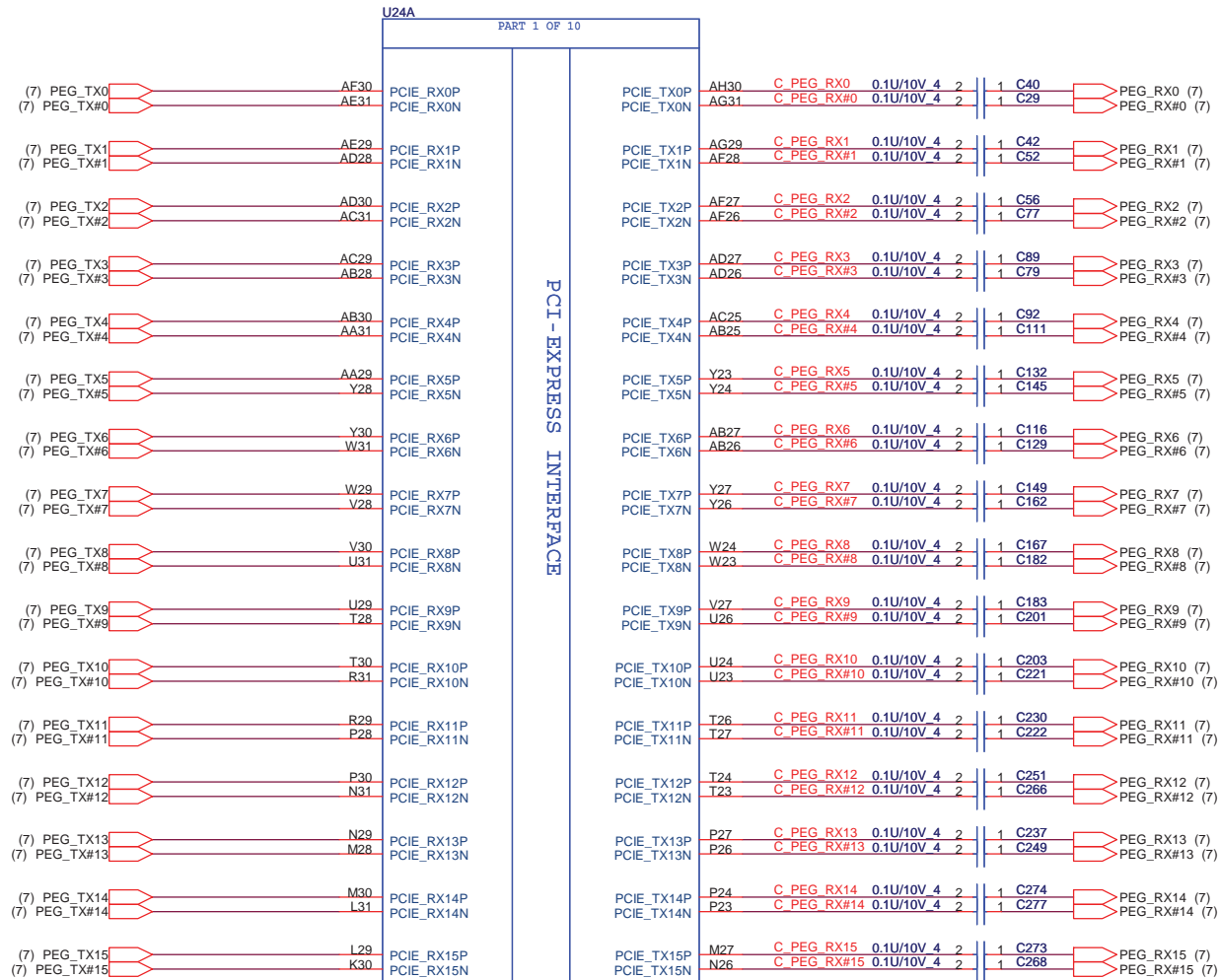

100 MHz (+/-300 ppm)  
input frequency, 0-0.7 V  
single-ended swing.  
clock must be provided  
less than 400ns  
after CLKREQ# is asserted

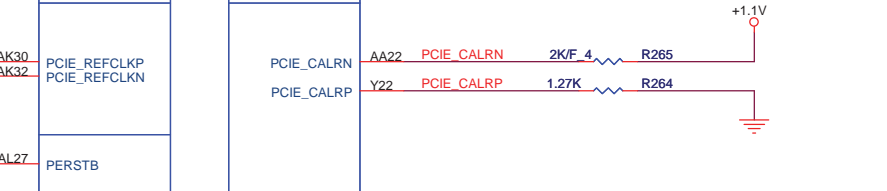
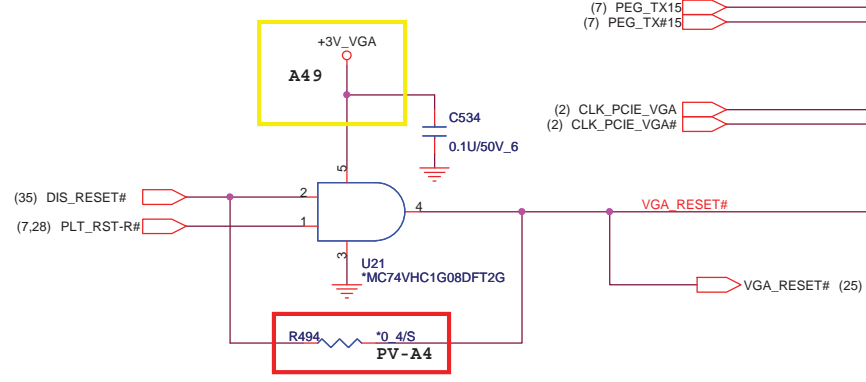

M92-S2-LP	AJ072800T18	100-CG1798 (216-0728020)
M92-S2-LP	AJ072800T21	100-CG1798 (216-0728020)

**PROJECT : SP6**  
**Quanta Computer Inc.**

Size B	Document Number <b>M92 PCIe interface</b>	Rev 1A
Date: Tuesday, April 07, 2009 Sheet 15 of 49		

# MEMORY INTERFACE



DIVIDER RESISTORS	DDR3
MVREF TO 1.5V	100R
MVREF TO GND	100R

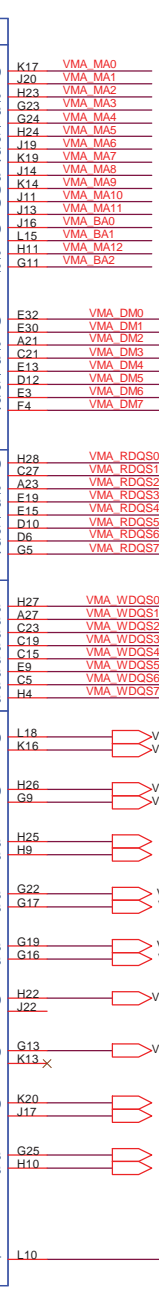
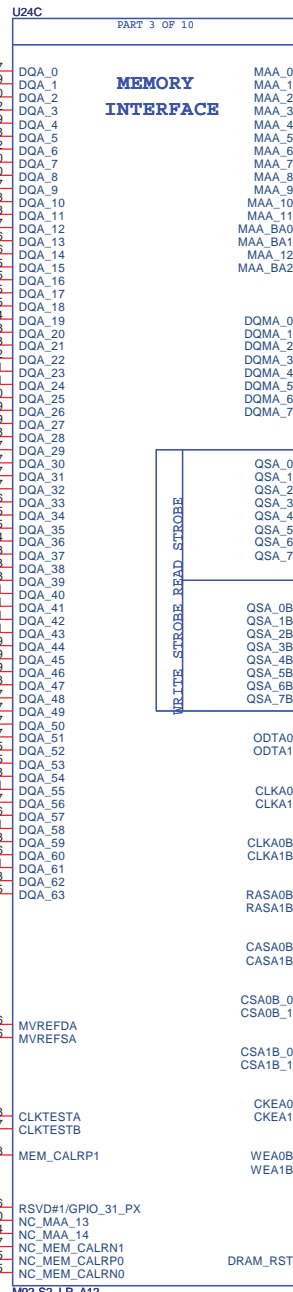
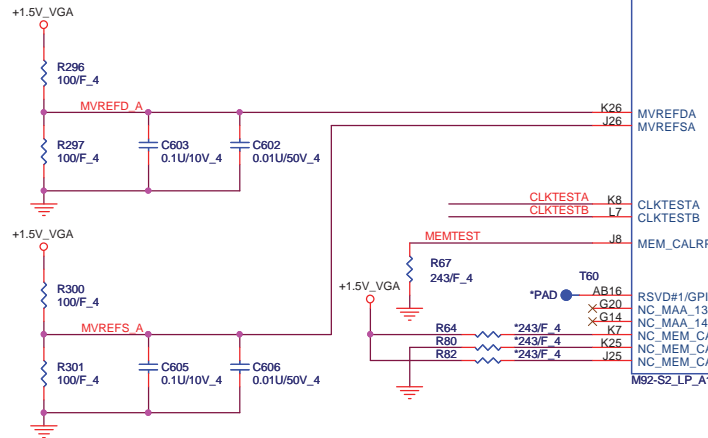

# THERMAL MONITOR

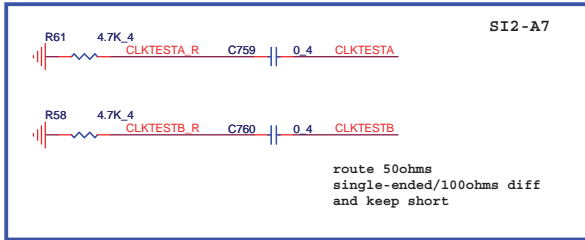
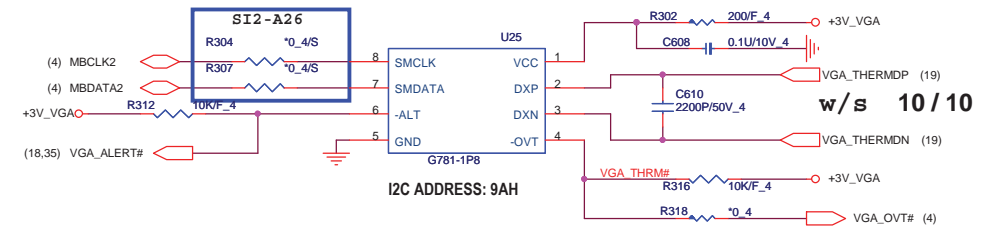

route 50ohms single-ended/100ohms diff and keep short

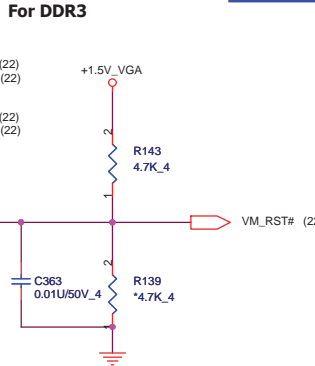

**PROJECT : SP6**  
**Quanta Computer Inc.**

Size Custom	Document Number <b>M92 Memory/Thermal</b>	Rev 1A
Date: Tuesday, April 07, 2009   Sheet 16 of 49		



# TMDP(HDMI) INTERFACE

(15,18,19,20,40) +1.1V

# LVDS INTERFACE

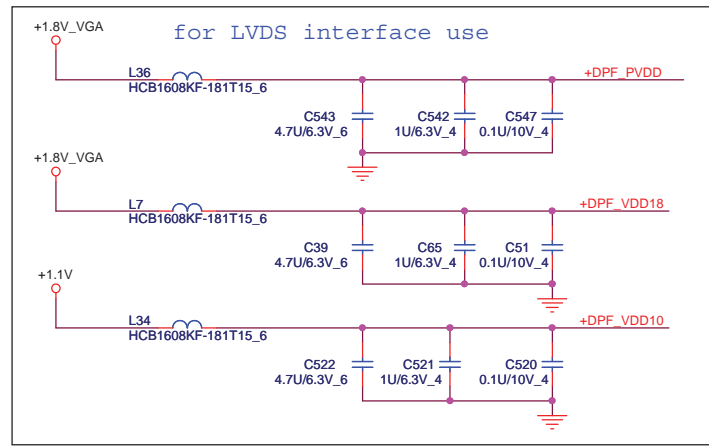
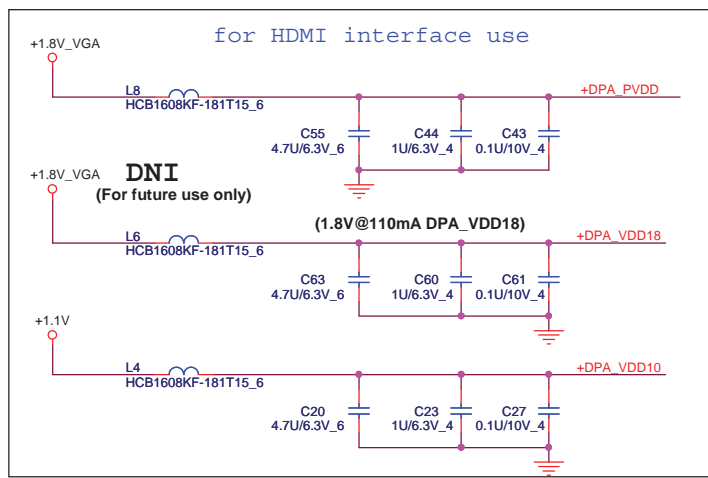
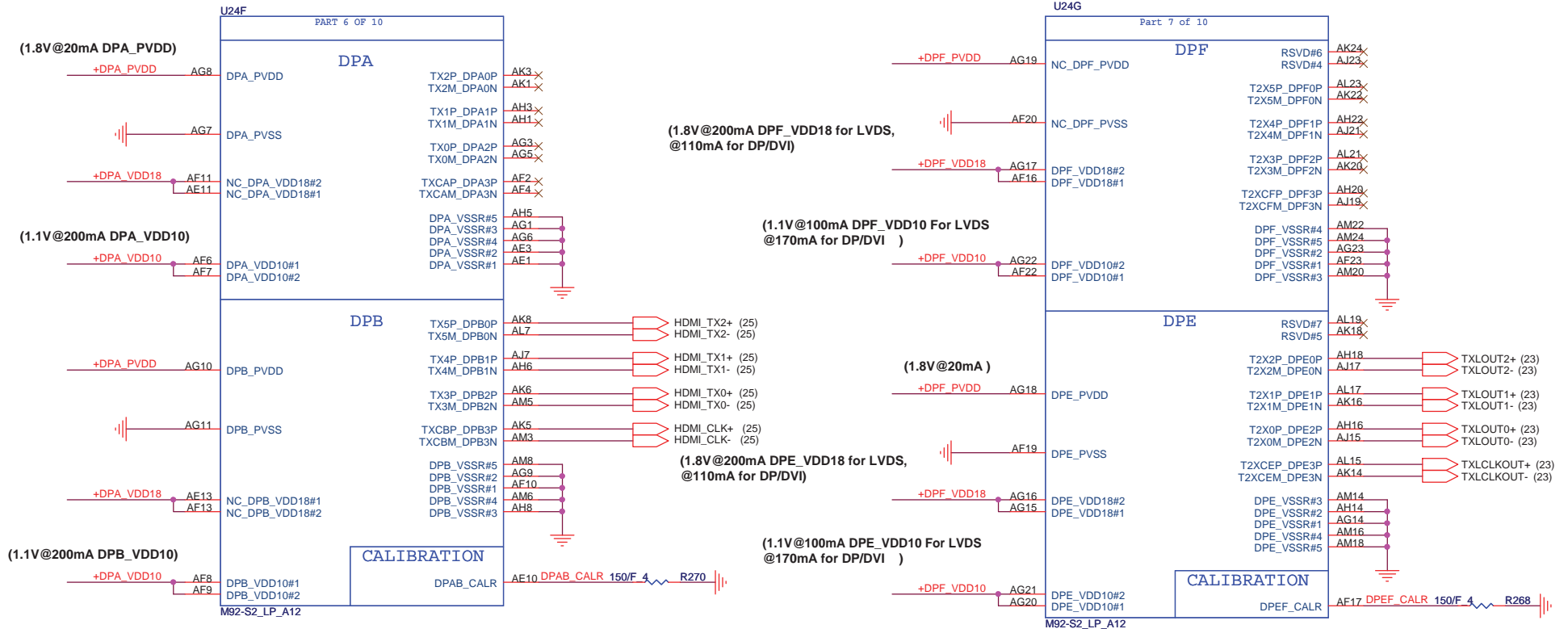

<p>NBS</p>	<p><b>PROJECT : SP6</b> Quanta Computer Inc.</p>		<p>Rev 1A</p>
	<p>Size B</p>	<p>Document Number <b>M92 HDMI/LVDS interface</b></p>	

Sheet 17 of 49

MEMORY SIZE	CFG3 GPIO9	CFG2 GPIO13	CFG1 GPIO12	CFG0 GPIO11
128MB	0	0	0	0
256MB	0	0	1	1
64MB	0	1	0	0
512MB	1	0	0	0

Default

Memory Straps	DDR3	RAM_TYPE_CFG3	RAM_TYPE_CFG2	RAM_TYPE_CFG1	RAM_TYPE_CFG0
667MHz K4W1G1646D-EC15 (64M*16) Samsung	X	X	0	1	
700MHz H5TQ1G63BFR-14C (64M*16) Hynix	X	X	0	0	
Blank	X	X	0	0	
Blank	X	X	0	0	

GPIO Straps table	DESCRIPTION OF DEFAULT SETTINGS	SP6 setting
GPIO0	GPIO0 - TX_PWR5_ENB (Transmitter Power Savings Enable) 0: 50% Tx output swing for mobile mode 1: full Tx output swing (Default setting for Desktop)	1
GPIO1	GPIO1 - TX_DEEMPH_EN (Transmitter De-emphasis Enable) 0: Tx de-emphasis disabled for mobile mode 1: Tx de-emphasis enabled (Default setting for Desktop)	1
GPIO2	GPIO2 - BUF_GENZ_EN (5.0 GOhm Enable) 0: Default (Driver Controlled GenZ) 1: Strap Controlled GenZ	0
GPIO3	ATI reserved configuration straps.	0
GPIO4	ATI reserved configuration straps.	0
GPIO5	GPIO 5 AC_BATT 0: Battery saving mode = 0.0 V 1: AC (Performance mode) = 3.3 V	0
GPIO6	ATI Internal use only	0

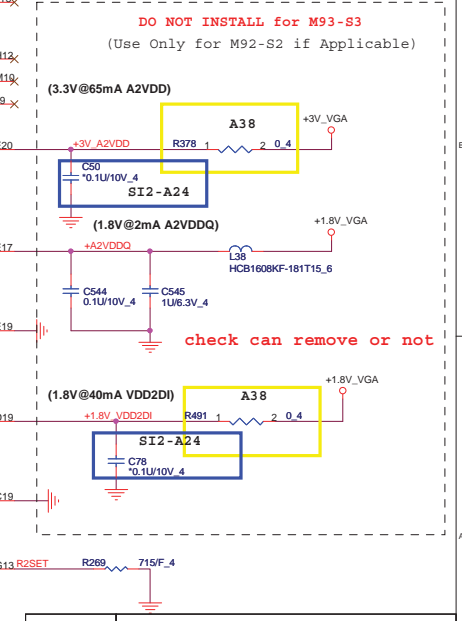
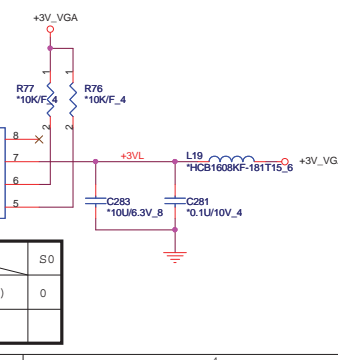
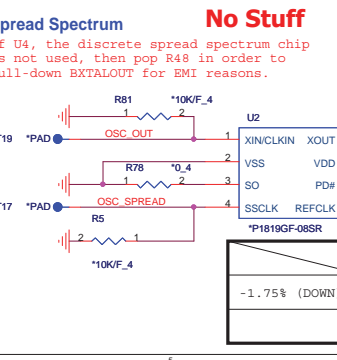
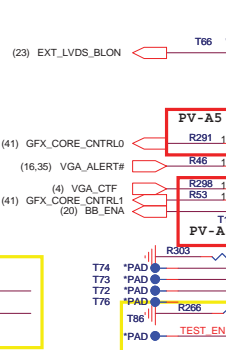
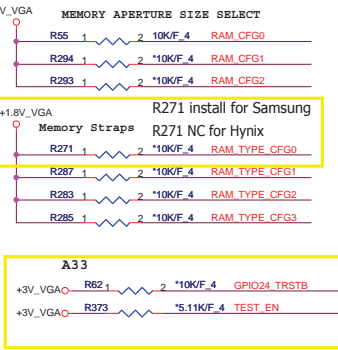
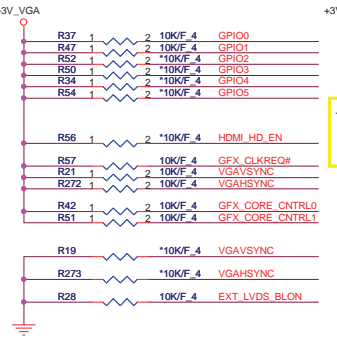
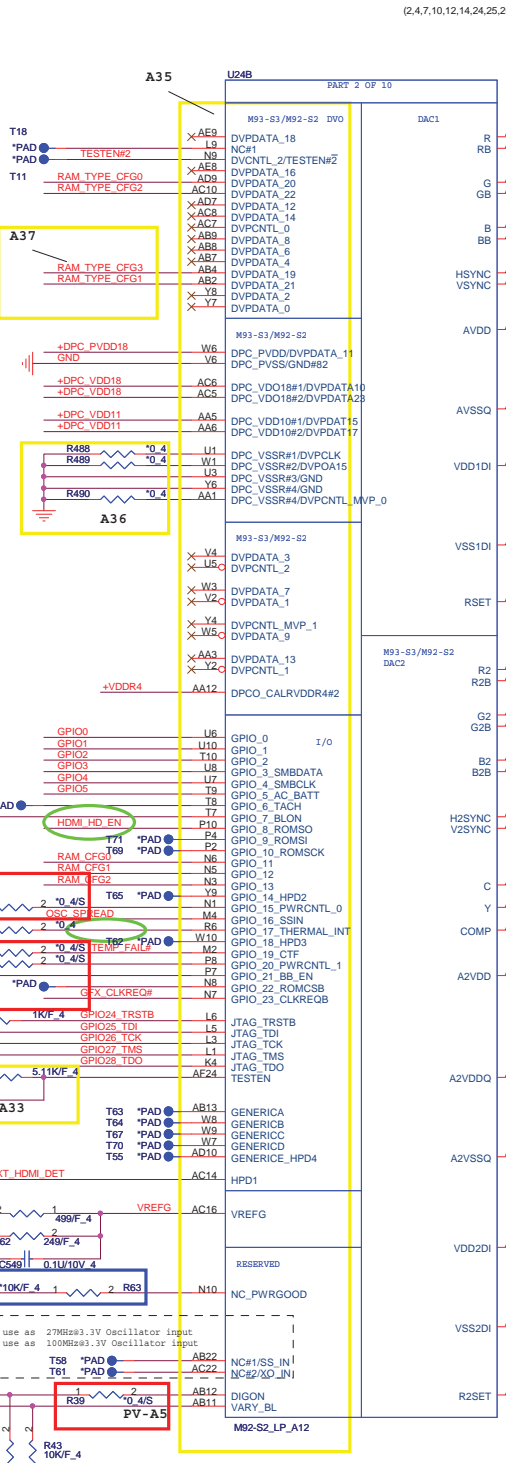
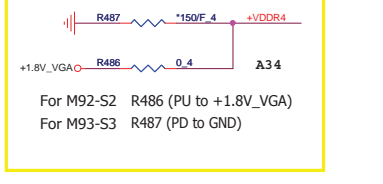
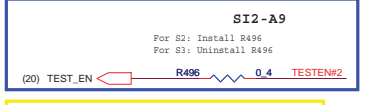
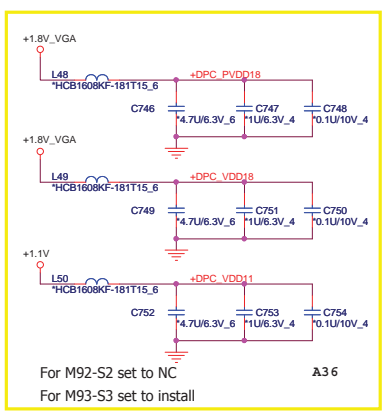

**PROJECT : SP6**  
**Quanta Computer Inc.**

Size Custom Document Number M92 IO/GPIO Rev 2A

Date: Tuesday, April 07, 2009 Sheet 18 of 49

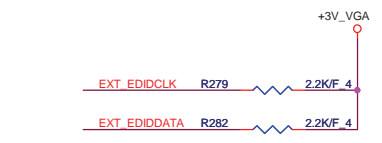
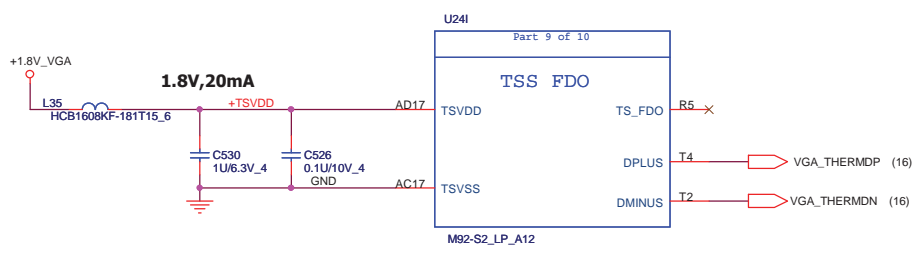
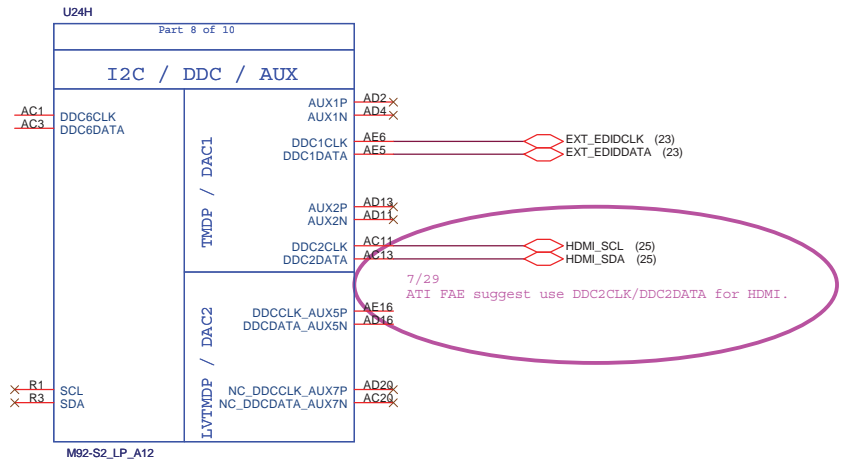
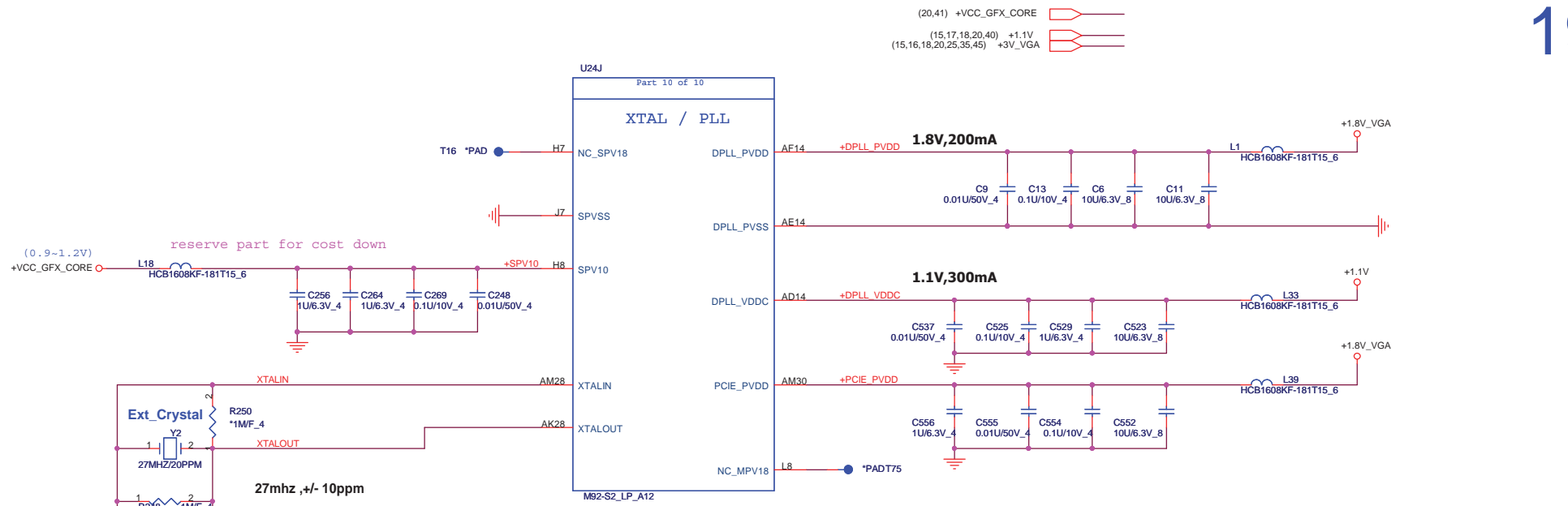

HDMI



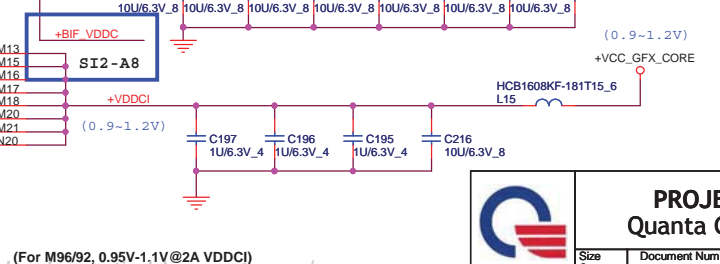
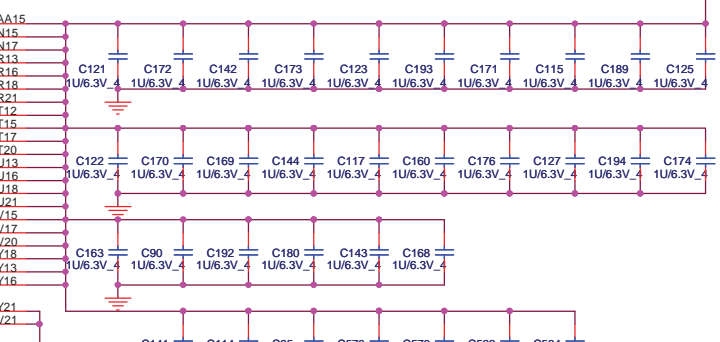
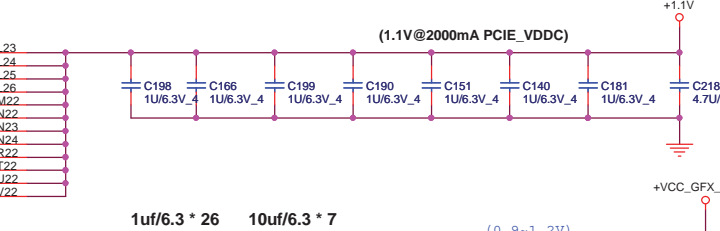
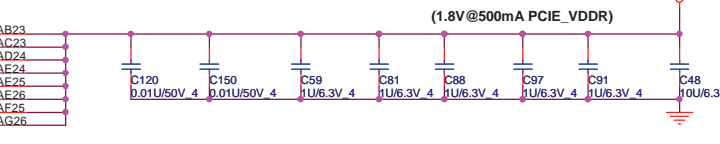
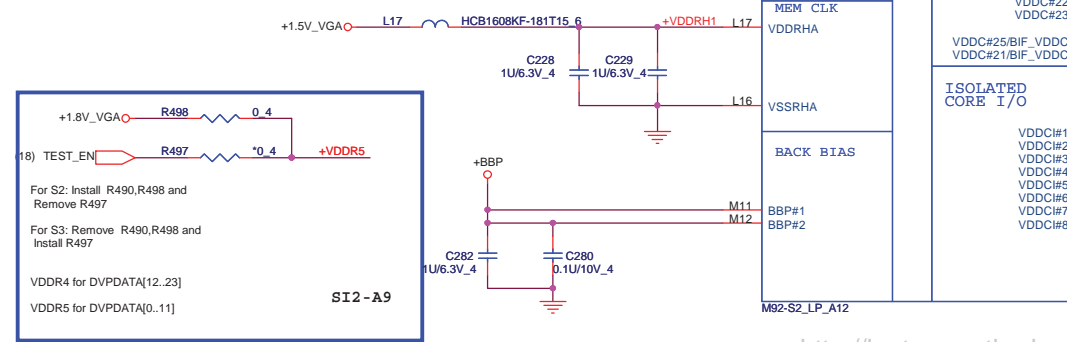
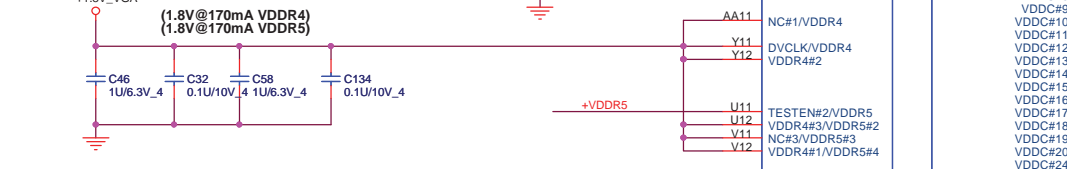
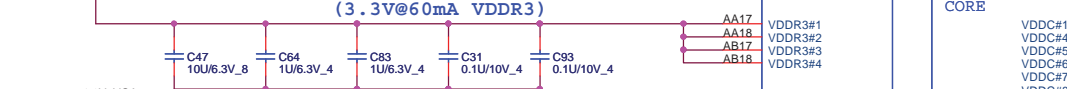
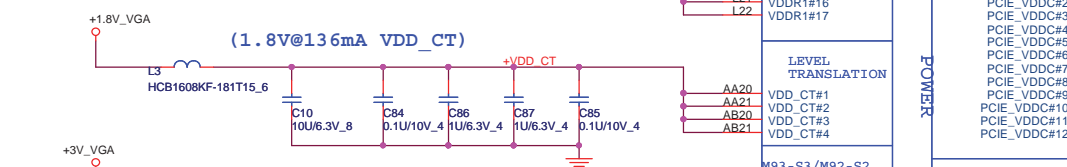
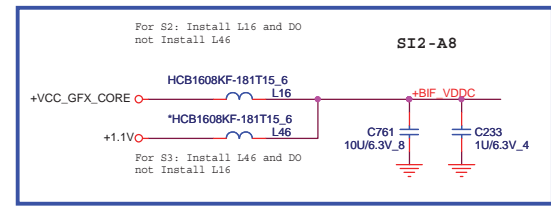
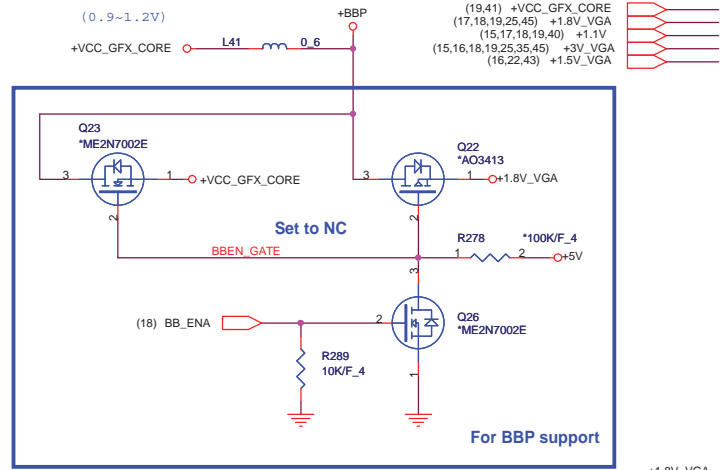
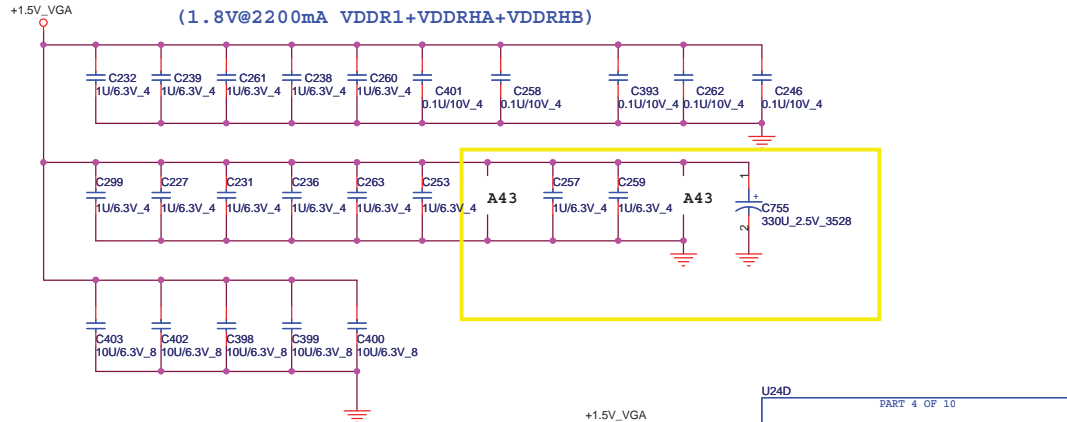

U24D PART 4 OF 10

MEM I/O	
H13	VDDR1#1
H16	VDDR1#2
H19	VDDR1#3
J10	VDDR1#4
J23	VDDR1#5
J24	VDDR1#6
J9	VDDR1#7
K10	VDDR1#8
K23	VDDR1#9
K9	VDDR1#10
L11	VDDR1#11
L12	VDDR1#12
L13	VDDR1#13
L20	VDDR1#14
L21	VDDR1#15
L22	VDDR1#16
LEVEL TRANSLATION	
AA20	VDD_CT#1
AA21	VDD_CT#2
AA20	VDD_CT#3
AA21	VDD_CT#4
M93-S3/M92-S2	
AA17	VDDR3#1
AA18	VDDR3#2
AA17	VDDR3#3
AA18	VDDR3#4
NC#1/VDDR4	
Y11	DVCLK/VDDR4
Y12	VDDR4#2
TESTEN#2/VDDR5	
U11	VDDR4#3/VDDR5#2
U12	VDDR4#3/VDDR5#2
V11	NC#3/VDDR5#3
V12	VDDR4#1/VDDR5#4
MEM CLK	
L17	VDDRHA
VSSRHA	
L16	VSSRHA
BACK BIAS	
M11	BBP#1
M12	BBP#2
M92-S2_LP_A12	

(For M96/92, 0.95V-1.1V@2A VDDCI)

<http://laptop-motherboard-schematic.blogspot.com/>



PROJECT : SP6  
Quanta Computer Inc.

Size Custom	Document Number M92 POWER/GND	Rev 2B
Date: Tuesday, April 07, 2009		Sheet 20 of 49

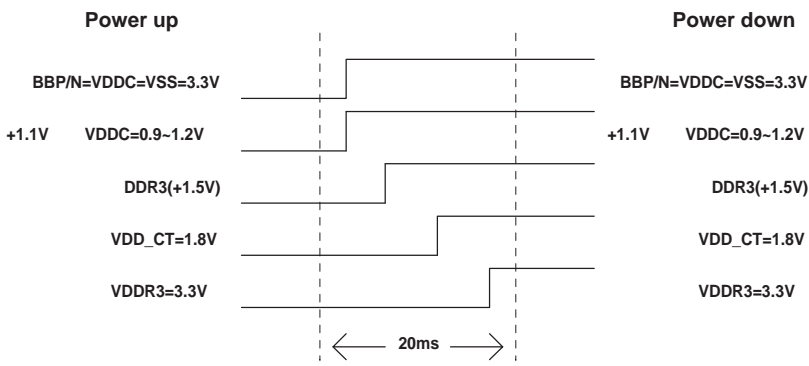
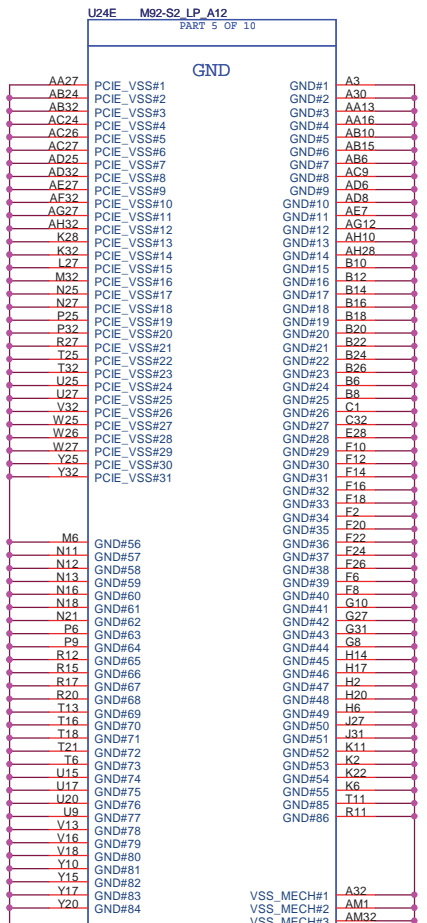

CONFIGURATION STRAPS			RECOMMENDED SETTINGS 0= DO NOT INSTALL RESISTOR 1= INSTALL 10K RESISTOR X= DESIGN DEPENDANT NA= NOT APPLICABLE
ALLOW FOR PULLUP PADS FOR THESE STRAPS AND IF THESE GPIOs ARE USED, THEY MUST NOT CONFLICT DURING RESET			
STRAPS	PIN	DESCRIPTION OF DEFAULT SETTINGS	
TX_PWRS_ENB	GPIO0	PCIE FULL TX OUTPUT SWING	X
TX_DEEMPH_EN	GPIO1	PCIE TRANSMITTER DE-EMPHASIS ENABLED	X
BIF_GEN2_EN_A	GPIO2	PCIE GEN2 ENABLED	X
RSVD	GPIO8		0
BIF_VGA_DIS	GPIO9	VGA ENABLED	0
RSVD	GPIO21		0
BIOS_ROM_EN	GPIO_22_ROMCSB	ENABLE EXTERNAL BIOS ROM	X
ROMIDCFG(2:0)	GPIO[13:11]	SERIAL ROM TYPE OR MEMORY APERTURE SIZE SELECT	X X X
VIP_DEVICE_STRAP_ENA	V2SYNC	IGNORE VIP DEVICE STRAPS	X
RSVD	GENERICC		0
AUD[1]	HSYNC	AUD[1] AUD[0]	0
AUD[0]	VSYN	0 0 No audio function 0 1 Audio for DisplayPort and HDMI if dongle is detected 1 0 Audio for DisplayPort only 1 1 Audio for both DisplayPort and HDMI	X X

**PROJECT : SP6**  
Quanta Computer Inc.

Size Custom Document Number M92-S2-LP\_G\_GND Rev 1A

Date: Tuesday, April 07, 2009 Sheet 21 of 49

# 512MB DDR3

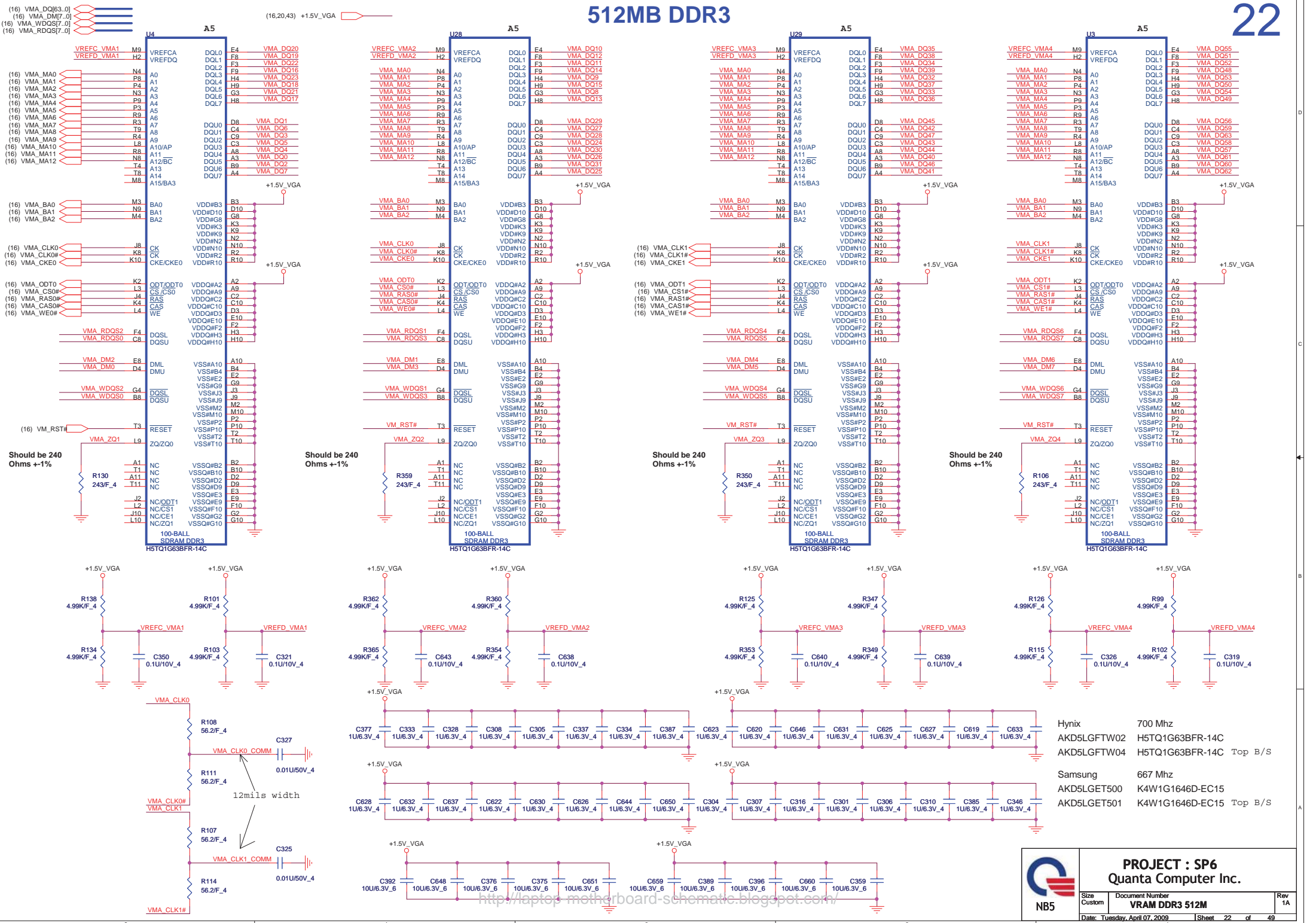

**PROJECT : SP6**

**Quanta Computer Inc.**

Size	Document Number	Rev
Custom	<b>VRAM DDR3 512M</b>	1A
Date: Tuesday, April 07, 2009		Sheet 22 of 49

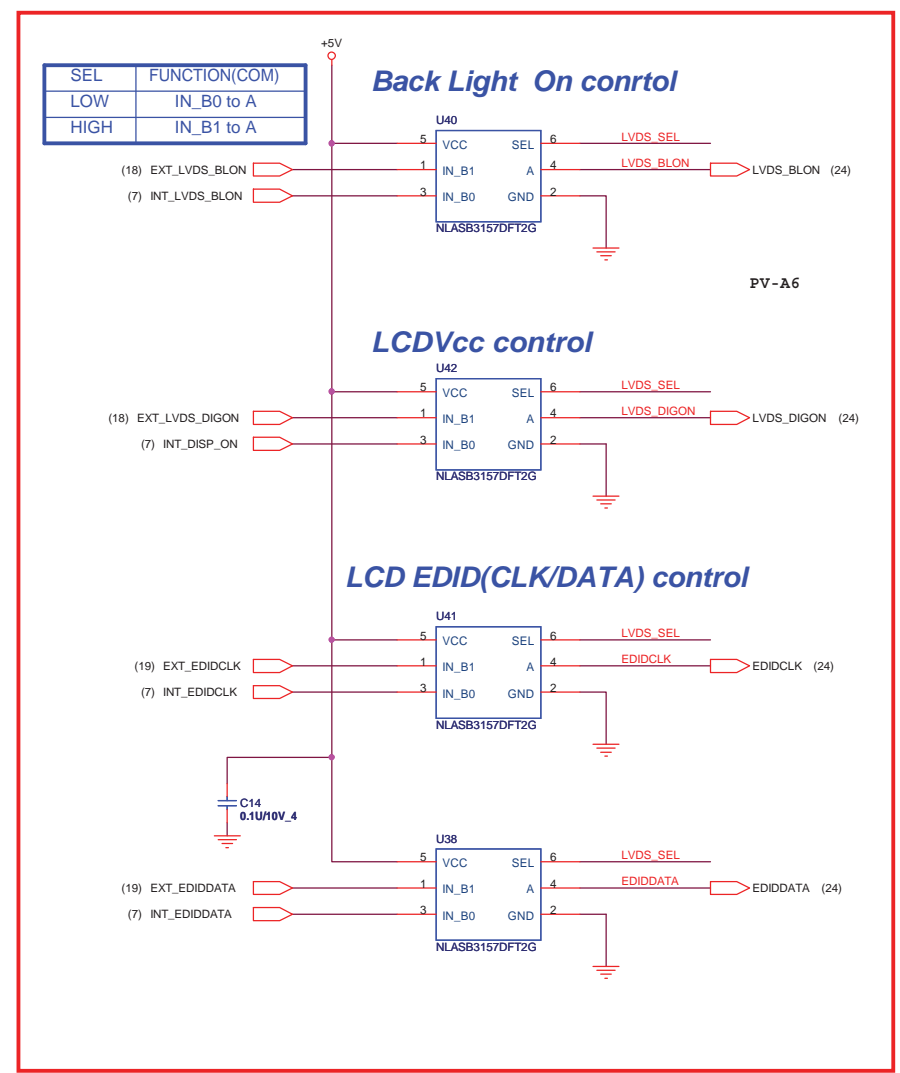
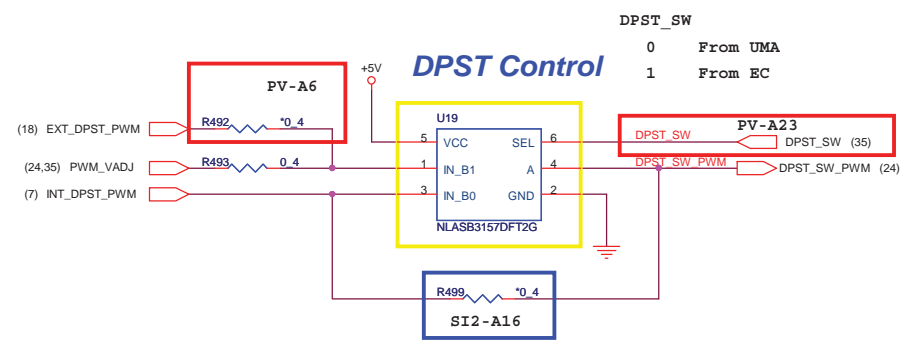
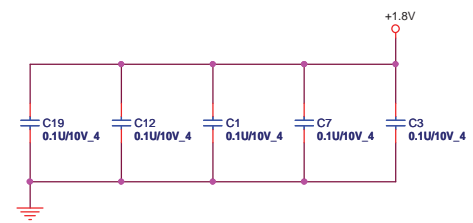
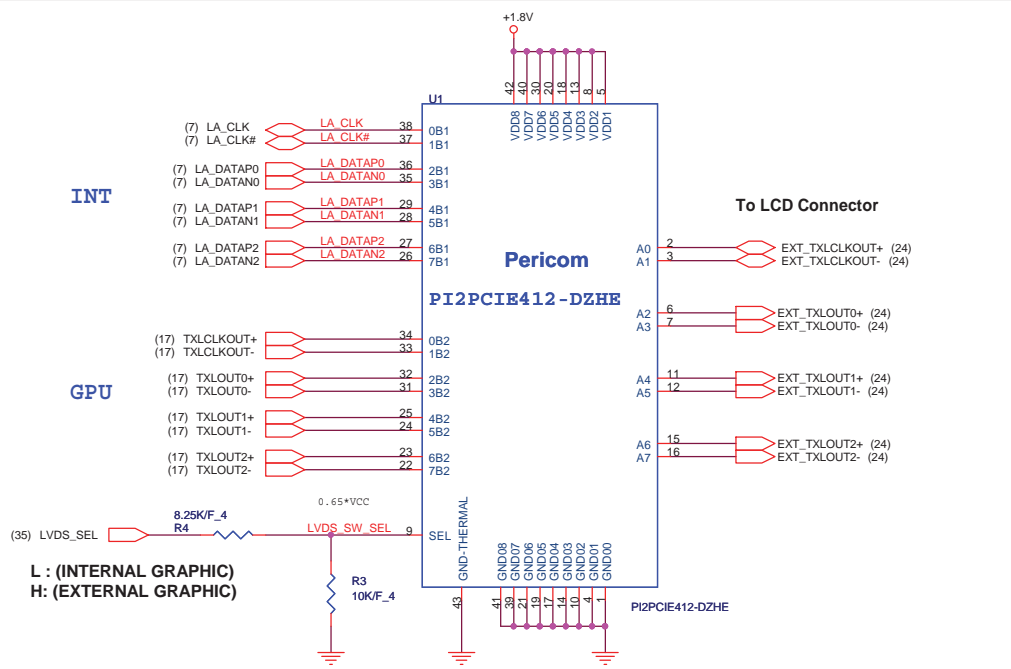

# USB CAMERA /DIGITAL MIC CONNECT

(2,4,7,10,12,14,25,26,27,28,29,30,31,32,33,34,35,36,45)  
 +3V (20,23,25,29,31,36,45)  
 +5V (37,39,40,41,42,43,44,45)  
 +VIN (26,32,33,35,37,38,39,43,44,45)  
 +3VPCU

$V_{out} = 1.25 (1 + R1/R2)$

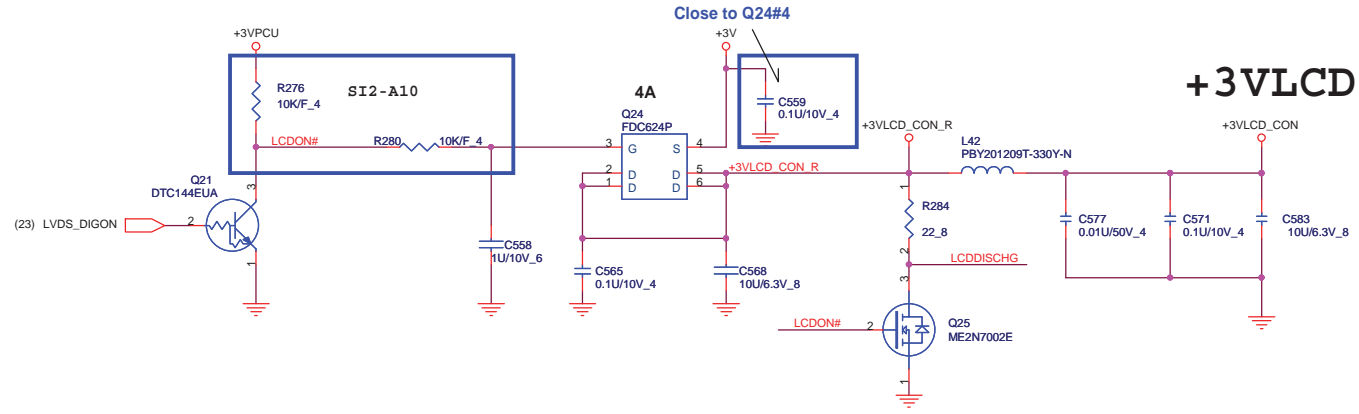
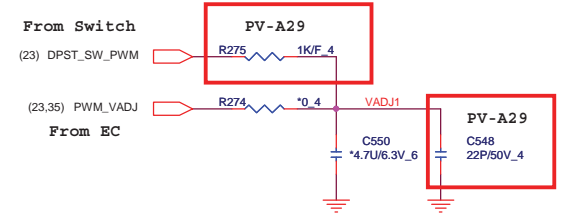
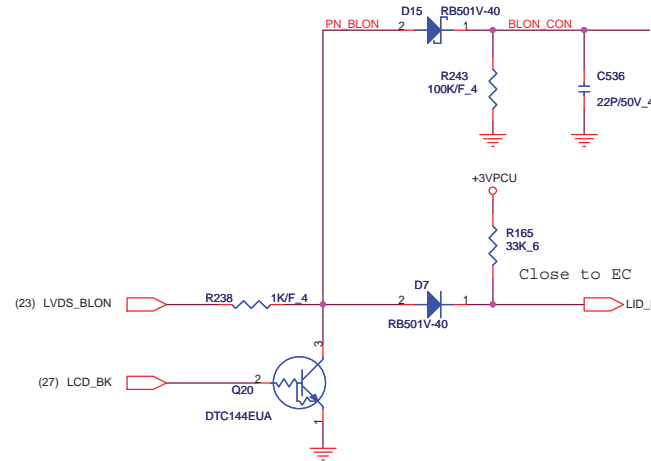
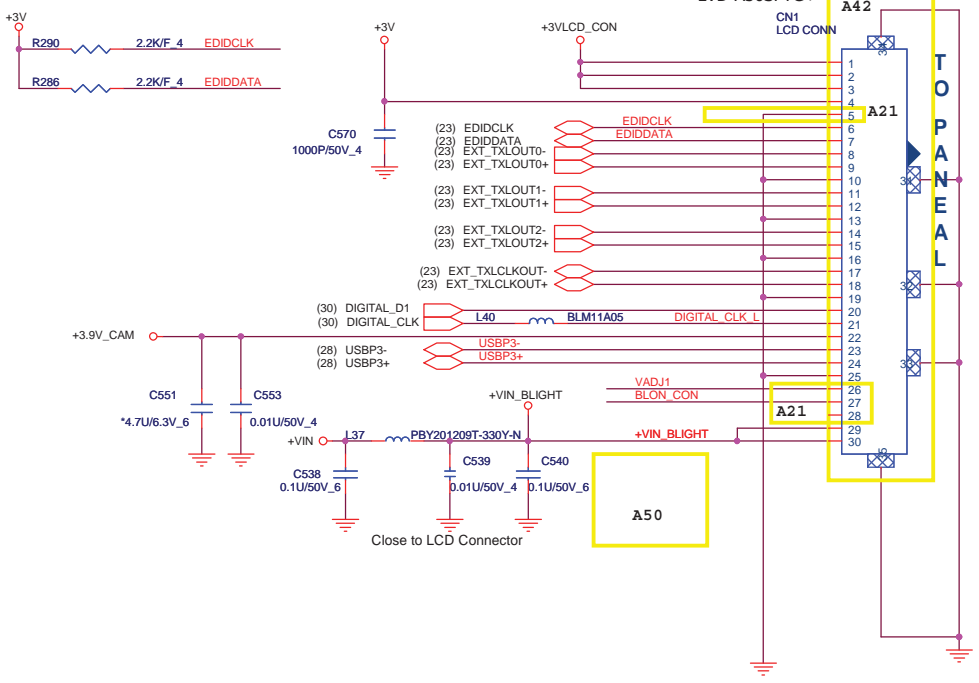
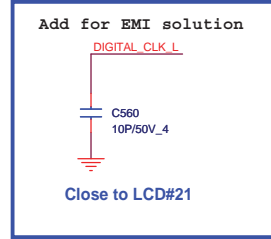
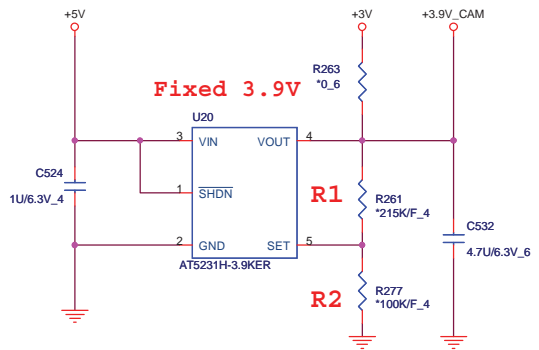

	<b>PROJECT : SP6</b> Quanta Computer Inc.	
	Size Custom	Document Number <b>LVDS/Camera/Digital MIC</b>
Date: Tuesday, April 07, 2009		Sheet 24 of 49



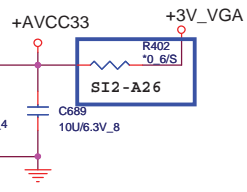
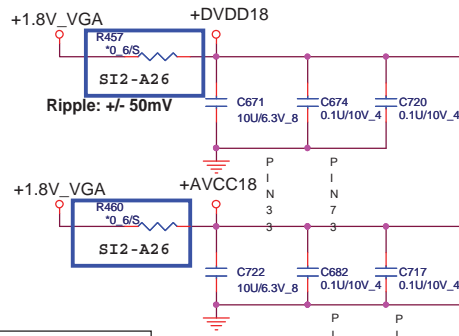

HPDIN

STATE	Status
LOW	Without HDMI Device
HIGH	HDMI Device detect

(TPWR/I2CADDR)

STATE	ADDRESS
LOW	0xC0/0xD0/0xE0 (DEFAULT)
HIGH	0xC4/0xD4/0xE4

PLACE AC CAPS CLOSE TO CONNECTOR



SI9181

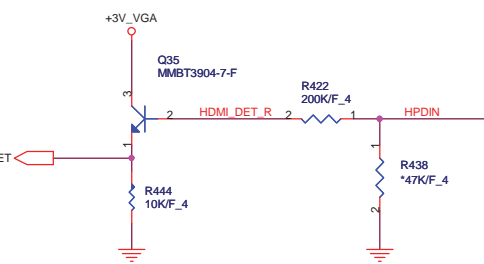
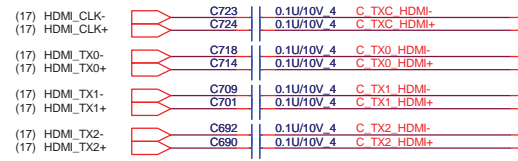

MAKE SURE THE MOSFET IS OFF DURING SYSTEM IN STANDBY

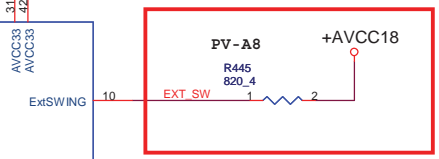
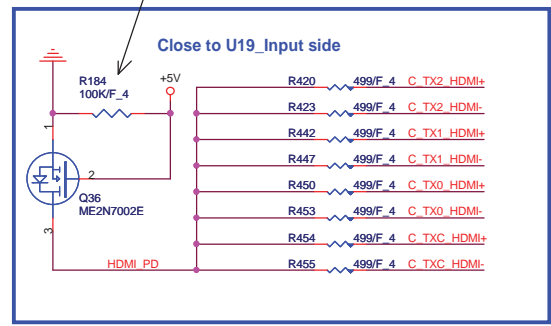

HDMI PORT

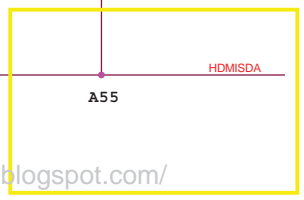
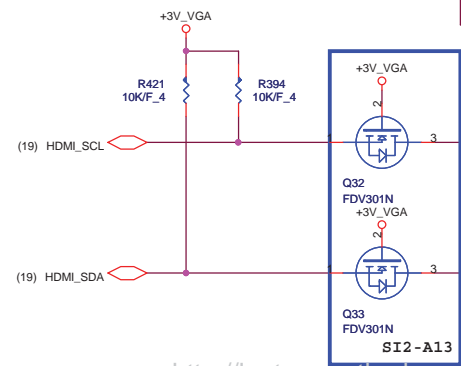
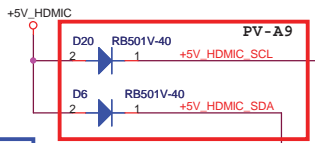
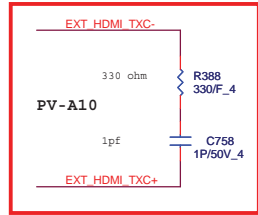
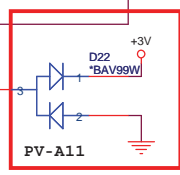
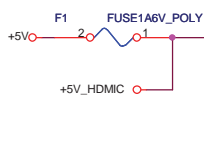
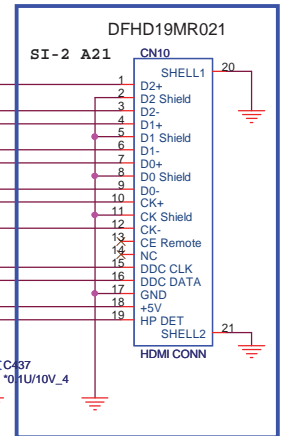

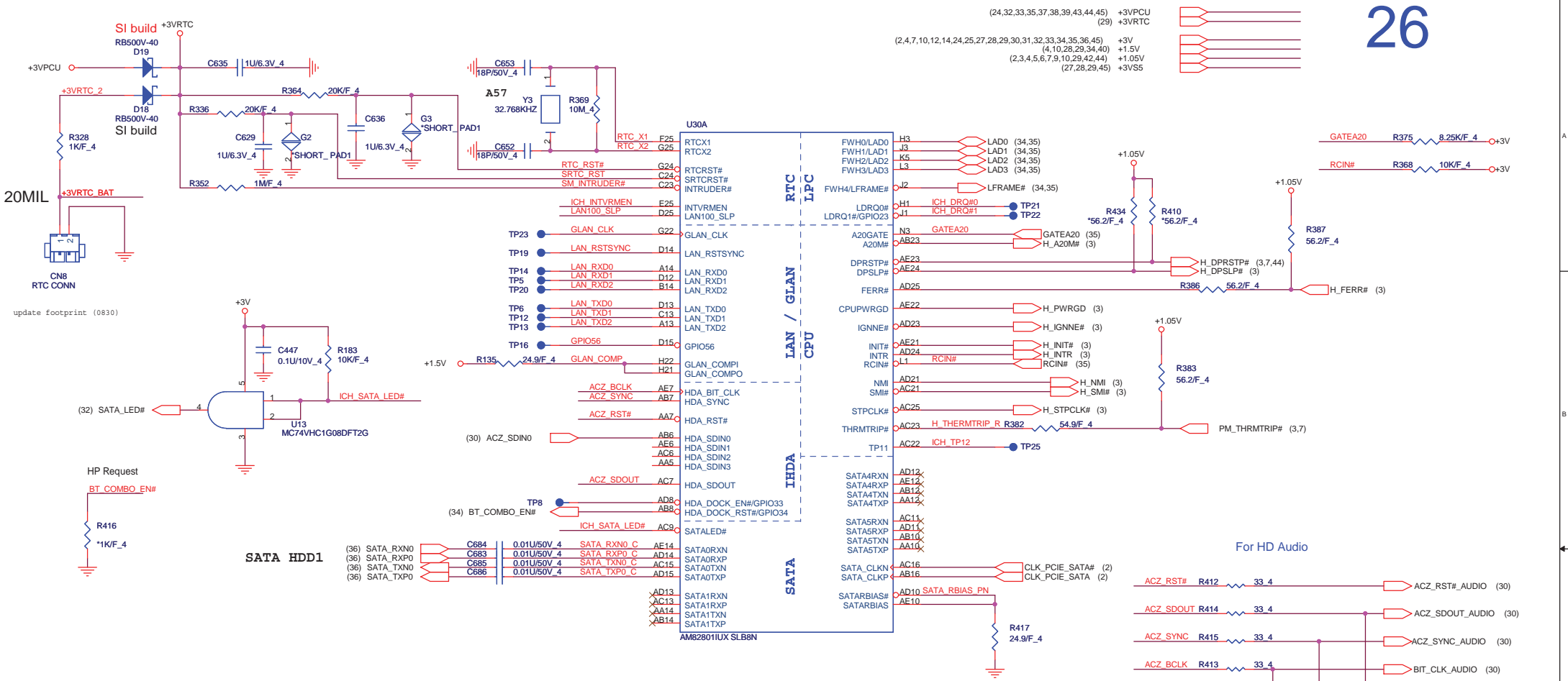

## SB Strap

**ICH9-M Internal VR Enable strap**  
 (Internal VR for VccSus1\_05, VccSus1\_5 and VccCL1\_5)

**ICH9-M LAN100\_SLP Strap**  
 (Internal VR for VccLAN1\_05 and VccCL1\_05)

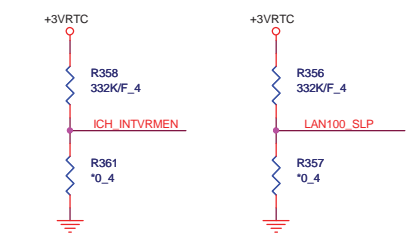

**XOR Chain Entrance Strap**

ICH_TP3	HDA_SDOOUT	Description
0	0	RSVD
0	1	Enter XOR Chain
1	0	Normal operation(Default)
1	1	Set PCIe port config bit 1

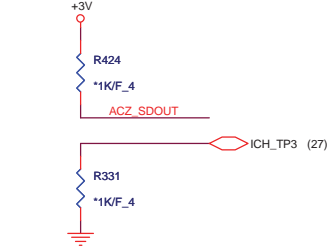

**ICH9 Boot BIOS select**

STRAP	PCI_GNT0#	SPI_CS#1
SPI	0	1
PCI	1	0
LPC	1	1

(default)

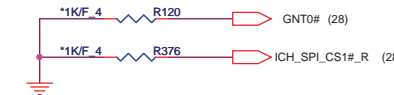

**A16 swap override strap**

PCI_GNT#3	Low = A16 swap override enabled	Hi = Default
-----------	---------------------------------	--------------

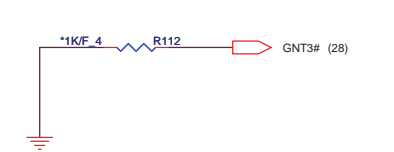

**No Reboot Strap**

ACZ_SPKR	Low: Default	Hi: No reboot
----------	--------------	---------------

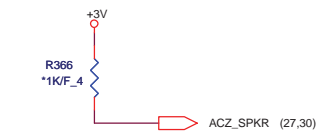

**TPM physical presence**

ICH_GPIO57	Low: Default
------------	--------------

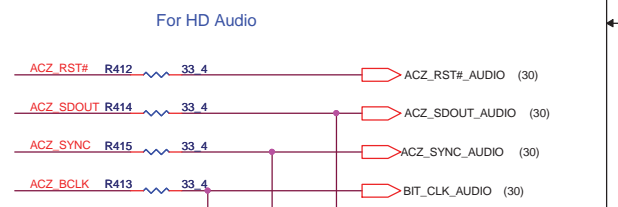
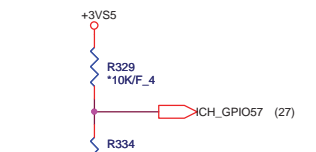

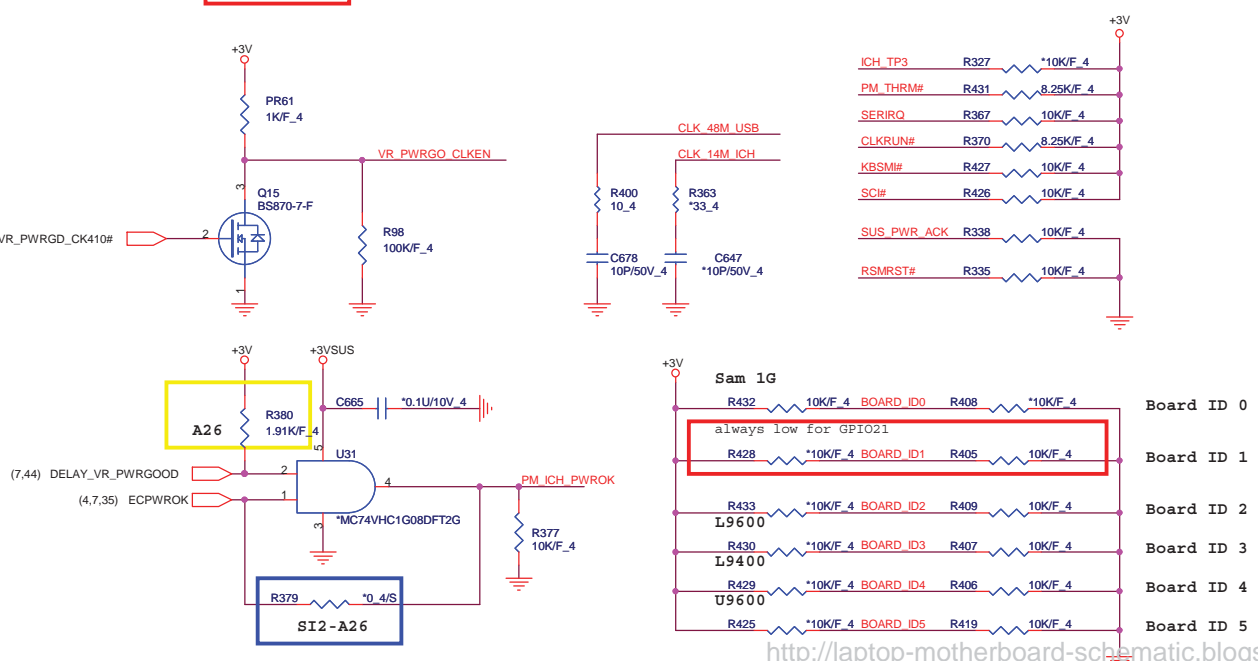
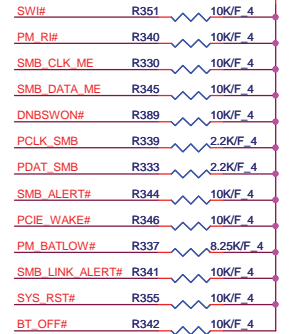
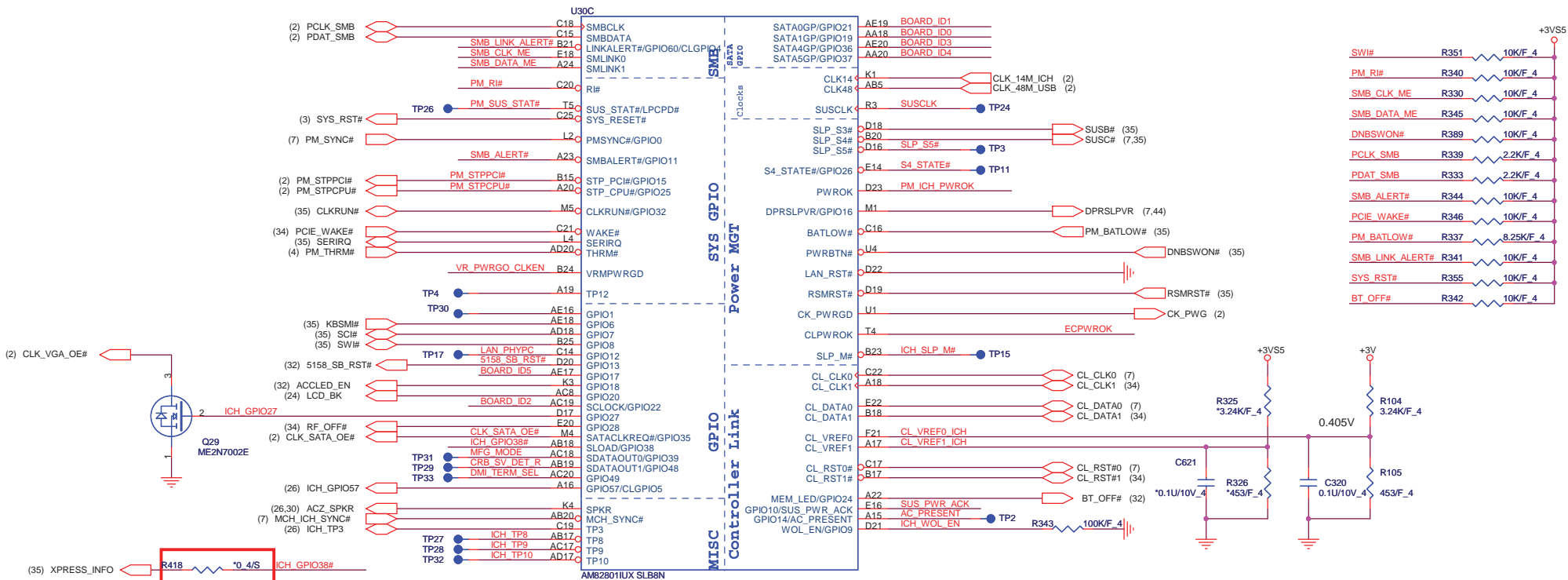

**PV Update Board ID table**

	Memory Select			CPU Select		
	Board ID 0 GPIO19	Board ID 1 GPIO21	Board ID 2 GPIO22	Board ID 3 GPIO36	Board ID 4 GPIO37	Board ID 5 GPIO17
RESERVE	0	0	0	0	0	0
Samsung 1G	1	0	0	0	0	0
RESERVE	0	0	0	0	0	0
RESERVE	0	0	0	0	0	0
L9600 2.13G	0	0	0	1	0	0
L9400 1.86G	0	0	0	0	1	0
U9600 1.6G	0	0	0	0	0	1

**PROJECT : SP6**  
**Quanta Computer Inc.**

Size Custom Document Number ICH9 (PM/GPIO) Rev 1A  
 Date: Tuesday, April 07, 2009 Sheet 27 of 49

Place TX DC blocking caps close ICH9.

WLAN

- (34) PCIE\_RXN0
- (34) PCIE\_RXP0
- (34) PCIE\_TXN0
- (34) PCIE\_TXP0

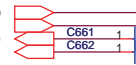

Delete R121, R378 due have the same pd in page 26

A3

U30D

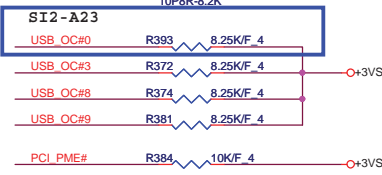
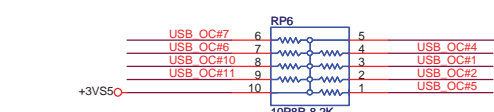
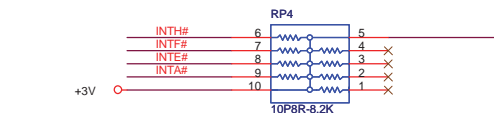
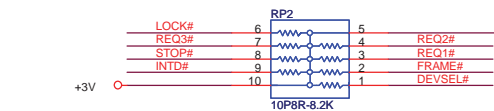
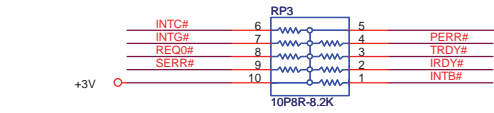
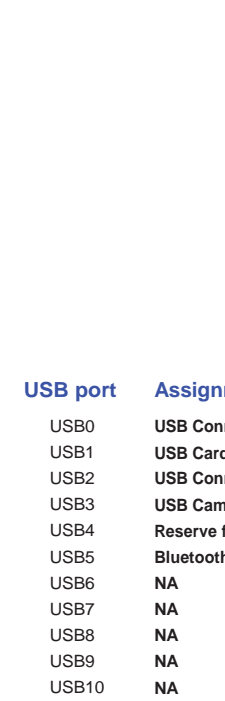
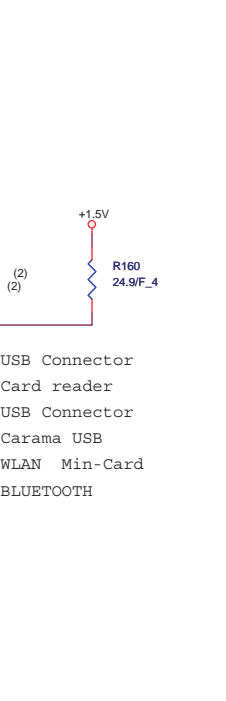
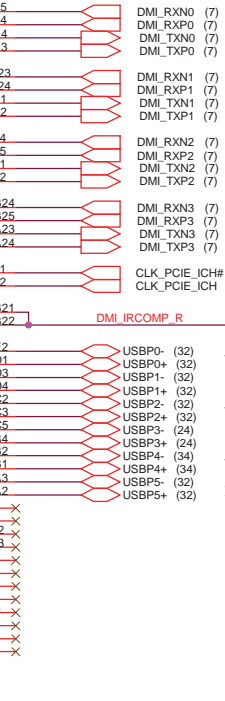
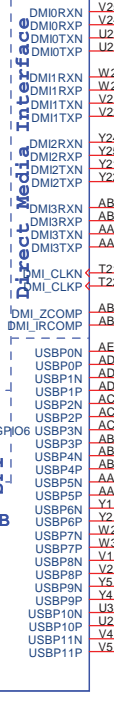
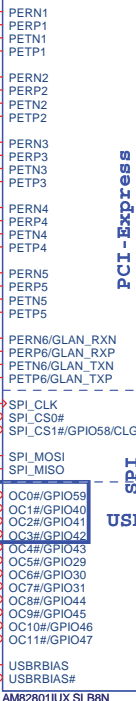

A14 R373 delete

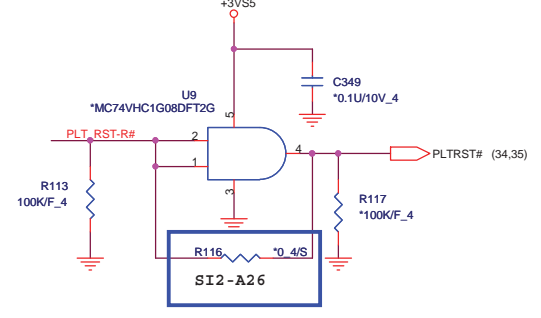
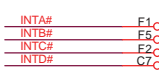

USB port	Assignment function
USB0	USB Connector
USB1	USB Card reader
USB2	USB Connector
USB3	USB Camera module
USB4	Reserve for Mini Card
USB5	Bluetooth
USB6	NA
USB7	NA
USB8	NA
USB9	NA
USB10	NA
USB11	NA

**PROJECT : SP6**  
**Quanta Computer Inc.**

Size Custom Document Number ICH9 (USB/PCIE/DMI) Rev 1A

Date: Tuesday, April 07, 2009 Sheet 28 of 49

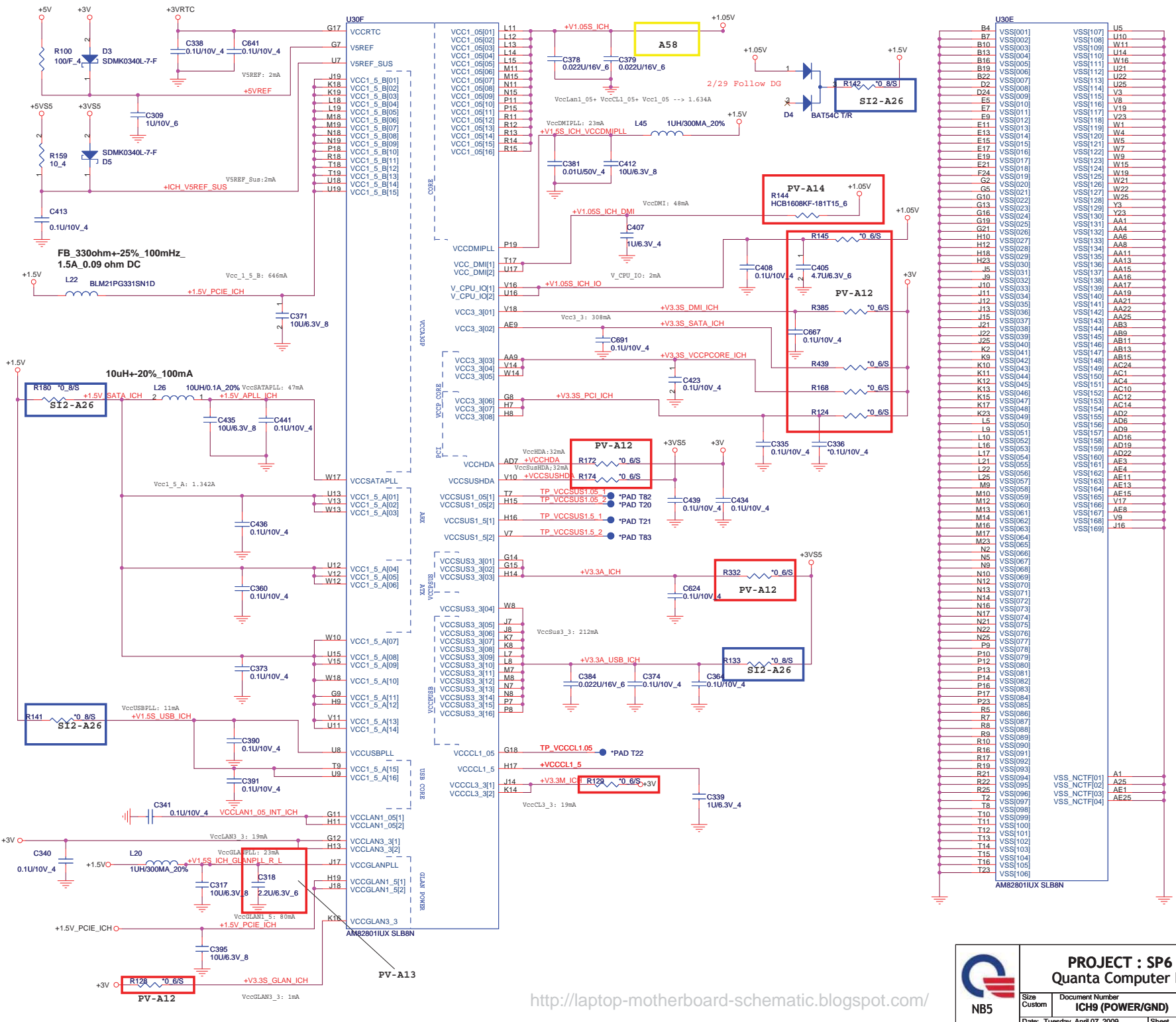

<http://laptop-motherboard-schematic.blogspot.com/>

	<b>PROJECT : SP6</b> <b>Quanta Computer Inc.</b>	
	Size Custom Document Number <b>ICH9 (POWER/GND)</b>	Rev <b>1A</b>
Date: Tuesday, April 07, 2009		Sheet 29 of 49

PORT	PLACE TO
MONO_OUT	X
PORT A	HP OUT
PORT B	External MIC
PORT C	X
PORT D	Internal Speckers
DM	DIGITAL MIC

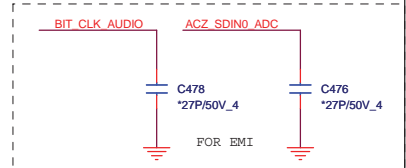
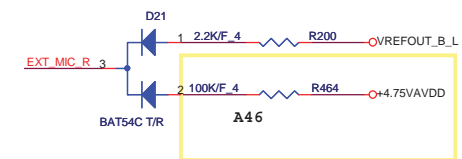
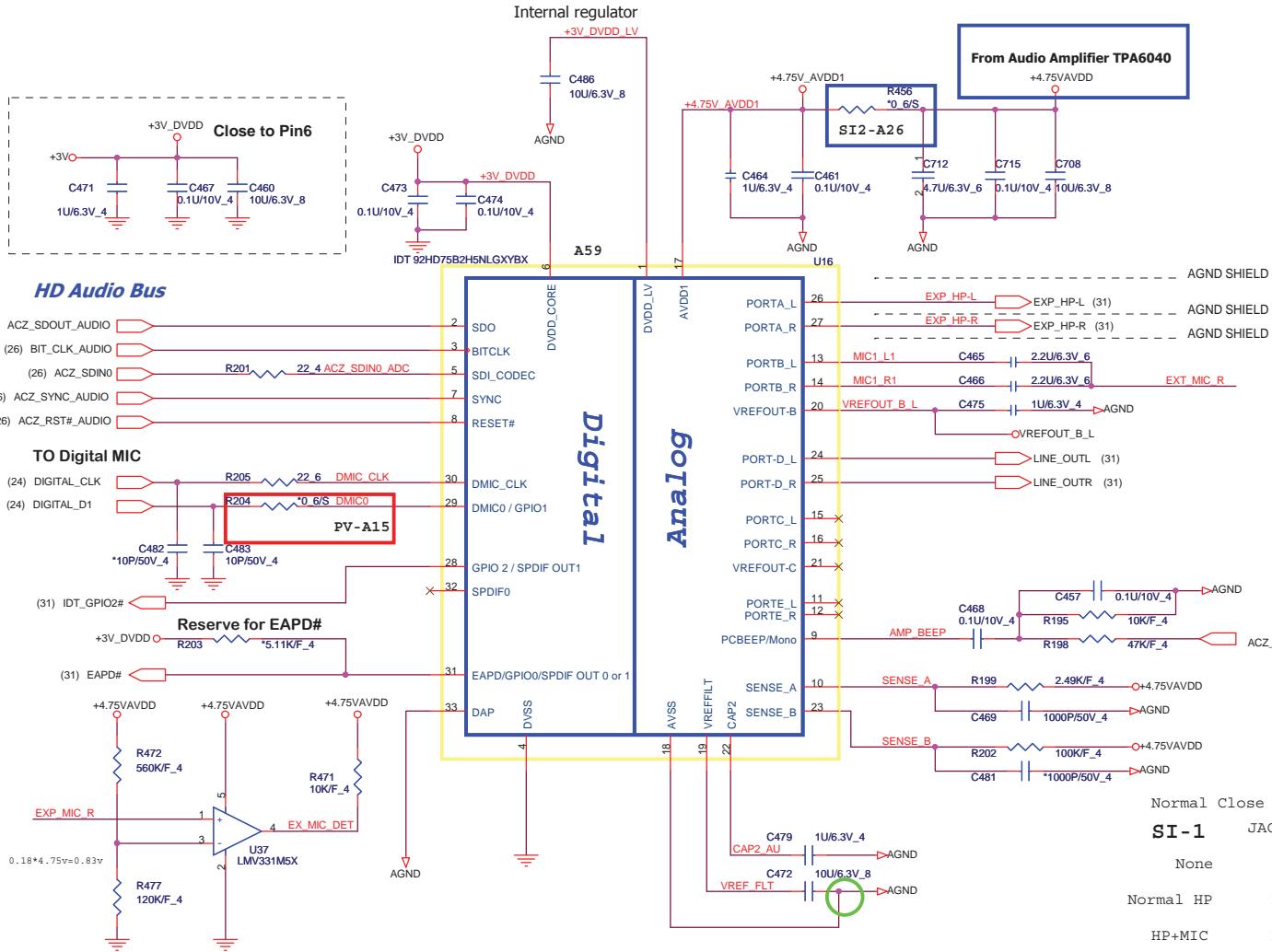

SA\_A# -->Headphone out  
SA\_B# -->EXT MIC

Normal Close	JACK_SEN#	EX_MIC_DET
None	Low	HIGH
Normal HP	HIGH	Low
HP+MIC	HIGH	HIGH

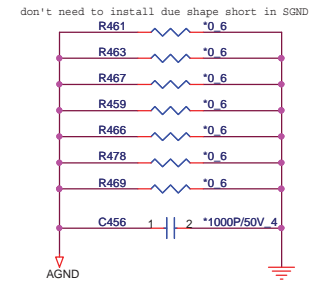

Combo Jack (Headphone/MIC)

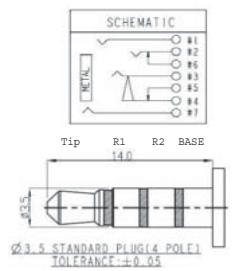
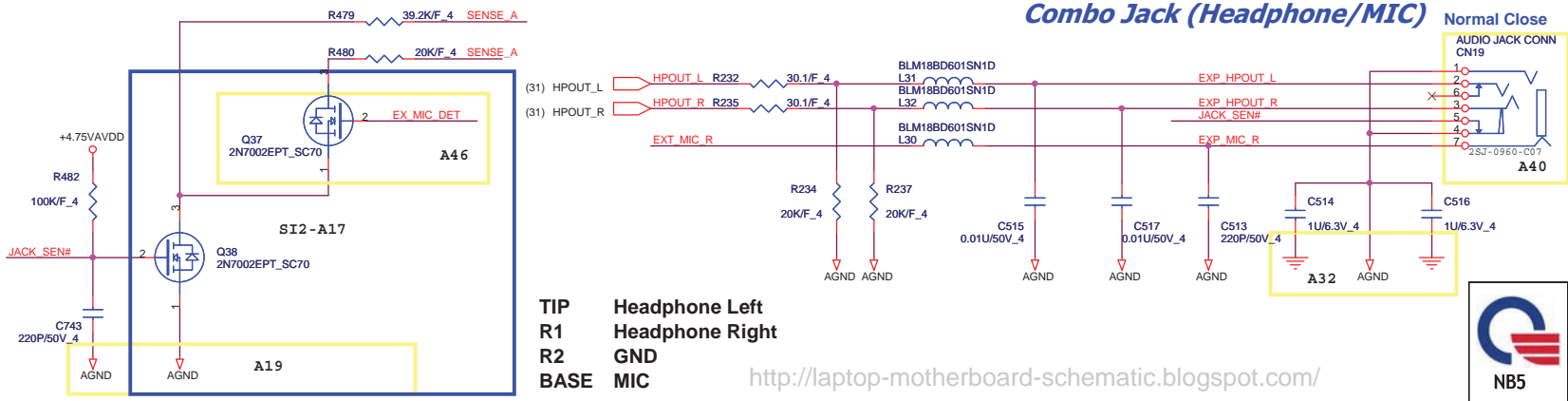

TIP Headphone Left  
R1 Headphone Right  
R2 GND  
BASE MIC

<http://laptop-motherboard-schematic.blogspot.com/>



PROJECT : SP6  
Quanta Computer Inc.

# AUDIO AMPLIFIER

Swap Audio input source as Speaker Bo noise issue

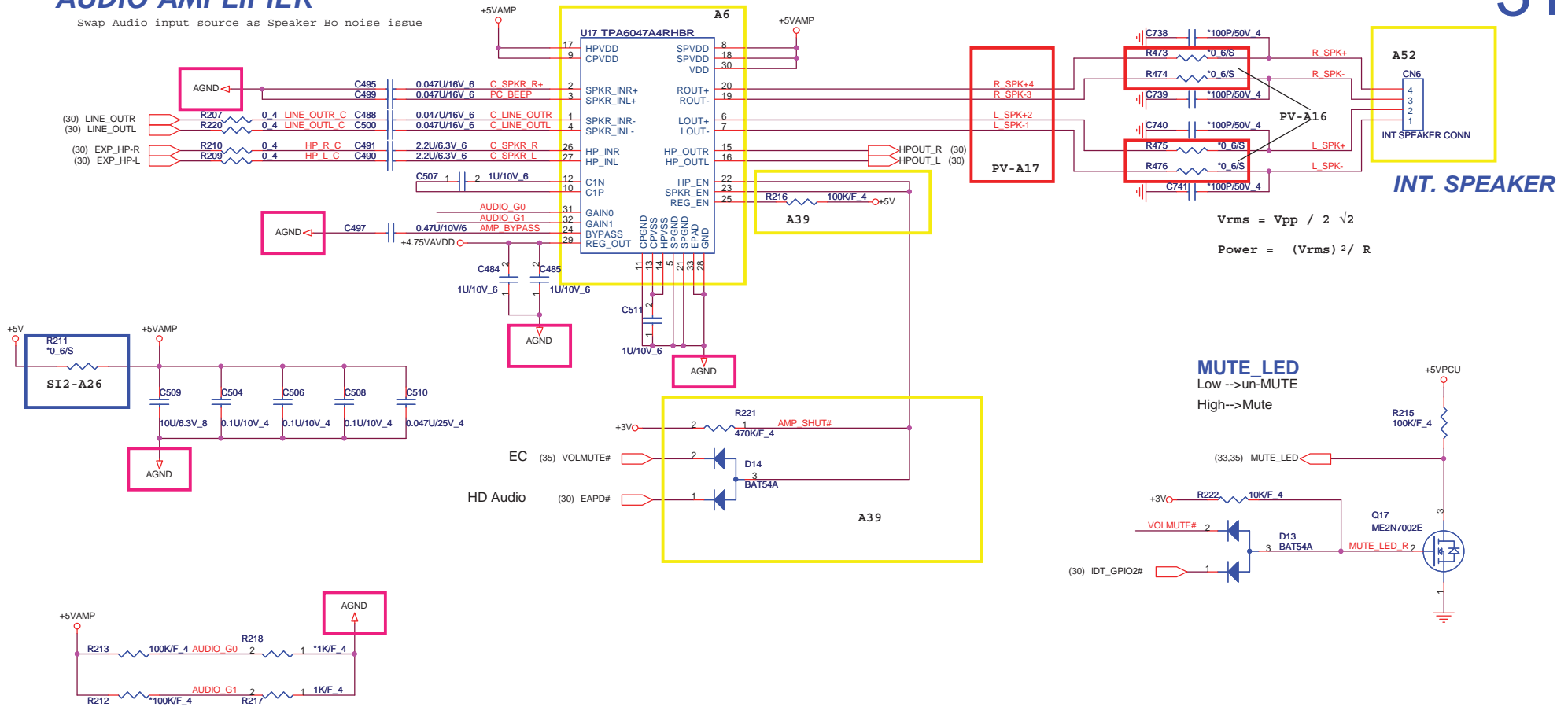

$$V_{rms} = V_{pp} / 2 \sqrt{2}$$

$$Power = (V_{rms})^2 / R$$

**MUTE\_LED**  
Low --> un-MUTE  
High --> Mute

6047A2 Gain Table

GAIN0	GAIN1	AV	RIN
0	0	6dB	90K
0	1	10dB	70K
1	0	15.6dB	45K
1	1	21.6dB	25K

PIN23 SPKR\_EN  
TPA6047A4 High enable

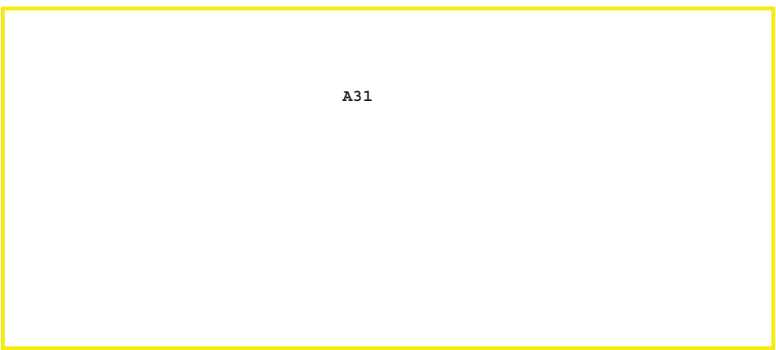
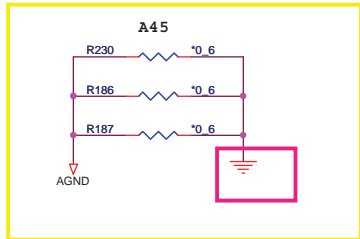

**PROJECT : SP6**  
**Quanta Computer Inc.**

Size Custom	Document Number	Rev 1A
<b>Audio Amplifier TPA6047A4</b>		
Date: Tuesday, April 07, 2009	Sheet 31	of 49

# BLUETOOTH

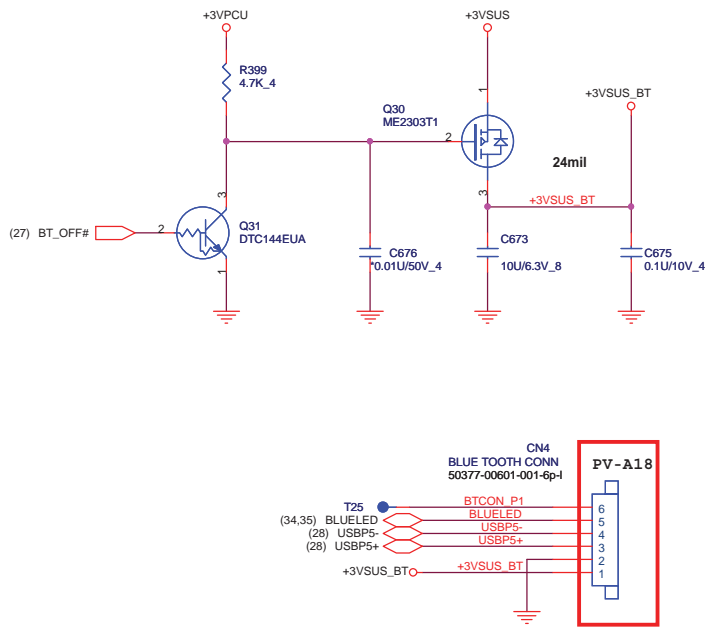

Change CN4 layout footprint to 50377-00601-001-6p-1

# LEFT SIDE USBX2

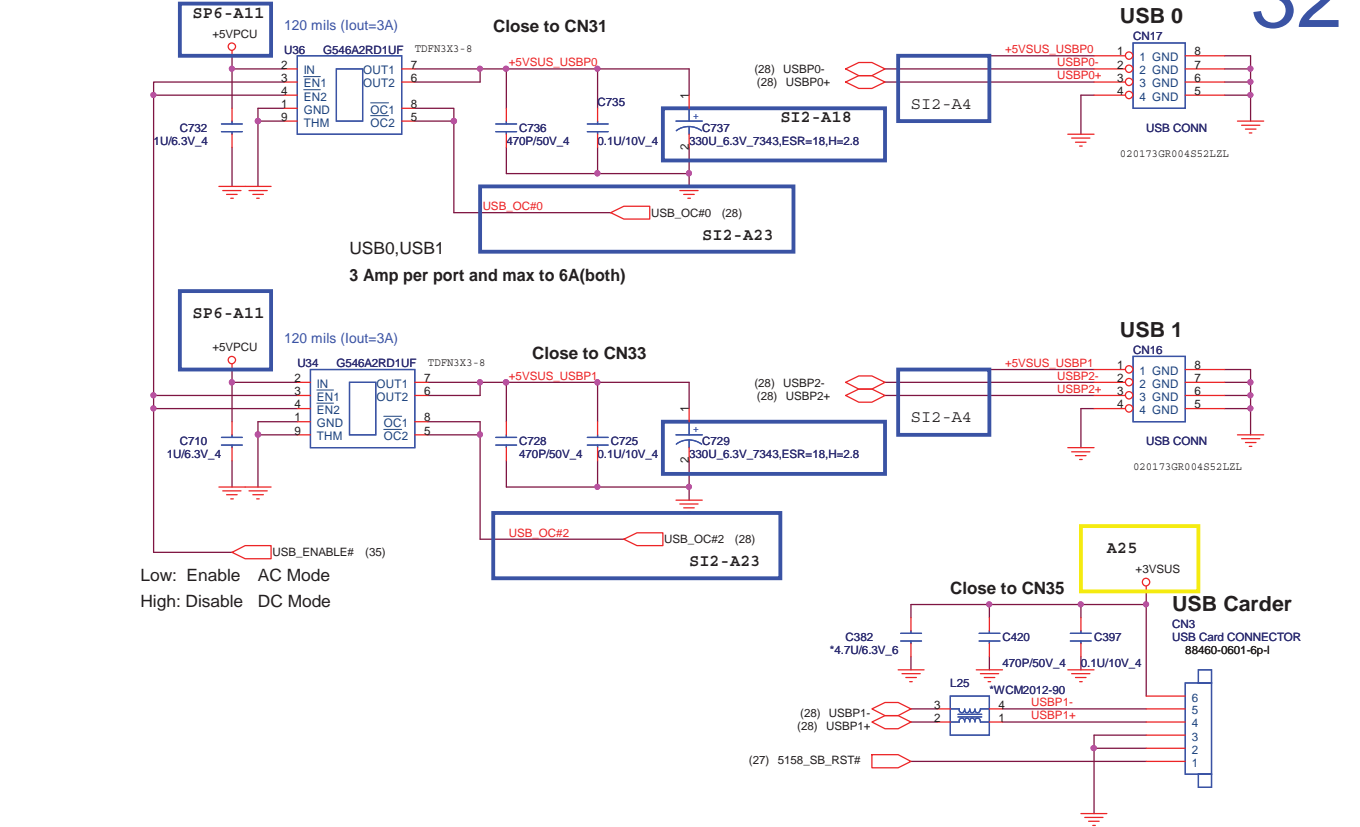

Low: Enable AC Mode  
High: Disable DC Mode

USB0,USB1  
3 Amp per port and max to 6A(both)

# Accelerometer Sensor

SGT-LIS302DLTR interrupt pin default is low / active Hi , BIOS need to programming 22h to change status from active Hi to low

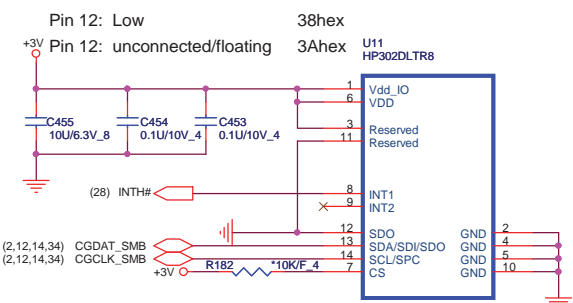

Change R181 to no stuff as internal pull high

# LED

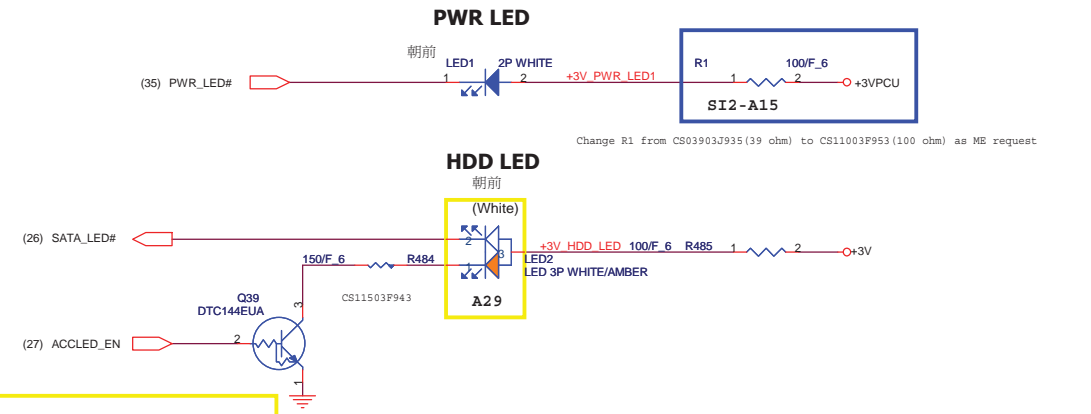

use a single 80 mil copper fill between digital ground and audio ground. None of the 0 ohm resistors should be used.

<http://laptop-motherboard-schematic.blogspot.com/>

	<b>PROJECT : SP6</b> Quanta Computer Inc.		Rev 1A
	Size Custom	Document Number <b>BT/WC/FP/USB/G-sensor</b>	
Sheet 32 of 49			



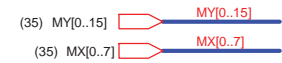
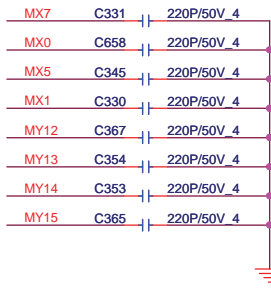
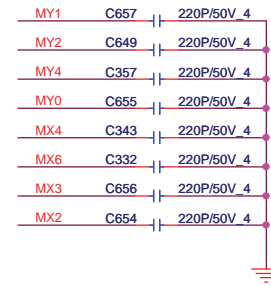
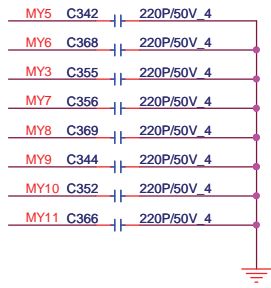
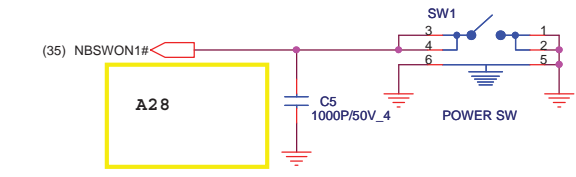
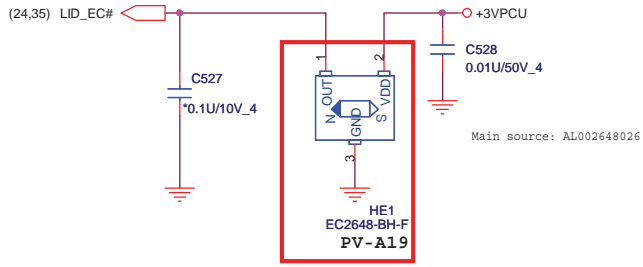

Modify CN2 footprint from b1137-32r1-tand-32p-1 to 196033-32041-32p-1

KEYBOARD PULL-UP

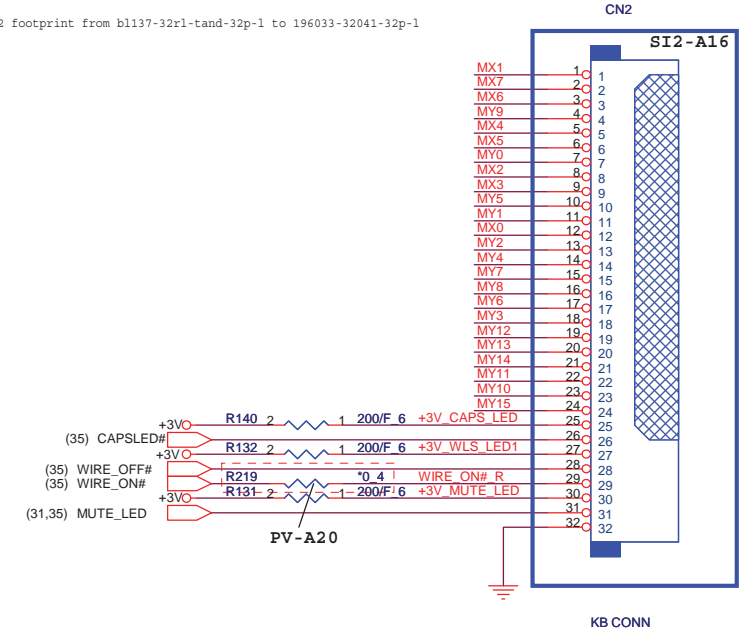
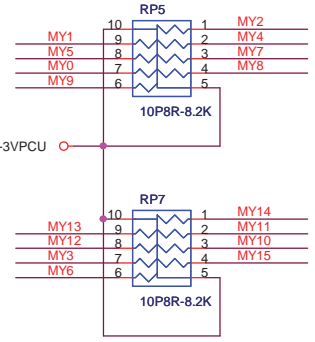

- Caps Lock LED 2 Pins 30mA
- Wireless LED 3 pins
- MUTE LED 2 Pins
- Charge LED 3 pins

Pin 32 Pin 1

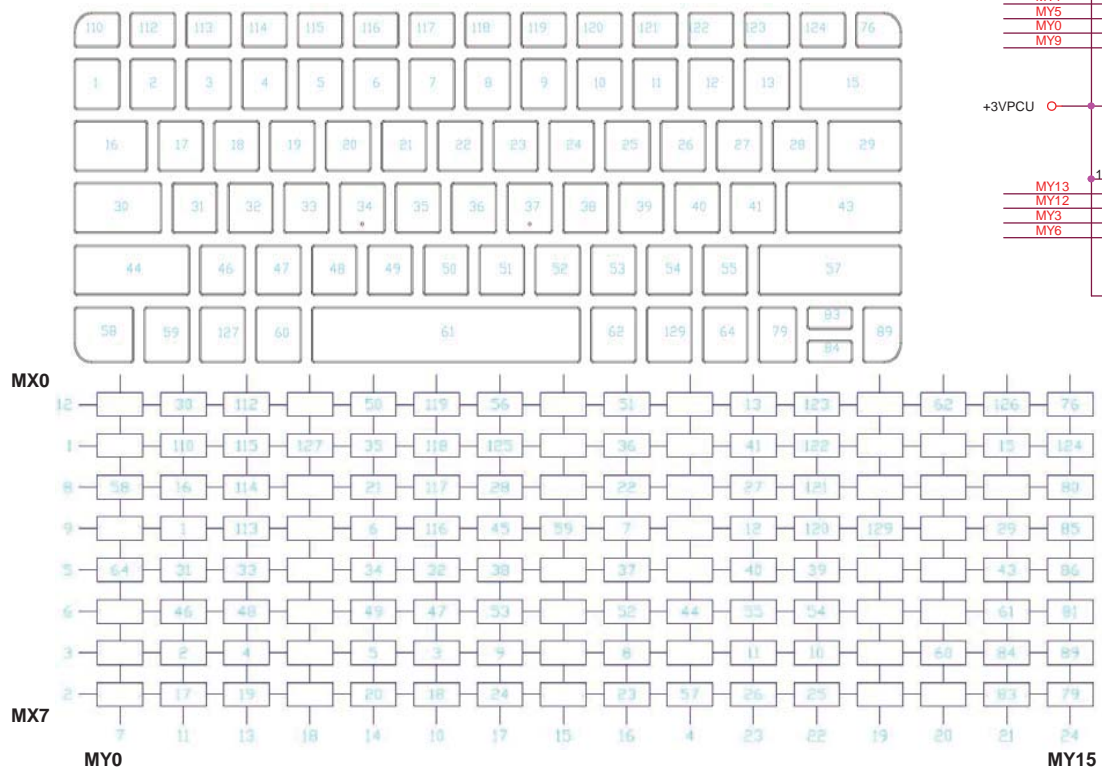

	<b>PROJECT : SP6</b> Quanta Computer Inc.		Rev 1A
	Size B	Document Number KB/CAP	

Full size Mini-Card  
WLAN

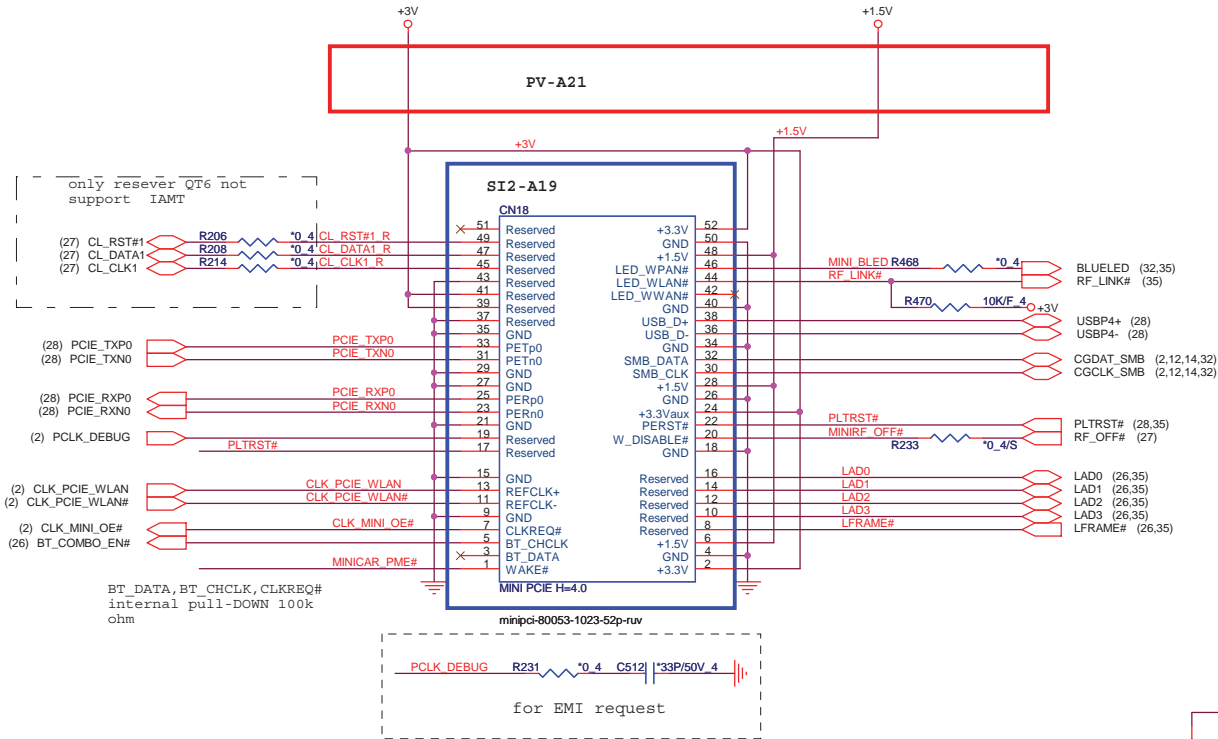

Modify CN18 footprint from from minipci-asob241-r40n-7h-52p-ruv to minipci-80053-1023-52p-ruv

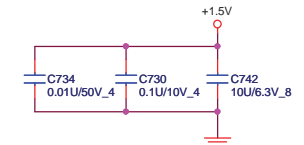

Close to CN38

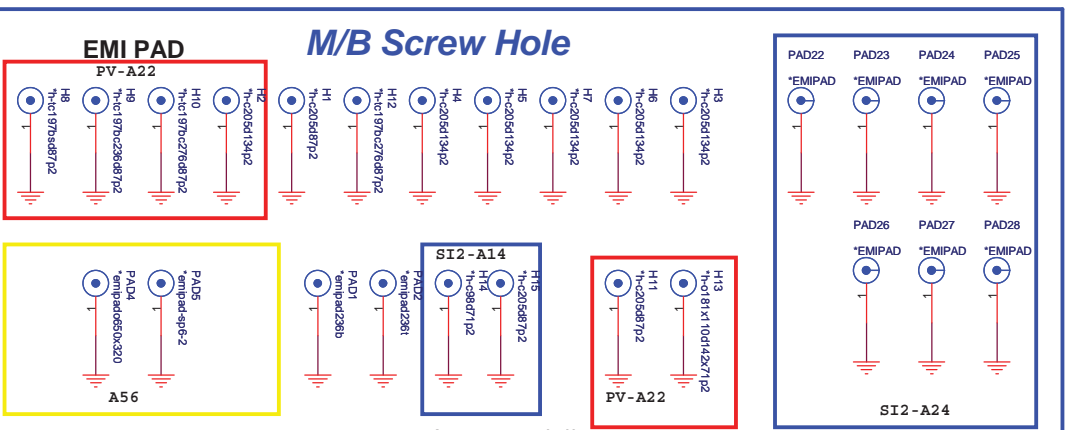
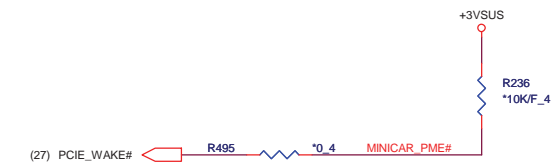
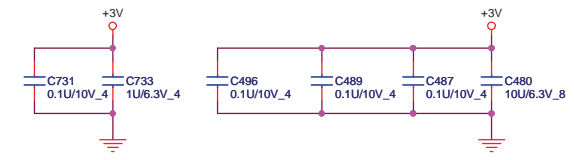

Delete PAD3, PAD6 and add H15

	<b>PROJECT : SP6</b> Quanta Computer Inc.		Rev 1A
	Size Custom	Document Number <b>MINIPCIE/Hole</b>	Date: Tuesday, April 07, 2009
Sheet 34 of 49			

Change U20 layout footprint to LQFP128-16X16-4-AA1

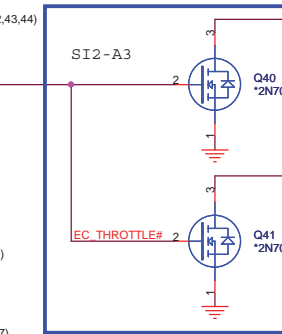
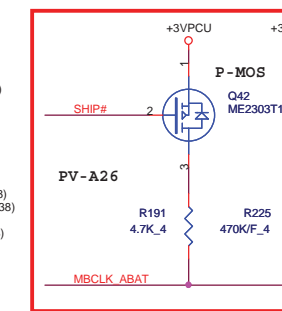
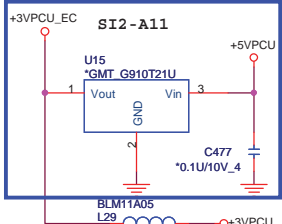
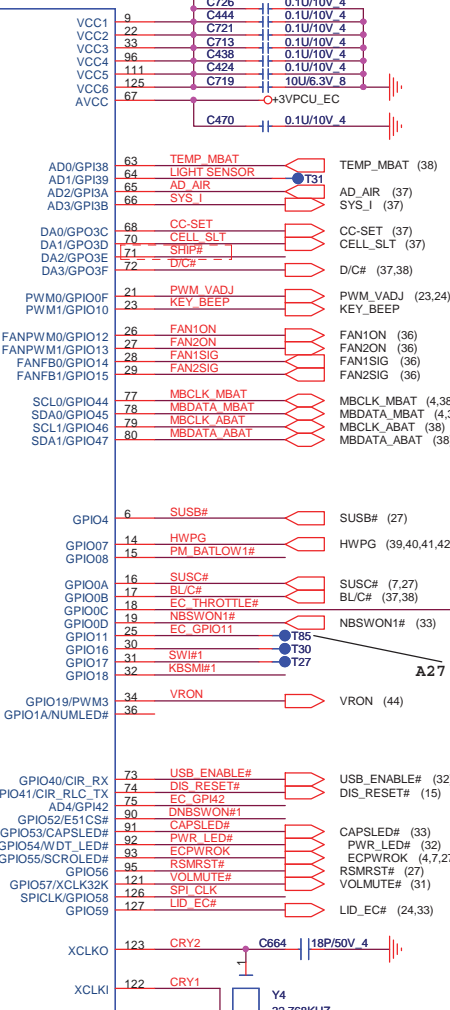
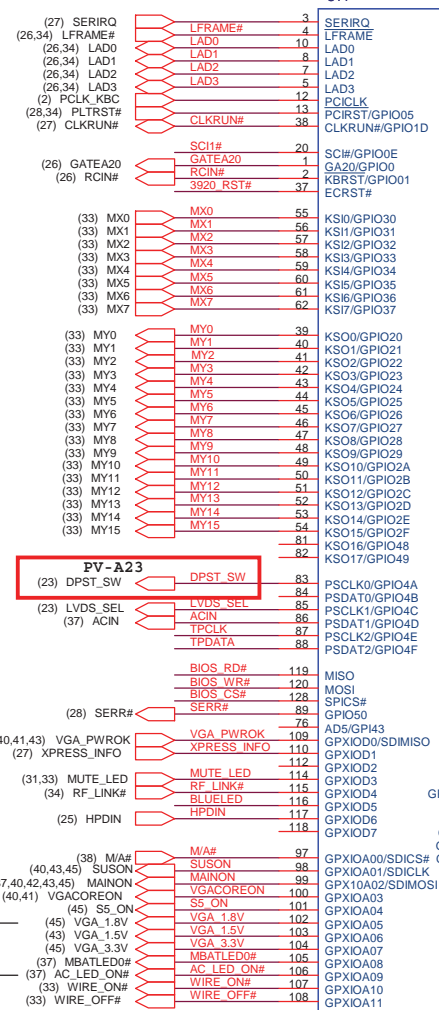

Socket: DG008000031

DB-2 From SI-1

8M bit 16M bit

MXIC AKE5GFK0Z09 AKE38FP0Z00

WINBOND AKE3GFP0N08 AKE38ZP0N01 AKE38FP0N01

EON AKE3GZP0Q00 AKE38ZA0Q00

AMIC AKE3GZP0801 AKE38ZN0800

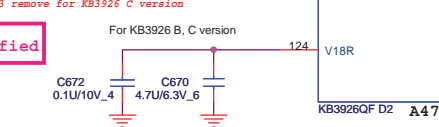
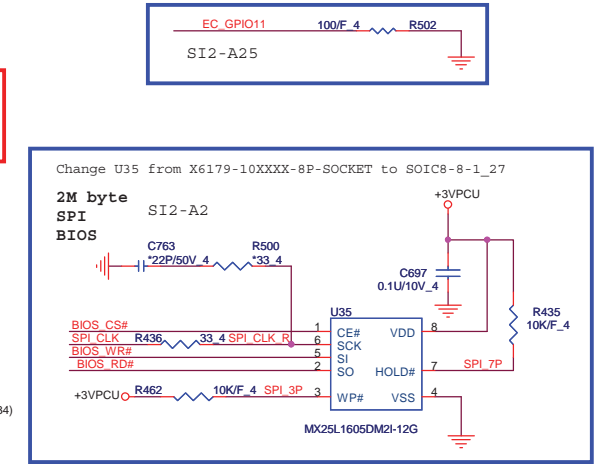
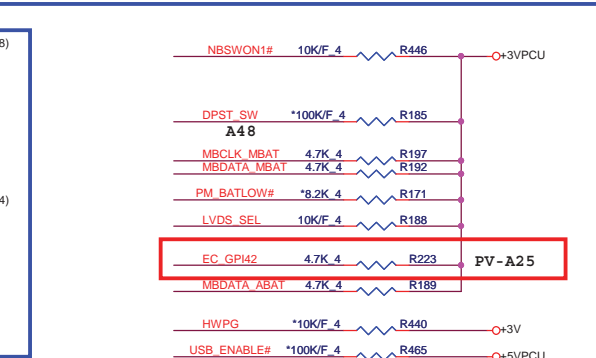
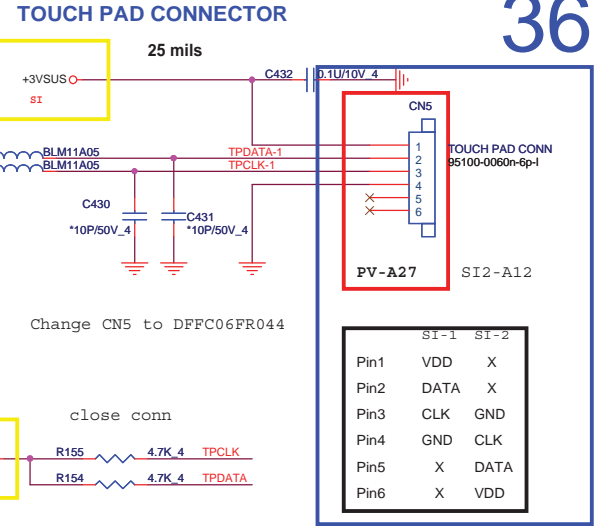

Add Pin 117,103 for DSM,116 for Bluetooth,Pin 23 for Key Beep to Amplifier

Add T37,T38,T39 for EC

Delete T10 and tie pin 117 from Lan for DSM

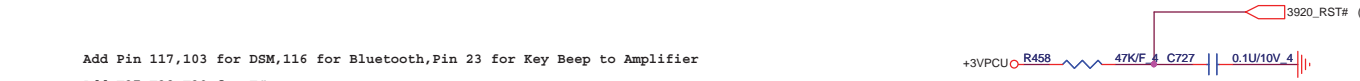

**PROJECT : SP6**  
Quanta Computer Inc.

Size Custom Document Number **KB3926/ROM/TP** Rev 2B

Date: Tuesday, April 07, 2009 Sheet 35 of 49

### SATA 1.8" HDD CONNECTOR

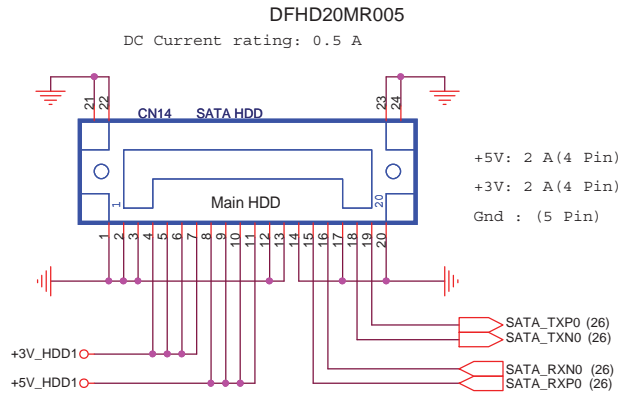

Modify 固定孔 Size as SMT request

GS12201-1011-9F-20P-L-QT6

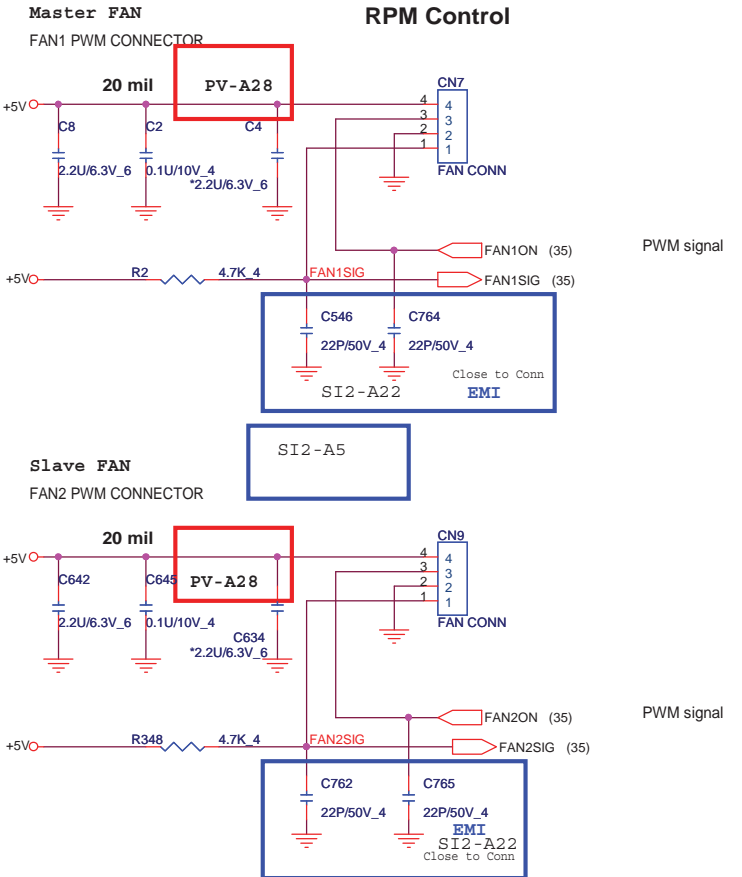
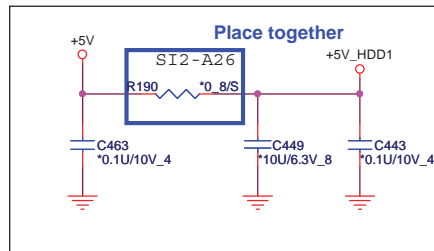
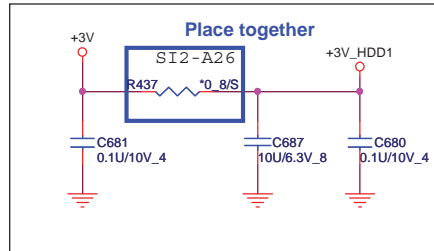

	<b>PROJECT : SP6</b> <b>Quanta Computer Inc.</b>	
	Size B Date: Tuesday, April 07, 2009	Document Number <b>Fan1 and Fan2</b> Sheet 36 of 49

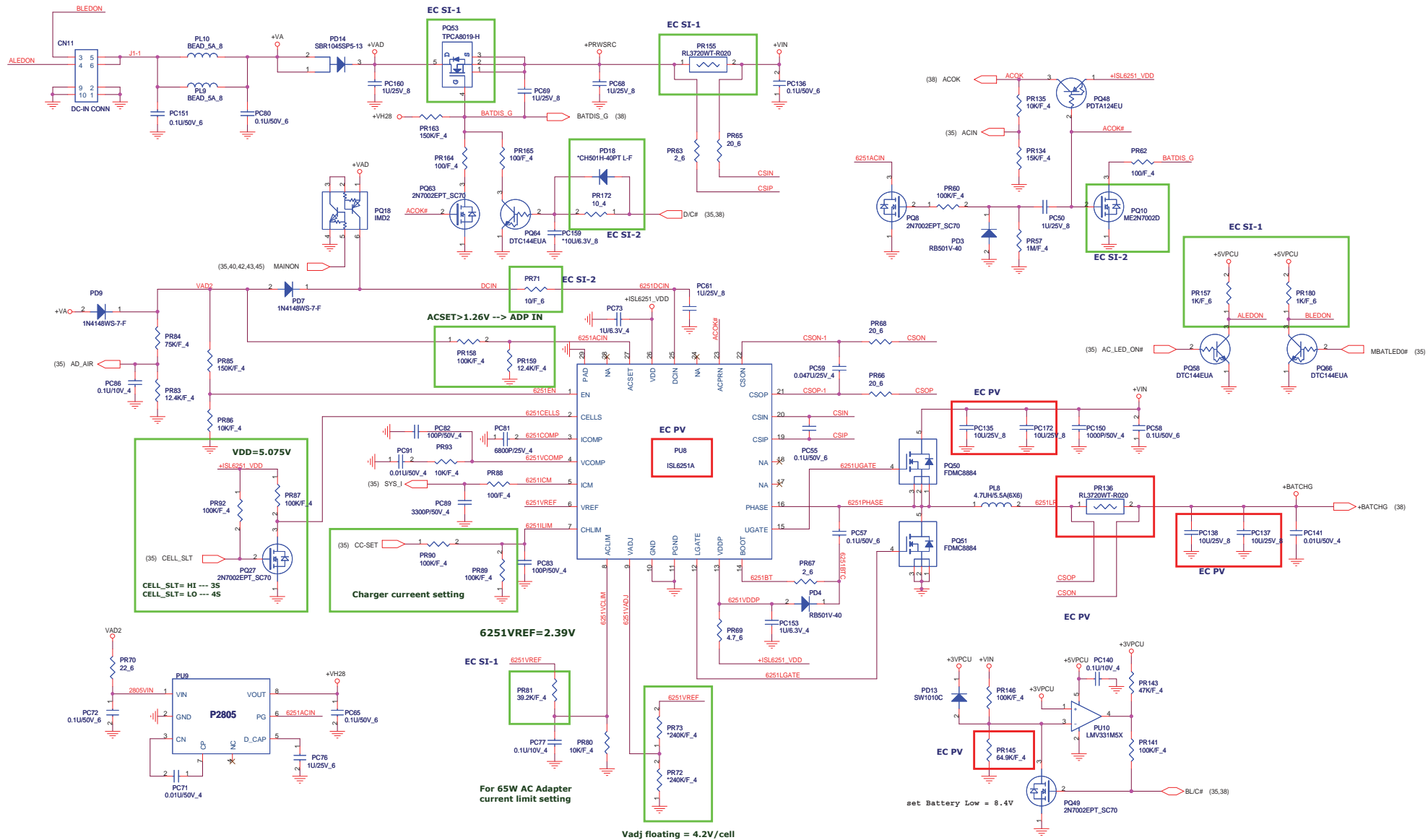

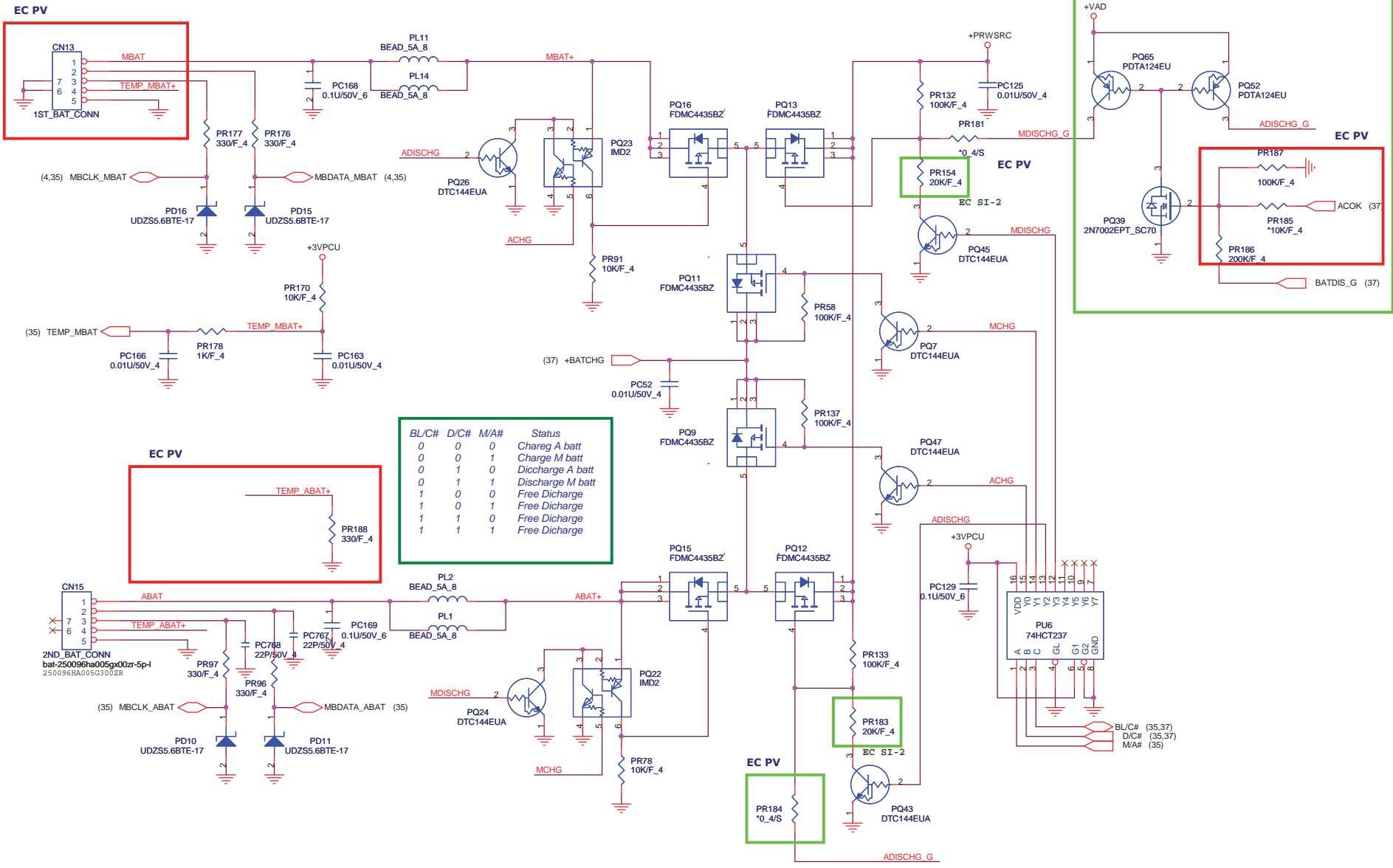

BL/C#	D/C#	M/A#	Status
0	0	0	Charge A batt
0	0	1	Charge M batt
0	1	0	Discharge A batt
0	1	1	Discharge M batt
1	0	0	Free Discharge
1	0	1	Free Discharge
1	1	0	Free Discharge
1	1	1	Free Discharge

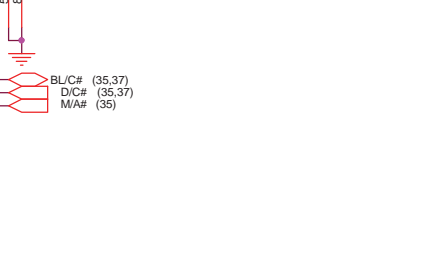
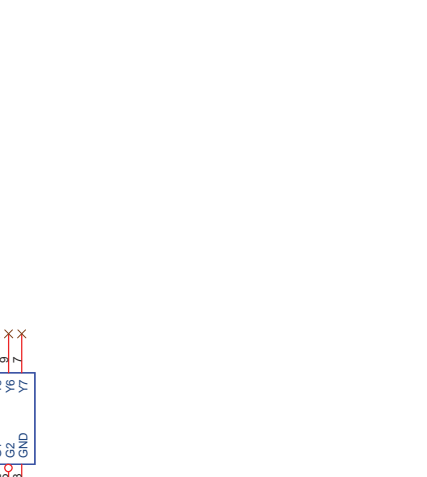
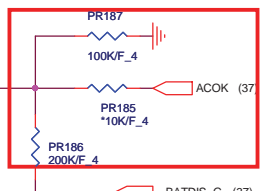
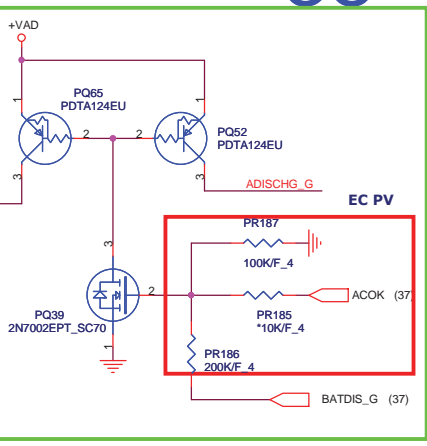

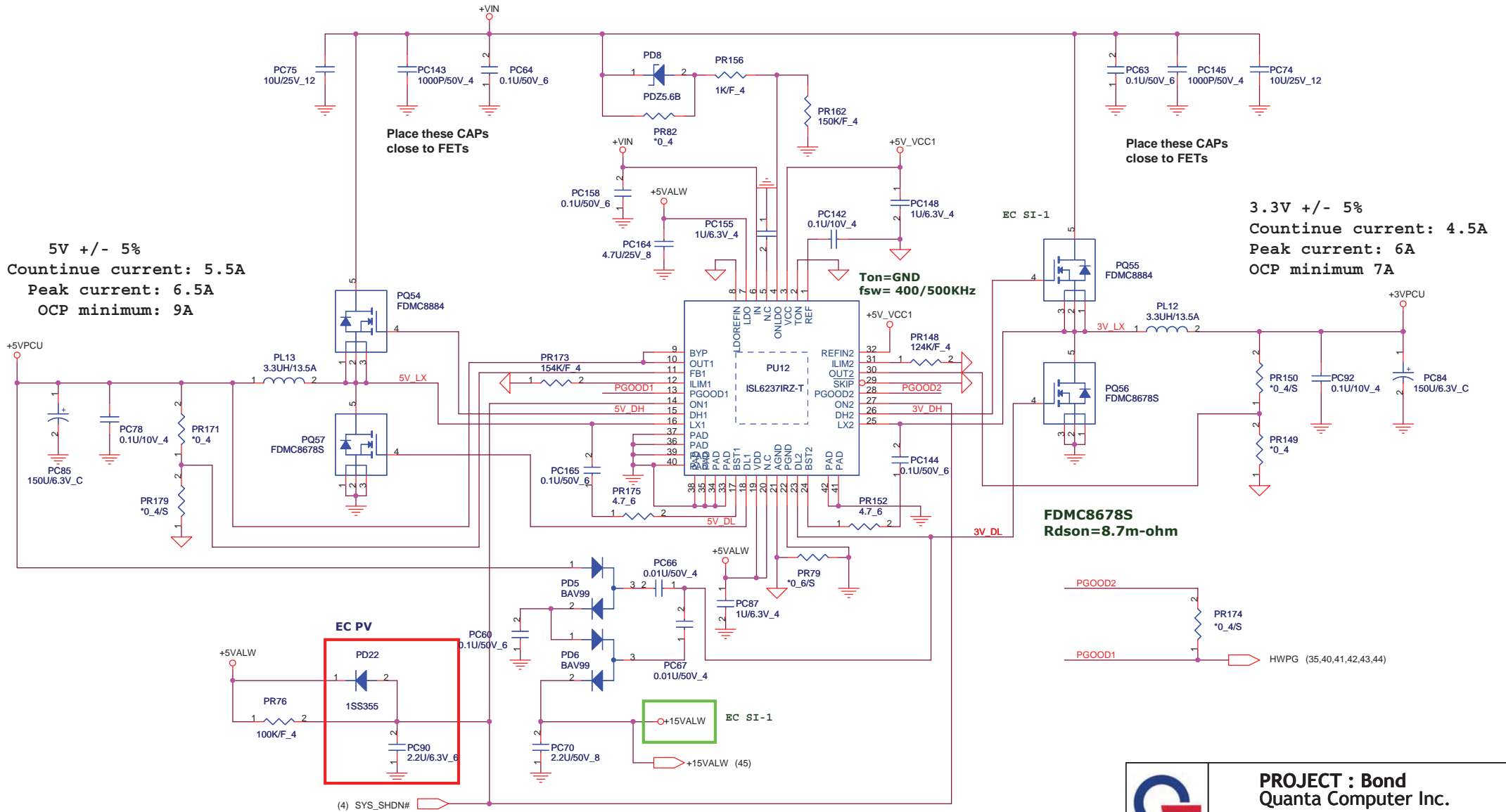

5V +/- 5%  
 Countinue current: 5.5A  
 Peak current: 6.5A  
 OCP minimum: 9A

Place these CAPS  
 close to FETs

Place these CAPs  
 close to FETs

3.3V +/- 5%  
 Countinue current: 4.5A  
 Peak current: 6A  
 OCP minimum 7A

FDMC8678S  
 Rdson=8.7m-ohm

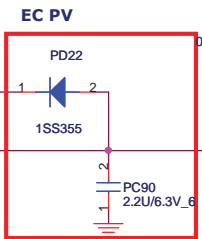

(4) SYS\_SHDN#



PROJECT : Bond  
 Quanta Computer Inc.

Size B	Document Number <b>+5V/+3V</b>	Rev 1A
Date: Tuesday, April 07, 2009	Sheet 39 of 49	

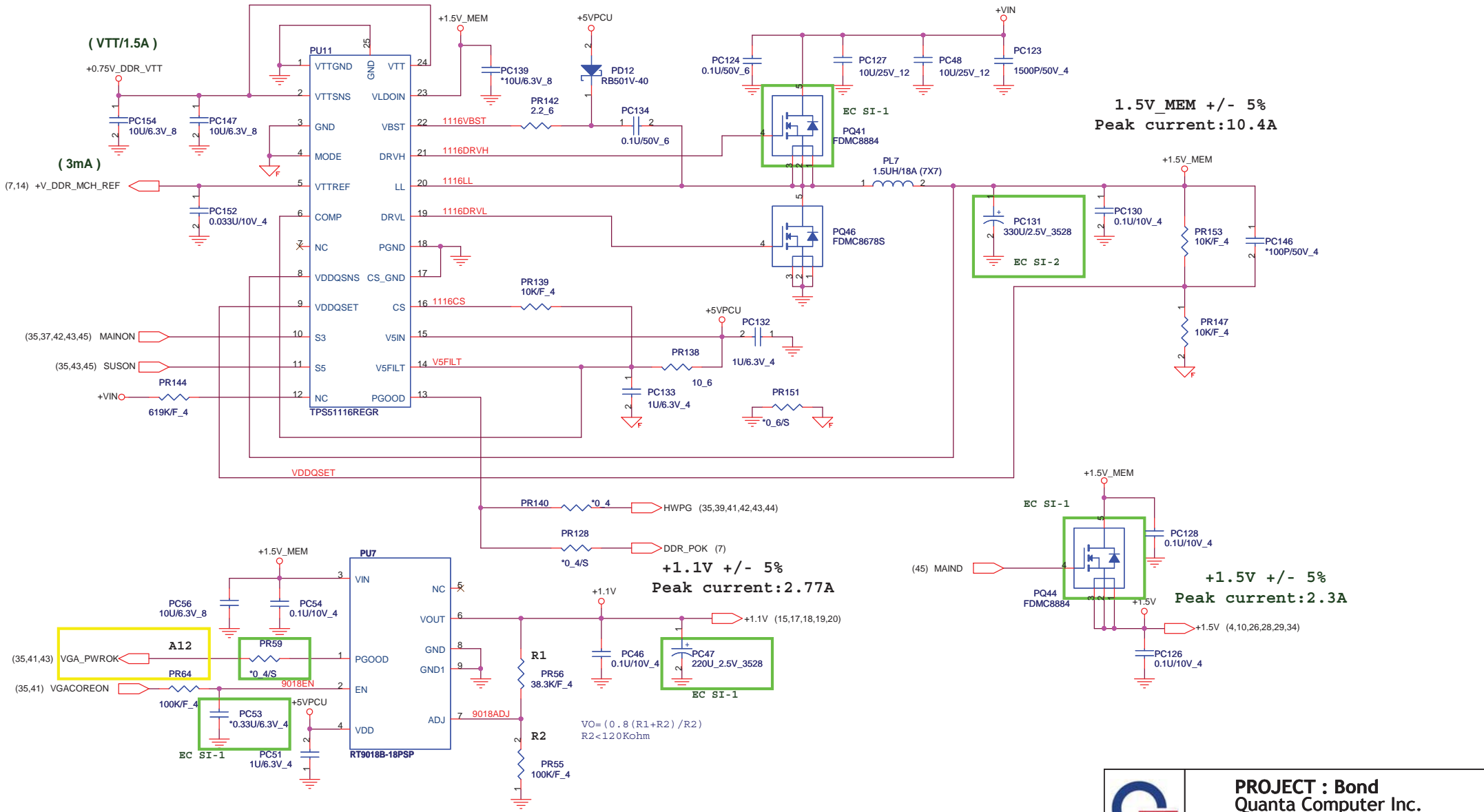

1.5V\_MEM +/- 5%  
Peak current:10.4A

+1.1V +/- 5%  
Peak current:2.77A

+1.5V +/- 5%  
Peak current:2.3A



**PROJECT : Bond**  
**Quanta Computer Inc.**

Size B	Document Number <b>+1.5V_MEM+1.1V</b>	Rev 1A
Date: Tuesday, April 07, 2009 Sheet 40 of 49		



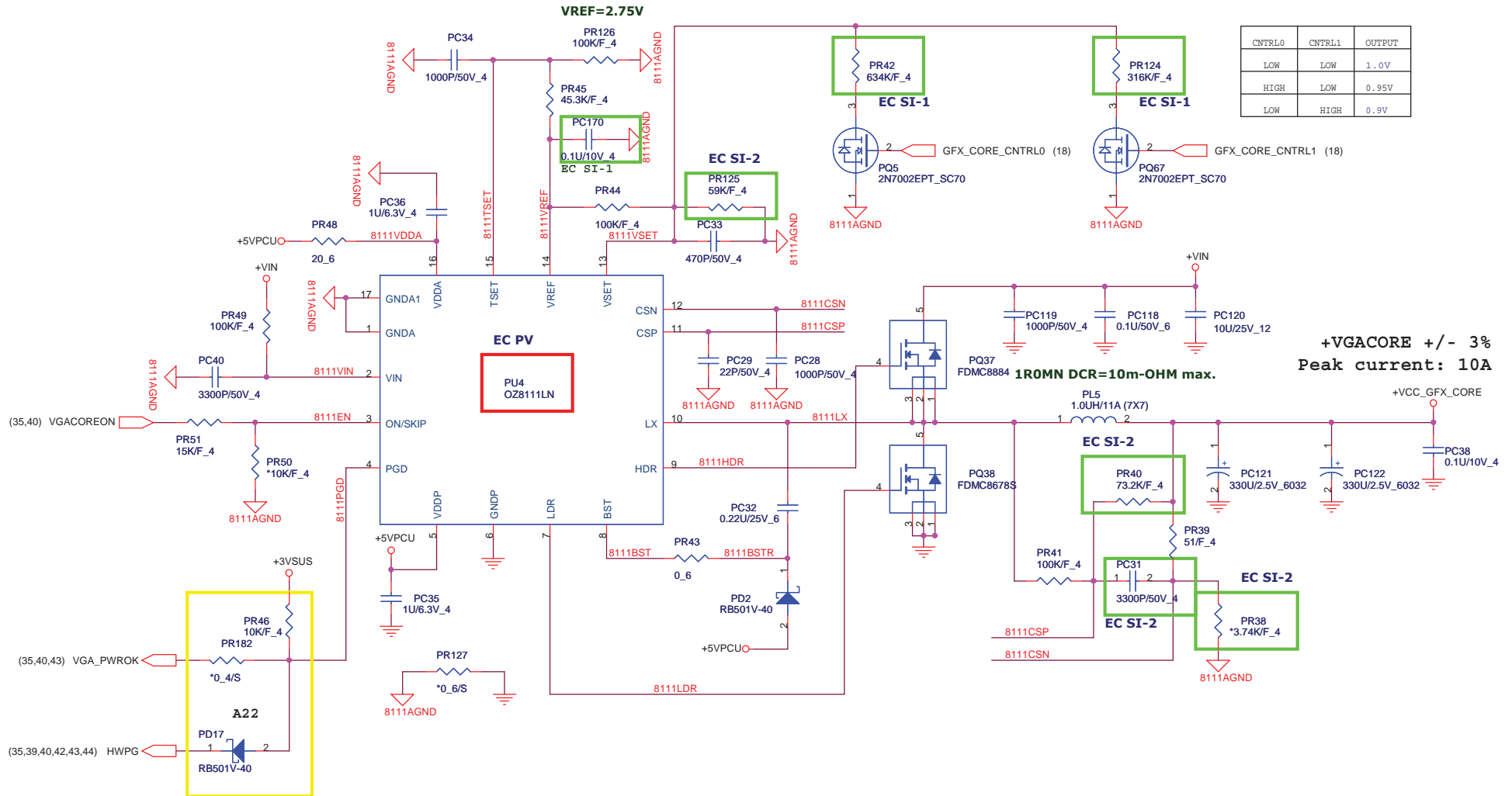

CNTRL0	CNTRL1	OUTPUT
LOW	LOW	1.0V
HIGH	LOW	0.95V
LOW	HIGH	0.9V

**+VGACORE +/- 3%**  
**Peak current: 1.0A**



**PROJECT : Bond**  
**Quanta Computer Inc.**

Size B	Document Number <b>VGACORE</b>	Rev 1A
Date: Tuesday, April 07, 2009		Sheet 41 of 49

# VCCP1.05V

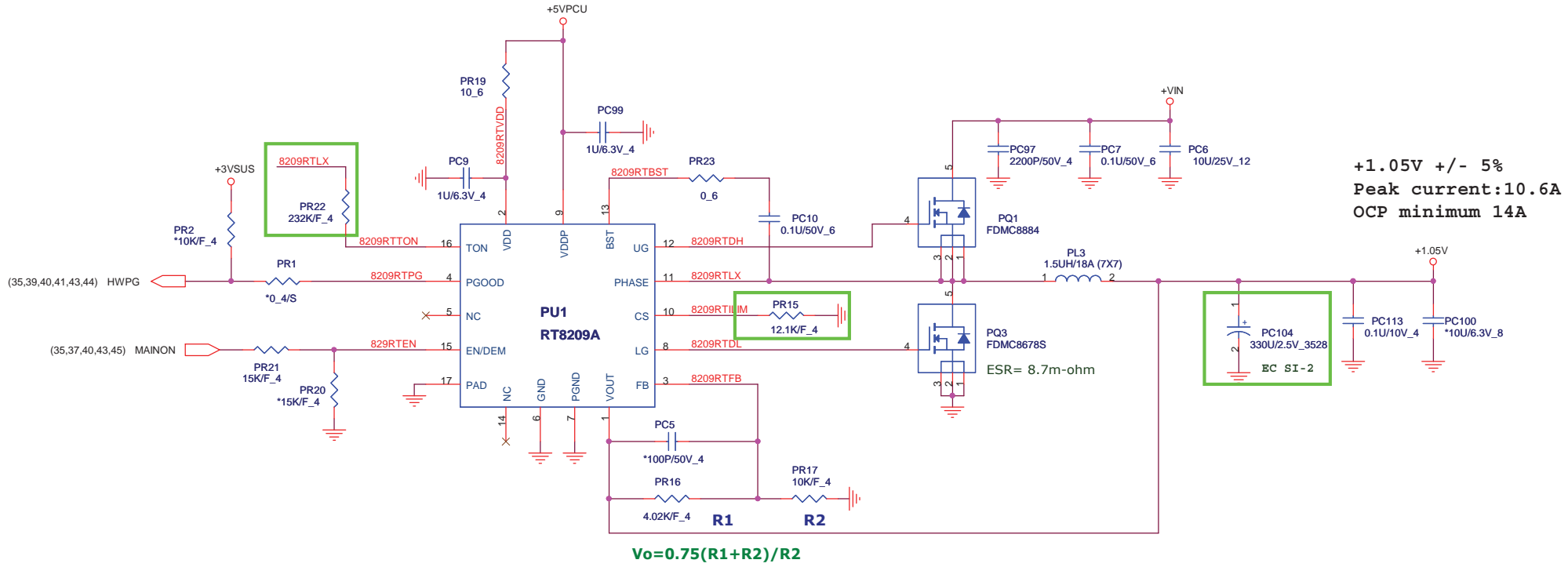

	<b>PROJECT : Bond Quanta Computer Inc.</b>	
	Size B	Document Number <b>+1.05V/+1.5V</b>
Date: Tuesday, April 07, 2009		Sheet 42 of 49

# +1.8V/+1.5V\_VGA

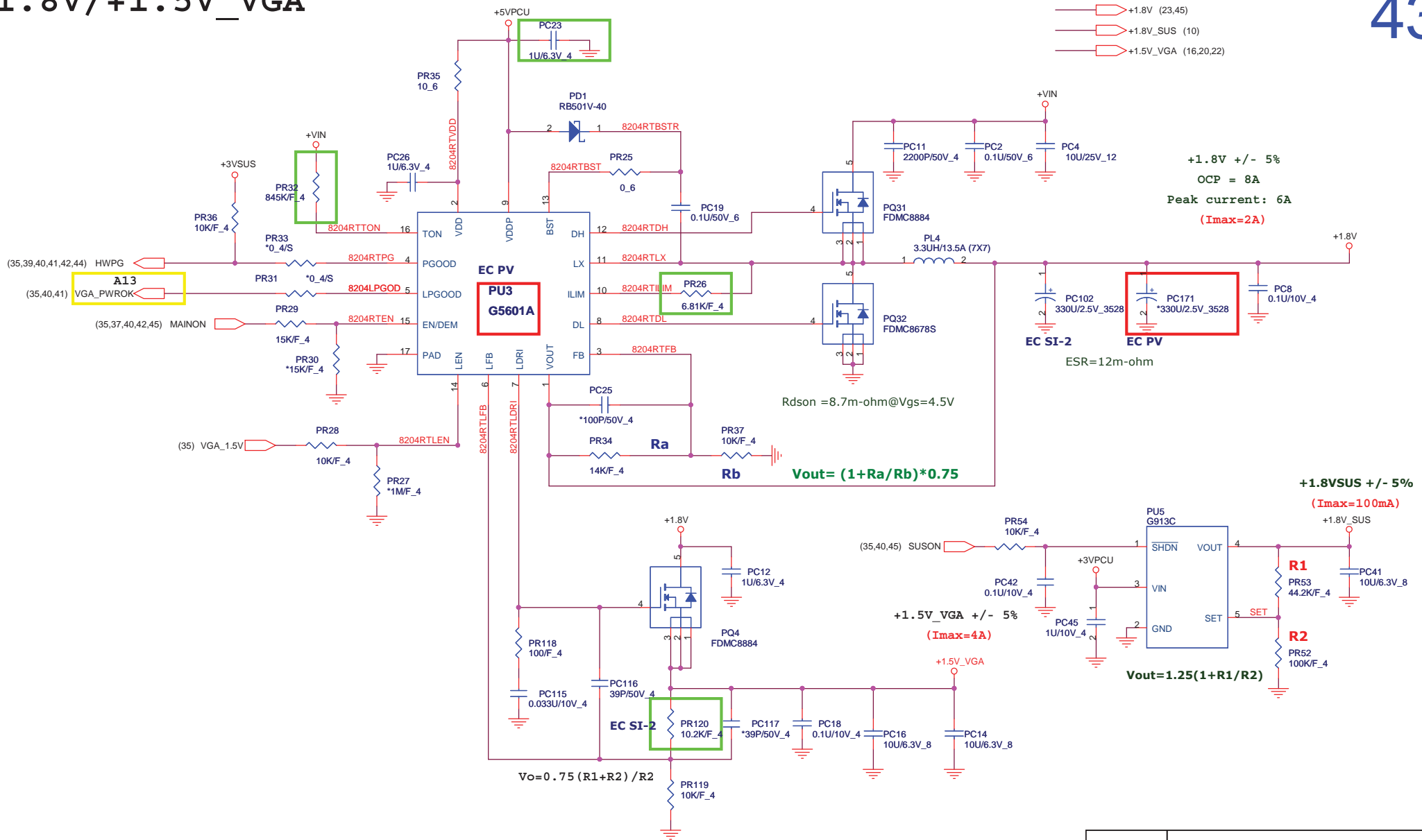

**PROJECT : Bond Quanta Computer Inc.**

Size B	Document Number <b>+1.05V/+1.5V</b>	Rev 1A
Date: Tuesday, April 07, 2009	Sheet 43 of 49	

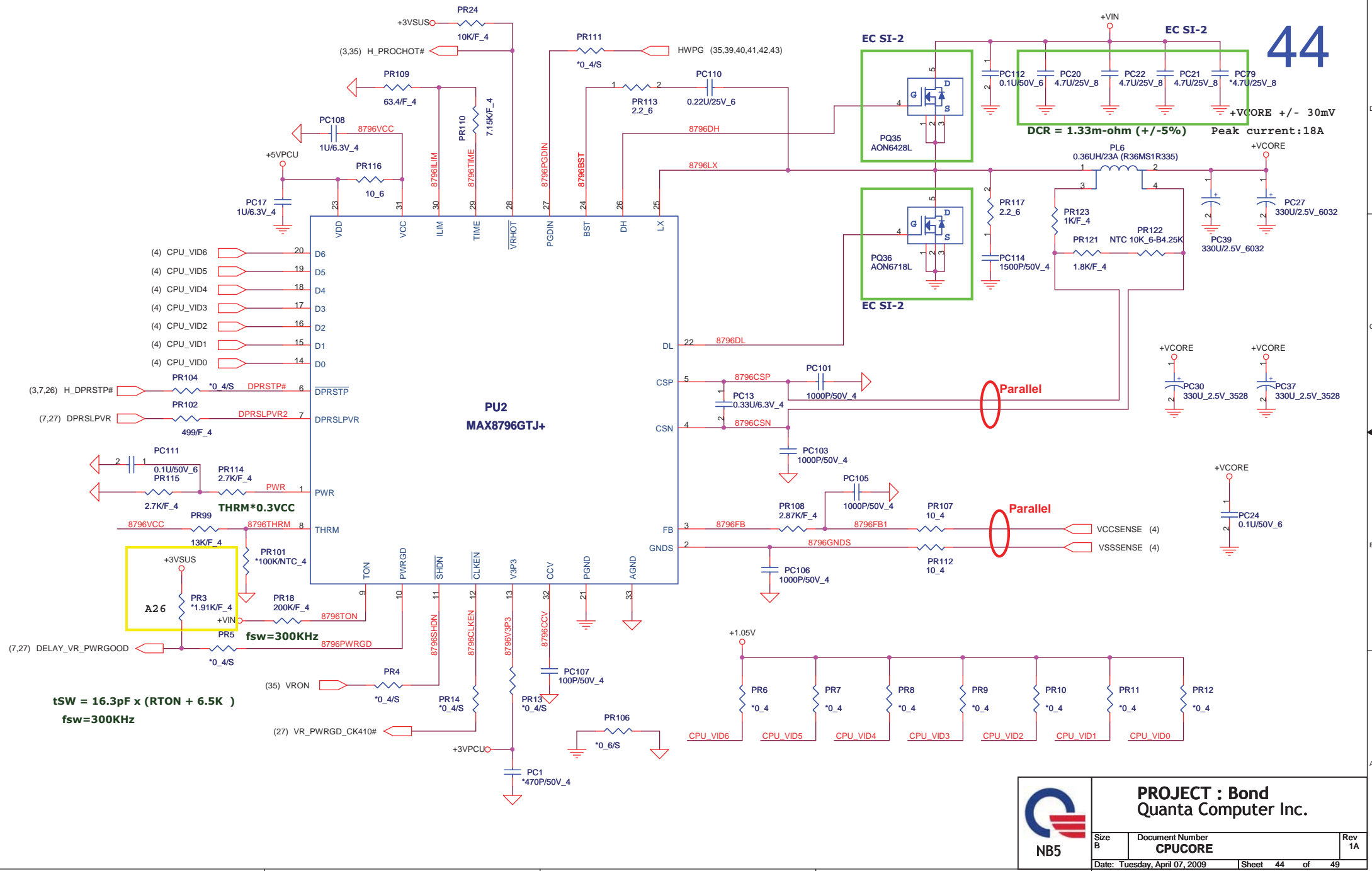

- (4) CPU\_VID6
- (4) CPU\_VID5
- (4) CPU\_VID4
- (4) CPU\_VID3
- (4) CPU\_VID2
- (4) CPU\_VID1
- (4) CPU\_VID0

**PU2**  
**MAX8796GTJ+**

$t_{SW} = 16.3pF \times (R_{TON} + 6.5K)$   
 $f_{sw} = 300KHz$



**PROJECT : Bond**  
**Quanta Computer Inc.**

Size B	Document Number <b>CPUCORE</b>	Rev 1A
Date: Tuesday, April 07, 2009	Sheet 44 of 49	

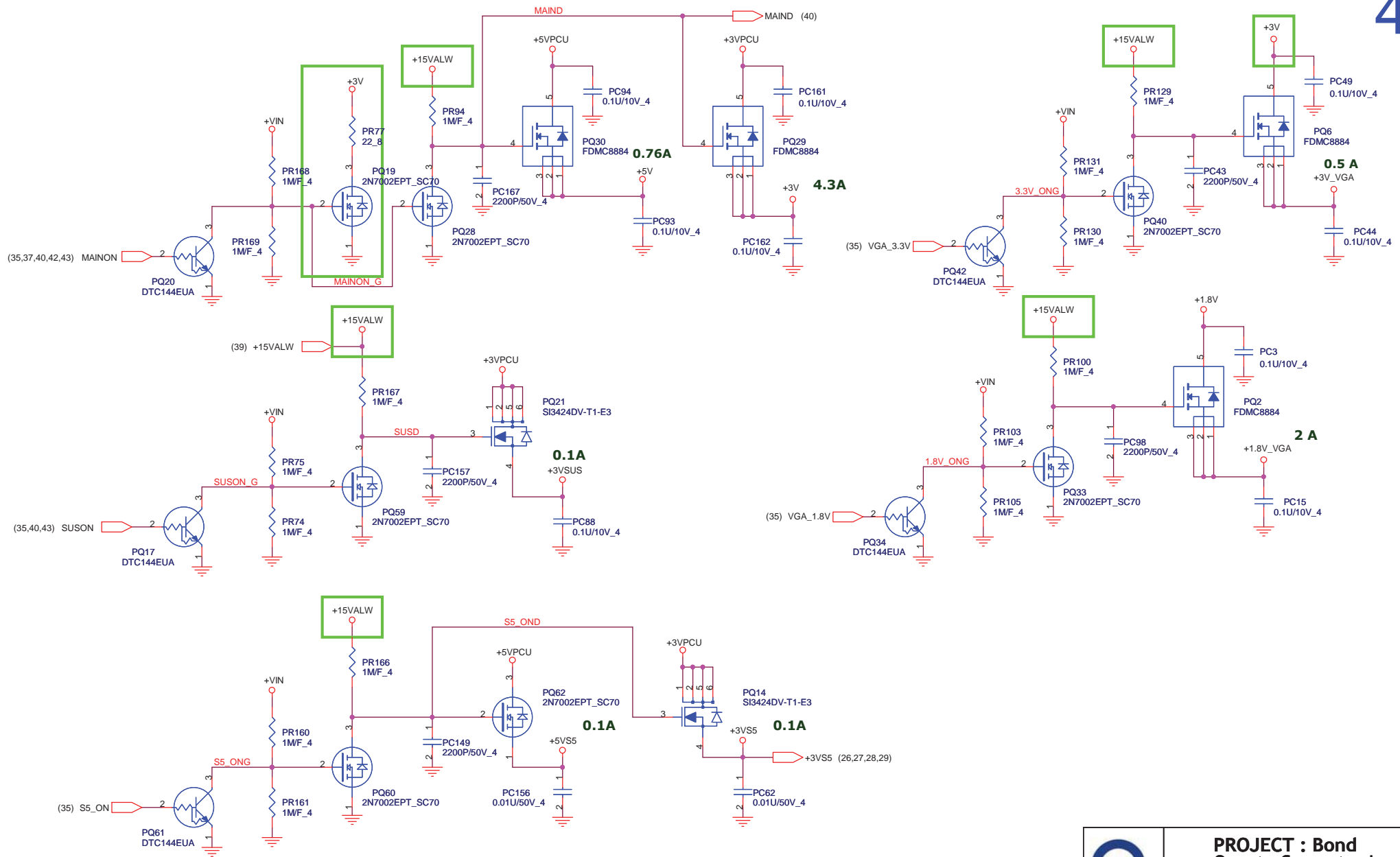

PROJECT : Bond  
Quanta Computer Inc.

Size B	Document Number <b>DISCHARGER</b>	Rev 1A
Date: Tuesday, April 07, 2009		Sheet 45 of 49