

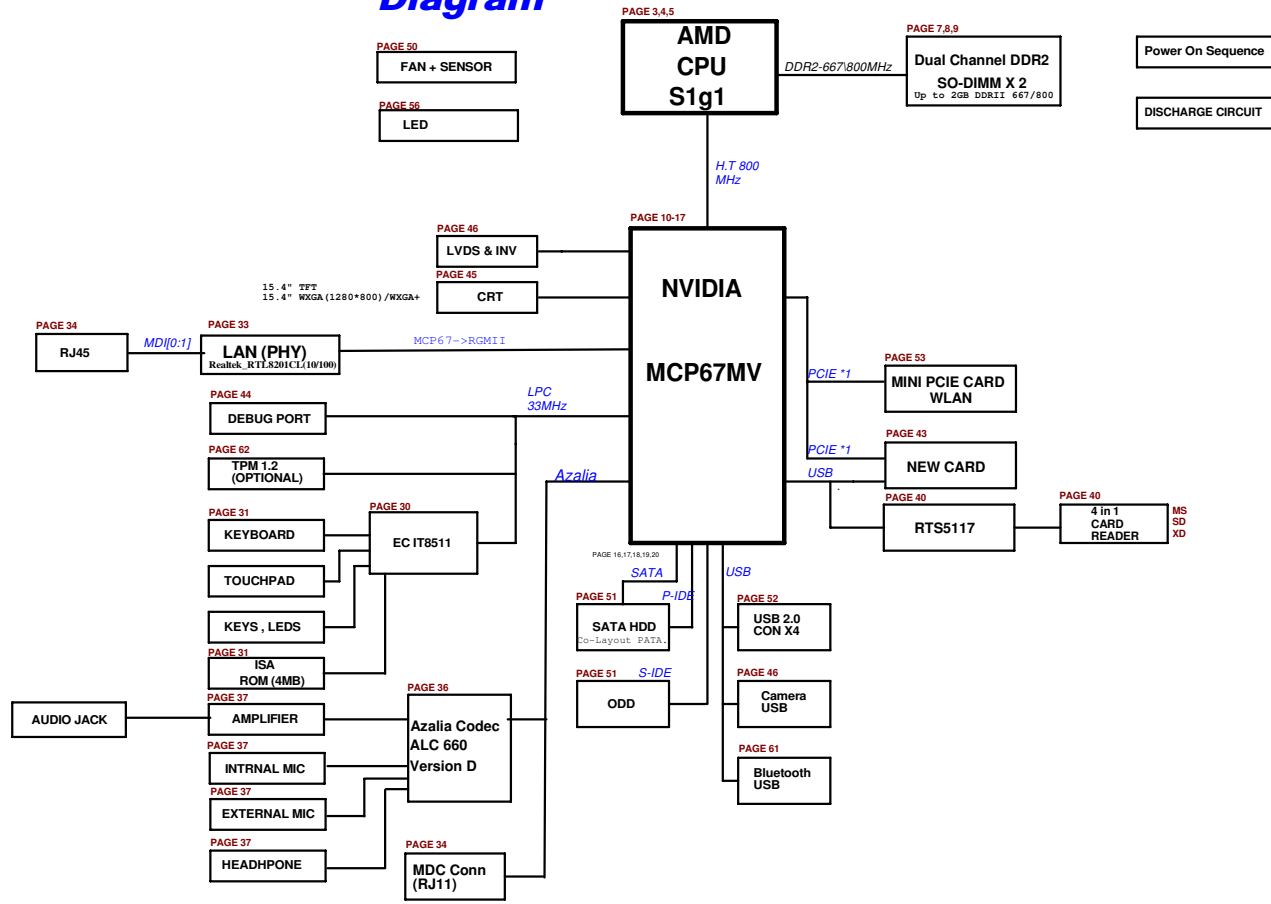

F5N Block Diagram



| | | | |
|---|--------------|-------------------|----------------|
|  | | Title : FSU | |
| ASUSTeK Computer INC. | | Engineer: He_Wang | |
| Size | Project Name | | Rev |
| C | FSU | | 1.0 |
| Date: 2017-11-28 20:07 | | | Sheet: 3 of 28 |

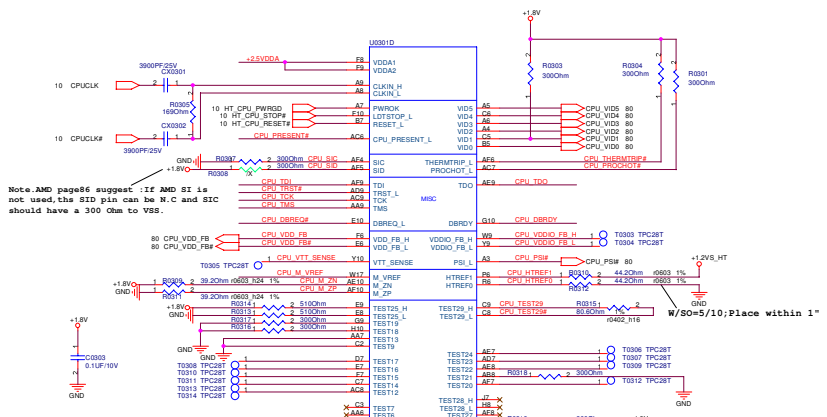

Note: AMD page(s) suggest if AMD 21 is not used, the SID pin can be N.C. and SIC should have a 300 Ohm to VSS.

12G011306380

Best and design guide (DC Resistance $\leq 40\text{ m}\Omega$, Inductance $\leq 100\text{ nH}$, Impedance $\leq 1\text{ }\Omega$, approximately 35ohm)

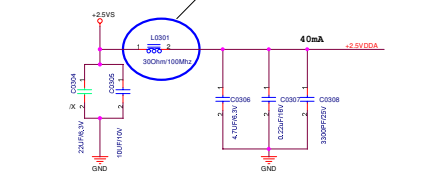

15milis trace, 20mil space /Shorter than 6"

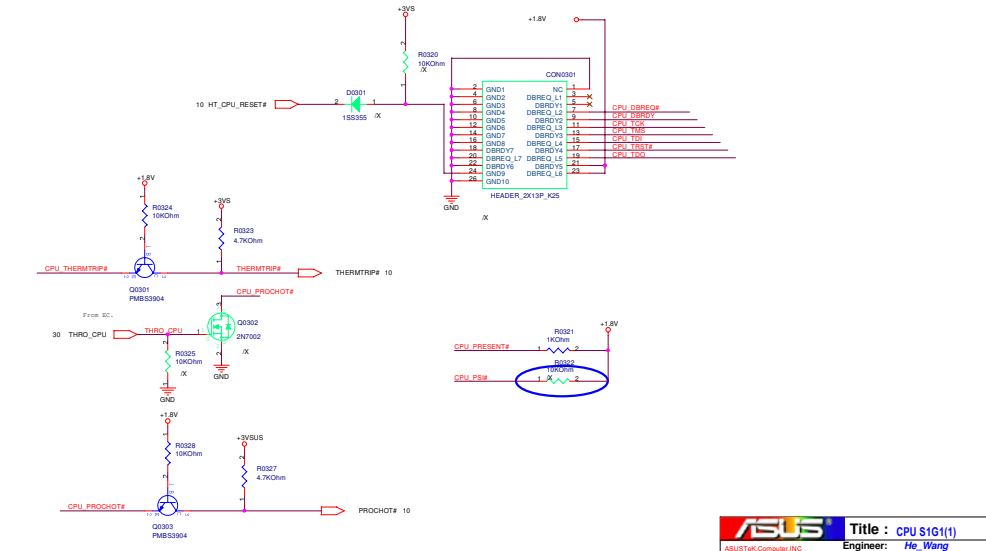
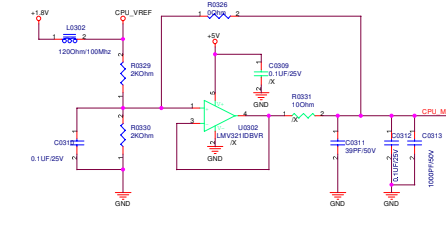

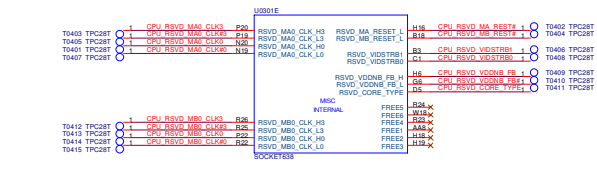
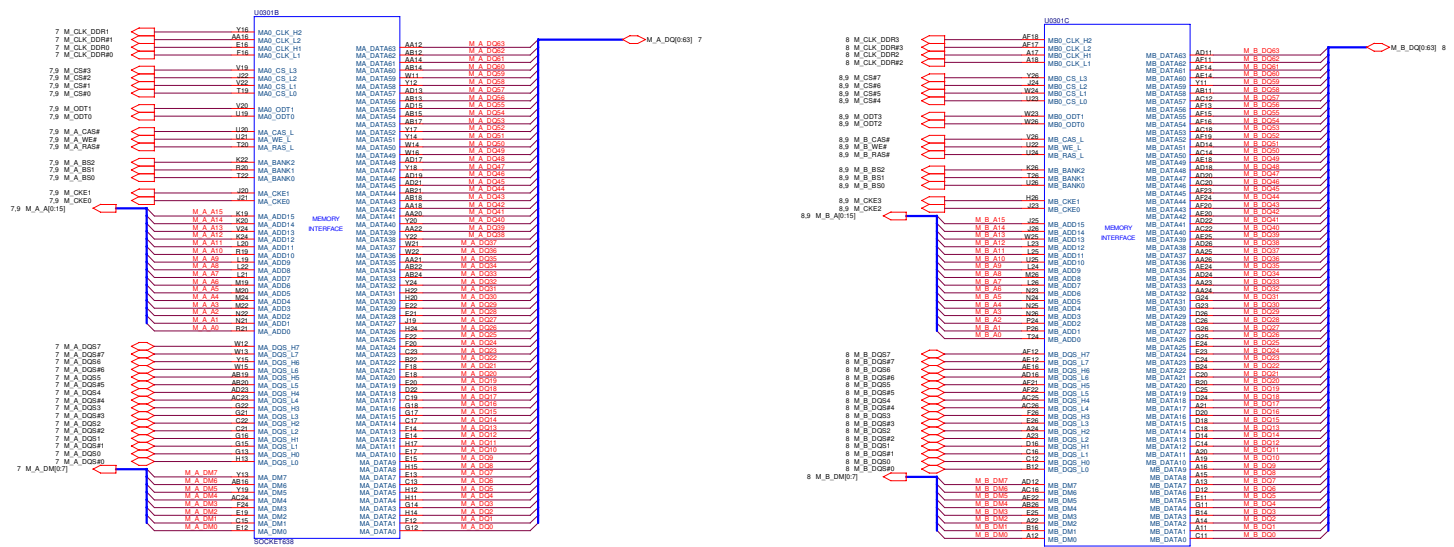

PLEASE CLOSE TO PROCESSOR WITHIN 1.2 INCH

PLEASE CLOSE TO PROCESSOR WITHIN 1.2 INCH

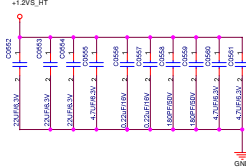
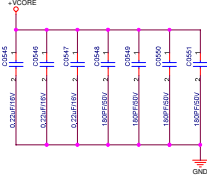
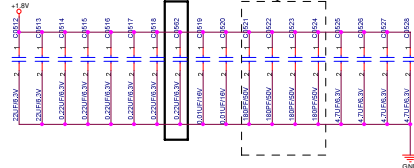
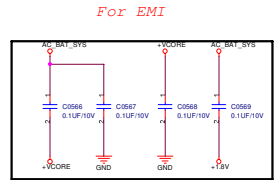
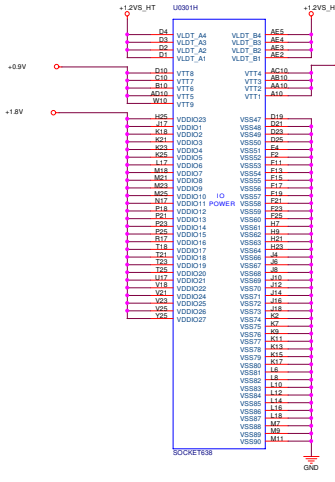
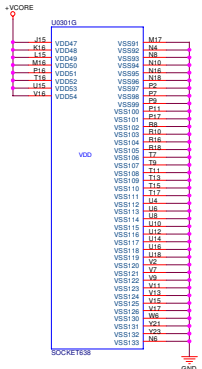
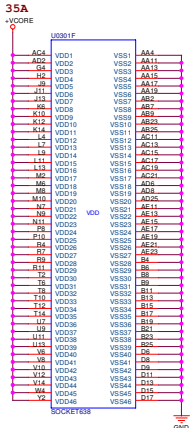

| | | | |
|---|--------------|-------------------|--|
|  | | Title : FSU | |
| ASUSTek Computer Inc. | | Engineer: He Wang | |
| Size | Project Name | Rev | |
| C | FSU | 1.0 | |
| Date: 2011-03-29 10:07 | | Sheet 6 of 26 | |

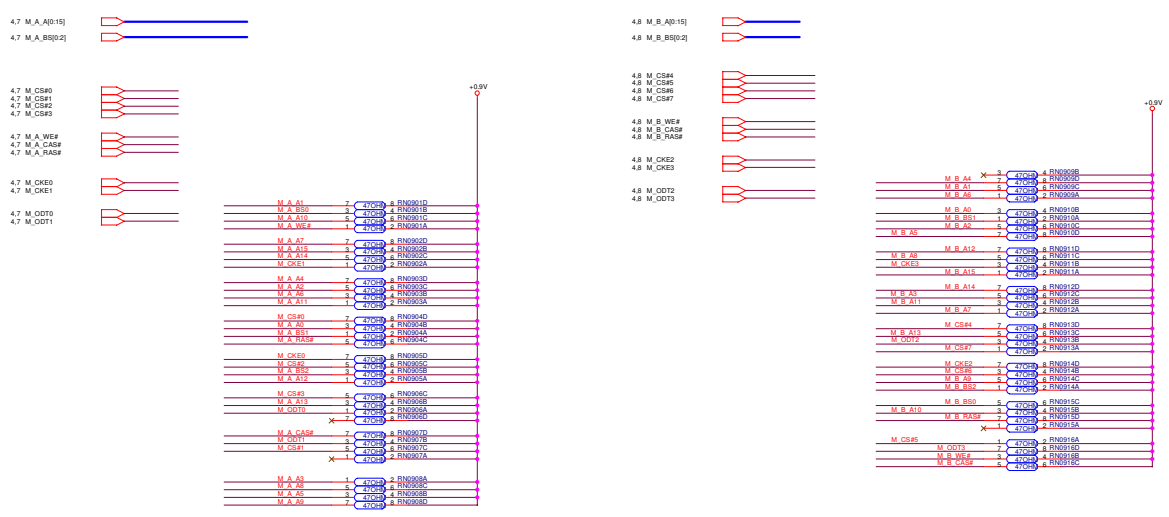

Layout Note: Place one cap close to every 2 pullup resistors terminated to +0.9V

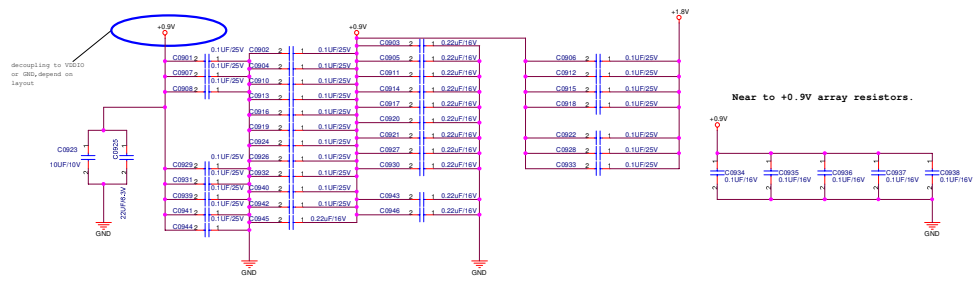

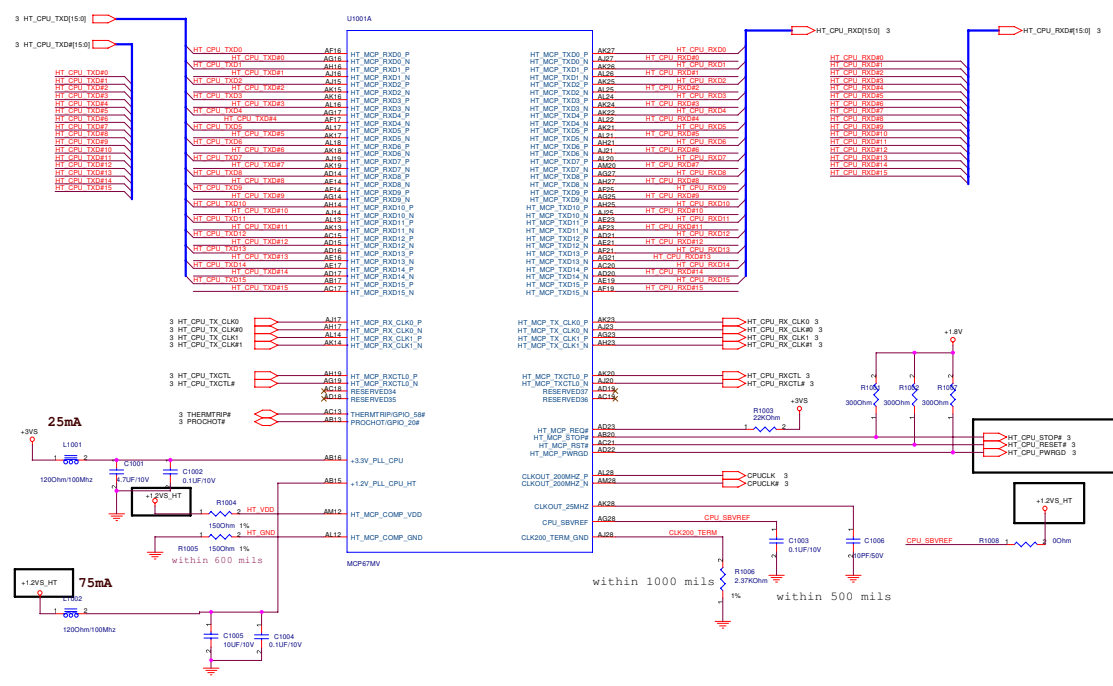

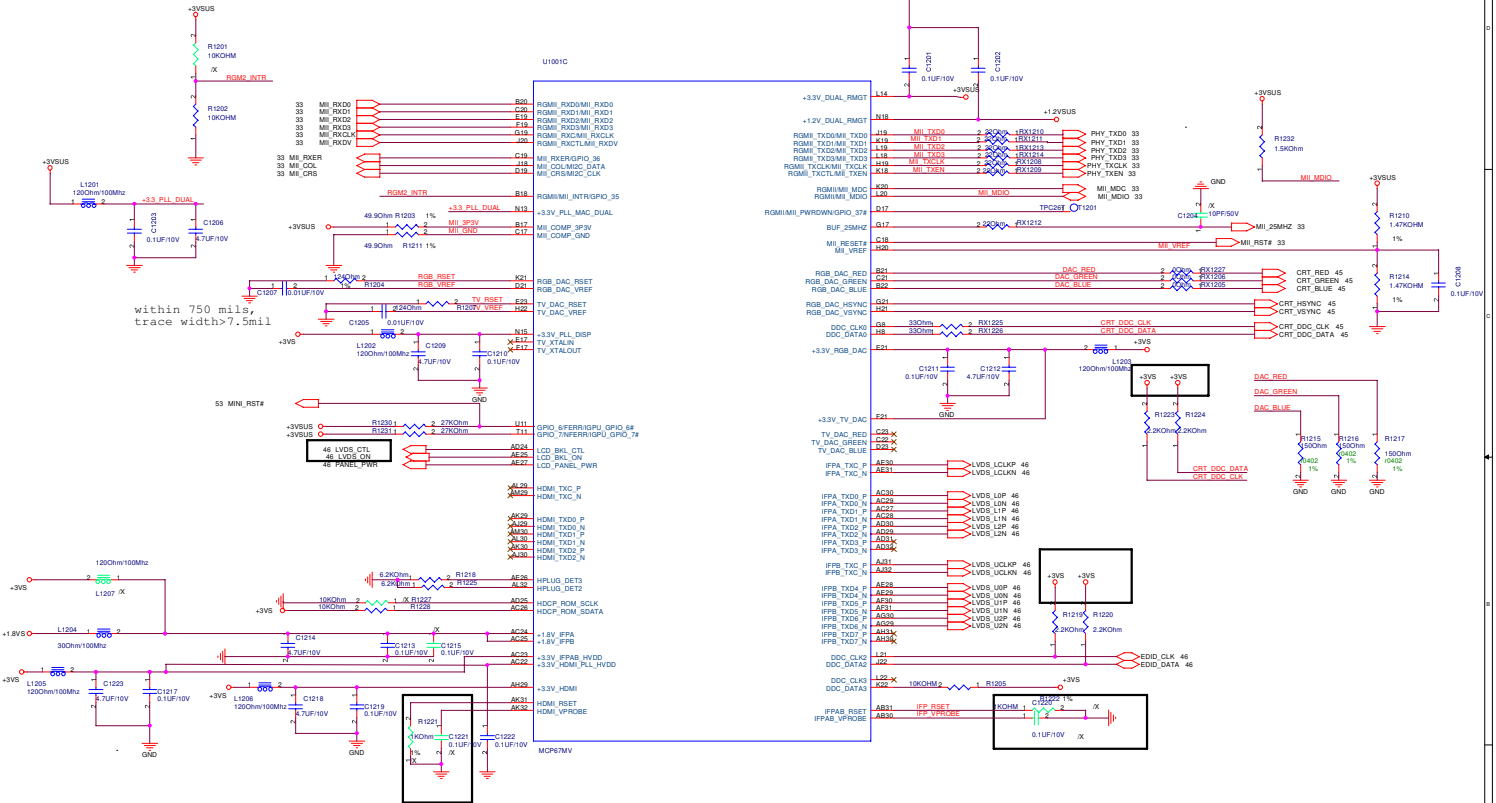

ASUS Title: FSU
ASUSTek Computer Inc. Engineer: He Wang

| Rev | Project Name | Rev |
|-----|--------------|-----|
| 1 | FSU | 1.0 |

Date: 2023-09-20 Time: 15:00:00 Sheet: 13 of 38

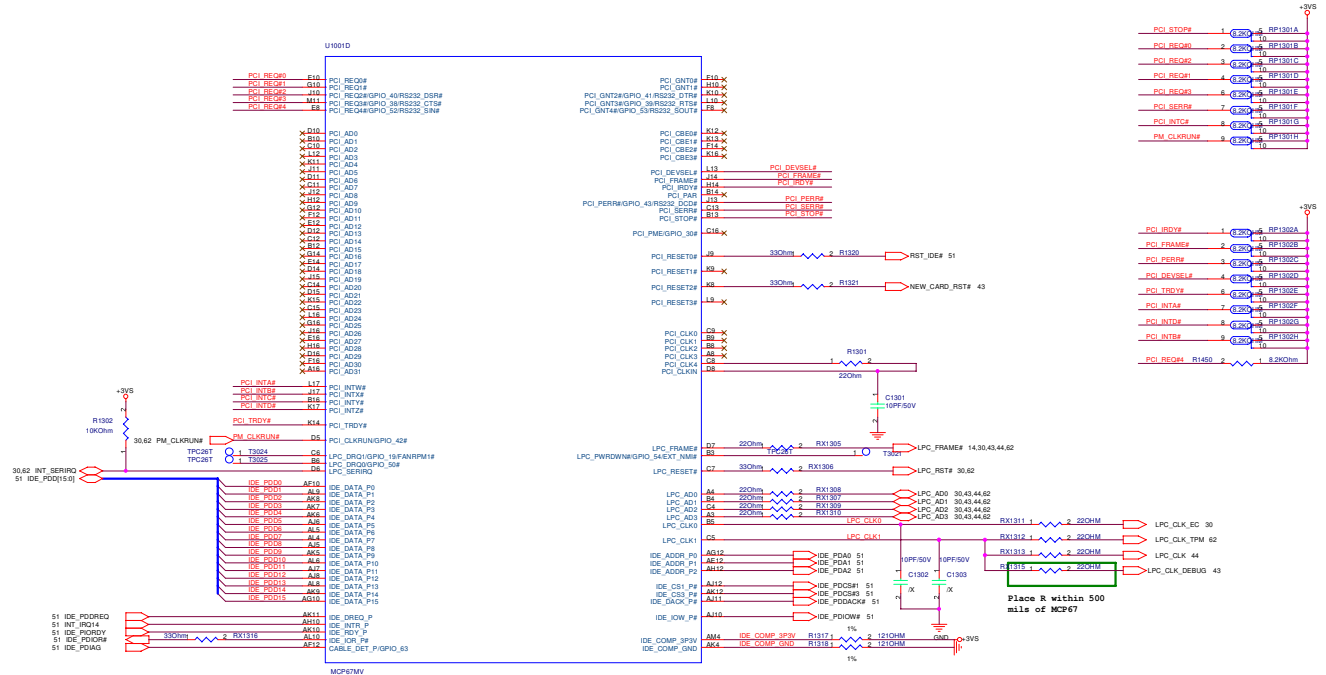

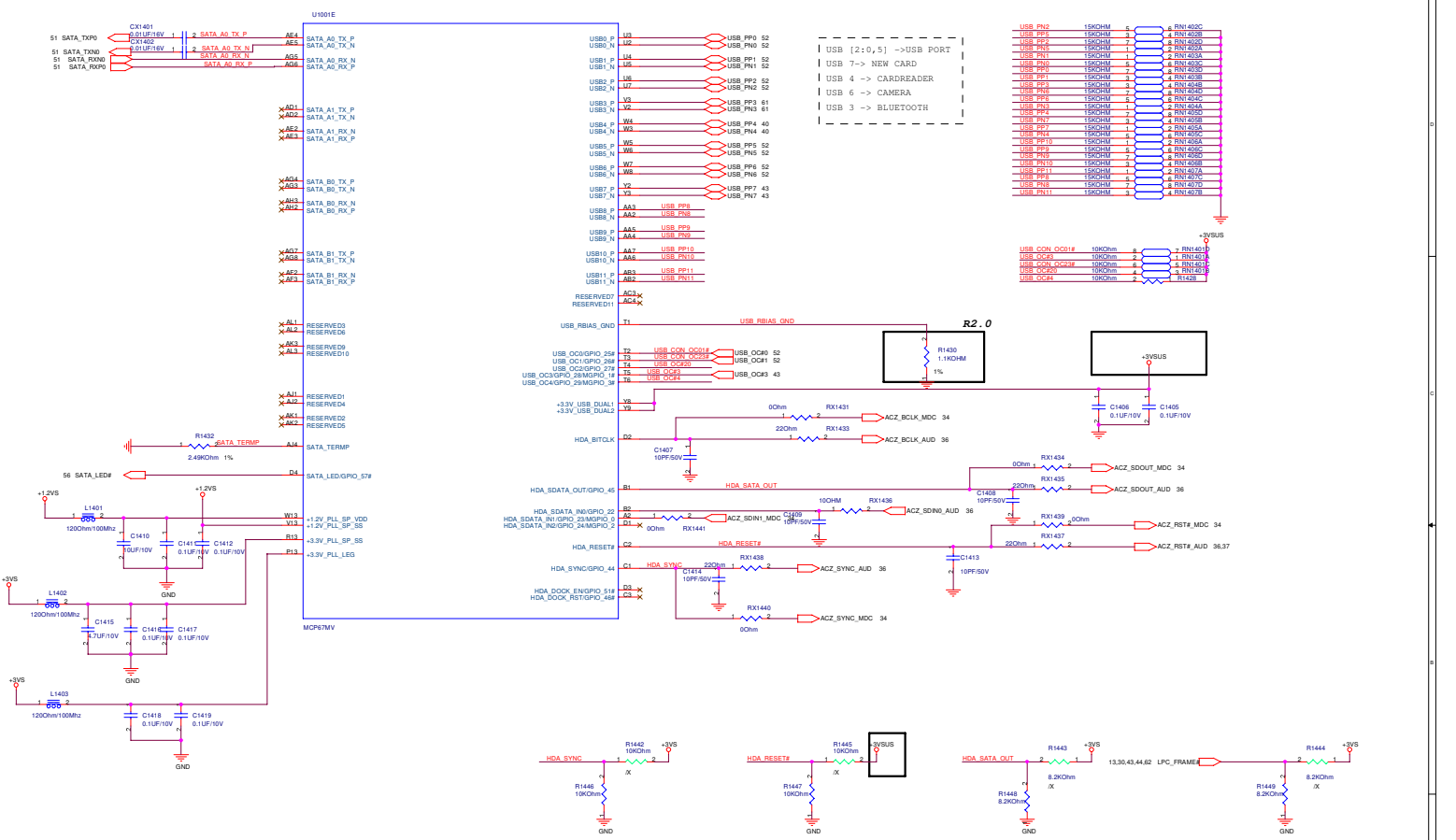

| SIO CLOCK select | |
|------------------|------------------------|
| 0 | 14.31818 MHz (Default) |
| 1 | 24 MHz |

| Networking select | |
|-------------------|------|
| 0 | MII |
| 1 | RGMI |

| BIOS Select | |
|-------------|----------|
| 00 | LPC BIOS |
| 01 | PCI BIOS |

ASUS Title : FSU
 ASUSTek Computer INC Engineer: He Wang
 Rev: 1.0
 Date: 2014-09-23 10:07 Sheet: 14 of 26

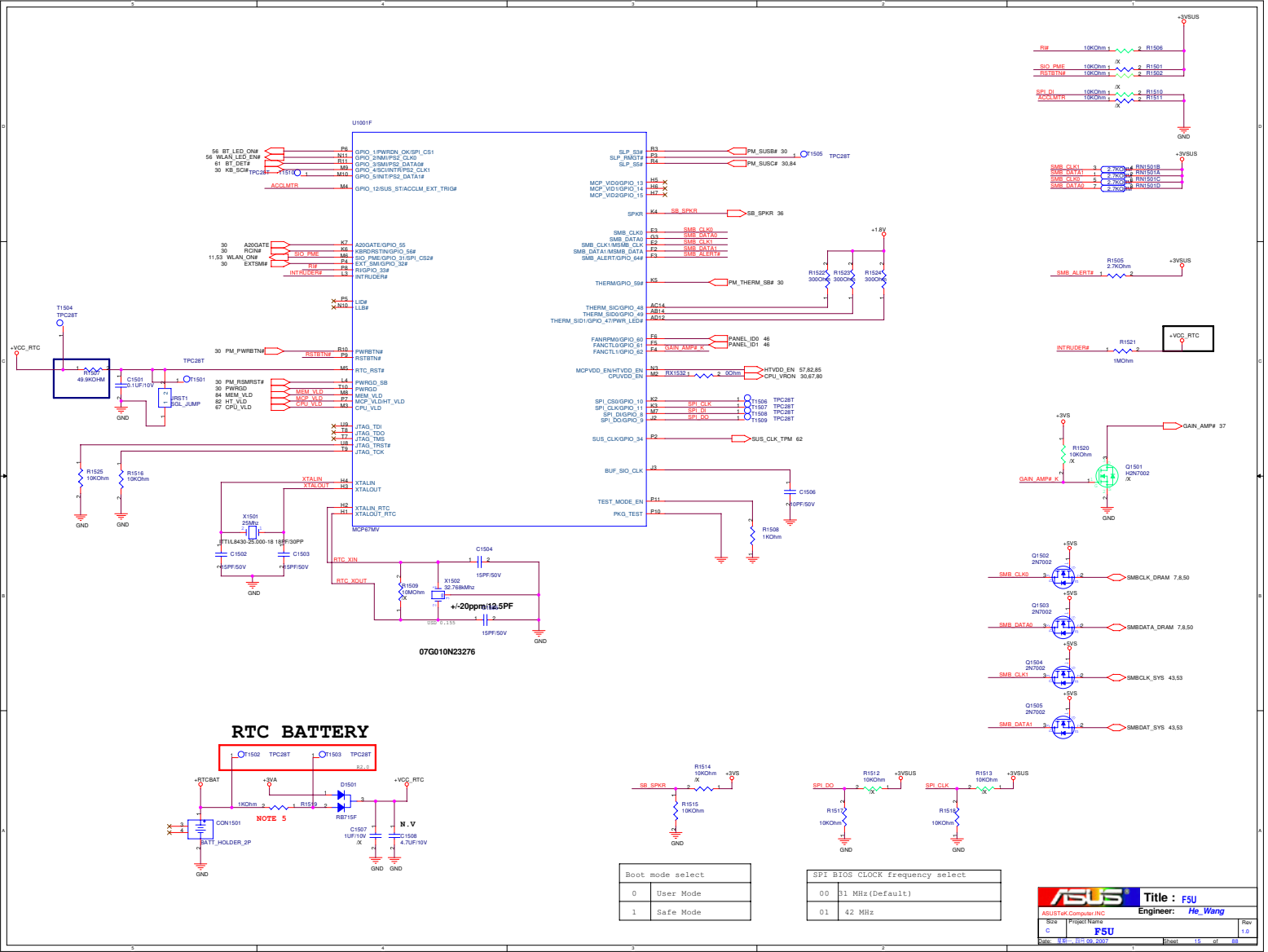

RTC BATTERY

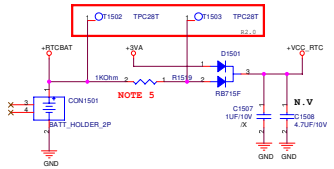

Boot mode select

| | |
|---|-----------|
| 0 | User Mode |
| 1 | Safe Mode |

SPT BIOS CLOCK frequency select

| | |
|----|------------------|
| 00 | 81 MHz (Default) |
| 01 | 42 MHz |

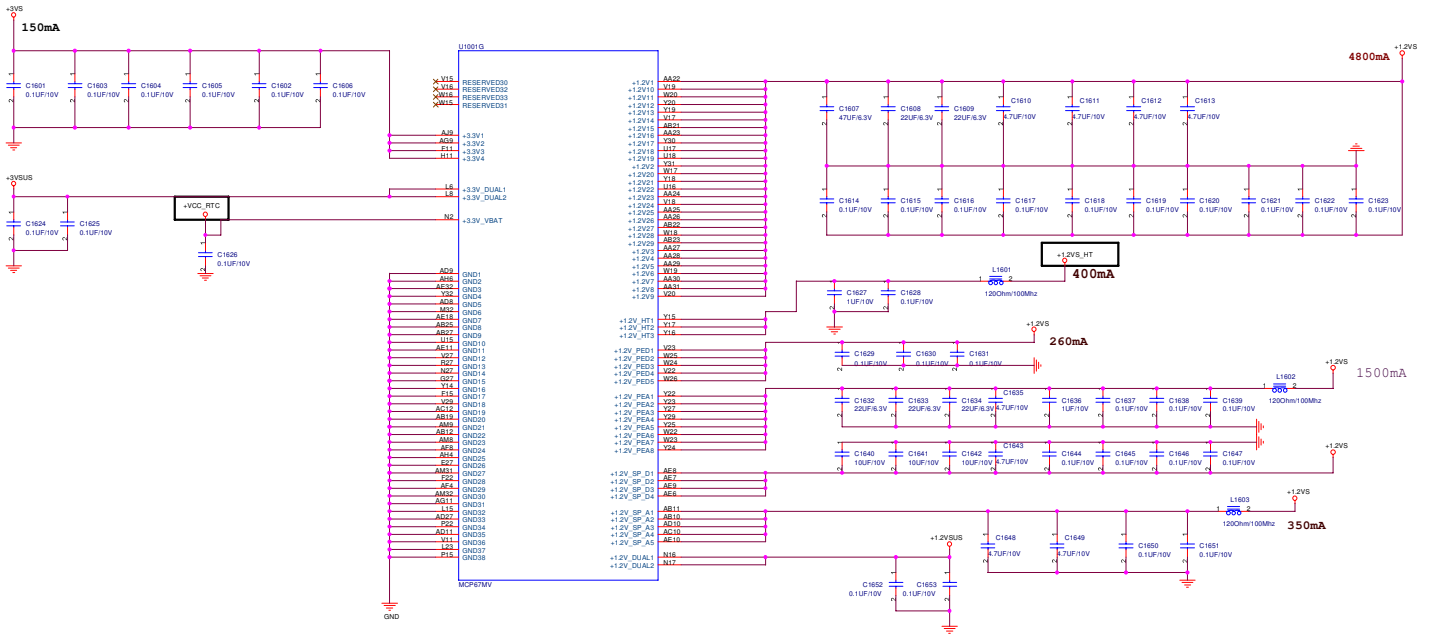

UFD01H

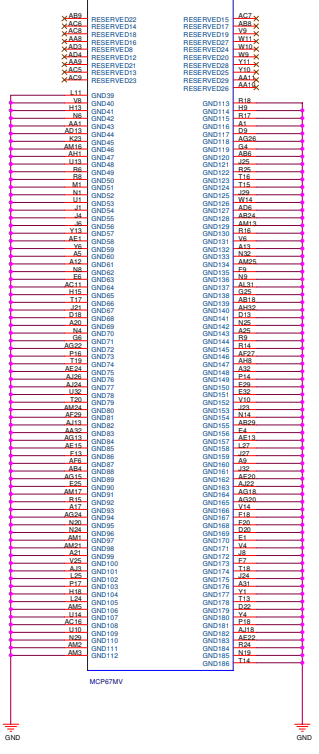



RESERVE200
RESERVE201
RESERVE202
RESERVE203
RESERVE204
RESERVE205
RESERVE206
RESERVE207
RESERVE208
RESERVE209

AC7
AC8
AC9
AC10
AC11
AC12
AC13
AC14
AC15
AC16
AC17
AC18
AC19
AC20
AC21
AC22
AC23
AC24
AC25
AC26
AC27
AC28
AC29
AC30
AC31
AC32
AC33
AC34
AC35
AC36
AC37
AC38
AC39
AC40
AC41
AC42
AC43
AC44
AC45
AC46
AC47
AC48
AC49
AC50
AC51
AC52
AC53
AC54
AC55
AC56
AC57
AC58
AC59
AC60
AC61
AC62
AC63
AC64
AC65
AC66
AC67
AC68
AC69
AC70
AC71
AC72
AC73
AC74
AC75
AC76
AC77
AC78
AC79
AC80
AC81
AC82
AC83
AC84
AC85
AC86
AC87
AC88
AC89
AC90
AC91
AC92
AC93
AC94
AC95
AC96
AC97
AC98
AC99
AC100
AC101
AC102
AC103
AC104
AC105
AC106
AC107
AC108
AC109
AC110
AC111
AC112

| | | | |
|------------------------|--------------|-------------------|-------|
| | | Title : FSU | |
| ASUSTek Computer INC | | Engineer: He Wang | |
| Size | Project Name | Rev | |
| C | FSU | | 1.0 |
| Date: 2023-05-26 10:07 | | Sheet: 17 | of 26 |

| | | | |
|---|--------------|-------------------|-------|
|  | | Title : FSU | |
| ASUSTek Computer Inc. | | Engineer: He Wang | |
| Size | Project Name | | Rev |
| C | FSU | | 1.0 |
| Date: 2011-05-26 10:07 | | Sheet: 18 | of 28 |

| | | | |
|---|--------------|-------------------|----|
|  | | Title : FSU | |
| ASUSTek Computer Inc. | | Engineer: He Wang | |
| Size | Project Name | Rev | |
| C | FSU | 1.0 | |
| Date: 2011-05-26 10:07 | Sheet: 18 | of | 28 |

| | | | |
|---|--------------|-------------------|-----|
|  | | Title : FSU | |
| ASUSTeK Computer INC. | | Engineer: He_Wang | |
| Size | Project Name | | Rev |
| C | FSU | | 1.0 |
| Date: 2011-11-28 2007 | | Sheet: 25 of 25 | |

| | | | |
|---|--------------|-------------------|-----|
|  | | Title : FSU | |
| ASUSTeK Computer INC. | | Engineer: He_Wang | |
| Size | Project Name | | Rev |
| C | FSU | | 1.0 |
| Date: 2011-11-28 2007 | | Sheet: 21 of 28 | |

| | | | |
|---|--------------|-------------------|-----|
|  | | Title : FSU | |
| ASUSTeK Computer INC. | | Engineer: He_Wang | |
| Size | Project Name | | Rev |
| C | FSU | | 1.0 |
| Date: 2011-11-28 2007 | | Sheet: 25 of 25 | |

| | | | |
|---|--------------|-------------------|-----|
|  | | Title : FSU | |
| ASUSTeK Computer INC. | | Engineer: He_Wang | |
| Size | Project Name | | Rev |
| C | FSU | | 1.0 |
| Date: 2011-11-28 2007 | | Sheet: 23 of 28 | |

| | | | |
|---|--------------|-------------------|-----|
|  | | Title : FSU | |
| ASUSTeK Computer INC. | | Engineer: He_Wang | |
| Size | Project Name | | Rev |
| C | FSU | | 1.0 |
| Date: 2011-11-28 2007 | | Sheet: 24 of 28 | |

| | | | |
|---|--------------|-------------------|-----|
|  | | Title : FSU | |
| ASUSTeK Computer INC. | | Engineer: He_Wang | |
| Size | Project Name | | Rev |
| C | FSU | | 1.0 |
| Date: 2017-11-28 20:07 | | Sheet: 25 of 25 | |

| | | | |
|---|--------------|-------------------|-----|
|  | | Title : FSU | |
| ASUSTeK Computer INC. | | Engineer: He_Wang | |
| Size | Project Name | | Rev |
| C | FSU | | 1.0 |
| Date: 2017-11-28 20:07 | | Sheet: 25 of 25 | |

| | | | |
|---|--------------|-------------------|-----|
|  | | Title : FSU | |
| ASUSTeK Computer INC. | | Engineer: He_Wang | |
| Size | Project Name | | Rev |
| C | FSU | | 1.0 |
| Date: 2011-11-28 2007 | | Sheet: 21 of 28 | |

| | | | |
|---|--------------|-------------------|-----|
|  | | Title : FSU | |
| ASUSTeK Computer INC. | | Engineer: He_Wang | |
| Size | Project Name | | Rev |
| C | FSU | | 1.0 |
| Date: 2011-11-28 2007 | | Sheet: 25 of 25 | |

| | | | |
|---|--------------|-------------------|-----|
|  | | Title : FSU | |
| ASUSTeK Computer INC. | | Engineer: He_Wang | |
| Size | Project Name | | Rev |
| C | FSU | | 1.0 |
| Date: 2011-11-28 2007 | | Sheet: 25 of 25 | |

For IT8511 Core IC

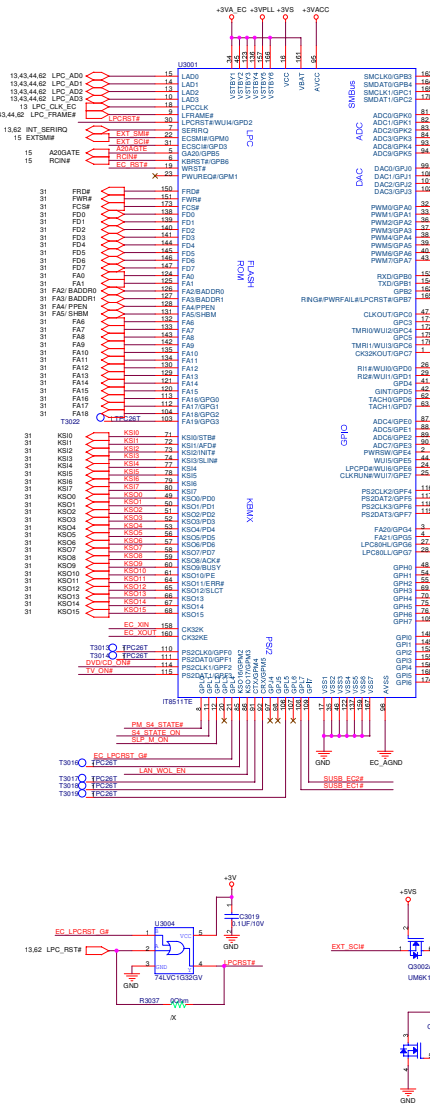

For Pull-up/Pull-down

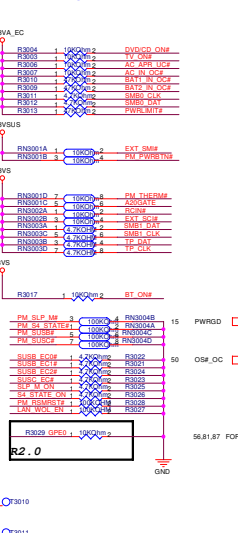

For IT8511 Power

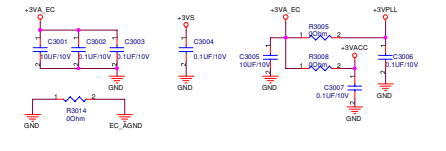

For Xtal

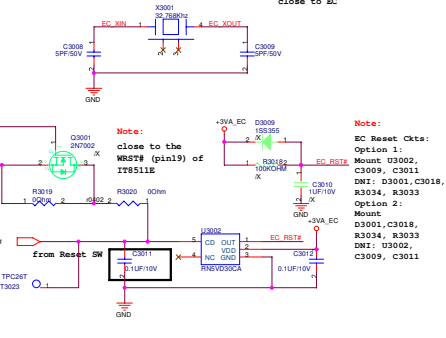

For Instant Key

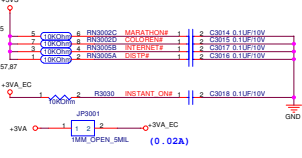

For Instant Key

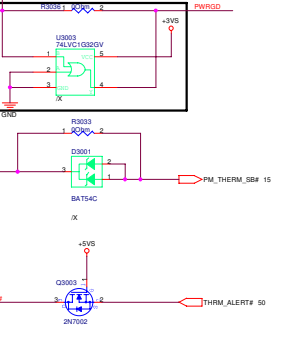

KBC connector

ISA ROM (4Mbits)

SST-PLCC32 4Mbits Flash ROM
 PN:05G001014110
 (FLASH SST S3239VF040-70-4C-NHE
 4M-70 PLCC-32)

If need to use 8Mbits ISA ROM, could choose SST39LF080.
 But it does not have PLCC32 package.
 ASUS does not have part number yet.

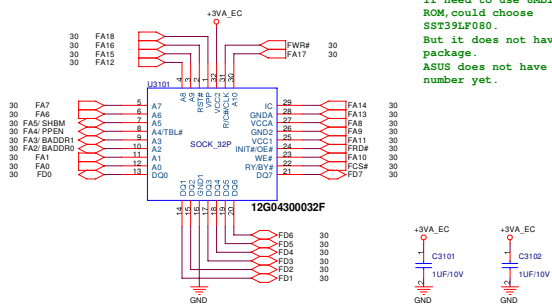

CON3101

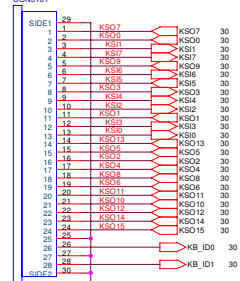

FFC_CON 28P
 12G182402806

| | | | |
|------|----|----|----|
| TYPE | JP | UK | US |
| KID1 | H | H | L |
| KID2 | L | H | L |

ISA ROM

EC Hardware Strapping

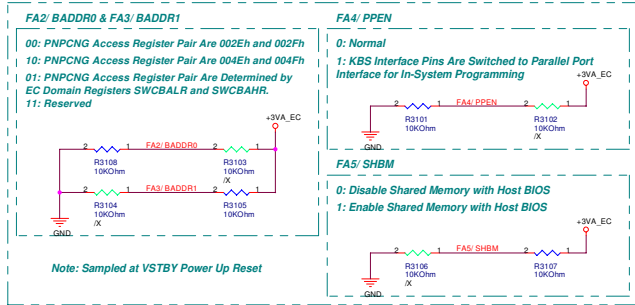

Note: Sampled at VSTBY Power Up Reset

| | | | |
|---|--------------|-------------------|-------|
|  | | Title : FSU | |
| ASUSTek Computer Inc. | | Engineer: He Wang | |
| Size | Project Name | | Rev |
| C | FSU | | 1.0 |
| Date: 2023-05-25 10:07 | | Sheet: 01 | of 01 |

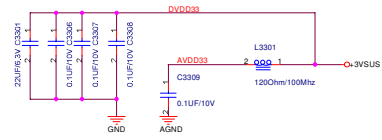

It should be RTL8201CL, 02G61120141

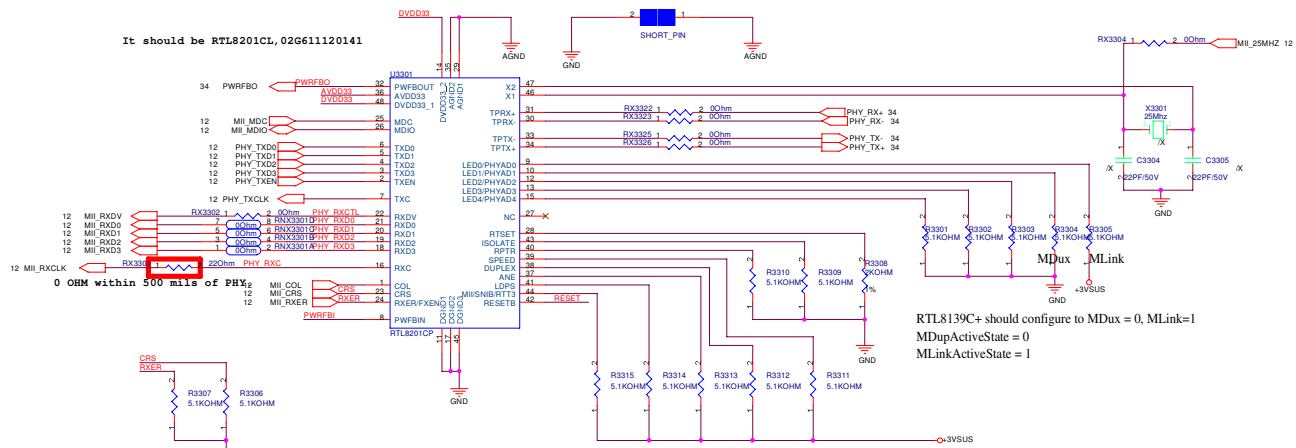

RTL8139C+ should configure to MDux = 0, MLink=1
 MDupActiveState = 0
 MLinkActiveState = 1

- ISOLATE: set high to isolate the RTL8201CP from the MAC this will also isolate the MC/MDIO managemet interface
- RPTR: set high to put the TRL8201CP into repeater mode
- SPEED: this pin is latched to input during a power on or reset condition. set high to put the RTL8201CP into 100Mbps operation
- DUPLEX: Set high to enable full duplex
- ANE: Set high to enable auto-negotiation mode, set low to force mode
- LDPS: set high to put the RTL8201CP into LDPS mode
- MII/SNIB: pull high to set the RTL8201CP into MII mode operation. set low for SNI mode

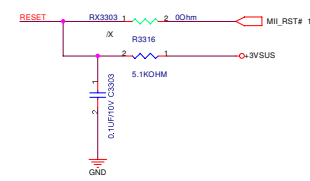
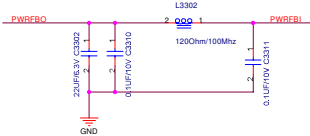

LAN PORT

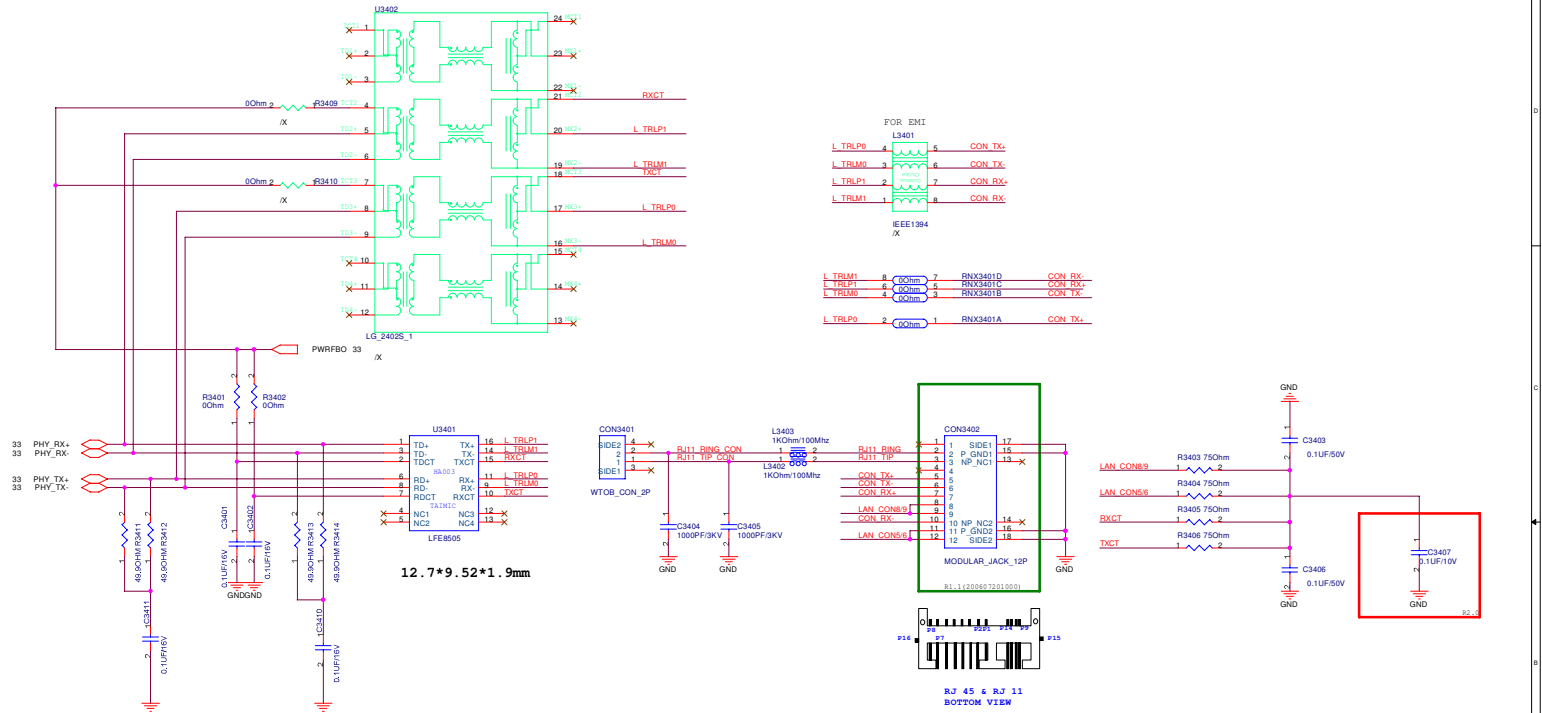

MDC CONN.

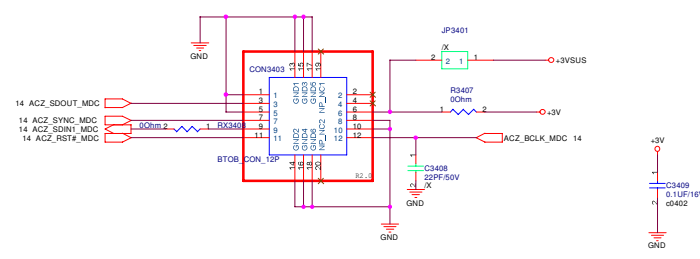

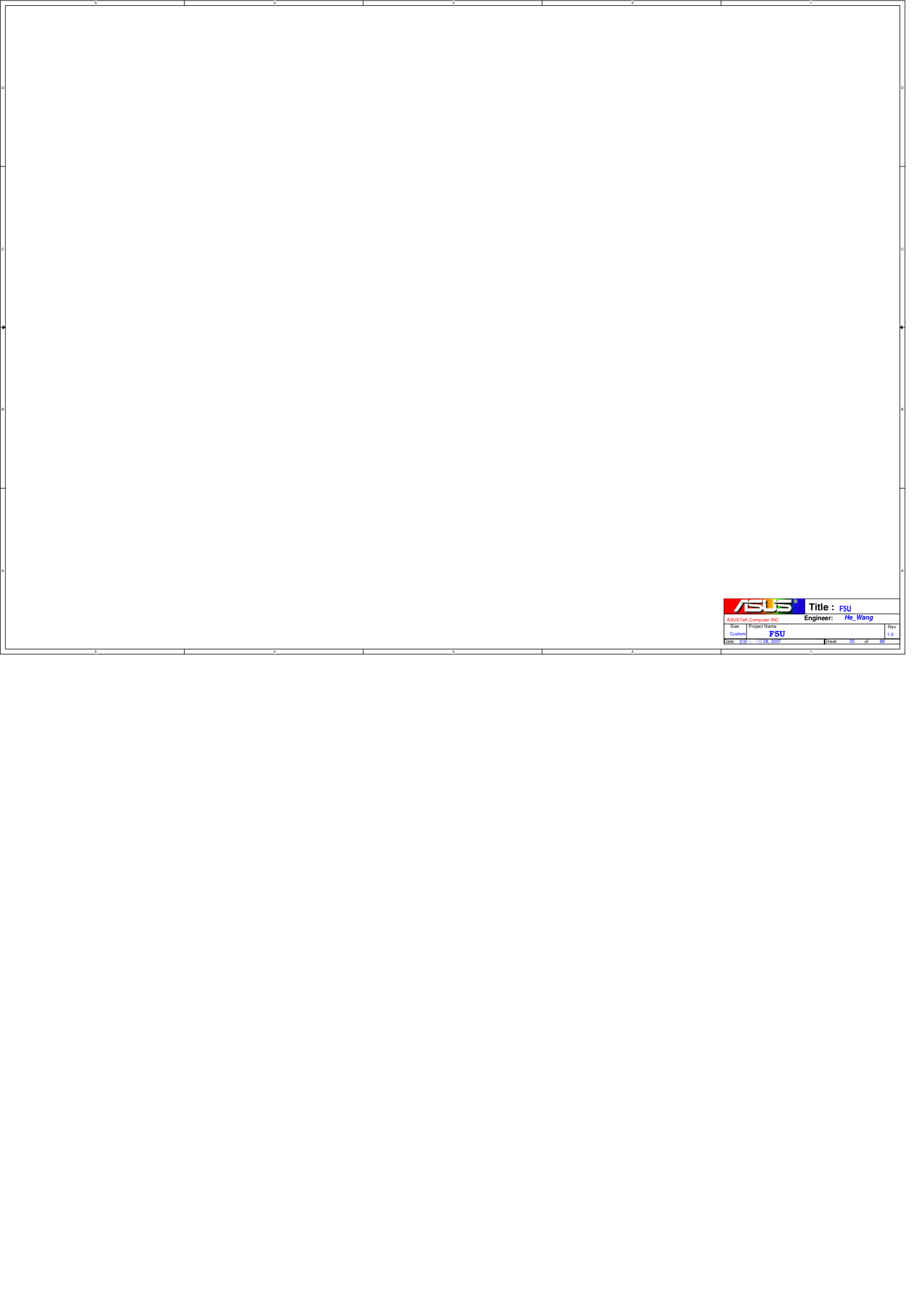

| | | |
|---|--------------|--------------------------|
|  | | Title : FSU |
| ASUS Tek Computer INC | | Engineer: He_Wang |
| Size | Project Name | Rev |
| Custom | FSU | 1.0 |
| Site: 010-11-28-2007 | | Sheet 05 of 08 |

AUDIO CODEC

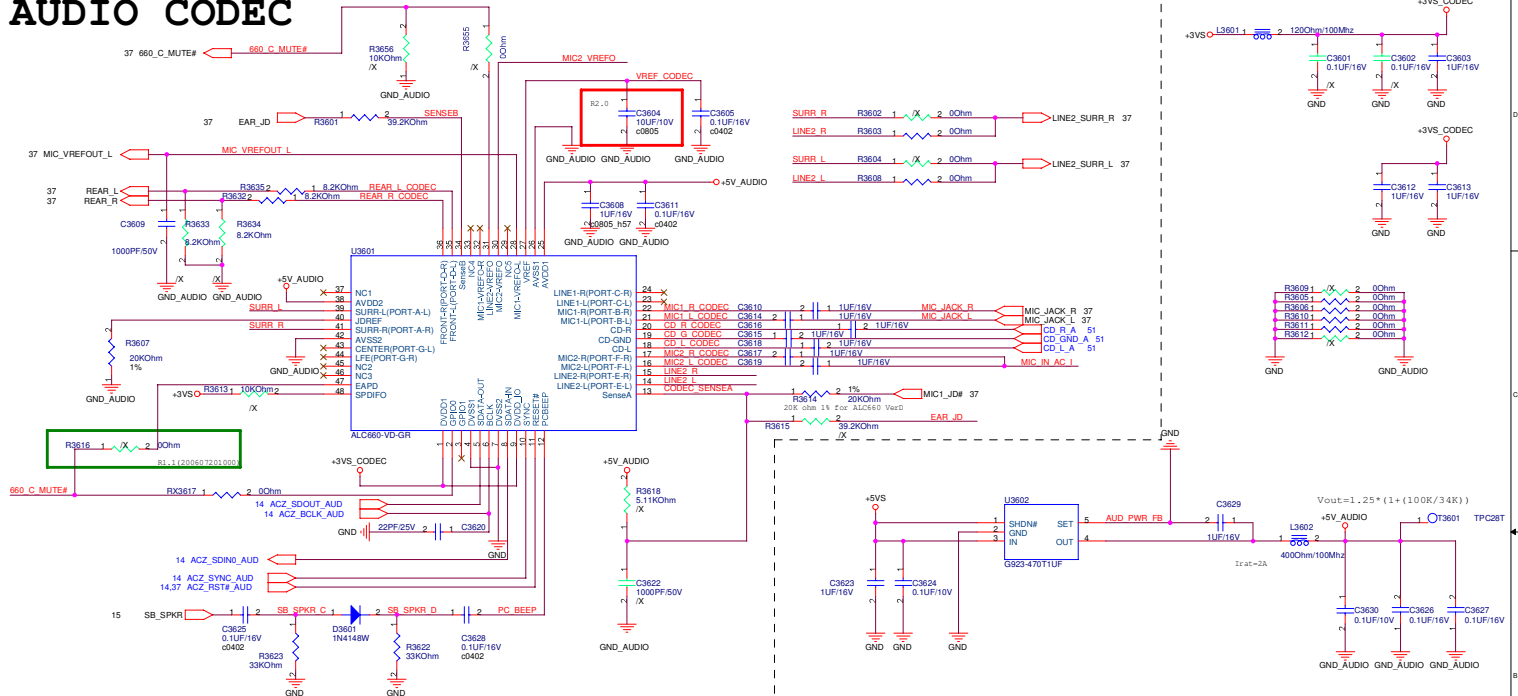

Internal MIC Pre-Amplifier

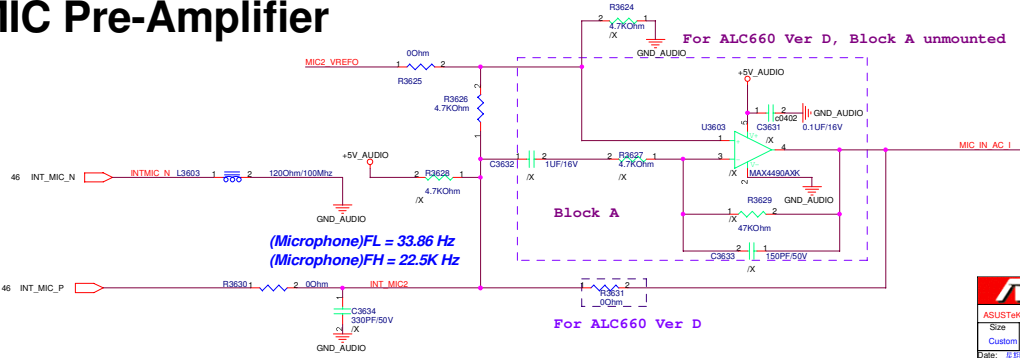

| | | | |
|-----------------------|--------------|--------------------|-------|
| ASUS | | Title : FSU | |
| ASUSTek Computer, INC | | Engineer: He_Wang | |
| Size | Project Name | | Rev |
| Custom | FSU | | 1.0 |
| Date: 11/09/2007 | Sheet | 36 | of 38 |

AUDIO AMPLIFIER

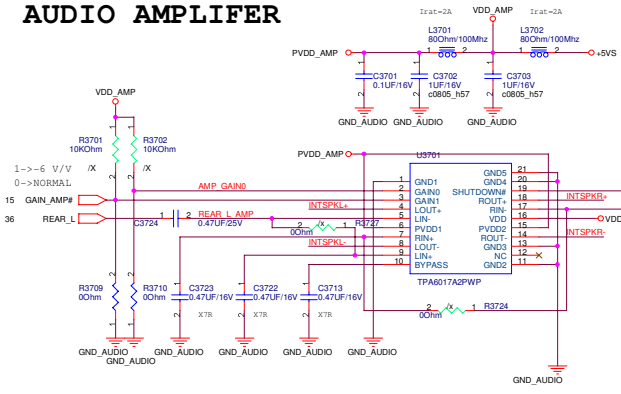

SPEAKER

To Internal Speaker Connector

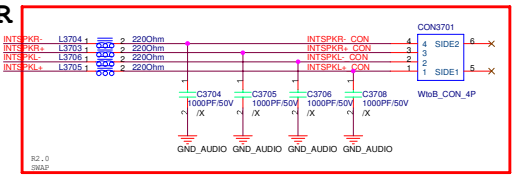

HeadPhone

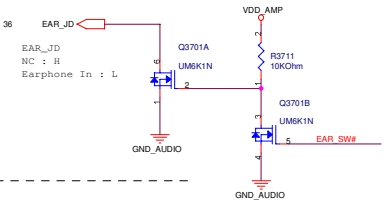

DEPOP CIRCUIT

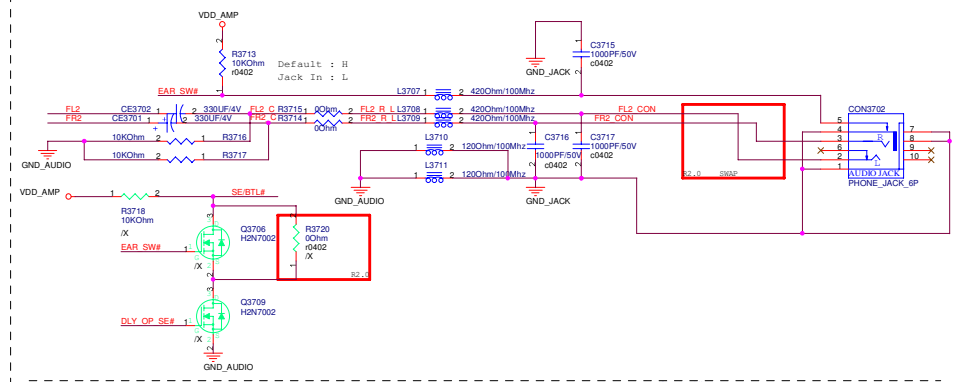
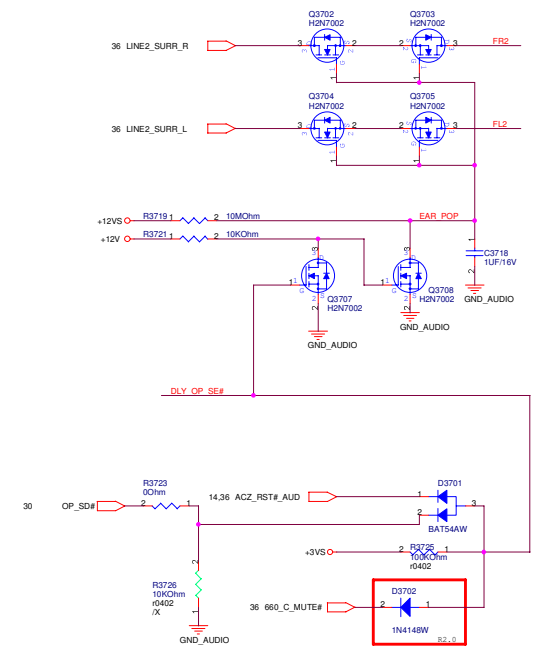

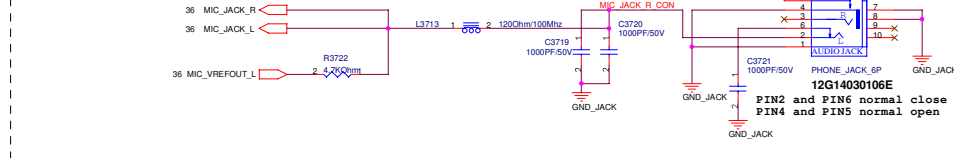

External Microphone

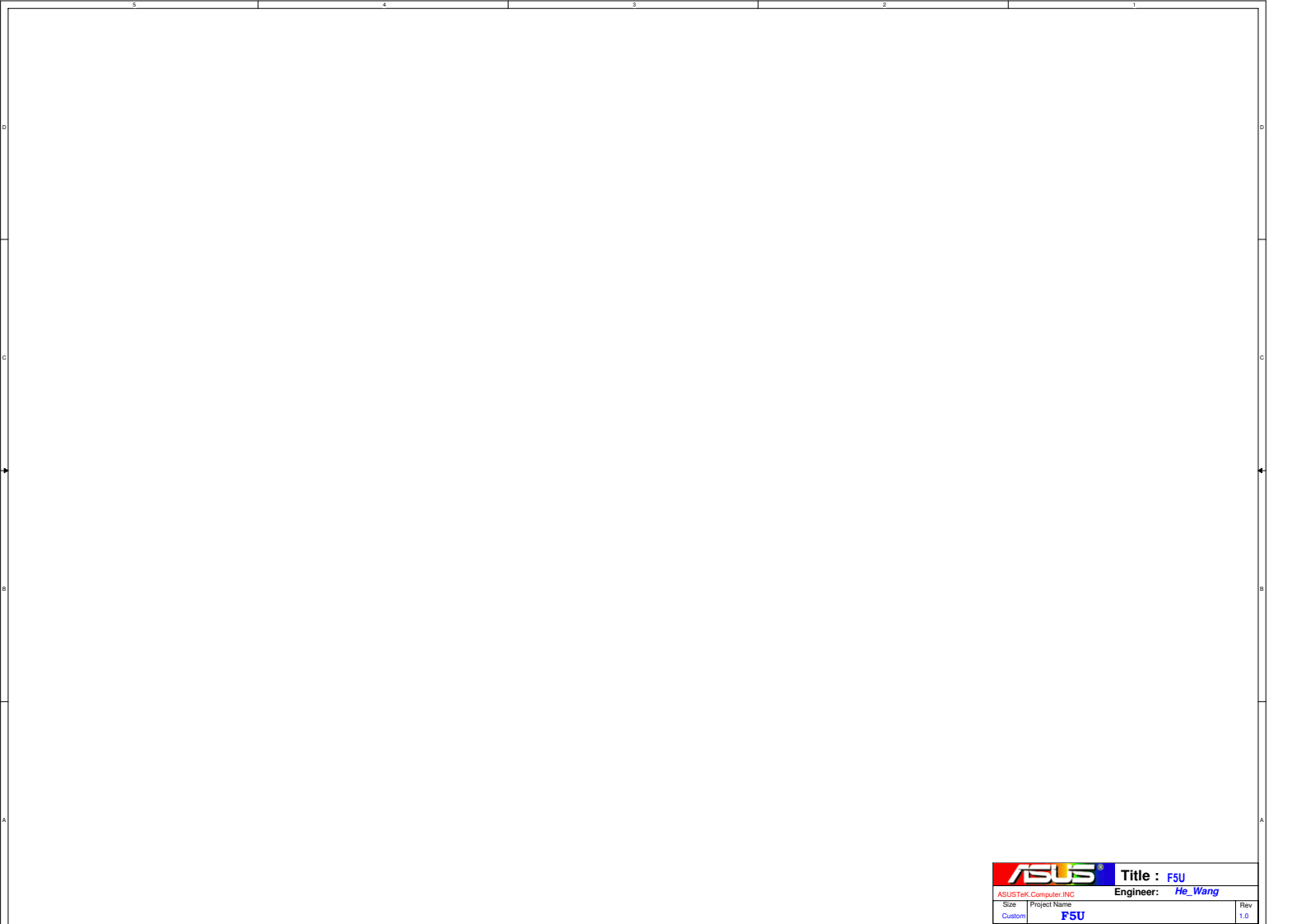

ASUS Title : FSU
 ASUSTeK Computer, INC Engineer: He_Wang
 Size Project Name
 Custom FSU
 Date: 11/19/09 2007 Sheet 37 of 38



| | | | |
|---|--------------|--------------------------|----------|
|  | | Title : FSU | |
| ASUSTeK Computer INC | | Engineer: He_Wang | |
| Size | Project Name | | Rev |
| Custom | FSU | | 1.0 |
| Date: 2007-11-28 | | Sheet | 38 of 38 |

| | | | |
|---|--------------|-------------------|-------|
|  | | Title : FSU | |
| ASUSTek Computer Inc. | | Engineer: He Wang | |
| Size | Project Name | Rev | |
| C | FSU | 1.0 | |
| Date: 2011-05-25 10:07 | Sheet: 01 | | of 01 |

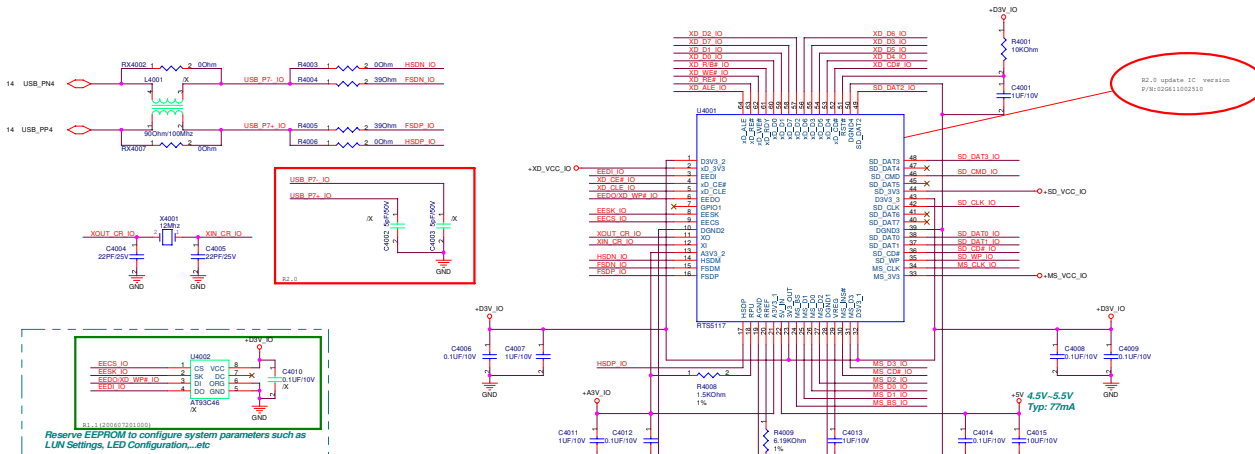

BIOS update IC version
P/N:0261100210

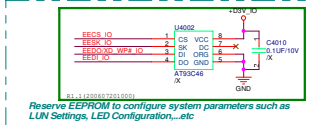
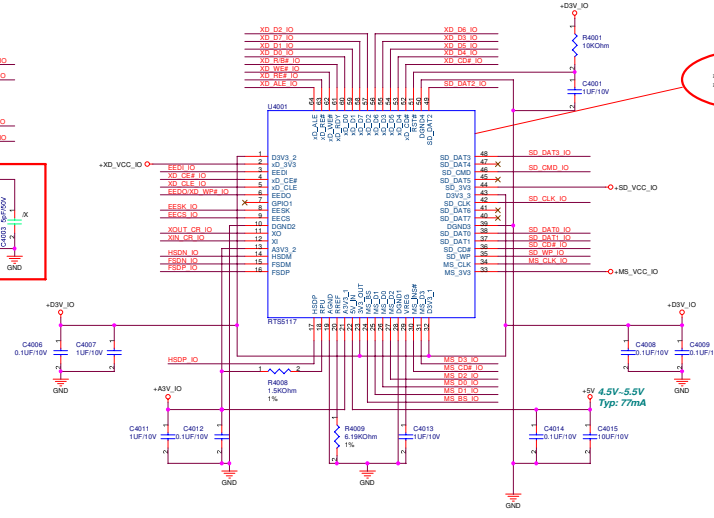

Reserve EEPROM to configure system parameters such as LUN Settings, LED Configuration...etc

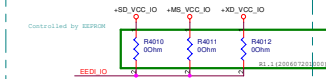



| | R2910 | R2911 |
|---|----------|----------|
| SD/MMC only | No Stuff | No Stuff |
| xD/SD/MMC/MS/MS-Pro Combo Support CPU C3 State | No Stuff | 4.7K |
| SD/MMC/MS/MS-Pro Combo Don't Support CPU C3 State | 4.7K | No Stuff |
| SD/MMC/MS/MS-Pro Combo Don't Support CPU C3 State | 4.7K | 4.7K |

IO_R41 should be present if system doesn't use EEPROM to configure LED.

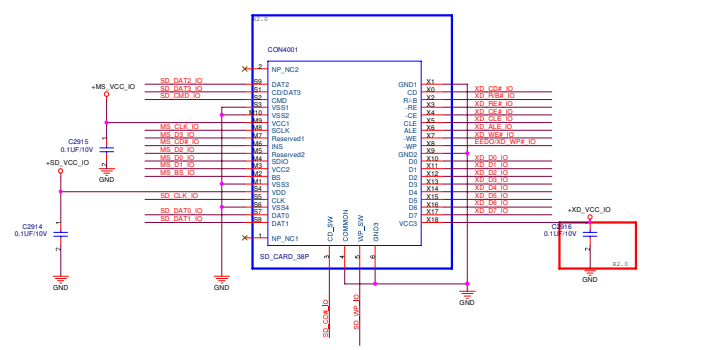
Through these pull-high resistors, EEPROM can be saved if no other requirement about other parameters.

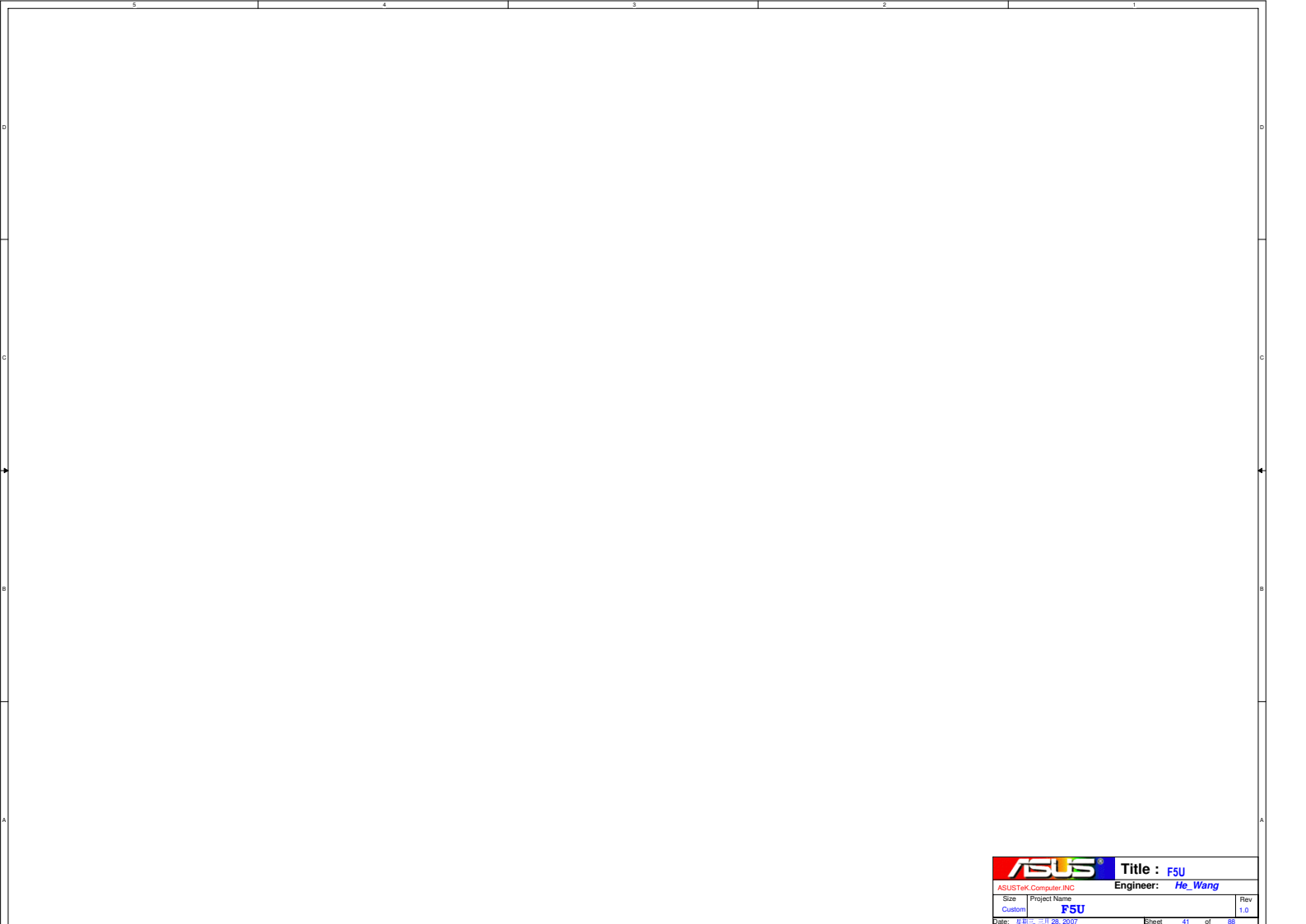



| | | |
|---|--------------|--------------------------|
|  | | Title : FSU |
| ASUSTeK Computer INC | | Engineer: He_Wang |
| Size | Project Name | Rev |
| Custom | FSU | 1.0 |
| Date: 11/23/2007 | Sheet | 41 of 88 |

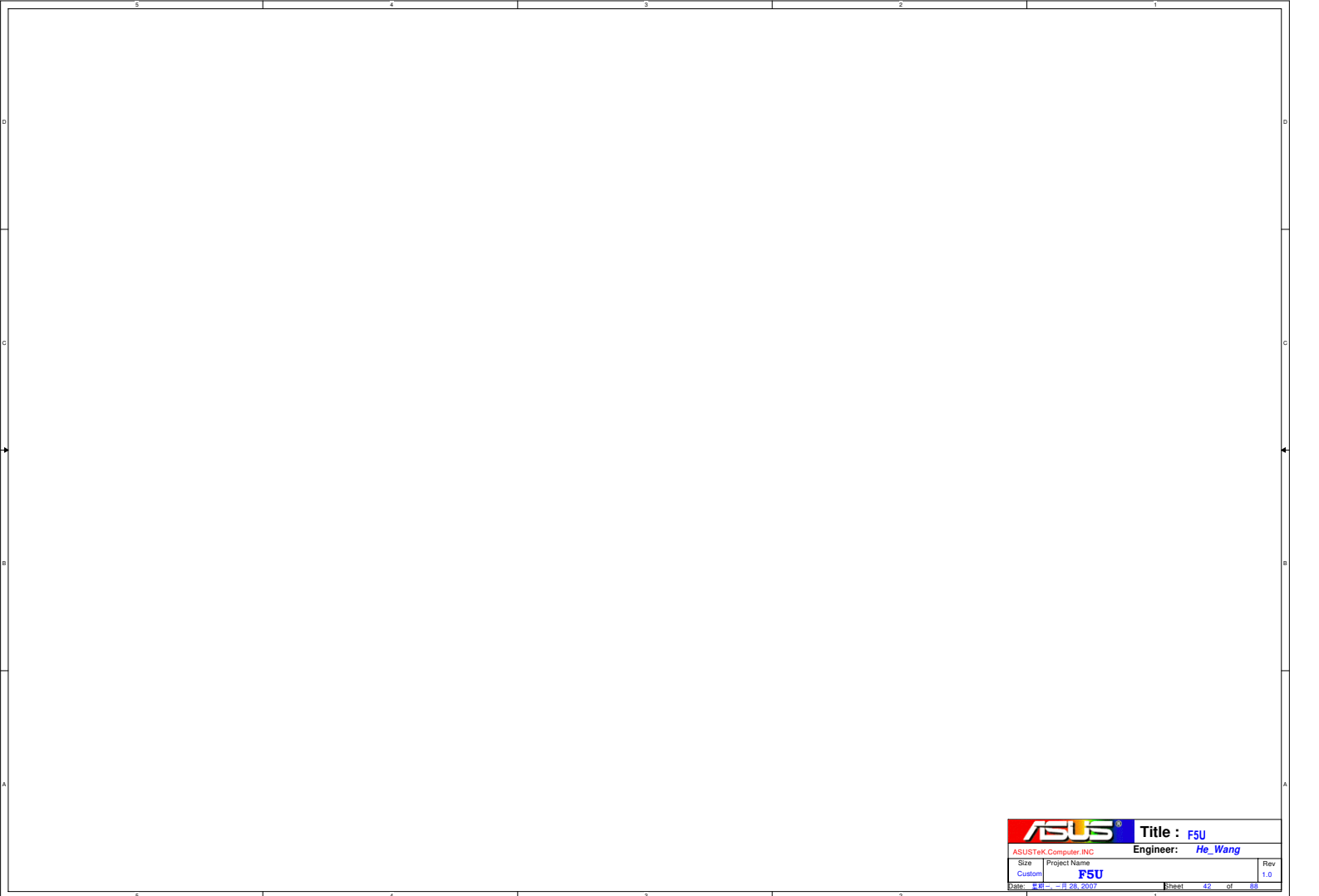

| | | | |
|--|----------------|--------------------------|---|
|  | | Title : FSU | |
| ASUSTeK Computer INC | | Engineer: He_Wang | |
| Size | Project Name | Rev | |
| Custom | FSU | 1.0 | |
| Date: 08-28-2007 | Sheet 42 of 68 | | 1 |

NEW CARD SOCKET

!! ExpressCard Standard 1.0:
 Change Pin7 from RESERVED to SMBCLK
 Change Pin8 from SMBCLK to SMBDATA
 Change Pin9 from SMBDATA to +1.5V

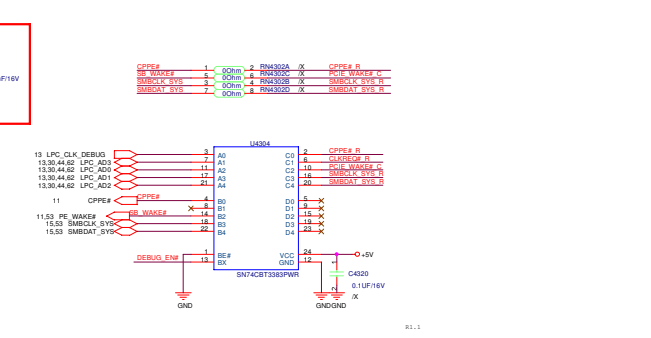
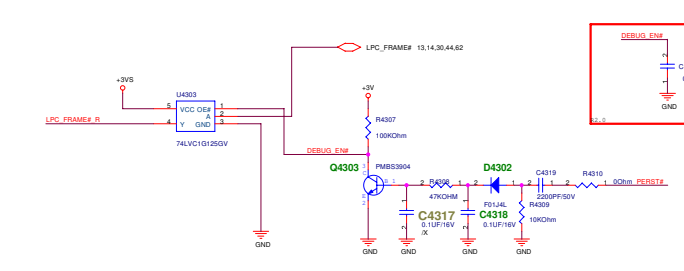
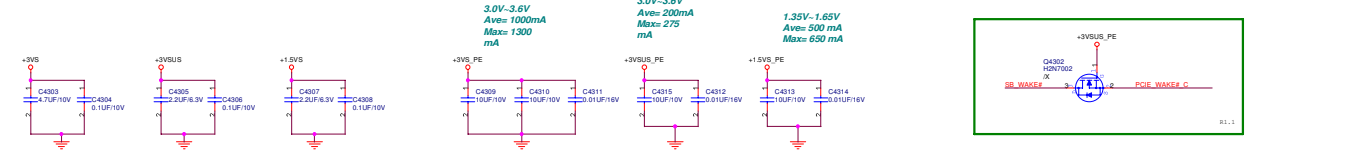
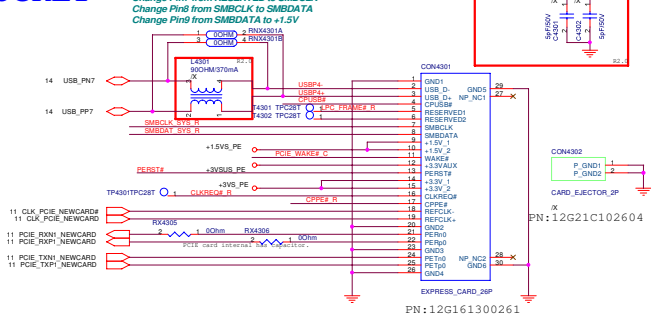
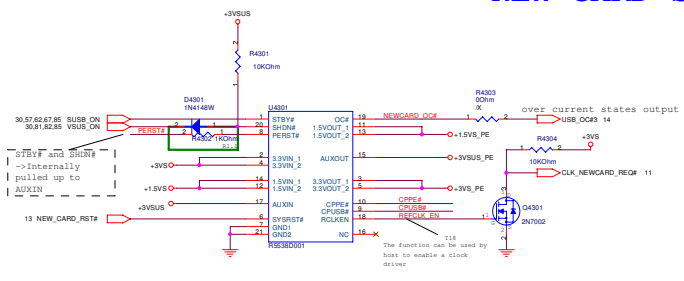

LPC DEBUG CONNECTOR

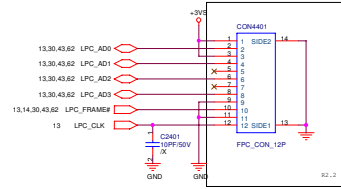

VGA OUT

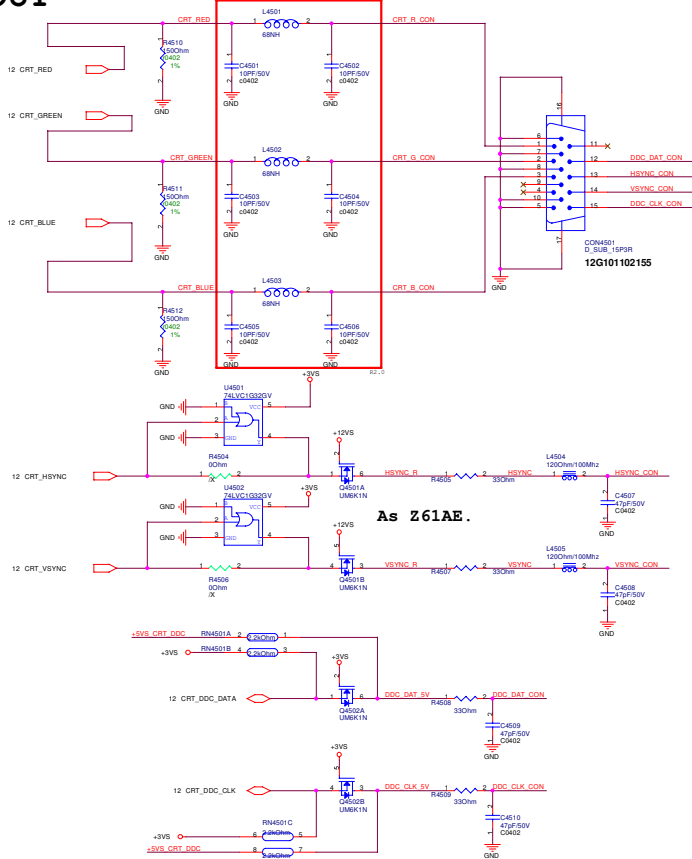

As Z61AE.

PLACE ESD Diodes near VGA port

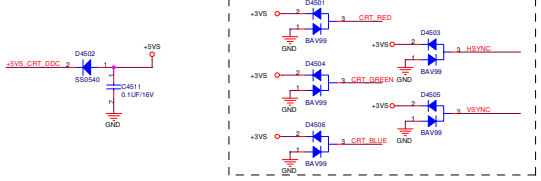

LCD Power

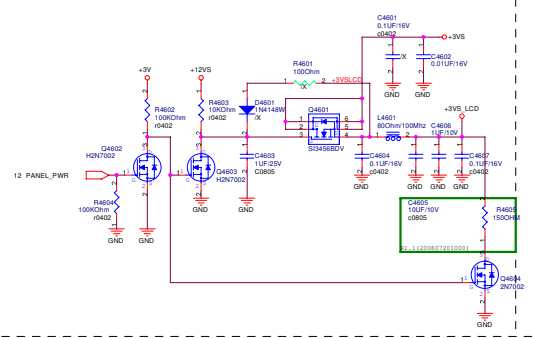

LCD LVDS Interface

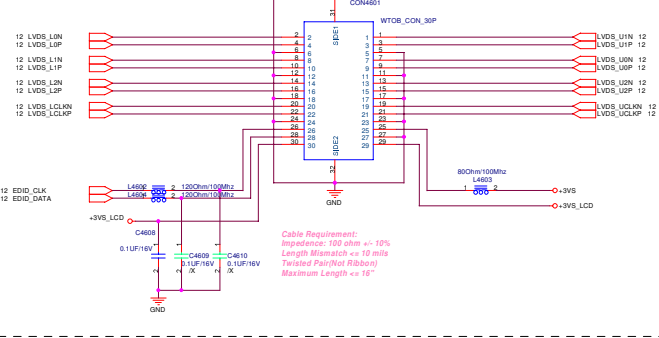

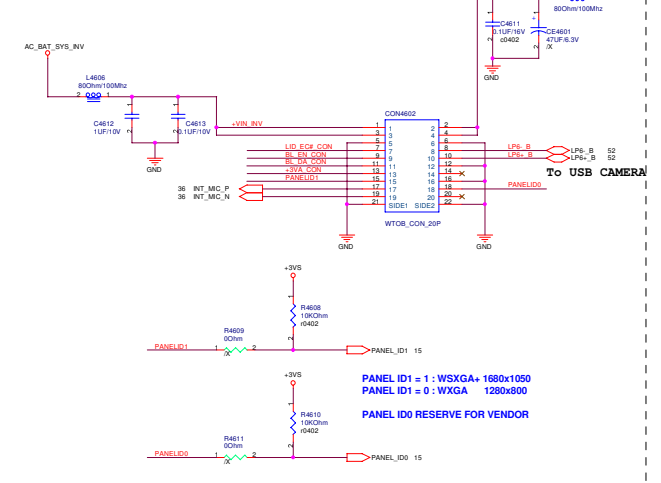

INVERTER Interface



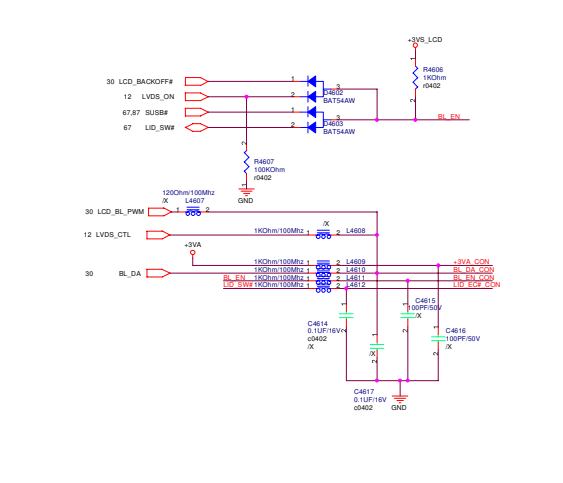

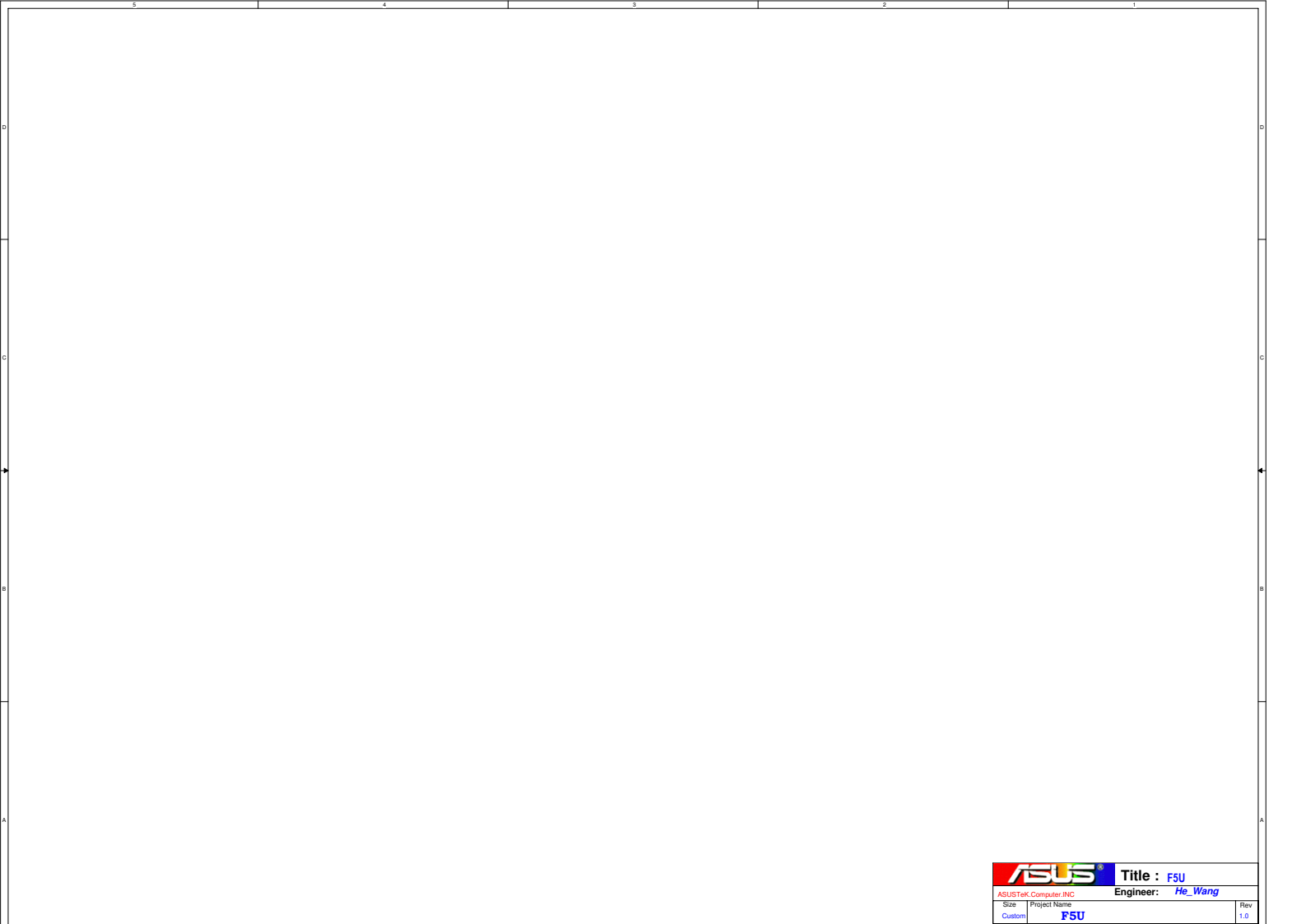
Backlight Enable





| | | | |
|---|--------------|--------------------------|----------|
|  | | Title : FSU | |
| ASUSTeK Computer INC | | Engineer: He_Wang | |
| Size | Project Name | | Rev |
| Custom | FSU | | 1.0 |
| Date: 2007-08-28 | | Sheet | 47 of 88 |

| | | | |
|---|--------------|--------------------------|-----|
|  | | Title : FSU | |
| ASUSTek Computer Inc. | | Engineer: He Wang | |
| Size | Project Name | Rev | |
| C | FSU | | 1.0 |
| Date: 2023-09-29 10:07 | Sheet: 48 | of | 88 |

| | | | |
|---|--------------|-------------------|-------|
|  | | Title : FSU | |
| ASUSTek Computer Inc. | | Engineer: He Wang | |
| Size | Project Name | | Rev |
| C | FSU | | 1.0 |
| Date: 2023-09-26 10:07 | | Sheet: 49 | of 50 |

DC FAN control

-----OTHER SIGNALS
 15 mils
 -----GND
 10 mils
 -----NB_THRM_DA(10 mils)
 10 mils
 -----NB_THRM_DC(10 mils)
 10 mils
 -----GND
 15 mils
 -----OTHER SIGNALS
 Avoid FSB,Power

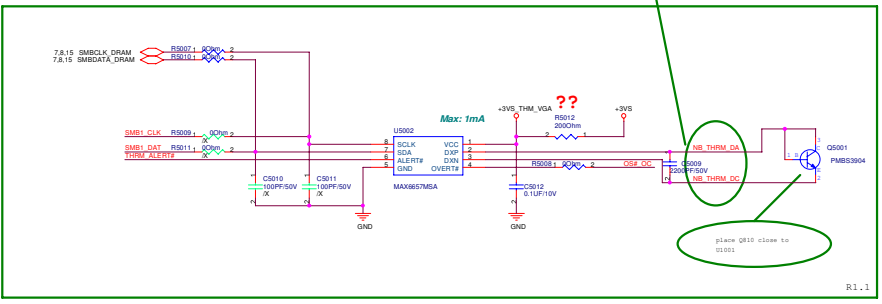
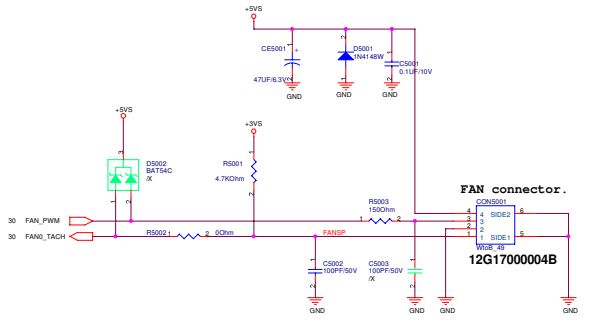

Thermal Sensor

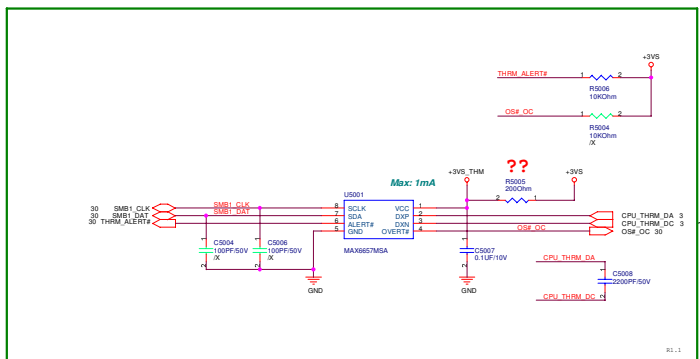

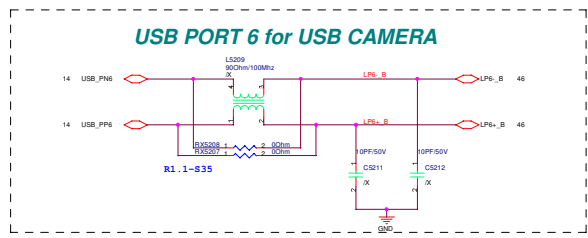
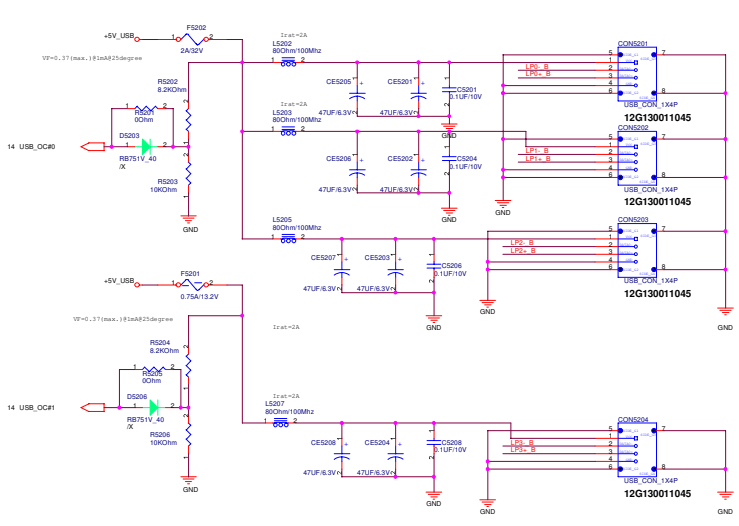
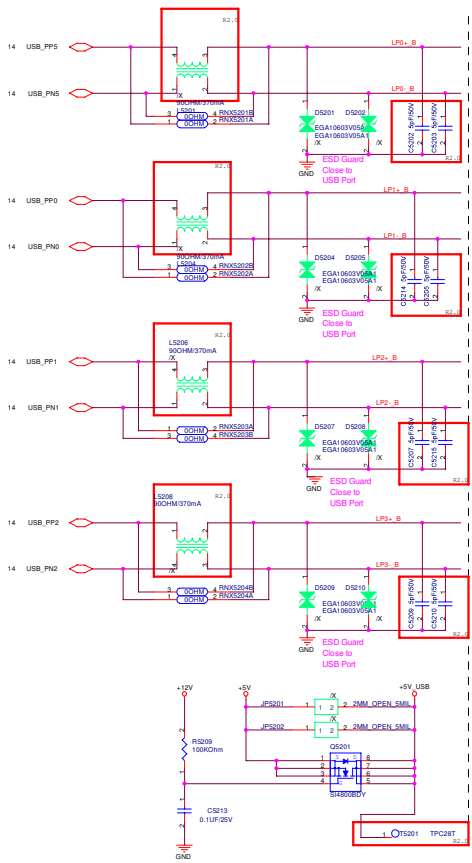

Route CPU_THRM_DA and CPU_THRM_DC on the same layer
 15 mils
 -----GND
 10 mils
 -----H_THERMDA(10 mils)
 10 mils
 -----H_THERMDC(10 mils)
 15 mils
 -----GND
 -----OTHER SIGNALS
 Avoid FSB,Power

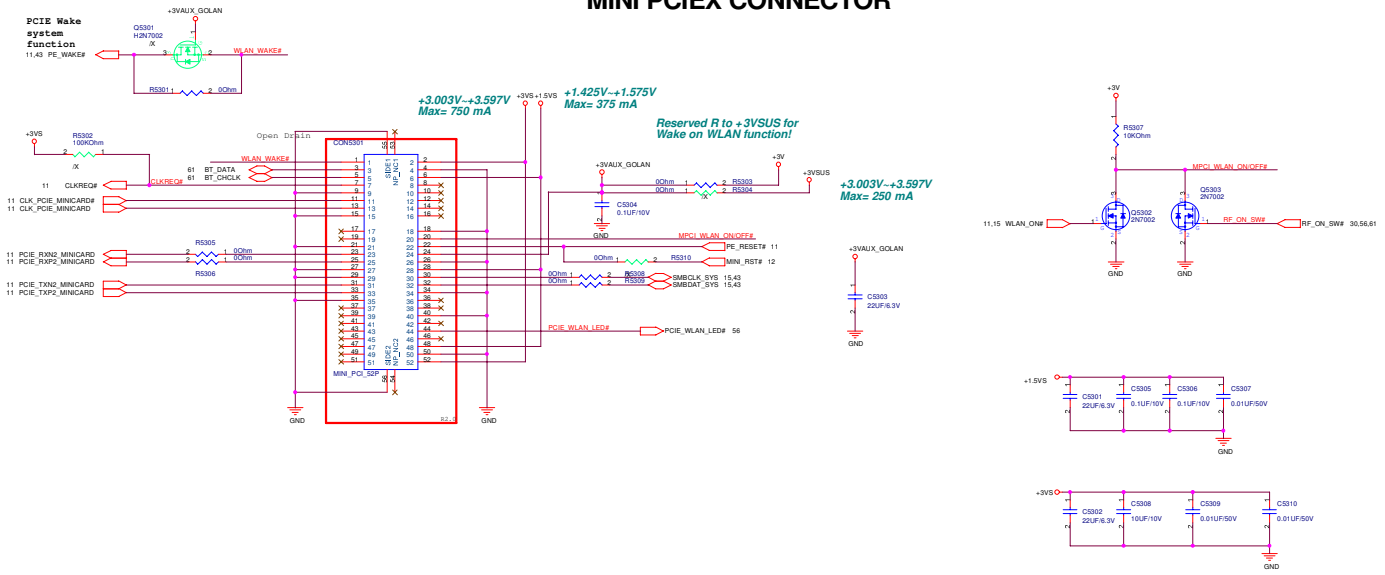

MINI PCIEX CONNECTOR



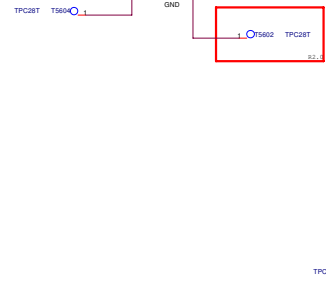
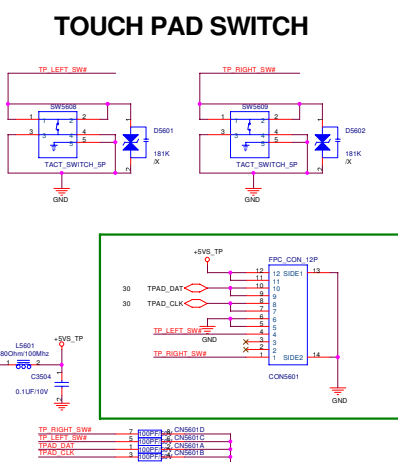
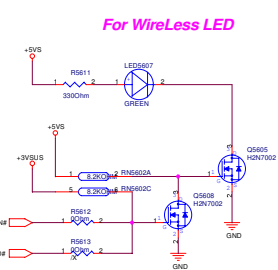
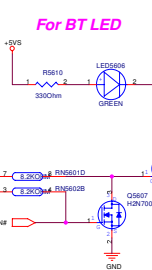
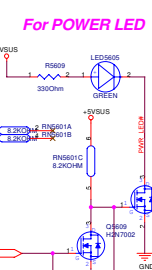
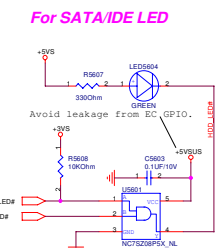
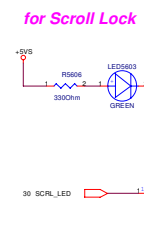
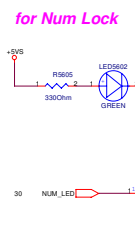
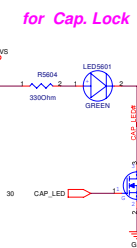
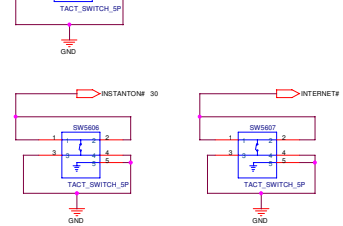
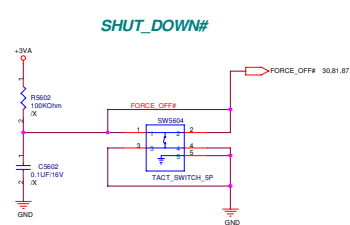
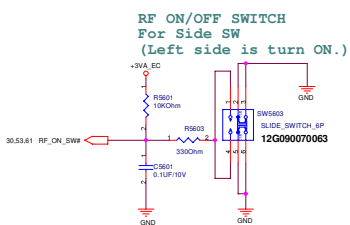
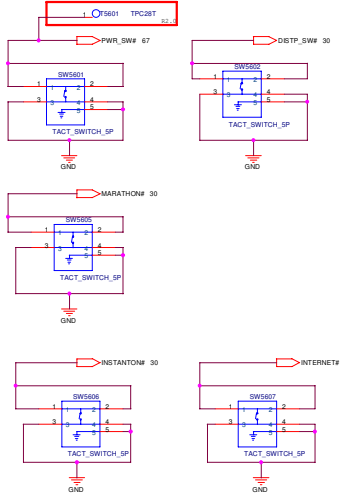

| | | | |
|---|--------------|--------------------------|----|
|  | | Title : FSU | |
| ASUSTek Computer Inc. | | Engineer: He Wang | |
| Size | Project Name | Rev | |
| C | FSU | 1.0 | |
| Date: 2011-05-26 10:07 | Sheet: 54 | of | 58 |

| | | | |
|---|--------------|-------------------|-------|
|  | | Title : FSU | |
| ASUSTek Computer Inc. | | Engineer: He Wang | |
| Size | Project Name | | Rev |
| C | FSU | | 1.0 |
| Date: 2011-05-26 10:07 | | Sheet: 05 | of 05 |

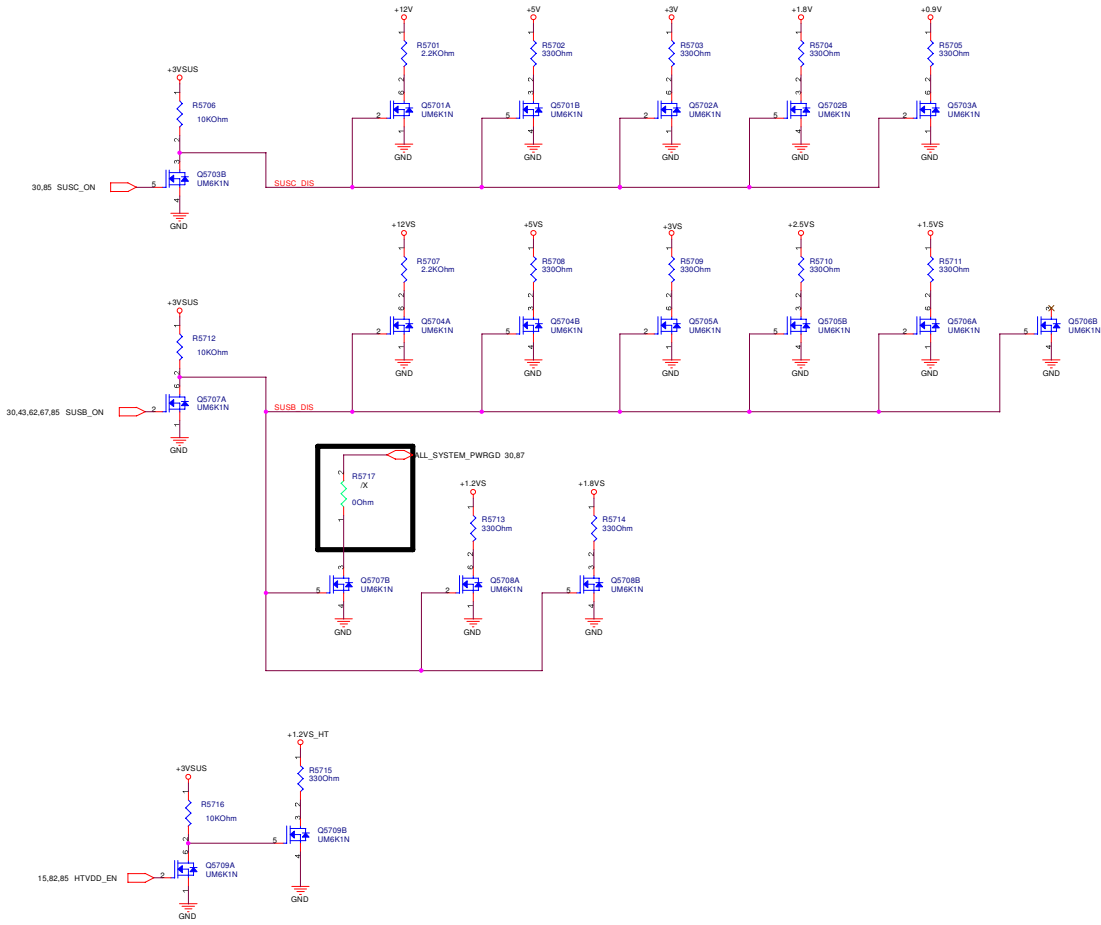

DISCHARGE CIRCUIT



| | | | |
|---|--------------|-------------------|-------|
|  | | Title : FSU | |
| ASUSTek Computer Inc. | | Engineer: He Wang | |
| Size | Project Name | | Rev |
| C | FSU | | 1.0 |
| Date: 2011-05-25 10:07 | | Sheet: 01 | of 01 |

| | | | |
|---|--------------|--------------------------|-----|
|  | | Title : FSU | |
| ASUSTek Computer Inc. | | Engineer: He Wang | |
| Size | Project Name | Rev | |
| C | FSU | | 1.0 |
| Date: 2011-03-29 10:07 | Sheet: 01 | of | 01 |

Adaptor IN Circuit

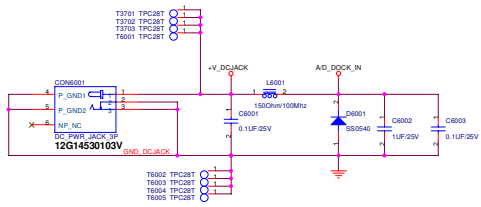

BATTERY IN CIRCUIT

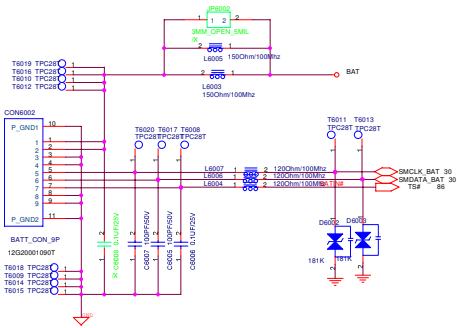

BLUETOOTH CONNECTOR

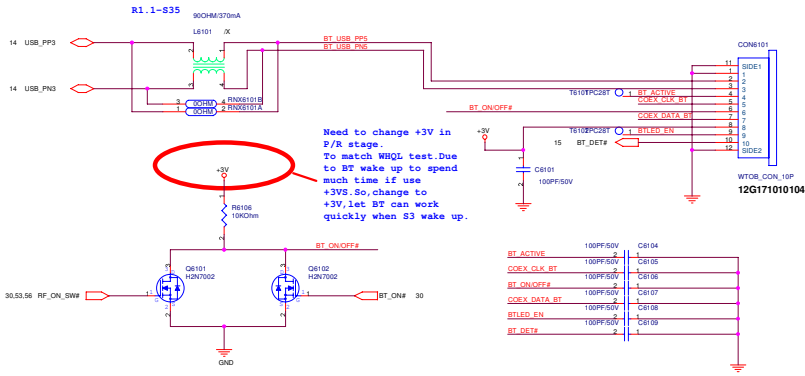

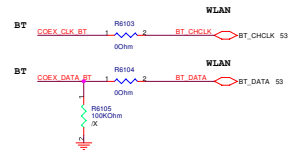
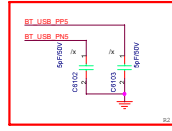

Signal direction-
CLK: BT -> WLAN;
DATA: WLAN -> BT



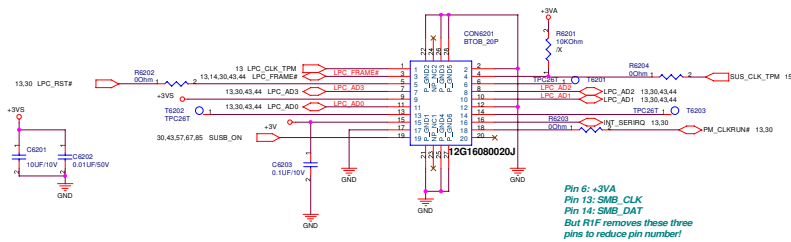

TPM CONN.



| | | | |
|---|--------------|-------------------|-------|
|  | | Title : FSU | |
| ASUSTek Computer Inc. | | Engineer: He Wang | |
| Size | Project Name | | Rev |
| C | FSU | | 1.0 |
| Date: 2011-05-26 10:07 | | Sheet: 61 | of 66 |

| | | | |
|---|--------------|-------------------|-------|
|  | | Title : FSU | |
| ASUSTek Computer Inc. | | Engineer: He Wang | |
| Size | Project Name | | Rev |
| C | FSU | | 1.0 |
| Date: 2011-03-29 10:07 | | Sheet: 64 | of 68 |

| | | | |
|---|--------------|-------------------|-------|
|  | | Title : FSU | |
| ASUSTek Computer Inc. | | Engineer: He Wang | |
| Size | Project Name | | Rev |
| C | FSU | | 1.0 |
| Date: 2011-05-25 10:07 | | Sheet: 65 | of 65 |

| | | | |
|---|--------------|-------------------|-------|
|  | | Title : FSU | |
| ASUSTeK Computer INC. | | Engineer: He Wang | |
| Size | Project Name | | Rev |
| C | FSU | | 1.0 |
| Date: 2011-05-25 10:07 | | Sheet: 01 | of 01 |

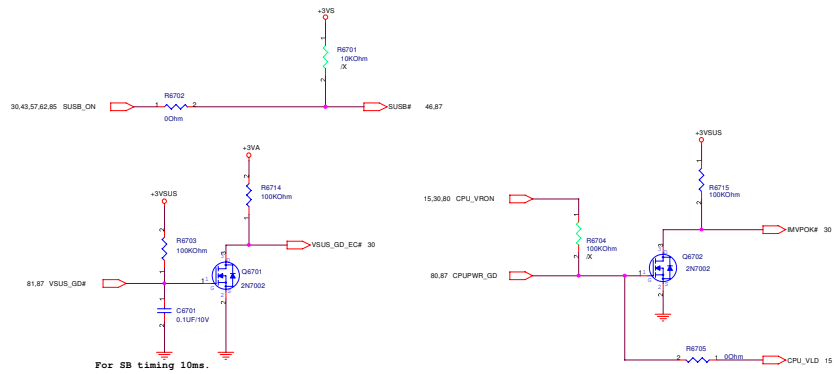

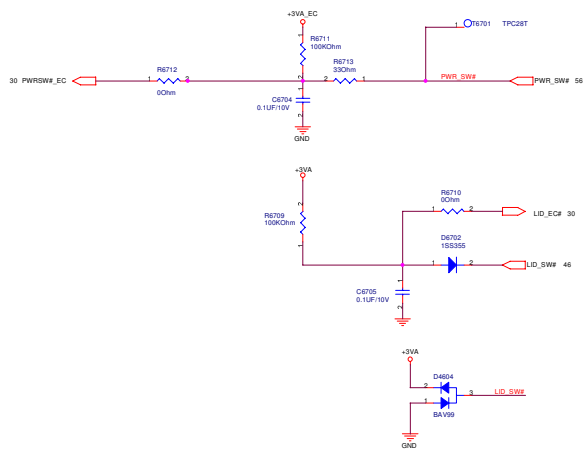

POWER SWITCH



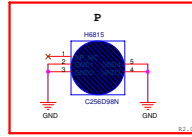
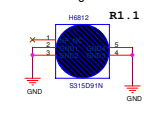
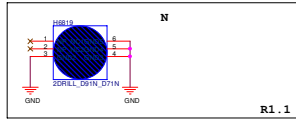
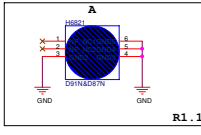
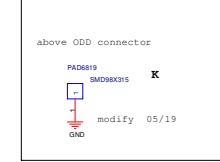
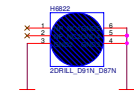
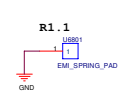
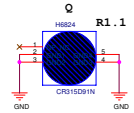
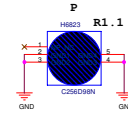
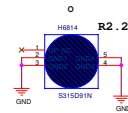
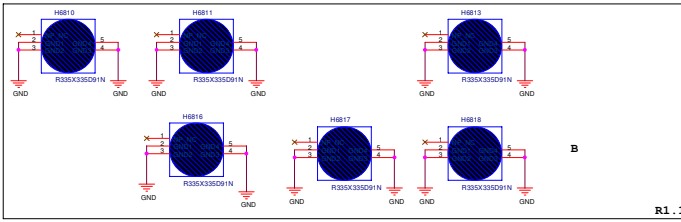
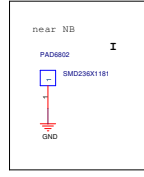
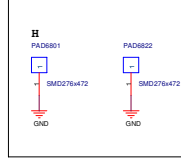
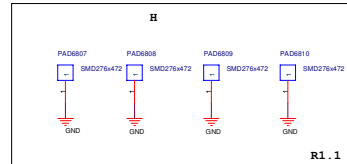
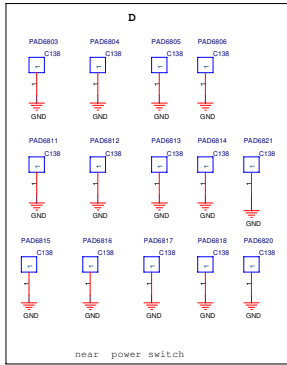
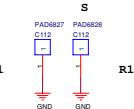
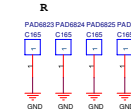
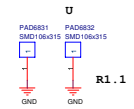
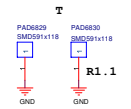
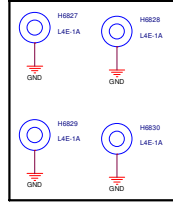
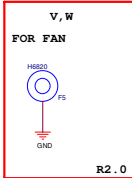
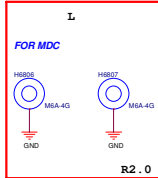
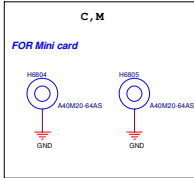
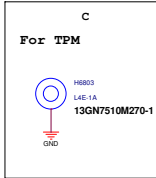
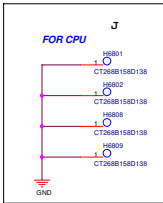

| | | | |
|------------------------|--------------|--------------------|----|
| ASUS | | Title : FSU | |
| ASUSTek Computer Inc. | | Engineer: He Wang | |
| Size | Project Name | Rev | |
| C | FSU | 1.0 | |
| Date: 2011-01-20 10:07 | Sheet: 67 | of | 68 |

FOR Thermal
R2.0





| | | | |
|---|--------------|-------------------|-----|
|  | | Title : FSU | |
| ASUSTek Computer Inc. | | Engineer: He Wang | |
| Size | Project Name | Rev | |
| C | FSU | | 1.0 |
| Date: 2011-05-26 10:07 | Sheet: 01 | of | 01 |

| | | | |
|---|--------------|-------------------|----|
|  | | Title : FSU | |
| ASUSTek Computer Inc. | | Engineer: He Wang | |
| Size | Project Name | Rev | |
| C | FSU | 1.0 | |
| Date: 2011-05-26 10:07 | Sheet: 01 | of | 01 |

| | | | |
|---|--------------|-------------------|-----|
|  | | Title : FSU | |
| ASUSTeK Computer INC. | | Engineer: He_Wang | |
| Size | Project Name | | Rev |
| C | FSU | | 1.0 |
| Date: 2011-11-28 2007 | | Sheet: 11 of 28 | |

| | | | |
|---|--------------|-------------------|-----|
|  | | Title : FSU | |
| ASUSTeK Computer INC. | | Engineer: He_Wang | |
| Size | Project Name | | Rev |
| C | FSU | | 1.0 |
| Date: 2007-11-26 2007 | | Sheet: 15 of 28 | |

| | | | |
|---|--------------|-------------------|-----|
|  | | Title : FSU | |
| ASUSTeK Computer INC. | | Engineer: He_Wang | |
| Size | Project Name | | Rev |
| C | FSU | | 1.0 |
| Date: 2011-11-28 2007 | | Sheet: 13 of 28 | |

| | | | |
|---|--------------|-------------------|-----|
|  | | Title : FSU | |
| ASUSTeK Computer INC. | | Engineer: He_Wang | |
| Size | Project Name | | Rev |
| C | FSU | | 1.0 |
| Date: 2017-11-28 20:07 | | Sheet: 14 of 28 | |

| | | | |
|---|--------------|-------------------|-----|
|  | | Title : FSU | |
| ASUSTeK Computer INC. | | Engineer: He_Wang | |
| Size | Project Name | | Rev |
| C | FSU | | 1.0 |
| Date: 2017-11-28 20:07 | | Sheet: 15 of 28 | |

| | | | |
|---|--------------|-------------------|-----|
|  | | Title : FSU | |
| ASUSTeK Computer INC. | | Engineer: He_Wang | |
| Size | Project Name | | Rev |
| C | FSU | | 1.0 |
| Date: 2017-11-28 20:07 | | Sheet: 16 of 28 | |

| | | | |
|---|--------------|-------------------|-----|
|  | | Title : FSU | |
| ASUSTeK Computer INC. | | Engineer: He_Wang | |
| Size | Project Name | | Rev |
| C | FSU | | 1.0 |
| Date: 2011-11-28 2007 | | Sheet: 11 of 28 | |

| | | | |
|---|--------------|-------------------|-----|
|  | | Title : FSU | |
| ASUSTeK Computer INC. | | Engineer: He_Wang | |
| Size | Project Name | | Rev |
| C | FSU | | 1.0 |
| Date: 2007-11-26 2007 | | Sheet: 15 of 25 | |

| | | | |
|---|--------------|-------------------|-----|
|  | | Title : FSU | |
| ASUSTek Computer Inc. | | Engineer: He Wang | |
| Size | Project Name | Rev | |
| C | FSU | | 1.0 |
| Date: 2011-03-29 10:07 | Sheet: 01 | of | 01 |

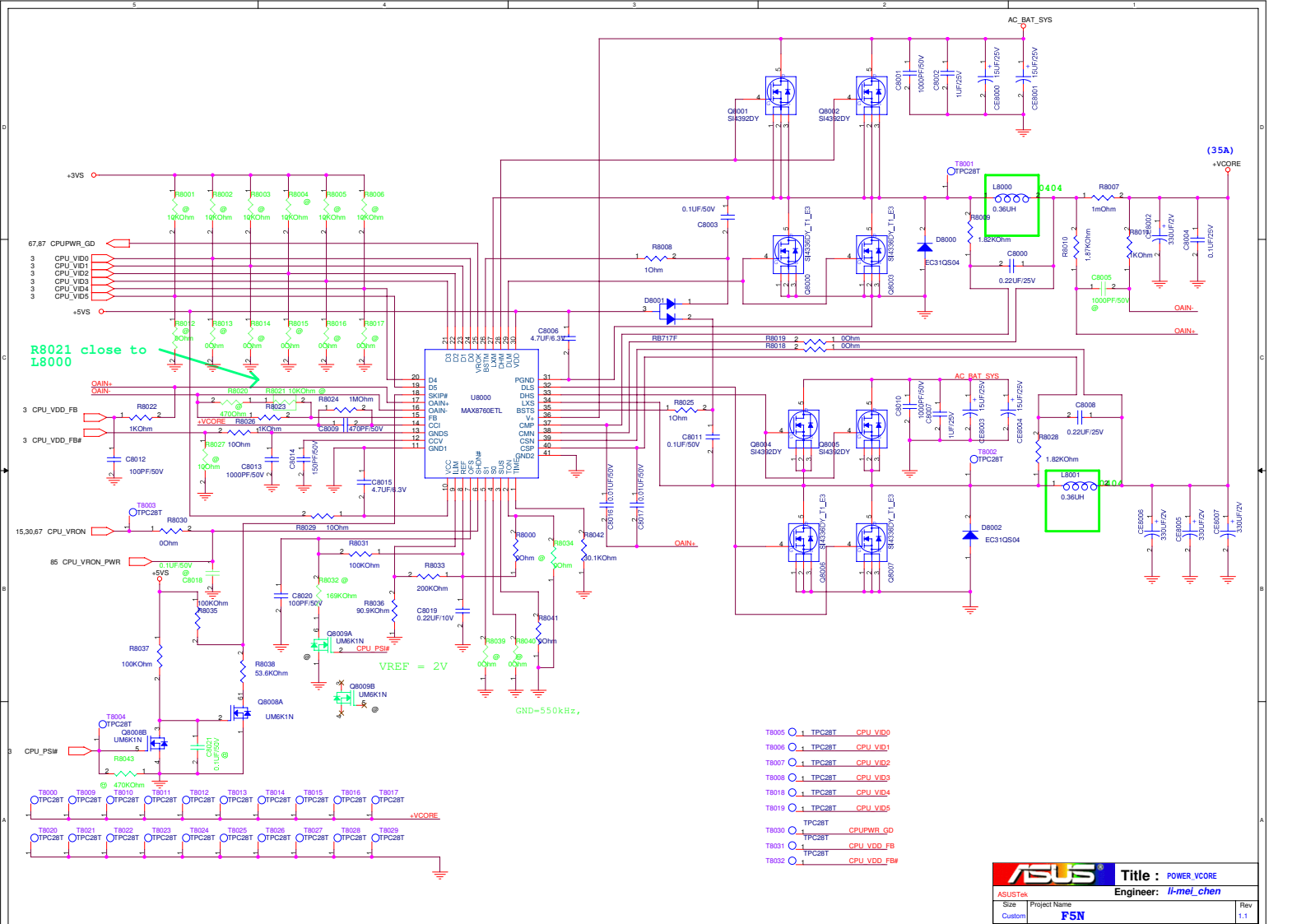

R8021 close to L8000

VREF = 2V
GND=550kHz

- T8005 1 TPC28T CPU_VD0
- T8006 1 TPC28T CPU_VD1
- T8007 1 TPC28T CPU_VD2
- T8008 1 TPC28T CPU_VD3
- T8018 1 TPC28T CPU_VD4
- T8019 1 TPC28T CPU_VD5
- T8030 1 TPC28T CPU_PWR_GD
- T8031 1 TPC28T CPU_VDD_FB
- T8032 1 TPC28T CPU_VDD_FB#

| | | | |
|------------------|--------------|----------------------------|---------|
| ASUS | | Title : POWER_VCORE | |
| ASUSTek | Project Name | Engineer: li-mei_chen | |
| Size | Custom | F5N | Rev 1.1 |
| Date: 11/09/2007 | Sheet 80 | of 88 | |

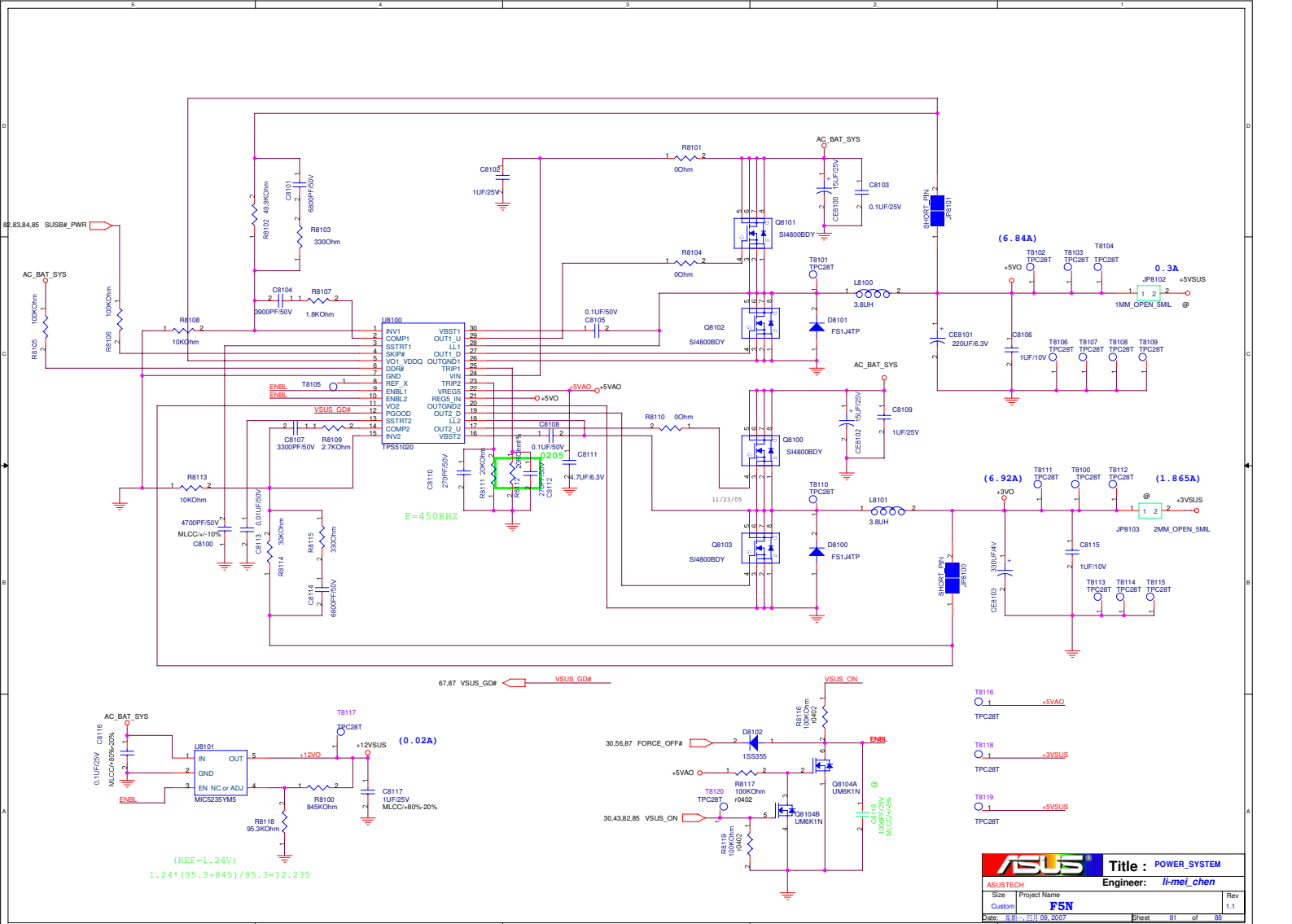

67.87 V_SUS_GD#

V_SUS_ON

- T8116 1 +5VAO
- TPC28T
- T8118 1 +3VSUS
- TPC28T
- T8119 1 +5VSUS
- TPC28T

(REF=1.24V)
 $1.24 * (95.3 + 845) / 95.3 = 12.235$

(0.02A)

| Size | Project Name | Rev |
|--------|--------------|-----------------|
| Custom | F5N | 1.1 |
| Date: | 11/09/2007 | Sheet: 81 of 88 |

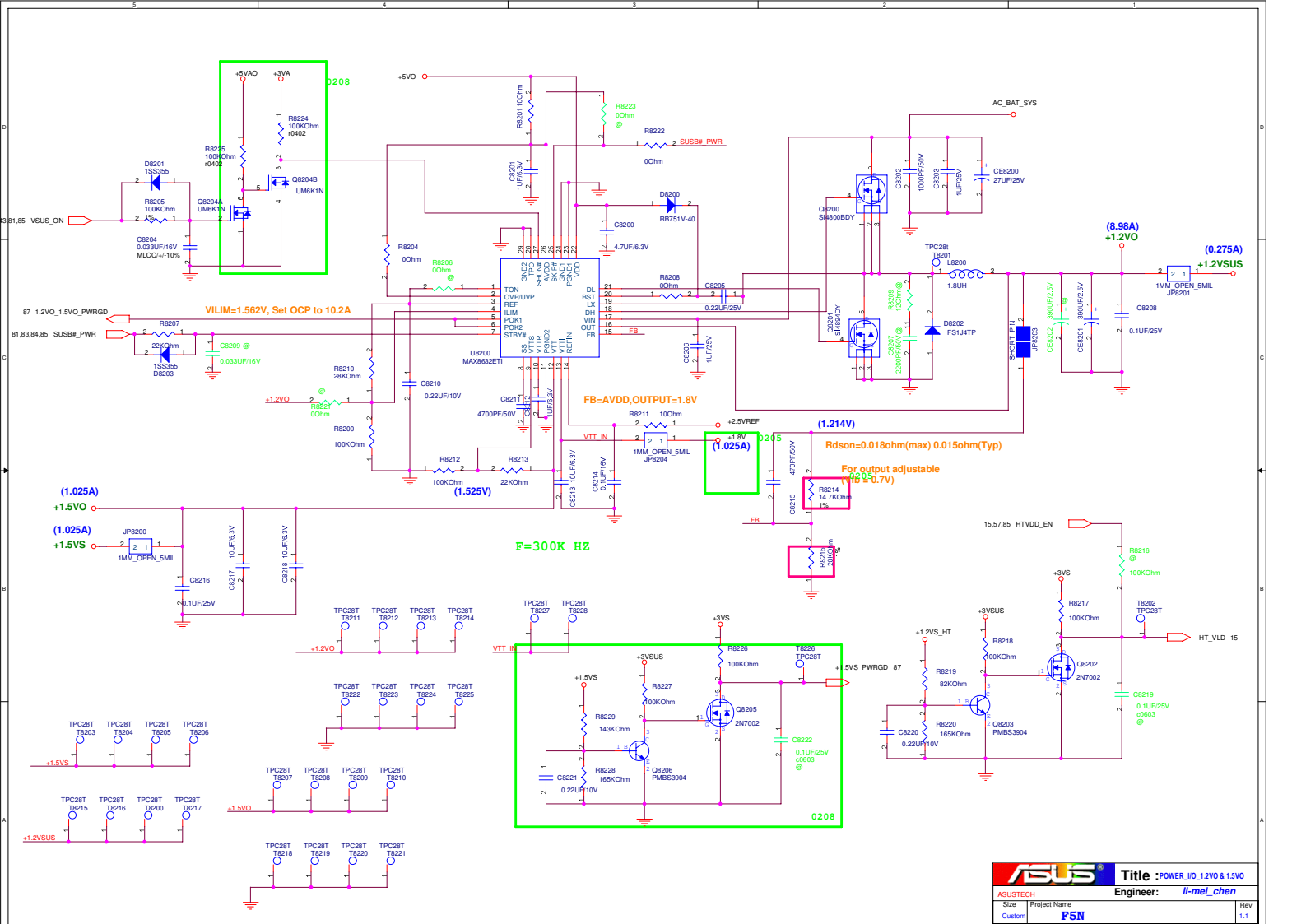

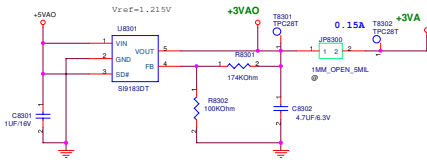

+3VA

+2.5VS

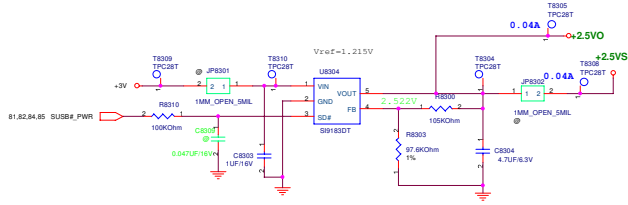

+2.5VREF

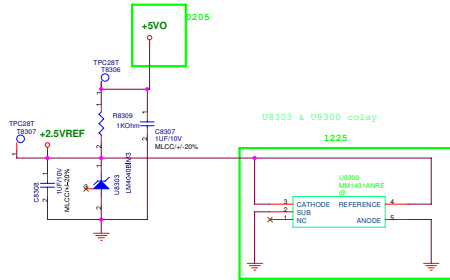

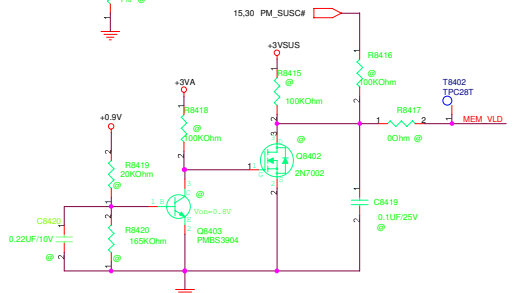
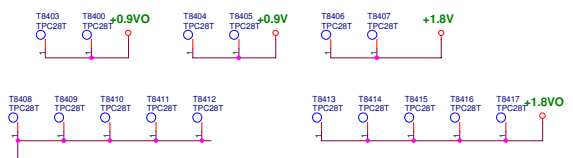
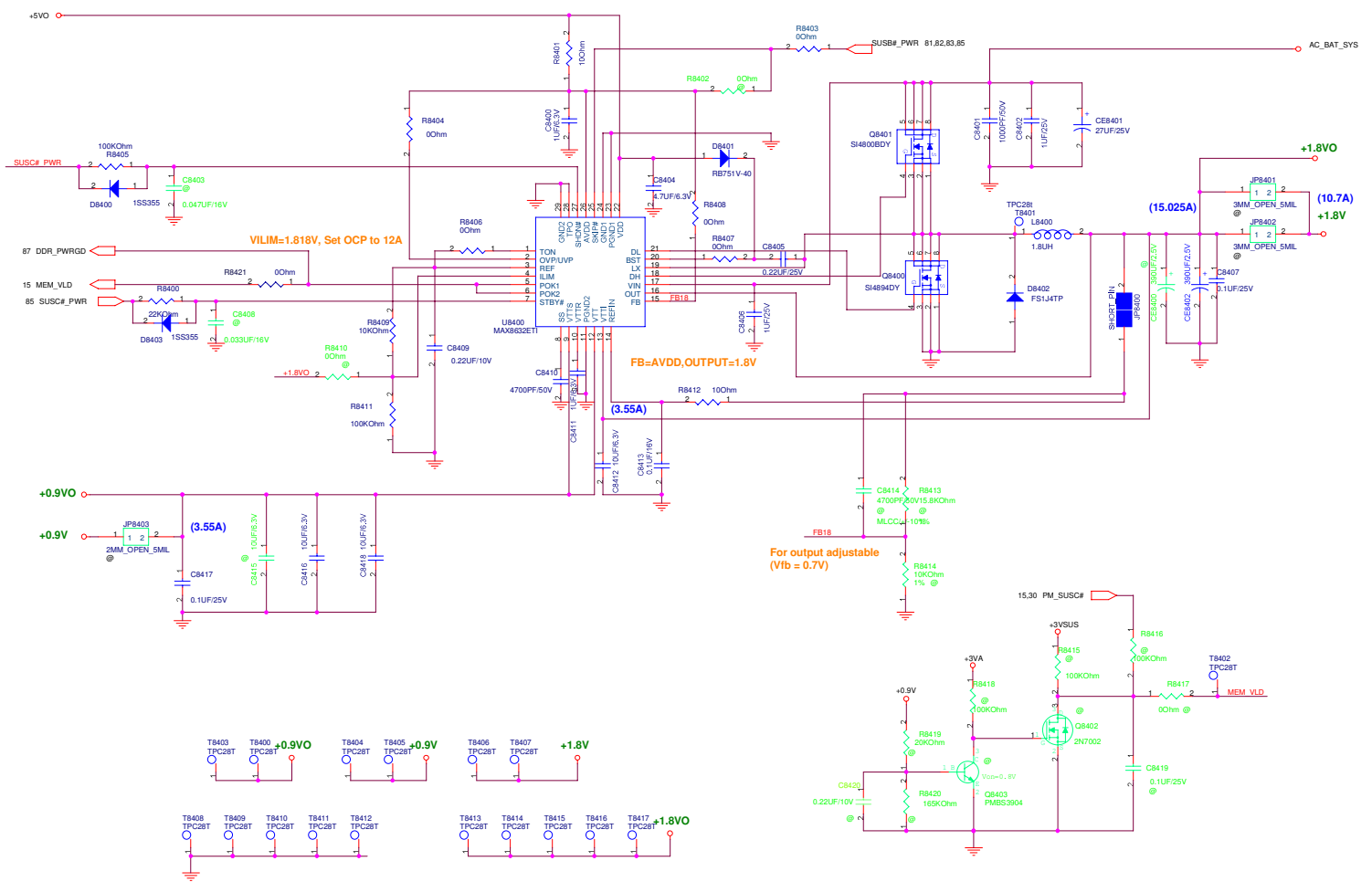

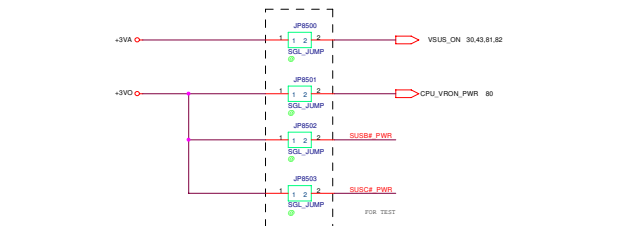
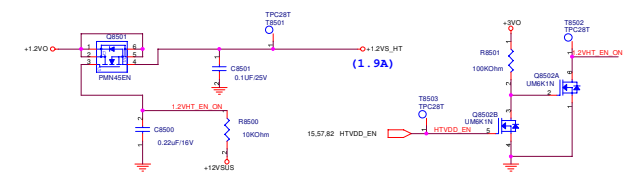
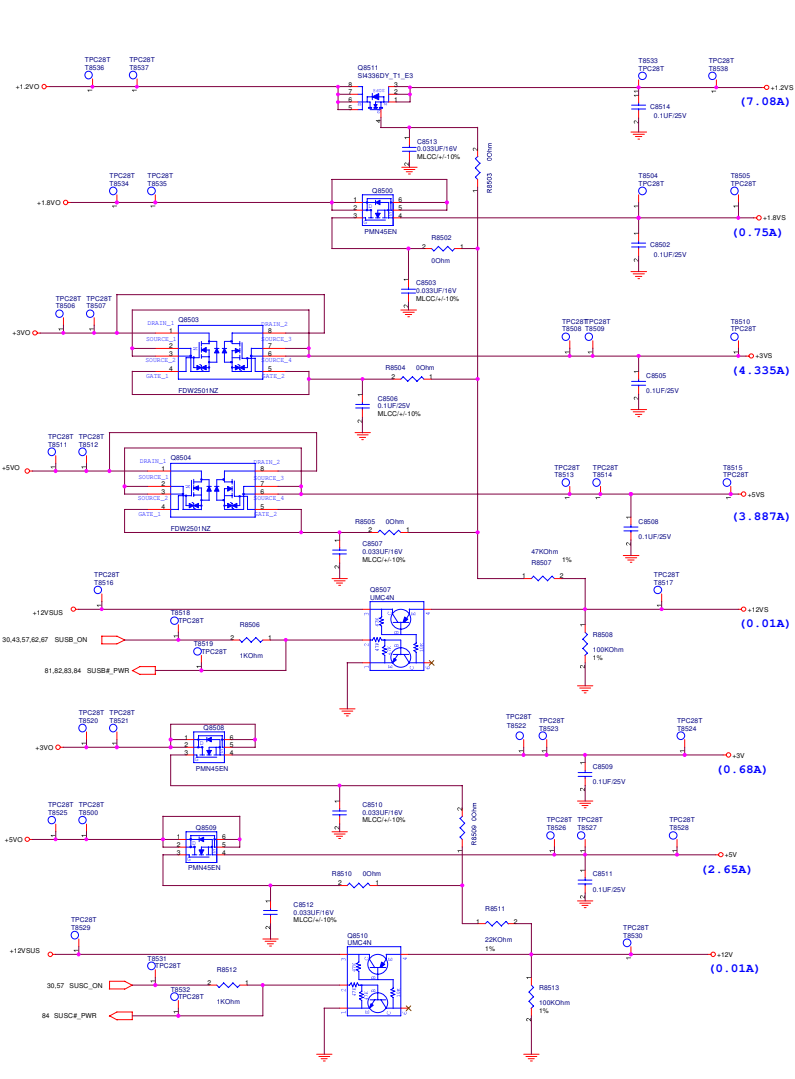

| | |
|------------|--|
| +3VA | 15.30, 46.56, 62.67, 82.83, 84 |
| +3V0 | 56.81, 82.83, 84, 86 |
| AC_BAT_SYS | 5.80, 81, 82, 84, 86 |
| AC_BAT_SYS | 5.80, 81, 82, 84, 86 |
| +VCORE | 5.80, 81, 82, 84, 86 |
| +5VAD | 81, 82, 83, 86 |
| +3V0 | 81 |
| +3V | 30.34, 43.46, 53.57, 61.62, 83 |
| +12V0US | 81 |
| +12V0_HT | 3.5, 10, 15, 57, 82 |
| +25V0 | 83 |
| +12V0USUS | 12, 16, 82 |
| +12V0S | 11, 14, 16, 57 |
| +3V5 | 3.7, 8, 10, 11, 12, 13, 14, 15, 16, 30, 36, 37, 43, 44, 45, 46, 50, 51, 53, 56, 57, 82, 87, 80, 82, 87 |
| +3V5S | 3.12, 14, 15, 16, 30, 33, 34, 43, 53, 56, 57, 87, 81, 82, 84, 87 |
| +0.9V | 5, 57, 84 |
| +12V | 37, 52, 57 |
| +12V5 | 37, 45, 46, 57 |
| +5V | 3, 7, 40, 43, 46, 52, 57 |
| +5V5 | 15, 30, 36, 37, 45, 50, 51, 56, 57, 80 |
| +2.5V5 | 3, 57, 83 |
| +1.8V0 | 84 |
| +1.8V | 3.5, 7, 8, 9, 10, 15, 57, 82, 84 |
| +1.8V5 | 12, 57 |
| BAT | 60, 86 |
| +2.5VREF | 82, 83, 86 |

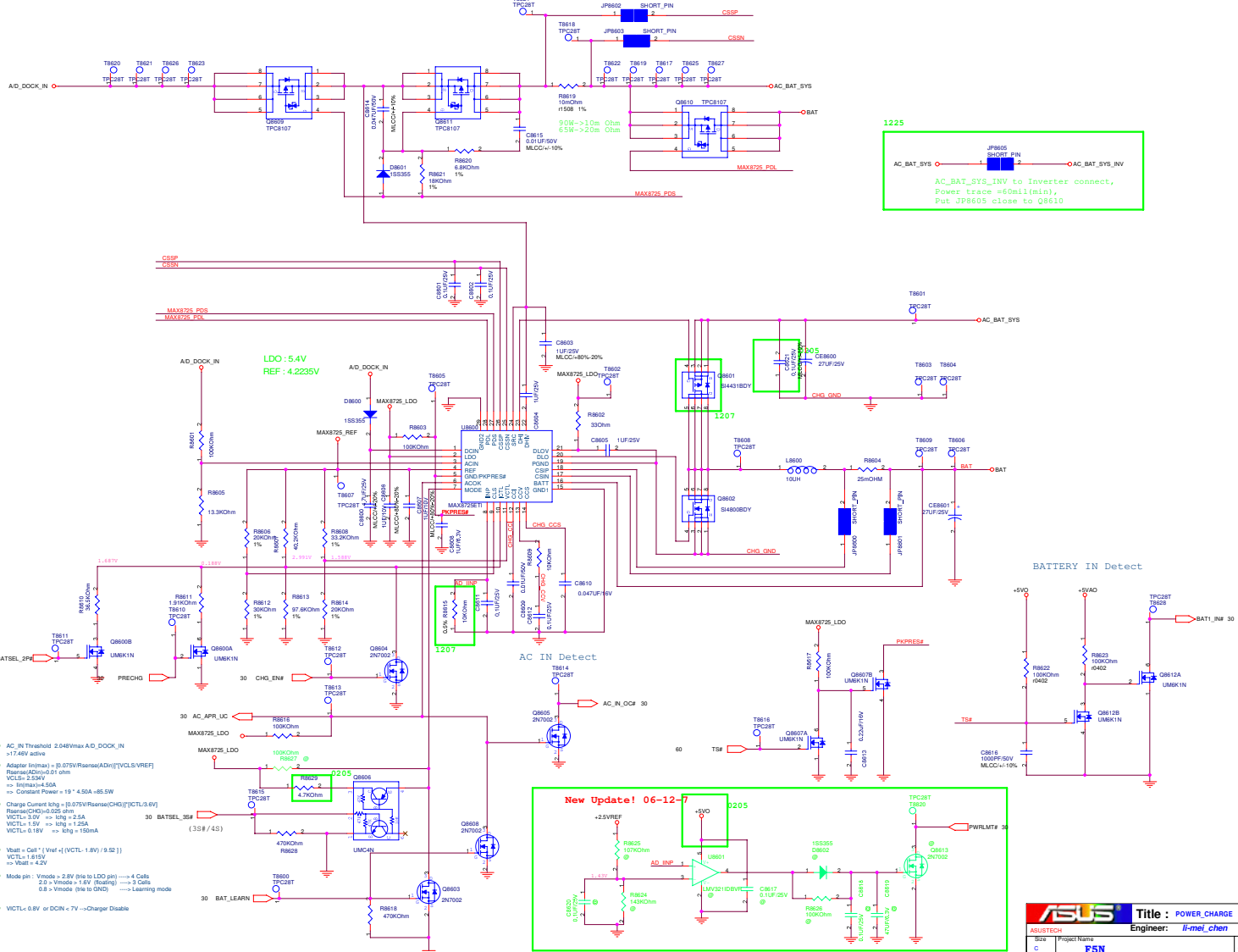

1225

AC_BAT_SYS_INV

AC_BAT_SYS_INV to Inverter connect,
Power trace =60mil(min),
Put JP8605 close to Q8610

LDO : 5.4V
REF : 4.2235V

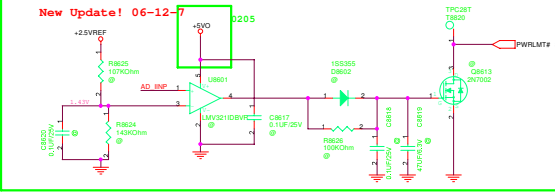

- AC_IN Threshold 2.048Vmax A/D_DOCK_IN
=> 1749V active
- Adapter In(max) = [0.075V/Rsense/A(D)]*(VCL5/VREF)
Rsense=40mΩ/0.01 ohm
VCL5 = 1.53V
=> In(max)=4.50A
- Charge Current kIq = [0.075V/Rsense/CHG]/(VCL3.8V)
Rsense=CHG=0.025 ohm
VCL3 = 3.8V => Iq = 2.5A
VCL1 = 1.5V => Iq = 1.25A
VCL1 = 0.18V => Iq = 150mA
- Vbat = Cell * [Vref / (VCL1 - Iq)] / (9.52)]
VCL1 = 1.515V
=> Vbat = 4.5V
- Mode pin : Vmode > 2.8V (High to LDO pin) => 4 Cells
2.8 > Vmode > 1.6V (Floating) => 3 Cells
0.5 > Vmode (pin to GND) => Learning mode
- VCL1 = 0.6V or DCIN < 7V --> Charger Disable

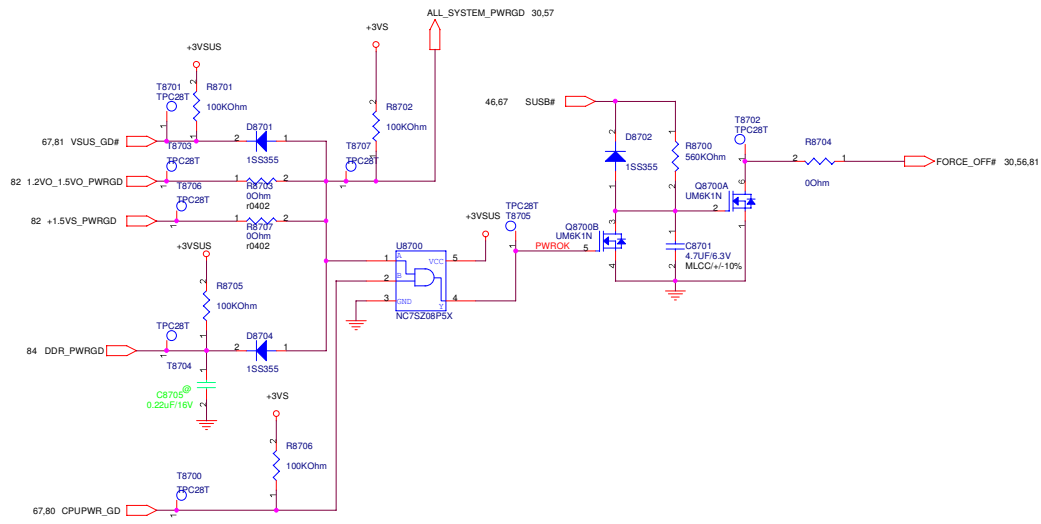

| | | | |
|------------------|--------------|------------------------------|---------|
| ASUS | | Title : POWER_PROTECT | |
| ASUSTECH | Project Name | Engineer: <i>li-mei_chen</i> | |
| Size | Custom | F5N | Rev 1.1 |
| Date: 2007-09-09 | Sheet 97 | of 88 | |

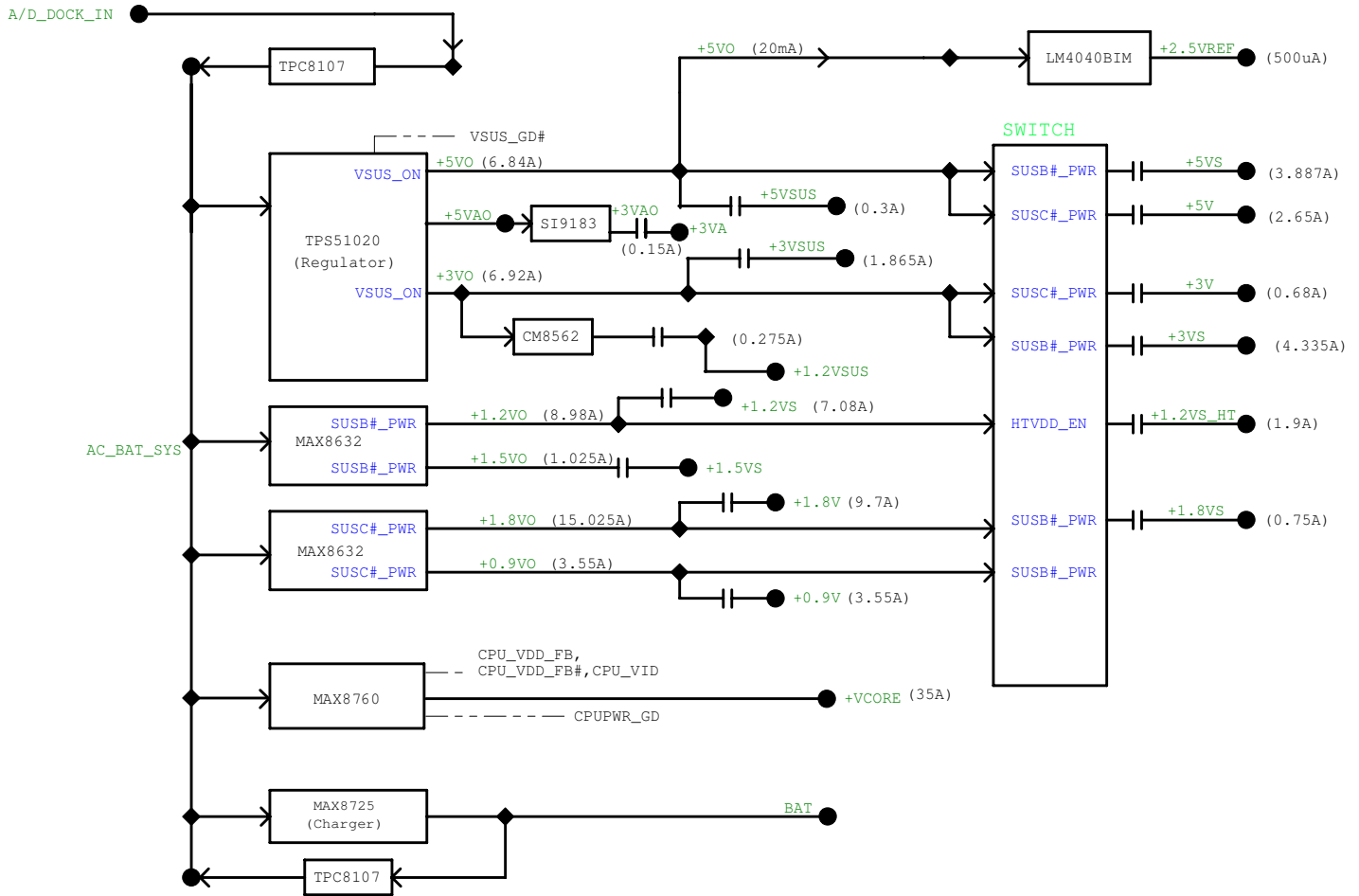

www.s-manuals.com