

M50S / X55S BLOCK DIAGRAM

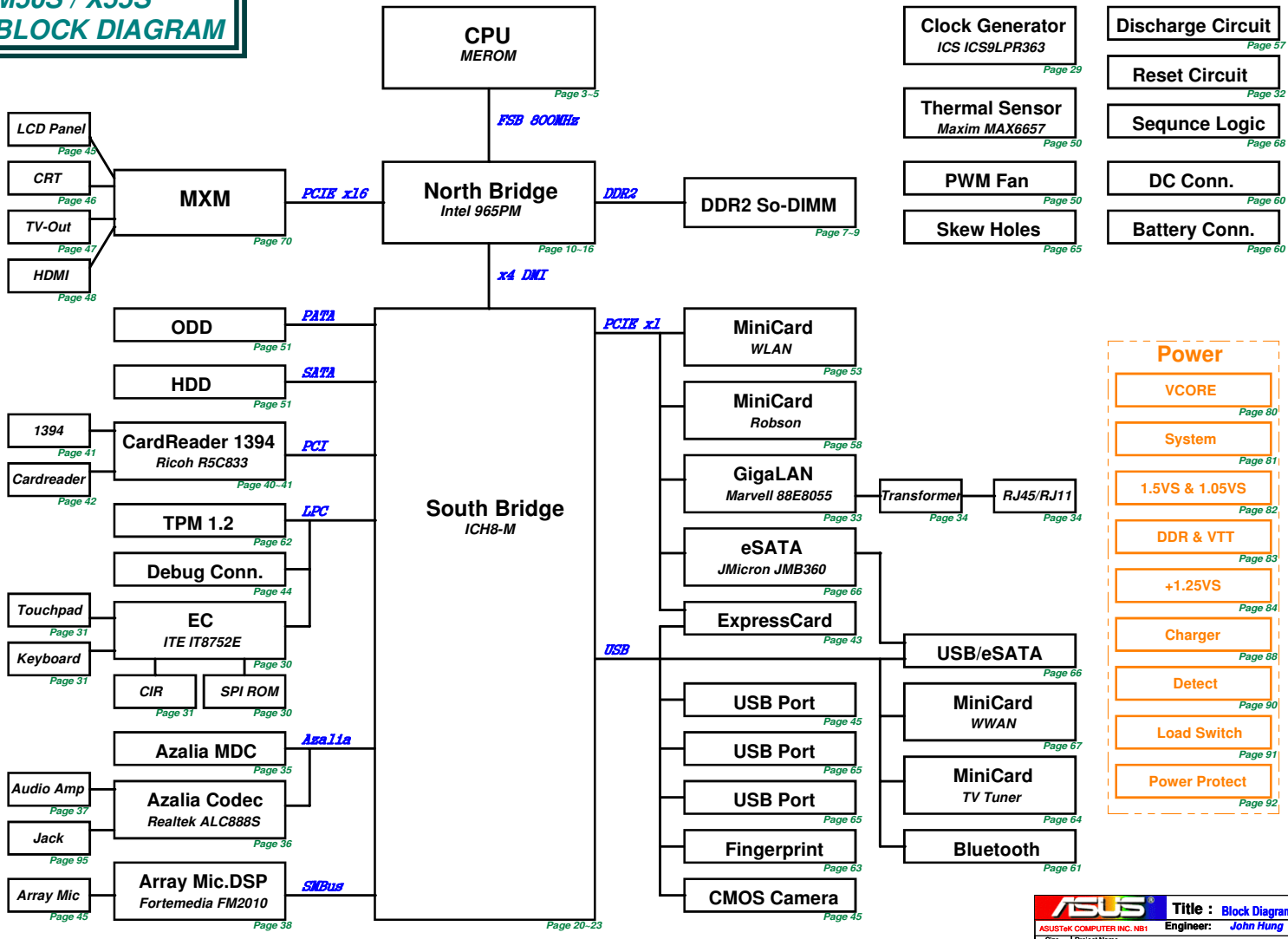

ASUS		Title : Block Diagram	
ASUSTek COMPUTER INC. NBI		Engineer: John Hung	
Size	Project Name		Rev
Custom	M50S/X55S		2.0
Date: Monday, September 03, 2007		Sheet	1 of 88

ICH8-M GPIO SETTING

Pin	Pin Name	Signal Name	Type
AG12	BM_BUSY#/GPIO0	PM_BMBUSY#	I
AJ8	TACH1/GPIO1	BT_DECT#	I
F8	PIRQE#/GPIO2	PCI_INTE#	I/OD
G11	PIROF#/GPIO3	PCI_INTF#	I/OD
F12	PIROG#/GPIO4	PCI_INTG#	I/OD
B3	PIROH#/GPIO5	PCI_INTH#	I/OD
AJ9	TACH2/GPIO6		
AH9	TACH3/GPIO7	WLAN_LED_ON	O
AE16	GPIO8	EXT_SMI#	I
AG19	WOL_EN/GPIO9		
AJ24	CLG_GPIO1/GPIO10		
AG22	SMBALERT#/GPIO11	SMB_ALERT#	I
AC19	GPIO12	EXT_SCI#	I
AH21	GLAN_DOCK#/GPIO13		
AF22	CLG_GPIO2/GPIO14		
AE20	STP_PC#/GPIO15	STP_PC#	I/O
AJ14	DPRSLVPR/GPIO16	PM_DPRSLVPR	O
AG8	TACH0/GPIO17	WLAN_ON#	O
AH12	GPIO18		
AJ10	GPIO19/SATA1GP		
AE11	GPIO20	BT_LED_ON	O
AJ12	SATA0/GPIO21		
AG10	SCLK/GPIO22		
E6	LDRQ1#/GPIO23		
AJ27	CLG_GPIO0/GPIO24		
AG18	STP_CPU#/GPIO25	STP_CPU#	O
AH27	S4_STATE#/GPIO26		
AH25	QRT_STATE0/GPIO27	BT_ON#	O
AD16	QRT_STATE1/GPIO28	CB_SD#	O
AG17	OC#5/GPIO29	INT_USB_OC#	I
AD12	OC#6/GPIO30	INT_USB_OC#	I
AJ18	OC#7/GPIO31	INT_USB_OC#	I
AH11	CLKRUN#/GPIO32	PM_CLKRUN#	O
AE10	AZ_DOCK_EN#/GPIO33		
AG14	AZ_DOCK_RST#/GPIO34		
AG13	SATACLKREQ#/GPIO35		
AF11	SATA2GP/GPIO36	EMAIL_LED#	O
AG11	SATA3GP/GPIO37	PCB_ID0	I
AF9	SLOAD/GPIO38	PCB_ID1	I
AJ11	SDATAOUT0/GPIO39	PCB_ID2	I
AG16	OC#1/GPIO40	USB_CON01_OC#	I
AG15	OC#2/GPIO41	USB_CON23_OC#	I
AE15	OC#3/GPIO42	USB_CON23_OC#	I
AF15	OC#4/GPIO43	NEWCARD_OC#	I
AD10	SATAOUT1/GPIO48		
AG29	CPUPWRGD/GPIO49	H_PWRGD	O
E18	REQ1#/GPIO50	PCI_REQ#1	I/O
C18	GNT1#/GPIO51		
B19	REQ2#/GPIO52	PCI_REQ#2	I/O
F18	GNT2#/GPIO53		
A11	REQ3#/GPIO54	PCI_REQ#3	I/O
C10	GNT3#/GPIO55		

EC IT8752E GPIO SETTING

Pin	Pin Name	Signal Name	Type
28	PWM0/GPA0	PWR_LED_UP#	O
32	PWM1/GPA1	CHG_LED_UP#	O
29	PWM2/GPA2		
33	PWM3/GPA3		
34	PWM4/GPA4	LCD_BL_PWM	O
35	PWM5/GPA5	FAN_PWM	O
36	PWM6/GPA6		
38	PWM7/GPA7		
122	RXD/GPB0	CHG_EN#	O
123	TXD/GPB1	PRECHG	O
139	CTX0/GPB2		
124	SMCLK0/GPB3	SMB0_CLK	I/O
125	SMDAT0/GPB4	SMB0_DAT	I/O
42	GA20/GPB5	A20GATE	O
4	KBRST#/GPB6	RC_IN#	O
126	GPB7	PM_RSMRST#	O
133	CRX0/GPC0	CRX0	I
129	SMCLK1/GPC1	SMB1_CLK	I/O
130	SMDAT1/GPC2	SMB1_DAT	I/O
64	GPC3	PM_PWRBTN#	O
136	WUI2/GPC4	AC_IN_OC#	I
65	GPC5	OP_SD#	O
140	WUI3/GPC6	BAT1_IN_OC#	I
20	GPC7	RFON_SW#	I
22	WUI0/GPD0	PWRLIMIT#	I
25	WUI1/GPD1	PM_SUSC#	I
26	WUI4/GPD2	BUF_PLT_RST#	I
27	ECSCI#/GPD3	EXT_SCI#	O
19	GPD4	GPC7	O
37	GPD5	LCD_BACKOFF#	O
53	TACH0 / GPD6	FANO_TACH	I
54	GPD7		
23	GPE0	VSUS_ON	O
94	GPE1	SUSC_EC#	O
95	GPE2	SUSB_EC#	O
96	GPE3	CPU_VRON	O
141	PWRSW/GPE4	PWR_SW#	I
39	WUI5/GPE5	BAT2_IN_OC#	I
21	GPE6	LID_SW#	I
24	GPE7	INSTANT_ON#	I
97	PS2LK0/GPF0		
98	PS2DAT0/GPF1	COLOREN#	I
99	PS2CLK1/GPF2	MARATHON#	I
100	PS2DAT1/GPF3	DISSTP#	I
101	PS2CLK2/GPF4	TP_CLK	I/O
102	PS2DAT2/GPF5	TP_DAT	I/O
131	SMCLK2/GPF6	THRO_CPU	O
132	SMDAT2/GPF7	TP_LED	O
118	WUI7/GPG0		
121	GPG1	PM_SUSB#	I
112	GPG2		
116	GPG6		

965GM/PM co-layout option:

965PM

Change:
U1001 to 965PM, U3601 to ALC888S
R1213-R1219 to 0ohm
C1406, C1501-C1504, C1506-C1507, C1510, C1514 to 0ohm

Mount:
D4801-D4803
F4801
J4801, J7001
H7001-H7004
Q4801
R1112-R1117, R1203-R1212, R1502, R2910, R3618-R3620, R4801-R4804
RX2901-RX2902, RX4801-RX4810
CX1201-CX1232

Un-mount:
R1202, R1401-R1403, R1501, R1503-R1505, R2909, R3621, R7001-R7008
RN7001-RN7011
RNX1201, RNX2901, RNX2915
L1501-L1505
C1404-C1405, C1407-C1409, C1505, C1509, C1511-C1513
CE1404, CE1501-CE1503

965GM

Change:
U1001 to 965GM
R1213-R1218 to 150ohm
R1219 to 1.3Kohm

Un-mount:
D4801-D4803
F4801
J4801, J7001
H7001-H7004
G4801
R1112-R1117, R1203-R1212, R1502, R2910, R3618-R3620, R4801-R4804
RX2901-RX2902, RX4801-RX4810
CX1201-CX1232

Mount:
R1202, R1401-R1403, R1501, R1503-R1505, R2909, R3621, R7001-R7008
RN7001-RN7011
RNX1201, RNX2901, RNX2915
L1501-L1505
C1404-C1409, C1501-C1507, C1509-C1514
CE1404, CE1501-CE1503

		Title : System Setting	
ASUSTek COMPUTER INC. NBI		Engineer: John Hung	
Site	Project Name	Rev	
Custom	M50S/X55S	2.0	
Date: Monday, September 03, 2007		Sheet 2 of 55	

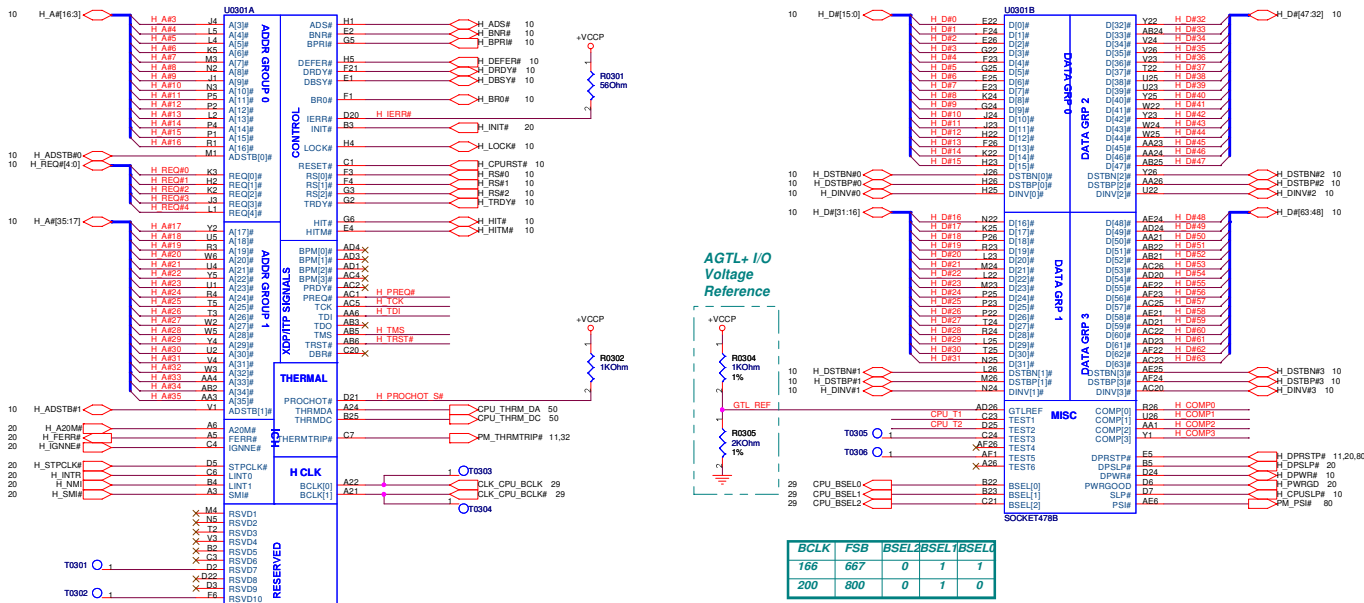

BCLK	FSB	BSEL2	BSEL1	BSEL0
166	667	0	1	1
200	800	0	1	0

Default Strapping When XDP/ITP Not Used

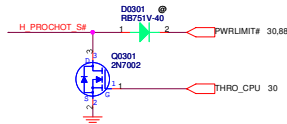
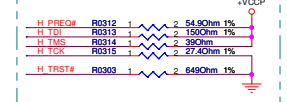

CPU Test Pin

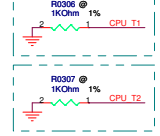

AGTL+ I/O Buffer Compensation

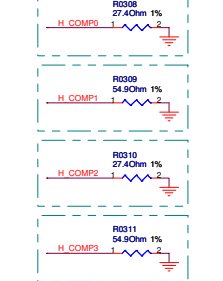

ASUS Title : CPU_Merom(Host)
ASUSTeK COMPUTER INC. NBI Engineer: John Hung
 Size: Project Name: M50S/X55S Rev: 2.0
 Date: Monday, September 03, 2007 Sheet: 3 of 88

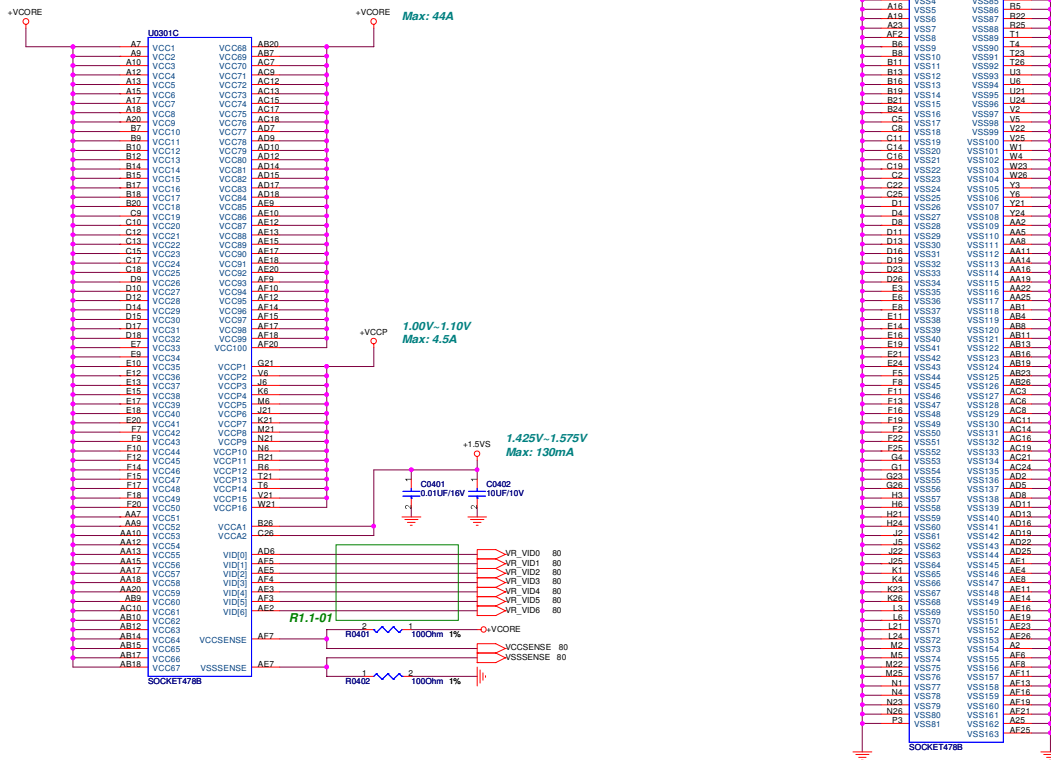

ASUS Title : CPU_Merom(PWR)
 ASUSTek COMPUTER INC. NBI Engineer: John Hung
 Sub Project Name
 Custom M50S/X55S
 Date: Monday, September 03, 2007 Sheet 4 of 55

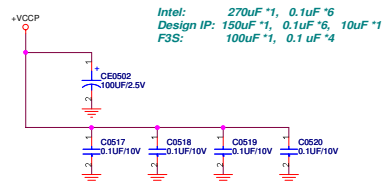
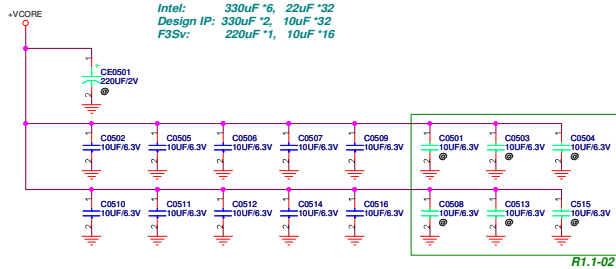

		Title : CPU_Capacitors	
ASUSTeK COMPUTER INC. NBI		Engineer: John Hung	
Site	Project Name		Rev
Custom	M50S/X55S		2.0
Date: Monday, September 03, 2007		Sheet	5 of 88

Reserved for 3G

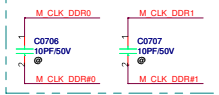

Reverse Type
H = 9.2 mm

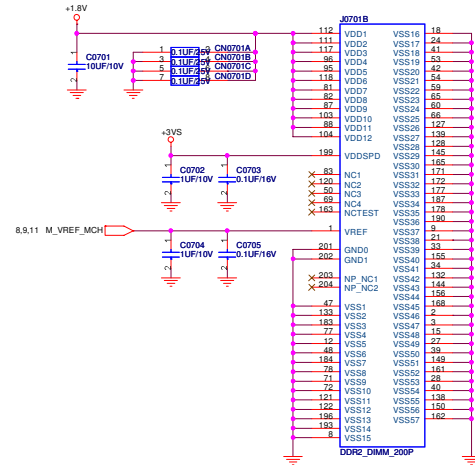
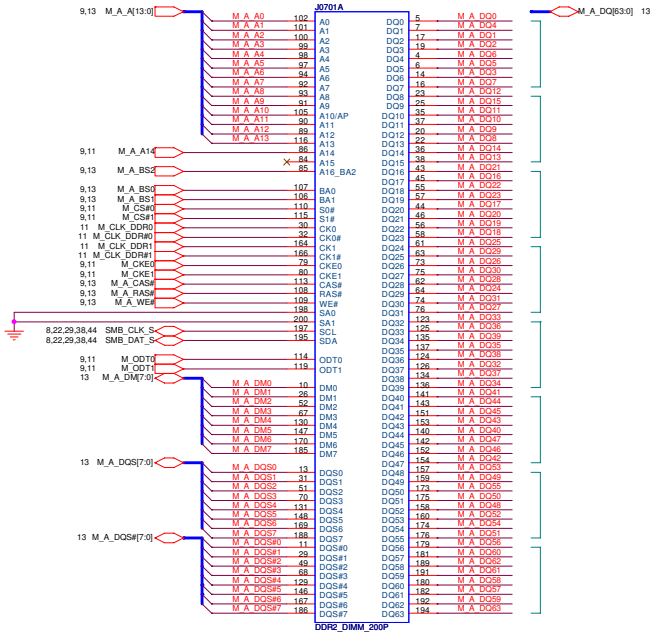

Reserved for 3G

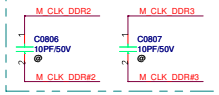

Reverse Type

H = 4.0 mm

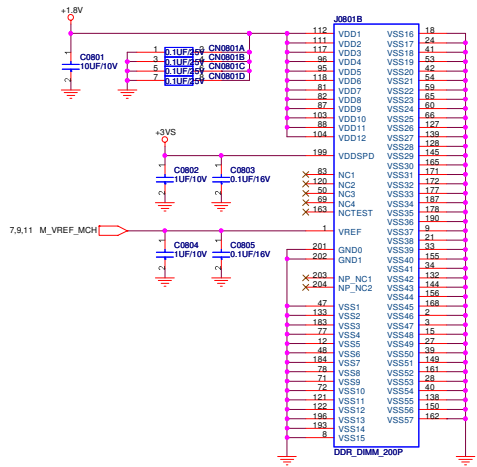
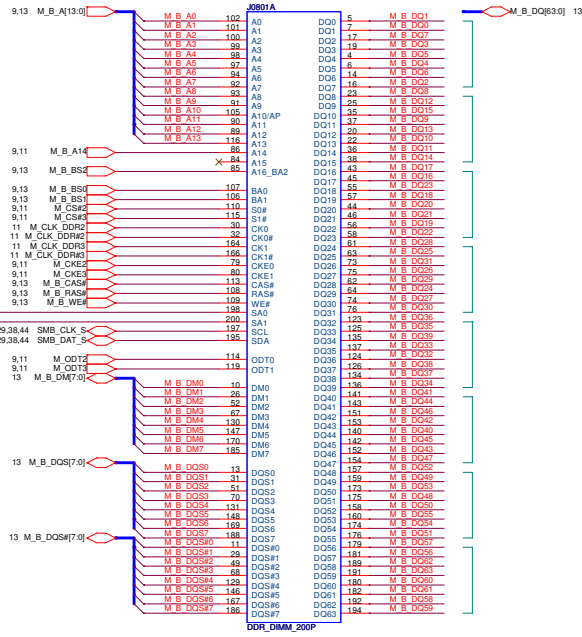

ASUS Title : DIM So-DIMM 1
 ASUSTEK COMPUTER INC. (NBI) Engineer: John Hung
 Project Name: M50S/X55S Rev: 2.0
 Date: Monday, September 03, 2007 Sheet: 8 of 88

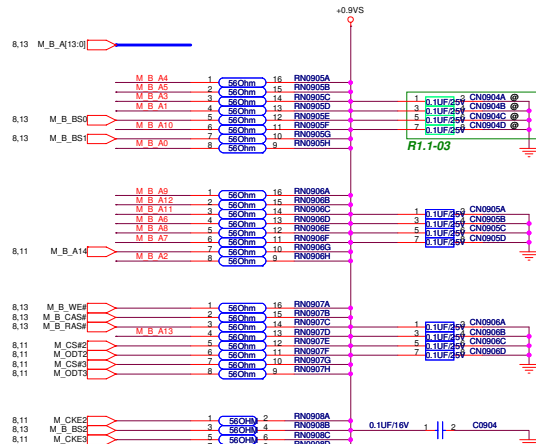
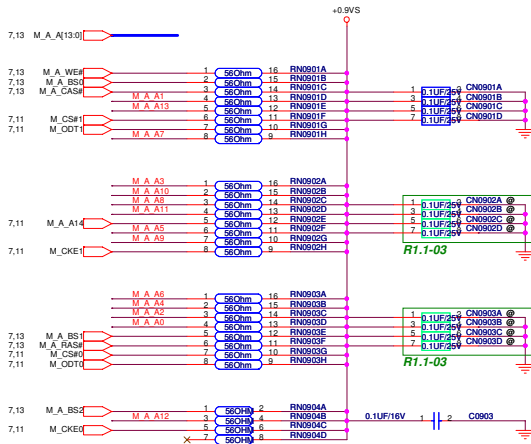
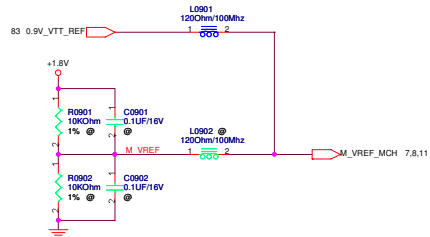

ASUS Title : DIM_DDR2 Termination
 ASUSTek COMPUTER INC. NBI Engineer: John Hung
 Project Name: M50S/X55S
 Date: Monday, September 03, 2007 Sheet 9 of 88

- CFG5 : DMI Strap**
 0 = DMI x2
 1 = DMI x4 (D)
- CFG7 : CPU Strap**
 0 = Reserved
 1 = Mobile CPU (D)
- CFG9 : PCIe Graphic Lane**
 0 = Reverse Lane
 1 = Normal Operation (D)
- CFG13:12 : GMCH Test Mode**
 00 = Partial CLK Gating Disable
 01 = XOR Mode Enable
 10 = All Z Mode Enable
 11 = Normal Operation (D)
- CFG16 : FSB Dynamic ODT**
 0 = Dynamic ODT Disable
 1 = Dynamic ODT Enable (D)
- CFG18 : Core Voltage**
 0 = 1.05V (D)
 1 = 1.5V
- CFG19 : DMI Lane Reversal**
 0 = Normal Operation (D)
 1 = Lanes Reversed
- CFG20 : Concurrent SDVO / PCIe**
 0 = Only one is operational (D)
 1 = operate simultaneous

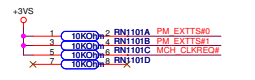
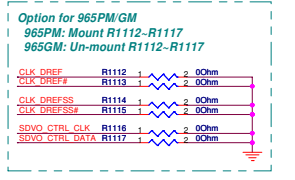
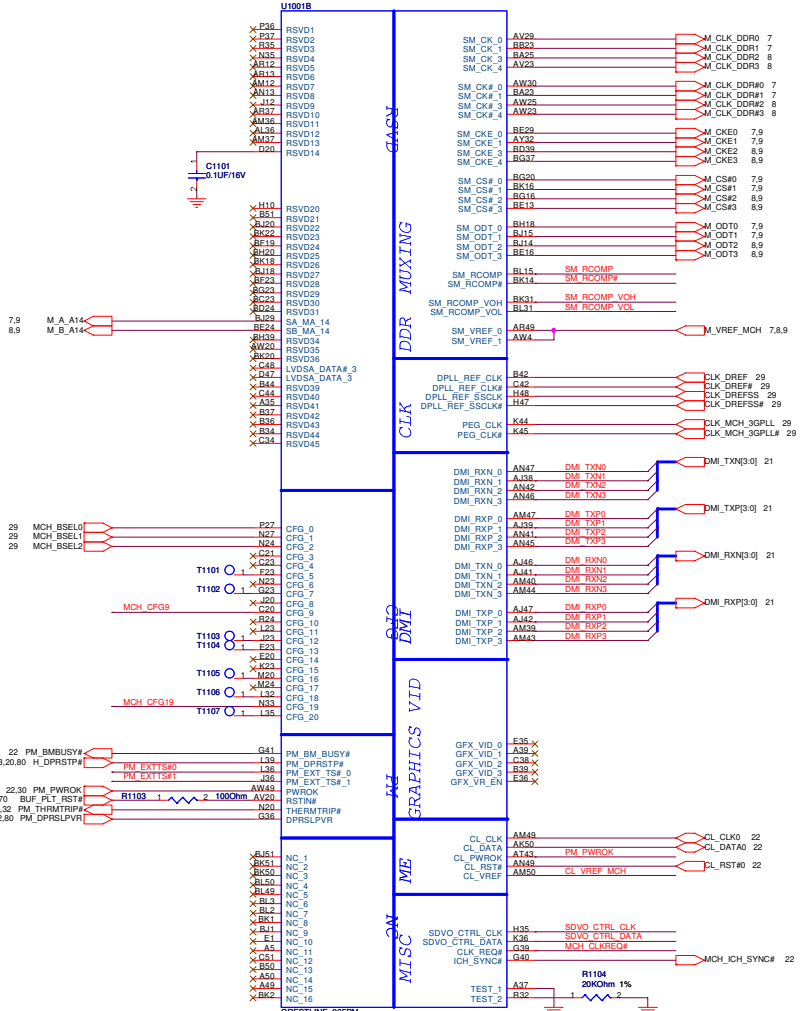

ASUS Title : NB_965PM(DM/CFG)

ASUSTek COMPUTER INC. NBI Engineer: John Hung

Size Project Name M50S/X55S Rev 2.0

Date: Monday, September 03, 2007 Sheet 11 of 85

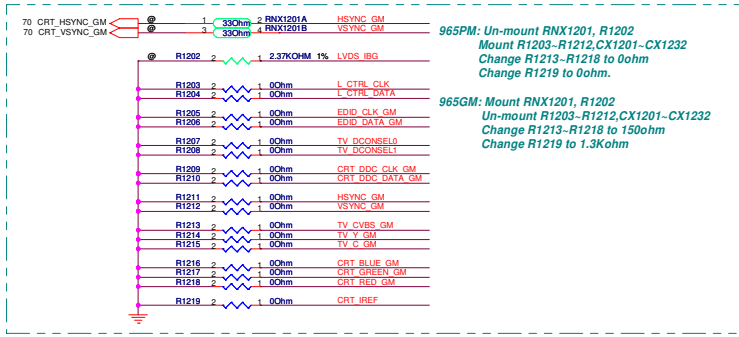
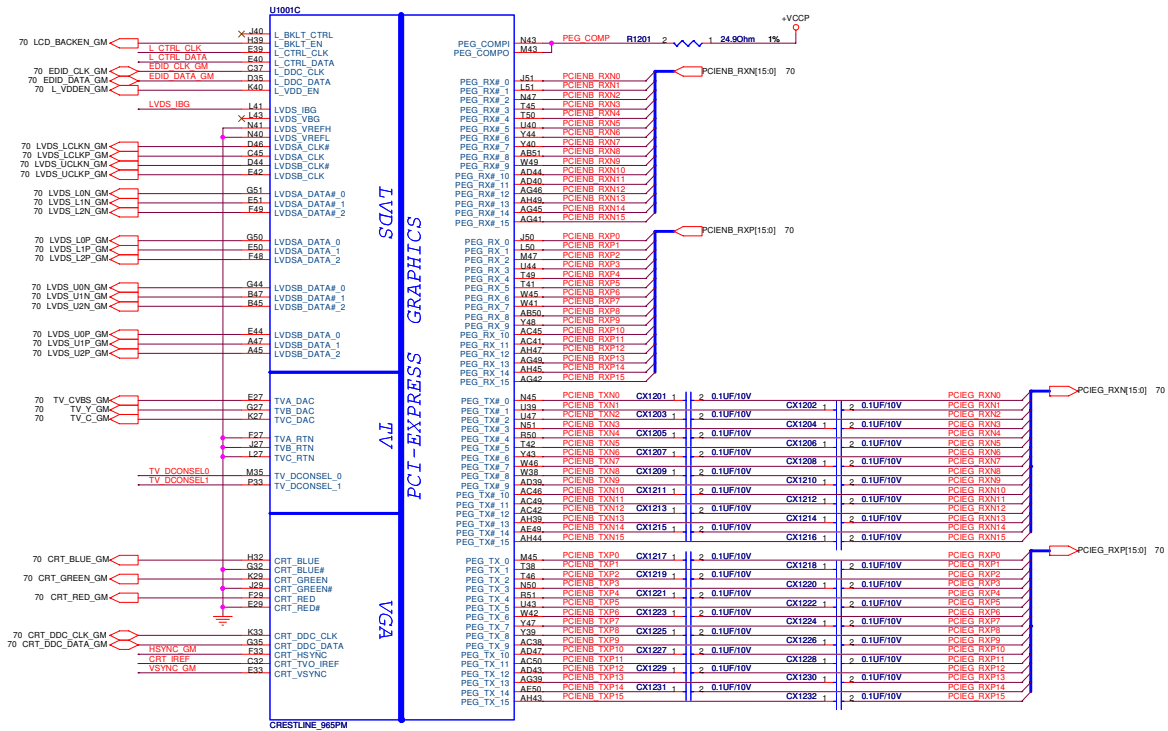

ASUS Title : NB_965PM(GFX)
 ASUSTek COMPUTER INC. NBI Engineer: John Hung
 Size Project Name
 Custom M50S/X55S Rev 2.0
 Date: Monday, September 03, 2007 Sheet 12 of 88

7 M_A_DQ[63:0]

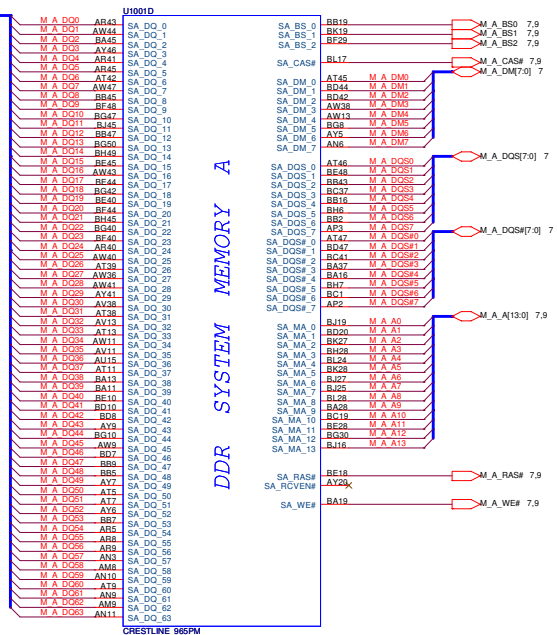

8 M_B_DQ[63:0]

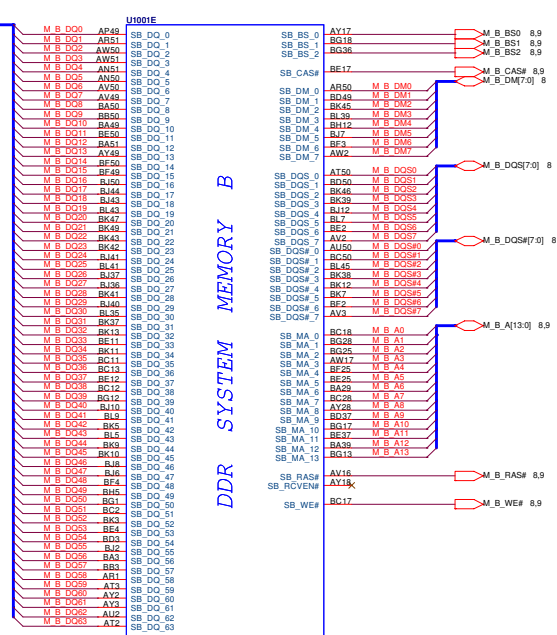

ASUS Title : NB_965PM(DDR2)
 ASUSTEK COMPUTER INC. NBI Engineer: John Hung
 Sub Project Name
 Custom M50S/X55S
 Date: Monday, September 03, 2007 Sheet 13 of 35

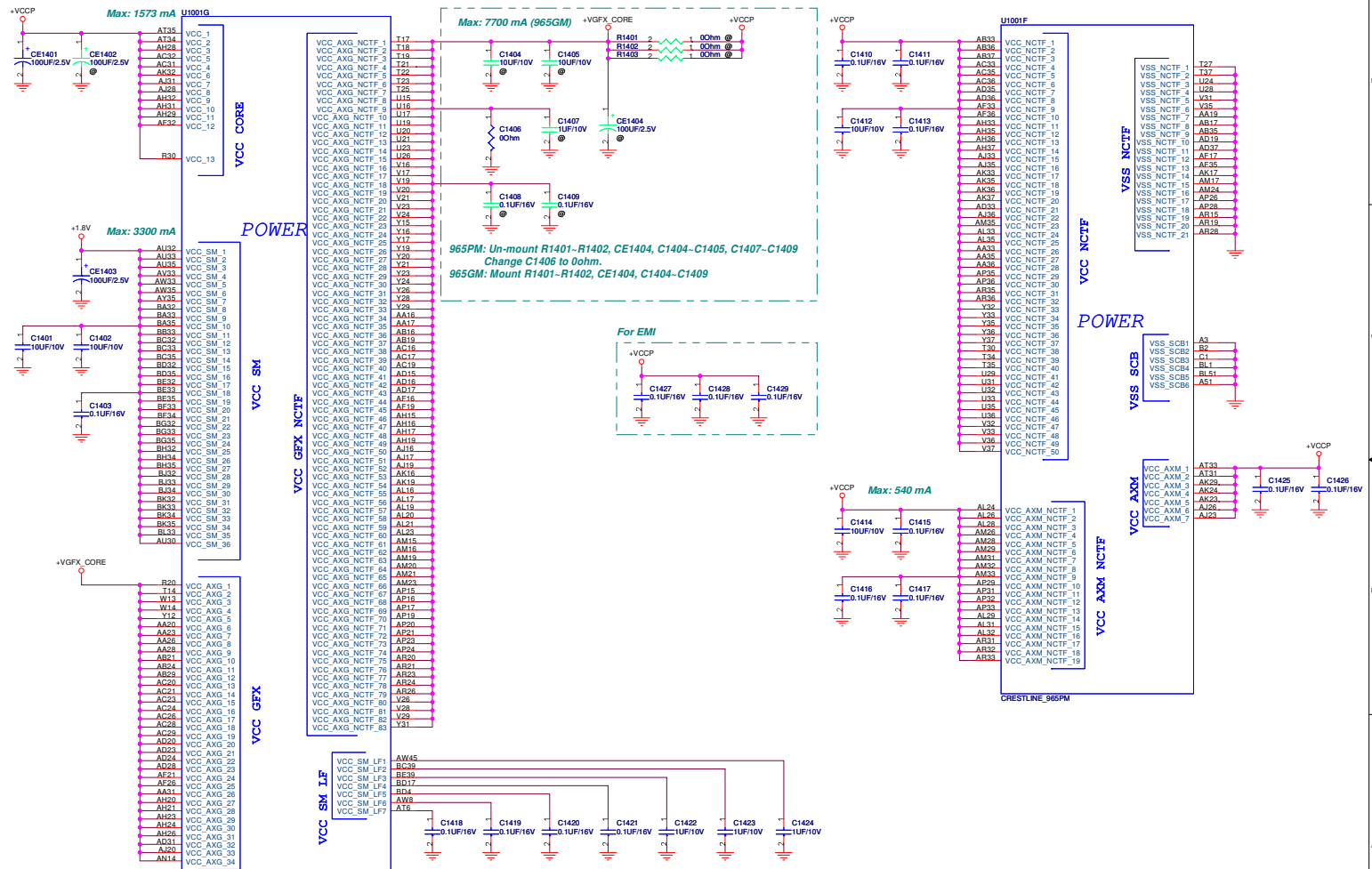

ASUS		Title : NB_965PM(PWR)
ASUSTek COMPUTER INC. NB1	Project Name	Engineer: John Hung
Custom	Project Name	M50S/X55S
Date: Tuesday, September 04, 2007	Sheet	14 of 85

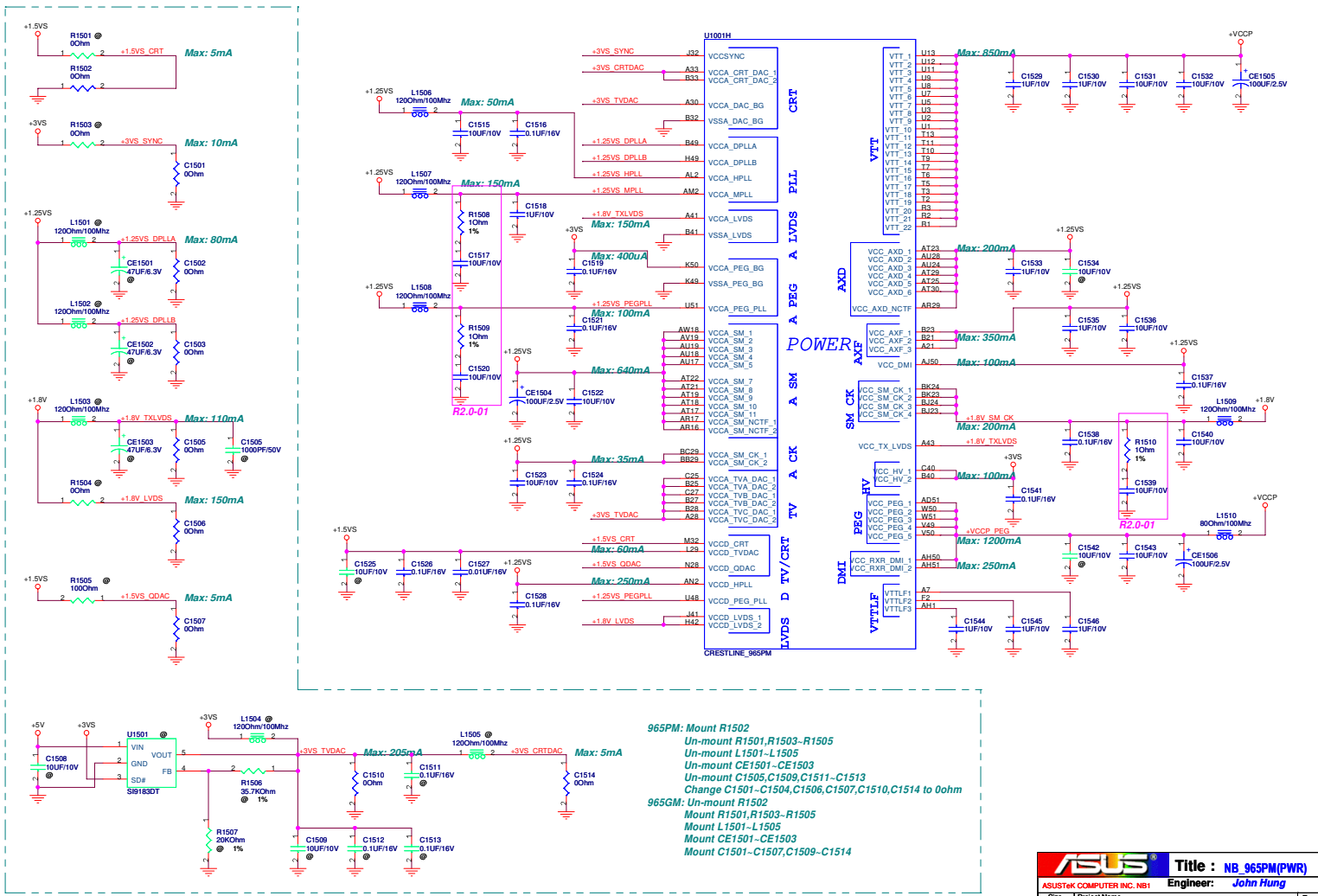

U1001J		AW24	
A13	VSS_1	VSS_100	AW24
A15	VSS_2	VSS_101	AW25
A17	VSS_3	VSS_102	AW26
A21	VSS_4	VSS_103	AW5
AA24	VSS_5	VSS_104	AW7
AA24	VSS_6	VSS_105	AV10
AB21	VSS_7	VSS_106	AV37
AB21	VSS_8	VSS_107	AV42
AB21	VSS_9	VSS_108	AV43
AB21	VSS_10	VSS_109	AV44
AB21	VSS_11	VSS_110	AV45
AB21	VSS_12	VSS_111	AV47
AC10	VSS_13	VSS_112	AV50
AC10	VSS_14	VSS_113	BL10
AC3	VSS_15	VSS_114	BL20
AC38	VSS_16	VSS_115	BL24
AD1	VSS_17	VSS_116	BL30
AD1	VSS_18	VSS_117	BL31
AD21	VSS_19	VSS_118	BL38
AD21	VSS_20	VSS_119	BL42
AD21	VSS_21	VSS_120	BL43
AD41	VSS_22	VSS_121	BL46
AD41	VSS_23	VSS_122	BL5
AD45	VSS_24	VSS_123	BL8
AD45	VSS_25	VSS_124	BL11
AD45	VSS_26	VSS_125	BL12
AD45	VSS_27	VSS_126	BL15
AD50	VSS_28	VSS_127	BL22
AD50	VSS_29	VSS_128	BL24
AD50	VSS_30	VSS_129	BL25
AE5	VSS_31	VSS_130	BL40
AE5	VSS_32	VSS_131	BL44
AF20	VSS_33	VSS_132	BL45
AF24	VSS_34	VSS_133	BL46
AF24	VSS_35	VSS_134	BL8
AF31	VSS_36	VSS_135	BL13
AG2	VSS_37	VSS_136	BL24
AG38	VSS_38	VSS_137	BL25
AG41	VSS_39	VSS_138	BL29
AG47	VSS_40	VSS_139	BL40
AG50	VSS_41	VSS_140	BL43
AH3	VSS_42	VSS_141	BL46
AH40	VSS_43	VSS_142	BL46
AH41	VSS_44	VSS_143	BL46
AH4	VSS_45	VSS_144	BL46
AH5	VSS_46	VSS_145	BL5
AH11	VSS_47	VSS_146	BL19
AH11	VSS_48	VSS_147	BL25
AH11	VSS_49	VSS_148	BL29
AH2	VSS_50	VSS_149	BL42
AH2	VSS_51	VSS_150	BL42
AH2	VSS_52	VSS_151	BL42
AH3	VSS_53	VSS_152	BL8
AH3	VSS_54	VSS_153	BL12
AH3	VSS_55	VSS_154	BL16
AK21	VSS_56	VSS_155	BL36
AK28	VSS_57	VSS_156	BL36
AK28	VSS_58	VSS_157	BL32
AK31	VSS_59	VSS_158	BL36
AK31	VSS_60	VSS_159	BL29
AK31	VSS_61	VSS_160	BL29
AL1	VSS_62	VSS_161	BL39
AM1	VSS_63	VSS_162	BL46
AM13	VSS_64	VSS_163	BL5
AM3	VSS_65	VSS_164	BL5
AM4	VSS_66	VSS_165	BL17
AM41	VSS_67	VSS_166	BL30
AM45	VSS_68	VSS_167	BL44
AN1	VSS_69	VSS_168	BL46
AN38	VSS_70	VSS_169	BL11
AN38	VSS_71	VSS_170	BL13
AN38	VSS_72	VSS_171	BL38
AN3	VSS_73	VSS_172	BL38
AN3	VSS_74	VSS_173	BL4
AP4	VSS_75	VSS_174	BL42
AP48	VSS_76	VSS_175	BL46
AP50	VSS_77	VSS_176	BL15
AR1	VSS_78	VSS_177	BL17
AR2	VSS_79	VSS_178	BL25
AR28	VSS_80	VSS_179	BL30
AR44	VSS_81	VSS_180	BL36
AR47	VSS_82	VSS_181	BL40
AR7	VSS_83	VSS_182	BL44
AT10	VSS_84	VSS_183	BL6
AT14	VSS_85	VSS_184	BL6
AT41	VSS_86	VSS_185	BL11
AT48	VSS_87	VSS_186	BL13
AU1	VSS_88	VSS_187	BL19
AU21	VSS_89	VSS_188	BL22
AU28	VSS_90	VSS_189	BL37
AU2	VSS_91	VSS_190	BL47
AU32	VSS_92	VSS_191	CL12
AU49	VSS_93	VSS_192	CL16
AU51	VSS_94	VSS_193	CL28
AV38	VSS_95	VSS_194	CL28
AV48	VSS_96	VSS_195	CL28
AW1	VSS_97	VSS_196	CL30
AW12	VSS_98	VSS_197	CL36
AW18	VSS_99	VSS_198	CL41

VSS

CRESTLINE_965PM

U1001J		W11	
C4	VSS_199	VSS_287	W39
C20	VSS_200	VSS_288	W39
C7	VSS_201	VSS_289	W43
D14	VSS_202	VSS_290	W47
D24	VSS_203	VSS_291	W5
D3	VSS_204	VSS_292	W7
D32	VSS_205	VSS_293	Y13
D38	VSS_206	VSS_294	Y2
D46	VSS_207	VSS_295	Y2
D48	VSS_208	VSS_296	Y41
E10	VSS_209	VSS_297	Y45
E16	VSS_210	VSS_298	Y49
E24	VSS_211	VSS_299	Y5
E28	VSS_212	VSS_300	Y50
E47	VSS_213	VSS_301	Y11
E50	VSS_214	VSS_302	Y28
F19	VSS_215	VSS_303	Y28
F4	VSS_216	VSS_304	T31
F49	VSS_217	VSS_305	T53
F50	VSS_218	VSS_306	R28
G13	VSS_219	VSS_307	AA32
G1	VSS_220	VSS_308	AB32
G16	VSS_221	VSS_309	AC32
G18	VSS_222	VSS_310	AF28
G24	VSS_223	VSS_311	AF29
G28	VSS_224	VSS_312	AV25
G32	VSS_225	VSS_313	HS0
G38	VSS_226		
G33	VSS_227		
G42	VSS_228		
G45	VSS_229		
G48	VSS_230		
G8	VSS_231		
H24	VSS_232		
H38	VSS_233		
H4	VSS_234		
H45	VSS_235		
J11	VSS_236		
J16	VSS_237		
J2	VSS_238		
J24	VSS_239		
J28	VSS_240		
J33	VSS_241		
J35	VSS_242		
J39	VSS_243		
K12	VSS_245		
K47	VSS_246		
L1	VSS_247		
L11	VSS_248		
L17	VSS_249		
L20	VSS_250		
L24	VSS_251		
L28	VSS_252		
L3	VSS_253		
L48	VSS_254		
L49	VSS_255		
M28	VSS_256		
M42	VSS_257		
M46	VSS_258		
M49	VSS_259		
M5	VSS_260		
M50	VSS_261		
M9	VSS_262		
N11	VSS_263		
N14	VSS_264		
N17	VSS_265		
N29	VSS_266		
N30	VSS_267		
N36	VSS_268		
N39	VSS_269		
N44	VSS_270		
N49	VSS_271		
N7	VSS_272		
P19	VSS_273		
P2	VSS_274		
P23	VSS_275		
P3	VSS_276		
P50	VSS_277		
P49	VSS_278		
T30	VSS_279		
T43	VSS_280		
T47	VSS_281		
U41	VSS_282		
U45	VSS_283		
U50	VSS_284		
V2	VSS_285		
V3	VSS_286		

VSS

CRESTLINE_965PM

ASUS		Title : NB_965PM(GND)	
ASUSTEK COMPUTER INC. NBI		Engineer: John Hung	
Size	Project Name	Rev	
Custom	M50S/X55S	2.0	
Date: Monday, September 03, 2007	Sheet	16	of 85

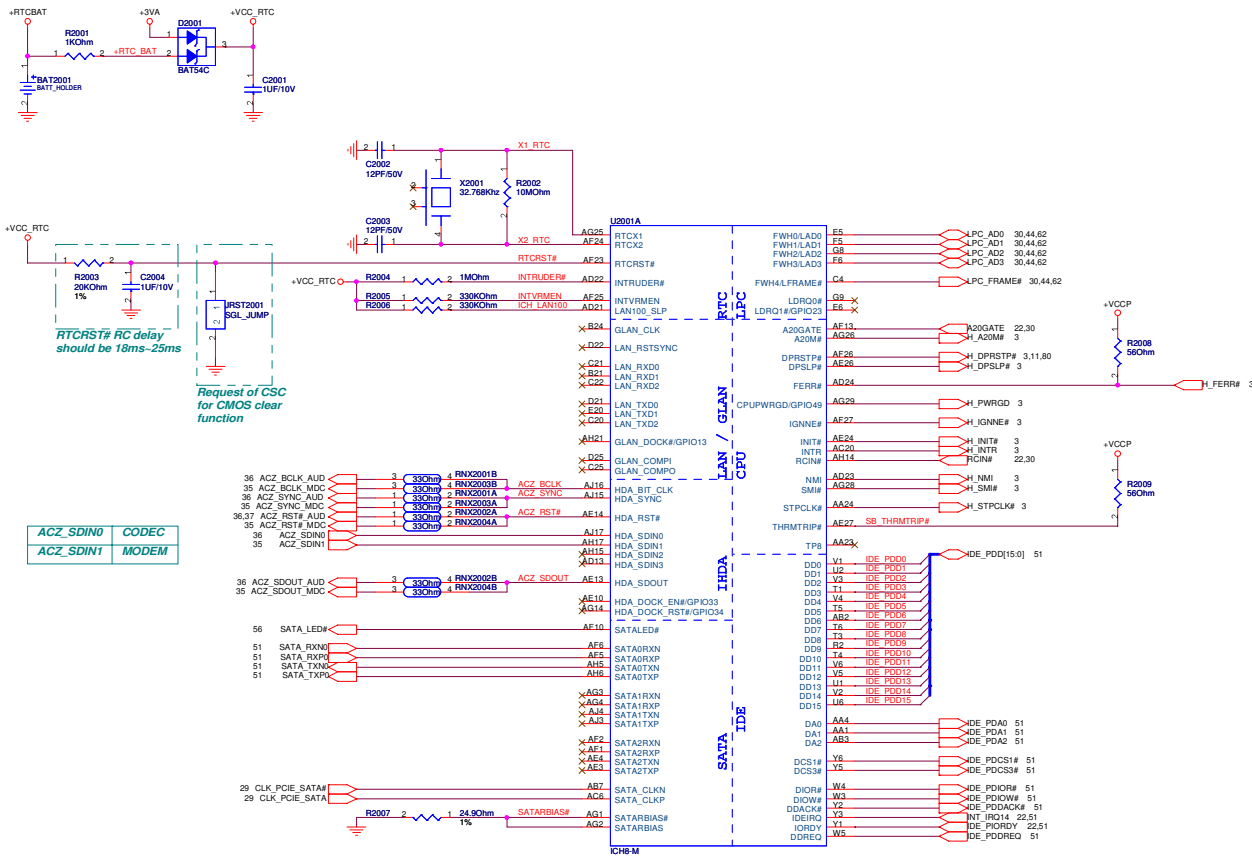

ICH_TP3, ACZ_SDOOUT : XOR Chain Entrance Strap
 00 = Reserved
 01 = Enter XOR Chain
 10 = Normal Operation (D)
 11 = Set PCIe Port Config Bit 1

GNT0#, SPI_CS1 : ICH8 Boot BIOS Select
 01 = SPI
 10 = PCI
 11 = LPC (D)

GNT2# : PCIe Port Configuration 2(Port 5/6)
 0 = Port 5 (x2)
 1 = Port 5 (x1), Port 6(x1) (D)

GNT3# : A16 Swap override strip
 0 = Enable
 1 = Default (D)

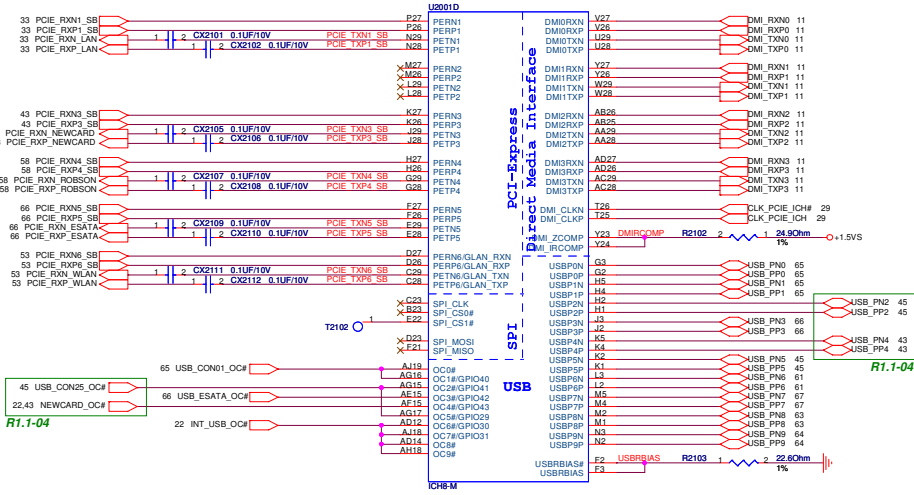
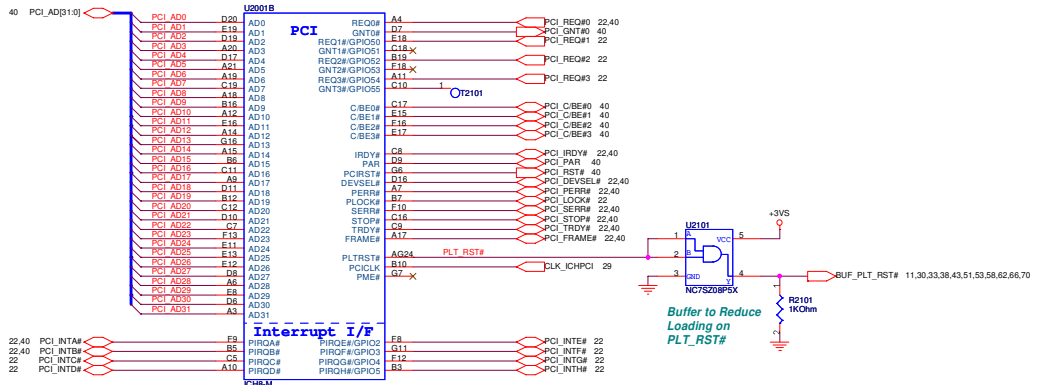

- USB 0 USB Conn.
- USB 1 USB Conn.
- USB 2 USB Conn.
- USB 3 eSATA/USB
- USB 4 NewCard
- USB 5 Camera
- USB 6 Bluetooth
- USB 7 3G Card
- USB 8 Fingerprint
- USB 9 TV Tuner

ASUS Title : SB_ICH8M(2)
 ASUSTek COMPUTER INC. NBI Engineer: John Hung
 Site: Project Name: M50S/X55S
 Date: Monday, September 03, 2007 Sheet 21 of 55

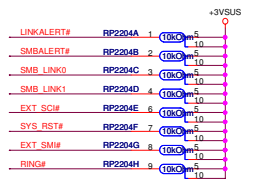
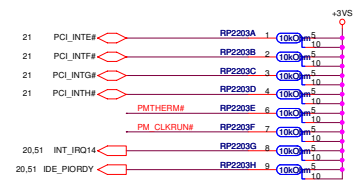
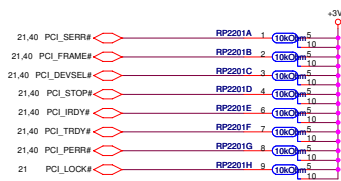
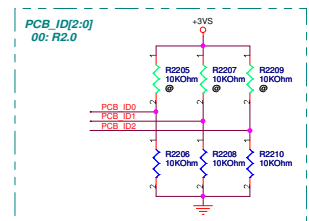
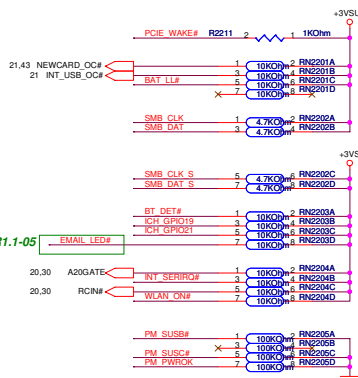
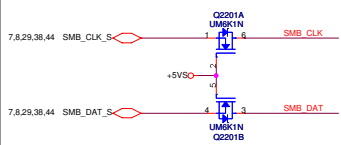
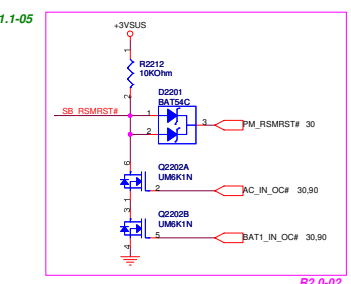
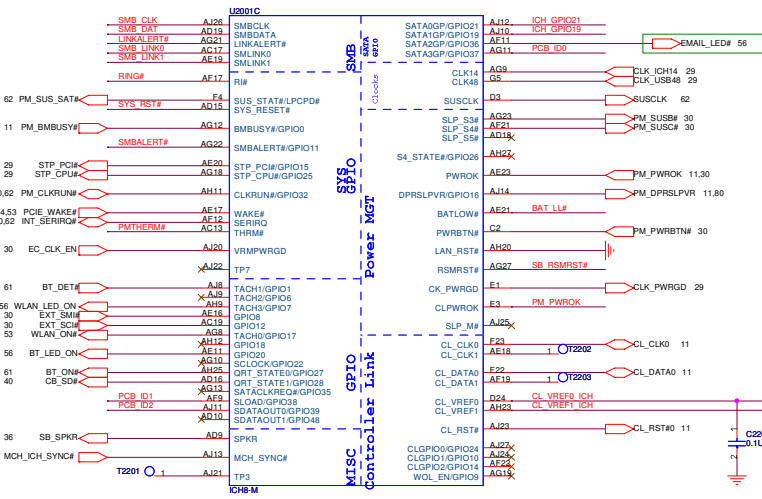

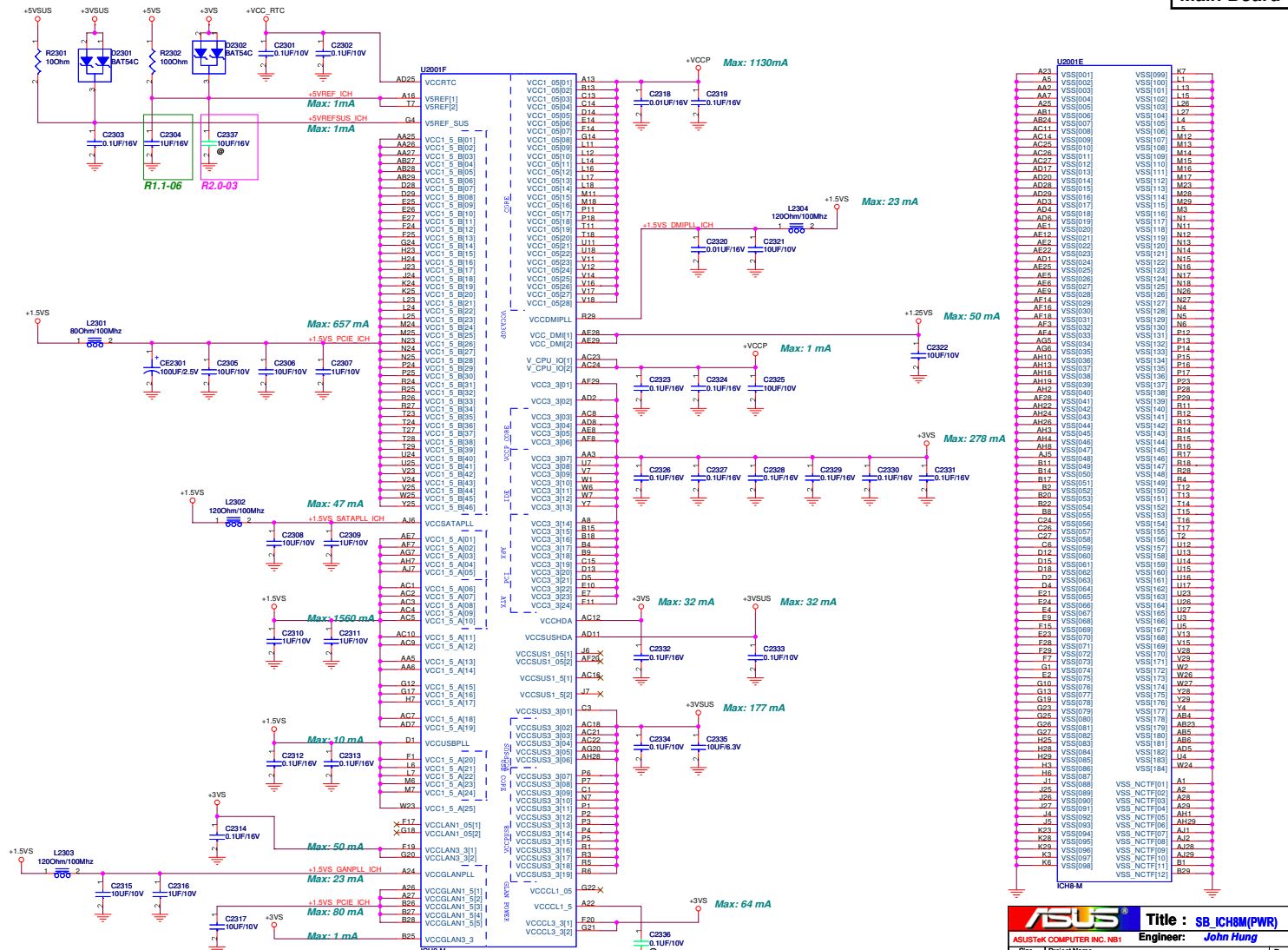

ASUS Title : SB_ICH8M(PWR)

ASUSTeK COMPUTER INC. NE1 Engineer: John Hung

Size: _____ Project Name: _____

Customer: M50S/X55S

Date: Monday, September 03, 2007 Sheet: 23 of 35

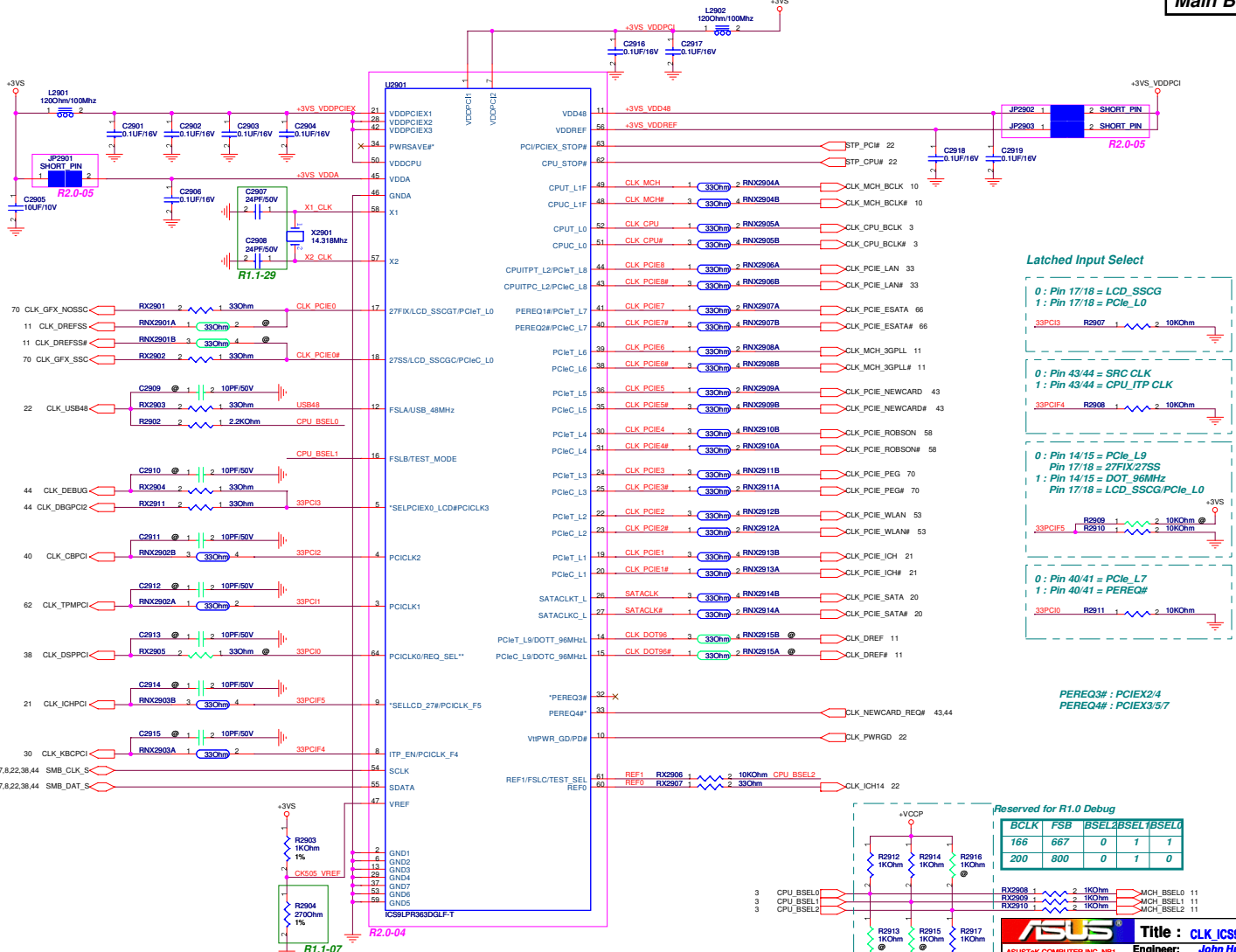

Latched Input Select

0 : Pin 17/18 = LCD_SSCG
 1 : Pin 17/18 = PCIe_L0

0 : Pin 43/44 = SRC CLK
 1 : Pin 43/44 = CPU_I7P CLK

0 : Pin 14/15 = PCIe_L9
 1 : Pin 17/18 = 27FX/27SS
 1 : Pin 14/15 = DOT_96MHz
 1 : Pin 17/18 = LCD_SSCG/PCIe_L0

PEREQ3# : PCIEX2/4
 PEREQ4# : PCIEX3/5/7

Reserved for R1.0 Debug

BCLK	FSB	BSEL2	BSEL1	BSEL0
166	667	0	1	1
200	800	0	1	0

RX2908 1 2 1KOhm MCH_BSEL0 11
 RX2909 1 2 1KOhm MCH_BSEL1 11
 RX2910 1 2 1KOhm MCH_BSEL2 11

RX2913 1 1KOhm
 RX2915 1 1KOhm
 RX2917 1 1KOhm

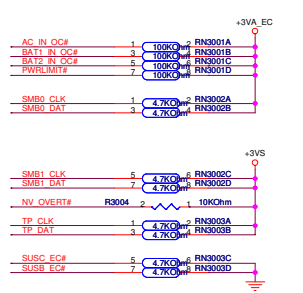
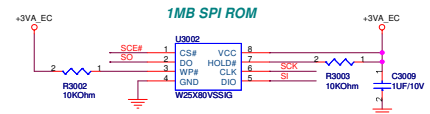
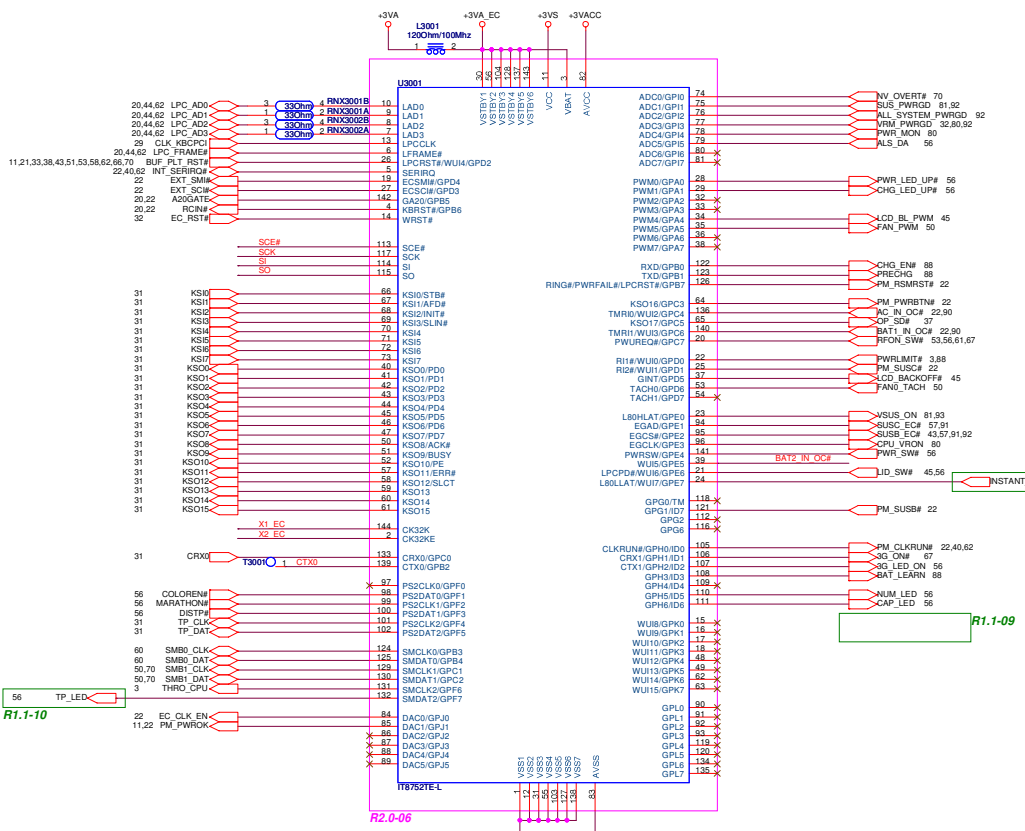
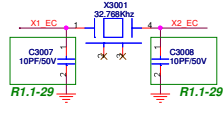
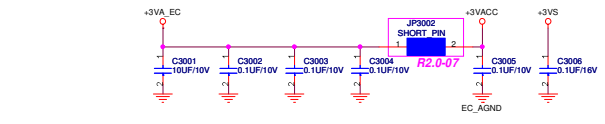

ASUS Title : KBC_IT8752
 ASUSTeK COMPUTER INC. NBI Engineer: John Hung
 Size Project Name M50S/X55S Rev
 Custom Date: Monday, September 03, 2007 Sheet 30 of 55

Keyboard

EMI

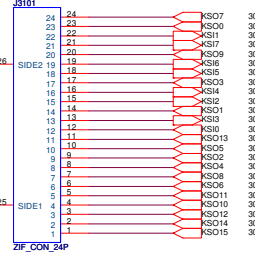
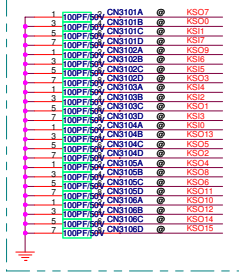

Touchpad

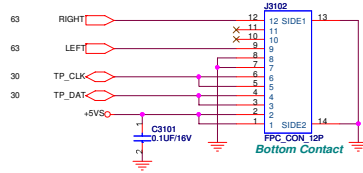

CIR

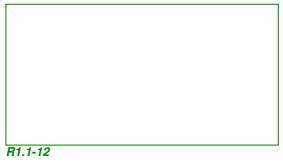
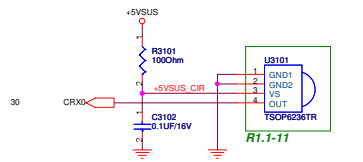

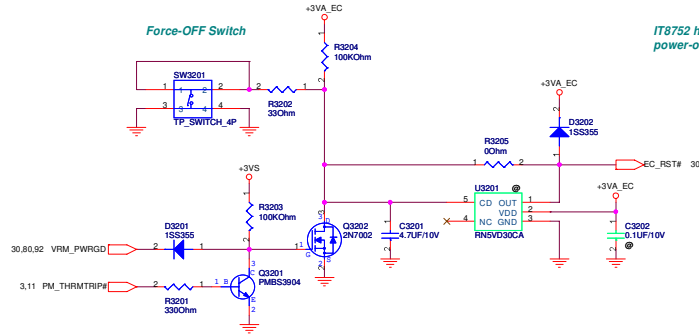

		Title : RST_Reset Circuit	
ASUSTeK COMPUTER INC. NBI		Engineer: <i>John Hung</i>	
Size	Project Name	Rev	
Custom	M50S/X55S	2.0	
Date: Monday, September 03, 2007	Sheet	32	of 88

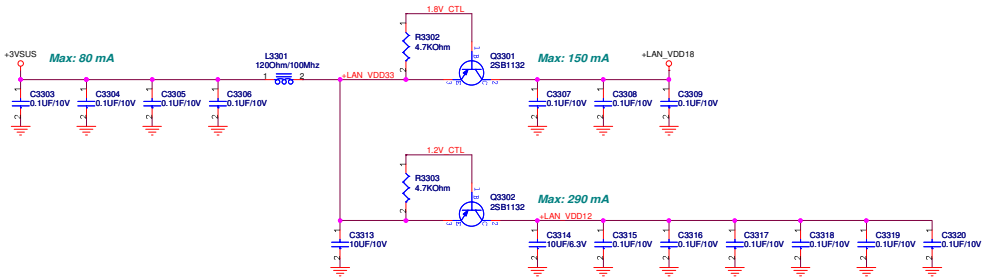
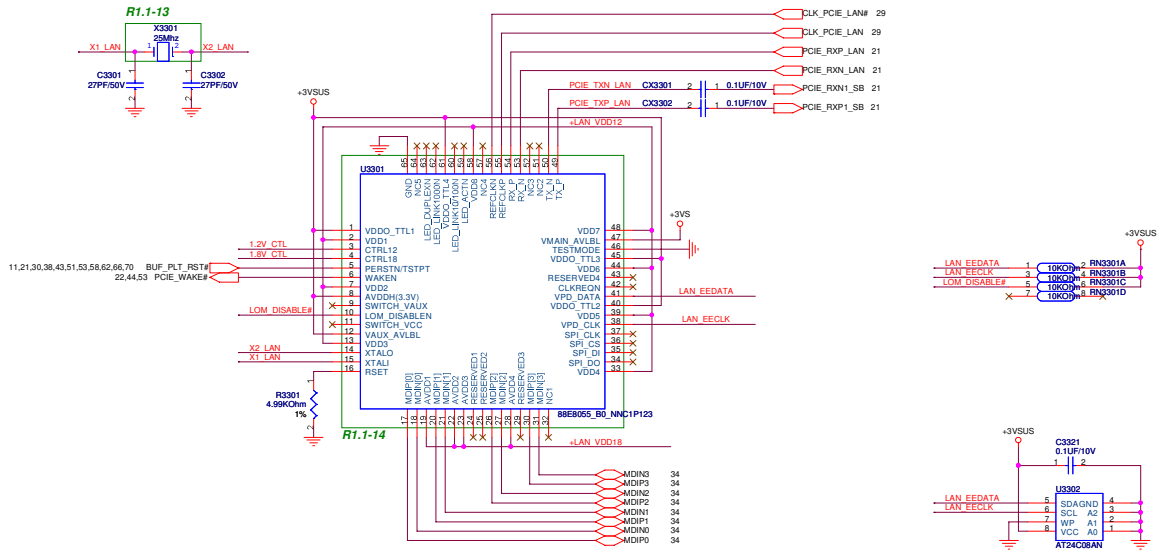

ASUS		Title : LAN_88E8055	
ASUSTek COMPUTER INC. NBI			
Engineer: John Hung			
Size	Project Name	Rev	
Custom	M50S/X55S	2.0	
Date: Monday, September 03, 2007	Sheet	33	of 88

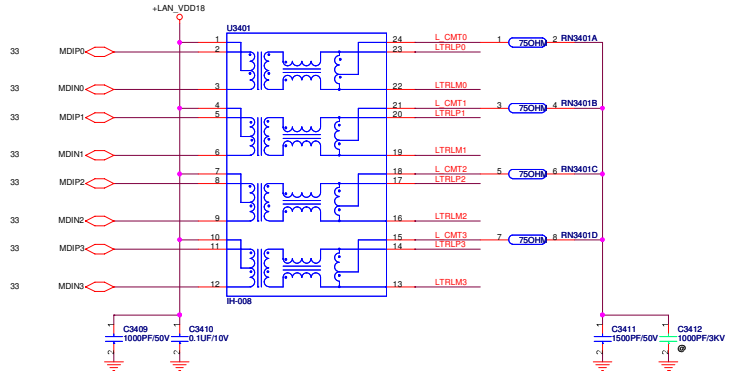
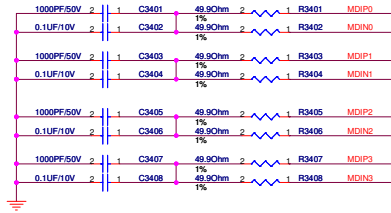

R1.1-28
R2.0-08

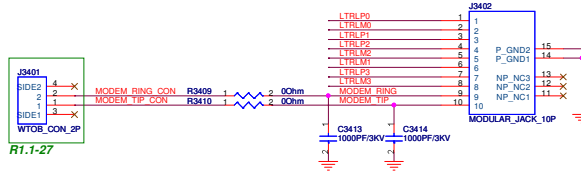

ASUS		Title : LAN RJ45 & RJ11	
ASUSTEK COMPUTER INC. NB1		Engineer: John Hung	
Size	Project Name	Rev	
Custom	M50S/X55S	2.0	
Date: Monday, September 03, 2007	Sheet	34	of 88

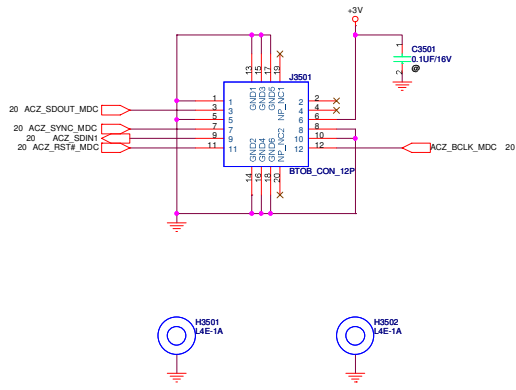

		Title : LAN_MDC	
ASUSTEK COMPUTER INC. NBI		Engineer: John Hung	
Site	Project Name		Rev
Custom	M50S/X55S		2.0
Date: Monday, September 03, 2007		Sheet	35 of 35

PM: ALC888S
GM: ALC660-VD

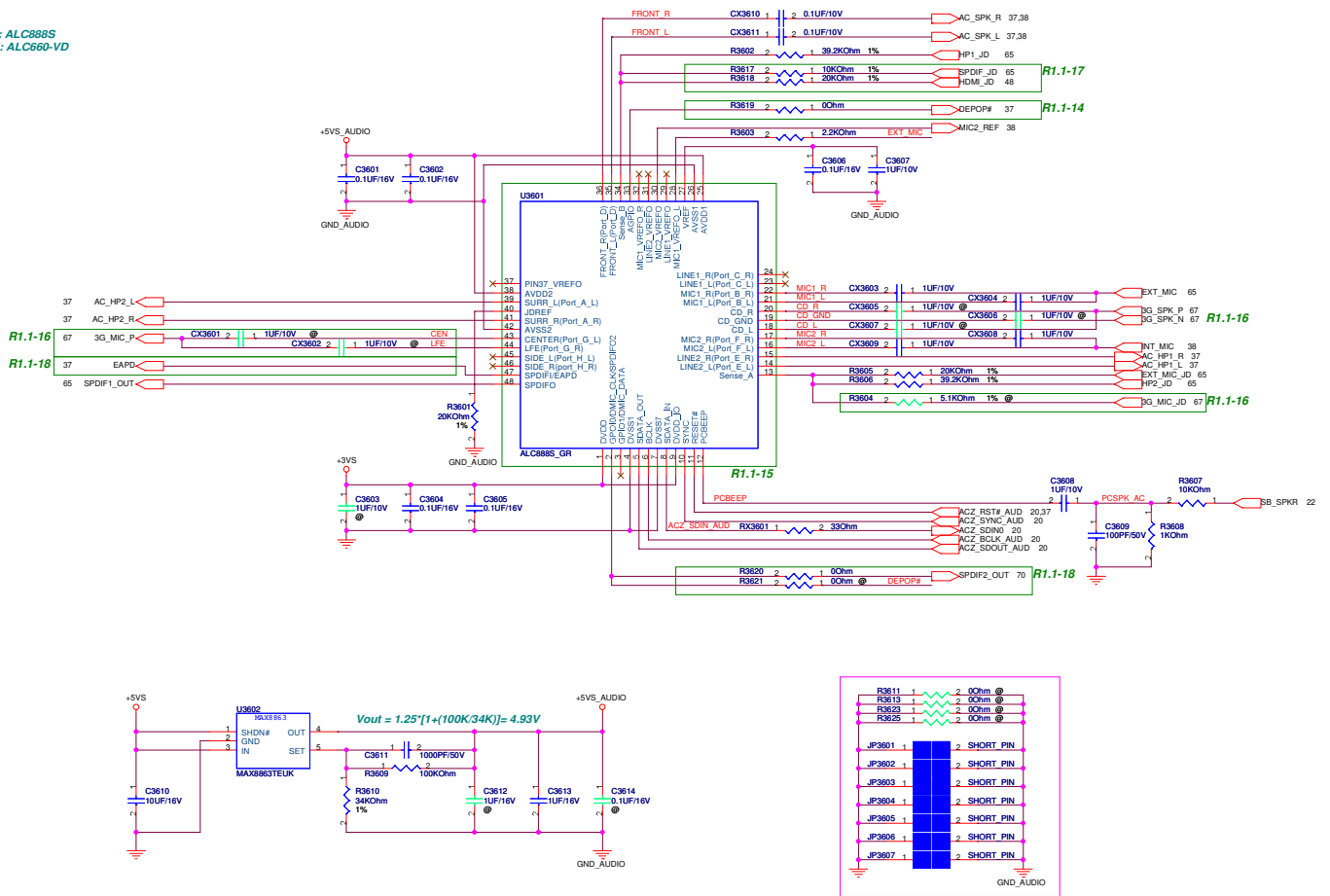

R1.1-28
R2.0-09

R3611	1	2	0Ohm	@
R3613	1	2	0Ohm	@
R3623	1	2	0Ohm	@
R3625	1	2	0Ohm	@
JP3601	1	2	SHORT PIN	
JP3602	1	2	SHORT PIN	
JP3603	1	2	SHORT PIN	
JP3604	1	2	SHORT PIN	
JP3605	1	2	SHORT PIN	
JP3606	1	2	SHORT PIN	
JP3607	1	2	SHORT PIN	

ASUS		Title : AUD_ALC888S
ASUSTek COMPUTER INC. NBI		Engineer: John Hung
Size	Project Name	Rev
Custom	M50S/X55S	2.0
Date: Monday, September 03, 2007	Sheet	36 of 55

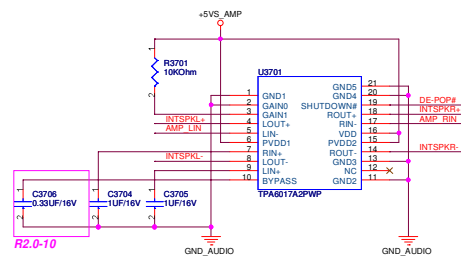
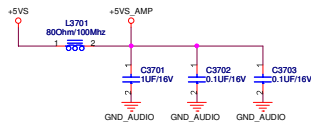

Internal Speaker Conn.

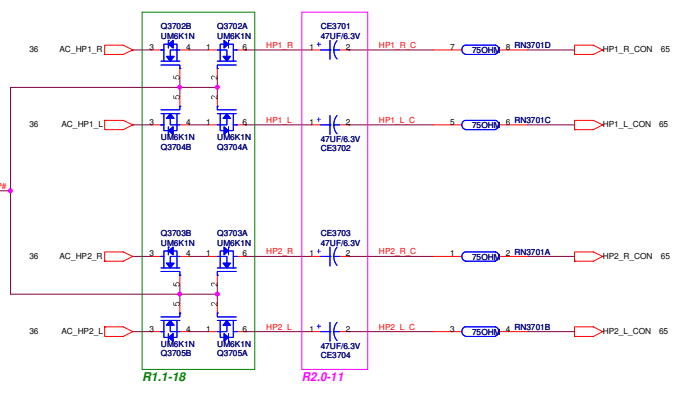
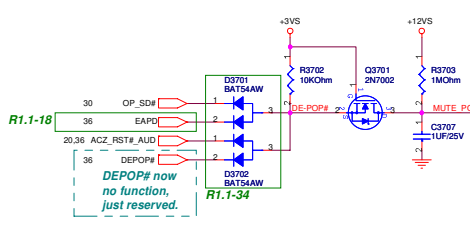
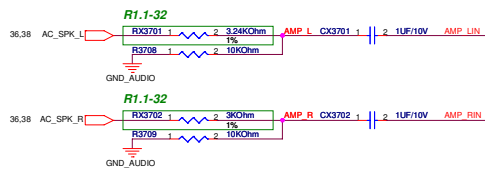
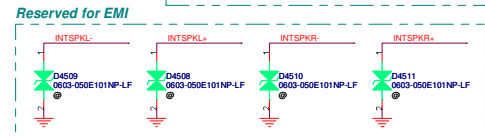
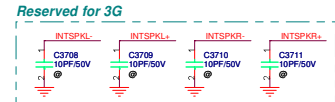
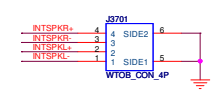

R1.1-18
DEPOP# now no function, just reserved.

ASUS		Title : AUD_Amp & Jack
ASUSTEK COMPUTER INC. NBI		Engineer: John Hung
Size	Project Name	Rev
Custom	M50S/X55S	2.0
Date: Wednesday, September 05, 2017	Sheet	37 of 38

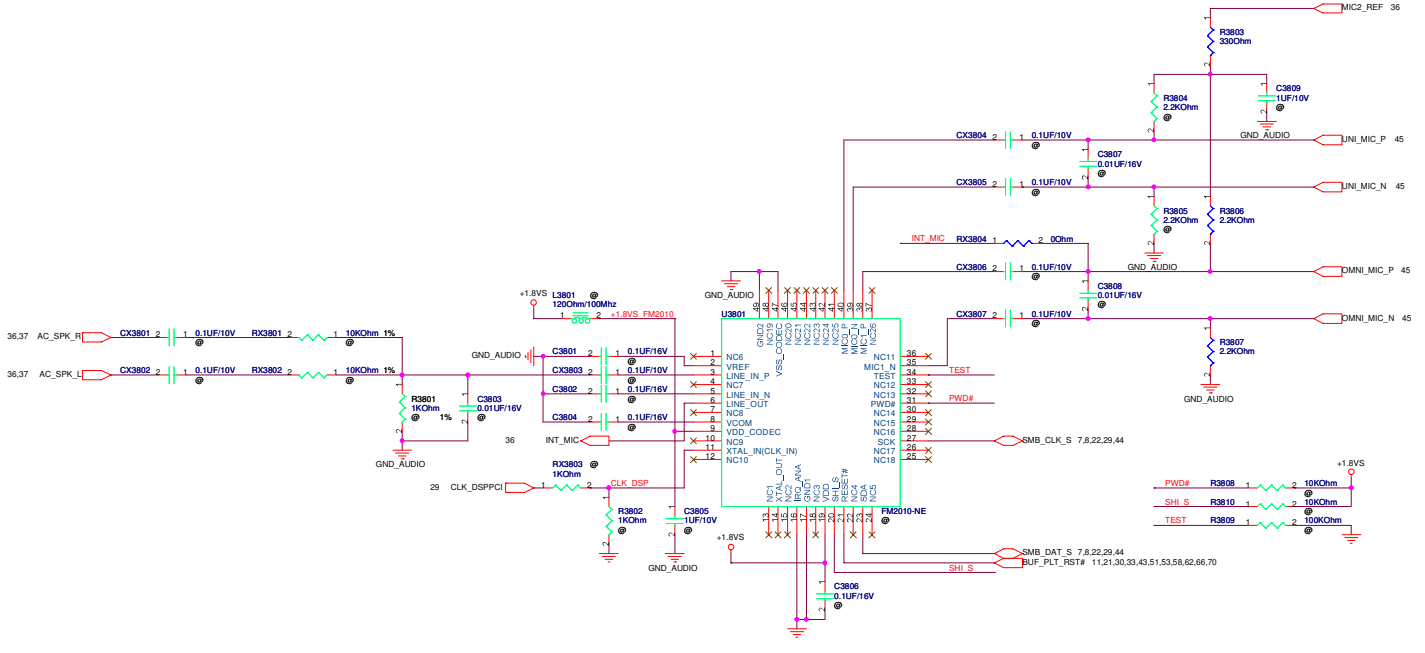

		Title : AUD_FM2010
ASUSTEK COMPUTER INC. NB1		Engineer: John Hung
Size	Project Name	Rev
Custom	M50S/X55S	2.0
Date: Tuesday, September 04, 2007	Sheet	38 of 88

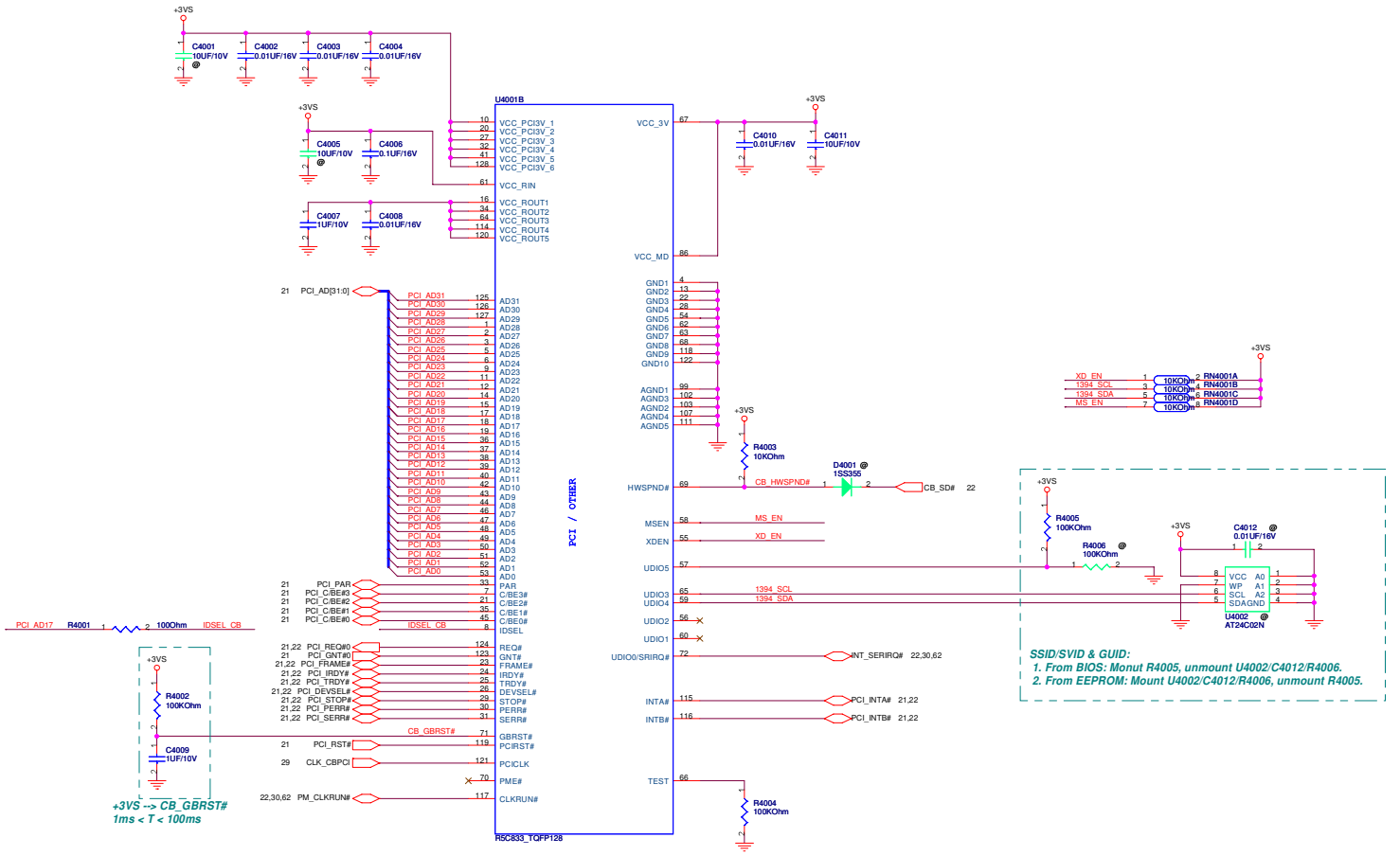

ASUS		Title : CB_R5C833
ASUSTEK COMPUTER INC. NB1		Engineer: John Hung
Size	Project Name	Rev
Custom	M50S/X55S	2.0
Date: Monday, September 03, 2007	Sheet	40 of 88

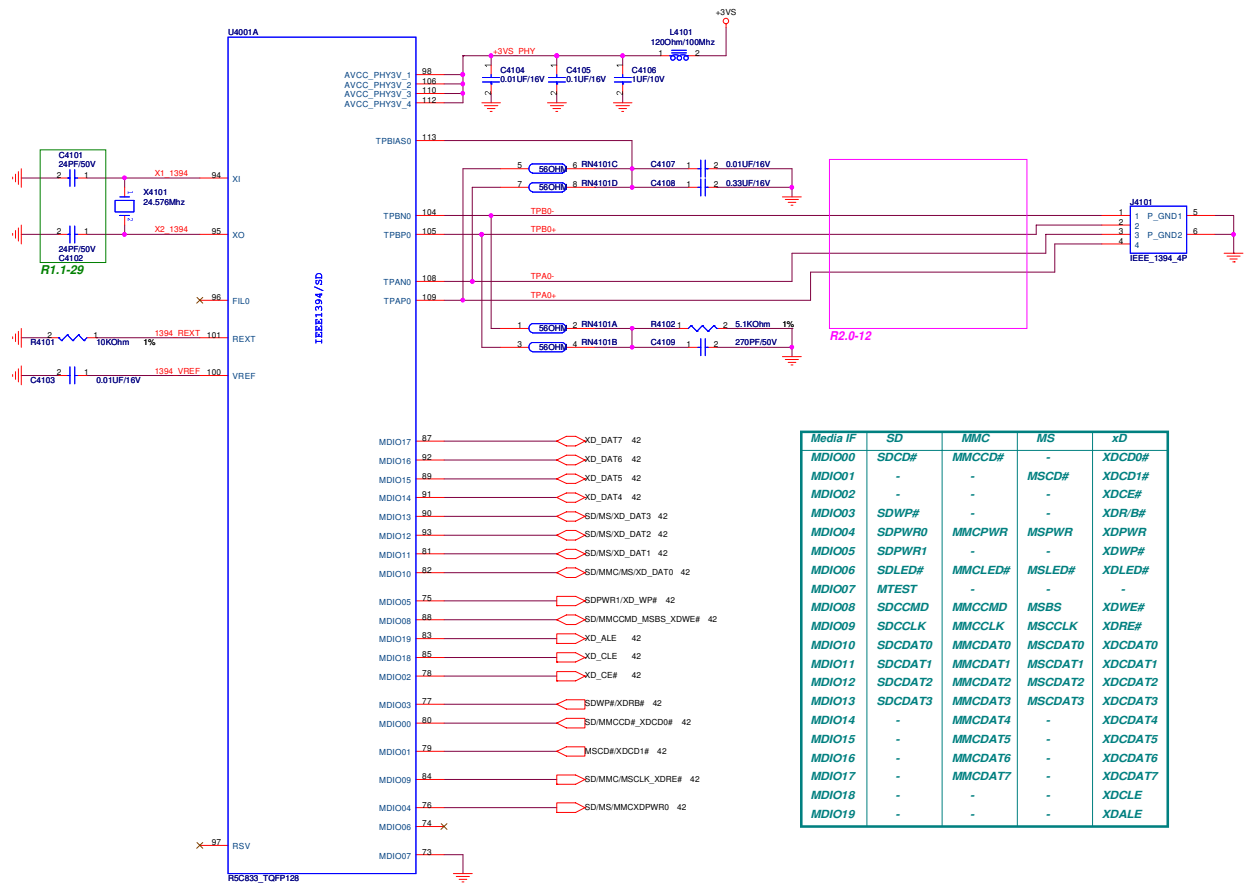

ASUS Title : CB_R5C833
 ASUSTek COMPUTER INC. NE1 Engineer: John Hung
 Project Name: M50S/X55S
 Date: Monday, September 03, 2007 Sheet 41 of 88

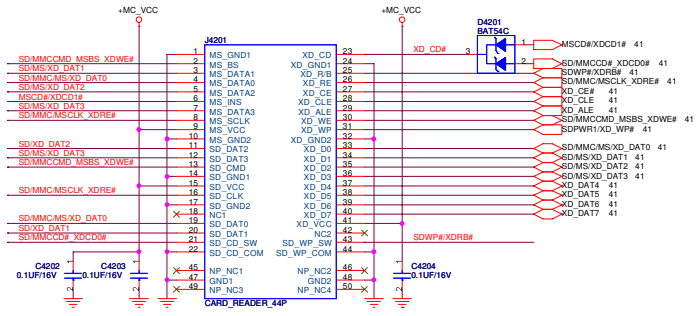
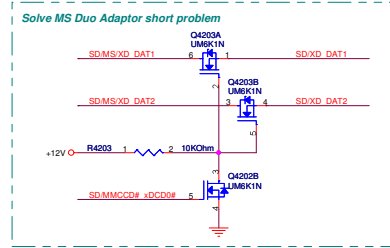
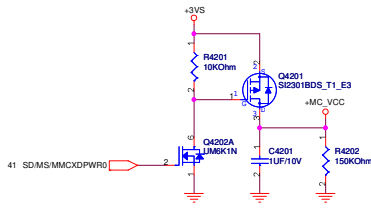

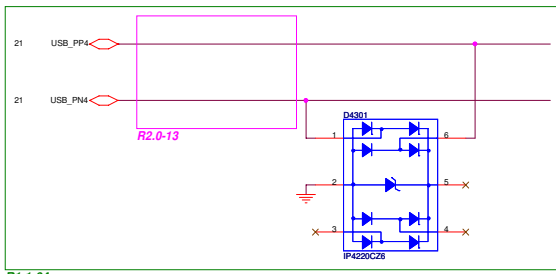

R1.1-04

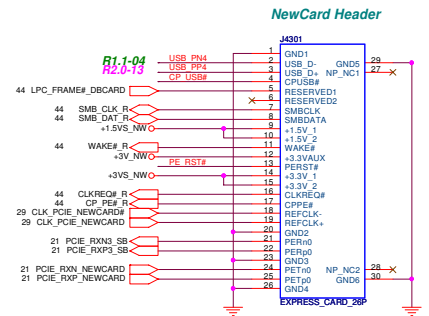
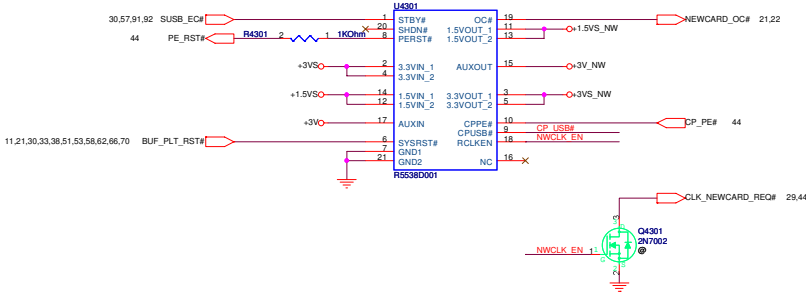

NewCard Ejector

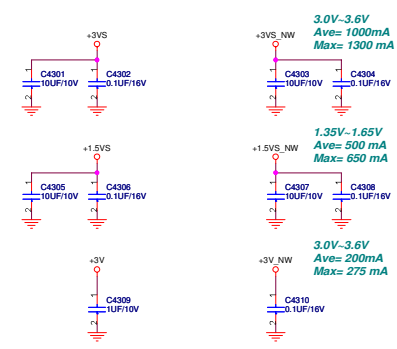
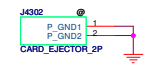

ASUS		Title : CB_NewCard	
ASUSTek COMPUTER INC. NBI		Engineer: John Hung	
Size	Project Name	Rev	
Custom	M50S/X55S	1.0	
Date: Monday, September 03, 2007	Sheet	43	of 88

LPC Debug Port

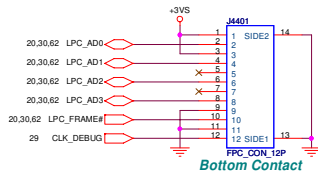

For NewCard Debug Card

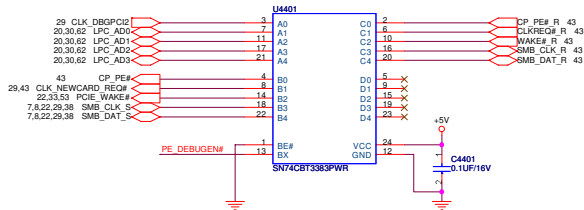

CP_PE#	@ 00hm	2	1	R4405	CP_PE# R
CLK_NEWCARD_REQ#	@ 00hm	4	4	R4401B	CLK_REQ# R
PCIE_WAKE#	@ 00hm	1	2	R4401A	WAKE# R
SMB_DAT# S	@ 00hm	4	4	R4402B	SMB_DAT# R
SMB_CLK# S	@ 00hm	2	2	R4402A	SMB_CLK# R

R2.0-14

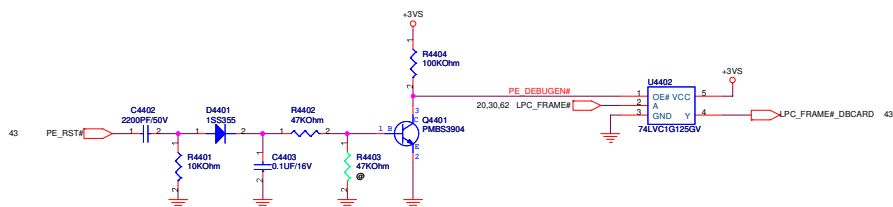

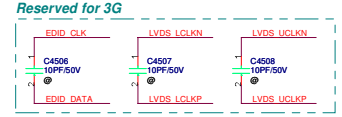
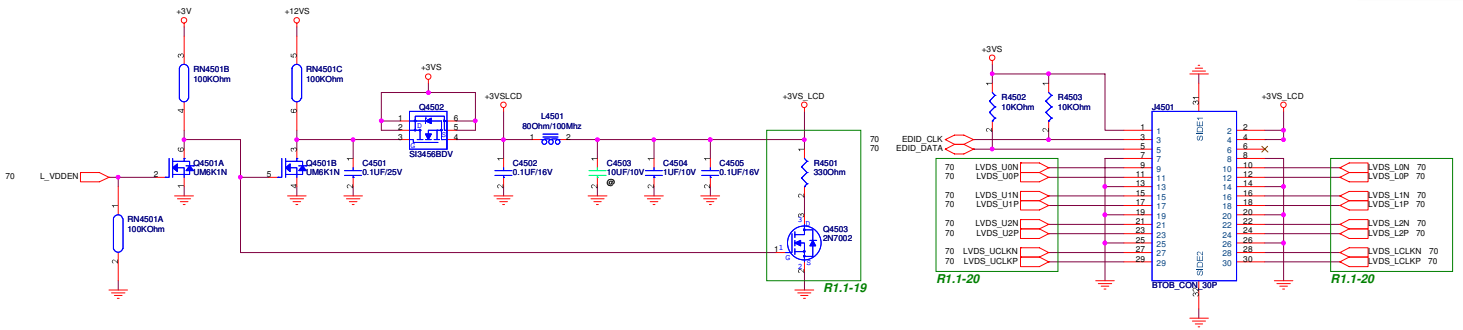

X 7 100K Ohm RN4501D

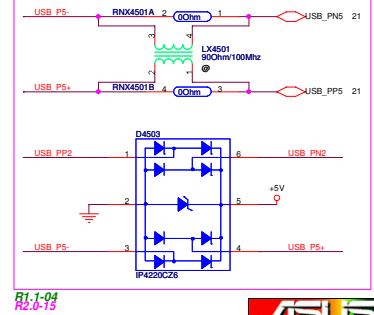
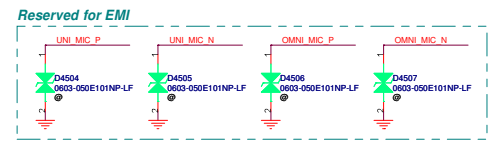
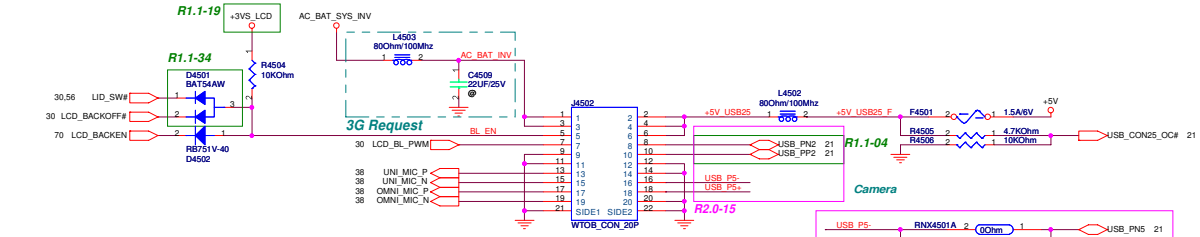

R1.1-04
R2.0-15

ASUS		Title : CRT_LCD Panel	
ASUSTek COMPUTER INC. NBI		Engineer: John Hung	
Size	Project Name	Rev	
Custom	M50S/X55S	2.0	
Date: Monday, September 03, 2007		Sheet	45 of 85

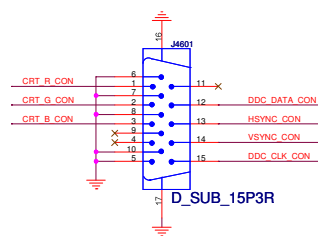
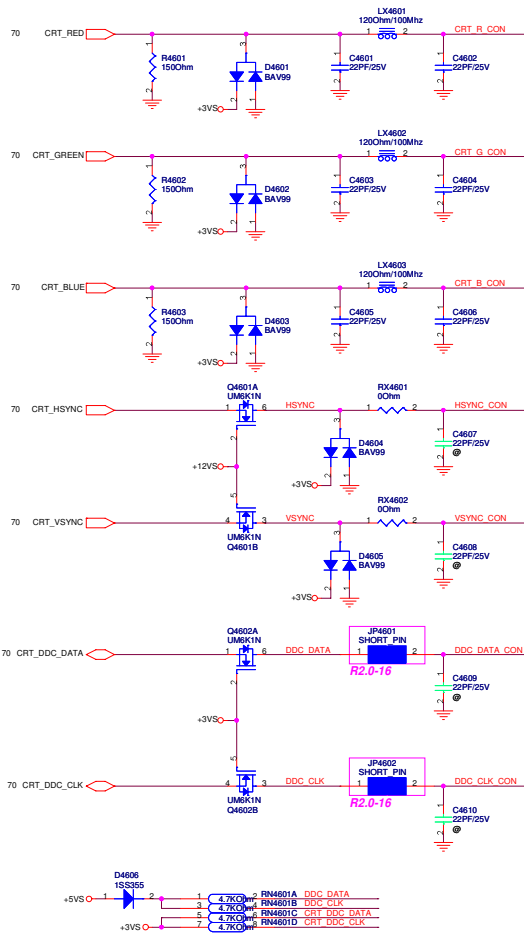

ASUS		Title : CRT_D-Sub	
ASUSTek COMPUTER INC. NBI		Engineer: John Hung	
Size	Project Name	Rev	
Custom	M50S/X55S	2.0	
Date: Monday, September 03, 2007	Sheet	46	of 88

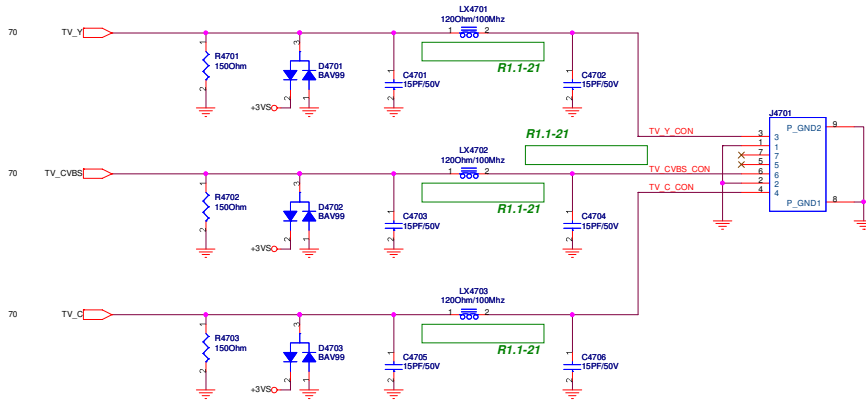

ASUS		Title : TV_TV-Out	
ASUSTEK COMPUTER INC. NBI		Engineer: John Hung	
Site	Project Name		Rev
Custom	M50S/X55S		2.0
Date: Monday, September 03, 2007		Sheet 47 of 88	

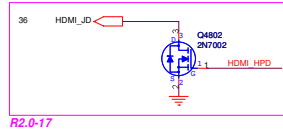
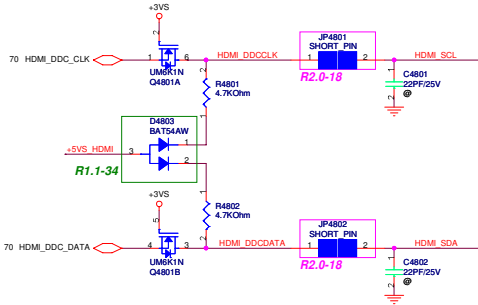
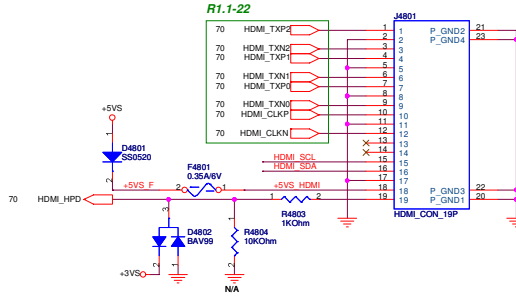
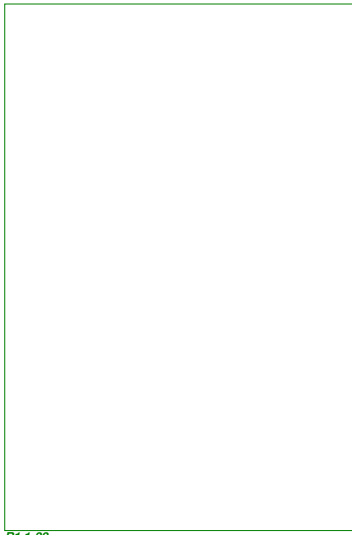

ASUS		Title : CRT_HDMI	
ASUSTek COMPUTER INC. NBI		Engineer: John Hung	
Size	Project Name	Rev	
Custom	M50S/X55S	2.0	
Date: Monday, September 03, 2007	Sheet	48	of 88

CPU Thermal Sensor

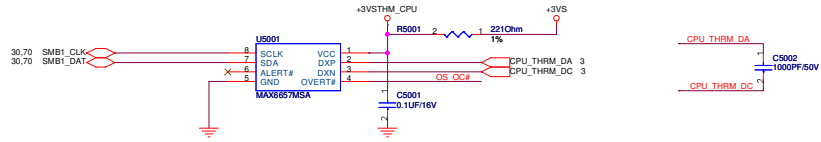

PWM Fan

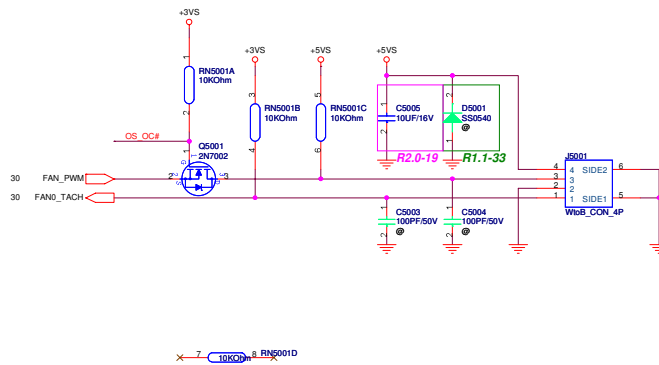

ASUS		Title : FAN_Fan & Sensor	
ASUSTeK COMPUTER INC. NBI		Engineer: John Hung	
Size	Project Name		Rev
Custom	M50S/X55S		2.0
Date: Monday, September 03, 2007	Sheet	50	of 55

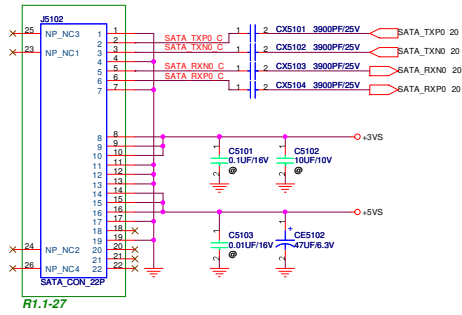
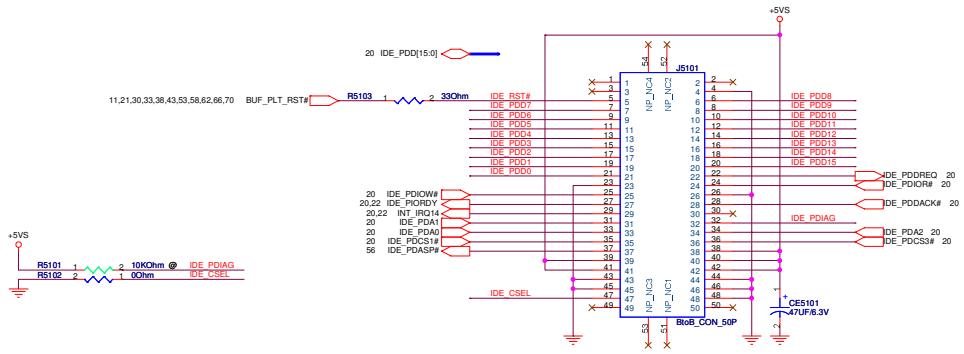

ASUS		Title : XDD_HDD & ODD	
ASUSTeK COMPUTER INC. NBI		Engineer: John Hung	
Size	Project Name	Rev	2.0
Custom	M50S/X55S	Date:	Monday, September 03, 2007
		Sheet	51 of 88

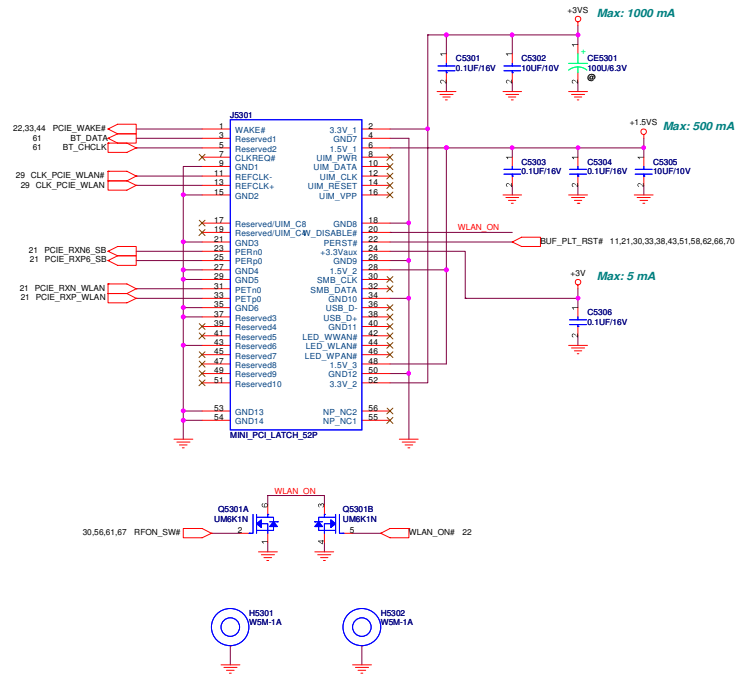

ASUS		Title : PCI WLAN	
ASUSTek COMPUTER INC. NBI		Engineer: John Hung	
Size	Project Name	Rev	
Custom	M50S/X55S	2.0	
Date: Tuesday, September 04, 2017	Sheet	53	of 85

		Title : SIO ****	
ASUSTEK COMPUTER INC. NBI		Engineer: John Hung	
Site	Project Name		Rev
Custom	M50S/X55S		2.0
Date: Monday, September 03, 2007		Sheet	55 of 55

Power LED

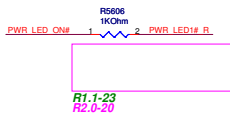

R1.1-23
R2.0-20

Cap Lock LED

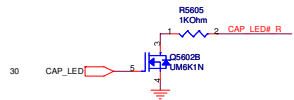

Num Lock LED

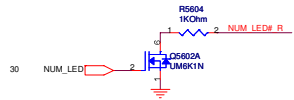

HDD & ODD LED

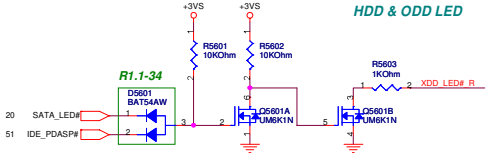

R1.1-34

E-Mail LED

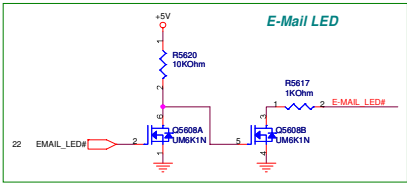

R1.1-03

Touch-pad Lock LED

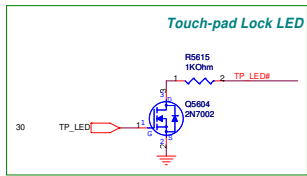

R1.1-08

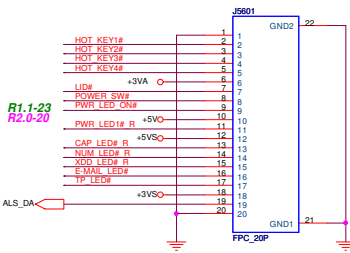

R1.1-23
R2.0-20

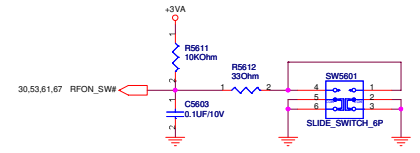

Power LED

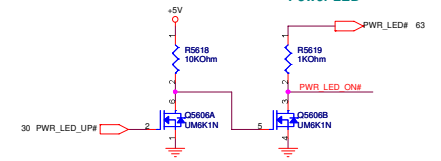

Charger LED

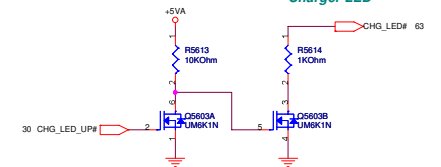

WLAN LED

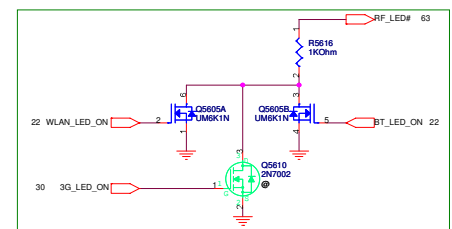

R1.1-24

ASUS		Title : LED Indicator	
ASUSTek COMPUTER INC. NBI		Engineer: John Hung	
Size	Project Name	Rev	
Custom	M50S/X555	2.0	
Date: Tuesday, September 04, 2007	Sheet	56	of 88

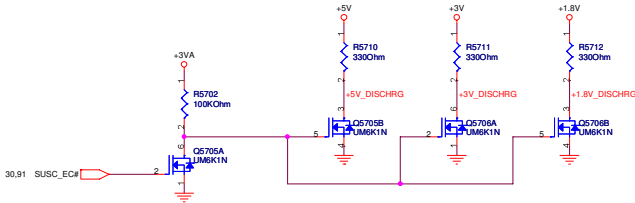
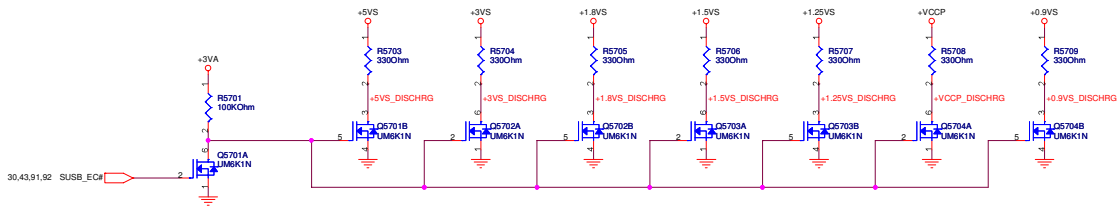

		Title : DSG Discharge	
ASUSTek COMPUTER INC. NB1		Engineer: John Hung	
Size	Project Name	Rev	
Custom	M50S/X55S	2.0	
Date: Monday, September 03, 2007		Sheet	57 of 88

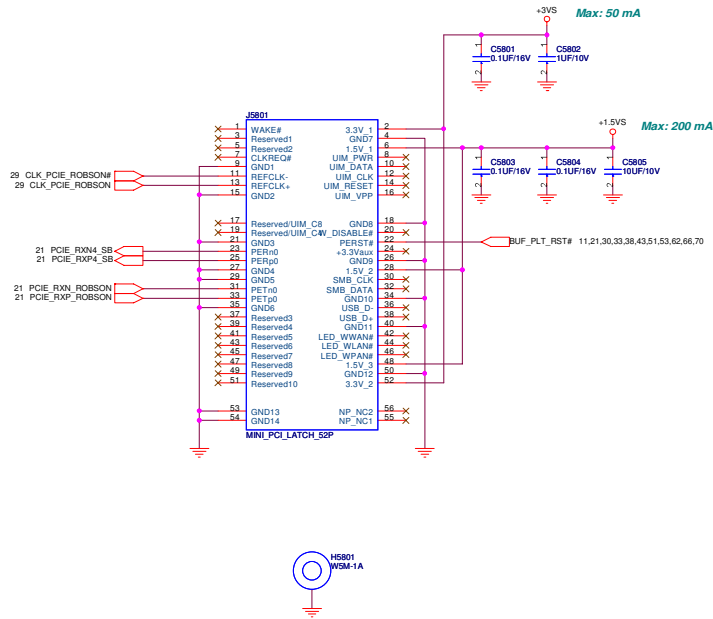

ASUS		Title : ROB_Robson	
ASUSTEK COMPUTER INC. NB1		Engineer: John Hung	
Size	Project Name		Rev
Custom	M50S/X55S		2.0
Date: Monday, September 03, 2007		Sheet	58 of 88

DC Jack

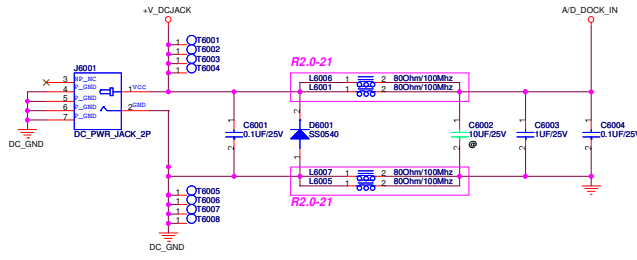

Battery Connector

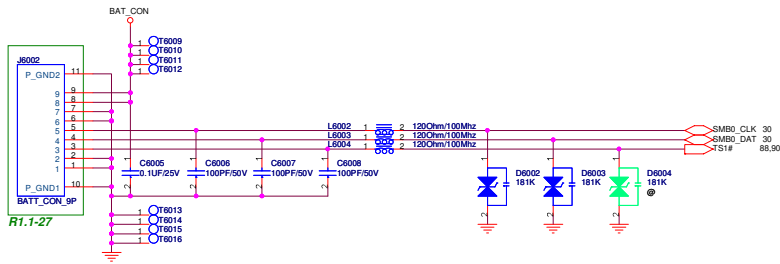

ASUS		Title : DC_DC & BAT Conn.	
ASUSTEK COMPUTER INC. NBI		Engineer: John Hung	
Size	Project Name	Rev	
Custom	M50S/X55S	2.0	
Date: Monday, September 03, 2007	Sheet	60	of 88

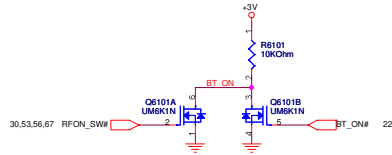
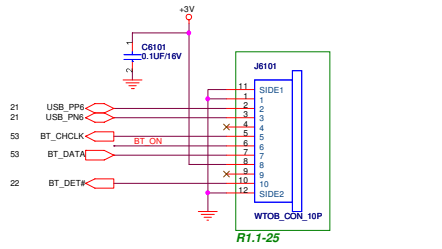

ASUS		Title : BT Bluetooth	
ASUSTEK COMPUTER INC. NBI		Engineer: John Hung	
Site	Project Name	Rev	
Custom	M50S/X55S	2.0	
Date: Monday, September 03, 2007	Sheet	61	of 88

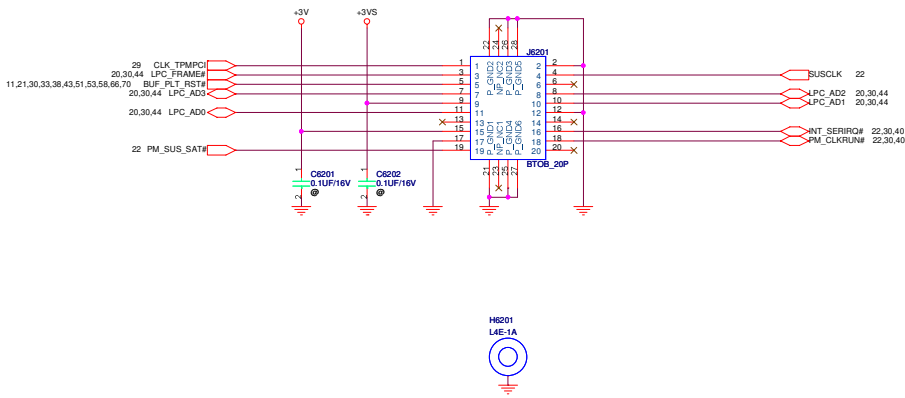

		Title : TPM TPM 1.2	
ASUSTEK COMPUTER INC. NBI		Engineer: John Hung	
Site	Project Name	Rev	
Custom	M50S/X55S	2.0	
Date: Monday, September 03, 2007	Sheet	62	of 88

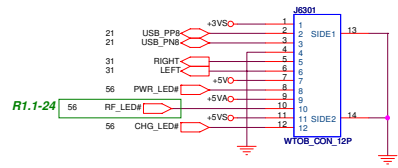

		Title : FP Fingerprint Conn.	
ASUSTEK COMPUTER INC. NB1		Engineer: John Hung	
Site	Project Name		Rev
Custom	M50S/X55S		2.0
Date: Monday, September 03, 2007		Sheet	63 of 88

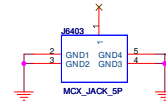
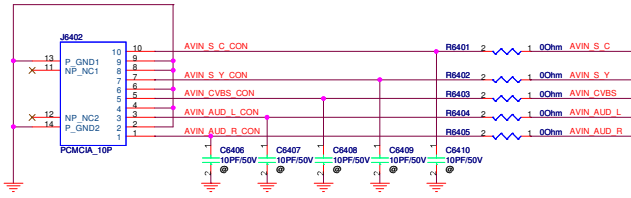
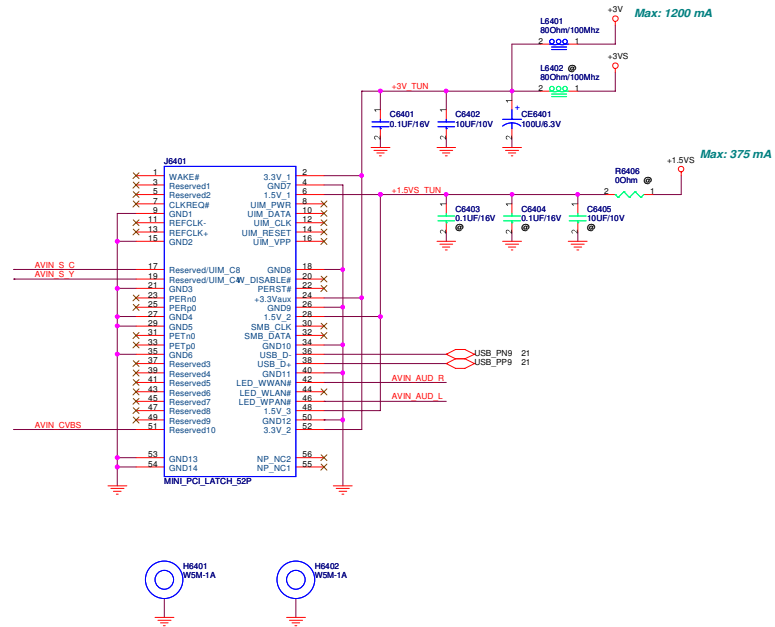

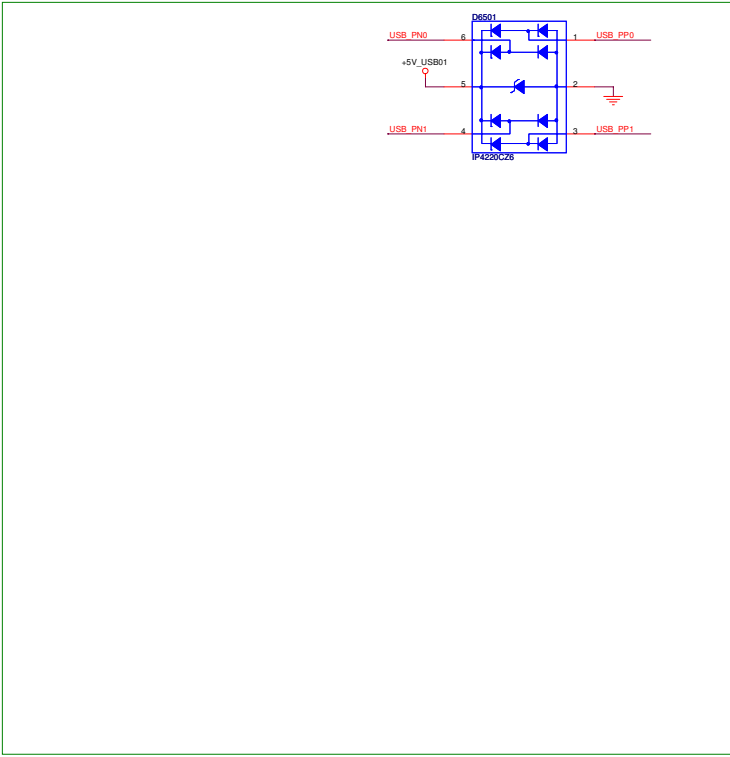
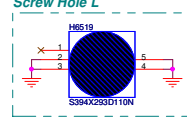
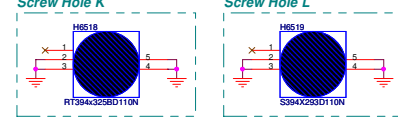
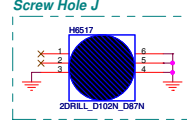
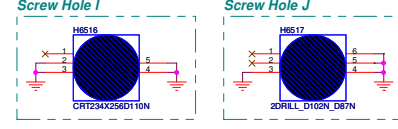
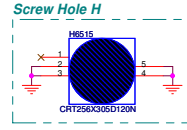
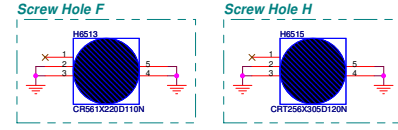
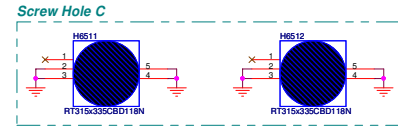
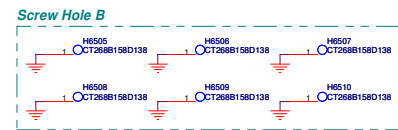
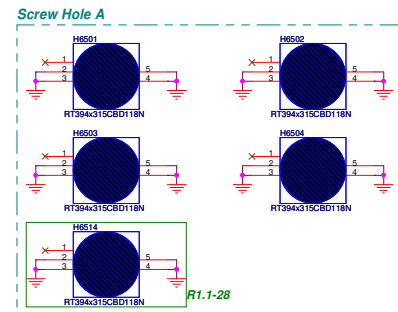
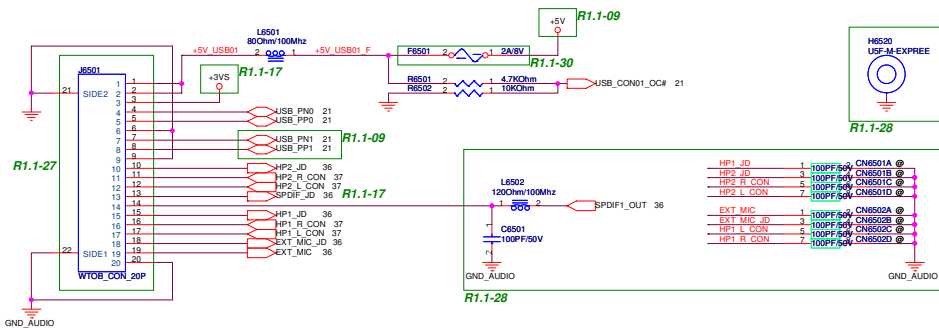

ASUS Title : ME_Conn & Screw Holes
 ASUSTEK COMPUTER INC. NBI Engineer: John Hung
 Project Name: M50S/X55S
 Date: Monday, September 03, 2007 Sheet: 65 of 85

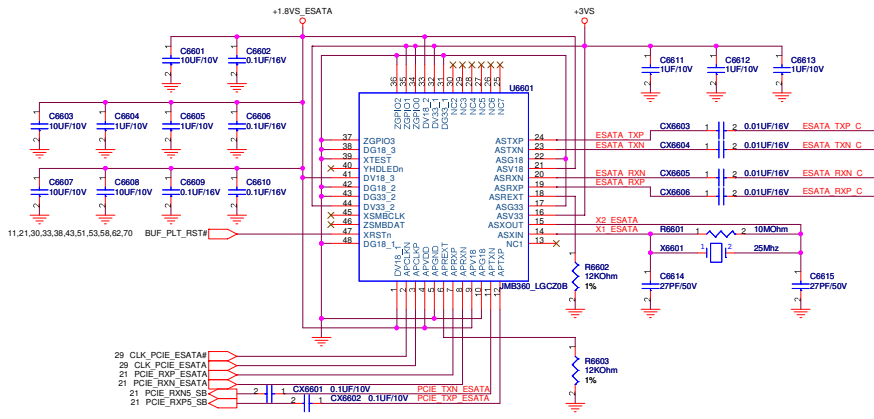

- ZGPIO : Clock Type of PCI Express
0 = 25MHz Oscillator (D)
1 = 100MHz from PCI Express Finger
- ZGPIO1 : Clock Source of SATA II
0 = from Internal Clock Source (D)
1 = from ASXIN & ASXOUT
- ZGPIO2 : Interface to Debug Registers
0 = SMBus I/F (D)
1 = Reserved
- ZGPIO3 : SMBus ID Address
0 = 8'h44 (D)
1 = 8'h4A

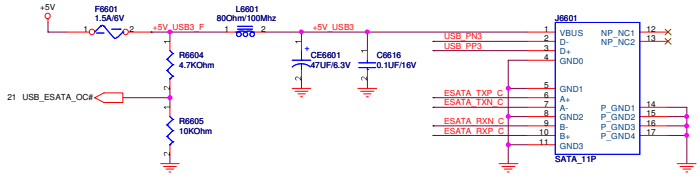
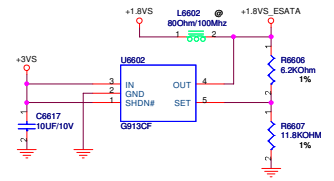
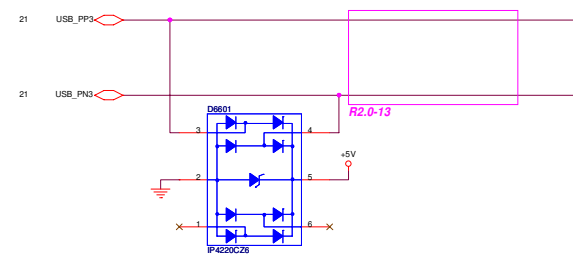

ASUS		Title : ESA_JMB360	
ASUSTek COMPUTER INC. NBI		Engineer: John Hung	
Size	Project Name	Rev	2.0
Custom	M50S/X55S	Date	Monday, September 03, 2007
		Sheet	66 of 88

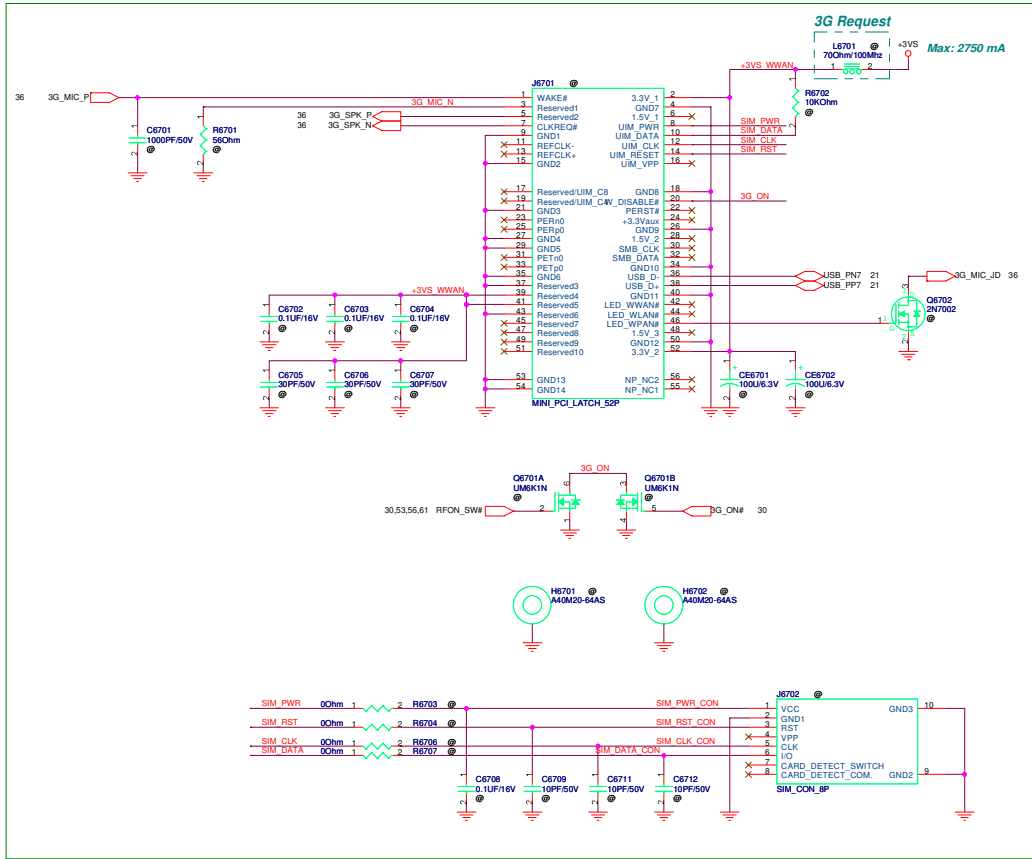

R1.1-16

ASUS		Title : WAN_WWAN	
ASUSTek COMPUTER INC. NBI		Engineer: John Hung	
Size	Project Name	Rev	
Custom	M50S/X55S	2.0	
Date: Monday, September 03, 2007	Sheet	67	of 88

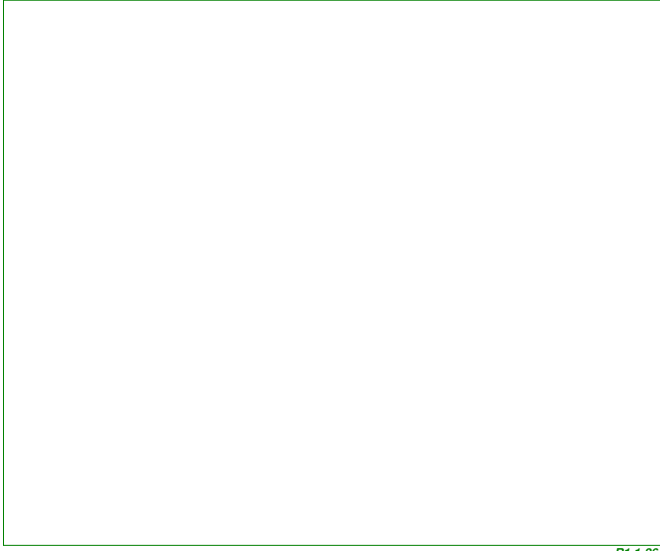

R1.1-26

		Title : OTH_****	
ASUSTEK COMPUTER INC. NBI		Engineer: John Hung	
Size	Project Name		Rev
Custom	M50S/X55S		2.0
Date: Monday, September 03, 2007		Sheet	68 of 88

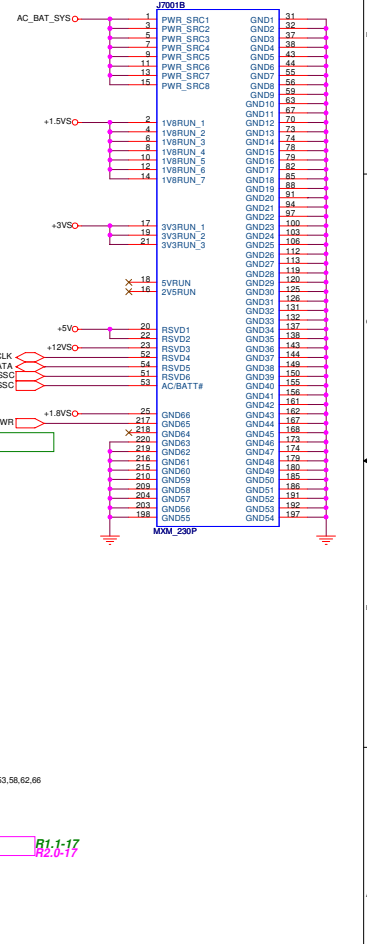
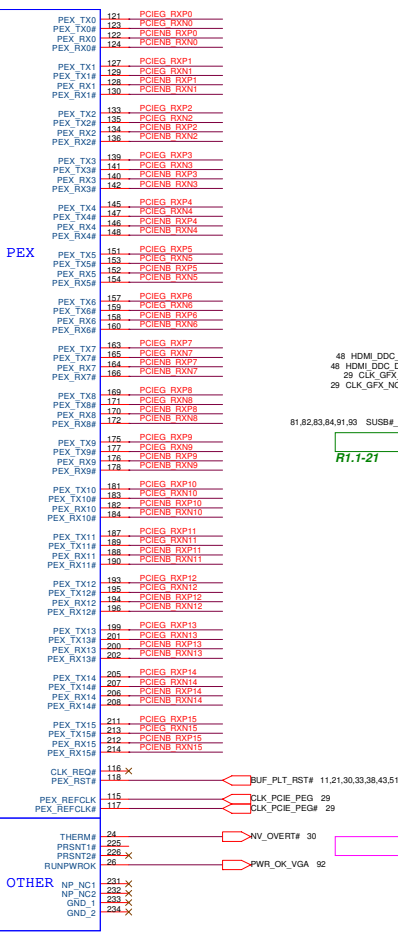
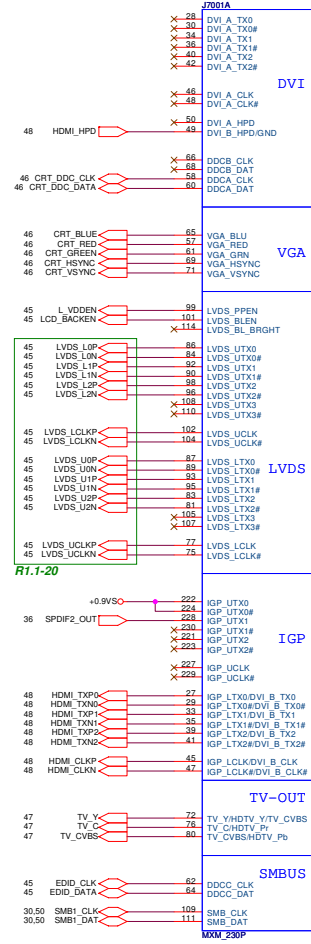
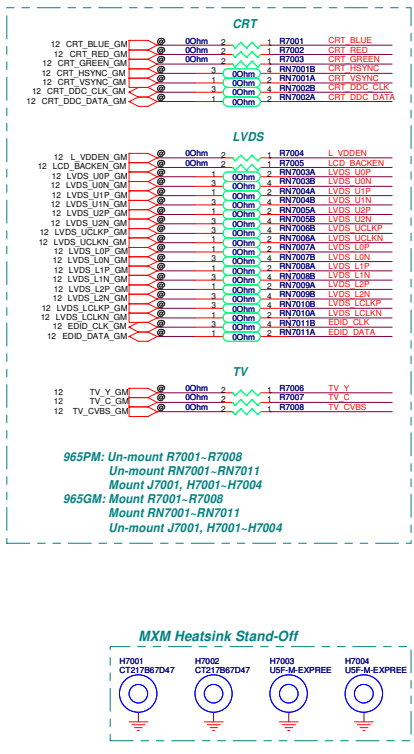
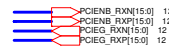

ASUS Logo | Title : VGA_MXM | ASUSTek COMPUTER INC. H61 | Engineer: John Hung | Project Name: M50S/X55S | Date: Monday, September 03, 2007 | Sheet: 70 of 85

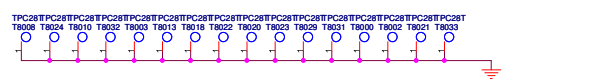
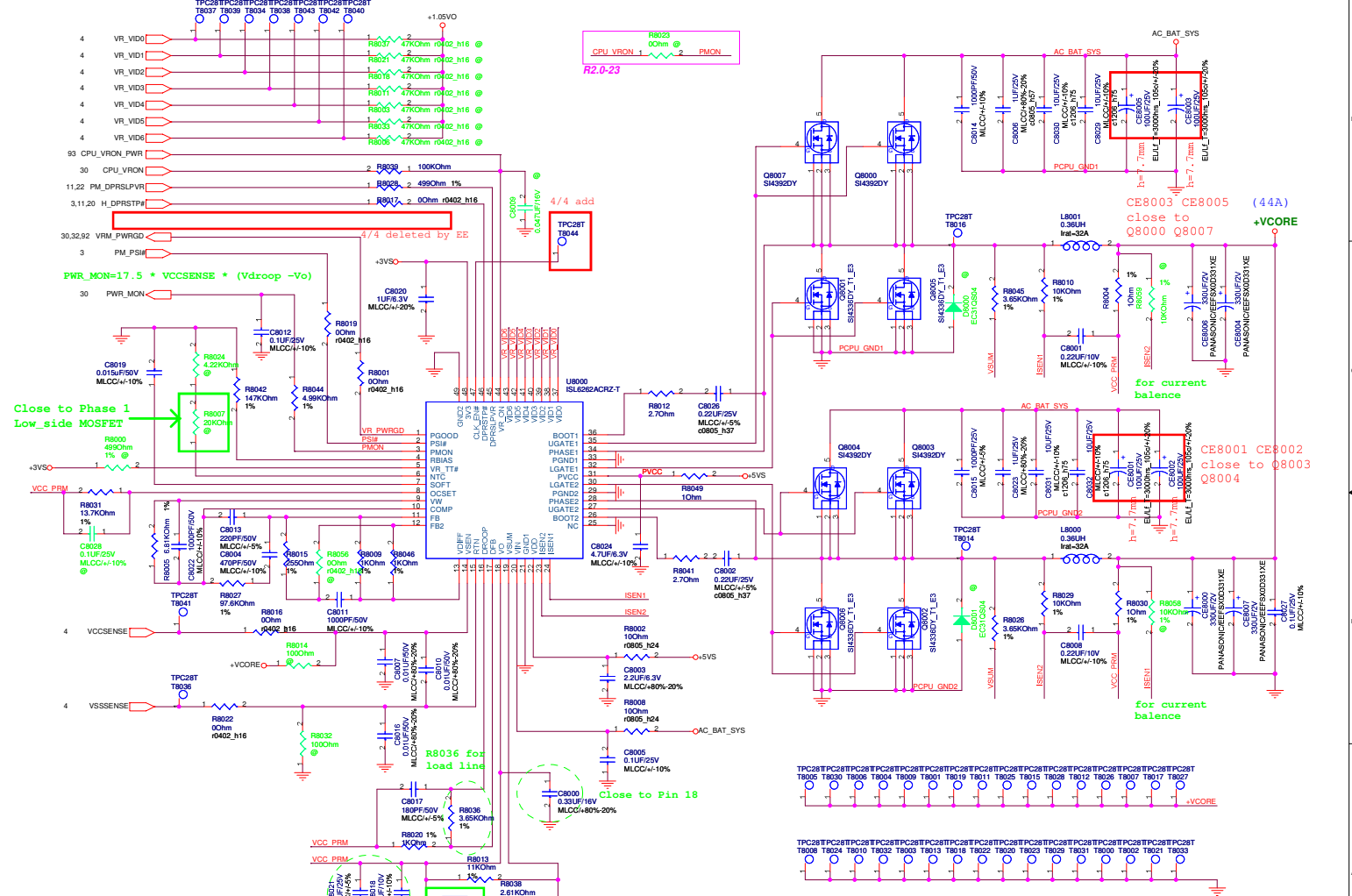

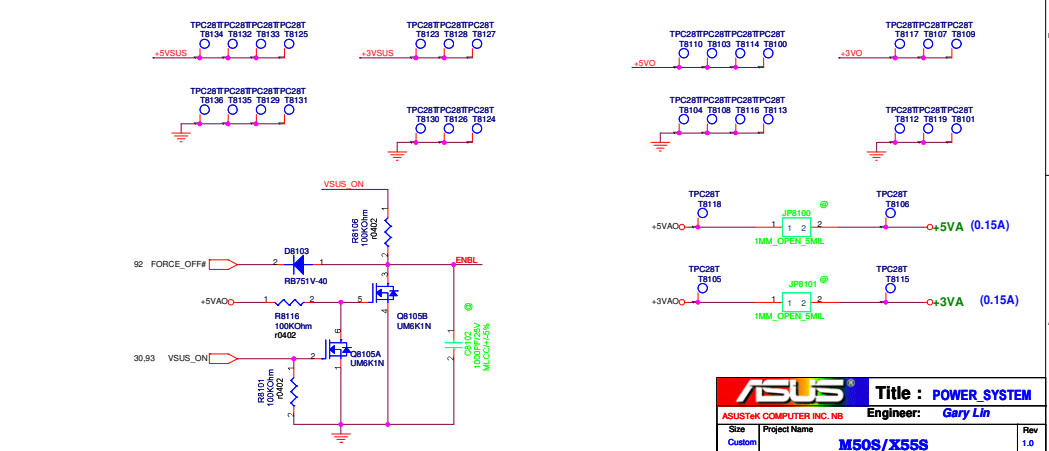
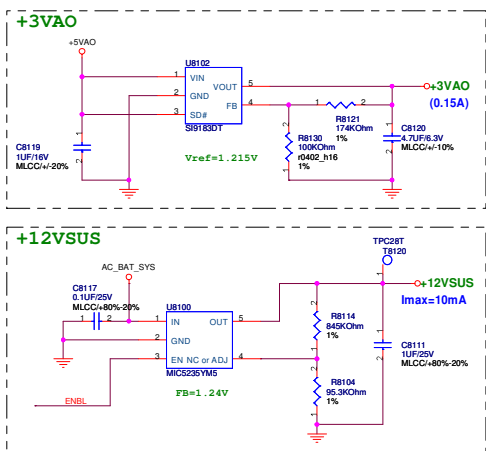
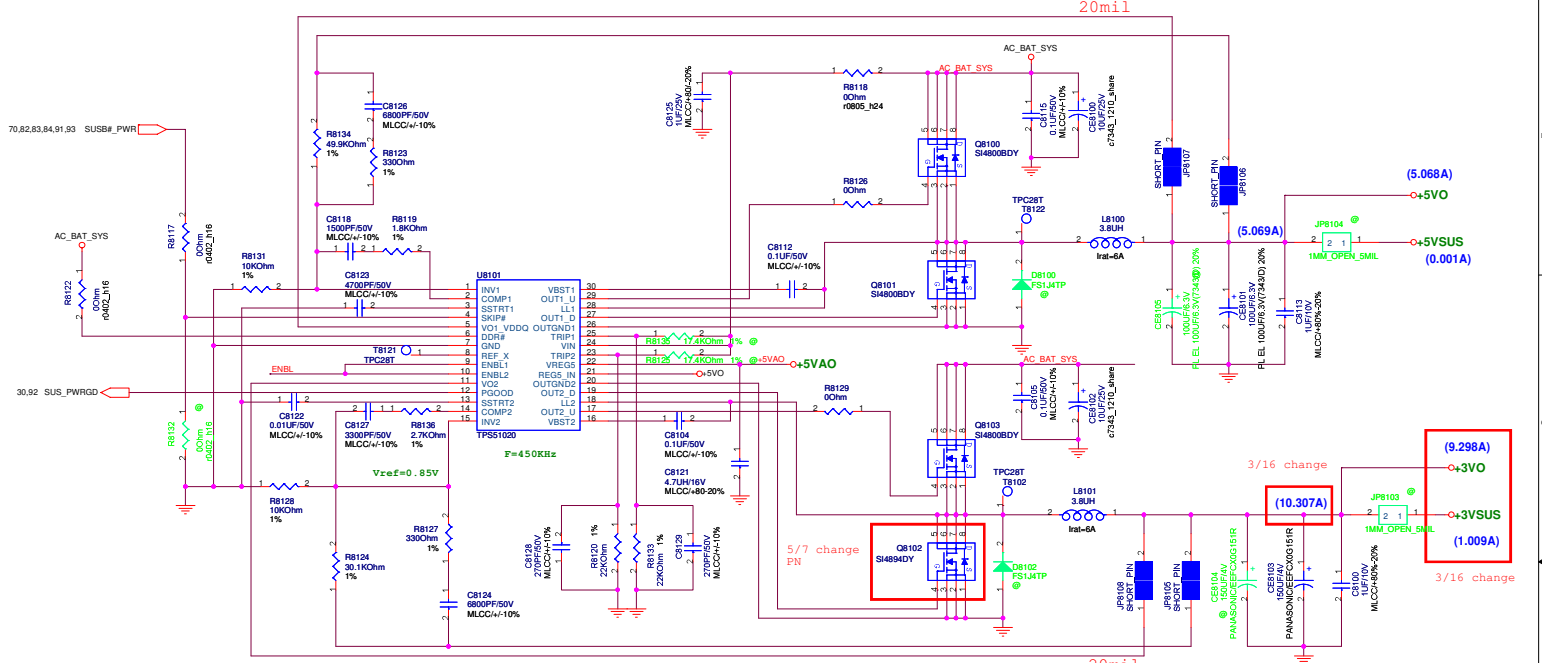

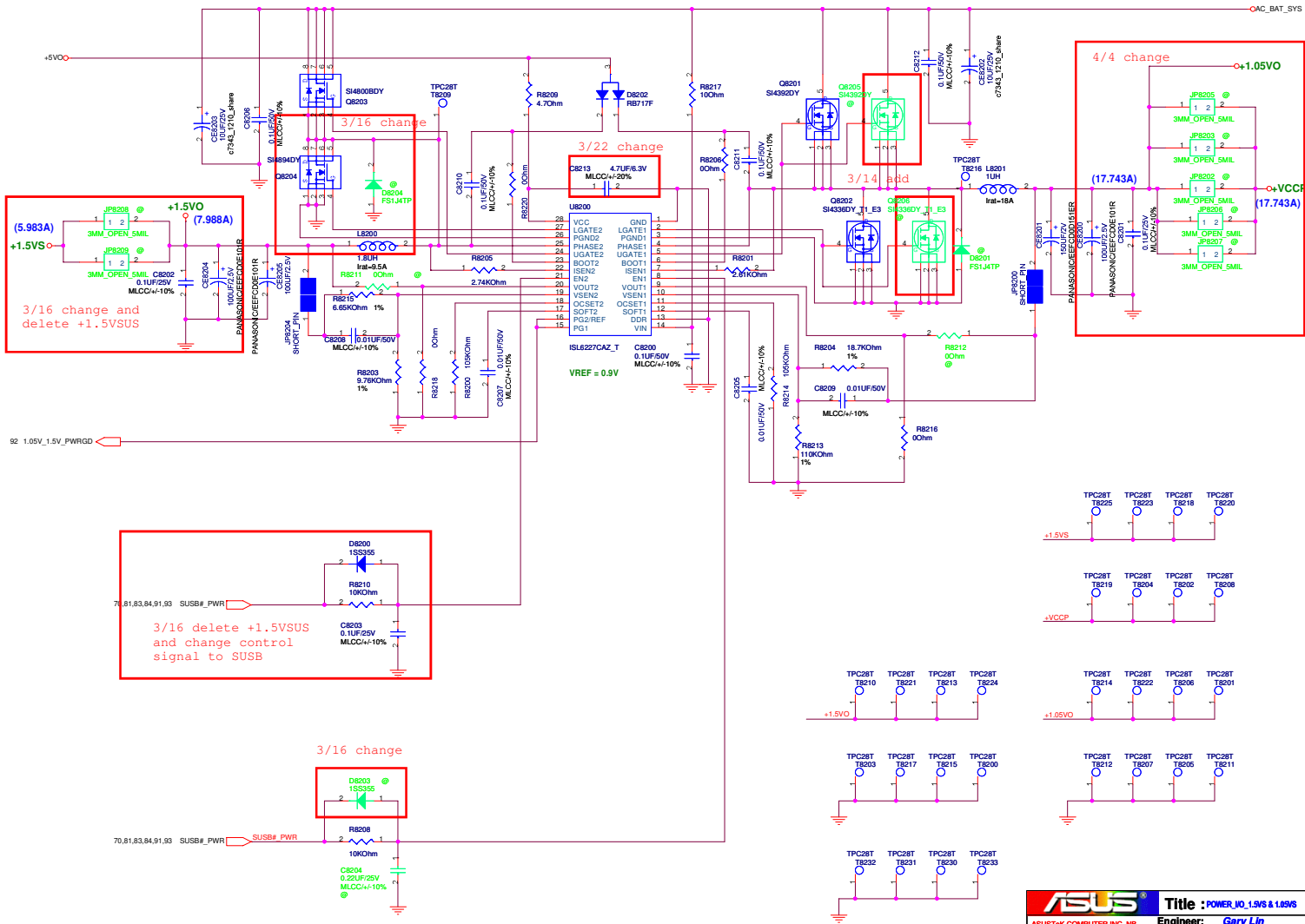

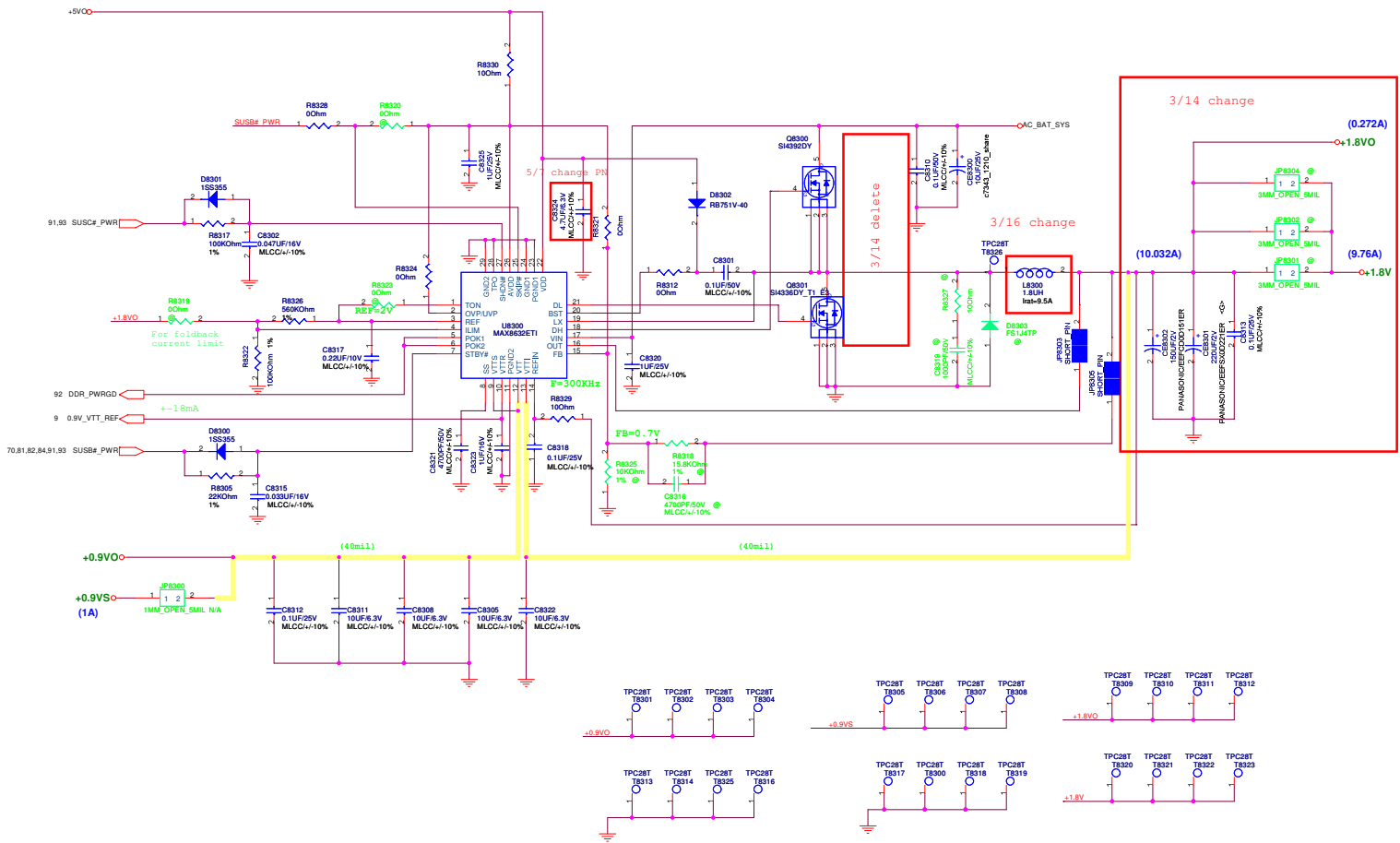

ASUS		Title : POWER_IO_DDR & VTT	
ASUSTEK COMPUTER INC. NB		Engineer: Gary Lin	
Size	Project Name	Rev	1.0
Custom	M50S/X55S	Date	Monday, September 03, 2007
		Sheet	83 of 89

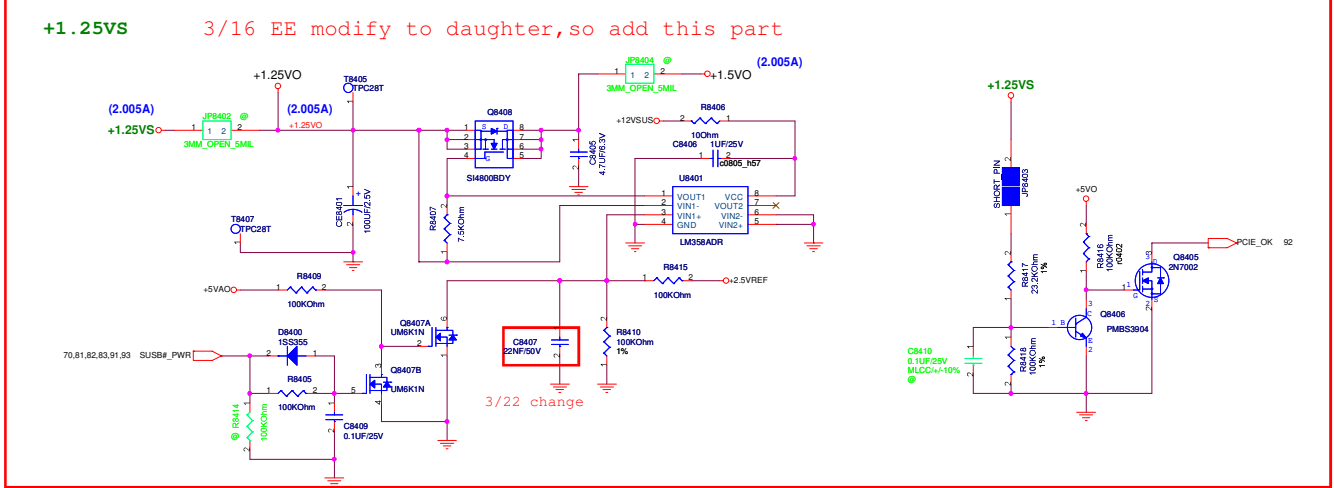

3/16 delete +2.5VSUS

3/14 EE modify to daughter,so delete this page

		Title : N/A	
ASUSTEK COMPUTER INC. NB		Engineer: Gary Lin	
Site	Project Name		Rev
Custom	M50S/X55S		1.0
Date: Monday, September 03, 2007		Sheet 05 of 05	

POWER PATH & BAT_LEARN

90 WATT

● AC_IN Threshold > 0.048Vms AD_DOCK_IN
 > 17.44V active
 Adapter (In/ma) = [0.075V/Rsense/Adm]/[VCLS.VREF]
 ResenseAdm=0.075ms
 VCLS=2.534V
 => In/ma=4.5A
 => Constant Power = 13.145 + 85.5W
 => RST to 200/257/15330K
 Charge Current Ichg = [0.075V/Rsense/CHG]/[VCTL3.VV]
 ResenseCHG=0.075ms
 VCTL3.VV => Ichg = 2.5A
 VCTL3.VV => Ichg = 1.4A
 Vbat = Cell1 [Vbat - (VCTL - 1.5V) / 9.52]
 VCTL = 1.58V
 => Vbat = 4.2V
 Mode pin: Vinode > 2.5V (96 to LDO pin) => 4 Cells
 2.0 Vinode > 1.8V (Booting) => 3 Cells
 0.8 Vinode (96 to DCIN) => Learning mode
 VICT < 0.8V or DCIN < 7V => Charger Disable
 Precharge current=150mA

3/6 change for 3S2P/3S3P only 4/4 deleted

3/16 change
 3/16 change colayout
 4/4 deleted by EE

4/4 deleted

4/17 DELETE BAT_S WITHOUT SHUTDOWN FUNCTION

AC_BAT_SYS_INV to Inverter connect,
 Power Issue =>Email (mail)
 Put JP8805 close to Q8800

MAX8725 LDO
 REF: 4.2235V

MAX8725 REF

MAX8725 LDO

MAX8725 LDO

MAX8725 LDO

MAX8725 LDO

MAX8725 LDO

MAX8725 LDO

MAX8725 LDO

MAX8725 LDO

MAX8725 LDO

MAX8725 LDO

MAX8725 LDO

MAX8725 LDO

MAX8725 LDO

MAX8725 LDO

MAX8725 LDO

MAX8725 LDO

MAX8725 LDO

MAX8725 LDO

MAX8725 LDO

MAX8725 LDO

MAX8725 LDO

MAX8725 LDO

MAX8725 LDO

MAX8725 LDO

MAX8725 LDO

MAX8725 LDO

MAX8725 LDO

MAX8725 LDO

MAX8725 LDO

MAX8725 LDO

MAX8725 LDO

MAX8725 LDO

MAX8725 LDO

MAX8725 LDO

MAX8725 LDO

MAX8725 LDO

MAX8725 LDO

MAX8725 LDO

MAX8725 LDO

MAX8725 LDO

MAX8725 LDO

MAX8725 LDO

MAX8725 LDO

MAX8725 LDO

MAX8725 LDO

MAX8725 LDO

MAX8725 LDO

MAX8725 LDO

MAX8725 LDO

MAX8725 LDO

MAX8725 LDO

MAX8725 LDO

MAX8725 LDO

MAX8725 LDO

MAX8725 LDO

MAX8725 LDO

MAX8725 LDO

MAX8725 LDO

MAX8725 LDO

MAX8725 LDO

MAX8725 LDO

MAX8725 LDO

MAX8725 LDO

MAX8725 LDO

MAX8725 LDO

MAX8725 LDO

MAX8725 LDO

MAX8725 LDO

MAX8725 LDO

MAX8725 LDO

MAX8725 LDO

MAX8725 LDO

MAX8725 LDO

MAX8725 LDO

MAX8725 LDO

MAX8725 LDO

MAX8725 LDO

MAX8725 LDO

MAX8725 LDO

MAX8725 LDO

MAX8725 LDO

MAX8725 LDO

MAX8725 LDO

MAX8725 LDO

MAX8725 LDO

MAX8725 LDO

MAX8725 LDO

MAX8725 LDO

MAX8725 LDO

MAX8725 LDO

MAX8725 LDO

MAX8725 LDO

MAX8725 LDO

MAX8725 LDO

MAX8725 LDO

MAX8725 LDO

MAX8725 LDO

MAX8725 LDO

MAX8725 LDO

MAX8725 LDO

MAX8725 LDO

MAX8725 LDO

MAX8725 LDO

MAX8725 LDO

MAX8725 LDO

MAX8725 LDO

MAX8725 LDO

MAX8725 LDO

MAX8725 LDO

MAX8725 LDO

MAX8725 LDO

MAX8725 LDO

MAX8725 LDO

MAX8725 LDO

MAX8725 LDO

MAX8725 LDO

MAX8725 LDO

MAX8725 LDO

MAX8725 LDO

MAX8725 LDO

MAX8725 LDO

MAX8725 LDO

MAX8725 LDO

MAX8725 LDO

MAX8725 LDO

MAX8725 LDO

MAX8725 LDO

MAX8725 LDO

MAX8725 LDO

MAX8725 LDO

MAX8725 LDO

MAX8725 LDO

MAX8725 LDO

MAX8725 LDO

MAX8725 LDO

MAX8725 LDO

MAX8725 LDO

MAX8725 LDO

MAX8725 LDO

MAX8725 LDO

MAX8725 LDO

MAX8725 LDO

MAX8725 LDO

MAX8725 LDO

MAX8725 LDO

MAX8725 LDO

MAX8725 LDO

MAX8725 LDO

MAX8725 LDO

MAX8725 LDO

MAX8725 LDO

MAX8725 LDO

MAX8725 LDO

MAX8725 LDO

MAX8725 LDO

MAX8725 LDO

MAX8725 LDO

MAX8725 LDO

MAX8725 LDO

MAX8725 LDO

MAX8725 LDO

MAX8725 LDO

MAX8725 LDO

MAX8725 LDO

MAX8725 LDO

MAX8725 LDO

MAX8725 LDO

MAX8725 LDO

MAX8725 LDO

MAX8725 LDO

MAX8725 LDO

MAX8725 LDO

MAX8725 LDO

MAX8725 LDO

MAX8725 LDO

MAX8725 LDO

MAX8725 LDO

MAX8725 LDO

MAX8725 LDO

MAX8725 LDO

MAX8725 LDO

MAX8725 LDO

MAX8725 LDO

MAX8725 LDO

MAX8725 LDO

MAX8725 LDO

MAX8725 LDO

MAX8725 LDO

MAX8725 LDO

MAX8725 LDO

MAX8725 LDO

MAX8725 LDO

MAX8725 LDO

MAX8725 LDO

MAX8725 LDO

MAX8725 LDO

MAX8725 LDO

MAX8725 LDO

MAX8725 LDO

MAX8725 LDO

MAX8725 LDO

MAX8725 LDO

MAX8725 LDO

MAX8725 LDO

MAX8725 LDO

MAX8725 LDO

MAX8725 LDO

MAX8725 LDO

MAX8725 LDO

MAX8725 LDO

MAX8725 LDO

MAX8725 LDO

MAX8725 LDO

MAX8725 LDO

MAX8725 LDO

MAX8725 LDO

MAX8725 LDO

MAX8725 LDO

MAX8725 LDO

MAX8725 LDO

MAX8725 LDO

MAX8725 LDO

MAX8725 LDO

MAX8725 LDO

MAX8725 LDO

MAX8725 LDO

MAX8725 LDO

MAX8725 LDO

MAX8725 LDO

MAX8725 LDO

MAX8725 LDO

MAX8725 LDO

MAX8725 LDO

MAX8725 LDO

MAX8725 LDO

MAX8725 LDO

MAX8725 LDO

MAX8725 LDO

MAX8725 LDO

MAX8725 LDO

MAX8725 LDO

MAX8725 LDO

MAX8725 LDO

MAX8725 LDO

MAX8725 LDO

MAX8725 LDO

MAX8725 LDO

MAX8725 LDO

MAX8725 LDO

MAX8725 LDO

MAX8725 LDO

BATTERY IN DETECT

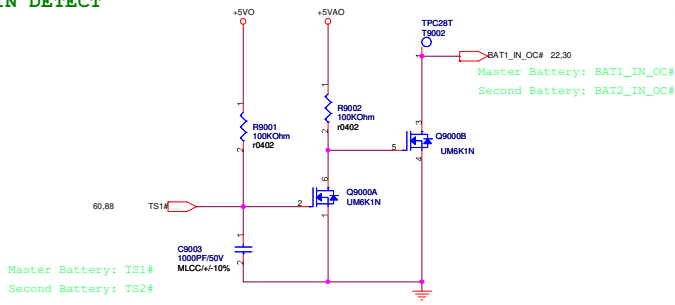

ADAPTER IN DETECT

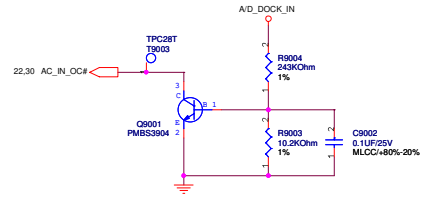

+2.5VREF

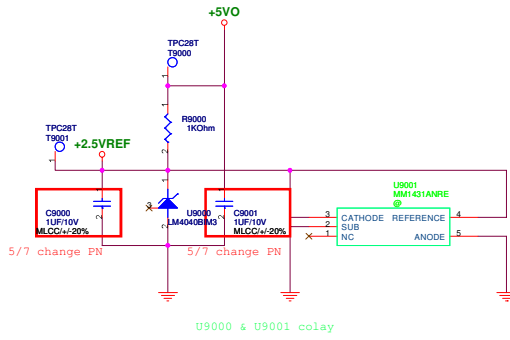

ASUS		Title : POWER_DETECT	
ASUSTEK COMPUTER INC. NB		Engineer: Gary Lin	
Size	Project Name	Rev	
Custom	M50S/X55S	1.0	
Date: Monday, September 03, 2007	Sheet	90	of 95

SUSB#_PWR POWER

3/16 delete +1.5VS from load switch

3/14 delete +VRAM

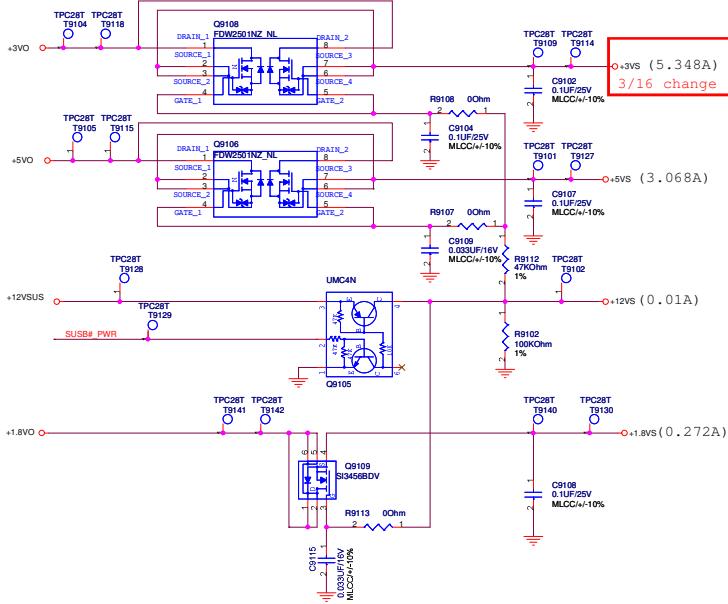

SUSC#_PWR POWER

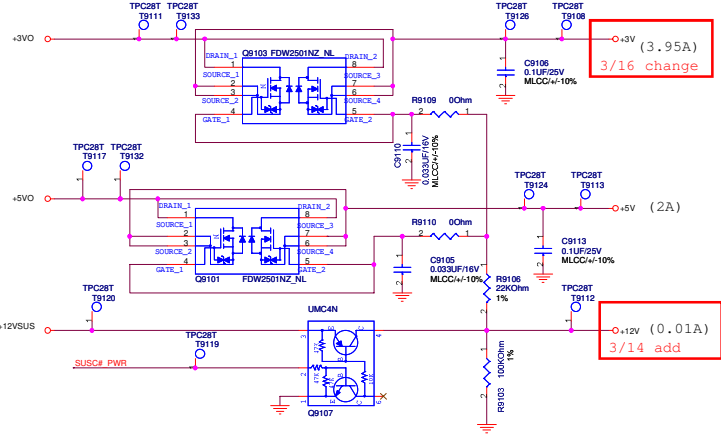

3/16 delete +1.5V

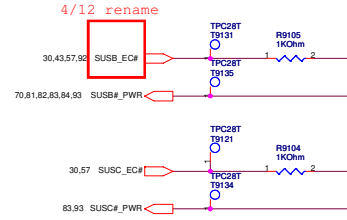

POWER GOOD DETECTOR

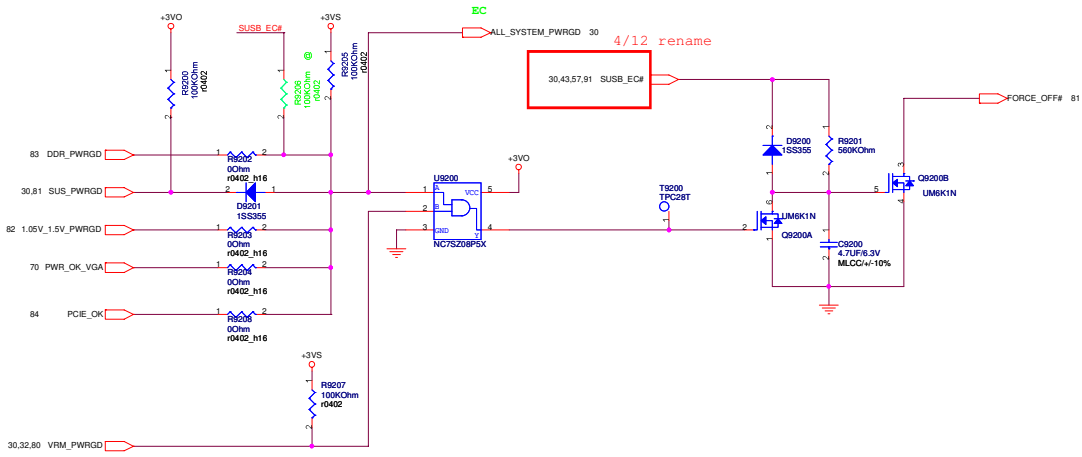

ASUS		Title : POWER_PROTECT	
ASUSTEK COMPUTER INC. NB		Engineer: Gary Lin	
Size	Project Name		Rev
Custom	M50S/X55S		1.0
Date: Monday, September 03, 2007	Sheet	82	of 88

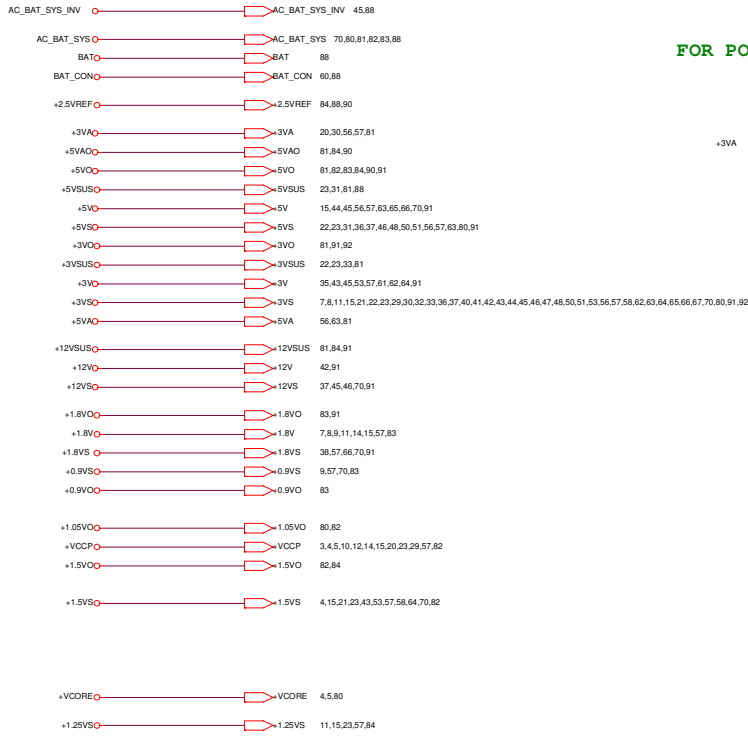

FOR POWER TEST

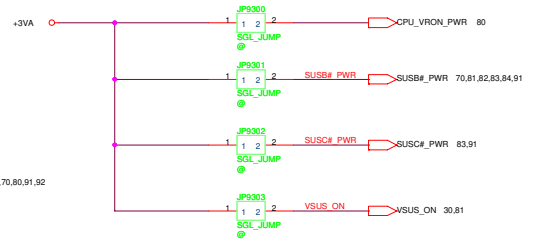

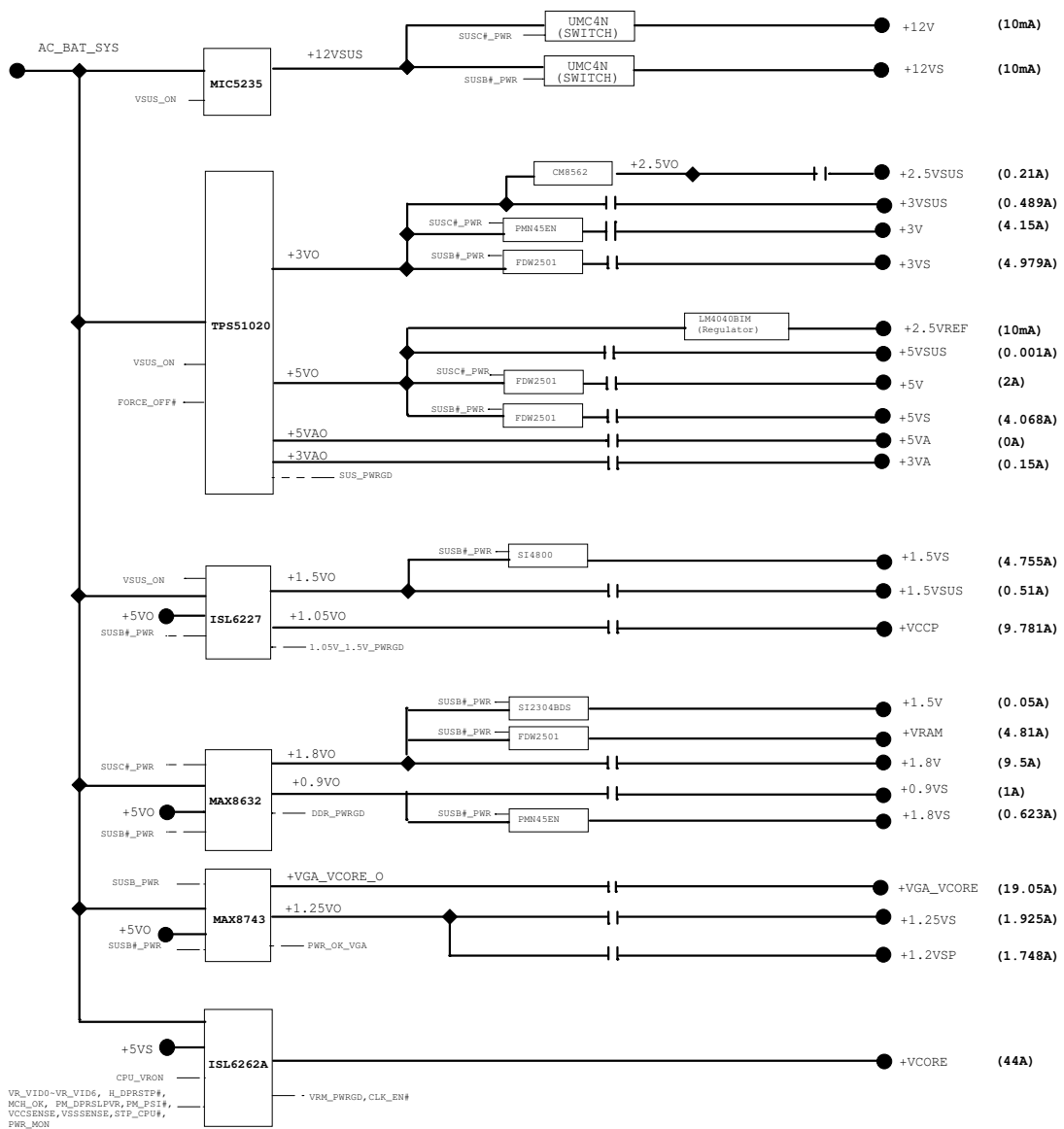

VR_VID0-VR_VID6, H_DPRSTP#,
MCH_OK, PM_DPRS1PVR, PM_PSI#,
VCCSENSE, VSSSENSE, STP_CPU#,
PWR_MON

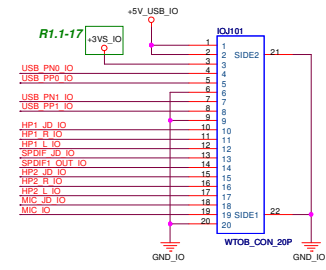

R1.1-31

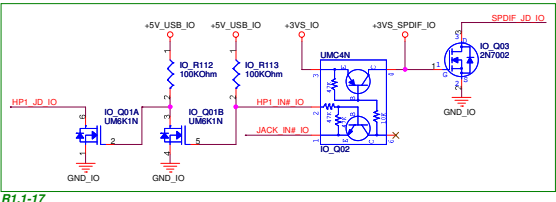
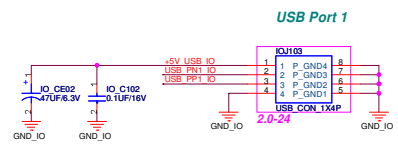
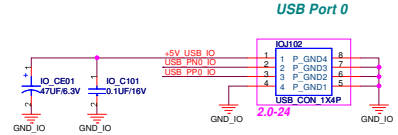

R1.1-17

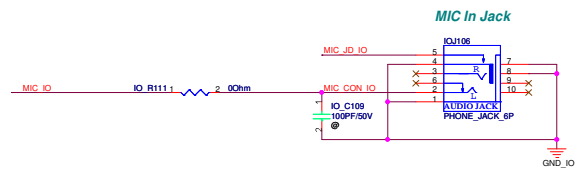
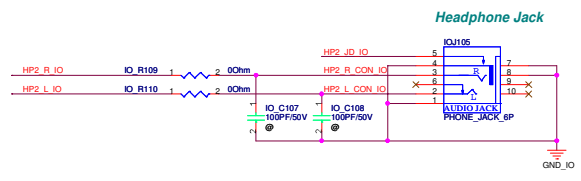
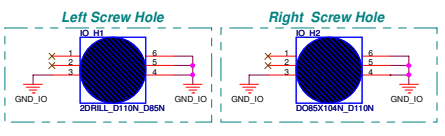
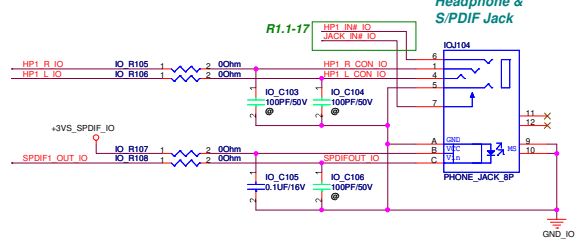

		Title : USB & Audio Jack	
		ASUSTek COMPUTER INC. NBI	Engineer: Wenchi Shen
Size	Project Name	Rev	
Custom	M50S/X55S	2.0	
Date: Monday, September 03, 2007	Sheet: 85	of 88	

Rev	Date	Description
R1.0		First Release!
R1.1 Green Block		<p>** Merge IO board into main board PCB. Page 95.</p> <p>01.Remove VR_VID[6:0] testing series 0 Ohm. Page 4.</p> <p>02.Change 6pcs +VCCORE capacitors to No-Stuff for cost down. Page 5.</p> <p>03.Change 3pcs +0.9VS capacitors to No-Stuff for cost down. Page 9.</p> <p>04.Change N1Sv USB port to follow N2Sv, and modify USB_OC#. Page 21,43,45.</p> <p>05.PM Request: Change Bluetooth LED tp E-Mail LED. Page 22,56.</p> <p>06.Follow Intel to change C2304 to 1uF/16V(XR). Page 23.</p> <p>07.Follow R1E to change R2904 to 270ohm. Page 29.</p> <p>08.Follow IT8752/8512 EC Common Hardware Pin Assignment v0.005, change GPE7 to INSTANT_ON# and GPG0 to PM_THERM#. Page 30.</p> <p>09.PM REquest: Remove USB port charger function. Page 30,65.</p> <p>10.PM change WWAN LED to touch-pad lock LED. Page 30,56.</p> <p>11.Change IR to 36KHz to meet Vista remote control Min. range requirement. Page 31.</p> <p>12.Remove testing 2nd CIR design. Page 31.</p> <p>13.Change X3301 to 49S type for cost down. Page 33.</p> <p>14.LAN chip version change. Page 33.</p> <p>15.Audio codec chip change version. Page 36.</p> <p>16.N1Sv/X55 will not supprot 3G function. Page 36,67.</p> <p>17.Add S/PDIF & HDMI jack detect by Realtek sugesstion. Page 36,65,70,95.</p> <p>18.Modify audio de-pop circuit. Page 36,37.</p> <p>19.Modify LVDS power sequence failed bug. Page 45.</p> <p>20.Modify LCD abnormal display bug due to LVDS pair mismatch. Page 45,70.</p> <p>21.Remove HDIV support function. Page 47,70.</p> <p>22.Remove HDMI EMI filter design. Page 48.</p> <p>23.X55 need two pwer LEDs. Page 56.</p> <p>24.PM change WLAN LED to RF LED. Page 56,63.</p> <p>25.Bluetooth pin define error. Page 61.</p> <p>26.Remove co-layout sequence logic control circuit. Page 68.</p> <p>27.ME change parts: J3401,J5102,J6002,J6501. Page 34,51,60,65.</p> <p>28.EMI modification. Page 34,36,65.</p> <p>29.Crystal accuracy fine-tune. Page</p> <p>30.USB droop test fail. Page 65.</p> <p>31.Remove IO board USB common choke design. Page 95.</p> <p>32.Speaker fine-tune. Page 37.</p> <p>33.Cost down for 4-wire PWM fan. Page 50.</p> <p>34.Cost down: Change RB717F to BAT54AW. Page 37,45,48,56.</p>
R2.0 Pink Block		<p>01.Change +1.25VS_MPLL, +1.25VS_PEGPLL & +1.8V_SM_CK PLL design. Page 15.</p> <p>02.Add CMOS crack protection circuit. Page 22.</p> <p>03.Reserve C2337 (10UF/16V) for +5VREF_ICH. Page 23.</p> <p>04.Change ICS9LPR363 version from D to E for SATA clock jitter improve. Page 29.</p> <p>05.With EMI's confirmation, replace R2901, R2905, R2906 with short-pad JP2901, JP2902, JP2903. Page 29.</p> <p>06.With EC's confirmation, change ITE8752 P/N to 06G042016011. Page 30.</p> <p>07.With EMI's confirmation, replace R3001 with short-pad JP3002. Page 30.</p> <p>08.With EMI RD's confirmation, remove reserved LAN common choke circuit. Page 34.</p> <p>09.With EMI's confirmation, change R3612, R3614, R3615, R3616, R3622, R3624, R3626 to short-pad JP3601-JP3607. And change R3611, R3613, R3623, R3625 to No-Stuff. Page 36.</p> <p>10.Post wave sounds abnormal when audio amplifier use GMT G1431. Change C3706 to 0.33UF to shorten audio amplifier start-up time. Page 37.</p>

Rev	Date	Description
		<p>11.For cost down, change CE3701-CE3704 to 47UF. And after EA test, these can pass Vista audio criteria. Page 37.</p> <p>12.With EMI's confirmation, remove reserved 1394 common choke circuit. Page 41.</p> <p>13.With EMI's confirmation, remove reserved NewCard USB common choke circuit. Page 43.</p> <p>14.Add NewCard debug card co-layout circuit. Page 44.</p> <p>15.EMI modification: change reserved common choke circuit from USB port to internal camera port. Page 45.</p> <p>16.With EMI's confirmation, replace RX4603, RX4604 with JP4601, JP4602. Page 46.</p> <p>17.HDMI jack detection modification. Page 48,70.</p> <p>18.With EMI's confirmation, replace RX4809, RX4810 with JP4801, JP4802. Page 48.</p> <p>19.Change PWM FAN capacitors to 10UF. Page 50.</p> <p>20.Modify X55S power LED design. Page 56.</p> <p>21.Modify DC_IN bead for 120W design. Page 60.</p> <p>22.With EMI's confirmation, remove reserved e-SATA/USB combo port USB common choke circuit. Page 66.</p> <p>23.Reserve R8023 for shortage issue of ISL6262A. Page 80.</p> <p>24.QTR USB plug test failed, change USB connector. Page 95.</p>

		Title : Revision History	
ASUSTek COMPUTER INC. NBI		Engineer: John Hung	
Site	Project Name	Rev	
Custom	M50S/X55S	1.0	
Date: Wednesday, September 05, 2007		Sheet	98 of 98