

Z94 SCHEMATICS : MAIN BOARD REV 1.1

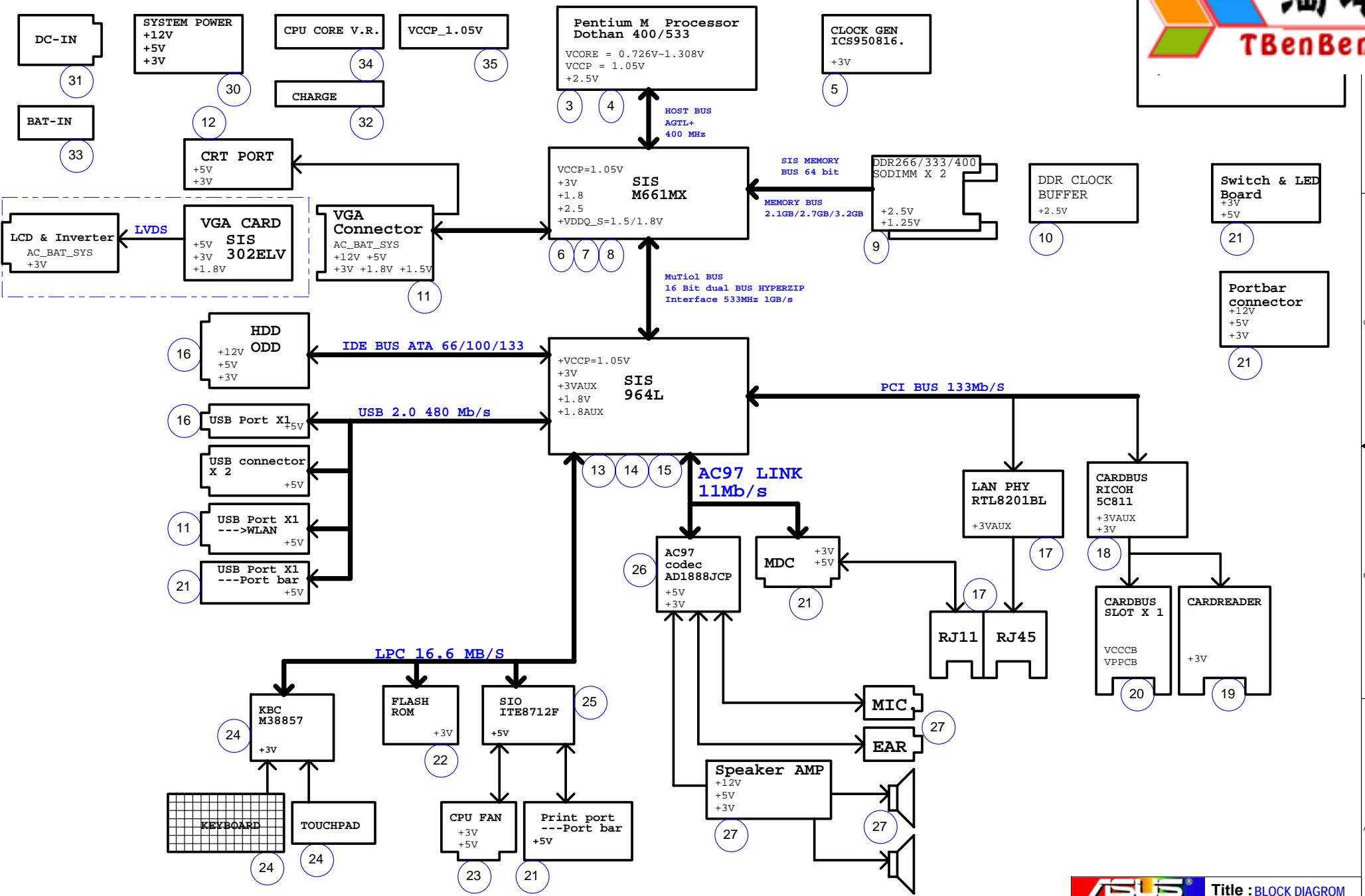

- P.01--INDEX (THIS PAGE)
- P.02--BLOCK DIAGRAM
- P.03--Pentium-M SOCKET479 - 1
- P.04--Pentium-M SOCKET479 - 2
- P.05--CLOCK GEN ICS950816
- P.06--SISM661MX (1) HOST/AGP
- P.07--SISM661MX (2) DDR/VGA/ZIP
- P.08--SISM661MX (3) PWR
- P.09--DDR Memory DIMM
- P.10--DDR Bypass & Driver
- P.11--VGA_Connector
- P.12--CRT Connector
- P.13--SIS964L - 1 PCI/ZIP/IDE
- P.14--SIS964L - 2 LPC/GPIO/AC97
- P.15--SIS964L - 3 USB/PWR
- P.16--HDD & CDROM CONN/USB
- P.17--LAN_RTL8201BL
- P.18--CardBus (1)
- P.19--CardBus (2)
- P.20--Debug Port & Hole & EMI
- P.21--Switch & MDC
- P.22--PortBar & FWH
- P.23--FAN controller
- P.24--KBC_KB38857
- P.25--Super I/O
- P.26--Audio Codec
- P.27--Audio AMP/JACK
- P.28--Power Sequence
- P.29--2.5V/1.8V/1.5V/1.25V
- P.30--SYSTEM_3V/5V
- P.31--BATLOW/SD#/DCIN
- P.32--CHARGER
- P.33--PIC16C54/BAT_IN
- P.34--Vcore
- P.35--VCCP_1.05V
- P.36--GPIO LIST
- P.37--POWER FLOW
- P.38--History





CPU Pin A1 need to be enlarged(M)

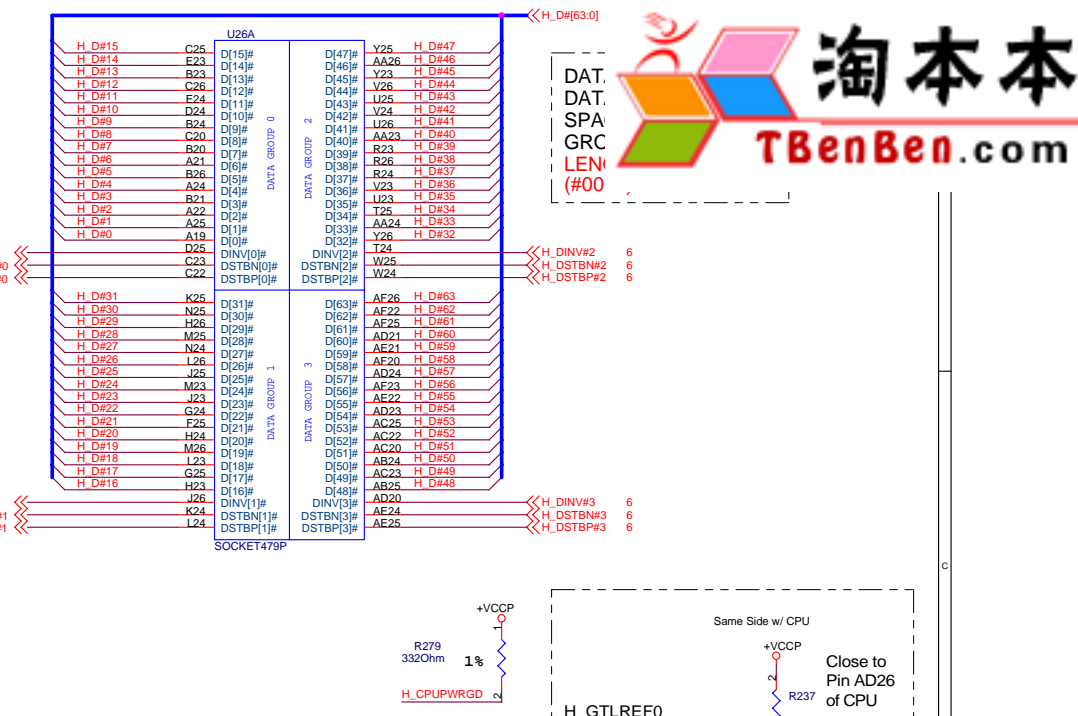
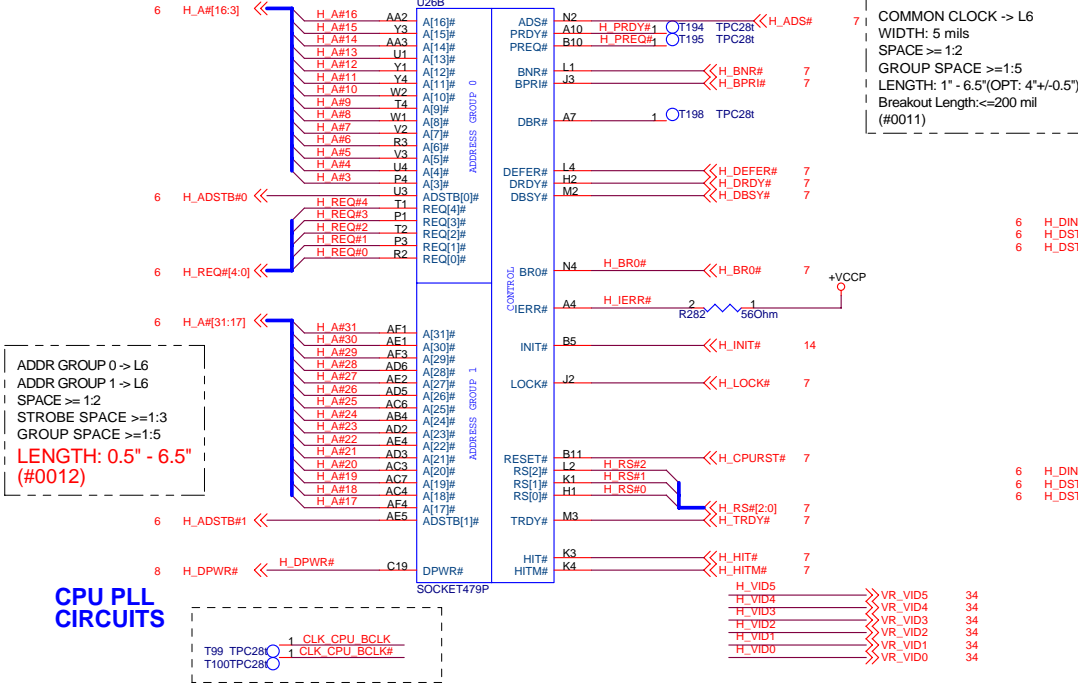

ADDR GROUP 0 > L6
 ADDR GROUP 1 > L6
 SPACE >= 1.2
 STROBE SPACE >=1.3
 GROUP SPACE >=1.5
 LENGTH: 0.5" - 6.5" (#0012)

CPU PLL CIRCUITS

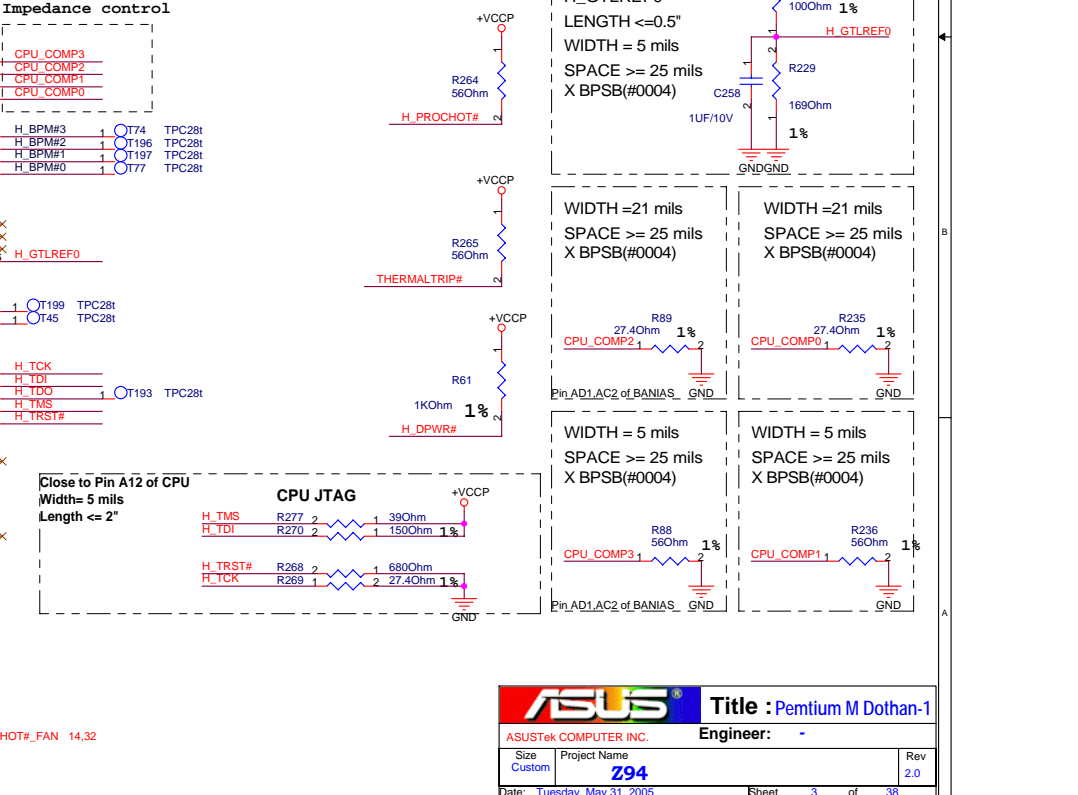
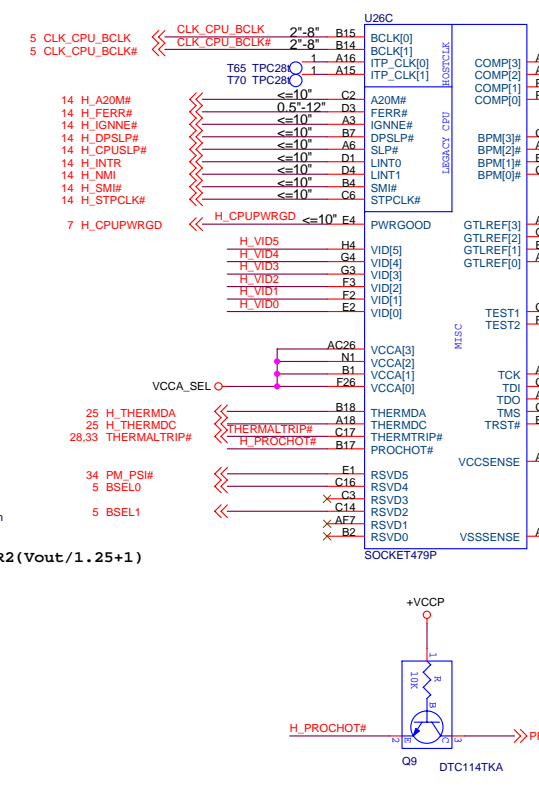
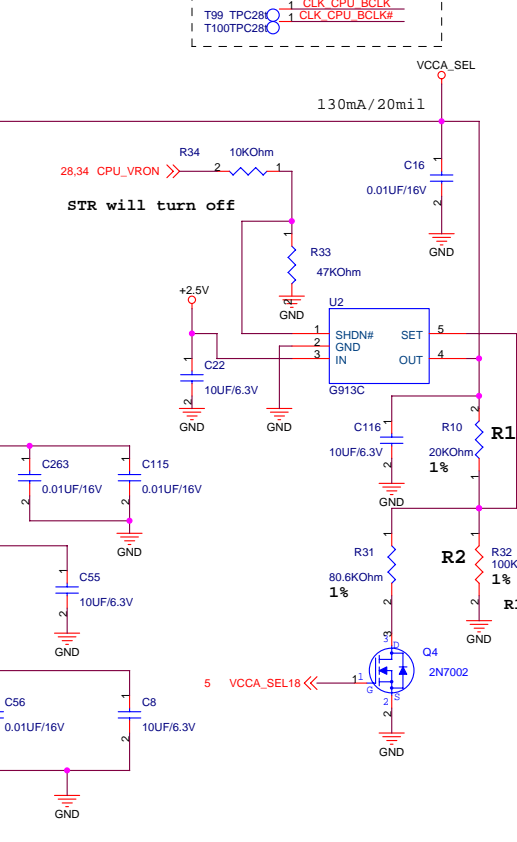

HFM(1.6GHz-2.13GHz): 0.726V - 1.308V(+/- 1.5%)
 1.308V C0: 23.1 A
 LFM(800MHz): C3: 8.9A
 0.988V C4: 3.7A

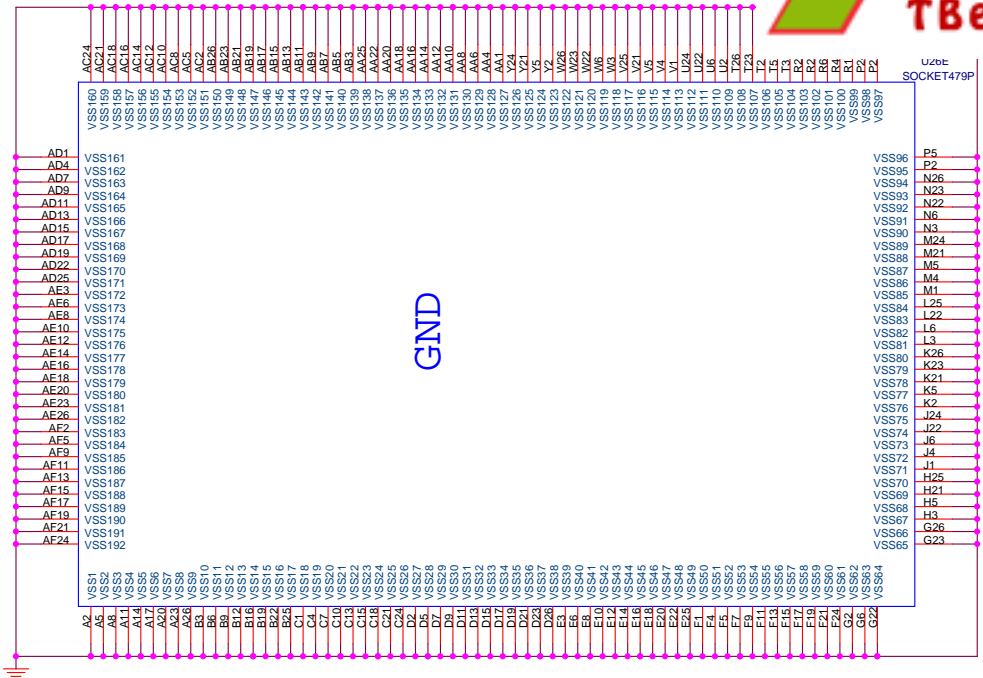
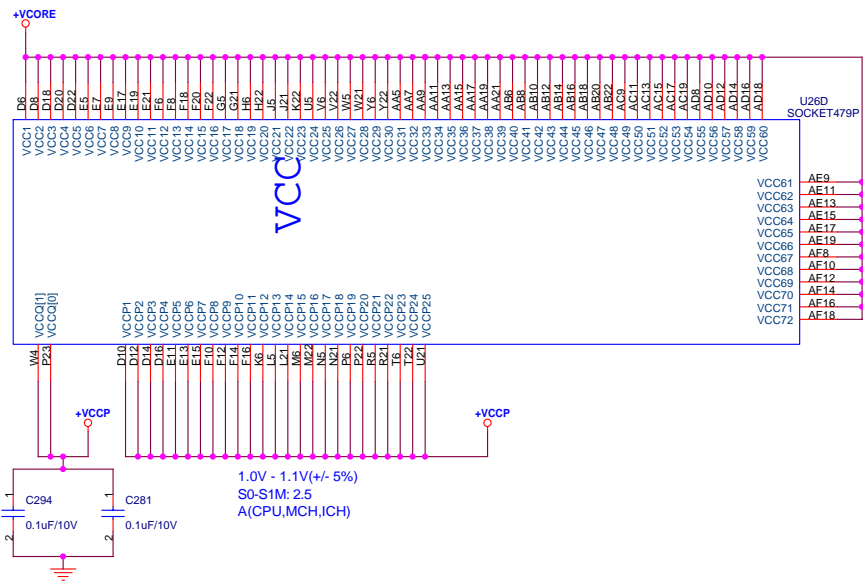

CPU VCORE Decoupling Capacitor

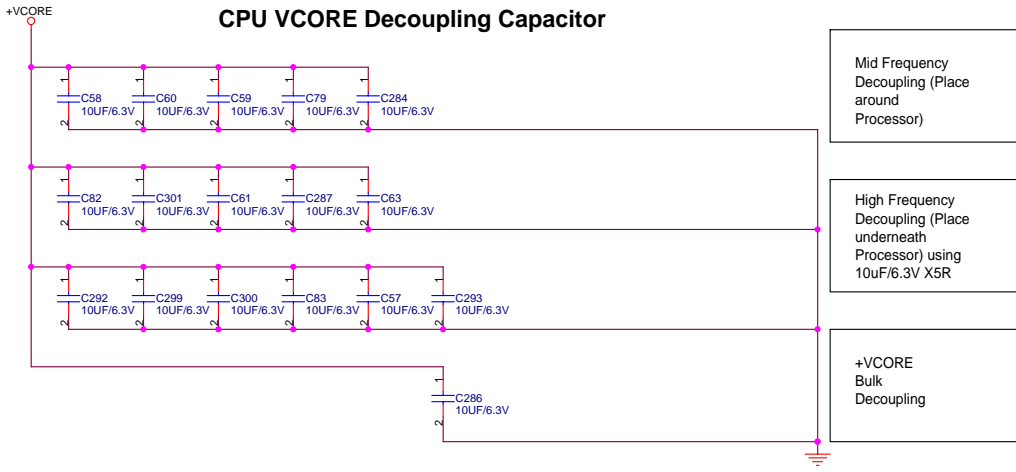

- Mid Frequency Decoupling (Place around Processor)
- High Frequency Decoupling (Place underneath Processor) using 10uF/6.3V X5R
- +VCCORE Bulk Decoupling

M3N : Four 200 uF are located in IMVP4
 A3N : Delete 10uF/6.3V from 35pcs to 17pcs

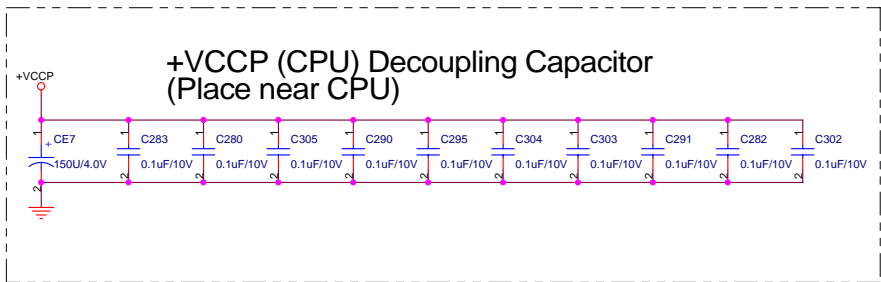

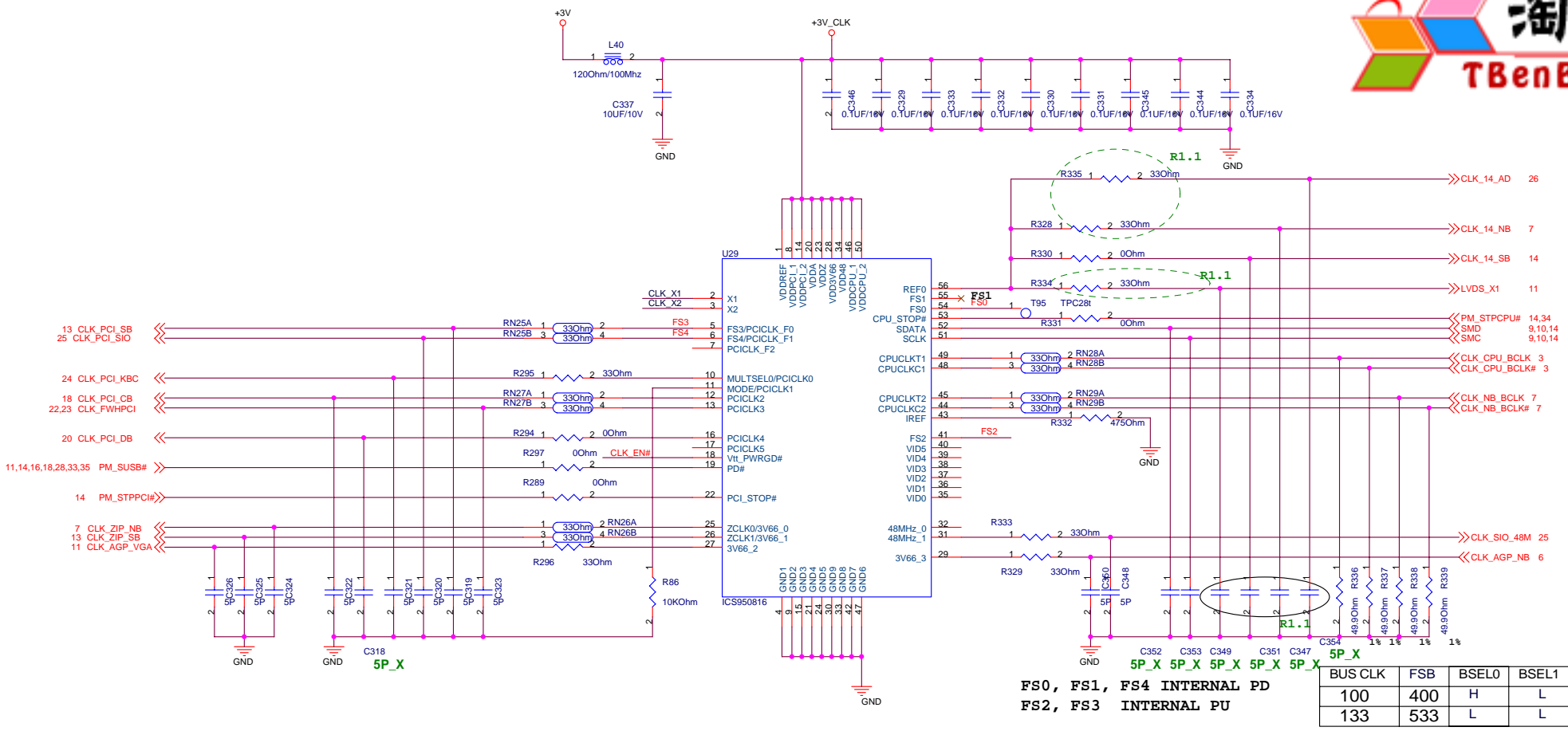

FS0, FS1, FS4 INTERNAL PD
FS2, FS3 INTERNAL PU

BUS CLK	FSB	BSEL0	BSEL1
100	400	H	L
133	533	L	L

FS4	FS3	FS2	FS1	FS0	CPU CLK	AGP CLK	PCI CLK
L	L	H	L	L	100	66.67	33.33
L	H	L	L	L	133	66.67	33.33

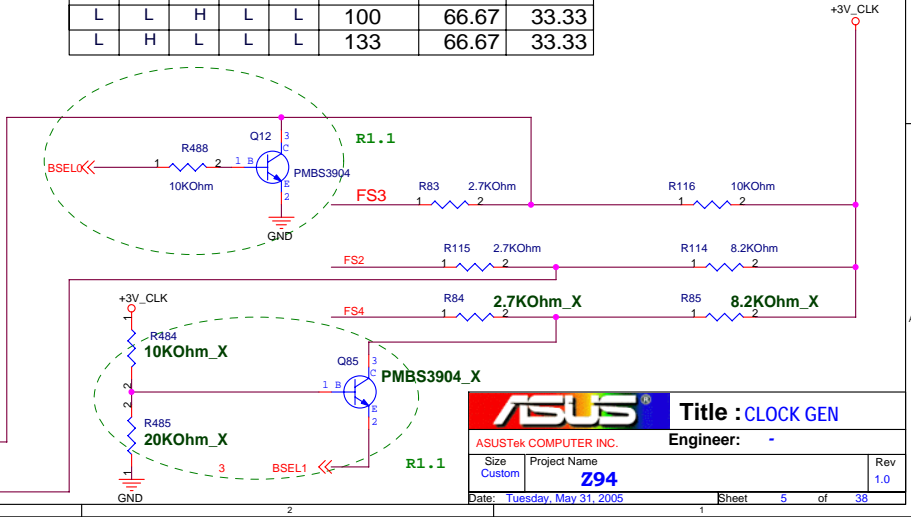
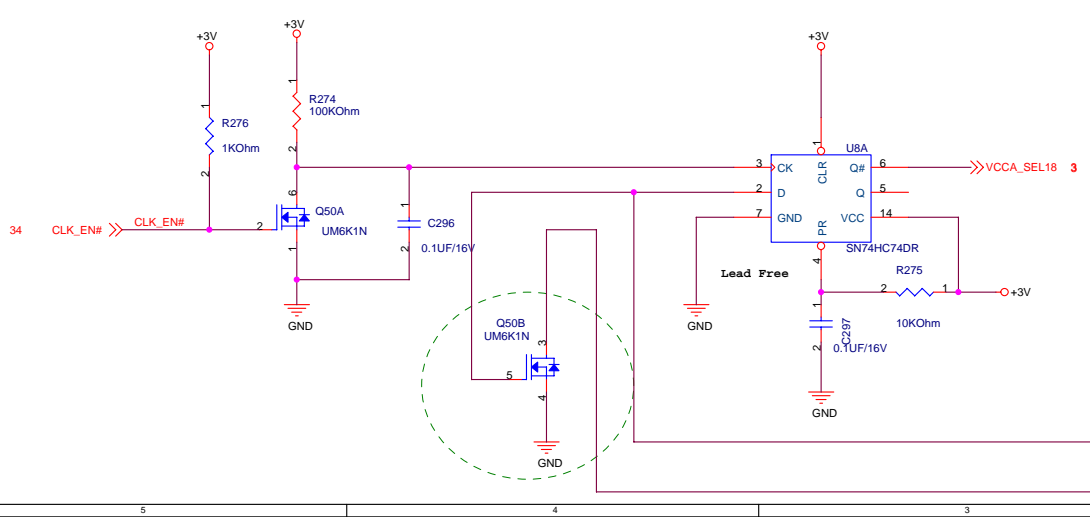



AGP_8XDET#	AGP_BUS	WGA_BUS
LO	HI	HI

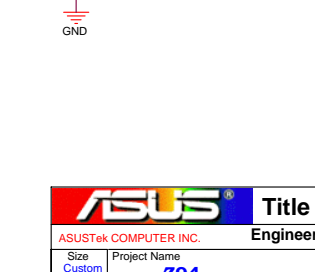
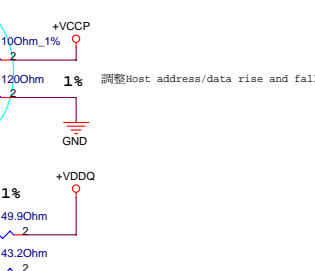
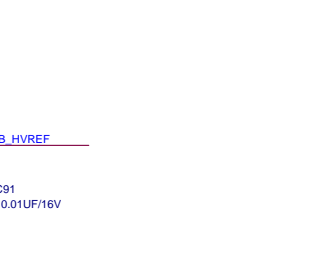
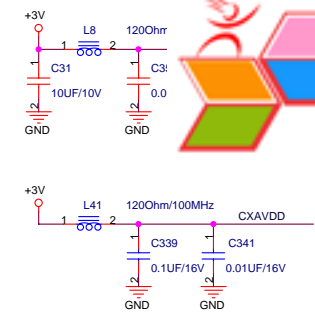
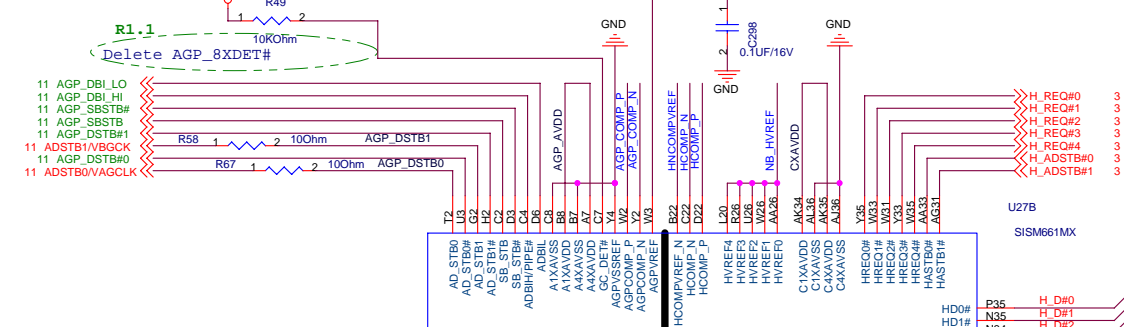

AGP

HOST

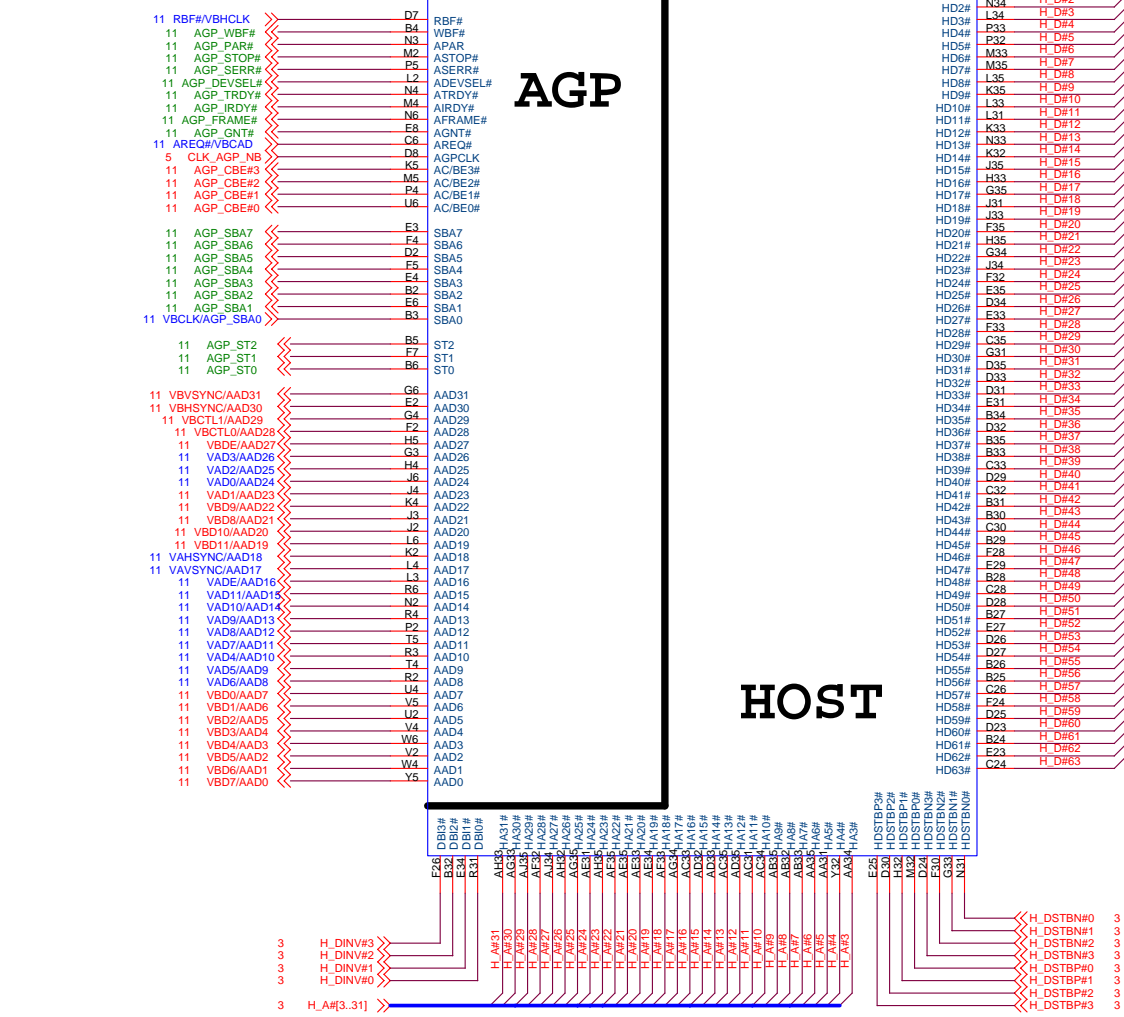

When system power ready will pass to CPU

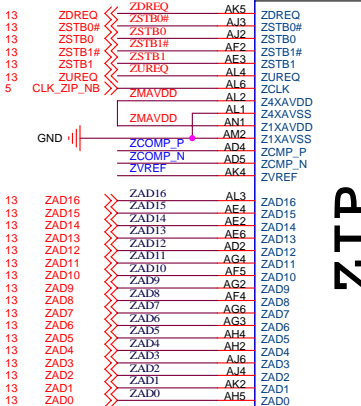
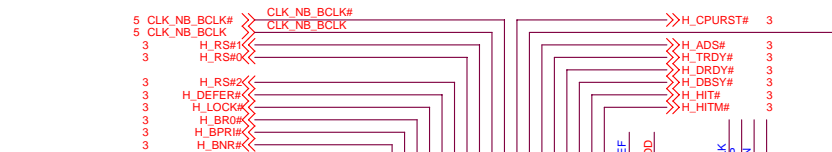

CPU IF

ZIP

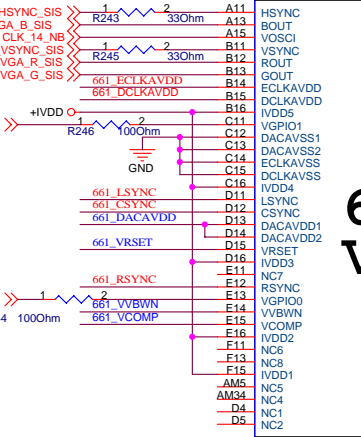

DDR

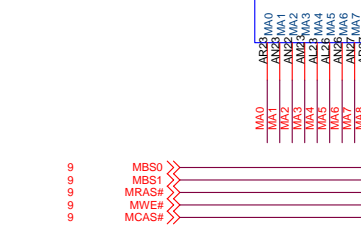

661 VGA

MD63	MD63
MD62	MD62
MD61	MD61
MD60	MD60
MD59	MD59
MD58	MD58
MD57	MD57
MD56	MD56
MD55	MD55
MD54	MD54
MD53	MD53
MD52	MD52
MD51	MD51
MD50	MD50
MD49	MD49
MD48	MD48
MD47	MD47
MD46	MD46
MD45	MD45
MD44	MD44
MD43	MD43
MD42	MD42
MD41	MD41
MD40	MD40
MD39	MD39
MD38	MD38
MD37	MD37
MD36	MD36
MD35	MD35
MD34	MD34
MD33	MD33
MD32	MD32
MD31	MD31
MD30	MD30
MD29	MD29
MD28	MD28
MD27	MD27
MD26	MD26
MD25	MD25
MD24	MD24
MD23	MD23
MD22	MD22
MD21	MD21
MD20	MD20
MD19	MD19
MD18	MD18
MD17	MD17
MD16	MD16
MD15	MD15
MD14	MD14
MD13	MD13
MD12	MD12
MD11	MD11
MD10	MD10
MD9	MD9
MD8	MD8
MD7	MD7
MD6	MD6
MD5	MD5
MD4	MD4
MD3	MD3
MD2	MD2
MD1	MD1
MD0	MD0
AN4	AN4
AN3	AN3
AN2	AN2
AN1	AN1
AN0	AN0
AM9	AM9
AM8	AM8
AM7	AM7
AM6	AM6
AM5	AM5
AM4	AM4
AM3	AM3
AM2	AM2
AM1	AM1
AM0	AM0
AP8	AP8
AP7	AP7
AP6	AP6
AP5	AP5
AP4	AP4
AP3	AP3
AP2	AP2
AP1	AP1
AP0	AP0
AP9	AP9
AP10	AP10
AP11	AP11
AP12	AP12
AP13	AP13
AP14	AP14
AP15	AP15
AP16	AP16
AP17	AP17
AP18	AP18
AP19	AP19
AP20	AP20
AP21	AP21
AP22	AP22
AP23	AP23
AP24	AP24
AP25	AP25
AP26	AP26
AP27	AP27
AP28	AP28
AP29	AP29
AP30	AP30
AP31	AP31
AP32	AP32
AP33	AP33
AP34	AP34
AP35	AP35
AP36	AP36
AP37	AP37
AP38	AP38
AP39	AP39
AP40	AP40
AP41	AP41
AP42	AP42
AP43	AP43
AP44	AP44
AP45	AP45
AP46	AP46
AP47	AP47
AP48	AP48
AP49	AP49
AP50	AP50
AP51	AP51
AP52	AP52
AP53	AP53
AP54	AP54
AP55	AP55
AP56	AP56
AP57	AP57
AP58	AP58
AP59	AP59
AP60	AP60
AP61	AP61
AP62	AP62
AP63	AP63
AP64	AP64
AP65	AP65
AP66	AP66
AP67	AP67
AP68	AP68
AP69	AP69
AP70	AP70
AP71	AP71
AP72	AP72
AP73	AP73
AP74	AP74
AP75	AP75
AP76	AP76
AP77	AP77
AP78	AP78
AP79	AP79
AP80	AP80
AP81	AP81
AP82	AP82
AP83	AP83
AP84	AP84
AP85	AP85
AP86	AP86
AP87	AP87
AP88	AP88
AP89	AP89
AP90	AP90
AP91	AP91
AP92	AP92
AP93	AP93
AP94	AP94
AP95	AP95
AP96	AP96
AP97	AP97
AP98	AP98
AP99	AP99
AP100	AP100

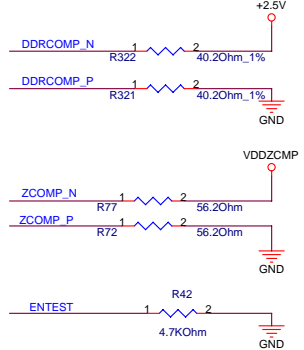
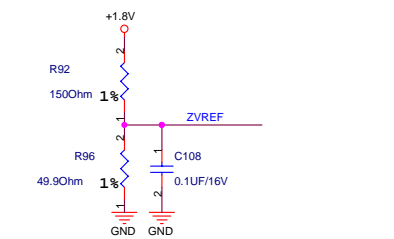
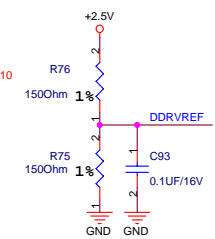
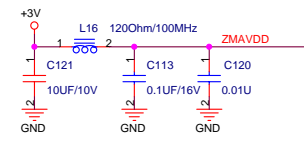
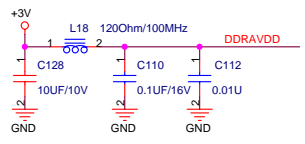
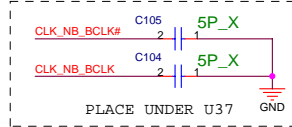
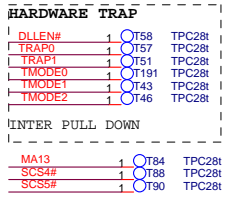
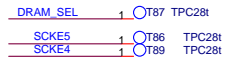
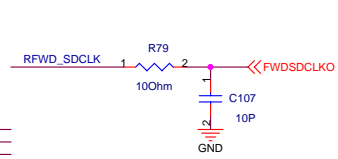
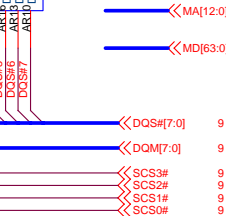

FOR SIS661 ONLY

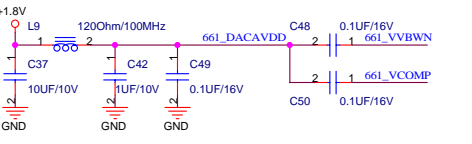
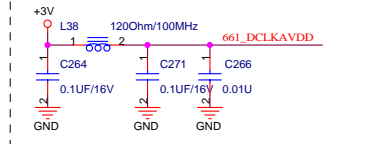

Function	Enable	Disable
RSync	VGA	1 0
LSync	TBD	0 0
CSync	TBD	0 0

ASUS Title : SIS661MX_DDR/VGA
 ASUSTek COMPUTER INC. Engineer: _____
 Size: Custom Project Name: Z94
 Date: Tuesday, May 31, 2005 Sheet 7 of 38 Rev 2.0

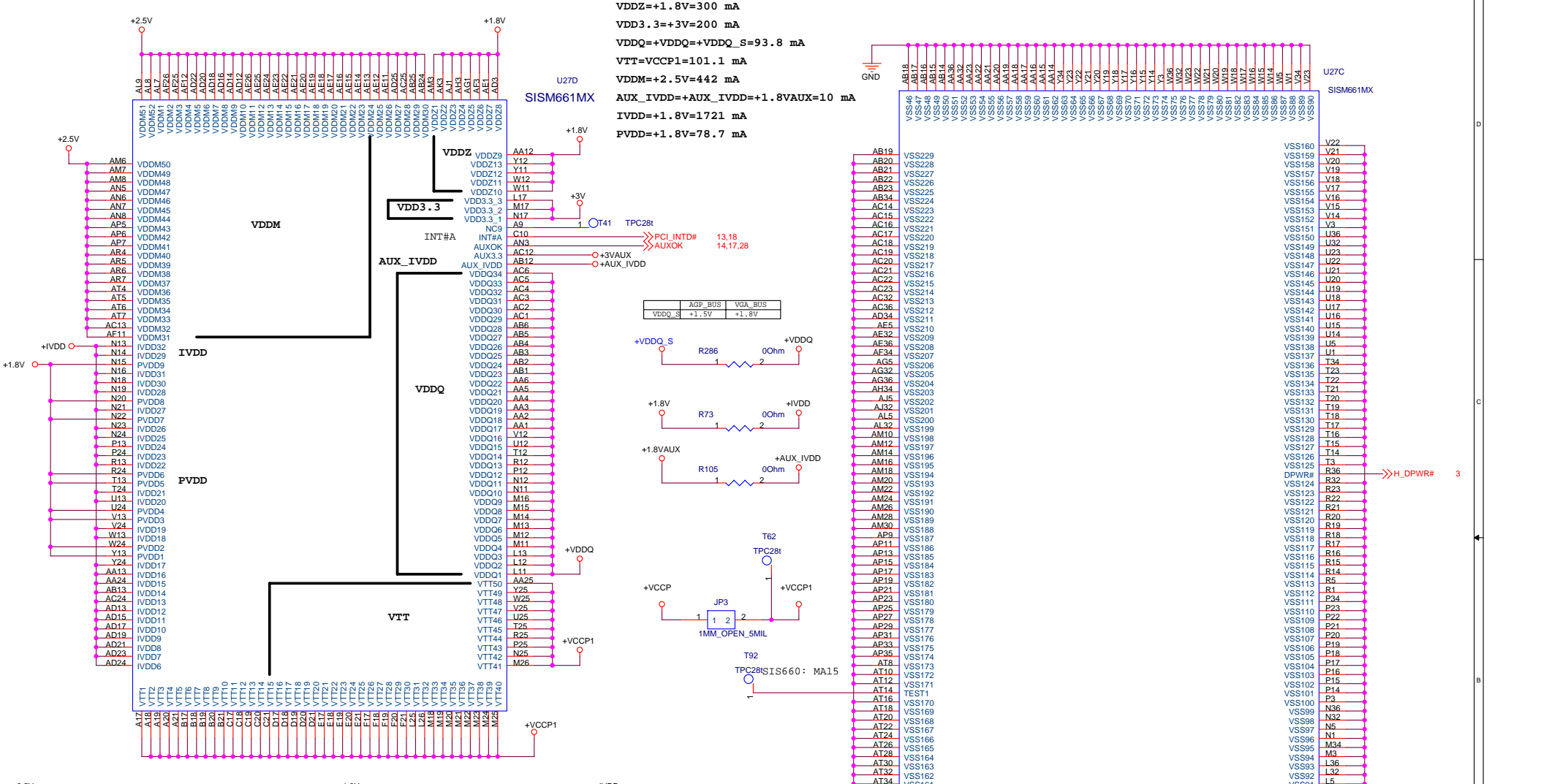

VDDZ=+1.8V=300 mA
VDD3.3=+3V=200 mA
VDDQ=+VDDQ+VDDQ_S=93.8 mA
VTT=VCCP1=101.1 mA
VDDM=+2.5V=442 mA
AUX_IVDD=+AUX_IVDD=+1.8VAUX=10 mA
IVDD=+1.8V=1721 mA
FVDD=+1.8V=78.7 mA

	AGP_BUS	VGA_BUS
VDDQ_S	+1.5V	+1.8V

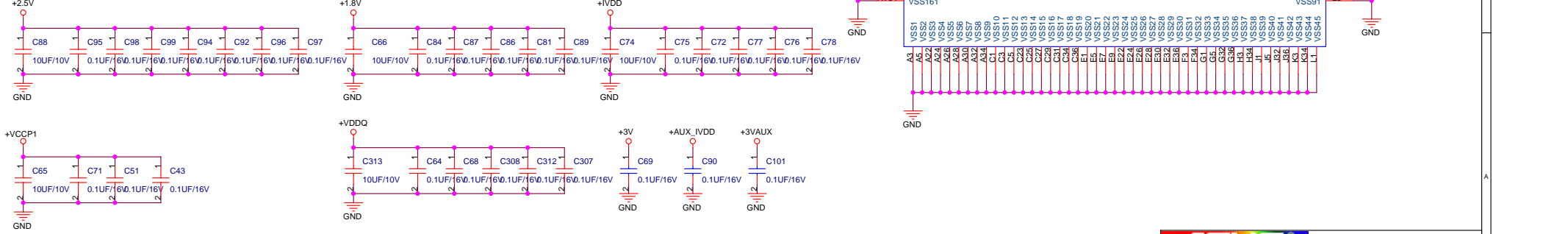
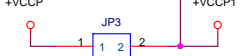
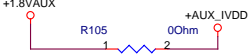
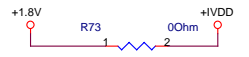
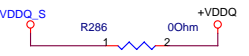

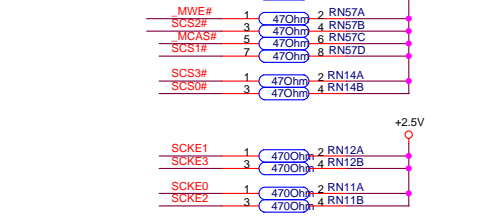
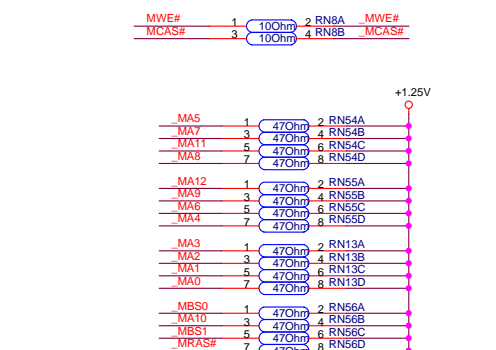
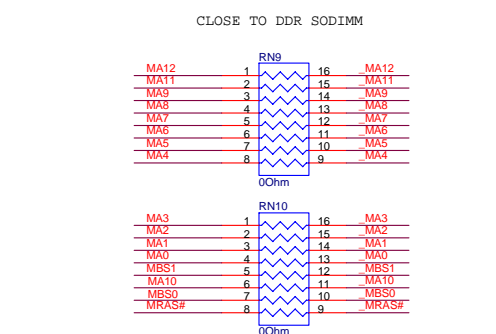
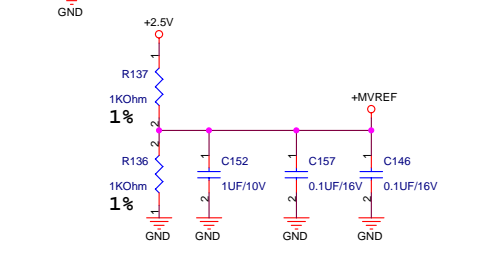
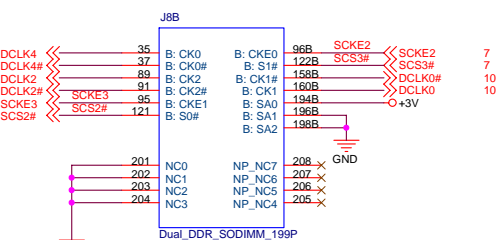
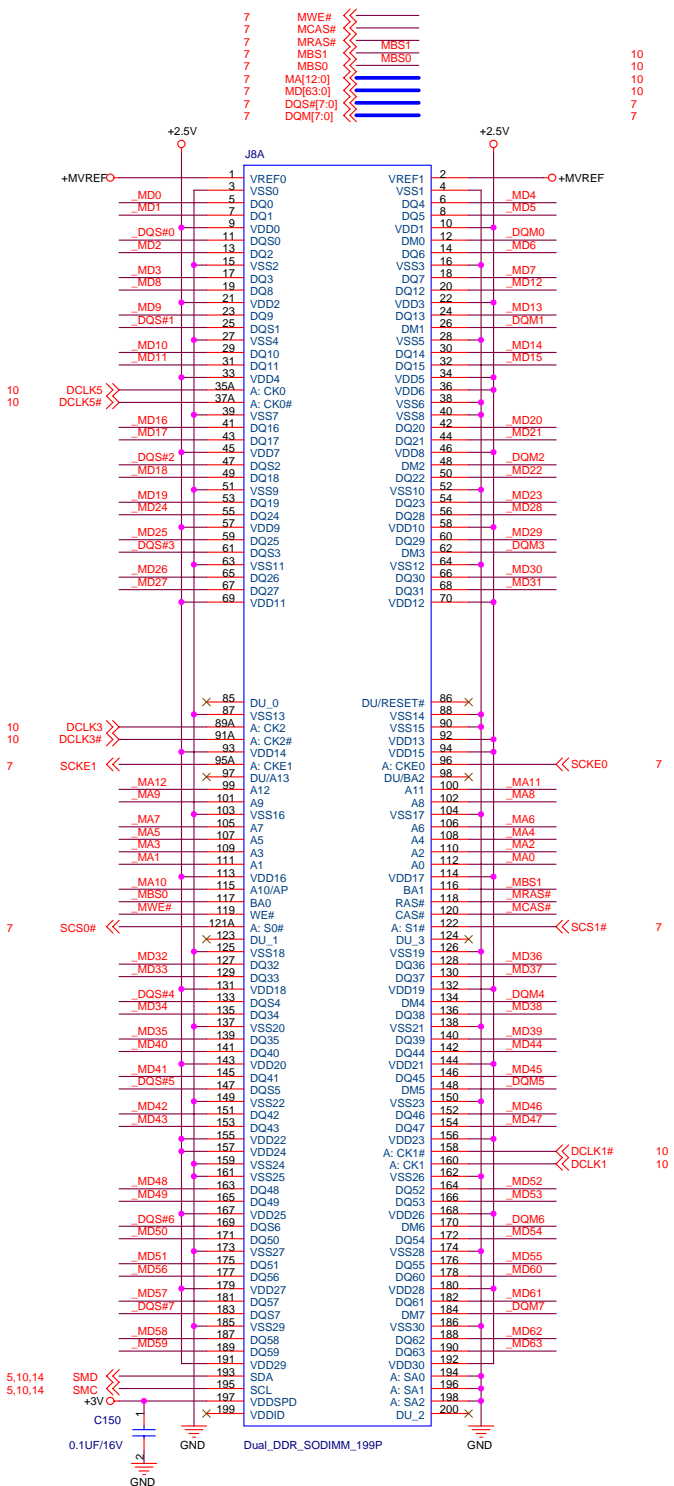

CLOSE TO DDR SODIMM

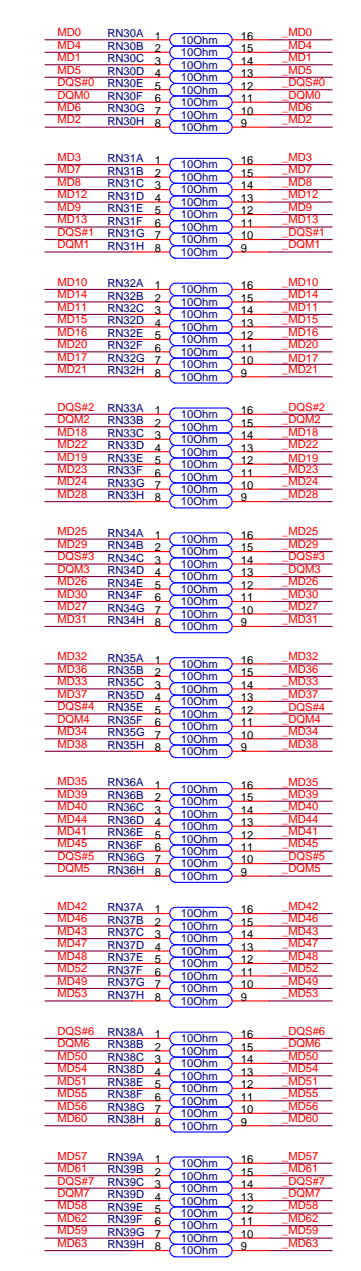

CHANGE TO 47 OHM

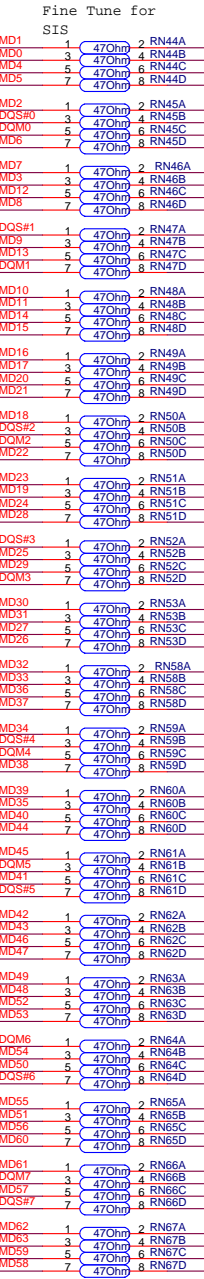

ASUS Title : **DDR MEMORY DIMM**

ASUSTek COMPUTER INC. Engineer: _____

Size: Custom Project Name: **Z94**

Date: Tuesday, May 31, 2005 Sheet 9 of 38

Close to DDR socket

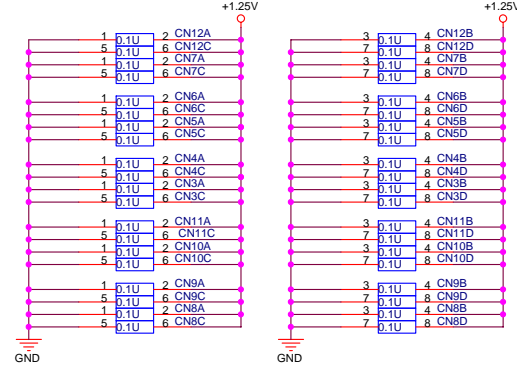
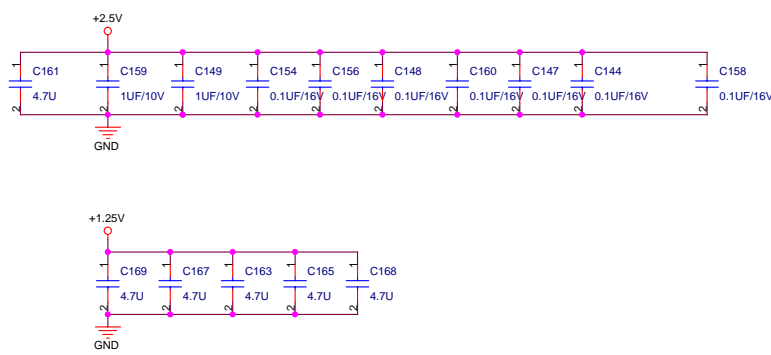

0.1U OP X 4

DDR BUFFER

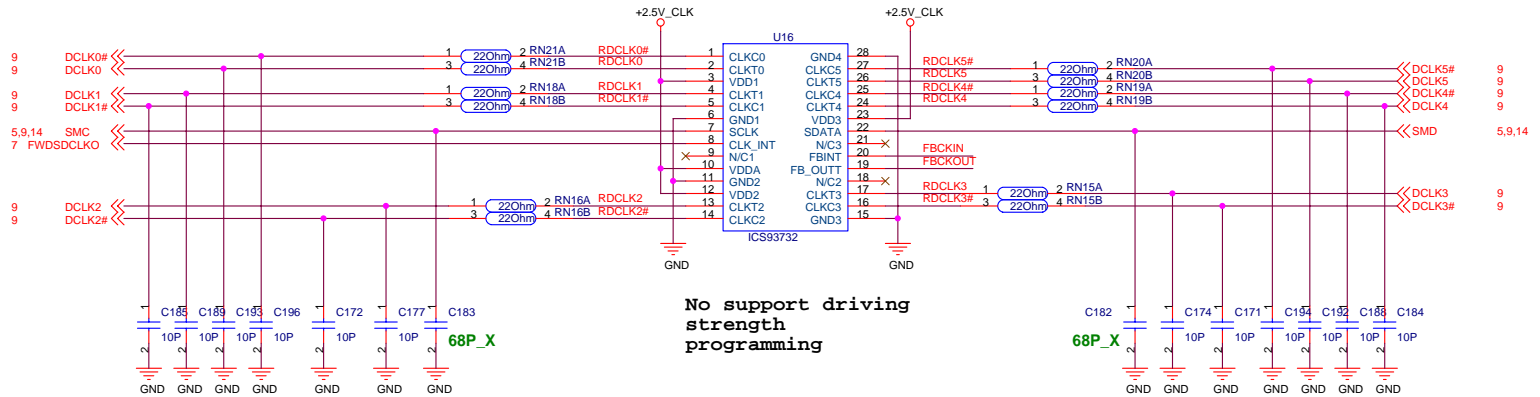
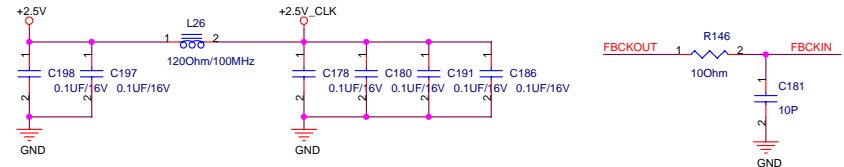

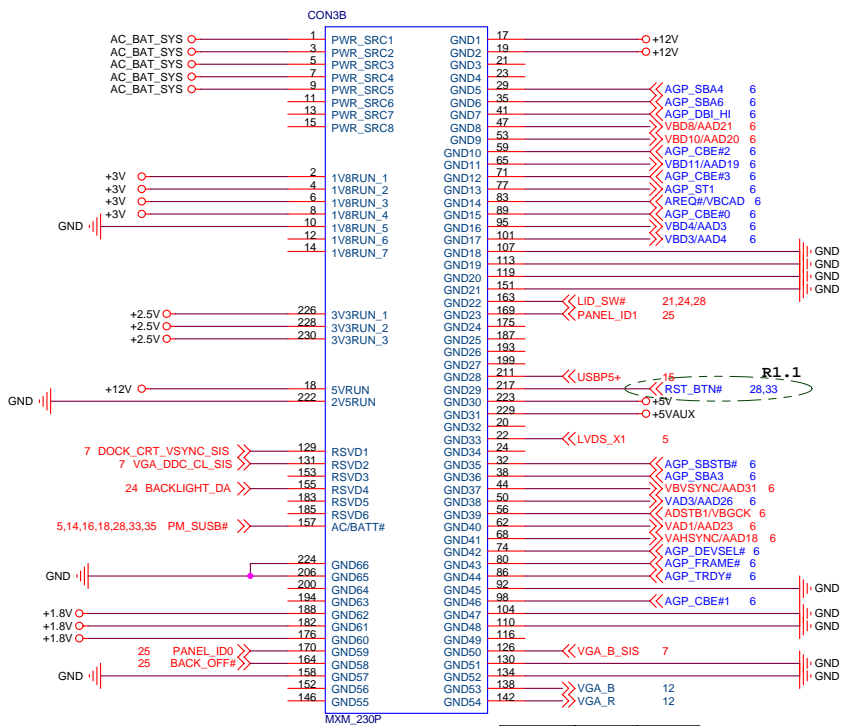

1. AC_BAT_SYS ----> 2 A
2. +12V = 0.5A
3. +5V = 1.5A
4. +3V = 1.5A
5. +2.5V = 2.0A
6. +1.8V = 2.0A
7. +5VAUX = 1.0A
7. +1.5V----> 0.5A

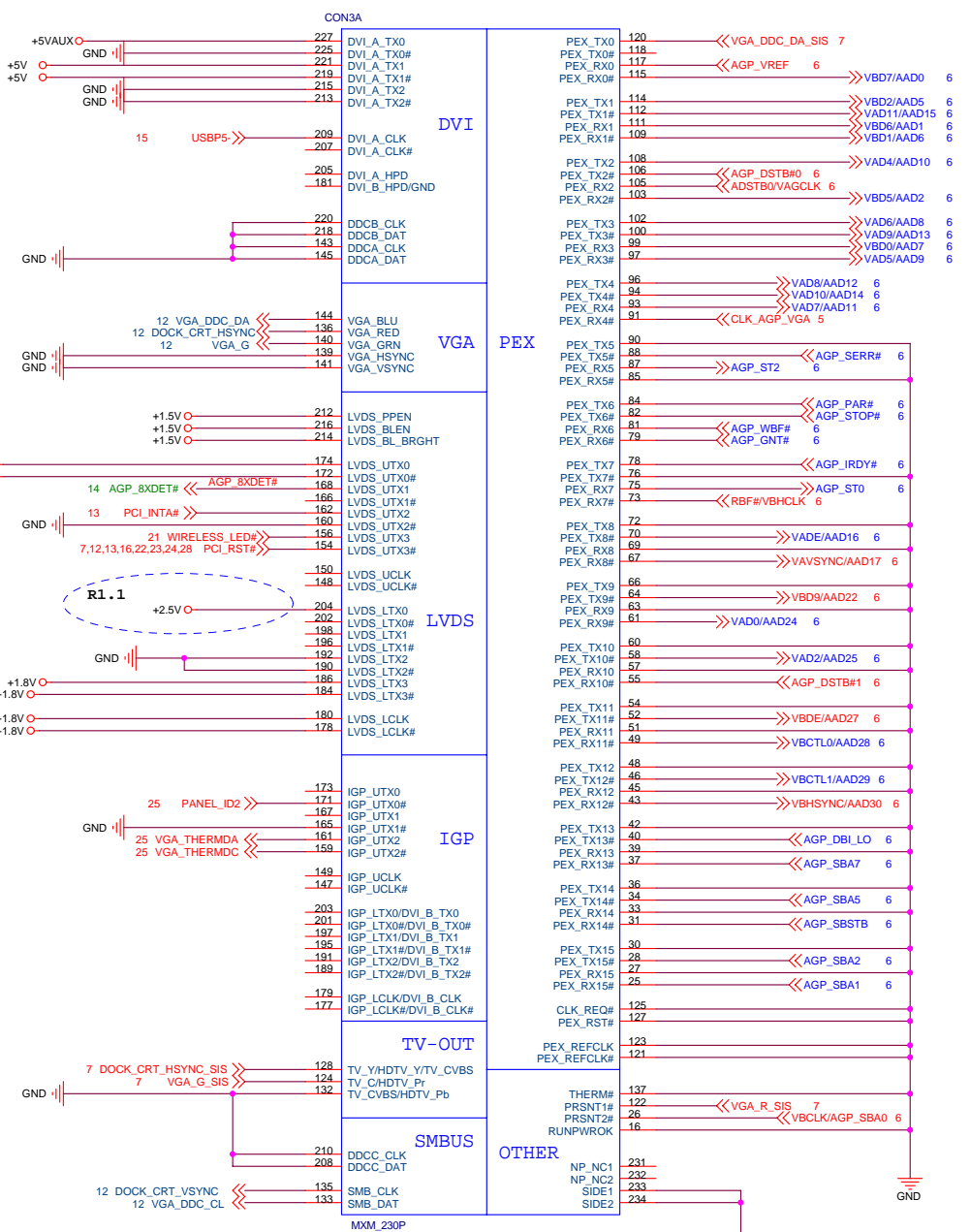
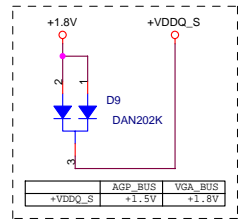
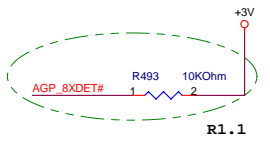

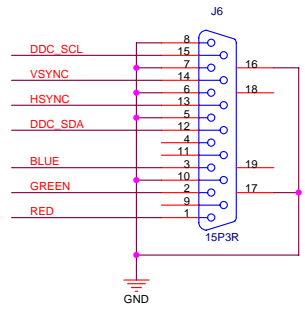
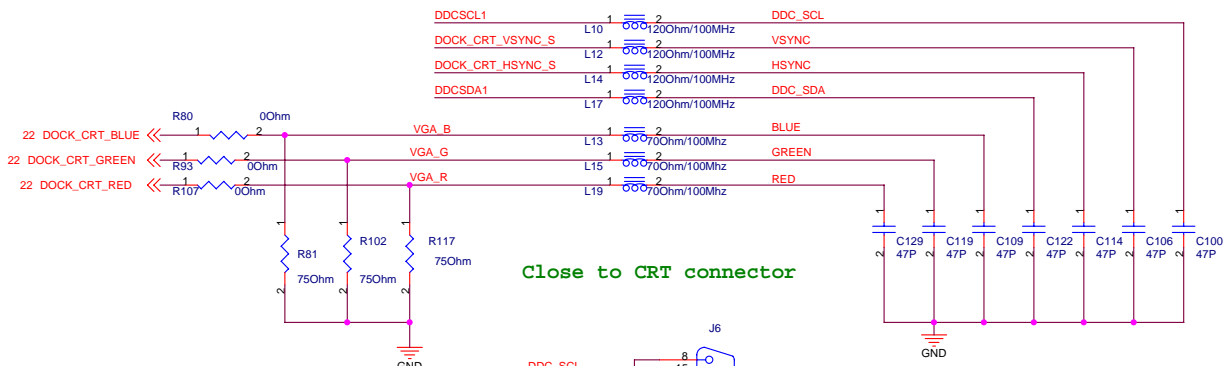

CRT connector

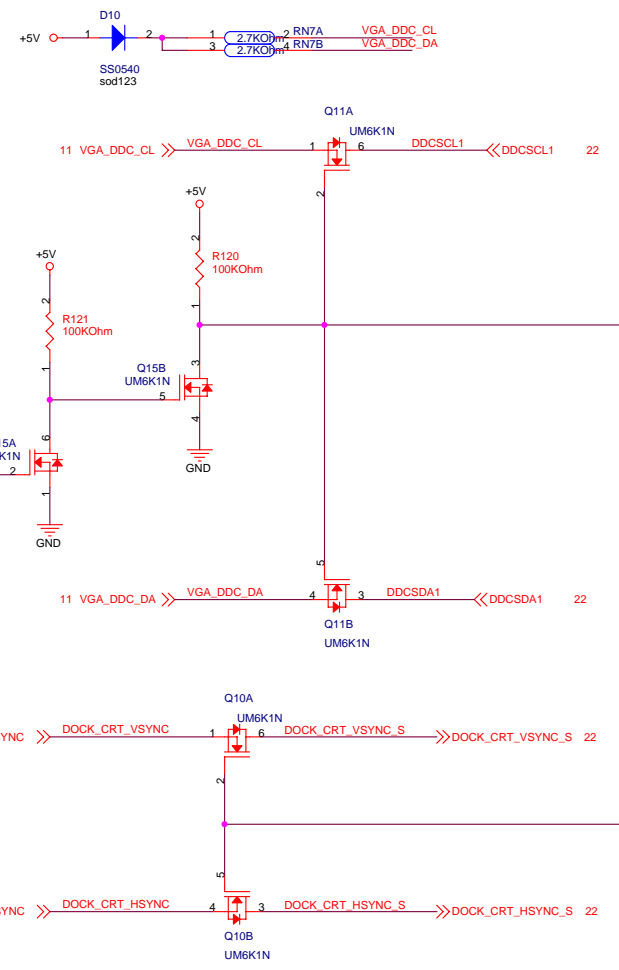
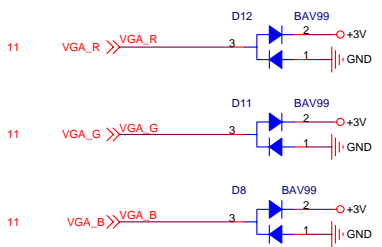

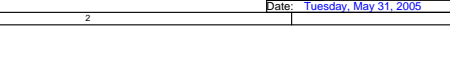
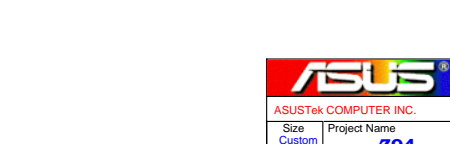
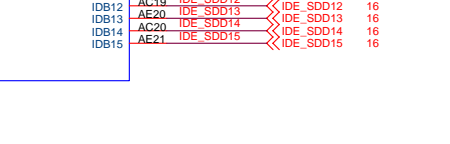
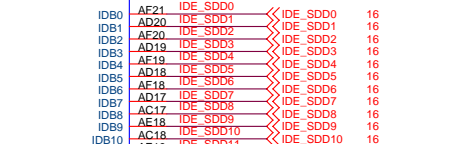
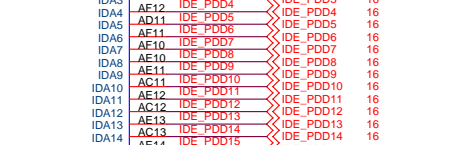
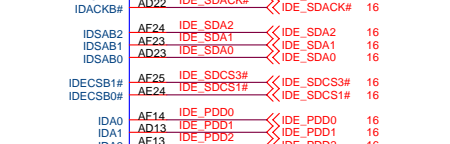
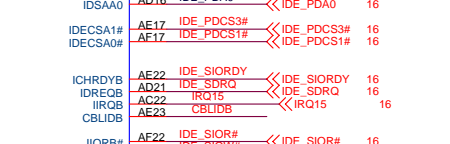
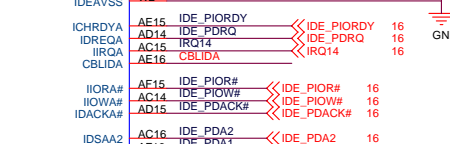
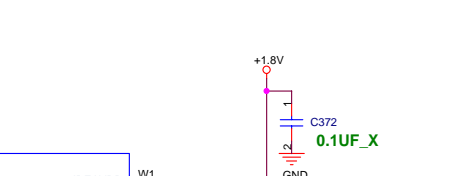
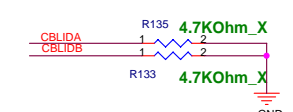
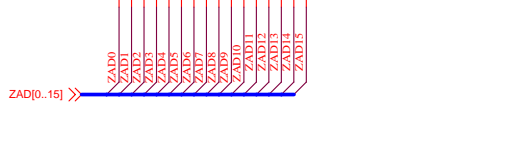
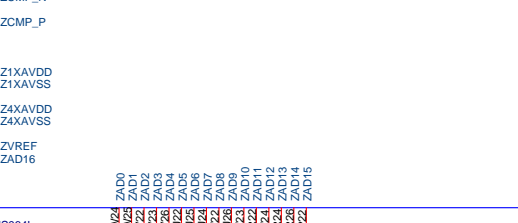
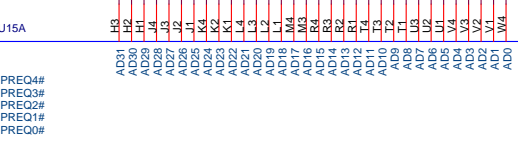
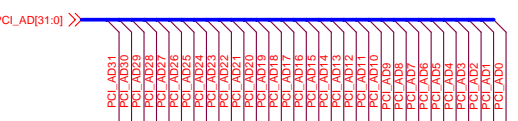
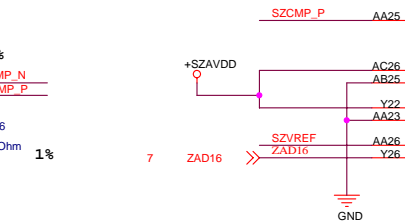
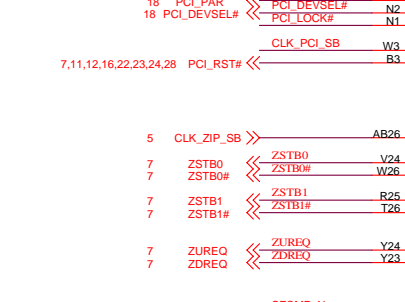
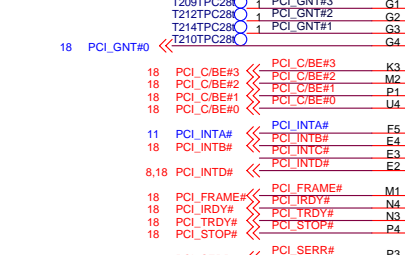
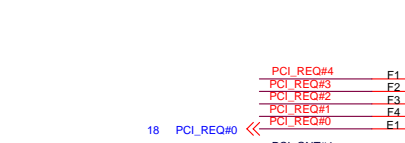
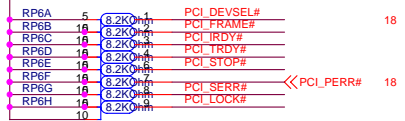
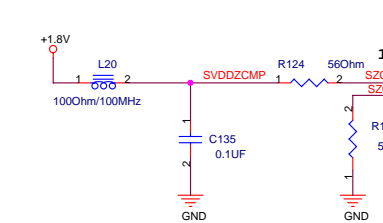
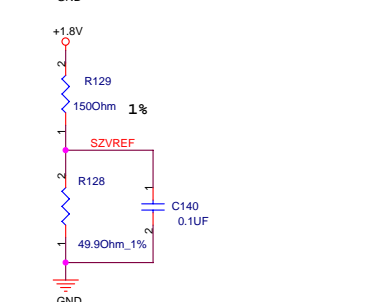
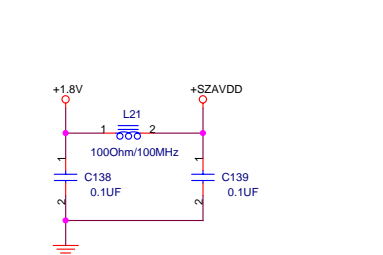
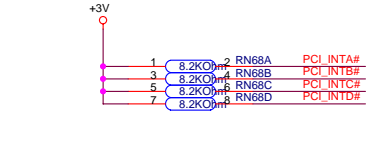
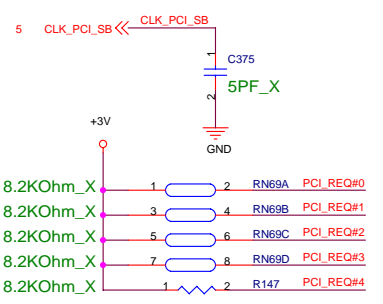

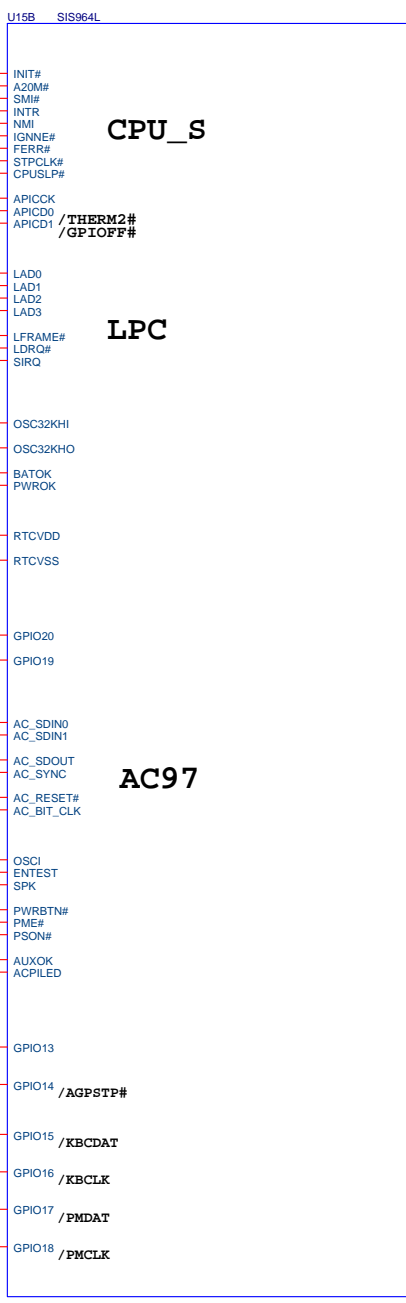
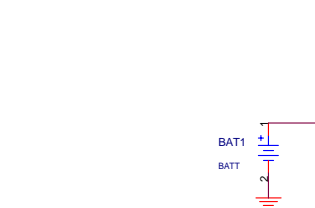
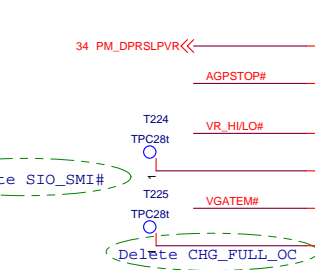
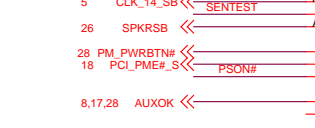
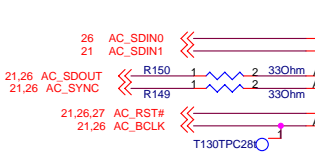
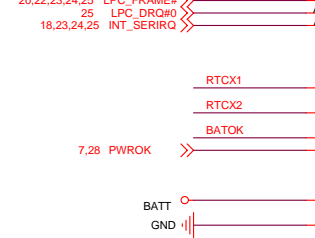
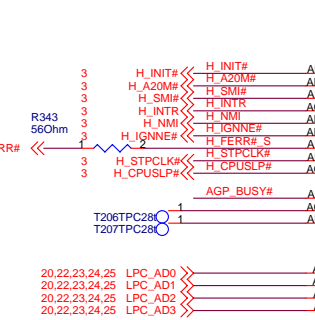
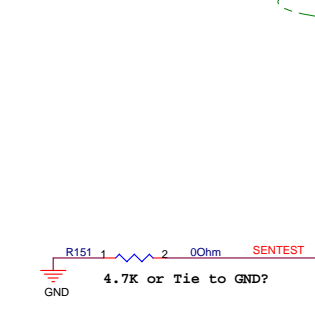
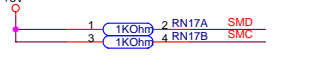
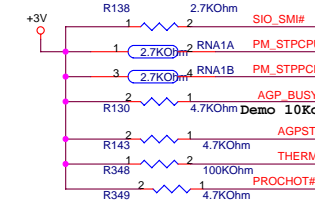
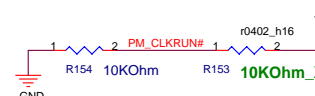
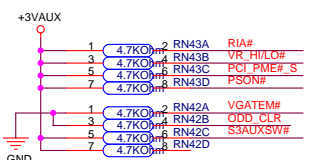
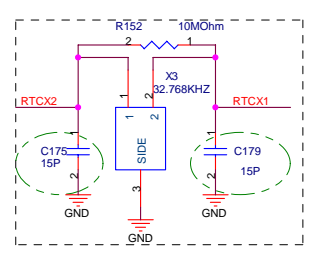
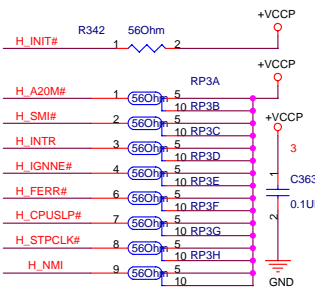

CPU_S

LPC

AC97

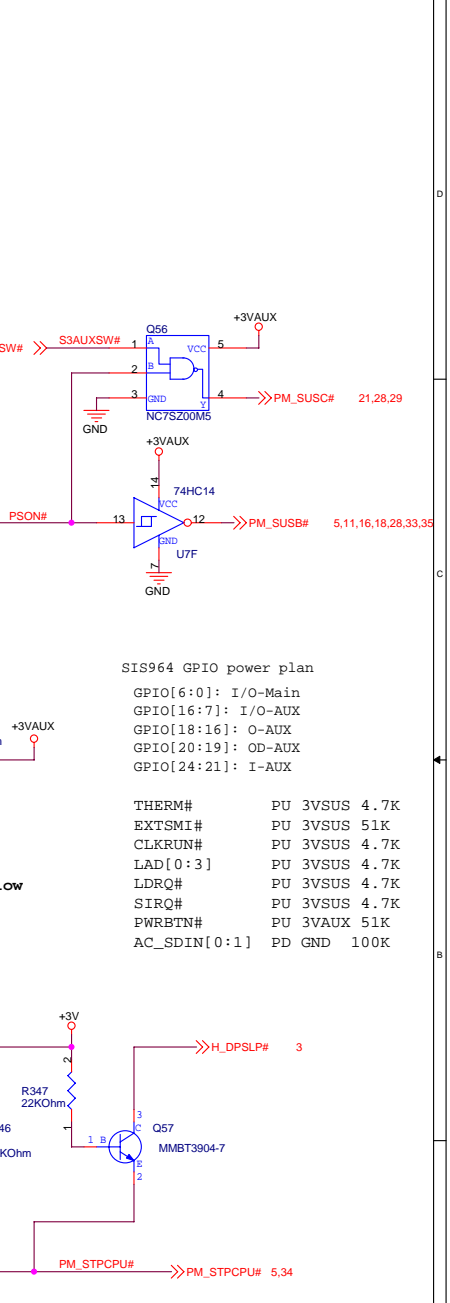
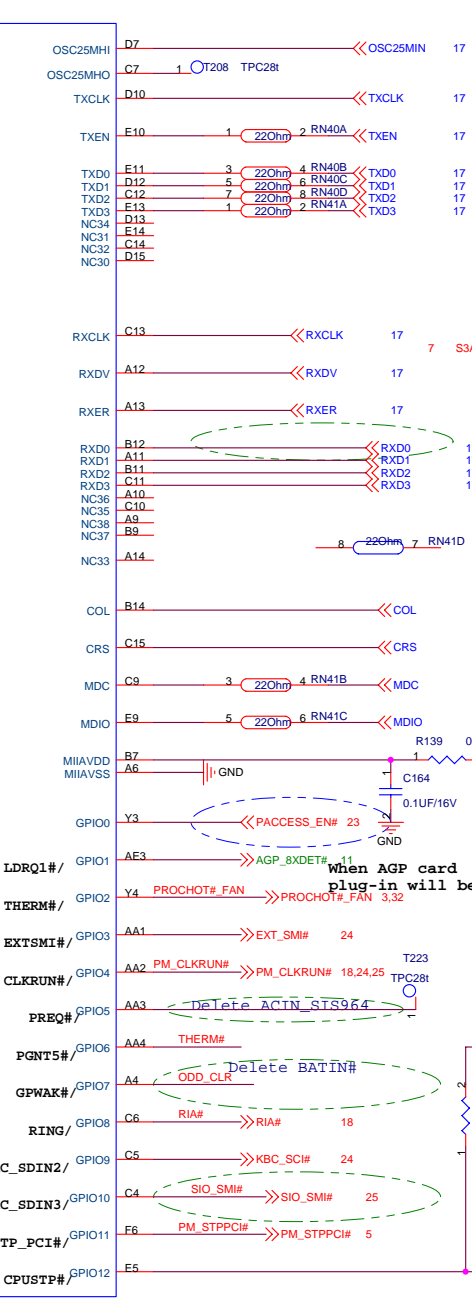

SIS964 GPIO power plan
 GPIO[6:0]: I/O-Main
 GPIO[16:7]: I/O-AUX
 GPIO[18:16]: O-AUX
 GPIO[20:19]: OD-AUX
 GPIO[24:21]: I-AUX

THERM# PU 3VSUS 4.7K
 EXTSMI# PU 3VSUS 51K
 CLKRUN# PU 3VSUS 4.7K
 LAD[0:3] PU 3VSUS 4.7K
 LDRQ# PU 3VSUS 4.7K
 SIRQ# PU 3VSUS 4.7K
 PWRBTN# PU 3VAUX 51K
 AC_SDIN[0:1] PD GND 100K

when AGP card plug-in will be low

Delete ACTN_SIS964
 Delete BATIN#
 Delete SIO_SMI#

RTC Battery

ASUS Title : SIS964L_LPC/AC97/GPIO
 ASUSTek COMPUTER INC. Engineer: -
 Size Project Name
 Custom T19
 Date: Tuesday, May 31, 2005 Sheet 14 of 38

USB frequency

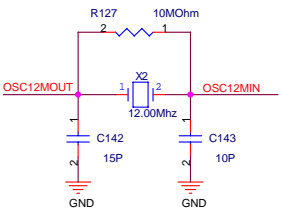

UVDD33=+3VAUX=1mA
 UVDD18=UVDD18=+1.8VAUX=274.1mA
 USBPVD18=USBPVDD18=+1.8VAUX=7.9 mA
 USBCMPVDD=+USBCMPVDD=+3VAUX=8.5 mA
 IVDD_AUX=+1.8VAUX=31.1mA

VDDZ=+1.8V=20 mA
 IVDD=+1.8V=517.4 mA
 PVDD=+3V=55 mA
 OVDD=+3V=55 mA
 VTT=+VCCP=28.7 mA
 IVDD_AUX=+1.8VAUX=31.1 mA
 OVDD_AUX=+3VAUX=52 mA

SIS964L

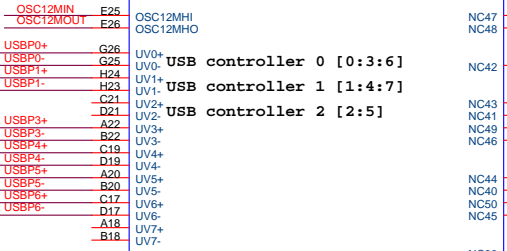

USB overcurrent detect

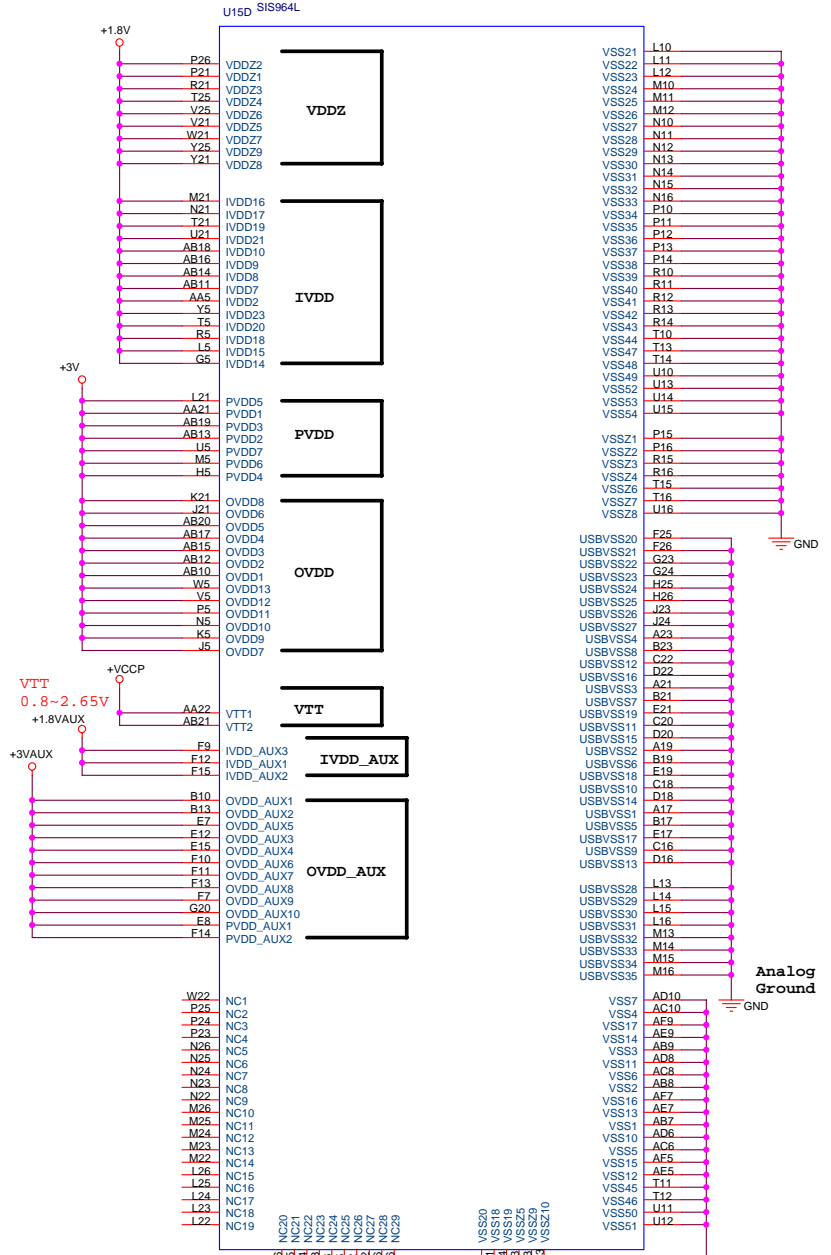
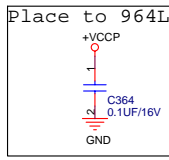
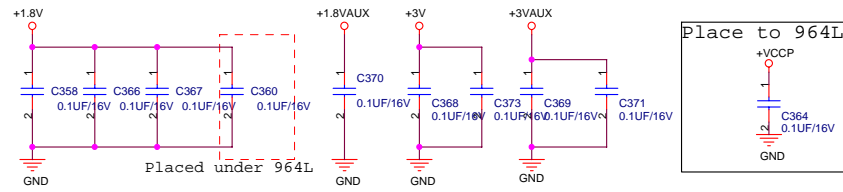
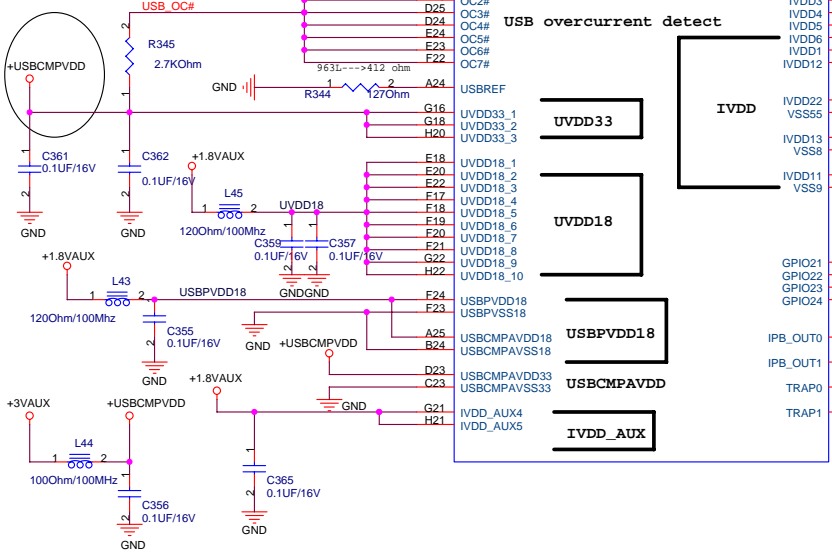

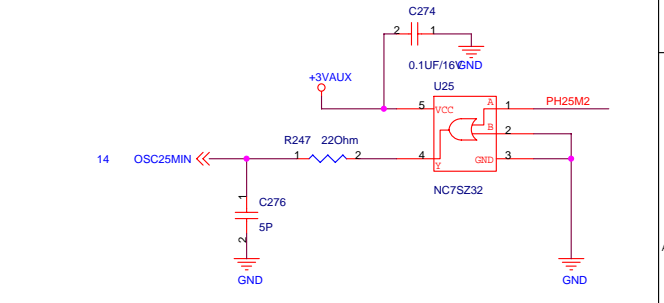
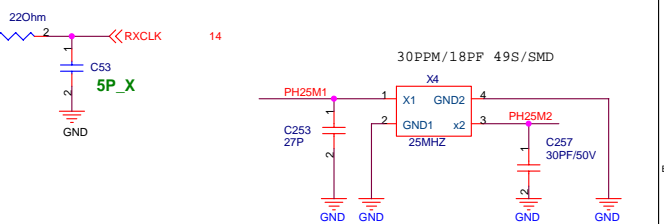
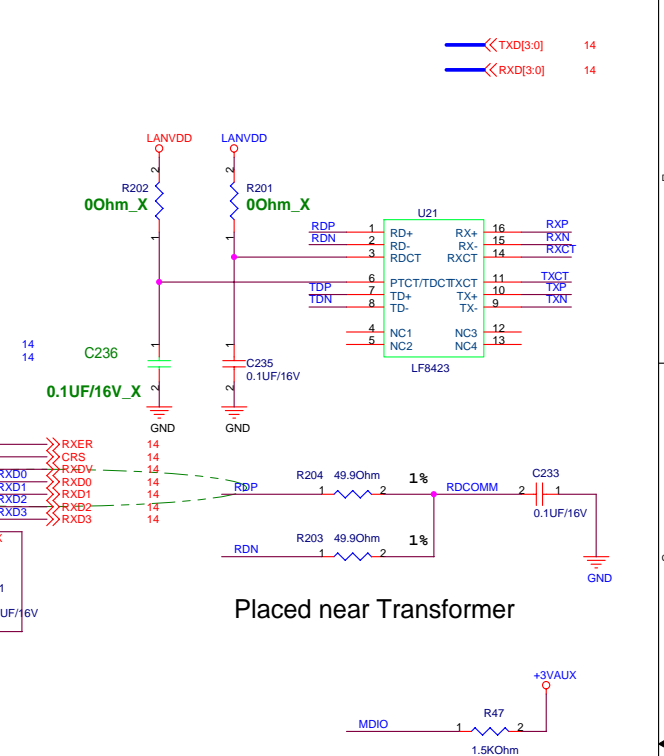
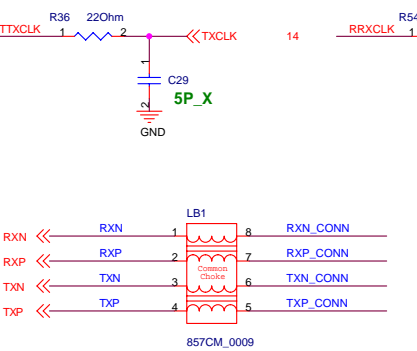
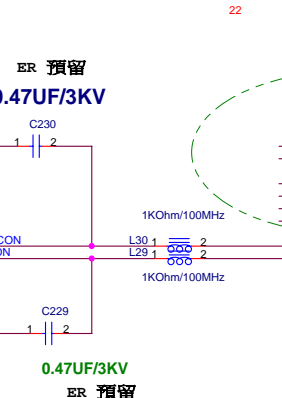
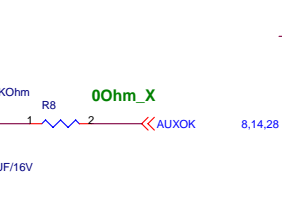
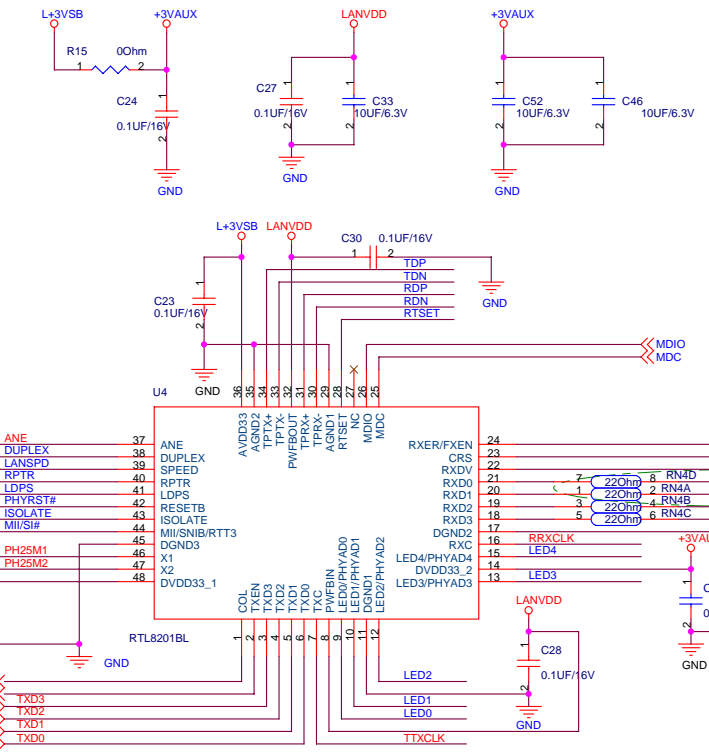
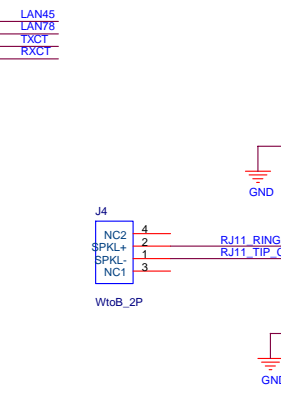
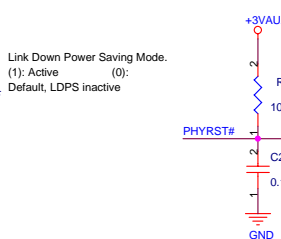
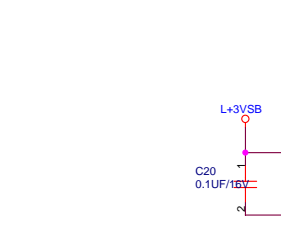
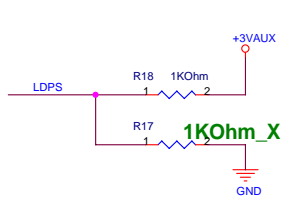
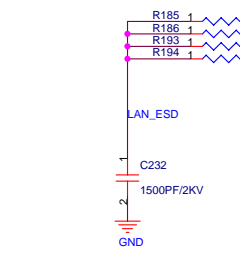
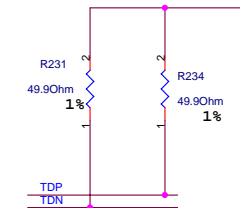
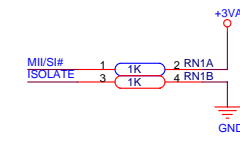
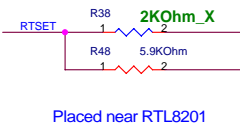
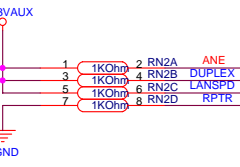
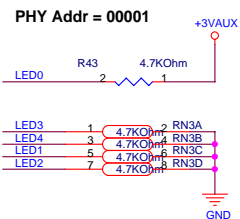

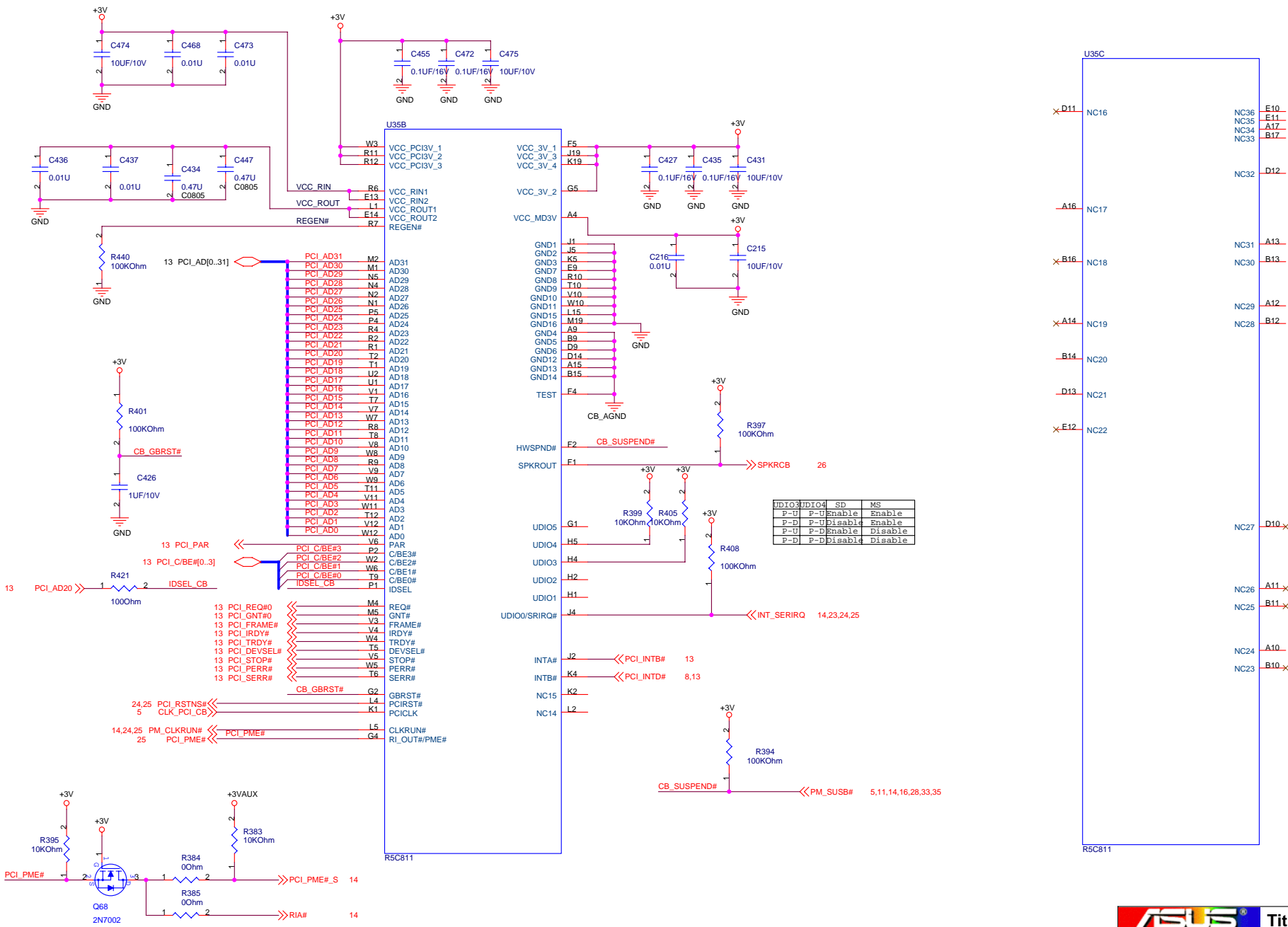

PCMCIA DEBUG

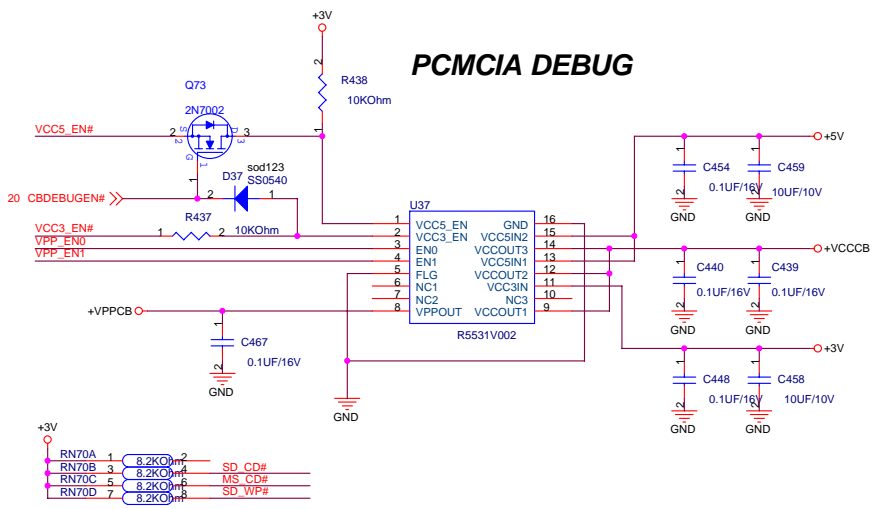

- MDIO01--> MS Card Detect
- MDIO03--> SD Write Protect
- MDIO04--> SD Card Power0 Control/ MS Power Control
- MDIO07--> SD External Clock/ MS External Clock
- MDIO08--> SD Command/MS Bus State
- MDIO09--> SD Clock/MS Clock
- MDIO10--> SD Data 0/MS Data 0
- MDIO11--> SD Data 1/MS Data 1
- MDIO12--> SD Data 2/MS Data 2
- MDIO13--> SD Data 3/MS Data 3

- MDIO02--> xDCE#
- MDIO05--> SD Power Control 1 / xDWP
- MDIO06--> xD/MS/SD LED Control
- MDIO14--> xD Data
- MDIO15--> xD Data
- MDIO16--> xD Data
- MDIO17--> xD Data
- MDIO18--> xD CLE
- MDIO19--> xD ALE

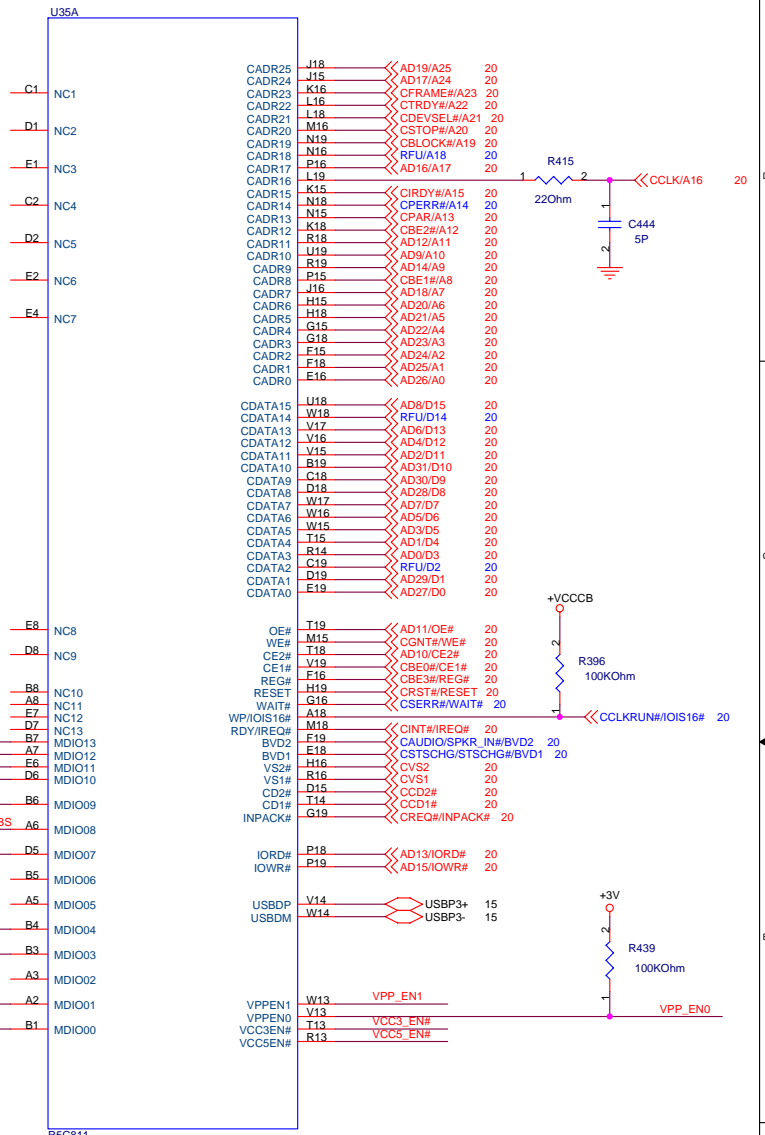

Memory Card Detect

MS_CD#	SD_CD#	Not Support
0	0	Not Support
1	0	Small Card
1	1	Memory Stick

MC_CD# : Memory Card Detect

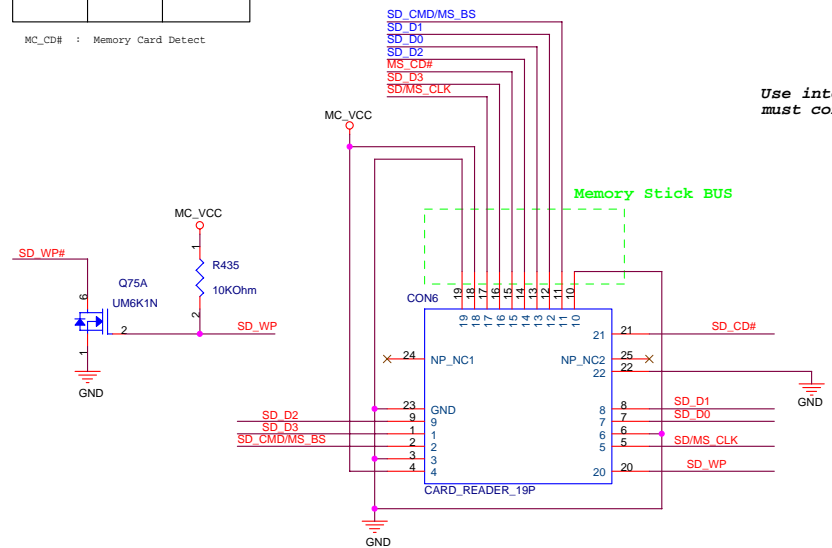

Use internal PCI clock MDIO07 must connect to GND

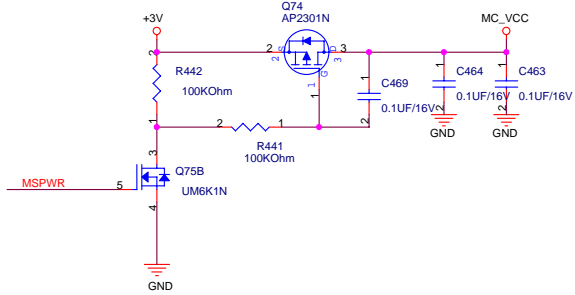

PCMCIA SOCKET

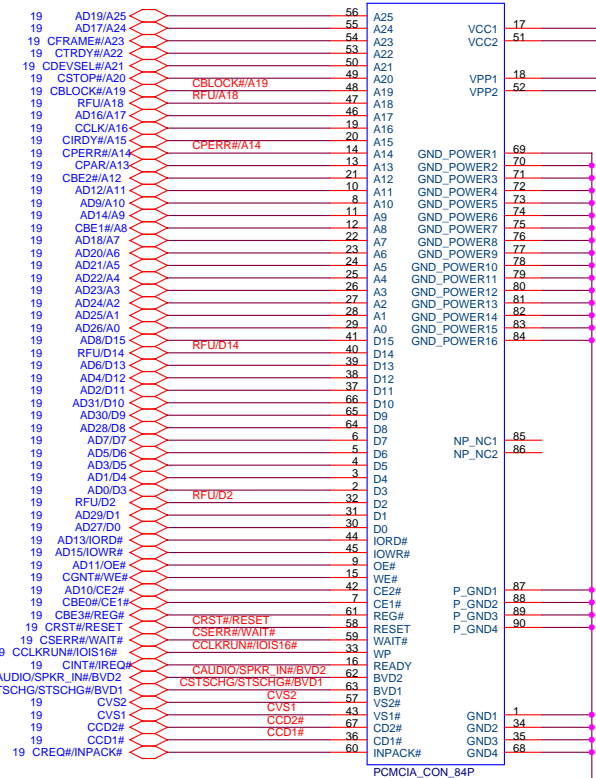

14,22,23,24,25 CLK_PCL_DB
 14,22,23,24,25 LPC_FRAME#
 14,22,23,24,25 LPC_AD0
 14,22,23,24,25 LPC_AD2
 14,22,23,24,25 LPC_AD3
 22 DEBUG_EN

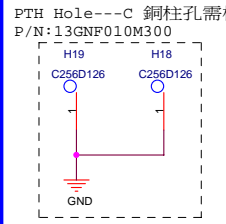
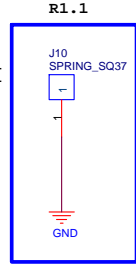
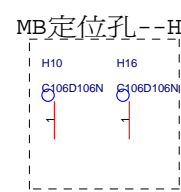
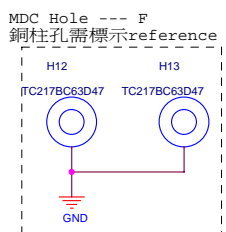
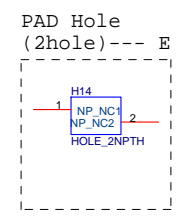
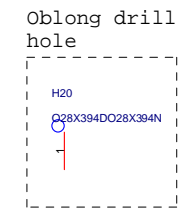
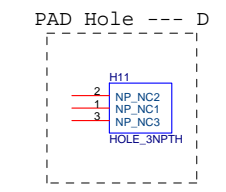
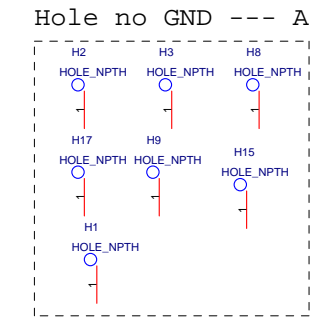
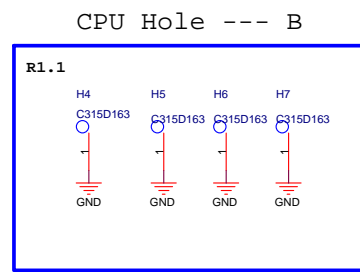
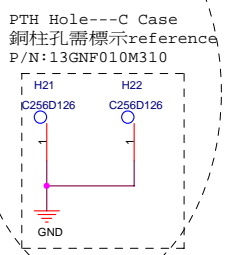
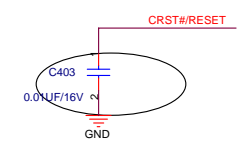
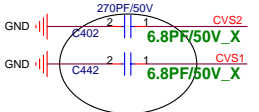
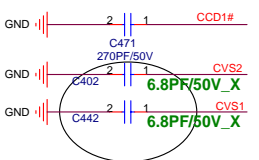
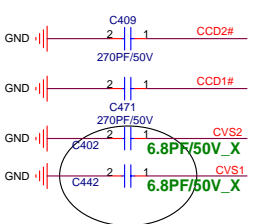
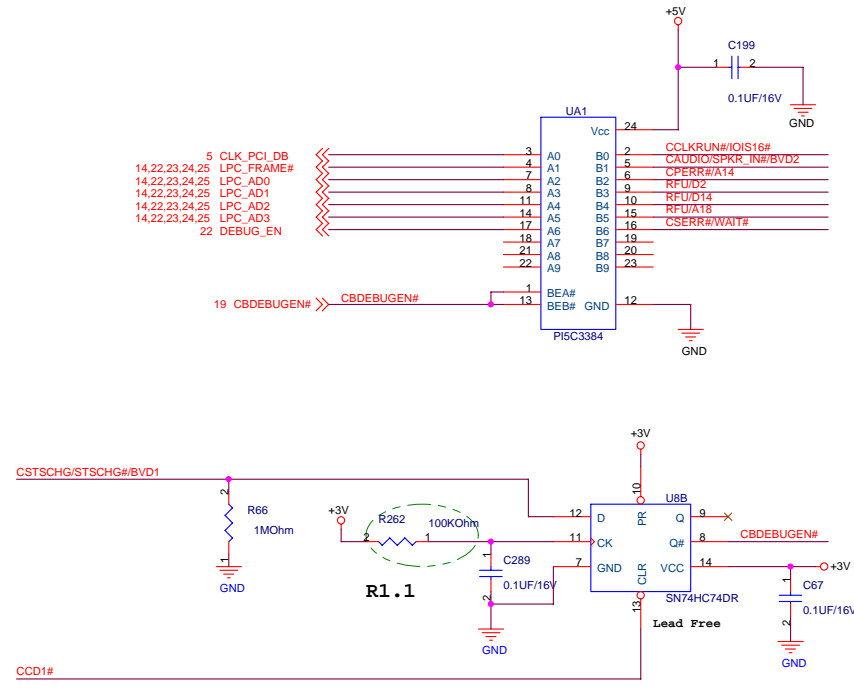

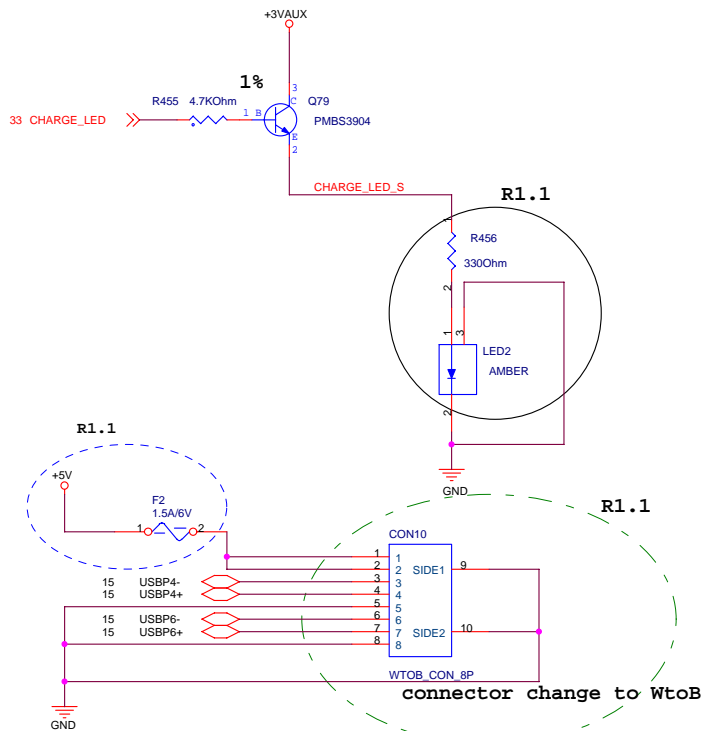
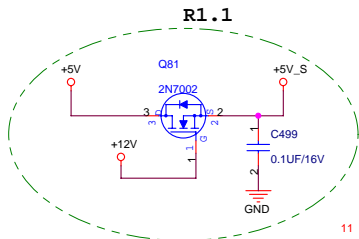
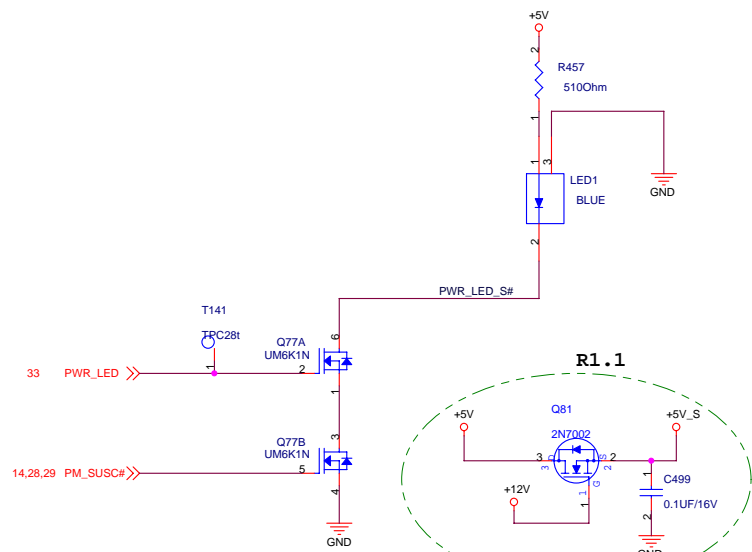

SPKL+,SPKL-,SPKR+,SPKR- trace 15mil width

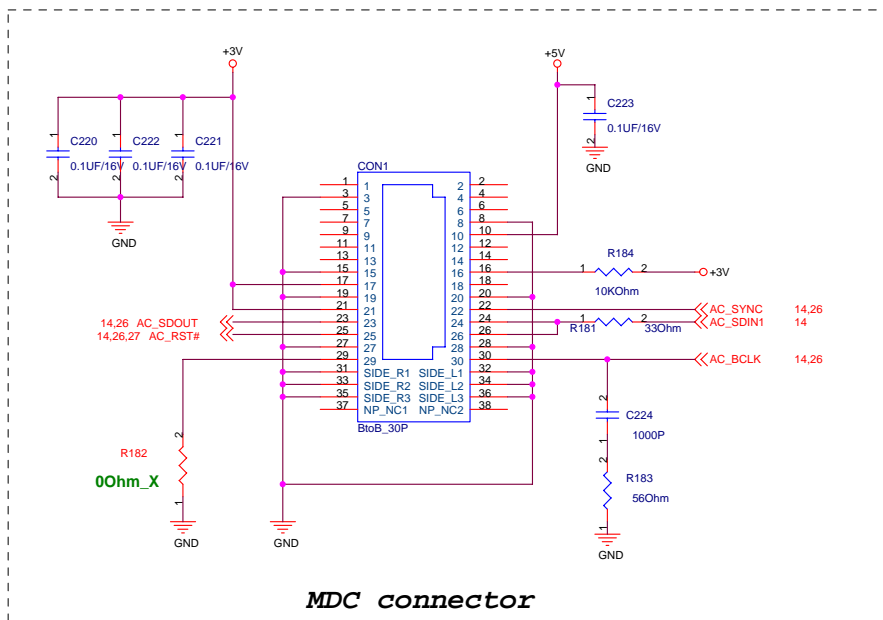
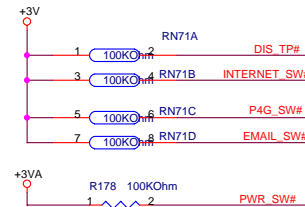
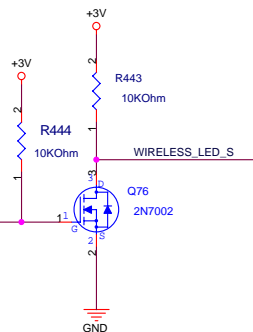
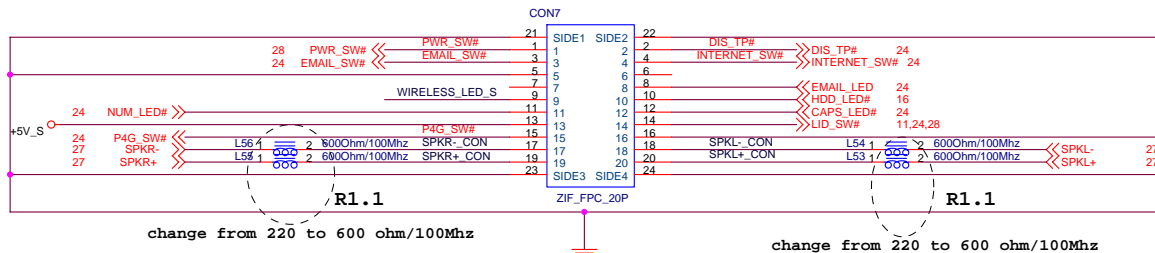

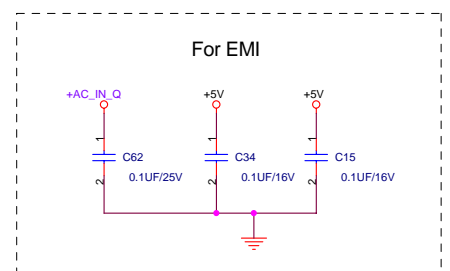
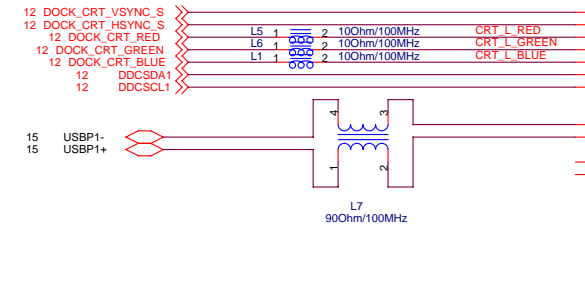
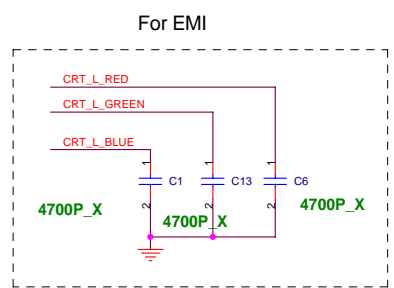
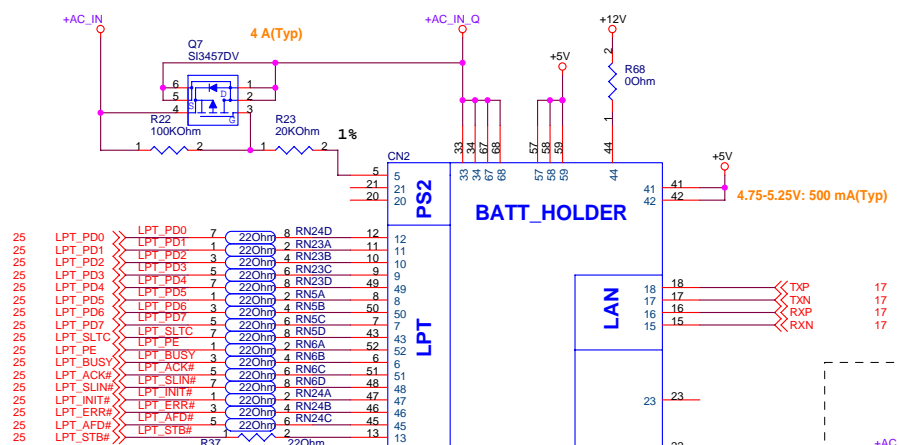
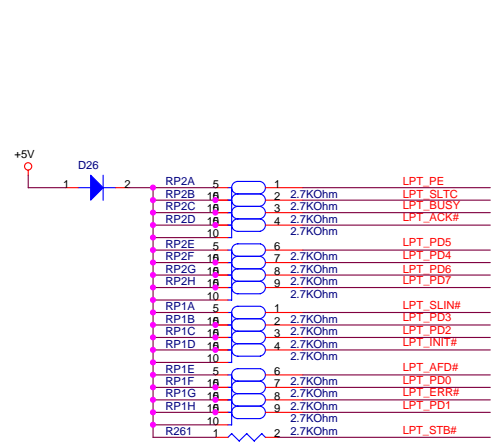
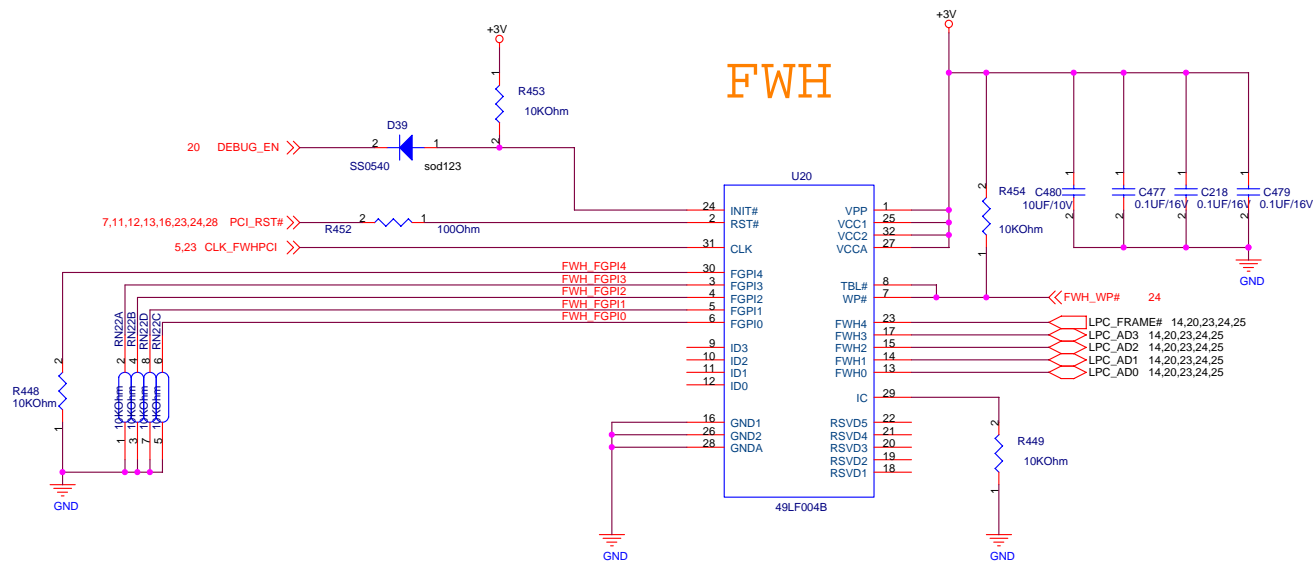

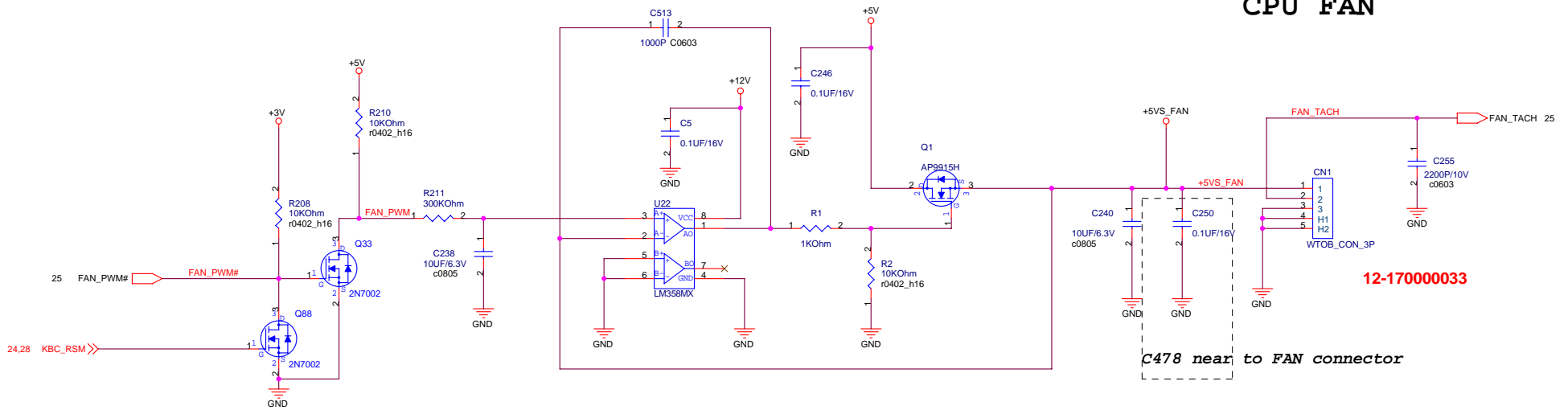

CPU FAN

12-17000033

C478 near to FAN connector

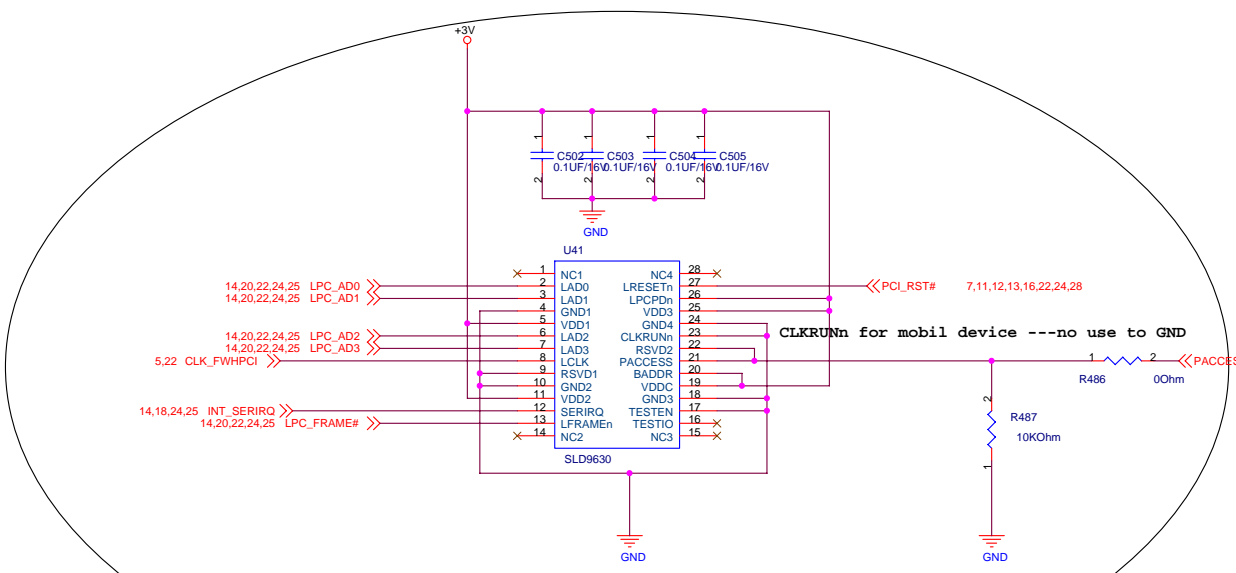

	2Eh/2Fh	4Eh/4Fh
BADDR	GND	VDD

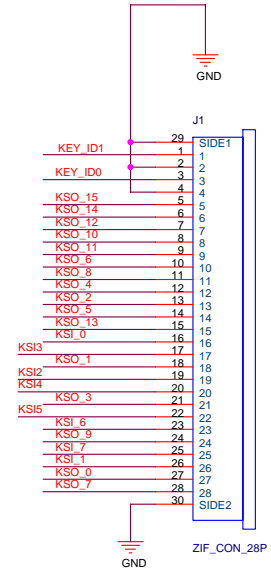
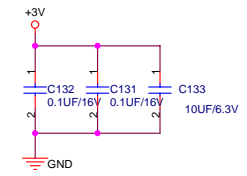
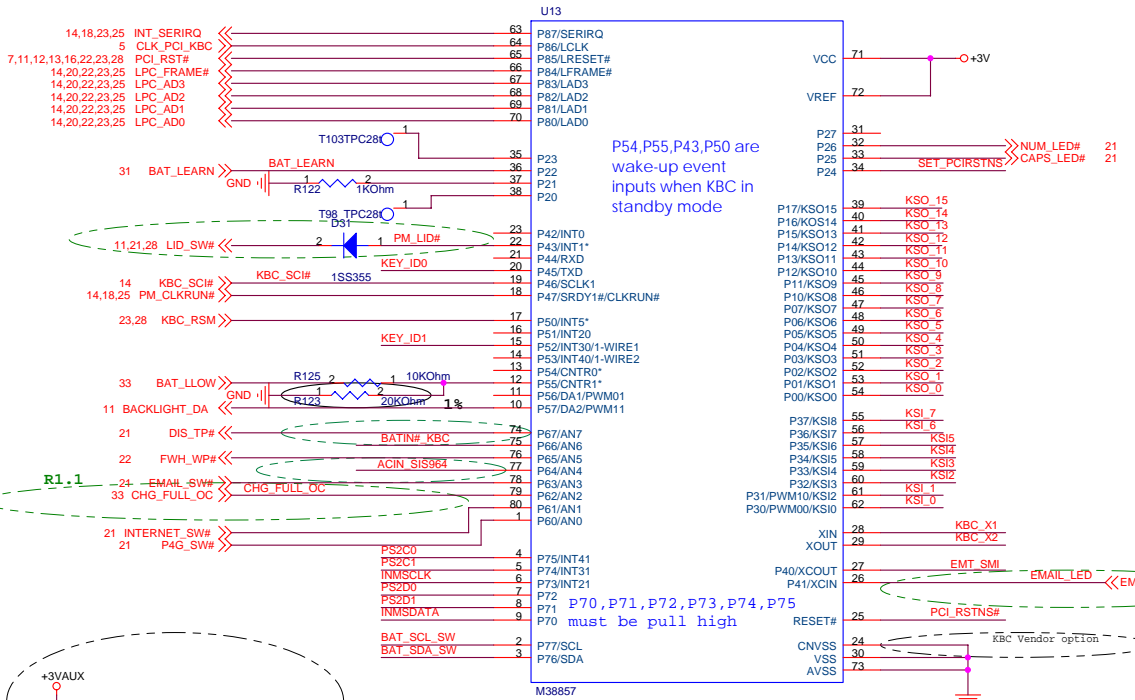

KEYBOARD CONNECTOR

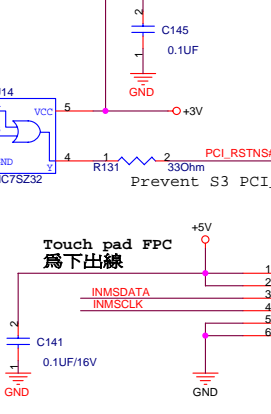
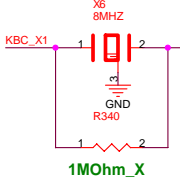
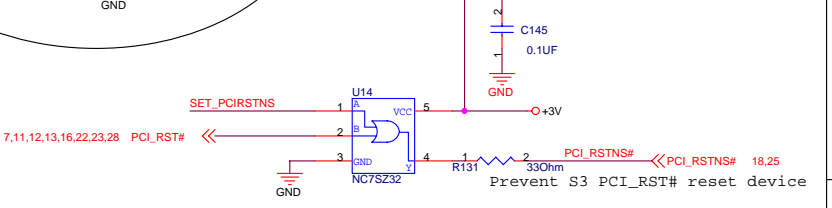
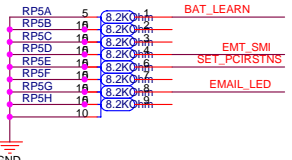
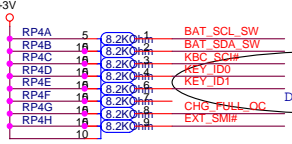
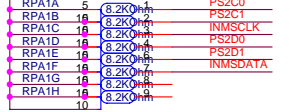
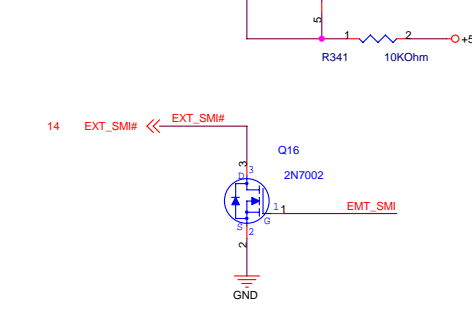
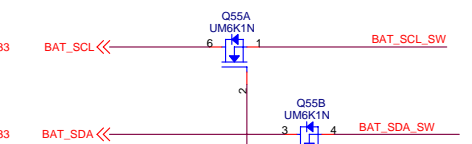
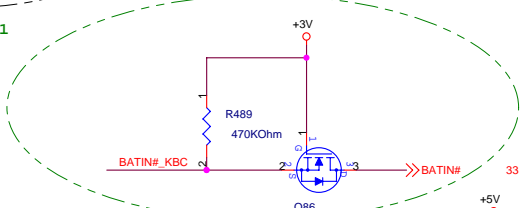
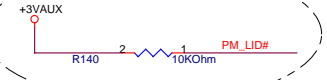
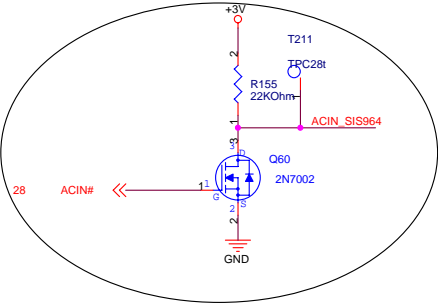

Touch pad connector

ASUS Title : KBC_M38857

ASUSTek COMPUTER INC. Engineer: -

Size	Project Name	Rev
Custom	T19	1.0

Date: Tuesday, May 31, 2005 Sheet 24 of 38

Super I/O

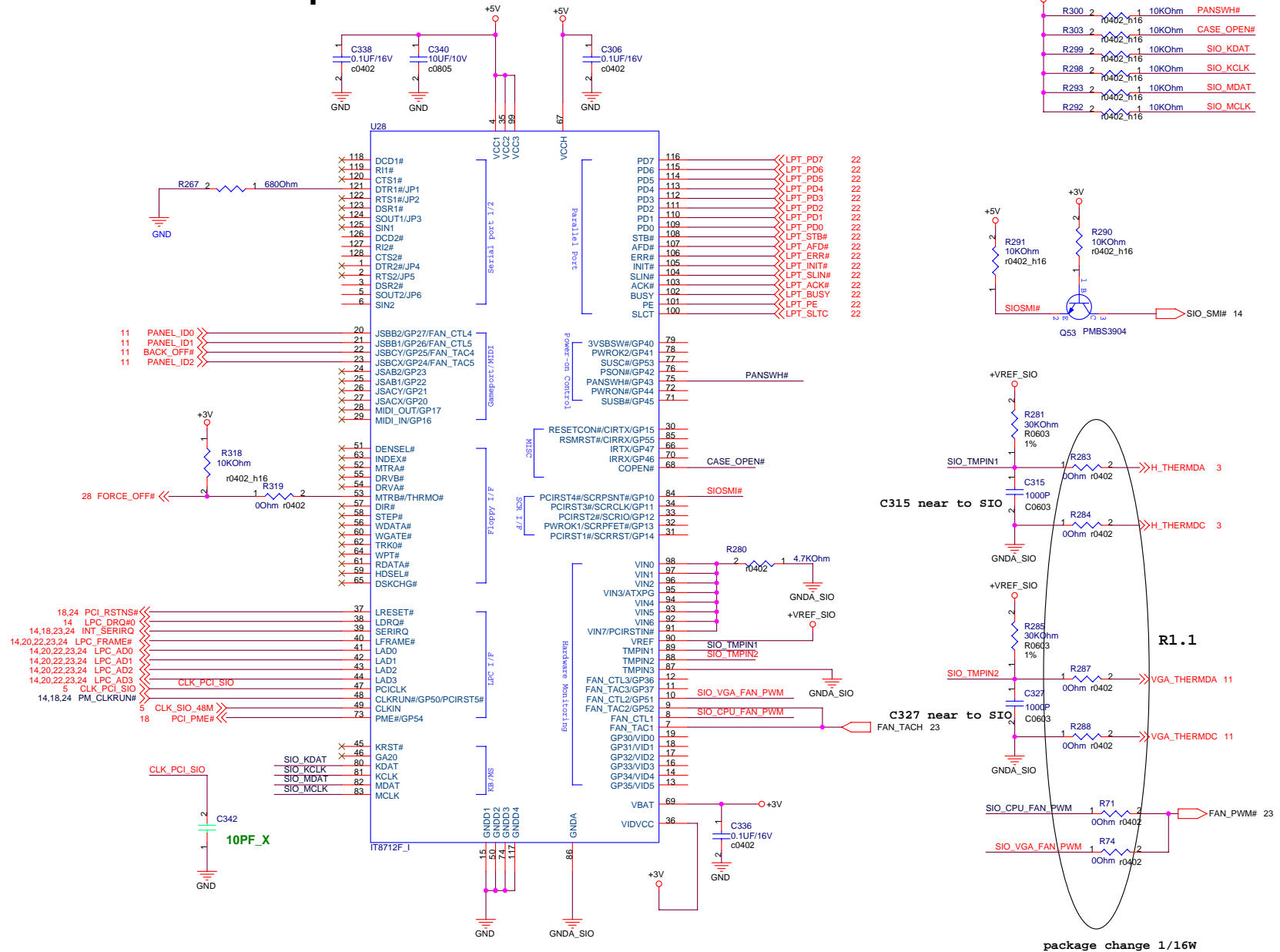

package change 1/16W

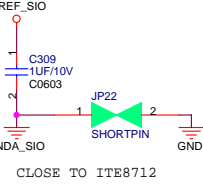

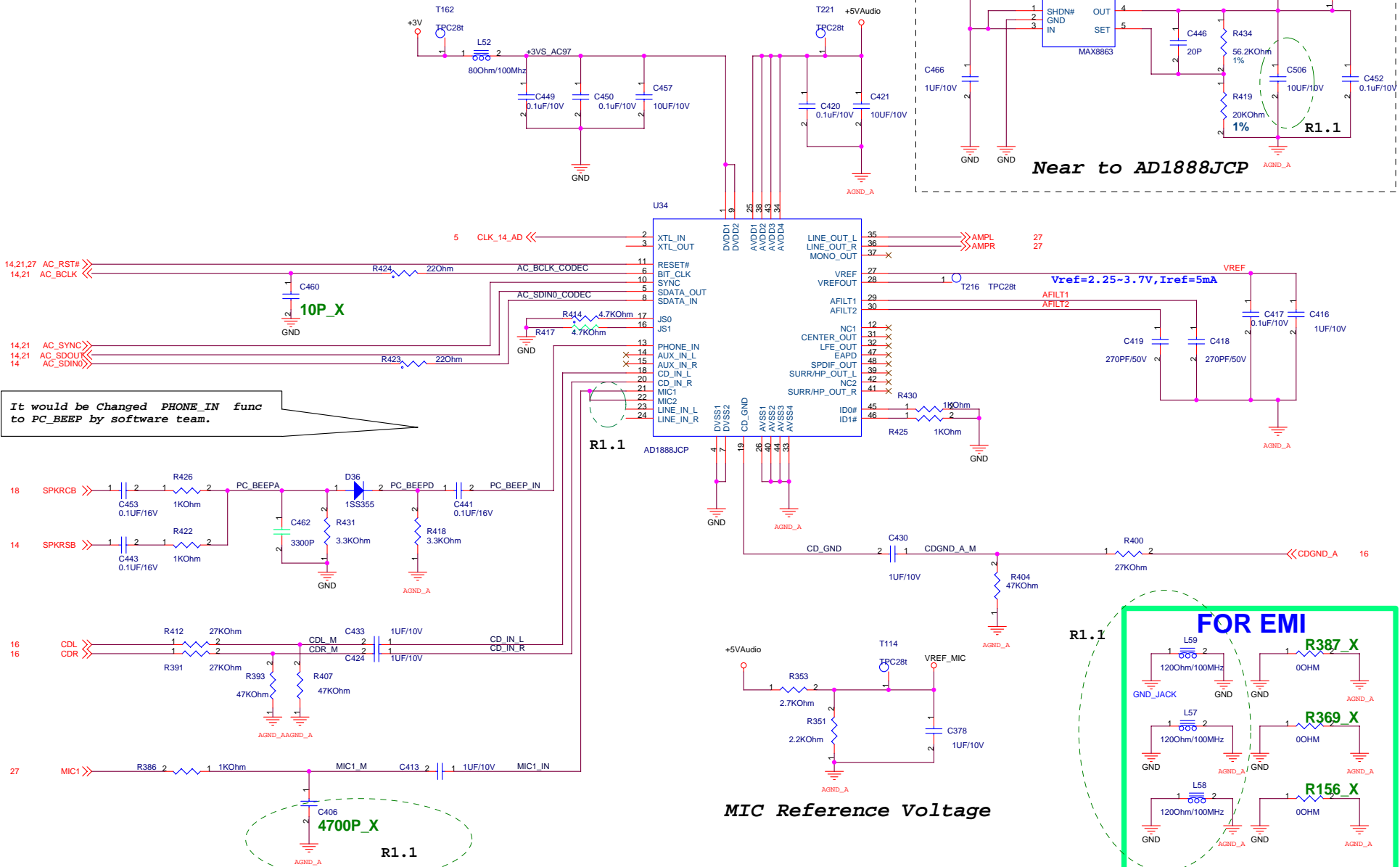

It would be changed PHONE_IN func to PC_BEEP by software team.

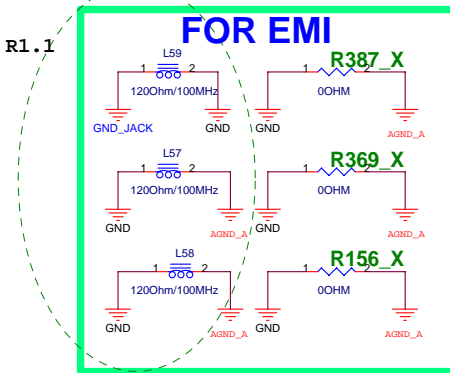

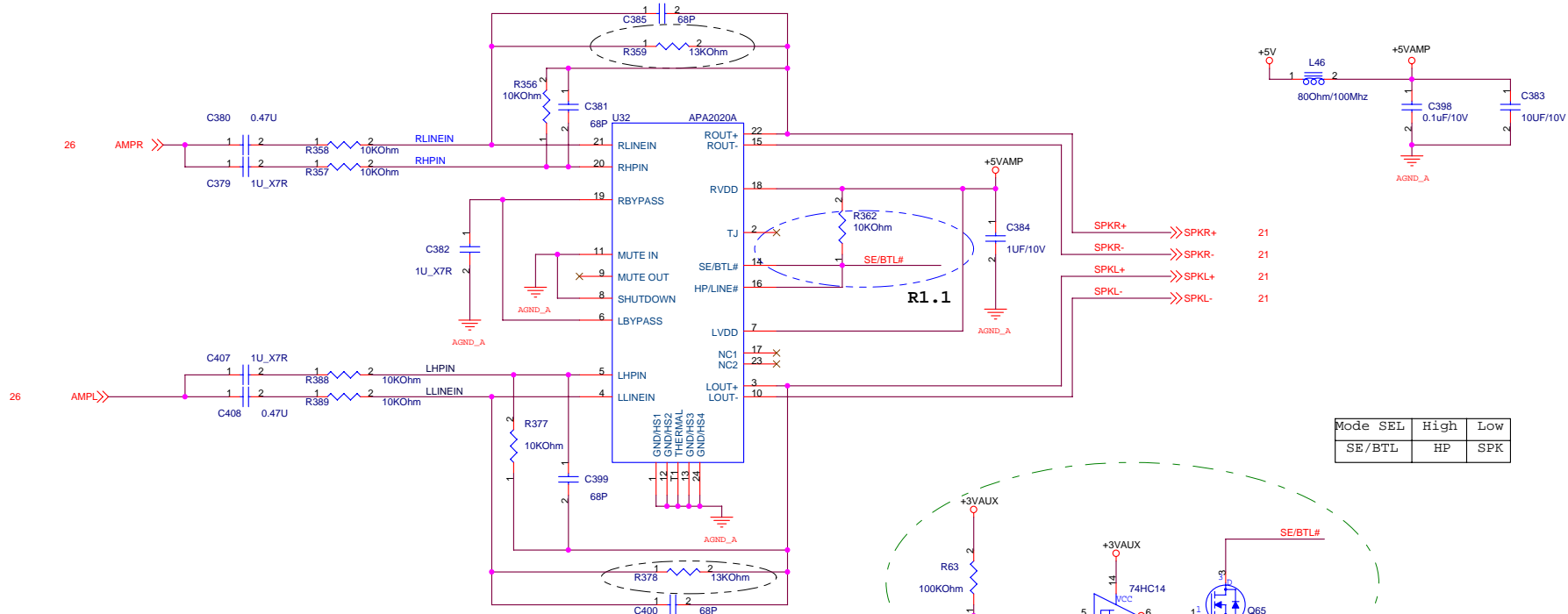

Mode	SEL	High	Low
SE/BTL		HP	SPK

TO PREVENT POP SOUND WHEN SYSTEM WAKE UP FROM S3

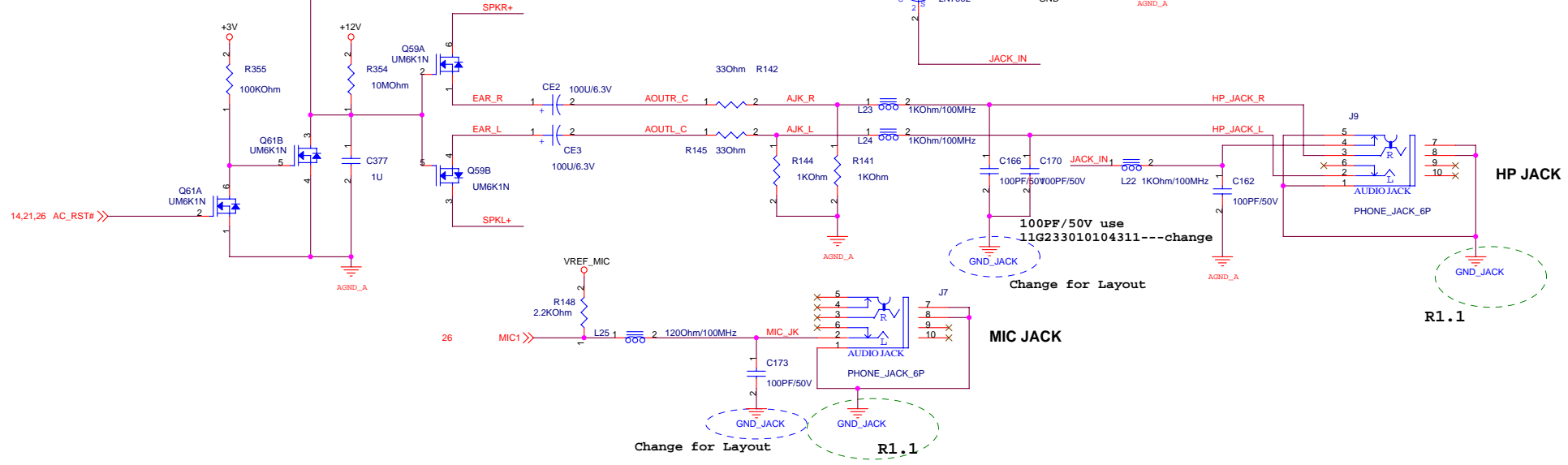

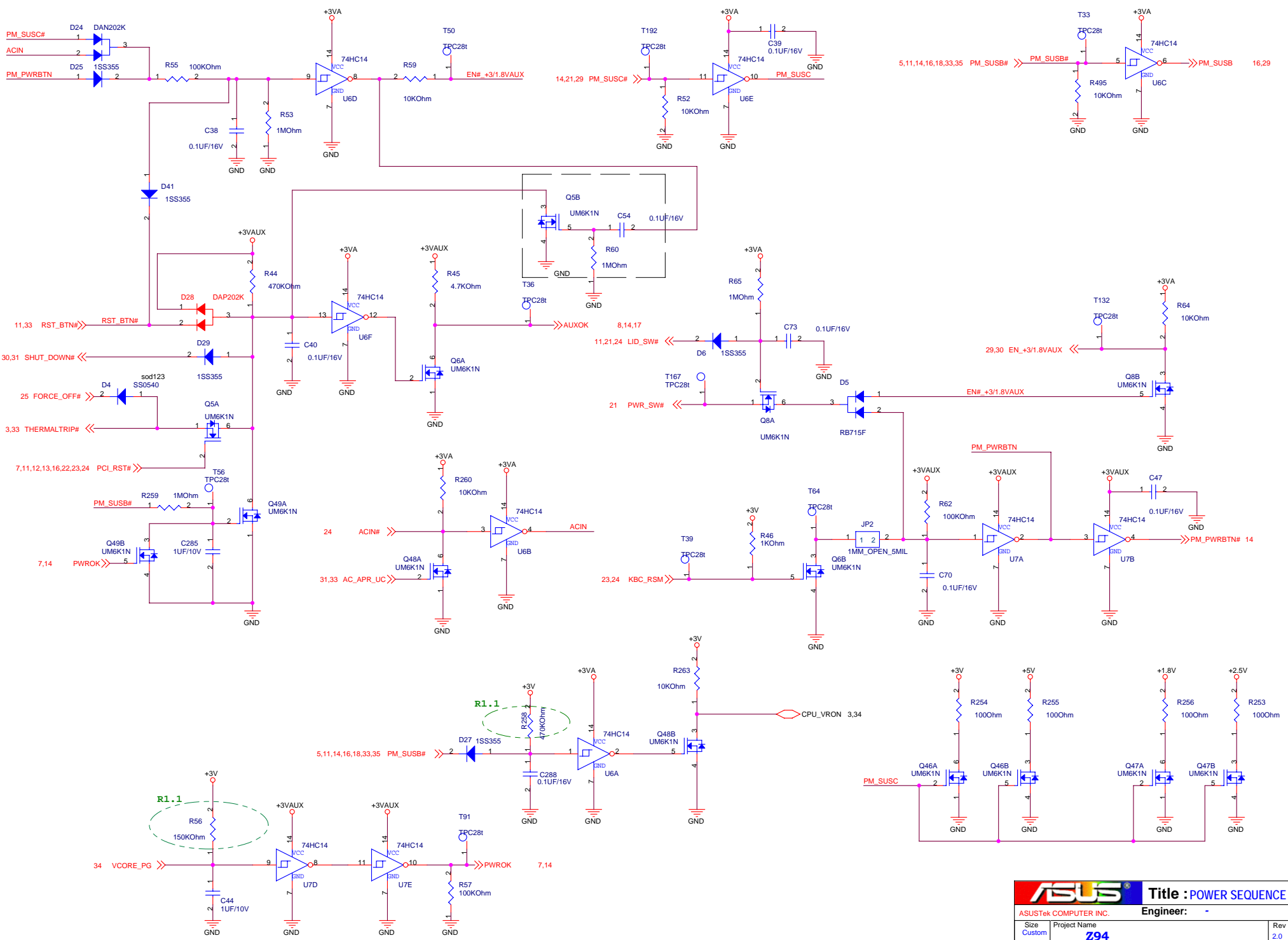

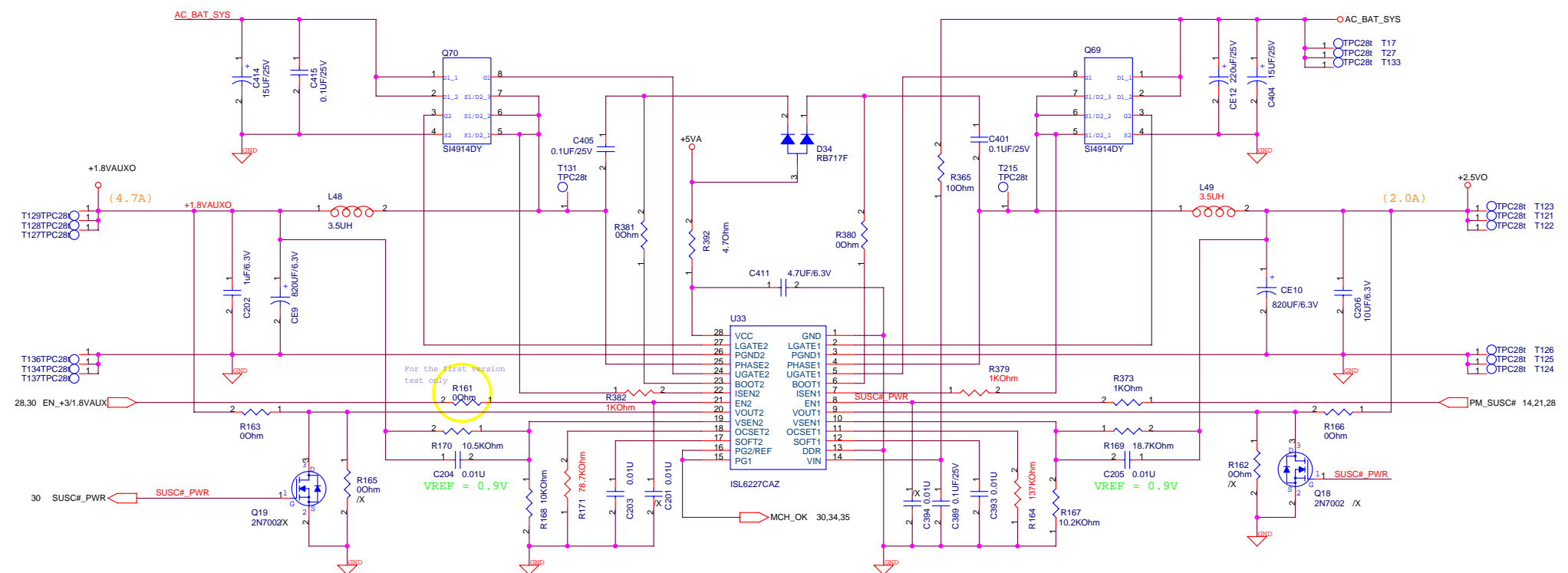

For the first version test only

VRREF = 0.9V

VRREF = 0.9V

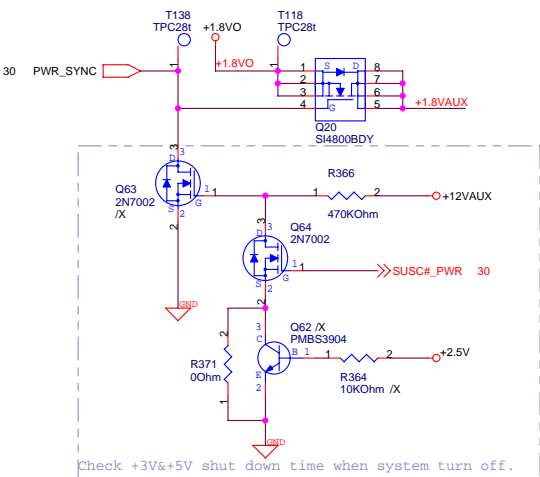
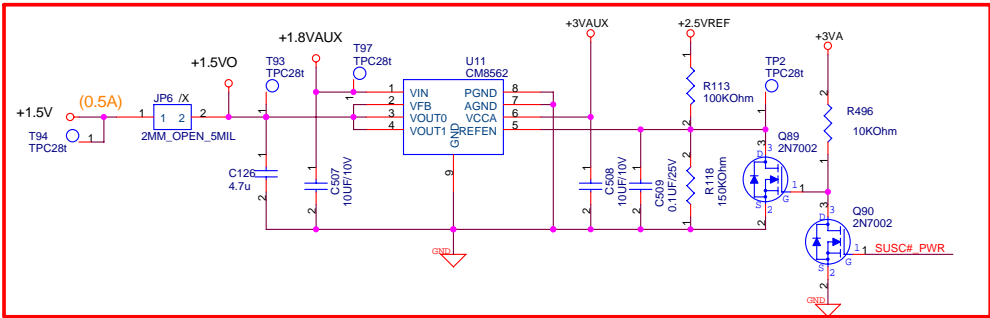

Check +3V/+5V shut down time when system turn off.

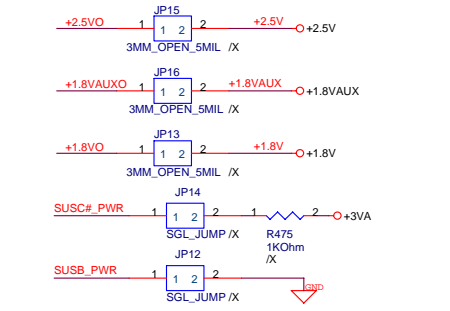
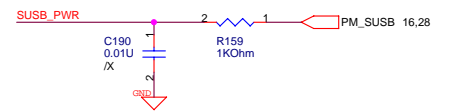

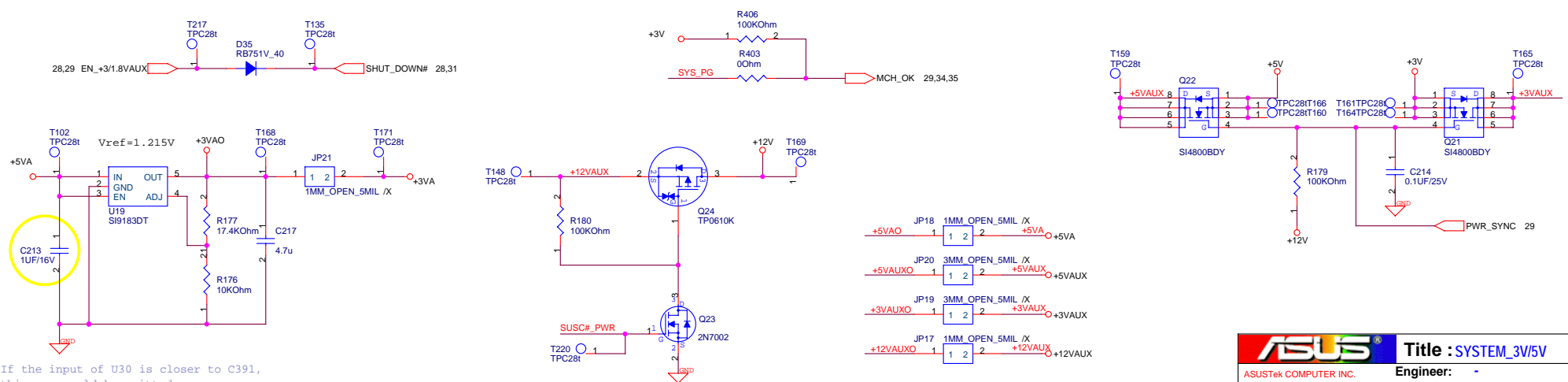
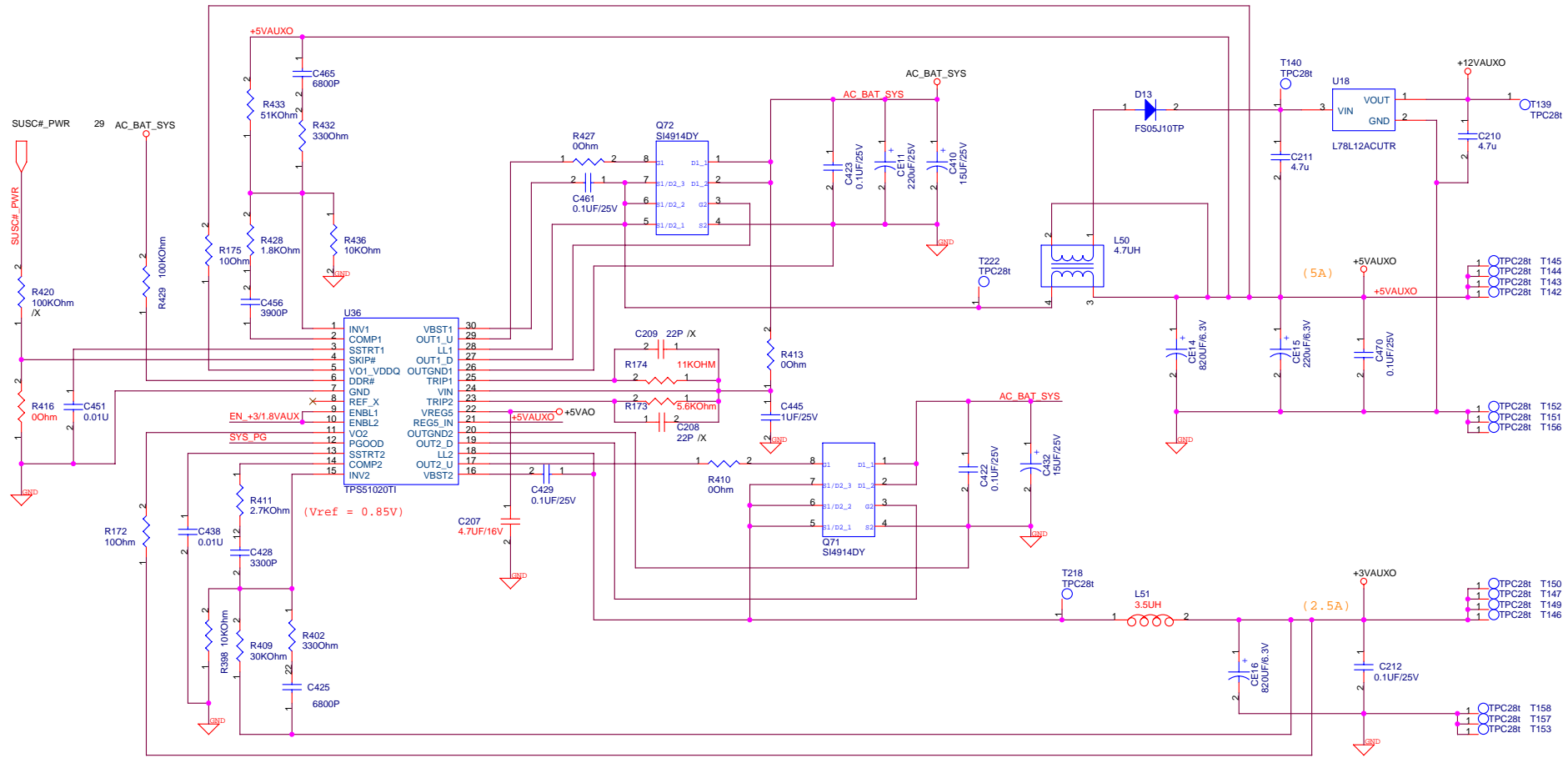

If the input of U30 is closer to C391, this cap could be omitted.

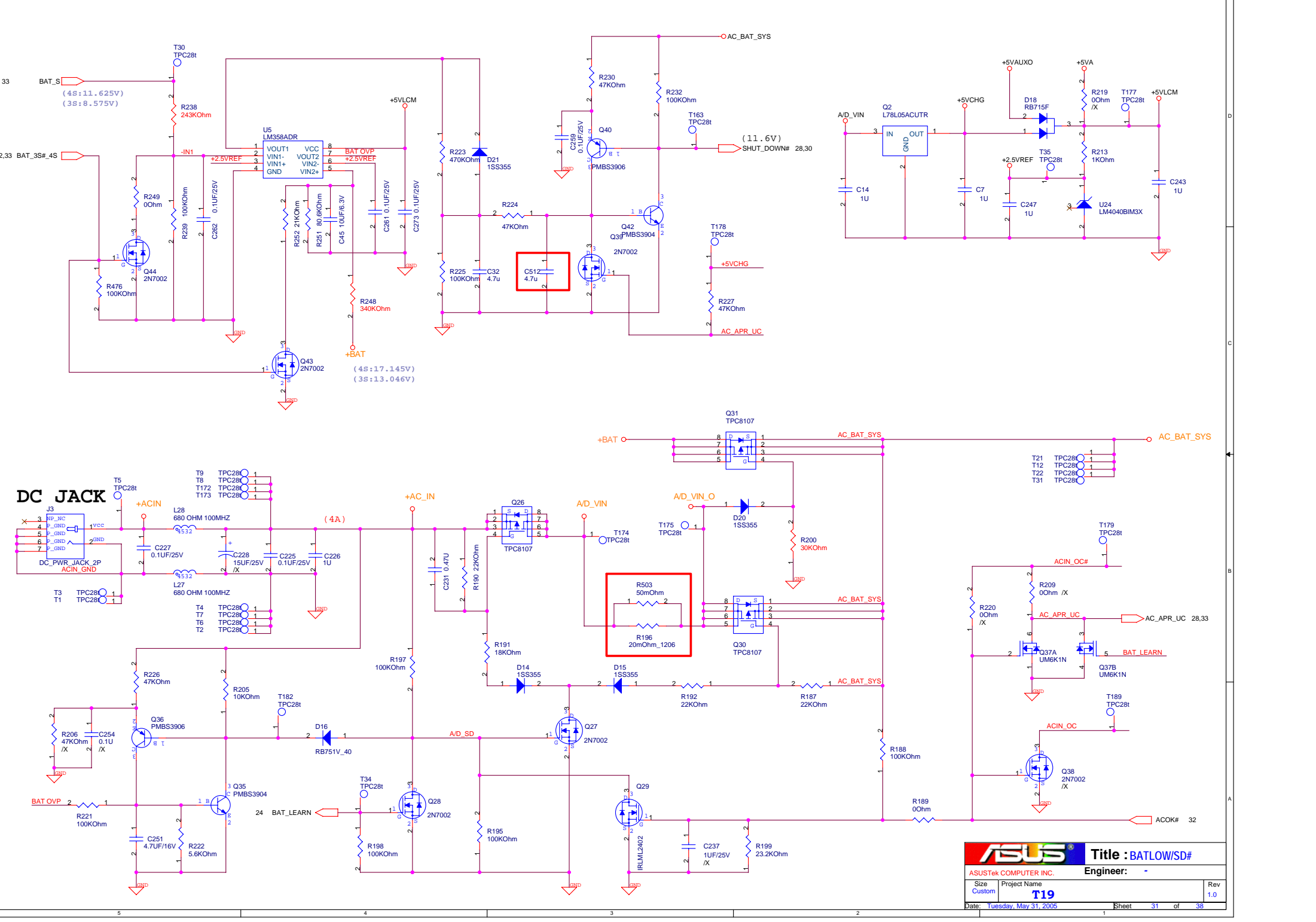

DC JACK

ASUS		Title : BATLOW/SD#	
ASUSTek COMPUTER INC.		Engineer: -	
Size Custom	Project Name T19	Date: Tuesday, May 31, 2005	Rev 1.0
		Sheet 31	of 38

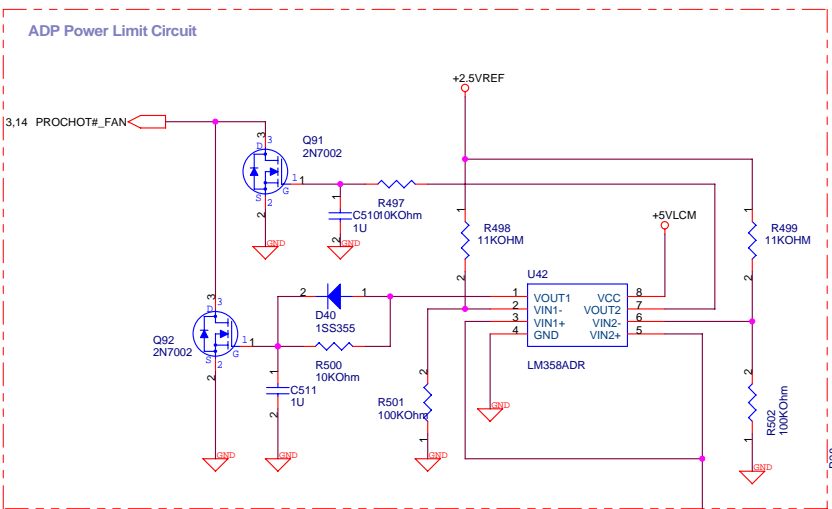

ACOK#:
 $+ACIN \geq 2V * (R25 + R26) / R26$
 $= 2 * (107 + 13.7) / 13.7 = 17.62$

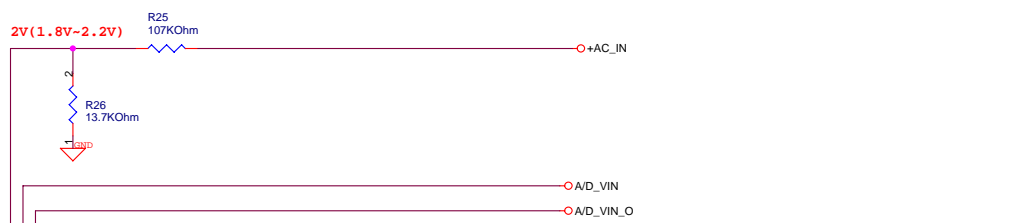

Charge Current Setting
 $V(+INE2) = 25 * I_{chg}(A) * R_{s2}$
 2P# => ICHG=2.5A
 1P => ICHG=1.25A
 Prechg. => ICHG=0.4A

Current sharing = 3.2A
 $V(+INE1) = 25 * I_{chg}(A) * R_{s1}$
 $I = (5 * R27 / (R28 + R27)) / (25 * 50m)$
 $= 3.203A$

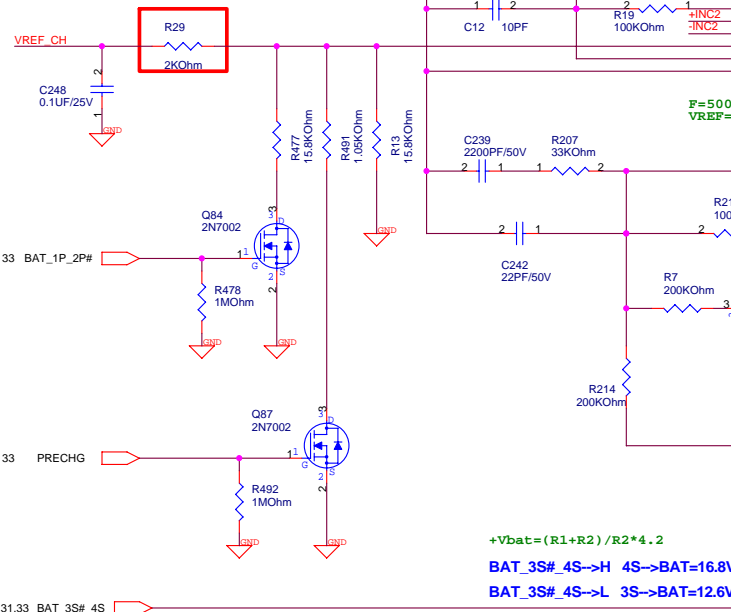

$+V_{bat} = (R1 + R2) / R2 * 4.2$
 BAT_3S#_4S->H 4S->BAT=16.8V
 BAT_3S#_4S->L 3S->BAT=12.6V

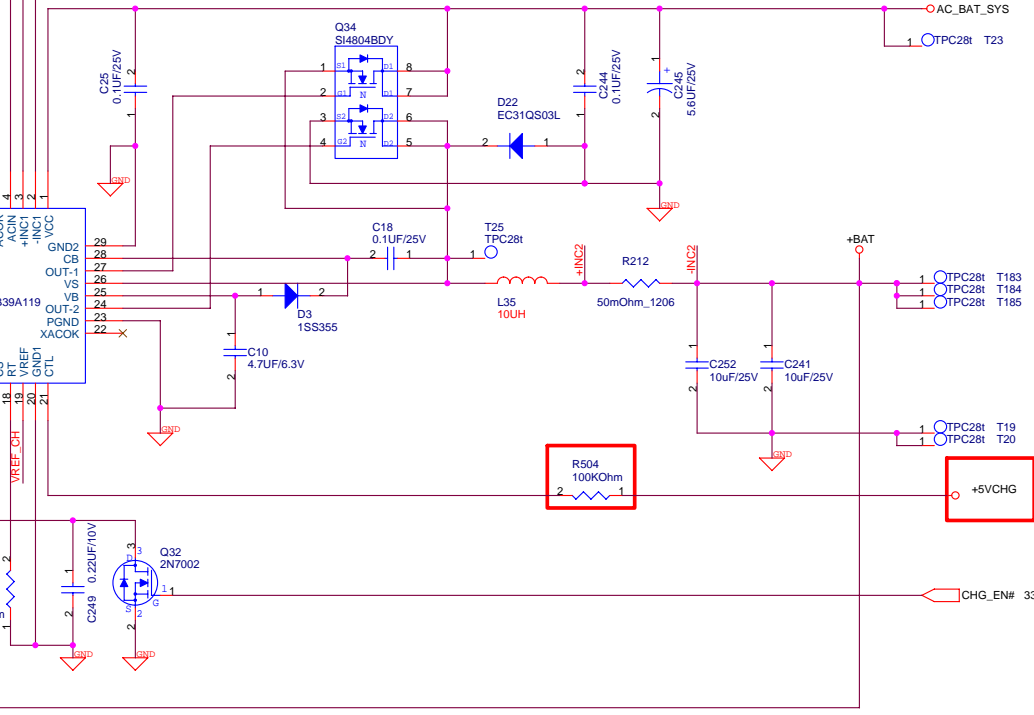

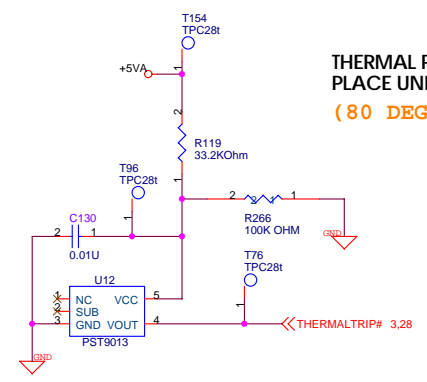
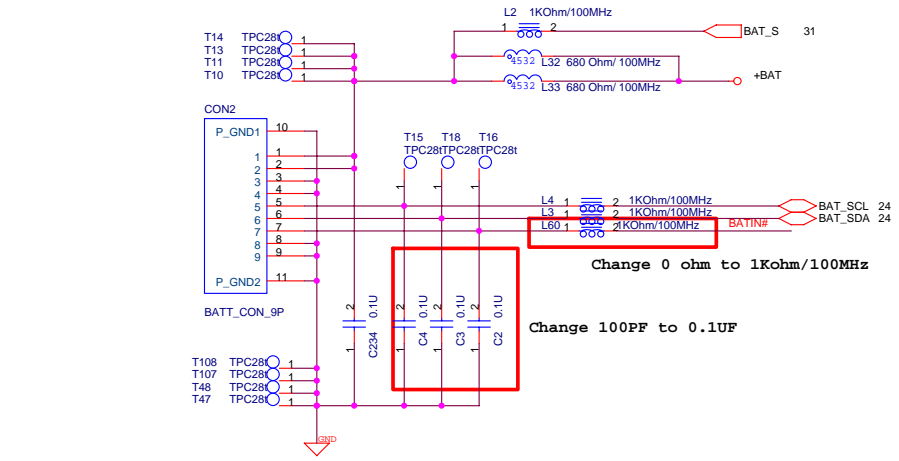
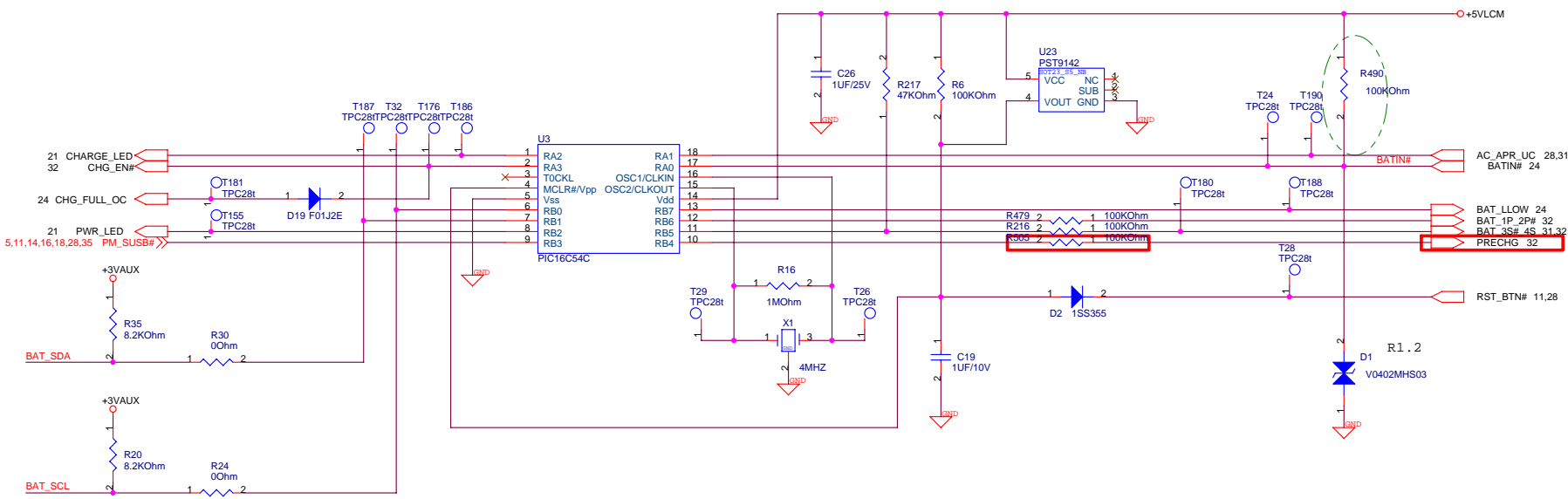

**THERMAL PROTECTION
PLACE UNDER CPU
(80 DEGREE C)**

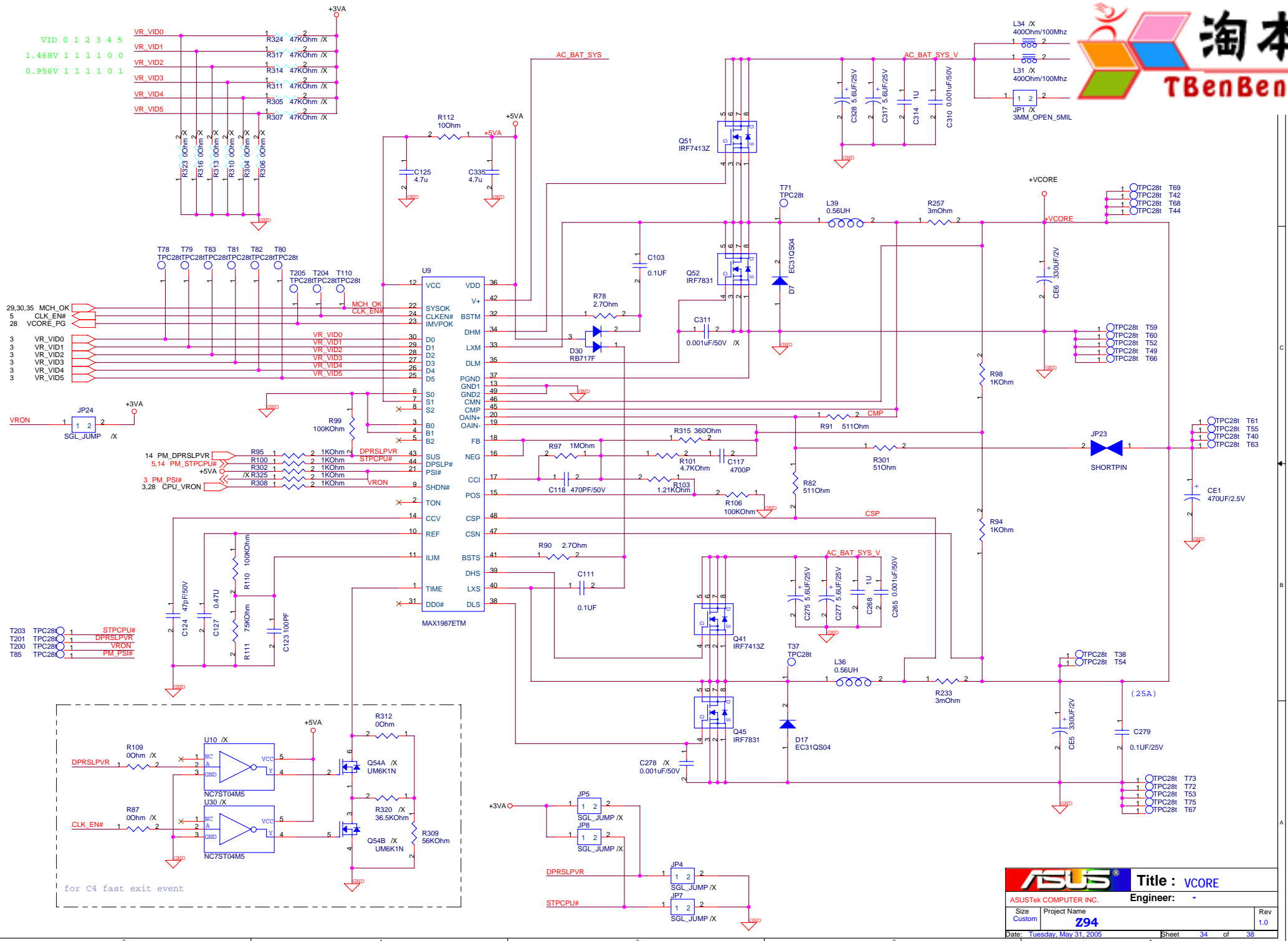

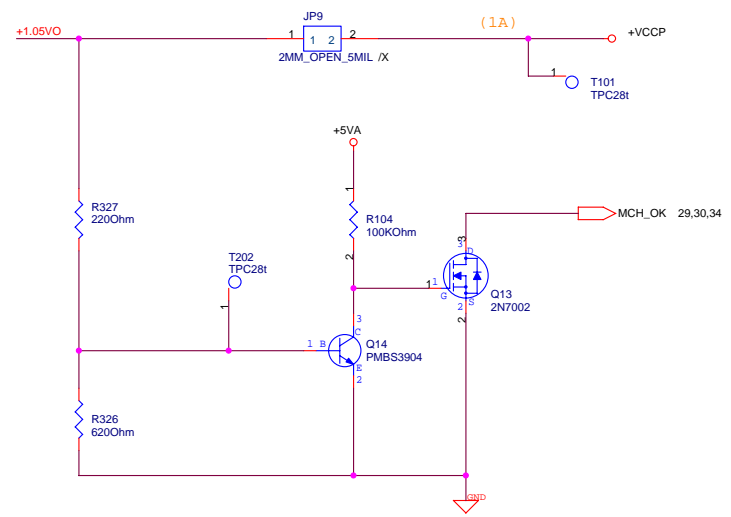
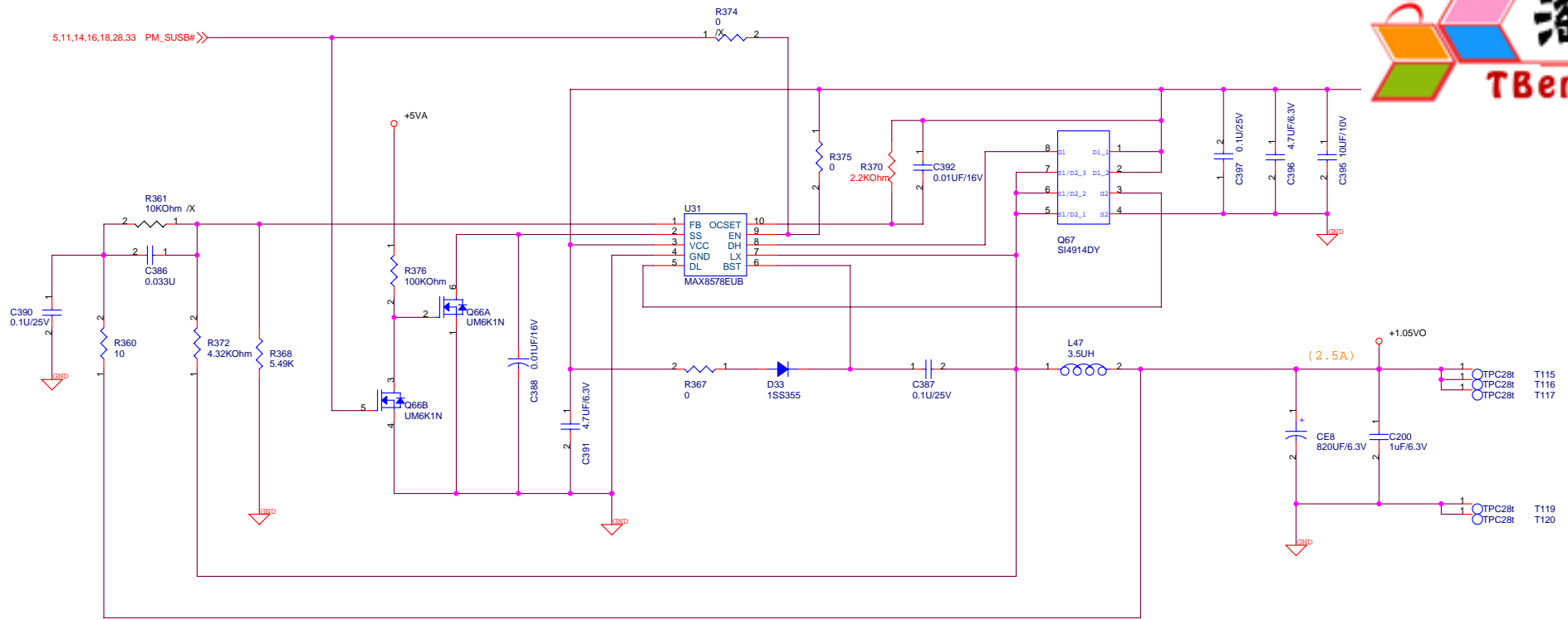

PCI Device	IDSEL#	REQ/GNT#	Interrupts	PC/PCI
Chipset (HOST TO PCI)	(AD11 Internal)			
AGP	(AD16 Internal)		D	
LAN	AD15		D	
HDD	AD13		A	IRQ15
LPC	AD13		C	
MODEM	AD13		C	
AUDIO	AD13		C	
USB	AD14		E,F,G,H	
CardBus	AD19		B,C,D	
ODD	AD13			IRQ14
1394	AD19		B,C,D	



KBC GPIO USE AS				
Pin Name	Function	Signal Name	Default	S3/!
P20	NC			
P21	GPI		Low	
P22	GPO	BAT_LEARN	Low	Low
P23	NC			
P24	GPO	SET_PCIRSTNS	Low	High
P25	LEDCAP	CAPS_LED#	High	High
P26	LEDNUM	NUM_LED#	High	High
P27	SCROLL	SCROLL_LED#	High	High
P40	GPO	EMT_SMI	Low	Low
P41	GPO	EMAIL_LED	Low	Low
P42	NC			
P43	GPI	PM_LID#	High	High
P44	NC			
P45	GPI	KEY_ID0		
P46	SCI	KBC_SCI#		
P47	CLKRUN#	PM_CLKRUN#		
P50	GPO	KBC_RSM	Low	Low
P51	NC			
P52	GPI	KEY_ID1		
P53	NC			
P54	NC			
P55	GPI	BAT_LLOW		
P56	NC			
P57	GPO	BACKLIGHT_DA	anlog	anlog
P60	GPI	P4G_SW#		
P61	GPI	INTERNET_SW#		
P62	GPI	CHG_FULL_OC	Low	
P63	GPI	EMAIL_SW#		
P64	GPI	ACIN_SIS964	Low	
P65	GPO	FWH_WP#	High	High
P66	GPI	BATIN#_KBC	High	
P67	GPI	DIS_TP#		

SIS964 GPIO USE AS		
Pin Name	Function	Signal Name
GPIO0	GPI	PACCESS_EN#
GPIO1	GPI	AGP_8XDET#
GPIO2	THERM#	PROCHOT#_FAN
GPIO3	EXTSMI#	EXT_SMI#
GPIO4	CLKRUN#	PM_CLKRUN#
GPIO5	NC	
GPIO6	GPI	THERM#
GPIO7	GPI	ODD_CLR
GPIO8	RING	RIA#
GPIO9	GPI	KBC_SCI#
GPIO10	GPI	SIO_SMI#
GPIO11	STP_PCI#	PM_STPPCI#
GPIO12	CPUSTP#	PM_STPCPU#
GPIO13	DPRSLPVR	PM_DPRSLPVR
GPIO14	AGPSTOP#	AGPSTOP#
GPIO15	VR_HILO#	VR_HI/LO#
GPIO16	NC	
GPIO17	VGATEM#	VGATEM#
GPIO18	NC	
GPIO19	SMC	SMC
GPIO20	SMD	SMD
GPIO21	NC	
GPIO22	NC	
GPIO23	NC	
GPIO24	NC	

SUPER I/O ITE8712F GPIO USE AS				
Pin Name	Function	Signal Name	Default	S3/S4
GPIO10	GPO	SIOSMI#	High	
GPIO11	NC			
GPIO12	NC			
GPIO13	NC			
GPIO14	NC			
GPIO15	NC			
GPIO16	NC			
GPIO17	NC			
GPIO20	NC			
GPIO21	NC			
GPIO22	NC			
GPIO23	NC			
GPIO24	GPI	PANEL_ID1	High	
GPIO25	GPO	BACK_OFF#	High	
GPIO26	GPI	PANEL_ID1	High	
GPIO27	GPI	PANEL_ID0	High	
GPIO30	GPO	ODD_CLR	LOW	
GPIO31	GPI	ODD_SET	LOW	
GPIO32	NC			
GPIO33	NC			
GPIO34	NC			
GPIO35	NC			
GPIO36	NC			
GPIO37	NC			
GPIO40	NC			
GPIO41	NC			
GPIO42	NC			
GPIO43	PANSWH#	PANSWH#	High	
GPIO44	NC			
GPIO45	NC			
GPIO46	NC			
GPIO47	NC			
GPIO50	CLKRUN#	PM_CLKRUN#		
GPIO51	FAN_CLT2	SIO_VGA_FAN_PWM		
GPIO52	FAN_TAC2	FAN_TACH		
GPIO53	NC			
GPIO54	PME#	PCI_PME#		
GPIO55	NC			

SM BUS Address		
BUS name	Address	Device
Thermal controller	2E	ADT7460ARQ
Clock GEN	D2	ICS950816
DDR Clock	D4	ICS93732

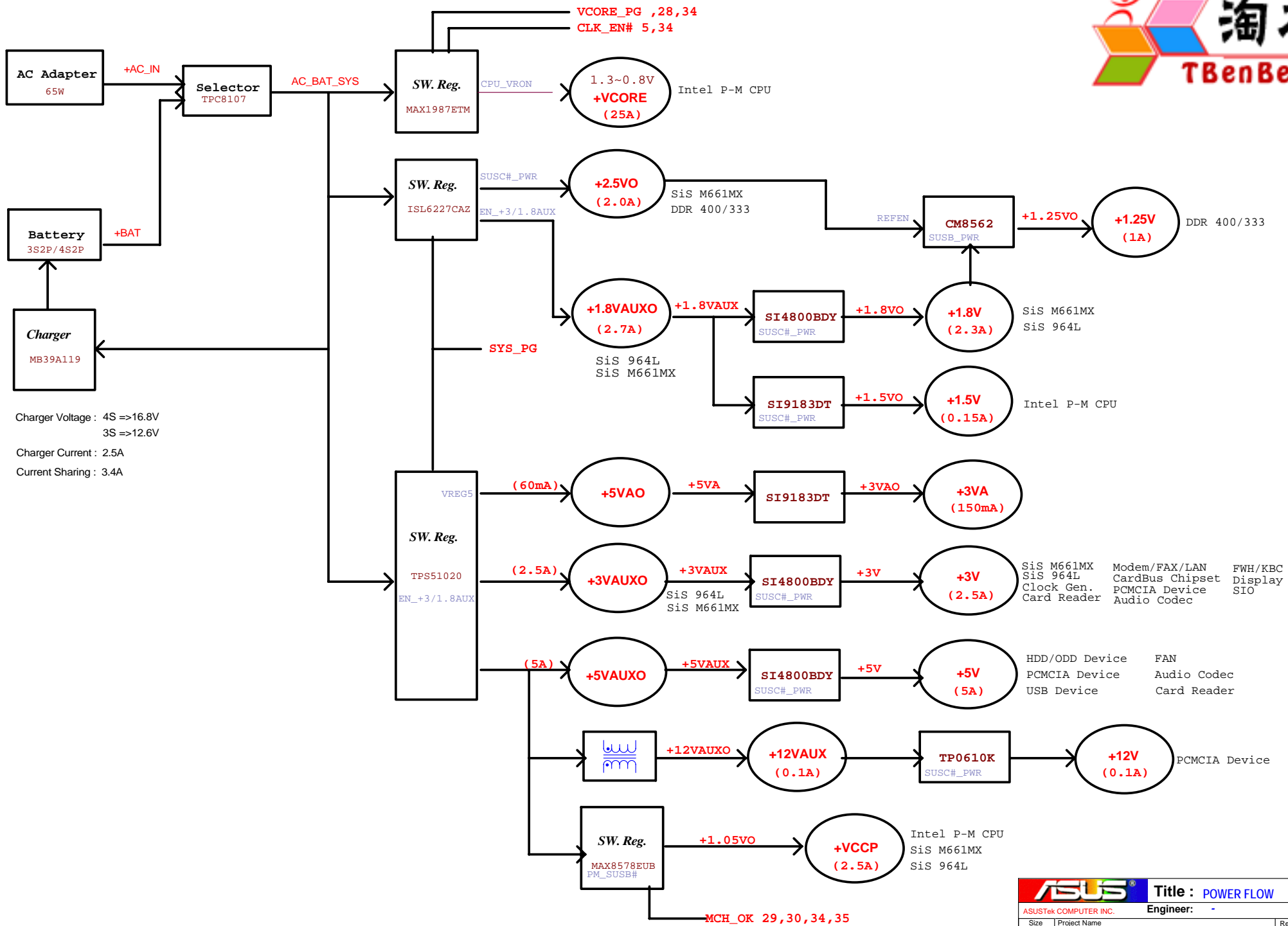

Charger Voltage : 4S =>16.8V
 3S =>12.6V
 Charger Current : 2.5A
 Current Sharing : 3.4A

- 1.change page3 R10 from 20K 5% to 20K 1%.
- 2.page5 change R335,R328,R334 from 0 ohm to 33 ohm and delete C347,C349,C351,C354 5P capacitor.
- 3.Change page5 BSEL circuit
- 4.Page6 AGP_VREF add AGP bus reference voltage R465,R466 with 2.32 ohm 1%
- 5.Page6 AGP_8XDET# cancel connect(pull high only)
- 6.Page11 add AGP_8XDET# R493 pull high 3V.
Add net RST_BTN.
- 7.Page14 change RXD0 damp resistor near to U4 source.
- 8.Page 14 change ACIN_SIS964 to KBC GPIO64.
- 9.Page 14 change BATIN# to KBC GIP066
- 10.Page 14 change SIO_SMI# from SIS964 GPIO16 to GPIO10.
- 11.Page 14 add SIS964 GPIO7 pull high
- 12.Page 14 change CHG_FULL_OC from SIS964 GPIO18 to KBC GPIO62.
- 13.Page 14 change PM_LID# from SIS964 GPIO7 to KBC GPIO43.
- 14.Page 15 SIS964 UVDD33_1~3 power change to USBCOMPVDD.
- 15.Page 16 add ESD protection D42,D43
- 16.Page 17 RJ45 LAN pin difine inverse
- 17.Page 20 change R262 from 10K to 100K ohm to reduce delay time.
- 18.Page 21 add MOS to switch +5V ensure +5V will not sink current when USB device plug in.
- 19.Page 22 change R456 from 1.3K to 330 ohm..
- 20.Page 23 add TPM solution..
- 21.Page 24 add MUTI function EMAIL_LED and SCROLL_LED.
- 22.Page 24 add KBC pin24 to GND for KBC select.
- 23.Page 26 change from TAN_capacitor to ceramic.
- 24.Page 27 change SE/BTL select.
- 25.Page 26 add CODEC pin 22(MIC2) conect pin 21
- 26.Page 28 change R258 from 100K to 470K for power sequence.
- 27.Page 28 change R258 from 10K to 150K for power sequence.
- 28.Page 27 Jack GND net change to GND_JACK for EMI
- 29.Page 26 add L57,L58,L59 for EMI
- 30.Page 26 add L57,L58,L59 for EMI
- 31.Page 21 change CPU hole H4,H5,H6,H7 NPTH to PTH and add J10 spring for EMI
- 32.Page 21 add FUSE F2 and L53,L54,L55,L56 change to 600ohm/100MHz
- 33.Page 21 change CPU hole H4,H5,H6,H7 NPTH to PTH and add J10 spring for EMI
- 34.Page 3 Q4 N-MOSFET change to drain connect R31 pin1 source connector GND
- 35.Page 5 Change C316,C413 from 12PF to 33PF
- 36.Page 14 Change C175,C179 from 18PF to 15PF