

Z84J

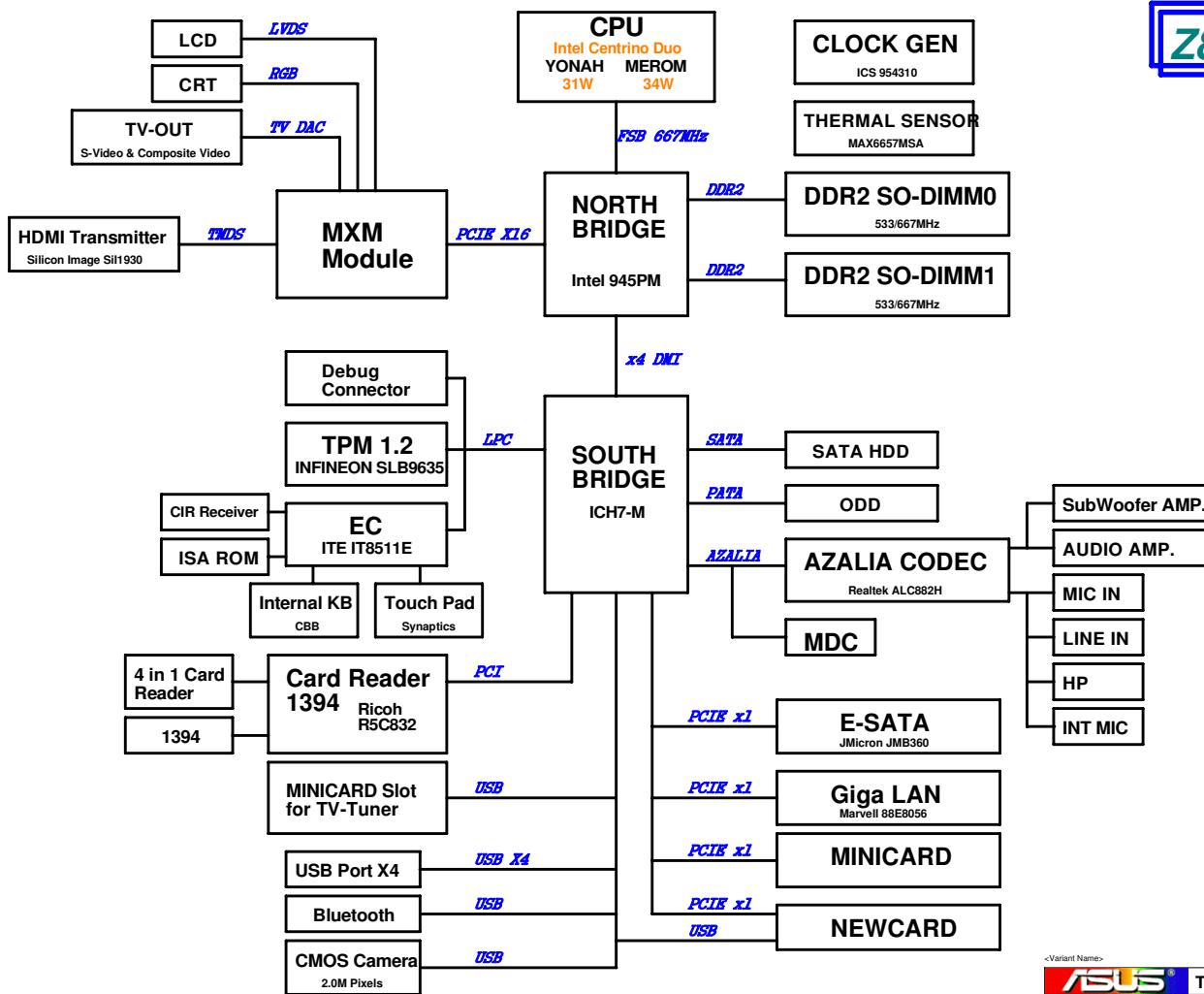

<Variant Name>

ASUS		Title : Block Diagram	
ASUSTek Computer INC.		Engineer: Jack Hsu	
Size	Project Name		Rev
Custom	Z84J		1.1
Date: 10/10/2009		Sheet: 1	of 68

<< Kennedy_Zhang >>

EC GPIO SETTING

Pin	Pin Name	Signal Name	Type
32	PWM0/GPA0	BL_PWM_DA	O
33	PWM1/GPA1	FAN_PWM	O
36	PWM2/GPA2	CLK_PWRSERVE#	O
37	PWM3/GPA3	/	O
38	PWM4/GPA4	CHG_LED_UP#	O
39	PWM5/GPA5	PWR_LED_UP#	O
40	PWM6/GPA6	/	O
43	PWM7/GPA7	LCD_BACKOFF#	O
153	RXD/GPB0	NUM_LED	O
154	TXD/GPB1	CAP_LED	O
162	GPB2	SCRL_LED	O
163	SMCLK0/GPB3	SMB0_CLK	IO
164	SMDAT0/GPB4	SMB0_DAT	IO
5	GA20/GPB5	A20GATE	O
6	KBRST#/GPB6	RC_IN#	O
165	GPB7	/	O
47	CLKOUT/GPC0	/	O
169	SMCLK1/GPC1	SMB1_CLK	IO
170	SMDAT1/GPC2	SMB1_DAT	IO
171	GPC3	Mail_LED	O
172	TMR0/WUI2/GPC4	AC_OK#	I
175	GPC5	OP_SD#	O
176	TMR11/WUI3/GPC6	BAT_IN_OC#	I
1	CK32KOUT/GPC7	/	O
26	RH1#WUI0/GPD0	SUSB#	I
29	R2#WUI1/GPD1	SUSC#	I
30	LPCRST#WUI4/GPD2	PLT_RST#	I
31	ECSC#GPD3	EXT_SC#	O
41	GPD4	/	O
42	GINT/GPD5	/	O
62	TACH0/GPD6	FAN0_TACH	I
63	TACH1/GPD7	/	O
87	ADC4/GPE0	EMAIL_SW#	I
88	ADC5/GPE1	INTERNET#	I
89	ADC6/GPE2	PWR4G_SW#	I
90	ADC7/GPE3	DISTP_SW#	I
2	PWR5W/GPE4	PWR_SW#	I
44	WUI5/GPE5	/	O
24	LPCPD#WUI6/GPE6	LID_EC#	I
25	CLKRUN#WUI7/GPE7	/	O
110	PS2CLK0/GPF0	/	O
111	PS2DAT0/GPF1	/	O
114	PS2CLK1/GPF2	/	O
115	PS2DAT1/GPF3	/	O
116	PS2CLK2/GPF4	TP_CLK	IO
117	PS2DAT2/GPF5	TP_DAT	IO
118	PS2CLK3/GPF6	/	O
119	PS2DAT3/GPF7	/	O
113	FA16/GPG0	FA16	O
112	FA17/GPG1	FA17	O
104	FA18/GPG2	FA18	O
103	FA19/GPG3	/	O
3	FA20/GPG4	THRM_CPU#	I
4	FA21/GPG5	/	O
27	LPC80HL/GPG6	PMTHERM#	O
28	LPC80LL/GPG7	AC_APP_UC#	I

Pin	Pin Name	Signal Name	Type
48	GPH0	VSUS_ON	O
54	GPH1	VSUS_GD#	I
55	GPH2	CPUPWR_GD#	I
69	GPH3	PM_PWRBTN#	O
70	GPH4	SUSC_ON	O
75	GPH5	SUSB_ON	O
76	GPH6	CPU_VRON	O
105	GPH7	PM_RSMRST#	O
148	GPI0	ICH7_PWROK	O
149	GPI1	/	O
152	GPI2	MCHOK	I
155	GPI3	CHG_EN#	O
156	GPI4	PRECHG	O
168	GPI5	BAT_LL#	O
174	GPI6	BAT_LEARN	O

PCI Device	IDSEL#	REQ/GNT#	Interrupts
CARD READER	AD17	0	INTB-->INTB
1394	AD17	0	INTA-->INTA
LAN	AD16	REQ#2/GNT#2	INTA-->INTD

SM-Bus Device	SM-Bus Address
Clock Generator	1101001x (D2)
SO-DIMM 0	1010000x (A0)
SO-DIMM 1	1010001x (A2)
Thermal Sensor	0101110x (5C)

ICH7-M GPIO SETTING

Pin	Pin Name	Signal Name	Type	Power_Well	Default
AB18	GPI00/BM_BUSY#	PM_BMBUSY#	I	Core(To:3.3V)	GPI
C8	GPI001/REQ5#	PCI_REQ#5	IO	Core(To:3.3V)	GPI
G8	GPI002/PIRQE#	PCI_INTE#	I(OD)	Core(To:3.3V)	GPI
F8	GPI003/PIRQF#	PCI_INTF#	I(OD)	Core(To:3.3V)	GPI
F7	GPI004/PIRQG#	PCI_INTG#	I(OD)	Core(To:3.3V)	GPI
G7	GPI005/PIRQH#	PCI_INTH#	I(OD)	Core(To:3.3V)	GPI
AC21	GPI006	NC	IO	Core(To:3.3V)	GPI
AC18	GPI007	WLAN_BT_LED_EN#	I	Core(To:3.3V)	GPI
E21	GPI008	EXTSM#	I	SUS(To:3.3V)	GPI
E20	GPI009	SATA_DET#0	IO	SUS(To:3.3V)	GPI
A20	GPI010	WLAN_ON#	O	SUS(To:3.3V)	GPI
B23	SMBALERT#/GPI011	SMB_ALERT#	IO	SUS(To:3.3V)	Native
F19	GPI012	KBC_SC#	I	SUS(To:3.3V)	GPI
E19	GPI013	TP	IO	SUS(To:3.3V)	GPI
R4	GPI014	NC	IO	SUS(To:3.3V)	GPI
E22	GPI015	CB_SD#	IO	SUS(To:3.3V)	GPI
AC22	GPI016	PM_DPRSPLV#	O	Core(To:3.3V)	Native
D8	GPI017/GNT5#	PCI_GNT#5	IO	Core(To:3.3V)	GPO
AC20	GPI018/STP_PCI#	STP_PCI#	O	Core(To:3.3V)	GPO
AH18	GPI019/SATA1GP	NC	O	Core(To:3.3V)	GPI
AF21	GPI020/STP_CPU#	STP_CPU#	O	Core(To:3.3V)	GPO
AE19	GPI021/SATA0GP	NC	IO	Core(To:3.3V)	GPI
A13	GPI022/REQ4#	PCI_REQ#4	IO	Core(To:3.3V)	Native
AA5	LDRQ1#/GPI023	TP	IO	Core(To:3.3V)	Native
R3	GPI024	NC	IO	SUS(To:3.3V)	GPO
D20	GPI025	NC	IO	SUS(To:3.3V)	GPO
A21	GPI026/EL_RSVD	NC	IO	SUS(To:3.3V)	GPO
B21	GPI027/EL_STATE0	PD_DET#	IO	SUS(To:3.3V)	GPO
E23	GPI028/EL_STATE1	NC	IO	SUS(To:3.3V)	GPO
C3	GPI029/OC#5	USB_OC#5	IO	SUS(To:3.3V)	Native
A2	GPI030/OC#6	NEWCARD_OC#	I	SUS(To:3.3V)	Native
B3	GPI031/OC#7	USB_OC#7	IO	SUS(To:3.3V)	Native
AG18	GPI032/CLKRUN#	PM_CLKRUN#	O	Core(To:3.3V)	GPO
AC19	GPI033/AZ_DOCK_EN#	BT_ON#	O	Core(To:3.3V)	GPO
U2	GPI034/AZ_DOCK_RST#	NC	IO	Core(To:3.3V)	GPO
AD21	GPI035	NC	IO	Core(To:3.3V)	GPO
AH19	GPI036/SATA2GP	NC	IO	Core(To:3.3V)	GPI
AE19	GPI037/SATA3GP	PCB_ID0	I	Core(To:3.3V)	GPI
AD20	GPI038	PCB_ID1	I	Core(To:3.3V)	GPI
AE20	GPI039	PCB_ID2	I	Core(To:3.3V)	GPI
A14	GNT4#/GPI048	PCI_GNT#4	IO	Core(To:3.3V)	Native
AG24	GPI049/CPUPWRGD	HL_PWRGD	I	V_CPU_IO	Native

<Variant Name>

		Title : System Setting
ASUSTek Computer INC.		Engineer: Jack Hsu
Size	Project Name	Rev
Custom	Z84J	1.1
Date: 11/11/2006	Sheet: 2	of 68

<< Kennedy_Zhang >>

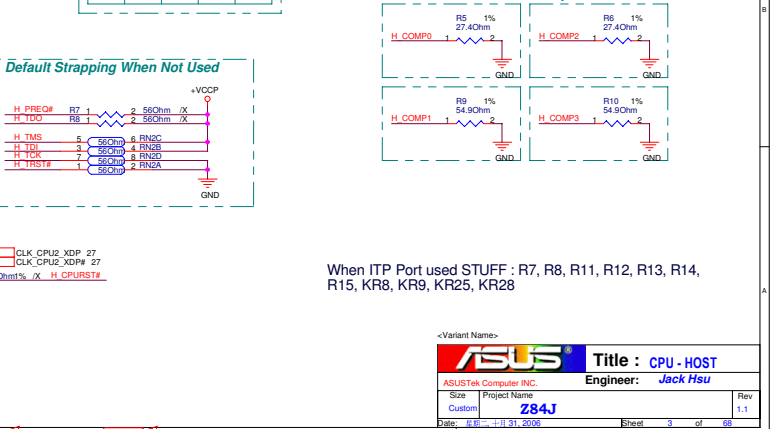
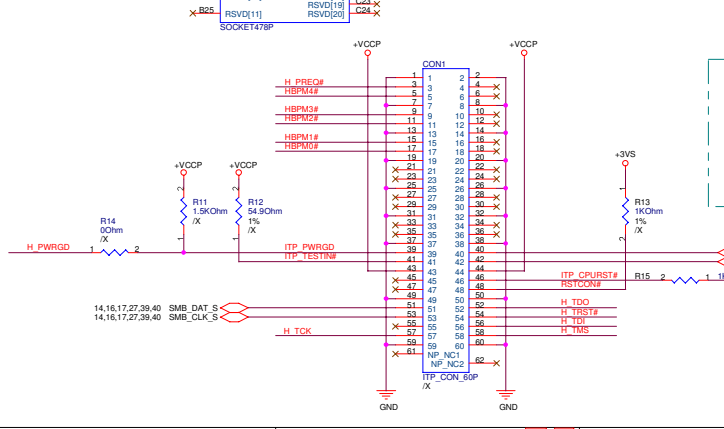
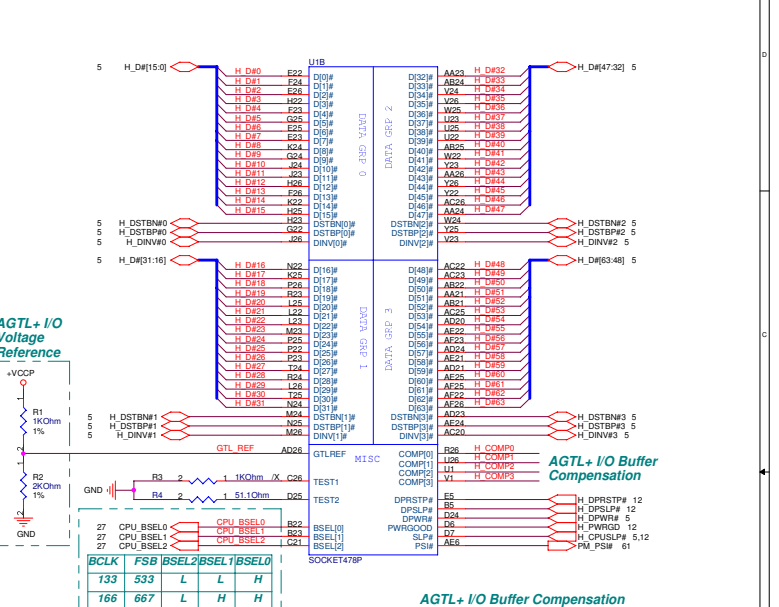
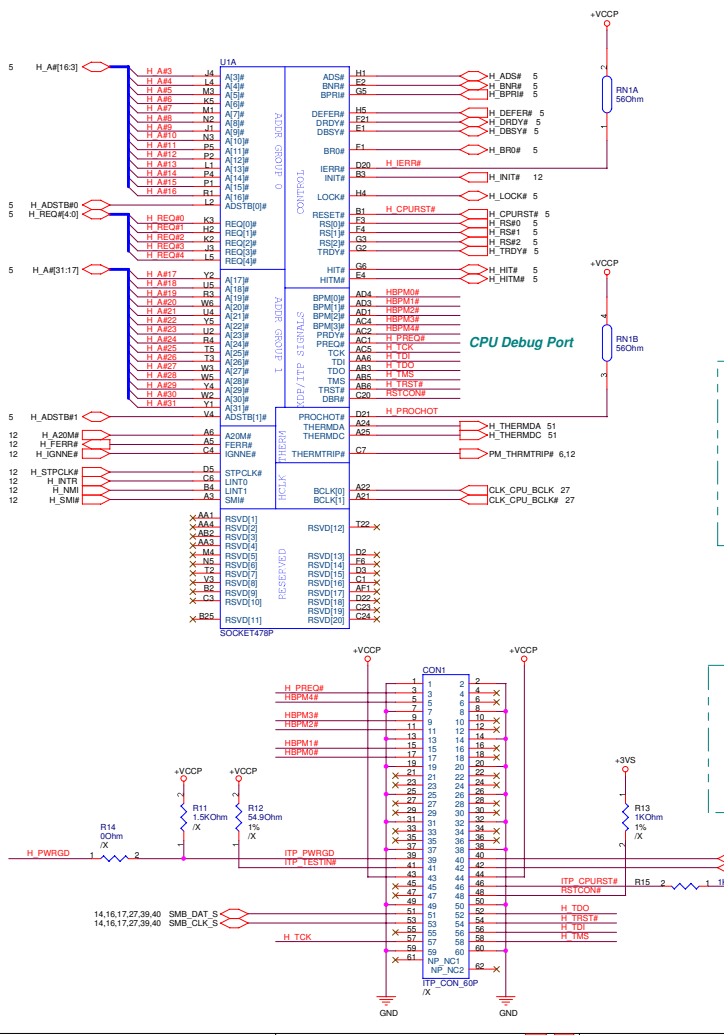

When ITP Port used STUFF : R7, R8, R11, R12, R13, R14, R15, KR8, KR9, KR25, KR28

ASUS
ASUSTek Computer, INC. Title: CPU - HOST
Engineer: Jack Hsu

Size	Project Name	Rev
Custom	Z84J	1.1

Date: 06/11/2006 Sheet: 8 of 88

<< Kennedy_Zhang >>

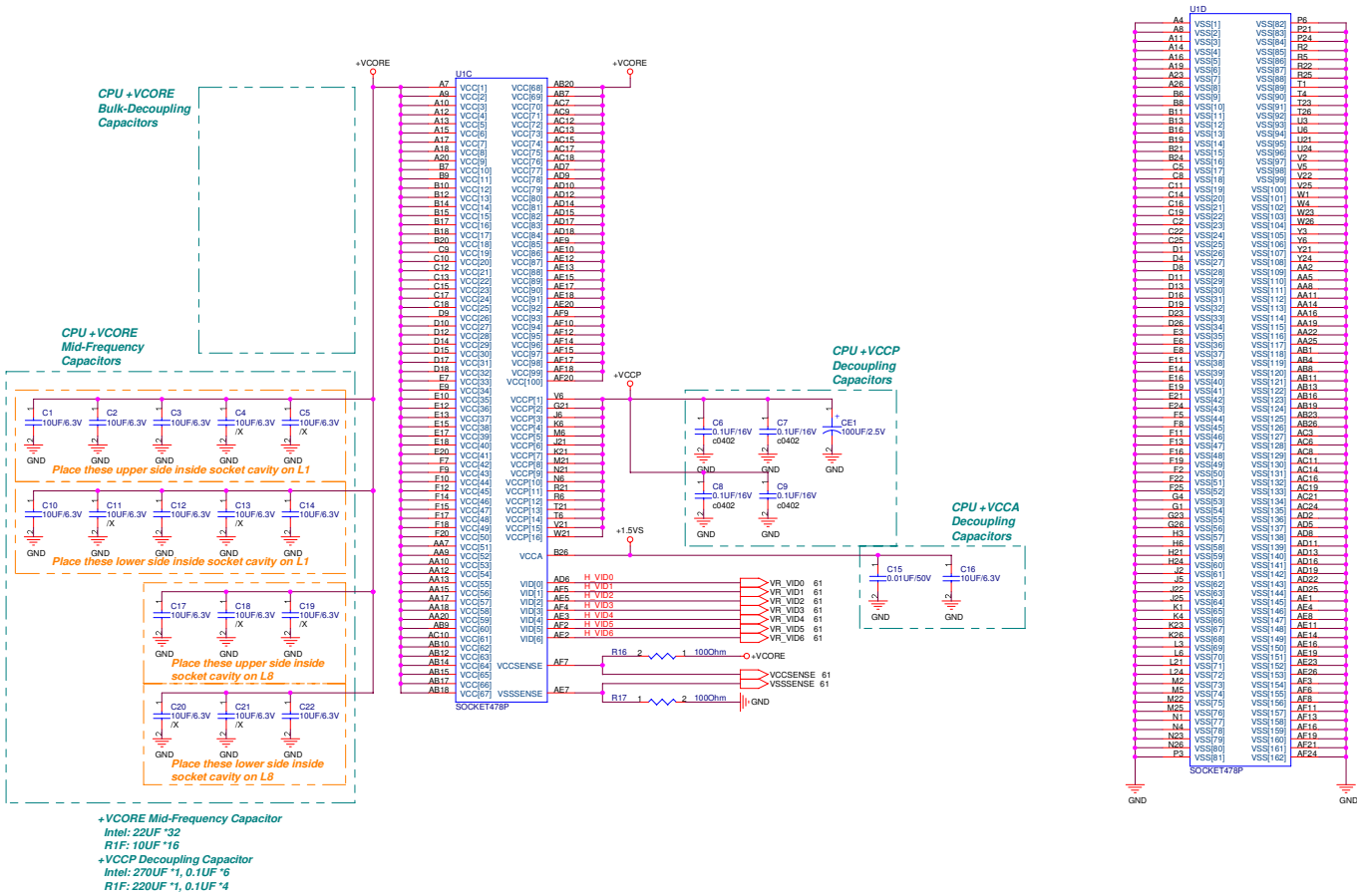

ASUS
ASUSTek Computer INC. **Title : CPU - PWR & GND**
Engineer: Jack Hsu

Size	Project Name	Rev
Custom	Z84J	1.1
Date: 01/31/2006	Sheet: 4	of 08

<< Kennedy_Zhang >>

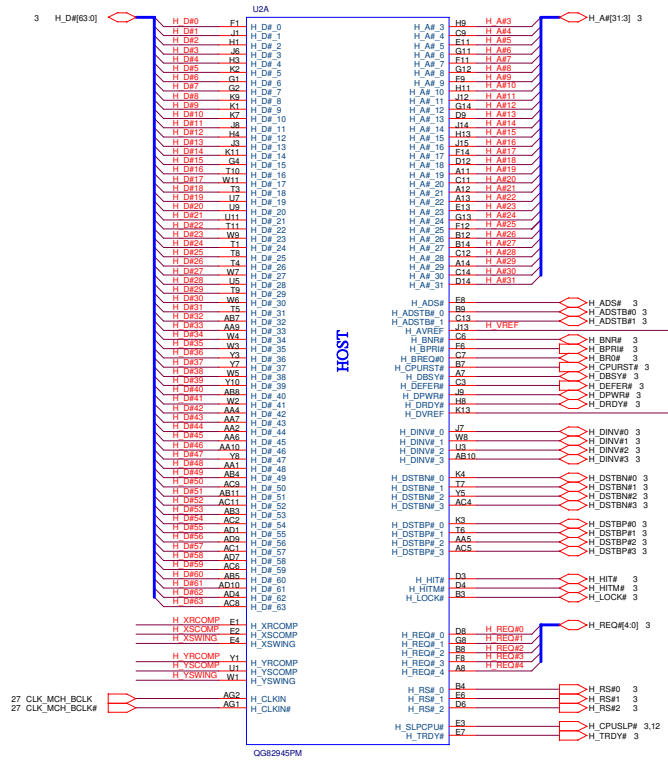
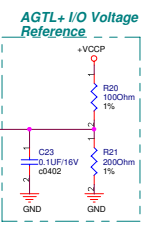
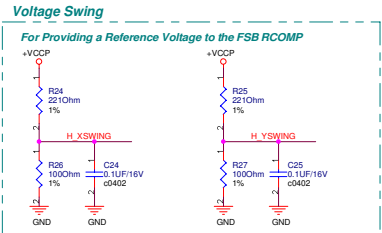
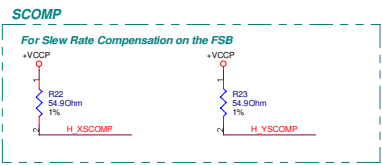
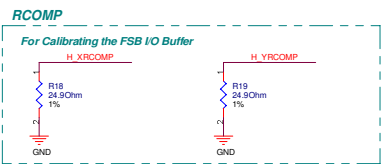

ASUS
ASUSTek Computer, INC. Title : NB_945PM_HOST
Engineer: Jack Hsu

Size	Project Name	Rev
Custom	Z84J	1.1
Date: 11/11/2006	Sheet: 6	of 66

<< Kennedy_Zhang >>

GMCH Strapping

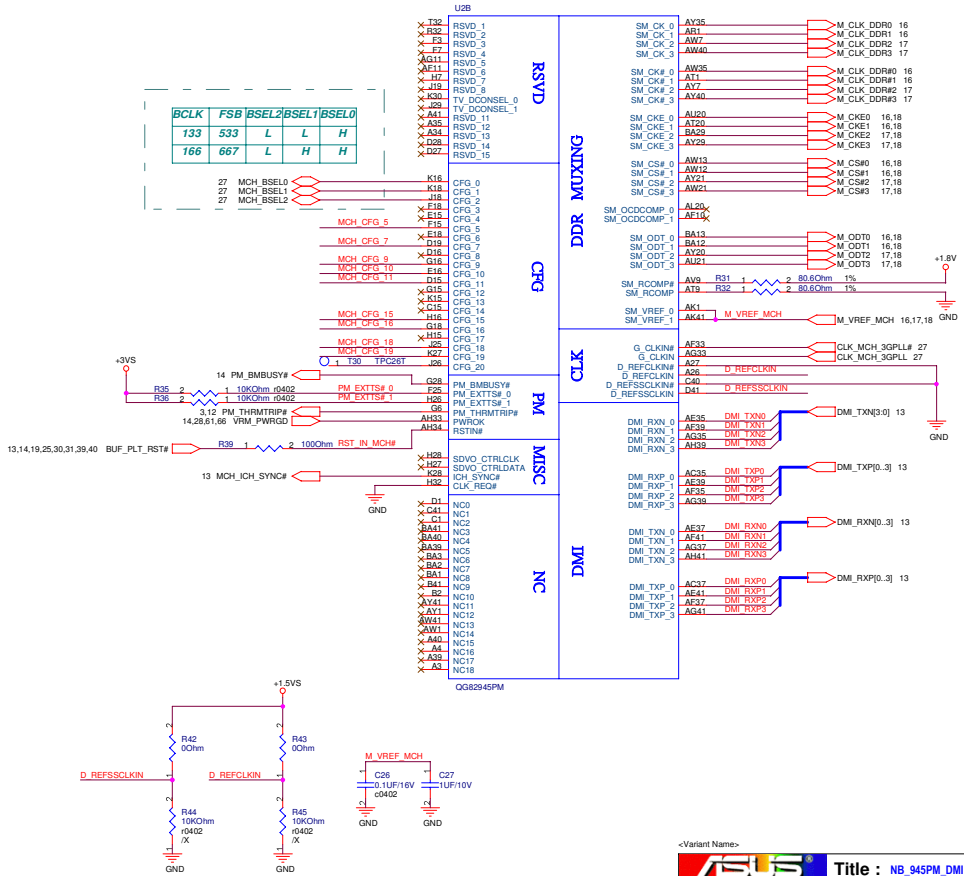
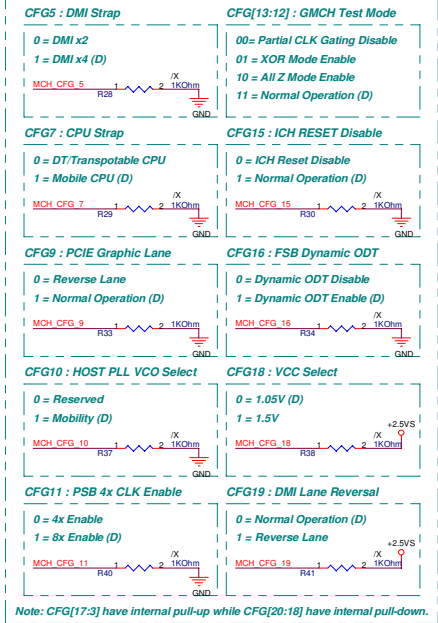

ASUS
 ASUSTek Computer INC.
 Title : NB_945PM_DMI & CFG
 Engineer : Jack Hsu
 Project Name : Z84J
 Rev : 1.1

<< Kennedy_Zhang >>

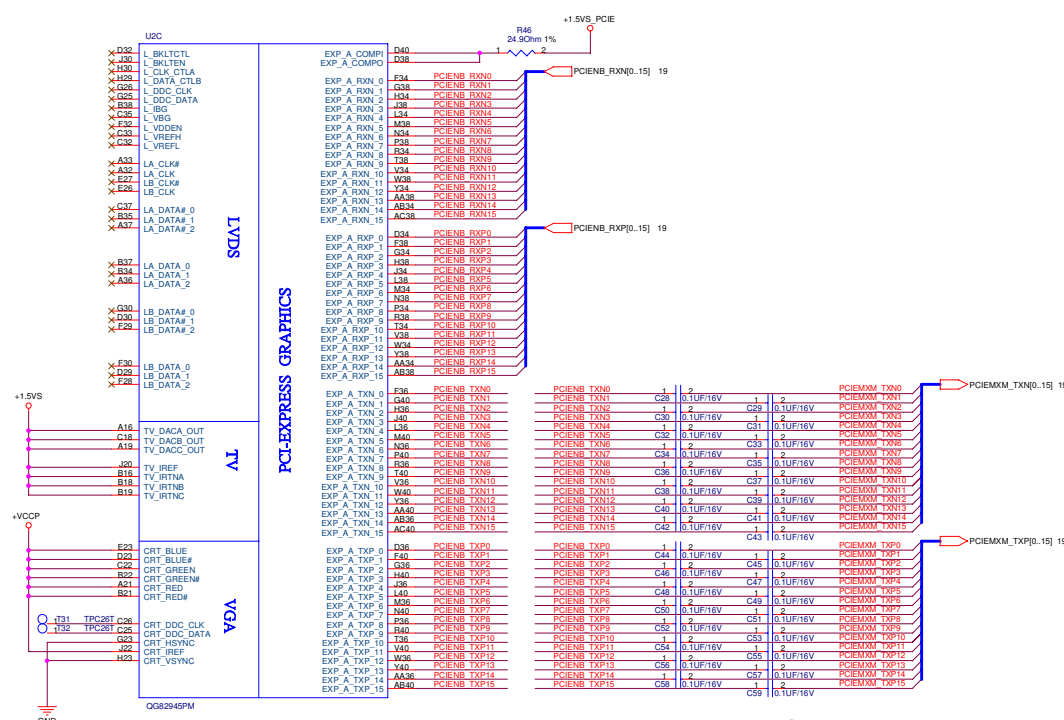

Place close to MXM Connector

ASUS
ASUSTek Computer INC. Title: NB_945PM_GRAPHIC
Engineer: Jack Hsu
Size Project Name Rev
Custom Z84J 1.1
Date: 11/11/2006 Sheet: 7 of 88

<< Kennedy_Zhang >>

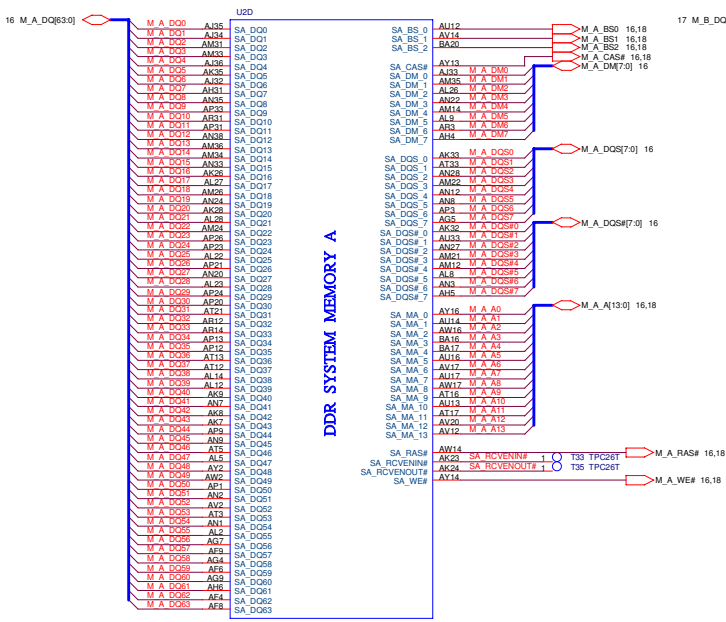

QG82945PM

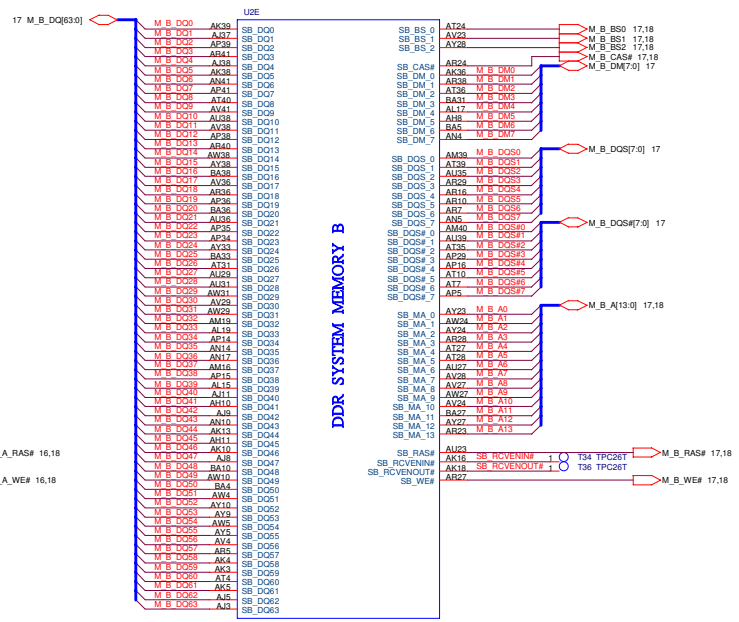

QG82945PM

ASUS
ASUSTek Computer INC. Engineer: Jack Hsu
Title: NB_945PM_DDR2
Size: Custom Project Name: Z84J Rev: 1.1
Date: 11/11/2006 Sheet: 6 of 66

<< Kennedy_Zhang >>

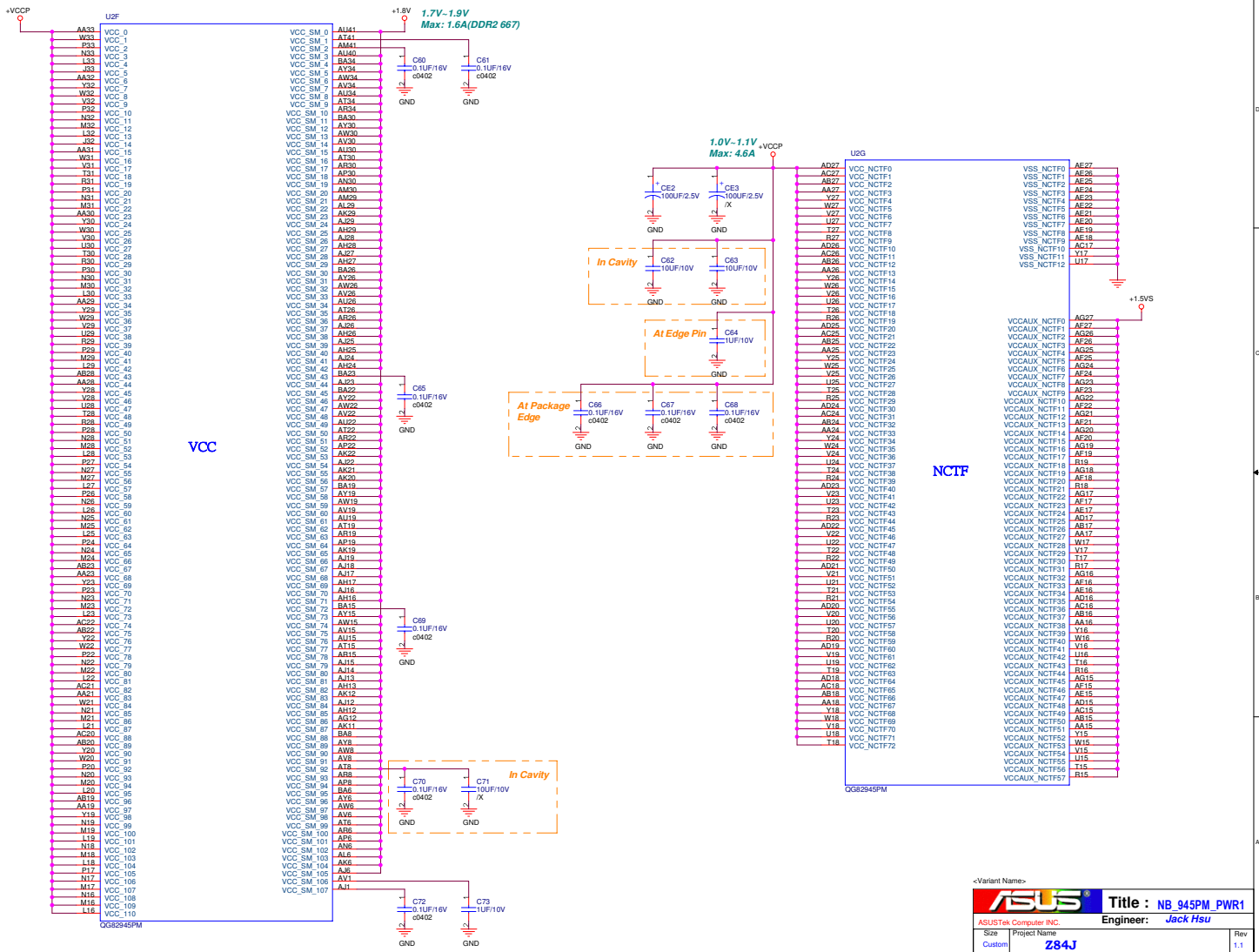

ASUS
ASUSTek Computer Inc. Title: NB_945PM_PWR1
Engineer: Jack Hsu

Size	Project Name	Rev
Custom	Z84J	1.1
Date: 01/10/2006	Sheet: 6 of 66	

« Kennedy_Zhang »

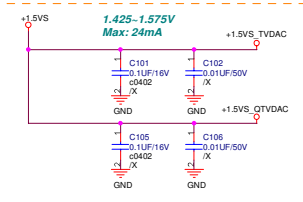
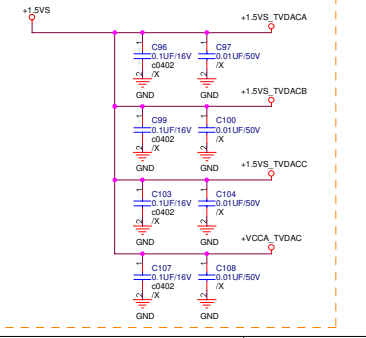
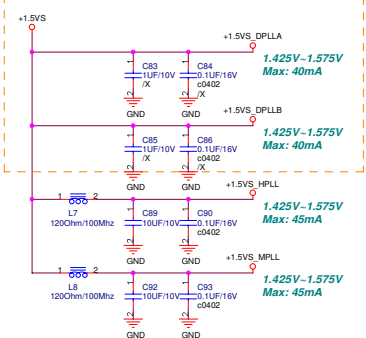
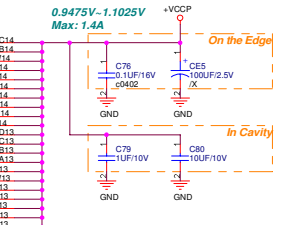
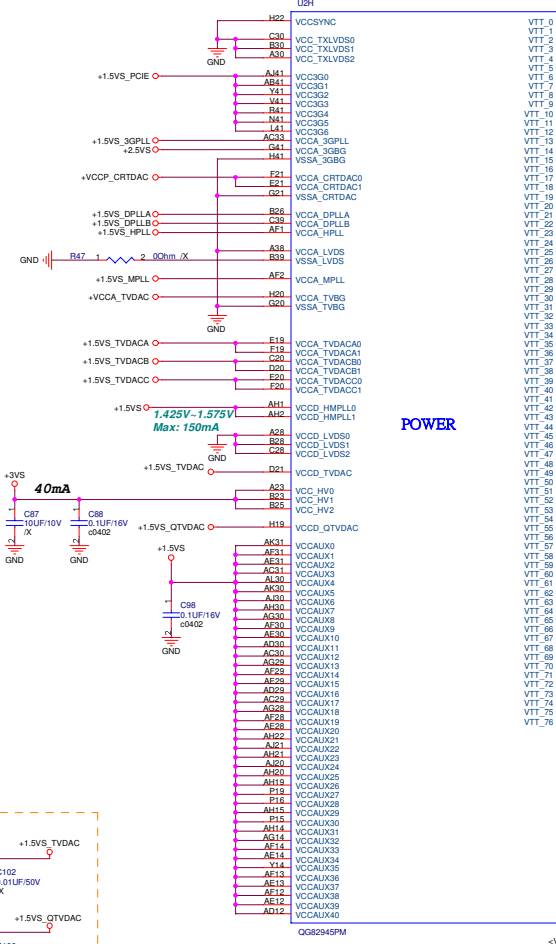
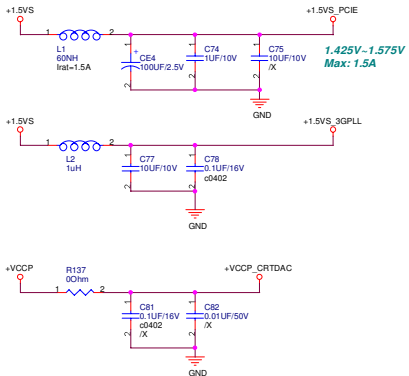

POWER

ASUS		Title: NB_945PM_PWR2	
ASUSTek Computer INC.	Project Name	Engineer: Jack Hsu	Rev
Size	Custom	Z84J	1.1
Date: 2008.11.31	Sheet: 10	of	88

<< Kennedy_Zhang >>

U21	VSS	AK34
AC41	VSS_0	VSS_97
AA41	VSS_1	VSS_98
WA1	VSS_2	VSS_99
TA1	VSS_3	VSS_100
PA1	VSS_4	VSS_101
MA1	VSS_5	VSS_102
JA1	VSS_6	VSS_103
IA1	VSS_7	VSS_104
AV40	VSS_8	VSS_105
AP40	VSS_9	VSS_106
AN40	VSS_10	VSS_107
AK40	VSS_11	VSS_108
AL40	VSS_12	VSS_109
AH40	VSS_13	VSS_110
AG40	VSS_14	VSS_111
AF40	VSS_15	VSS_112
AE40	VSS_16	VSS_113
AD40	VSS_17	VSS_114
AV39	VSS_18	VSS_115
AW39	VSS_19	VSS_116
AX39	VSS_20	VSS_117
AN39	VSS_21	VSS_118
AM39	VSS_22	VSS_119
AL39	VSS_23	VSS_120
AK39	VSS_24	VSS_121
AJ39	VSS_25	VSS_122
AI39	VSS_26	VSS_123
Y39	VSS_27	VSS_124
W39	VSS_28	VSS_125
V39	VSS_29	VSS_126
T39	VSS_30	VSS_127
P39	VSS_31	VSS_128
M39	VSS_32	VSS_129
L39	VSS_33	VSS_130
K39	VSS_34	VSS_131
J39	VSS_35	VSS_132
I39	VSS_36	VSS_133
H39	VSS_37	VSS_134
G39	VSS_38	VSS_135
F39	VSS_39	VSS_136
E39	VSS_40	VSS_137
AT38	VSS_41	VSS_138
AM38	VSS_42	VSS_139
AH38	VSS_43	VSS_140
AG38	VSS_44	VSS_141
AF38	VSS_45	VSS_142
AE38	VSS_46	VSS_143
AD38	VSS_47	VSS_144
AK37	VSS_48	VSS_145
AH37	VSS_49	VSS_146
AG37	VSS_50	VSS_147
AF37	VSS_51	VSS_148
AE37	VSS_52	VSS_149
AD37	VSS_53	VSS_150
Y37	VSS_54	VSS_151
W37	VSS_55	VSS_152
V37	VSS_56	VSS_153
T37	VSS_57	VSS_154
P37	VSS_58	VSS_155
M37	VSS_59	VSS_156
L37	VSS_60	VSS_157
K37	VSS_61	VSS_158
J37	VSS_62	VSS_159
I37	VSS_63	VSS_160
H37	VSS_64	VSS_161
G37	VSS_65	VSS_162
F37	VSS_66	VSS_163
E37	VSS_67	VSS_164
AV36	VSS_68	VSS_165
AW36	VSS_69	VSS_166
AX36	VSS_70	VSS_167
AN36	VSS_71	VSS_168
AM36	VSS_72	VSS_169
AL36	VSS_73	VSS_170
AK36	VSS_74	VSS_171
AJ36	VSS_75	VSS_172
AI36	VSS_76	VSS_173
Y36	VSS_77	VSS_174
W36	VSS_78	VSS_175
V36	VSS_79	VSS_176
T36	VSS_80	VSS_177
P36	VSS_81	VSS_178
M36	VSS_82	VSS_179
L36	VSS_83	
K36	VSS_84	
J36	VSS_85	
I36	VSS_86	
H36	VSS_87	
G36	VSS_88	
F36	VSS_89	
E36	VSS_90	
AV35	VSS_91	
AW35	VSS_92	
AX35	VSS_93	
AN35	VSS_94	
AM35	VSS_95	
AL35	VSS_96	
AK34	VSS_97	

GND
QG62949PM

VSS

GND

U21	VSS	J11
AT20	VSS_180	VSS_273
AN20	VSS_181	VSS_274
AM20	VSS_182	VSS_275
AL20	VSS_183	VSS_276
AK20	VSS_184	VSS_277
AJ20	VSS_185	VSS_278
AI20	VSS_186	VSS_279
Y20	VSS_187	VSS_280
W20	VSS_188	VSS_281
V20	VSS_189	VSS_282
T20	VSS_190	VSS_283
P20	VSS_191	VSS_284
M20	VSS_192	VSS_285
L20	VSS_193	VSS_286
K20	VSS_194	VSS_287
J20	VSS_195	VSS_288
I20	VSS_196	VSS_289
H20	VSS_197	VSS_290
G20	VSS_198	VSS_291
F20	VSS_199	VSS_292
E20	VSS_200	VSS_293
AV19	VSS_201	VSS_294
AW19	VSS_202	VSS_295
AX19	VSS_203	VSS_296
AN19	VSS_204	VSS_297
AM19	VSS_205	VSS_298
AL19	VSS_206	VSS_299
AK19	VSS_207	VSS_300
AJ19	VSS_208	VSS_301
AI19	VSS_209	VSS_302
Y19	VSS_210	VSS_303
W19	VSS_211	VSS_304
V19	VSS_212	VSS_305
T19	VSS_213	VSS_306
P19	VSS_214	VSS_307
M19	VSS_215	VSS_308
L19	VSS_216	VSS_309
K19	VSS_217	VSS_310
J19	VSS_218	VSS_311
I19	VSS_219	VSS_312
H19	VSS_220	VSS_313
G19	VSS_221	VSS_314
F19	VSS_222	VSS_315
E19	VSS_223	VSS_316
AV18	VSS_224	VSS_317
AW18	VSS_225	VSS_318
AX18	VSS_226	VSS_319
AN18	VSS_227	VSS_320
AM18	VSS_228	VSS_321
AL18	VSS_229	VSS_322
AK18	VSS_230	VSS_323
AJ18	VSS_231	VSS_324
AI18	VSS_232	VSS_325
Y18	VSS_233	VSS_326
W18	VSS_234	VSS_327
V18	VSS_235	VSS_328
T18	VSS_236	VSS_329
P18	VSS_237	VSS_330
M18	VSS_238	VSS_331
L18	VSS_239	VSS_332
K18	VSS_240	VSS_333
J18	VSS_241	VSS_334
I18	VSS_242	VSS_335
H18	VSS_243	VSS_336
G18	VSS_244	VSS_337
F18	VSS_245	VSS_338
E18	VSS_246	VSS_339
AV17	VSS_247	VSS_340
AW17	VSS_248	VSS_341
AX17	VSS_249	VSS_342
AN17	VSS_250	VSS_343
AM17	VSS_251	VSS_344
AL17	VSS_252	VSS_345
AK17	VSS_253	VSS_346
AJ17	VSS_254	VSS_347
AI17	VSS_255	VSS_348
Y17	VSS_256	VSS_349
W17	VSS_257	VSS_350
V17	VSS_258	VSS_351
T17	VSS_259	VSS_352
P17	VSS_260	VSS_353
M17	VSS_261	VSS_354
L17	VSS_262	VSS_355
K17	VSS_263	VSS_356
J17	VSS_264	VSS_357
I17	VSS_265	VSS_358
H17	VSS_266	VSS_359
G17	VSS_267	VSS_360
F17	VSS_268	
E17	VSS_269	
AD11	VSS_270	
AA11	VSS_271	
Y11	VSS_272	

GND
QG62949PM

VSS

GND

ASUS
ASUSTek Computer INC. Engineer: Jack Hsu
Title: NB_945PM_GND
Size: Custom Project Name: Z84J Rev: 1.1
Date: 11/10/2006 Sheet: 11 of 68

<< Kennedy_Zhang >>

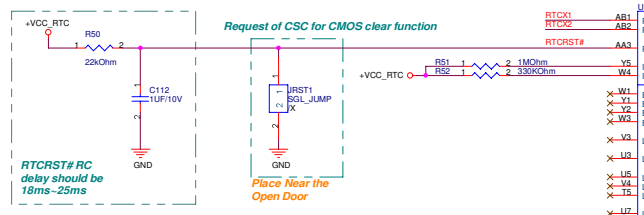
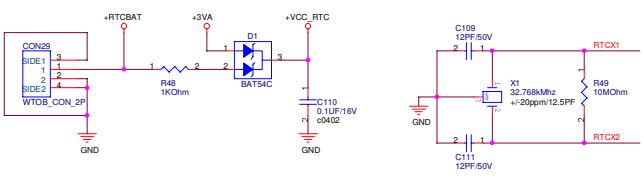

ACZ_SDIN0	CODEC
ACZ_SDIN1	MODEM

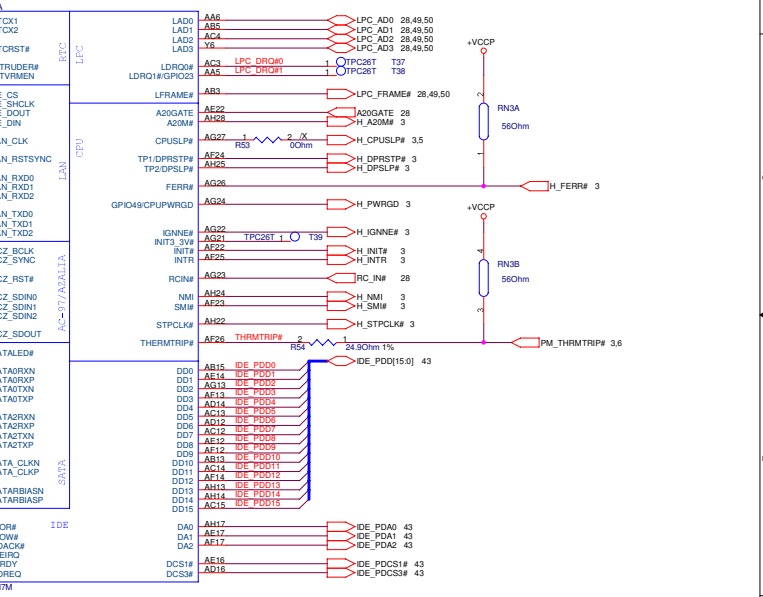
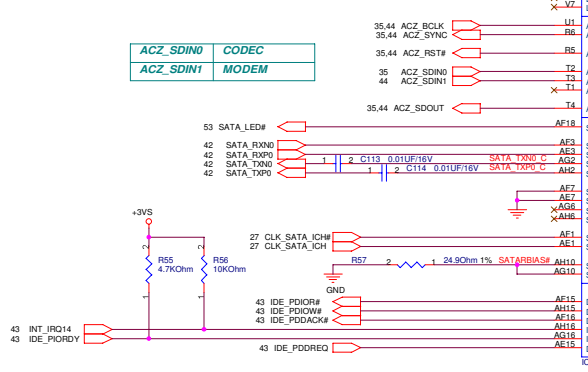

ASUS
ASUSTek Computer INC. Title: SB ICH7M_1
Engineer: Jack Hsu

Size	Project Name	Rev
Custom	Z84J	1.1
Date: 2006.11.01	Sheet: 12	of 68

<< Kennedy_Zhang >>

PCI Device	REQ?#	GNT?#	INT?#	IDSEL
RSC632	PCI_REQ#0	PCI_GNT#0	INTA, B	AD17

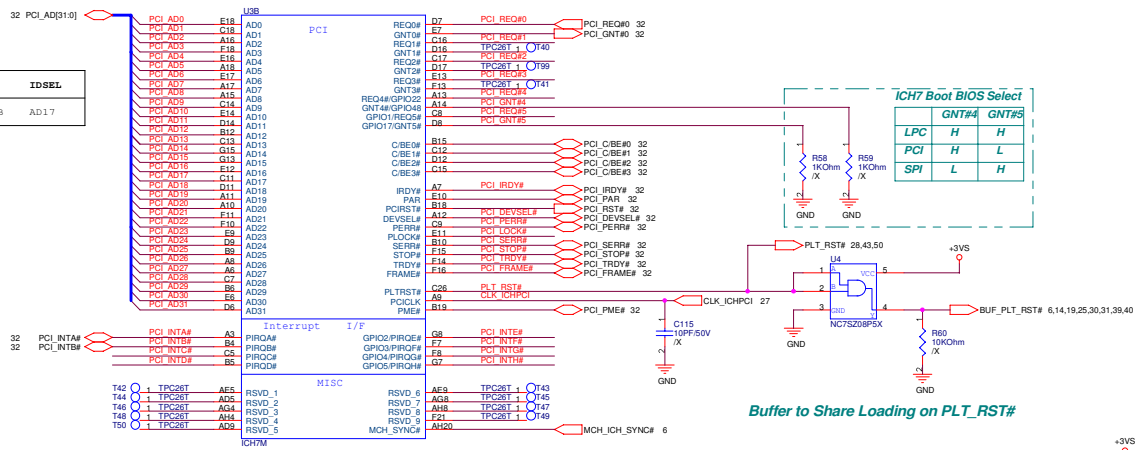

Buffer to Share Loading on PLT_RST#

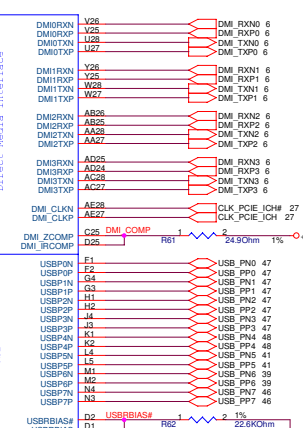
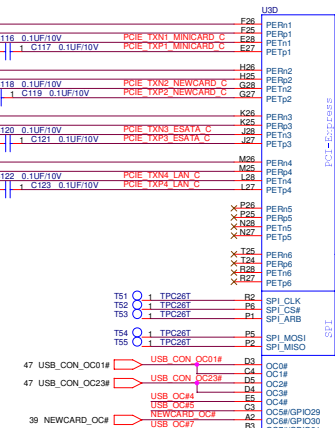
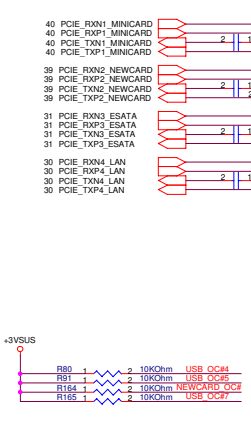

- USB 0 USB Conn.
- USB 1 USB Conn.
- USB 2 USB Conn.
- USB 3 USB Conn.
- USB 4 Bluetooth
- USB 5 TV-Tuner
- USB 6 New Card
- USB 7 Camera

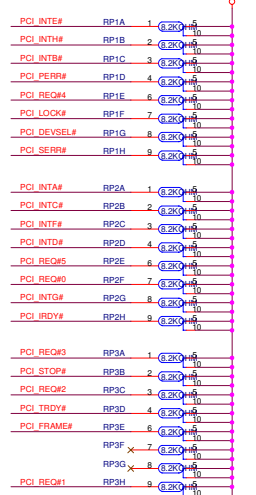

ASUS Title: SB ICH7M 2
 ASUSTek Computer, INC. Engineer: Jack Hsu
 Custom Project Name: Z84J
 Date: 11/11/2006 Sheet: 13 of 88

<< Kennedy_Zhang >>

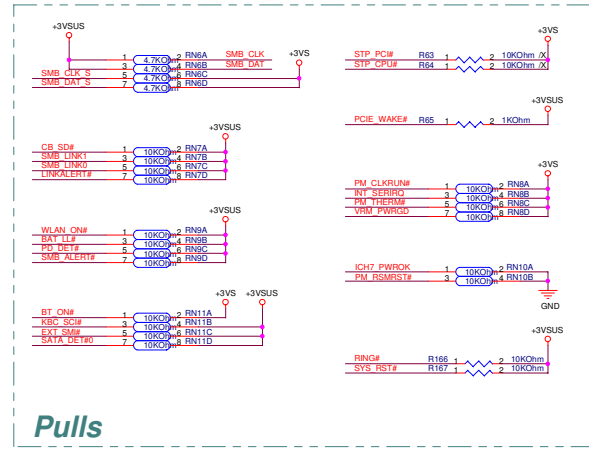
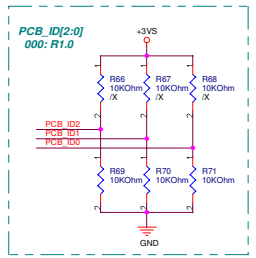
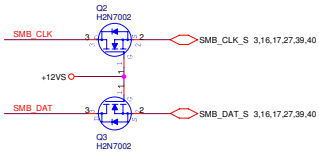
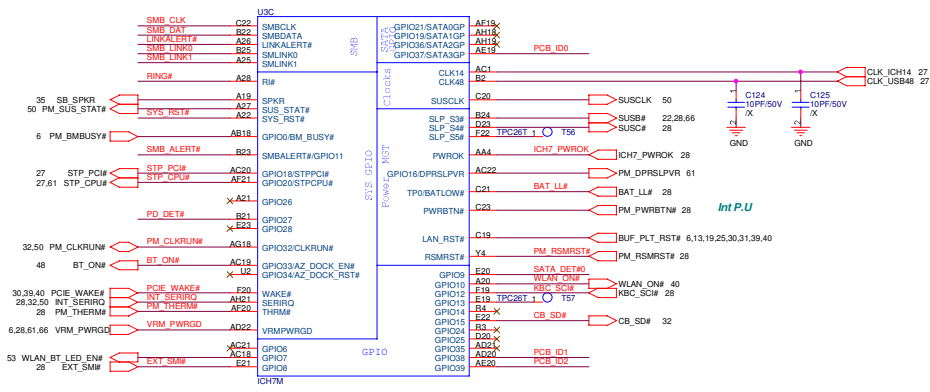

ASUS
ASUSTek Computer, Inc. Title: SB ICH7M 3
Engineer: Jack Hsu

Size	Project Name	Rev
Custom	Z84J	1.1
Date: 11/11/2006	Sheet: 14	of 68

<< Kennedy_Zhang >>

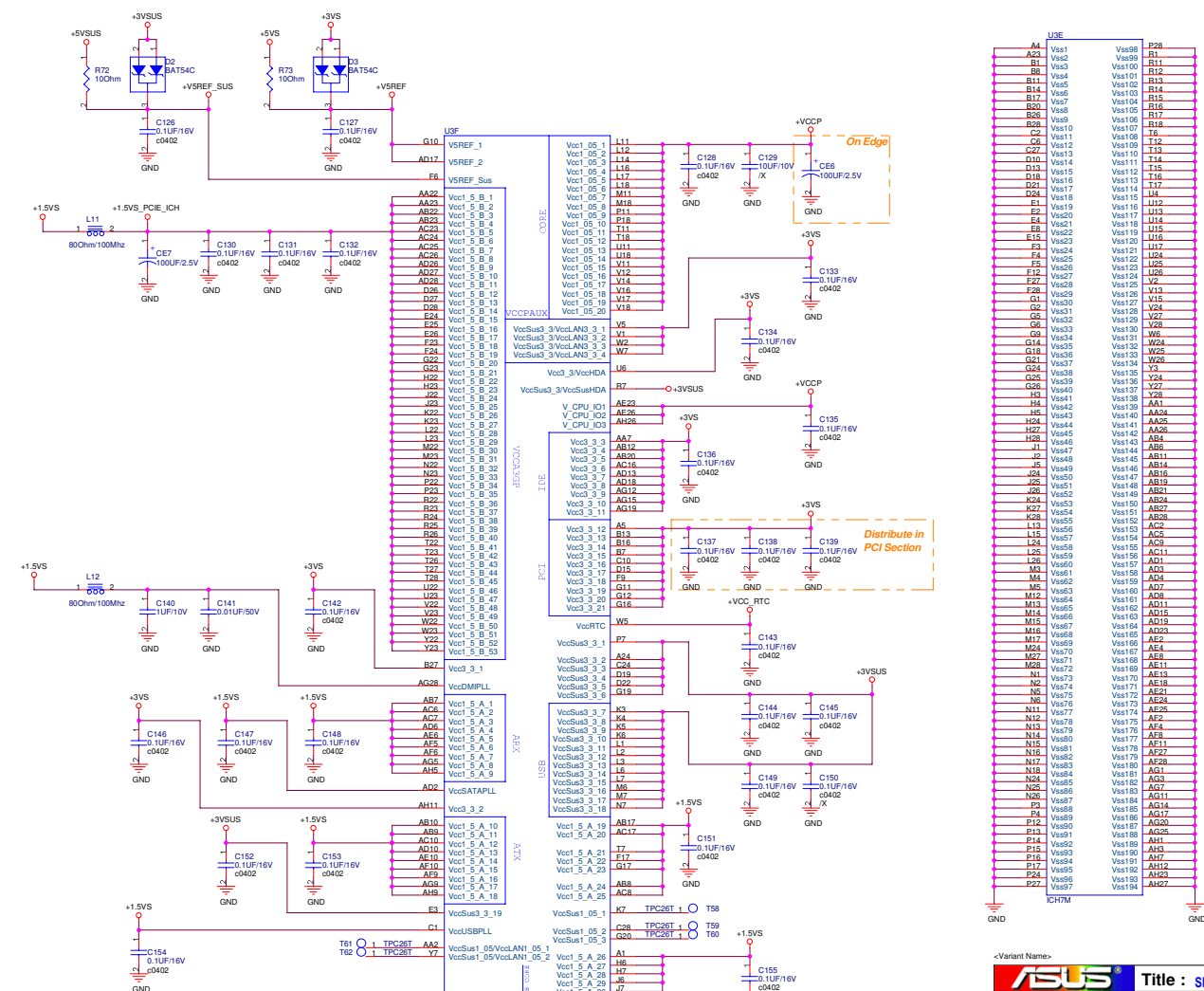

Pin	Power Plane	Pin	Power Plane
M4	Vcc1_5_B_1	P28	Vcc1_5_B_1
A23	Vcc1_5_B_2	R1	Vcc1_5_B_1
B1	Vcc1_5_B_3	R10	Vcc1_5_B_1
B6	Vcc1_5_B_4	R12	Vcc1_5_B_1
B11	Vcc1_5_B_5	R13	Vcc1_5_B_1
B14	Vcc1_5_B_6	R15	Vcc1_5_B_1
B17	Vcc1_5_B_7	R16	Vcc1_5_B_1
B20	Vcc1_5_B_8	R17	Vcc1_5_B_1
B25	Vcc1_5_B_9	R18	Vcc1_5_B_1
B28	Vcc1_5_B_10	R19	Vcc1_5_B_1
B30	Vcc1_5_B_11	R20	Vcc1_5_B_1
B32	Vcc1_5_B_12	R21	Vcc1_5_B_1
B35	Vcc1_5_B_13	R22	Vcc1_5_B_1
B38	Vcc1_5_B_14	R23	Vcc1_5_B_1
B41	Vcc1_5_B_15	R24	Vcc1_5_B_1
B44	Vcc1_5_B_16	R25	Vcc1_5_B_1
B47	Vcc1_5_B_17	R26	Vcc1_5_B_1
B50	Vcc1_5_B_18	R27	Vcc1_5_B_1
B53	Vcc1_5_B_19	R28	Vcc1_5_B_1
B56	Vcc1_5_B_20	R29	Vcc1_5_B_1
B59	Vcc1_5_B_21	R30	Vcc1_5_B_1
B62	Vcc1_5_B_22	R31	Vcc1_5_B_1
B65	Vcc1_5_B_23	R32	Vcc1_5_B_1
B68	Vcc1_5_B_24	R33	Vcc1_5_B_1
B71	Vcc1_5_B_25	R34	Vcc1_5_B_1
B74	Vcc1_5_B_26	R35	Vcc1_5_B_1
B77	Vcc1_5_B_27	R36	Vcc1_5_B_1
B80	Vcc1_5_B_28	R37	Vcc1_5_B_1
B83	Vcc1_5_B_29	R38	Vcc1_5_B_1
B86	Vcc1_5_B_30	R39	Vcc1_5_B_1
B89	Vcc1_5_B_31	R40	Vcc1_5_B_1
B92	Vcc1_5_B_32	R41	Vcc1_5_B_1
B95	Vcc1_5_B_33	R42	Vcc1_5_B_1
B98	Vcc1_5_B_34	R43	Vcc1_5_B_1
B101	Vcc1_5_B_35	R44	Vcc1_5_B_1
B104	Vcc1_5_B_36	R45	Vcc1_5_B_1
B107	Vcc1_5_B_37	R46	Vcc1_5_B_1
B110	Vcc1_5_B_38	R47	Vcc1_5_B_1
B113	Vcc1_5_B_39	R48	Vcc1_5_B_1
B116	Vcc1_5_B_40	R49	Vcc1_5_B_1
B119	Vcc1_5_B_41	R50	Vcc1_5_B_1
B122	Vcc1_5_B_42	R51	Vcc1_5_B_1
B125	Vcc1_5_B_43	R52	Vcc1_5_B_1
B128	Vcc1_5_B_44	R53	Vcc1_5_B_1
B131	Vcc1_5_B_45	R54	Vcc1_5_B_1
B134	Vcc1_5_B_46	R55	Vcc1_5_B_1
B137	Vcc1_5_B_47	R56	Vcc1_5_B_1
B140	Vcc1_5_B_48	R57	Vcc1_5_B_1
B143	Vcc1_5_B_49	R58	Vcc1_5_B_1
B146	Vcc1_5_B_50	R59	Vcc1_5_B_1
B149	Vcc1_5_B_51	R60	Vcc1_5_B_1
B152	Vcc1_5_B_52	R61	Vcc1_5_B_1
B155	Vcc1_5_B_53	R62	Vcc1_5_B_1
B158	Vcc1_5_B_54	R63	Vcc1_5_B_1
B161	Vcc1_5_B_55	R64	Vcc1_5_B_1
B164	Vcc1_5_B_56	R65	Vcc1_5_B_1
B167	Vcc1_5_B_57	R66	Vcc1_5_B_1
B170	Vcc1_5_B_58	R67	Vcc1_5_B_1
B173	Vcc1_5_B_59	R68	Vcc1_5_B_1
B176	Vcc1_5_B_60	R69	Vcc1_5_B_1
B179	Vcc1_5_B_61	R70	Vcc1_5_B_1
B182	Vcc1_5_B_62	R71	Vcc1_5_B_1
B185	Vcc1_5_B_63	R72	Vcc1_5_B_1
B188	Vcc1_5_B_64	R73	Vcc1_5_B_1
B191	Vcc1_5_B_65	R74	Vcc1_5_B_1
B194	Vcc1_5_B_66	R75	Vcc1_5_B_1
B197	Vcc1_5_B_67	R76	Vcc1_5_B_1
B200	Vcc1_5_B_68	R77	Vcc1_5_B_1
B203	Vcc1_5_B_69	R78	Vcc1_5_B_1
B206	Vcc1_5_B_70	R79	Vcc1_5_B_1
B209	Vcc1_5_B_71	R80	Vcc1_5_B_1
B212	Vcc1_5_B_72	R81	Vcc1_5_B_1
B215	Vcc1_5_B_73	R82	Vcc1_5_B_1
B218	Vcc1_5_B_74	R83	Vcc1_5_B_1
B221	Vcc1_5_B_75	R84	Vcc1_5_B_1
B224	Vcc1_5_B_76	R85	Vcc1_5_B_1
B227	Vcc1_5_B_77	R86	Vcc1_5_B_1
B230	Vcc1_5_B_78	R87	Vcc1_5_B_1
B233	Vcc1_5_B_79	R88	Vcc1_5_B_1
B236	Vcc1_5_B_80	R89	Vcc1_5_B_1
B239	Vcc1_5_B_81	R90	Vcc1_5_B_1
B242	Vcc1_5_B_82	R91	Vcc1_5_B_1
B245	Vcc1_5_B_83	R92	Vcc1_5_B_1
B248	Vcc1_5_B_84	R93	Vcc1_5_B_1
B251	Vcc1_5_B_85	R94	Vcc1_5_B_1
B254	Vcc1_5_B_86	R95	Vcc1_5_B_1
B257	Vcc1_5_B_87	R96	Vcc1_5_B_1
B260	Vcc1_5_B_88	R97	Vcc1_5_B_1
B263	Vcc1_5_B_89	R98	Vcc1_5_B_1
B266	Vcc1_5_B_90	R99	Vcc1_5_B_1
B269	Vcc1_5_B_91	R100	Vcc1_5_B_1

ASUS Logo
Title : SB ICH7M PWR
 Engineer: Jack Hsu
 Size: Custom
 Project Name: Z84J
 Date: 11/10/2006
 Sheet: 15 of 88
 Rev: 1.1

<< Kennedy_Zhang >>

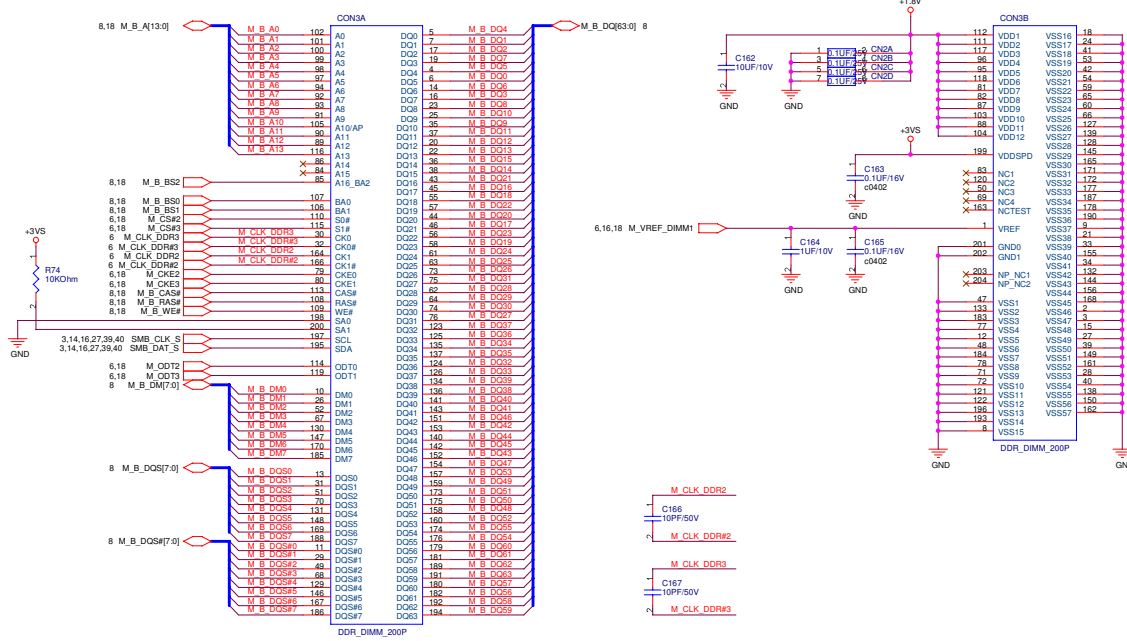

Standard Type SODIMM Connector H=5.2mm

<Variant Name>

ASUS		Title : DDR2 SO-DIMM1	
ASUSTek Computer INC.		Engineer: Jack Hsu	
Size	Project Name	Rev	
Custom	Z84J	1.1	
Date: 01/11/2006	Sheet: 17	of 68	

<< Kennedy_Zhang >>

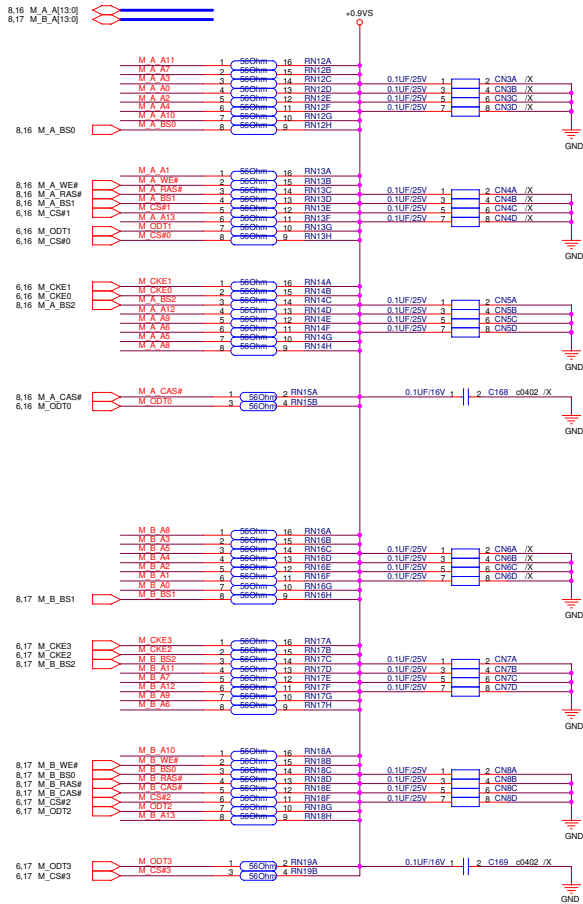
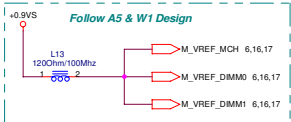

<Variant Names>

ASUS		Title : DDR2 Termination	
ASUSTek Computer INC.		Engineer: Jack Hsu	
Size	Project Name	Rev	
Custom	Z84J	1.1	
Date: 11/11/2006	Sheet: 18	of	88

<< Kennedy_Zhang >>

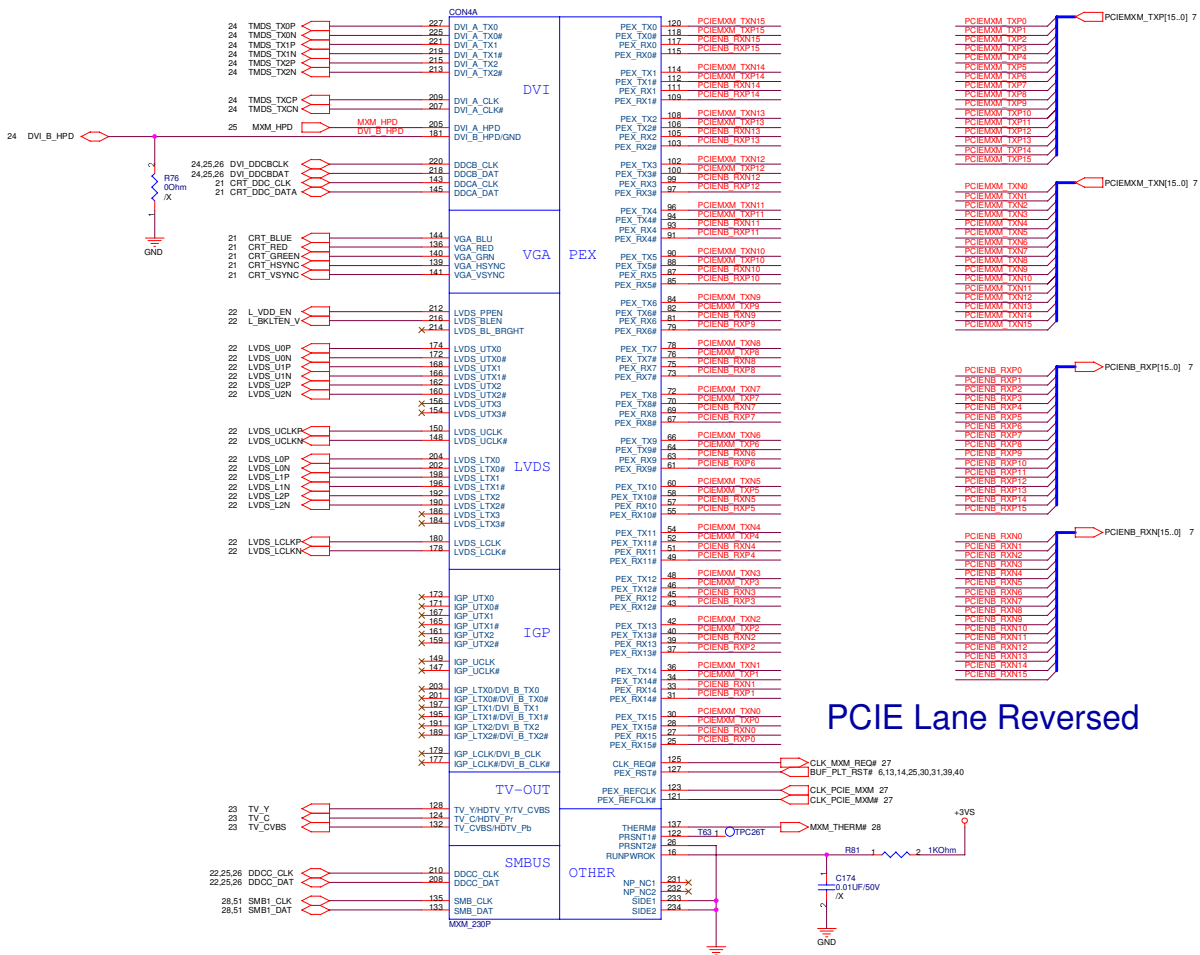

DDCA_CLK, DDCA_DAT,
DDCB_CLK, DDCB_DAT,
DDCC_CLK, DDCC_DAT,
Should have 2.2K PULL-UP to +3.3V on MXM Module

THERM# -- Open Collector Output, Active Low, 5V tolerant
CLK_REQ# -- Output, Open Drain, Active Low

PCIE Lane Reversed

ASUS		Title : MXM Interface	
ASUSTek Computer INC.		Engineer: Jack Hsu	
Size	Project Name	Rev	
Custom	Z84J	1.1	
Date: 11/11/2008	Sheet	18	of 88

« Kennedy_Zhang »

MXM Connector Pin Definition

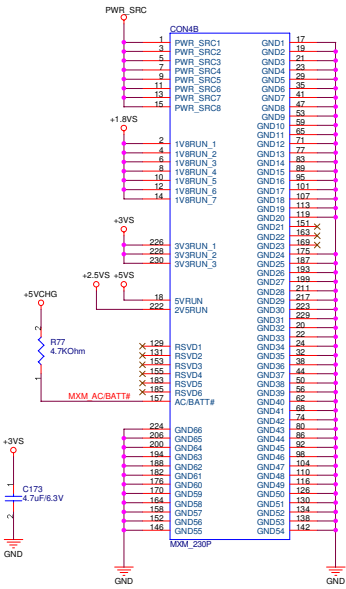

AC/BATT# : Input, 10K PULL-DOWN on Module.
 0= nominal performance
 1=high performance

Pin #	Signal Name	Pin #	Signal Name	Pin #	Signal Name	Pin #	Signal Name	Pin #	Signal Name	Pin #	Signal Name
1	PWR_SRC	2	1V8RUN	111	PEX_RX1	112	PEX_TX1#	222	2V5RUN		
3	PWR_SRC	4	1V8RUN	113	GND	114	PEX_TX1	223	GND	224	GND
5	PWR_SRC	6	1V8RUN	115	PEX_RX0#	116	GND	225	DVI_A_TX0#	226	3V3RUN
7	PWR_SRC	8	1V8RUN	117	PEX_RX0	118	PEX_TX0#	227	DVI_A_TX0	228	3V3RUN
9	PWR_SRC	10	1V8RUN	119	GND	120	PEX_TX0	229	GND	230	3V3RUN
11	PWR_SRC	12	1V8RUN	121	PEX_REFCLK#	122	PRSNT1#				
13	PWR_SRC	14	1V8RUN	123	PEX_REFCLK	124	TV_CHDVTV_Pr				
15	PWR_SRC	16	RUNPWROK	125	CLK_REC#	126	GND				
17	GND	18	5VRUN	127	PEX_RST#	128	TV_YHDTV_Y/TV_CVBS				
19	GND	20	GND	129	RSVD	130	GND				
21	GND	22	GND	131	RSVD	132	TV_CVBS/HDTV_Pb				
23	GND	24	GND	133	SMB_DAT	134	GND				
25	PEX_RX15#	26	PRSNT2#	135	SMB_CLK	136	VGA_RED				
27	PEX_RX15	28	PEX_TX15#	137	THERM#	138	GND				
29	GND	30	PEX_TX15	139	VGA_HSYNC	140	VGA_GRN				
31	PEX_RX14#	32	GND	141	VGA_VSYNC	142	GND				
33	PEX_RX14	34	PEX_TX14#	143	DDCA_CLK	144	VGA_BLU				
35	GND	36	PEX_TX14	145	DDCA_DAT	146	GND				
37	PEX_RX13#	38	GND	147	IGP	148	LVDS_UCLK#				
39	PEX_RX13	40	PEX_TX13#	149	IGP	150	LVDS_UCLK				
41	GND	42	PEX_TX13	151	IGP	152	GND				
43	PEX_RX12#	44	GND	153	RSVD	154	LVDS_UTX3#				
45	PEX_RX12	46	PEX_TX12#	155	RSVD	156	LVDS_UTX3				
47	GND	48	PEX_TX12	157	ACBATT#	158	GND				
49	PEX_RX11#	50	GND	159	IGP	160	LVDS_UTX2#				
51	PEX_RX11	52	PEX_TX11#	161	IGP	162	LVDS_UTX2				
53	GND	54	PEX_TX11	163	IGP	164	GND				
55	PEX_RX10#	56	GND	165	IGP	166	LVDS_UTX1#				
57	PEX_RX10	58	PEX_TX10#	167	IGP	168	LVDS_UTX1				
59	GND	60	PEX_TX10	169	IGP	170	GND				
61	PEX_RX9#	62	GND	171	IGP	172	LVDS_UTX0#				
63	PEX_RX9	64	PEX_TX9#	173	IGP	174	LVDS_UTX0				
65	GND	66	PEX_TX9	175	GND	176	GND				
67	PEX_RX8#	68	GND	177	IGP/DVI_B_CLK#	178	LVDS_LCLK#				
69	PEX_RX8	70	PEX_TX8#	179	IGP/DVI_B_CLK	180	LVDS_LCLK				
71	GND	72	PEX_TX8	181	DVI_B_HPD/GND	182	GND				
73	PEX_RX7#	74	GND	183	RSVD	184	LVDS_LTX3#				
75	PEX_RX7	76	PEX_TX7#	185	RSVD	186	LVDS_LTX3				
77	GND	78	PEX_TX7	187	GND	188	GND				
79	PEX_RX6#	80	GND	189	IGP/DVI_B_TX2#	190	LVDS_LTX2#				
81	PEX_RX6	82	PEX_TX6#	191	IGP/DVI_B_TX2	192	LVDS_LTX2				
83	GND	84	PEX_TX6	193	GND	194	GND				
85	PEX_RX5#	86	GND	195	IGP/DVI_B_TX1#	196	LVDS_LTX1#				
87	PEX_RX5	88	PEX_TX5#	197	IGP/DVI_B_TX1	198	LVDS_LTX1				
89	GND	90	PEX_TX5	199	GND	200	GND				
91	PEX_RX4#	92	GND	201	IGP/DVI_B_TX0#	202	LVDS_LTX0#				
93	PEX_RX4	94	PEX_TX4#	203	IGP/DVI_B_TX0	204	LVDS_LTX0				
95	GND	96	PEX_TX4	205	DVI_A_HPD	206	GND				
97	PEX_RX3#	98	GND	207	DVI_A_CLK#	208	DDCC_DAT				
99	PEX_RX3	100	PEX_TX3#	209	DVI_A_CLK	210	DDCC_CLK				
101	GND	102	PEX_TX3	211	GND	212	LVDS_PPEN				
103	PEX_RX2#	104	GND	213	DVI_A_TX2#	214	LVDS_BL_BRGHT				
105	PEX_RX2	106	PEX_TX2#	215	DVI_A_TX2	216	LVDS_BLEN				
107	GND	108	PEX_TX2	217	GND	218	DDCB_DAT				
109	PEX_RX1#	110	GND	219	DVI_A_TX1#	220	DDCB_CLK				

ASUS Logo
Title : MXM PWR & GND
 Project Name: **Z84J**
 Engineer: **Jack Hsu**
 Rev: **1.1**
 Date: **11/16/2009** Sheet **20** of **89**

« Kennedy_Zhang »

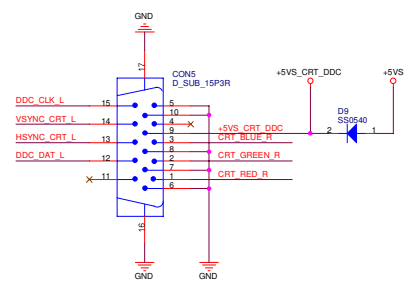
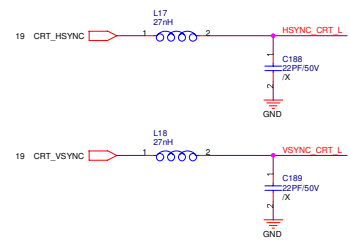
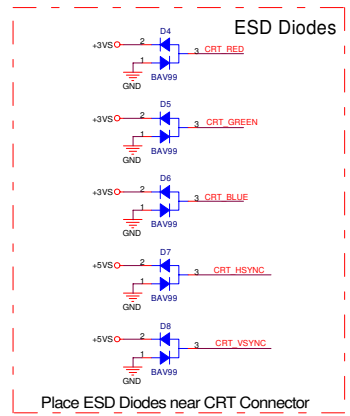
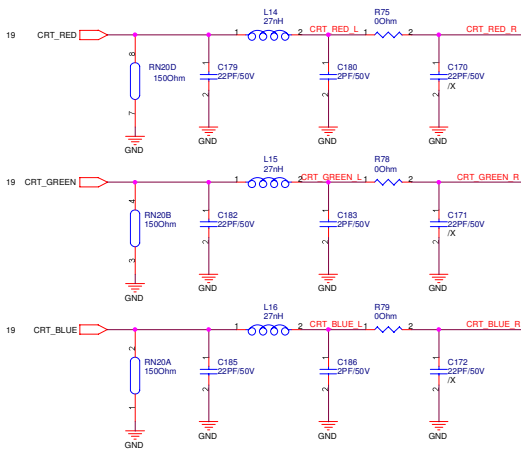

CRT Connector

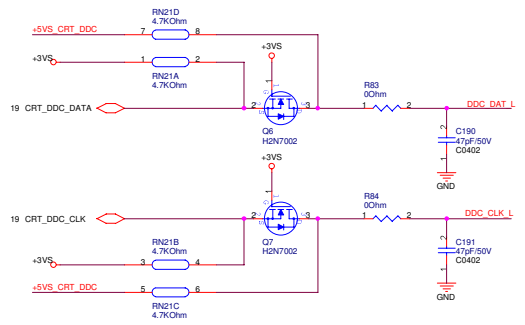

ASUS		Title : CRT Connector	
ASUSTek Computer INC.		Engineer: Jack Hsu	
Size	Project Name	Rev	
Custom	Z84J	1.1	
Date: 11/11/2005	Sheet 21	of	88

<< Kennedy_Zhang >>

LCD Power

3-3.6V SO-SIM:410 mA(500 mA Max.)

Cable Requirement:
Impedance: 100 ohm +/- 10%
Length Mismatch <= 10 mils
Twisted Pair(Not Ribbon)
Maximum Length <= 16"

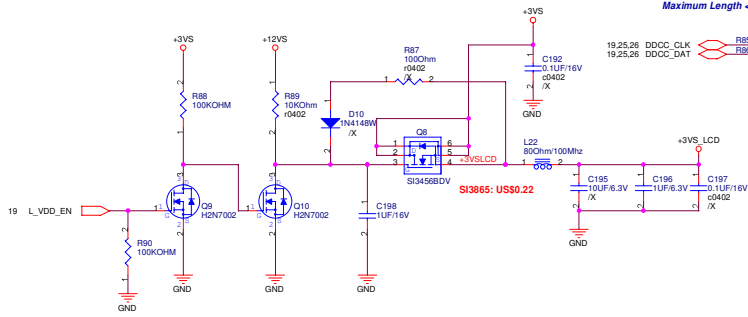

LCD LVDS Connector

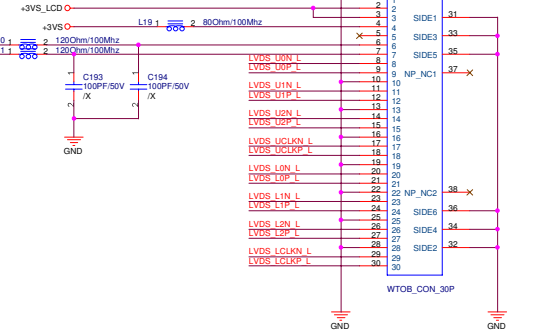

LCD Backlight Control INVERTER Connector

BIOS
LCD_BACKOFF#:
When user push "Fn+F7" button,
BIOS active this pin to turn off
back light.
PANEL ID1 = 1 : WSXGA+ 1690x1050
PANEL ID1 = 0 : WXGA 1280x800

PANEL ID0 RESERVED FOR VENDOR

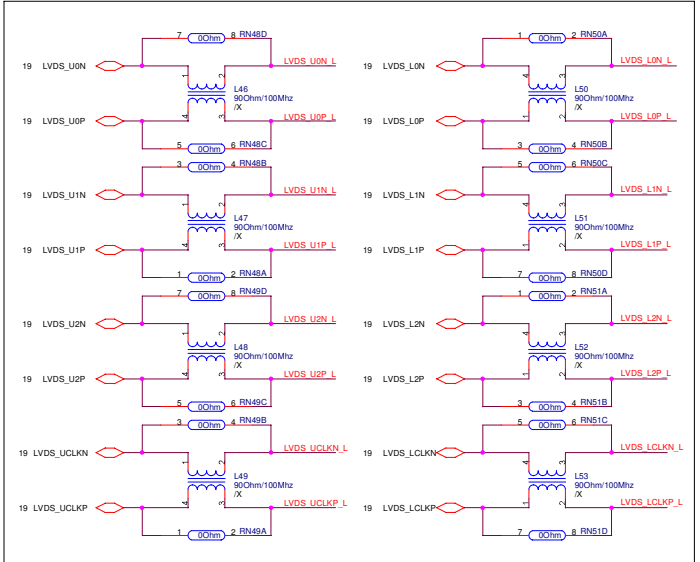
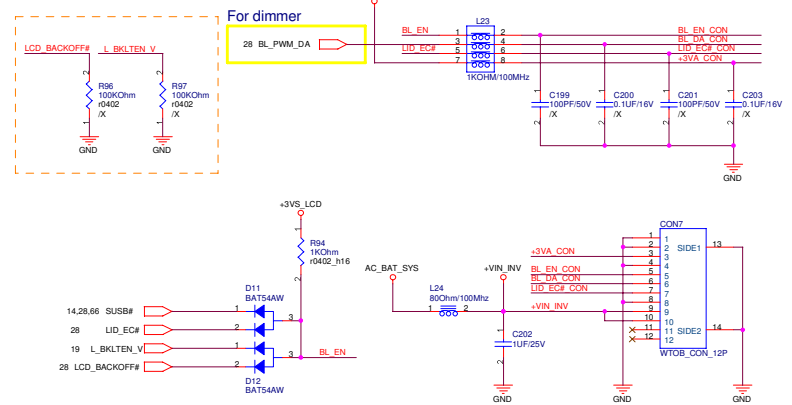

<Variant Name>
ASUS Title : LVDS & Inverter Conn.
ASUSTek Computer INC. Engineer: Jack Hsu
Size Project Name
Custom Z84J
Date: 11/11/2008 Sheet 22 of 28
Rev 1.1

<< Kennedy_Zhang >>

TV OUT Connector

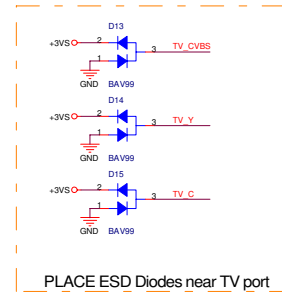
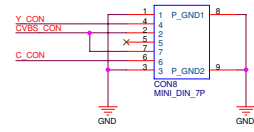
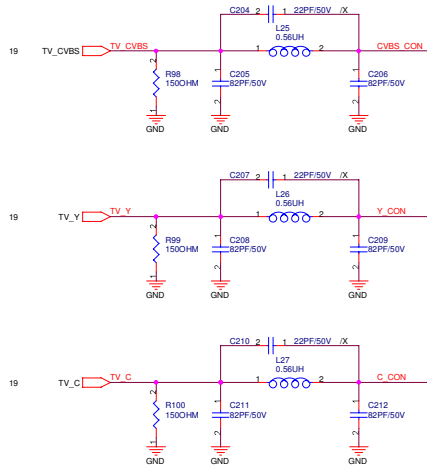

PLACE ESD Diodes near TV port

ASUS		Title : TV-OUT Connector	
ASUSTek Computer INC.		Engineer: Jack Hsu	
Size	Project Name		Rev
Custom	Z84J		1.1
Date: 11/11/2006		Sheet: 29	of 68

<< Kennedy_Zhang >>

HDMI Transmitter

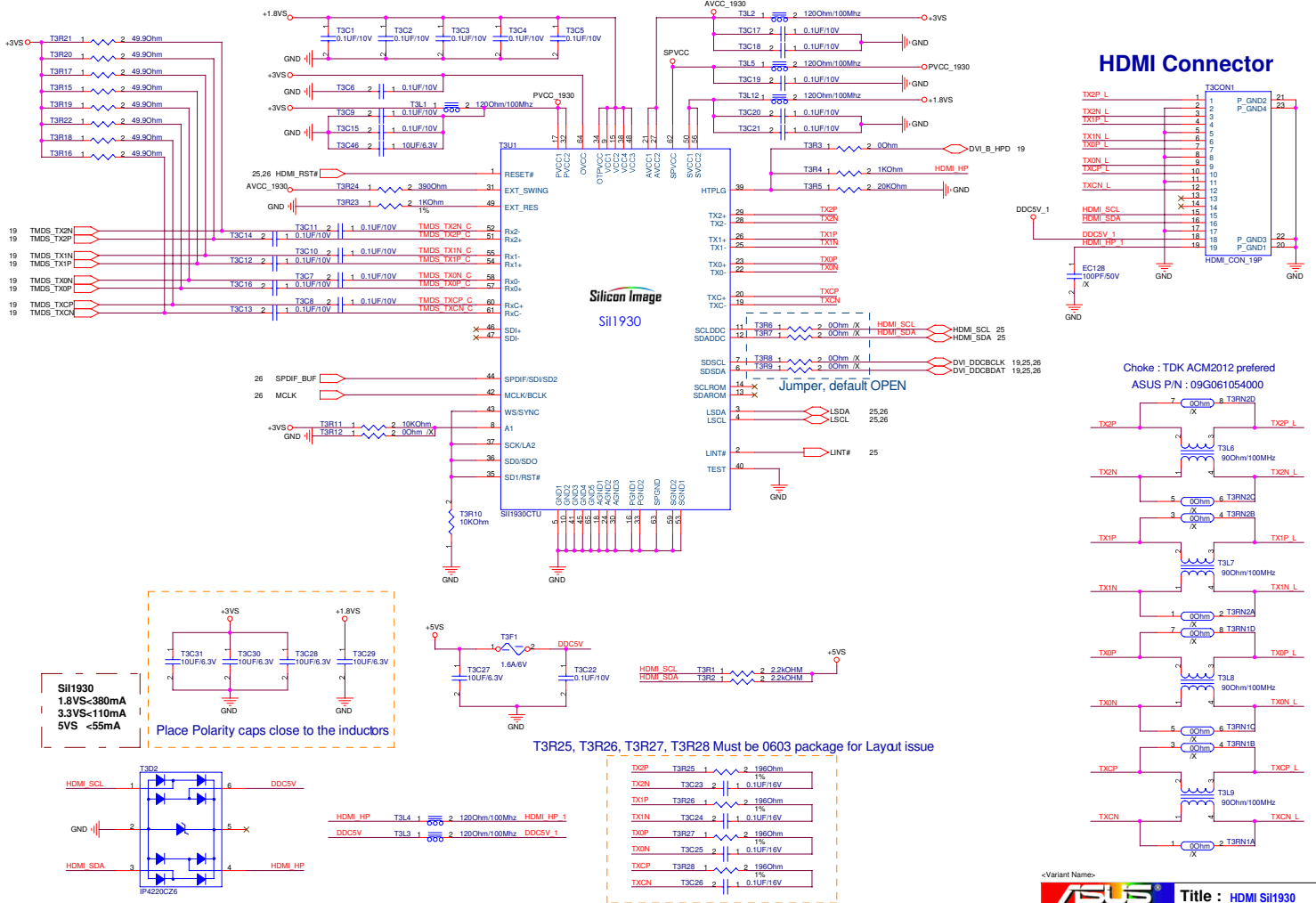

HDMI Connector

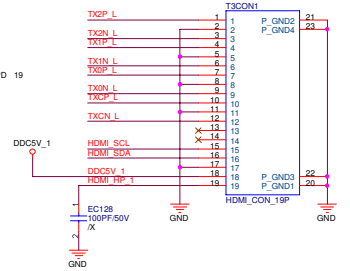

Choke : TDK ACM2012 preferred
ASUS P/N : 09G061054000

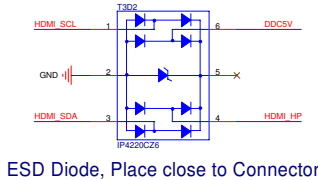
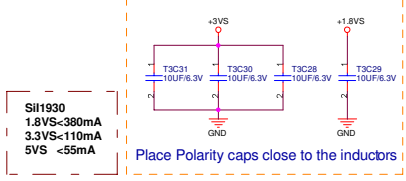
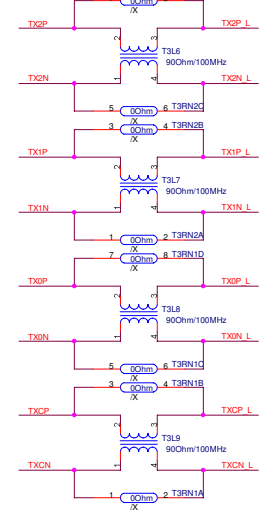

T3R25, T3R26, T3R27, T3R28 Must be 0603 package for Layout issue

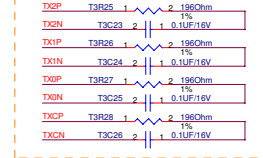

Source Termination, Place close to Transmitter
Refer to layout guide for detail placement

ASUS Title : HDMI SiI1930
Engineer: Jack Hsu
ASUSTek Computer INC.
Size: Project Name:
Custom: Z84J Rev: 1.1
Date: 11/31/2008 Sheet: 24 of 88

« Kennedy_Zhang »

D

D

C

C

B

B

A

A

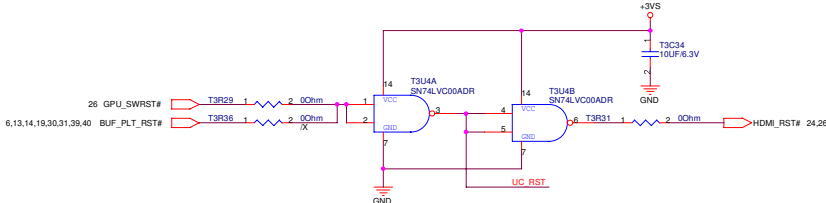

HDMI uController

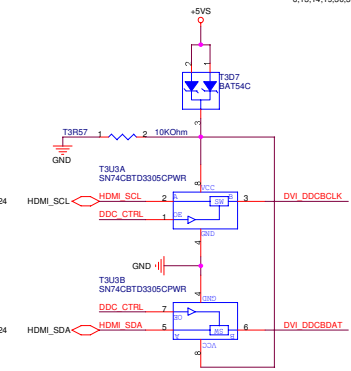

MUX

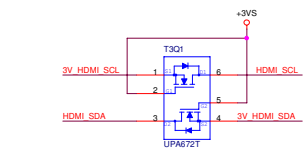
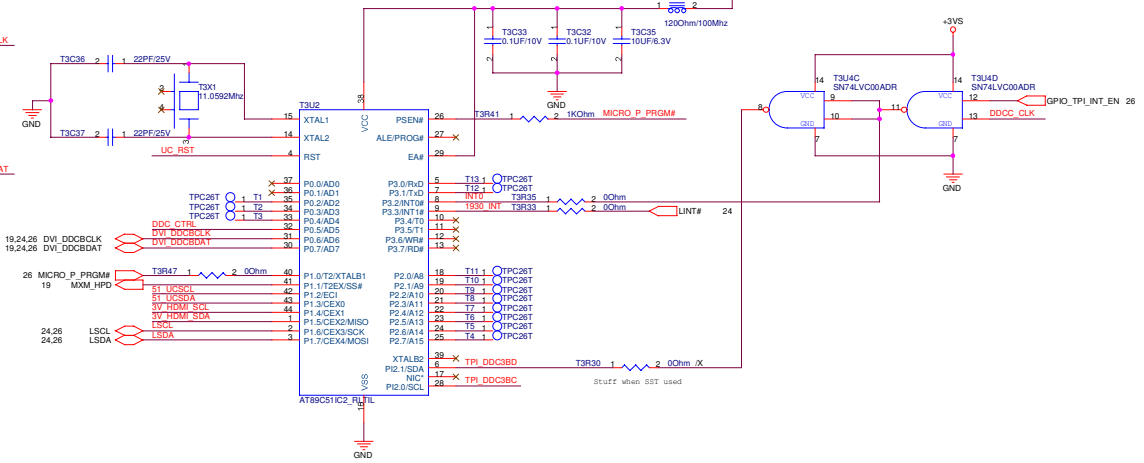

Level Shift

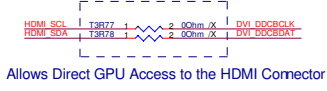

Allows Direct GPU Access to the HDMI Connector

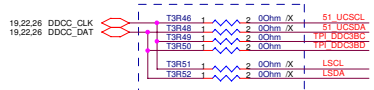

Jumper:
 Stuff T3R46, T3R48 Software I2C (SST)
 Stuff T3R49, T3R50 Hardware I2C (ATMEL)

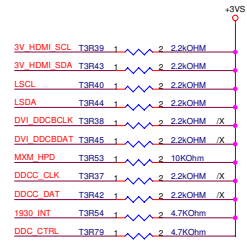

ASUS		Title : HDMI uController	
ASUSTek Computer INC.		Engineer: Jack Hsu	
Size	Project Name	Rev	1.1
Custom	Z84J	Date	11/13/2009
Sheet 26 of 88			

« Kennedy_Zhang »

I2C GPIO Controller

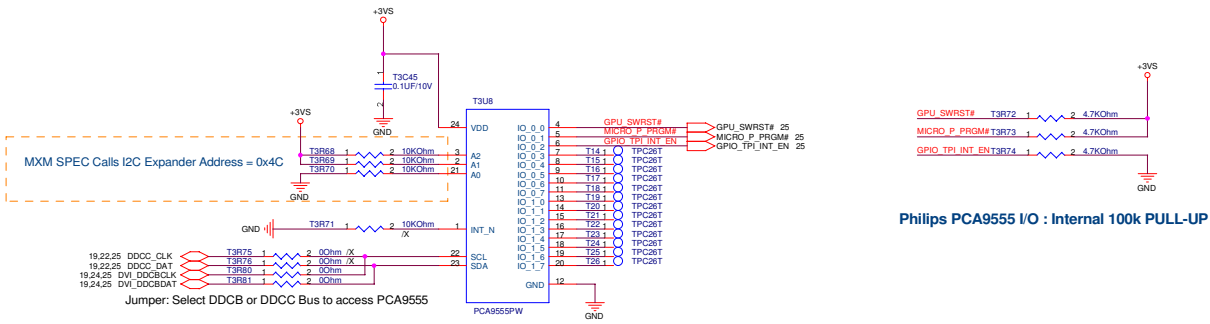

AK4113 Audio Codec

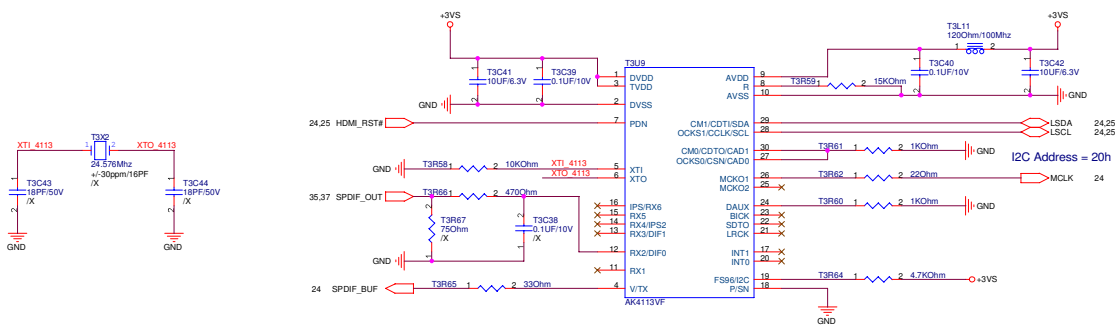

ASUS		Title : I2C EXP. & Codec
ASUSTek Computer INC.		Engineer: Jack Hsu
Size	Project Name	Rev
Custom	Z84J	1.1
Date: 11/11/2009	Sheet	26 of 69

« Kennedy_Zhang »

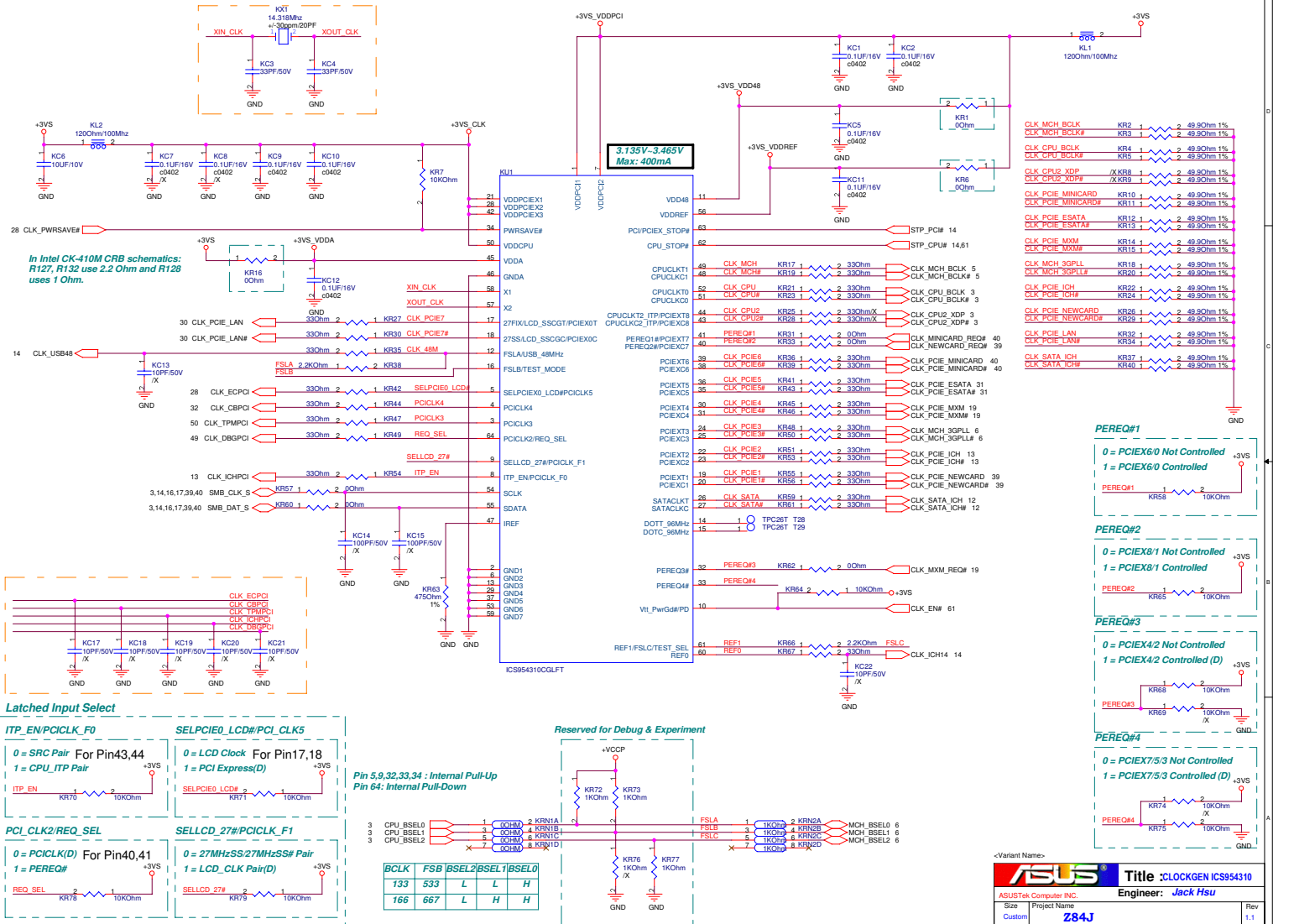

In Intel CK-410M CRB schematics: R127, R132 use 2.2 Ohm and R128 uses 1 Ohm.

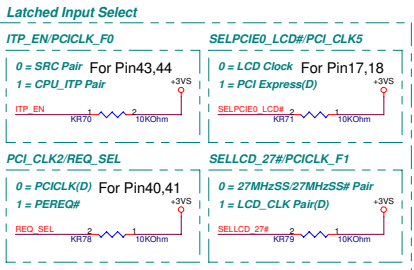

Pin 5,9,32,33,34 : Internal Pull-Up
 Pin 64: Internal Pull-Down

BCLK	FSB	BSEL2#	BSEL1	BSEL0
133	533	L	L	H
166	667	L	H	H

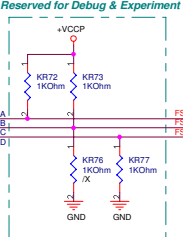

- CLK MCH BCLK KR2 2 49.90hm 1%
- CLK MCH BCLK# KR3 2 49.90hm 1%
- CLK CPU BCLK KR4 2 49.90hm 1%
- CLK CPU BCLK# KR5 2 49.90hm 1%
- CLK CPU2 XDP /XKR8 2 49.90hm 1%
- CLK CPU2 XDP# /XKR9 2 49.90hm 1%
- CLK PCIE MMINICARD KR10 1 2 49.90hm 1%
- CLK PCIE MMINICARD# KR11 1 2 49.90hm 1%
- CLK PCIE ESATA KR12 1 2 49.90hm 1%
- CLK PCIE ESATA# KR13 1 2 49.90hm 1%
- CLK PCIE MXXM KR14 1 2 49.90hm 1%
- CLK PCIE MXXM# KR15 1 2 49.90hm 1%
- CLK MCH 3GPLL KR18 2 49.90hm 1%
- CLK MCH 3GPLL# KR19 2 49.90hm 1%
- CLK PCIE ICH KR22 1 2 49.90hm 1%
- CLK PCIE ICH# KR24 1 2 49.90hm 1%
- CLK PCIE ESATA KR26 1 2 49.90hm 1%
- CLK PCIE NEWCARD KR29 1 2 49.90hm 1%
- CLK PCIE LAN KR32 1 2 49.90hm 1%
- CLK PCIE LAN# KR34 1 2 49.90hm 1%
- CLK SATA ICH KR37 1 2 49.90hm 1%
- CLK SATA ICH# KR40 1 2 49.90hm 1%

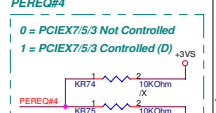
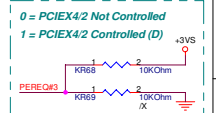
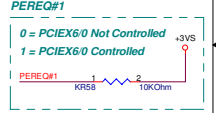

ASUSTek Computer, Inc. Title: CLOCKGEN ICS954310
 Engineer: Jack Hsu
 Size: Custom Project Name: Z84J
 Date: 11/11/2006 Rev: 1.1

<< Kennedy_Zhang >>

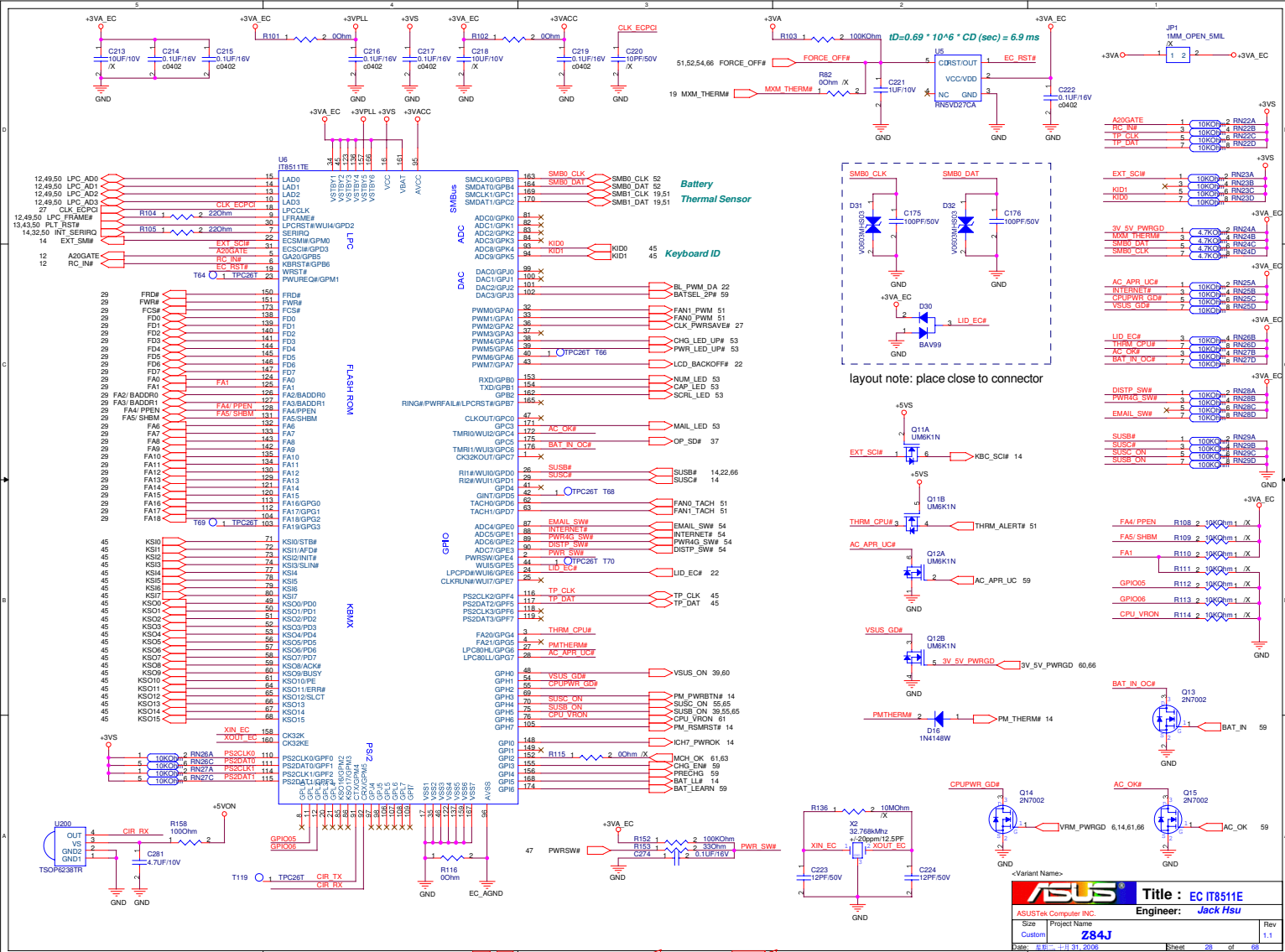

ASUS		Title : EC IT8511E	
ASUSTek Computer INC.		Engineer: Jack Hsu	
Size	Project Name	Rev	
Custom	Z84J	1.1	
Date: 11/11/2006	Sheet: 28	of 28	

« Kennedy_Zhang »

ISA ROM

EC Hardware Strapping

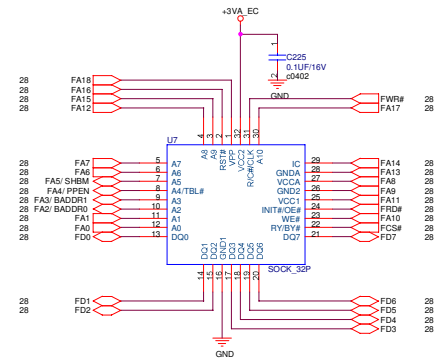
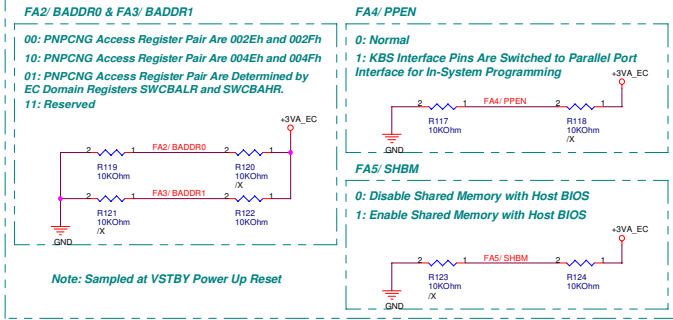

ASUS		Title :ISA ROM	
ASUSTek Computer INC.		Engineer: Jack Hsu	
Size	Project Name		Rev
Custom	Z84J		1.1
Date: 11/11/2006		Sheet: 29	of 68

<< Kennedy_Zhang >>

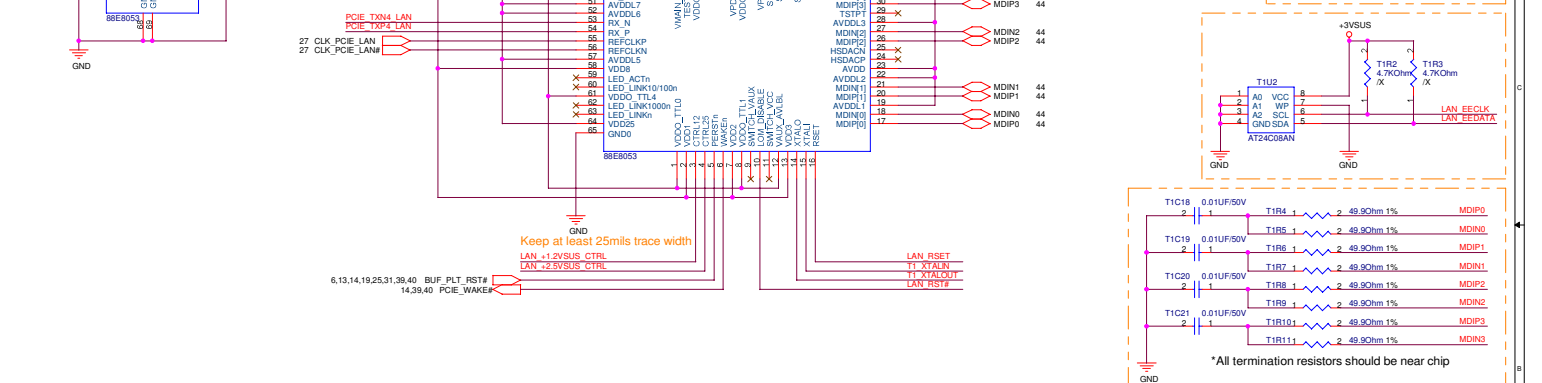
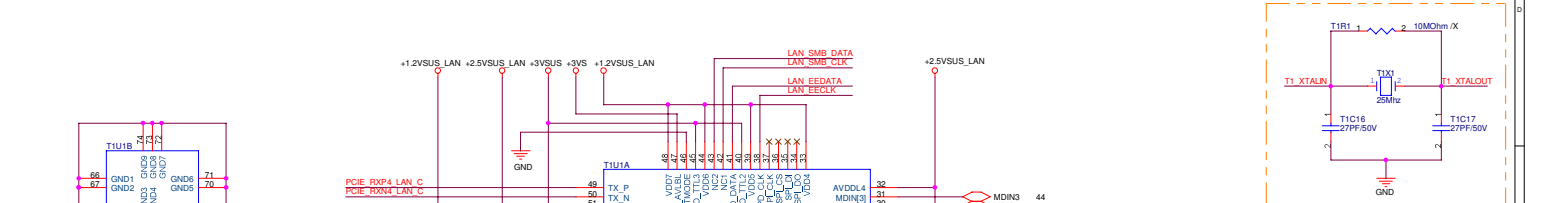
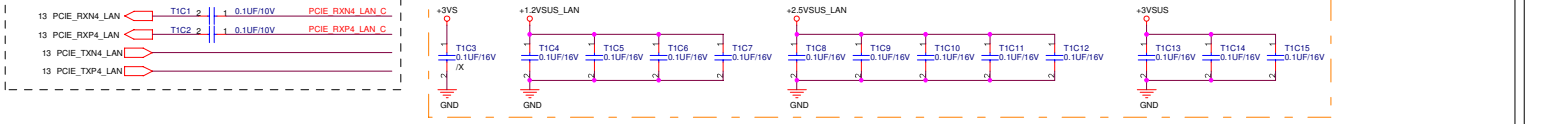

Pin to Pin Compatible with 88E8056
ASUS P/N: 02G751006700

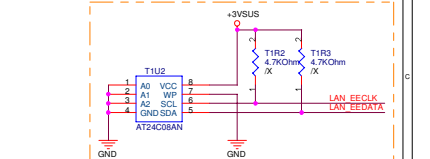
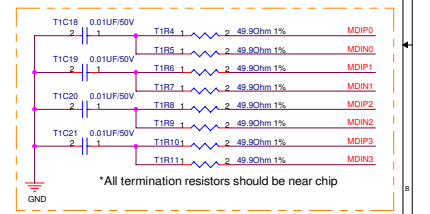
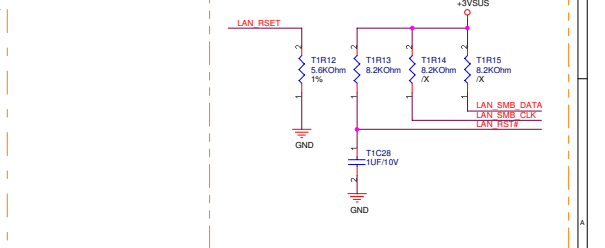
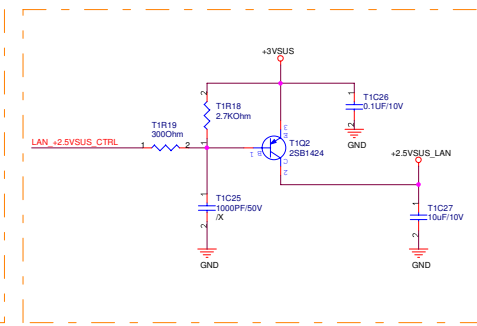
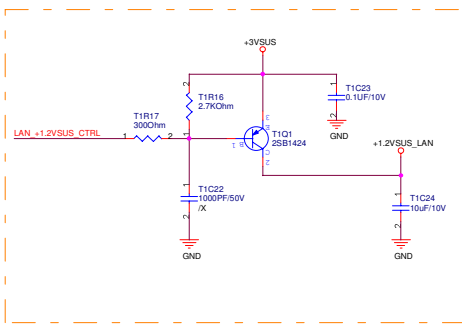

ASUS		Title : LAN 88E8053
ASUSTek Computer INC.		Engineer: Jack Hsu
Size	Project Name	Rev
Custom	Z84J	1.1
Date: 11/11/2008	Sheet	30 of 38

<< Kennedy_Zhang >>

ESATA Connector

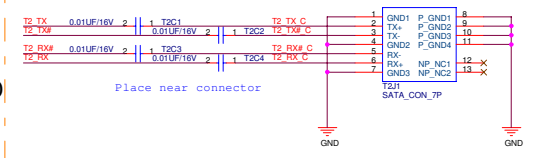

XTAL

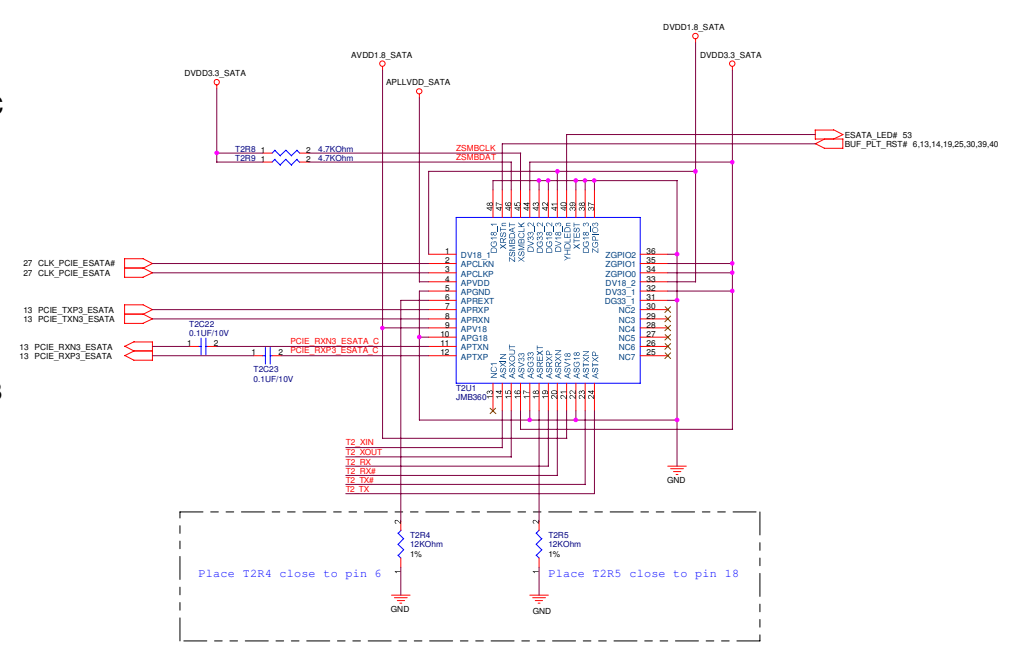
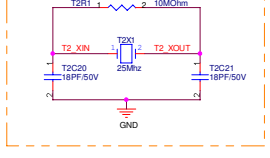

Place T2R4 close to pin 6
Place T2R5 close to pin 18

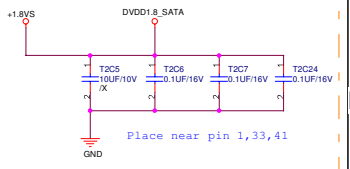

Place near pin 1,33,41

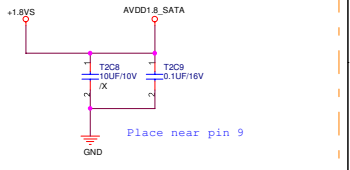

Place near pin 9

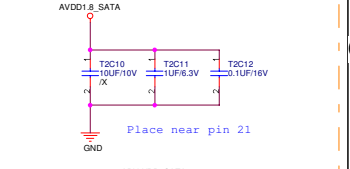

Place near pin 21

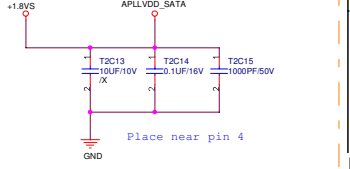

Place near pin 4

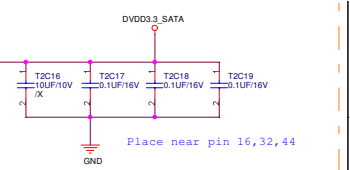

Place near pin 16,32,44

ASUS		Title : ESATA JMB360	
ASUSTek Computer INC.		Engineer: Jack Hsu	
Size	Project Name	Rev	
Custom	Z84J	1.1	
Date: 11/11/11 9:25:06	Sheet: 91	of	99

« Kennedy_Zhang »

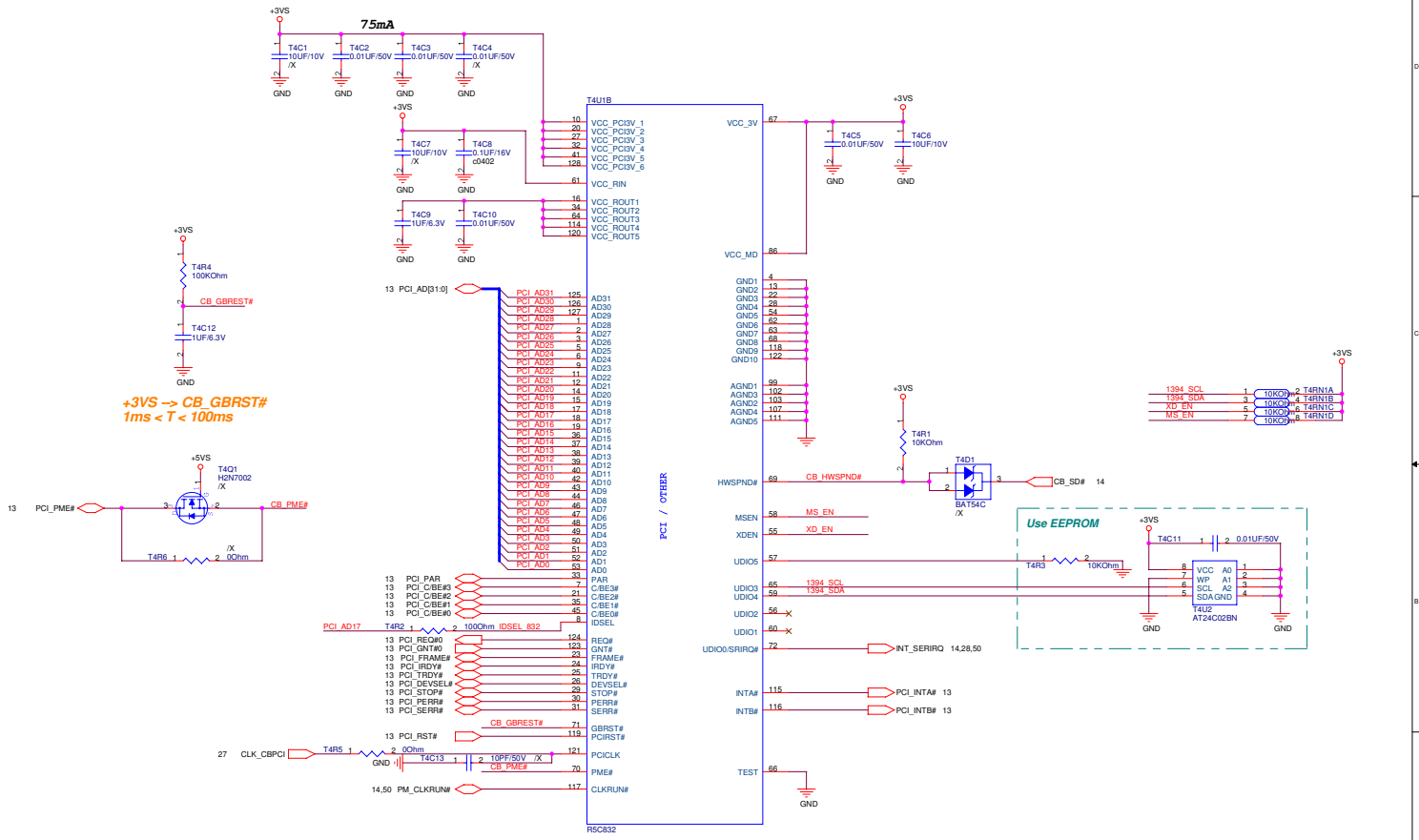

<Variant Name>

ASUS		Title :R5C832 PCI	
ASUSTek Computer INC.		Engineer: Jack Hsu	
Size	Project Name	Rev	
Custom	Z84J	1.1	
Date: 11/11/2006	Sheet: 66	of	66

<< Kennedy_Zhang >>

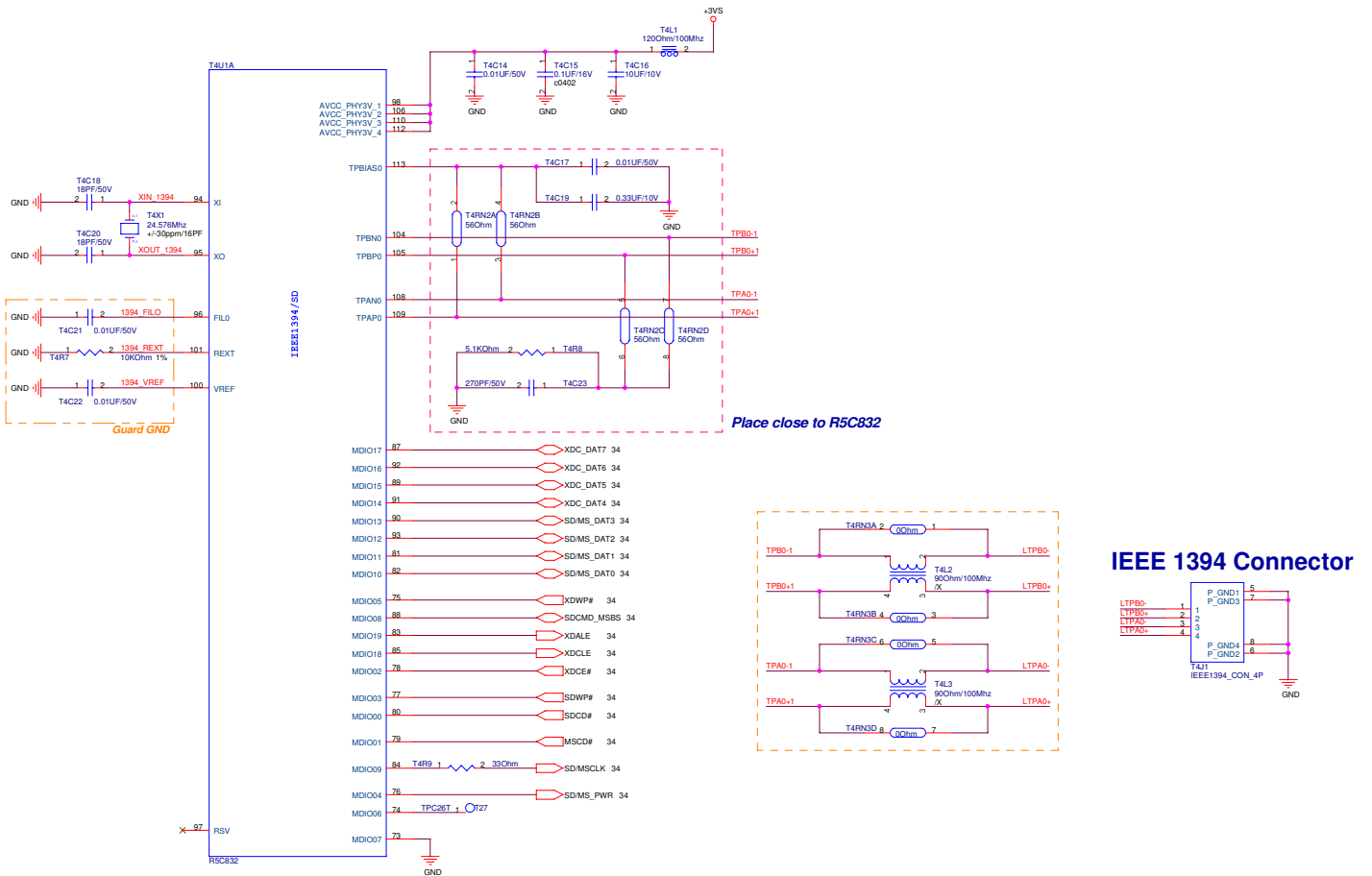

IEEE 1394 Connector

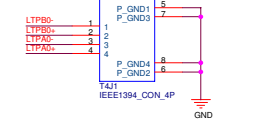

<Variant Name>

ASUS		Title : R5C832_1394/SD	
ASUSTek Computer INC.		Engineer: Jack Hsu	
Size	Project Name		Rev
Custom	Z84J		1.1
Date: 01/01/2006		Sheet: 03	of 08

<< Kennedy_Zhang >>

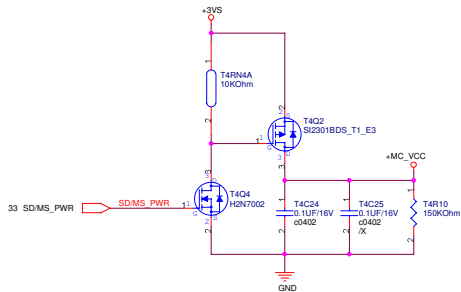

Card Reader Power Switch

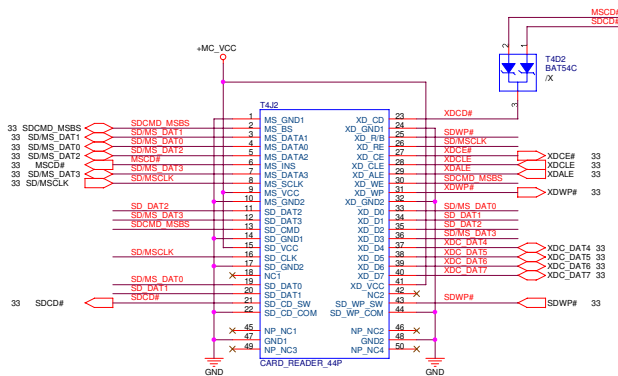
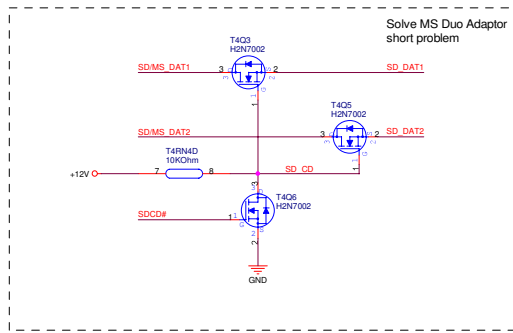

4 in 1 Card Reader

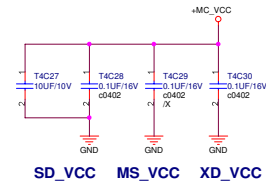

SD_VCC MS_VCC XD_VCC

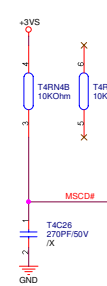

<Variant Name>

ASUS		Title 4 in 1 Card Reader	
ASUSTek Computer INC.		Engineer: Jack Hsu	
Size	Project Name	Rev	
Custom	Z84J	1.1	
Date: 11/11/2005	Sheet 34 of 38		

<< Kennedy_Zhang >>

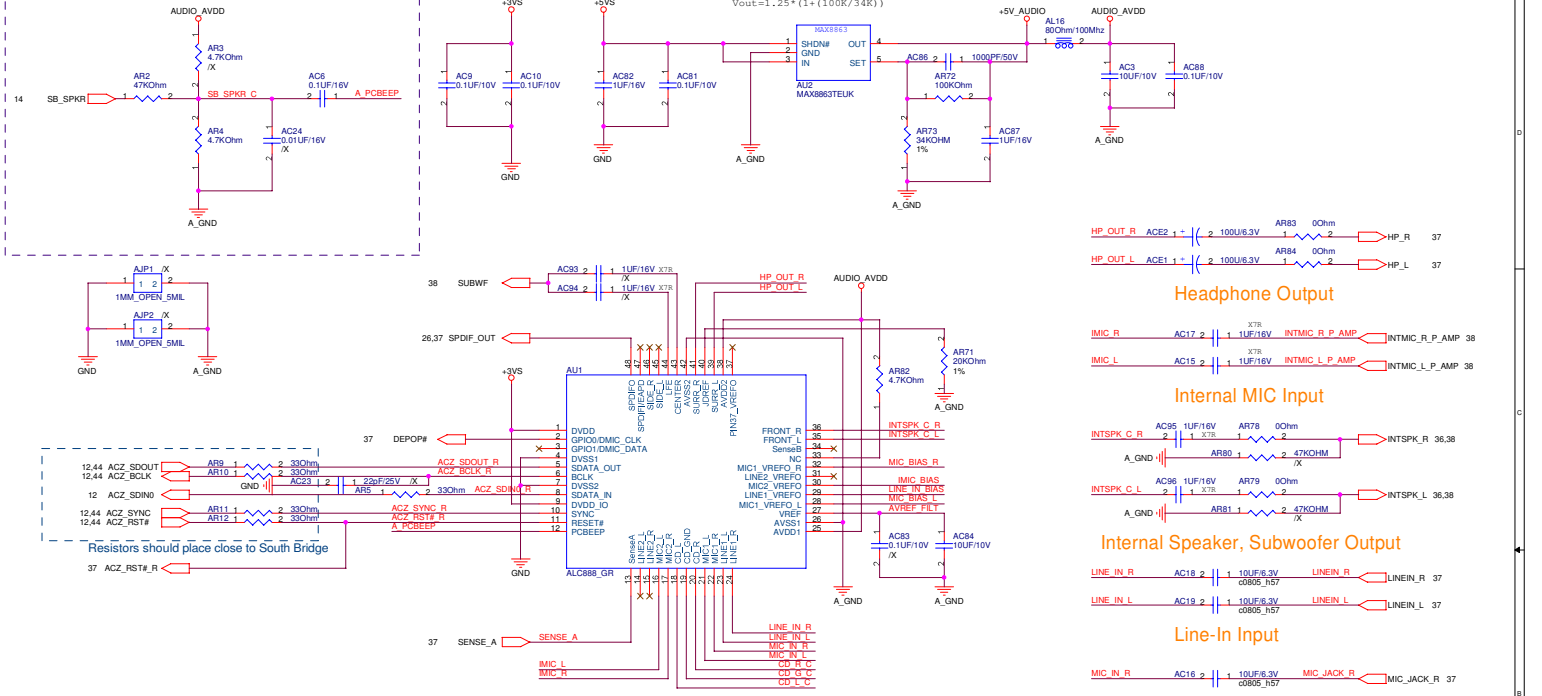

ASUS P/N: 02G611002900, 02G611002910

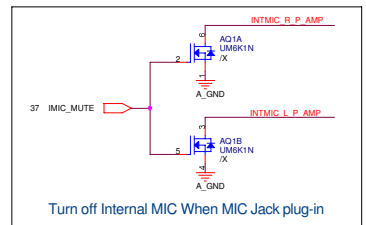
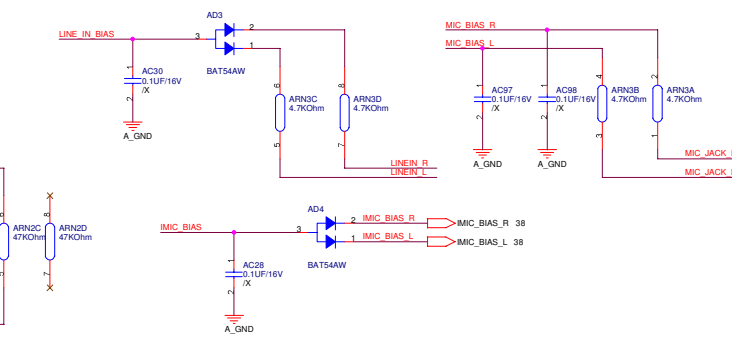
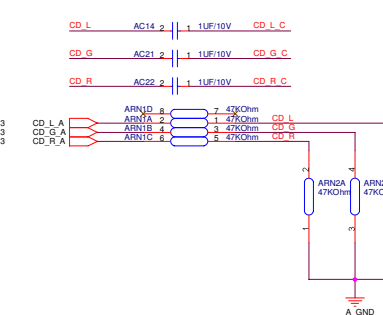

ASUS		Title : Audio ALC882H	
ASUSTek Computer, INC.		Engineer: Jack Hsu	
Size	Project Name	Rev	
Custom	Z84J	1.1	
Date: 11/19/2006	Sheet 35 of 38		

<< Kennedy_Zhang >>

GAIN Control

GAIN1	GAIN0	Gain
0	0	0dB
0	1	10dB
1	0	15.8dB
1	1	21.6dB

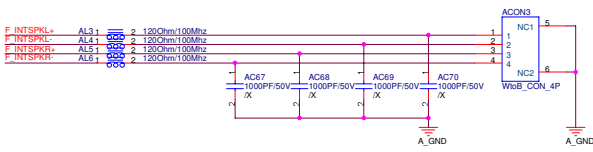
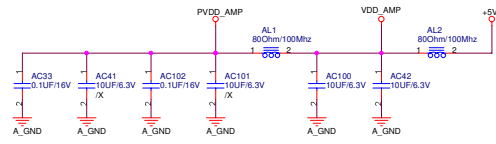
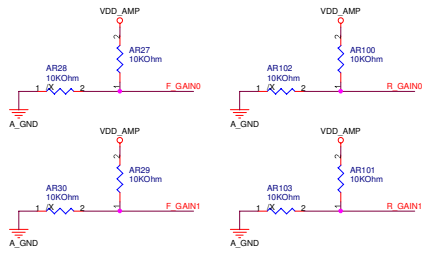

FRONT Speaker Connector

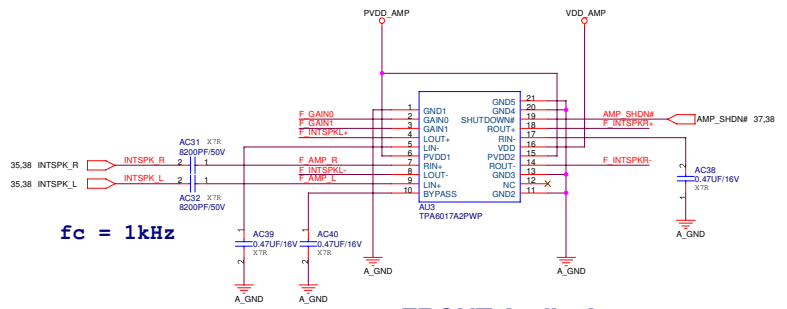

FRONT Audio Amp.

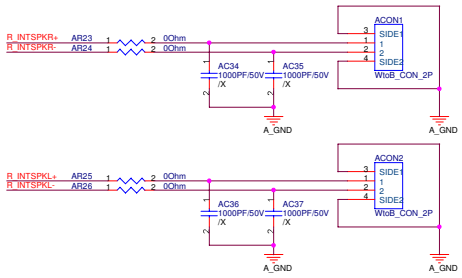

REAR Speaker Connector

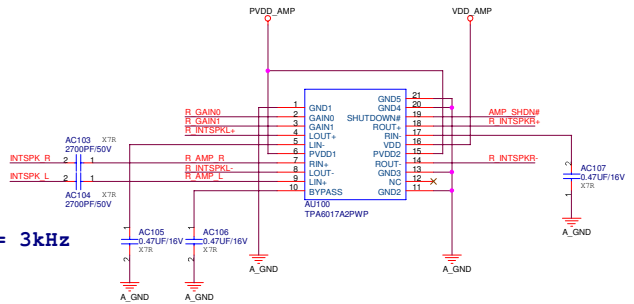

REAR Audio Amp.

ASUS Title : Audio Amp. & Conn
 ASUSTek Computer INC. Engineer: Jack Hsu
 Size Project Name
 Custom Z84J Rev 1.1
 Date: 08/11/2006 Sheet 36 of 60

<< Kennedy_Zhang >>

Headphone & S/PDIF Jack

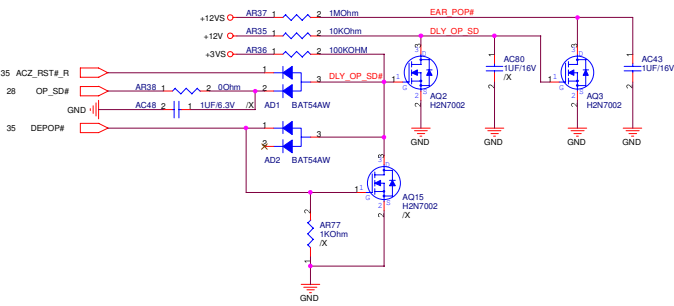
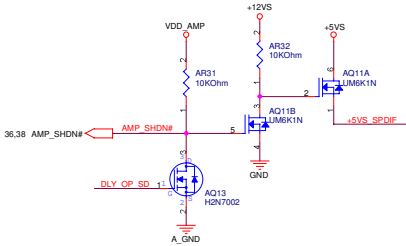
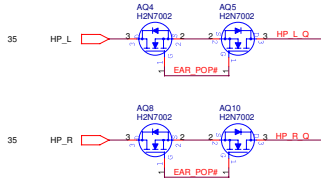
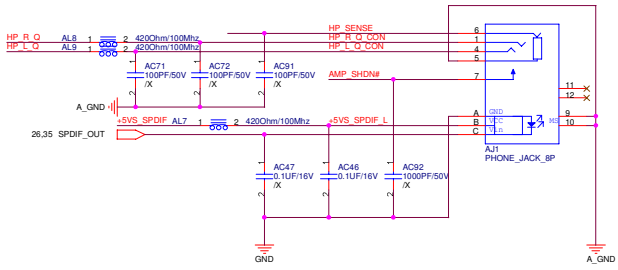

Line-In Jack

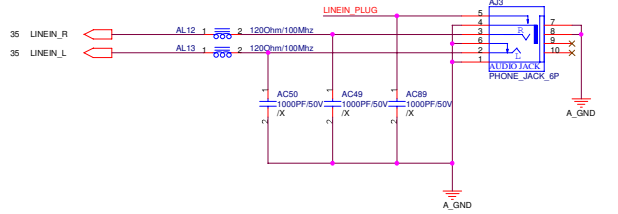

Microphone-In Jack

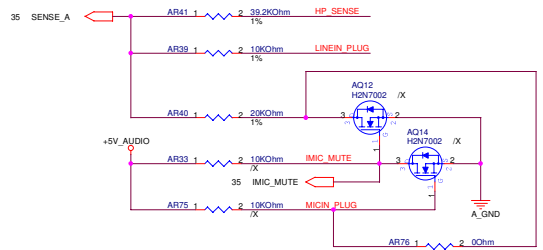
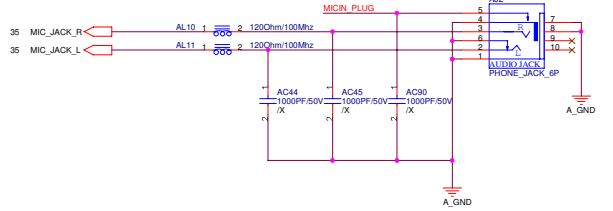

Jack Plug-in Detection

ASUS		Title : Audio JACK
ASUSTek Computer INC.		Engineer: Jack Hsu
Size	Project Name	Rev
Custom	Z84J	1.1
Date: 11/11/19, 2008	Sheet	37 of 69

« Kennedy_Zhang »

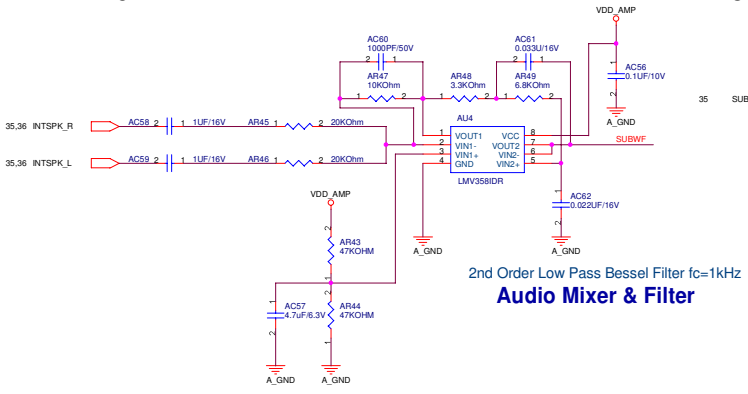

2nd Order Low Pass Bessel Filter $f_c=1\text{kHz}$
Audio Mixer & Filter

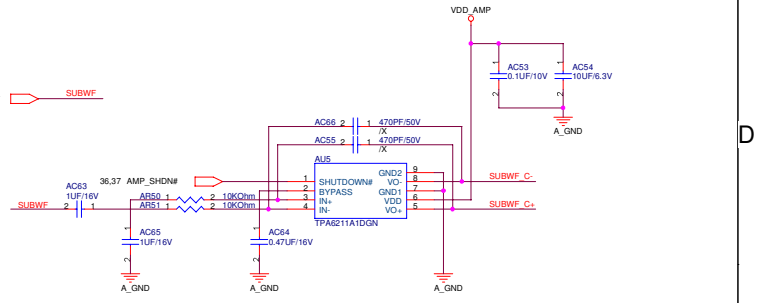

Subwoofer Amp.
 Input Pass Band : 20Hz~1kHz

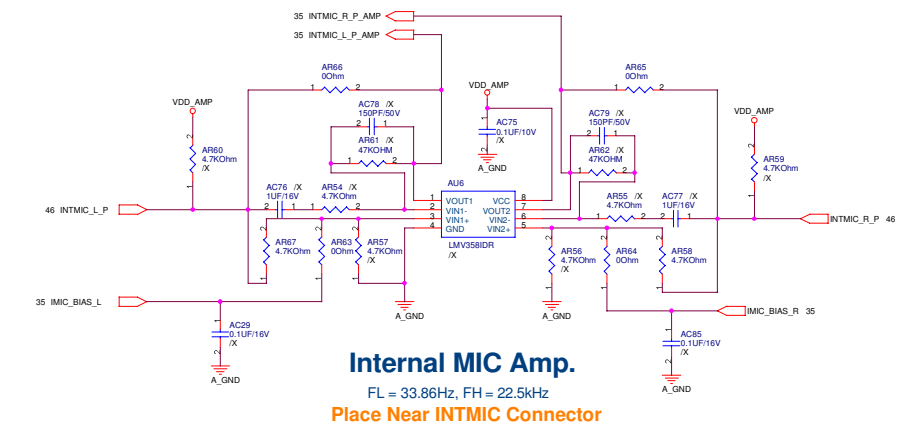

Internal MIC Amp.
 FL = 33.86Hz, FH = 22.5kHz
 Place Near INTMIC Connector

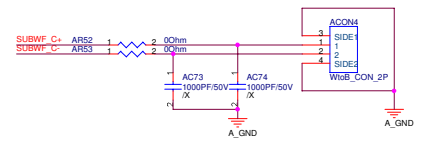

ASUS		Title : Subwoofer Amp.	
ASUSTek Computer INC.		Engineer: Jack Hsu	
Size	Project Name	Rev	
Custom	Z84J	1.1	
Date: 11/11/2008		Sheet	38 of 68

« Kennedy_Zhang »

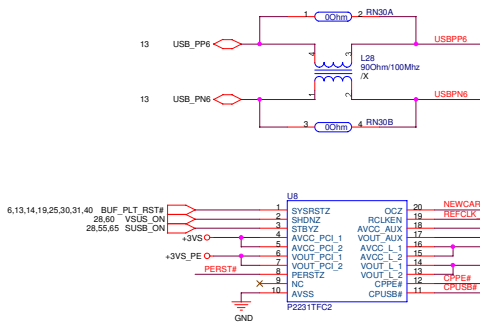

NewCard Header

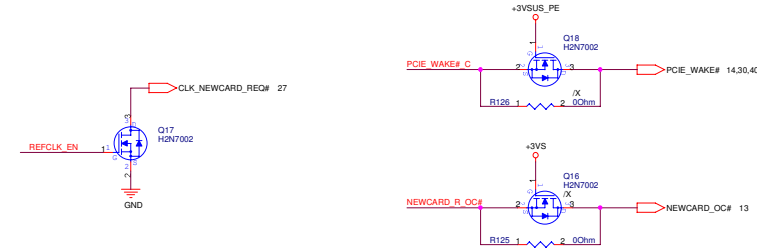
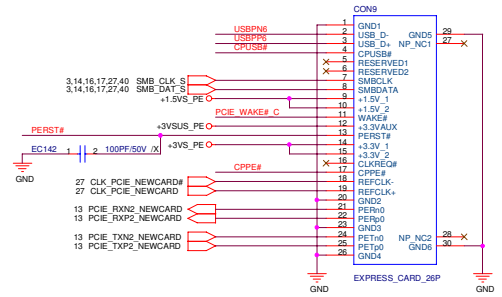

!! ExpressCard Standard 1.0:
 Change Pin7 from RESERVED to SMBCLK
 Change Pin8 from SMBCLK to SMBDATA
 Change Pin9 from SMBDATA to +1.5V

NewCard Ejector

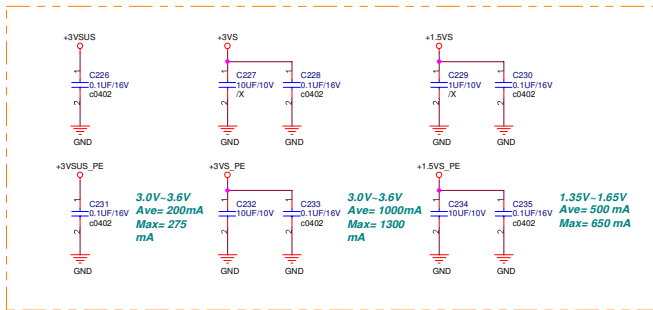
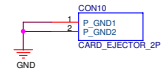

<Variant Name>

ASUS		Title : NEWCARD	
ASUSTek Computer INC.		Engineer: Jack Hsu	
Size	Project Name	Rev	
Custom	Z84J	1.1	
Date: 11/11/2006	Sheet: 09	of 09	

<< Kennedy_Zhang >>

MINICARD For TV-Tuner

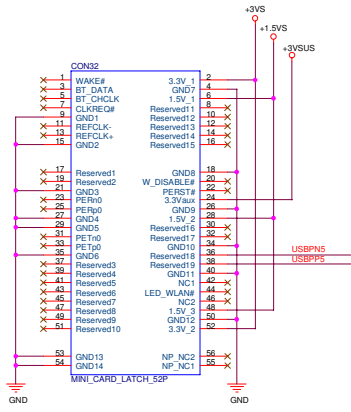

USB ONLY H = 6.75mm

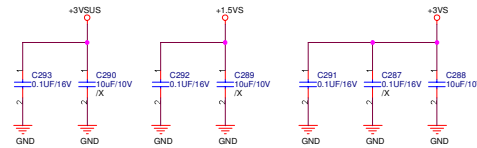
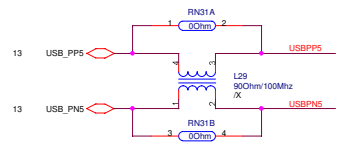

Title : MINICARD-2	
ASUSTek Computer INC.	Engineer: Jack Hsu
Size : Project Name:	Rev : 1.1
Custom : Z84J	Date: 11/13/2008
Sheet 41 of 68	

<< Kennedy_Zhang >>

SATA HDD Connector

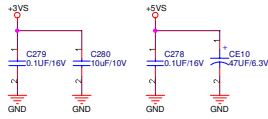
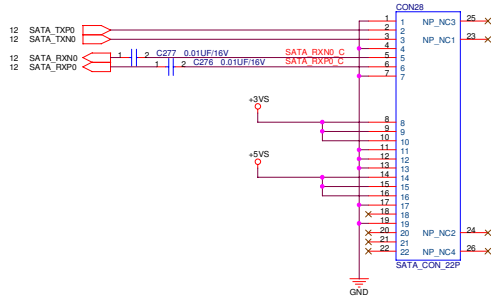

<Variant Name>		ASUS Title : SATA HDD Conn.	
ASUSTek Computer INC.		Engineer: Jack Hsu	
Size	Project Name	Rev	1.1
Custom	Z84J	Date	11/31/2008
Sheet 42 of 68			

<< Kennedy_Zhang >>

ODD Connector

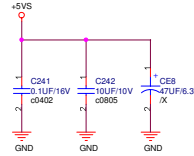
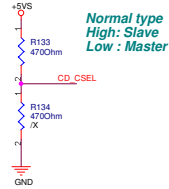
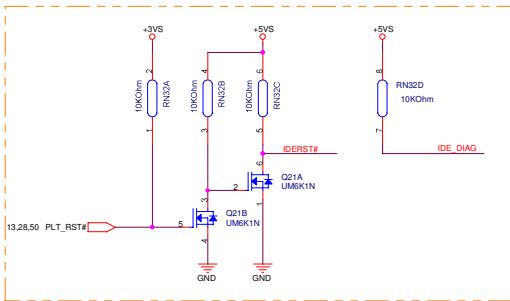
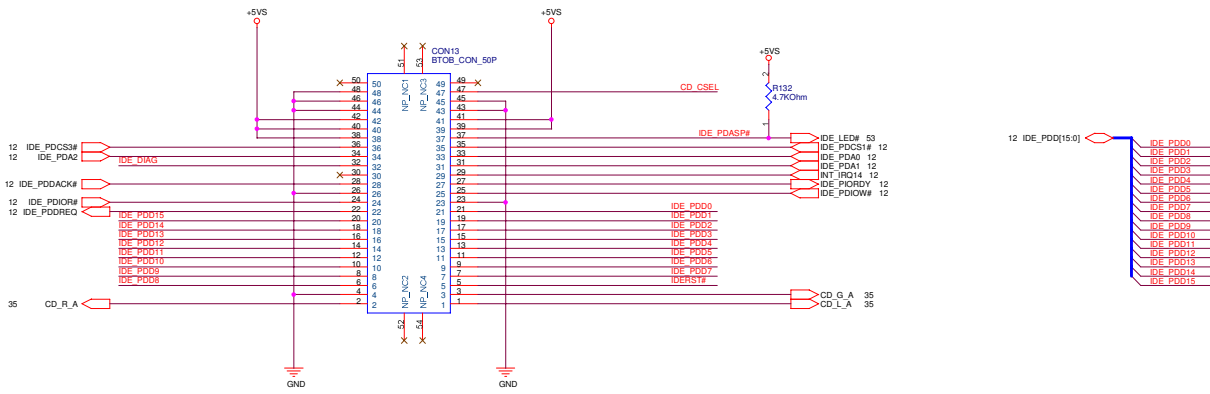

ASUS
ASUSTek Computer INC. Title : ODD Connector
Engineer: Jack Hsu

Size	Project Name	Rev
Custom	Z84J	1.1
Date: 11/11/2006	Sheet: 43	of 68

<< Kennedy_Zhang >>

MDC Connector

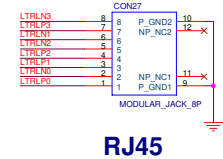
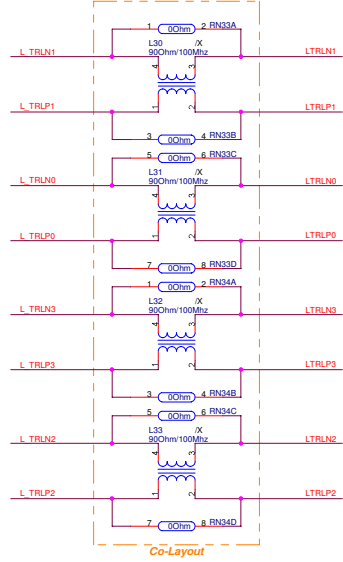
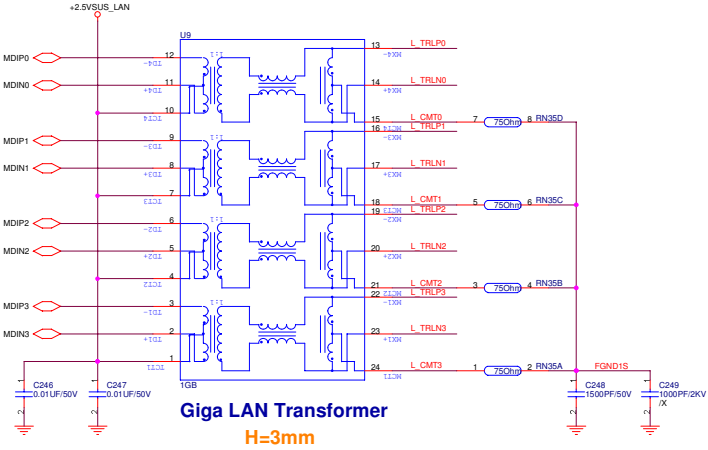
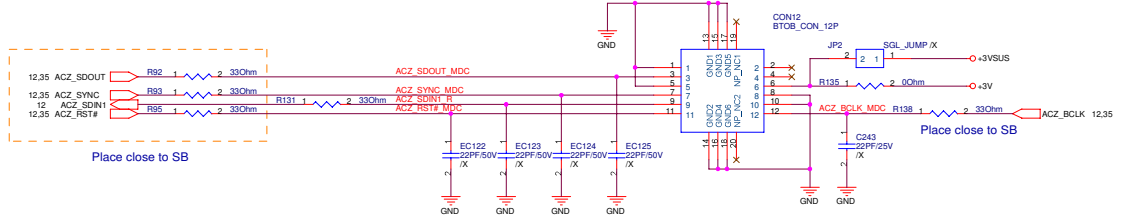

ASUS
ASUSTek Computer INC. Title: MDC RJ45 RJ11
Engineer: Jack Hsu

Size	Project Name	Rev
Custom	Z84J	1.1
Date: 2008.11.11	Sheet: 44	of 68

<< Kennedy_Zhang >>

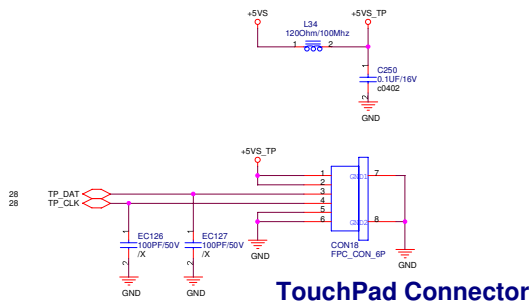

TouchPad Connector

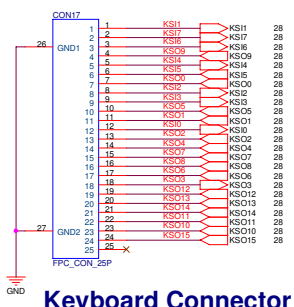

Keyboard Connector

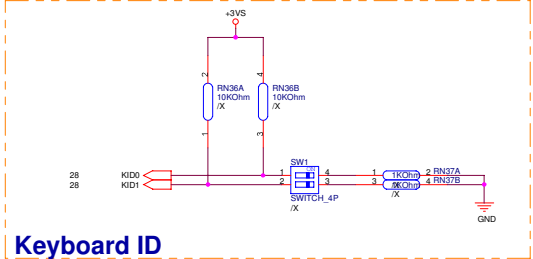
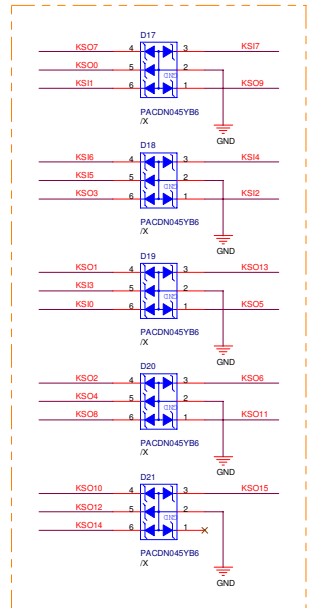

Keyboard ID

<Variant Name>

ASUS		Title : Touch Pad & KB
ASUSTek Computer INC.		Engineer: Jack Hsu
Size	Project Name	Rev
Custom	Z84J	1.1
Date: 11/11/2006	Sheet 45 of 58	

<< Kennedy_Zhang >>

Camera & Internal MIC Connector

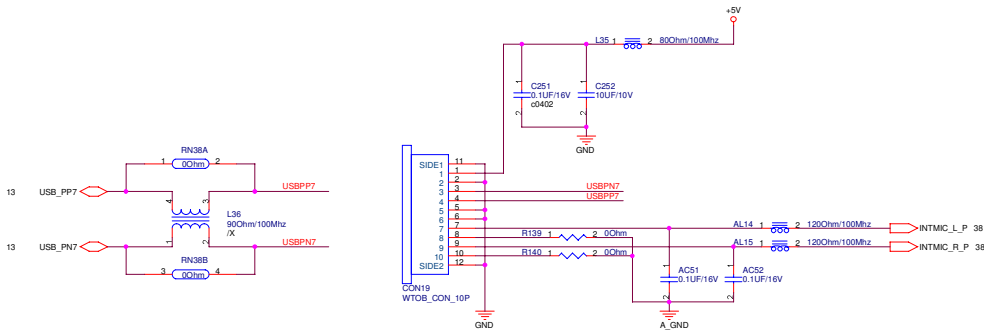

ASUS		Title : Camera Conn.	
ASUSTek Computer INC.		Engineer: Jack Hsu	
Size	Project Name	Rev	
Custom	Z84J	1.1	
Date: 11/11/2009	Sheet 36 of 69		

« Kennedy_Zhang »

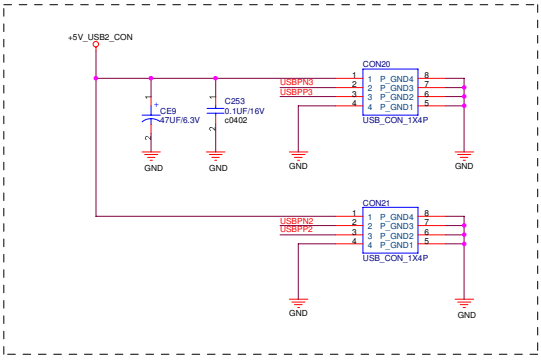
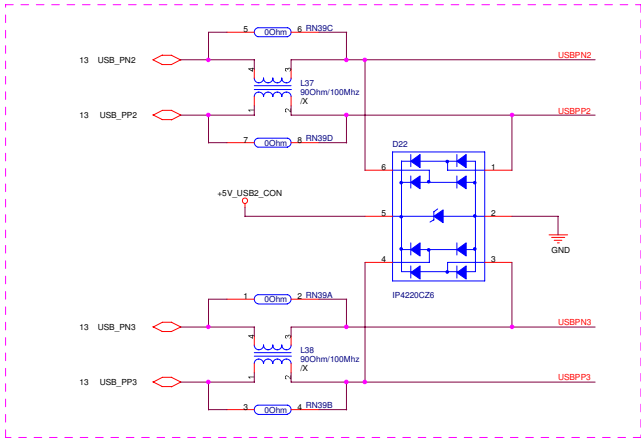

On-board USB Connector

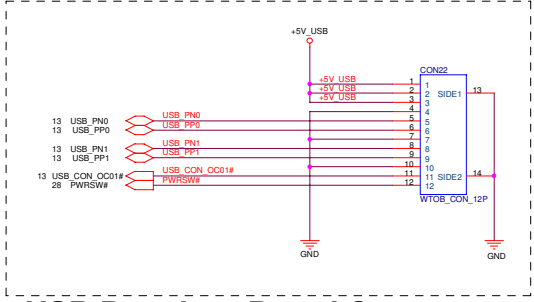
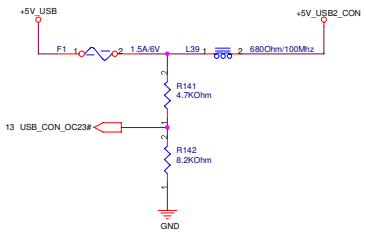

USB Daughter Board Connector

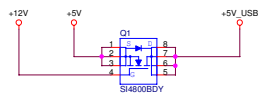

<Variant Name>

ASUS		Title : USB Connector
ASUSTek Computer INC.		Engineer: Jack Hsu
Size	Project Name	Rev
Custom	Z84J	1.1
Date: 11/11/2006	Sheet: 47	of 68

<< Kennedy_Zhang >>

Bluetooth Connector

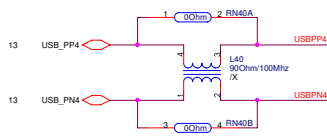
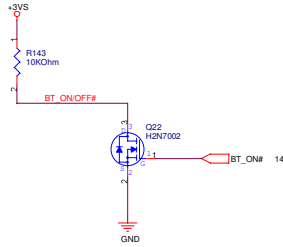
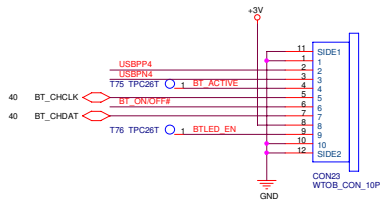

<Variant Name>

ASUS		Title : Bluetooth Conn.	
ASUSTek Computer INC.		Engineer: Jack Hsu	
Size	Project Name		Rev
Custom	Z84J		1.1
Date: 01/11/2009		Sheet: 48	of 68

<< Kennedy_Zhang >>

Debug Connector

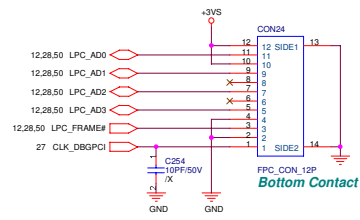

<Variant Name>

ASUS		Title : Debug Connector	
ASUSTek Computer INC.		Engineer: Jack Hsu	
Size	Project Name		Rev
Custom	Z84J		1.1
Date: 01/11/2006		Sheet: 49	of 68

<< Kennedy_Zhang >>

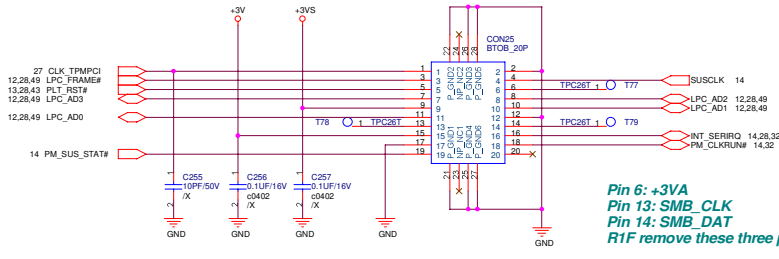

Pin 6: +3VA
 Pin 13: SMB_CLK
 Pin 14: SMB_DAT
 R1F remove these three pins to reduce pin numbers!

TPM Module Connector

<Variant Name>

		Title : TPM Connector	
ASUSTek Computer INC.		Engineer: Jack Hsu	
Size	Project Name		Rev
Custom	Z84J		1.1
Date: 01/11/2006		Sheet: 50	of 50

<< Kennedy_Zhang >>

CPU Thermal Sensor

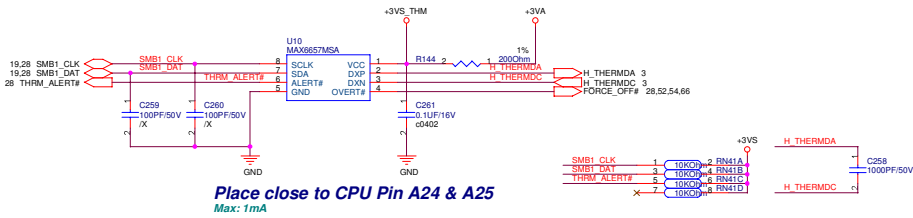

Place close to CPU Pin A24 & A25
Max: 1mA

Route H_THERMDA and H_THERMDC in the same layer

15 mils ----- OTHER SIGNALS
----- GND
10 mils ----- H_THERMDA(10 mils)
10 mils ----- H_THERMDC(10 mils)
----- GND
15 mils ----- OTHER SIGNALS

Avoid FSB Power

System Fan Connector

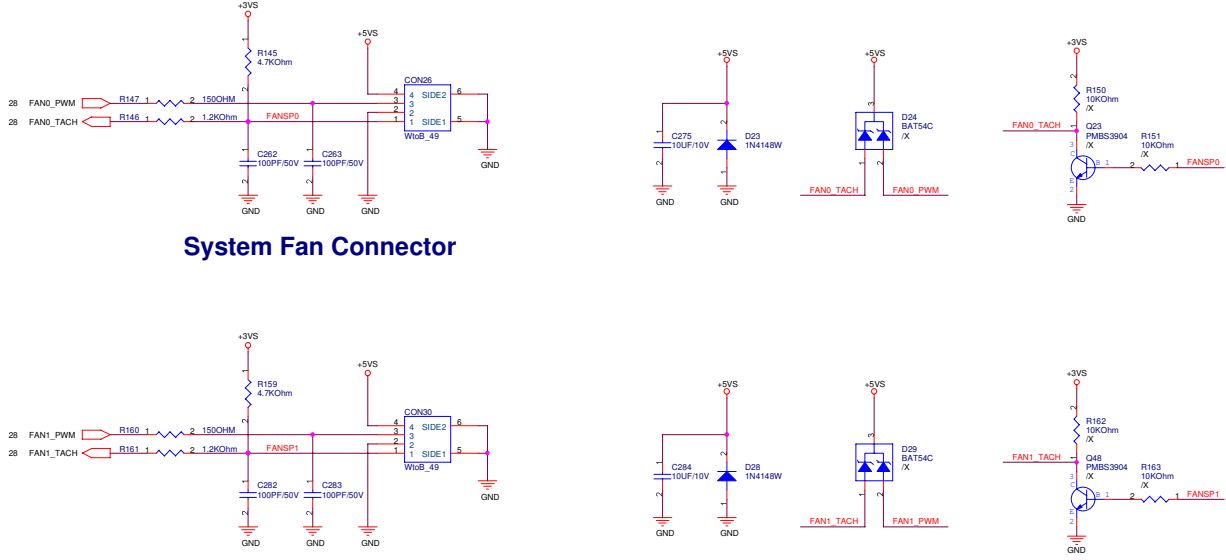

VGA Fan Connector

CPU FAN will be forced on:
1) Thermal Sensor Over-temperature
2) WATCHDOG asserted by EC

ASUS		Title : Thermal Sensor & Fan	
ASUSTeK Computer INC.		Engineer: Jack Hsu	
Size	Project Name		Rev
Custom	Z84J		1.1
Date: 11/11/2006	Sheet: 01	of 08	

<< Kennedy_Zhang >>

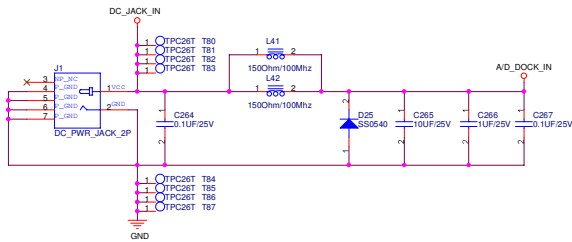

DC-IN Connector

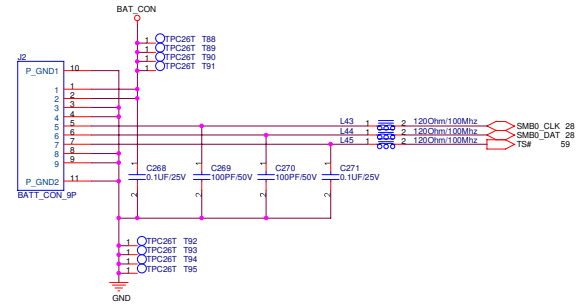

BAT-IN Connector

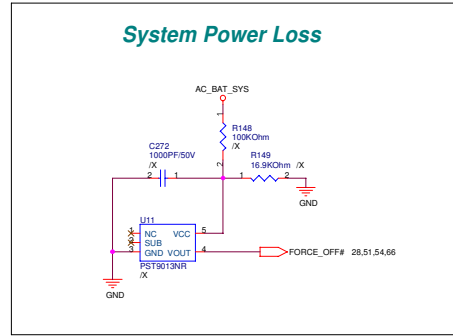

-Variant Name-

ASUS		Title : DC IN & BAT IN	
ASUSTek Computer INC.		Engineer: Jack Hsu	
Size	Project Name		Rev
Custom	Z84J		1.1
Date: 11/11/2009		Sheet: 59	of 68

<< Kennedy_Zhang >>

LED

POWER LED

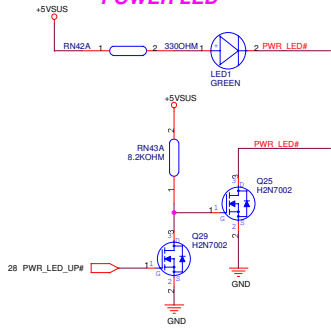

BATTERY CHARGE LED

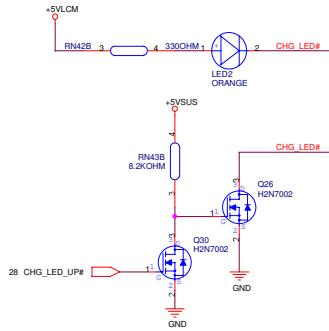

EMAIL LED

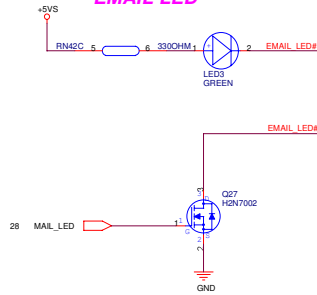

Wireless Bluetooth LED

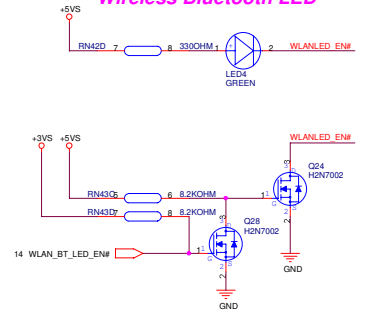

ESATA/SATA/IDE LED

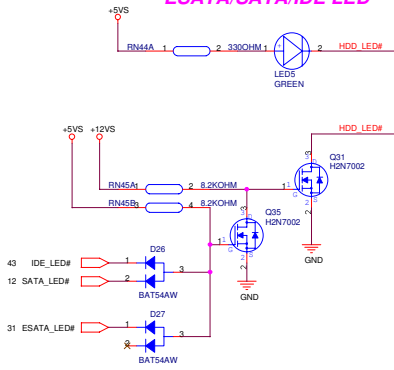

Num Lock LED

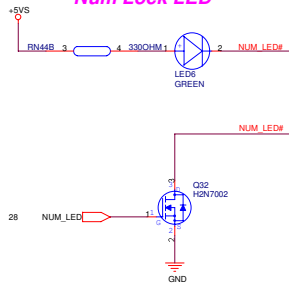

Cap Lock LED

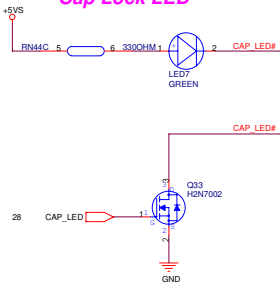

Scroll Lock LED

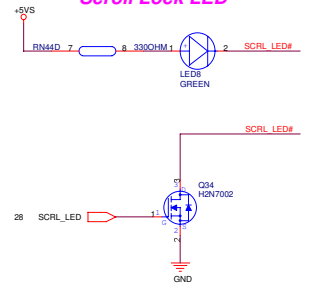

<-Variant Name>

		Title : LED	
ASUSTek Computer INC.		Engineer: Jack Hsu	
Size	Project Name		Rev
Custom	Z84J		1.1
Date: 01/11/2006		Sheet: 03	of 08

<< Kennedy_Zhang >>

Internet

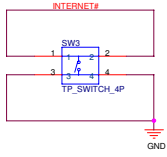

Email

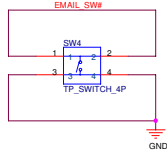

TouchPad Disable

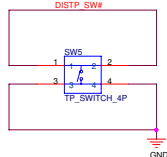

Power4G

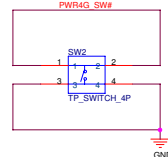

System Reset

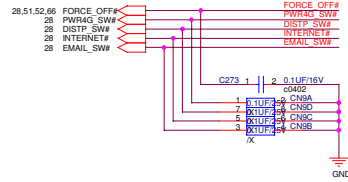
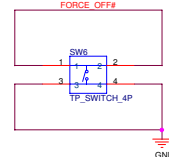

<Variant Name>

		Title :Switch Button	
ASUSTek Computer INC.		Engineer: Jack Hsu	
Size	Project Name		Rev
Custom	Z84J		1.1
Date: 01/11/2006		Sheet: 54	of 68

<< Kennedy_Zhang >>

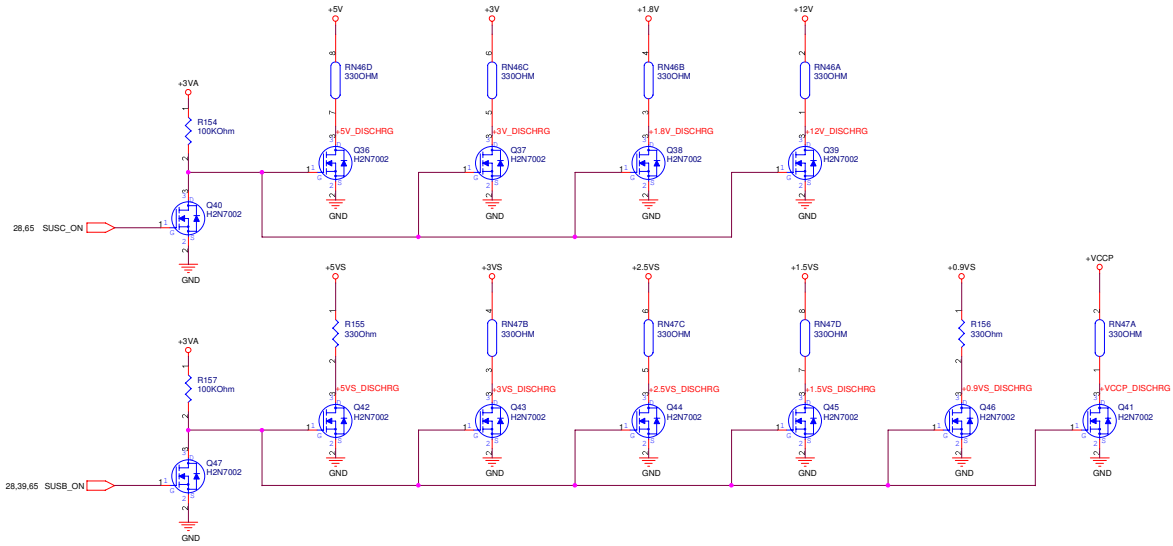

<Variant Name>

ASUS		Title : Discharger
ASUSTek Computer INC.		Engineer: Jack Hsu
Size	Project Name	Rev
Custom	Z84J	1.1
Date: 01/11/2006	Sheet: 55	of 68

<< Kennedy_Zhang >>

CPU Thermal Housing

North Bridge Thermal Housing

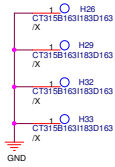

MDC Nut



TPM Nut



Mini Card Nut



System Fan Nut



MXM



System Nut



TV-Tuner Nut

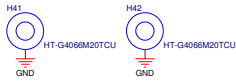

PTH HOLE



NPTH HOLE

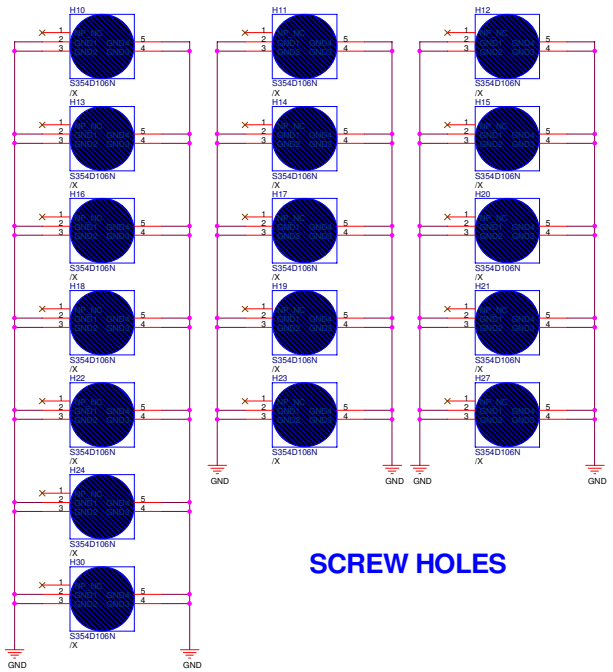

SCREW HOLES

System Fan Screw hole

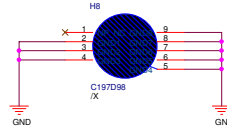

EMI PAD

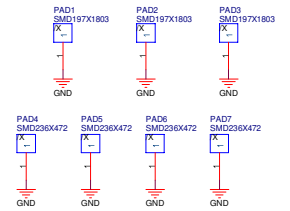

<Variant Name>

ASUS		Title : Screw Hole	
ASUSTek Computer INC.		Engineer: Jack Hsu	
Size	Project Name		Rev
Custom	Z84J		1.1
Date: 11/11/2006	Sheet: 56	of 68	

<< Kennedy_Zhang >>

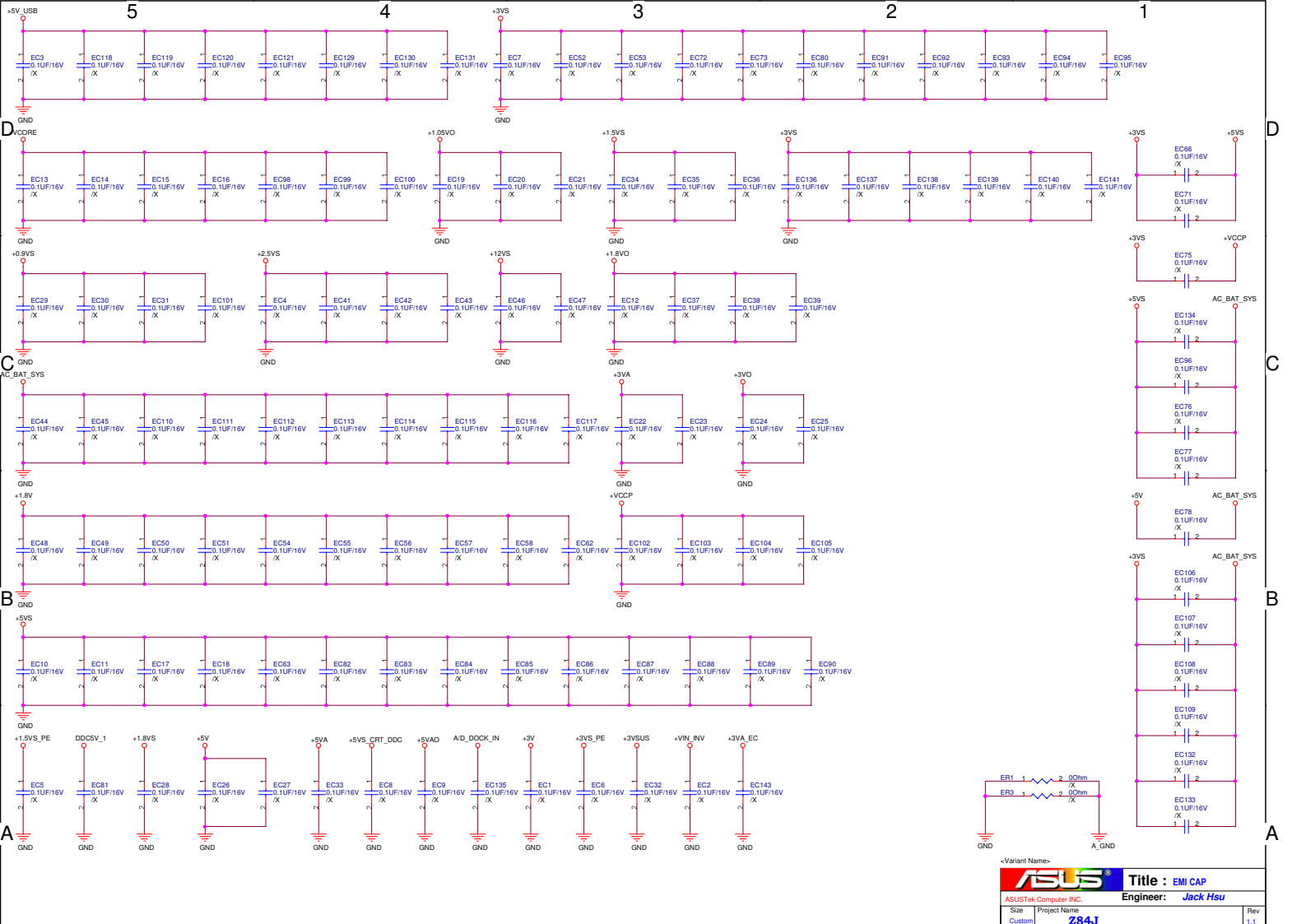

4 << Kennedy_Zhang >> 2

ASUS		Title : EMI CAP	
ASUSTek Computer INC.		Engineer: Jack Hsu	
Size	Project Name	Rev	1.1
Custom	Z84J	Date	11/16/2008
		Sheet	57 of 68

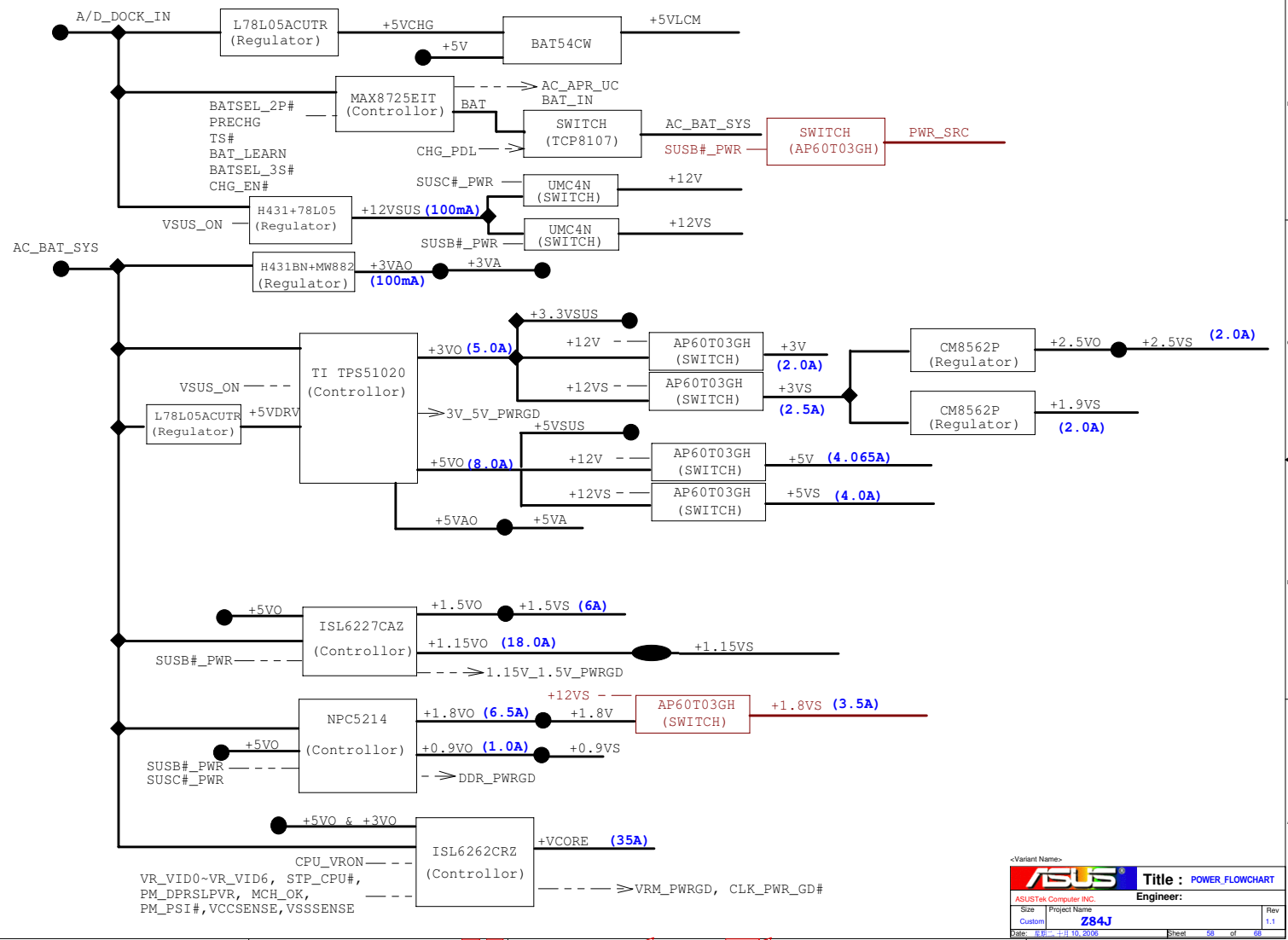

<Variant Name>

ASUS		Title : POWER_FLOWCHART	
ASUSTek Computer INC. Engineer:			
Size	Project Name		Rev
Custom	Z84J		1.1
Date: 11/16/2006	Sheet 58	of 68	

<< Kennedy_Zhang >>

Setting the Adapter Input Current Limit

Adapter I_{in}(max) = [0.075V/Rsense(AD_{IN})]/[VCLSLVREF]
 VCLSLV = 2.865V
Adaptor Max. Current :
 PR5708=20K PR5714 = 173K; I_{limit} = 4.5A; 81W
 PR5708=27K PR5714 = 47K; I_{limit} = 3.175A; 60W

Setting the Charge Voltage

V_{batt} = Cell * { V_{ref} + [(VCTL - 1.8V) / 9.52] }
 VCTL = 1.588V => V_{batt} = 4.2V

Setting the Charge Current

Charge Current I_{chg} = [0.075V/Rsense(CHG)]/[VCTL0.6V]
 Rsense(CHG) = 15m Ohm
Pre-Charging Mode :
 Precharging current = 148 - 152mA
 Vctl = 0.107V - 0.109V

Battery Cell Selection :

BATSEL_2P# = 1, 3 Cells; Vctl = 2.084V
 => I_{charge} = 1.6933A
 BATSEL_2P# = 0, 6 or 9 Cells; Vctl = 2.111V
 => I_{charge} = 2.9328A
 PR5709=120K PR5715 = 120K; I_{charge} = 2.9328A

Mode pin : V_{mode} > 2.8V (try to LDO pin) -> 4 Cells
 2.0 > V_{mode} > 1.6V (floating) -> 3 Cells
 0.8 > V_{mode} (tie to GND) -> Learning mode
 VCTL < 0.8V or DCIN < 7V -> Charger Disable

MAX8725_REF : 4.2235V
 MAX8725_LDO : 5.4V

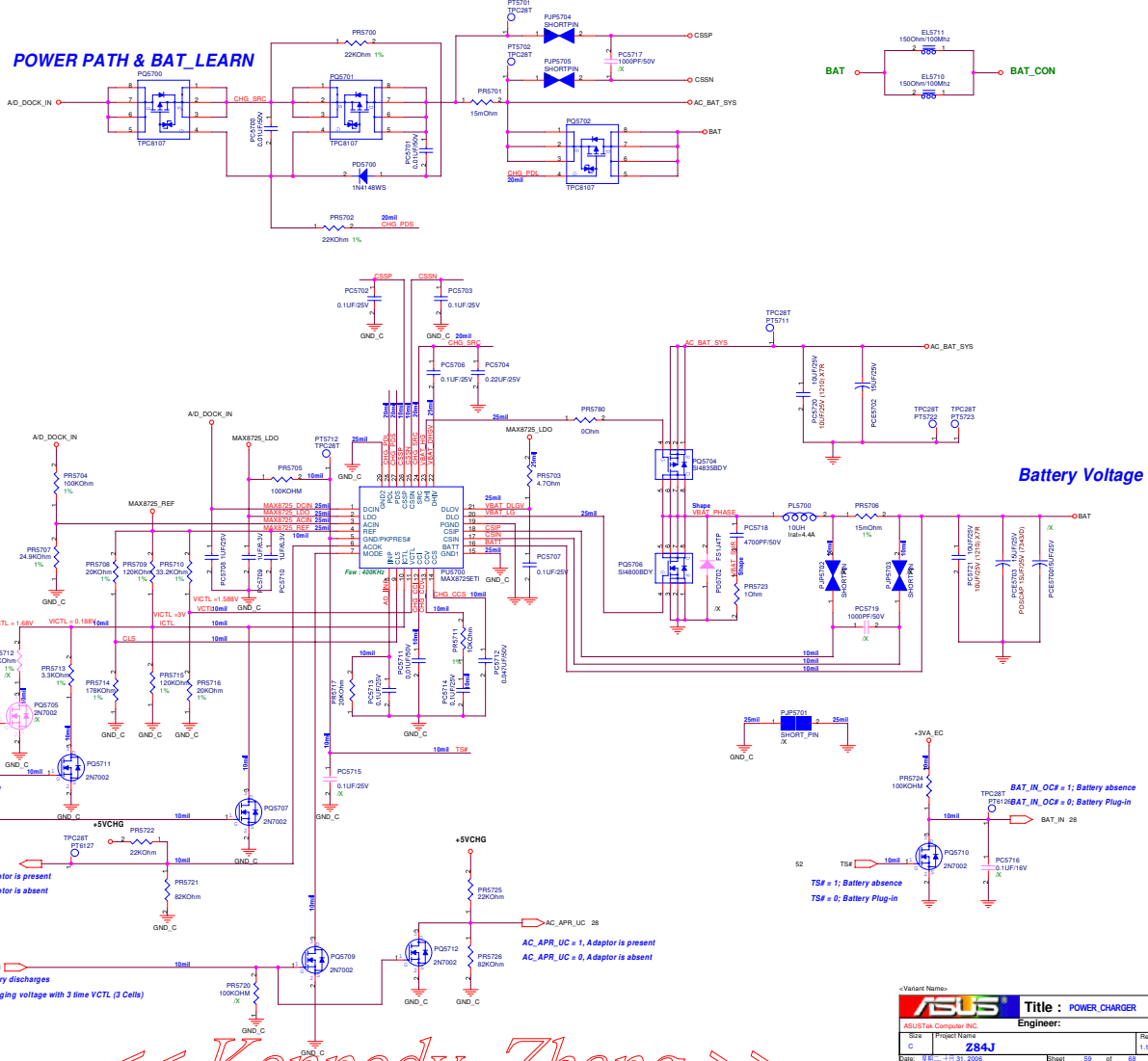

AC_OK = 1, Adaptor is present
 AC_OK = 0, Adaptor is absent

BAT_LEARN = 1, Battery discharges
 BAT_LEARN = 0, charging voltage with 3 time VCTL (3 Cells)

TS# = 1; Battery absence
 TS# = 0; Battery Plug-in

« Kennedy_Zhang »

ASUS		Title : POWER CHARGER	
ASUSTek Computer, Inc.	Project Name :	Engineer :	
C	284J	Rev : 1.1	
Date : 11-07-2008	Sheet : 58	of 68	

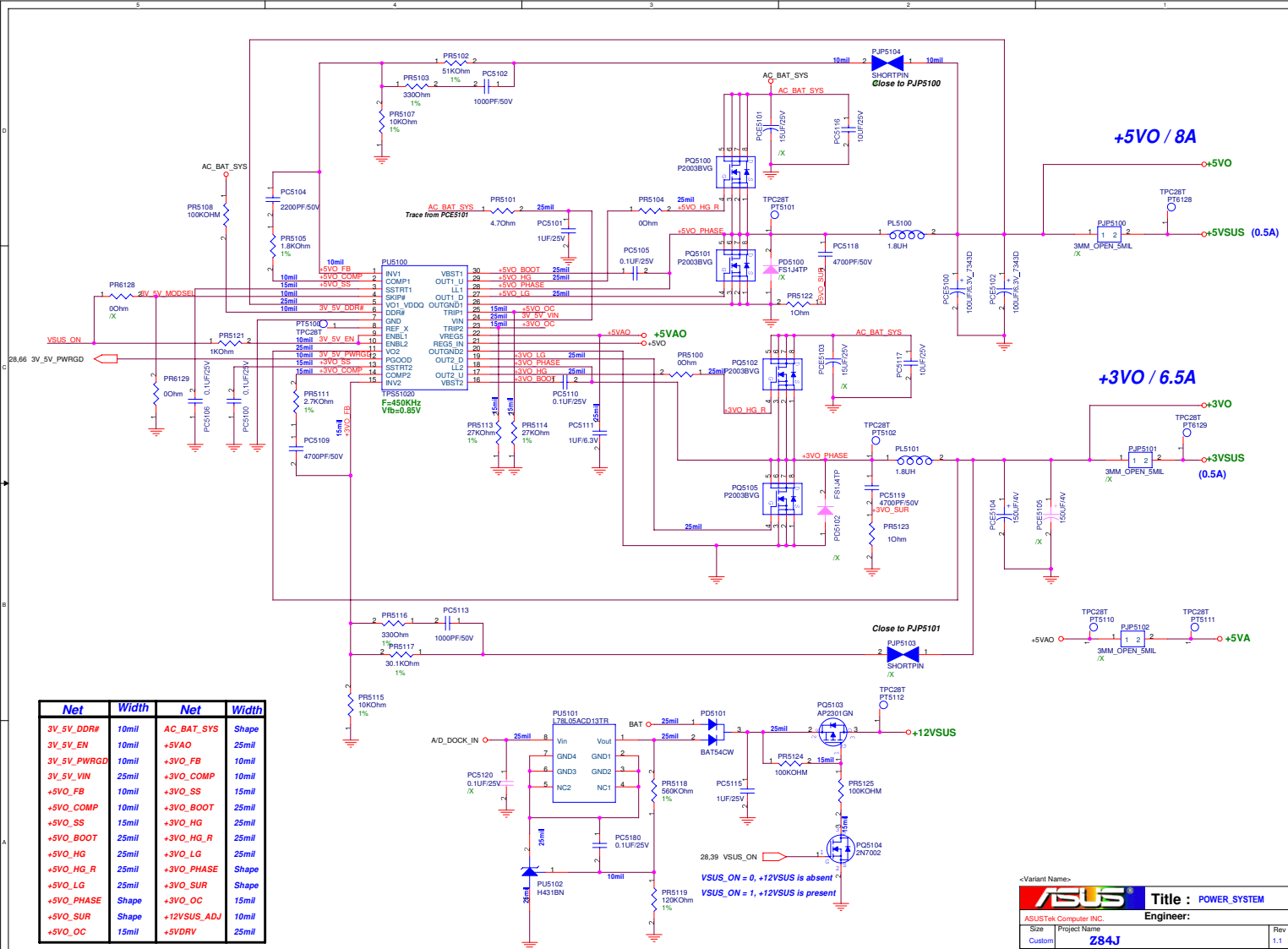

<Variant Name>

ASUS		Title : POWER_SYSTEM
ASUSTek Computer INC.	Project Name	Engineer :
Custom	Z84J	
Date: 08-31-2006	Sheet 60 of 88	Rev 1.1

<< Kennedy_Zhang >>

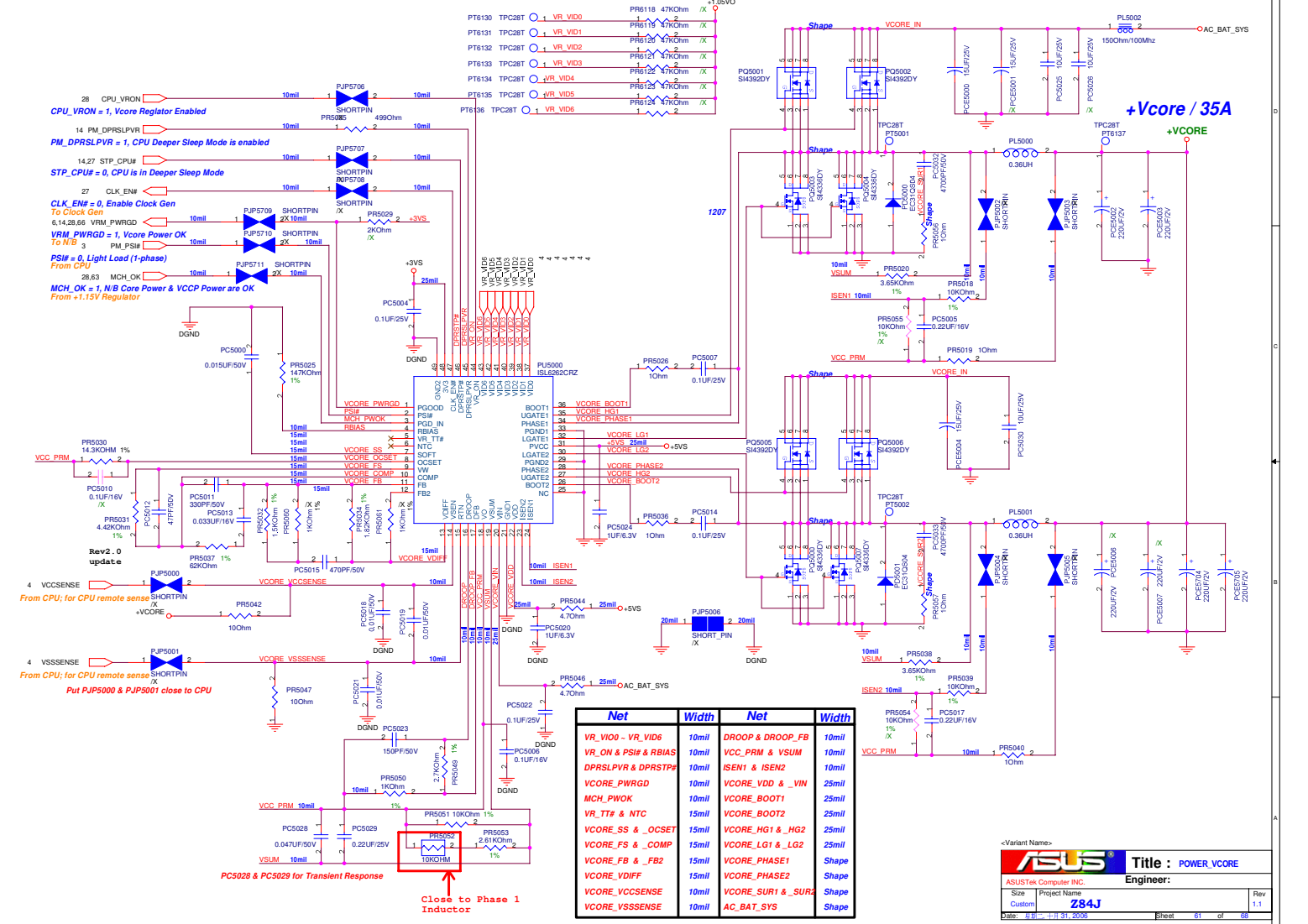

28 CPU_VRON = 1, Vcore Regulator Enabled
 CPU_VRON = 1, Vcore Regulator Enabled
 14 PM_DPRSLPVR = 1, CPU Deeper Sleep Mode is enabled
 PM_DPRSLPVR = 1, CPU Deeper Sleep Mode is enabled
 14.27 STP_CPU = 0, CPU is in Deeper Sleep Mode
 STP_CPU = 0, CPU is in Deeper Sleep Mode
 27 CLK_EN = 0, Enable Clock Gen
 CLK_EN = 0, Enable Clock Gen
 6.14.28.64 VRM_PWRGD = 1, Vcore Power OK
 VRM_PWRGD = 1, Vcore Power OK
 28.63 MCH_OK = 1, M/B Core Power & VCCP Power are OK
 MCH_OK = 1, M/B Core Power & VCCP Power are OK

4 VCCsense = 1, for CPU remote sense
 From CPU, for CPU remote sense
 4 VSSsense = 1, for CPU remote sense
 From CPU, for CPU remote sense
 Put PJP5000 & PJP5001 close to CPU

PC5028 & PC5029 for Transient Response

Close to Phase 1 Inductor

Net	Width	Net	Width
VR_VID0 - VR_VID6	10mil	DROOP & DROOP_FB	10mil
VR_ON & PSIF & RBIAS	10mil	VCC_PRR & VSUM	10mil
DPRSLPVR & DPRSTP#	10mil	ISEN1 & ISEN2	10mil
Vcore_PWRGD	10mil	Vcore_VDD & _VIN	25mil
MCH_PWOK	10mil	Vcore_BOOT1	25mil
VR_TT# & NTC	15mil	Vcore_BOOT2	25mil
Vcore_SS & _OCSET	15mil	Vcore_HG1 & _HG2	25mil
Vcore_FB & _COMP	15mil	Vcore_LG1 & _LG2	25mil
Vcore_VDIFF	15mil	Vcore_PHASE2	Shape
Vcore_VCCsense	10mil	Vcore_SUR1 & _SUR2	Shape
Vcore_VSSsense	10mil	AC_BAT_SYS	Shape

<Variant Name>
ASUS Title : POWER_VCORE
 ASUSTek Computer/ INC. Engineer:
 Size Project Name
 Custom Z84J
 Date: 11/31/2008 Sheet: 81 of 88
 Rev: 1.1

<< Kennedy_Zhang >>

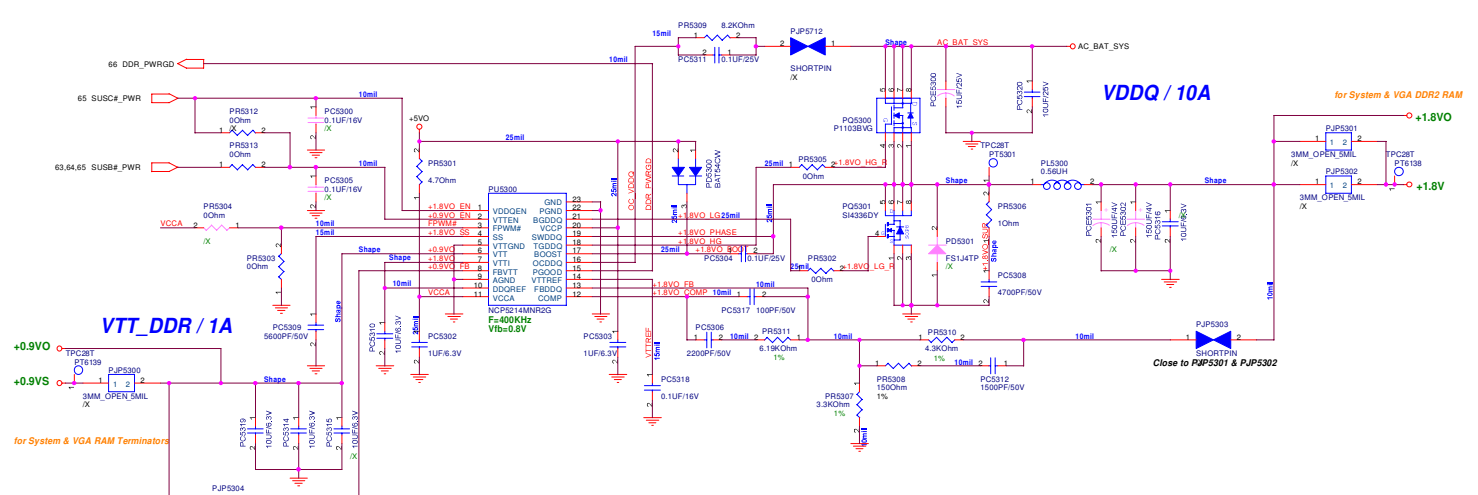

Net	Width	Net	Width
+1.8V0_EN	10mil	+1.8V0_BOOT	25mil
+1.8V0	Shape	+1.8V0_COMP	10mil
+0.9V0_EN	10mil	+1.8V0_HG_R	25mil
+0.9V0	Shape	+1.8V0_LG_R	25mil
+0.9V0_FB	10mil	+1.8V0_HG	25mil
+1.8V0 -> DDOREF	10mil	+1.8V0_LG	25mil
VTTREF	15mil	+1.8V0_PHASE	Shape
FPWM#	10mil	+1.8V0_SUR	Shape
VCCA	10mil	+1.8V0_FB	10mil
DDR_PWRGD	10mil	+1.8V0_SS	15mil
OC_VDDO	15mil	AC_BAT_SYS	Shape

ASUS Title: POWER_IO_DDR & VTT
 ASUSTek Computer INC. Engineer:
 Size Project Name Rev
 Custom Z84J 1.1
 Date: 08/11/2005 Sheet: 62 of 69

<< Kennedy_Zhang >>

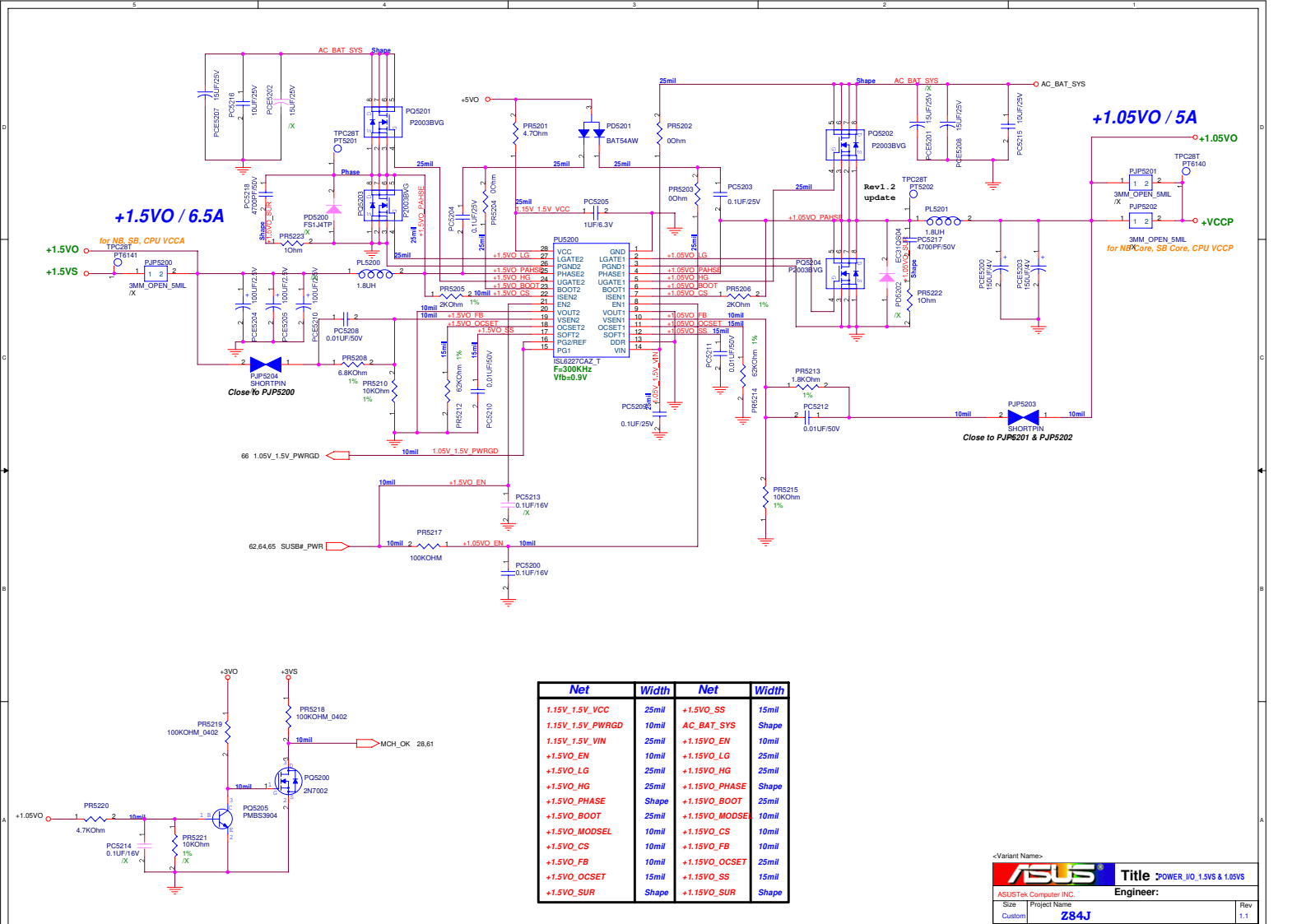

Net	Width	Net	Width
1.15V_1.5V_VCC	25mil	+1.5V_SS	15mil
1.15V_1.5V_PWRGD	10mil	AC_BAT_SYS	Shape
1.15V_1.5V_VIN	25mil	+1.5V_EN	10mil
+1.5V_VIN	10mil	+1.5V_LG	25mil
+1.5V_LG	25mil	+1.5V_HG	25mil
+1.5V_HG	25mil	+1.5V_PHASE	Shape
+1.5V_PHASE	Shape	+1.5V_BOOT	25mil
+1.5V_BOOT	25mil	+1.5V_MODSEL	10mil
+1.5V_MODSEL	10mil	+1.5V_CS	10mil
+1.5V_CS	10mil	+1.5V_FB	10mil
+1.5V_FB	10mil	+1.5V_OCSET	25mil
+1.5V_OCSET	15mil	+1.5V_SS	15mil
+1.5V_SUR	Shape	+1.5V_SUR	Shape

<Variant Name>

ASUS Title POWER_IO_1.5VS & 1.05VS

ASUSTek Computer INC. Engineer:

Size	Project Name	Rev
Custom	Z84J	1.1
Date: 11/30/2008	Sheet: 63 of 88	

<< Kennedy_Zhang >>

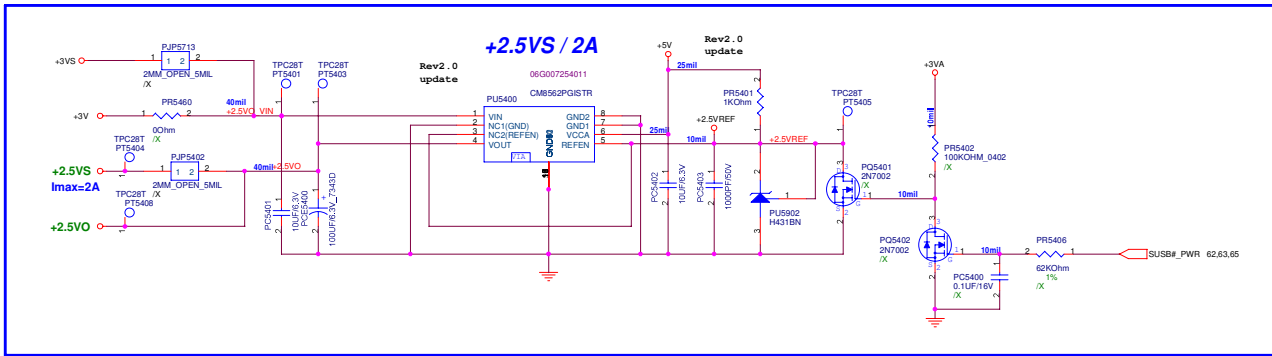
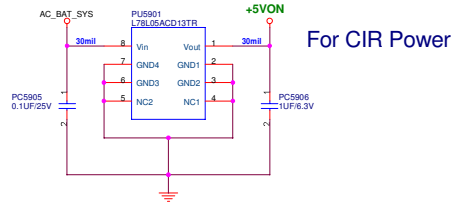
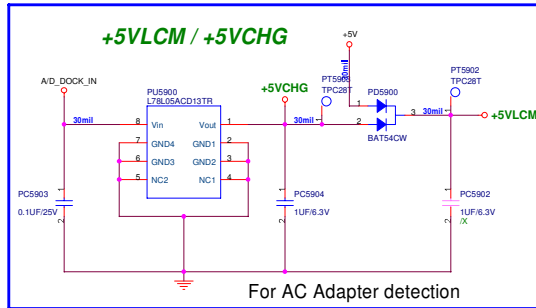
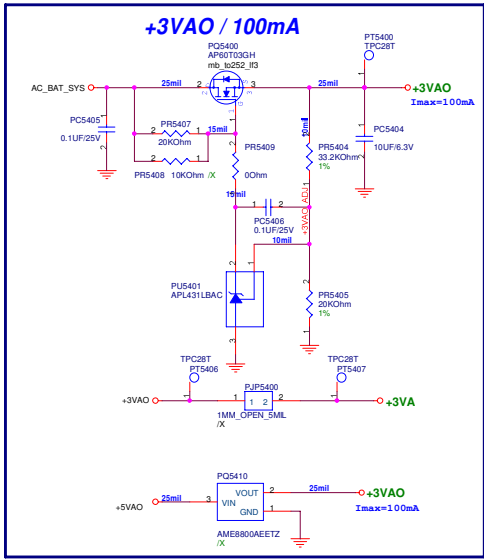

ASUS		Title : POWER_IO_+3VA & +2.5V	
ASUSTek Computer INC.		Engineer:	
Size	Project Name		Rev
Custom	Z84J		1.1
Date: 08/11/2006		Sheet: 04	of 09

<< Kennedy_Zhang >>

SUSB#_PWR POWER

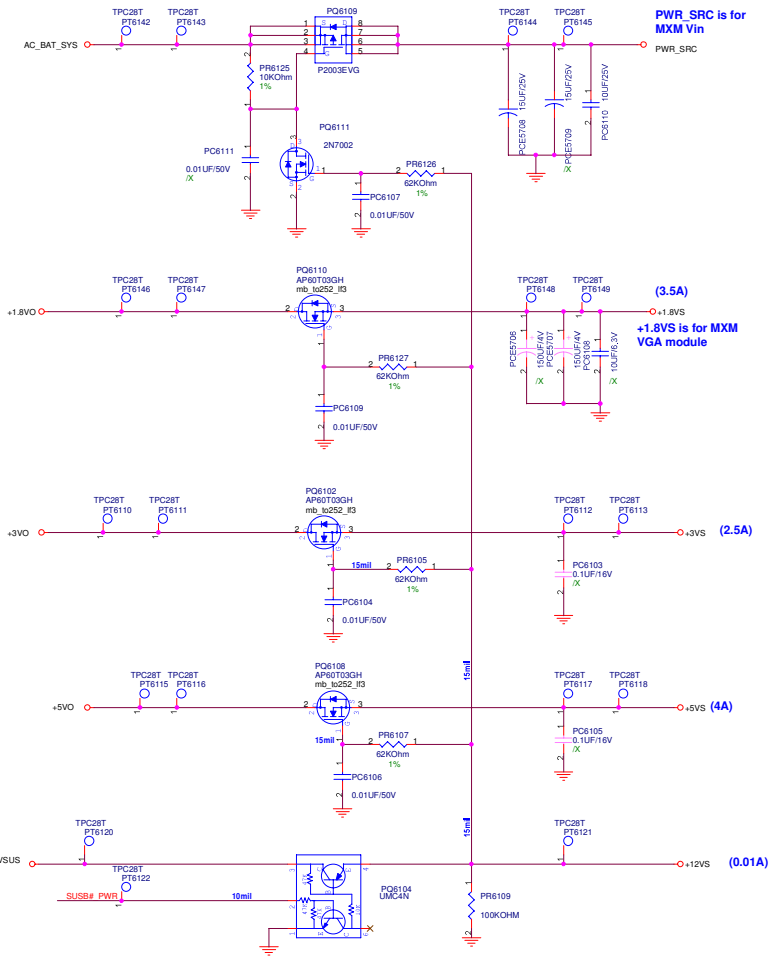

SUSC#_PWR POWER

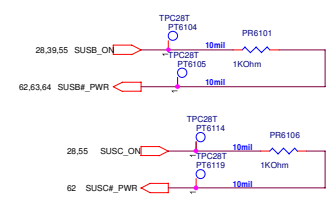
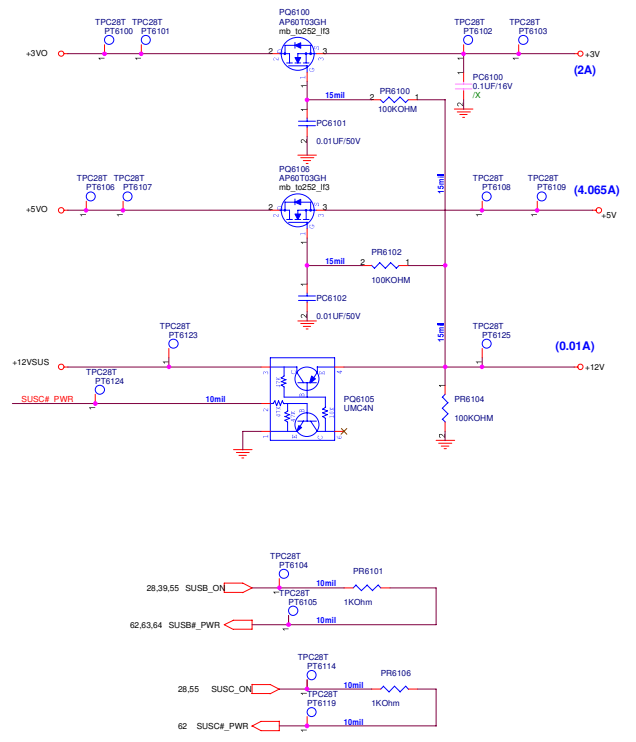

<Variant Name>

ASUS		Title : POWER_LOAD_SWITCH	
ASUSTek Computer INC.	Project Name	Engineer:	Rev
Custom	Z84J		1.1
Date: 2008-11-30	Sheet: 65	of 88	

<< Kennedy_Zhang >>

Power Good Detector

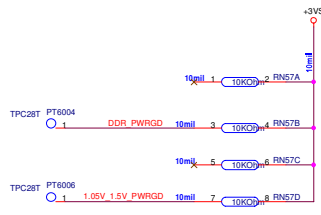
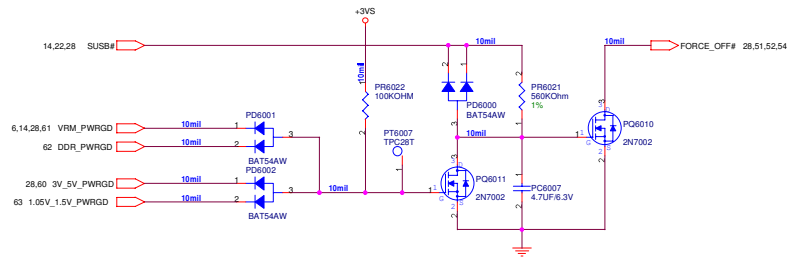

<Variant Name>

ASUS		Title : POWER_PROTECT	
ASUSTek Computer INC. Engineer :			
Size	Project Name		Rev
Custom	Z84J		1.1
Date: 11/31/2006		Sheet 66	of 88

<< Kennedy_Zhang >>

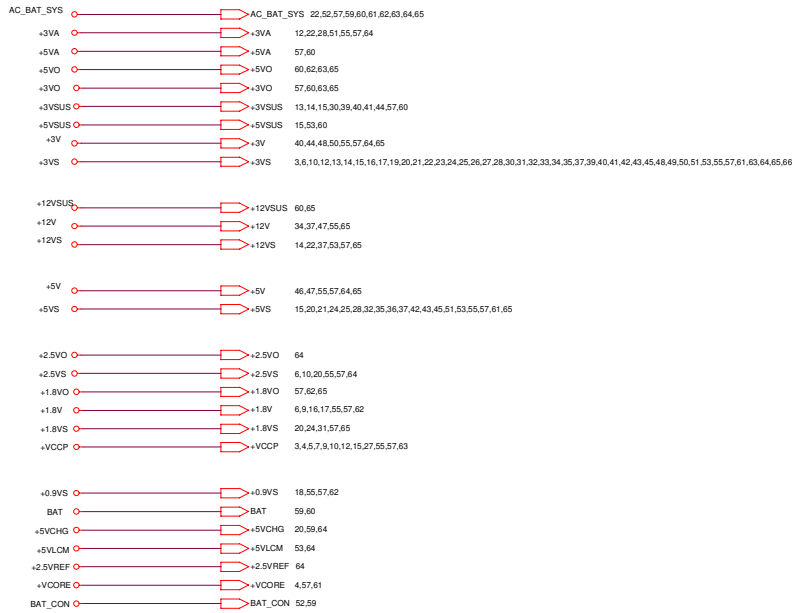

<Variant Name>

		Title : POWER_SIGNAL	
ASUSTek Computer INC.		Engineer: JEFF	
Size	Project Name		Rev
Custom	Z84J		1.1
Date: 11/31/2006		Sheet	67 of 88

<< Kennedy_Zhang >>

Rev	Date	Description
1.0	04/10/06	1. Initial release.(From Z84F)
1.1	08/08/06	1. Change Audio Codec from AD1988B to ALC888(Page 35) 2. Change AJ2, AJ3 to Azalia type 3. Correct RN2 Connection 4. Add PR5312, PR5313 to fix NANYA DIMM S3 fail issue(Page 62) 5. MXM_PWROK : remove R80(Page 19, Page 28) 6. PR5308 change to 1.2K 1% 0603(Page 62) 7. Change Inverter Connector type (12pin) & Pin define CON7(Page 22) 8. Remove : AR1, AR6, AR7, AR8, AR13, AR14, AR15, AR18, AR19, AR21, AR22, AR34, AC1, AC2, AC4, AC5, AC7, AC8, AC11, AC13, AC23, AC25, AC26, AC27, AU2, AQ6, AQ7, AQ9, AQ12 Add : AC81-AC85, AR71, ARN3, AD3, AD4, AL16
	08/10/06	1. Remove T100-T118(Page 41) 2. Add PU5901, PC5905, PC5906 for CIR Power(Page 64) 3. PR5308 change to 150K 1% 0603, PC5312 change to 1500PF 0603(Page 62) 4. Add PR5060, PR5061(Page 61) 5. PR5114 change to 27K 1% 0603(Page 60) 6. PR5722 change to 22K 1% 0603, Stuff PR5721(Page 59) 7. R77 change to 4.7K, Pull to +5VCHG for AC_OK(Page 20) 8. Change connection of L23, L24 9. Change CON18 P/N 10. Add D30, D31, D32, C175, C176, R136(Page 28)
	08/11/06	1. Add Audio Amp. AU100, AR100-AR103, AC100-AC107, non-stuff AC41(Page 36) 2. AC82 change to 1uF 0603, Add AU2, AC23, AC86, AC87, AR72, AR73, AJP1, AJP2, Remove AC12 3. Change MXM SMBus connection to EC, SMB1_CLK, SMB1_DAT(Page 28, Page19)
1.2	08/29/06	1. Change eSATA Controller from SiB531 to JMB360(Page 31)

Rev	Date	Description

<Variant Name>		ASUS Title : History	
ASUSTek Computer INC.		Engineer: Jack Hsu	
Size	Project Name		Rev
Custom	Z84J		1.1
Date: 08/10/2006		Sheet	68 of 68

<< Kennedy_Zhang >>