

RTC BTY
BATT

PART for BOM only

Function	ASUS Partnumber	LOCATION
RTC BTY	07G016412032	
GPU NB8M	02G190012900	

Temp Modify
1012: Delete EC23,31,32,34,39 already have in location
Delete EC35,36 No space to add
Delete GC114,115,120,121,122,123,116,117,118,119 No space to add

Z375_12

Title		Revision	
Size	Document Number	Rev	
A3	STD	2.0G	
Date	日期	Sheet	1 of 60

<< Kennedy_Zhang >>

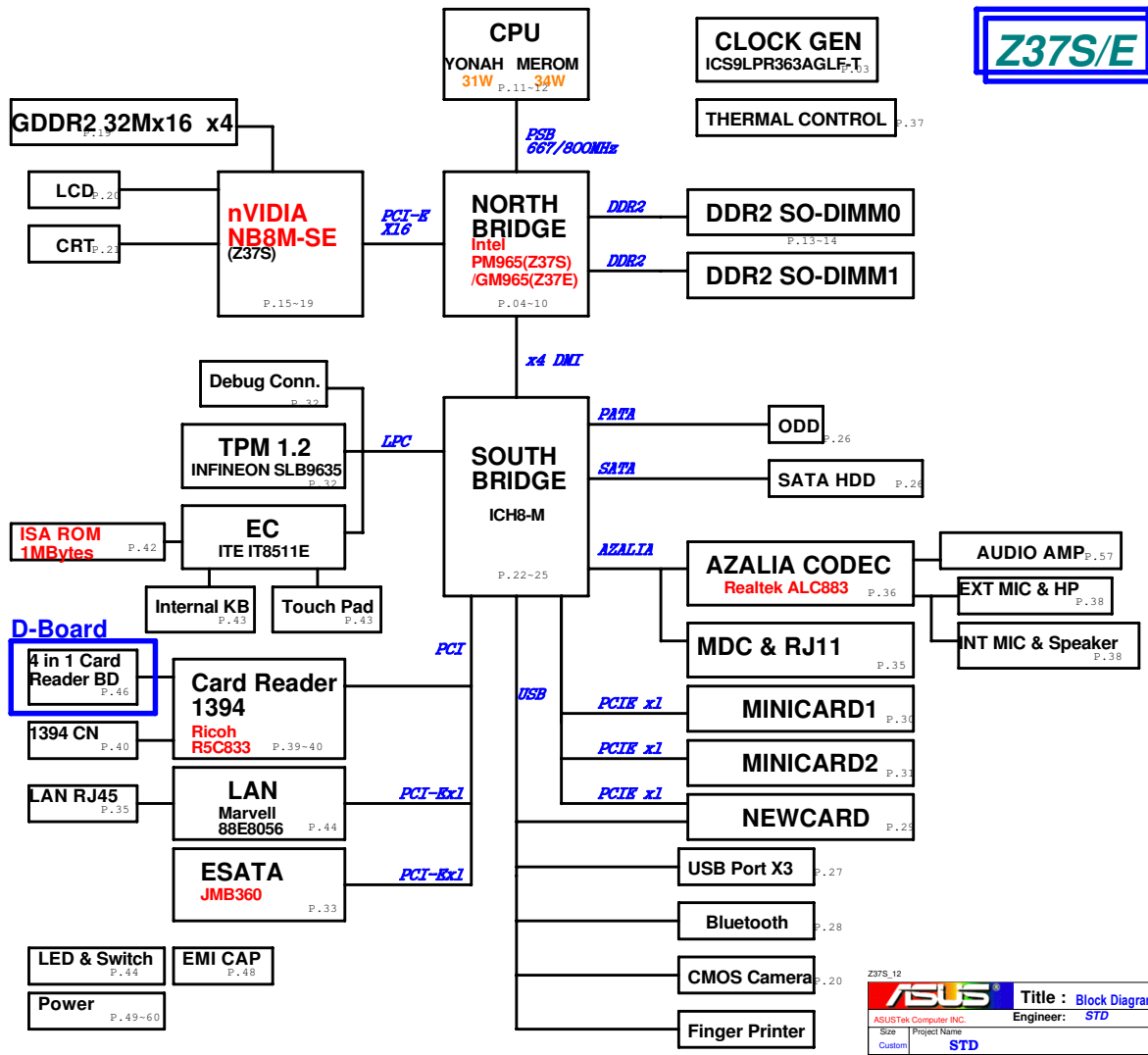

ASUS		Title : Block Diagram	
ASUSTek Computer INC.		Engineer: STD	
Size	Project Name	Rev	
Custom	STD	2.00	
Date: 11/01/08 2007		Sheet	2 of 80

<< Kennedy_Zhang >>

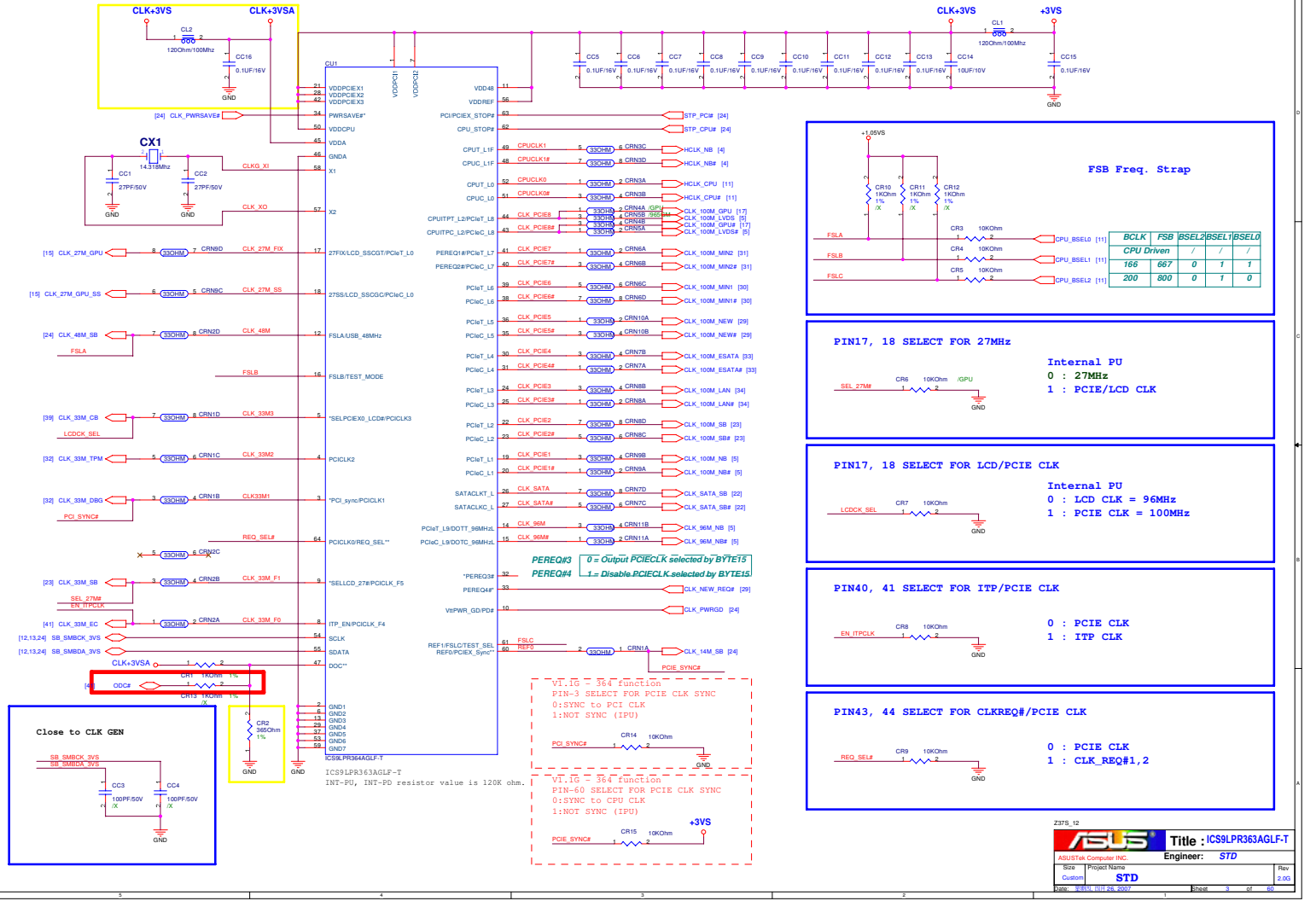

<< Kennedy_Zhang >>

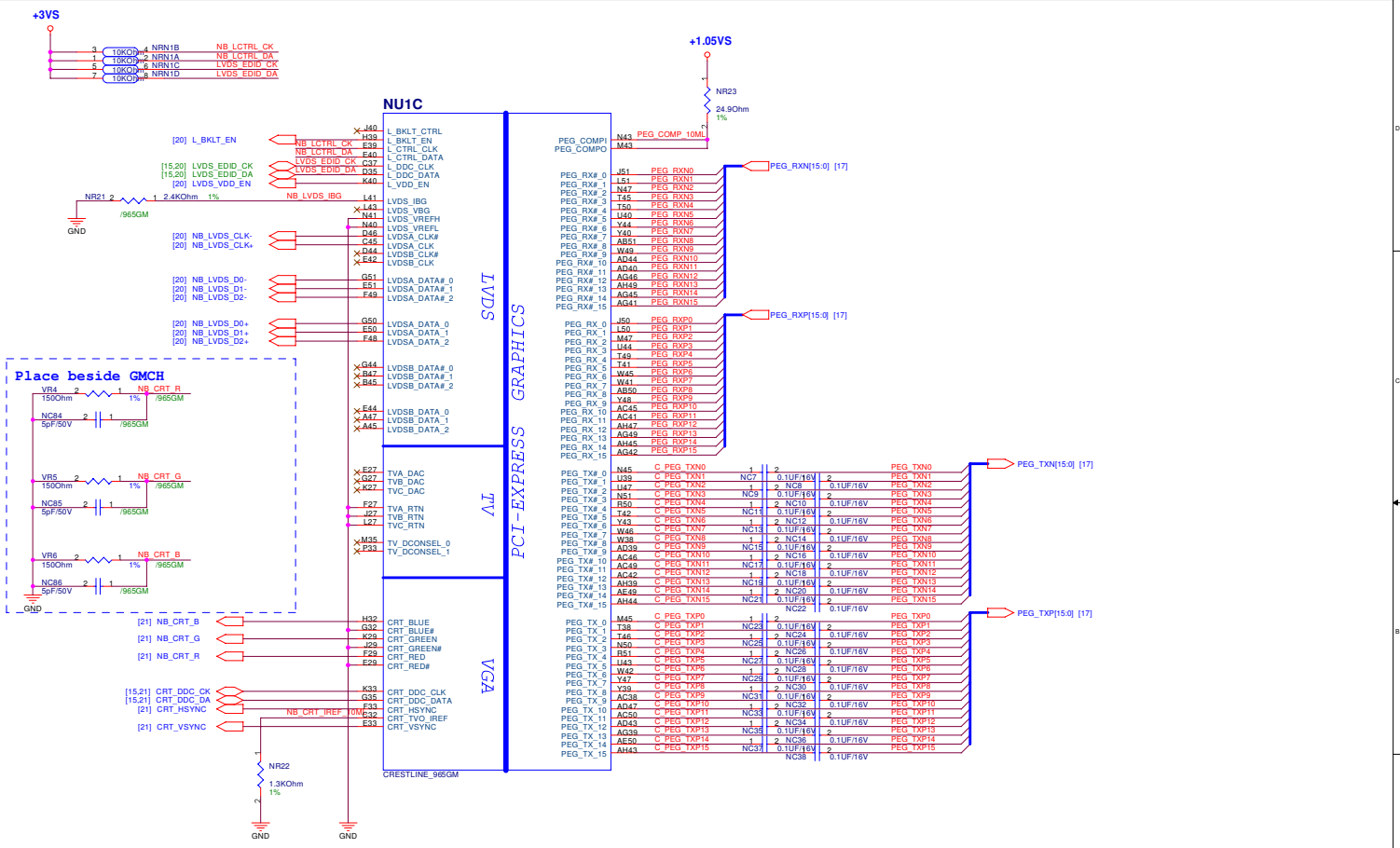

Z37S_12

Title NB-965GM3-PEG/VGA
Engineer: STD

ASUSTek Computer INC.	Rev
Site	Project Name
A3	STD
Date: 11/26/2007	Sheet: 6 of 80

<< Kennedy_Zhang >>

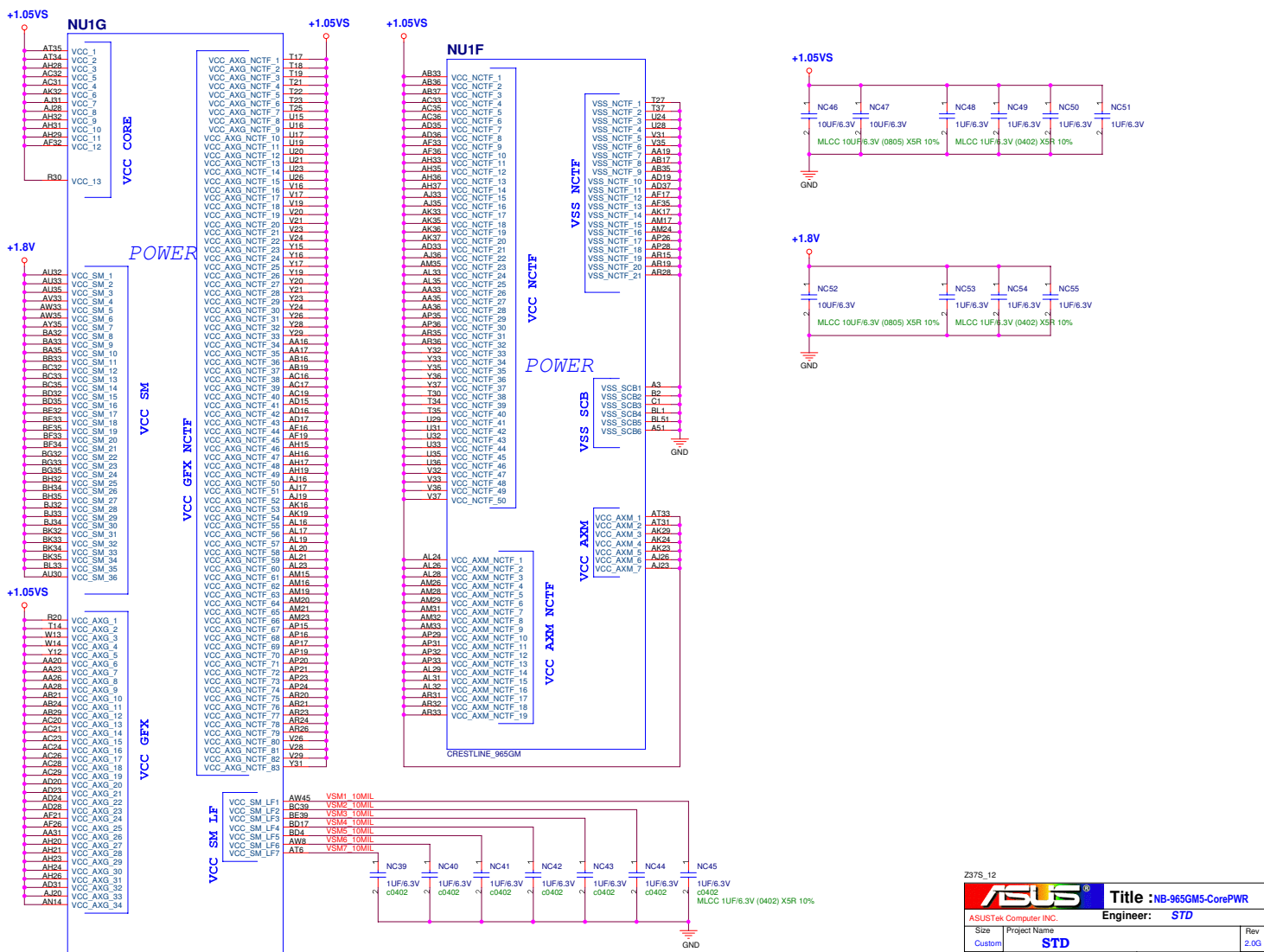

Z37S_12		ASUS Title : NB-965GM5-CorePWR	
ASUSTek Computer INC.		Engineer: STD	
Size	Project Name	Rev	
Custom	STD	2.00	
Date: 2007.07.26	Sheet	8	of 60

<< Kennedy_Zhang >>

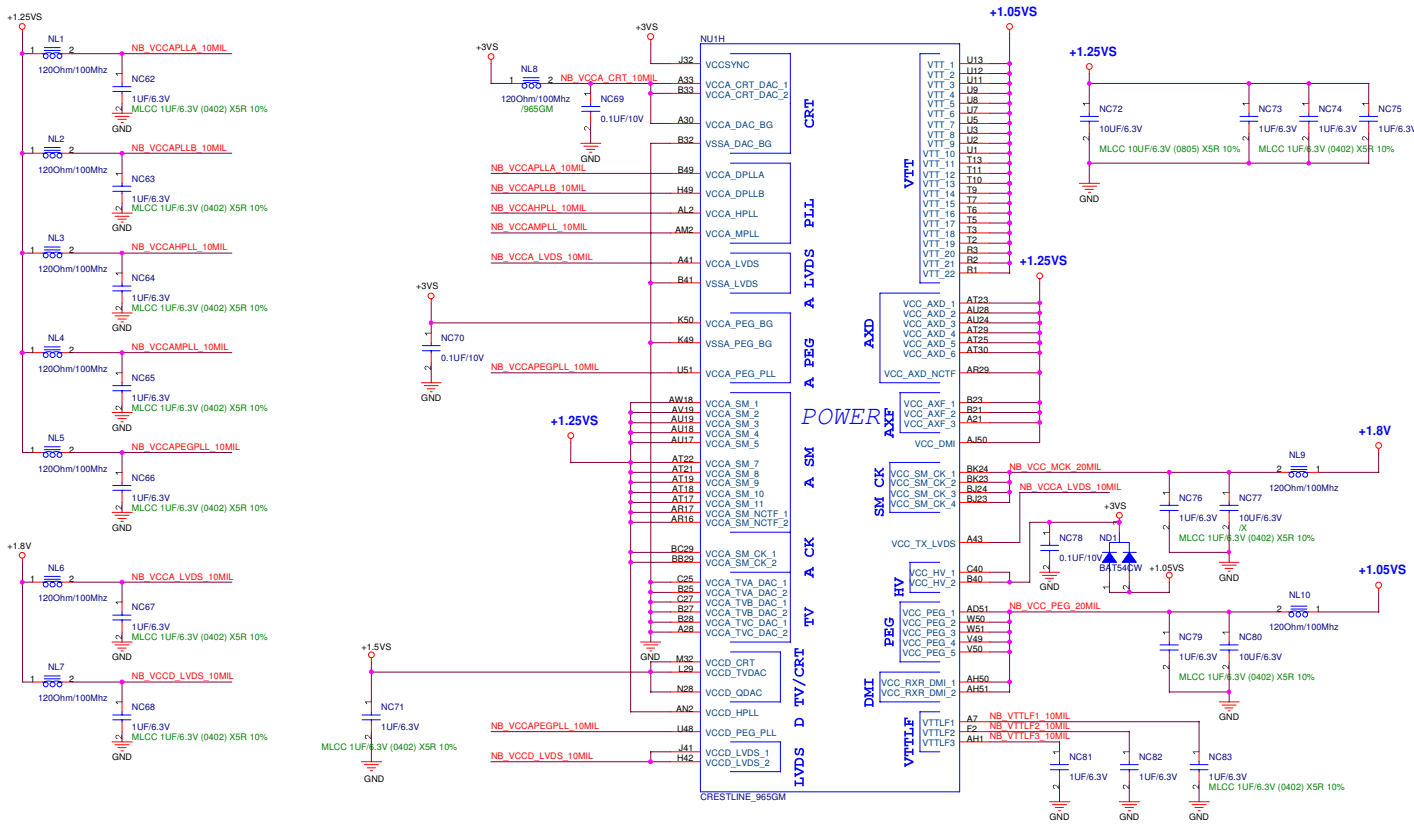

Z37S 12

ASUS		Title : NB-965GM6-IOPWR
ASUSTek Computer INC.		Engineer : STD
Size	Project Name	Rev
Custom	STD	2.0G
Date: 2007.10.26	Sheet: 9	of: 80

« Kennedy_Zhang »
 HIGH - LANES REVERSED

NU1I

A13	VSS_1	VSS_100	AW24
A15	VSS_2	VSS_101	AW29
A17	VSS_3	VSS_102	AW29
A24	VSS_4	VSS_103	AW5
AA21	VSS_5	VSS_104	AW7
AA22	VSS_6	VSS_104	AV10
AA23	VSS_7	VSS_106	AV24
AB20	VSS_8	VSS_107	AV27
AB23	VSS_9	VSS_108	AV42
AB26	VSS_10	VSS_109	AV43
AB28	VSS_11	VSS_110	AV45
AB31	VSS_12	VSS_110	AV47
AC10	VSS_13	VSS_111	AV51
AC13	VSS_14	VSS_112	B10
AC3	VSS_15	VSS_114	B20
AC39	VSS_16	VSS_115	B24
AC43	VSS_17	VSS_116	B29
AC47	VSS_18	VSS_117	B30
AD1	VSS_19	VSS_118	B35
AD21	VSS_20	VSS_119	B38
AD26	VSS_21	VSS_120	B43
AD29	VSS_22	VSS_120	B46
AD3	VSS_23	VSS_121	B6
AD31	VSS_24	VSS_122	B6
AD45	VSS_25	VSS_123	B6
AD49	VSS_26	VSS_124	BA1
AD5	VSS_27	VSS_125	BA17
AD50	VSS_28	VSS_126	BA18
AD6	VSS_29	VSS_127	BA2
AE10	VSS_30	VSS_128	BA21
AE14	VSS_31	VSS_129	BB12
AE6	VSS_32	VSS_130	BB25
AF20	VSS_33	VSS_131	BB40
AF24	VSS_34	VSS_131	BB44
AF24	VSS_35	VSS_132	BB49
AF31	VSS_36	VSS_133	BB8
AG2	VSS_37	VSS_135	BC16
AG38	VSS_38	VSS_136	BC24
AG43	VSS_39	VSS_137	BC25
AG47	VSS_40	VSS_138	BC36
AG50	VSS_41	VSS_139	BC40
AH3	VSS_42	VSS_140	BC51
AH40	VSS_43	VSS_141	BD13
AH41	VSS_44	VSS_142	BD2
AH7	VSS_45	VSS_143	BD28
AH9	VSS_46	VSS_144	BD45
AH9	VSS_47	VSS_144	BD5
AH11	VSS_48	VSS_146	BE1
AH24	VSS_49	VSS_148	BE19
AH25	VSS_50	VSS_149	BE23
AH29	VSS_51	VSS_149	BE30
AH32	VSS_52	VSS_151	BE42
AH3	VSS_53	VSS_152	BE51
AH4	VSS_54	VSS_153	BE8
AH9	VSS_55	VSS_154	BE12
AK20	VSS_56	VSS_155	BF16
AK21	VSS_57	VSS_156	BF36
AK26	VSS_58	VSS_157	BG19
AK28	VSS_59	VSS_157	BG2
AK31	VSS_60	VSS_159	BG24
AK51	VSS_61	VSS_160	BG29
AL1	VSS_62	VSS_161	BG39
AM11	VSS_63	VSS_162	BG48
AM13	VSS_64	VSS_163	BG5
AM4	VSS_65	VSS_164	BG51
AM41	VSS_66	VSS_165	BH17
AM45	VSS_67	VSS_166	BH30
AM45	VSS_68	VSS_167	BH44
AN1	VSS_69	VSS_168	BH46
AN38	VSS_70	VSS_169	BH8
AN39	VSS_71	VSS_170	BI11
AN43	VSS_72	VSS_171	BI13
AN5	VSS_73	VSS_172	BJ38
AN7	VSS_74	VSS_173	BJ4
AP4	VSS_75	VSS_174	BJ42
AP48	VSS_76	VSS_175	BJ46
AR10	VSS_77	VSS_176	BK15
AR11	VSS_78	VSS_177	BK17
AR2	VSS_79	VSS_178	BK25
AR39	VSS_80	VSS_179	BK29
AR44	VSS_81	VSS_180	BK36
AR7	VSS_82	VSS_181	BK40
AR7	VSS_83	VSS_181	BK44
AT10	VSS_84	VSS_182	BK6
AT14	VSS_85	VSS_183	BK6
AT41	VSS_86	VSS_184	BK9
AT58	VSS_87	VSS_184	BL11
AL1	VSS_88	VSS_185	BL13
AU23	VSS_89	VSS_186	BL19
AU29	VSS_90	VSS_187	BL22
AU3	VSS_91	VSS_188	BL37
AU36	VSS_92	VSS_189	BL47
AU49	VSS_93	VSS_190	C12
AU51	VSS_94	VSS_191	C19
AU58	VSS_95	VSS_192	C19
AV48	VSS_96	VSS_193	C19
AW1	VSS_97	VSS_194	C29
AW12	VSS_98	VSS_195	C39
AW16	VSS_99	VSS_196	C33
		VSS_197	C36
		VSS_198	C41

CRESTLINE_965GM

GND

NU1J

C46	VSS_199	VSS_287	W11
C50	VSS_200	VSS_288	W39
C7	VSS_201	VSS_289	W43
D13	VSS_202	VSS_290	W47
D24	VSS_203	VSS_291	W5
D3	VSS_204	VSS_292	W7
D32	VSS_205	VSS_293	Y13
D39	VSS_206	VSS_294	Y2
D45	VSS_207	VSS_295	Y41
D49	VSS_208	VSS_296	Y49
E10	VSS_209	VSS_297	Y5
E16	VSS_210	VSS_298	Y50
E24	VSS_211	VSS_299	Y5
E26	VSS_212	VSS_300	P29
E32	VSS_213	VSS_301	T11
E47	VSS_214	VSS_302	T29
F19	VSS_215	VSS_303	T31
F36	VSS_216	VSS_304	T33
F4	VSS_217	VSS_305	R28
F40	VSS_218		
F50	VSS_219		
G1	VSS_220		
G13	VSS_221	VSS_306	AA32
G16	VSS_222	VSS_307	AB35
G19	VSS_223	VSS_308	AD32
G24	VSS_224	VSS_309	AF29
G28	VSS_225	VSS_310	AF29
G29	VSS_226	VSS_311	AI21
G33	VSS_227	VSS_312	AV25
G42	VSS_228	VSS_313	HS0
G45	VSS_229		
G48	VSS_230		
G8	VSS_231		
H24	VSS_232		
H28	VSS_233		
H4	VSS_234		
H45	VSS_235		
H11	VSS_236		
H16	VSS_237		
H2	VSS_238		
H28	VSS_239		
H33	VSS_240		
H35	VSS_241		
H39	VSS_242		
H39	VSS_243		
K12	VSS_245		
K47	VSS_246		
K6	VSS_247		
L1	VSS_248		
L17	VSS_249		
L20	VSS_250		
L24	VSS_251		
L28	VSS_252		
L3	VSS_253		
L33	VSS_254		
L49	VSS_255		
M28	VSS_256		
M42	VSS_257		
M46	VSS_258		
M49	VSS_259		
M5	VSS_260		
M50	VSS_261		
M9	VSS_262		
N11	VSS_263		
N14	VSS_264		
N17	VSS_265		
N29	VSS_266		
N32	VSS_267		
N38	VSS_268		
N39	VSS_269		
N44	VSS_270		
N45	VSS_271		
N7	VSS_272		
P19	VSS_273		
P2	VSS_274		
P23	VSS_275		
P3	VSS_276		
P50	VSS_277		
P48	VSS_278		
T39	VSS_279		
T43	VSS_280		
T47	VSS_281		
U41	VSS_282		
U45	VSS_283		
U50	VSS_284		
V2	VSS_285		
V3	VSS_286		

CRESTLINE_965GM

GND

VSS

VSS

Z37S_12

ASUS Title : NB-965GM7-GND

ASUSTek Computer INC. Engineer: STD

Size	Project Name	Rev
Custom	STD	2.0G

Date: 10/11/26/2007 Sheet 10 of 80

<< Kennedy_Zhang >>

VCORE

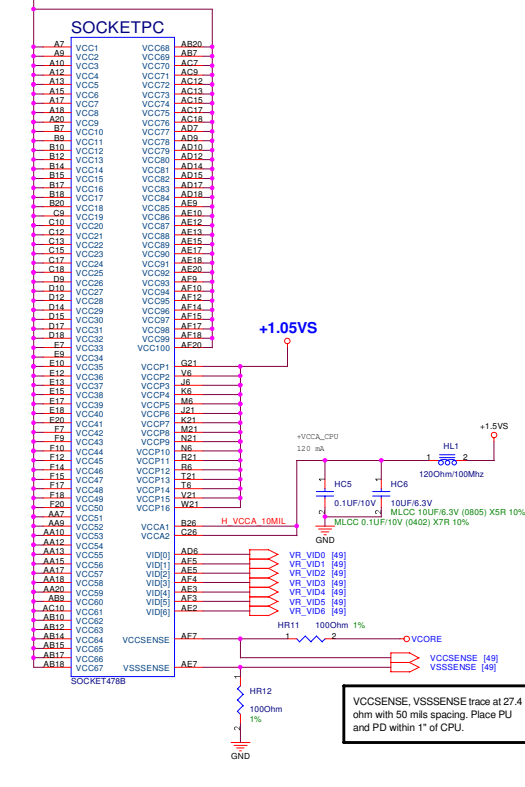

SOCKETPD

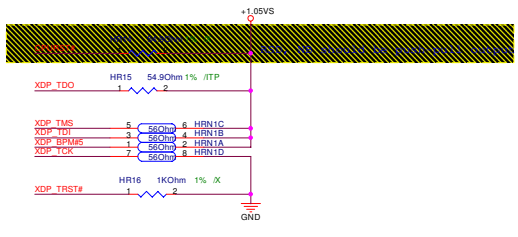
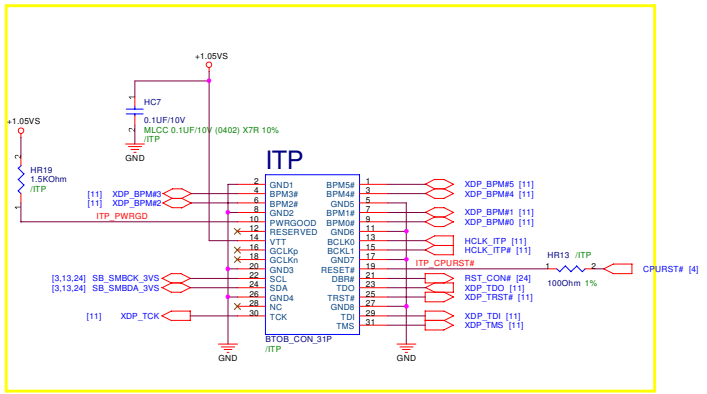
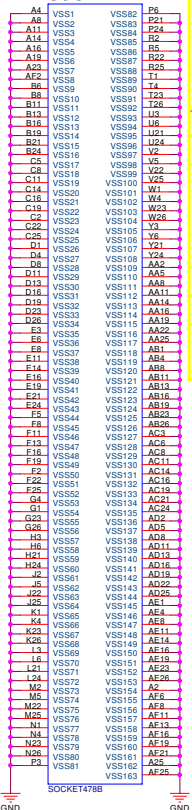

<< Kennedy_Zhang >>

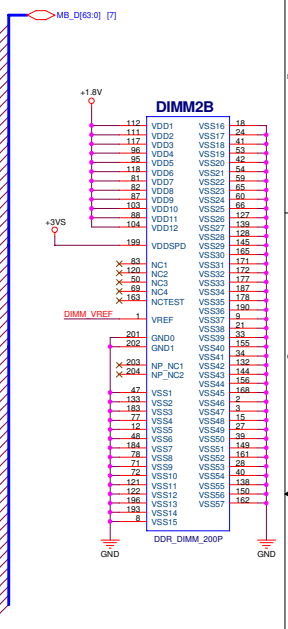
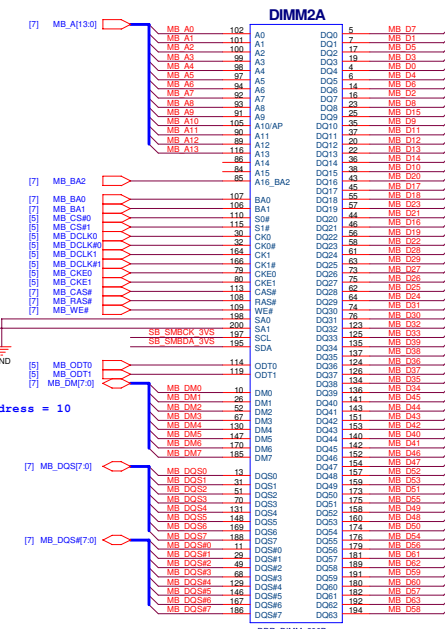
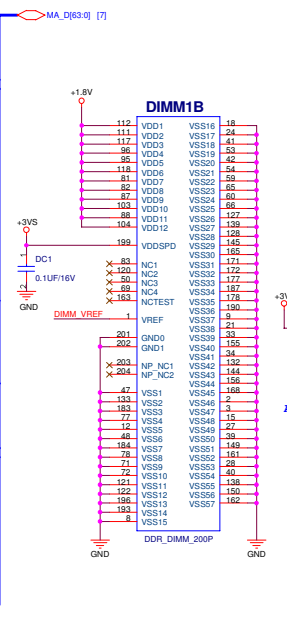
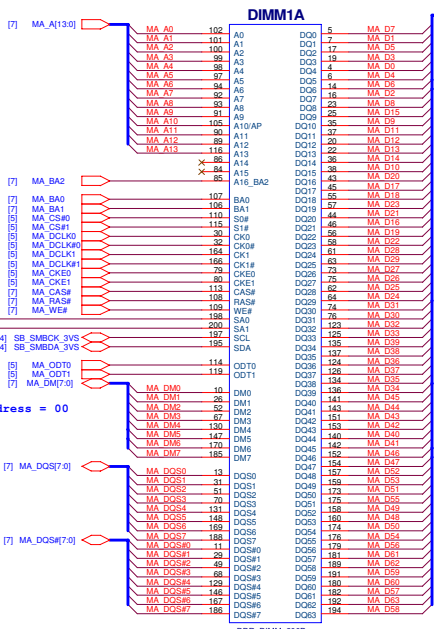

DDR_DIMM_200P
12G025122007

DDR_DIMM_200P
12G025C22000

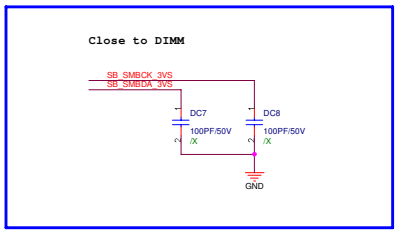
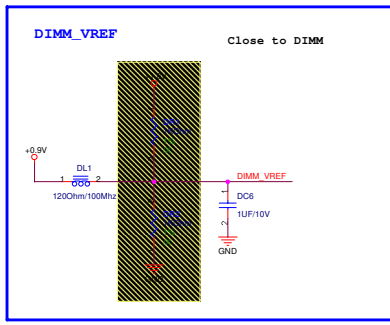
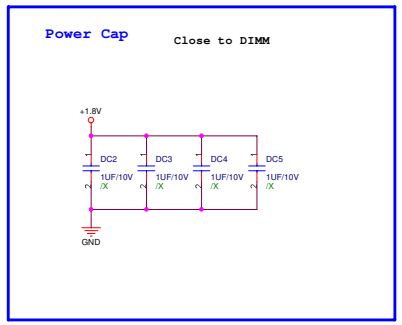

<< Kennedy_Zhang >>

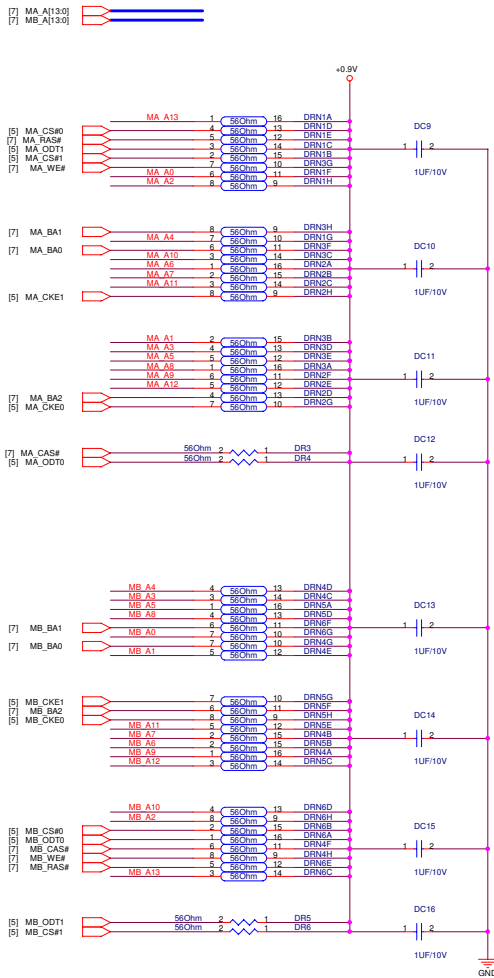

Z37S_12

ASUS		Title : DDR2 TERMINATION	
ASUSTek Computer INC.		Engineer: STD	
Size	Project Name		Rev
Custom	STD		2.00
Date: 11/04/2007		Sheet 14	of 80

<< Kennedy_Zhang >>

**GPU NB8M :
02G190012910
V2.0G**

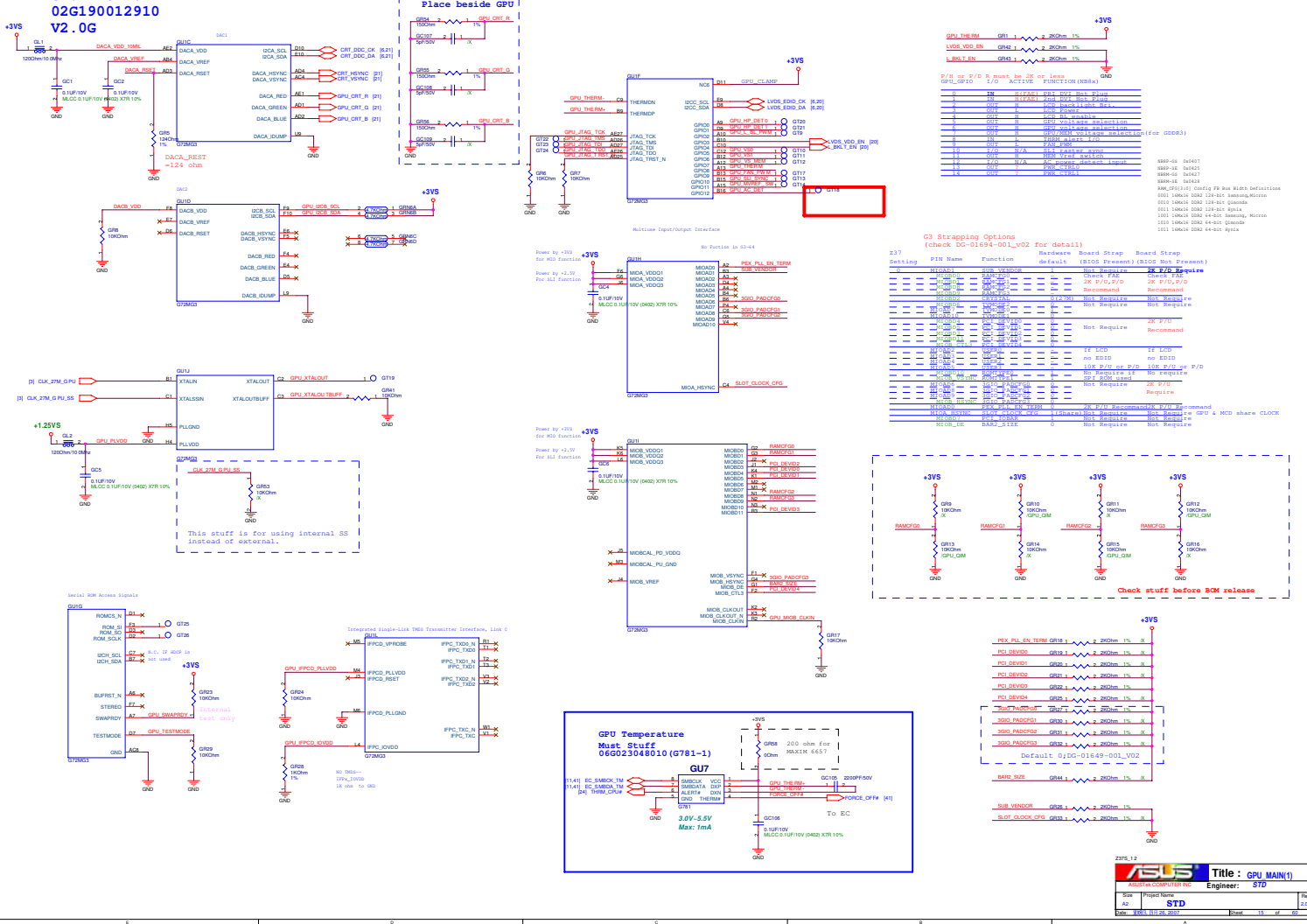

<< Kennedy_Zhang >>

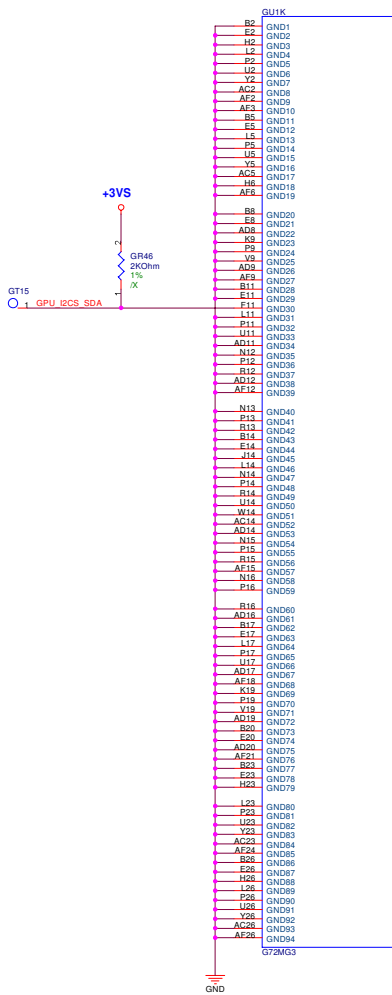

- B2 GND1
- E2 GND2
- L2 GND3
- P2 GND4
- U2 GND5
- Y2 GND6
- AF2 GND7
- AF2 GND8
- AF2 GND9
- AF2 GND10
- BS GND11
- BS GND12
- LS GND13
- PS GND14
- US GND15
- YS GND16
- AC2 GND17
- H2 GND18
- AF2 GND19
- BB GND20
- ES GND21
- AD2 GND22
- K2 GND23
- P2 GND24
- V2 GND25
- AD2 GND26
- AF2 GND27
- B11 GND28
- F11 GND29
- F11 GND30
- L11 GND31
- P11 GND32
- U11 GND33
- AD11 GND34
- N12 GND35
- P12 GND36
- AD12 GND37
- AF12 GND38
- N13 GND39
- P13 GND40
- R13 GND41
- B14 GND42
- E14 GND43
- L14 GND44
- N14 GND45
- U14 GND46
- P14 GND47
- R14 GND48
- U14 GND49
- W14 GND50
- AC14 GND51
- AD14 GND52
- N15 GND53
- P15 GND54
- B15 GND55
- AF15 GND56
- N16 GND57
- P16 GND58
- R16 GND59
- AD16 GND60
- B17 GND61
- F17 GND62
- L17 GND63
- P17 GND64
- U17 GND65
- AD17 GND66
- AF18 GND67
- K19 GND68
- P19 GND69
- V19 GND70
- AD19 GND71
- E20 GND72
- E20 GND73
- E20 GND74
- AD20 GND75
- AF21 GND76
- E22 GND77
- H23 GND78
- H23 GND79
- L23 GND80
- P23 GND81
- Y23 GND82
- AC23 GND83
- AF24 GND84
- E24 GND85
- ES24 GND86
- E24 GND87
- H24 GND88
- L24 GND89
- P24 GND90
- U24 GND91
- Y24 GND92
- AC24 GND93
- AF24 GND94

Z37S_12

ASUS Title : GPU_POWER_GND(4)

ASUSTEK COMPUTER INC. Engineer: STD

Size	Project Name	Rev
A3	STD	2.0G
Date: 11/26/2007	Sheet 18 of 90	

<< Kennedy_Zhang >>

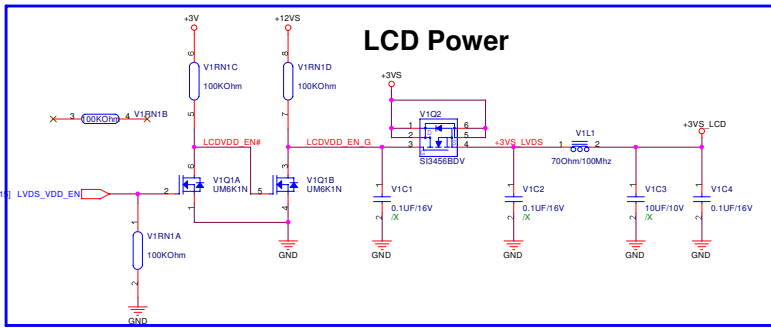

LCD LVDS Connector

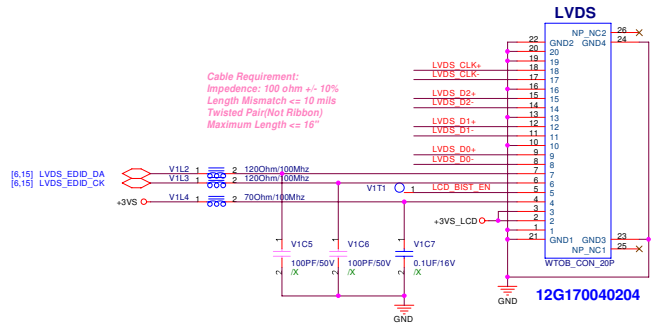

LVDS from 965GM

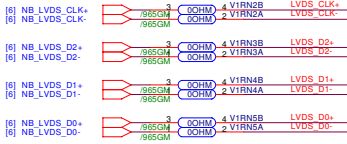

LVDS from GPU-NB8M

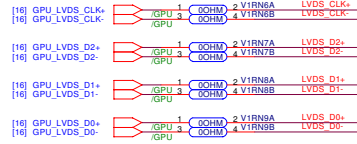

LCD Inverter Connector

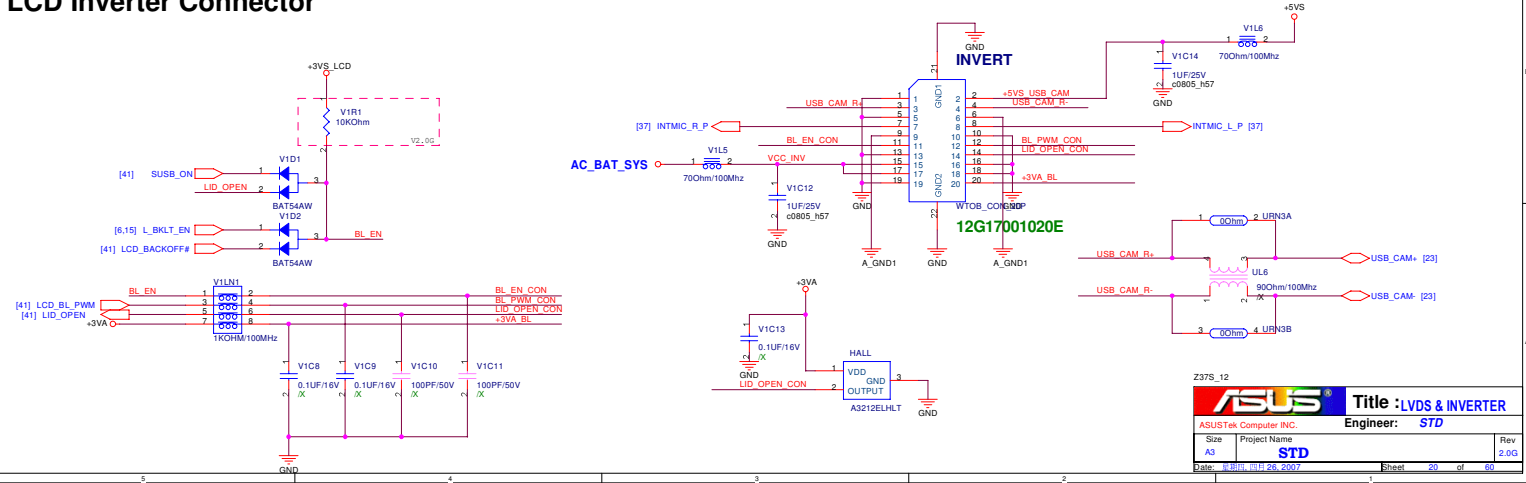

ASUS		Title :LVDS & INVERTER	
ASUSTek Computer INC.		Engineer: STD	
Size	Project Name	Rev	
A3	STD	2.0G	
Date: 11/28/2007	Sheet	26	of 60

<< Kennedy_Zhang >>

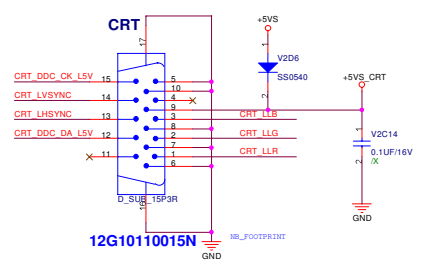
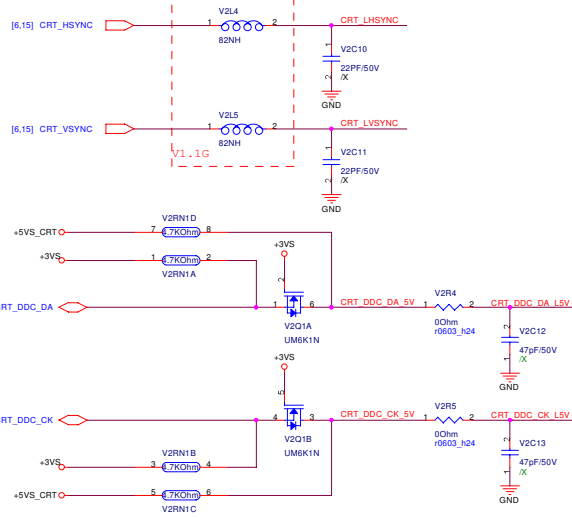
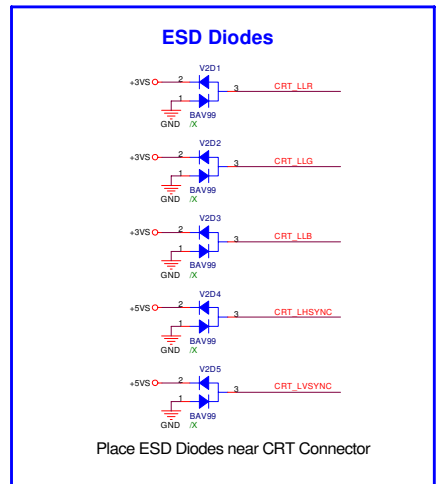
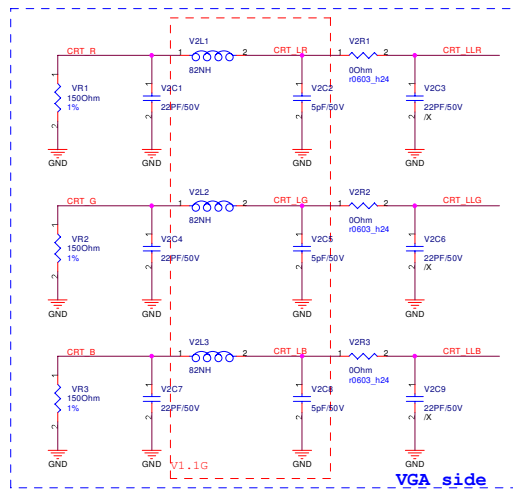
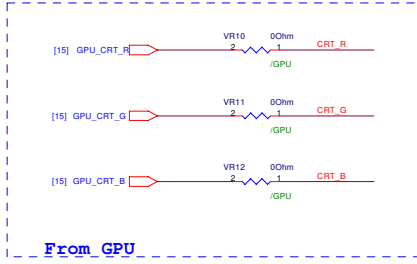
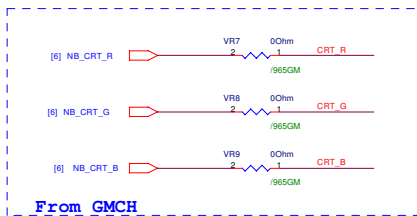

ASUS		Title : CRT
ASUSTek Computer Inc.		Engineer: STD
Size	A3	Project Name
Date	11/28/2007	Rev
		2.0G
		Sheet 21 of 60

<< Kennedy_Zhang >>

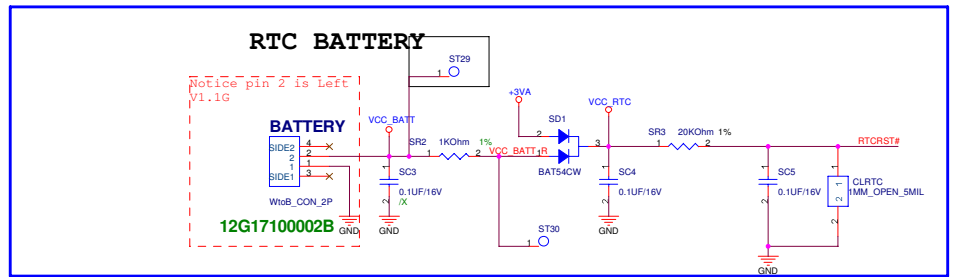
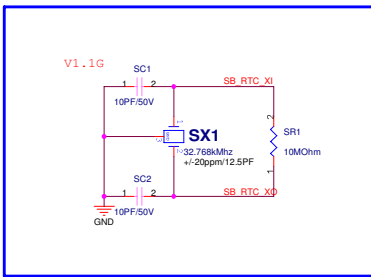

S. B.
02G010017400
V2.0G

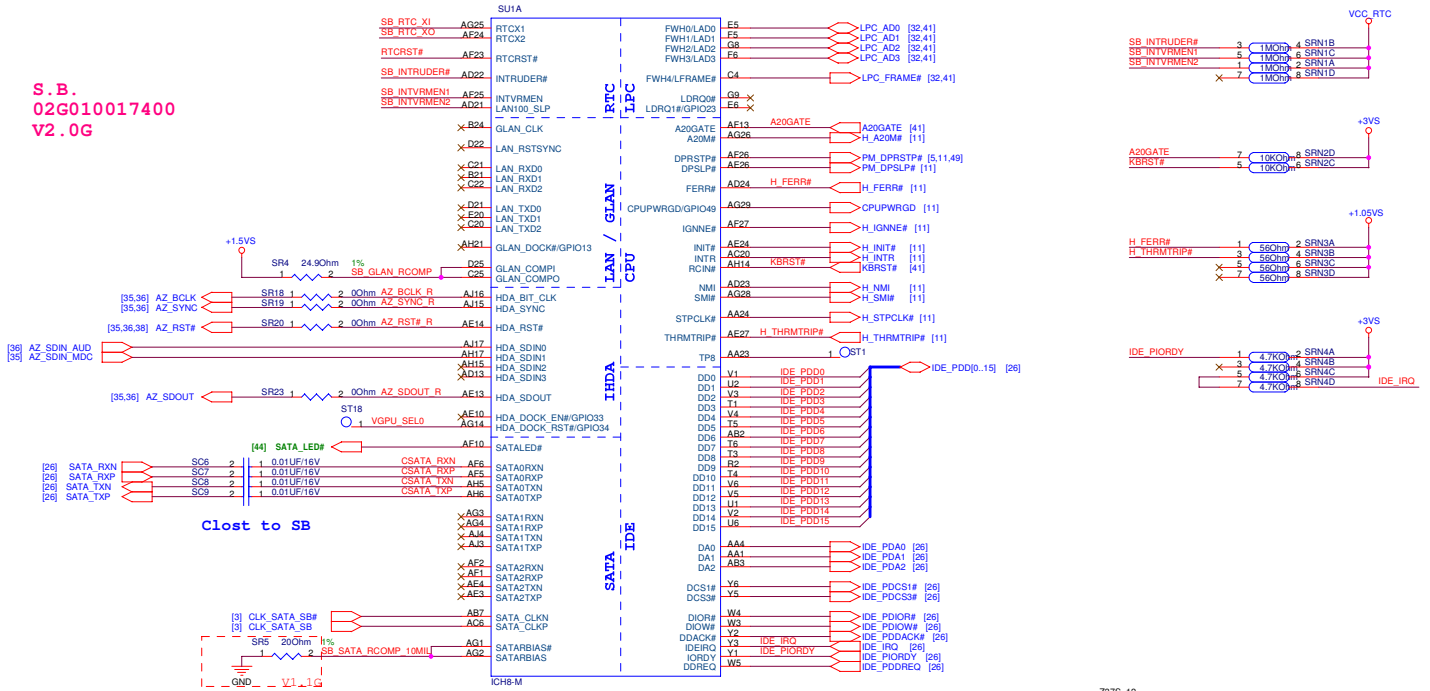

Z375_12

ASUS		Title : ICH8-M (1)	
ASUSTek Computer INC.		Engineer: STD	
Size	Project Name		Rev
Custom	STD		2.2G
Date: 2007.07.26		Sheet 22	of 60

<< Kennedy_Zhang >>

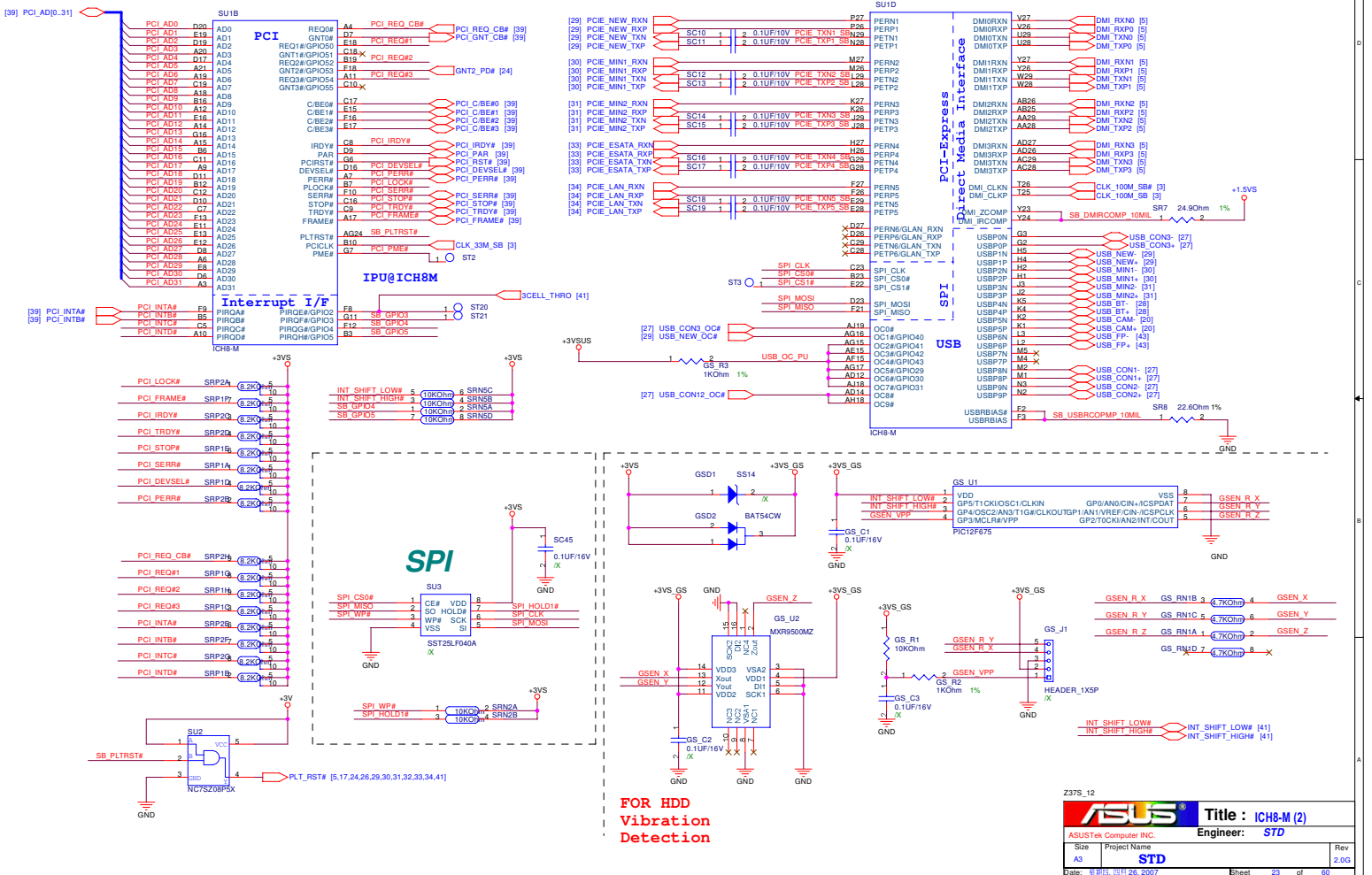

**FOR HDD
Vibration
Detection**

Z37S_12		ASUS		Title : ICH8-M (2)	
ASUSTek Computer Inc. Engineer: STD					
Size	Project Name		Rev		
A3	STD		2.0G		
Date: 11/12/26/2007	Sheet		23 of 30		

<< Kennedy_Zhang >>

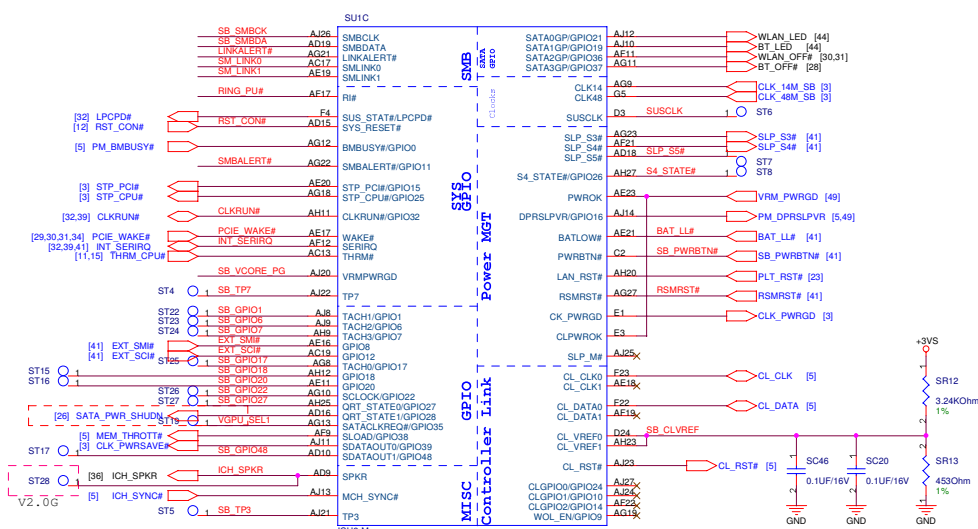

(ICH_TP3)
 1 = PCIE Strap (*) default internal PU
 0 = XOR chan test mode
 (HDA_SDOUT, HDA_SYNC)
 (11) = LANE1-4 as a PCIe4 port
 (00) = LANE1-4 as 4 PCIe1 ports (*) default internal PD
 others = reserved
 (GNT2#)
 1 = LANES-6 reserved (internal PU)
 0 = LANES-6 as 2 PCIe1 ports (*)
 (GNT2_PD#)
 SR14 1KOhm 1%
 (SB_GPIO20)
 1 = reserved
 0 = Intel recommend (* internal PD)
 (GNT1#)
 1 = Destop/Mobile (* internal PU)
 0 = Server
 (GNT3#)
 1 = Normal (* internal PU)
 0 = Top-block swap for FW
 (SPI_CS1# : GNT0#) = 11 (* internal PU)

GNT0#	SPI_CS1#
SPI	0
PCI	1
LPC	1

(INTVRMEN, LAN100_SLP)
 1 = Enabled internal VRMs for VccSusi_05, 1_5 and VccCL1_5, 1_05 and VccLAN1_05 (*)
 0 = Disabled internal VRMs
 (ICH_SATALED#)
 1 = LANE1-4 normal (* internal PU)
 0 = LANE1-4 reverse
 (SPKR)
 1 = Disabled TCO Reboot
 0 = Enabled TCO Reboot (* internal PD)
 (TP_GPIO33) : Not used for ICH8M
 1 = Enabled Descriptor Security (* internal PU)
 0 = Disabled Descriptor Security

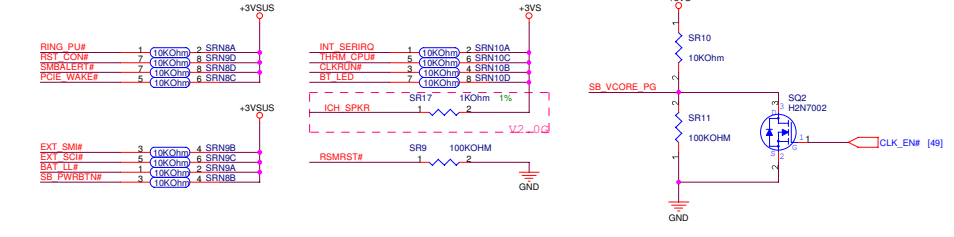
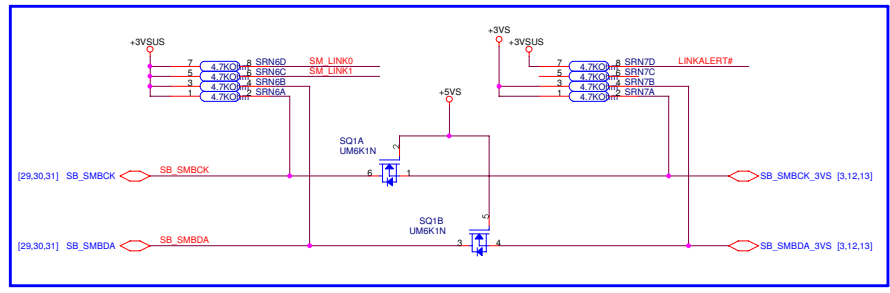

237S_12

ASUS Title: ICH8-M (3)

ASUSTek Computer INC. Engineer: STD

Size	Project Name	Rev
Custom	STD	2.0G

Date: 2007/03/26 Sheet 24 of 60

« Kennedy_Zhang »

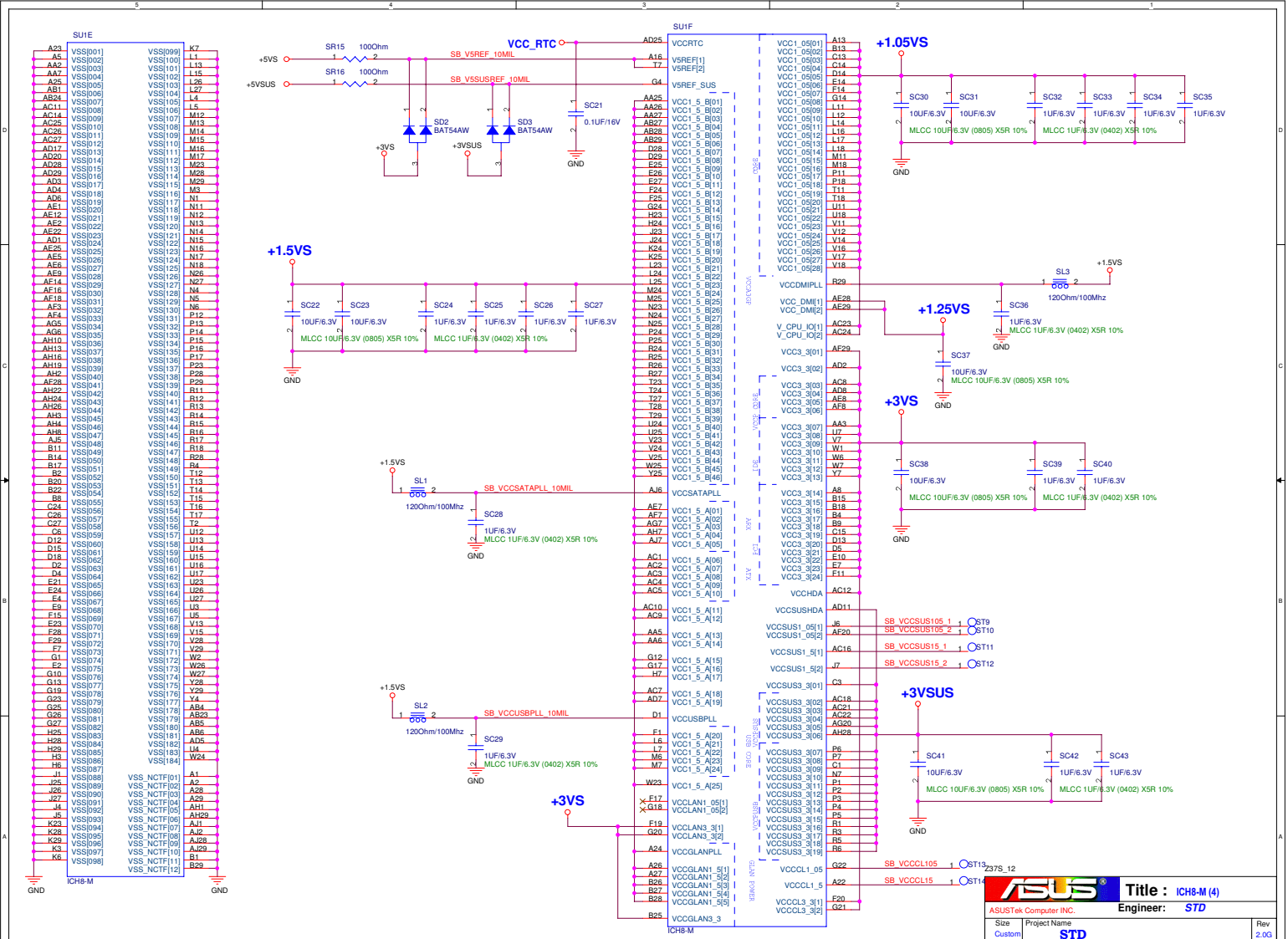

ASUSTek Computer INC.		Title : ICH8-M (4)	
Size	Project Name	Engineer :	STD
Custom			
Date : 2007.10.26	2007	Sheet	25 of 80

<< Kennedy_Zhang >>

SATA HDD

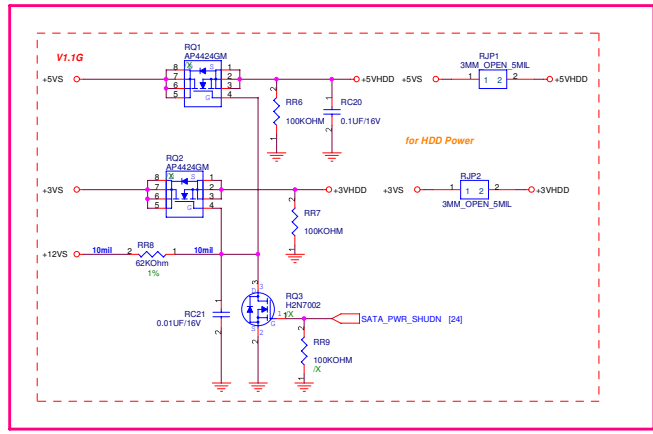
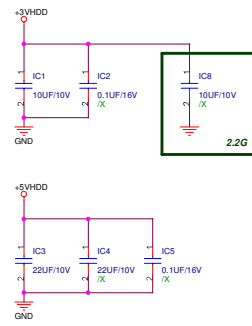
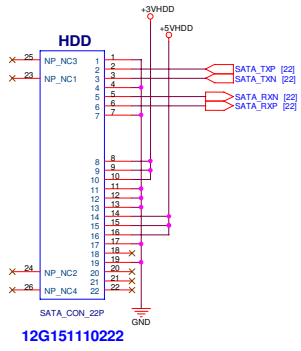

ODD

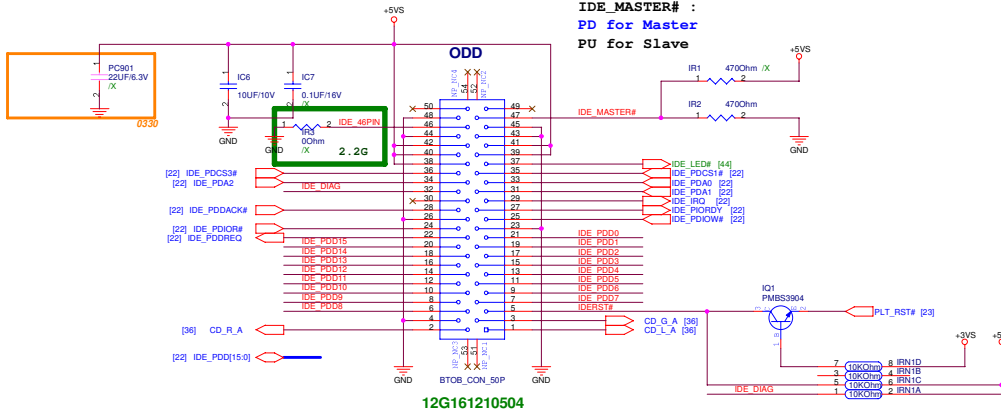

237S_12

ASUS		Title : SATA-HDD & ODD	
ASUSTek Computer INC.		Engineer: STD	
Size	Project Name	Rev	
Custom	STD	2.00	
Date: 11/04, 11/16, 2007	Sheet 26	of 30	

<< Kennedy_Zhang >>

All close to USB connectors

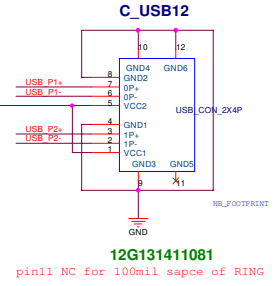
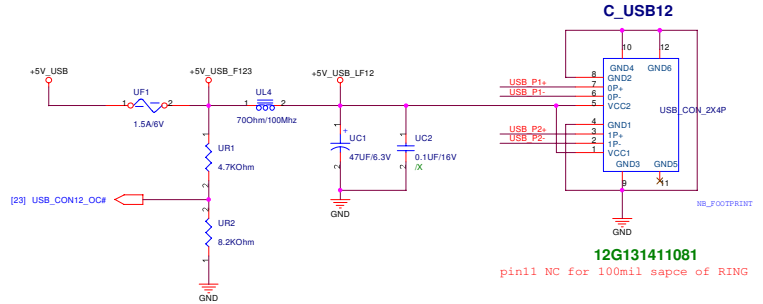
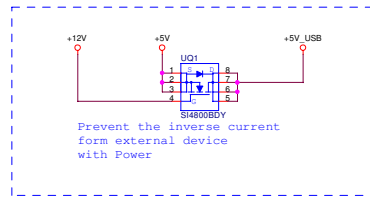
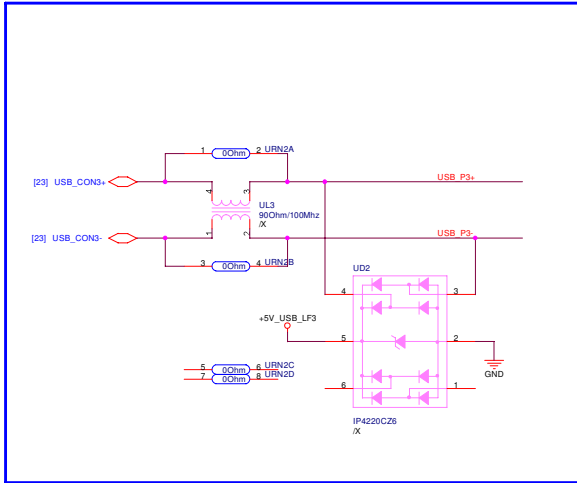
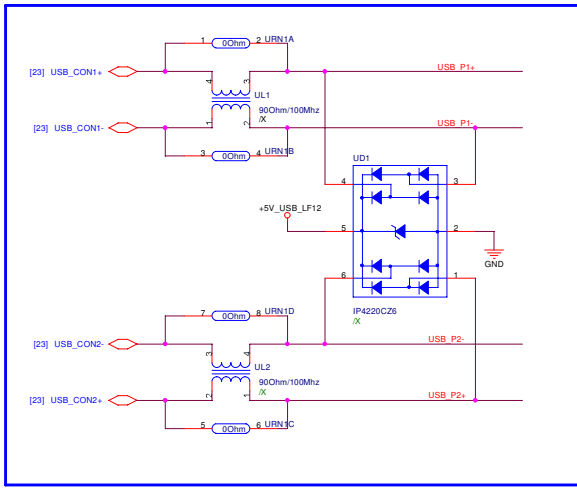

12G131411081
pin11 NC for 100mil sapce of RING

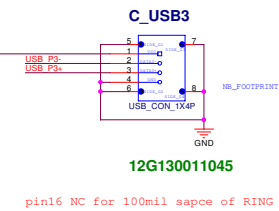
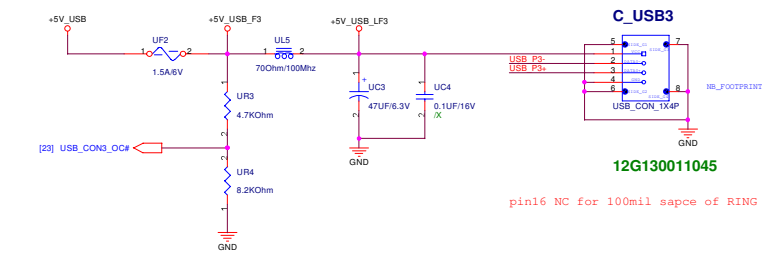

12G130011045
pin16 NC for 100mil sapce of RING

Z375_12

ASUS		Title : USB CONN	
ASUSTek Computer INC.		Engineer: STD	
Size	Project Name		Rev
A3	STD		2.0G
Date: 11/21/11	11/28, 2007	Sheet	27 of 60

<< Kennedy_Zhang >>

Bluetooth Connector

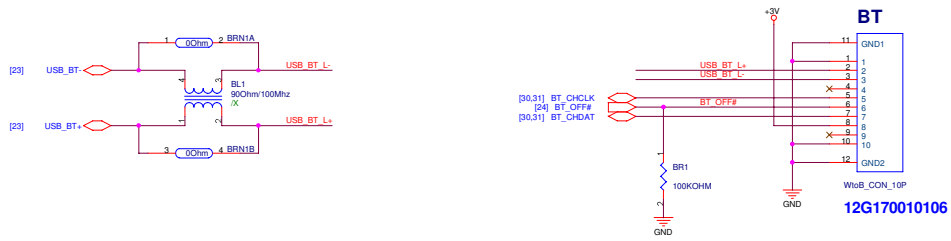

BT_OFF# : (connect to GPO, push-pull, default High)
 0 => BT Disabled
 1 => BT Enabled

Z37S_12

ASUS		Title : Blue Tooth	
ASUSTek Computer INC.		Engineer: STD	
Size	Project Name		Rev
Custom	STD		2.00
Date: 11/09/2007		Sheet 28	of 80

<< Kennedy_Zhang >>

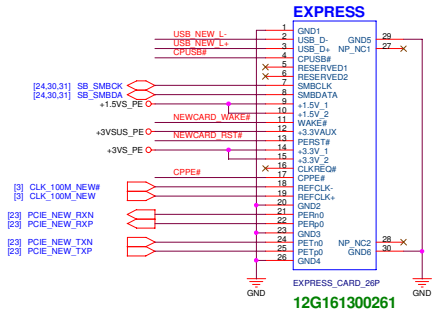
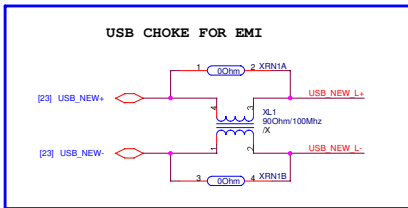
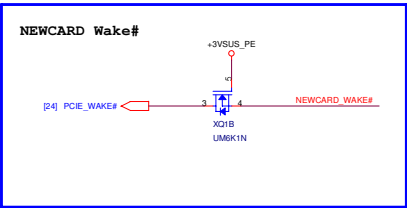
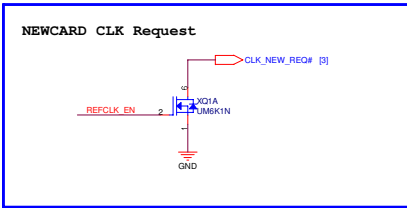
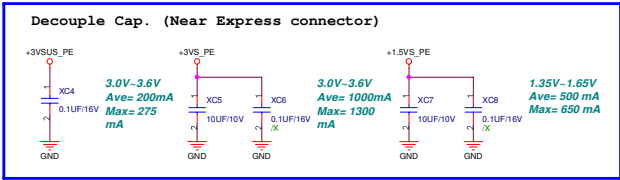
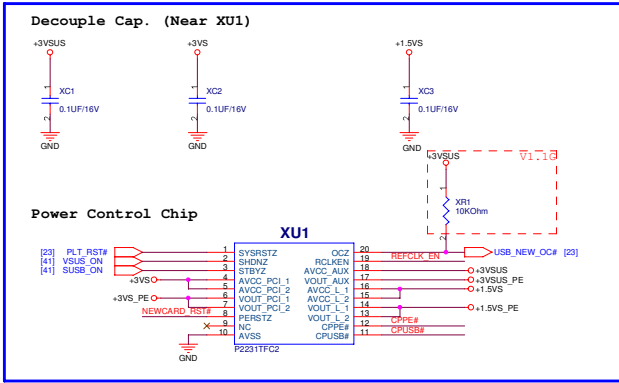

!! ExpressCard Standard 1.0:
 Change Pin7 from RESERVED to SMBCLK
 Change Pin8 from SMBDATA to SMBDATA
 Change Pin9 from SMBDATA to +1.5V

NewCard Ejector

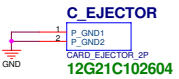

ASUS		Title : NEWCARD	
ASUSTek Computer INC.		Engineer: STD	
Size	Project Name		Rev
Custom	STD		2.0G
Date: 2007.11.26	Sheet: 29	of 60	

<< Kennedy_Zhang >>

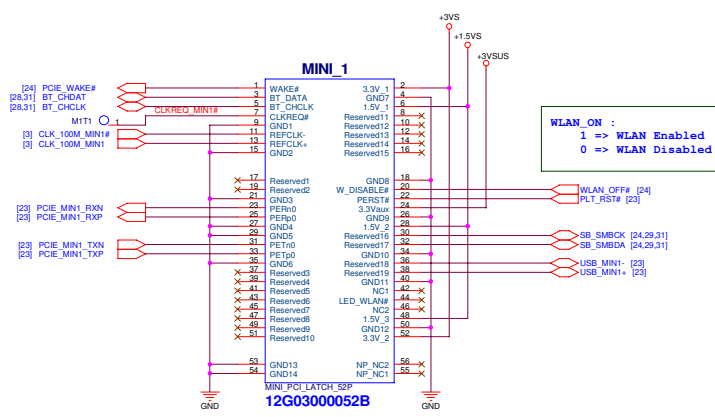
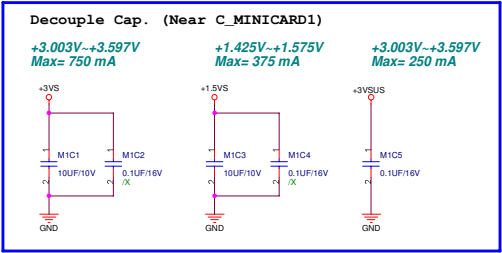

Z375_12

ASUS		Title : MINI CARD
ASUSTek Computer INC.		Engineer: STD
Size: Custom	Project Name: STD	Rev: 2.00
Date: 11/11/2007	Sheet: 30	of 60

<< Kennedy_Zhang >>

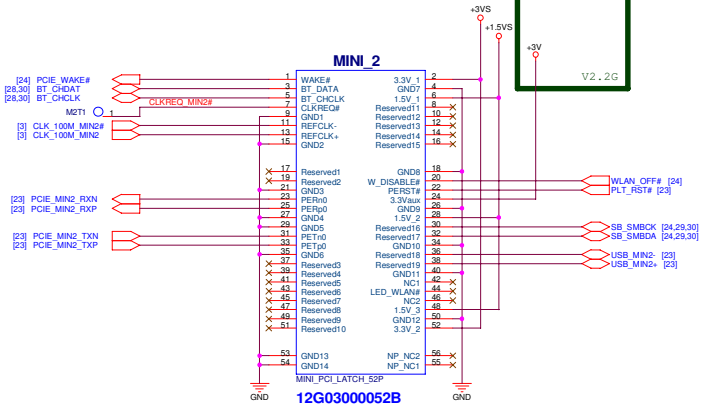
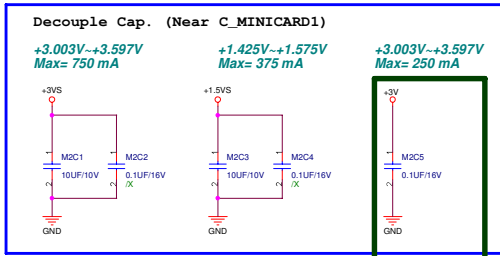

WLAN_ON :
 1 => WLAN Enabled
 0 => WLAN Disabled

Z376_12

ASUS		Title : MINI CARD
ASUSTek Computer INC.		Engineer: STD
Size	Project Name	Rev
Custom	STD	2.00
Date: 11/11/2007	Sheet	31 of 60

<< Kennedy_Zhang >>

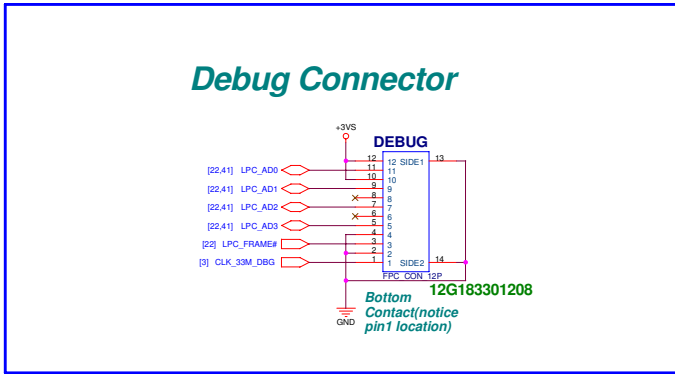
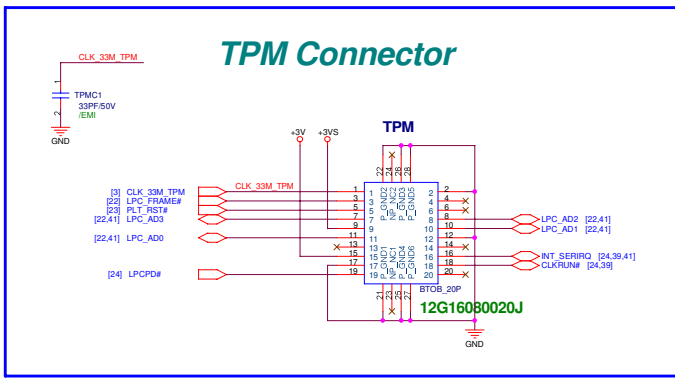

<< Kennedy_Zhang >>

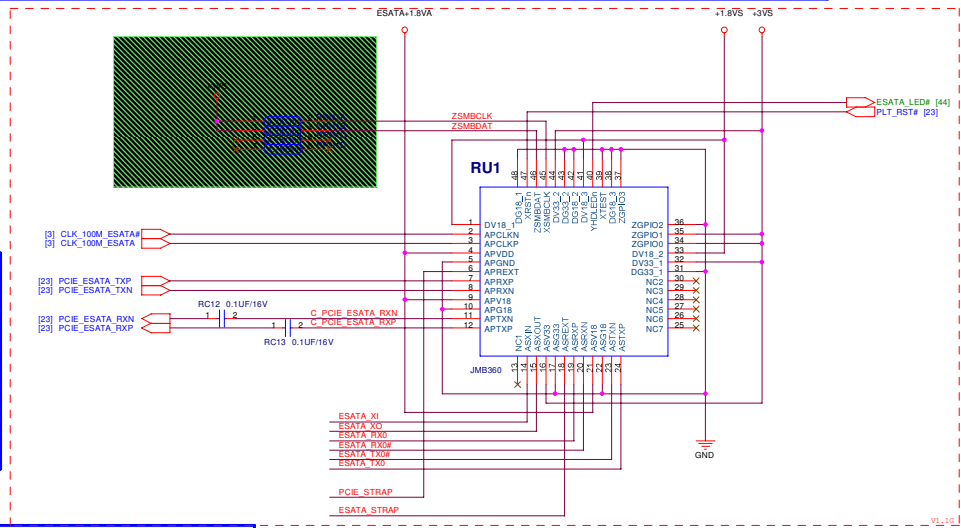
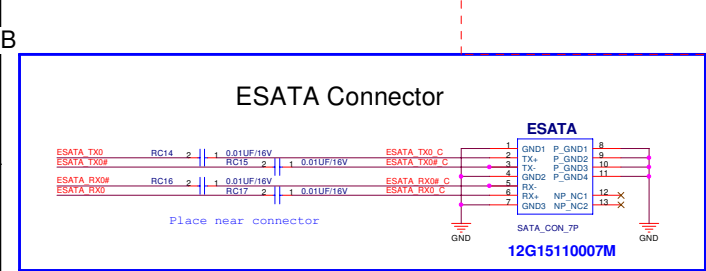
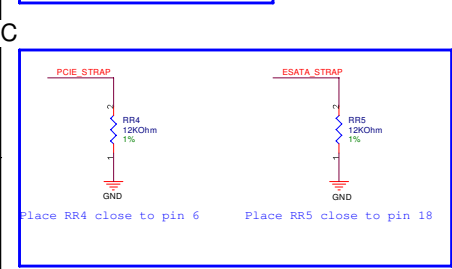
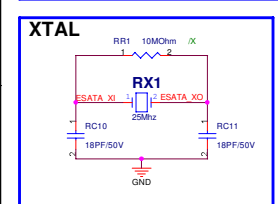
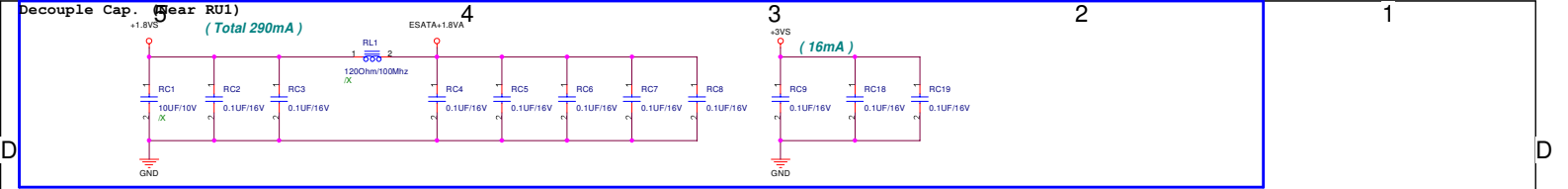

2375_12

ASUS		Title : ESATA JMB360	
ASUSTek Computer INC.		Engineer: STD	
Size A3	Project Name STD	Rev 2.0G	Date: 08/03, 11/18, 2007
Sheet 33 of 60			

<< Kennedy_Zhang >>

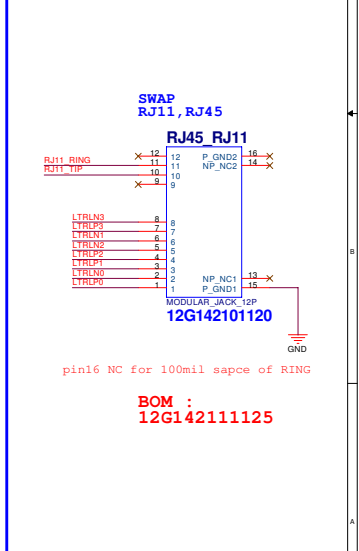
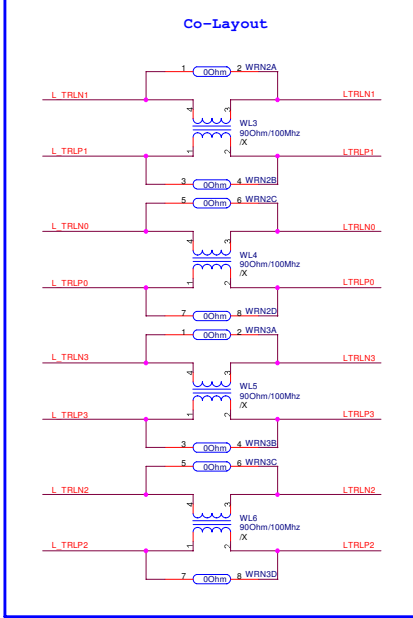
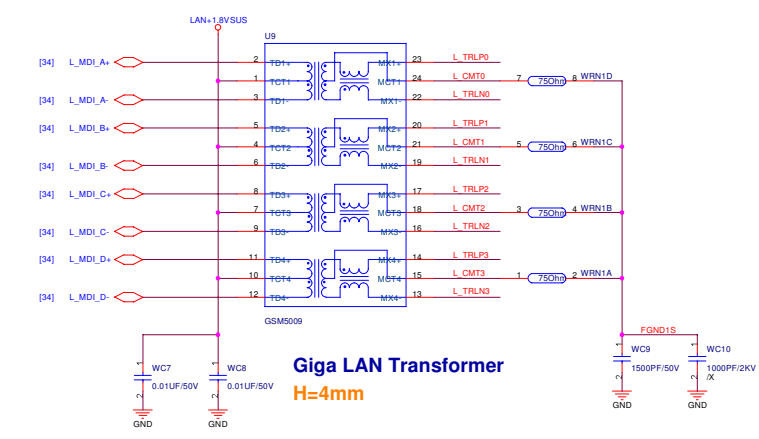
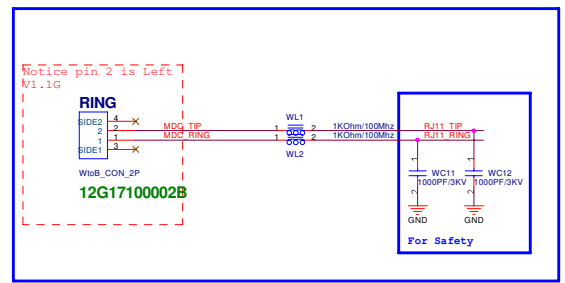
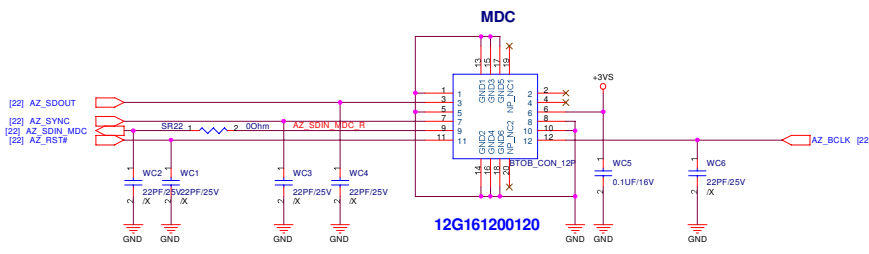

237S_12

ASUS Title : MDC / RJ45
 ASUSTek Computer INC. Engineer: STD

Size Project Name
 A3 STD

Date: 10/12/26/2007 Sheet 85 of 89

<< Kennedy_Zhang >>

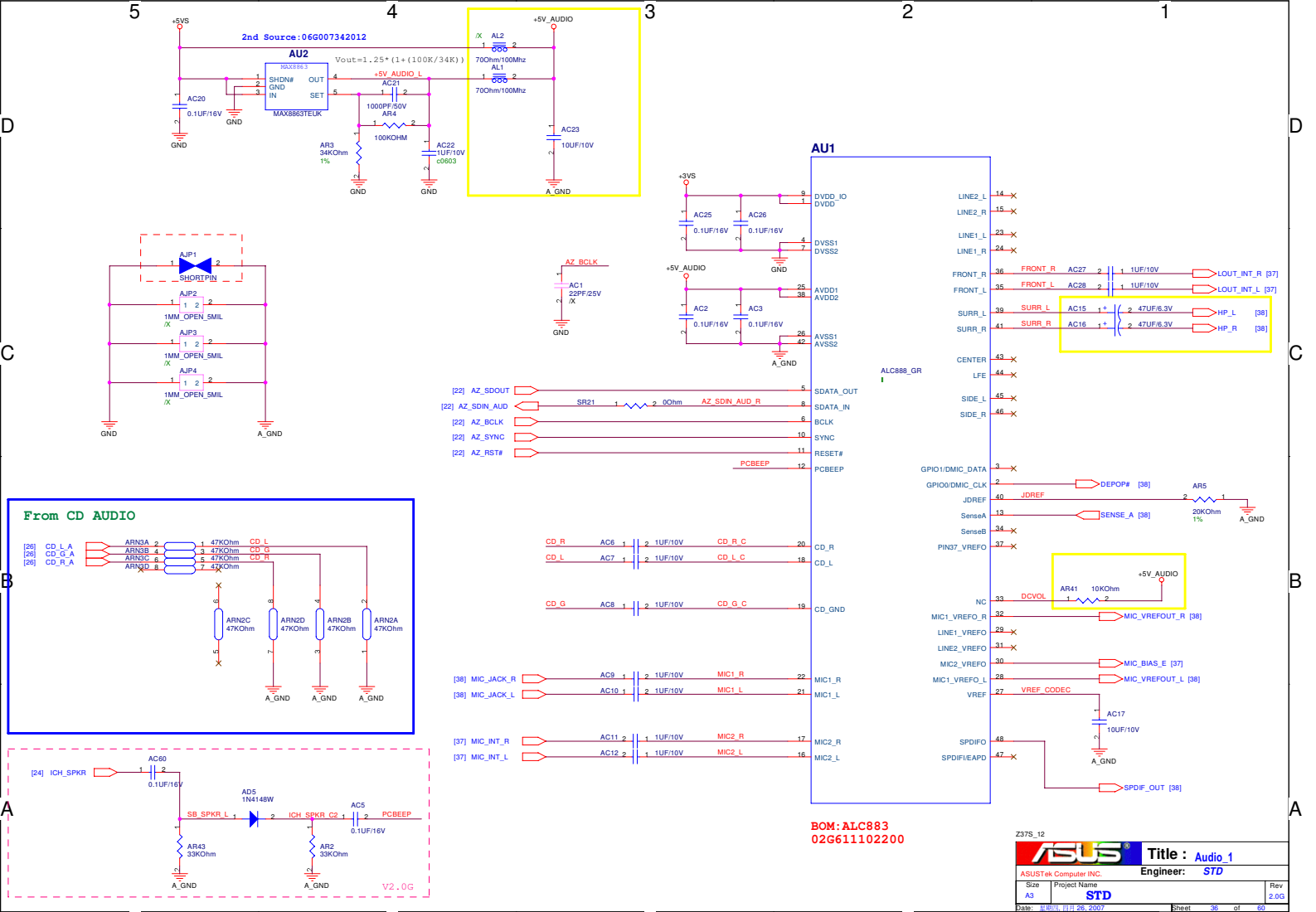

<< Kennedy_Zhang >>

Audio Amp.

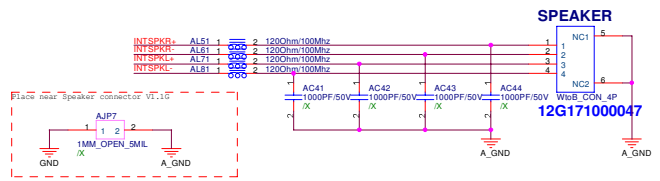
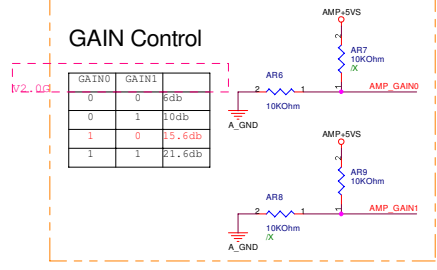
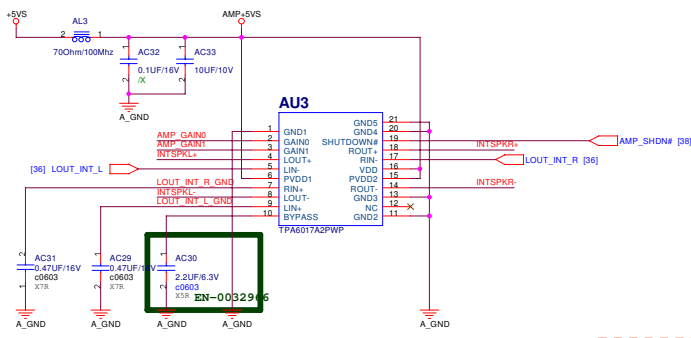

Internal MIC Amp.

FL = 33.86kHz, FH = 22.5kHz
Place Near INTMIC Connector

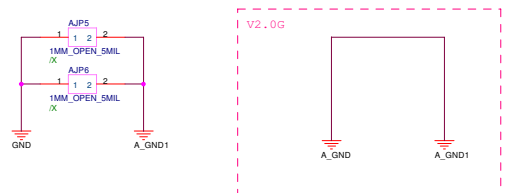
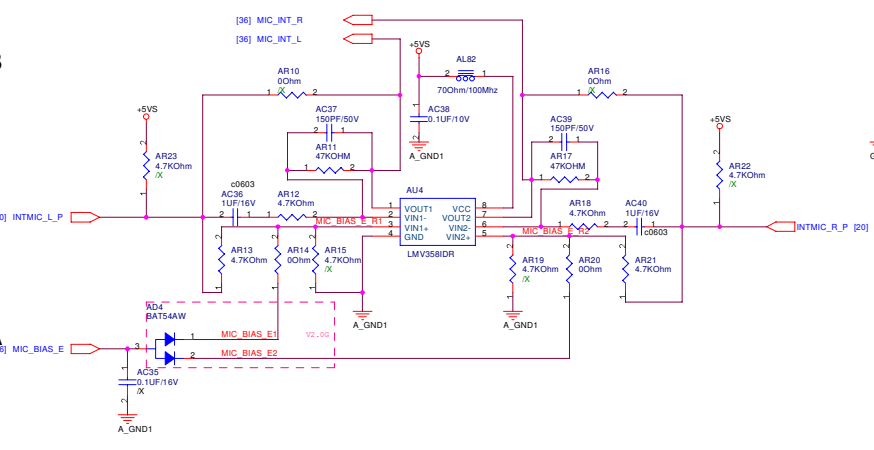

237S_12

ASUS		Title : Audio_2	
ASUSTek Computer INC.		Engineer: STD	
Size A3	Project Name STD	Rev 2.0G	
Date: 08/03/2007	Sheet 37	of	60

<< Kennedy_Zhang >>

Headphone & S/PDIF Jack

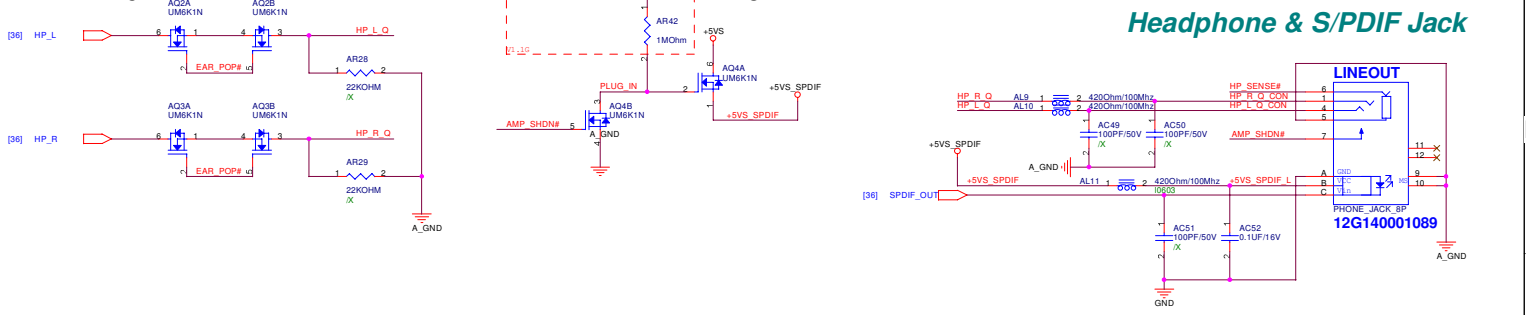

Microphone-In Jack

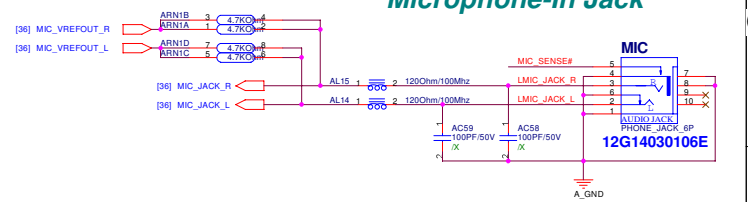

Anti POP for LINE_OUT

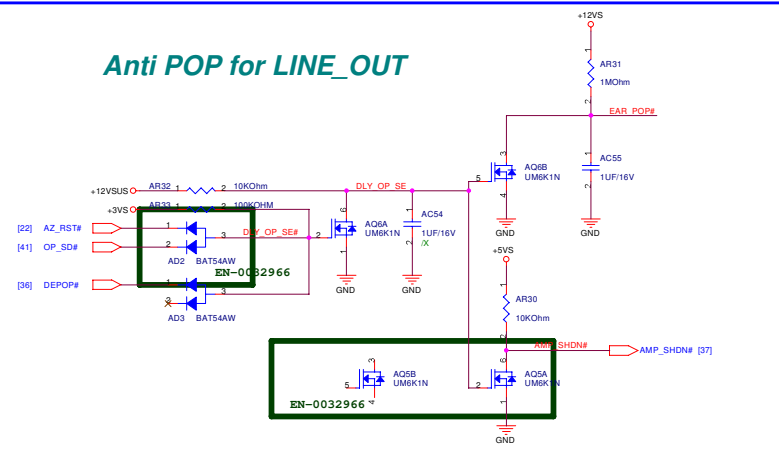

Jack Plug-in Detection

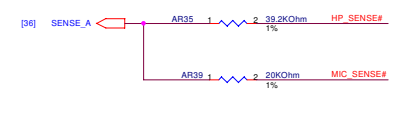

237S_12

ASUS		Title : Audio_3	
ASUSTek Computer INC.		Engineer: STD	
Size	Project Name		Rev
A3	STD		2.0G
Date: 08/03/2007		Sheet	38 of 60

<< Kennedy_Zhang >>

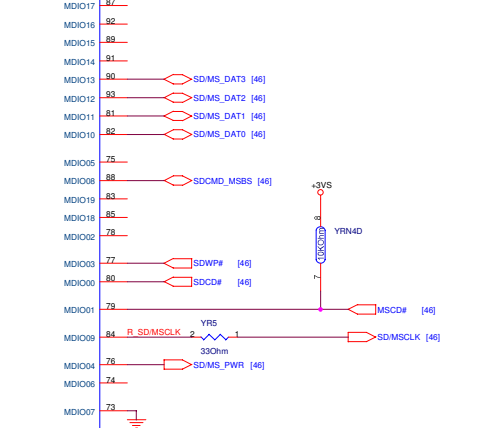
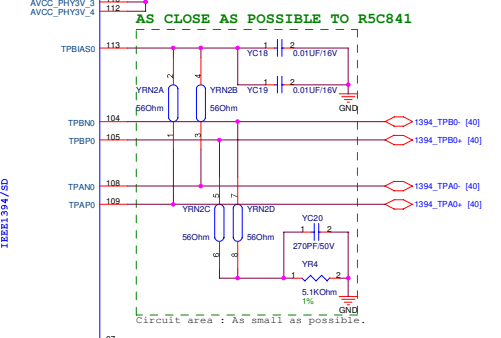
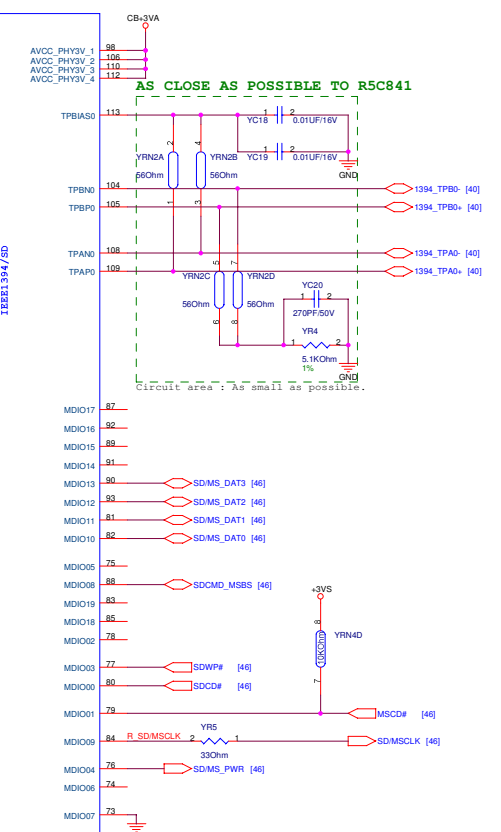
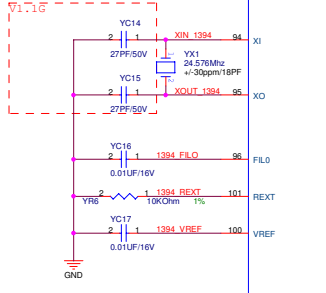
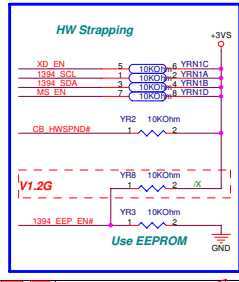
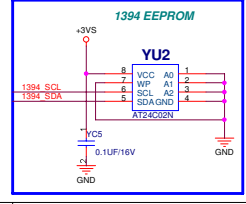
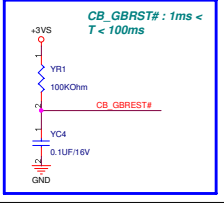
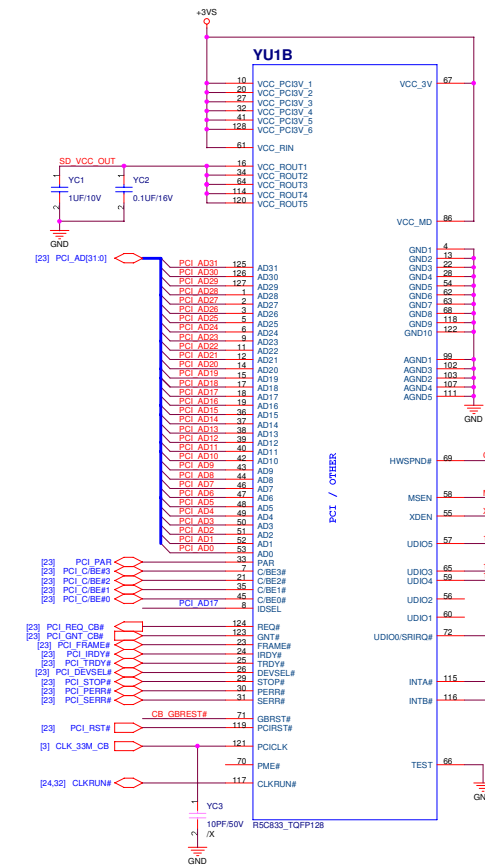
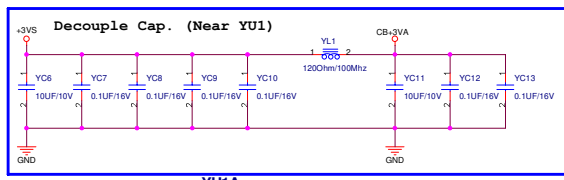

ASUS		Title : CARD1394-R5C832(1)	
ASUSTek Computer INC.	Project Name	Engineer:	STD
Size	Custom	Rev	2.00
Date: 2007.10.26	Sheet: 39	of	90

<< Kennedy_Zhang >>

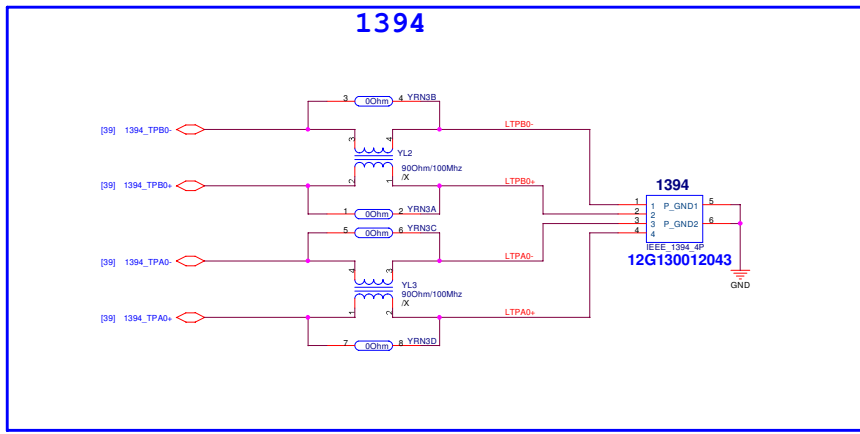

Z375_12

ASUS		Title 3394 CON
ASUSTek Computer Inc.		Engineer: STD
Size	Project Name	Rev
A3	STD	2.0G
Date: 11/26/2007	Sheet 40	of 60

<< Kennedy_Zhang >>

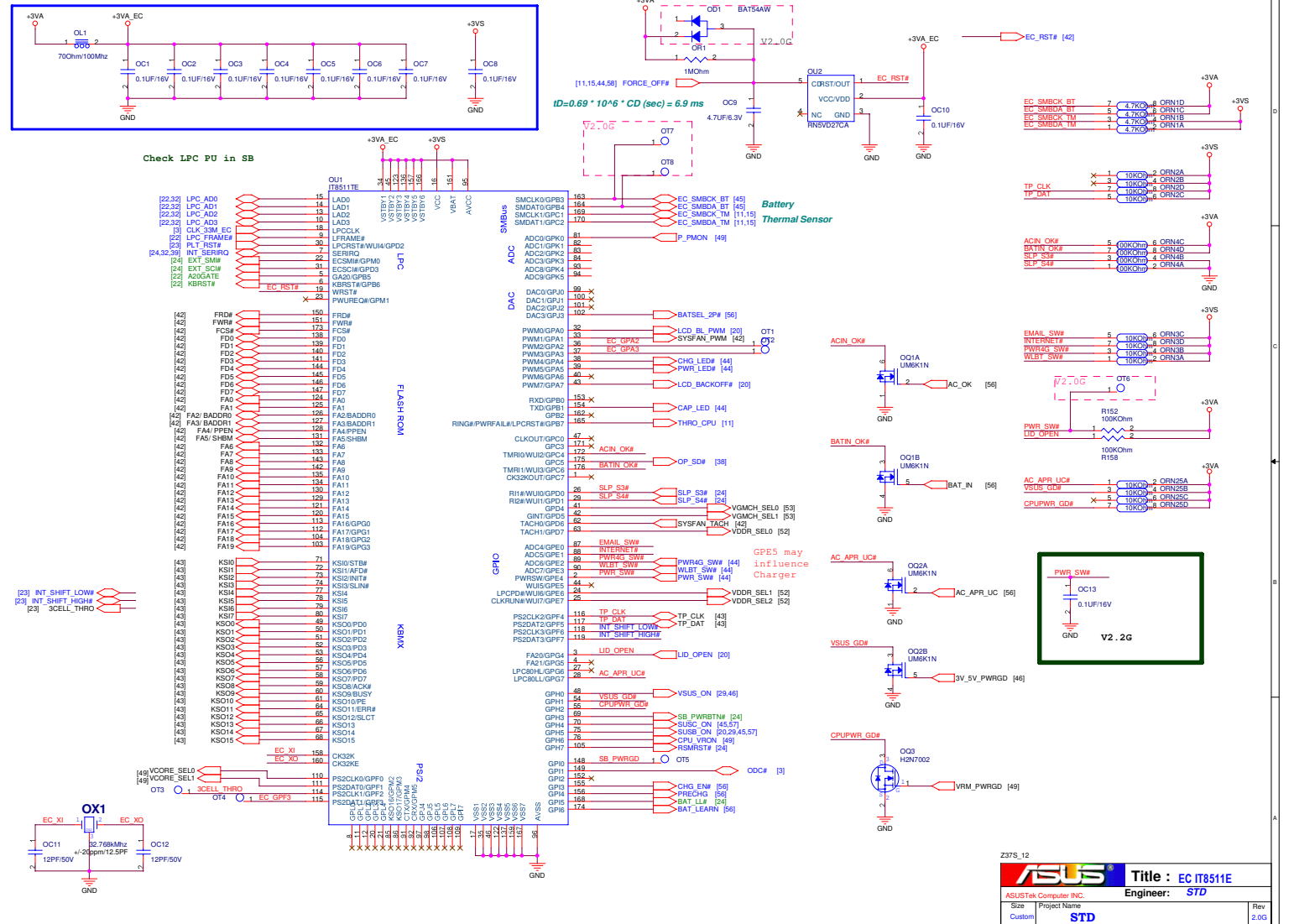

237S.12		ASUS Title: EC IT8511E	
ASUSTek Computer, INC.		Engineer: STD	
Size	Project Name	Rev	
Custom	STD	2.0G	
Date: 11/13/11 09:26:2007	Sheet: 41	of 60	

<< Kennedy_Zhang >>

ISA ROM

EC Hardware Strapping

[FA3/ BADDR1 : FA2/ BADDR0]

00: PNPCNG Access Register Pair Are 002Eh and 002Fh
 01: PNPCNG Access Register Pair Are 004Eh and 004Fh
 10: PNPCNG Access Register Pair Are Determined by EC Domain Registers SWCBALR and SWCBAHR.
 11: Reserved

FA4/ PPEN

0: Normal
 1: KBS Interface Pins Are Switched to Parallel Port Interface for In-System Programming

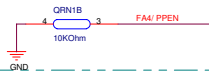

FA5/ SHBM

0: Disable Shared Memory with Host BIOS
 1: Enable Shared Memory with Host BIOS



Note: Sampled at VSTBY Power Up Reset

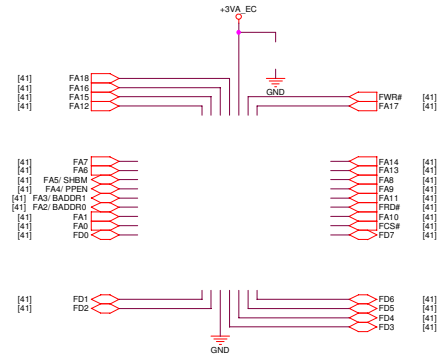

System Fan Connector

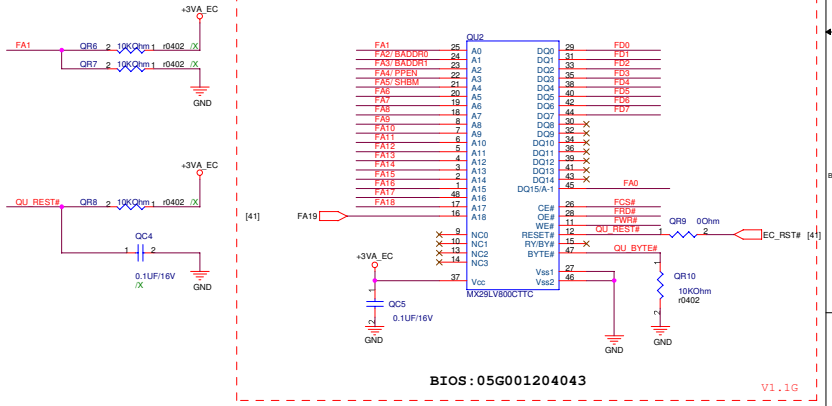
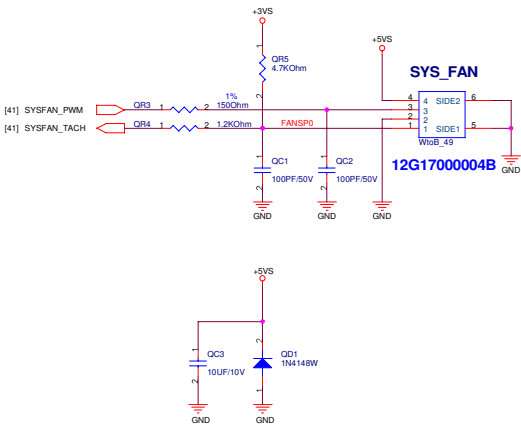

Z37S_12

ASUS		Title : ISA FLASH ROM	
ASUSTek Computer INC.		Engineer: STD	
Size	Project Name		Rev
Custom	STD		2.0G
Date: 2007.01.26	Sheet: 45	of 60	

<< Kennedy_Zhang >>

Keyboard Connector

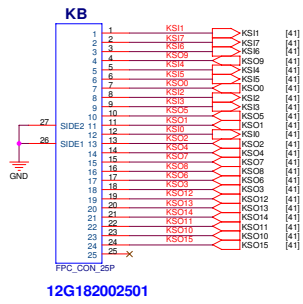

FOR EMI/ESD

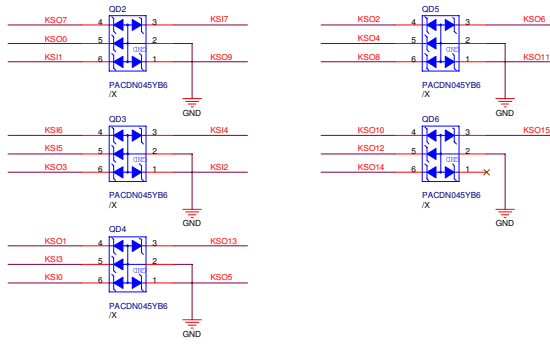

Fingerprint & TouchPad Connector

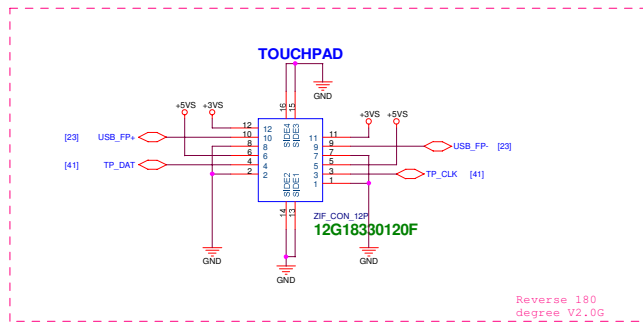

Z378_12

ASUS		Title : Touch Pad & KB	
ASUSTek Computer INC.		Engineer: STD	
Size	Project Name	Rev	
Custom	STD	2.0G	
Date: 11/04/11 09:26:2007	Sheet	43	of 50

<< Kennedy_Zhang >>

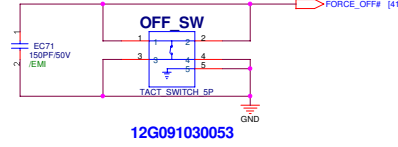
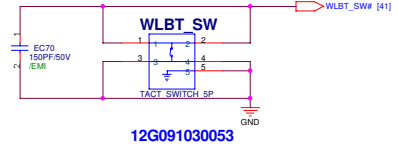
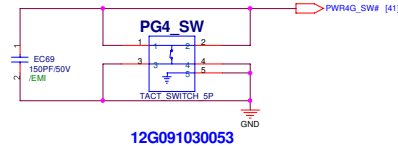
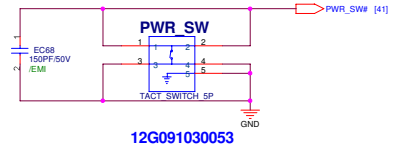
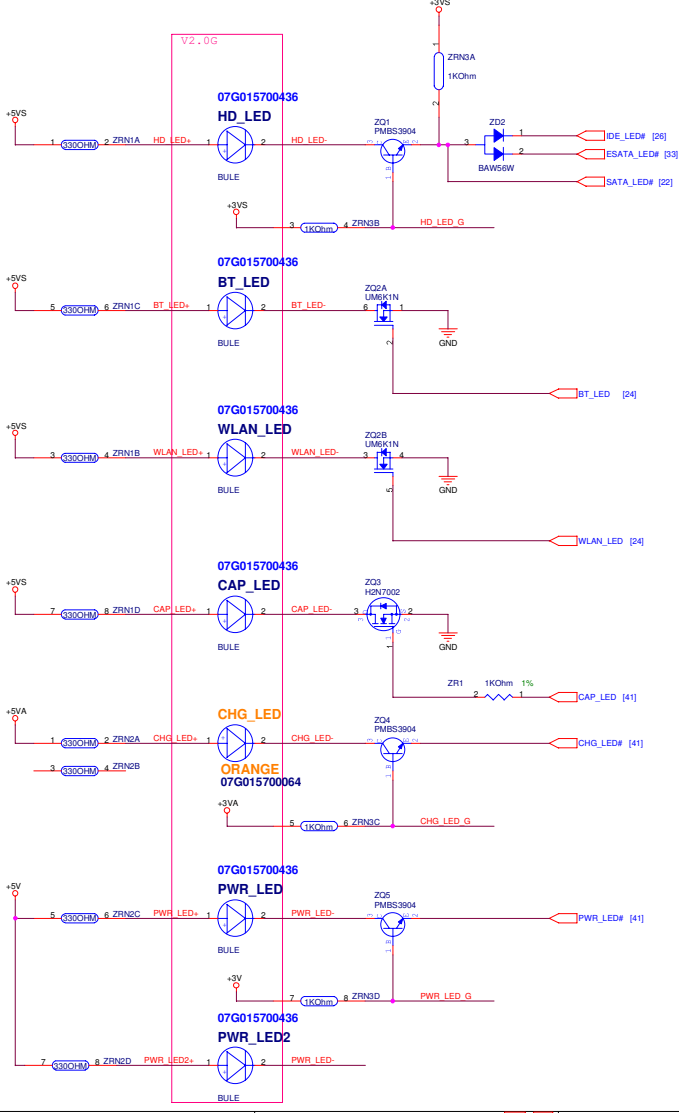

Z379_12

ASUS		Title : LED & SW	
ASUSTek Computer INC.		Engineer: STD	
Size	Project Name	Rev	
Custom	STD	2.03	
Date: 11/04/11 09:26:2007	Sheet	44	of 50

<< Kennedy_Zhang >>

DC-IN Connector

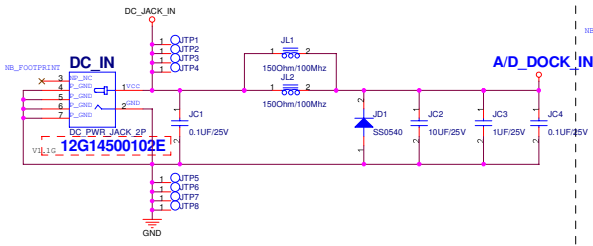

BAT-IN Connector

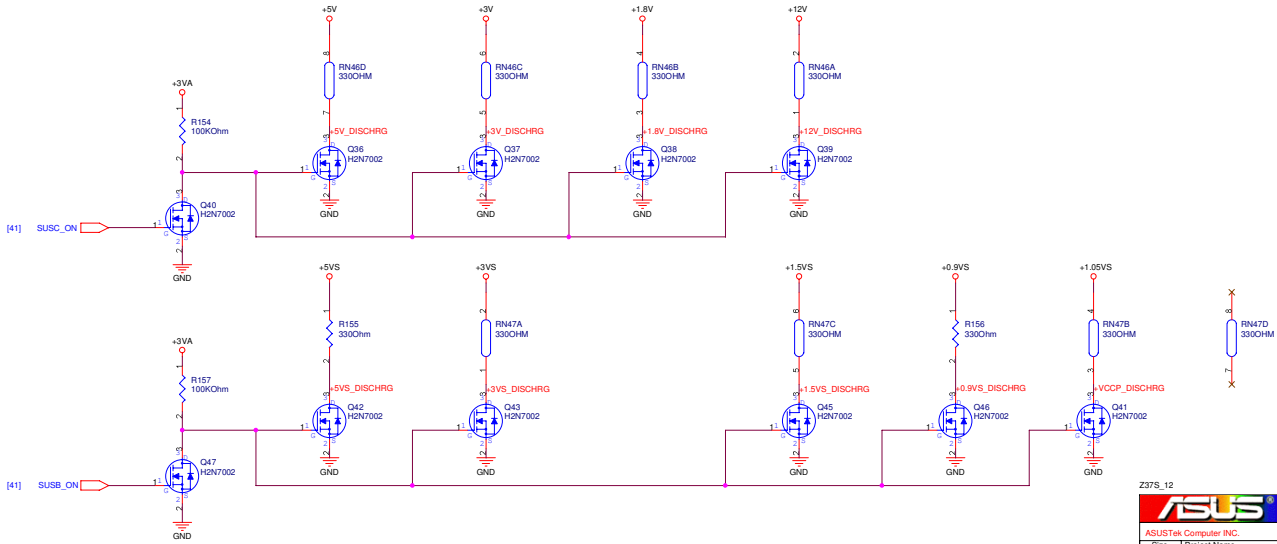
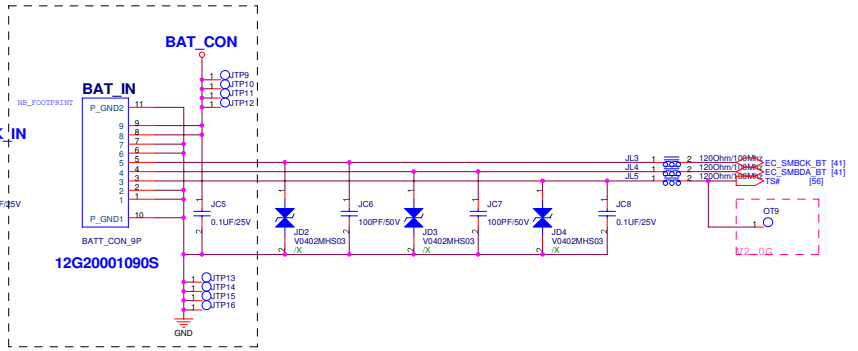

237S_12

ASUS		Title : DC IN & BAT IN	
ASUSTek Computer INC.		Engineer: STD	
Size	Project Name	Rev	
Custom	STD	2.0G	
Date: 2007.11.26	Sheet: 45	of	60

<< Kennedy_Zhang >>

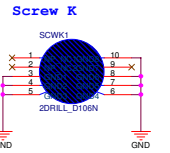
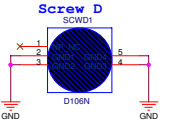
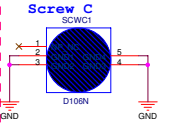
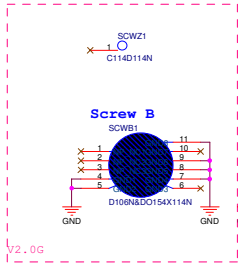
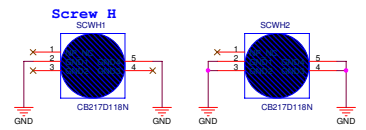
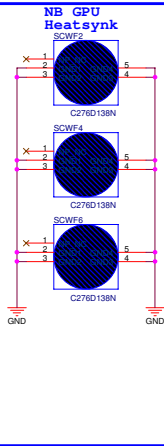
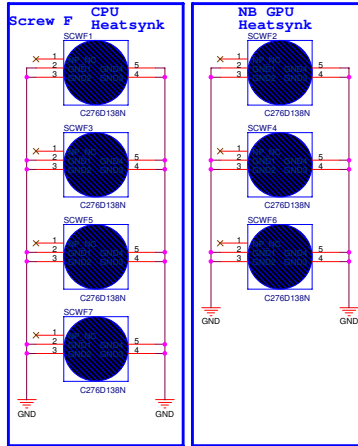
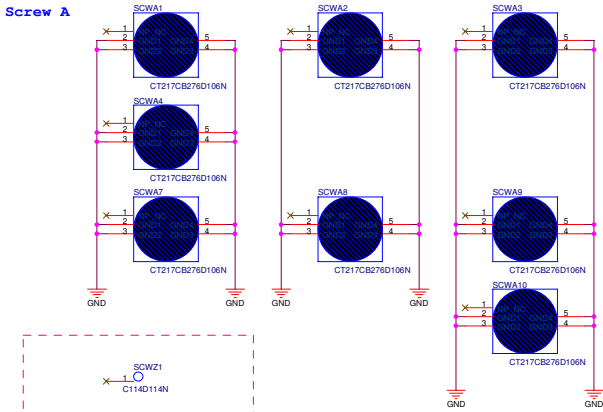
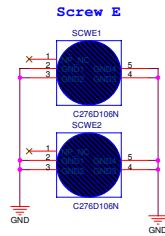
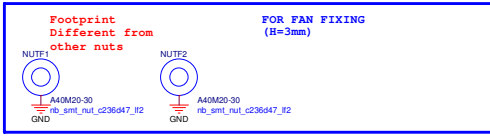
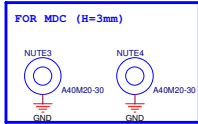
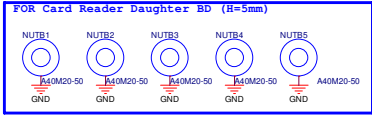
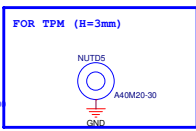
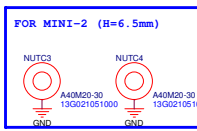
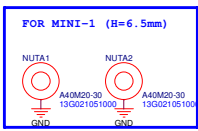

237S_12

pin9 NC for 100mil sapce of RING

		Title : Screw Hole	
ASUSTek Computer INC.		Engineer: STD	
Size	Project Name		Rev
Custom	STD		2.0G
Date: 11/14/11 09:26:2007		Sheet	47 of 60

<< Kennedy_Zhang >>

5

4

3

2

1

D

D

C

C

B

B

A

A

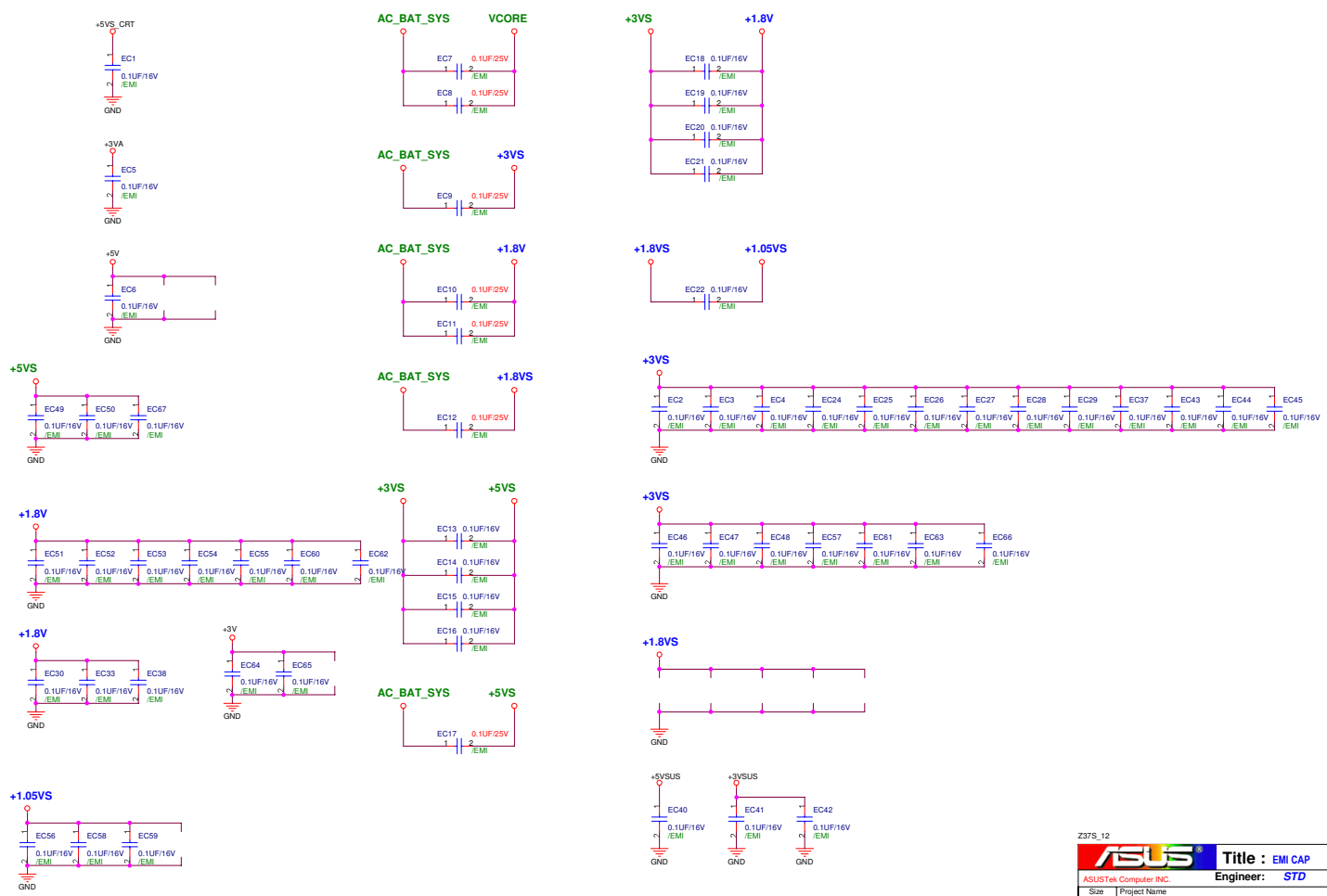

Z37S_12

ASUS		Title : EMI CAP
ASUSTek Computer INC.		Engineer: STD
Size :	Project Name :	Rev :
Custom :	STD	2.00
Date: 11/01/11/28/2007	Sheet: 48	of 69

« Kennedy_Zhang »

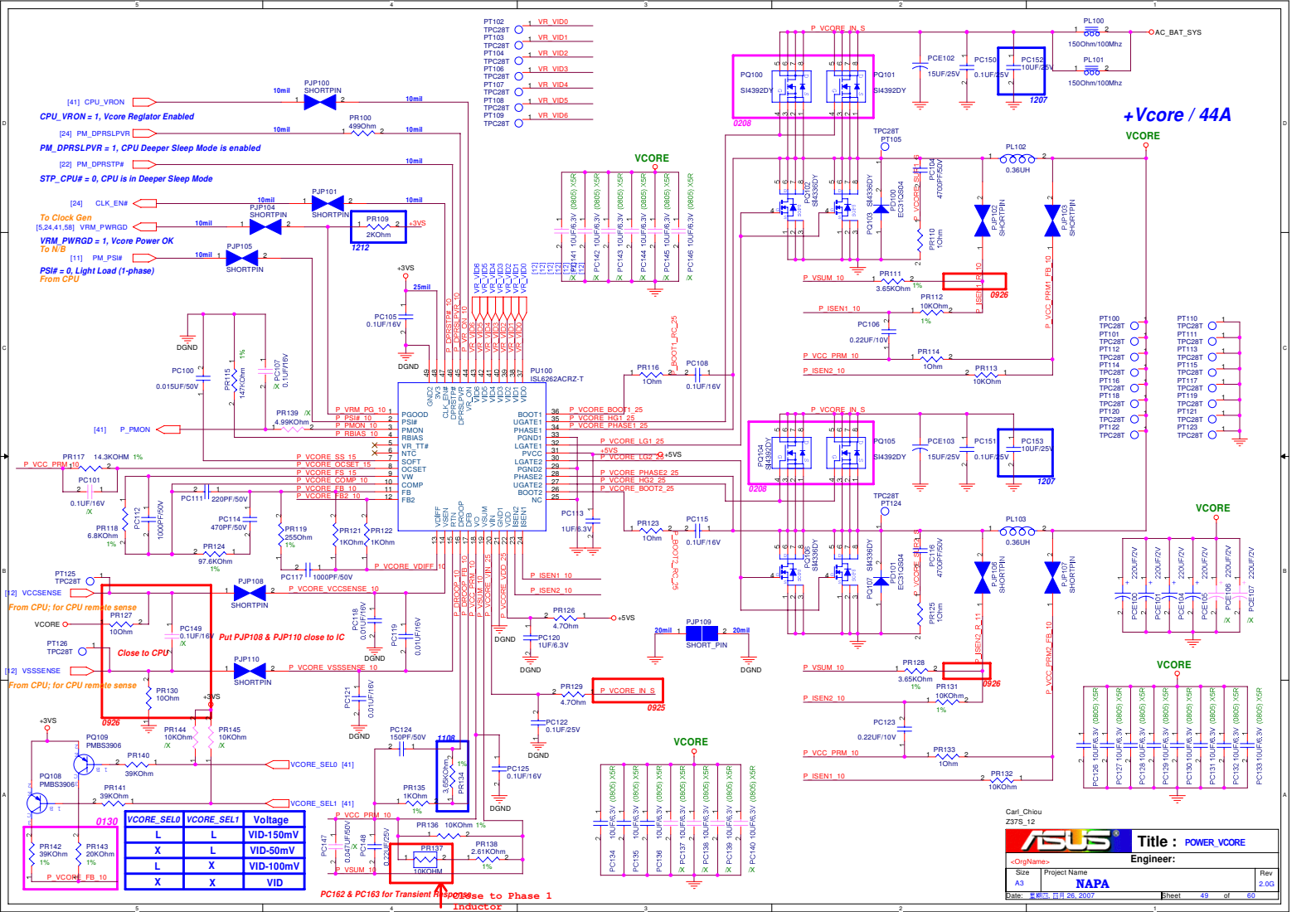

<< Kennedy_Zhang >>

Put these elements close to daughter board !!

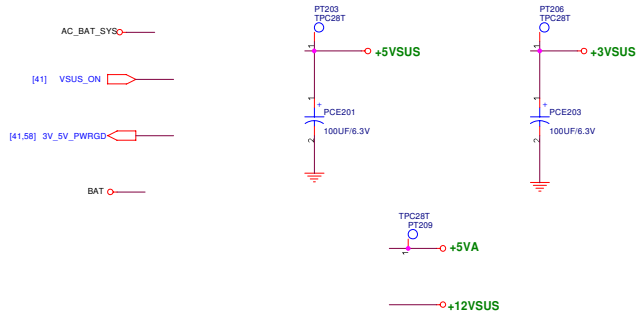

Z375_12

		Title : POWER_SYSTEM	
-<OrigName>		Engineer:	
Size	Project Name	Rev	
A3	NAPA	2.0G	
Date:	11/11/2007	Sheet	50 of 50

<< Kennedy_Zhang >>

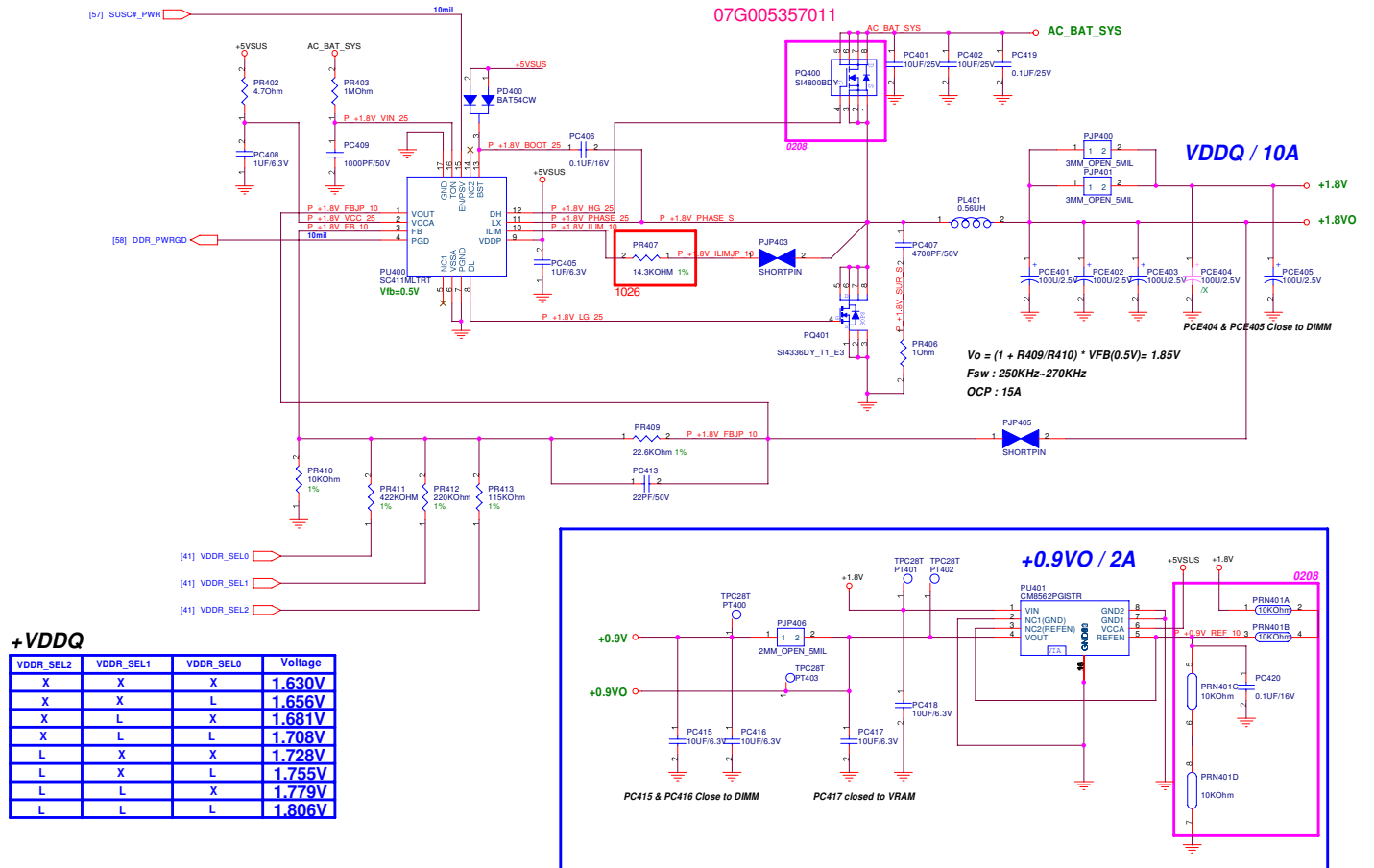

$$V_o = (1 + R_{409}/R_{410}) * V_{FB}(0.5V) = 1.85V$$

Fsw : 250KHz-270KHz
OCP : 15A

<< Kennedy_Zhang >>

Enable Signal :
 Implemet Intel 965GM --> PR502
 Implemet NB8M Chipset --> PR500

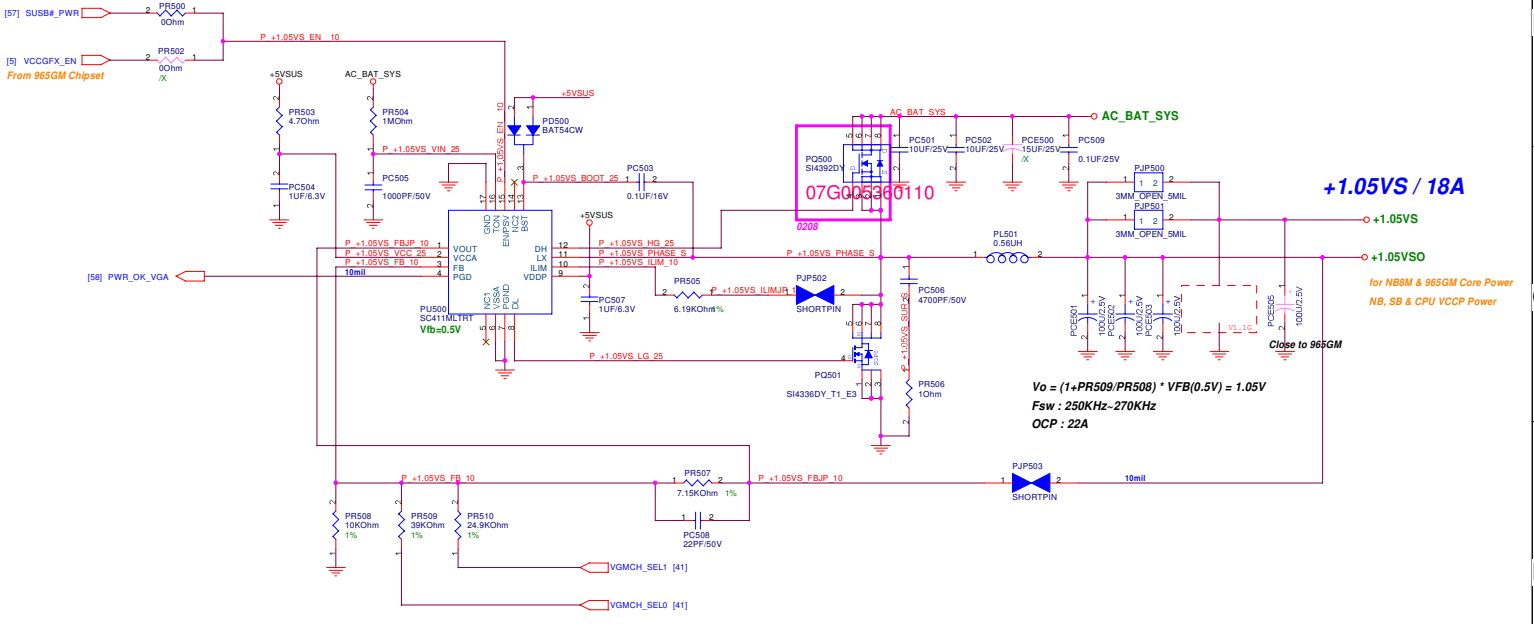

+1.05VS

VGMCH_SEL0	VGMCH_SEL1	Voltage
L	L	1.093V
X	L	1.001V
L	X	0.949V
X	X	0.857V

$V_o = (1 + PR509/PR508) * VFB(0.5V) = 1.05V$
 $F_{sw} : 250KHz - 270KHz$
 $OCP : 22A$

Z37S_12

ASUS Title : <Title>

ASUSTek COMPUTER Inc. Engineer: Carl Chiou

Size	Project Name	Rev
A3	<Doc>	2.0G

Date: 11/11/26/2007 Sheet 53 of 60

<< Kennedy_Zhang >>

Z375_12

		Title : POWER, VGA, CORE & RAM
Engineer:		
Size	Project Name	Rev
A3	NAPA	2.0G
Date:	11/11/2007	Sheet 54 of 60

<< Kennedy_Zhang >>

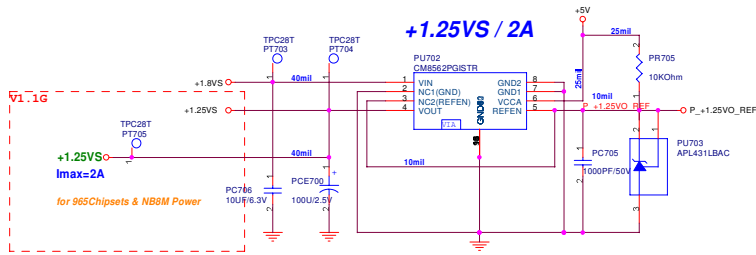
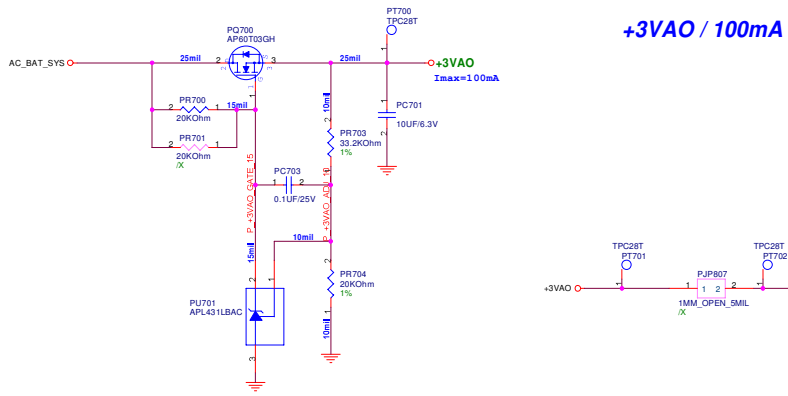

Z376_12

ASUS		Title : POWER_IO_+3VA & +2.5V	
Engineer:			
<OrigName>	Project Name		
Size	A3	NAPA	Rev 2.0G
Date: 11/01/11 11:26:2007	Sheet 55 of 60		

<< Kennedy_Zhang >>

SUSC#_PWR POWER

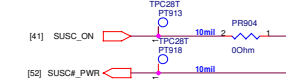
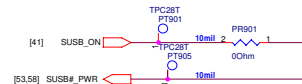
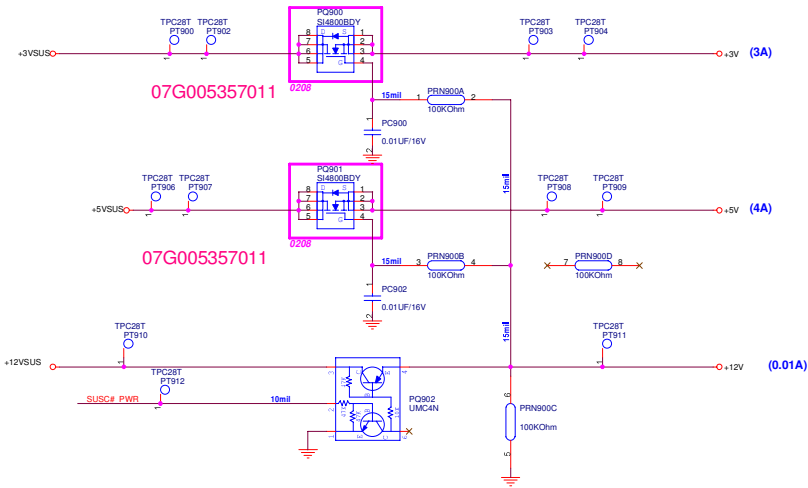

SUSB#_PWR POWER

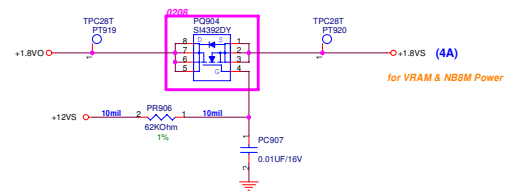
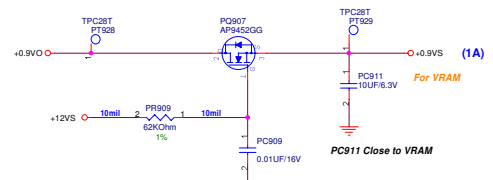
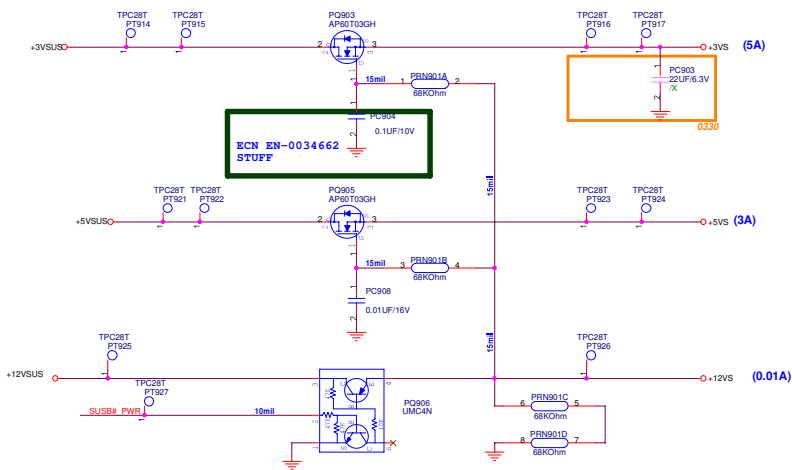

ASUS		Title : POWER_LOAD_SWITCH	
Size	Project Name	Engineer:	
Custom	NAPA		
Date: 11/01/2007	Sheet: 57	of 80	

<< Kennedy_Zhang >>

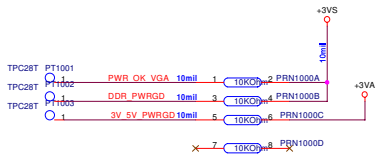

Power Good Detector

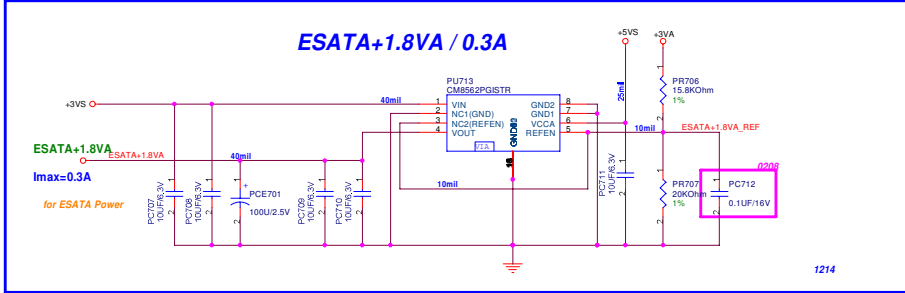
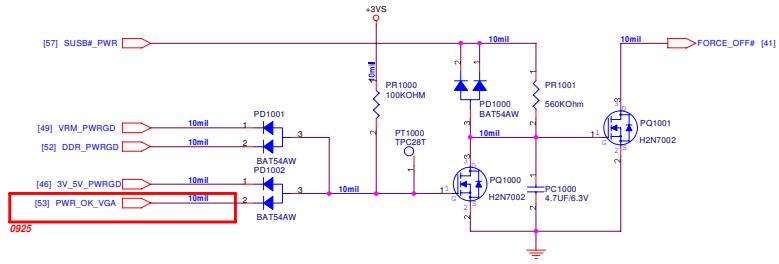

Z375_12

ASUS		Title : POWER_DETECT
Engineer:		
Size	Project Name	Rev
A3	NAPA	2.0G
Date: 11/21/11 28, 2007	Sheet 56	of 60

<< Kennedy_Zhang >>

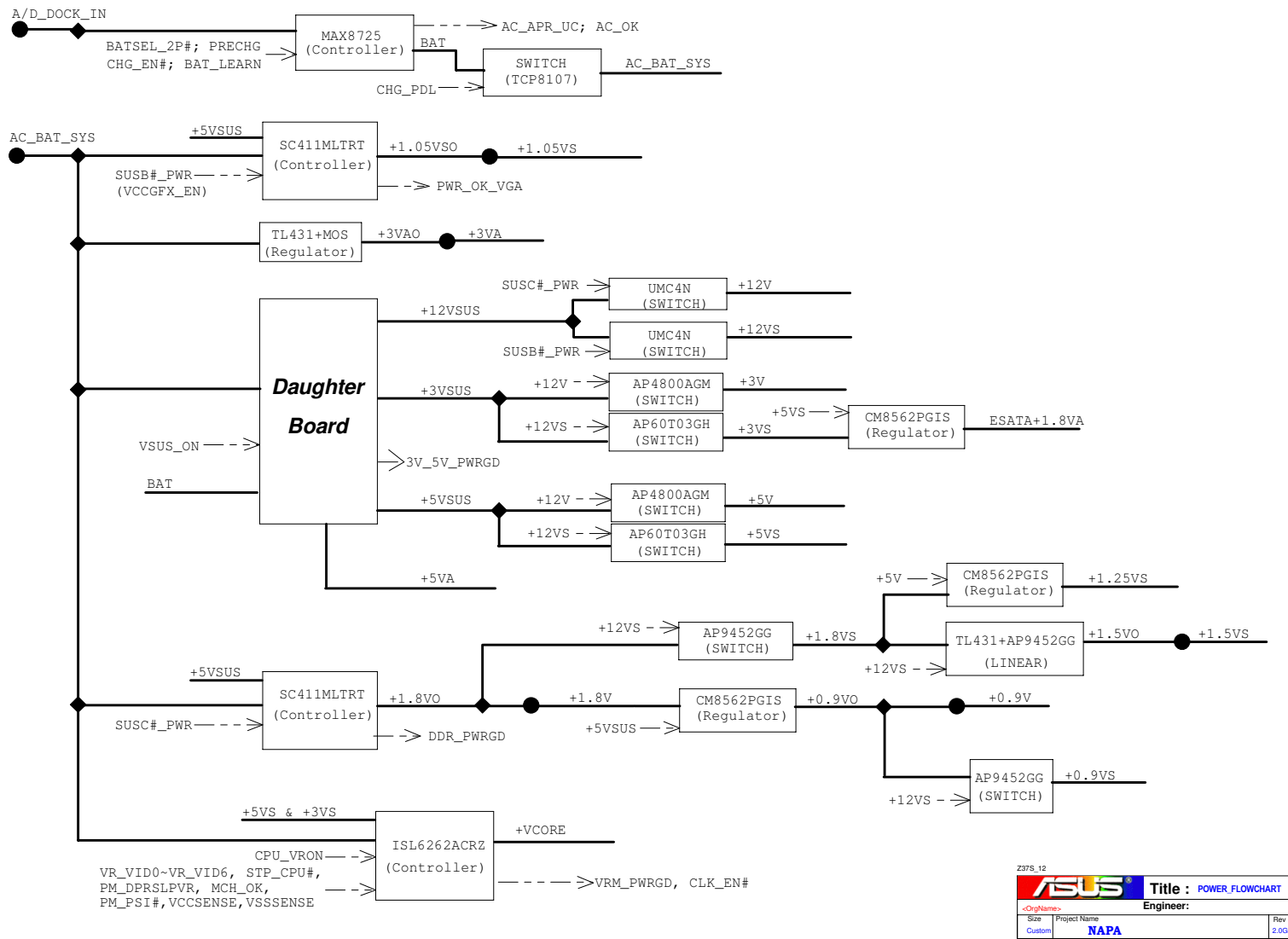

237S_12

		Title : POWER FLOWCHART	
Engineer:			
Size	Project Name	Rev	
Custom	NAPA	2.00	
Date: 11/01/2007		Sheet: 69	of 90

<< Kennedy_Zhang >>

Z37S_12

		Title : POWER_SIGNAL	
<OrigName>		Engineer: Carl Chiu	
Size	Project Name		Rev
Custom	NAPA		2.00
Date: 11/01/2007		Sheet	60 of 60

<< Kennedy_Zhang >>