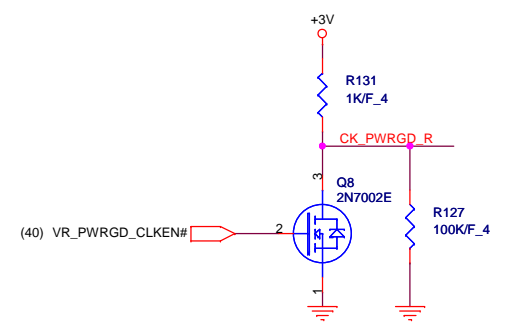
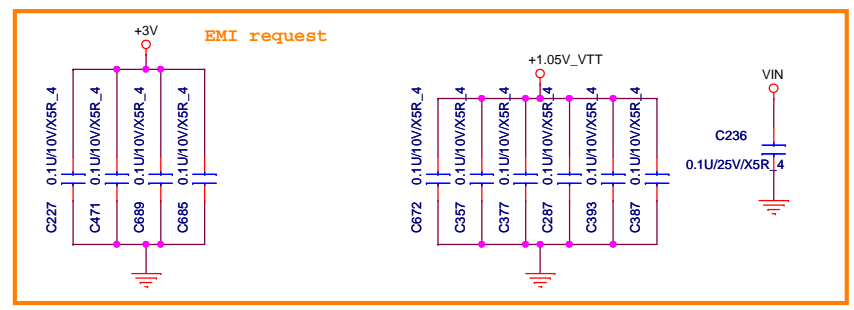
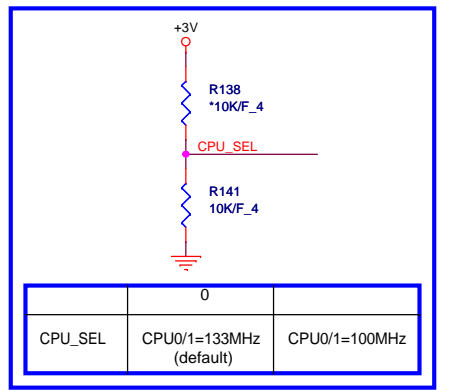
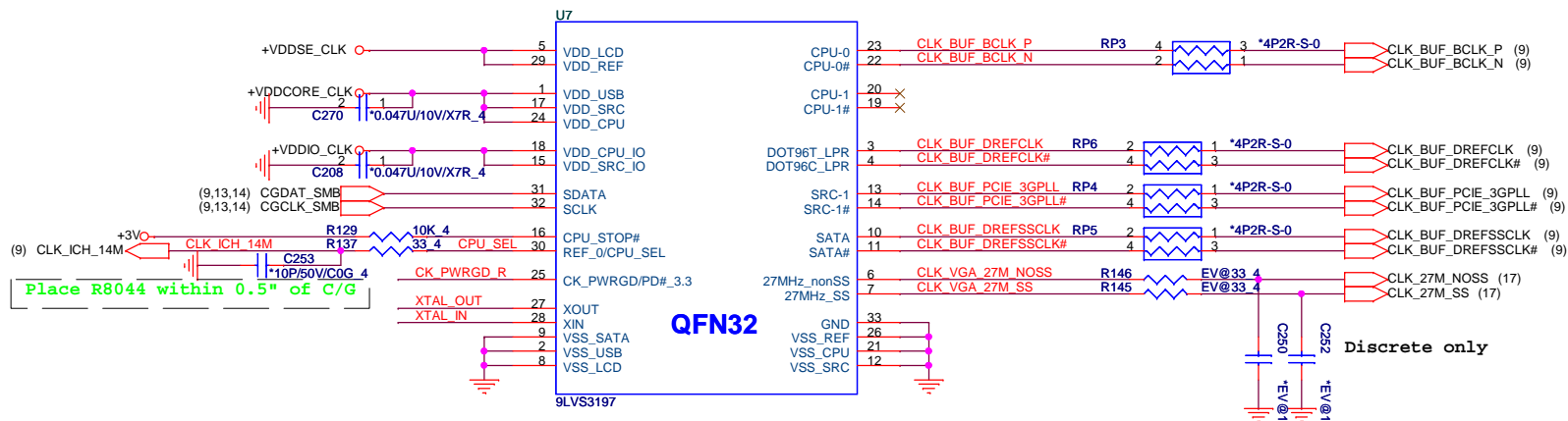
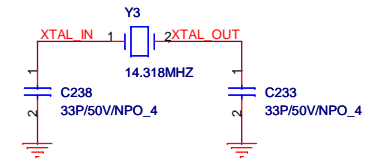
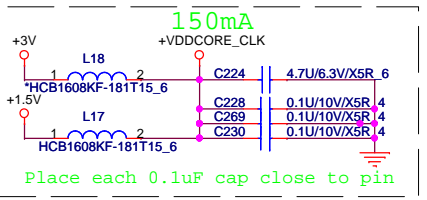
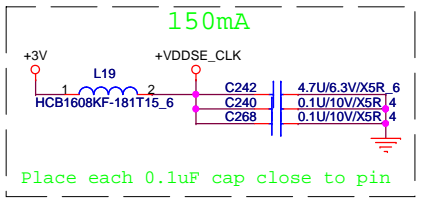
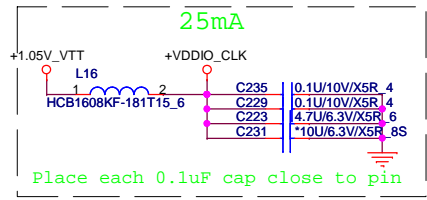

Table of Contents

PAGE	DESCRIPTION
1	Schematic Block Diagram
2	Front Page
3	CLOCK GENERATOR
4-7	Arrandale CPU
8-12	Ibex Peak-M
13-14	DDRIII SO-DIMM
15-19	Discreate VGA (N11M-GE2)
20	LCD + Camera Conn.
21	CRT Conn.
22	HDMI Conn.
23	ATHEROS (AR8151/AR8152)
24	CARD READER(OZ600FJ)
25	AL272/AMP/MIC/SPK
26	USB x 2 /USB+ ESATA
27	USB X2/SIM_CARD/LEDs/RF
28	MINI-Card (WLAN)
29	MINI-Card (WWAN/SSD)
33	ONFI
34	Express Card
35	K/B & T/P
36	BLUETOOTH
37	FAN & Thermal
38	G-Sensor
39	B To B Conn.
40	ITPM & RFID EEPROM
41	KBC IT8502E
42	HOLD & SKEW
43	Discharge
44	Charger
45	DDR3 (TPS5116REGR)
46	1.05V_VTT & 1.05_PCH (RT8204)
47	3V/5V (MAX17101)
48	CPU (MAX17082)
49	DIS_GFX_VCC (MAX8792)
50	DIS_1.8V_RUN (OZ8116LN)
51	Power Block Dianram
52	XDP
53	Revision & Schematic Value Description
54	BOM Matrix Table

Power States

POWER PLANE	VOLTAGE	PAGE	DESCRIPTION	CONTROL SIGNAL	ACTIVE IN
VIN	10V--+20V	23,32,43,44,45,46,47,48,49,50	MAIN POWER		S0-S5
+3VRTC	+3.0V--+3.3V	9,12,41	RTC		S0-S5
3VPCU	+3.3V	9,23,27,30,32,35,39,41,43,44,47	ITE8052 POWER	3V5V_EN	S0-S5
5VPCU	+5V	14,43,44,45,46,47,49,50	DC/DC POWER IC SOURCE	3V5V_EN	S0-S5
+15V	+15V	23,38,43,45,46,47	LARGE POWER	3V5V_EN	S0-S5
LANVCC	+3.3V	27,43	LAN POWER	LAN_ON	
5V_S5	+5V	12,29,30,43	PCH SUS POWER	S5_ON	S0-S3
3V_S5	+3.3V	8,9,10,11,12,43,52	Sys Management,PCH Resume Well,Intel HD Audio,USB,WLAN WIMAX POWER	S5_ON	S0-S3
5VSUS	+5V	23,39,43,48	SLP_S4# CTRLD POWER	SUSON	S0-S3
3VSUS	+3.3V	14,15,30,34,41,43,49	SLP_S4# CTRLD POWER	SUSON	S0-S3
1.5VSUS	+1.5V	4,6,14,15,43,45,46,49,50	SODIMM POWER	SUSON	S0-S3
0.75VSMDDR_VTERM	+0.75V	14,15,43,45	DDR3 SODIMM REFERENCE POWER	MAIN_ON	S0
+5V	+5V	12,18,23,24,25,26,28,35,37,41,43,44	SLP_S3# CTRLD POWER	MAIN_ON	S0
+3V	+3.3V	3,4,8,9,10,11,12,14,15,17,23,25,26,27,28,29,30,31,32,33,34,36,37,38,39,40,41,43,44,45,46,47,48,50,52	SLP_S3# CTRLD POWER	MAIN_ON	S0
+1.8V	+1.8V	6,12,17,18,21,22,33,43,50	LVDS,NVM POWER	MAIN_ON	S0
+1.5V	+1.5V	12,18,19,20,31,32,34,45,46	Mini PCIe,Express Card POWER	MAIN_ON	S0
+1.05V_VTT	+1.05V	4,6,11,12,43,46,48,52	AuBurndale VTT POWER	MAIN_ON	S0
+1.05V_PCH	+1.05V	3,10,12,43,46,52	PCH CORE POWER	1.05V_RUN_ON	S0
+VCC_GFX_CORE	+0.9V--+1.2V	18,21,43,49	VGA CORE POWER	GFXVR_EN	S0
VCC_CORE		6,43,48	CPU CORE POWER	VRON	S0
LCDVCC	+3.3V	23	LCD Power	ENVDD	S0
+5V_ODD	+5V	28	ODD Power	MAIN_ON	S0
+5V_HDD	+5V	28	HDD Power	MAIN_ON	S0
BAT-V	+10V--+17V	44	MAIN BATTERY	CHG_PBATT	S0-S5



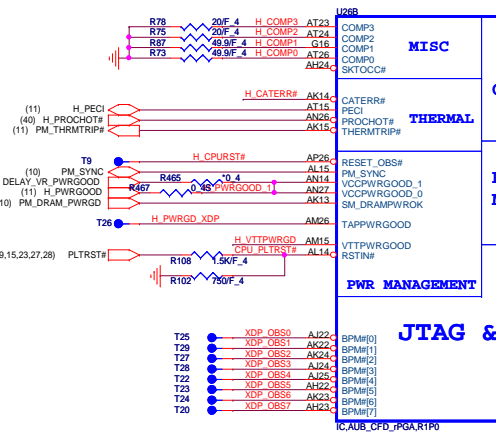
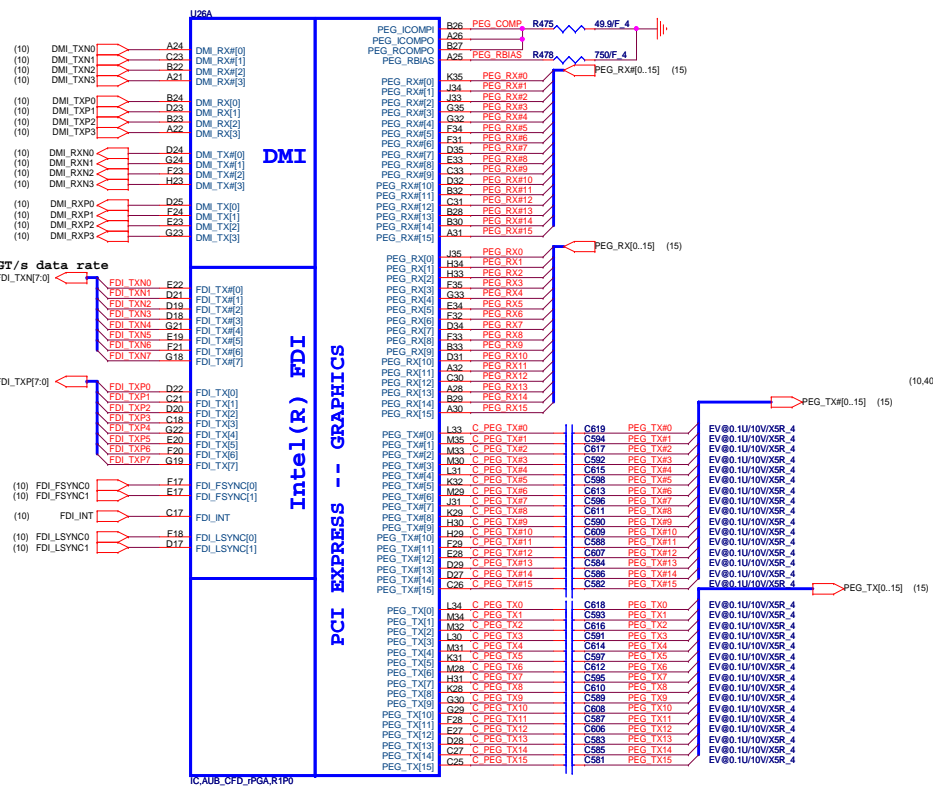

	DIS	UMA
Ra	NA	0 ohm
Rb	0 ohm	NA
Rc	0 ohm	NA

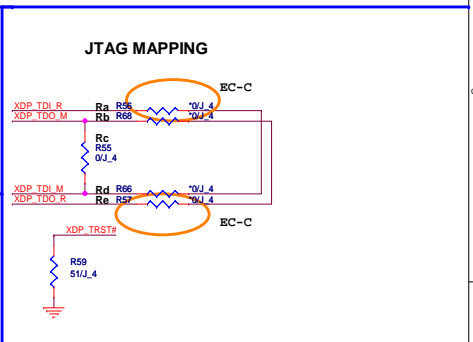
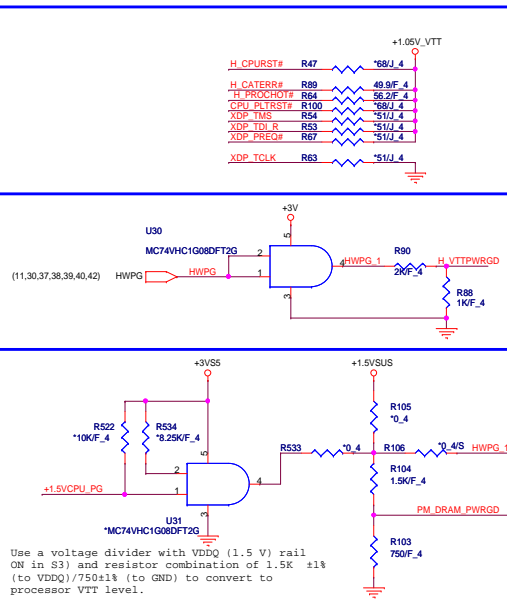
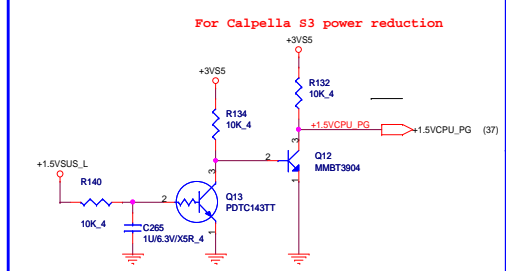
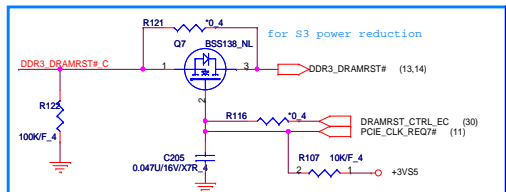
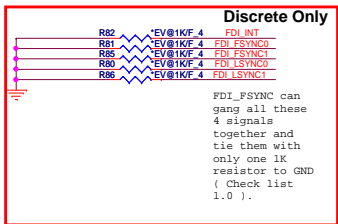
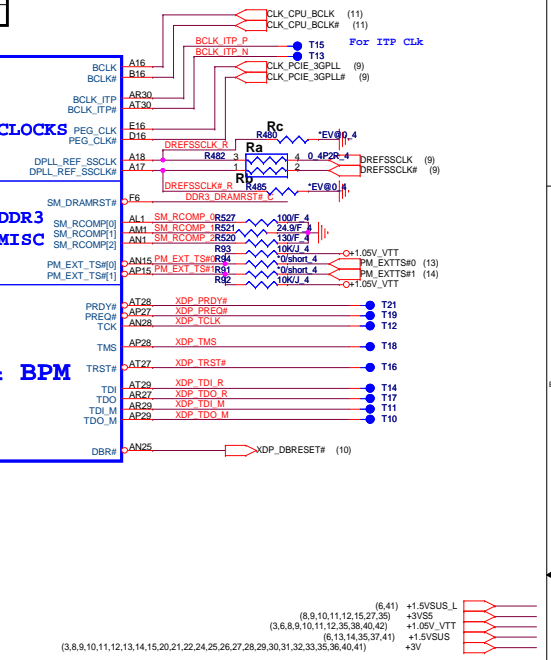

Scan Chain	STUFF ->
(Default)	Ra, Rc, Re NO STUFF -> Rb, Rd
CPU Only	Ra, Rb NO STUFF -> Rc, Rd, Re
GMCH Only	Rd, Re NO STUFF -> Ra, Rb, Rc

AUBURNDALE/CLARKSFIELD PROCESSOR (DDR3)

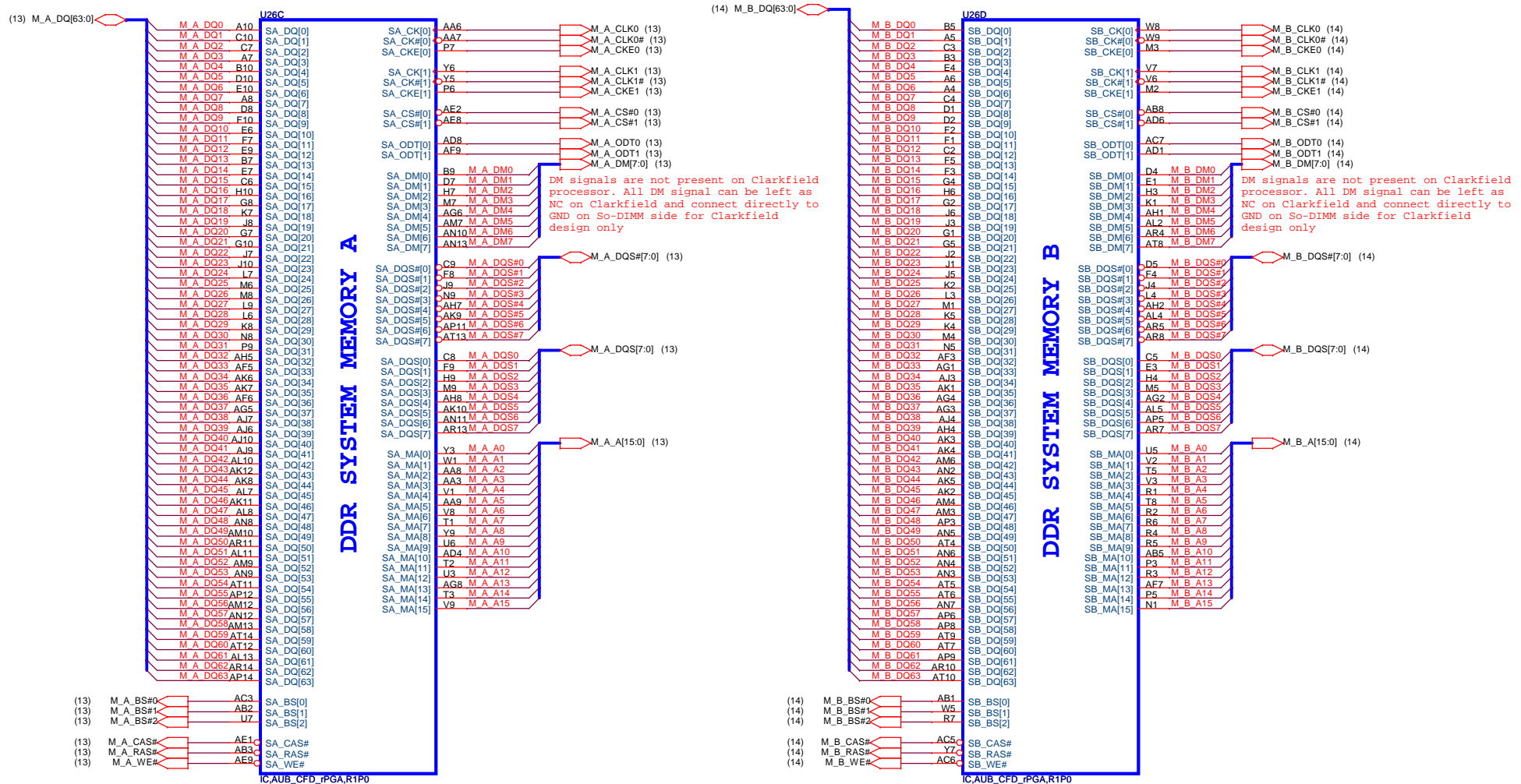

PROJECT : LL7A
Quanta Computer Inc.

Size: Custom Document Number: **PROCESSOR 2/4(DDR)** Rev: 1A

Date: Thursday, April 08, 2010 Sheet 5 of 42

	DIS	UMA
Rc	NA	4.7K
Rd	NA	0 ohm
Re	NA	0 ohm
Rf	NA	NA

C183	10UJ6.3V/XSR_8	AG35	VCC1
C145	10UJ6.3V/XSR_8	AG34	VCC2
C602	10UJ6.3V/XSR_8	AG32	VCC3
C141	10UJ6.3V/XSR_8	AG31	VCC4
C187	10UJ6.3V/XSR_8	AG29	VCC5
C164	10UJ6.3V/XSR_8	AG28	VCC6
C180	10UJ6.3V/XSR_8	AG26	VCC7
C192	10UJ6.3V/XSR_8	AG27	VCC8
C600	10UJ6.3V/XSR_8	AG26	VCC9
C177	10UJ6.3V/XSR_8	AF35	VCC10
C196	10UJ6.3V/XSR_8	AF34	VCC11
C605	10UJ6.3V/XSR_8	AF34	VCC12
C601	10UJ6.3V/XSR_8	AF32	VCC13
C167	10UJ6.3V/XSR_8	AF31	VCC14
C179	10UJ6.3V/XSR_8	AF29	VCC15
C580	10UJ6.3V/XSR_8	AF29	VCC16
C188	10UJ6.3V/XSR_8	AF28	VCC17
C189	10UJ6.3V/XSR_8	AF27	VCC18
C148	10UJ6.3V/XSR_8	AD36	VCC19
C186	10UJ6.3V/XSR_8	AD35	VCC20
C170	10UJ6.3V/XSR_8	AD34	VCC21
C604	10UJ6.3V/XSR_8	AD33	VCC22
C175	10UJ6.3V/XSR_8	AD32	VCC23
C603	10UJ6.3V/XSR_8	AD31	VCC24
C604	10UJ6.3V/XSR_8	AD30	VCC25
C178	10UJ6.3V/XSR_8	AD29	VCC26
C603	10UJ6.3V/XSR_8	AD28	VCC27
C191	10UJ6.3V/XSR_8	AD27	VCC28
C165	0.1U/10V/XSR_4	AD26	VCC29
C194	0.1U/10V/XSR_4	AC35	VCC30
C189	2	1	AC34
C192	2	1	AC32
C193	2	1	AC31
C194	2	1	AC30
C195	2	1	AC29
C196	2	1	AC28
C197	2	1	AC27
C198	2	1	AC26
C199	2	1	AC25
C200	2	1	AC24
C201	2	1	AC23
C202	2	1	AC22
C203	2	1	AC21
C204	2	1	AC20
C205	2	1	AC19
C206	2	1	AC18
C207	2	1	AC17
C208	2	1	AC16
C209	2	1	AC15
C210	2	1	AC14
C211	2	1	AC13
C212	2	1	AC12
C213	2	1	AC11
C214	2	1	AC10
C215	2	1	AC9
C216	2	1	AC8
C217	2	1	AC7
C218	2	1	AC6
C219	2	1	AC5
C220	2	1	AC4
C221	2	1	AC3
C222	2	1	AC2
C223	2	1	AC1

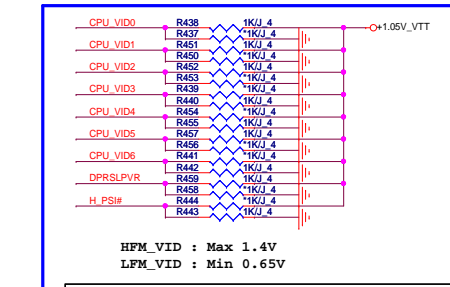
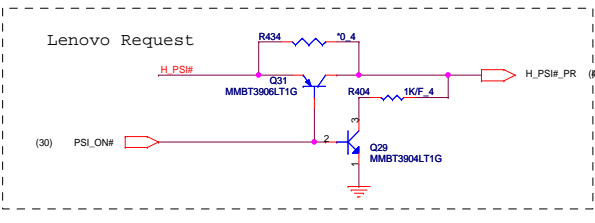
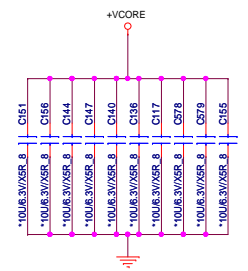
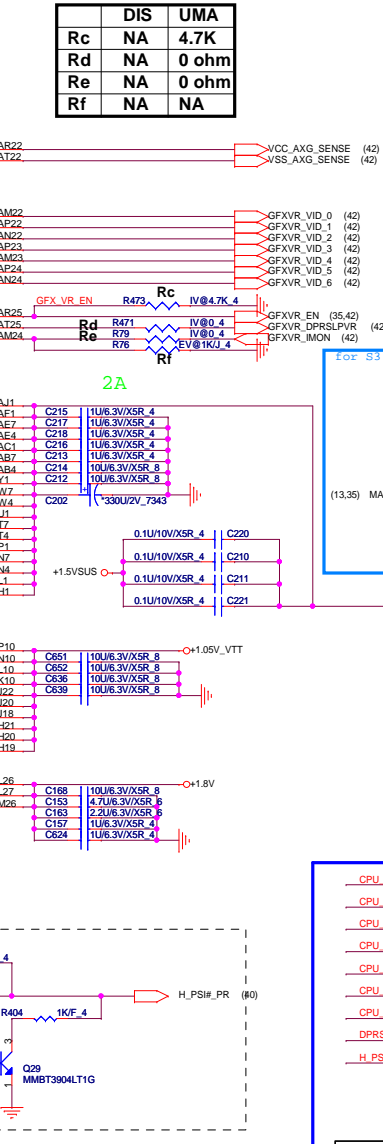
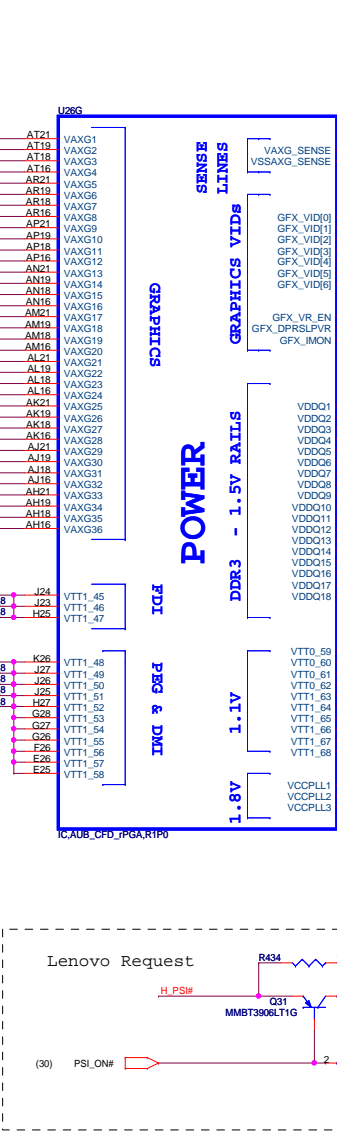
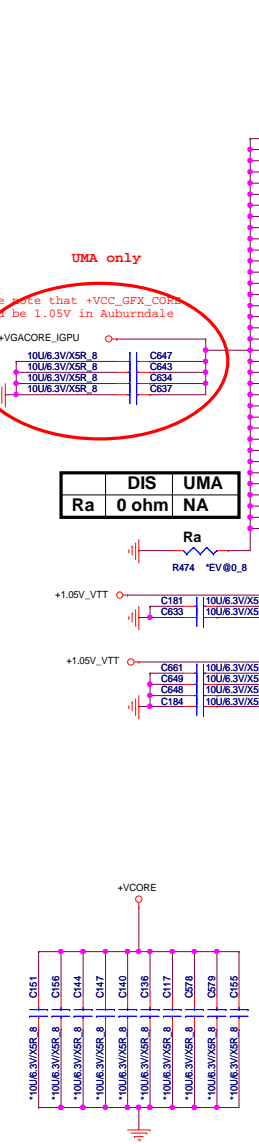
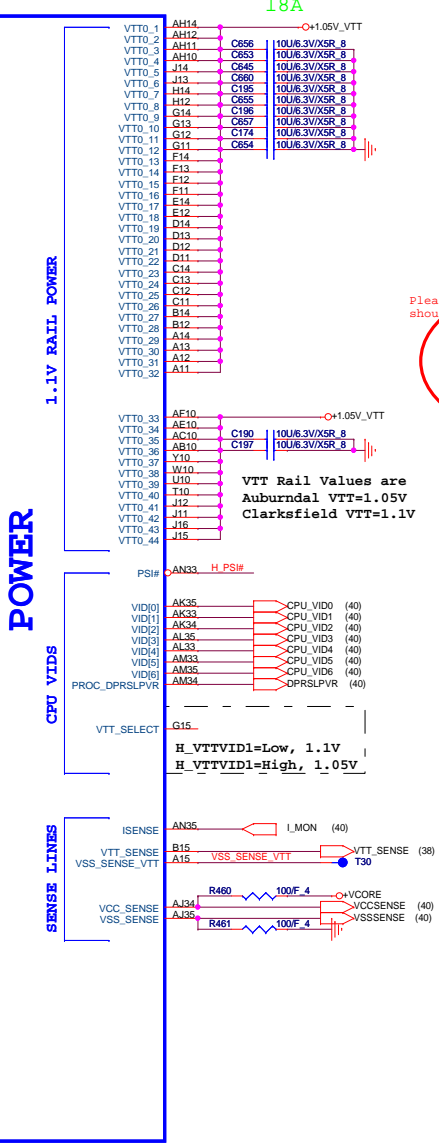

(35,42)	+VGCORE_IGPU
(3,4,8,9,10,11,12,35,38,40,42)	+VCCORE
(4,13,14,35,37,41)	+1.05V_VTT
(12,35,38,41)	+1.5VSUS
	+1.8V

PROJECT : LL7A

Quanta Computer Inc.

Size Custom Document Number **PROCESSOR 3/4(POWER)** Rev 1A

Date: Thursday, April 08, 2010 Sheet 6 of 42

AUBURNDALE/CLARKSFIELD PROCESSOR (GND)

AUBURNDALE/CLARKSFIELD PROCESSOR(RESERVED, CFG)

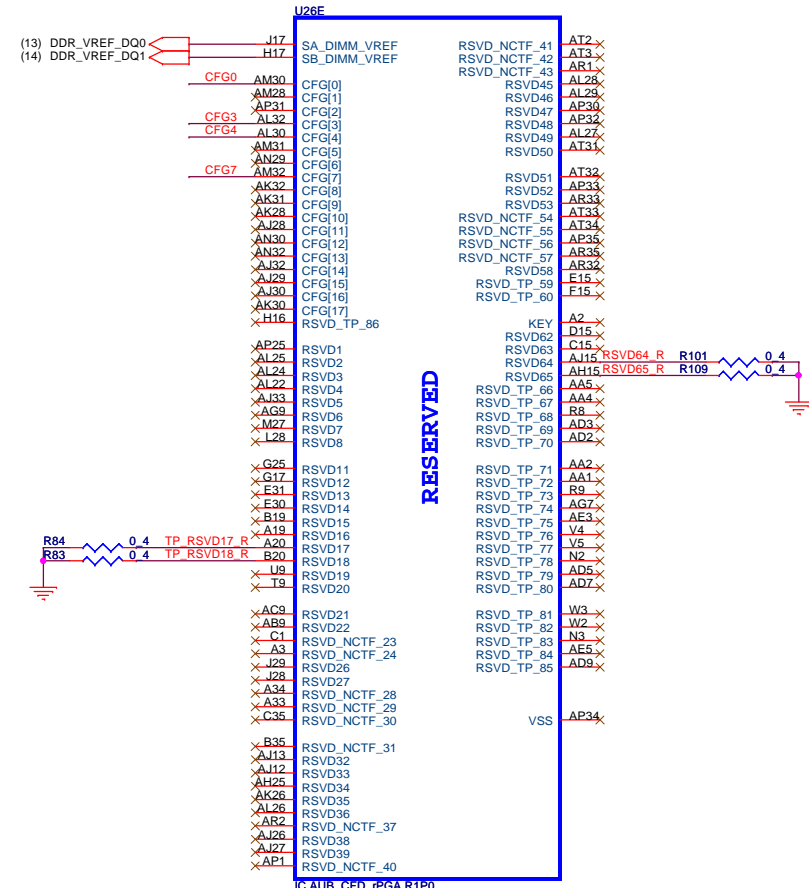
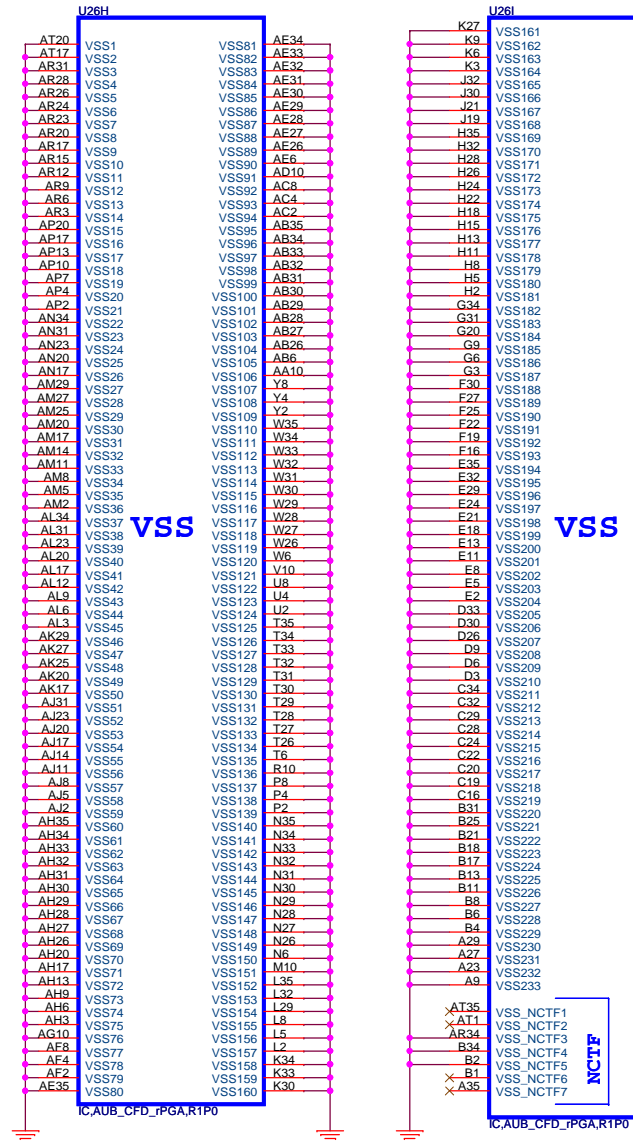

The Clarkfield processor's PCI Express interface may not meet PCI Express 2.0 jitter specifications. Intel recommends placing a 3.01K +/- 5% pull down resistor to VSS on CFG[7] pin for both rPGA and BGA components. This pull down resistor should be removed when this issue is fixed.

	1	0
CFG4 (Display Port Presence)	Disabled; No Physical Display Port attached to Embedded Display Port	Enabled; An external Display port device is connected to the Embedded Display port
CFG0 (PCI-Epress Configuration Select)	Single PEG	Bifurcation enabled
CFG3 (PCI-Epress Static Lane Reversal)	Normal Operation	Lane Numbers Reversed 15 -> 0, 14 -> 1

For Discrete only

CFG0 R52 ~3.01K NC
CFG3 R61 ~3.01K/F 4
CFG4 R80 ~3.01K NC
CFG7 R62 ~3.01K/F 4

CFG[1:0] - PCI_Epress Configuration Select
* 11= 1 x 16 PEG
* 10= 2 x 8 PEG

PROJECT : LL7A
Quanta Computer Inc.

Size: Custom Document Number: **PROCESSOR 4/4(GND)** Rev: 1A
Date: Thursday, April 08, 2010 Sheet 7 of 42

IBEX PEAK-M (HDA,JTAG,SATA)

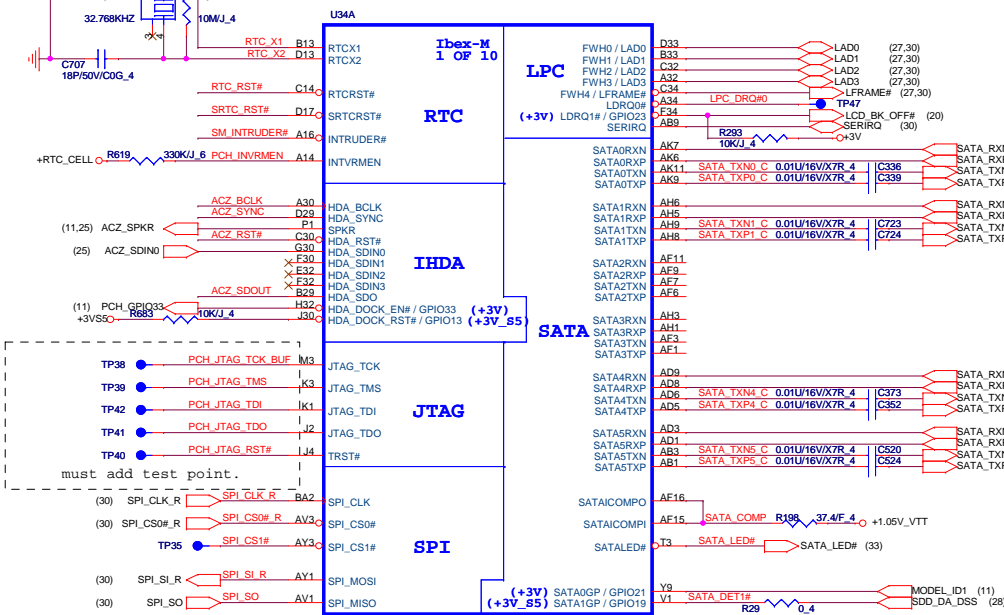

UMA CRT, LVDS&HDMI signals

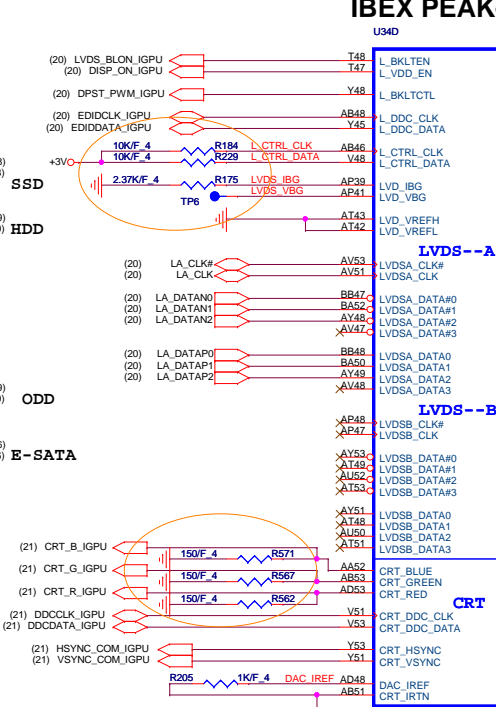

IBEX PEAK-M (LVDS,DDI)

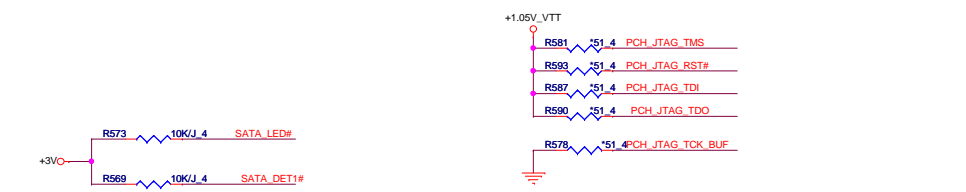
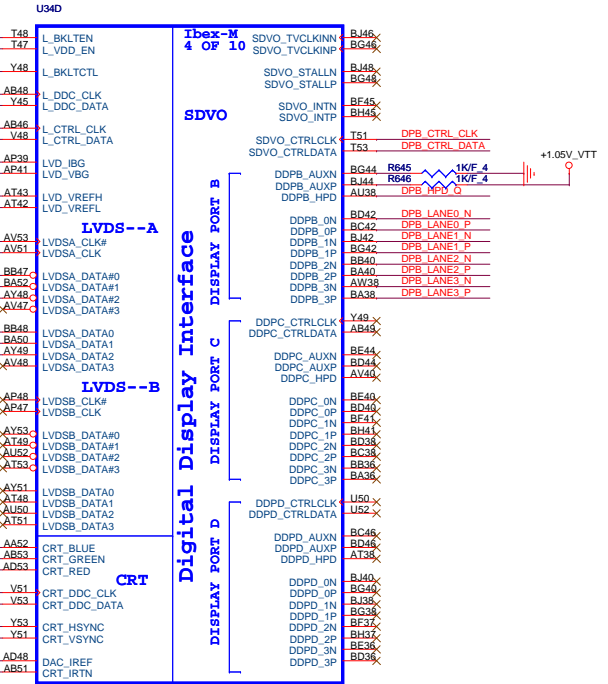

UMA HDMI signals

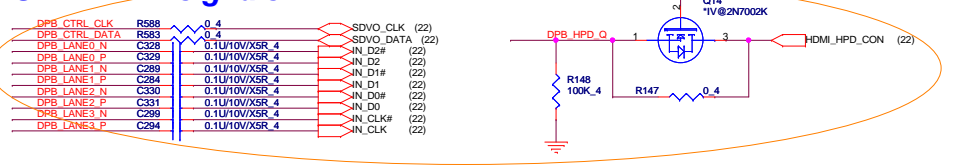

For AUDIO

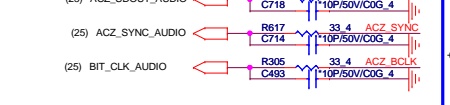

RTC 1mA

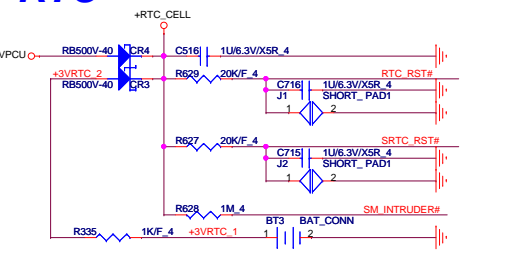

4M byte SPI ROM

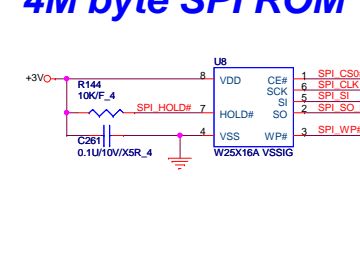

Vendor	PN
Socket	DG008000031
WINBOND	AKE39ZP0N00
MAX	AKE39FP0N00



IBEX PEAK-M (GND)

A77	VSS1(159)	VSS(259)	H49
B11	VSS(160)	VSS(260)	H5
B15	VSS(161)	VSS(261)	J24
B19	VSS(162)	VSS(262)	K11
B23	VSS(163)	VSS(263)	K43
B31	VSS(164)	VSS(264)	K47
B35	VSS(165)	VSS(265)	K7
B39	VSS(166)	VSS(266)	L14
B43	VSS(167)	VSS(267)	L18
B47	VSS(168)	VSS(268)	L2
B7	VSS(169)	VSS(269)	L22
BG12	VSS(170)	VSS(270)	L32
BB12	VSS(171)	VSS(271)	L36
BB16	VSS(172)	VSS(272)	L40
BB20	VSS(173)	VSS(273)	L52
BB24	VSS(174)	VSS(274)	M12
BB30	VSS(175)	VSS(275)	M16
BB34	VSS(176)	VSS(276)	M20
BB38	VSS(177)	VSS(277)	N38
BB42	VSS(178)	VSS(278)	M38
BB49	VSS(179)	VSS(279)	M42
BB5	VSS(180)	VSS(280)	M46
BC10	VSS(181)	VSS(281)	M49
BC14	VSS(182)	VSS(282)	M5
BC18	VSS(183)	VSS(283)	M8
BC2	VSS(184)	VSS(284)	M9
BC22	VSS(185)	VSS(285)	N24
BC32	VSS(186)	VSS(286)	P11
BC36	VSS(187)	VSS(287)	AD15
BC40	VSS(188)	VSS(288)	P22
RC44	VSS(189)	VSS(289)	P30
RC52	VSS(190)	VSS(290)	P32
BH9	VSS(191)	VSS(291)	P34
BD48	VSS(192)	VSS(292)	P42
BD49	VSS(193)	VSS(293)	P45
BD5	VSS(194)	VSS(294)	P47
BE12	VSS(195)	VSS(295)	R2
BE16	VSS(196)	VSS(296)	R52
BE20	VSS(197)	VSS(297)	T14
BE30	VSS(198)	VSS(298)	T46
BE34	VSS(199)	VSS(299)	T49
BE38	VSS(201)	VSS(301)	T5
BE42	VSS(202)	VSS(302)	T8
BE46	VSS(203)	VSS(303)	T30
BE48	VSS(204)	VSS(304)	U31
BE50	VSS(205)	VSS(305)	U32
BE6	VSS(206)	VSS(306)	U34
BE8	VSS(207)	VSS(307)	P38
BE49	VSS(208)	VSS(308)	V11
BF51	VSS(209)	VSS(309)	V19
BG18	VSS(210)	VSS(310)	V20
BG24	VSS(211)	VSS(311)	V22
BG4	VSS(212)	VSS(312)	V30
BG50	VSS(213)	VSS(313)	V32
BH11	VSS(214)	VSS(314)	V34
BH15	VSS(215)	VSS(315)	V35
BH19	VSS(216)	VSS(316)	V37
BH23	VSS(217)	VSS(317)	V38
BH31	VSS(218)	VSS(318)	V43
BH35	VSS(219)	VSS(319)	V45
BH39	VSS(220)	VSS(320)	V46
BH43	VSS(221)	VSS(321)	V47
BH47	VSS(222)	VSS(322)	V49
BH7	VSS(223)	VSS(323)	V5
C12	VSS(224)	VSS(324)	V7
C50	VSS(225)	VSS(325)	V8
D51	VSS(226)	VSS(326)	W2
E16	VSS(227)	VSS(327)	W52
E20	VSS(228)	VSS(328)	Y11
E24	VSS(229)	VSS(329)	Y12
E30	VSS(230)	VSS(330)	Y15
E34	VSS(231)	VSS(331)	Y16
E38	VSS(232)	VSS(332)	Y19
E42	VSS(233)	VSS(333)	Y28
E46	VSS(234)	VSS(334)	Y30
E48	VSS(235)	VSS(335)	Y31
F4	VSS(236)	VSS(336)	Y32
F6	VSS(237)	VSS(337)	Y38
F8	VSS(238)	VSS(338)	Y43
F49	VSS(239)	VSS(339)	Y46
F5	VSS(240)	VSS(340)	P49
G10	VSS(241)	VSS(341)	Y5
G14	VSS(242)	VSS(342)	Y6
G18	VSS(243)	VSS(343)	Y8
G2	VSS(244)	VSS(344)	Y8
G22	VSS(245)	VSS(345)	I43
G32	VSS(246)	VSS(346)	AD51
G36	VSS(247)	VSS(347)	AT8
G40	VSS(248)	VSS(348)	AD47
G44	VSS(249)	VSS(349)	Y47
G52	VSS(250)	VSS(350)	AT12
AF39	VSS(251)	VSS(351)	AM6
H16	VSS(252)	VSS(352)	AT13
H20	VSS(253)	VSS(353)	AM5
H30	VSS(254)	VSS(354)	AK45
H34	VSS(255)	VSS(355)	AK39
H38	VSS(256)	VSS(356)	AV14
H42	VSS(257)	VSS(357)	
H42	VSS(258)	VSS(358)	

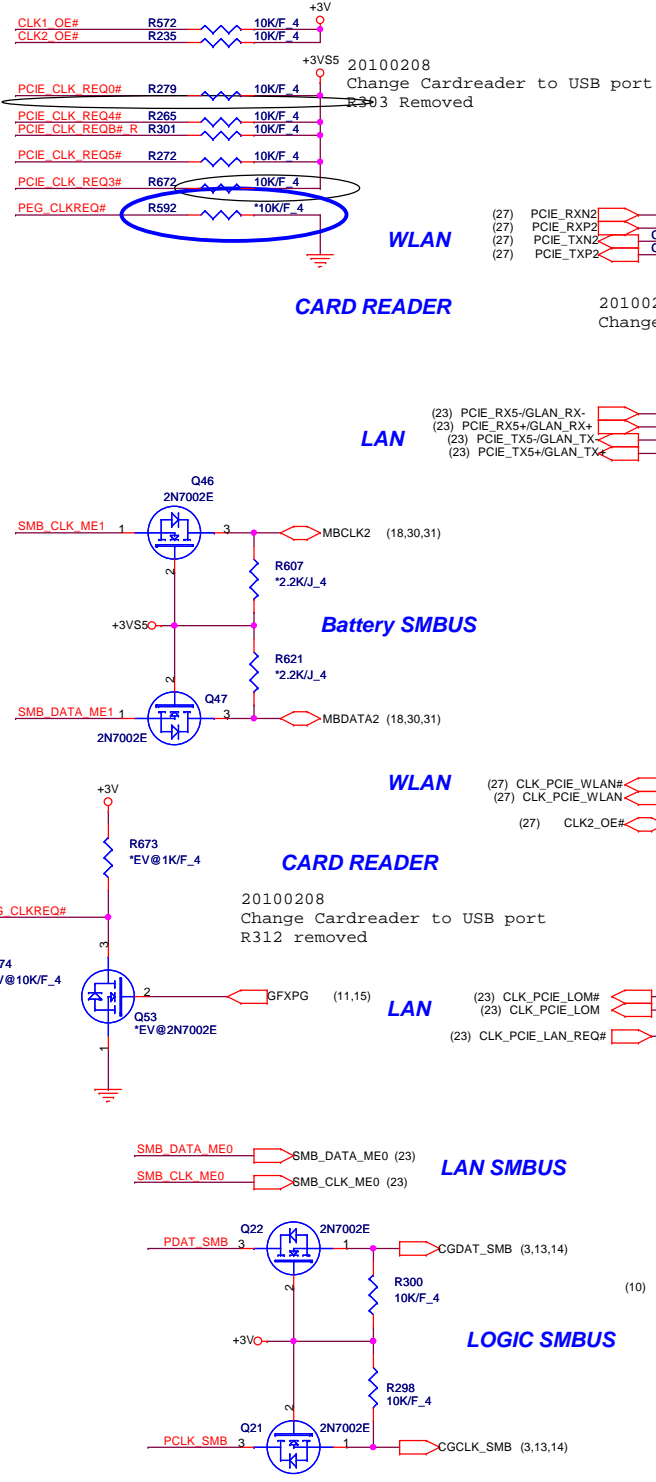

IBEX PEAK-M (PCI-E, SMBUS, CLK)

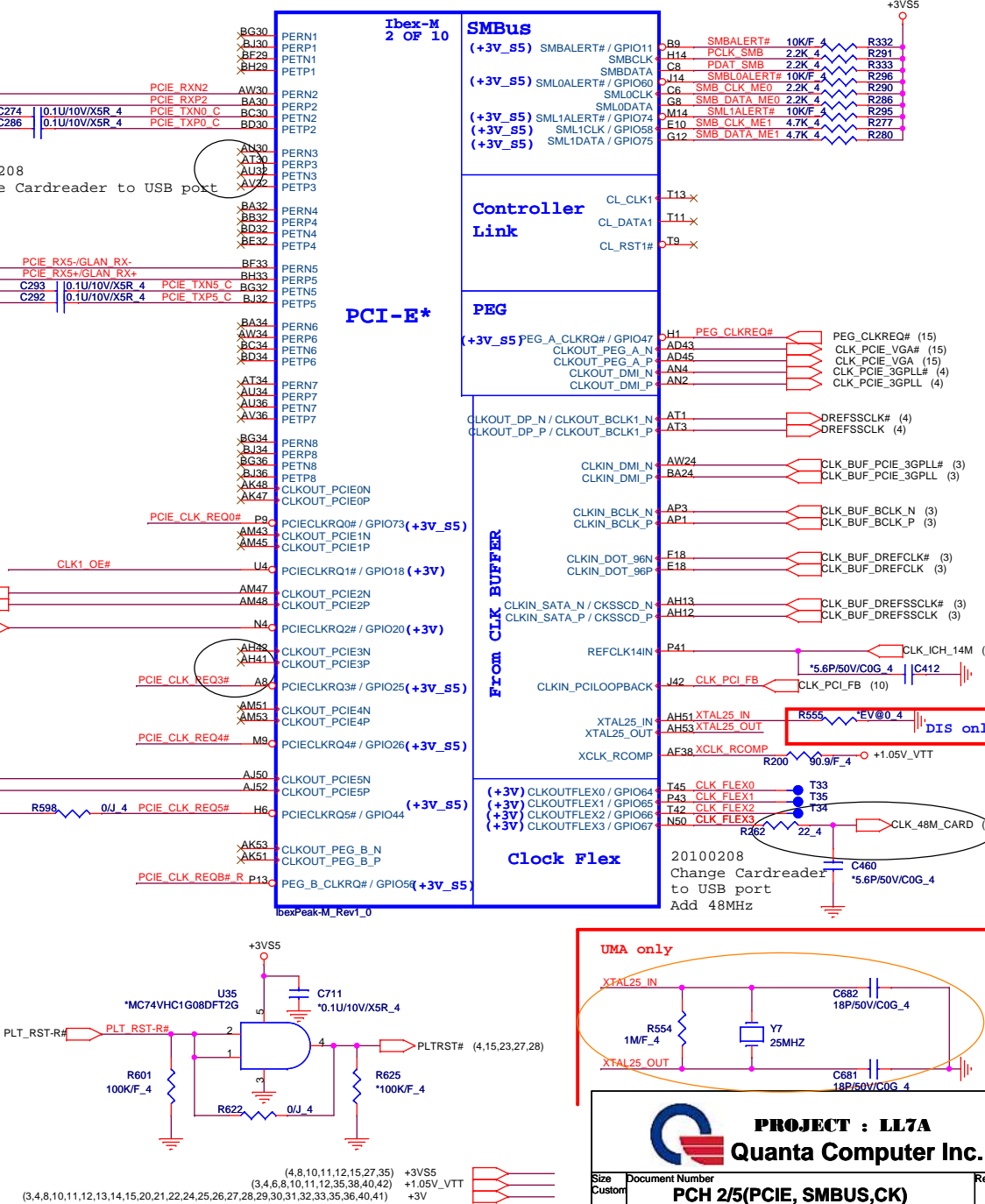

PROJECT : LL7A
Quanta Computer Inc.

Size: 4.8,10,11,12,15,27,35 +3V55
 Custom: (3,4,6,8,10,11,12,35,38,40,42) +1.05V_VTT
 Date: Thursday, April 08, 2010 Sheet 9 of 42

UMA only

Clock Flex

(4,8,10,11,12,15,27,35) +3V55
 (3,4,6,8,10,11,12,35,38,40,42) +1.05V_VTT
 (3,4,8,10,11,12,13,14,15,20,21,22,24,25,26,27,28,29,30,31,32,33,35,36,40,41) +3V

IBEX PEAK-M (DMI,FDI,GPIO)

IBEX PEAK-M (PCI,USB,NVRAM)

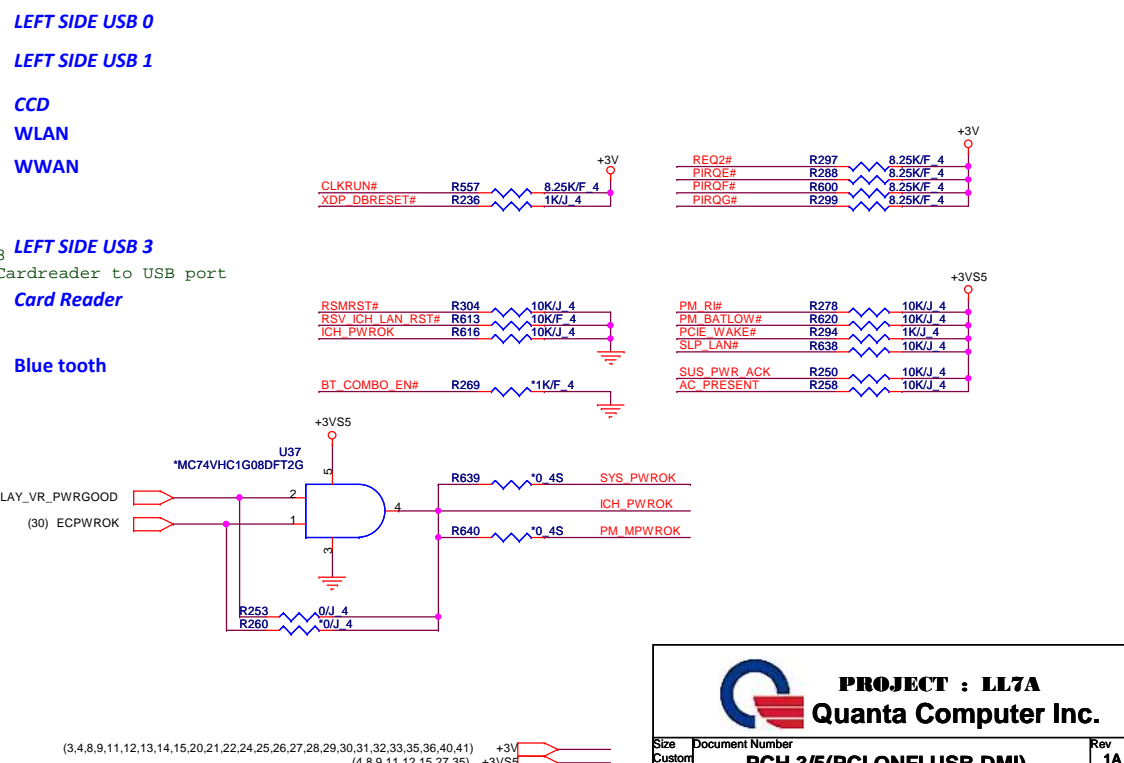
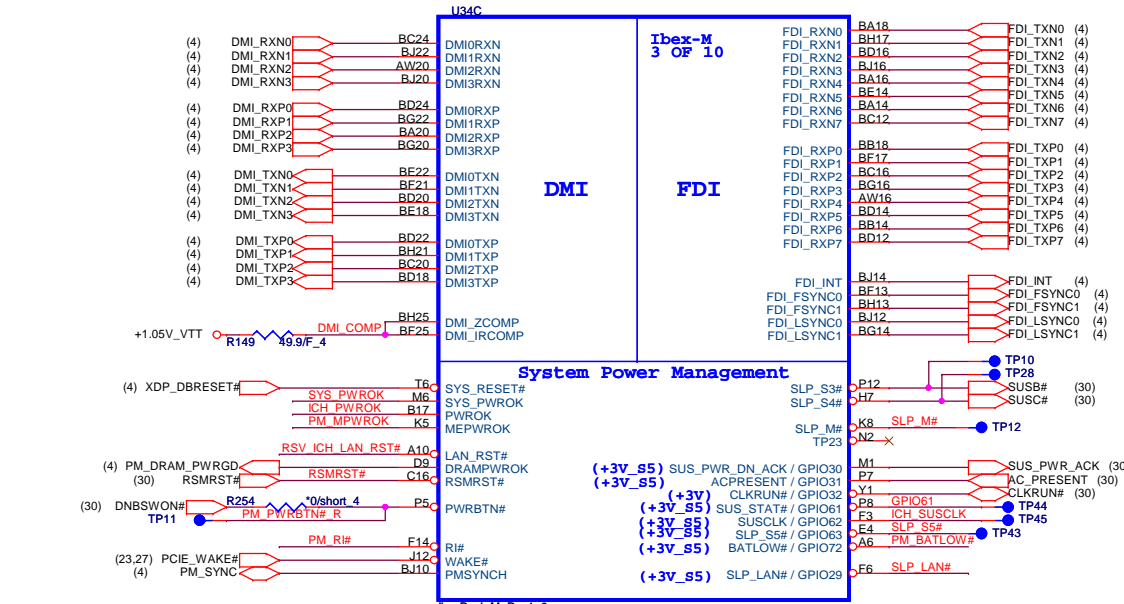
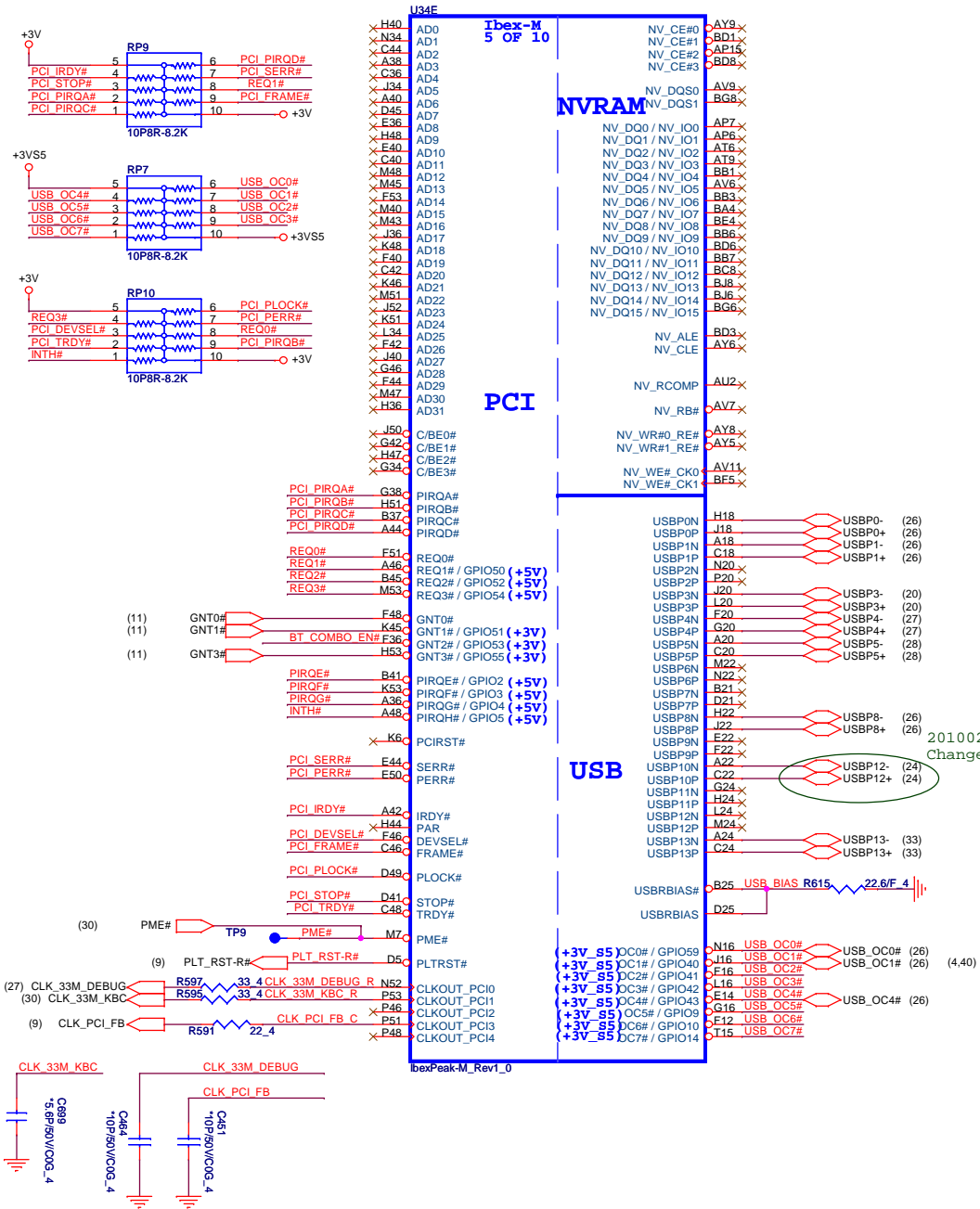

IBEX PEAK-M (GPIO,VSS_NCTF,RSVD)

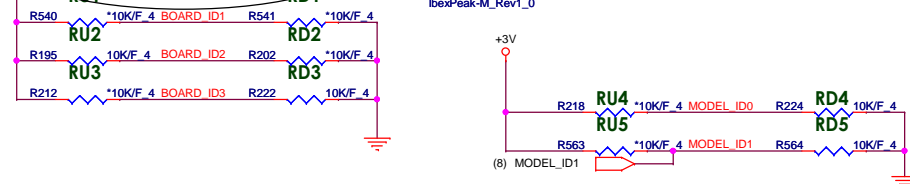
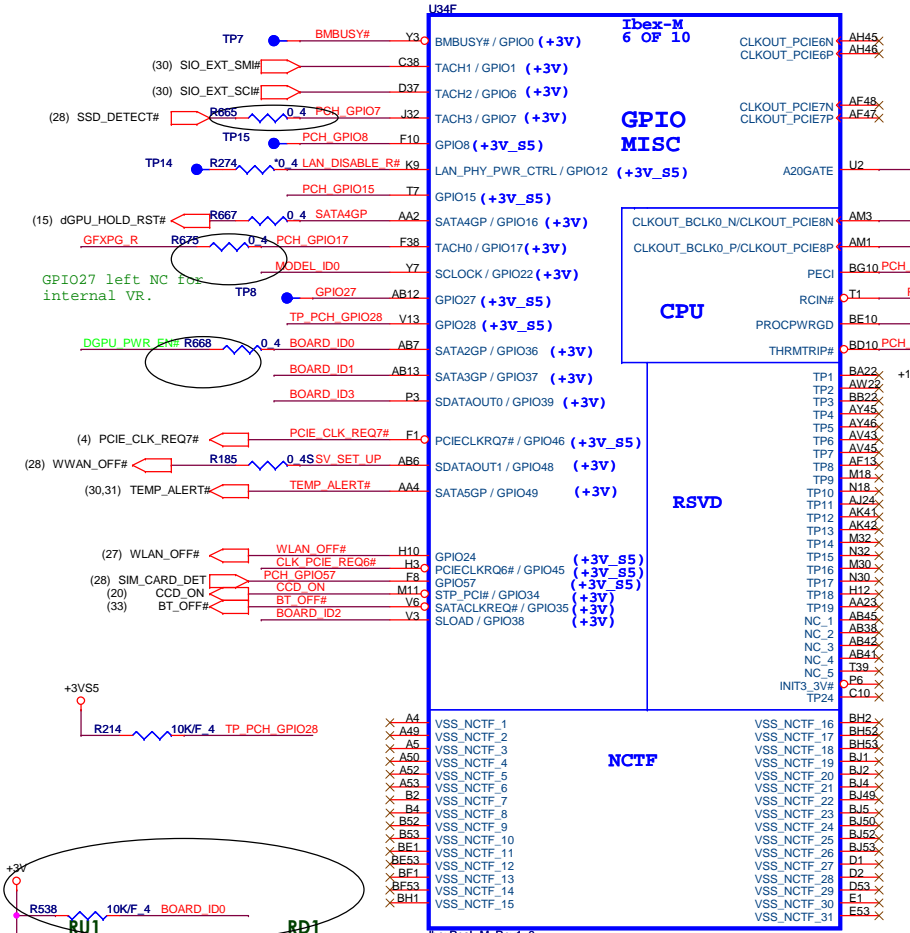

Board ID For Function	ID1 GPIO37	ID2 GPIO38	ID3 GPIO39
SDV	0	0	0
SIV	0	0	0
SIT	0	1	0
SVT	1	0	0
SOVP	0	1	0

Model ID	MODEL_ID0	MODEL_ID1
Default	0	0
LL7	0	1
LL7A	1	0

IBEX PEAK-M (GND)

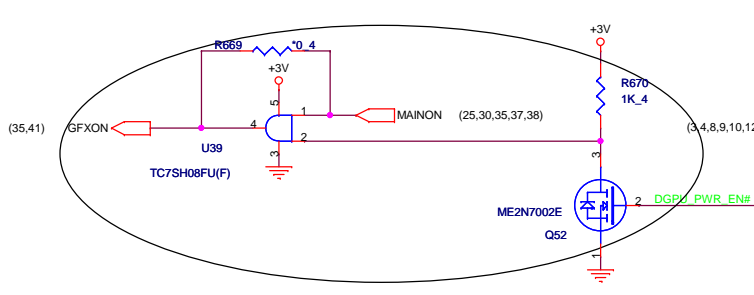
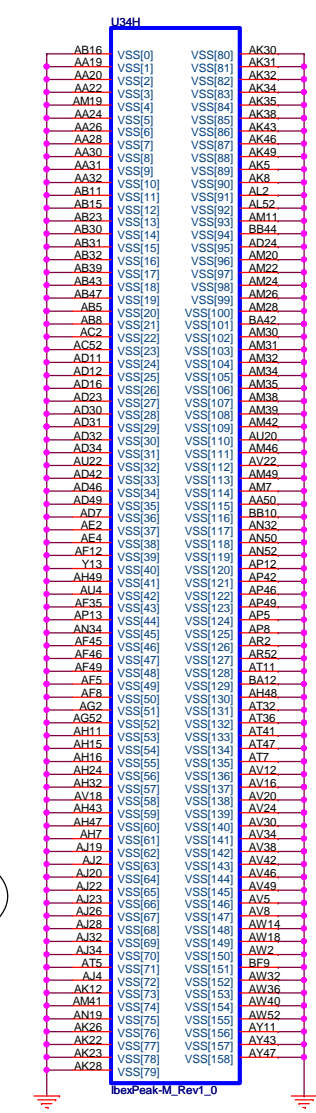

(10) GNT3# R609 *10K_NC

A16 swap override Strap/Top-Block Swap Override jumper

GNT3#	Low = A16 swap override/Top-Block Swap Override enabled High = Default
-------	---

(10) GNT0# R266 *1K/F 4

(10) GNT1# R606 *1K/F 4

Boot BIOS Strap

PCI_GNT0#	GNT#1	Boot BIOS Location
0	0	LPC
0	1	Reserved (NAND)
1	0	PCI
1	1	SPI

SV_SET_UP R196 10K/F 4 +3V

SV_SET_UP	1-X High = Strong (Default)
-----------	-----------------------------

Danbury Technology Enabled

NV_ALE	High = Enable Low = Disable
--------	--------------------------------

DMI Termination Voltage

NV_CLE	Set to Vcc when LOW Set to Vcc/2 when HIGH
--------	---

No Reboot Strap

(8,25) ACZ_SPKR *1K/F 4 R580 +3V

(8) PCH_GPIO33 R264 *100K/F 4

(3,4,6,8,9,10,12,35,38,40,42) +1.05V_VTT

(4,8,9,10,12,13,14,15,20,21,22,24,25,26,27,28,29,30,31,32,33,35,36,40,41) +3V

(4,8,9,10,12,15,27,35) +3VSS

PROJECT : LL7A

Quanta Computer Inc.

Size	Document Number	PCH 4/5(GPIO & STRAP)	Rev
Custom			1A
Date: Thursday, April 08, 2010		Sheet 11	of 42

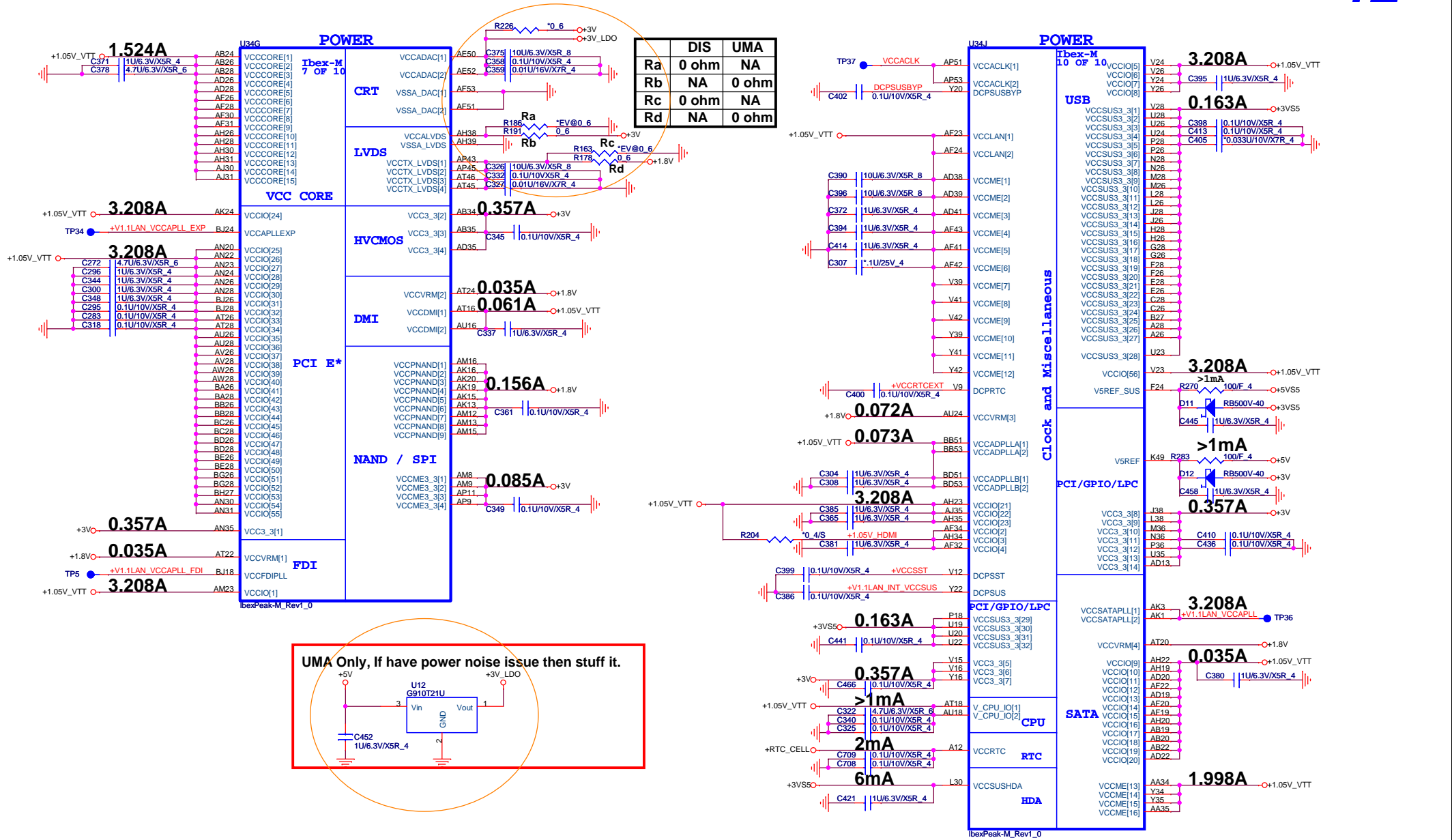

	DIS	UMA
Ra	0 ohm	NA
Rb	NA	0 ohm
Rc	0 ohm	NA
Rd	NA	0 ohm

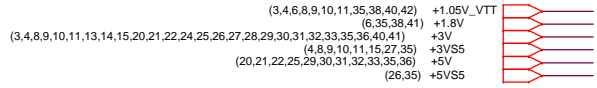
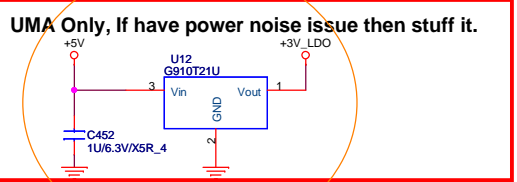

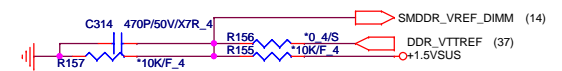
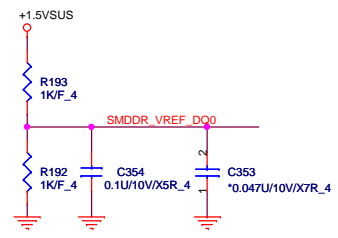
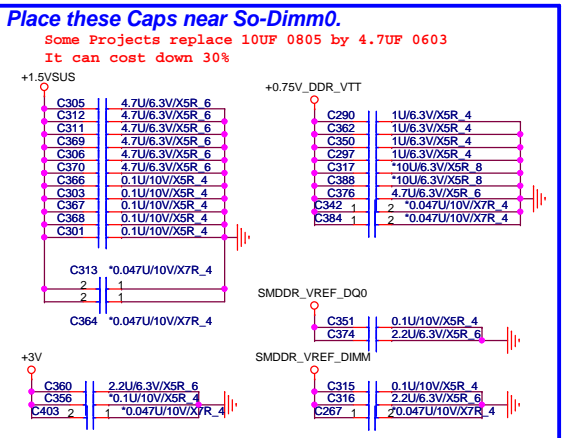
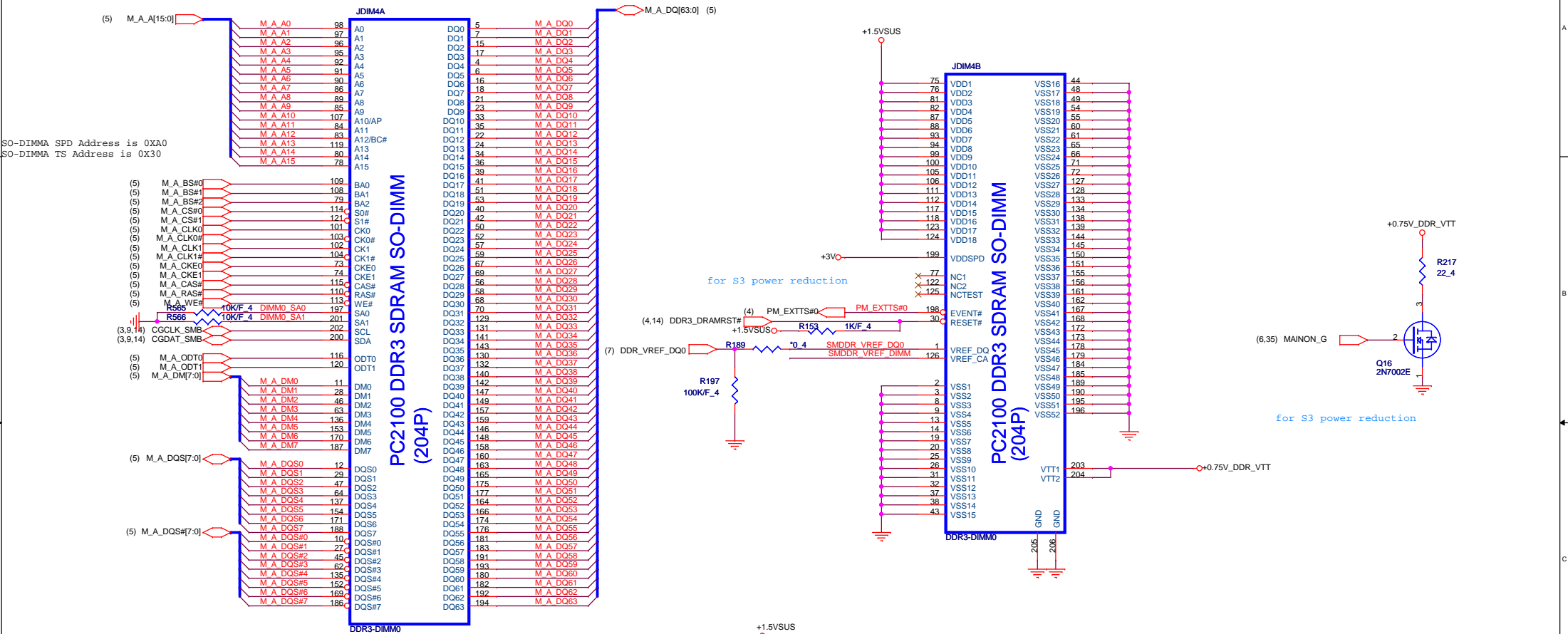

PROJECT : LL7A
Quanta Computer Inc.

Size	Document Number	Rev
Custom	DDR3 DIMM-0	1A
Date:	Thursday, April 08, 2010	Sheet 13 of 42

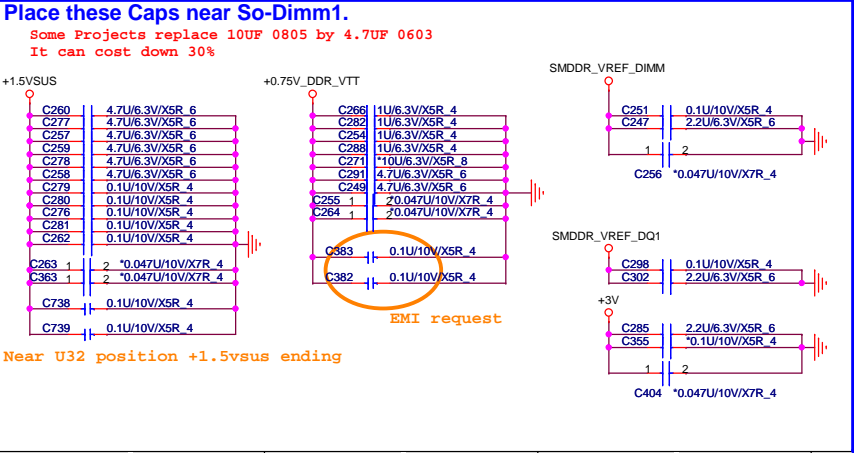
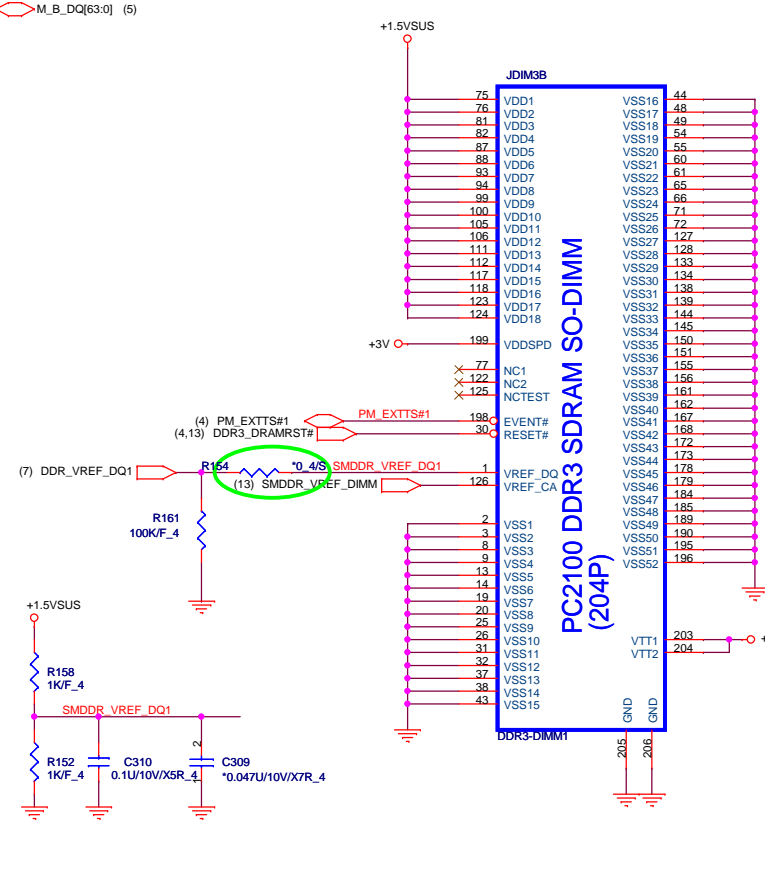
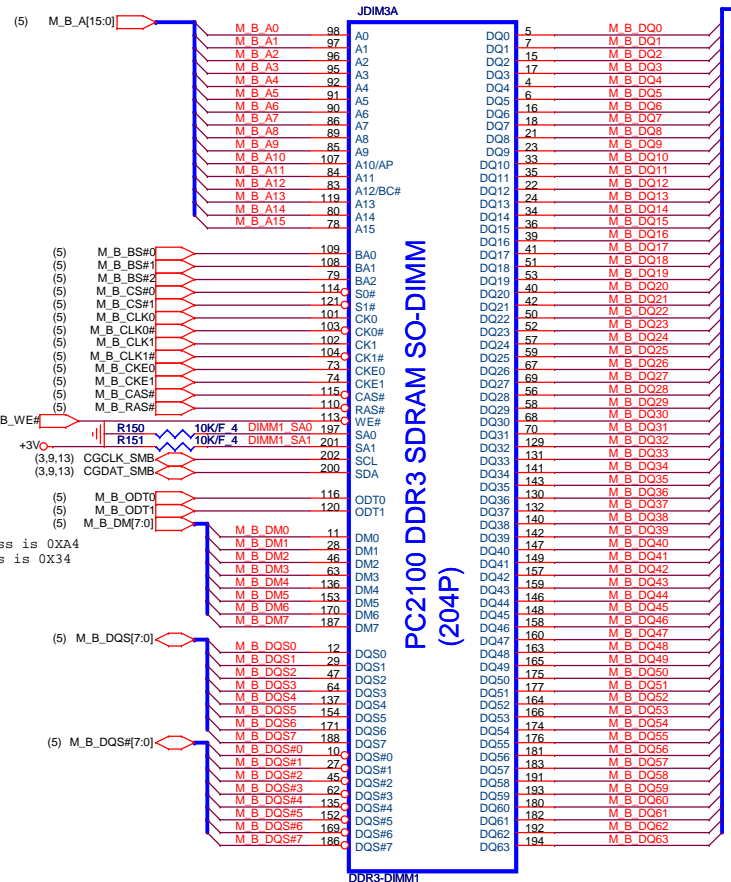
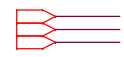

PROJECT : LL7A
Quanta Computer Inc.

Size	Document Number	Rev
Customer	DDR3 DIMM-1	1A
Date:	Thursday, April 08, 2010	Sheet 14 of 42

power up sequence 15

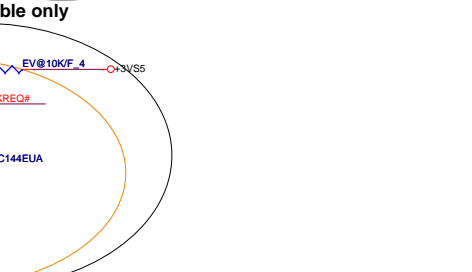
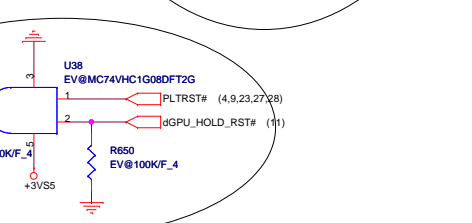
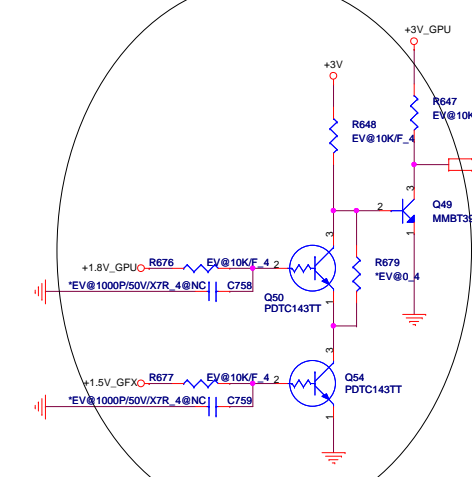
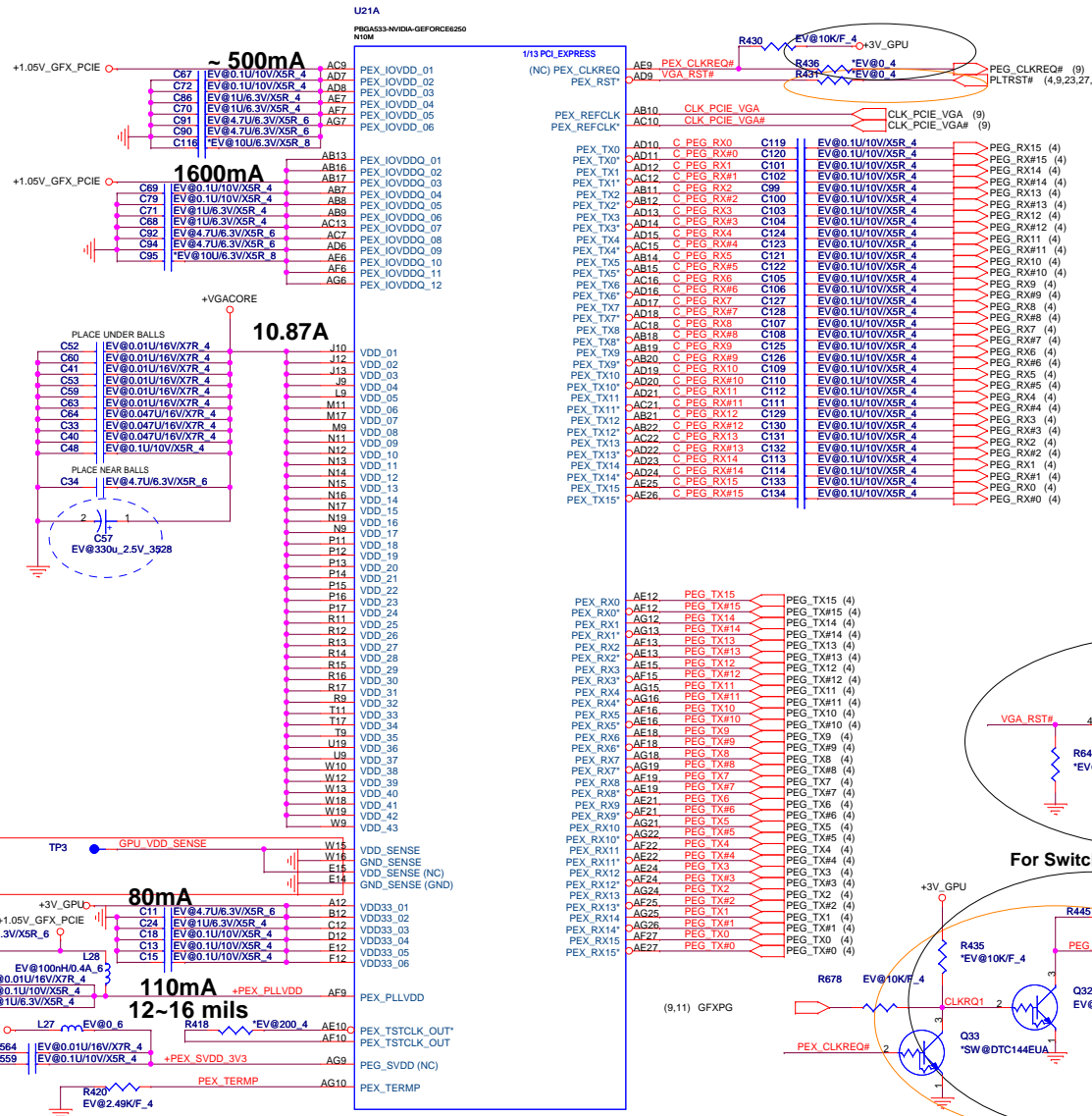
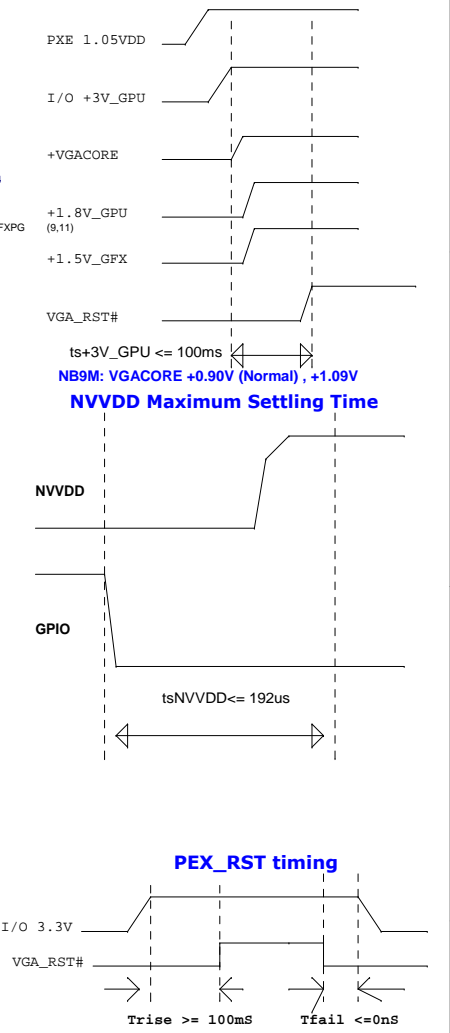

- (3,4,8,9,10,11,12,13,14,20,21,22,24,25,26,27,28,29,30,31,32,33,35,36,40,41) +3V
- (16,17,35,41) +1.05V_GFX_PCIE
- (4,8,9,10,11,12,27,35) +3VSS
- (35,41) +VGACORE

PROJECT : LL7A
Quanta Computer Inc.

Size	Document Number	Rev
Custom	N11M(PCIE I/F) 1/5	1A
Date:	Thursday, April 08, 2010	Sheet 15 of 42

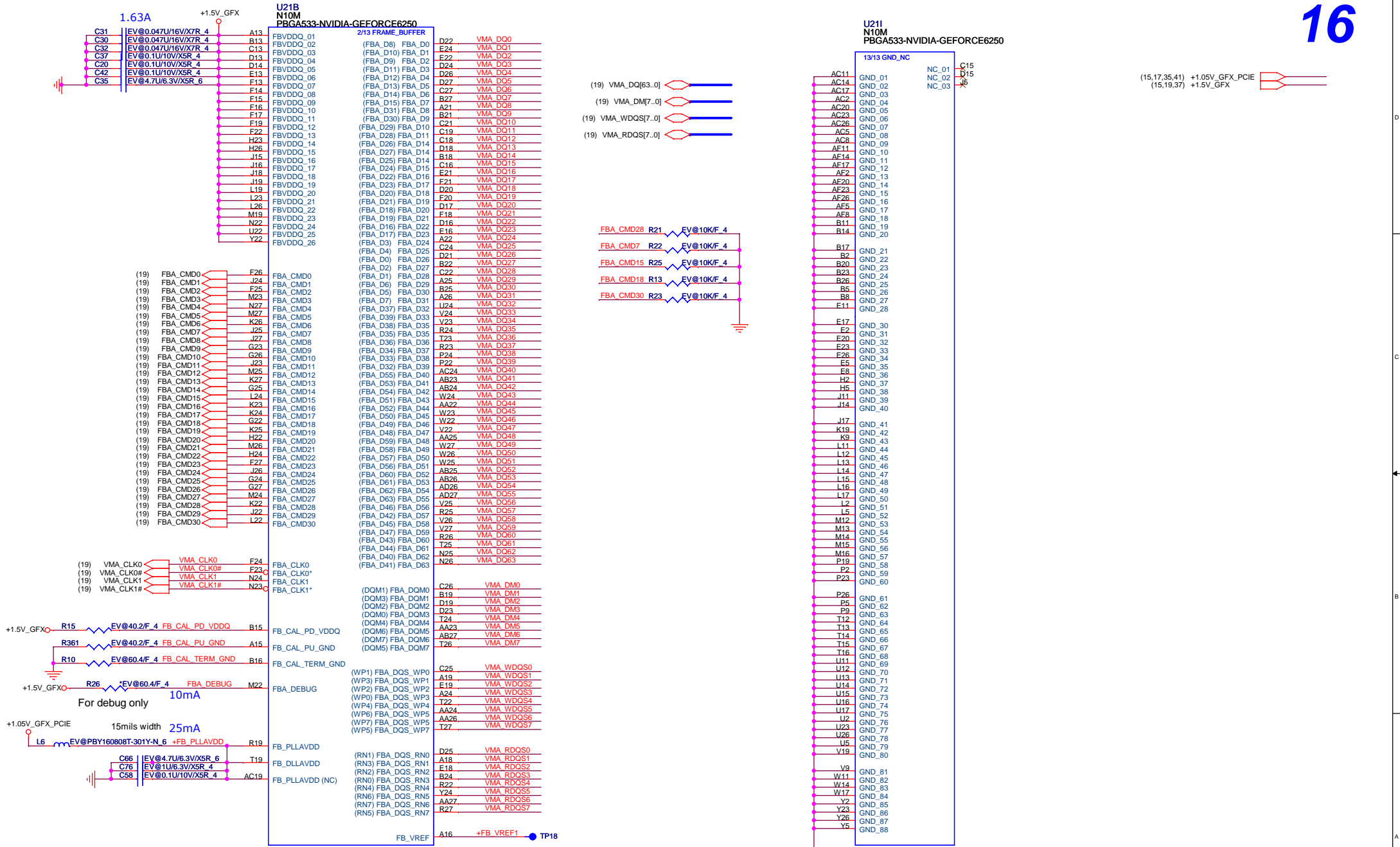

PROJECT : LL7A
Quanta Computer Inc.

Size Custom	Document Number N11M(MEMORY I/F & GND) 2/5	Rev 1A
Date: Thursday, April 08, 2010	Sheet 16	of 42

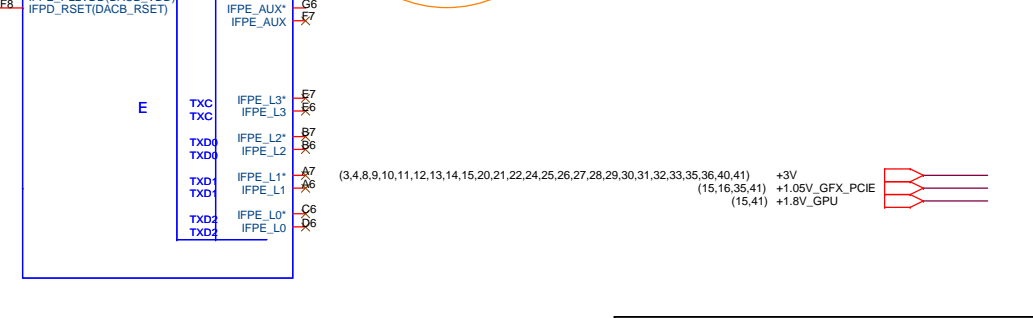
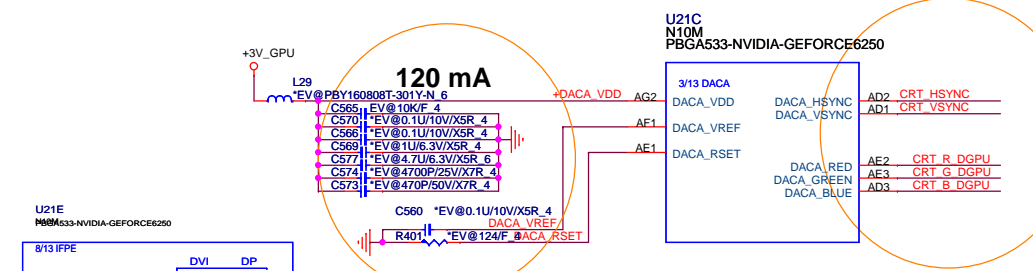
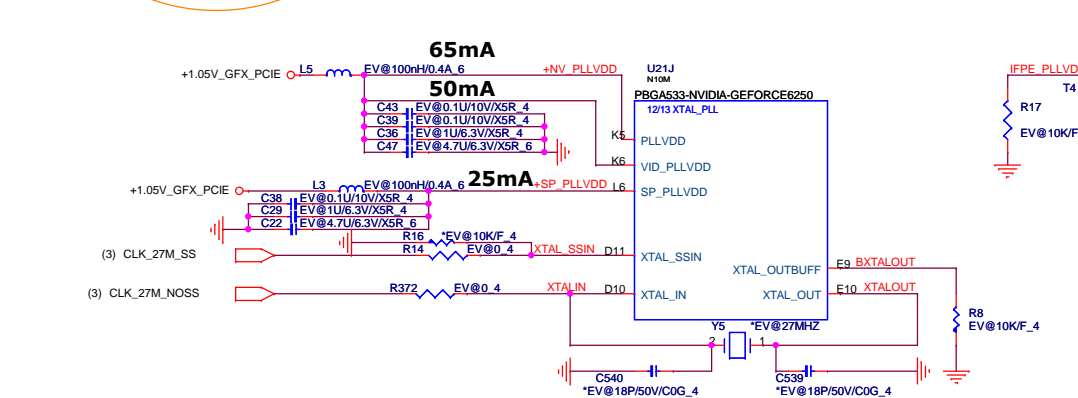
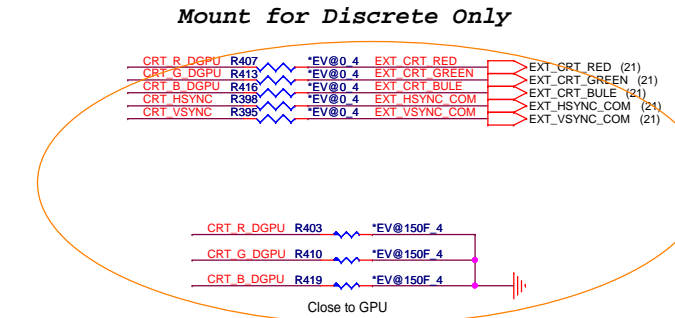
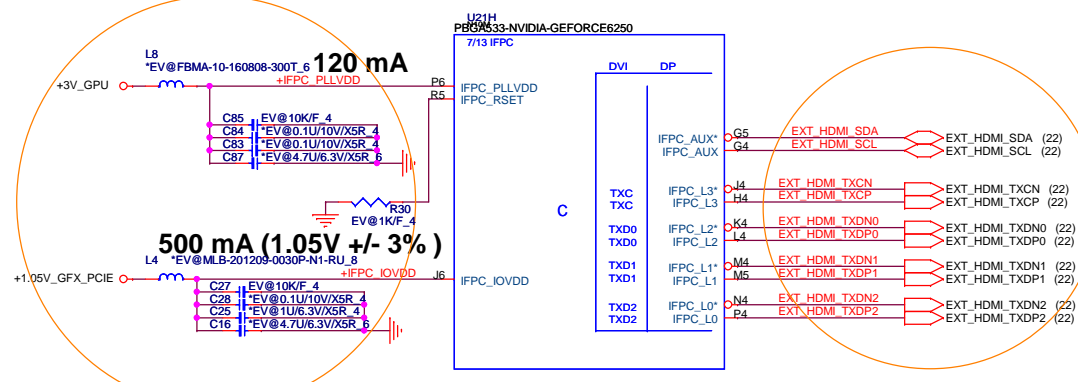
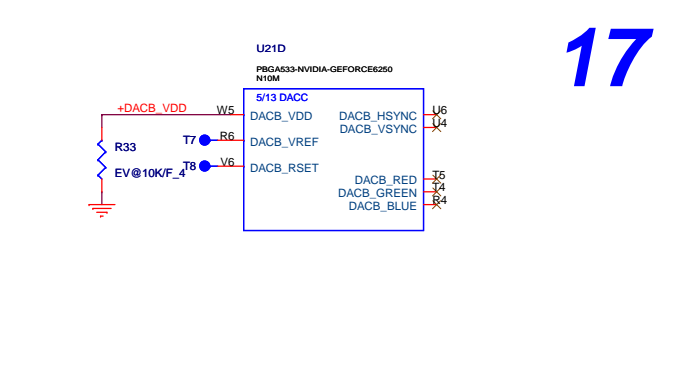
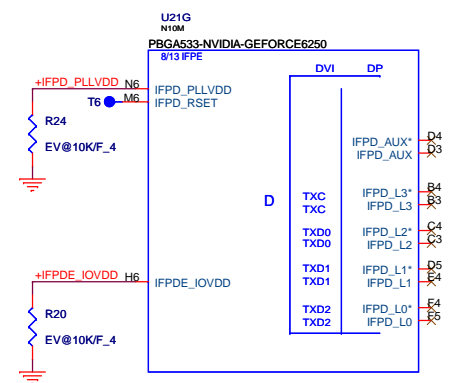
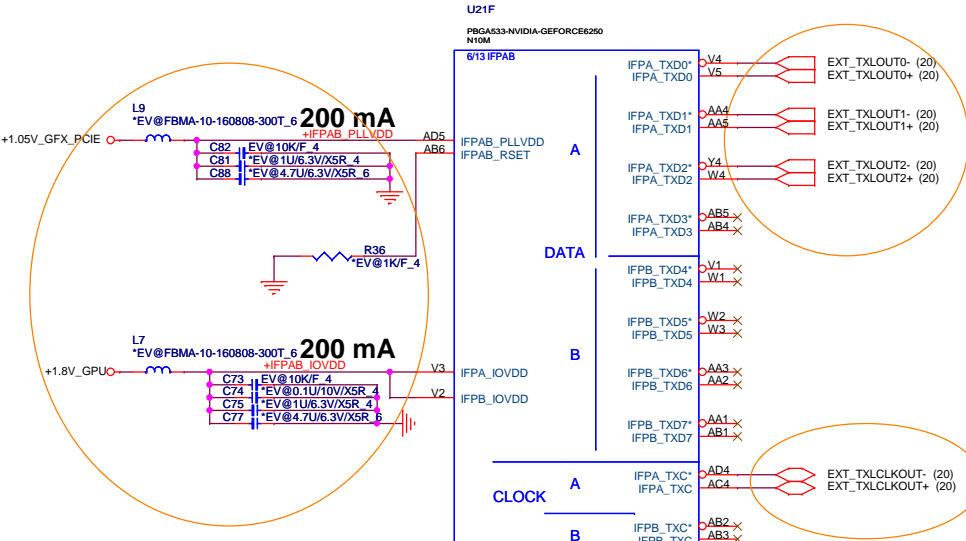

STUFF PDs on XTALSSIN and XTALOUTBUFF WHEN EXT_SS Install it when not connected to Spread spectrum device

(3,4,8,9,10,11,12,13,14,15,20,21,22,24,25,26,27,28,29,30,31,32,33,35,36,40,41) +3V (15,16,35,41) +1.05V_GFX_PCIE (15,41) +1.8V_GPU

PROJECT : LL7A
Quanta Computer Inc.

Size: Custom Document Number: **N11M(DISPLAY) 3/5** Rev: 1A

Date: Thursday, April 08, 2010 Sheet 17 of 42

SEE Datasheet for details on N10P Straps!

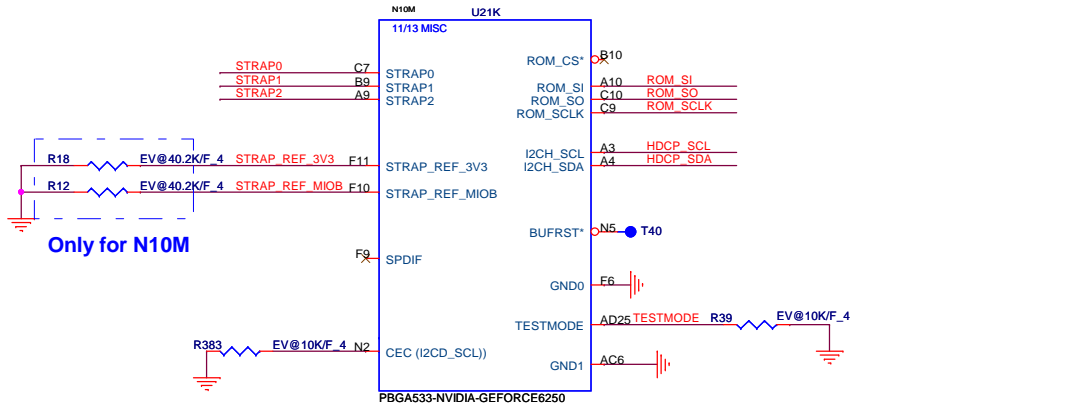

Only for N10M

	PU-VDD	PD
5K	1000	0000
10K	1001	0001
15K	1010	0010
20K	1011	0011
25K	1100	0100
30K	1101	0101
35K	1110	0110
45K	1111	0111

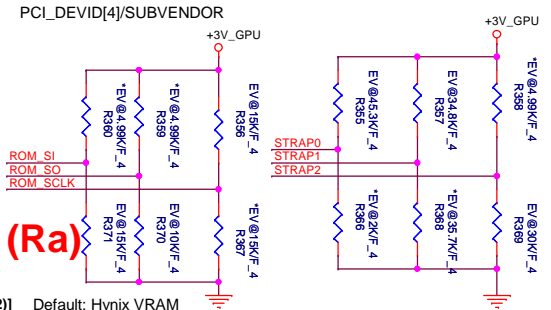

4.99K/F 4: CS24992FB26 [RES CHIP 4.99K 1/16W +1%(0402)]
 10K/F 4: CS31002FB26 [RES CHIP 10K 1/16W +1% (0402)]
 15K/F 4: CS31502FB24 [RES CHIP 15K 1/16W +1% (0402)]
 30K/F 4: CS33002FB13 [RES CHIP 30K 1/16W +1%(0402)]
 34.8K/F 4: CS33482FB22 [RES CHIP 34.8K 1/16W +1%(0402)]
 45.3K/F 4: CS34532FB18 [RES CHIP 45.3K 1/16W +1% (0402)]

Default: Hynix VRAM

	Logical Strapping Bit3	Logical Strapping Bit2	Logical Strapping Bit1	Logical Strapping Bit0	
ROM_SO	NB10X	XCLK_417	FB_0_BAR_SIZE	SMB_ALT_ADDR	VGA_DEVICE
ROM_SCLK	PCI_DEVID[4]	SUB_VENDOR	SLOT_CLK_CFG	PEX_PLL_EN_TERM	0010
ROM_SI	RAMCFG[3]	RAMCFG[2]	RAMCFG[1]	RAMCFG[0]	XXXX
STRAP2	PCI_DEVID[3]	PCI_DEVID[2]	PCI_DEVID[1]	PCI_DEVID[0]	1000
STRAP1	3GIO_PADCFG[3]	3GIO_PADCFG[2]	3GIO_PADCFG[1]	3GIO_PADCFG[0]	0001
STRAP0	USER[3]	USER[2]	USER[1]	USER[0]	1111

VRAM Configuration Table

RAMCFG [3:0]	DESCRIPTION	Vendor	Vendor P/N	ROM_SI
0000		Reserved		
0001		Reserved		
0010	DDR3 64Mx16x4, 128bit, 512MB, 800MHz	Hynix	H5TQ1G63BFR-12C	PD 15K/F
0011	DDR3 64Mx16x4, 128bit, 512MB, 800MHz	Samsung	K4W1G1646E-HC12	PD 20K/F
0101		Reserved		
0110	DDR3 128Mx16x4, 128bit, 1GB, 800MHz	Hynix	H5TQ2G63BFR-12C	PD 34.8K/F
0111	DDR3 128Mx16x4, 128bit, 1GB, 800MHz	Samsung	K4W2G1646B-HC12	PD 45.3K/F

(Ra)

For Discrete Only

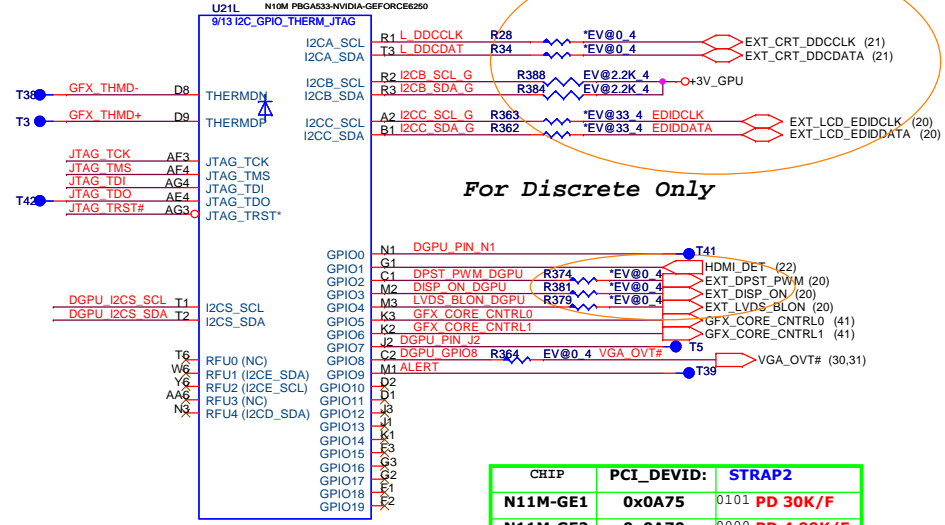

CHIP	PCI_DEVID:	STRAP2
N11M-GE1	0x0A75	0101 PD 30K/F
N11M-GE2	0x0A70	0000 PD 4.99K/F

VRAM Type	RAMCFG[0..3]	ROM_SI
Hynix AKD5LZGTW05	0x0A75	0010 PD15K/F
Samsung AKD5LGGT507	0x0A70	0011 PD 20K/F
Hynix AKD5MGGTW00	0x0A75	0110 PD 34.8K/F
Samsung AKD5MGGT501	0x0A70	0111 PD 45.3K/F

GPU Type	STRAP0	STRAP1	ROM_SO	ROM_SCLK
N11M-GE1	PU 45.3K/F	PU 34.8K/F	PD10K/F	PU15K/F
N11M-GE2	PU 45.3K/F	PU 34.8K/F	PD10K/F	PU15K/F

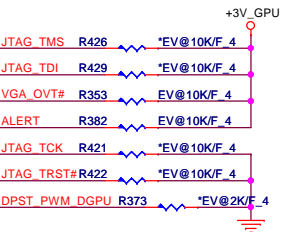
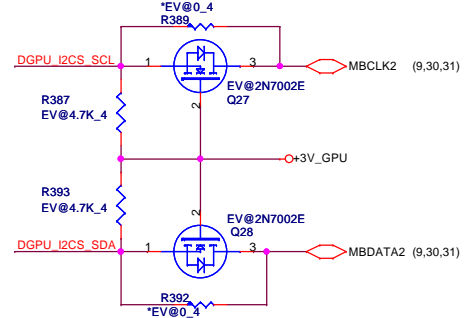

HDCP ROM

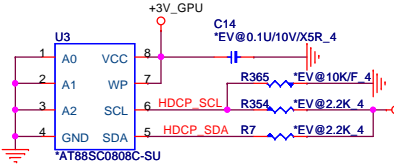

DHCP ROM	
HDCP_SCL	Low: Crypto ROM Hi: I2C ROM

GPIO ASSIGNMENTS

GPIO	I/O	ACTIVE	USAGE
0	N/A	N/A	
1	IN	N/A	Hot plug detect for IFP link C
2	OUT	HIGH	PANEL BACKLIGHT PWM
3	OUT	HIGH	PANEL POWER ENABLE
4	OUT	HIGH	PANEL BACKLIGHT ENABLE
5	OUT	N/A	NVDD VID0
6	OUT	N/A	NVDD VID1
7	OUT	N/A	NVDD VID2
8	I/O	LOW	OVERT
9	I/O	LOW	ALERT
10	OUT	N/A	FBVREF SELECT
11	OUT	N/A	SLI SYNC0
12	IN	N/A	PWR_LEVEL
13	OUT	N/A	MEM_VID or power supply control
14	OUT	N/A	PS CONTROL

PROJECT : Z360
 Quanta Computer Inc.

CHANNEL A: 256MB/512MB DDR3

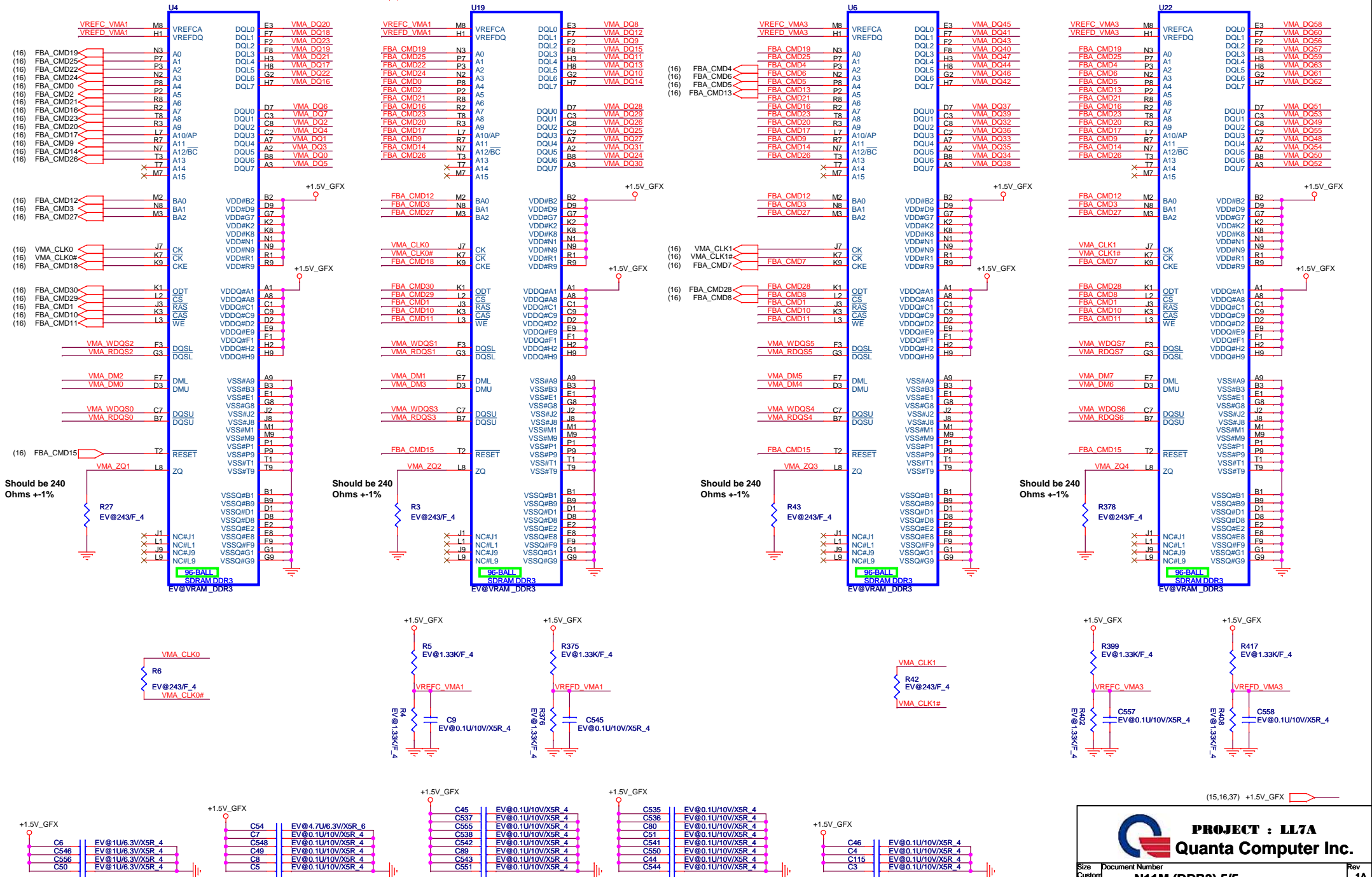

(15,16,37) +1.5V_GFX



PROJECT : LL7A
Quanta Computer Inc.

Size	Document Number		Rev
Custom	N11M (DDR3) 5/5		1A
Date:	Thursday, April 08, 2010	Sheet	19 of 42

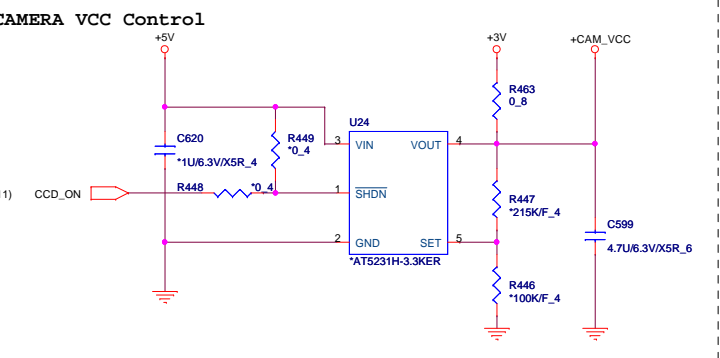
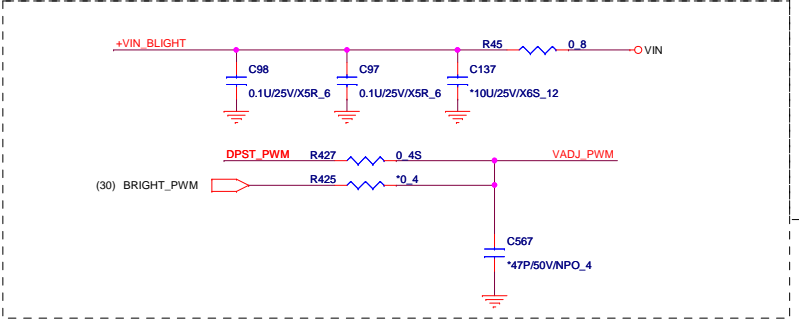
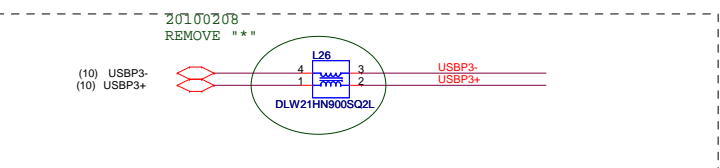
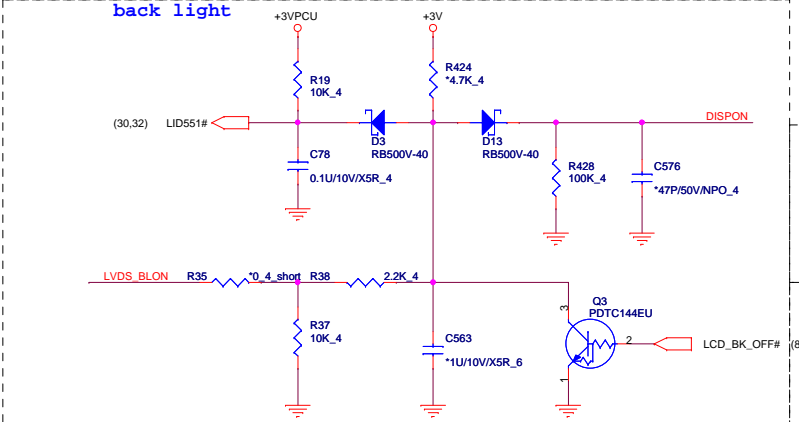
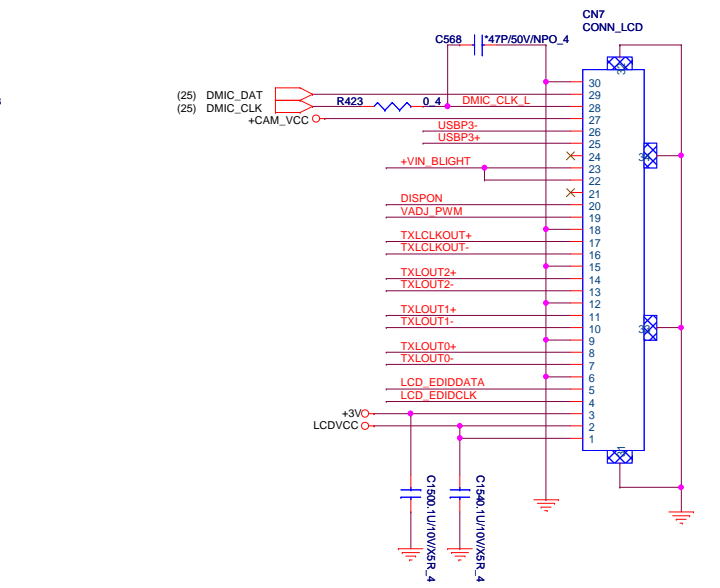
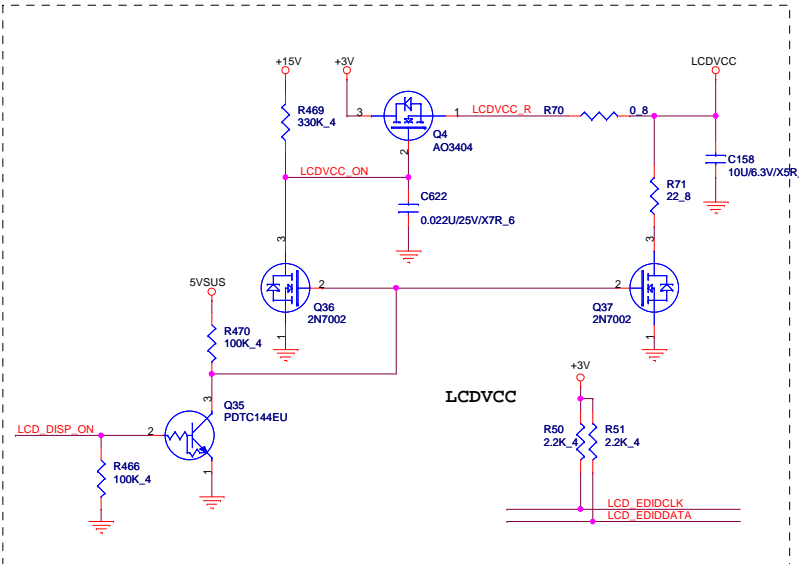
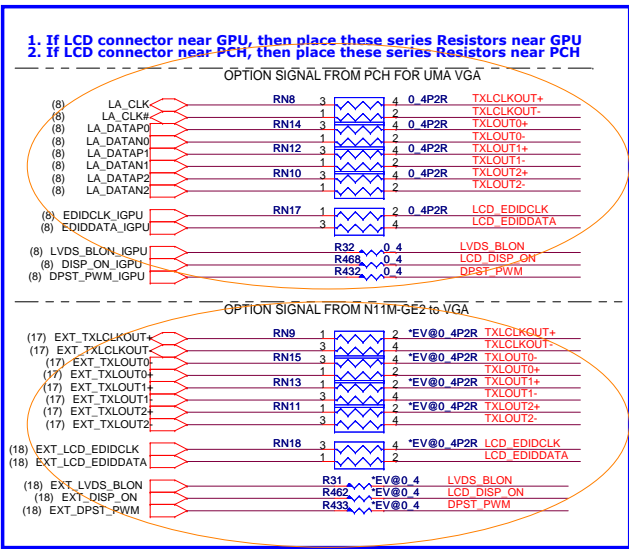

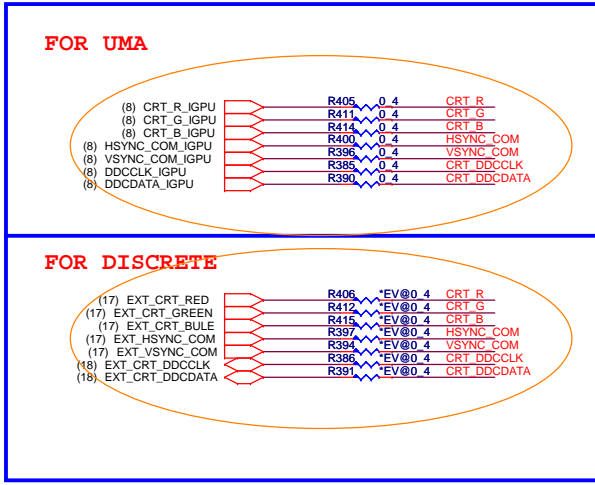
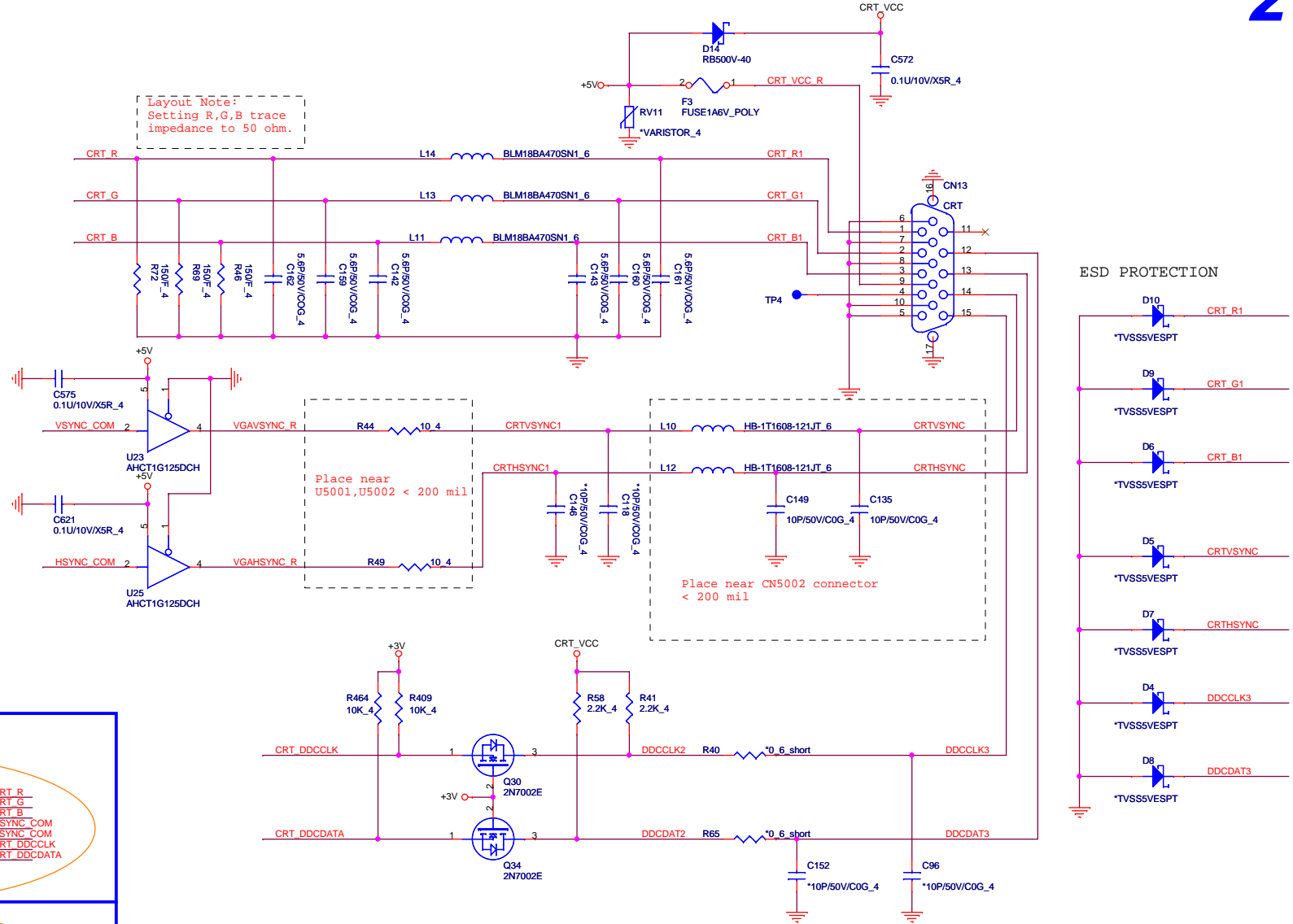

Signals		PDT	CHR	PIM
PC1	Ra	NC	NC	NC
HDMI_CFG0	Rb	NC	NC	NC
HDMI_CFG1	Rc	4.7K	NC	NC
REXT	Rd	499	1.2K	4.7K
PC1	Re	NC	4.7K	4.7K
HDMI_OE#	Rf	NC	4.7K	NC
PC0	Rg	4.7K	4.7K	4.7K

Signals		PDT		
EMI0	Rh	NC	NC	NC
EMI1	Ri	NC	NC	NC
ASQ0	Rj	4.7K	NC	NC
ASQ1	Rk	499	1.2K	4.7K

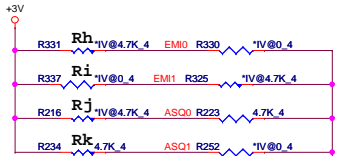

Signals	PS8171		
PIN 3	LEVEL	BQ	
	HIGH	7db	
PC0/PEQ	MID	2db	
	LOW	4db	

Signals	PS8171		
PIN 4	LEVEL	BQ	
	HIGH	1.2db	
PC1/PIO	MID	2db	
	LOW	0db	

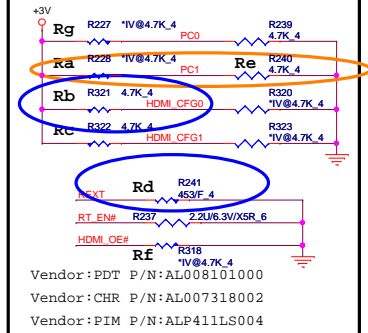

Vendor: PDT P/N:AL008101000
 Vendor: CHR P/N:AL007318002
 Vendor: PIM P/N:ALP411LS004

For UMA HDMI function

22

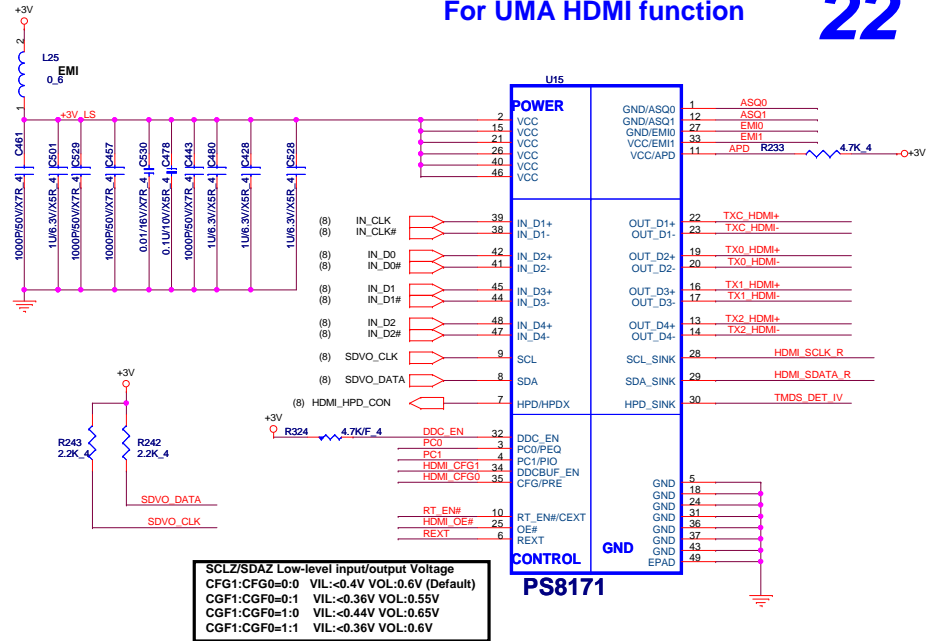

SCLZ/SDAZ Low-level input/output Voltage
 CFG1:CFG0=0:0 VIL:-0.4V VOL:-0.6V (Default)
 CFG1:CFG0=0:1 VIL:-0.36V VOL:-0.55V
 CFG1:CFG0=1:0 VIL:-0.44V VOL:-0.65V
 CFG1:CFG0=1:1 VIL:-0.36V VOL:-0.6V

FOR UMA ONLY FROM LEVEL SHIFTER

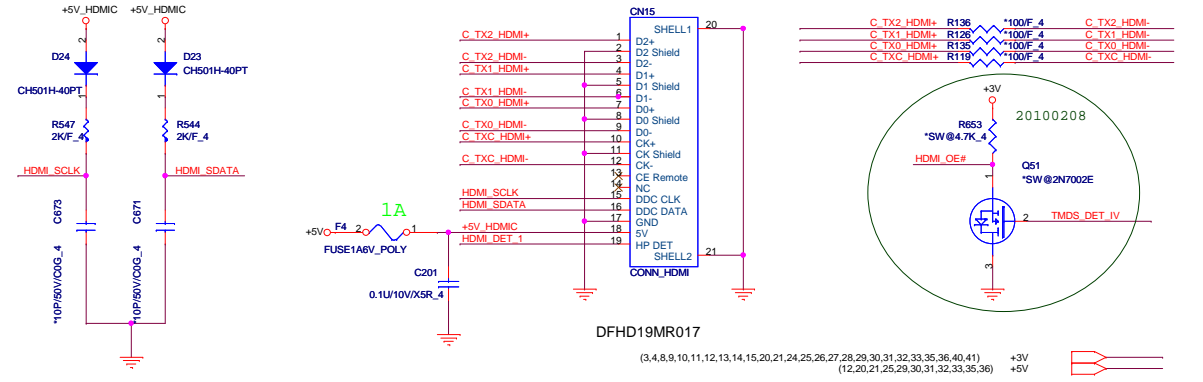
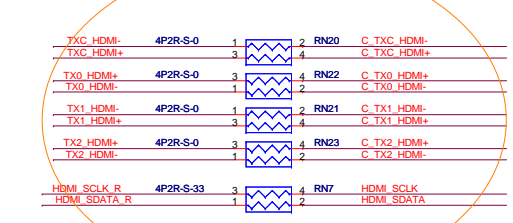

FOR DISCRETE PLACE CLOSE HDMI CONN

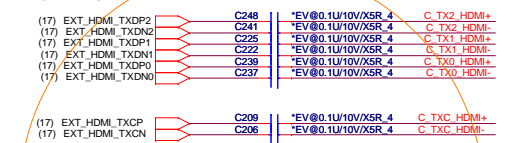

DISCRETE HDMI I2C SELECT Close to HDMI Connector

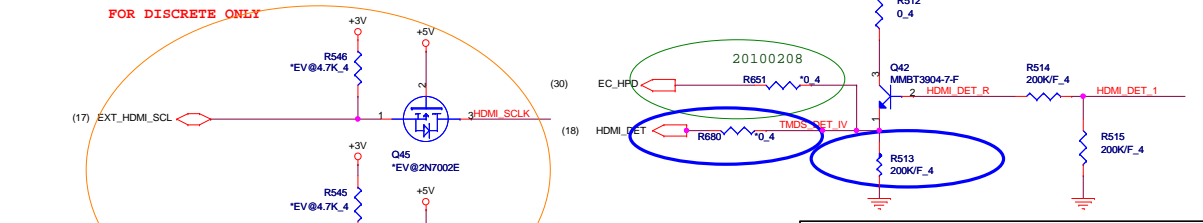

FOR DISCRETE ONLY

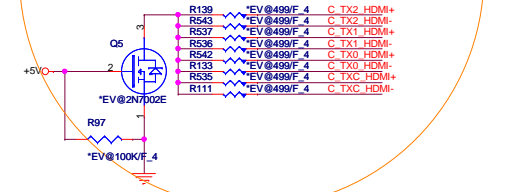

PROJECT : LL7A
Quanta Computer Inc.

Size Custom Document Number **HDMI CONN** Rev 3A
 Date: Friday, April 06, 2010 Sheet 22 of 42

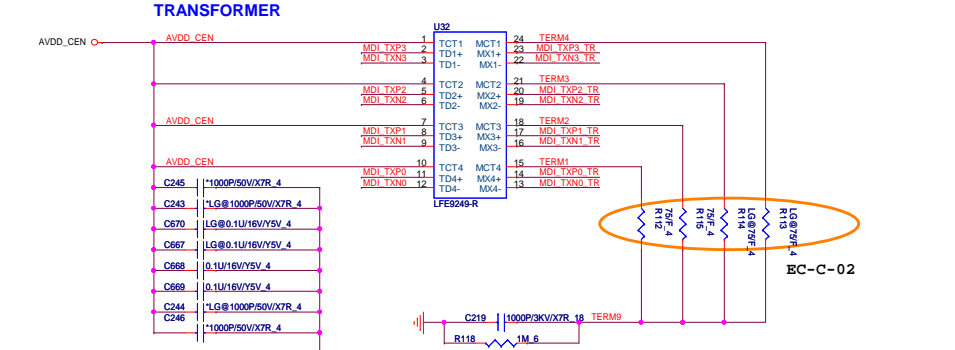
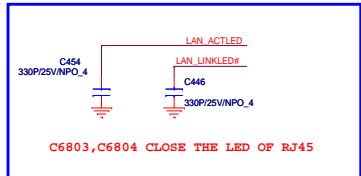
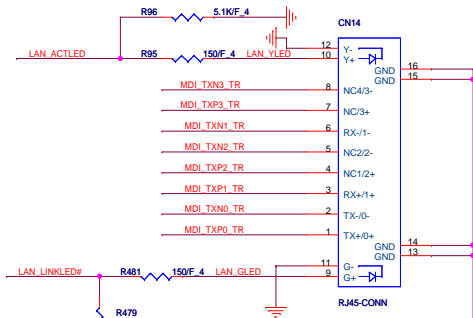
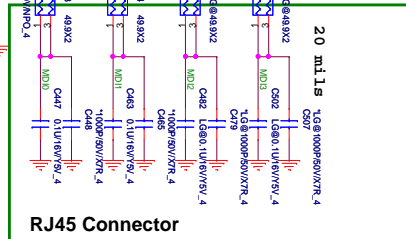
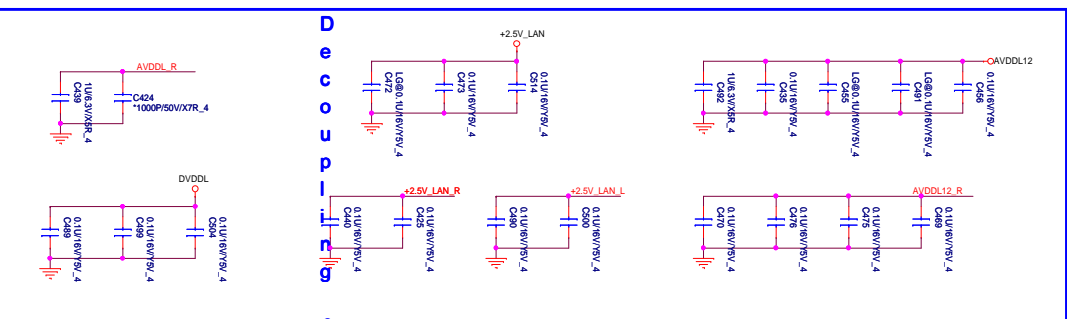
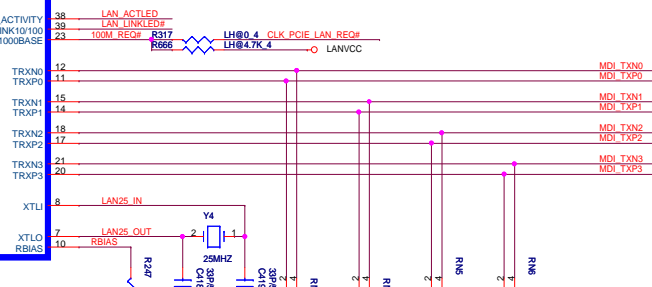
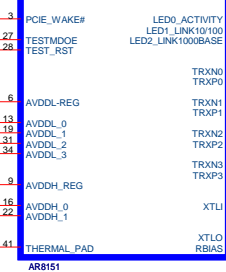
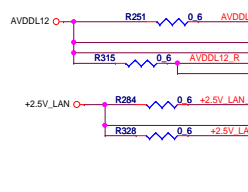
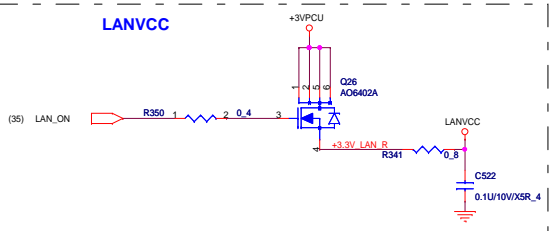
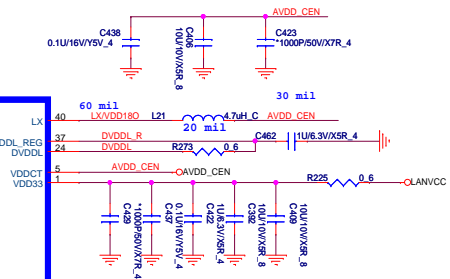
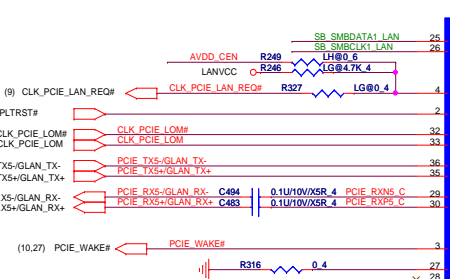
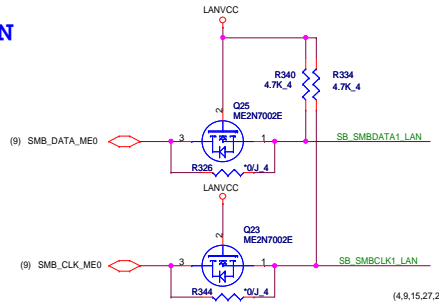

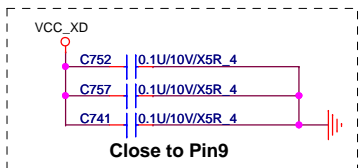
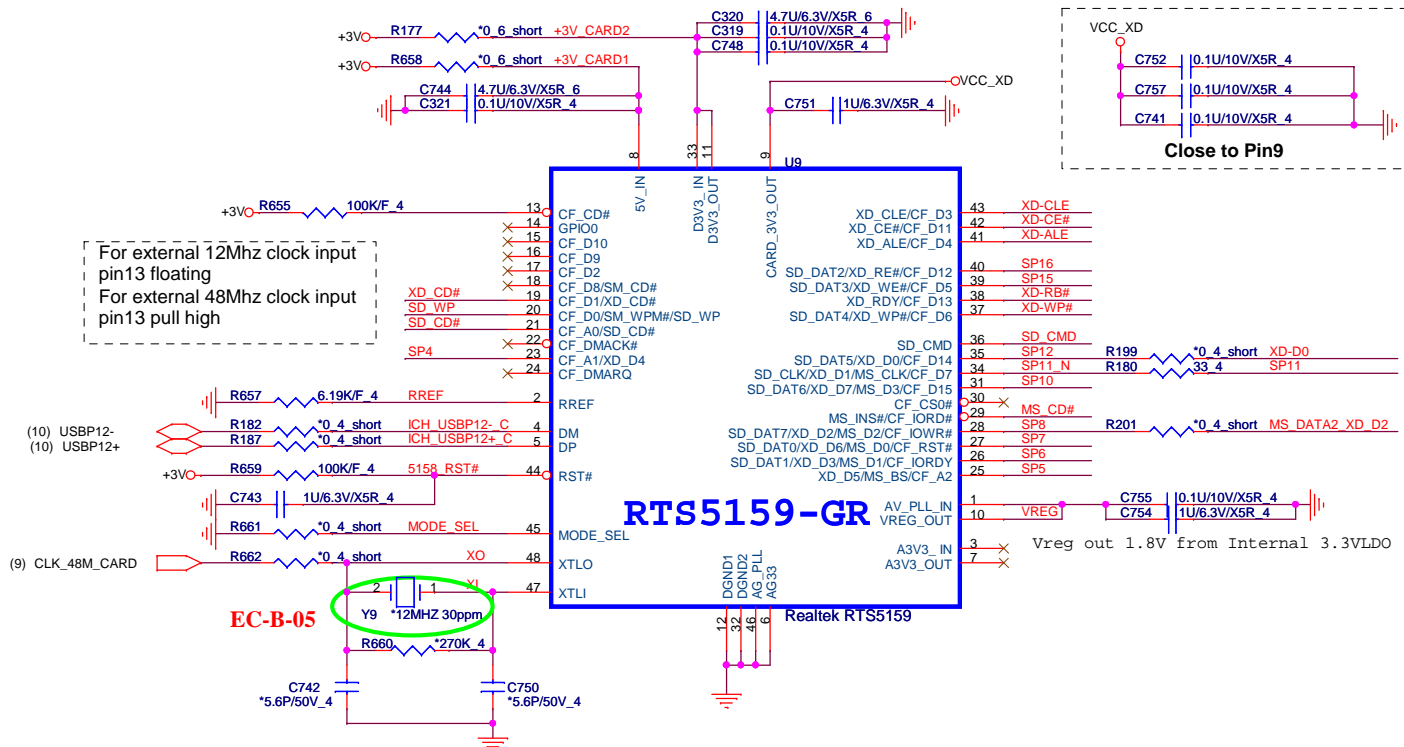

Note:

SP0	SD/MMC	MS	XD
SP1			XD_CD#
SP2	SD_WP		
SP3	SD_CD#		
SP4	SD_DAT1		XD_D4
SP5		MS_BS	XD_D5
SP6		MS_D1	XD_D3
SP7	SD_DAT0	MS_D0	XD_D6
SP8	SD_DAT7	MS_D2	XD_D2
SP9		MS_IN#	
SP10	SD_DAT6	MS_D3	XD_D7
SP11	SD_CLK	MS_SCLK	XD_D1
SP12	SD_DAT5		XD_D0
SP13	SD_DAT4		XD_WP#
SP14			XD_RB#
SP15	SD_DAT3		XD_WE#
SP16	SD_DAT2		XD_RE#
SP17			XD_ALE
SP18			XD_CE#
SP19			XD_CLE

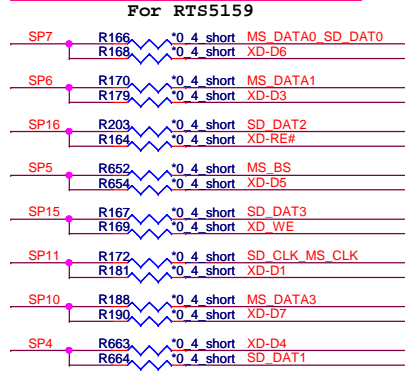

**5 IN1 CARD READER
XD, MMC/SD, MS/MSP**

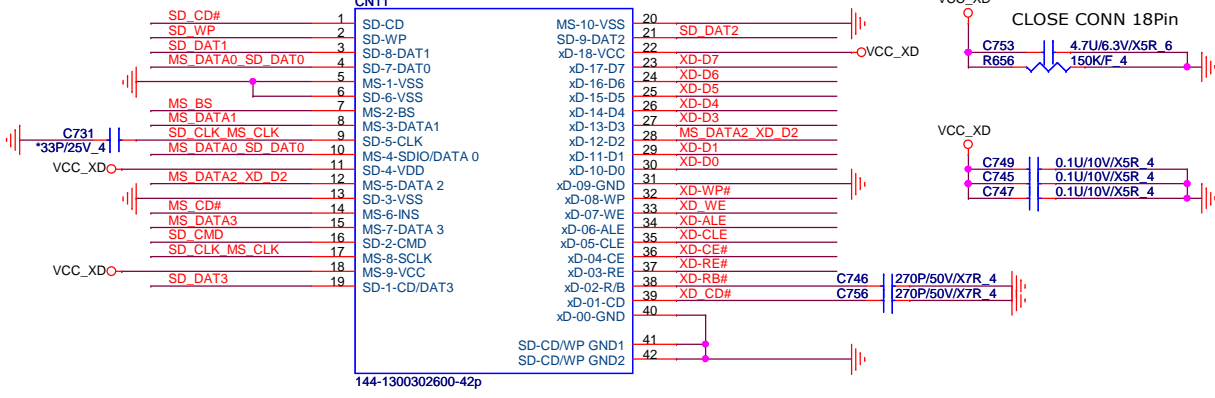

PROJECT : LL7A
Quanta Computer Inc.

Size Document Number Rev
CARD READER (Realtek RTS5159) 3A

Date: Thursday, April 08, 2010 Sheet 24 of 42

CODEC(ADO)

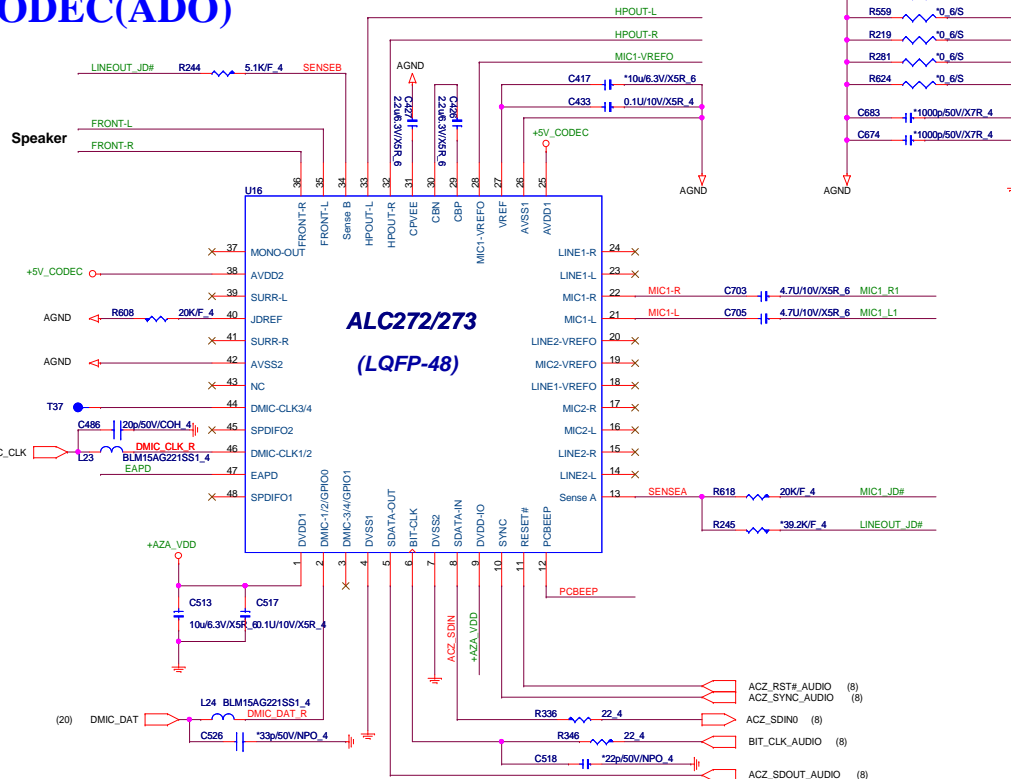

Speaker Amplifier(AMP)

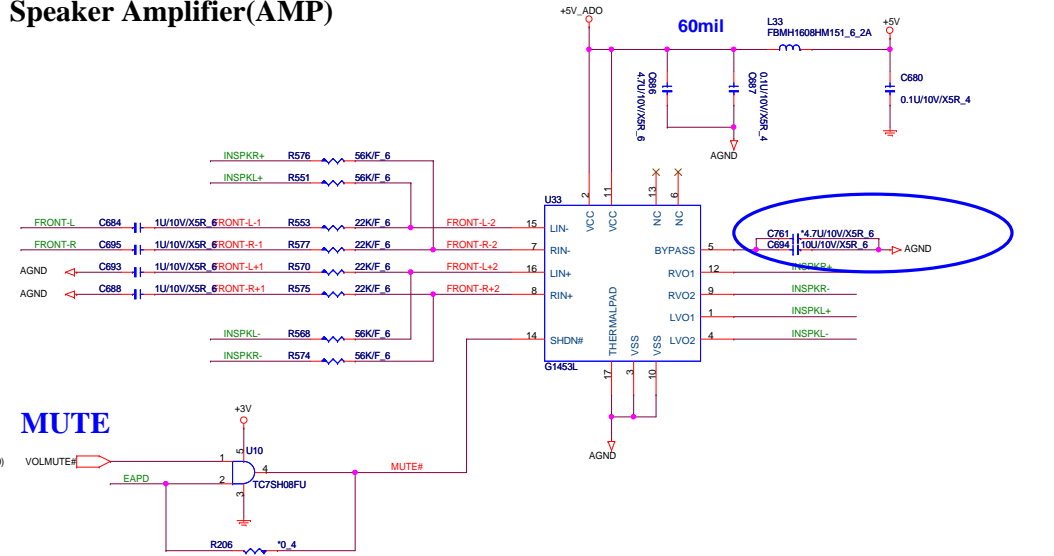

MUTE

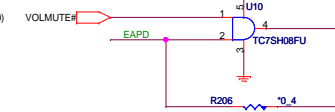

Codec Power(ADO)

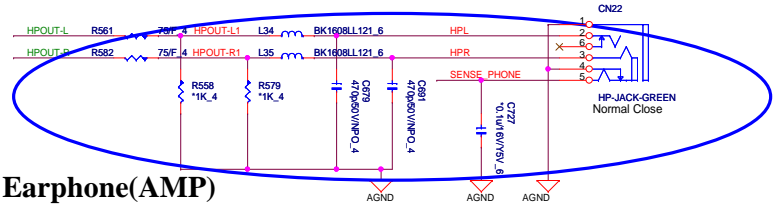
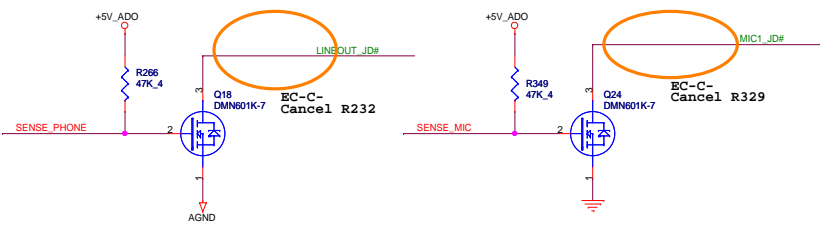
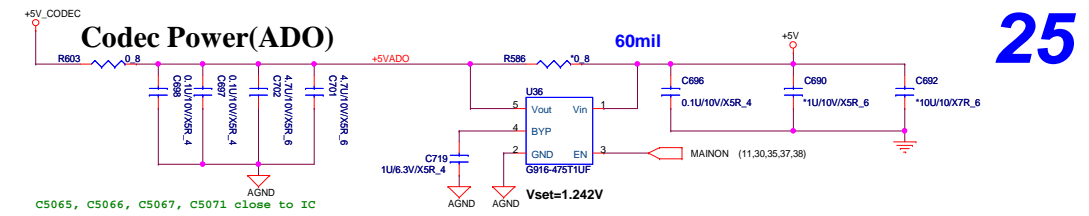

Earphone(AMP)

System MIC(AMP)

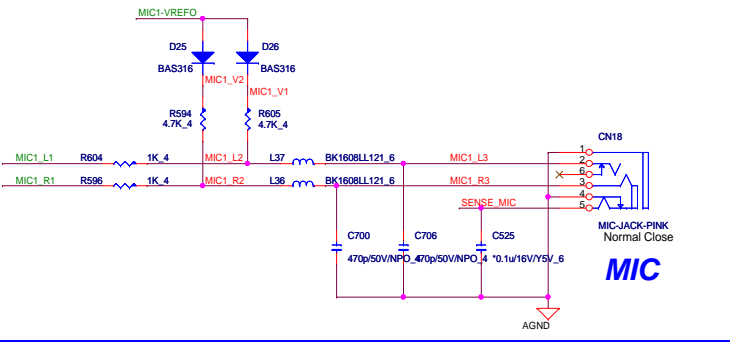

HDA Power(ADO)

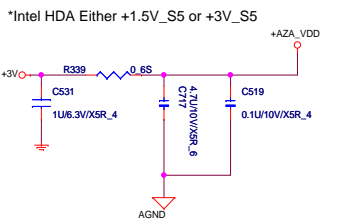

Speaker(AMP)

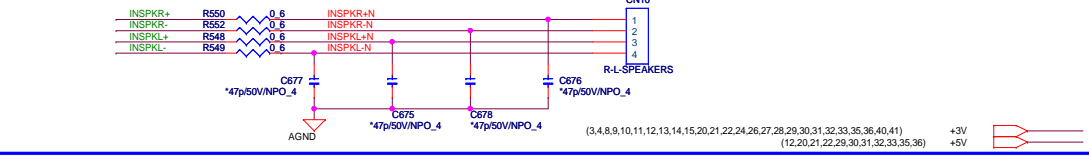

PC BEEP

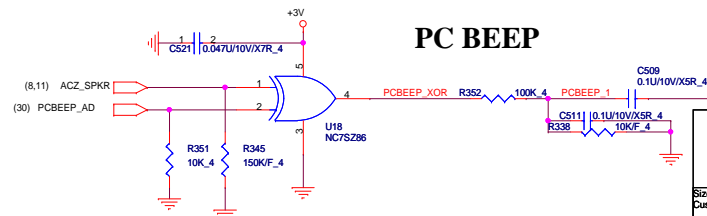

PROJECT : LL7A
Quanta Computer Inc.

Size: Custom Document Number: **AL272/AMP/MIC/HP/SPK** Rev: **3A**
 Date: Friday, April 08, 2010 Sheet: 25 of 42

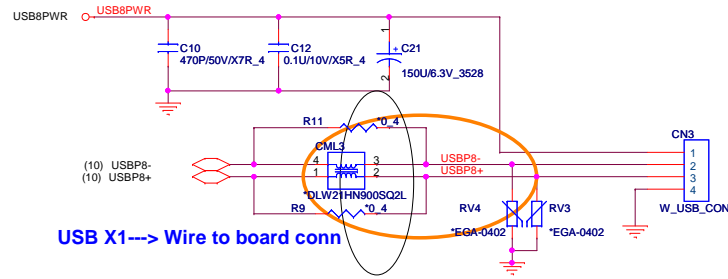
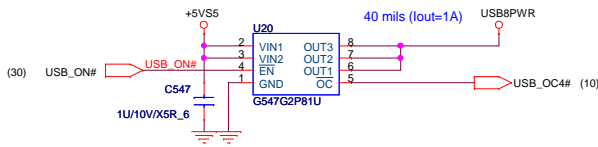

USB X1---> Wire to board conn

USB 2

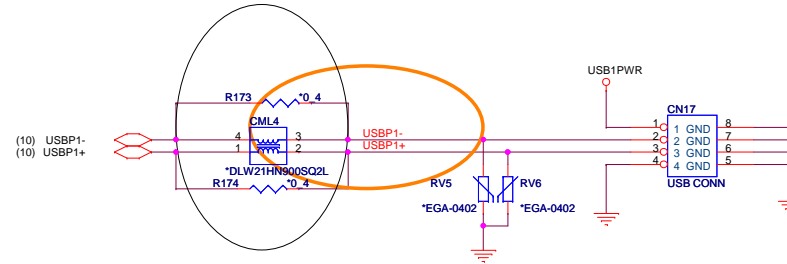
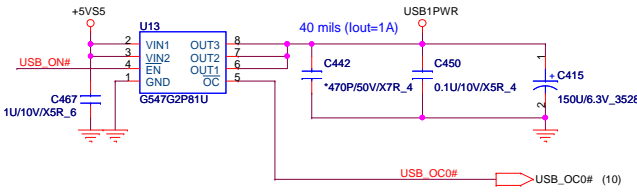

USB 1

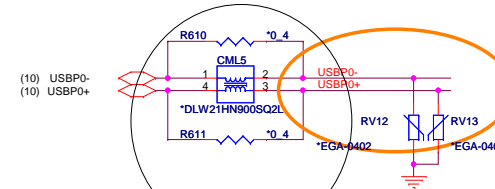
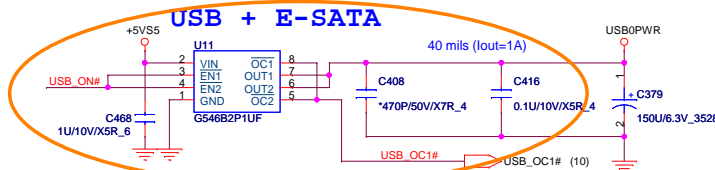

E-SATA RE-DRIVER

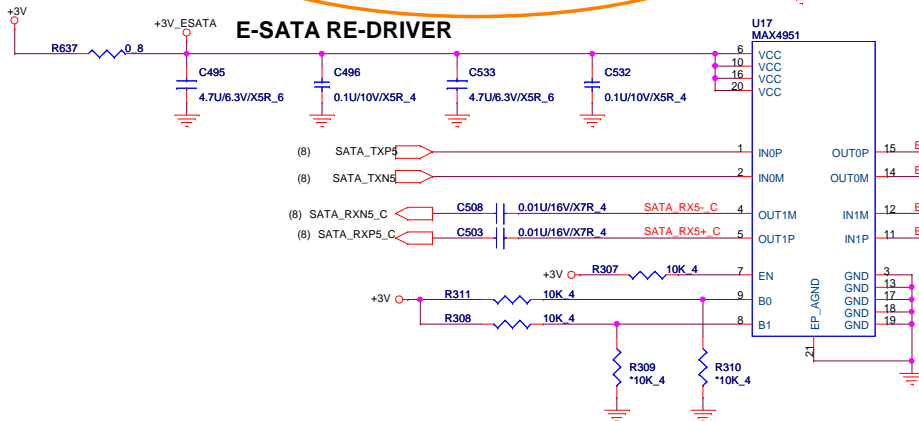

EN	B0	B1	FUNCTION
0	X	X	Standby
1	0	0	Standard SATA Output
1	1	0	Ch 0 Boost Output
1	0	1	Ch 1 Boost Output
1	1	1	Ch 0,1 Boost Output

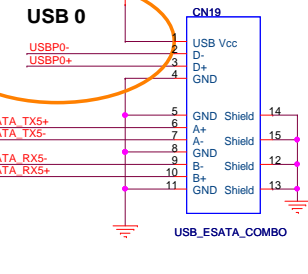

PROJECT : LL7A
Quanta Computer Inc.

MiniCard WLAN/WiMAX connector

(3,4,8,9,10,11,12,13,14,15,20,21,22,24,25,26,28,29,30,31,32,33,35,36,40,41) (3,28,37) +3V
 (4,8,9,10,11,12,15,35) +1.5V
 +3VSS

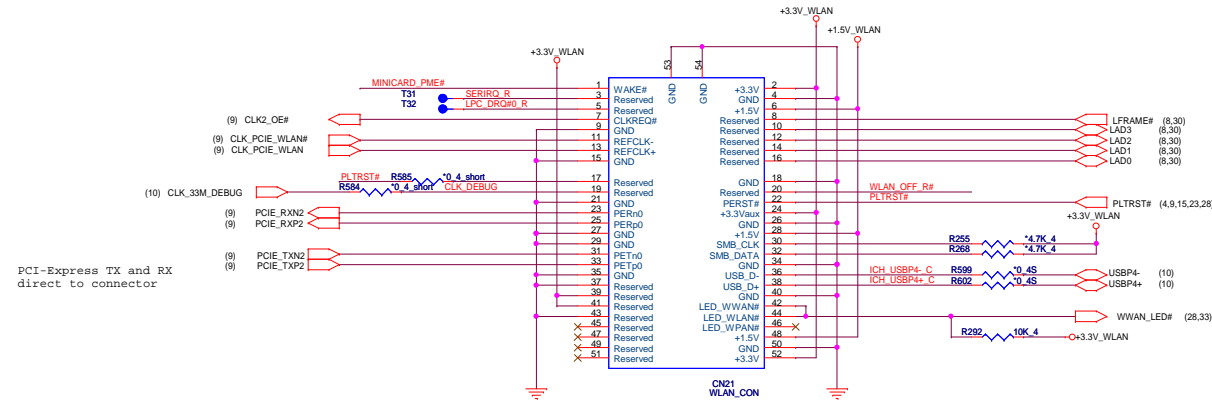

PCI-Express TX and RX direct to connector

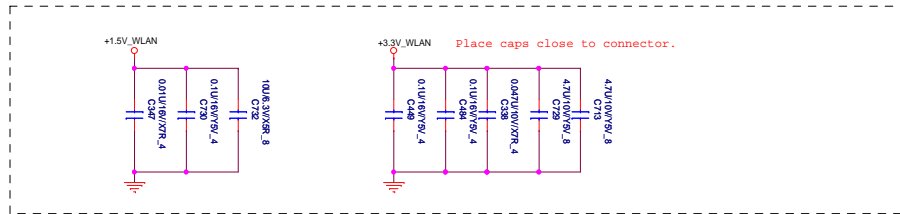
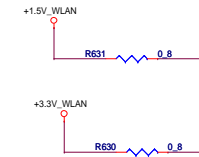
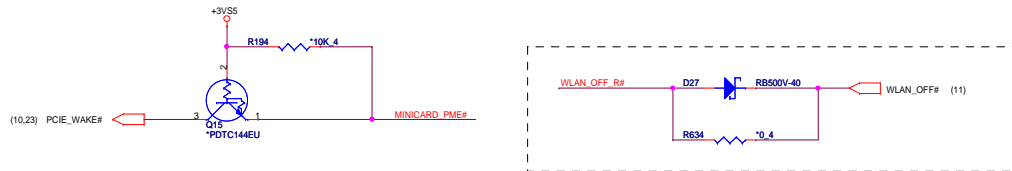
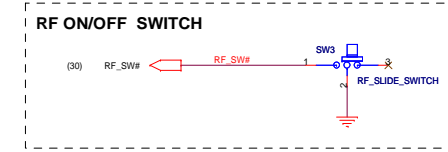

MiniCard WWAN connector

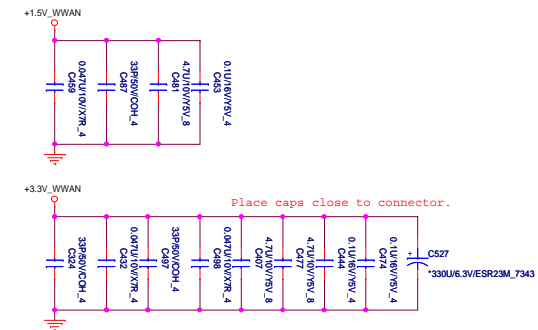
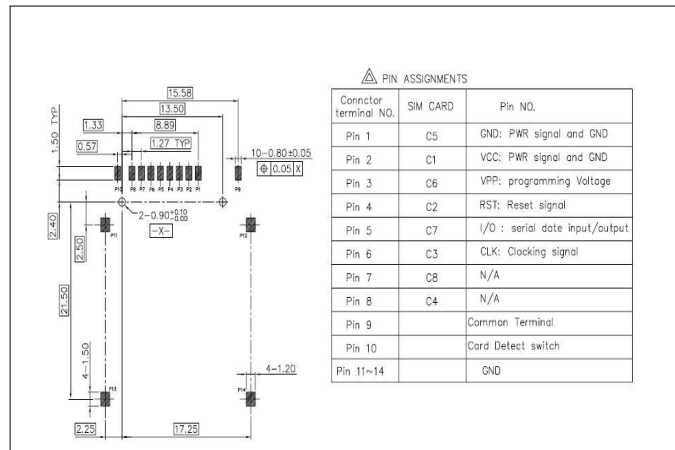
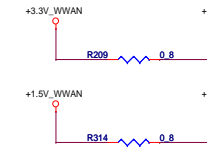
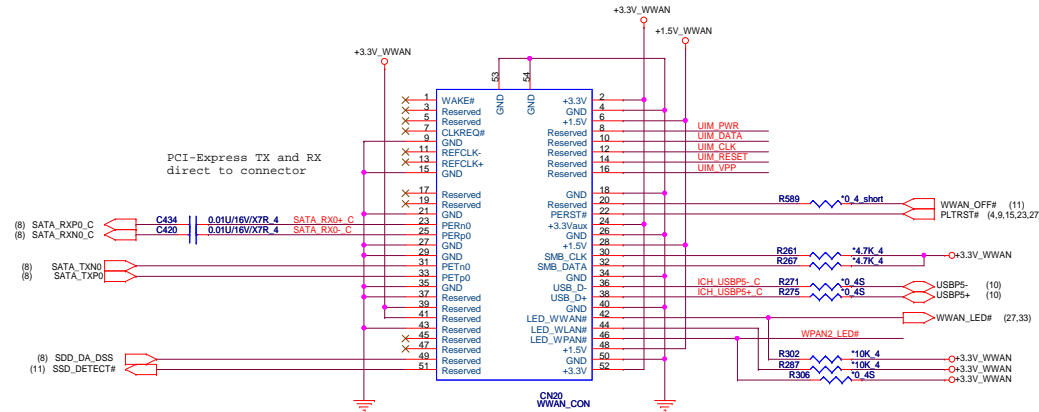

SIM Card CONN

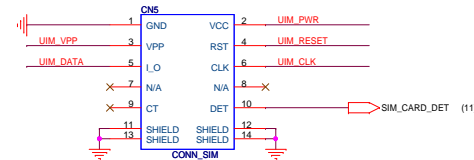

Layout Note:
 UIM_RESET, UIM_CLK, UIM_DATA routing as short as possible

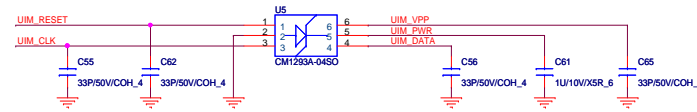

SATA-HDD CONNECTOR

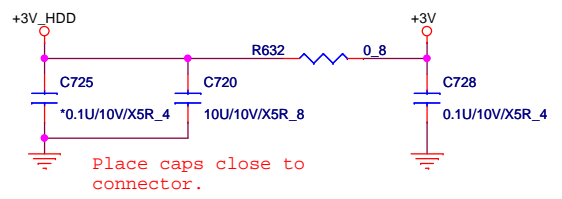
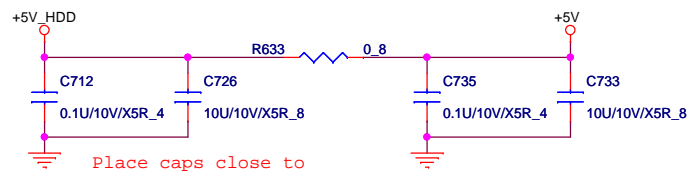
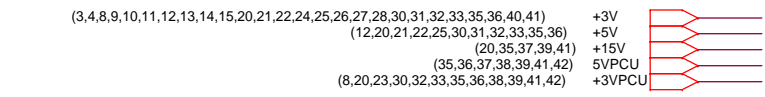
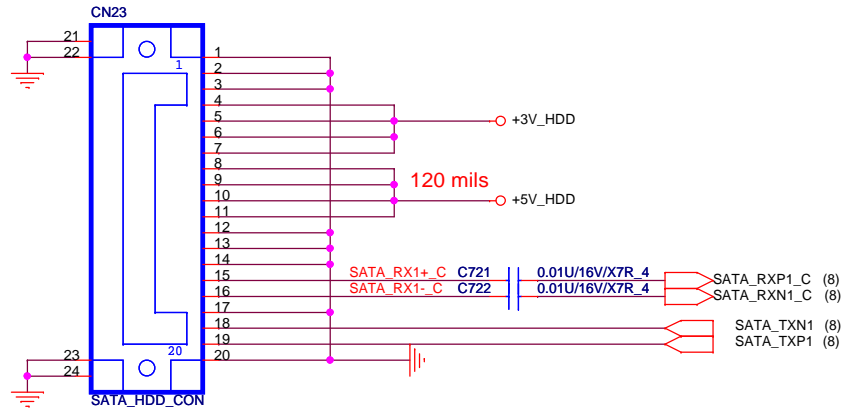

SATA CD-ROM

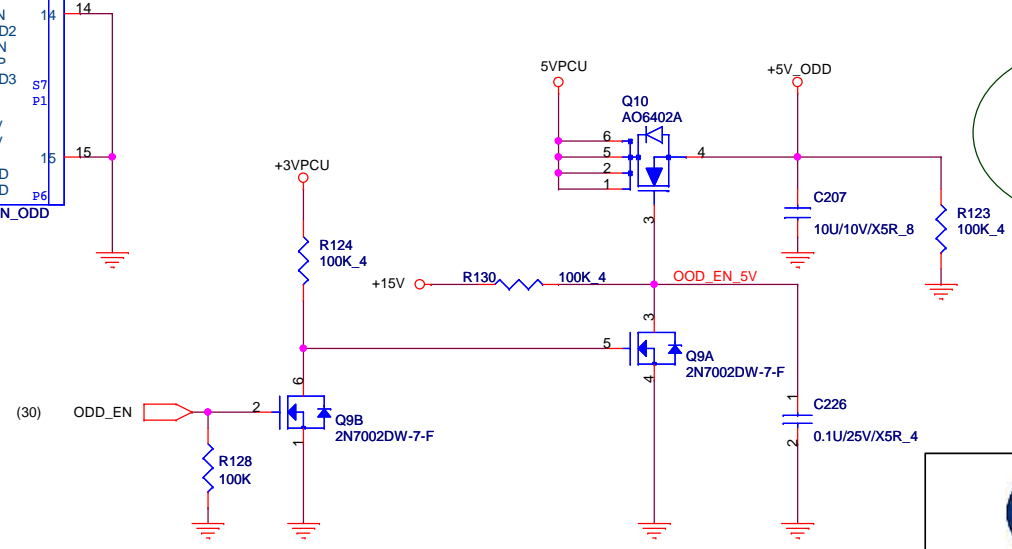
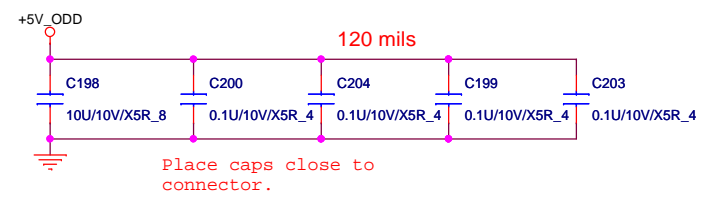
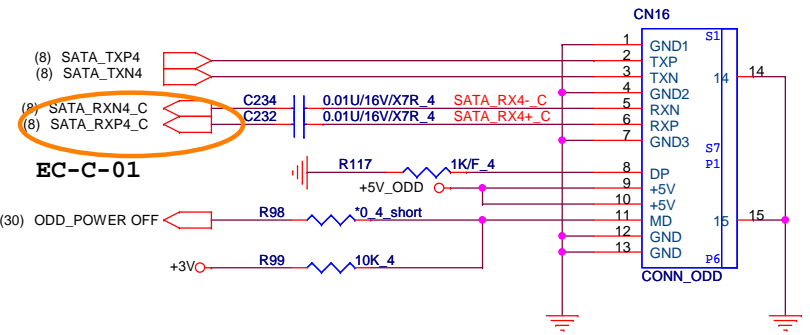

PROJECT : LL7A
Quanta Computer Inc.

Size	Document Number	Rev
Custom	HDD/ODD	3A
Date: Thursday, April 08, 2010		Sheet 29 of 42

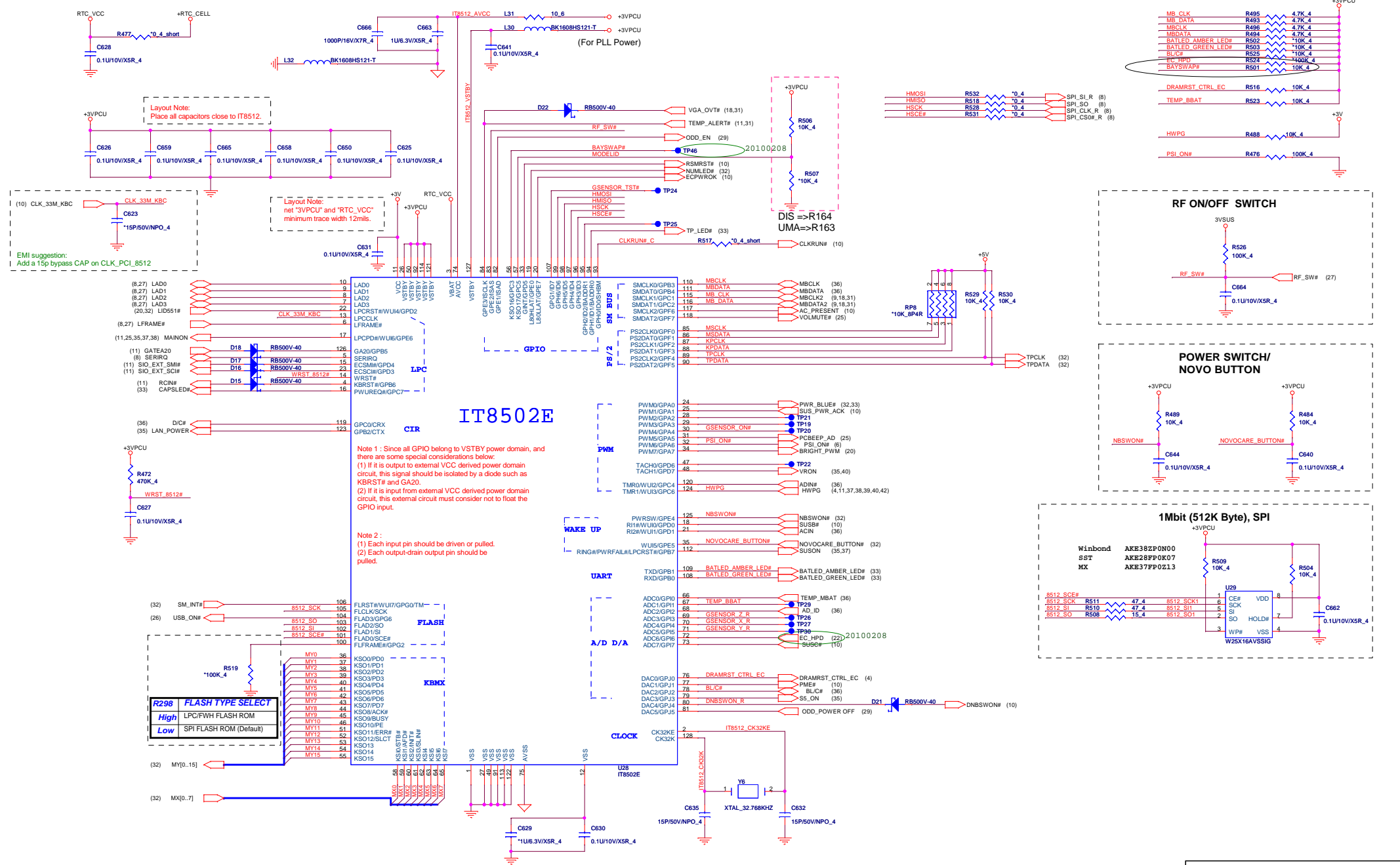

FAN CONTROL

(3,4,8,9,10,11,12,13,14,15,20,21,22,24,25,26,27,28,29,30,32,33,35,36,40,41)
 (12,20,21,22,25,29,30,32,33,35,36)

+3V
 +5V

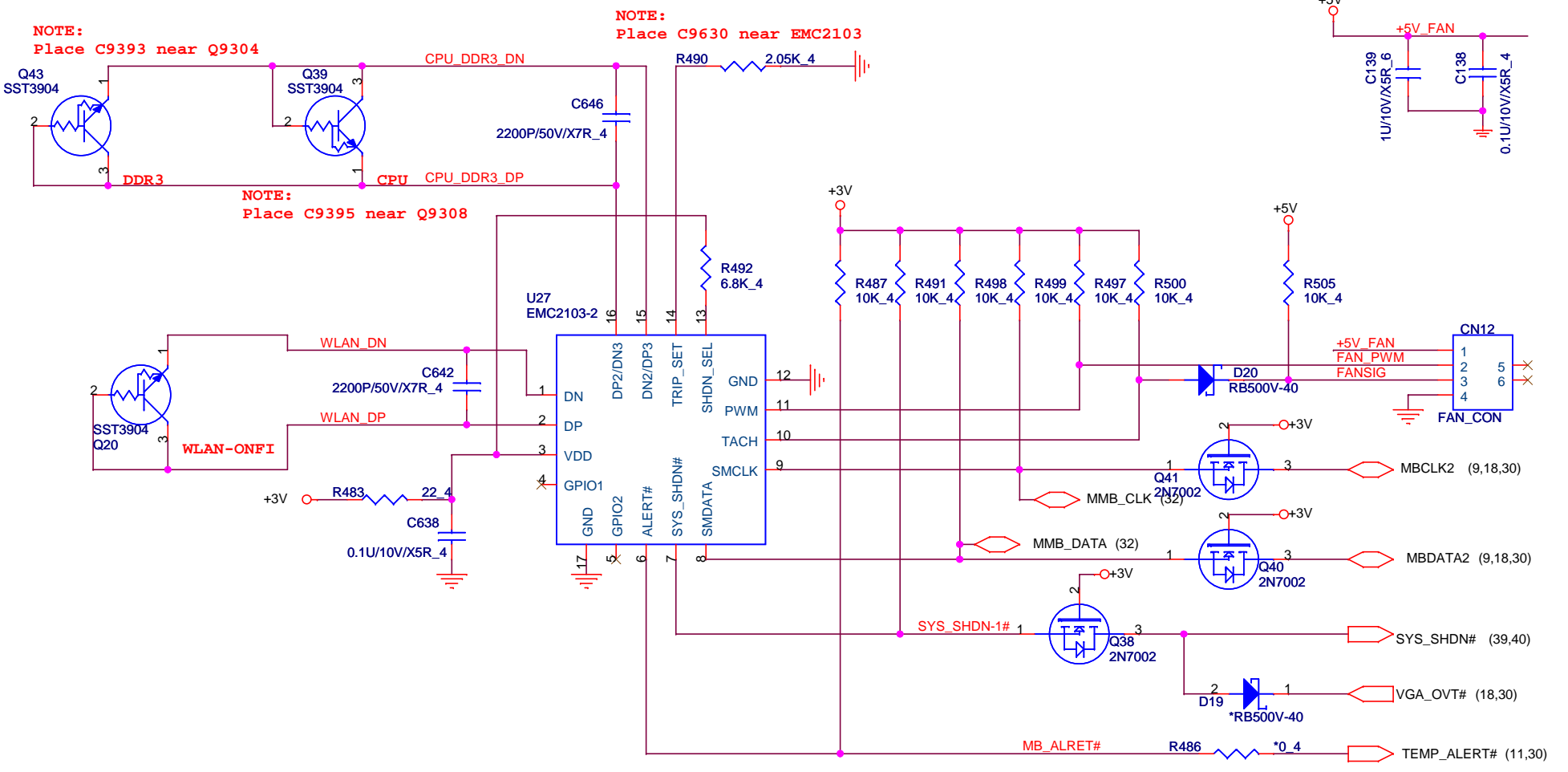



PROJECT : LL7A
Quanta Computer Inc.

Size	Document Number	Rev
Custom	FAN / THERMAL	1A
Date: Thursday, April 08, 2010		Sheet 31 of 42

KEYBOARD

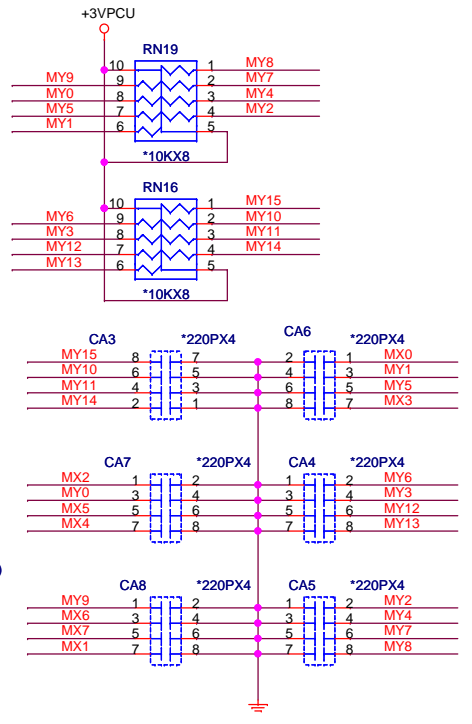
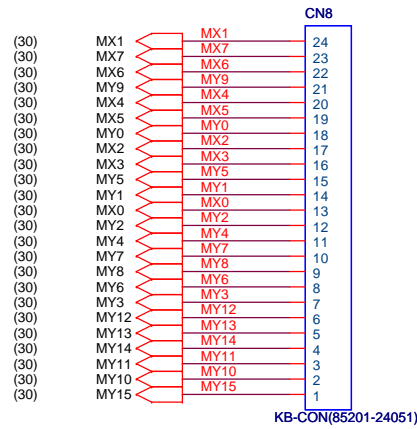

For EMI request

CAPACITANCE BUTTON BOARD

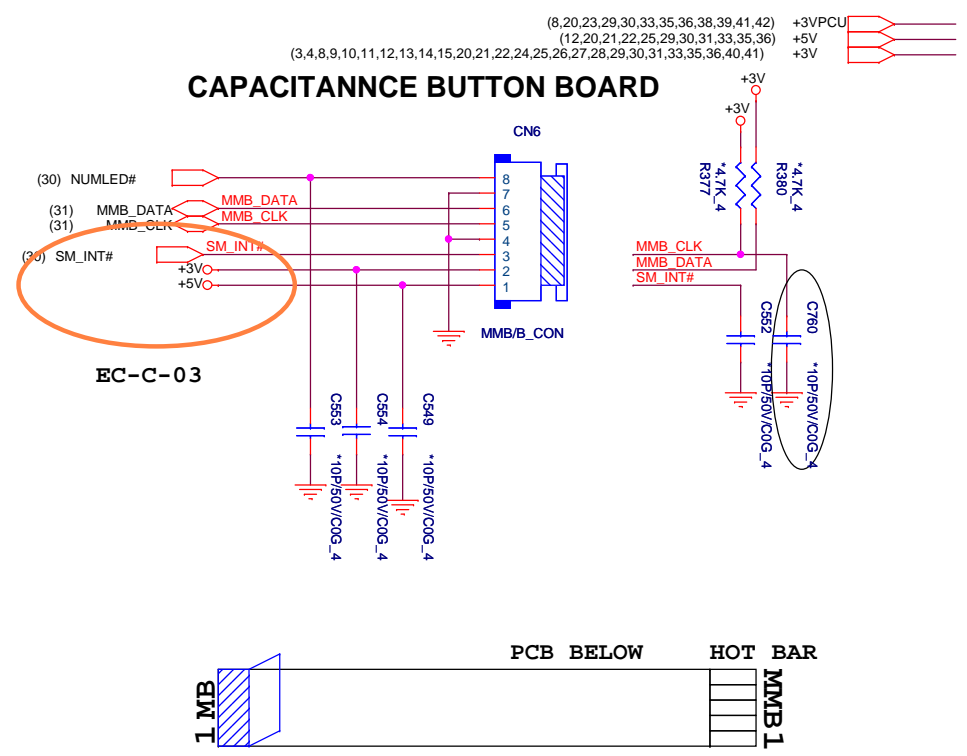

TOUCH PAD

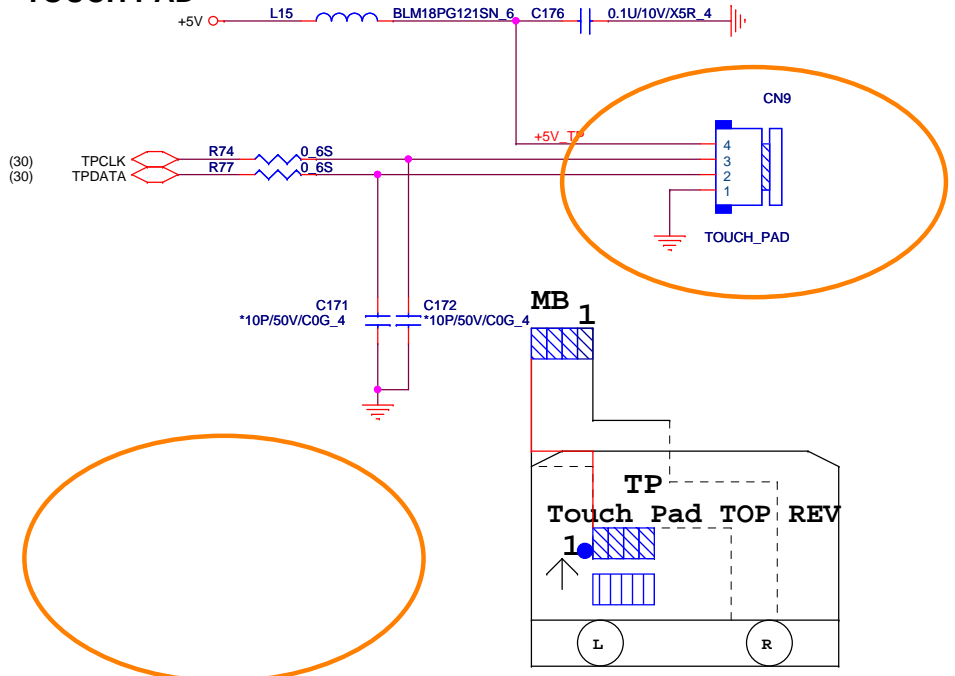

POWER BUTTON BOARD

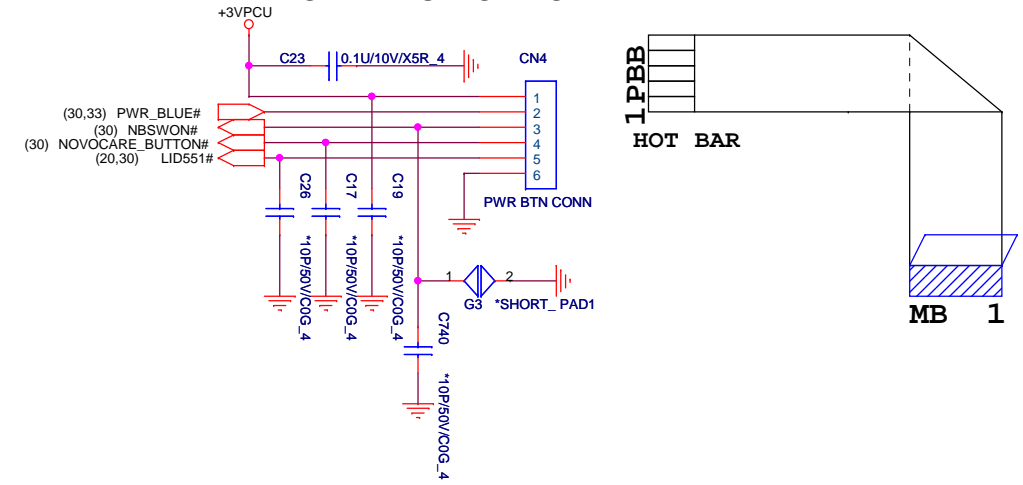



PROJECT : LL7A
Quanta Computer Inc.

Size	Document Number	Rev
Custorr	KB/TP/PW-B/CTS	3A
Date:	Thursday, April 08, 2010	Sheet 32 of 42

(3,4,8,9,10,11,12,13,14,15,20,21,22,24,25,26,27,28,29,30,31,32,35,36,40,41) +3V
 (12,20,21,22,25,29,30,31,32,35,36) +5V
 (8,20,23,29,30,32,35,36,38,39,41,42) +3VPCU

LED

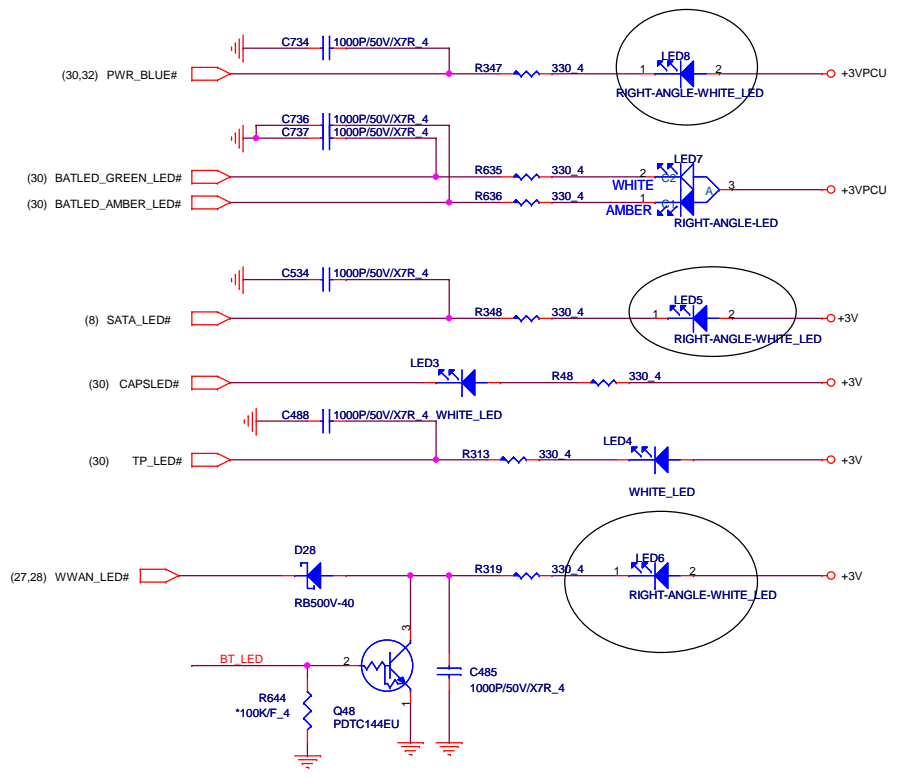

BLUETOOTH

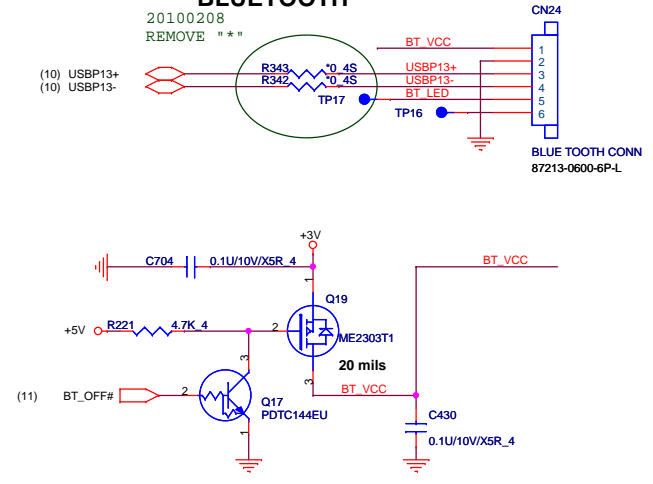

PROJECT : LL7A
Quanta Computer Inc.

Size	Document Number	Rev
Custom	LED/BT	1A
Date: Thursday, April 08, 2010		Sheet 33 of 42

CPU BKT

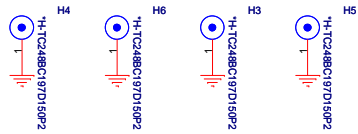

CRT HOLE

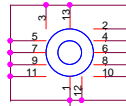

HOLE6
*H-C284D111P2-12
NEAR AUDIO JACK

GPU NUT

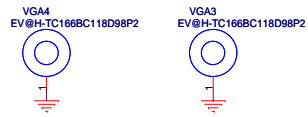

ODD HOLE



HOLE9
*H-C284I151D111P2

HOLE7
*H-C335D111P2

KEYBOARD HOLE

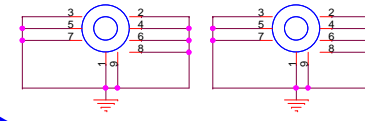

HOLE13
*H-C284D111P2-8

HOLE14
*H-C284D111P2-8

WLAN nut

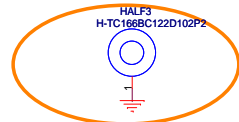

BATTERY HOLE



HOLE4
*H-C284D111P2-8

HOLE3
*H-C284D111P2-8

WLAN CABLE HOLE



HOLE15
*H-C38D98N

WWAN NUT

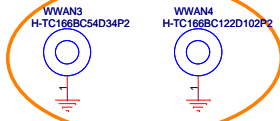

WLAN CABLE HOLE

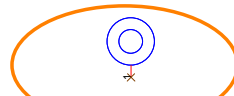

HOLE5
*O-LL7A-2

EMI BATTERY PAD

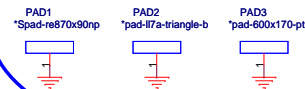

DDR 3 HOLE

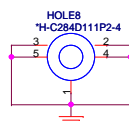

FRONT HOLE

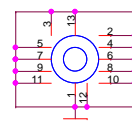

HOLE10
*H-C284D111P2-12
NEAR AUDIO JACK

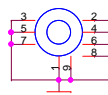

HOLE12
*H-C284D111P2-8
NEAR PCH BELOW

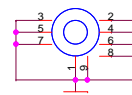

HOLE11
*H-C284D111P2-8

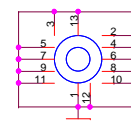

HOLE16
*H-C284D111P2-12
NEAR E-SATA

DISCHARGE

+3V, +5V

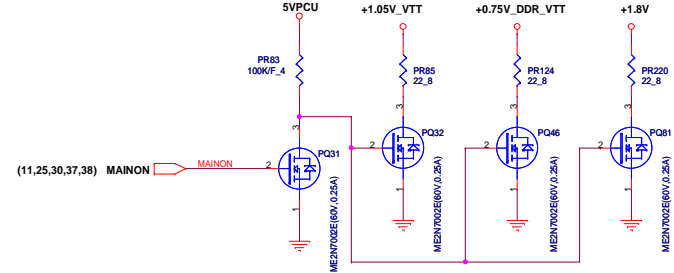
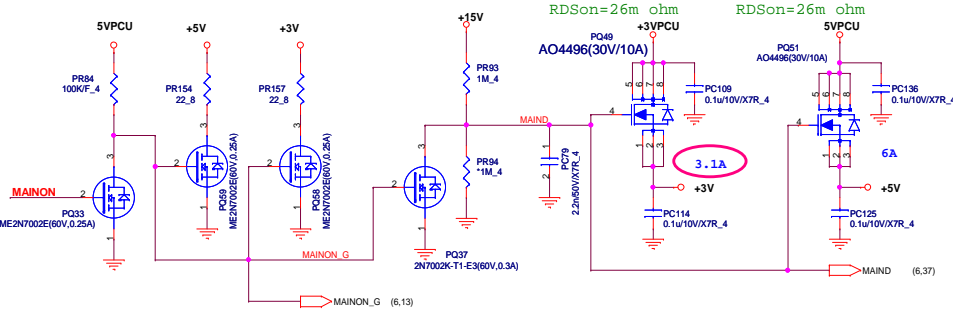

3V_S5, 5V_S5

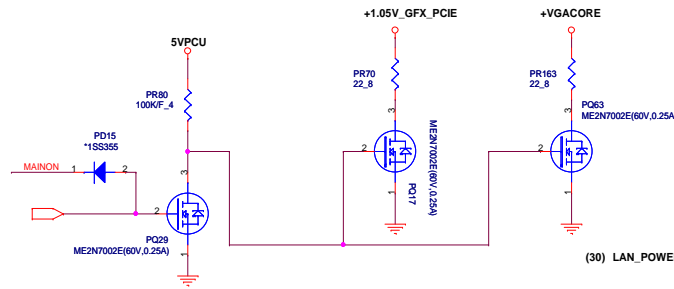
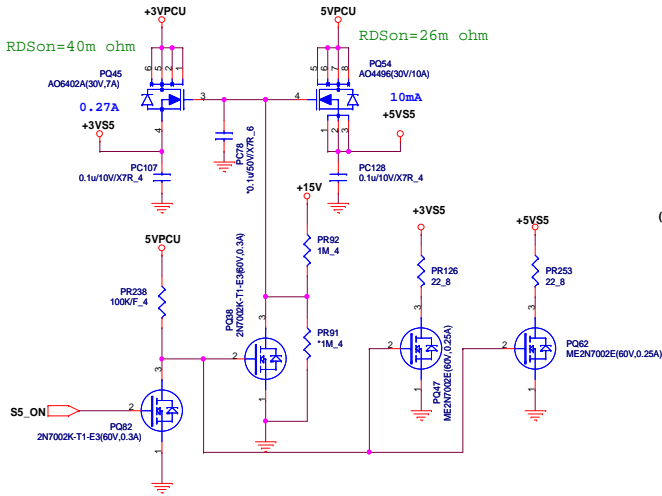

LANVCC

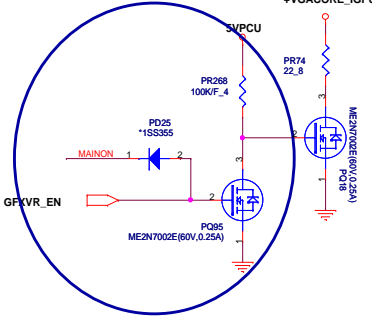
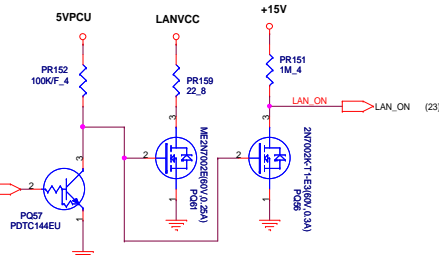

3VSUS, 5VSUS

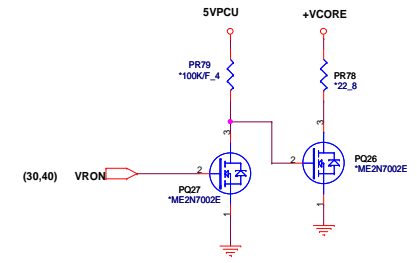
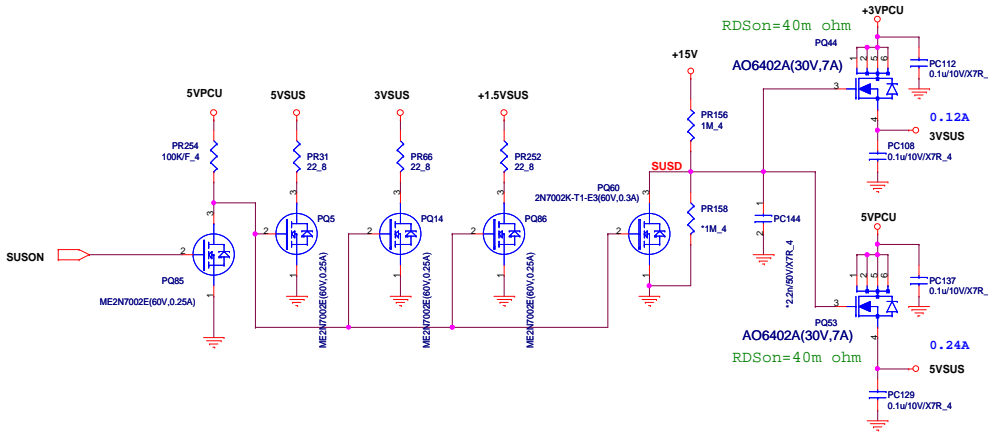

(20,29,37,39,41)	+15V
(3,4,8,9,10,11,12,13,14,15,20,21,22,24,25,26,27,28,29,30,31,32,33,36,40,41)	+3V
(12,20,21,22,25,29,30,31,32,33,36)	+5V
(5,12,38,41)	+1.8V
(3,4,6,8,9,10,11,12,38,40,42)	+1.05V_VTT
(13,14,37)	+0.75V_DDR_VTT
(29,36,37,38,39,41,42)	5VPCU
(8,20,23,29,30,32,33,36,38,41,42)	+3VPCU
(23)	LANVCC
(15,41)	+VGACORE
(15,16,17,41)	+1.05V_GFX_PCIE
(6,42)	+VGACORE_IGPU
(4,8,9,10,11,12,15,27)	+3VS5
(12,26)	+5VS5
(20,40,41)	5VSUS
(30,41)	3VSUS
(4,6,13,14,37,41)	+1.5VSUS
(6,40)	+VCORE

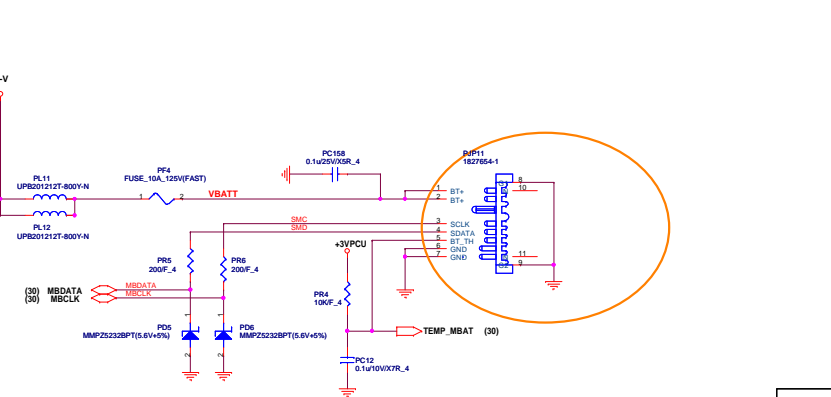
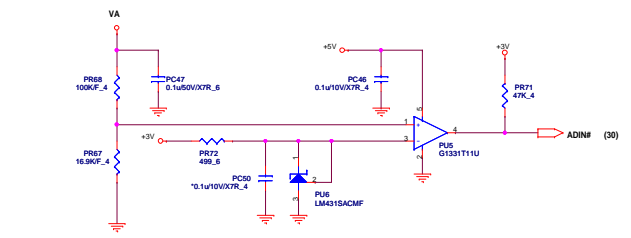
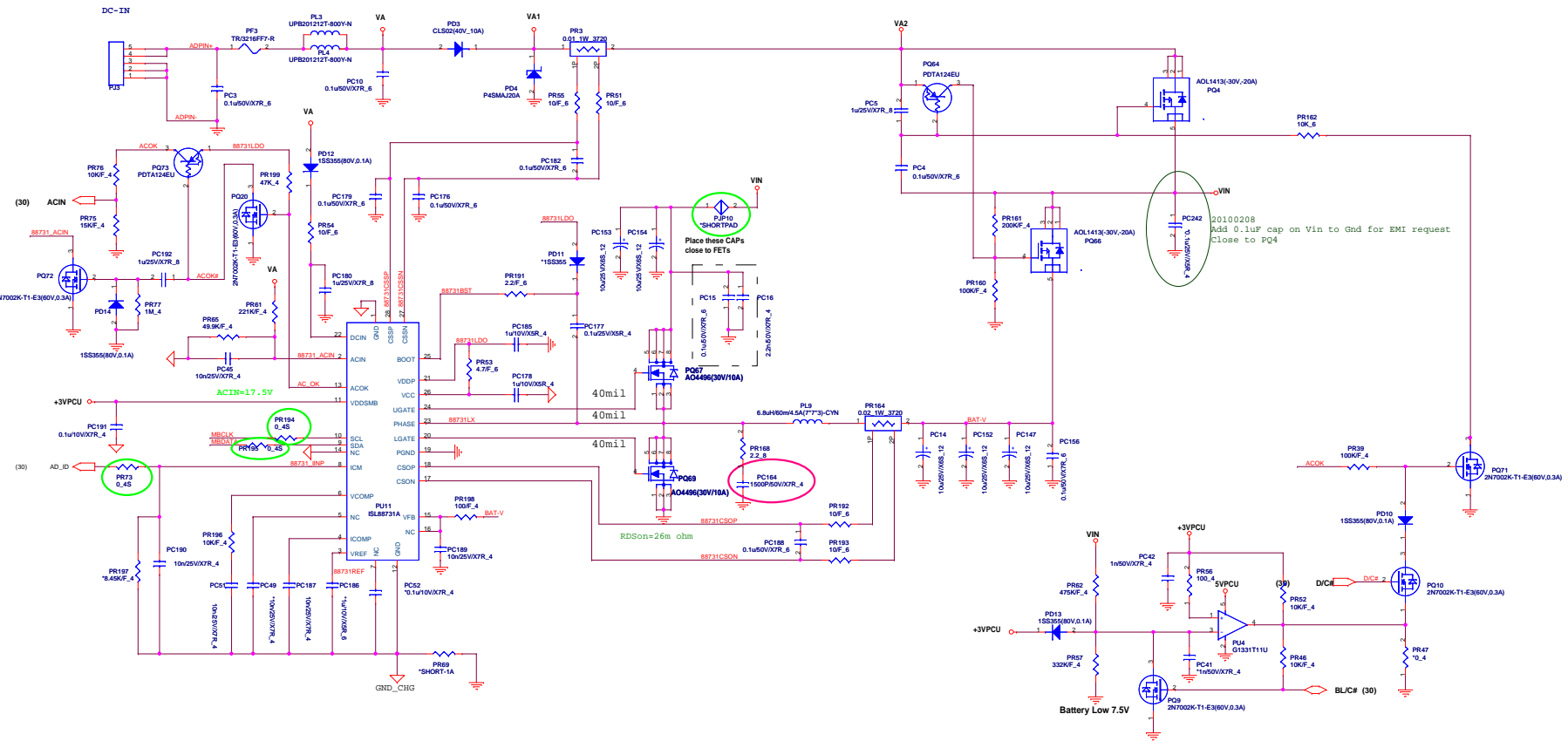

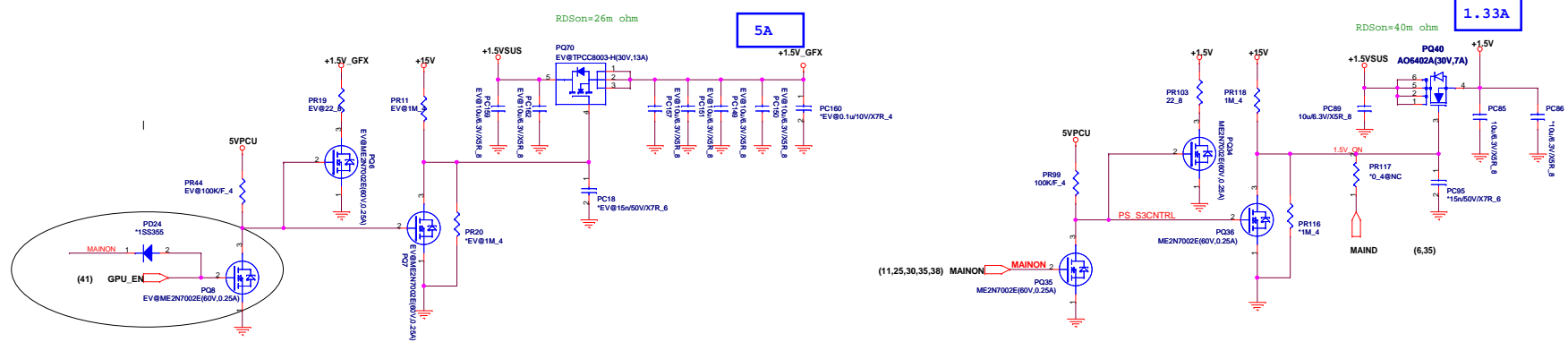
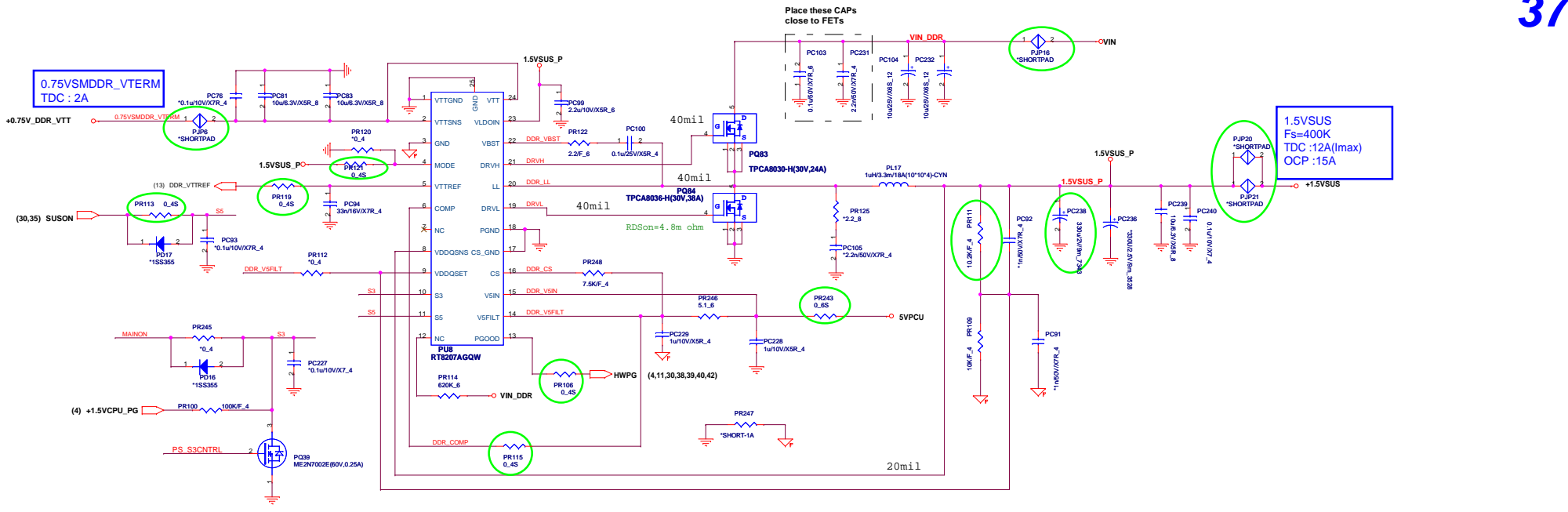

(3,20,36,37,39,40,41,42) VIN
 (3,4,6,8,9,10,11,12,35,40,42) +1.05V_VTT
 (6,12,35,41) +1.8V
 (8,20,23,29,30,32,33,35,36,39,41,42) +3VPCU
 (29,35,36,37,39,41,42) 5VPCU

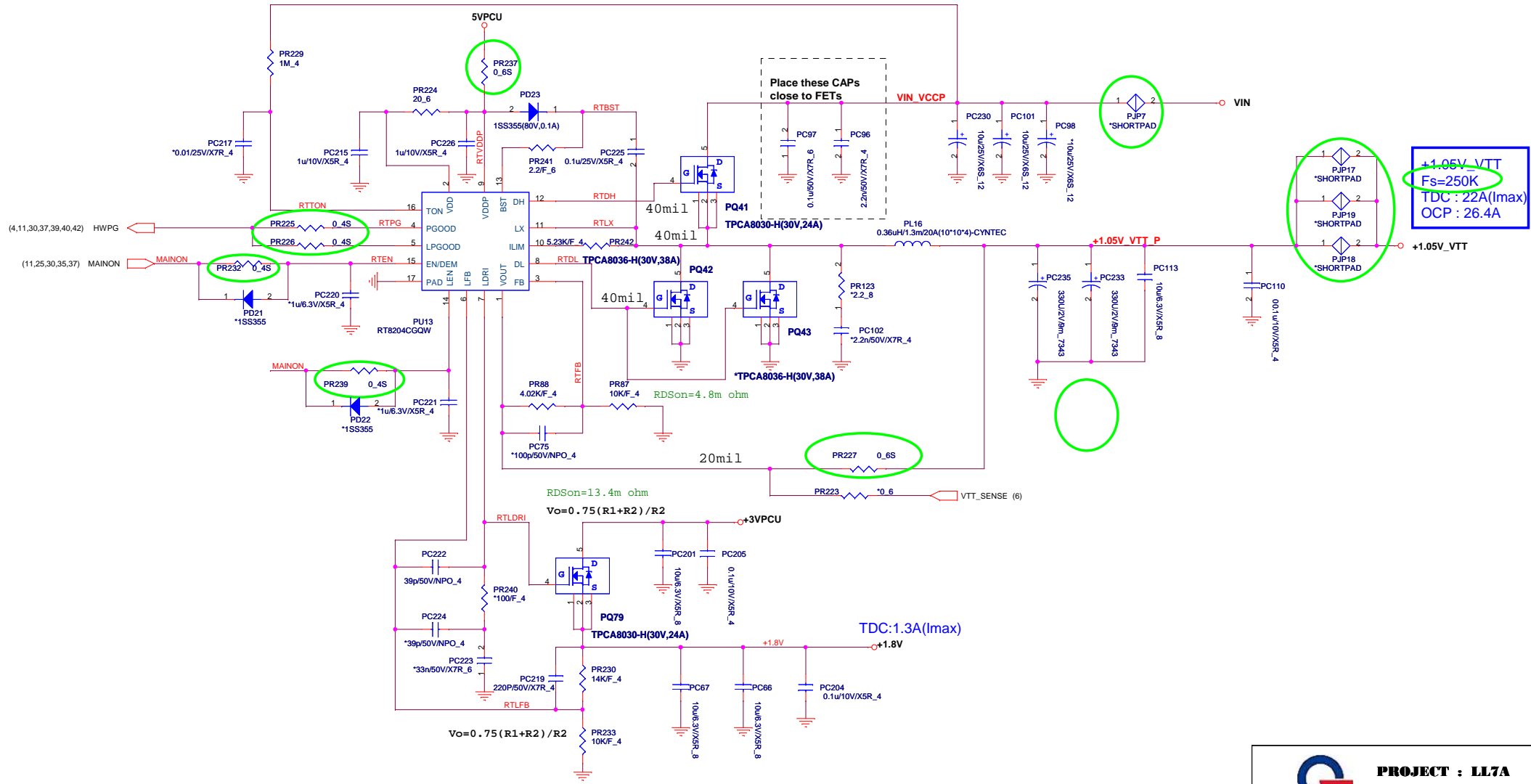

Place these CAPS
close to FETs

+1.05V_VTT
 Fs=250K
 TDC: 22A(I_{max})
 OCP: 26.4A

TDC:1.3A(I_{max})

$$V_o = 0.75 (R1 + R2) / R2$$

$$V_o = 0.75 (R1 + R2) / R2$$

PROJECT : LL7A
Quanta Computer Inc.

Size	Document Number	Rev
Custort	1.05V_VTT (RT8204C)	1A
Date:	Thursday, April 08, 2010	Sheet 38 of 42

(3,20,36,37,38,40,41,42) VIN
 (8,20,23,29,30,32,33,35,38,41,42) +3VPCU
 (29,35,36,37,38,41,42) 5VPCU
 (6,12,35,38,41) +1.8V
 (3,4,6,8,9,10,11,12,35,38,40,42) +1.05V_VTT

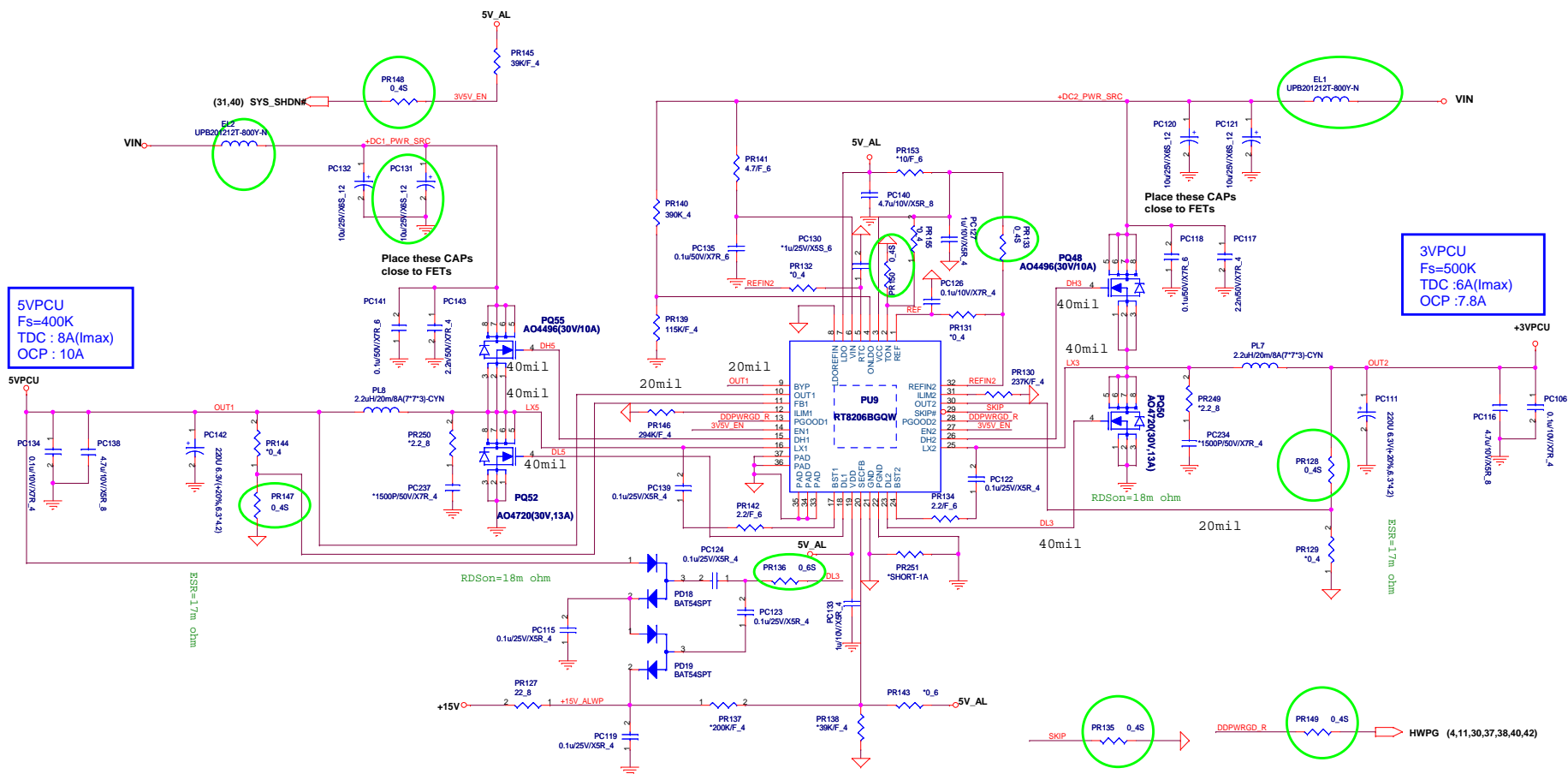
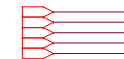

3VPCU
 Fs=500K
 TDC : 6A(I_{max})
 OCP : 7.8A

5VPCU
 Fs=400K
 TDC : 8A(I_{max})
 OCP : 10A

ESR=1.7m ohm

RDson=18m ohm

ESR=1.7m ohm

PROJECT : LL7A
Quanta Computer Inc.

Size C	Document Number	Rev 1A
	3V/5V (RT8206BGQW)	
Date: Thursday, April 06, 2010	Sheet 39	of 42

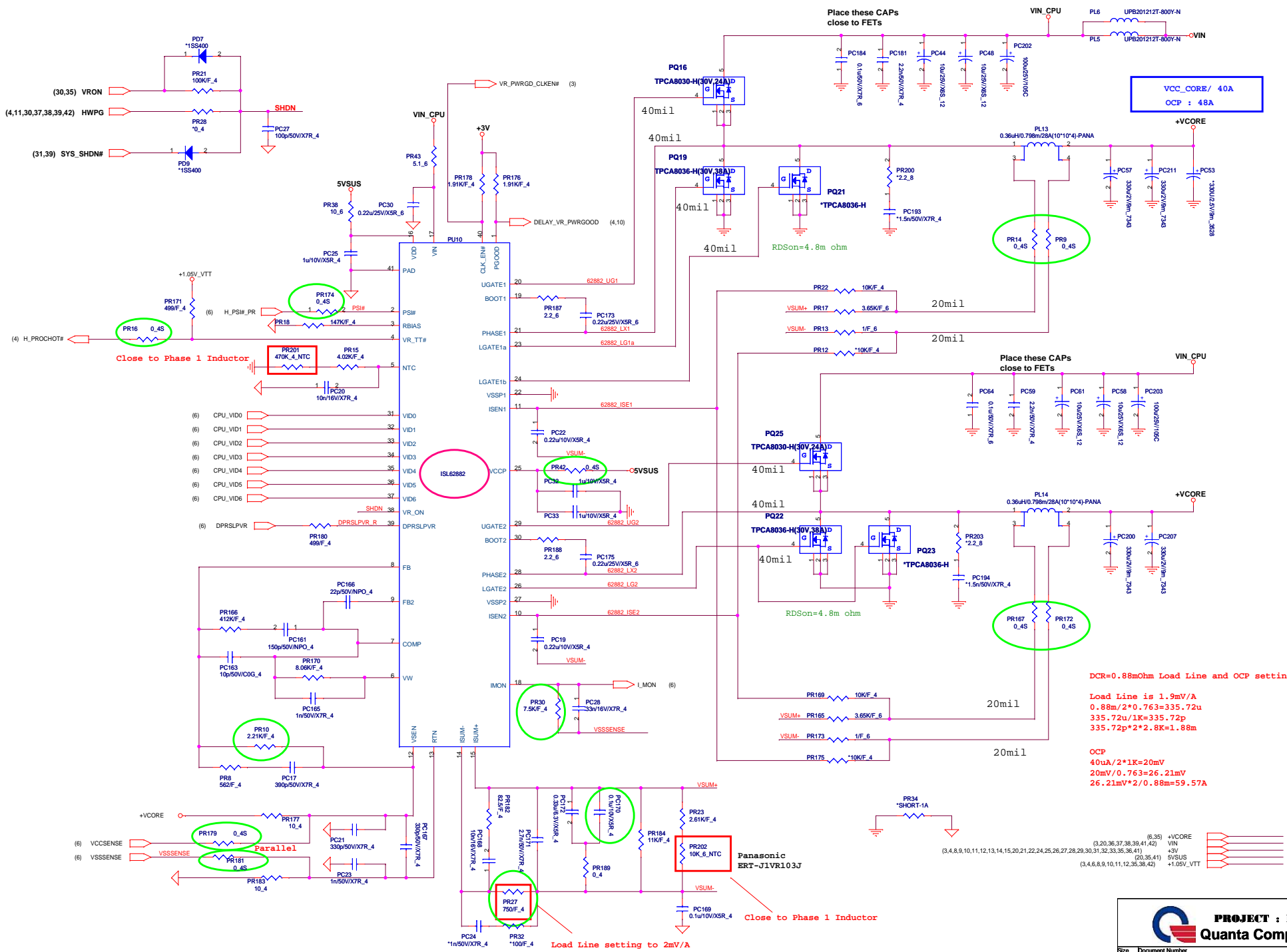

VCC_CORE/ 40A
OCP : 48A

RDson=4.8m ohm

DCR=0.88mOhm Load Line and OCP setting

Load Line is 1.9mV/A
 $0.88m/2 * 0.763 = 335.72\mu$
 $335.72\mu / 1K = 335.72p$
 $335.72p * 2 = 2.8K = 1.88m$

OCP
 $40\mu A / 2 * 1K = 20mV$
 $20mV / 0.763 = 26.21mV$
 $26.21mV * 2 / 0.88m = 59.57A$

- (6,35) +Vcore
- (4,11,30,37,38,39,42) VIN
- (31,39) 5VSUS
- (4) +1.05V_VTT

PROJECT : LL7A
Quanta Computer Inc.

Size C	Document Number	Rev 1A
	CPU (ISL62882)	
Date: Thursday, April 06, 2010	Sheet 40	of 42

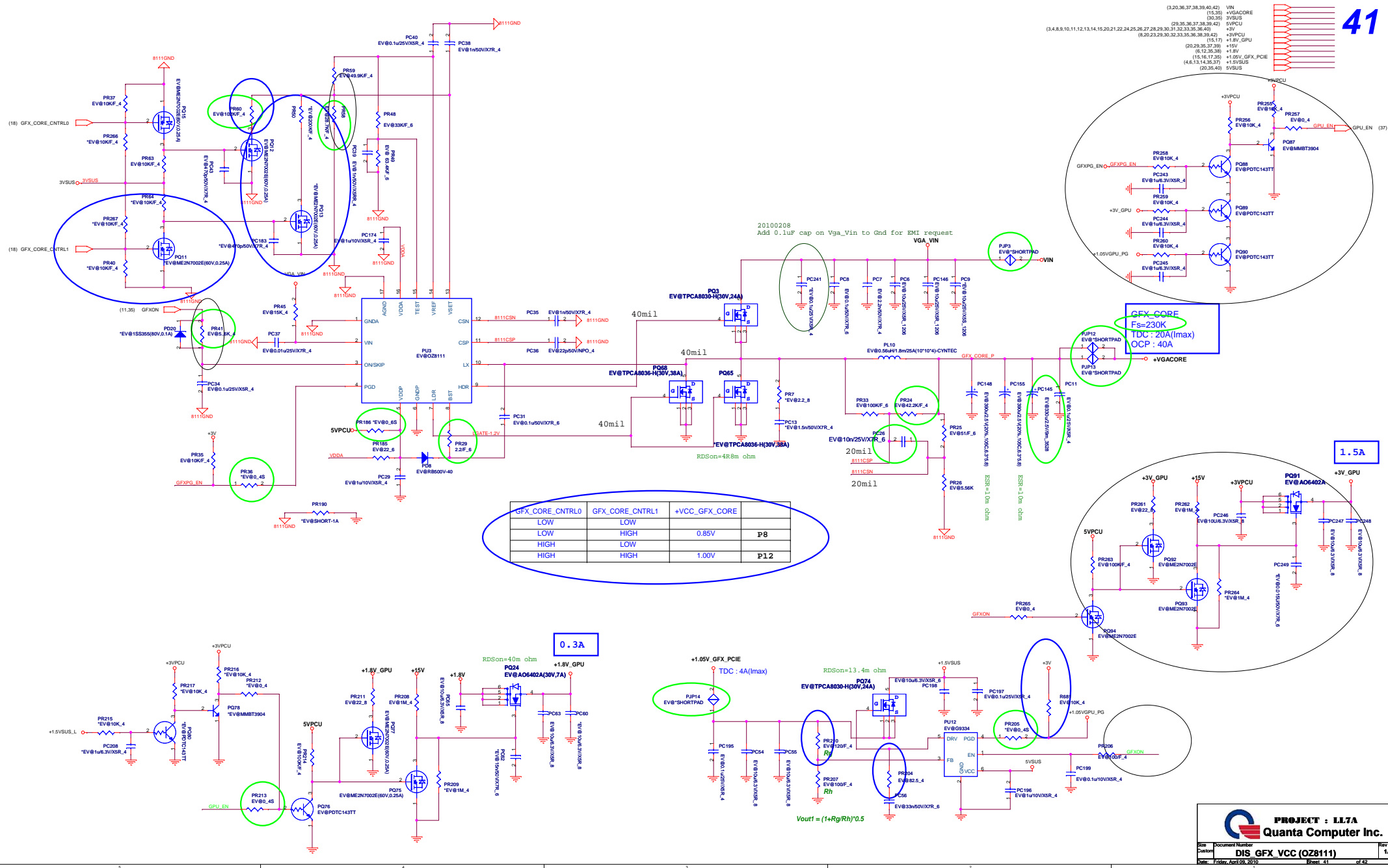

GFX_CORE_CNTRL0	GFX_CORE_CNTRL1	+VCC_GFX_CORE	
LOW	LOW	0.85V	P8
LOW	HIGH	0.85V	P8
HIGH	LOW	1.00V	P12
HIGH	HIGH	1.00V	P12

GFX_CORE
 F_s=230K
 TDC: 20A(Max)
 OCP: 40A

1.5A

0.3A

+1.05V GFX_PCIE
 TDC: 4A(Max)

$V_{out} = (1+R_g/R_h) \cdot 0.5$

PROJECT : LL7A
QUANTA Computer Inc.

Size: Custom Document Number: DIS GFX_VCC (OZ8111) Rev: 1A
 Date: Friday, April 09, 2010 Sheet: 41 of 42

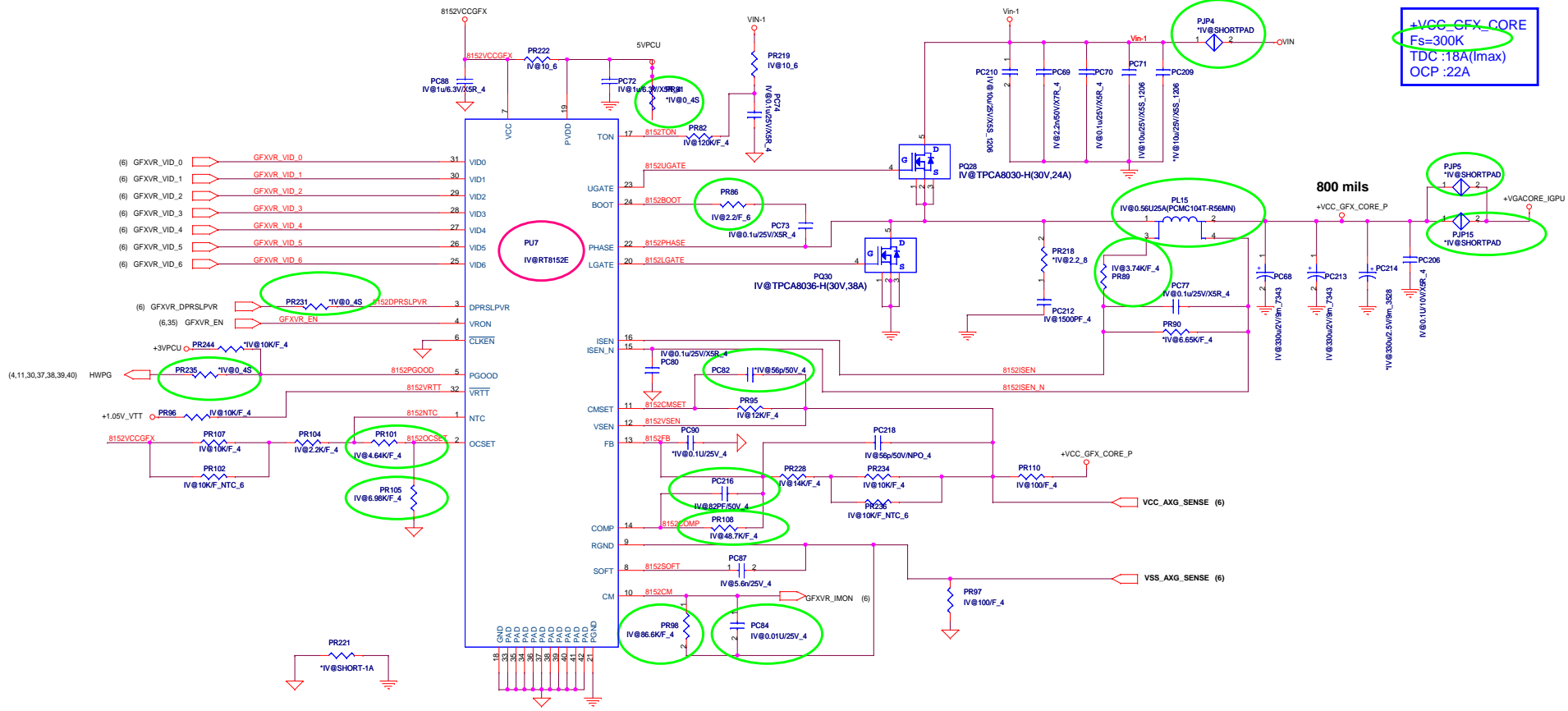

+VCC_GFX_CORE
Fs=300K
TDC:18A(I_{max})
OCP:22A

800 mils

- (6) GFXVR_VID_0 >> GFXVR_VID_0 31 VID0
- (6) GFXVR_VID_1 >> GFXVR_VID_1 30 VID1
- (6) GFXVR_VID_2 >> GFXVR_VID_2 29 VID2
- (6) GFXVR_VID_3 >> GFXVR_VID_3 28 VID3
- (6) GFXVR_VID_4 >> GFXVR_VID_4 27 VID4
- (6) GFXVR_VID_5 >> GFXVR_VID_5 26 VID5
- (6) GFXVR_VID_6 >> GFXVR_VID_6 25 VID6

- (6) GFXVR_DPRSPLVR >> 8152DPRSPLVR 3 DPRSPLVR
- (6,35) GFXVR_EN >> GFXVR_EN 4 VRON

- (4,11,30,37,38,39,40) HWPG >> 8152PGOOD 5 PGOOD
- >> 8152VRTT 32 VRTT

- +1.05V_VTT >> 8152NTC 1 NTC
- >> OCSET 2 OCSET

- CMSET >> 8152CMSET 2 OCSET
- VSEN >> 8152VSEN 12 VSEN
- FB >> 8152FB 13 FB

- COMP >> 8152CMP 14 COMP
- RGND >> 8152SOFT 8 SOFT
- SOFT >> 8152SOFT 8 SOFT
- CM >> 8152CM 10 CM

- (6,35) +VGACORE_IGPU >>>>>
- (3,20,36,37,38,39,40,41) VIN >>>>>
- (29,35,36,37,38,39,41) 5VPCU >>>>>
- (3,4,6,8,9,10,11,12,35,38,40) +1.05V_VTT >>>>>
- (8,20,23,29,30,32,33,35,36,38,39,41) +5VPCU >>>>>

PROJECT : LL7A
Quanta Computer Inc.

Size C	Document Number	Rev 1A
	GFX_VCC (RT8152C)	
Date:	Thursday, April 06, 2010	Sheet 42 of 42