

BLOCK DIAGRAM

BLOCK DIAGRAM

X553MA SCHEMATIC

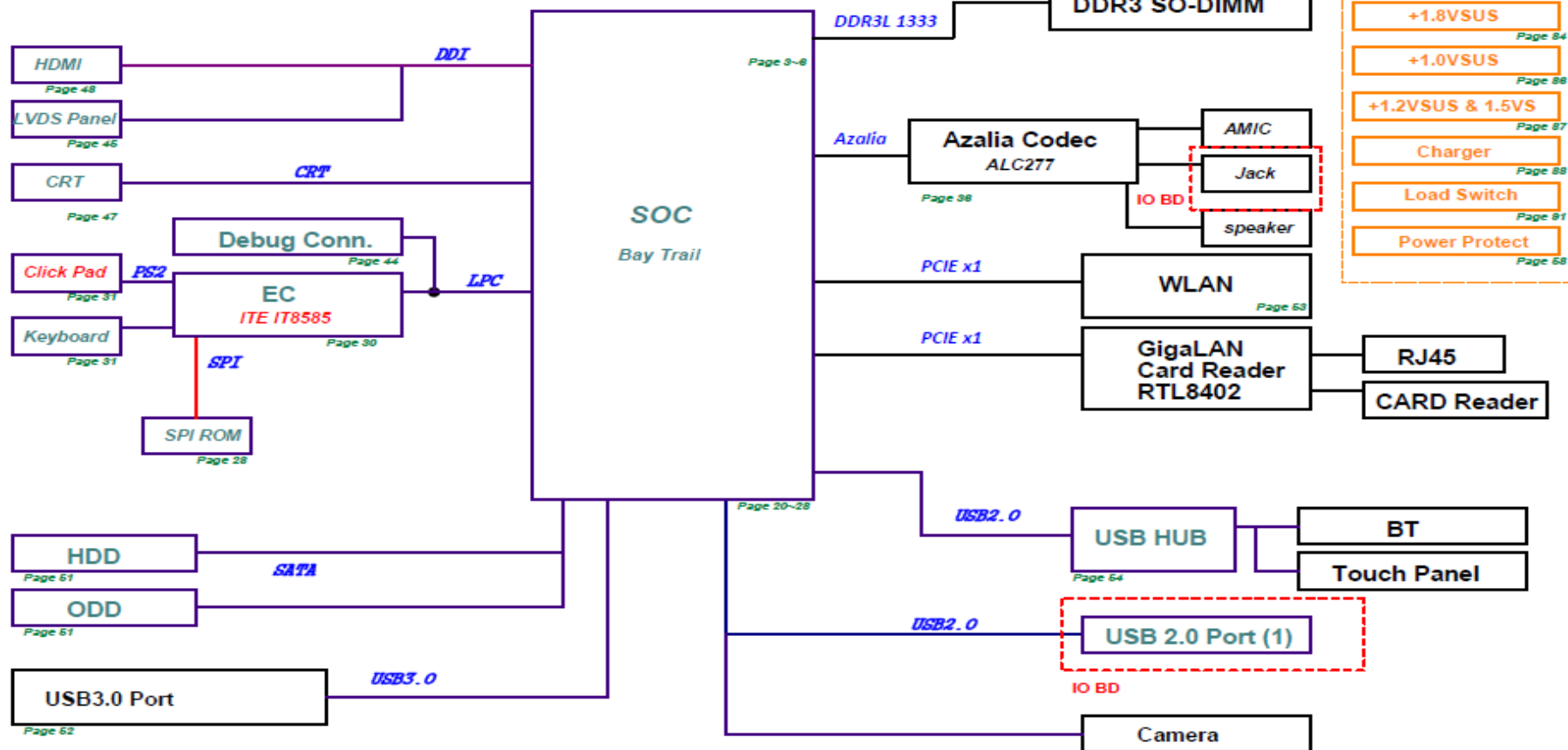

POWER FLOW

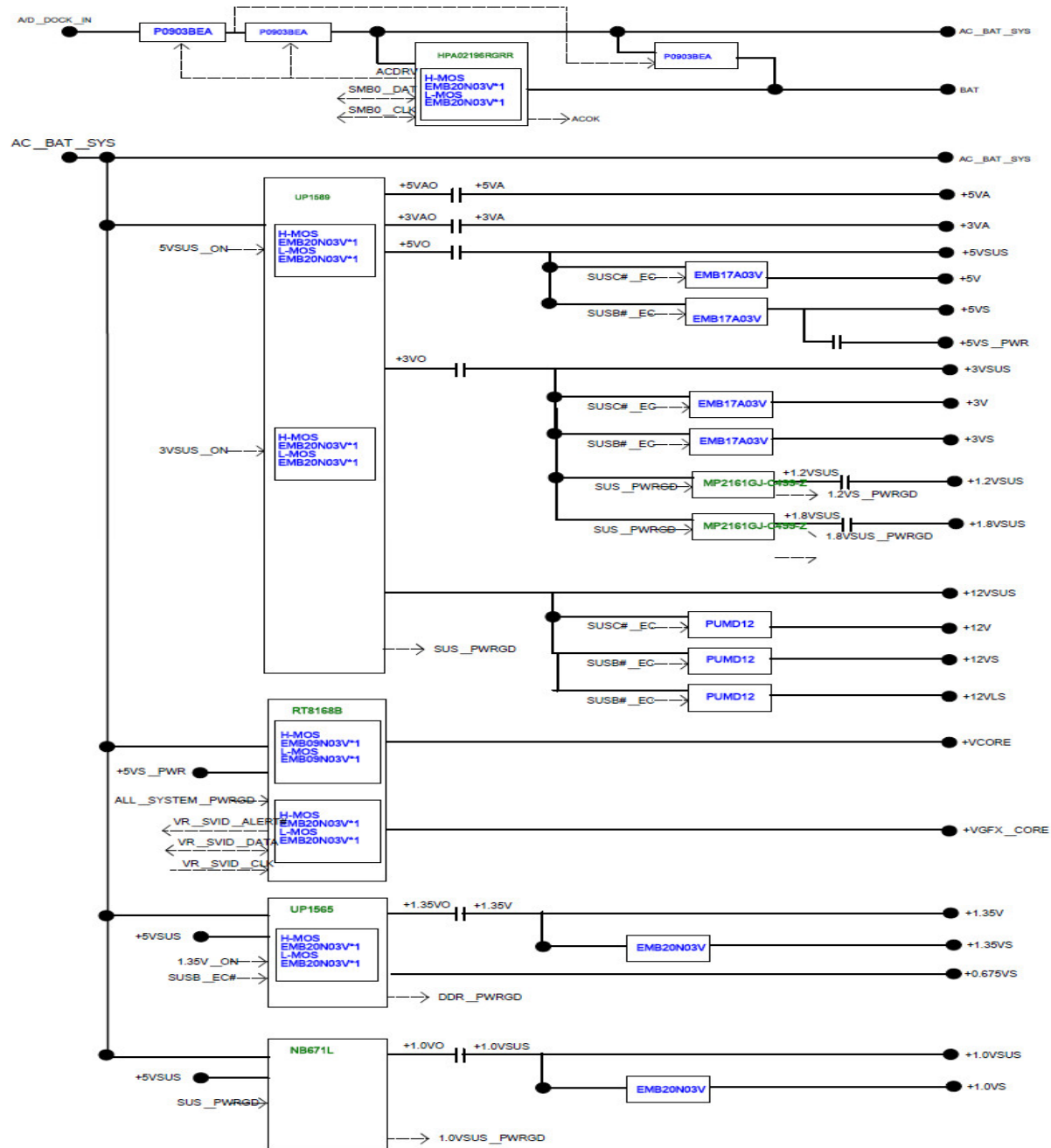

POWER ON SEQUENCE

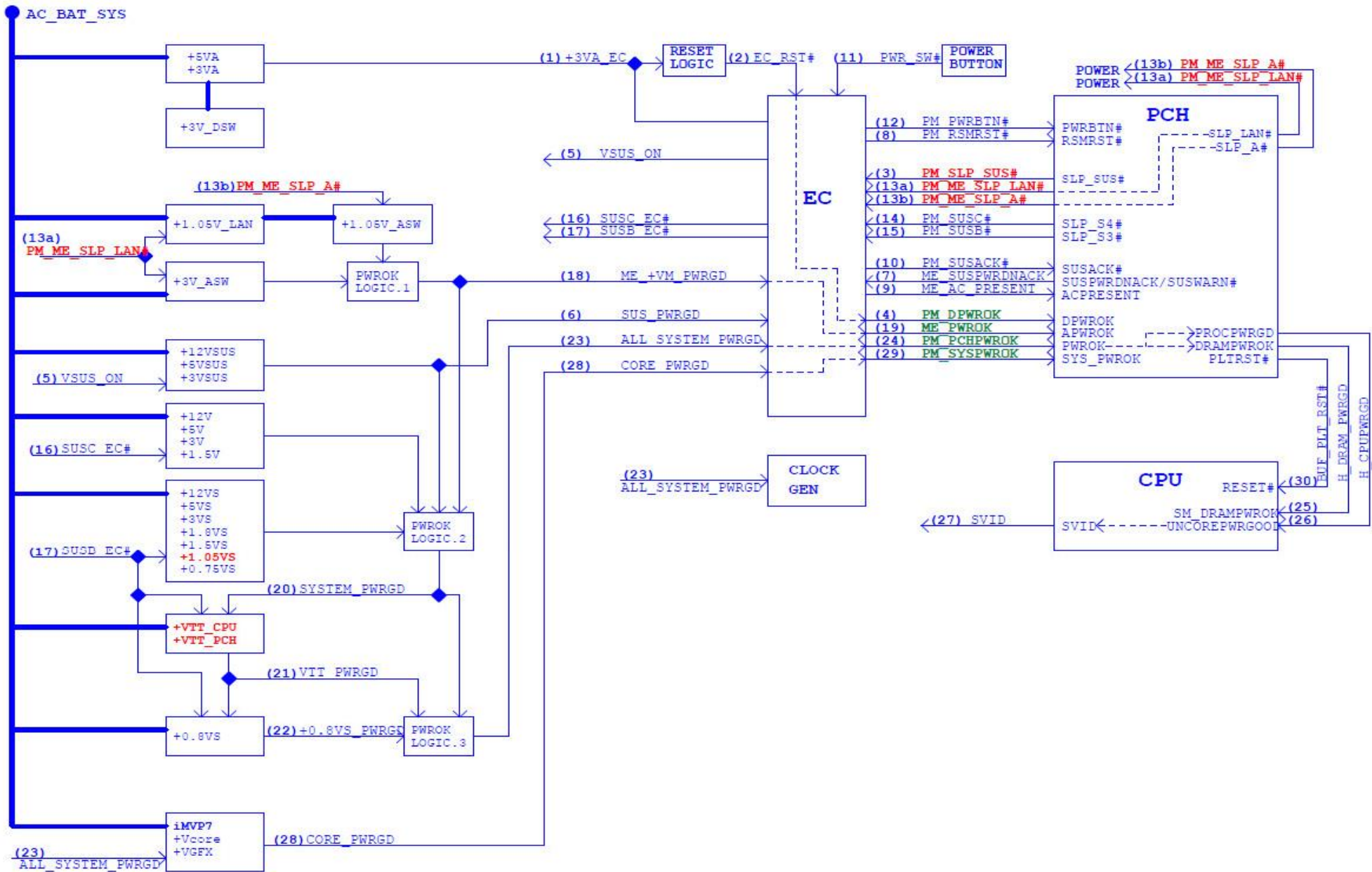

POWER ON SEQUENCE(AC Mode)

AC-IN Mode

U53 Power-On Sequence
Timing Diagram Rev.0.14

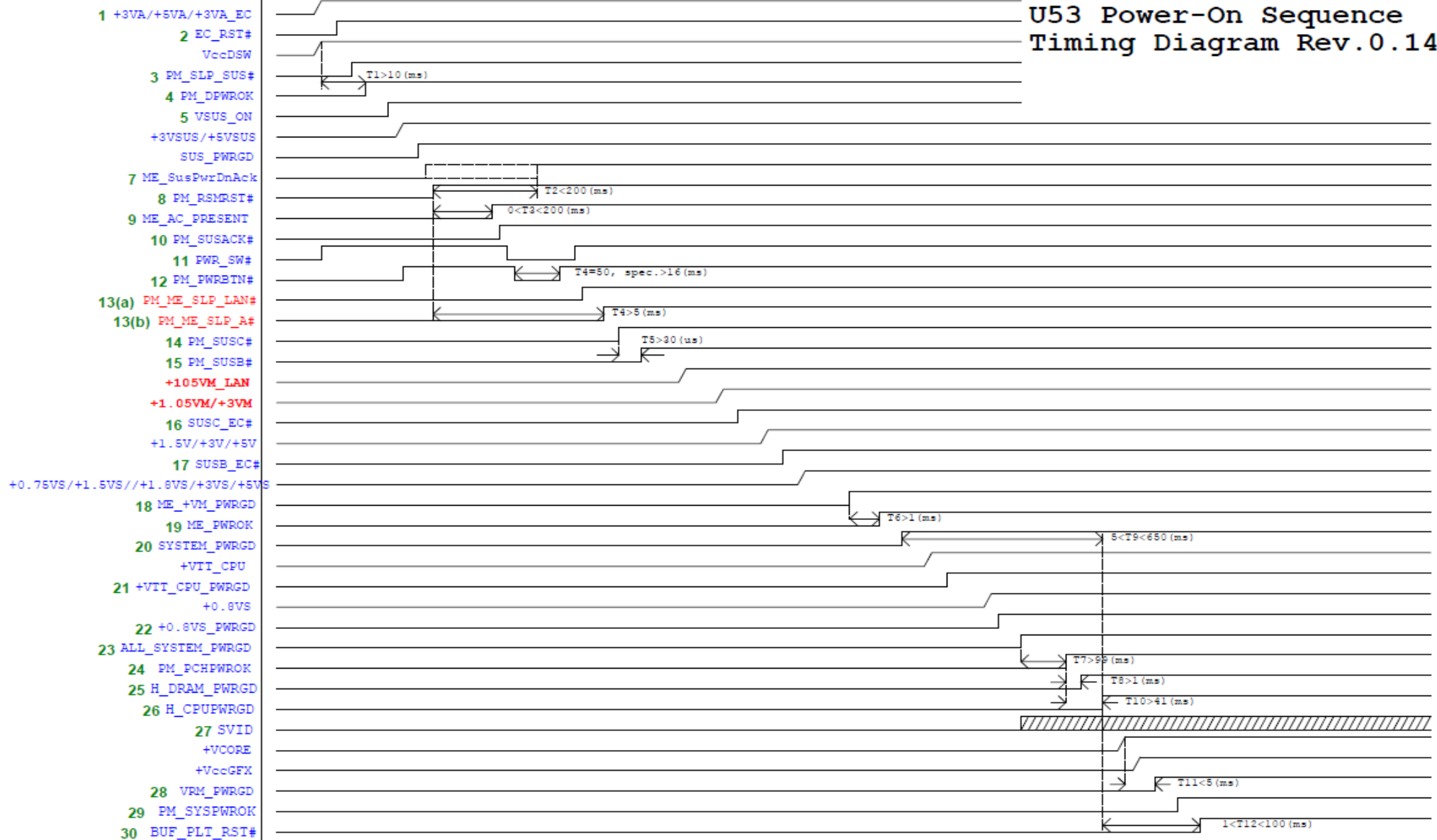

POWER ON SEQUENCE(DC Mode)

DC-IN Mode

U53 Power-On Sequence
Timing Diagram Rev.0.14

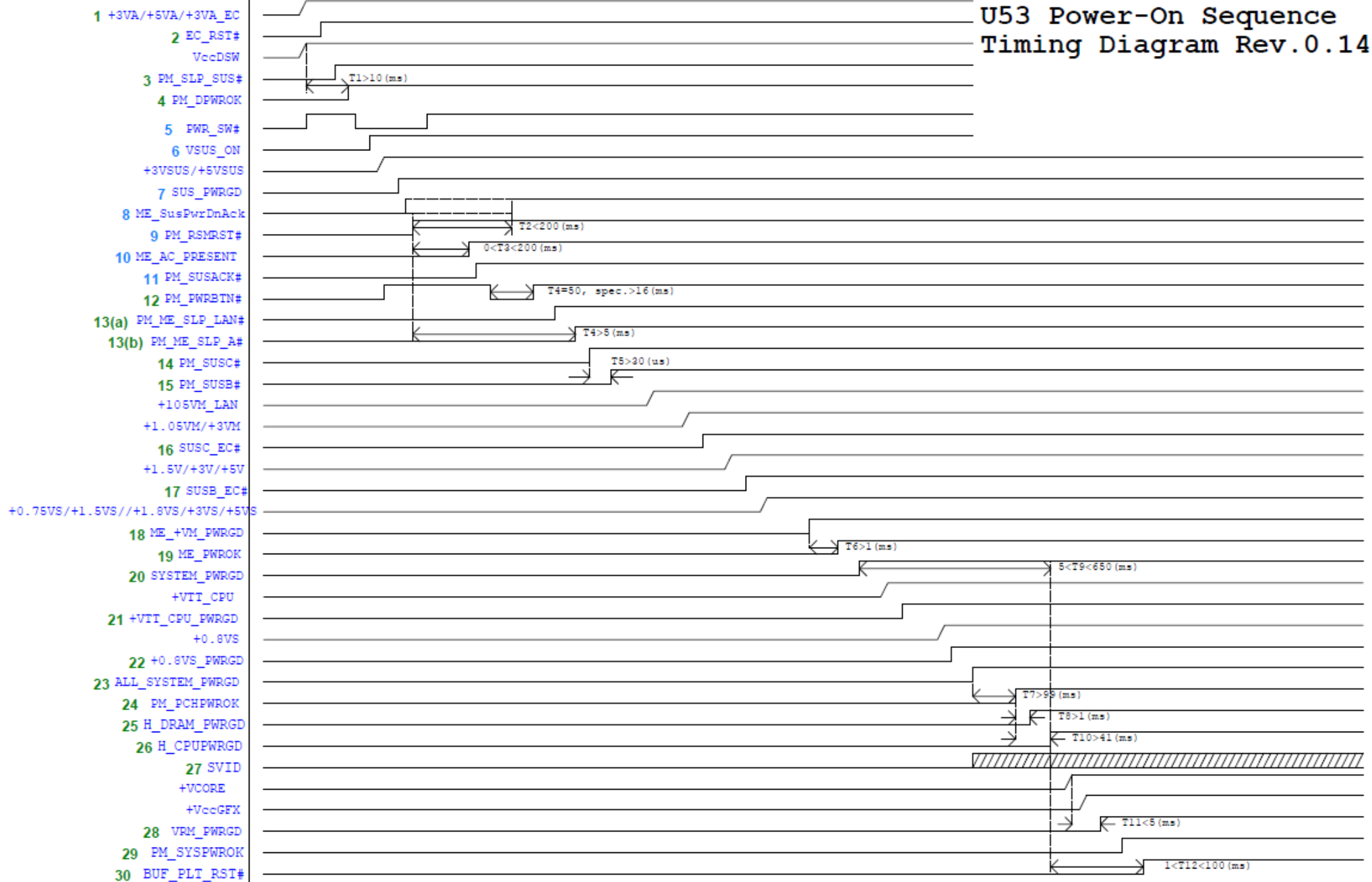

Signal Measure Point-Bottom

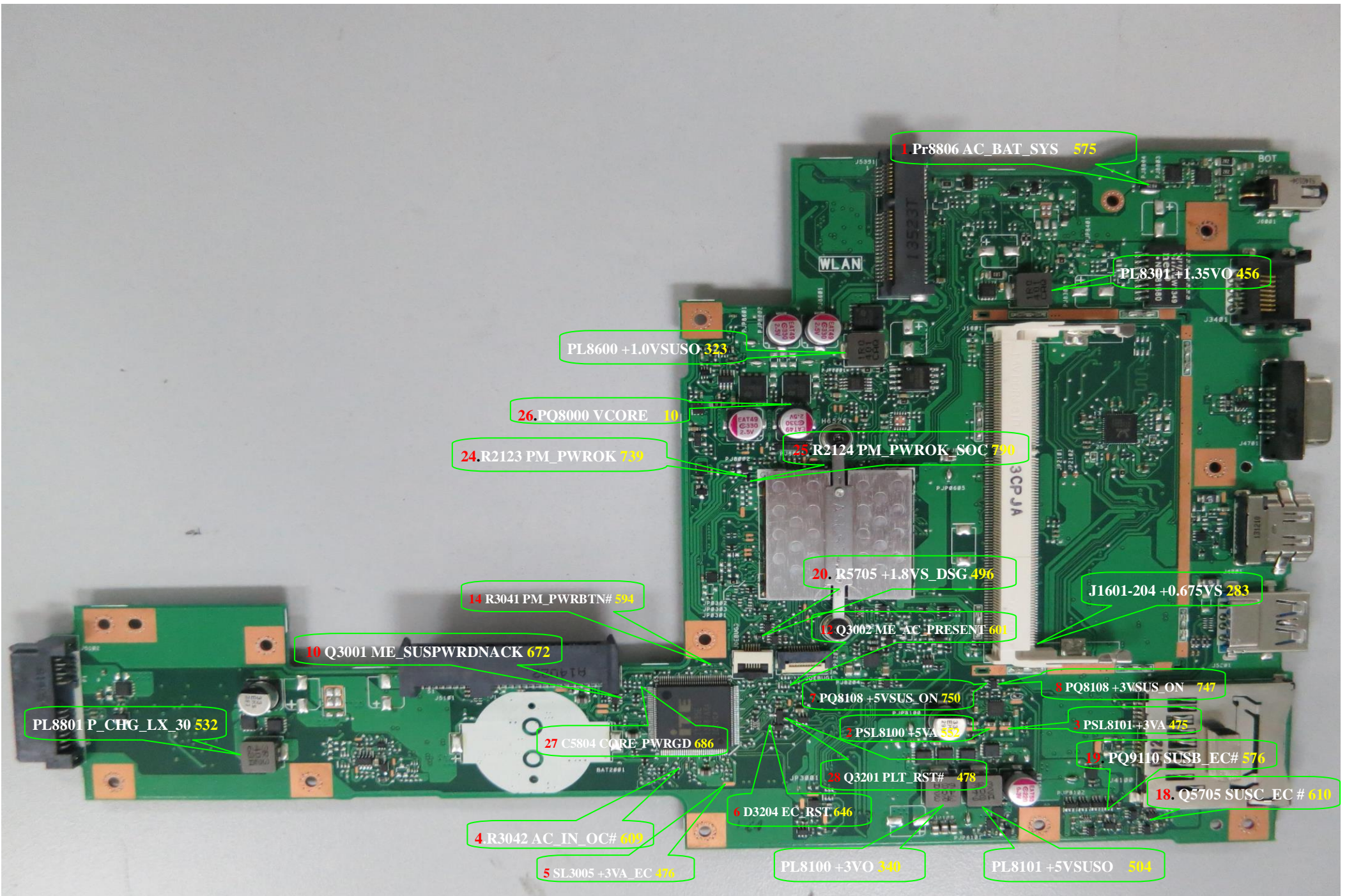

Signal Measure Point-Top

