

(15")

Villemont 2010

Montevina (Intel-Discrete)

DDR3-MV Build (A01)

2010.03.02

DATE	CHANGE NO.	REV

DRAWER	EE	DATE	POWER	DATE	INVENTEC			
DESIGN					TITLE Villemont Intel Discrete			
CHECK								
RESPONSIBLE								
SIZE =	3			VER :	SIZE A3	CODE CS	DOC NUMBER 1310A23644-0-MTR	REV A01
FILE NAME :	XXXX XXXXXX-XX				SHEET	1	OF	70
P/N	XXXXXXXXXXXX							

Table Of Contents

Page	Page	Page
5- DC & Battery Charger & OCP.	15- Clock Generator.	39- Keyboard & TouchPad CONN.
6- Select & Battery CONN.	16- CPU Penryn-1.	40- HDD & ODD CONN.
7- System Power (+V3A/+V5A).	17- CPU Penryn-2.	41- USB CONN.
8- System Power (+V1.5/+VCCP) .	18- CPU Penryn-3.	42- Audio CODEC.
9- Graphic Power (+VDD_CORE & +VPCIE).	19- CPU Penryn-4 & XDP.	43- Speaker & MIC AUDIO CONN MB SIDE.
10- System Power (+V1.8S) .	20- Thermal & Fan.	44- BLANK.
11- CPU Power (+VCC_CORE).	21- N/B Cantiga-1.	45- MDC CONN.
12- DDR Termination Voltage(+V0.75S).	22- N/B Cantiga-2.	46- NIC 10/100 LAN CONN.
13- Power (Sleep: +V5S/+V3S/+V1.5S).	23- N/B Cantiga-3.	47- NIC 10/100 & RJ45 CONN.
14- Power (Sequence).	24- N/B Cantiga-4.	48- Mini Card(WLAN) CONN.
	25- N/B Cantiga-5.	49- Bluetooth CONN.
	26- N/B Cantiga-6.	50- Express Card.
	27- DDR3-DIMM0.	51- BLANK
	28- DDR3-DIMM1.	52- HDMI CONN.
	29- BLANK.	53- Switch CONN & LED.
	30- CRT CONN.	54- EMI CAP.
	31- LCD & WebCam CONN.	55- Screws.
	32- S/B ICH9-1.	56- Crack testing circuit.
	33- S/B ICH9-2.	57- AMD M93LP-1.
	34- S/B ICH9-3.	58- AMD M93LP-2.
	35- S/B ICH9-4.	59- AMD M93LP-3.
	36- S/B ICH9-5.	60- AMD M93LP-4.
	37- KBC.	61- Video RAM-1 (DDR3).
	38- SPI.	62- Video RAM-2 (DDR3).
		63- CardRead SD/MMC Board.
65- Power button & LID swithch Board.	69- 15''HDD Extend Board.	64- Headphone JACK & MIC JACK Board.
66- BLANK	70- 15''ODD Extend Board.	
67- USB Right side Board.		
68- PICK Button Board.		

INVENTEC			
TITLE <i>Villemont Intel Discrete Contents</i>			
SIZE A3	CODE CS	DOC NUMBER <i>1310A23644-0-MTR</i>	REV A01
CHANGE by <i>Jimmy song</i>		9-Feb-2010	
SHEET		2	OF 70

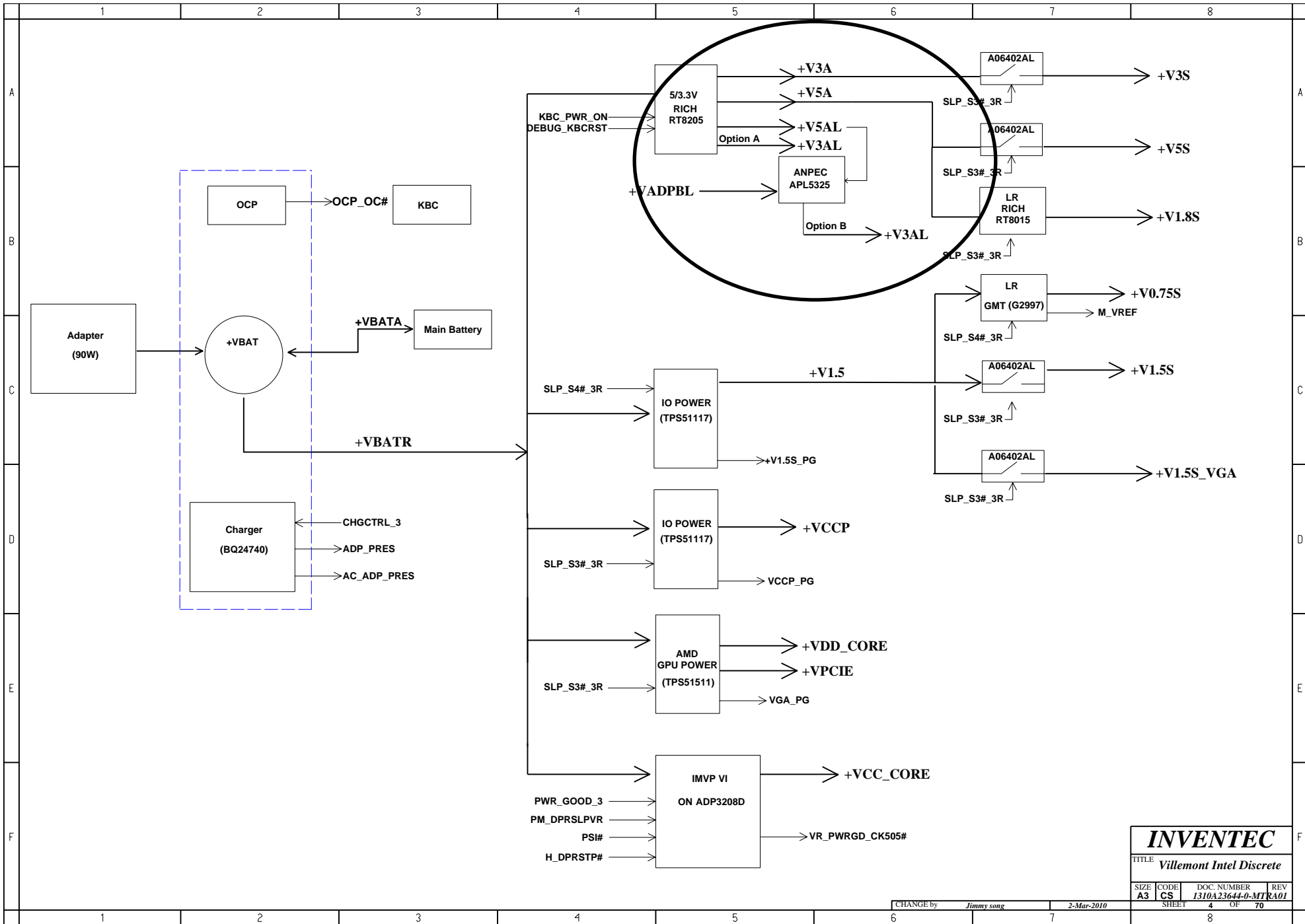

INVENTEC			
TITLE Villemont Intel Discrete			
SIZE A3	CODE CS	DOC. NUMBER 1310A23644-0-MTR	REV A01
CHANGE by Jimmy song		2-Mar-2010	
SHEET 4		OF 70	

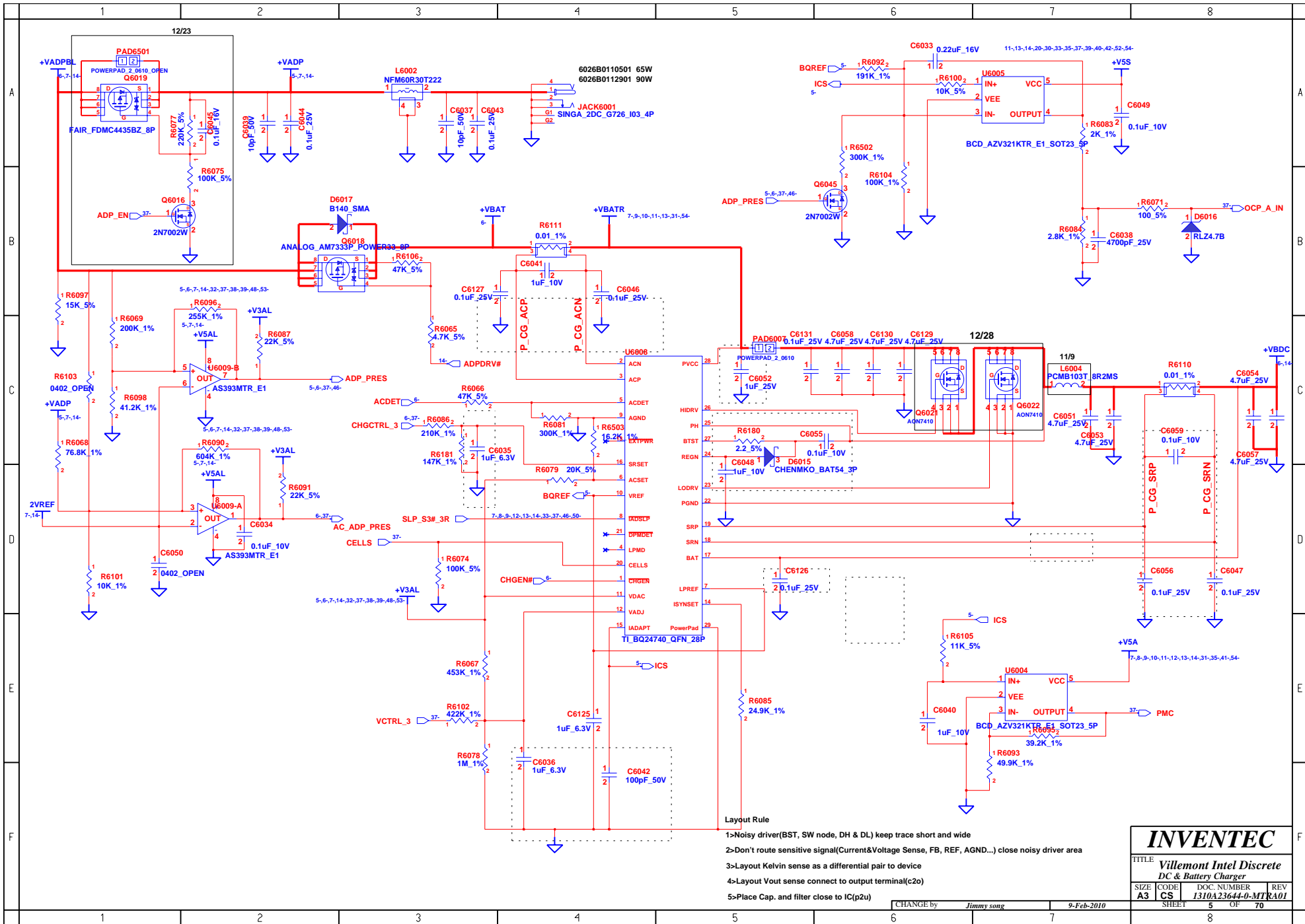

- Layout Rule
- 1>Noisy driver(BST, SW node, DH & DL) keep trace short and wide
 - 2>Don't route sensitive signal(Current&Voltage Sense, FB, REF, AGND...) close noisy driver area
 - 3>Layout Kelvin sense as a differential pair to device
 - 4>Layout Vout sense connect to output terminal(c2o)
 - 5>Place Cap. and filter close to IC(p2u)

INVENTEC			
TITLE Villemont Intel Discrete DC & Battery Charger			
SIZE	CODE	DOC NUMBER	REV
A3	CS	I310A23644-0-MTR	RA01
SHEET		OF	
5		70	

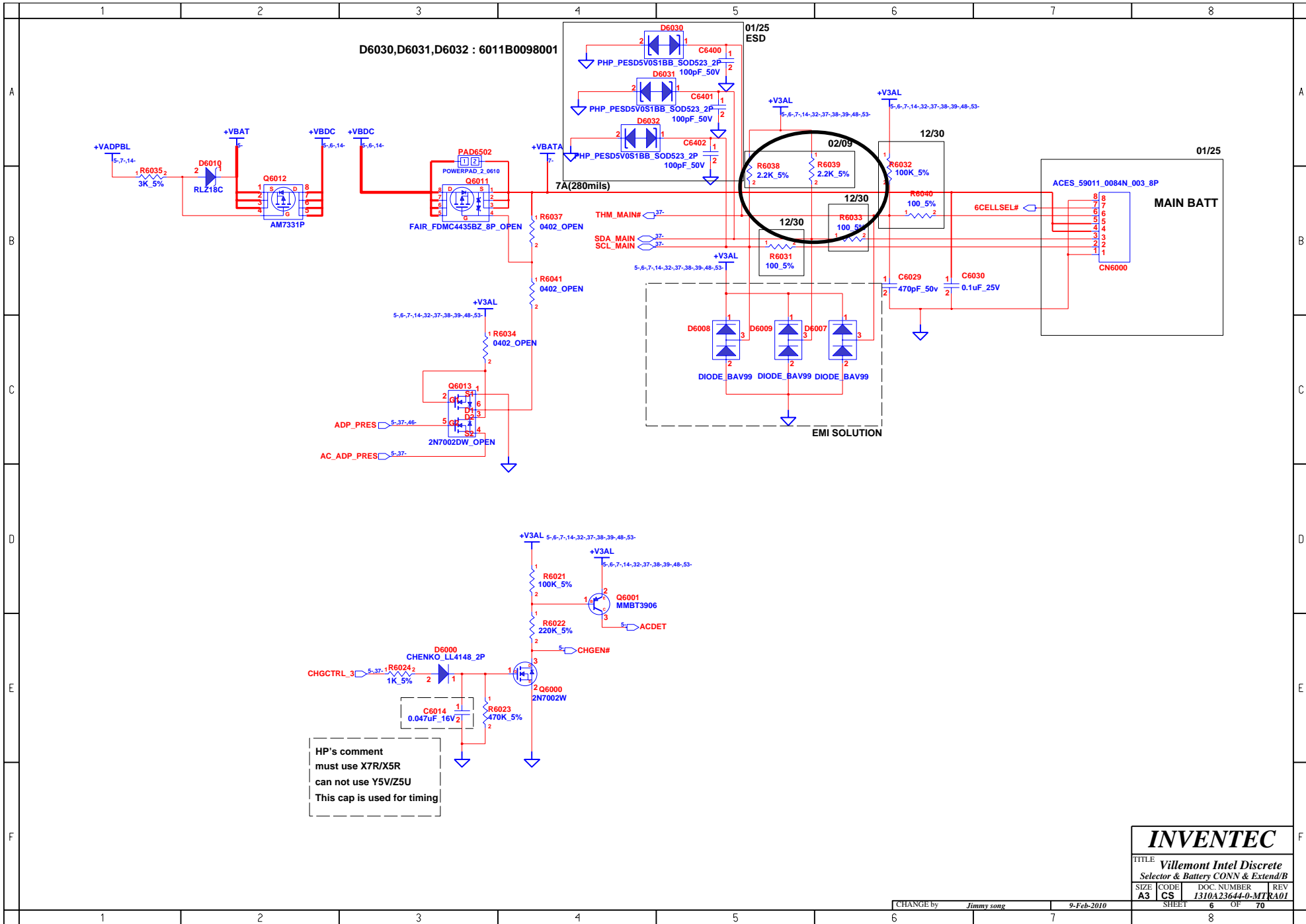

INVENTEC			
TITLE Villemont Intel Discrete			
Selector & Battery CONN & Extend/B			
SIZE	CODE	DOC NUMBER	REV
A3	CS	1310A23644-0-MT	RA01
CHANGE by <i>Jimmy song</i>		9-Feb-2010	
SHEET 6		OF 70	

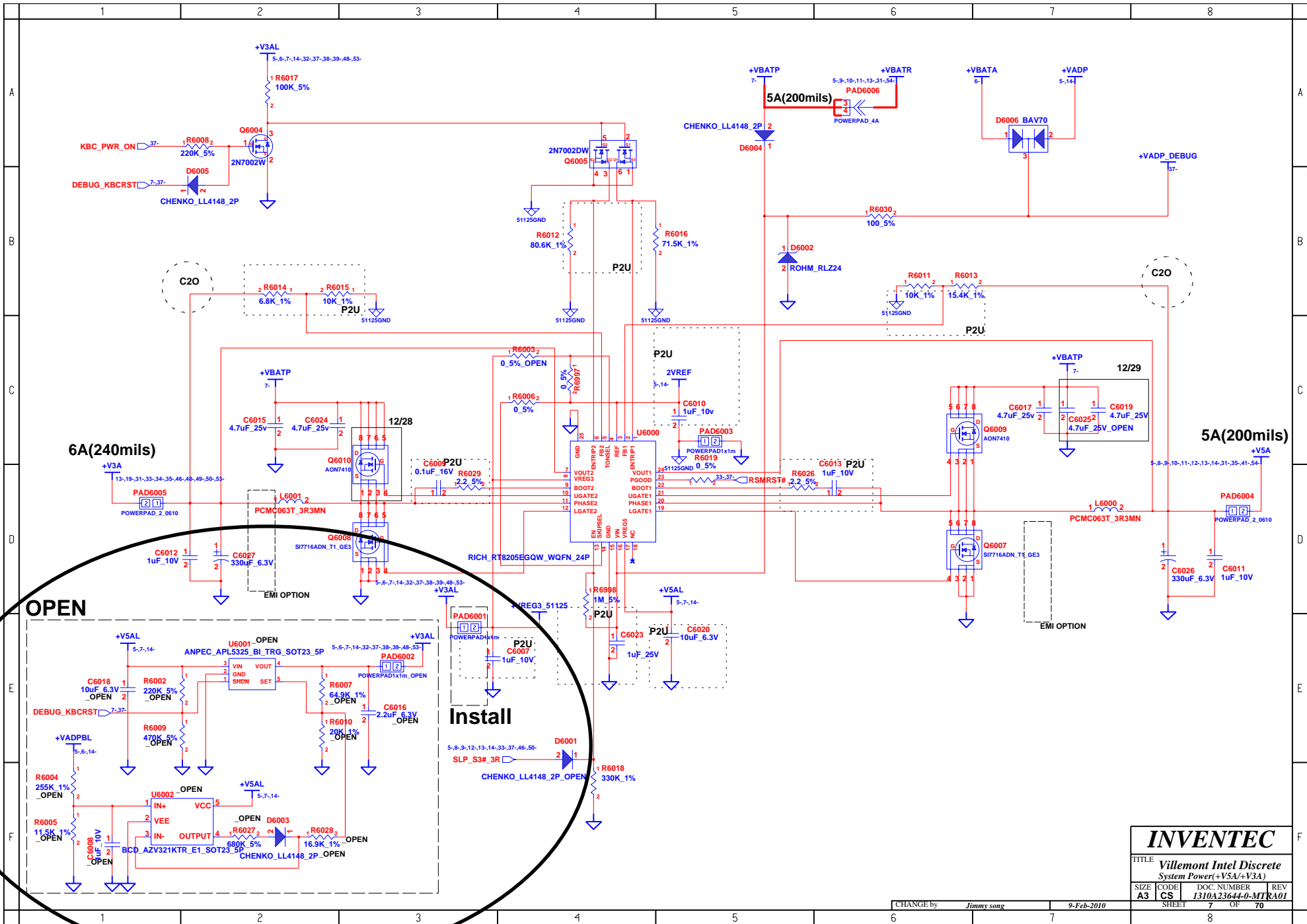

INVENTEC			
TITLE: Villemont Intel Discrete System Power(+V5A/+V3A)			
SIZE: A3	CODE: CS	DOC NUMBER: I310A23644-0-MT	REV: RA01
CHANGE by: Jimmy song		9-Feb-2010	
SHEET: 7		OF: 70	

<http://sualaptop365.com.vn/mafix.vn>

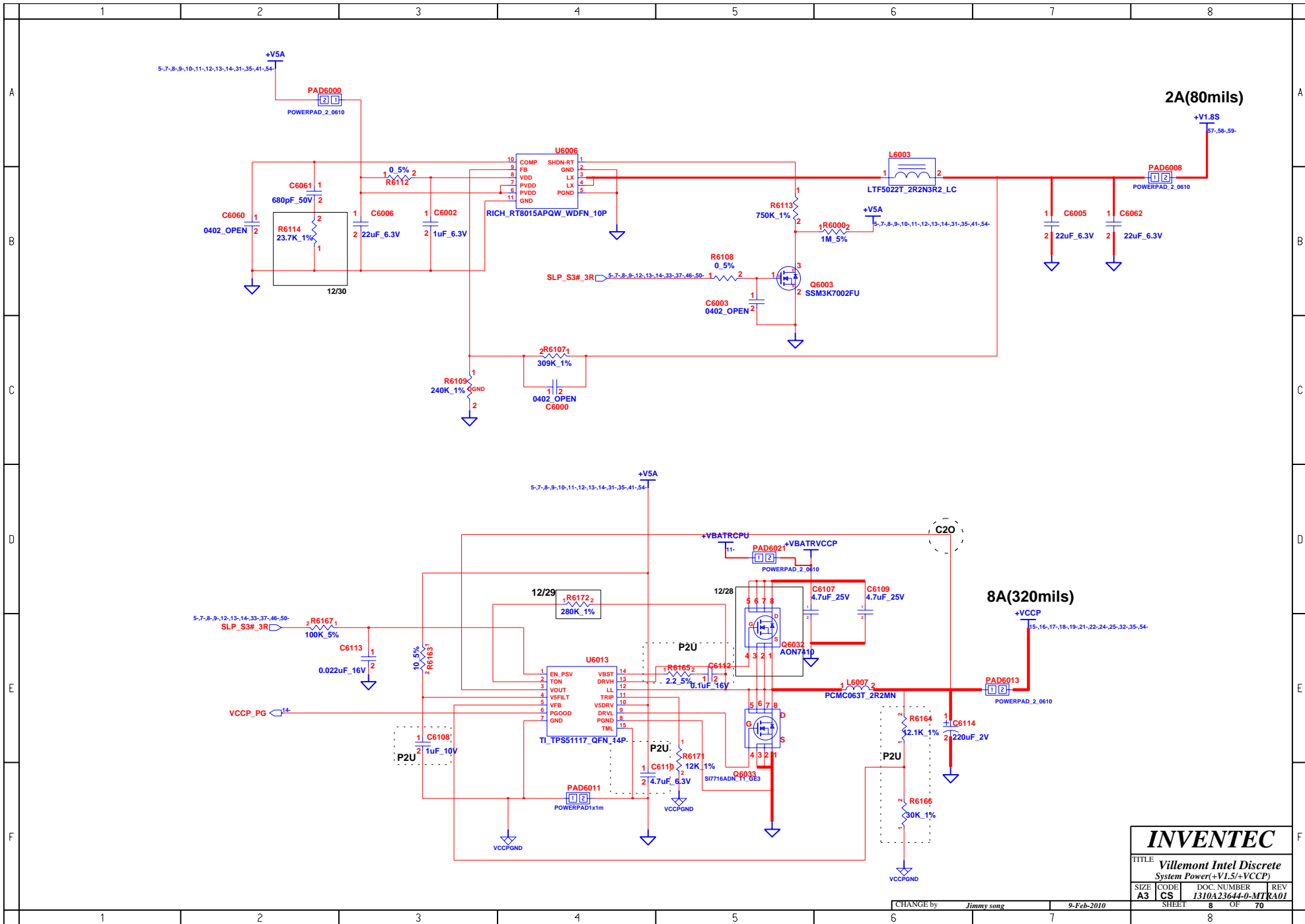

INVENTEC			
TITLE <i>Villemont Intel Discrete</i>			
System Power(+V1.5/+VCCP)			
SIZE	CODE	DOC NUMBER	REV
A3	CS	1310A23644-0-MT	KA01
CHANGE by <i>Jimmy song</i>		9-Feb-2010	
SHEET 8		OF 70	

<http://sualaptop365.edu.vn/mafix.vn>

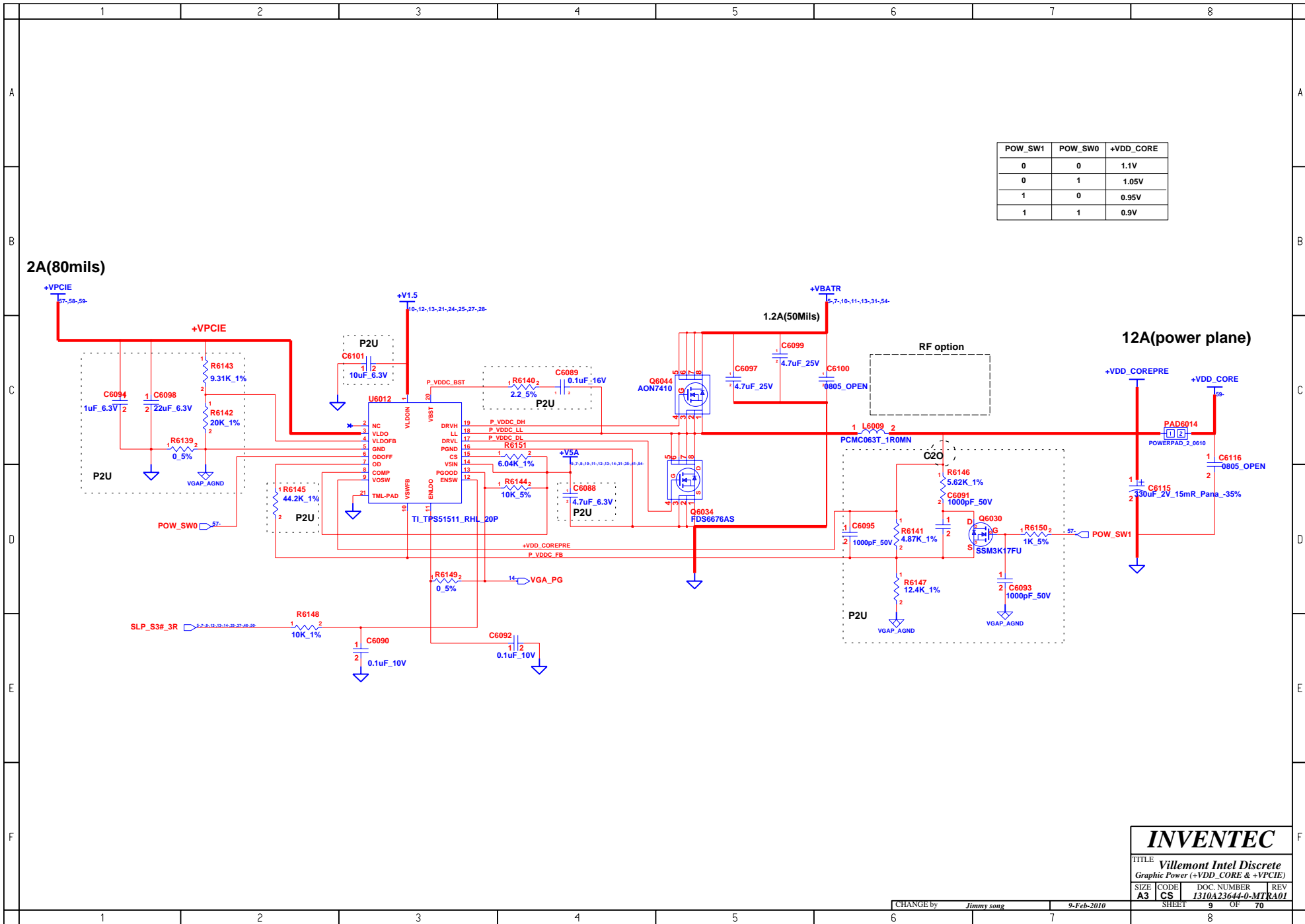

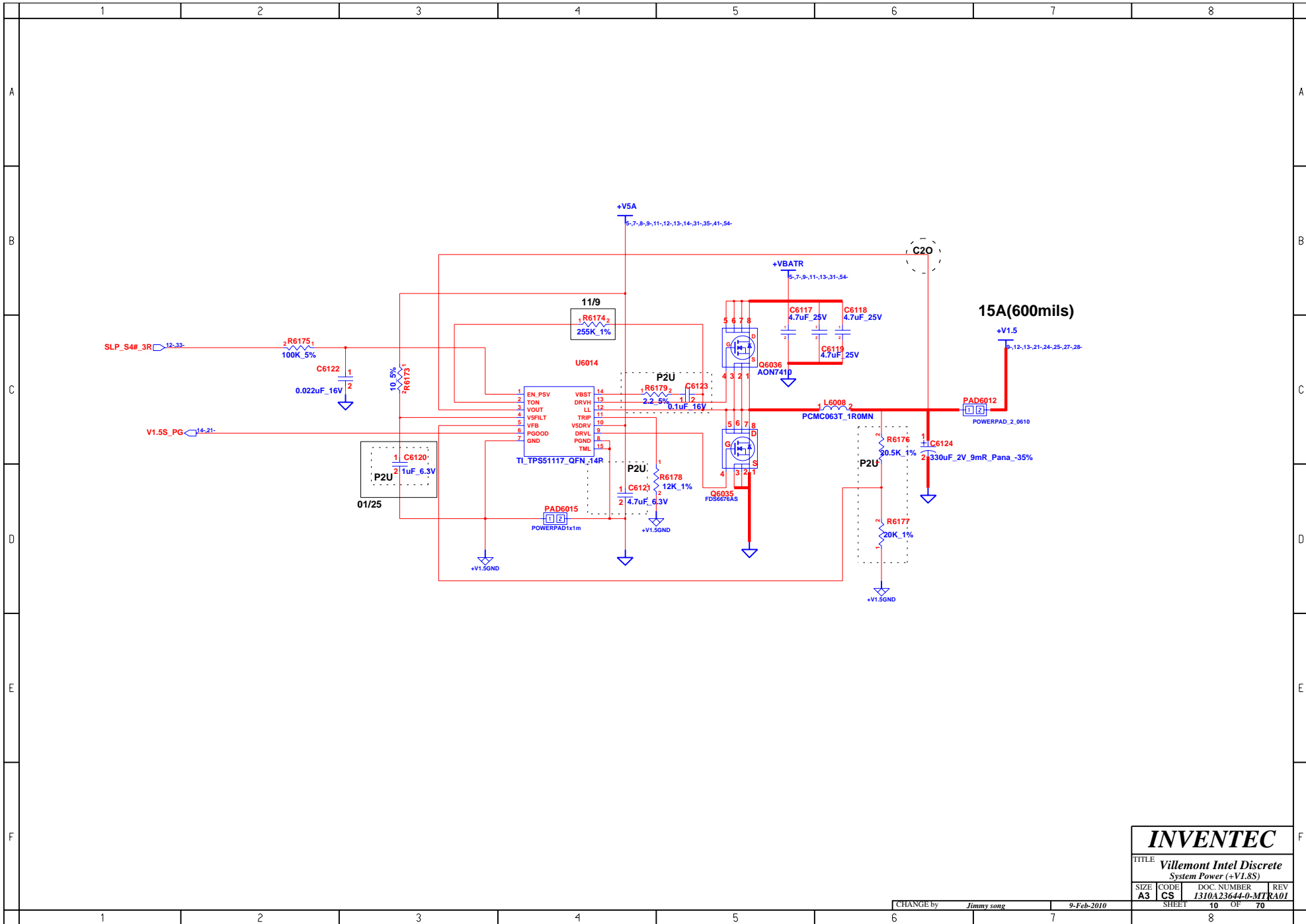

INVENTEC			
TITLE Villemont Intel Discrete System Power (+V1.8S)			
SIZE A3	CODE CS	DOC. NUMBER 1310A23644-0-MTR	REV KA01
CHANGE by <i>Jimmy song</i>		9-Feb-2010	
SHEET 10		OF 70	

<http://sualaptop365.edu.vn>
www.vinafix.vn

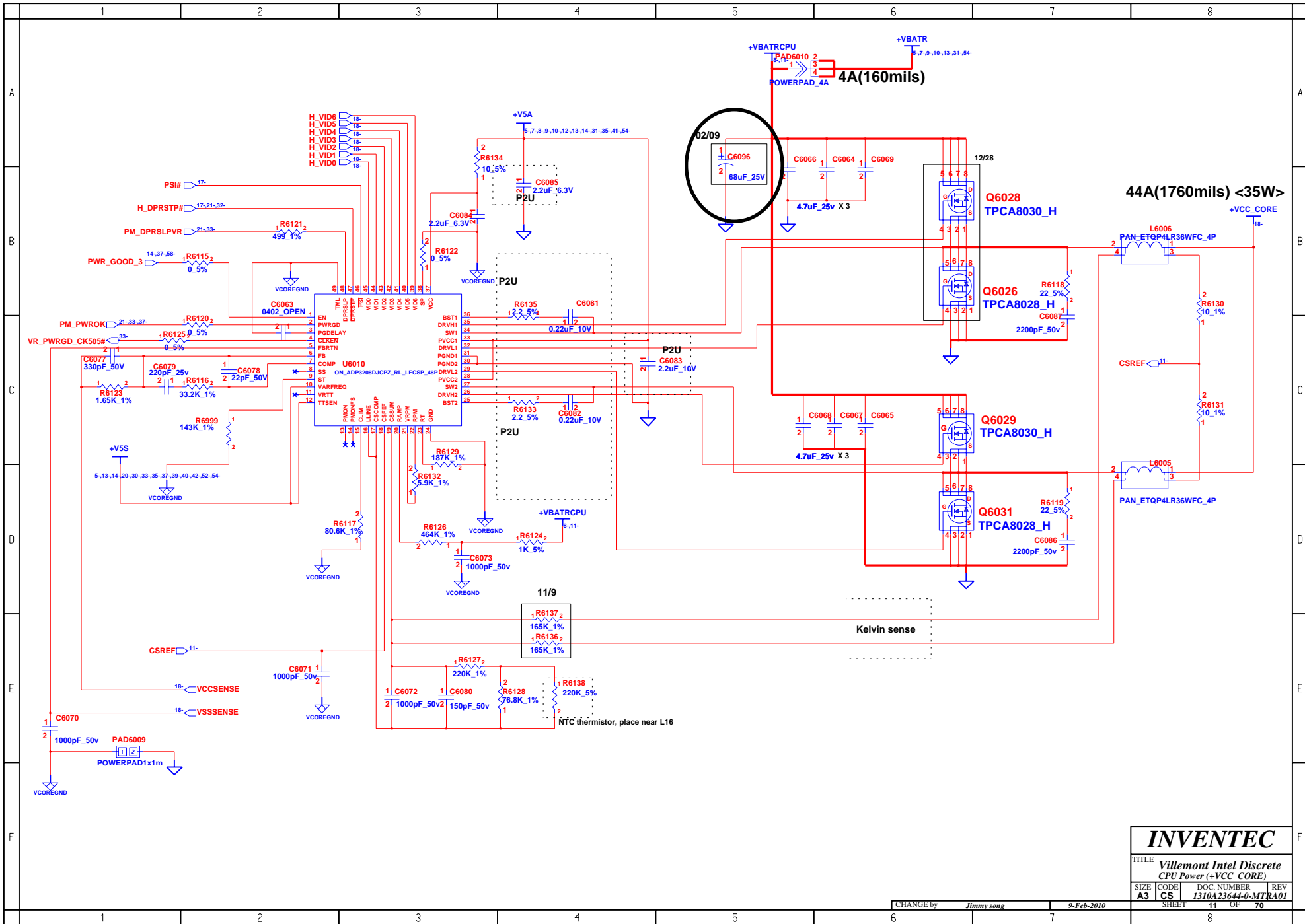

INVENTEC			
TITLE Villemont Intel Discrete CPU Power (+VCC_CORE)			
SIZE A3	CODE CS	DOC. NUMBER I310A23644-0-MT	REV A01
CHANGE by Jimmy song		9-Feb-2010	
SHEET 11		OF 70	

<http://sualaptop365.com>
www.vimafix.vn

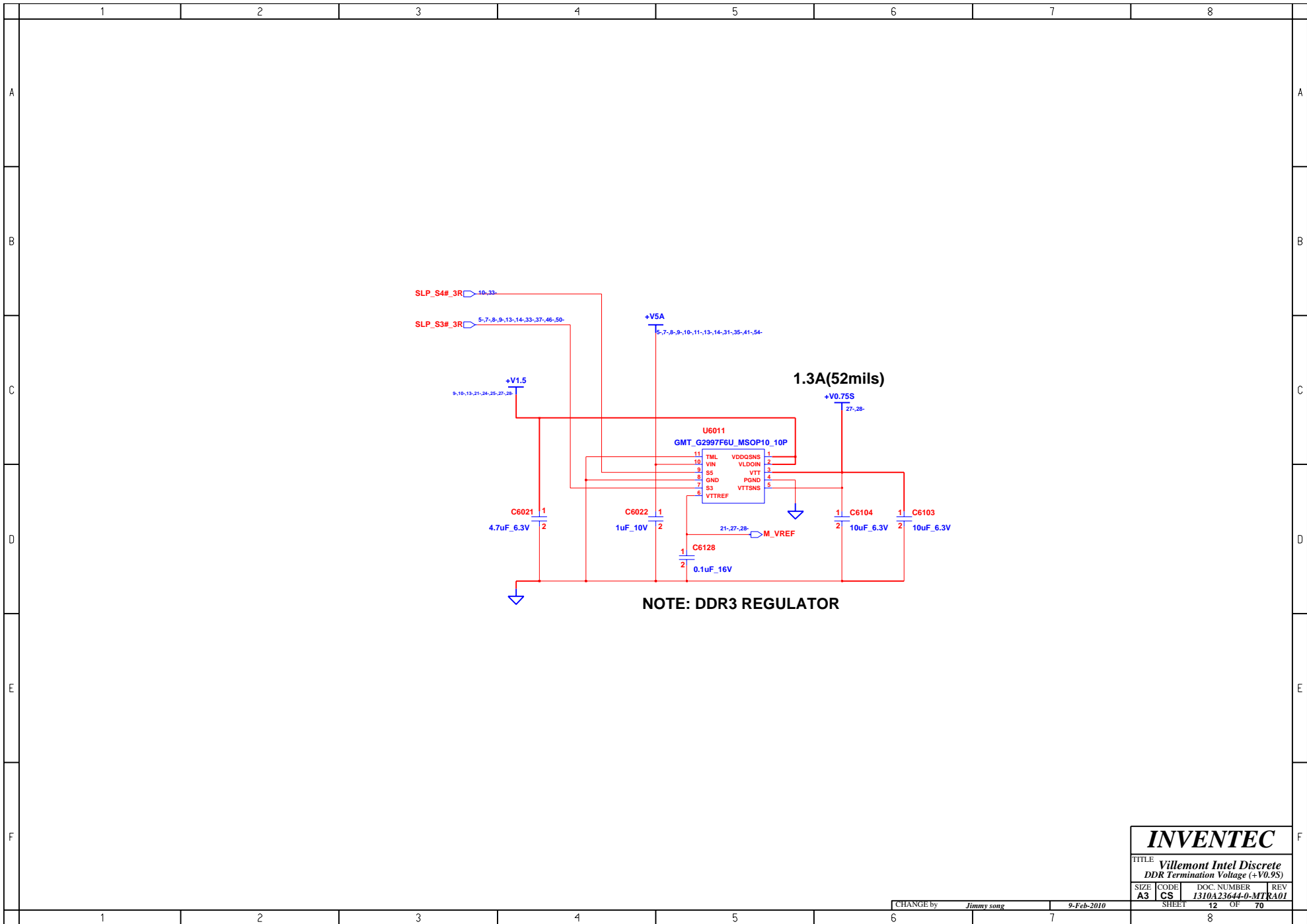

INVENTEC			
TITLE Villemont Intel Discrete			
DDR Termination Voltage (+V0.9S)			
SIZE	CODE	DOC. NUMBER	REV
A3	CS	1310A23644-0-MT	RA01
CHANGE by <i>Jimmy song</i>		9-Feb-2010	SHEET 12 OF 70

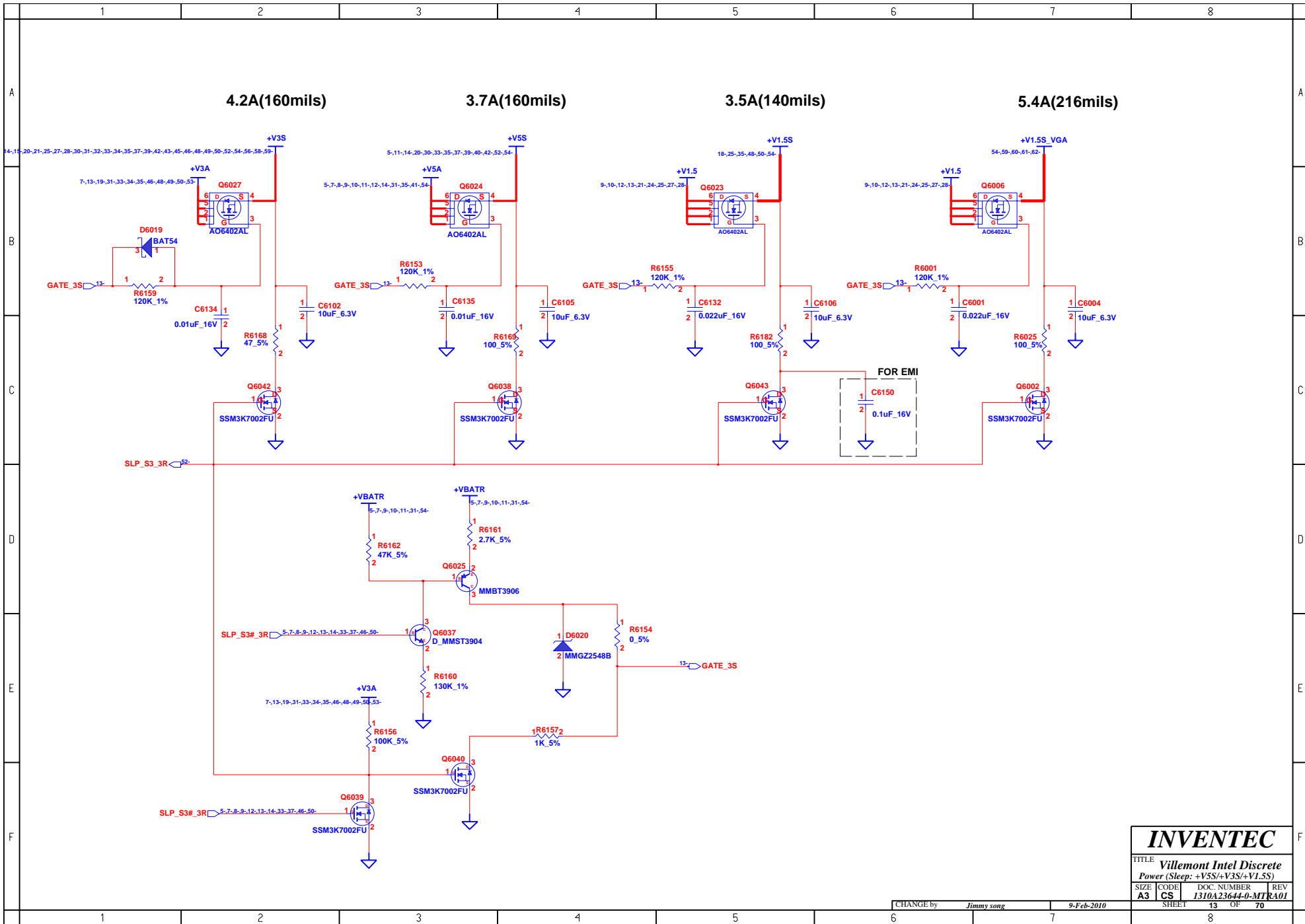

INVENTEC			
TITLE Villemont Intel Discrete			
Power (Sleep: +V5S/+V3S/+V1.5S)			
SIZE	CODE	DOC. NUMBER	REV
A3	CS	1310A23644-0-MT	RA01
CHANGE by <i>Jimmy song</i>		9-Feb-2010	SHEET 13 OF 70

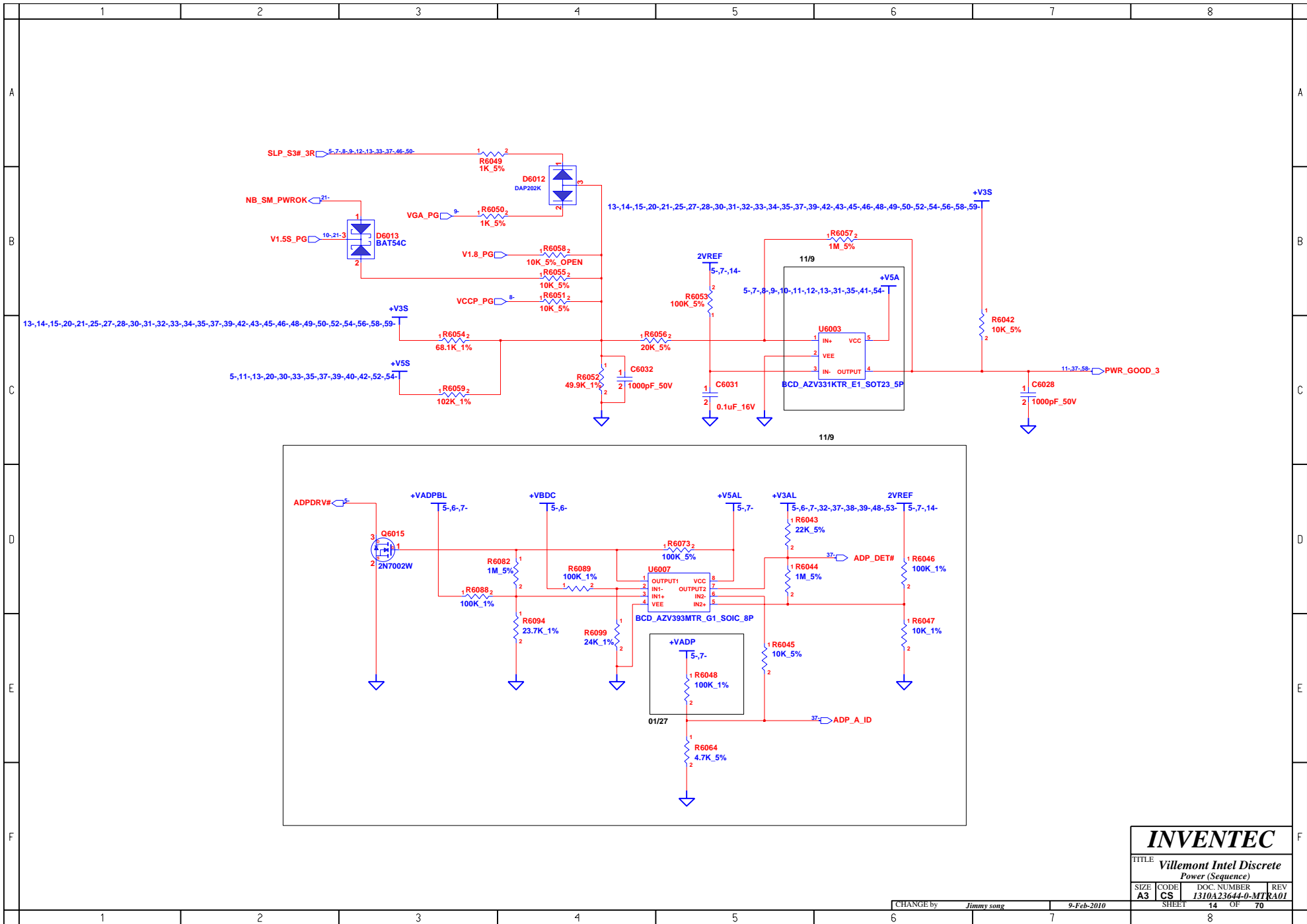

INVENTEC			
TITLE <i>Villemont Intel Discrete Power (Sequence)</i>			
SIZE A3	CODE CS	DOC. NUMBER 1310A23644-0-MTR	REV A01
CHANGE by <i>Jimmy song</i>		9-Feb-2010	
SHEET 14		OF 70	

<http://sualaptop365.edu.vn/mafix.vn>

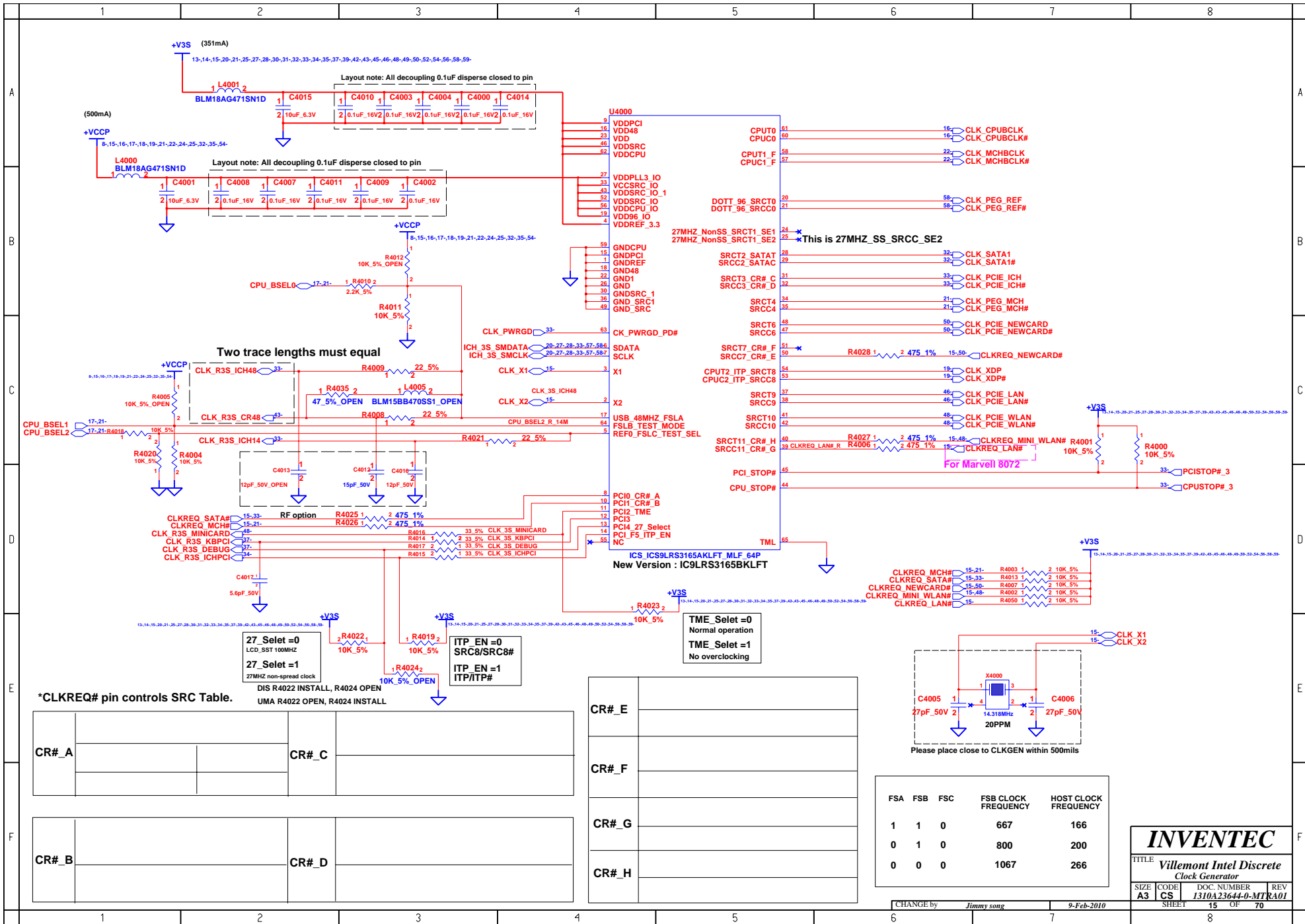

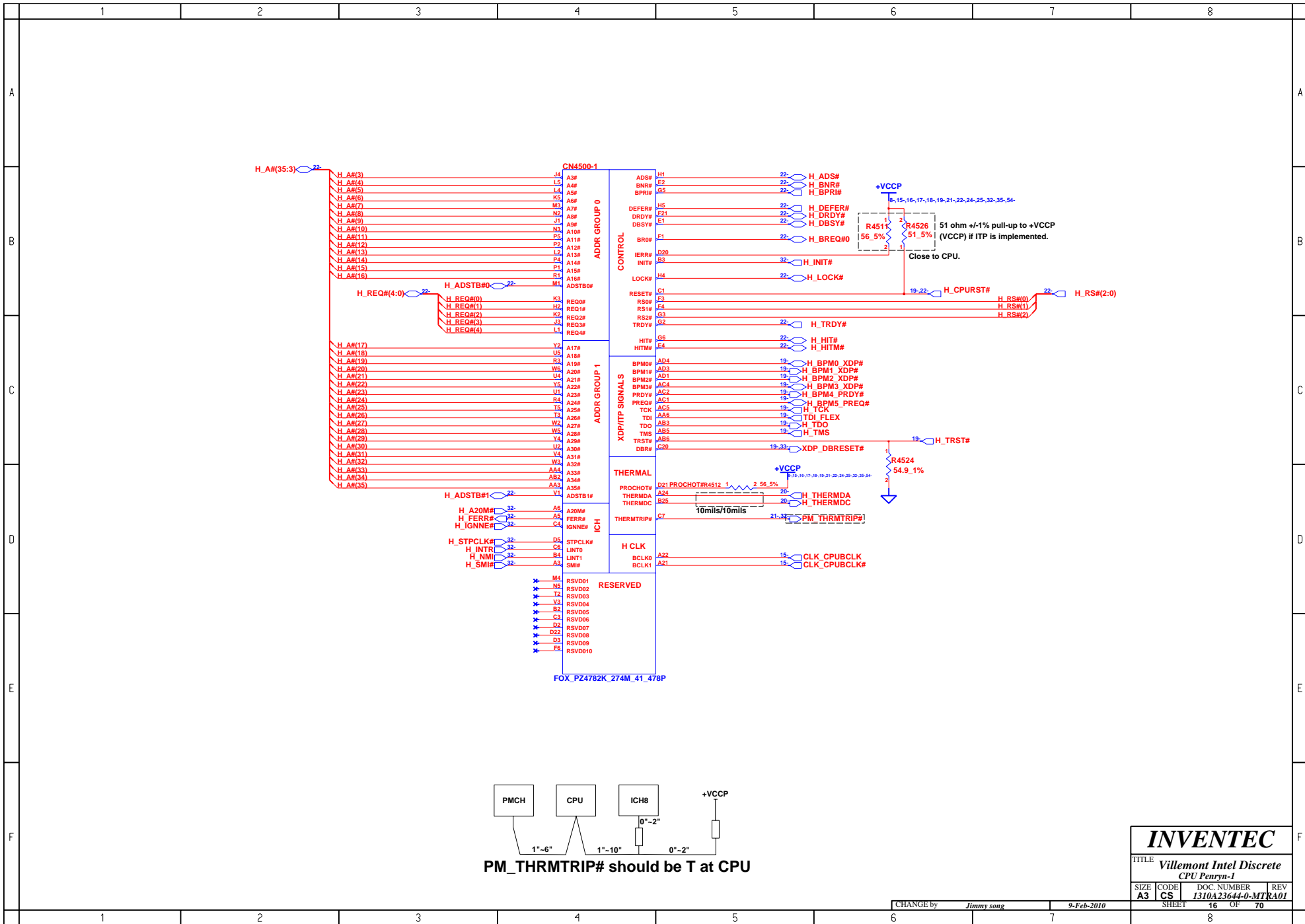

INVENTEC			
TITLE: Villemont Intel Discrete CPU Penryn-1			
SIZE: A3	CODE: CS	DOC NUMBER: 1310A23644-0-MT	REV: RA01
CHANGE by: <i>Jimmy song</i>		9-Feb-2010	
SHEET: 16		OF: 70	

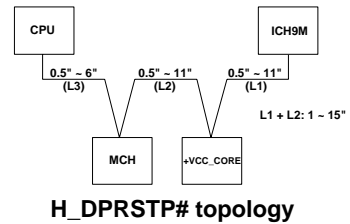
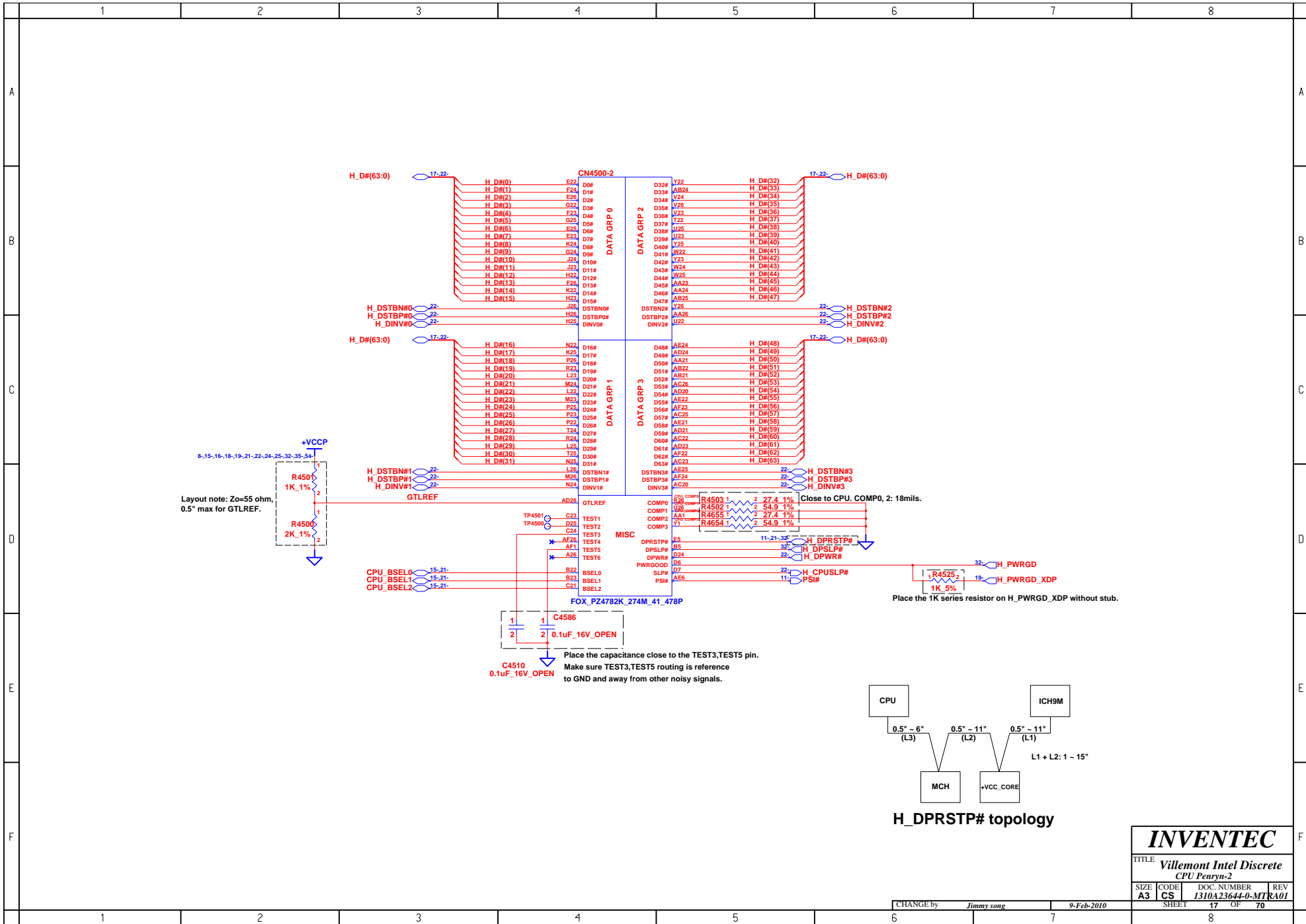

INVENTEC			
TITLE Villemont Intel Discrete CPU Penryn-2			
SIZE A3	CODE CS	DOC NUMBER I310A23644-0-MTR	REV RA01
CHANGE by <i>Jimmy song</i>		9-Feb-2010	
SHEET 17		OF 70	

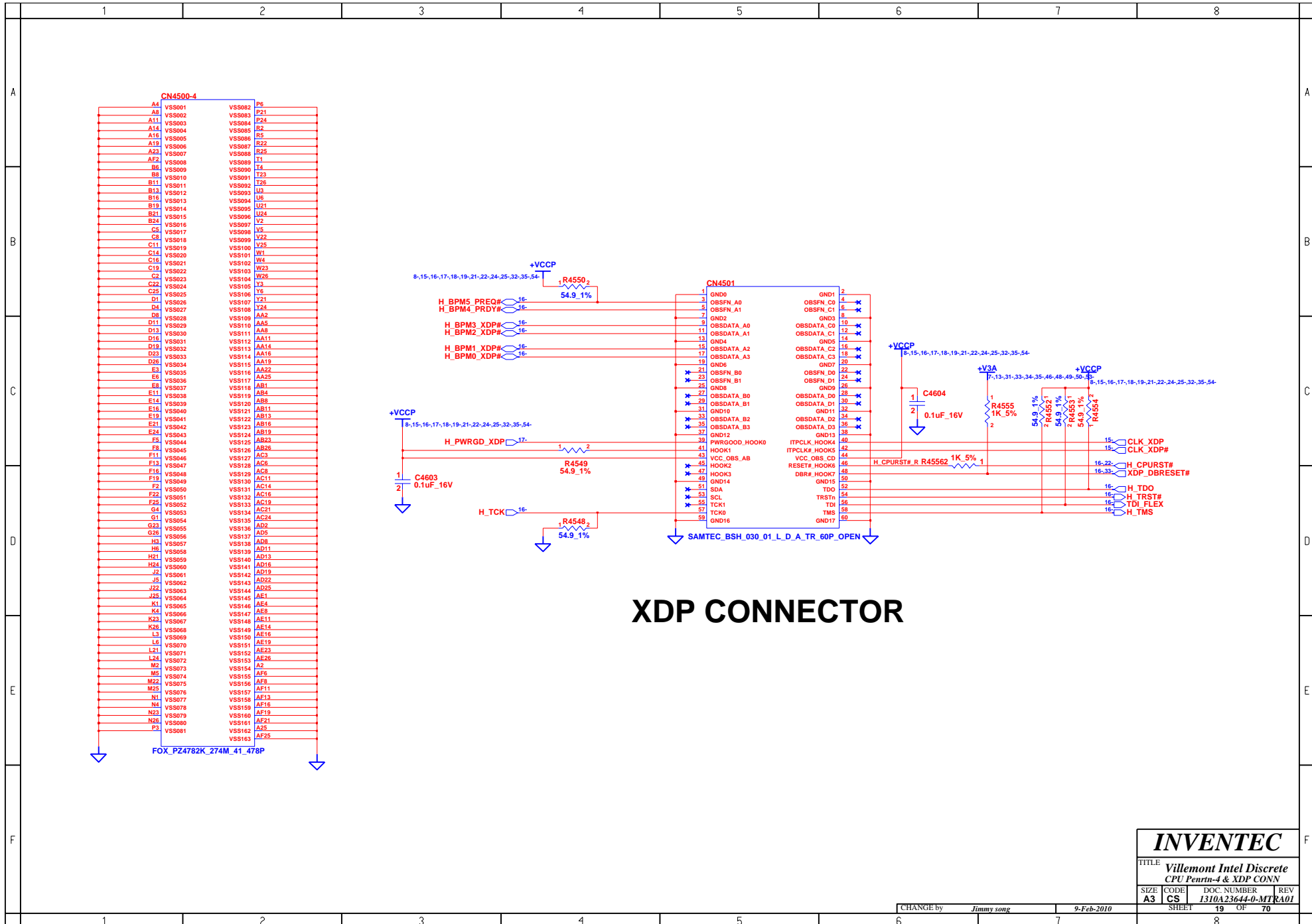

XDP CONNECTOR

INVENTEC			
TITLE: Villemont Intel Discrete CPU Penryn-4 & XDP CONN			
SIZE: A3	CODE: CS	DOC. NUMBER: 1310A23644-0-MTR	REV: RA01
CHANGE by: <i>Jimmy song</i>		9-Feb-2010	
SHEET: 19		OF: 70	

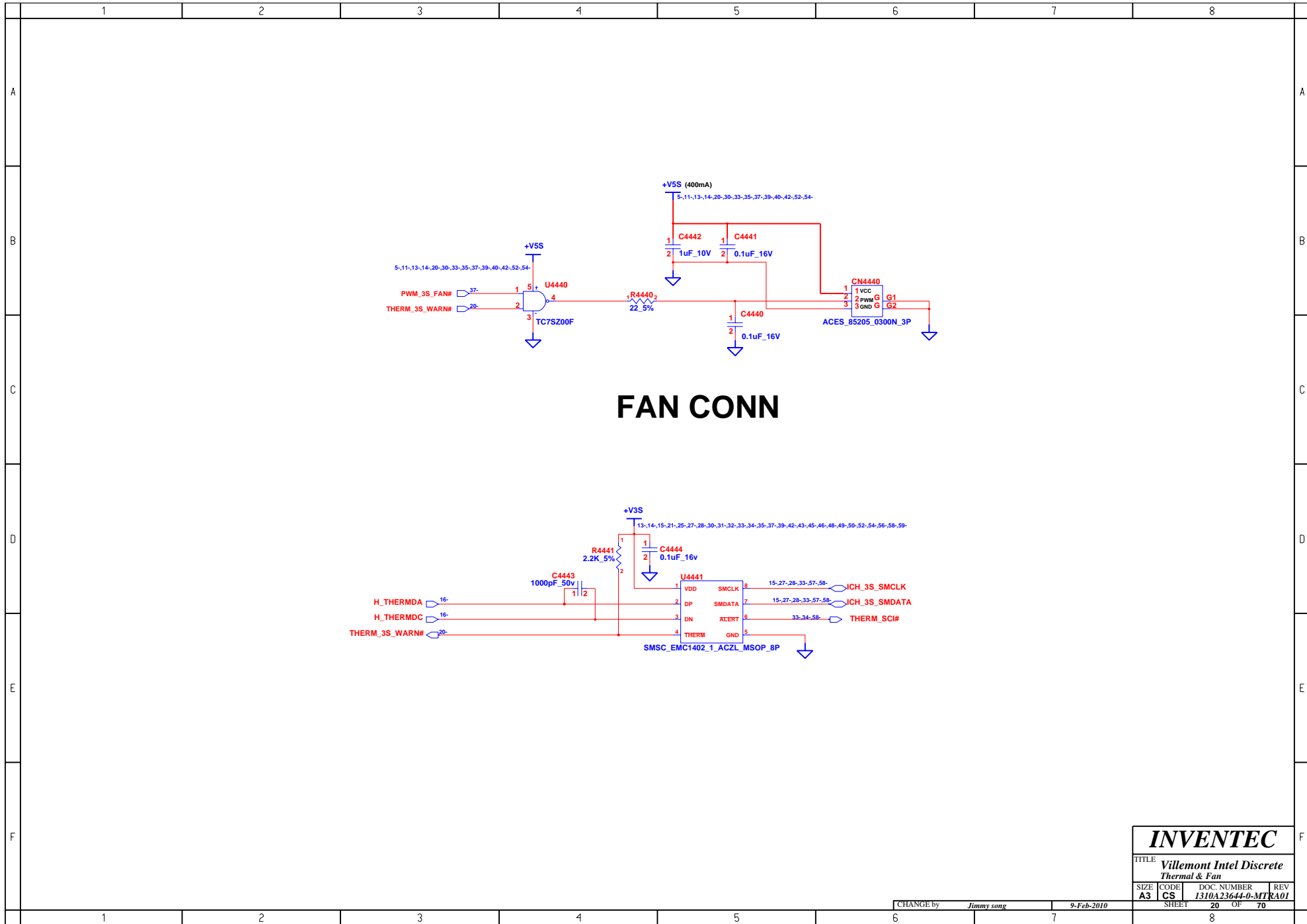

INVENTEC			
TITLE <i>Villemont Intel Discrete Thermal & Fan</i>			
SIZE A3	CODE CS	DOC. NUMBER 1310A23644-0-MT	REV KA01
CHANGE by <i>Jimmy song</i>		9-Feb-2010	
SHEET 20		OF 70	

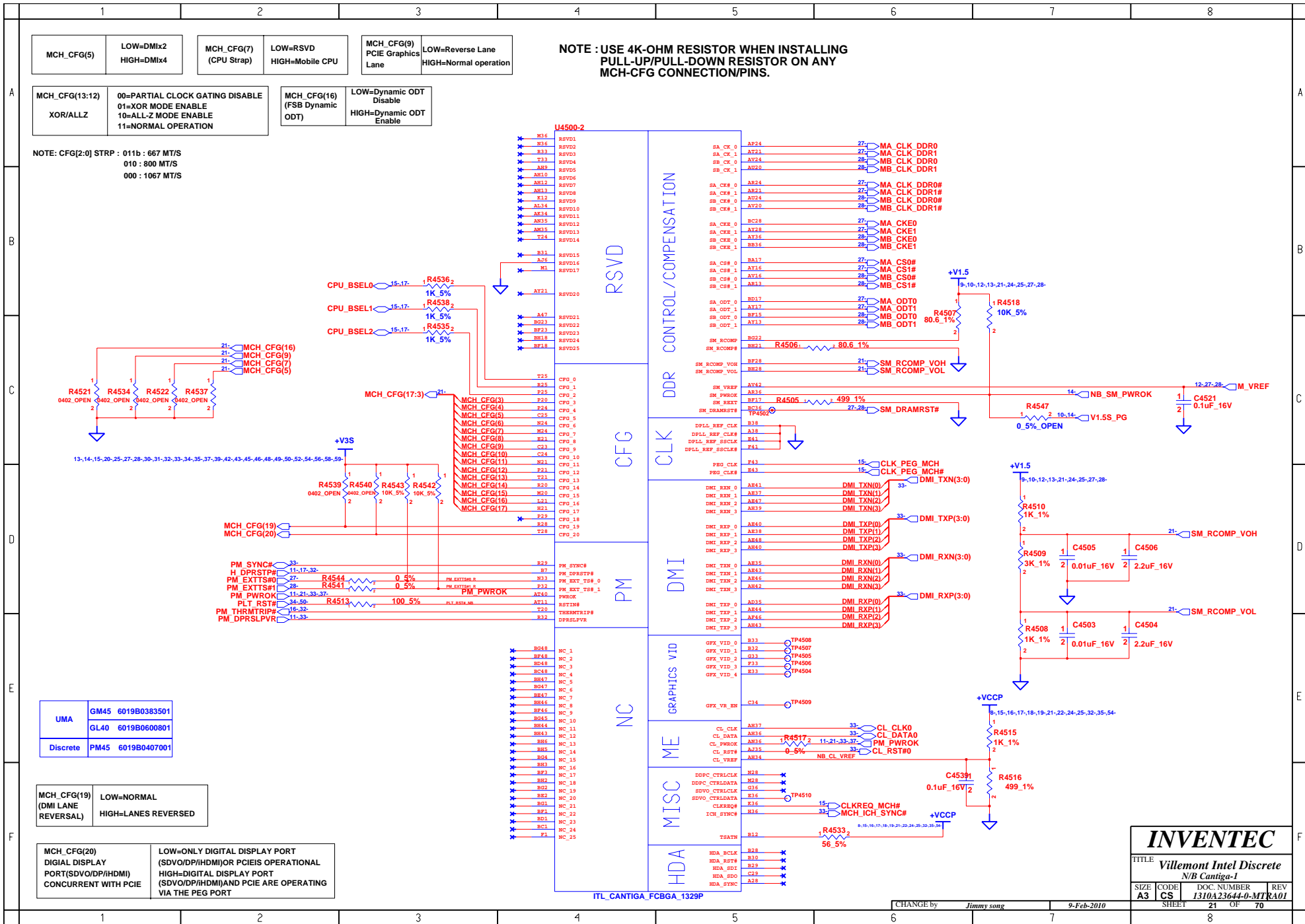

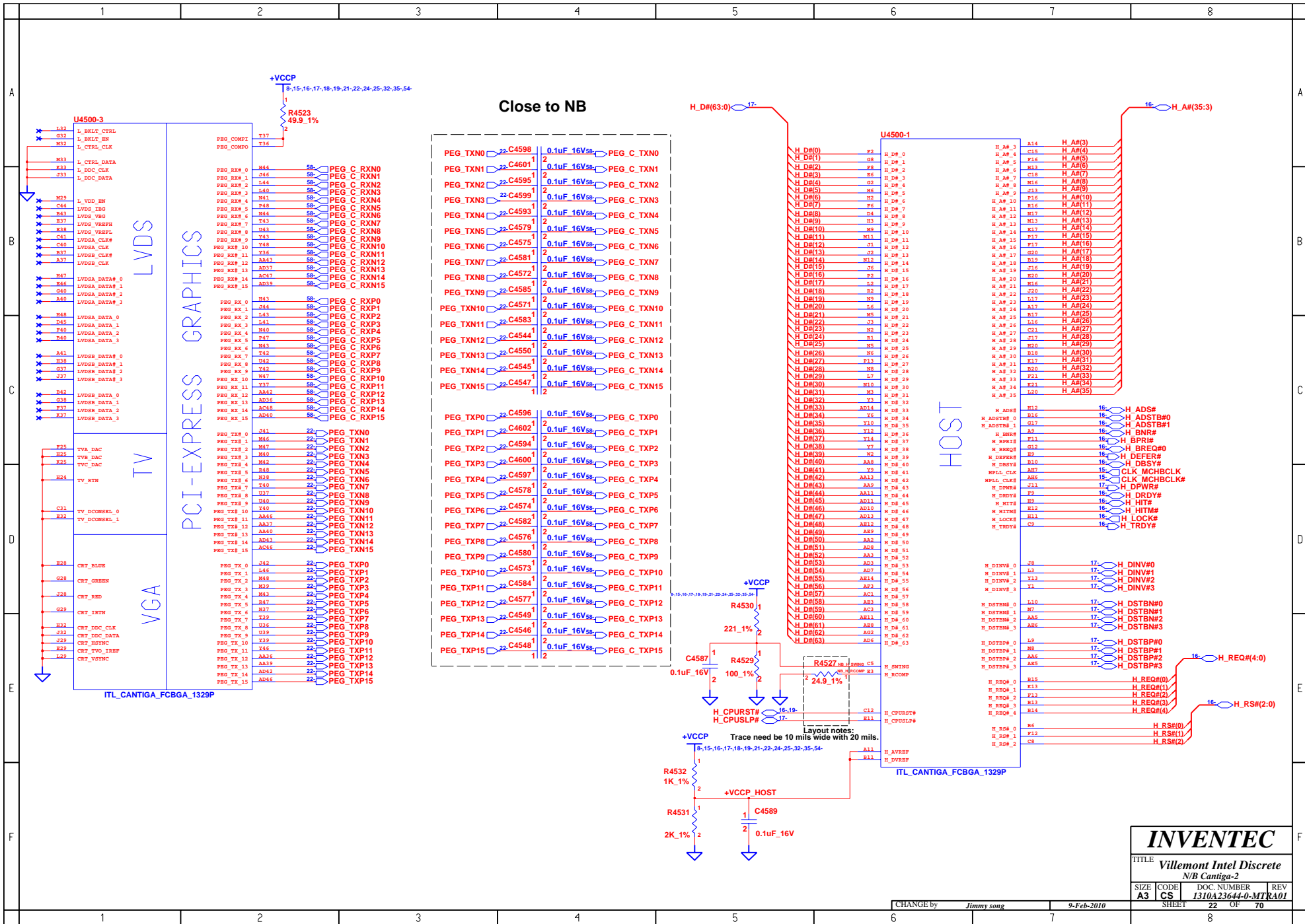

INVENTEC

TITLE: **Villemont Intel Discrete**
N/B Cantiga-2

SIZE	CODE	DOC. NUMBER	REV
A3	CS	1310A23644-0-MT	KA01

SHEET 22 OF 70

CHANGE by Jimmy song 9-Feb-2010

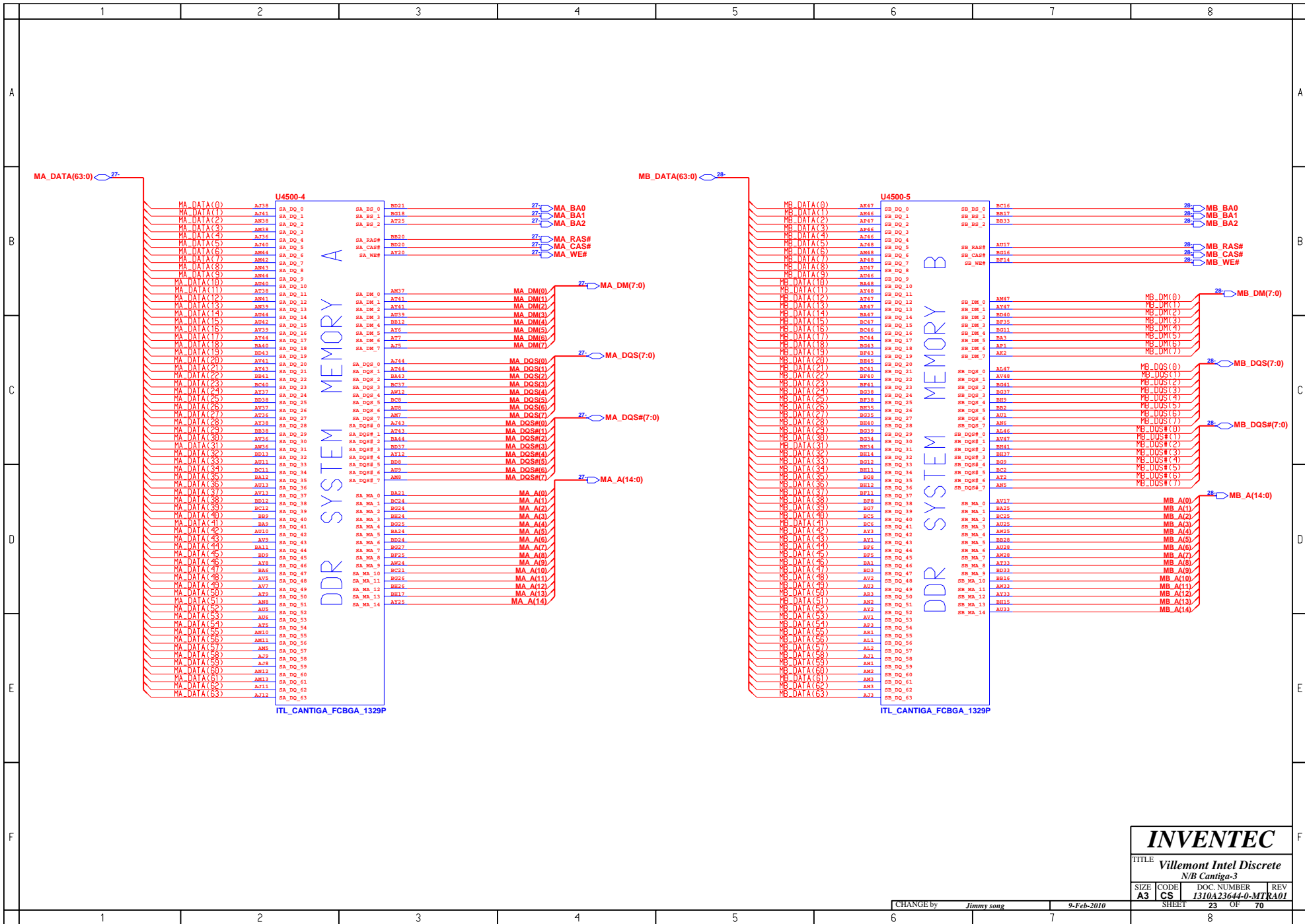

INVENTEC			
TITLE Villemont Intel Discrete			
N/B Cantiga-3			
SIZE	CODE	DOC. NUMBER	REV
A3	CS	1310A23644-0-MTR	RA01
CHANGE by <i>Jimmy song</i>		9-Feb-2010	
SHEET 23		OF 70	

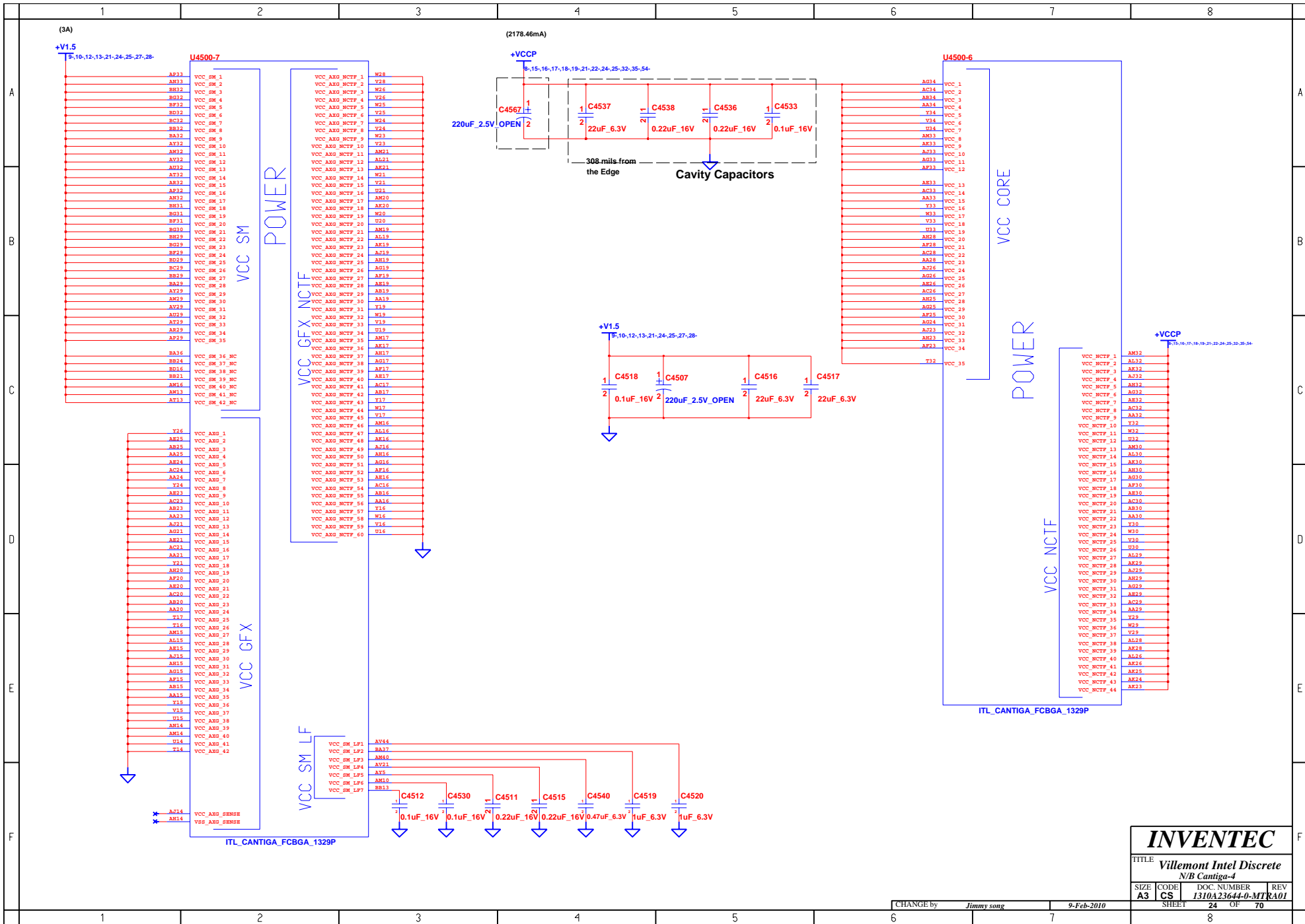

INVENTEC			
TITLE Villemont Intel Discrete N/B Cantiga-4			
SIZE A3	CODE CS	DOC NUMBER I310A23644-0-MT	REV RA01
CHANGE by Jimmy song		9-Feb-2010	
SHEET 24		OF 70	

http://sualaptop365.com/mafiafix.vn

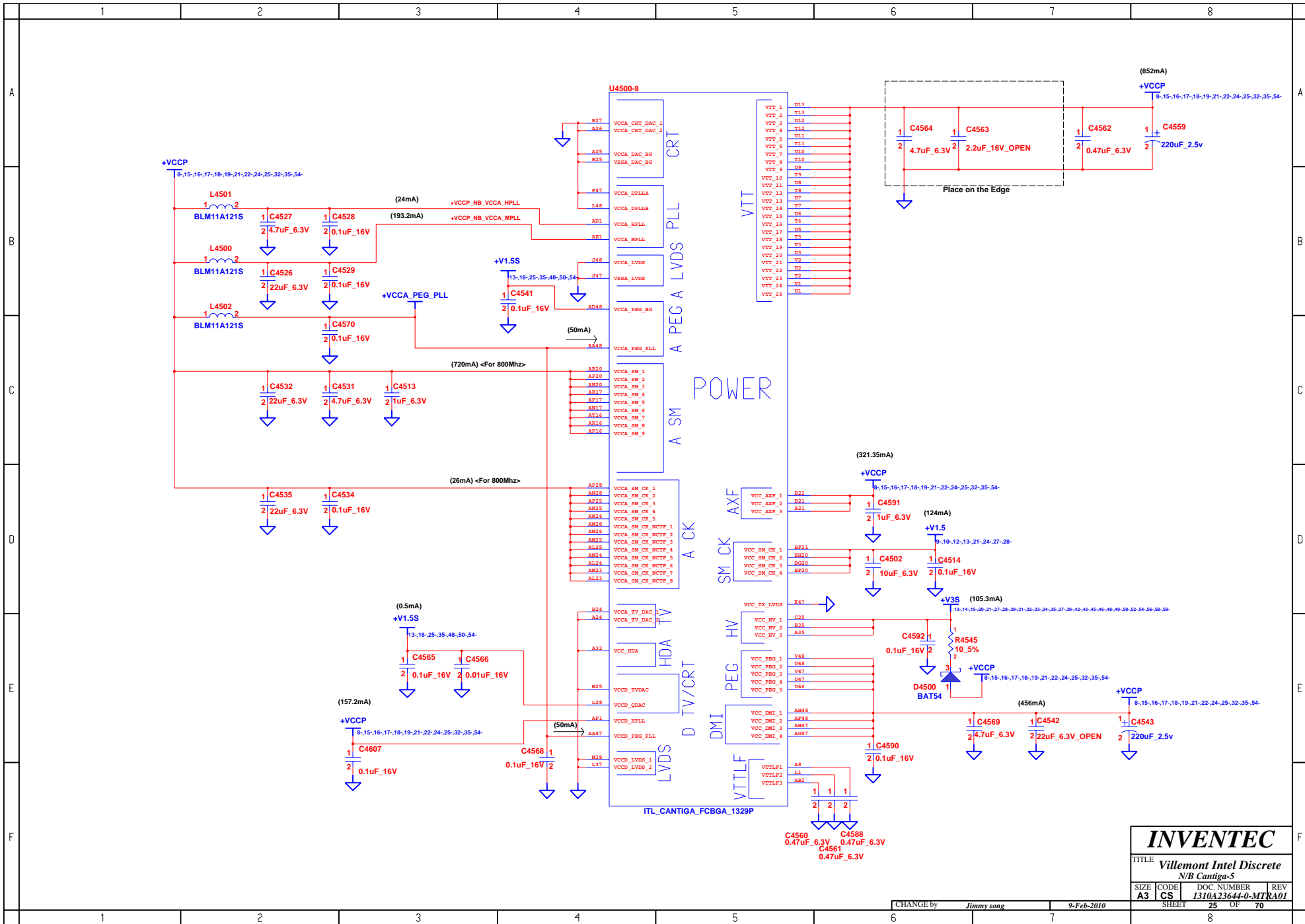

INVENTEC				
TITLE Villemont Intel Discrete N/B Cantiga-S				
SIZE A3	CODE CS	DOC NUMBER I310A23644-0-MT	REV R01	
CHANGE by Jimmy song		9-Feb-2010		
SHEET 25			OF 70	

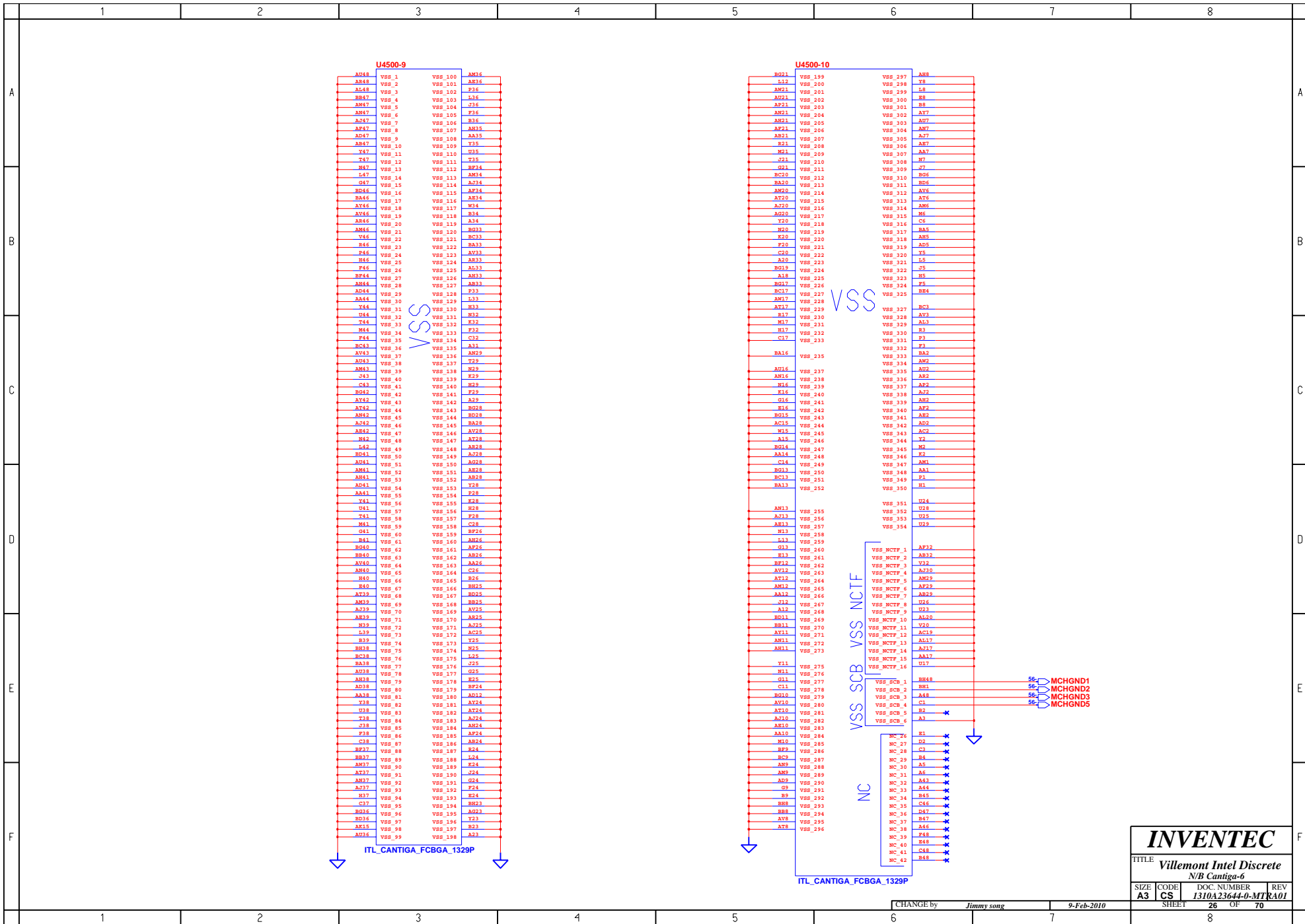

<http://sualap.com> www.vimafix.vn

INVENTEC			
TITLE Villemont Intel Discrete			
N/B Cantiga-6			
SIZE	CODE	DOC. NUMBER	REV
A3	CS	1310A23644-0-MT	RA01
SHEET		OF	
26		70	

CHANGE by Jimmy song 9-Feb-2010

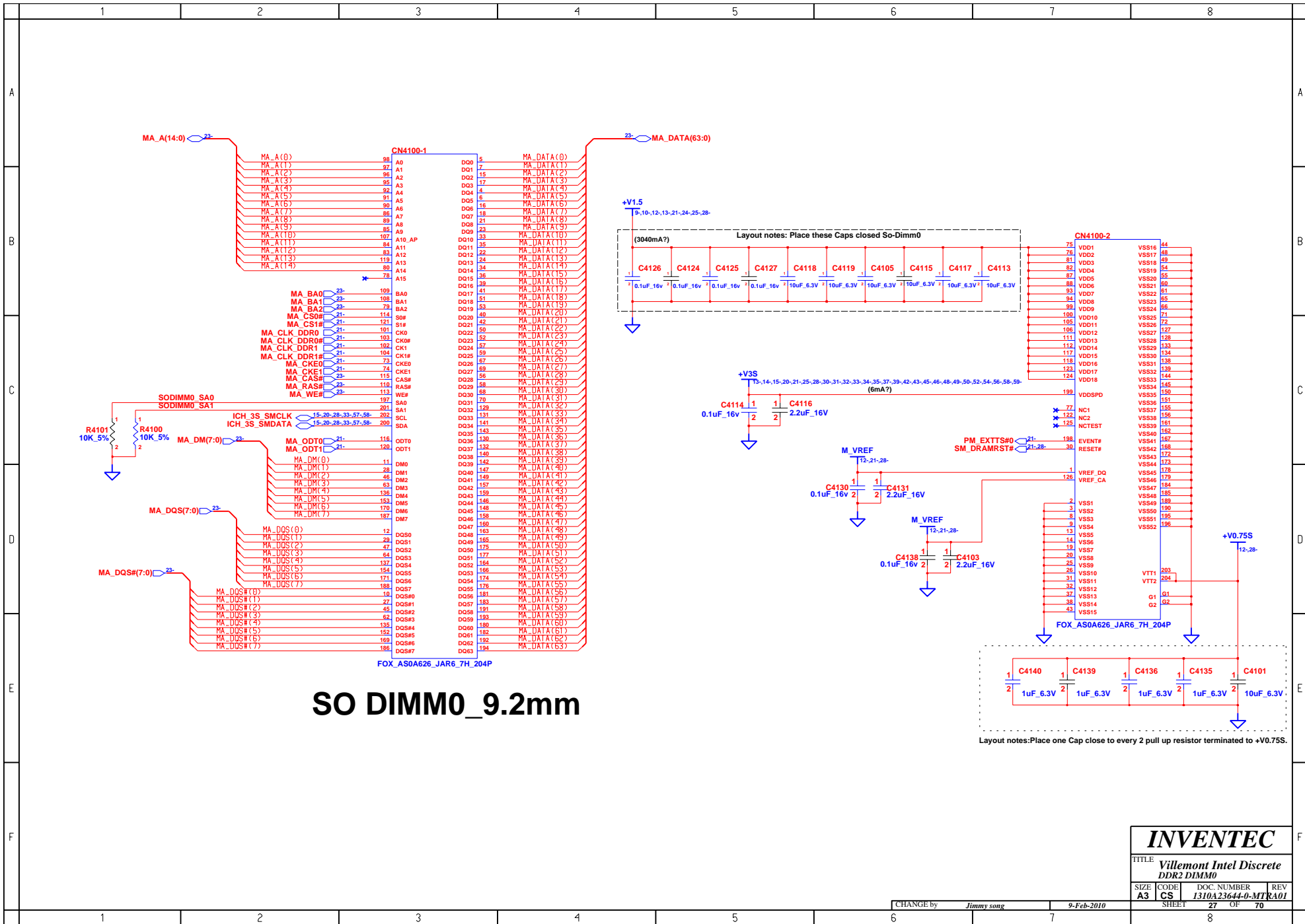

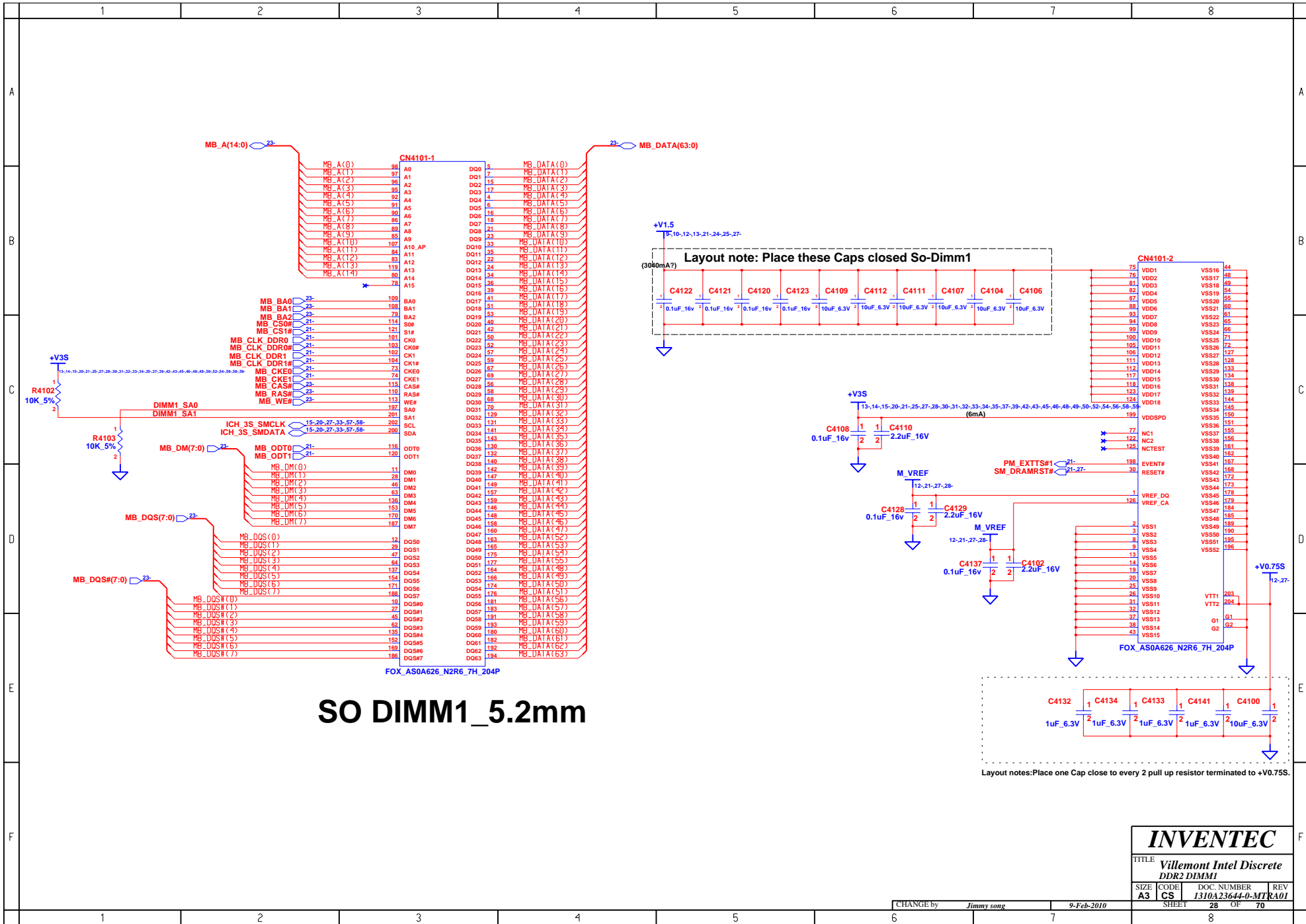

<http://sualaptop365.com>
www.vietnamfix.vn

BLANK

INVENTEC			
TITLE Villemont Intel Discrete			
DDR2 Damping			
SIZE	CODE	DOC. NUMBER	REV
A3	CS	1310A23644-0-MTR	A01
CHANGE by <i>Jimmy song</i>		27-Sep-2003	
SHEET		29	OF 70

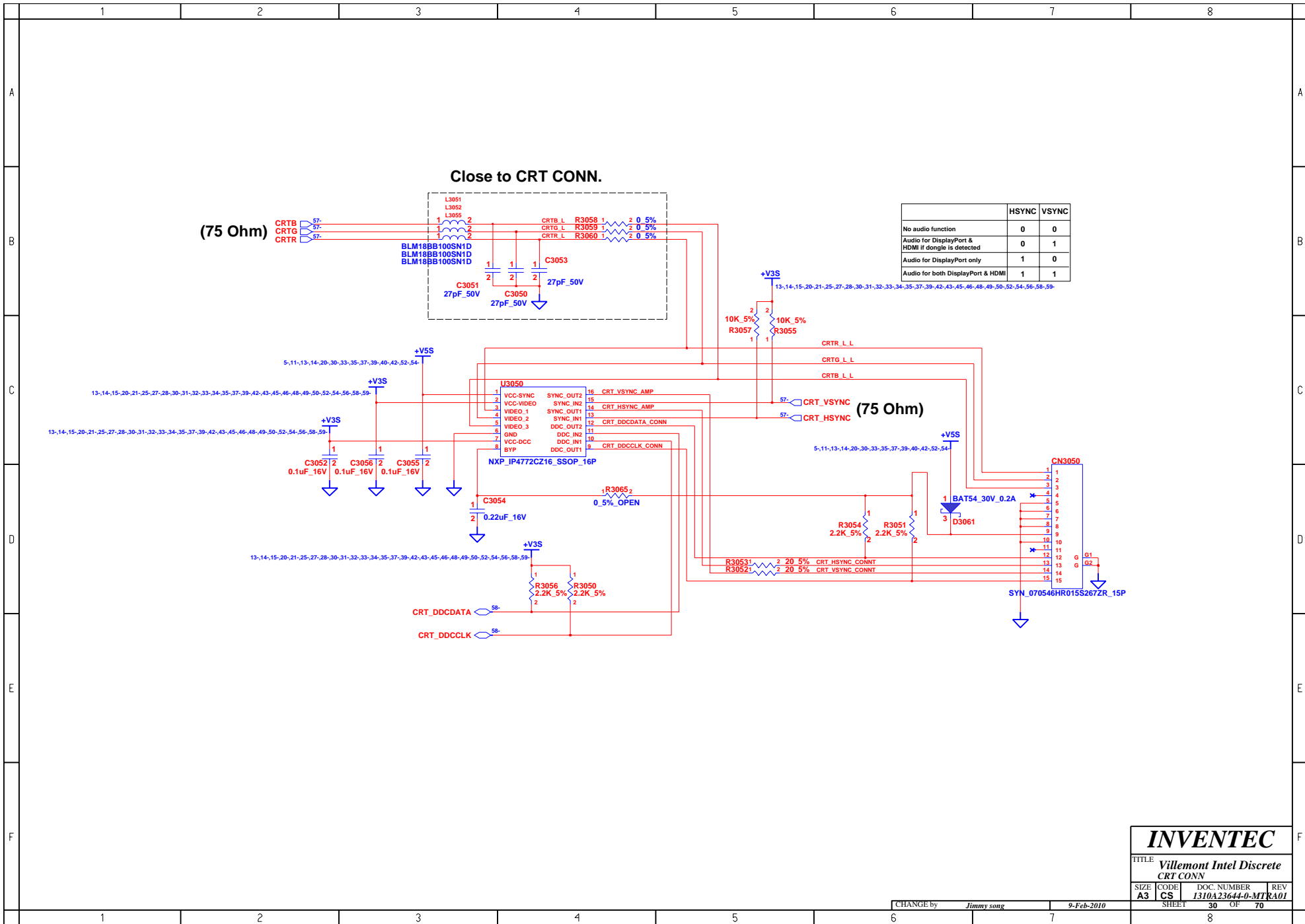

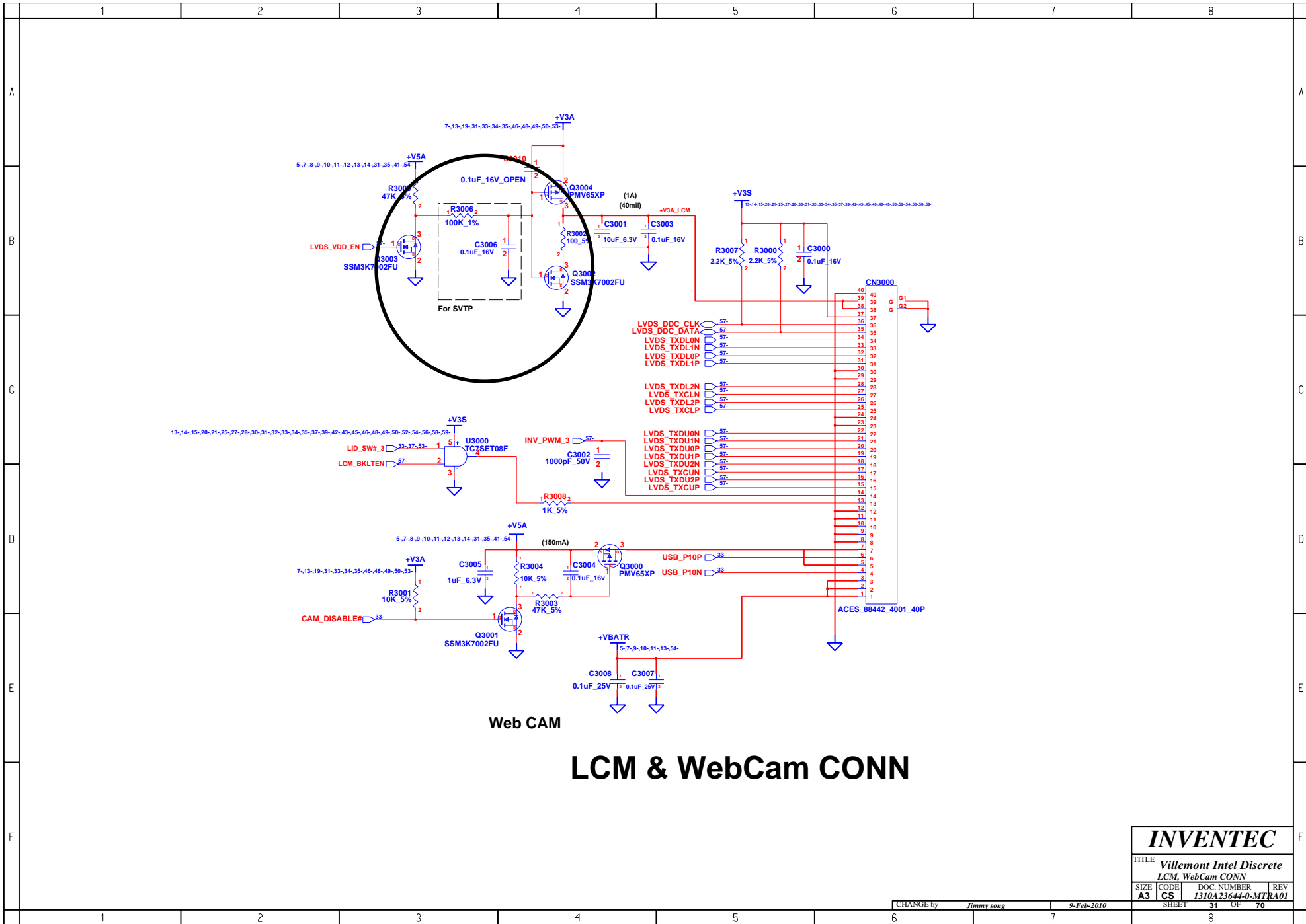

LCM & WebCam CONN

INVENTEC

TITLE			
Villemont Intel Discrete			
LCM, WebCam CONN			
SIZE	CODE	DOC. NUMBER	REV
A3	CS	1310A23644-0-MTR	RA01

CHANGE by	Jimmy song	9-Feb-2010	SHEET	31	OF	70
-----------	------------	------------	-------	----	----	----

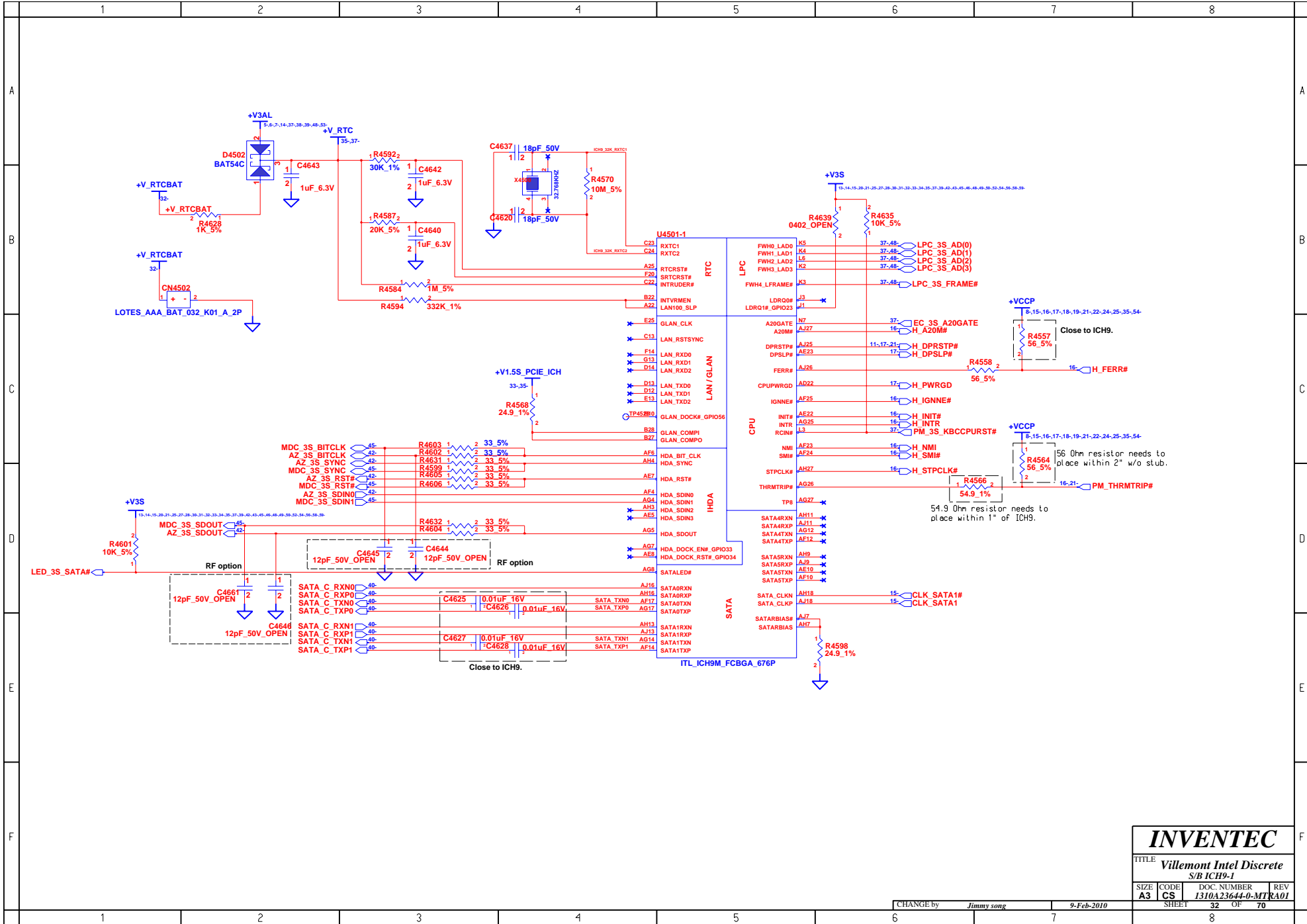

INVENTEC			
TITLE Villemont Intel Discrete S/B ICH9-1			
SIZE	CODE	DOC NUMBER	REV
A3	CS	I310A23644-0-MTR	RA01
CHANGE by <i>Jimmy song</i>		9-Feb-2010	
SHEET 32		OF 70	

http://sualaptop365.com.vn/mafix.vn

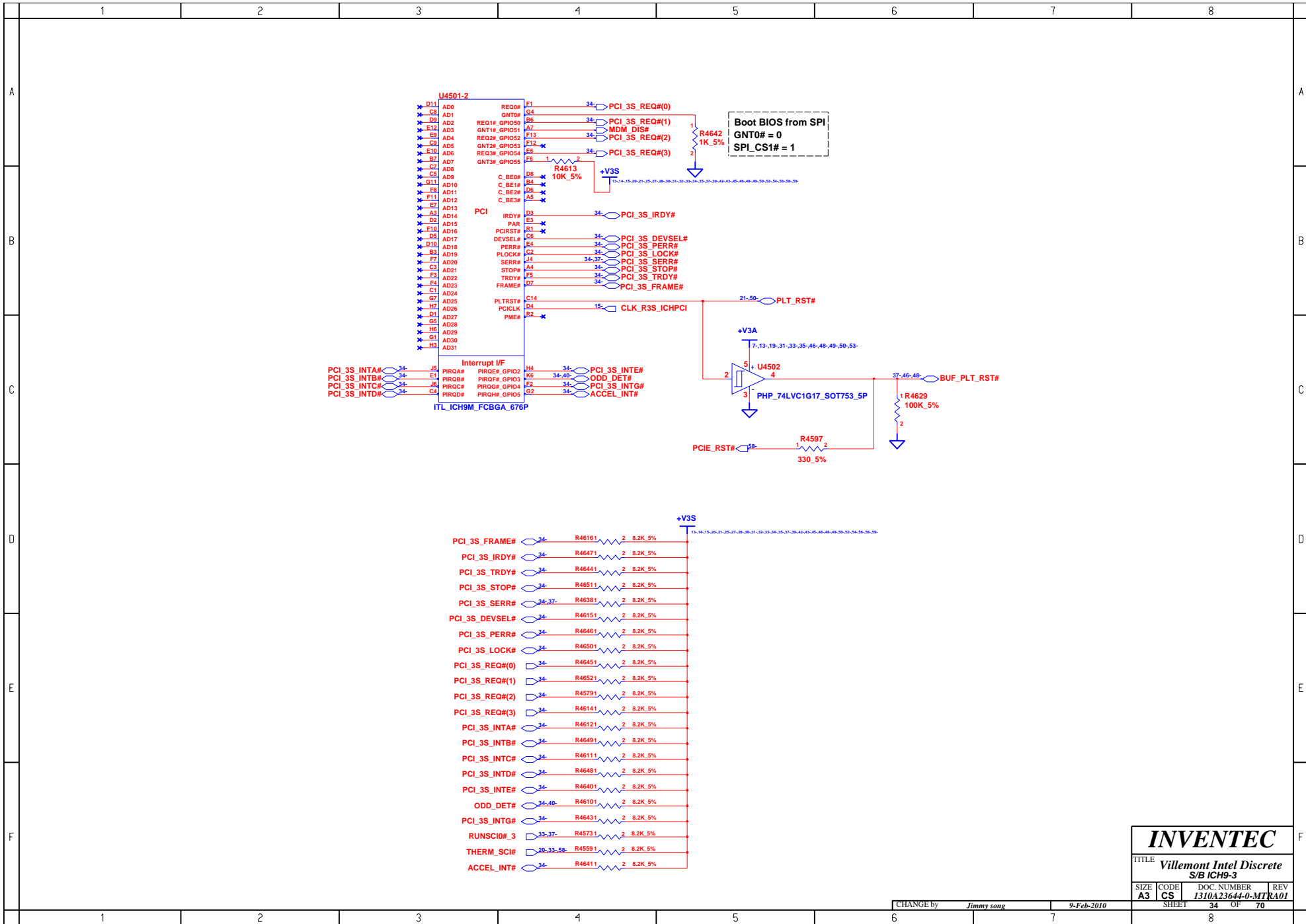

INVENTEC			
TITLE Villemont Intel Discrete S/B ICH9-3			
SIZE A3	CODE CS	DOC. NUMBER I310A23644-0-MTR	REV RA01
CHANGE by <i>Jimmy song</i>		9-Feb-2010	
SHEET 34		OF 70	

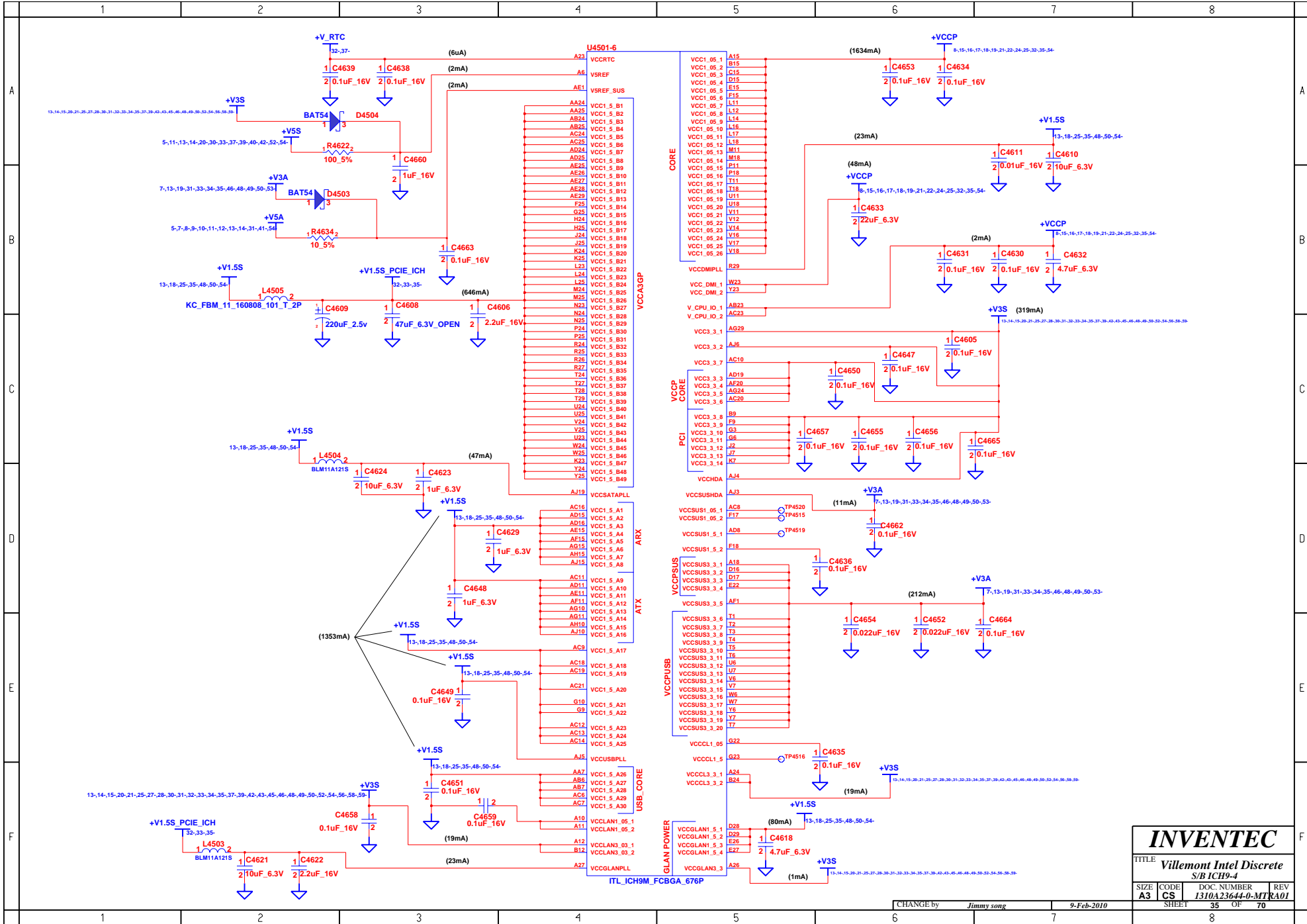

INVENTEC

TITLE: **Villemont Intel Discrete S/B ICH9-4**

SIZE	CODE	DOC. NUMBER	REV
A3	CS	I310A23644-0-MTR	KA01

SHEET 35 OF 70

CHANGE by *Jimmy song* 9-Feb-2010

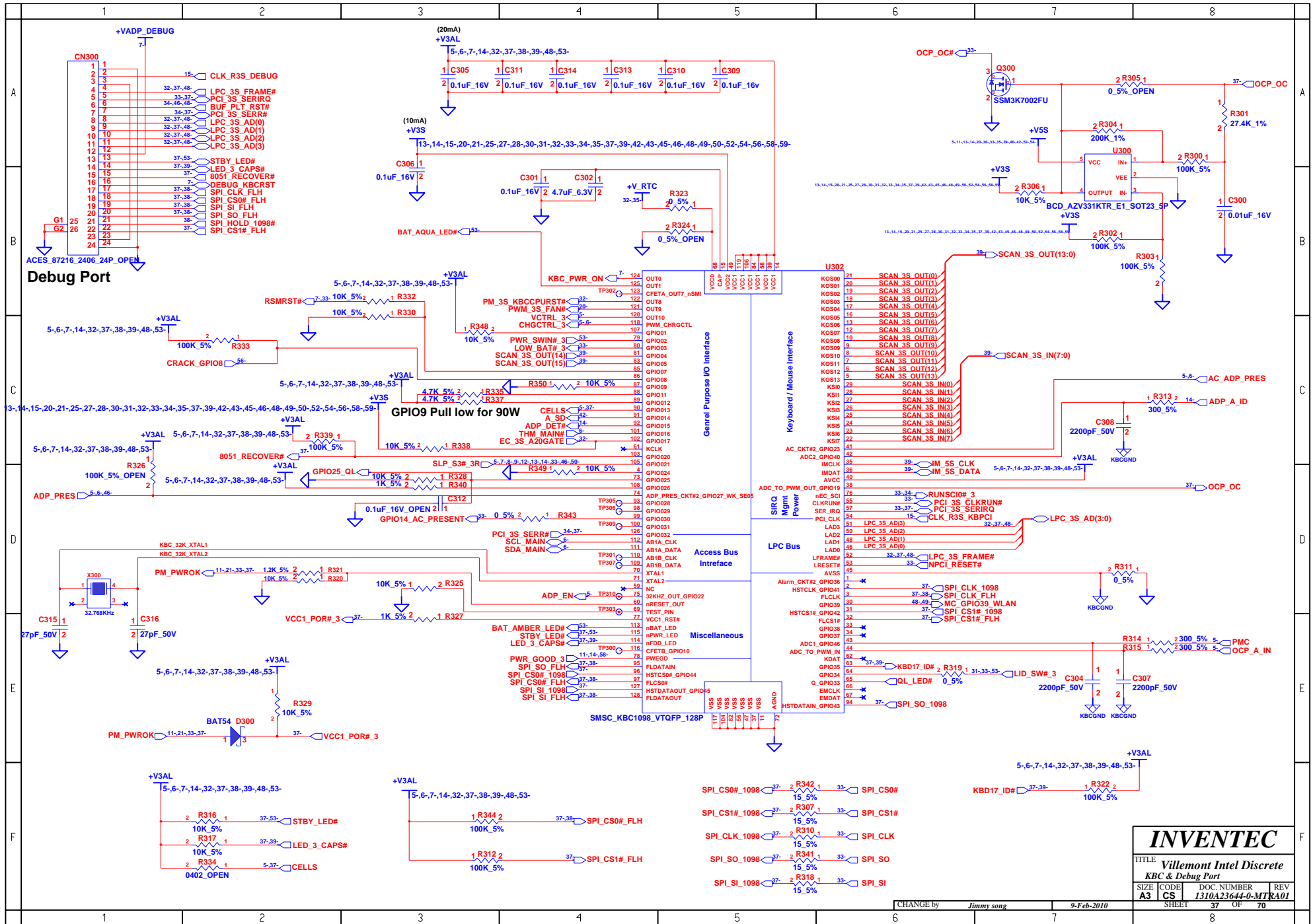

INVENTEC

TITLE **Villemont Intel Discrete**
KBC & Debug Port

SIZE	CODE	DOC. NUMBER	REV
A3	CS	1310A23644-0-MTR	RA01

SHEET 37 OF 70

CHANGE by *Junmy song* 9-Feb-2010

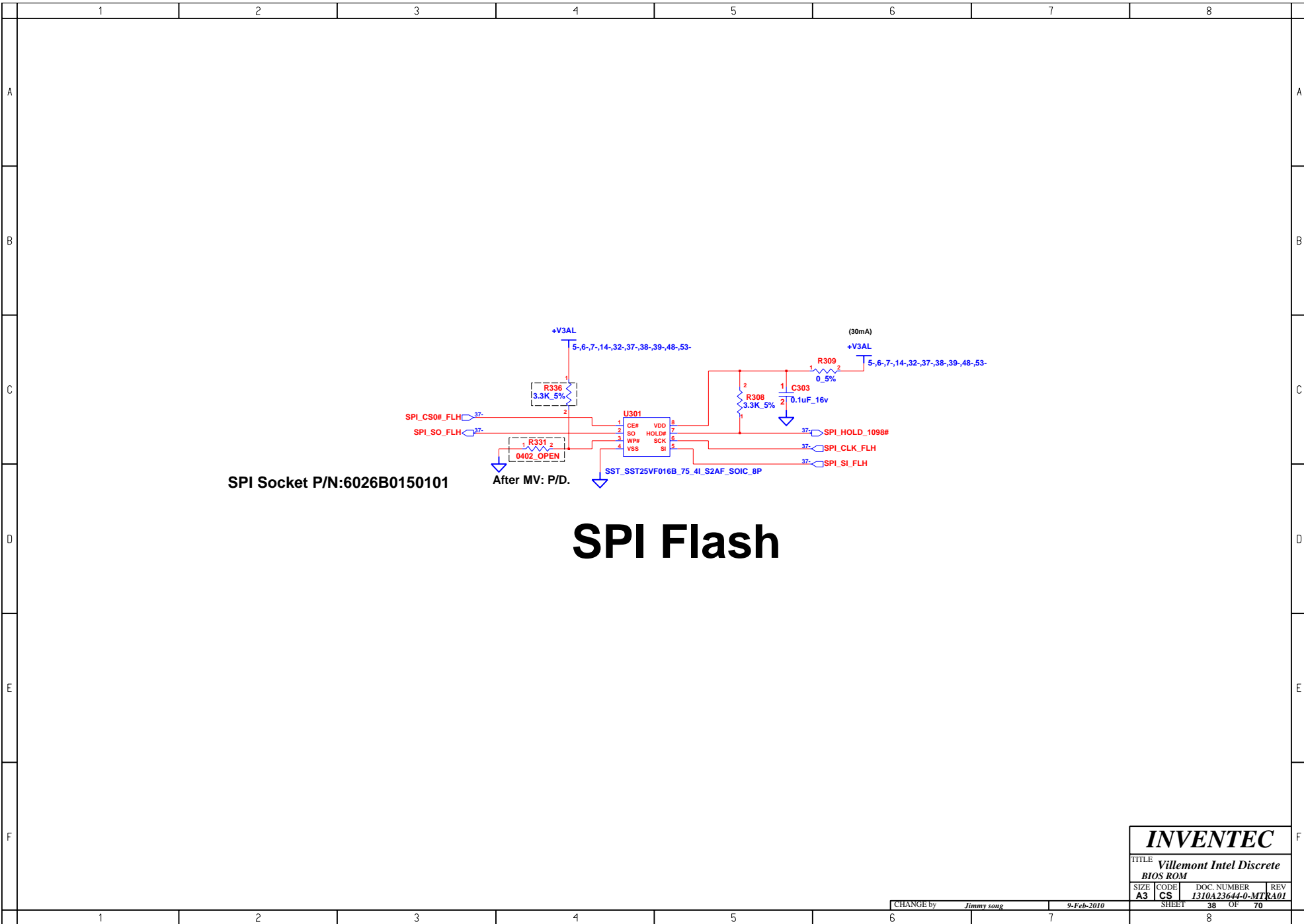

INVENTEC			
TITLE <i>Villemont Intel Discrete</i>			
BIOS ROM			
SIZE	CODE	DOC. NUMBER	REV
A3	CS	1310A23644-0-MT	KA01
CHANGE by <i>Jimmy song</i>		9-Feb-2010	SHEET 38 OF 70

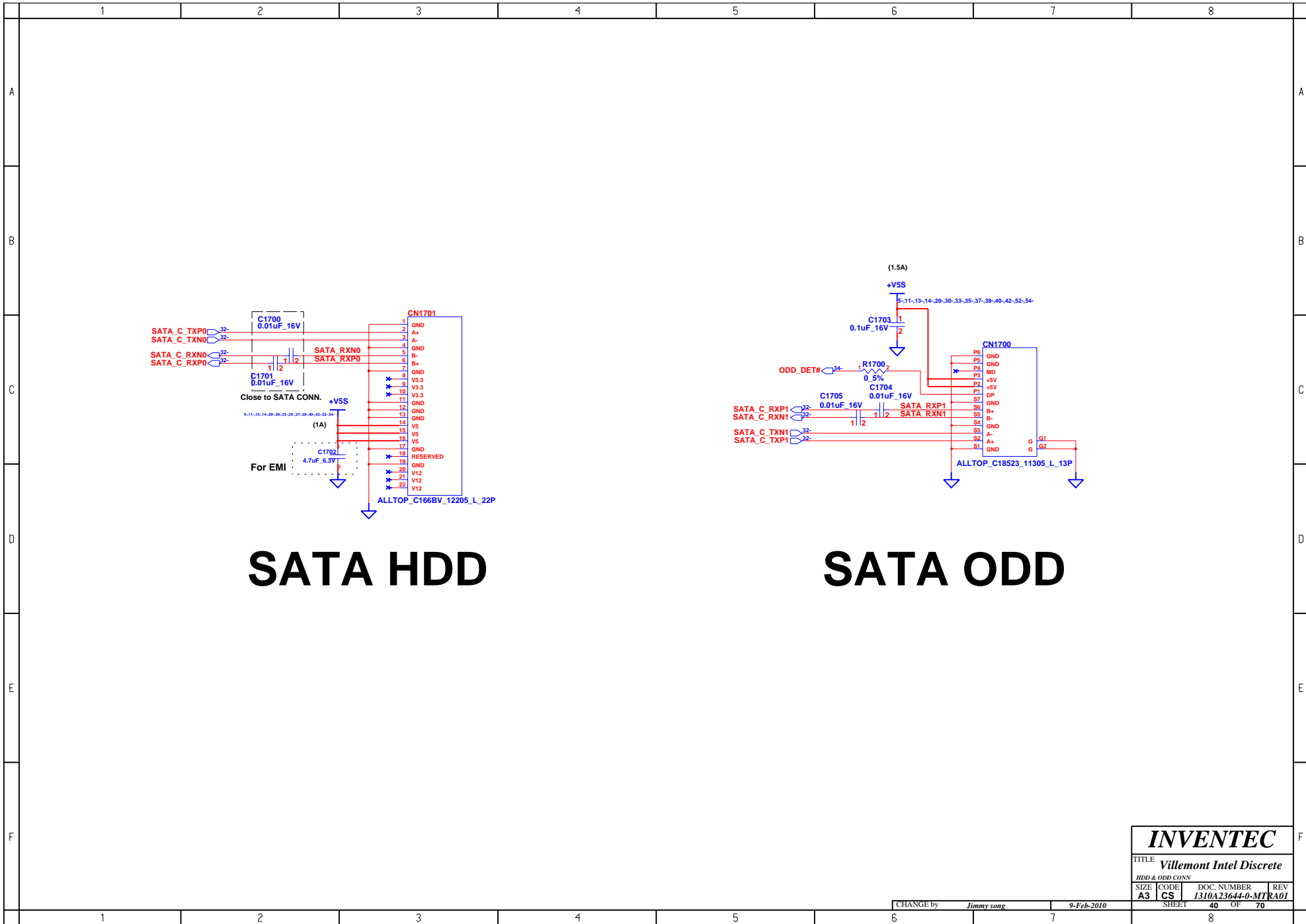

INVENTEC			
TITLE Villemont Intel Discrete			
HDD & ODD CONN			
SIZE A3	CODE CS	DOC. NUMBER 1310A23644-0-MT	REV RA01
CHANGE by <i>Jimmy song</i>		9-Feb-2010	
SHEET 40		OF 70	

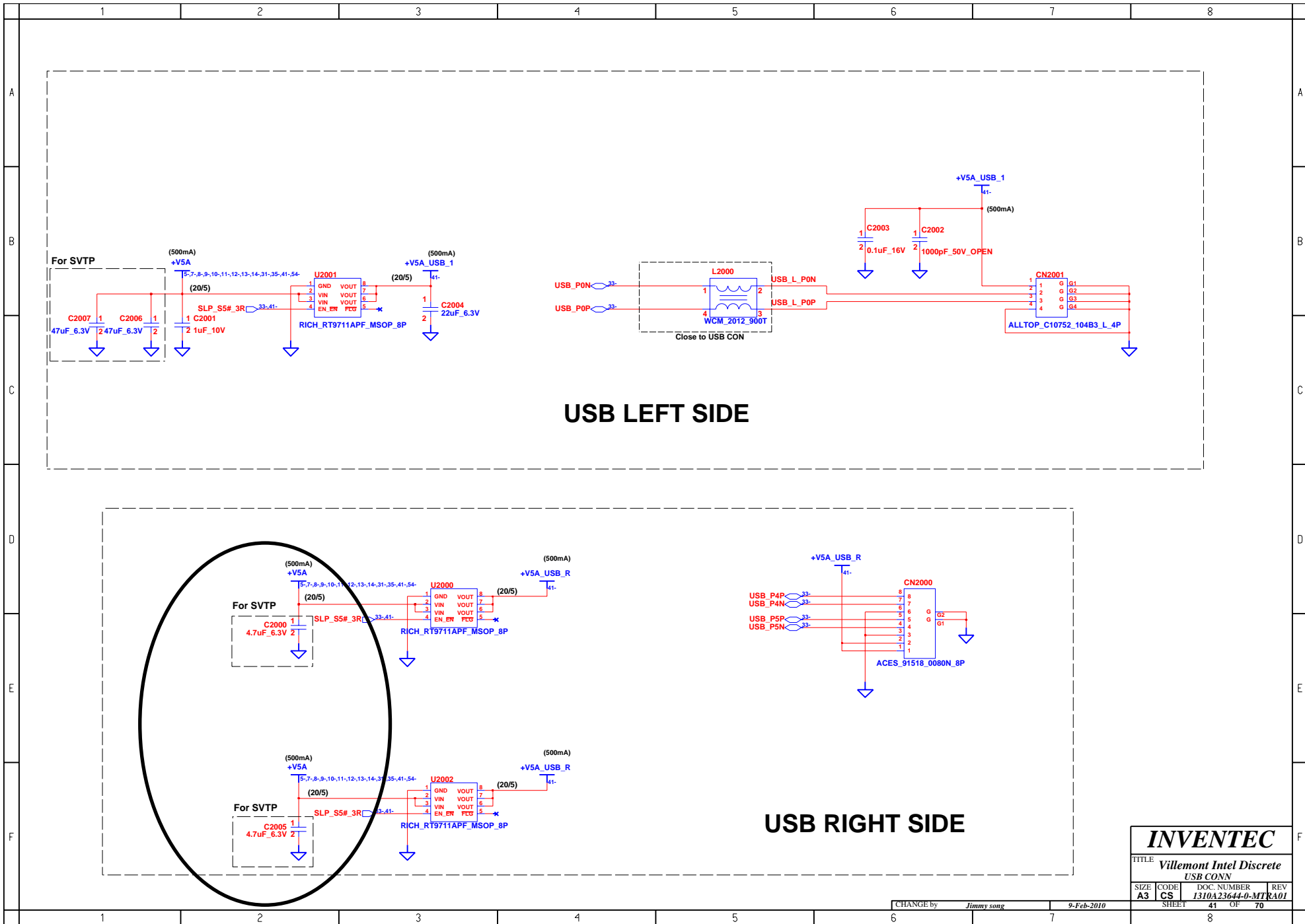

SD/MMC & AUDIO JACK CONNECTOR MB SIDE

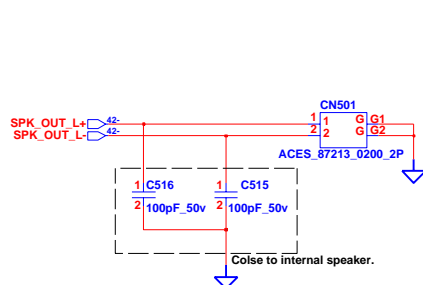
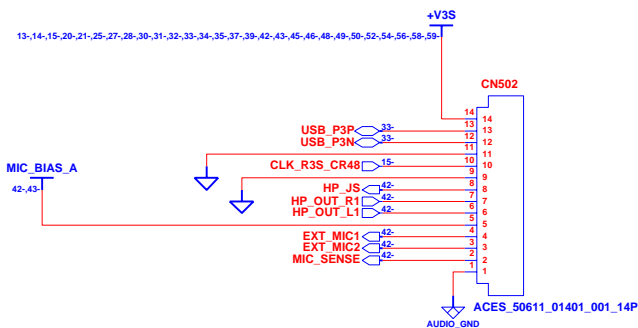
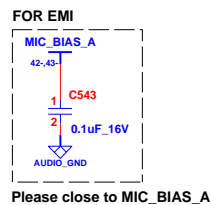

Internal Speaker

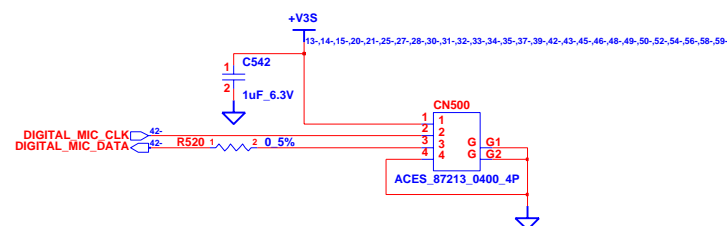

INT. DIGITAL MIC

INVENTEC

TITLE
**Villemont Intel Discrete
Earphone & MIC JACK Board**

SIZE A3	CODE CS	DOC NUMBER 1310A23644-0-MT	REV RA01
-------------------	-------------------	--------------------------------------	--------------------

CHANGE by *Jimmy song* 9-Feb-2010

SHEET 43 OF 70

BLANK

INVENTEC			
TITLE <i>Villemont Intel Discrete AUDIO AMP & HP JACK</i>			
SIZE A3	CODE CS	DOC. NUMBER <i>1310A23644-0-MTR</i>	REV A01
CHANGE by <i>Jimmy song</i>		9-Feb-2010	
SHEET		44	OF 70

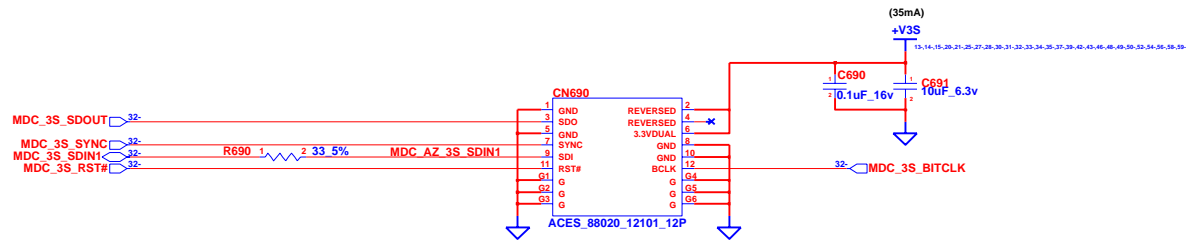

MDC CONN

INVENTEC			
TITLE <i>Villemont Intel Discrete</i>			
MDC CONN			
SIZE	CODE	DOC. NUMBER	REV
A3	CS	1310A23644-0-MTR	A01
CHANGE by <i>Jimmy song</i>		9-Feb-2010	SHEET 45 OF 70

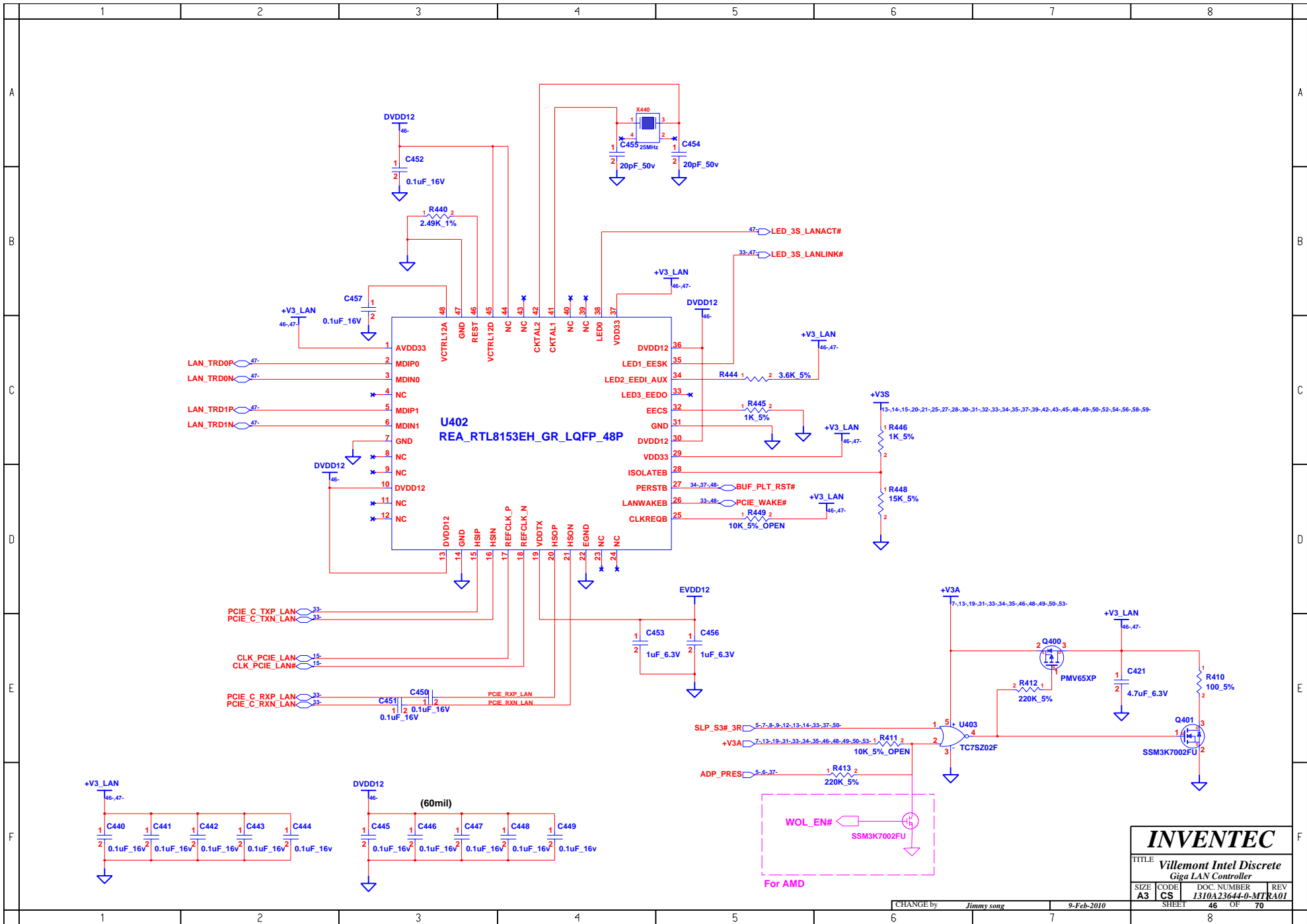

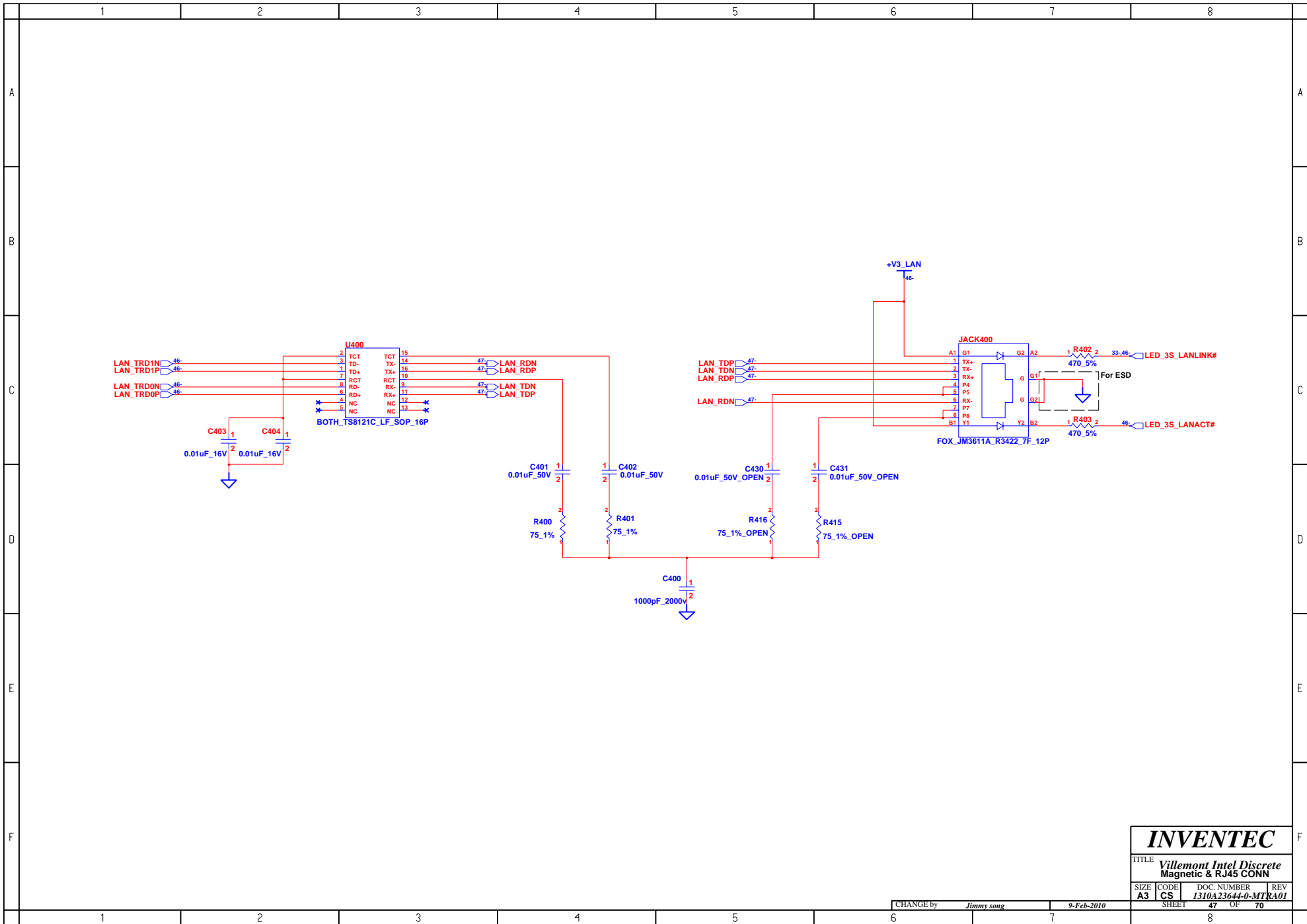

INVENTEC

TITLE: **Villemont Intel Discrete Magnetic & RJ45 CONN**

SIZE	CODE	DOC. NUMBER	REV
A3	CS	1310A23644-0-MTR	KA01

CHANGE by Jimmy song 9-Feb-2010

SHEET 47 OF 70

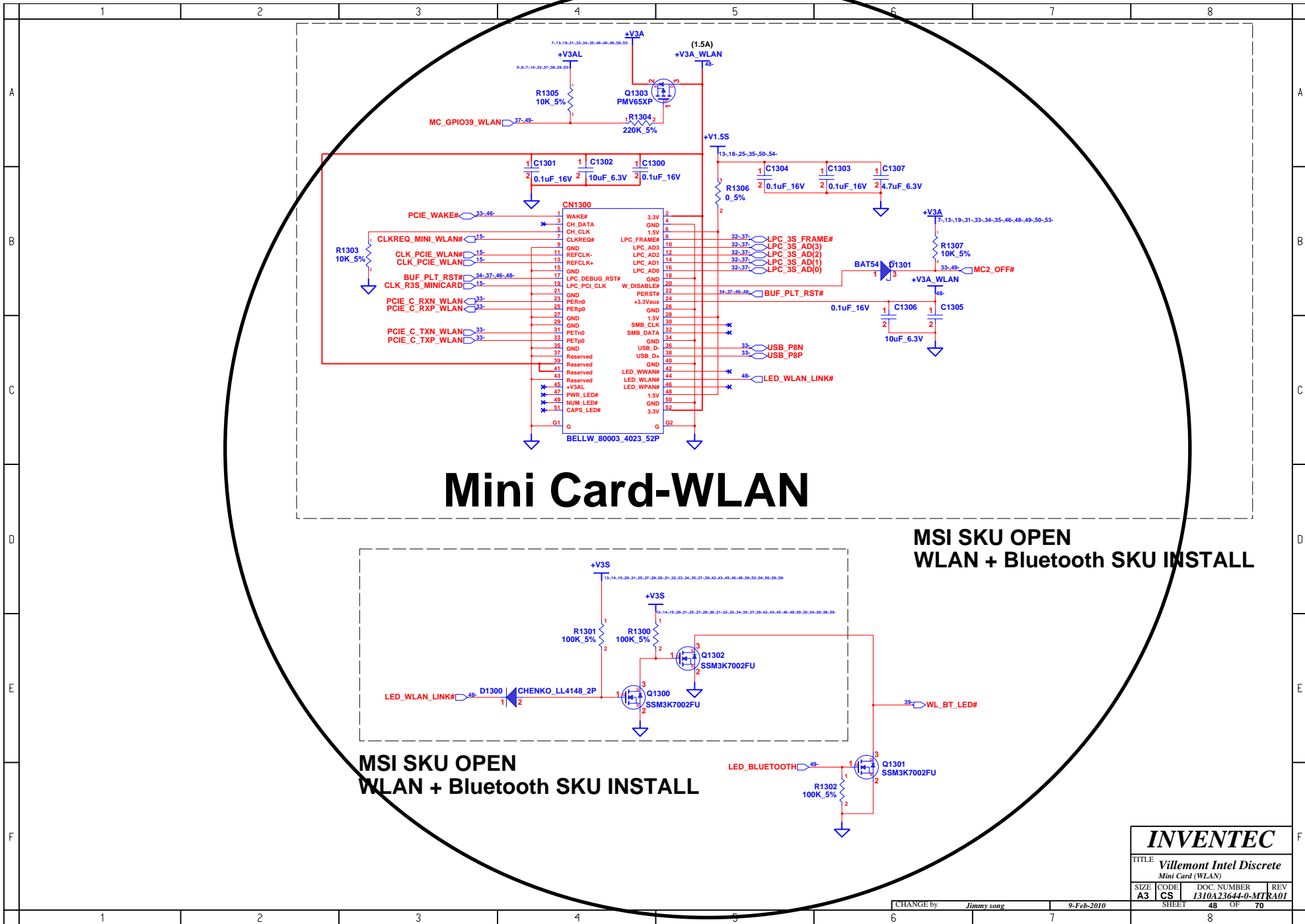

INVENTEC			
TITLE <i>Villemont Intel Discrete Mini Card (WLAN)</i>			
SIZE A3	CODE CS	DOC. NUMBER <i>1310A23644-0-MTR</i>	REV RA01
CHANGE by <i>Jimmy song</i>		9-Feb-2010	
SHEET 48		OF 70	

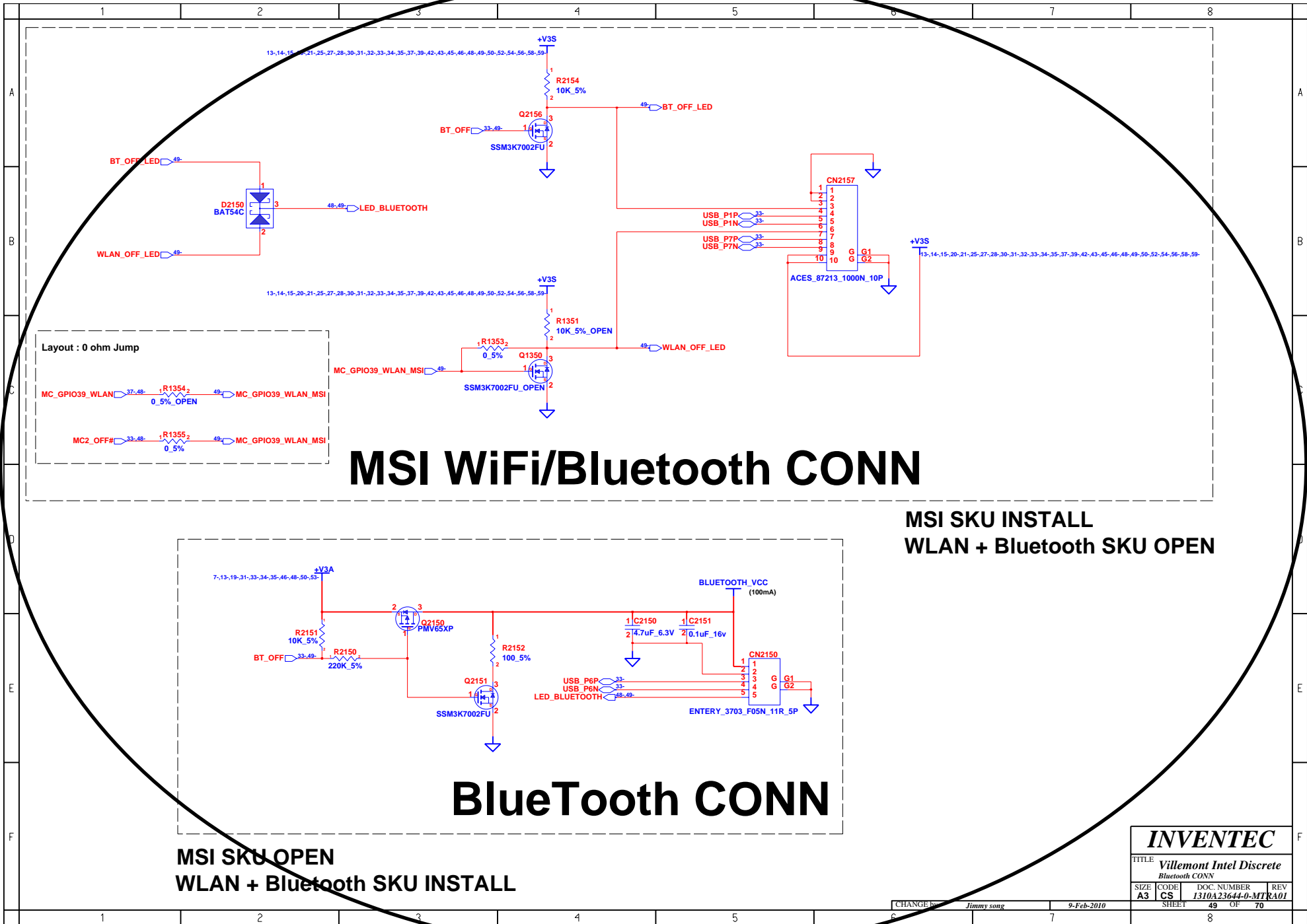

MSI WiFi/Bluetooth CONN

MSI SKU INSTALL
WLAN + Bluetooth SKU OPEN

BlueTooth CONN

MSI SKU OPEN
WLAN + Bluetooth SKU INSTALL

INVENTEC			
TITLE Villemont Intel Discrete Bluetooth CONN			
SIZE A3	CODE CS	DOC. NUMBER I310A23644-0-MTR	REV A01
CHANGE BY Jimmy song		9-Feb-2010	
SHEET 49		OF 70	

BLANK

INVENTEC			
TITLE <i>Villemont Intel Discrete</i>			
BLANK			
SIZE	CODE	DOC. NUMBER	REV
A3	CS	1310A23644-0-MT	KA01
CHANGE by <i>Jimmy song</i>		9-Feb-2010	SHEET 51 OF 70

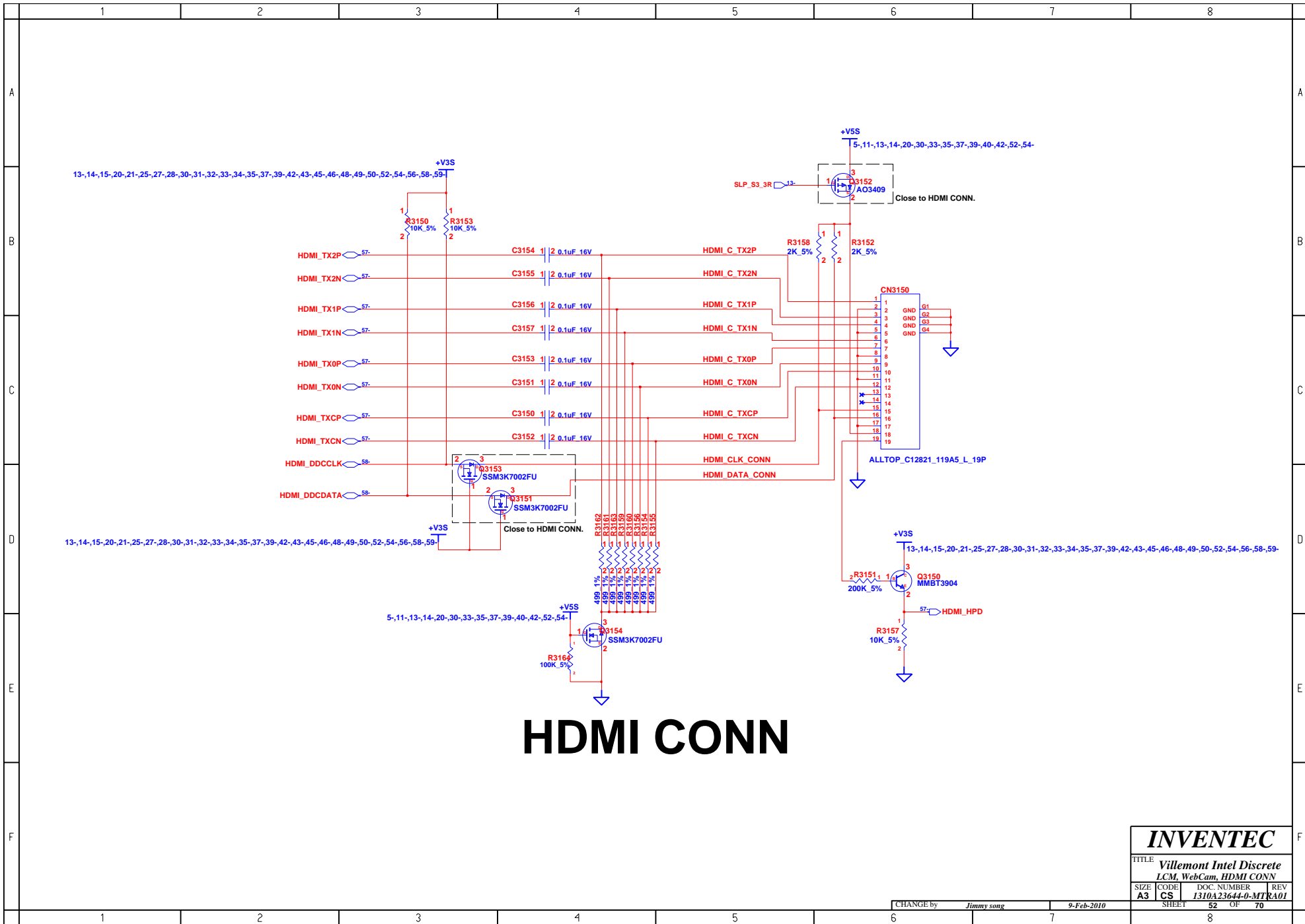

INVENTEC			
TITLE <i>Villemont Intel Discrete LCM, WebCam, HDMI CONN</i>			
SIZE A3	CODE CS	DOC NUMBER <i>1310A23644-0-MTR</i>	REV A01
CHANGE by <i>Jimmy song</i>		9-Feb-2010	
SHEET		52 OF 70	

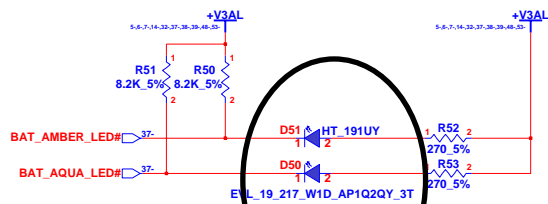

Battery Charge LED

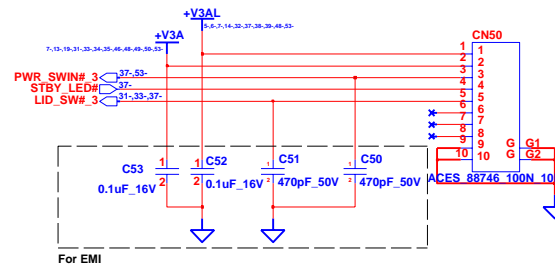
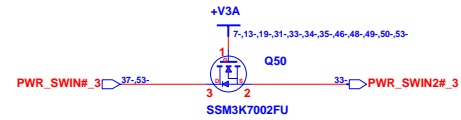

Switch B/B CONN

INVENTEC			
TITLE Villemont Intel Discrete LEDs			
SIZE A3	CODE CS	DOC. NUMBER 1310A23644-0-MTR	REV RA01
CHANGE by <i>Jimmy song</i>		9-Feb-2010	
SHEET 53		OF 70	

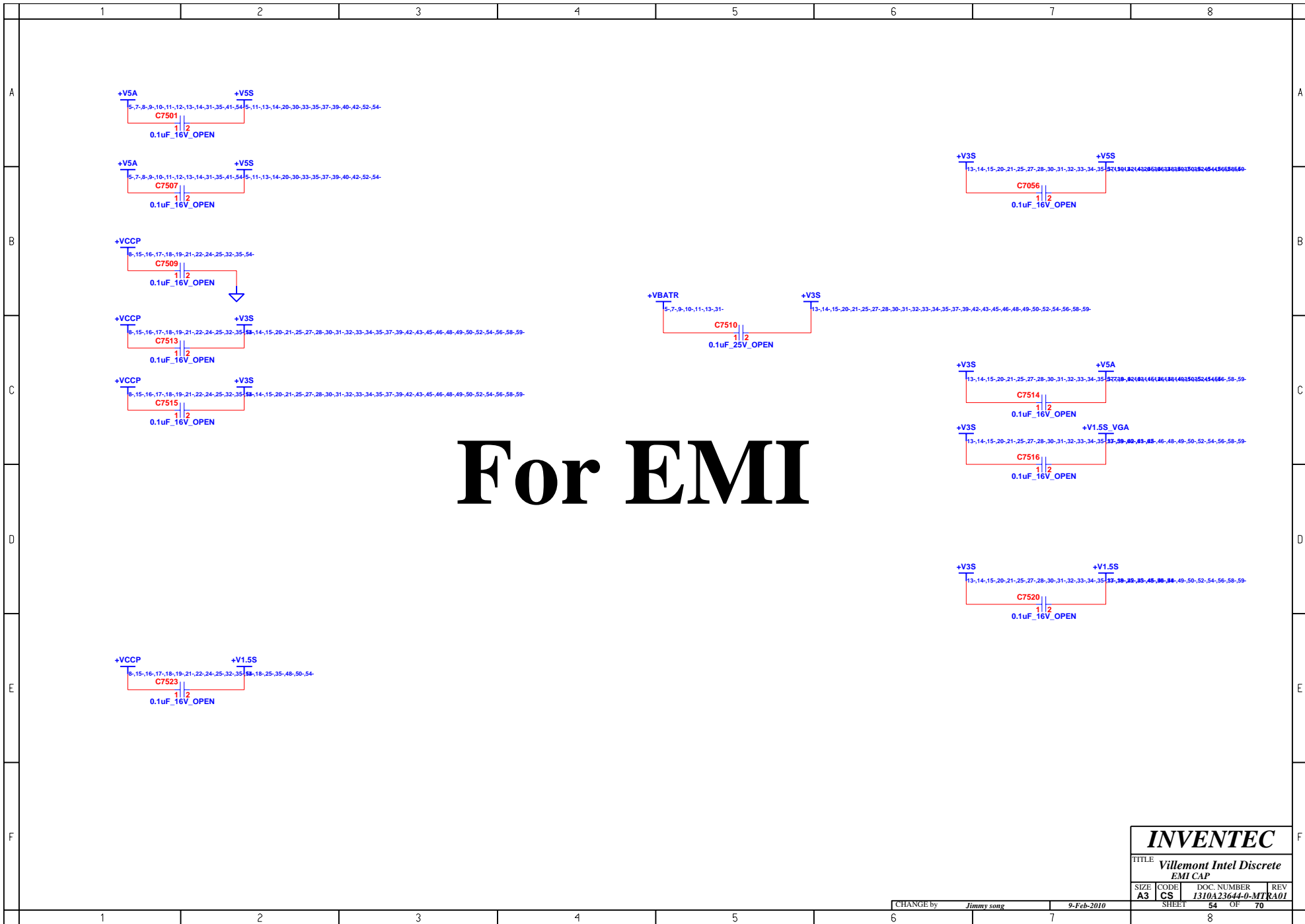

INVENTEC			
TITLE Villemont Intel Discrete EMI CAP			
SIZE A3	CODE CS	DOC. NUMBER 1310A23644-0-MTR	REV A01
CHANGE by <i>Jimmy song</i>		9-Feb-2010	
SHEET 54		OF 70	

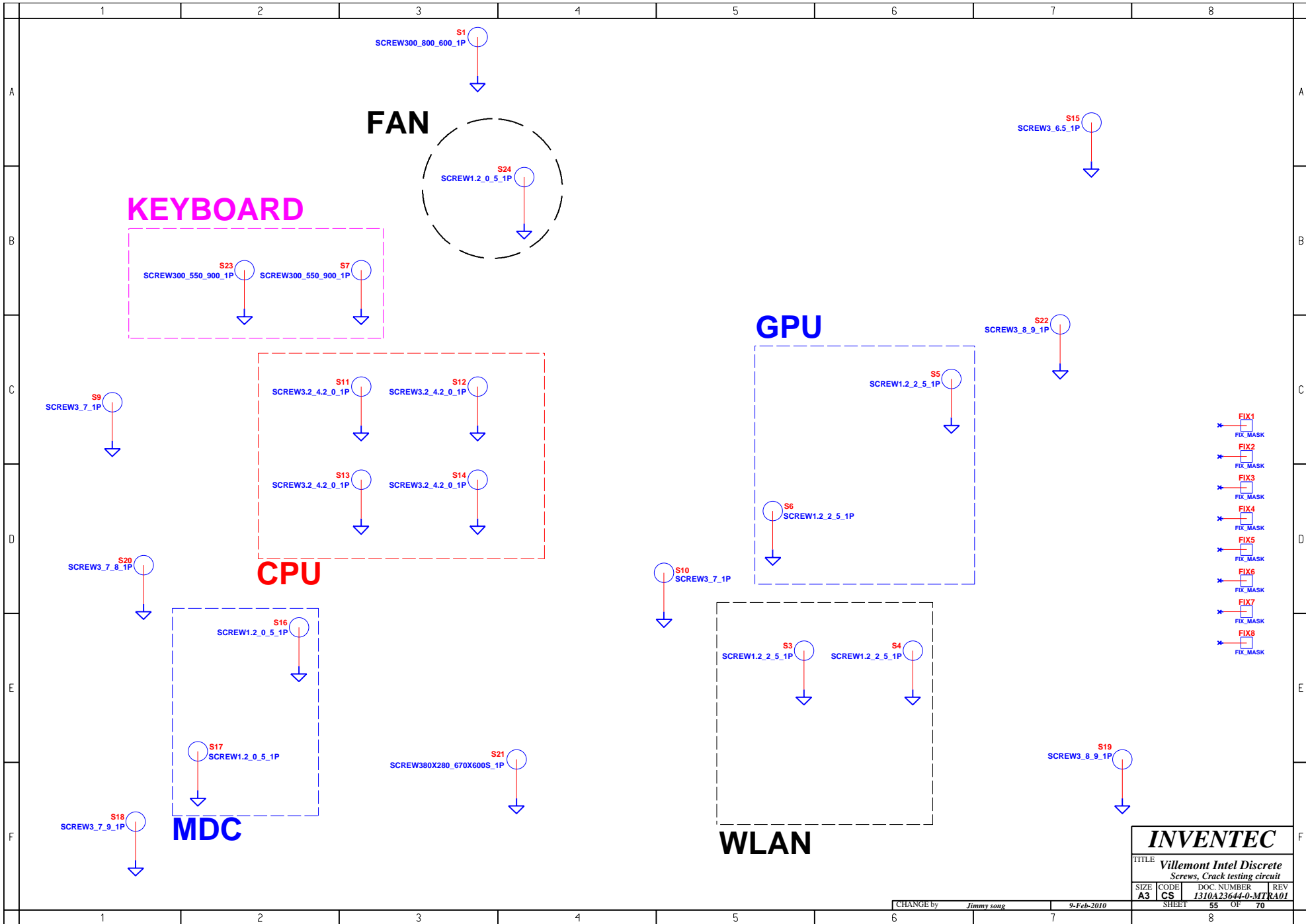

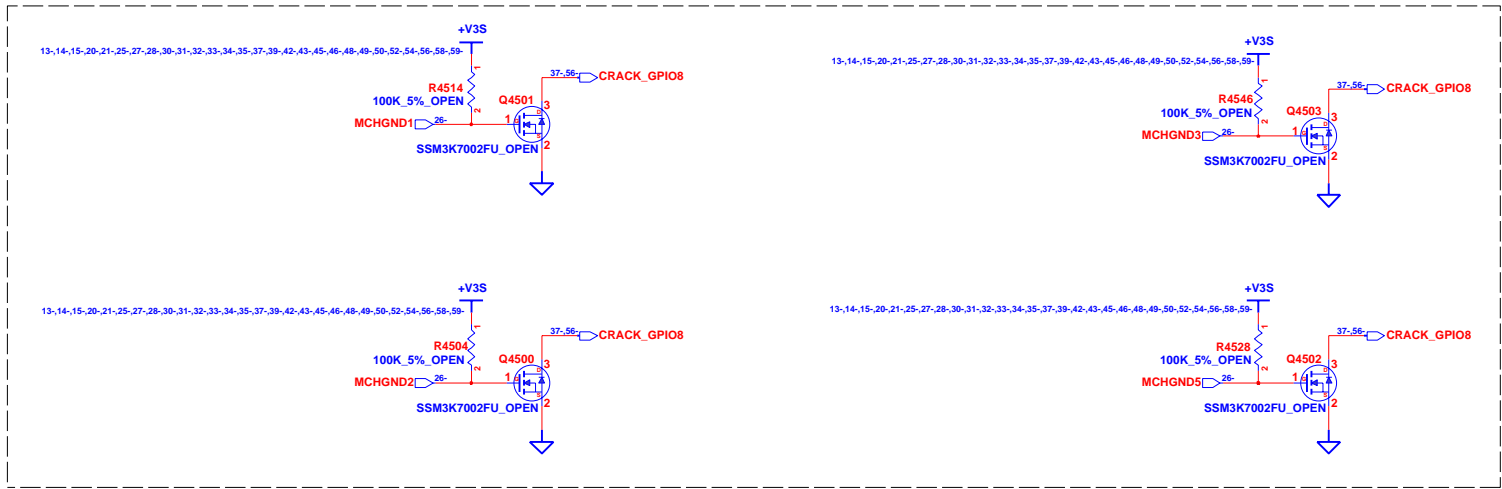

NB Cantiga Side

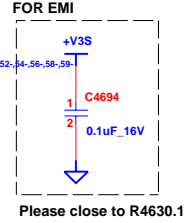
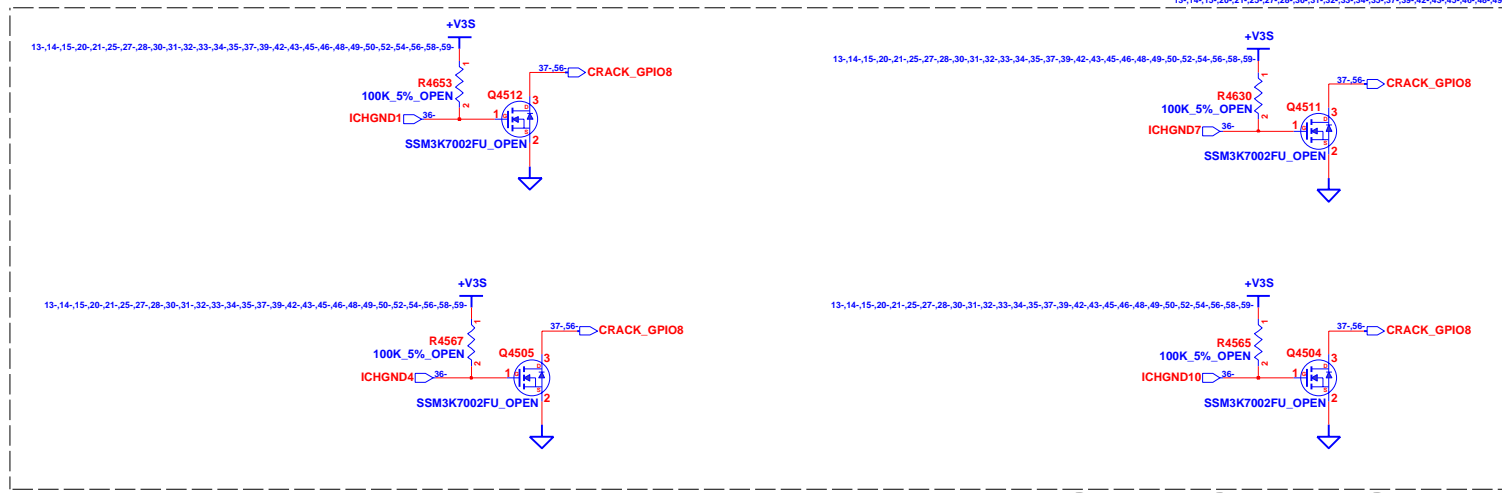

For Crack Test

SB ICH9 Side

INVENTEC			
TITLE <i>Villemont Intel Discrete</i>			
Crack testing circuit			
SIZE	CODE	DOC NUMBER	REV
A3	CS	1310A23644-0-MT	RA01
CHANGE by <i>Jimmy song</i>		9-Feb-2010	
SHEET 56		OF 70	

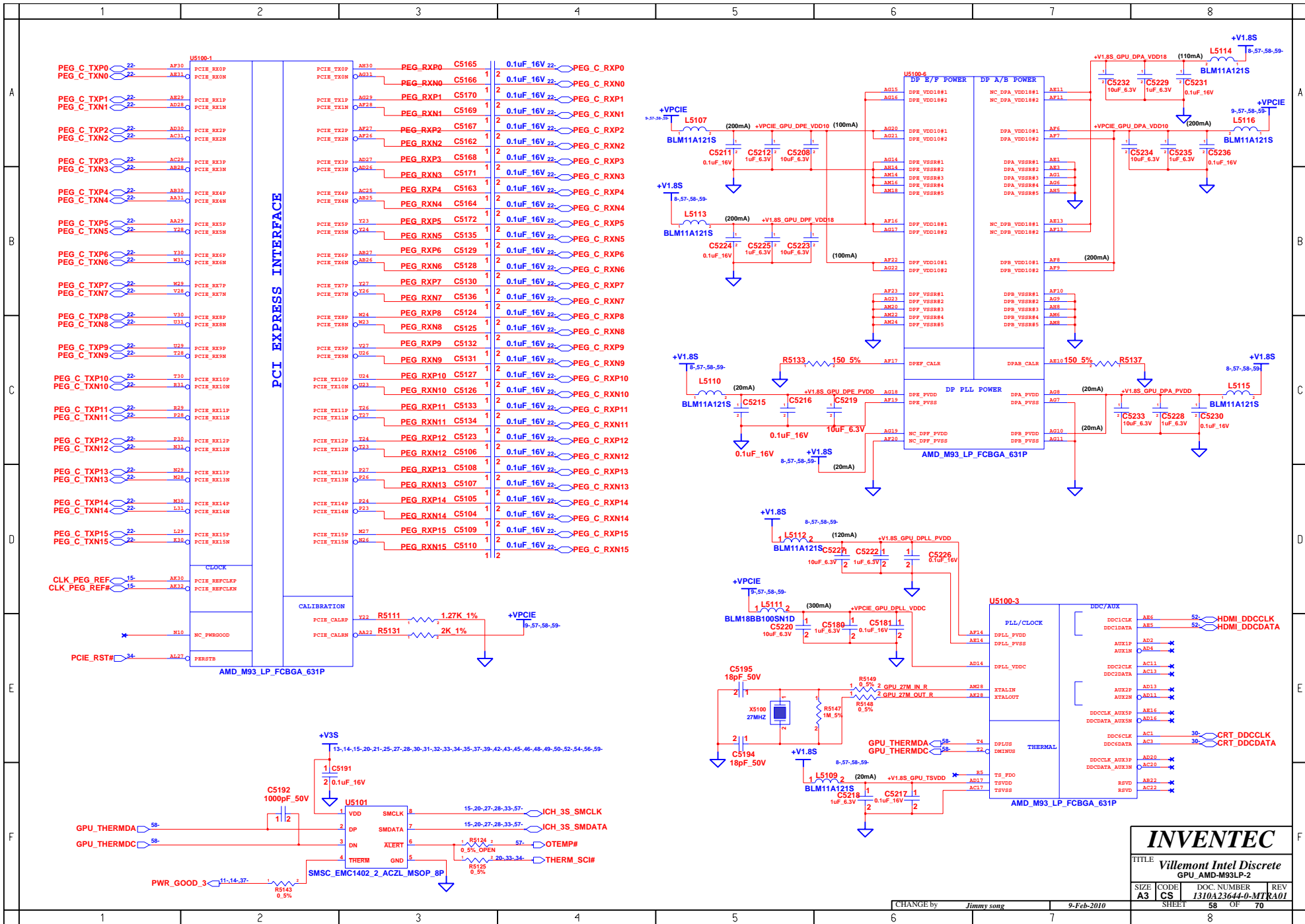

INVENTEC			
TITLE Villemont Intel Discrete GPU_AMD-M93LP-2			
SIZE A3	CODE CS	DOC. NUMBER 1310A23644-0-MTR	REV KA01
CHANGE by <i>Jimmy song</i>		9-Feb-2010	
SHEET 58		OF 70	

http://sualaptop365.com/fix/vn

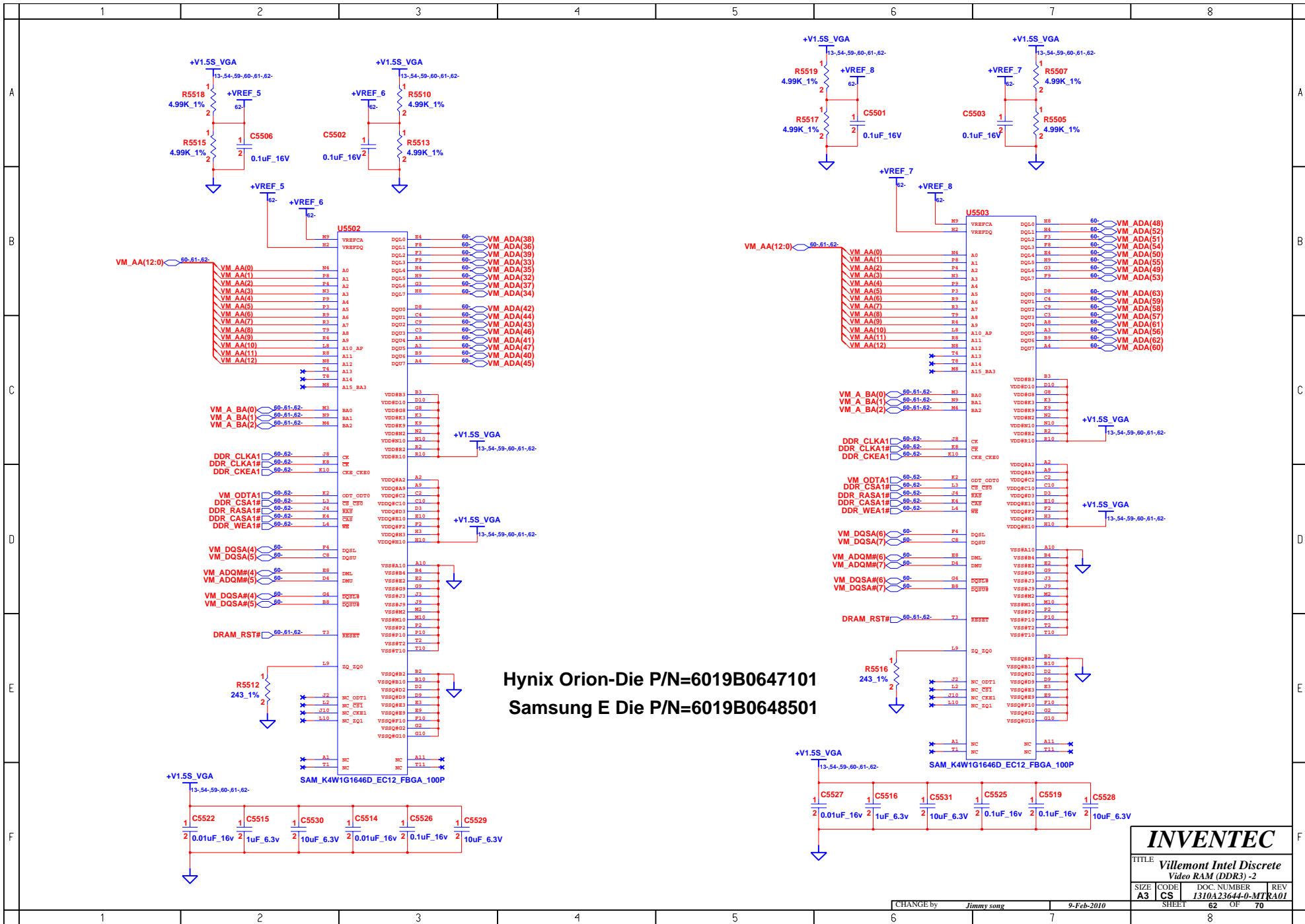

Hynix Orion-Die P/N=6019B0647101
 Samsung E Die P/N=6019B0648501

INVENTEC			
TITLE Villemont Intel Discrete Video RAM (DDR3) -2			
SIZE A3	CODE CS	DOC. NUMBER 1310A23644-0-MTR	REV RA01
SHEET 62		OF 70	

CHANGE by *Jimmy song* 9-Feb-2010

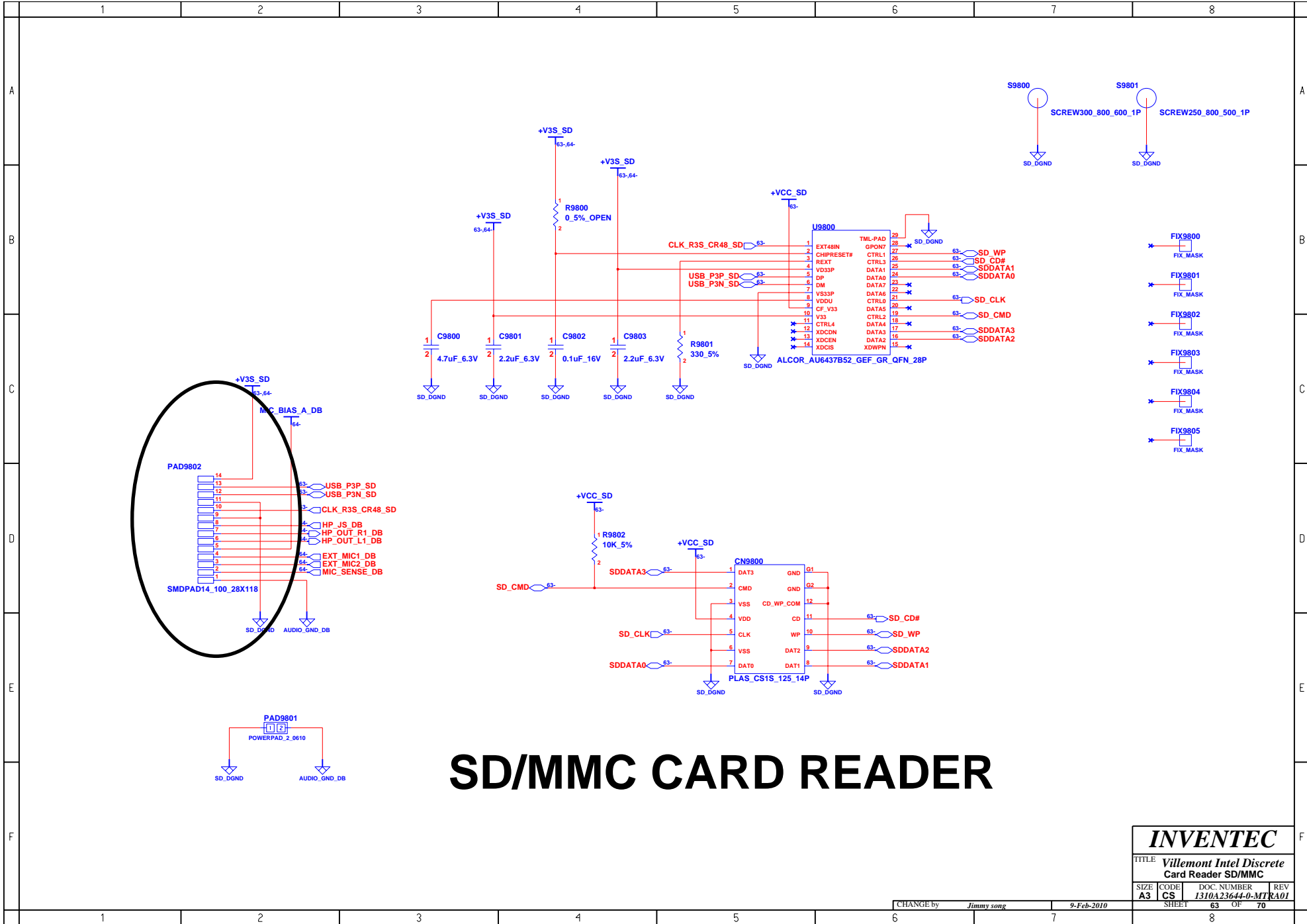

SD/MMC CARD READER

INVENTEC			
TITLE <i>Villemont Intel Discrete Card Reader SD/MMC</i>			
SIZE A3	CODE CS	DOC. NUMBER <i>1310A23644-0-MTR</i>	REV RA01
CHANGE by <i>Jimmy song</i>		9-Feb-2010	
SHEET 63		OF 70	

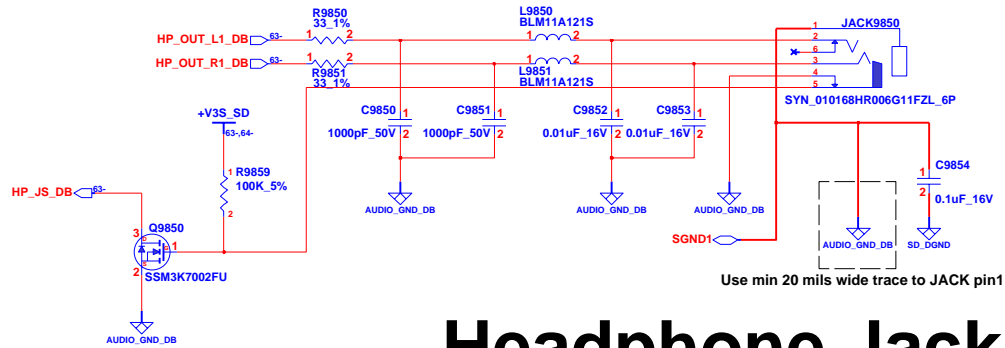

Headphone Jack

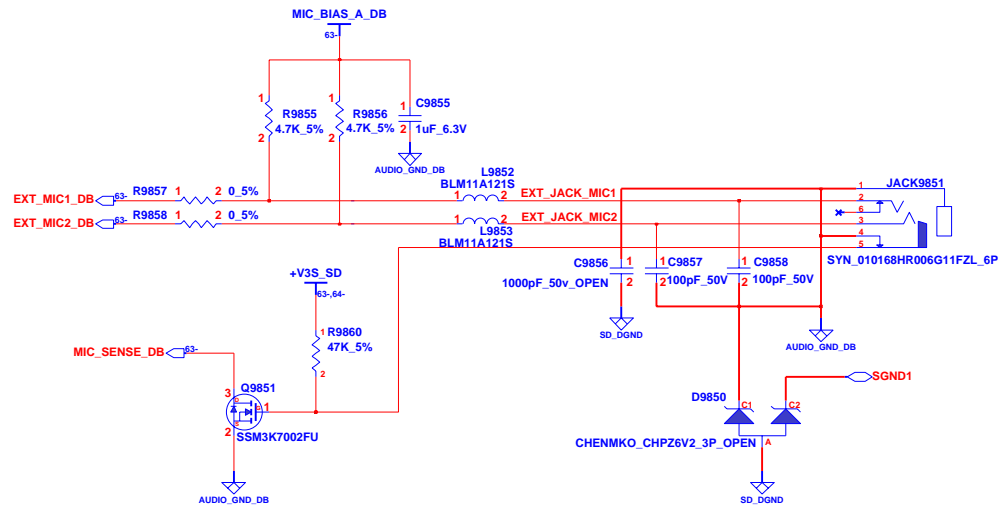

MIC Jack

INVENTEC			
TITLE Villemont Intel Discrete			
Headphone & MIC			
SIZE A3	CODE CS	DOC. NUMBER 1310A23644-0-MT	REV RA01
CHANGE by <i>Jimmy song</i>		9-Feb-2010	SHEET 64 OF 70

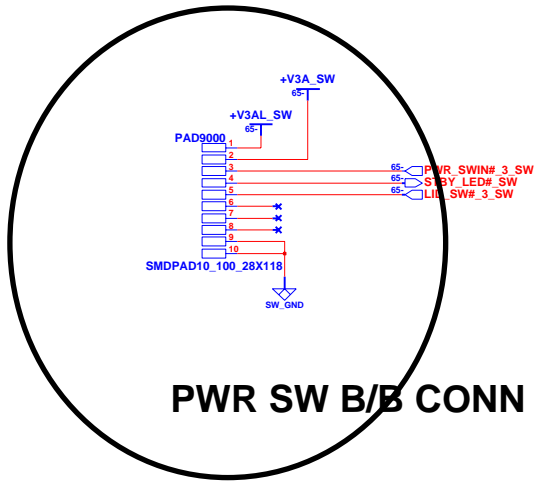

PWR SW B/B CONN

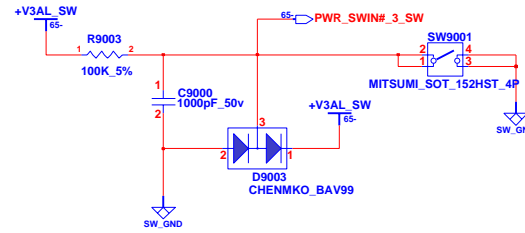

Power Button

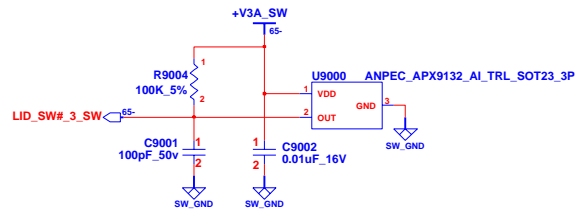
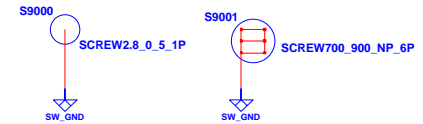

LID Switch

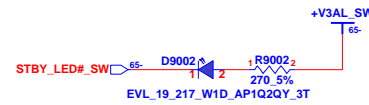

Power / Standby LED

Power Button & LID Switch Board

INVENTEC			
TITLE Villemont Intel Discrete			
Power button & LID switch			
SIZE A3	CODE CS	DOC NUMBER 1310A23644-0-MTR	REV RA01
CHANGE by <i>Jimmy song</i>		9-Feb-2010	SHEET 65 OF 70

BLANK

14" ODD Extend Board

INVENTEC			
TITLE Villemont Intel Discrete			
<small>14" ODD EXT/B</small>			
SIZE A3	CODE CS	DOC. NUMBER 1310A23644-0-MTR	REV A01
CHANGE by <i>Jimmy song</i>		9-Feb-2010	
SHEET 66		OF 70	

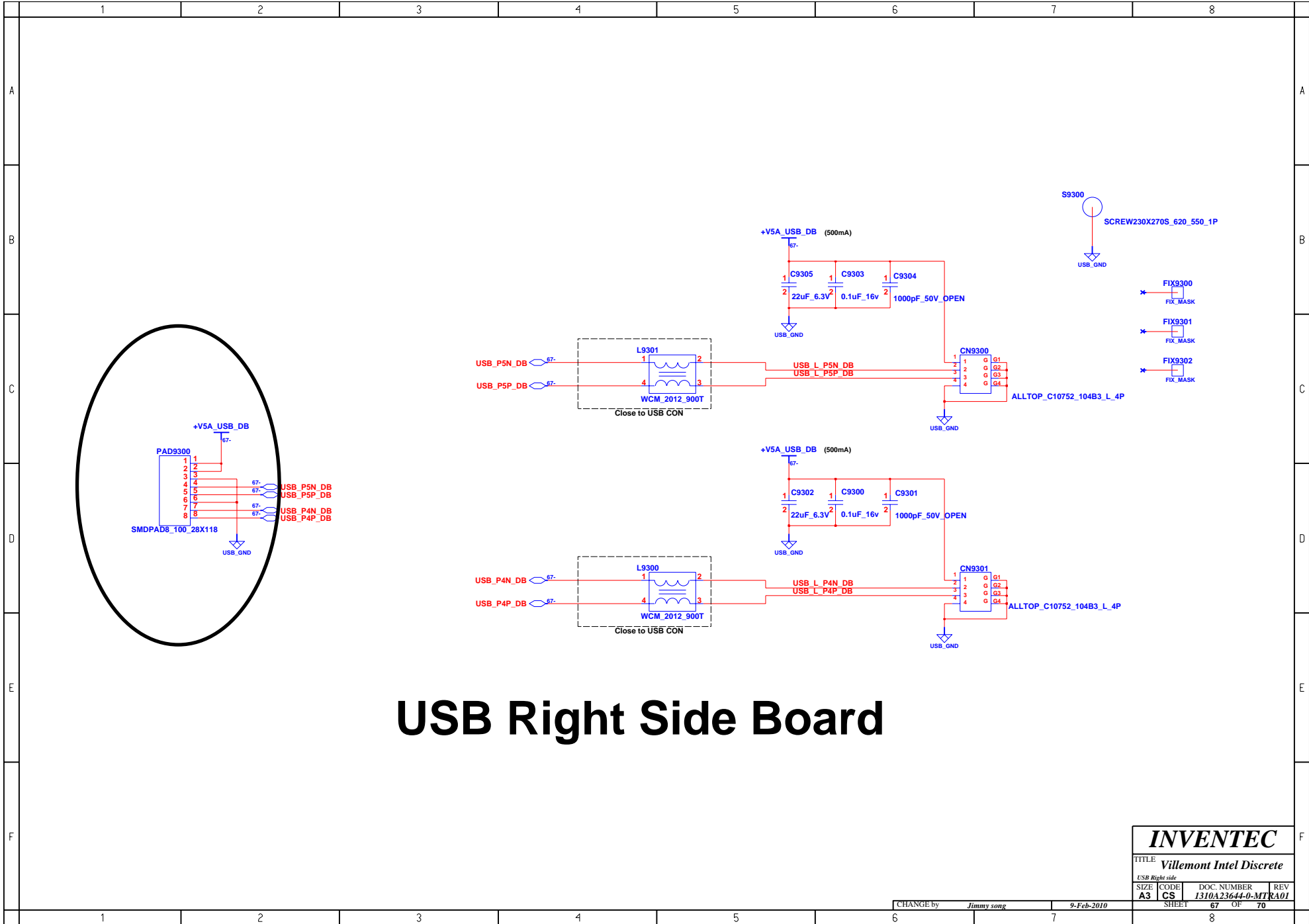

USB Right Side Board

INVENTEC			
TITLE Villemont Intel Discrete			
USB Right side			
SIZE A3	CODE CS	DOC. NUMBER 1310A23644-0-MTR	REV A01
CHANGE by <i>Jimmy song</i>		9-Feb-2010	
SHEET 67		OF 70	

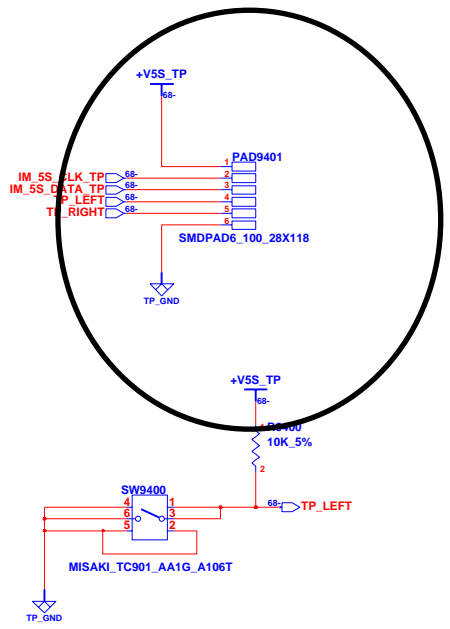

LEFT BUTTON

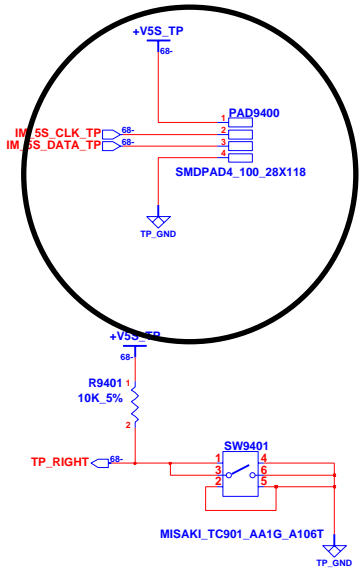

RIGHT BUTTON

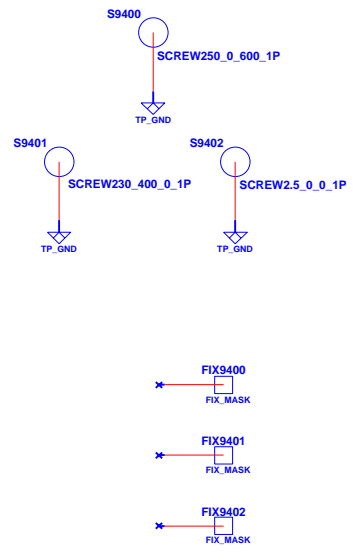

PICK Button Board

INVENTEC			
TITLE Villemont Intel Discrete Pick button			
SIZE A3	CODE CS	DOC. NUMBER 1310A23644-0-MTR	REV A01
CHANGE by Jimmy song		DATE 27-Sep-2003	SHEET 68 OF 70

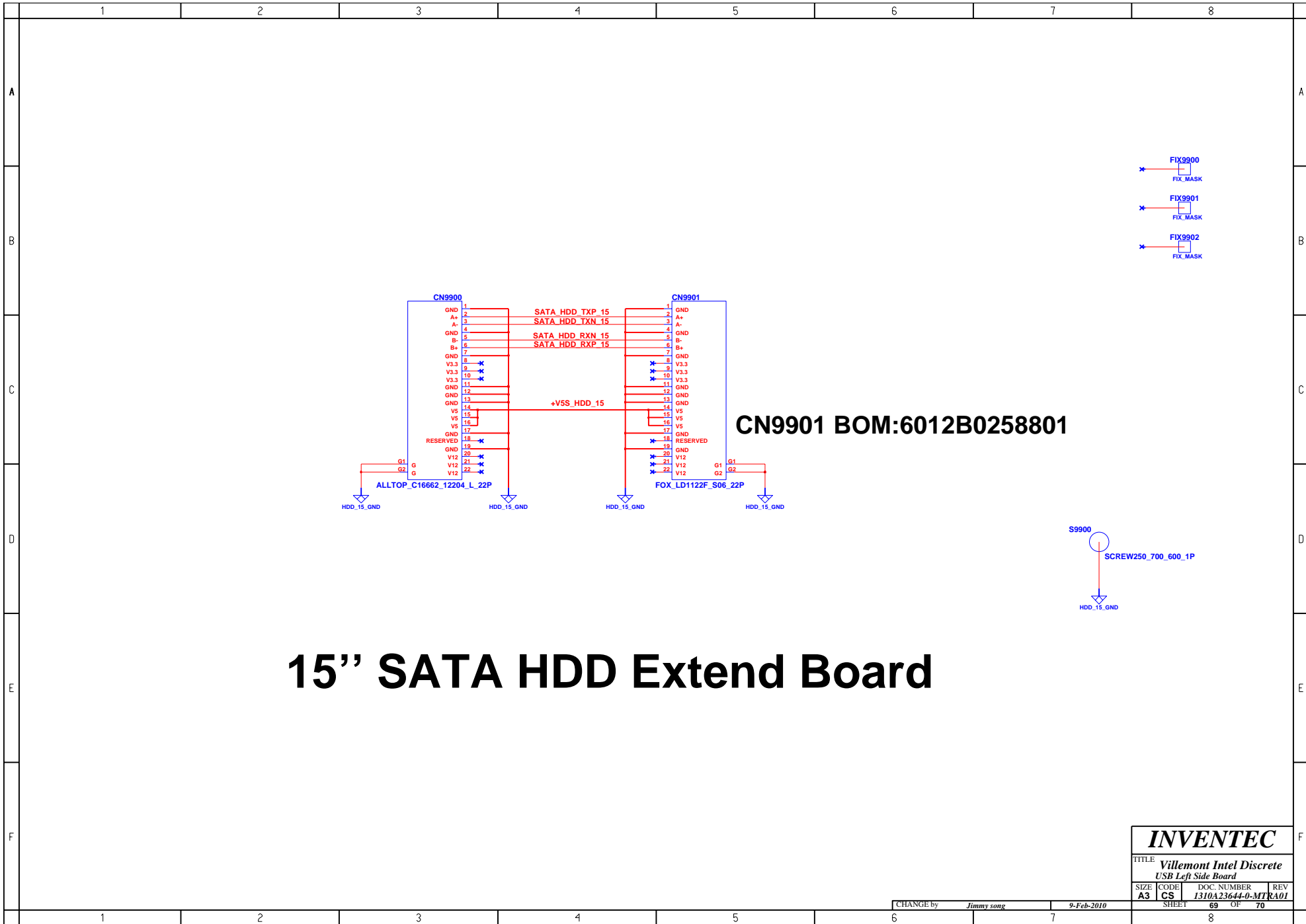

15" SATA HDD Extend Board

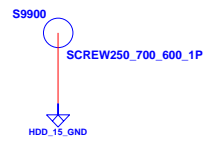
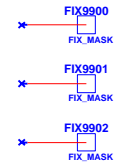

INVENTEC			
TITLE <i>Villemont Intel Discrete USB Left Side Board</i>			
SIZE A3	CODE CS	DOC. NUMBER 1310A23644-0-MTR	REV KA01
CHANGE by <i>Jimmy song</i>		9-Feb-2010	SHEET 69 OF 70

