

Milwaukee 10A

CS BUILD

2007 0709

DATE	CHANGE NO.	REV

<http://laptop-motherboard-schematic.blogspot.com>

DRAWER	EE	DATE	POWER	DATE	INVENTEC			
DESIGN					TITLE MW10A			
CHECK					SIZE = 3			
RESPONSIBLE					CODE A3 CS DOC. NUMBER Model No REV X01			
					SHEET 1 OF 54			
					DATE: XXXX-XXXX-XX			
					P/N: XXXXXXXXXXXX			

TABLE OF CONTENTS

PAGE	PAGE	PAGE
1.COVER PAGE	29.S/B 1	50.LED(M/B) & HOTKEY/B CONN
2.INDEX	30.S/B 2	51.PICK BUTTON BOARD
3.BLOCK DIAGRAM	31.S/B 3	52.KILL SWITCH& HALL SENSOR
4.POWER SEQUENCE BLOCK	32.S/B 4	53.DRILL HOLE
5-12.SYSTEM POWER	33.CARDBUS CONTROLLER	54.EMI
13.CLOCK GENERATOR	34.5 IN 1 CARD SLOT & 1394	
14.CPU 1	35.EXPRESS CARD CONN	
15.CPU 2	36.LAN CONTROLLER	
16.CPU 3	37.RJ45 & TRANSFORMER	
17.CPU 4	38.WLAN & HD_DVD	
18.FAN & THERMAL CONTROLLER	39.SATA HDD1 CONN & SATA HDD2 CONN	
19.N/B 1	40.FELICA & FINGER PRINTER & CAMERA CONN	
20.N/B 2	41.ODD CONN	
21.N/B 3	42.USB CONN	
22.N/B 4	43.BLUE TOOTH CONN	
23.DDR2 DIMM0	44.KBC	
24.DDR2 DIMM1	45.K/B & TP/B CONN	
25.DDR DAMPING	46.CIR	
26.CRT CONN	47.AZALIA CODEC	
27.S-VIDEO CONN	48.AUDIO AMP & MIC & HP	
28.LCM CONN	49.MDC 1.5 CONN	

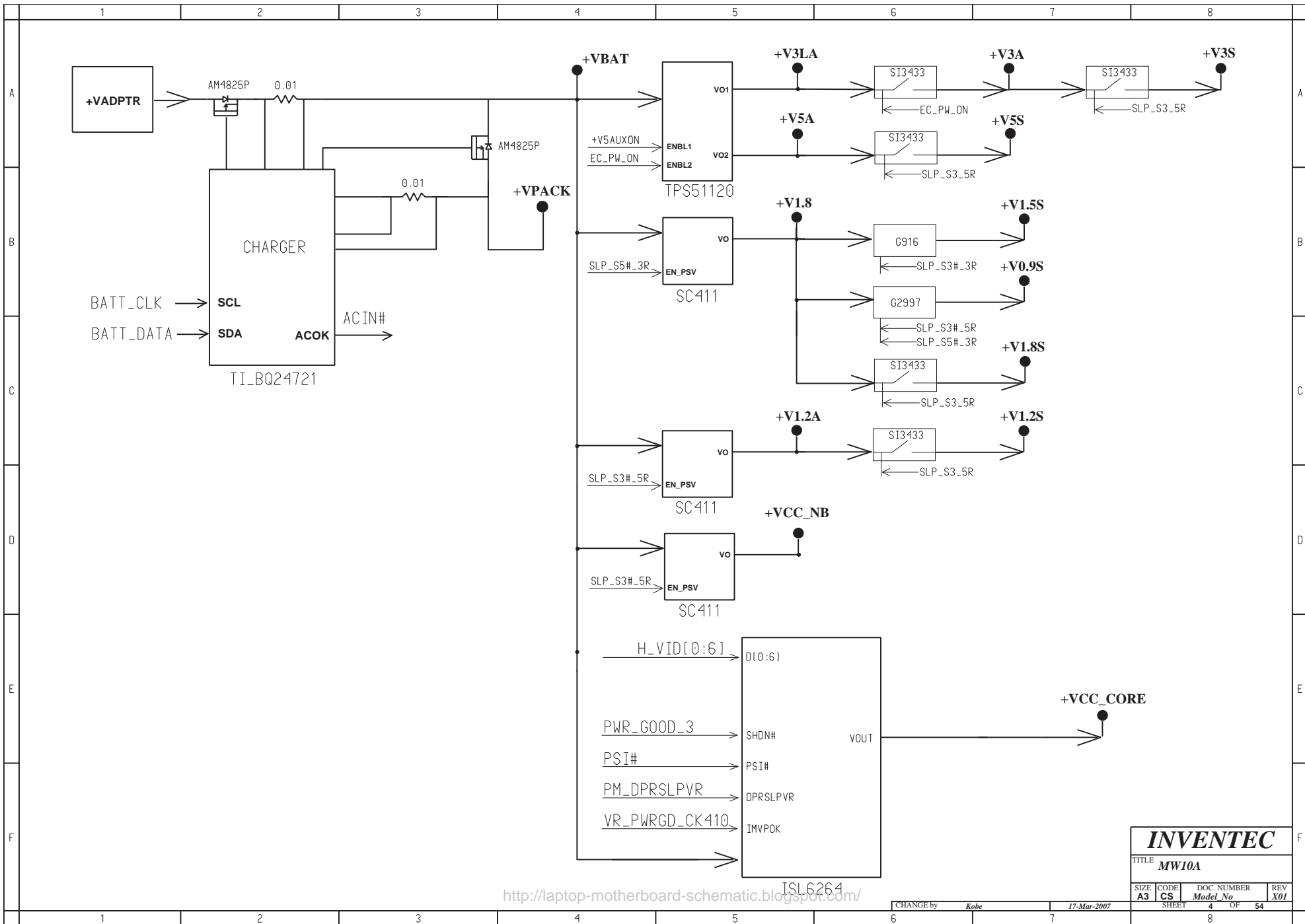

<http://laptop-motherboard-schematic.blogspot.com/> ISL6264

INVENTEC			
TITLE MW10A			
SIZE A3	CODE CS	DOC. NUMBER <i>Model No</i>	REV X01
CHANGE by <i>Kobe</i>		17-Mar-2007	
SHEET 4		OF 54	

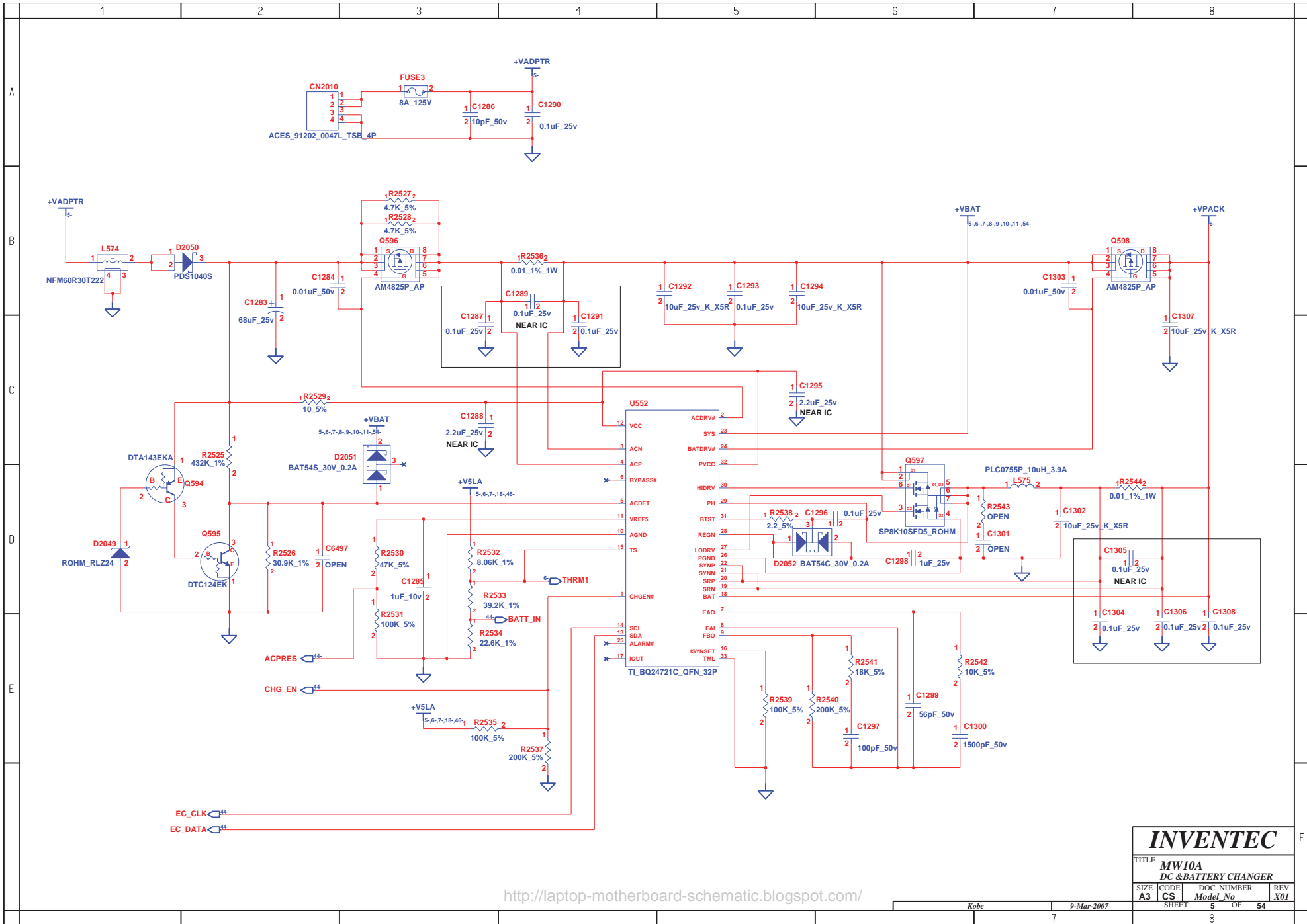

<http://laptop-motherboard-schematic.blogspot.com/>

INVENTEC

TITLE
MW10A
 DC & BATTERY CHANGER

SIZE	CODE	DOC. NUMBER	REV
A3	CS	Model No	X01

9-Mar-2007
 SHEET 5 OF 54

Kobe

7

8

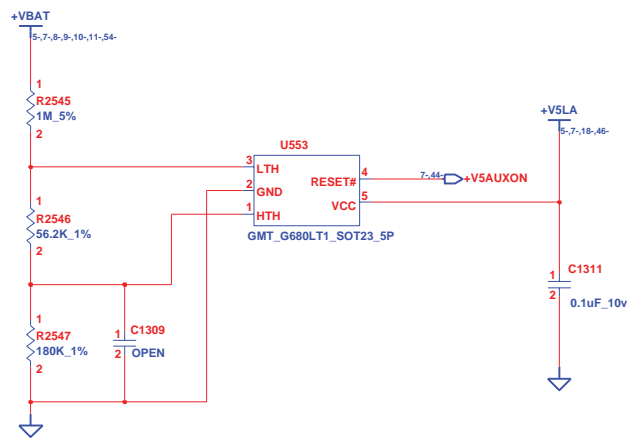
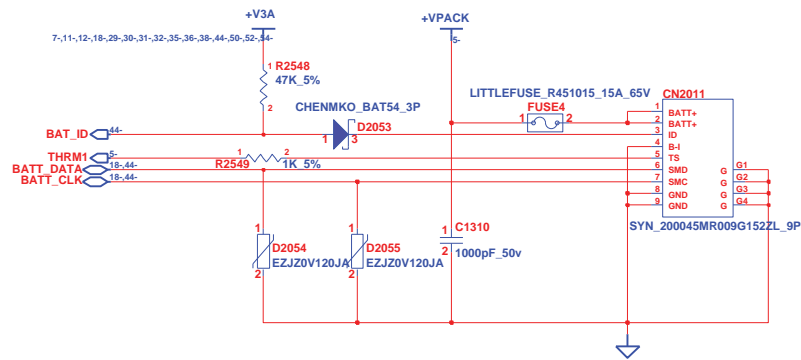

<http://laptop-motherboard-schematic.blogspot.com/>

INVENTEC

TITLE			
MW10A			
BATTERY CONN			
SIZE	CODE	DOC. NUMBER	REV
A3	CS	Model No	X01

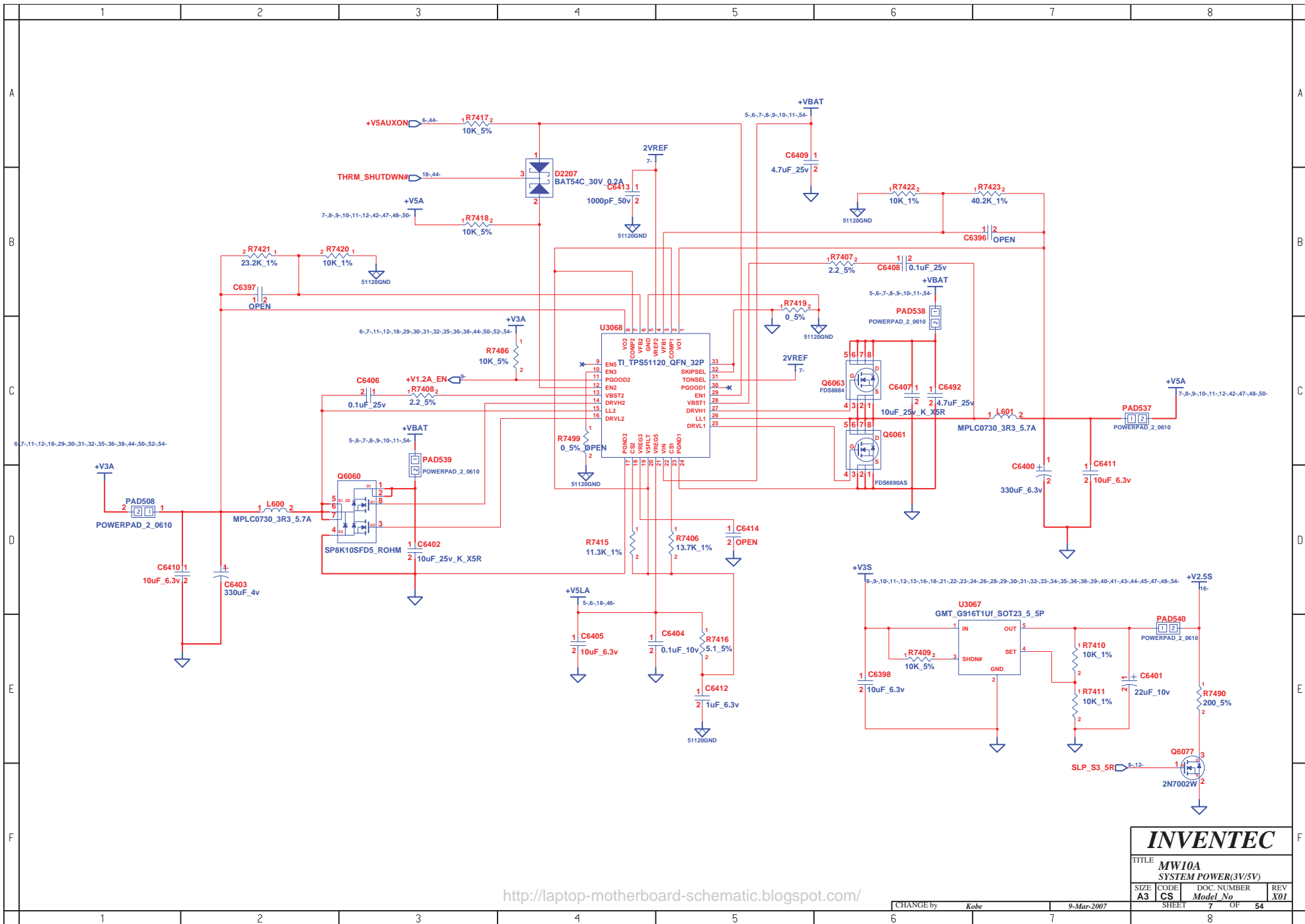

<http://laptop-motherboard-schematic.blogspot.com/>

INVENTEC

TITLE			
MW10A SYSTEM POWER(3V/5V)			
SIZE	CODE	DOC. NUMBER	REV
A3	CS	Model No	X01
CHANGE by		9-Mar-2007	
Kobe		SHEET 7 OF 54	

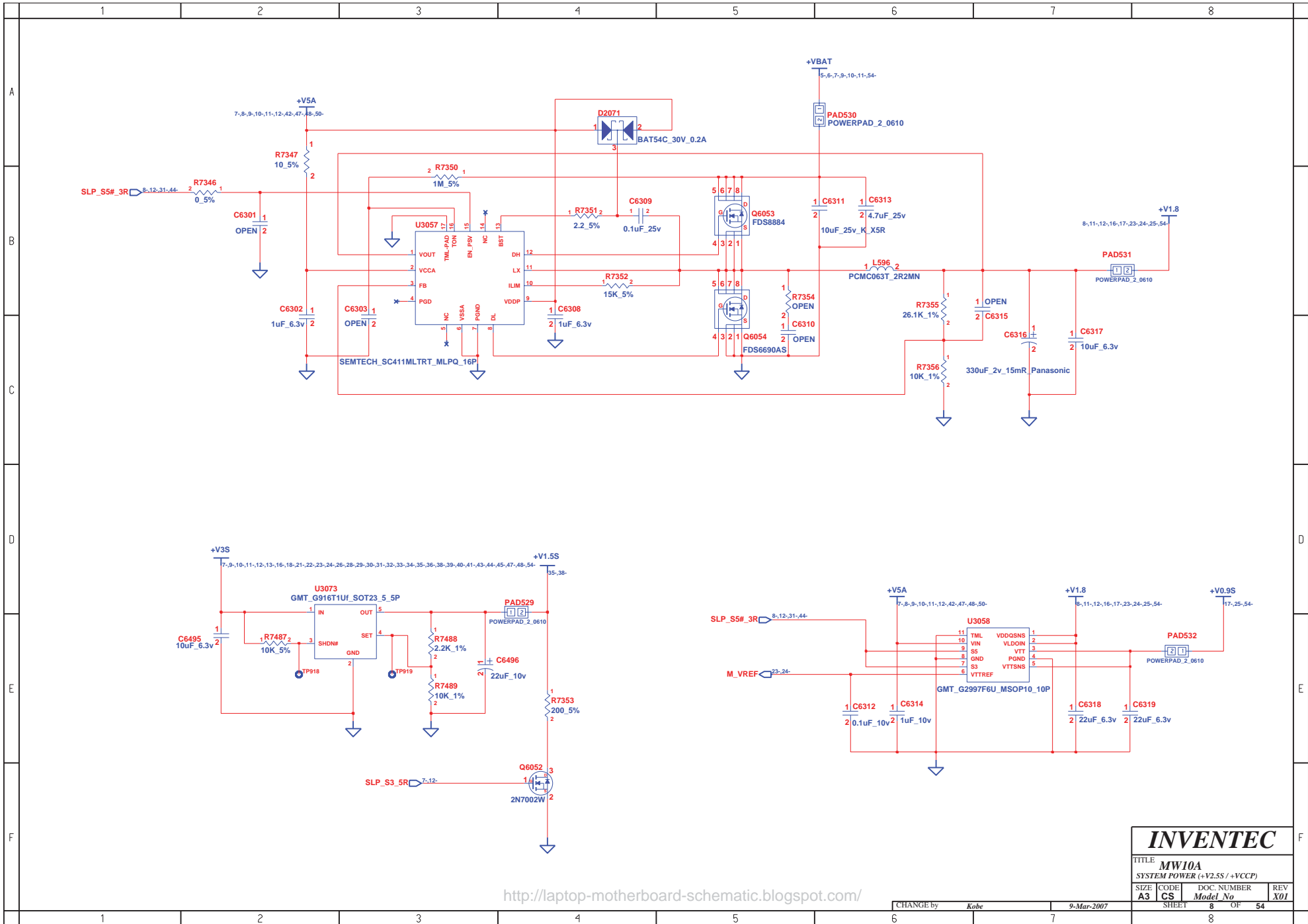

<http://laptop-motherboard-schematic.blogspot.com/>

INVENTEC

TITLE			
MW10A			
SYSTEM POWER (+V2.5S / +VCCP)			
SIZE	CODE	DOC. NUMBER	REV
A3	CS	Model No	X01
CHANGE by			SHEET
Kobe			8 OF 54
9-Mar-2007			8

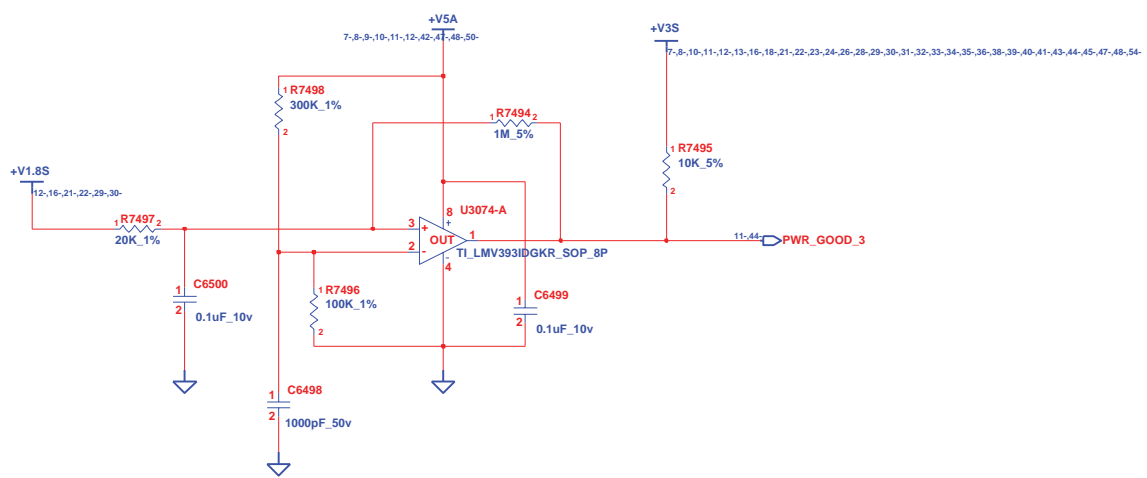
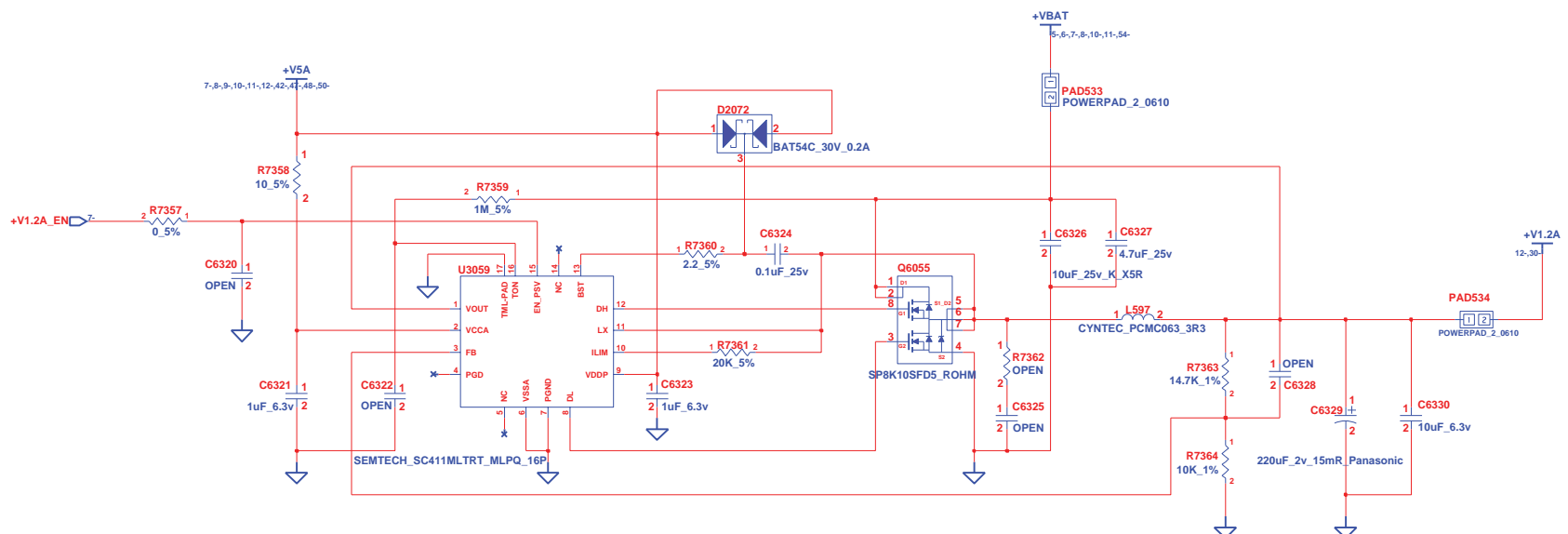

<http://laptop-motherboard-schematic.blogspot.com/>

INVENTEC

TITLE			
MW10A			
SYSTEM POWER(+V1.5S / +V1.8)			
SIZE	CODE	DOC. NUMBER	REV
A3	CS	Model No	X01

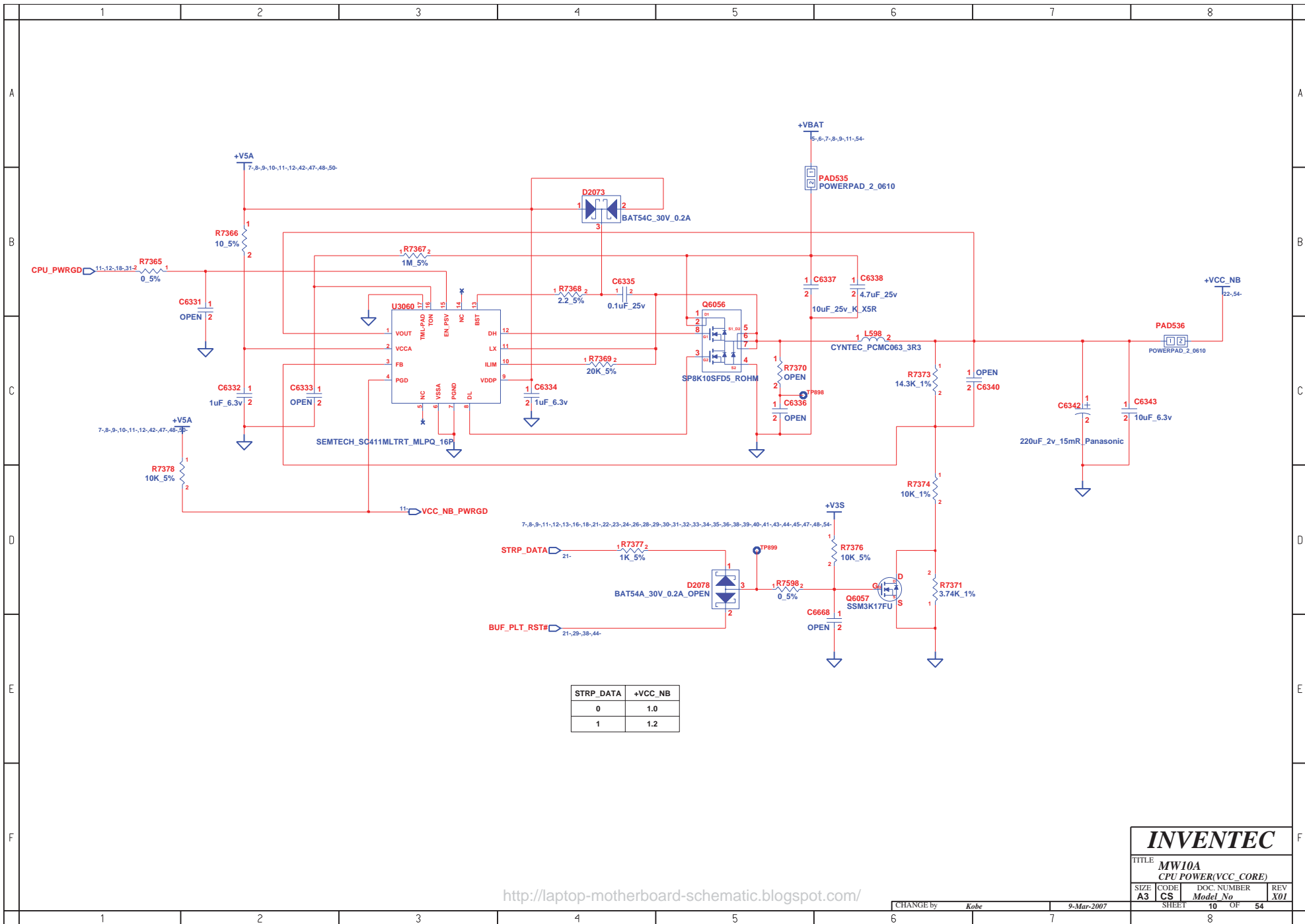

STRP_DATA	+VCC_NB
0	1.0
1	1.2

<http://laptop-motherboard-schematic.blogspot.com/>

INVENTEC

TITLE
MW10A
 CPU POWER(VCC_CORE)

SIZE A3	CODE CS	DOC. NUMBER Model No	REV X01
-------------------	-------------------	-------------------------	-------------------

CHANGE by *Kobe* 9-Mar-2007 SHEET 10 OF 54

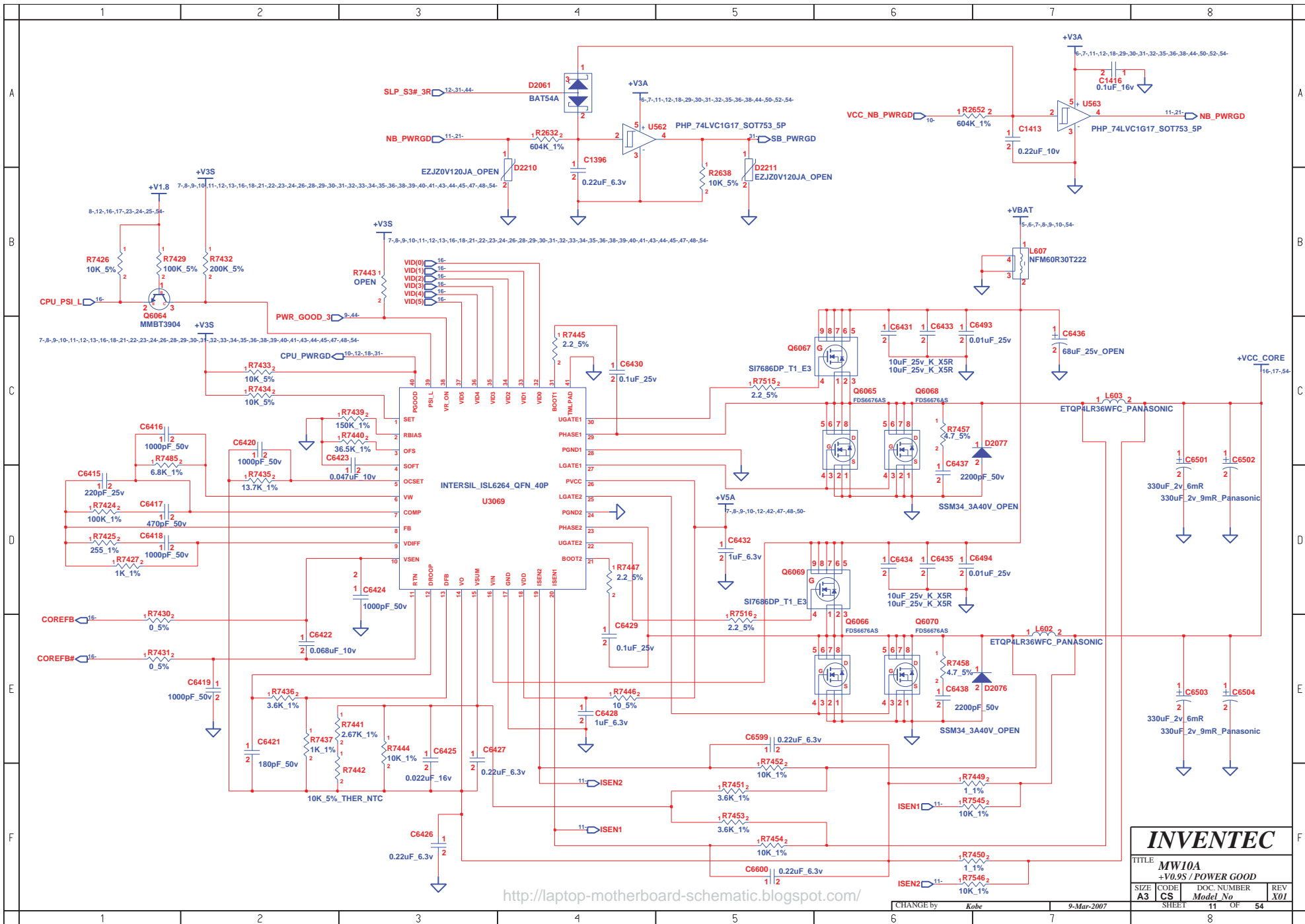

<http://laptop-motherboard-schematic.blogspot.com/>

INVENTEC

TITLE: MW10A
+V0.9S / POWER GOOD

SIZE A3	CODE CS	DOC NUMBER Model No	REV X01
---------	---------	---------------------	---------

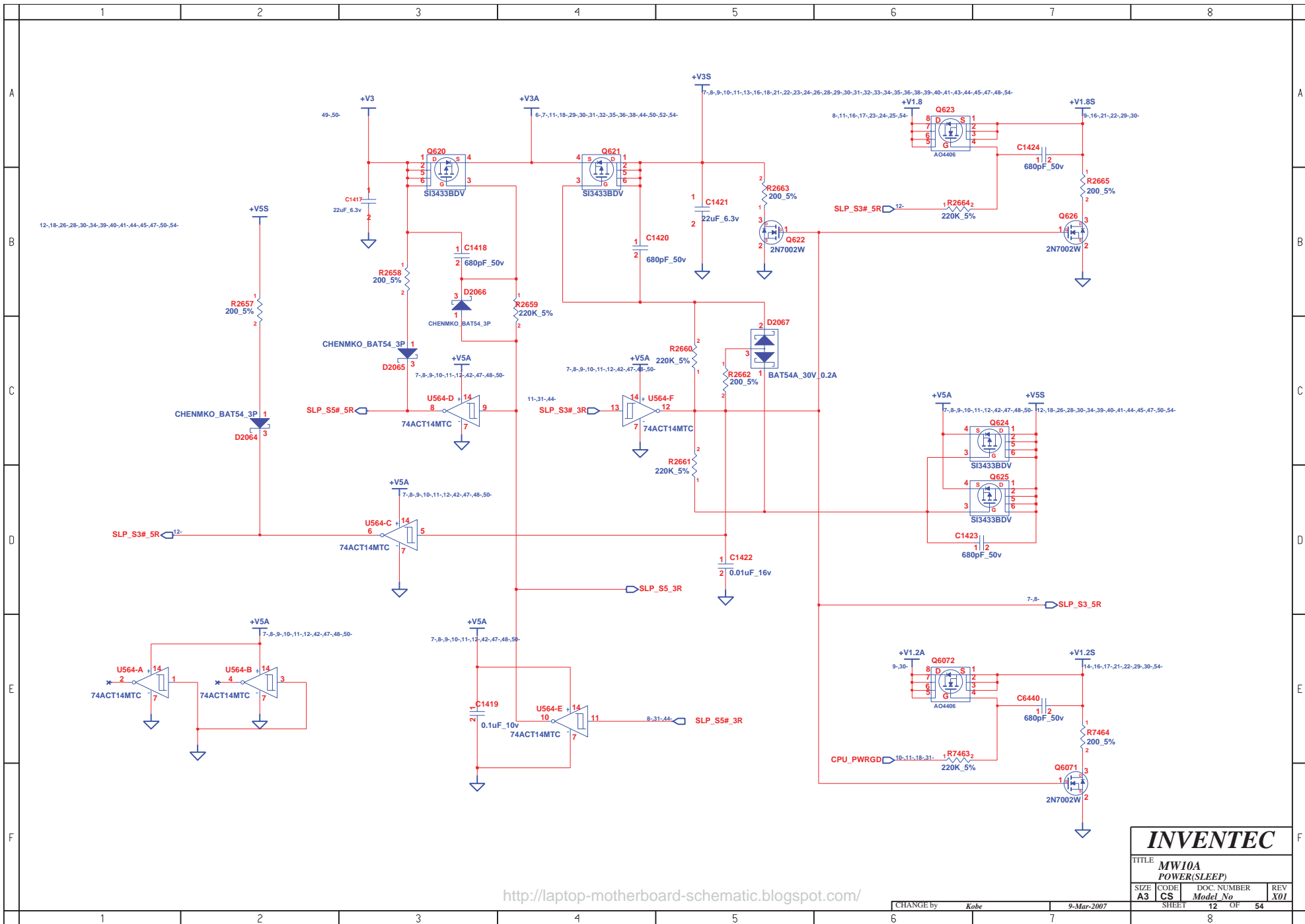

<http://laptop-motherboard-schematic.blogspot.com/>

INVENTEC			
TITLE MW10A POWER(SLEEP)			
SIZE A3	CODE CS	DOC. NUMBER <i>Model No</i>	REV X01
CHANGE by <i>Kobe</i>		9-Mar-2007	
SHEET 12 OF 54		8	

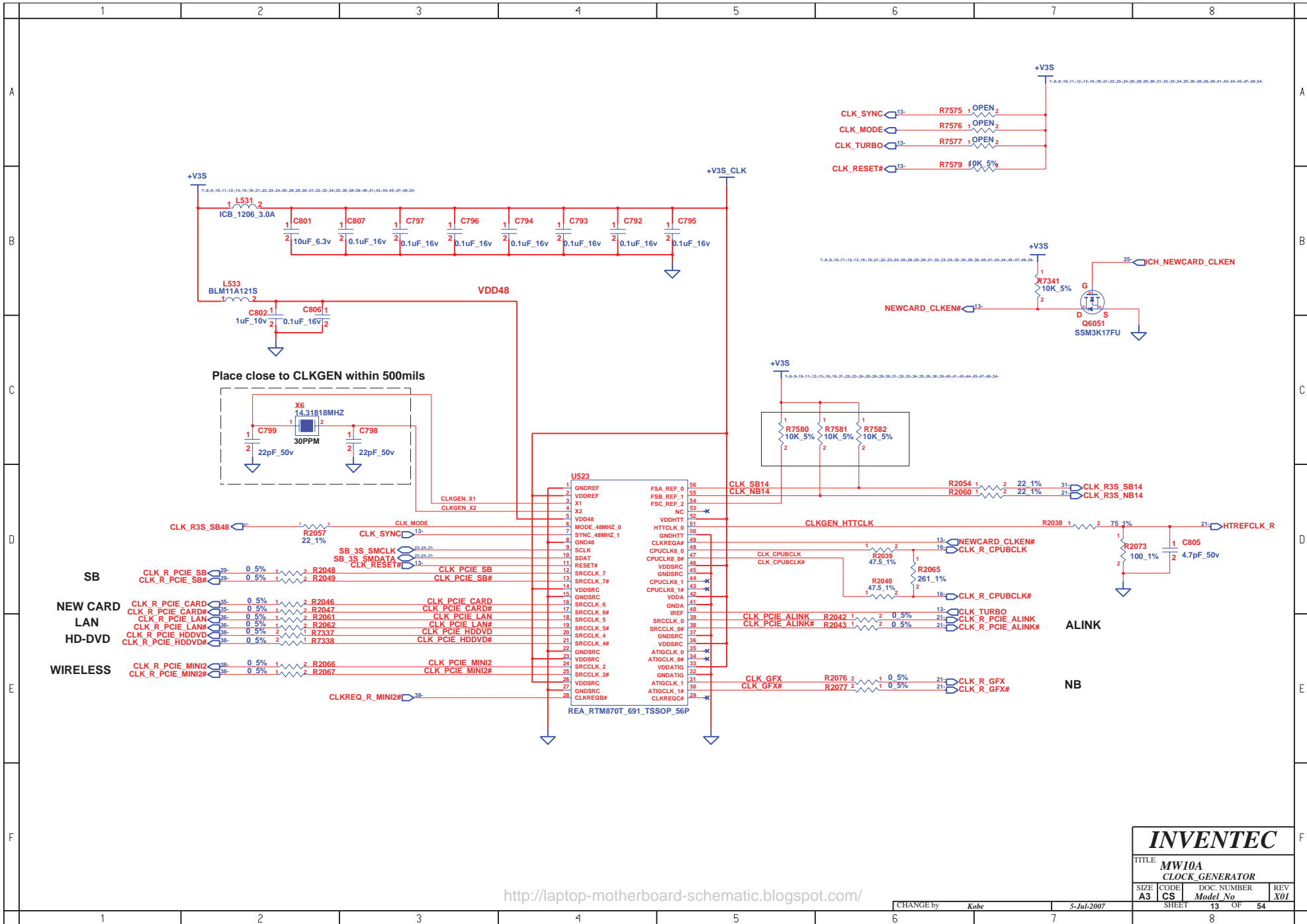

Place close to CLKGEN within 500mils

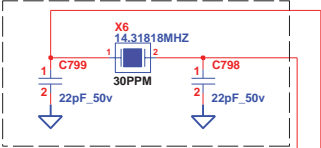

- SB
 - CLK_R_PCIE_SB 29: 0 5% 1 2 R2048
 - CLK_R_PCIE_SBR 29: 0 5% 1 2 R2049
- NEW CARD
 - CLK_R_PCIE_CARD 35: 0 5% 1 2 R2046
 - CLK_R_PCIE_CARD# 35: 0 5% 1 2 R2047
 - CLK_R_PCIE_LAN 36: 0 5% 1 2 R2061
 - CLK_R_PCIE_LAN# 36: 0 5% 1 2 R2062
 - CLK_R_PCIE_HDDVD 38: 0 5% 2 1 R2337
 - CLK_R_PCIE_HDDVD# 38: 0 5% 2 1 R2338
- LAN
 - CLK_R_PCIE_MINI2 38: 0 5% 1 2 R2066
 - CLK_R_PCIE_MINI2# 38: 0 5% 1 2 R2067
- HD-DVD
 - CLK_R_PCIE_MINI2# 38: 0 5% 1 2 R2066
 - CLK_R_PCIE_MINI2# 38: 0 5% 1 2 R2067
- WIRELESS
 - CLKREQ_R_MINI2# 38: 0 5% 1 2 R2066
 - CLKREQ_R_MINI2# 38: 0 5% 1 2 R2067

<http://laptop-motherboard-schematic.blogspot.com/>

INVENTEC			
TITLE MW10A CLOCK_GENERATOR			
SIZE A3	CODE CS	DOC. NUMBER Model No	REV X01
CHANGE by <i>Kobe</i>		5-Jul-2007	
SHEET 13		OF 54	

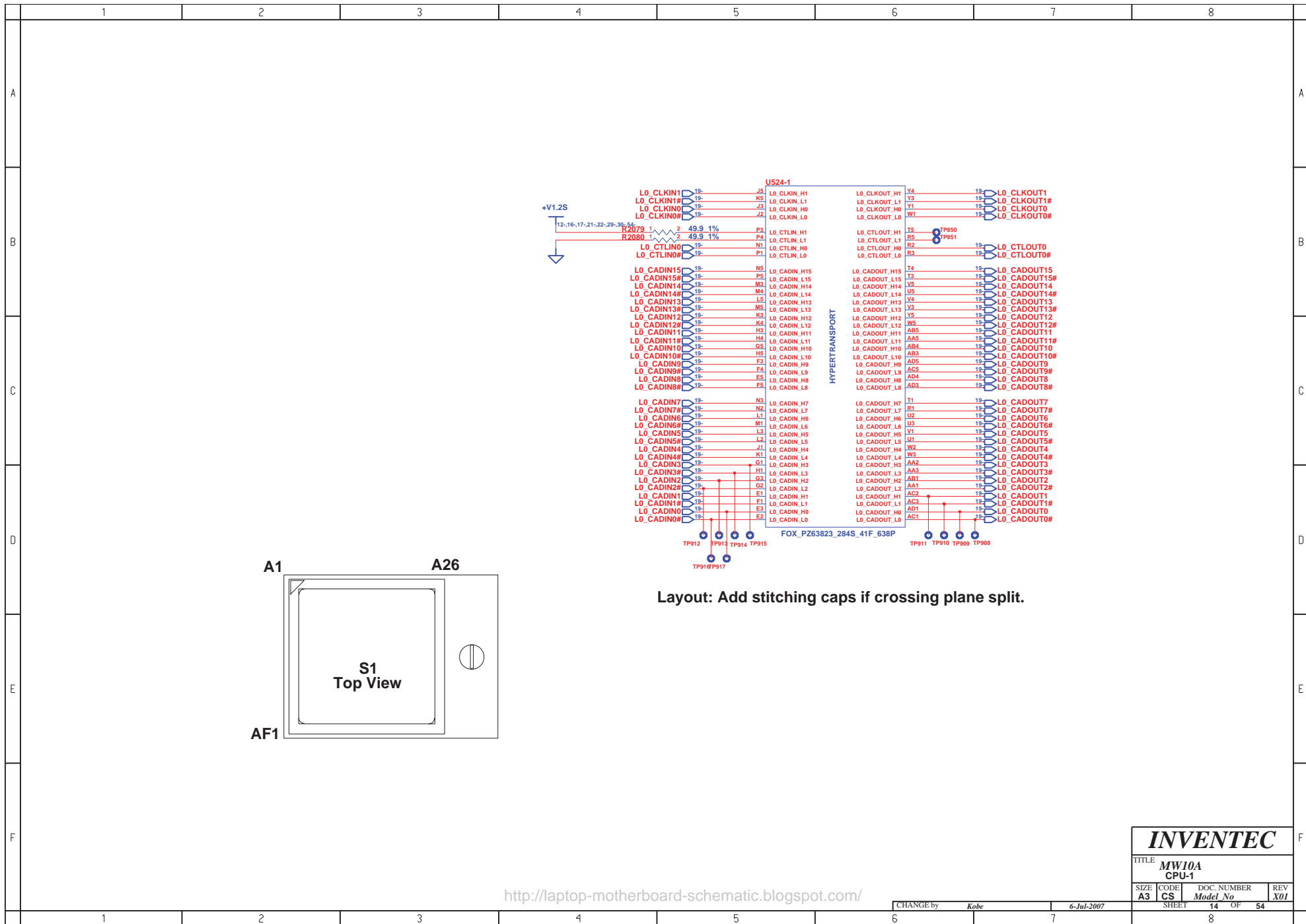

<http://laptop-motherboard-schematic.blogspot.com/>

CHANGE by *Kobe* 6-Jul-2007

INVENTEC			
TITLE MW10A CPU-1			
SIZE A3	CODE CS	DOC. NUMBER Model No	REV X01
SHEET 14		OF 54	

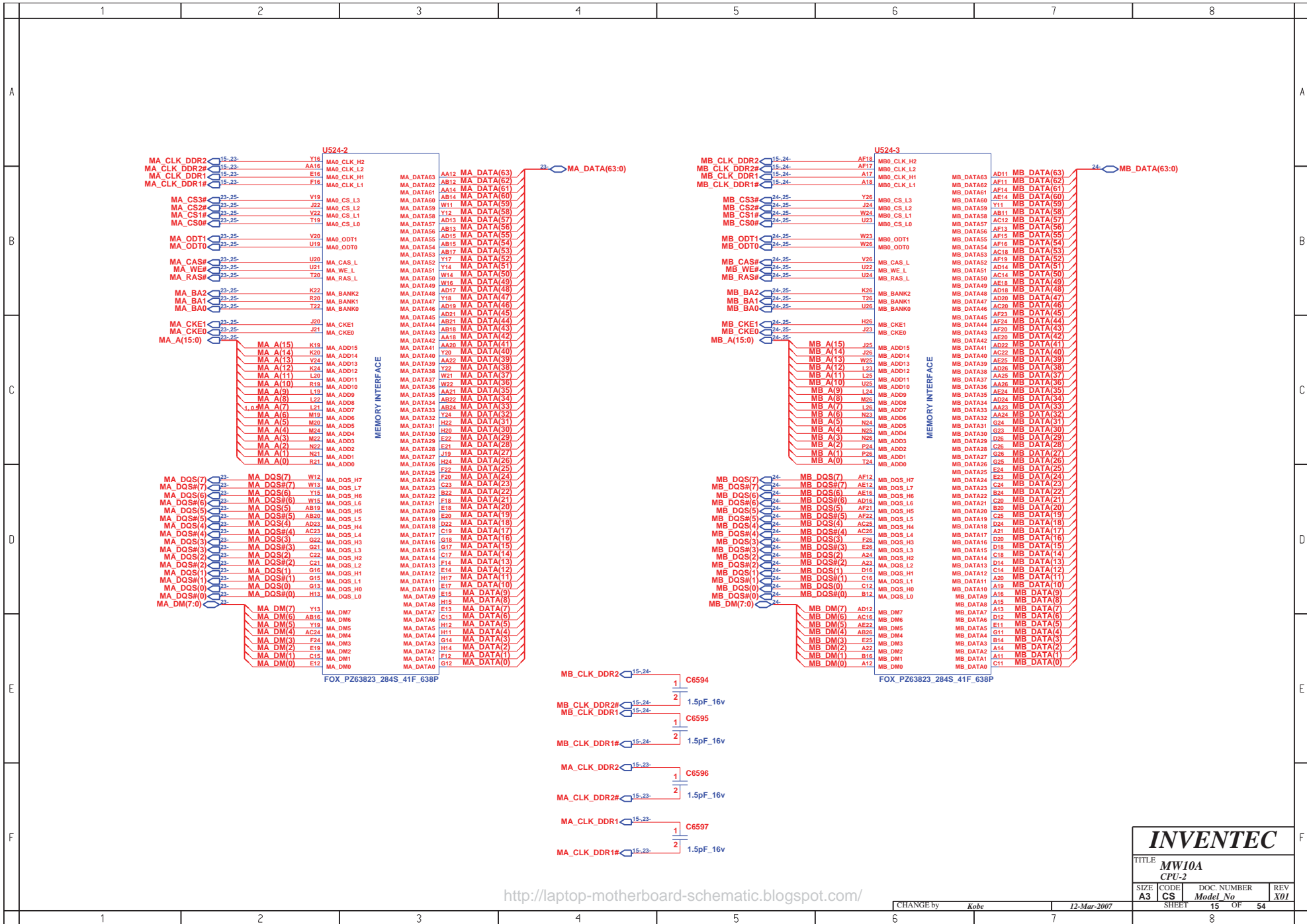

<http://laptop-motherboard-schematic.blogspot.com/>

INVENTEC			
TITLE MW10A CPU-2			
SIZE A3	CODE CS	DOC. NUMBER Model No	REV X01
CHANGE by <i>Kobe</i>		12-Mar-2007	
SHEET 15		OF 54	

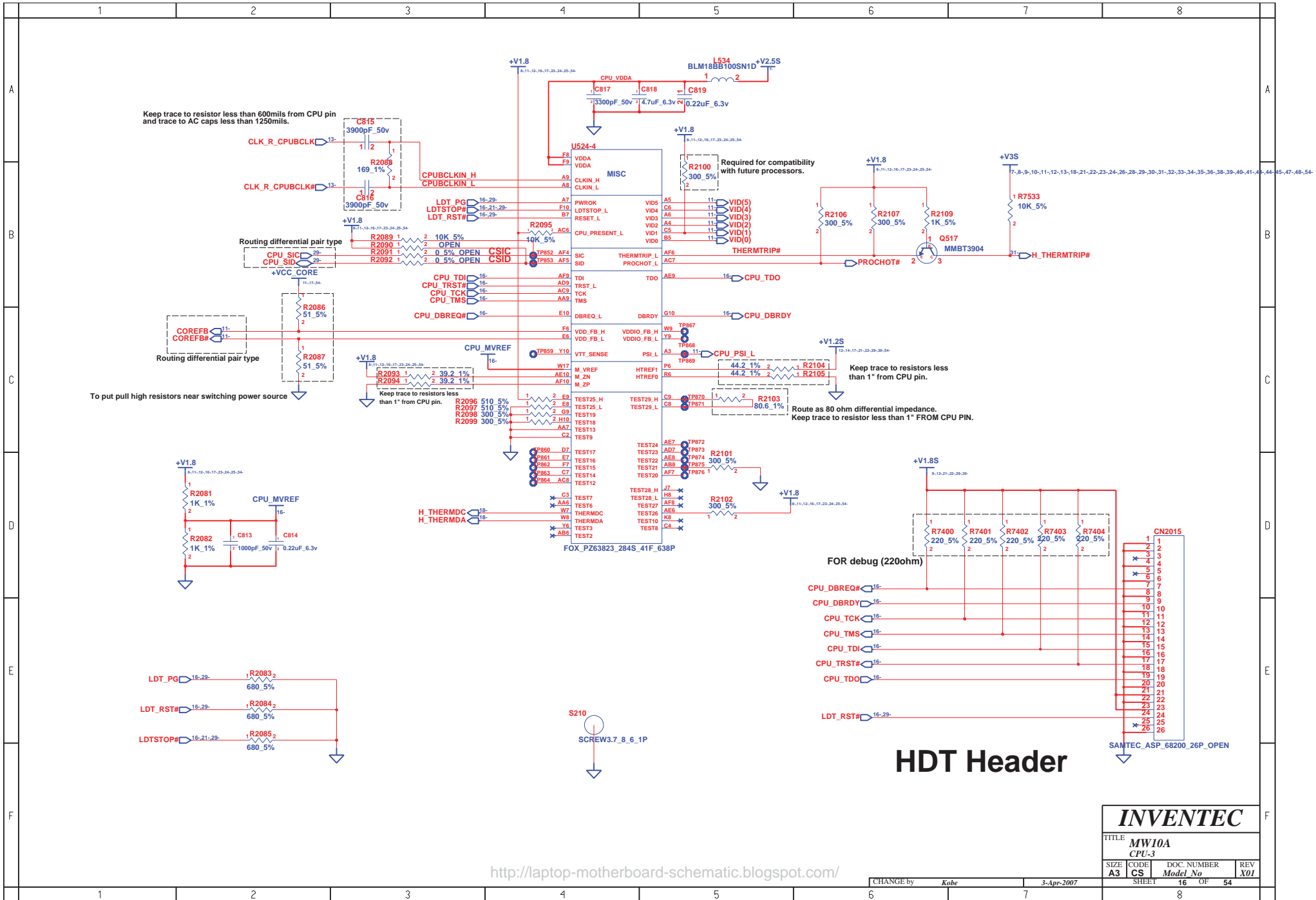

<http://laptop-motherboard-schematic.blogspot.com/>

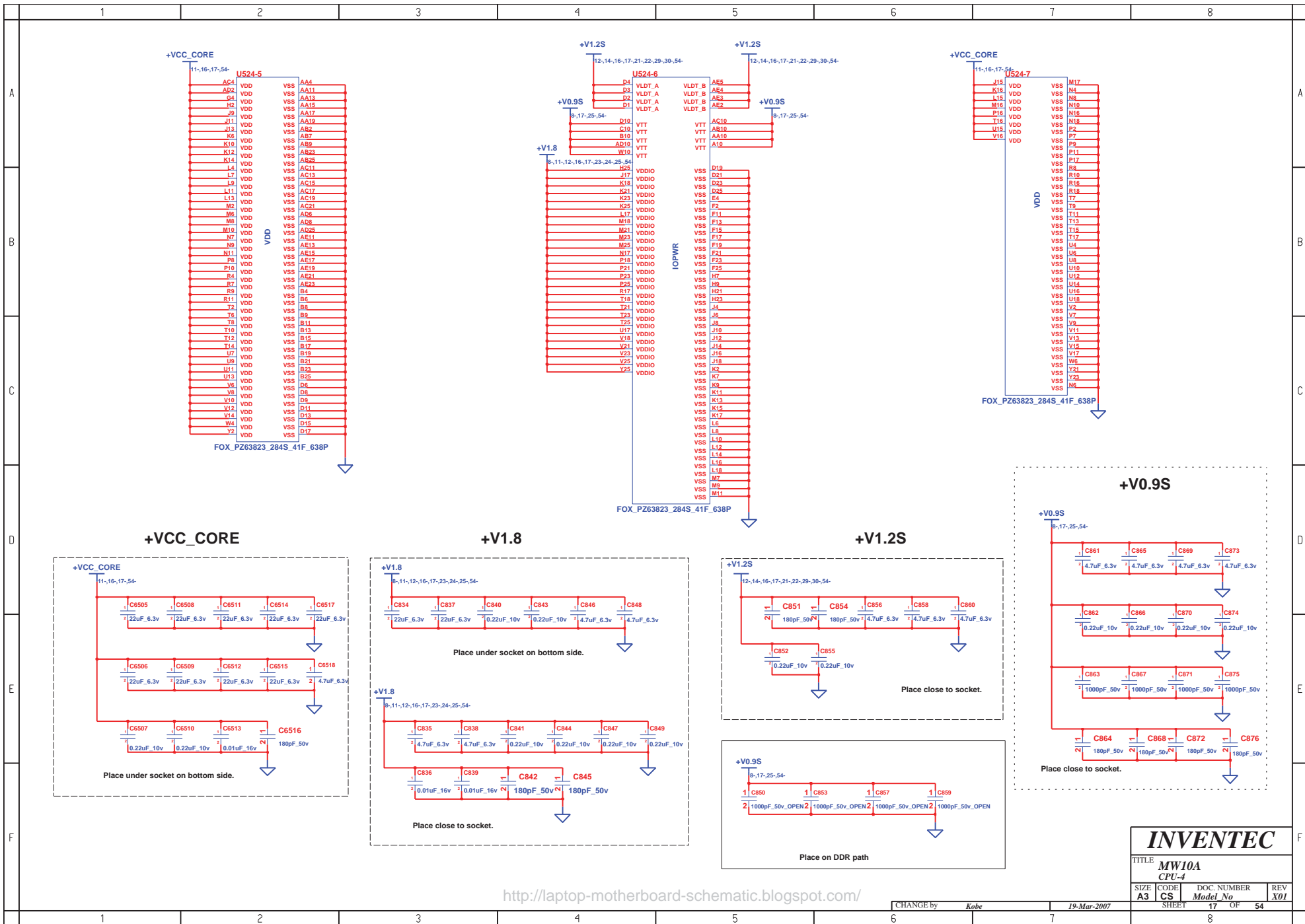

<http://laptop-motherboard-schematic.blogspot.com/>

INVENTEC			
TITLE MW10A CPU-4			
SIZE A3	CODE CS	DOC. NUMBER Model No	REV X01
CHANGE by Kobe		19-Mar-2007	
SHEET 17		OF 54	

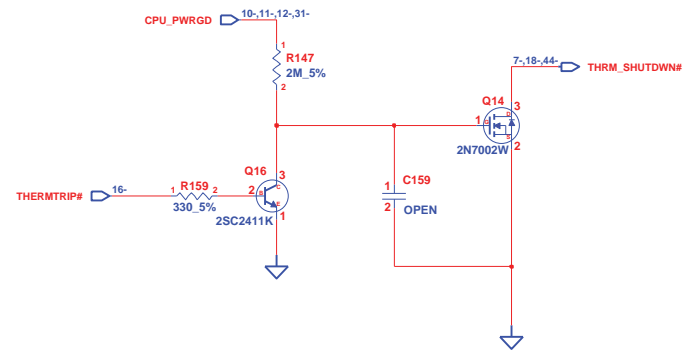
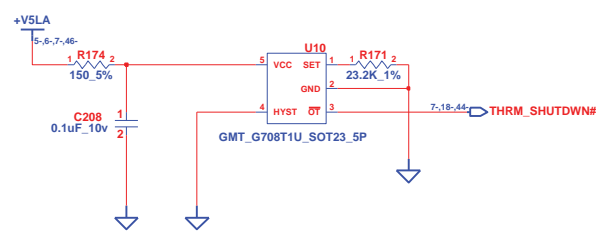
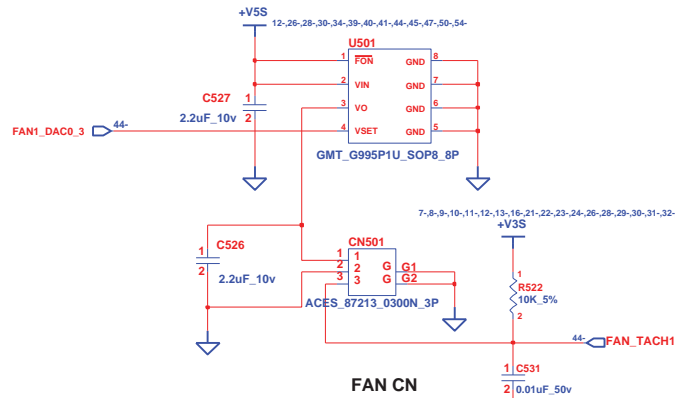

Thermal shoutdown at 86C +/-3C from 60C to 100C

Hysteresis is 30C

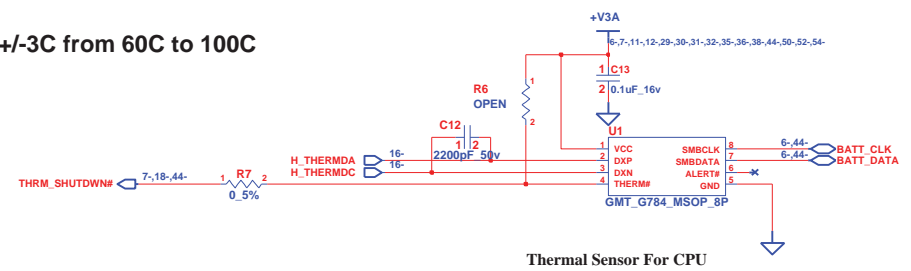

INVENTEC			
TITLE MW10A THERMAL&FAN CONTROLLER			
SIZE A3	CODE CS	DOC. NUMBER <i>Model No</i>	REV X01

<http://laptop-motherboard-schematic.blogspot.com/>

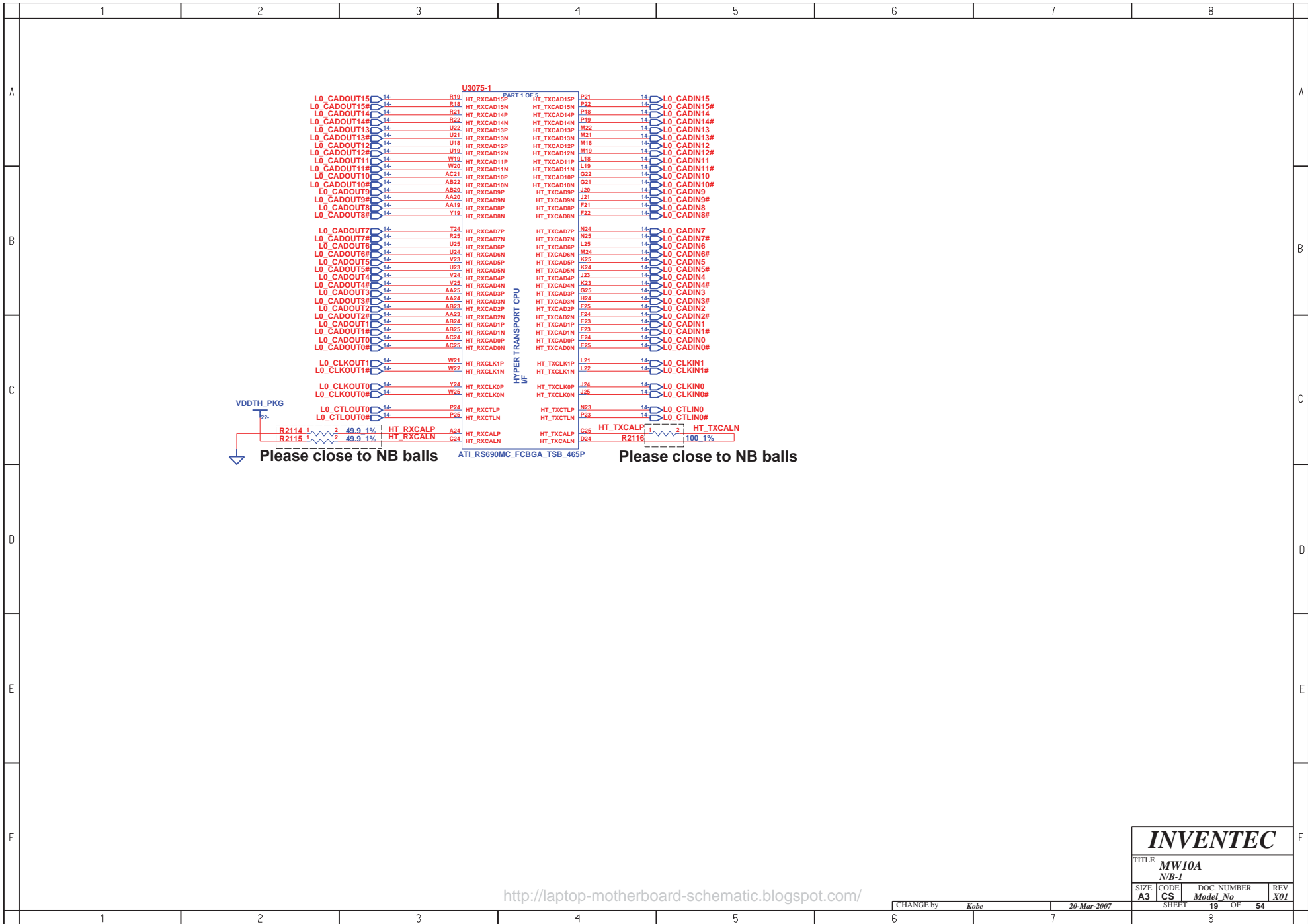

Please close to NB balls

Please close to NB balls

<http://laptop-motherboard-schematic.blogspot.com/>

INVENTEC				
TITLE MW10A N/B-1				
SIZE A3	CODE CS	DOC. NUMBER <i>Model No</i>	REV X01	
CHANGE by <i>Kobe</i> 20-Mar-2007			SHEET 19	OF 54

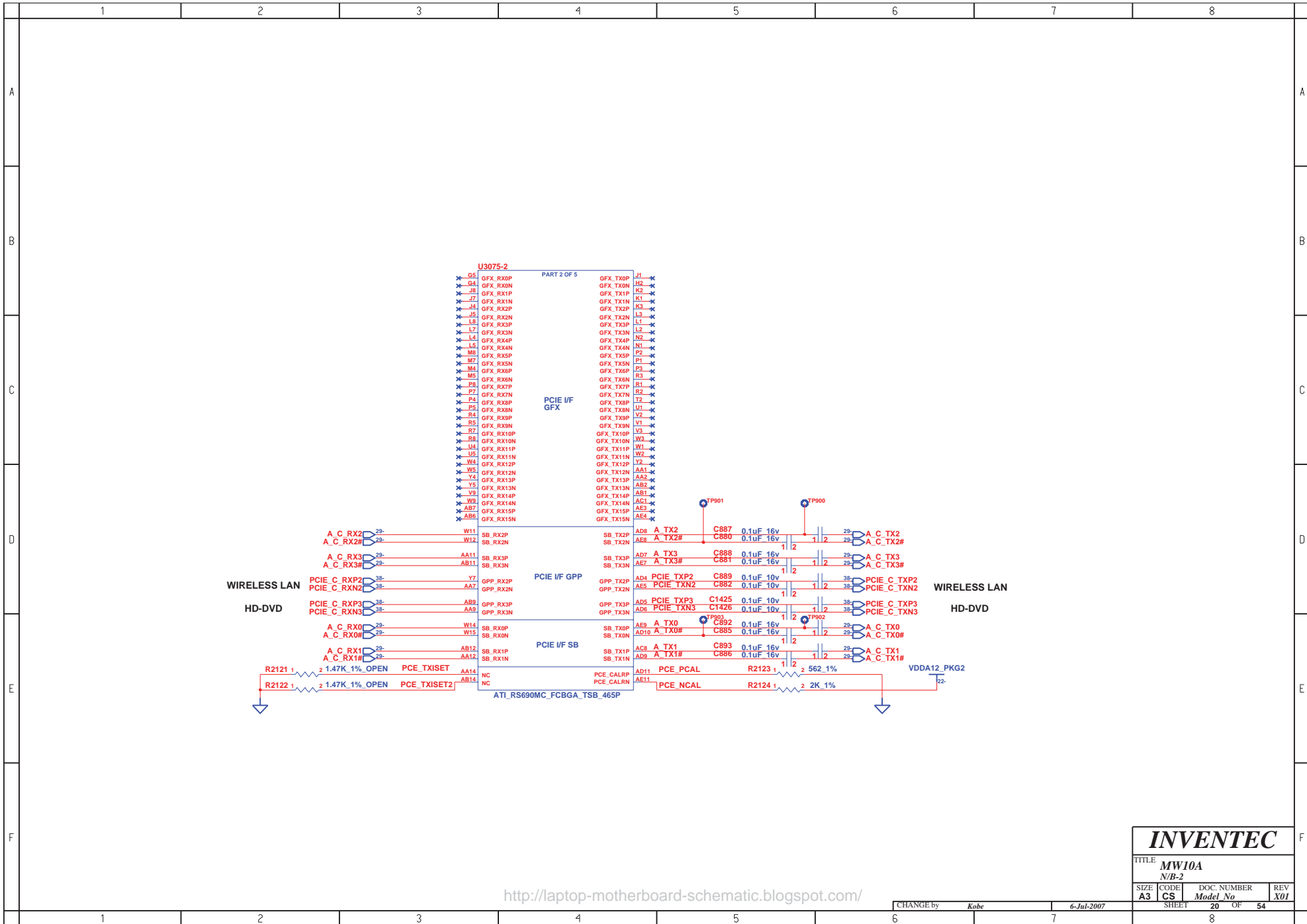

<http://laptop-motherboard-schematic.blogspot.com/>

INVENTEC			
TITLE MW10A N/B-2			
SIZE A3	CODE CS	DOC. NUMBER Model No	REV X01
CHANGE by Kobe		6-Jul-2007	SHEET 20 OF 54

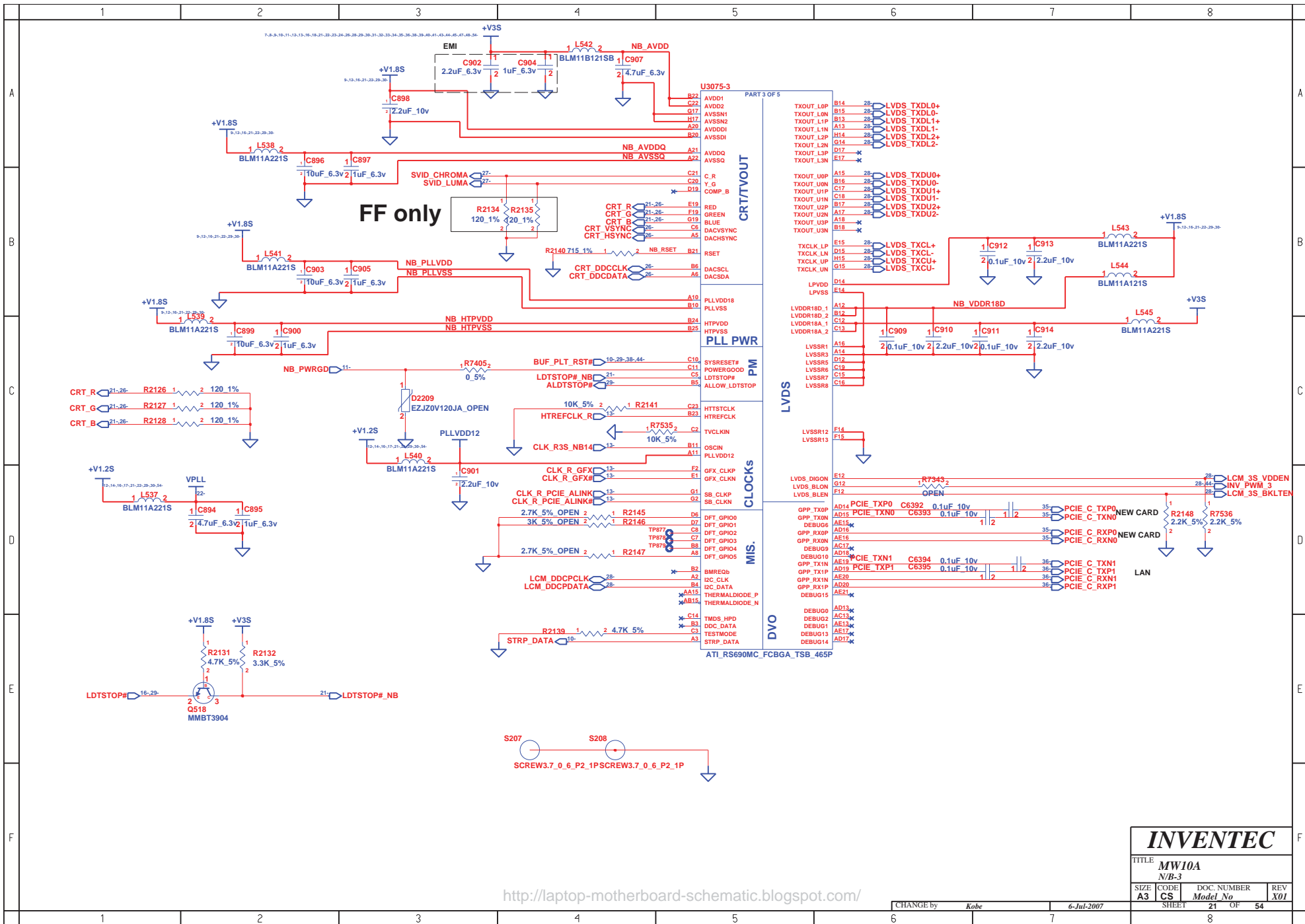

FF only

INVENTEC

TITLE			
MW10A			
N/B-3			
SIZE	CODE	DOC. NUMBER	REV
A3	CS	Model No	X01
CHANGE by		6-Jul-2007	
Kobe		SHEET 21 OF 54	

<http://laptop-motherboard-schematic.blogspot.com/>

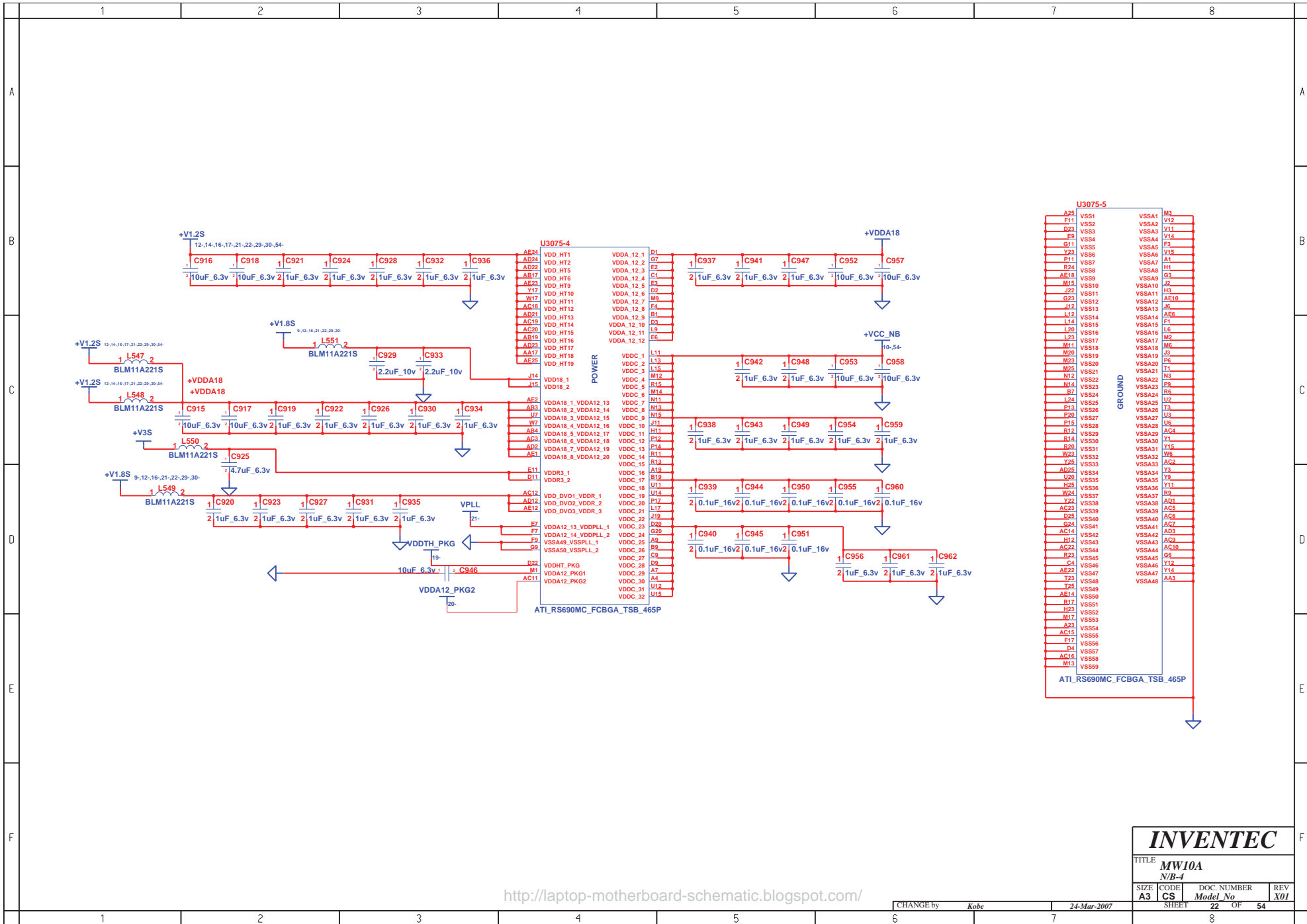

<http://laptop-motherboard-schematic.blogspot.com/>

INVENTEC

TITLE			
MW10A			
N/B-4			
SIZE	CODE	DOC. NUMBER	REV
A3	CS	Model No	X01
CHANGE by			SHEET
Kobe			22 OF 54
24-Mar-2007			8

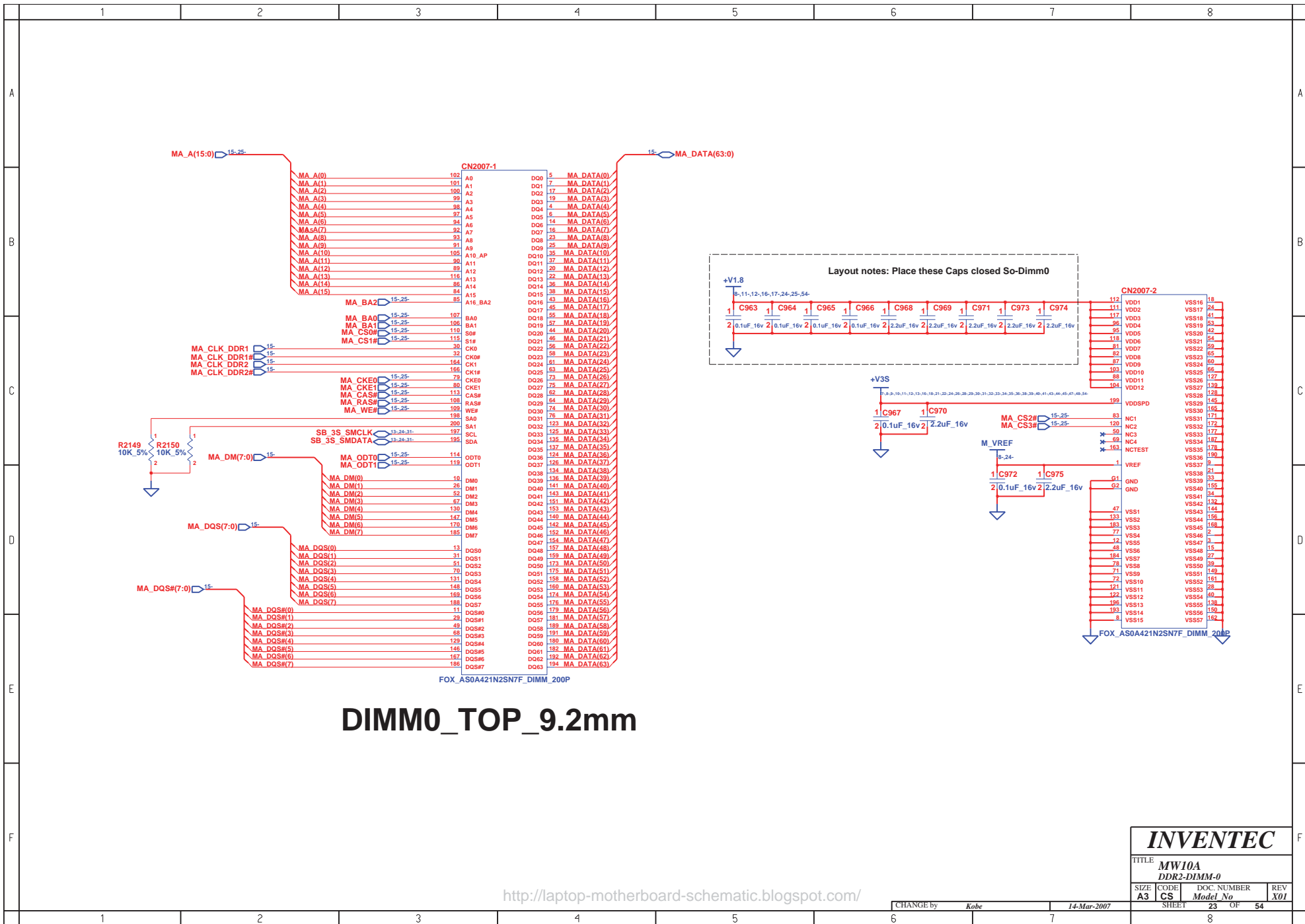

DIMM0_TOP_9.2mm

<http://laptop-motherboard-schematic.blogspot.com/>

INVENTEC

TITLE			
MW10A			
DDR2-DIMM-0			
SIZE	CODE	DOC. NUMBER	REV
A3	CS	Model No	X01
CHANGE by			SHEET
Kobe			23 OF 54
14-Mar-2007			8

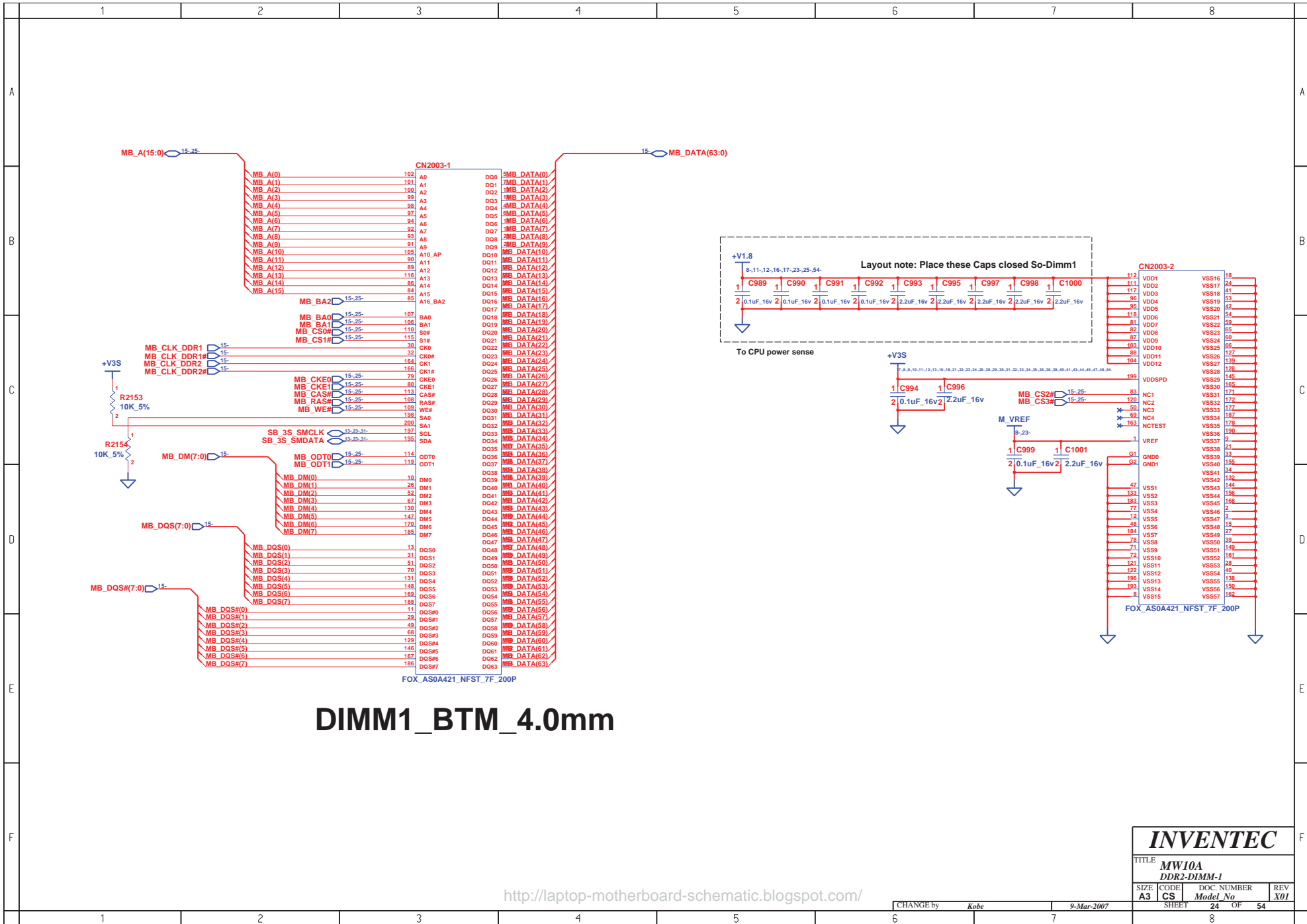

DIMM1_BTM_4.0mm

<http://laptop-motherboard-schematic.blogspot.com/>

INVENTEC			
TITLE MW10A DDR2-DIMM-1			
SIZE A3	CODE CS	DOC. NUMBER Model No	REV X01
CHANGE by Kobe		9-Mar-2007	
SHEET 24		OF 54	

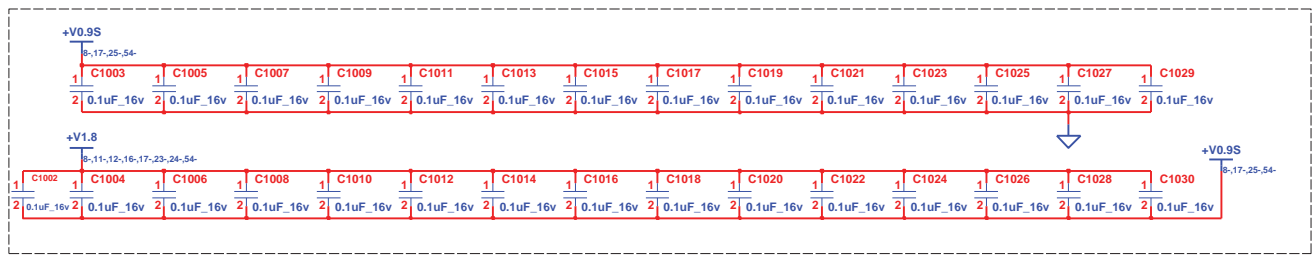

To CPU power sense

Place CAPs close to DIMM

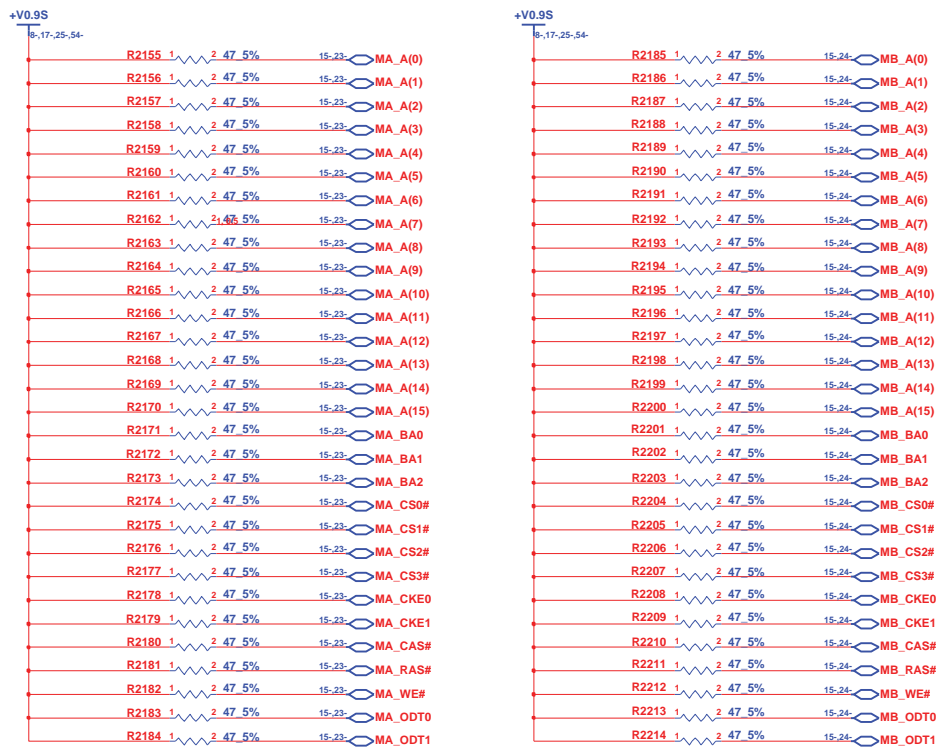

<http://laptop-motherboard-schematic.blogspot.com/>

INVENTEC			
TITLE			
MW10A DDR2-DAMPING			
SIZE	CODE	DOC. NUMBER	REV
A3	CS	Model No	X01
CHANGE by		9-Mar-2007	
Kobe		SHEET 25 OF 54	

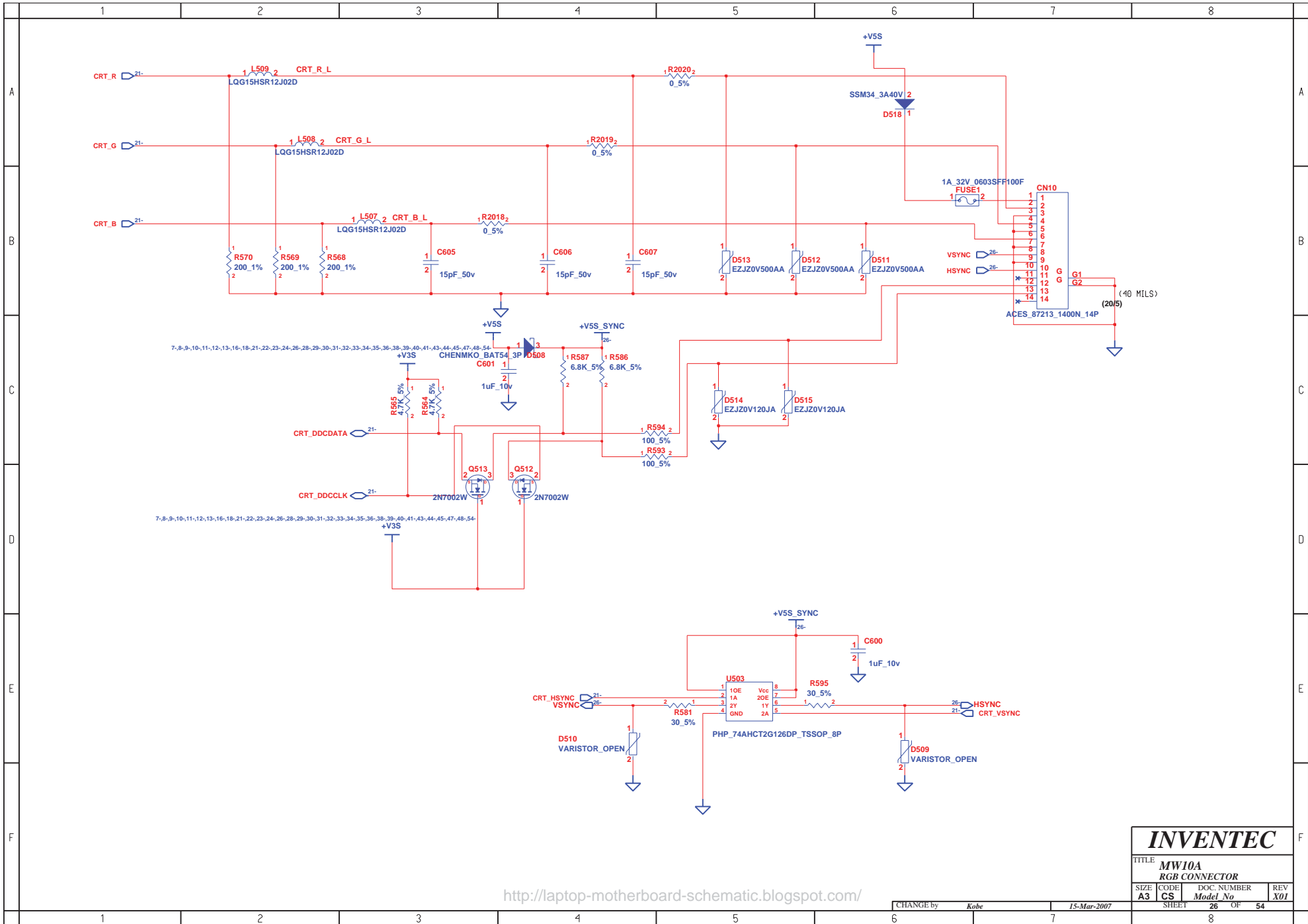

INVENTEC			
TITLE MW10A RGB CONNECTOR			
SIZE A3	CODE CS	DOC. NUMBER Model No	REV X01
CHANGE by <i>Kobe</i>		15-Mar-2007	SHEET 26 OF 54

<http://laptop-motherboard-schematic.blogspot.com/>

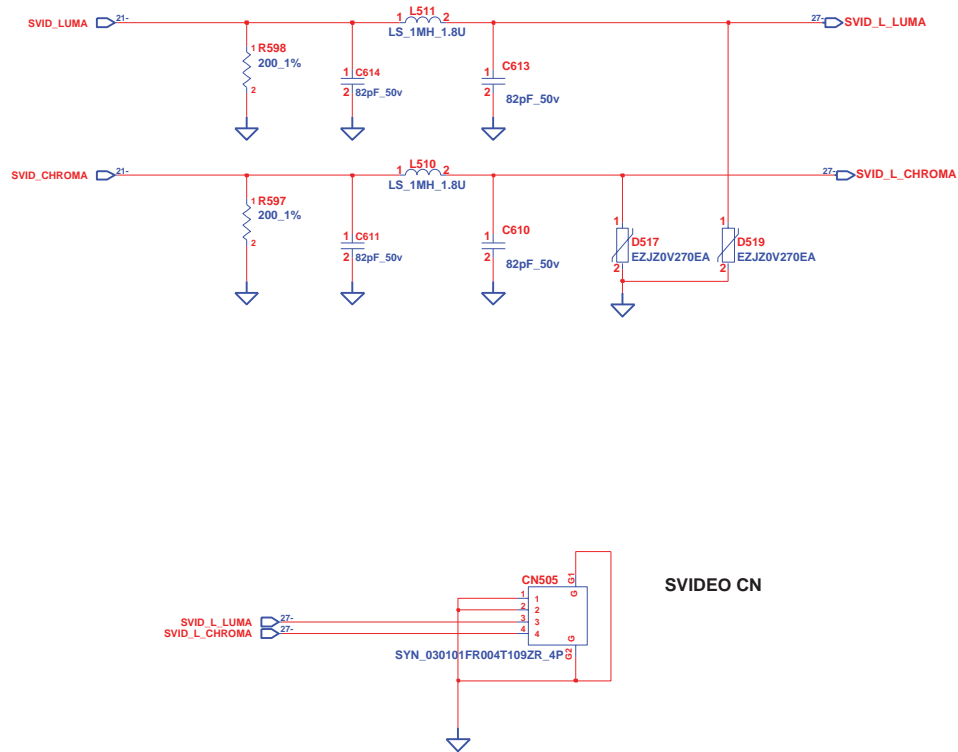

<http://laptop-motherboard-schematic.blogspot.com/>

INVENTEC			
TITLE MW10A S-Video CONN			
SIZE A3	CODE CS	DOC. NUMBER Model No	REV X01
CHANGE by <i>Kobe</i>		8-Mar-2007	SHEET 27 OF 54

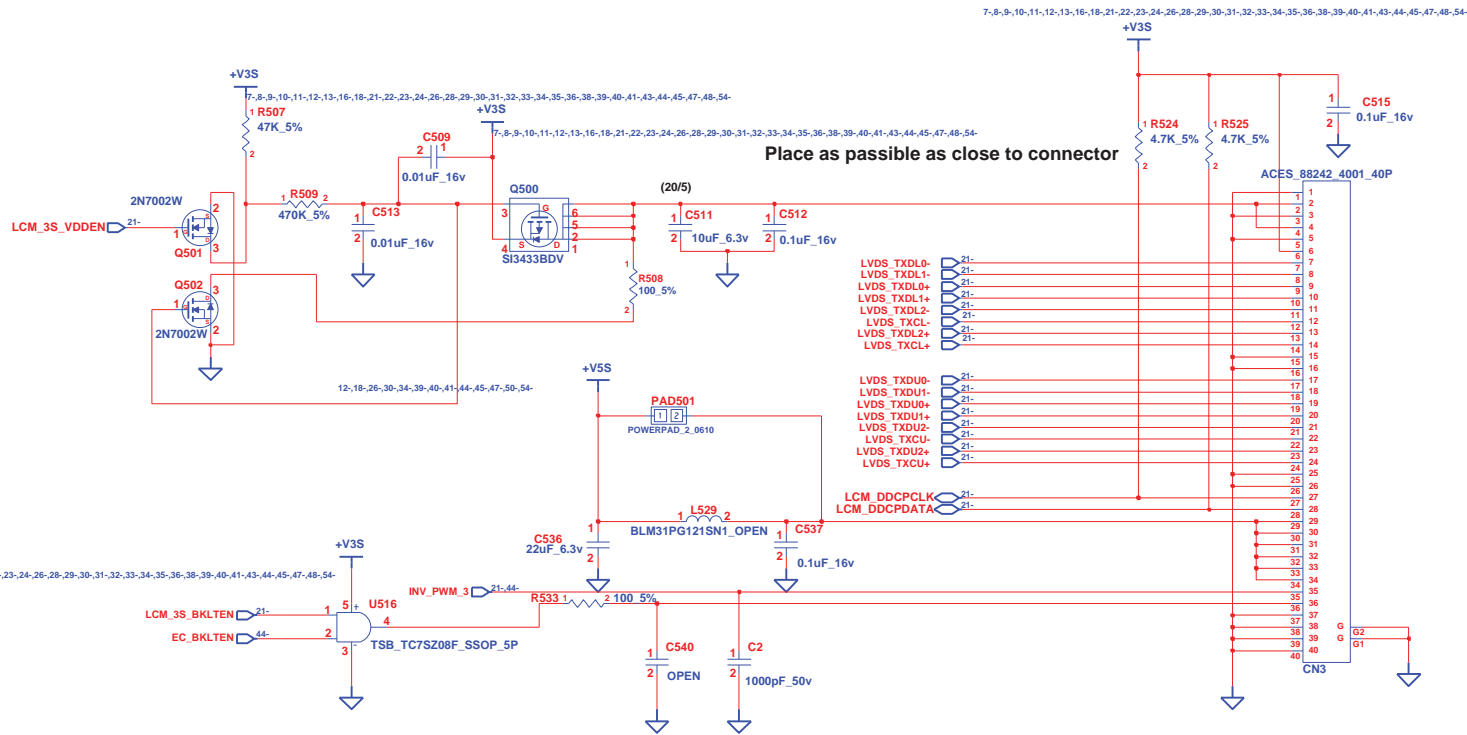

<http://laptop-motherboard-schematic.blogspot.com/>

INVENTEC

TITLE			
MW10A			
LCM			
SIZE	CODE	DOC. NUMBER	REV
A3	CS	Model No	X01

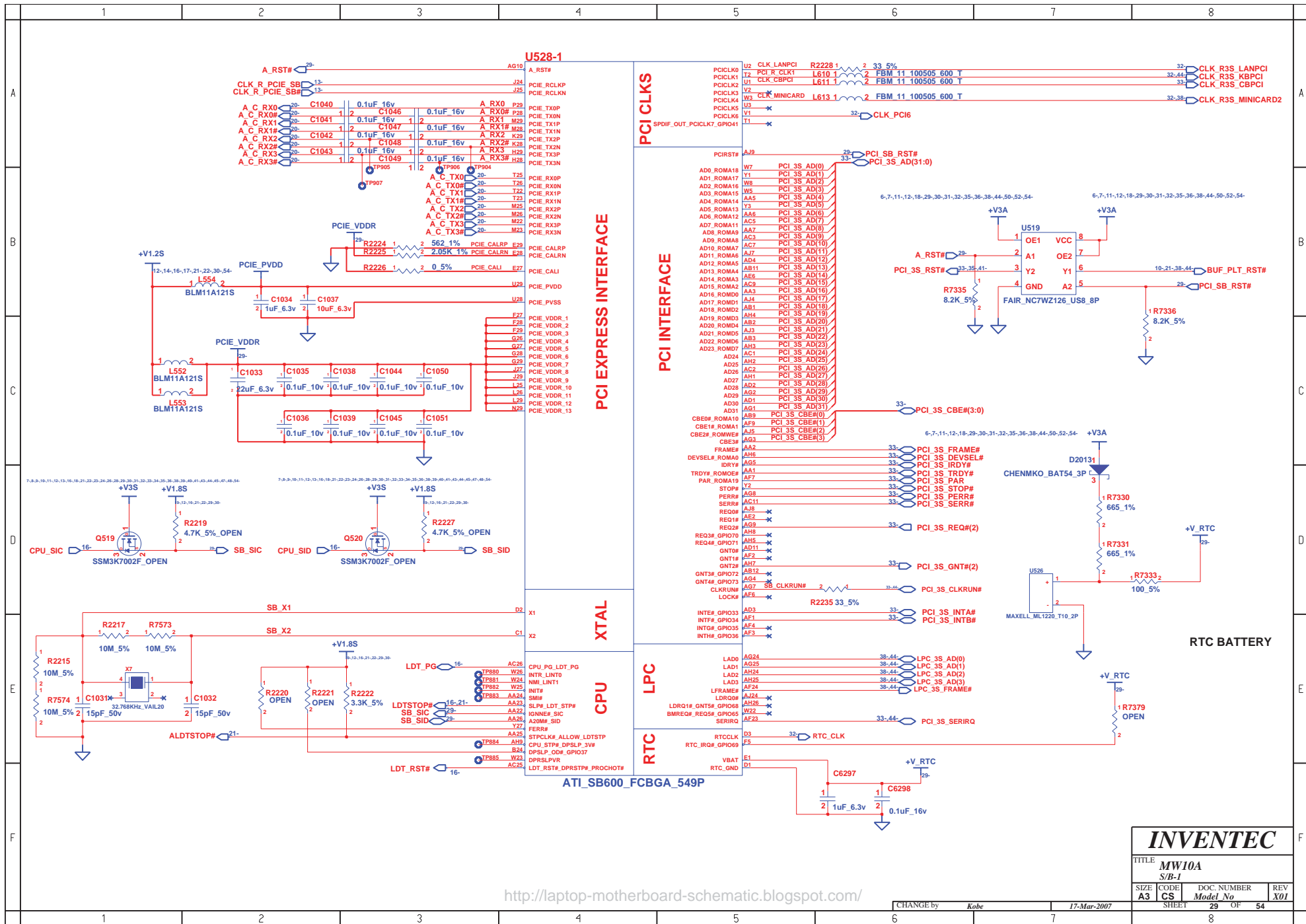

INVENTEC			
TITLE MW10A			
S/B-1			
SIZE A3	CODE CS	DOC. NUMBER <i>Model No</i>	REV X01
CHANGE by <i>Kobe</i>		17-Mar-2007	
SHEET 29		OF 54	

<http://laptop-motherboard-schematic.blogspot.com/>

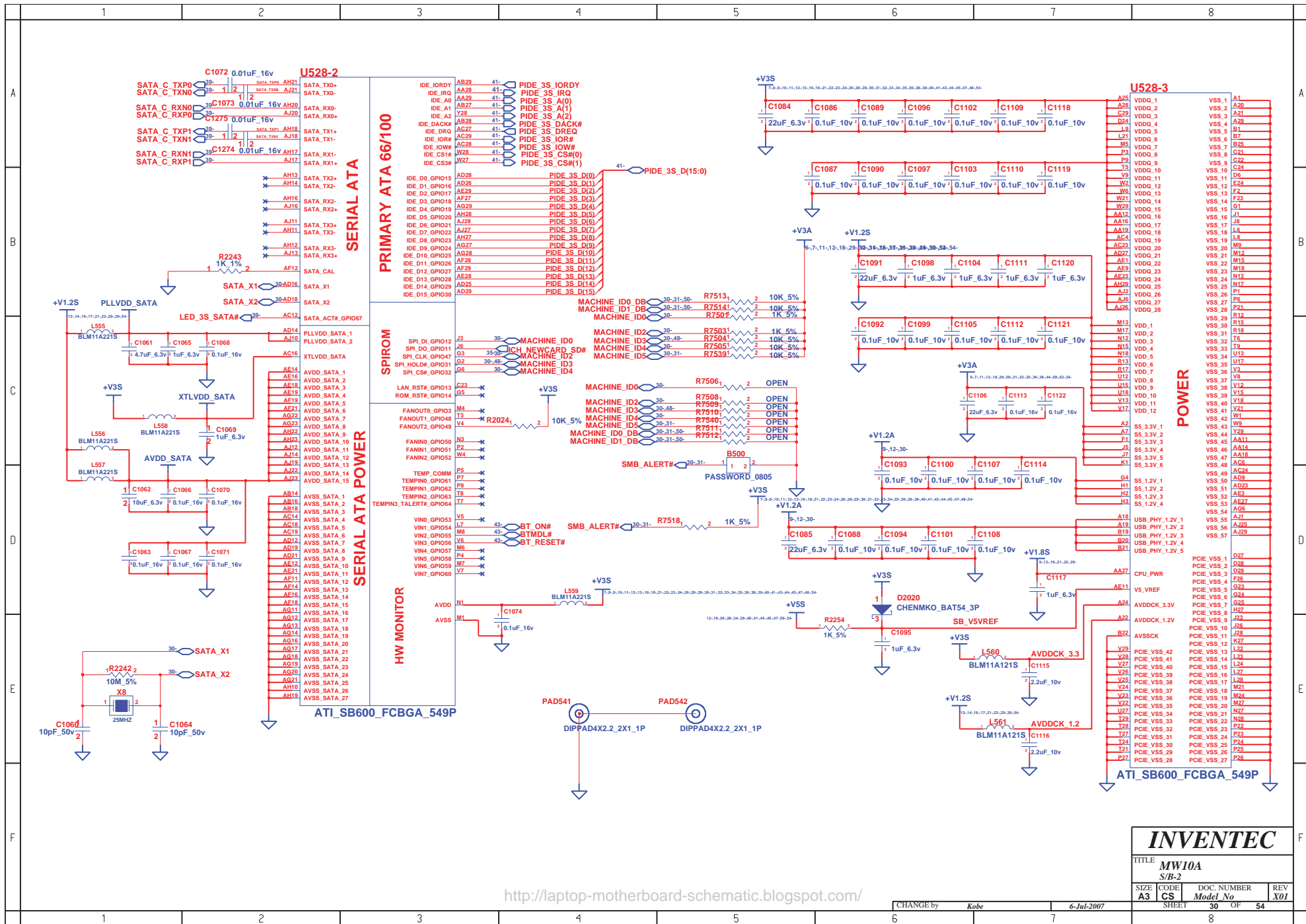

INVENTEC

TITLE			
MW10A			
S/B-2			
SIZE	CODE	DOC. NUMBER	REV
A3	CS	Model No	X01
CHANGE by		6-Jul-2007	
Kobe		6-Jul-2007	
SHEET		30 OF 54	

<http://laptop-motherboard-schematic.blogspot.com/>

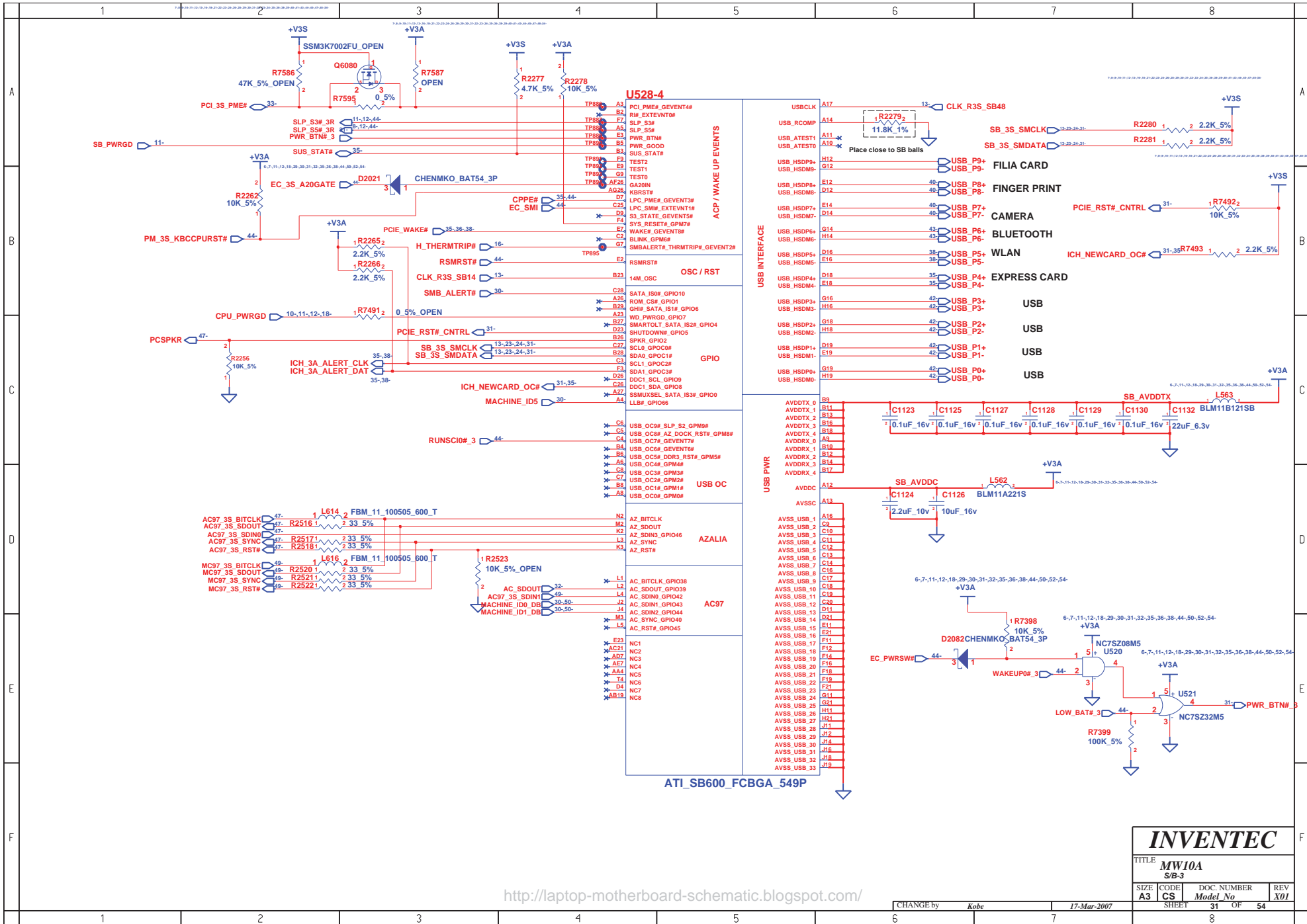

<http://laptop-motherboard-schematic.blogspot.com/>

INVENTEC			
TITLE MW10A S/B-3			
SIZE A3	CODE CS	DOC. NUMBER <i>Model No</i>	REV X01
CHANGE by <i>Kobe</i>		17-Mar-2007	
SHEET 31		OF 54	

Required Straps:

	AC_SDOUT	RTC_CLK	CLK_R3S_MINICARD2	PCI_CLK6	PCI_CLK0 PCI_CLK1
PULL HIGH	USE DEBUG STRAPS	INTERNAL RTC	USE INT. PLL48	CPU K8	HH: PCI ROM HL: SPI ROM
PULL LOW	IGNORE DEBUG STRAPS	EXTERNAL RTC	USE EXT. 48M CLK	CPU P4	LH: LPC ROM LL: FWH ROM

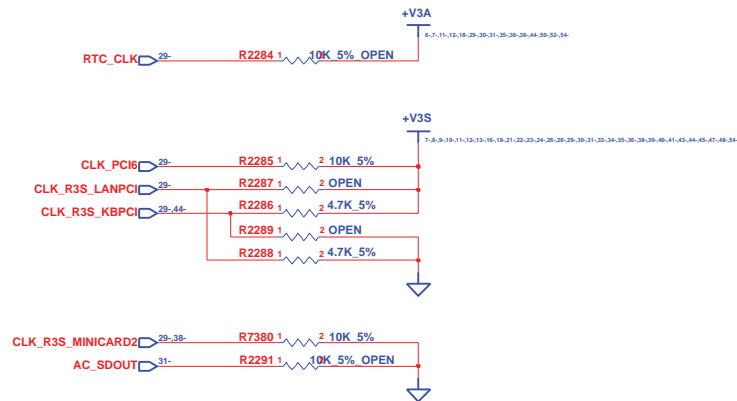

<http://laptop-motherboard-schematic.blogspot.com/>

INVENTEC			
TITLE MW10A			
S/B-4			
SIZE A3	CODE CS	DOC. NUMBER Model No	REV X01
CHANGE by <i>Kobe</i>		5-Jun-2007	
SHEET 32		OF 54	

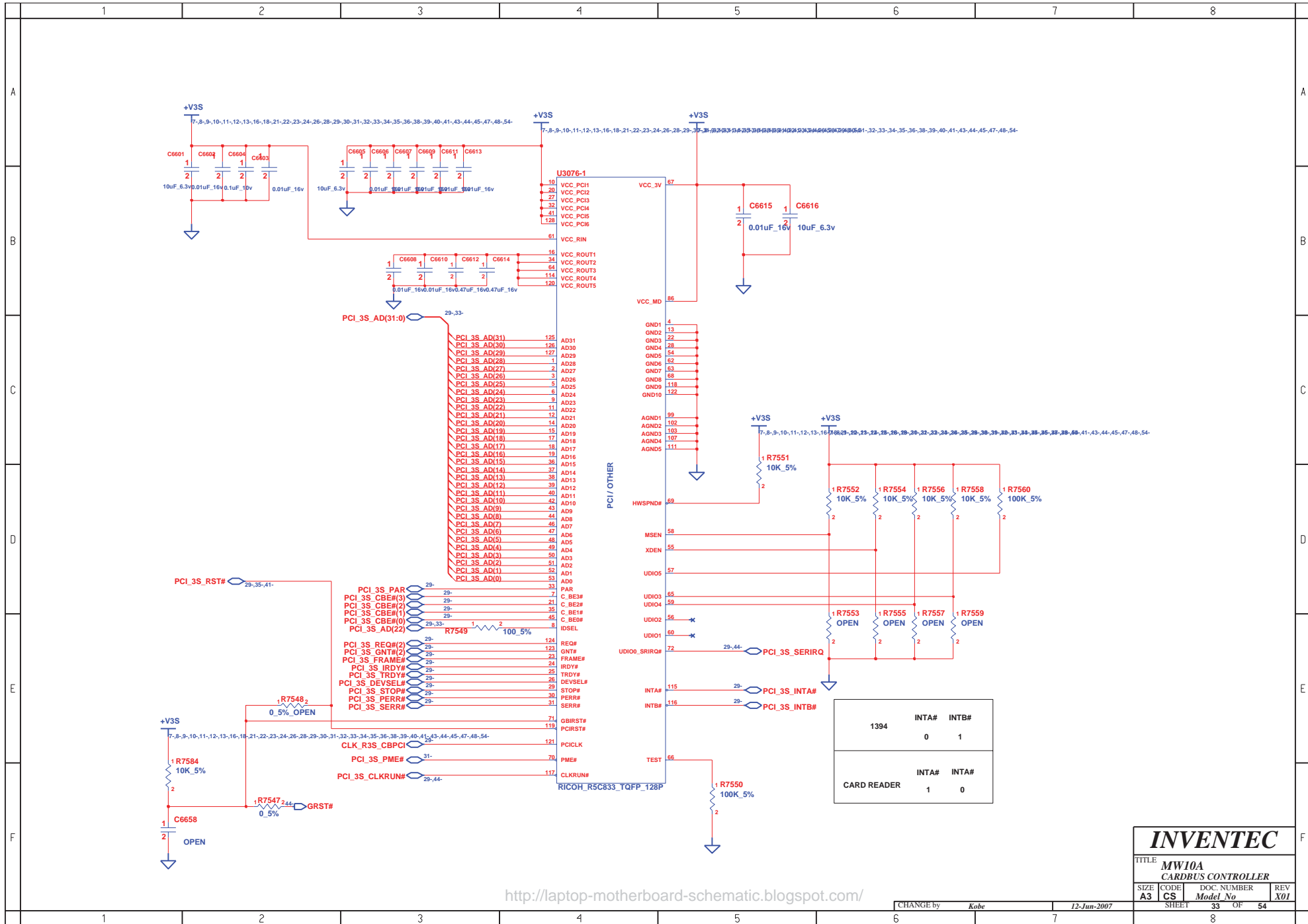

<http://laptop-motherboard-schematic.blogspot.com/>

INVENTEC

TITLE
**MW10A
 CARBUS CONTROLLER**

SIZE A3	CODE CS	DOC. NUMBER Model No	REV X01
------------	------------	-------------------------	------------

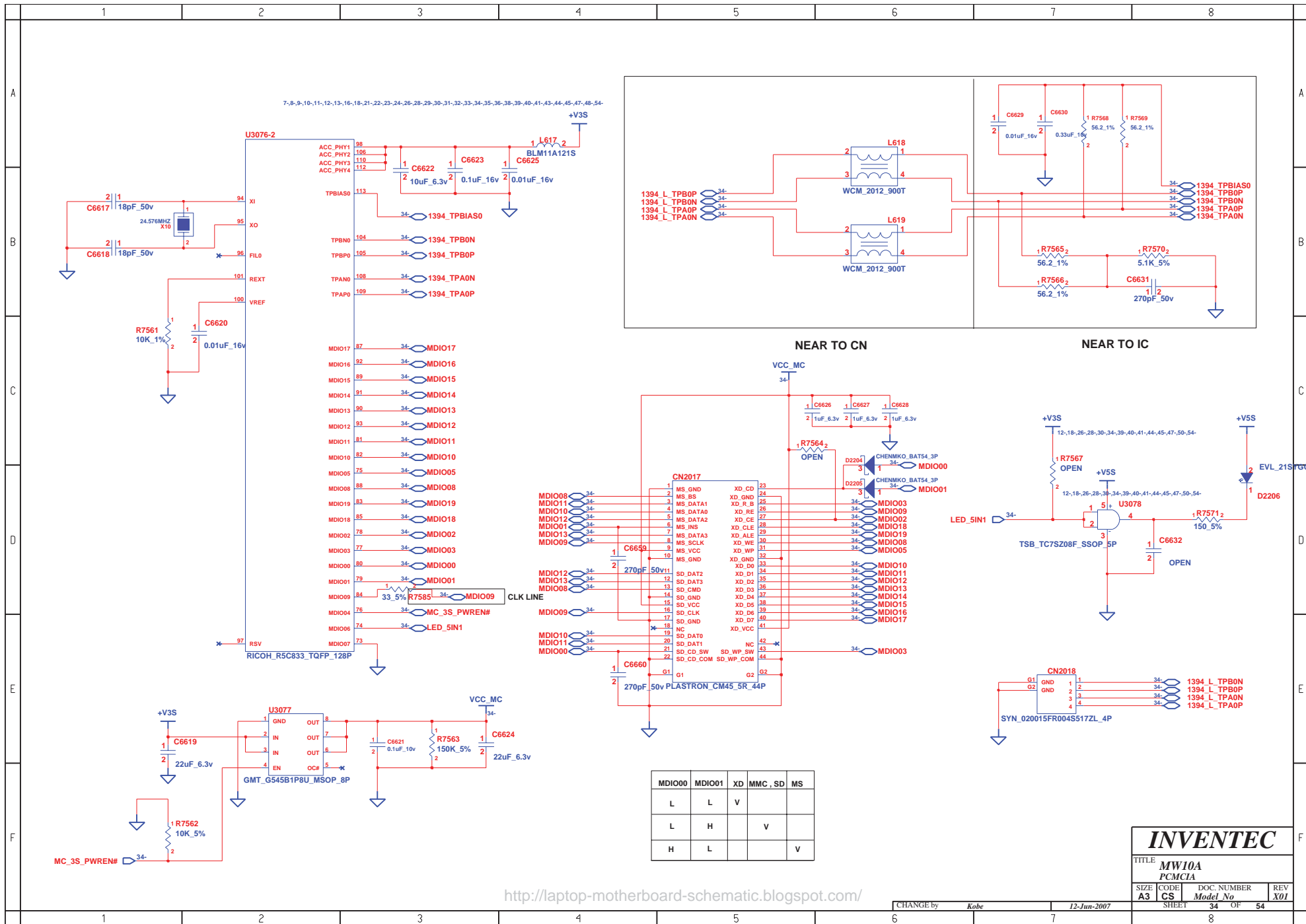

MDIO00	MDIO01	XD	MMC, SD	MS
L	L	V		
L	H	V		
H	L	V		

<http://laptop-motherboard-schematic.blogspot.com/>

INVENTEC

TITLE: MW10A PCMCIA

SIZE	CODE	DOC. NUMBER	REV
A3	CS	Model No	X01

SHEET 34 OF 54

CHANGE by Kobe 12-Jun-2007

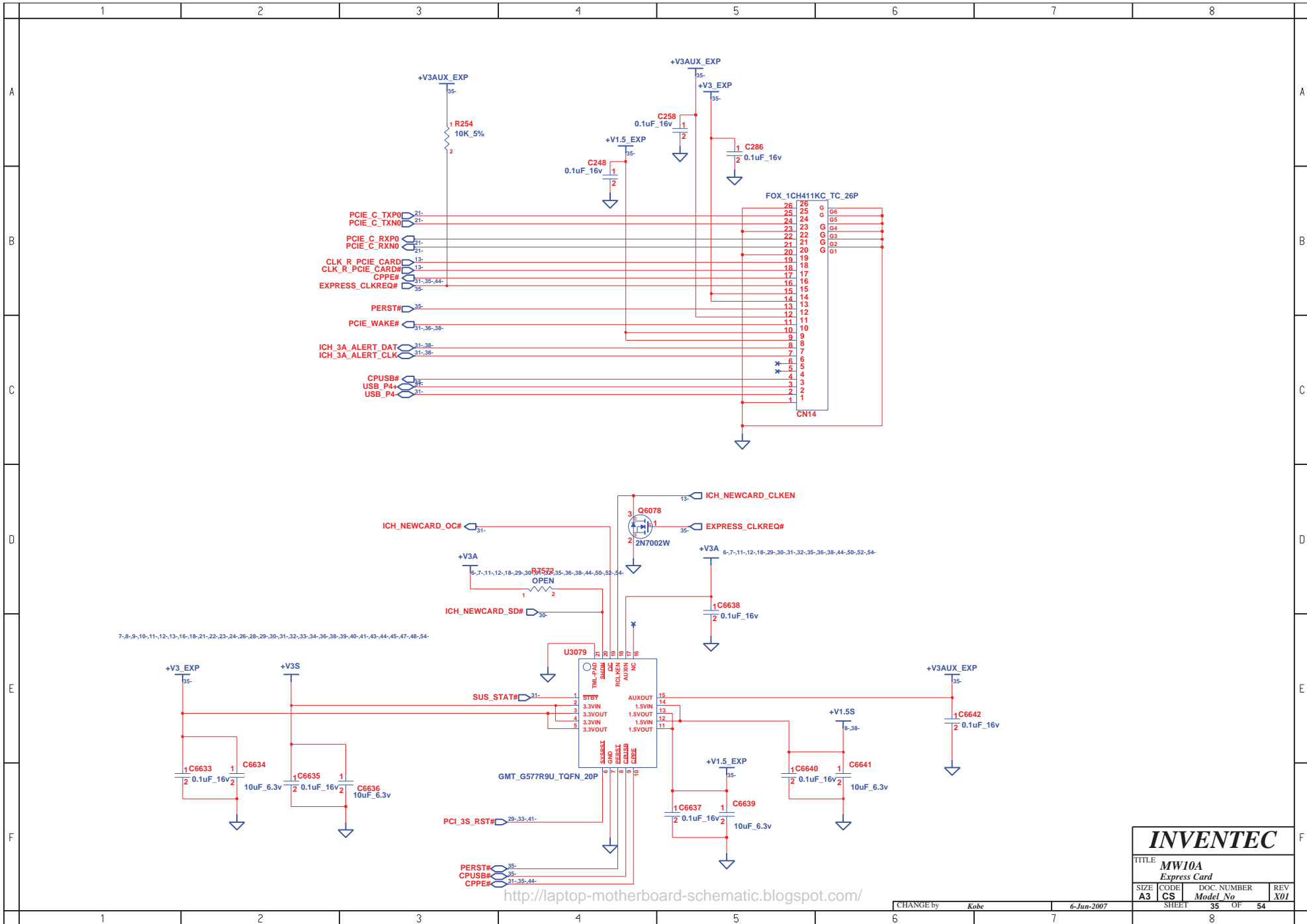

<http://laptop-motherboard-schematic.blogspot.com/>

INVENTEC

TITLE			
MW10A			
Express Card			
SIZE	CODE	DOC. NUMBER	REV
A3	CS	Model No	X01

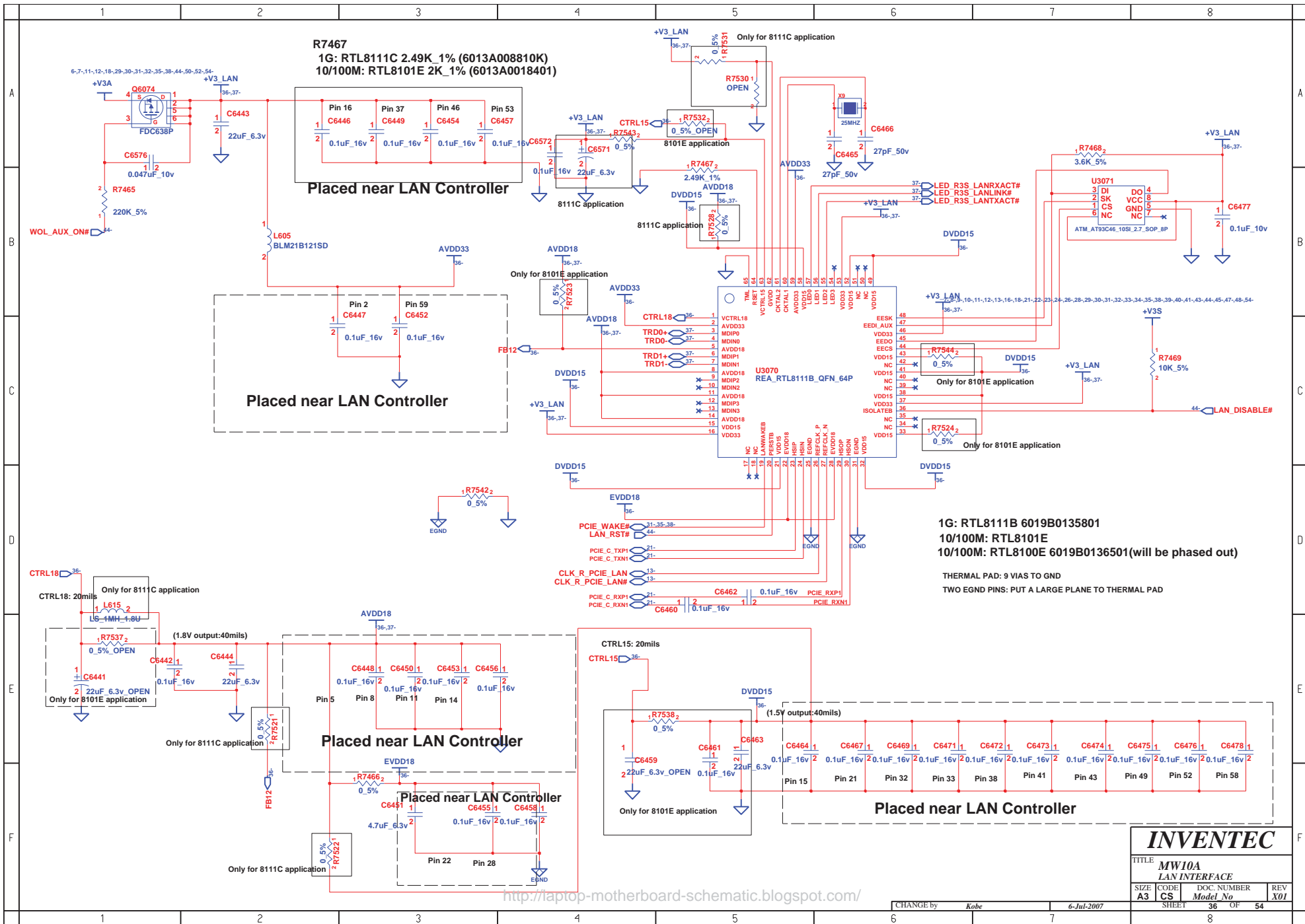

<http://laptop-motherboard-schematic.blogspot.com/>

INVENTEC

TITLE			
MW10A LAN INTERFACE			
SIZE	CODE	DOC NUMBER	REV
A3	CS	Model No	X01
SHEET		OF	
36		54	

CHANGE by Kobe 6-Jul-2007

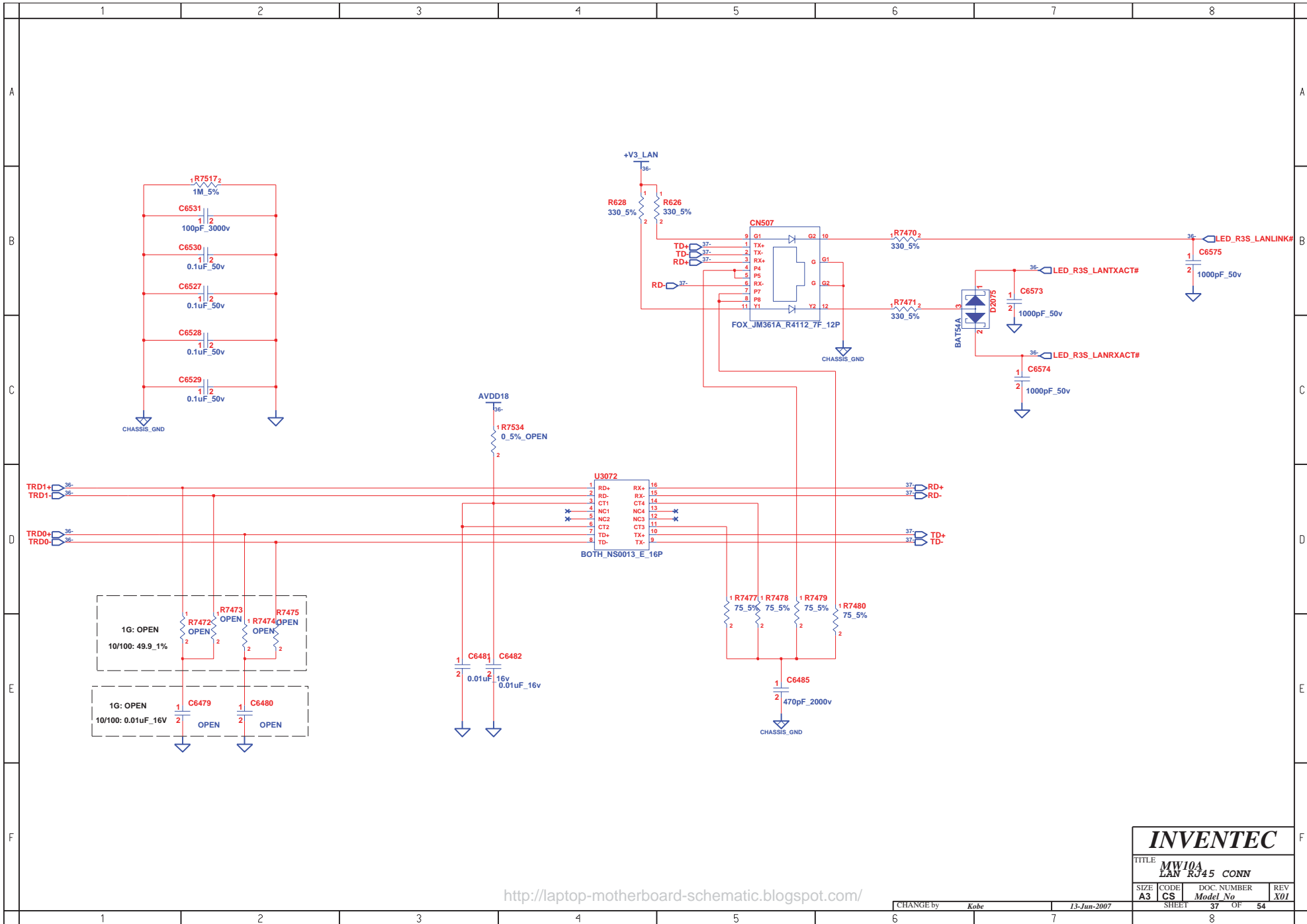

<http://laptop-motherboard-schematic.blogspot.com/>

INVENTEC

TITLE			
MW10A LAN RJ45 CONN			
SIZE	CODE	DOC. NUMBER	REV
A3	CS	Model No	X01

CHANGE by	Kobe	13-Jun-2007	SHEET	37	OF	54
-----------	------	-------------	-------	----	----	----

HD_DVD

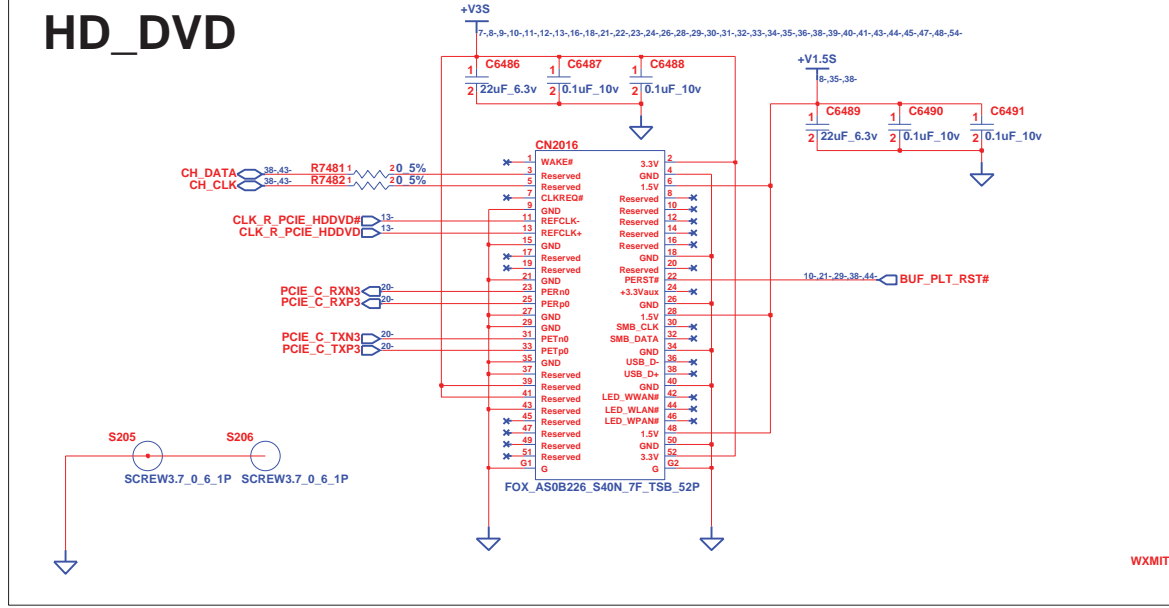

Wireless & Debug card

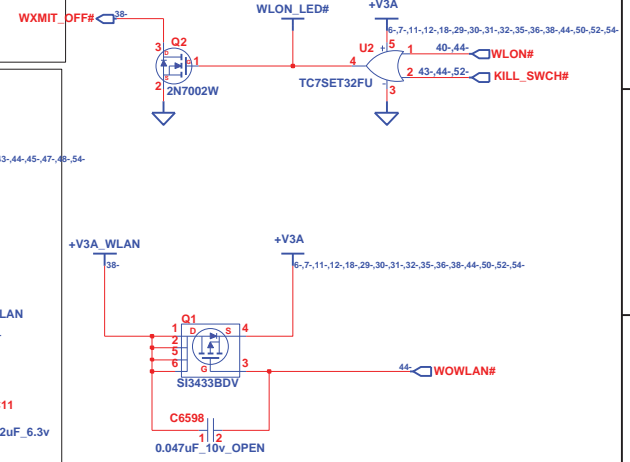
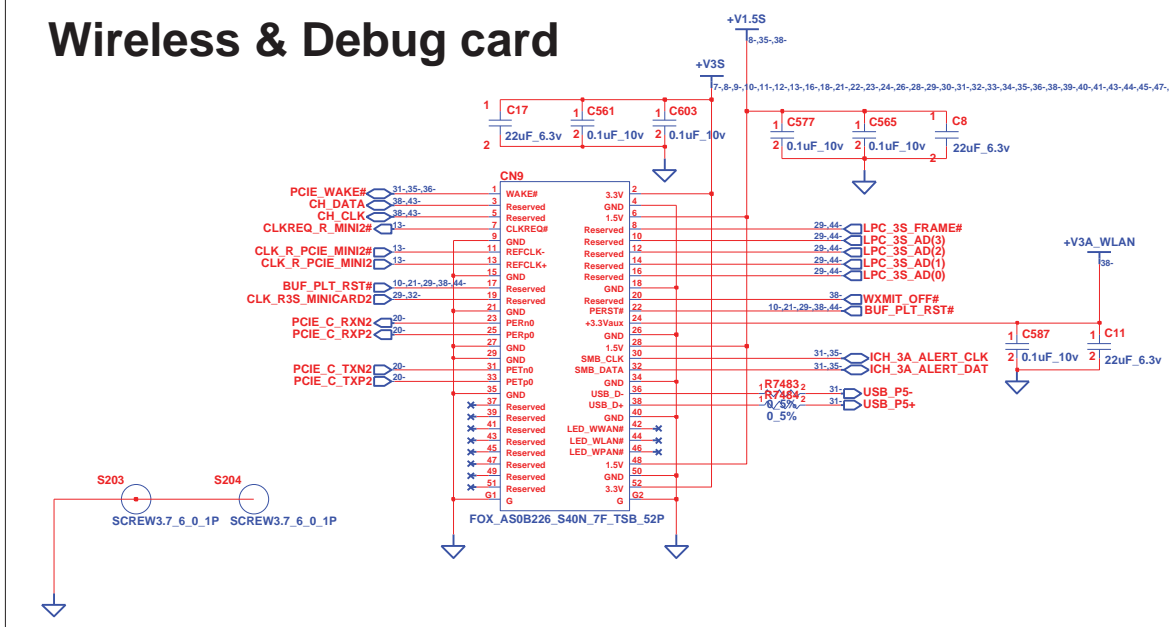

<http://laptop-motherboard-schematic.blogspot.com/>

INVENTEC			
TITLE MW10A Robson & WLAN			
SIZE A3	CODE CS	DOC. NUMBER Model No	REV X01
CHANGE by <i>Kobe</i>		9-Mar-2007	
SHEET 38		OF 54	

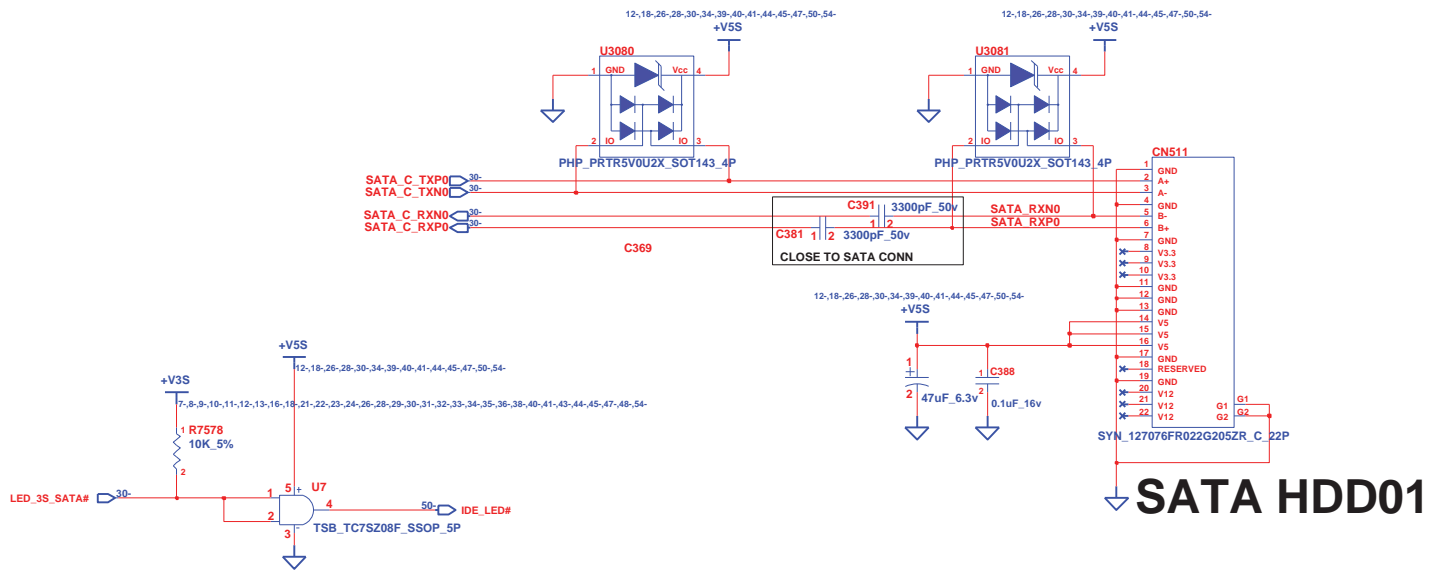

SATA HDD01

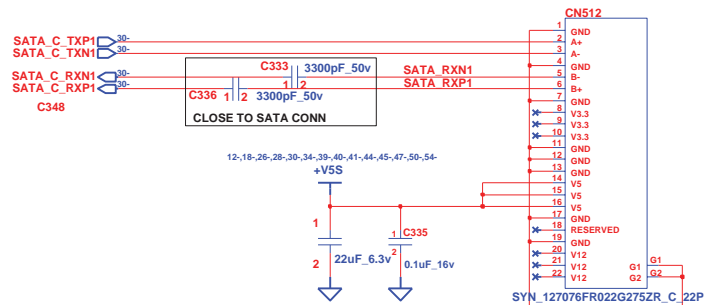

SATA HDD02

<http://laptop-motherboard-schematic.blogspot.com/>

INVENTEC

TITLE			
MW10A			
SATA HDD CONN			
SIZE	CODE	DOC. NUMBER	REV
A3	CS	Model No	X01
CHANGE by		6-Jul-2007	
Kobe		SHEET 39 OF 54	

1 2 3 4 5 6 7 8

A

B

C

D

E

F

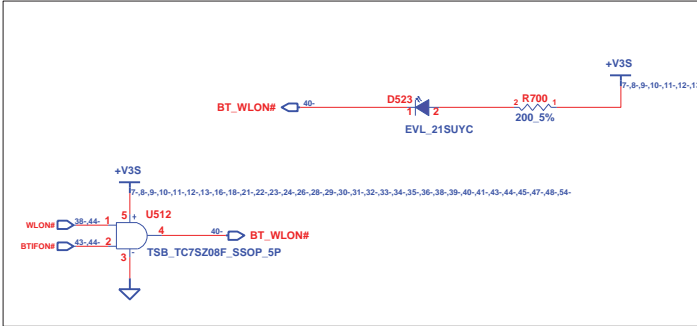
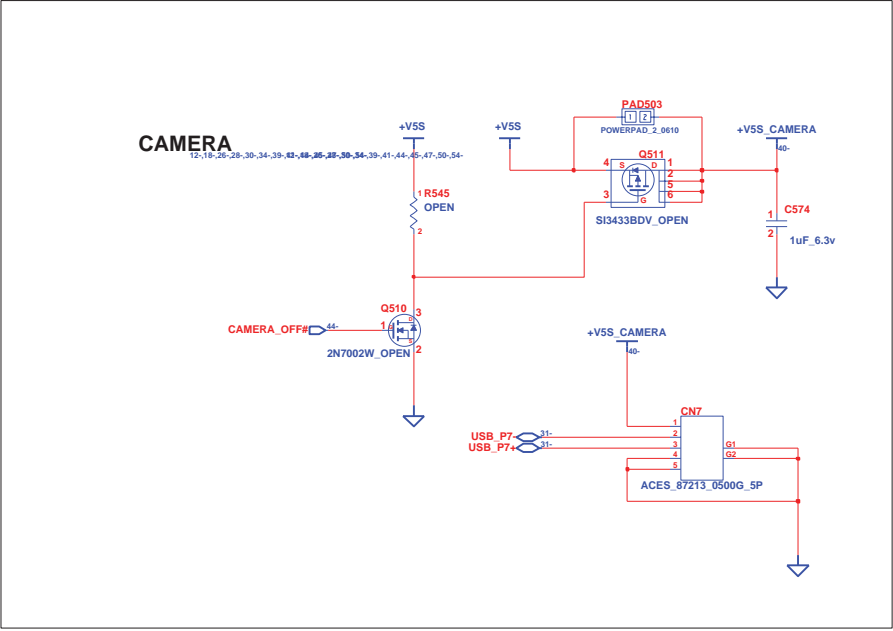
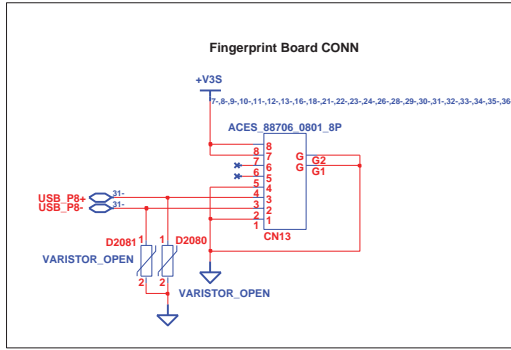

<http://laptop-motherboard-schematic.blogspot.com/>

INVENTEC			
TITLE MW10A			
Filica & Finger Printer & Camera			
SIZE	CODE	DOC. NUMBER	REV
A3	CS	Model No	X01
CHANGE by <i>Kobe</i>		22-Mar-2007	SHEET 40 OF 54
		7	8

1 2 3 4 5 6 7 8

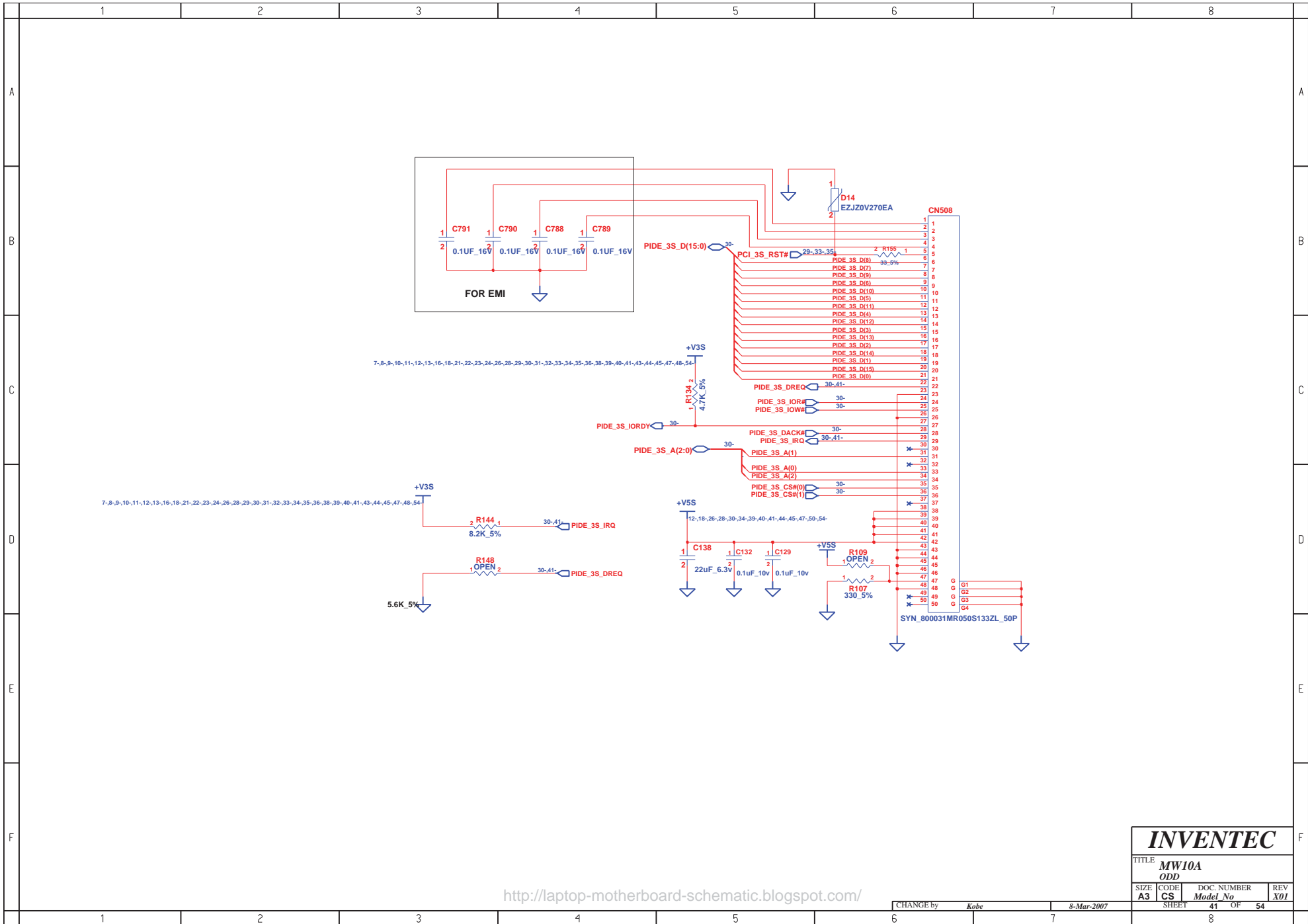

<http://laptop-motherboard-schematic.blogspot.com/>

INVENTEC

TITLE			
MW10A			
ODD			
SIZE	CODE	DOC. NUMBER	REV
A3	CS	Model No	X01

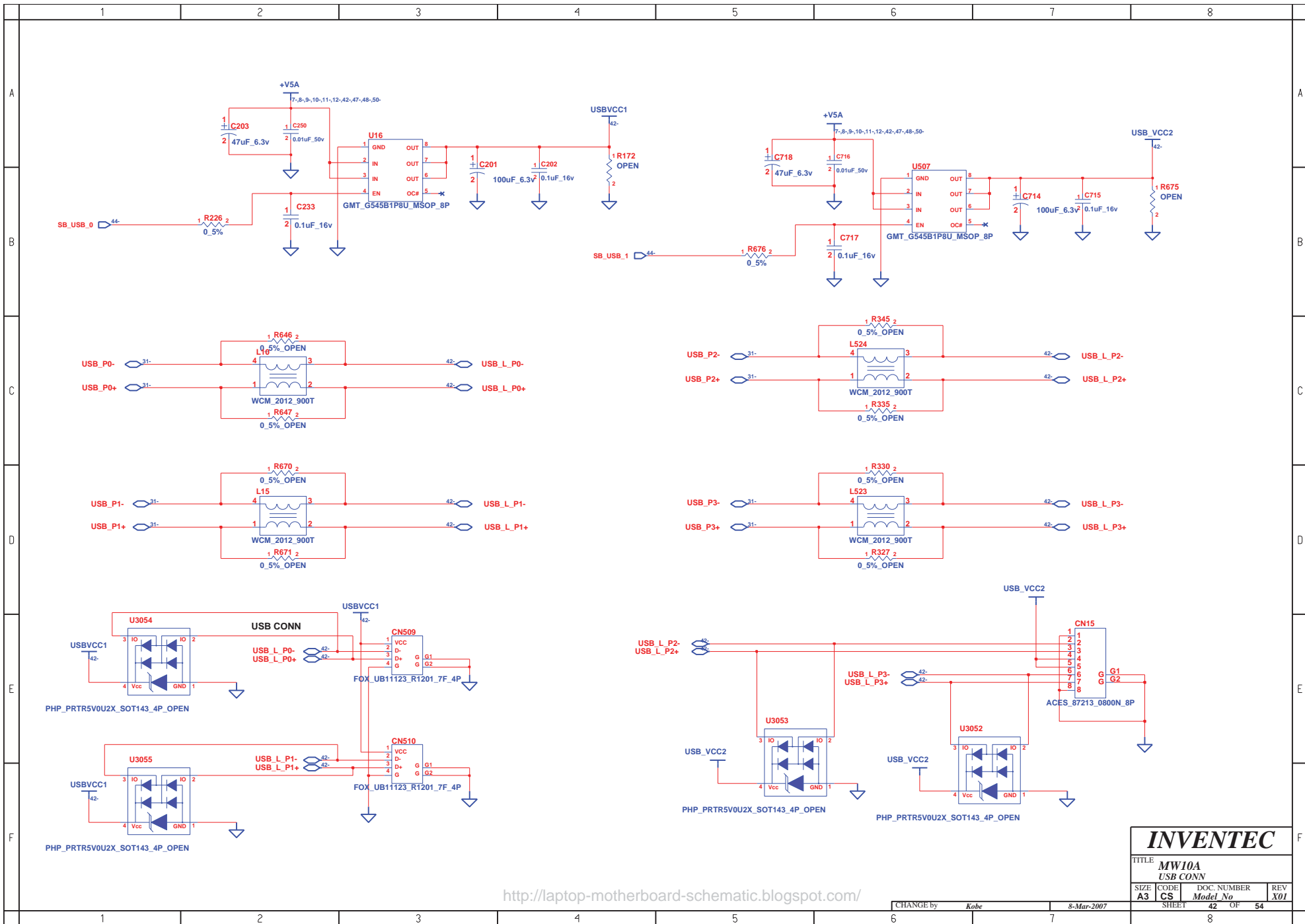

<http://laptop-motherboard-schematic.blogspot.com/>

INVENTEC			
TITLE MW10A USB CONN			
SIZE A3	CODE CS	DOC. NUMBER <i>Model No</i>	REV X01
CHANGE by <i>Kobe</i>		8-Mar-2007	
SHEET 42 OF 54		8	

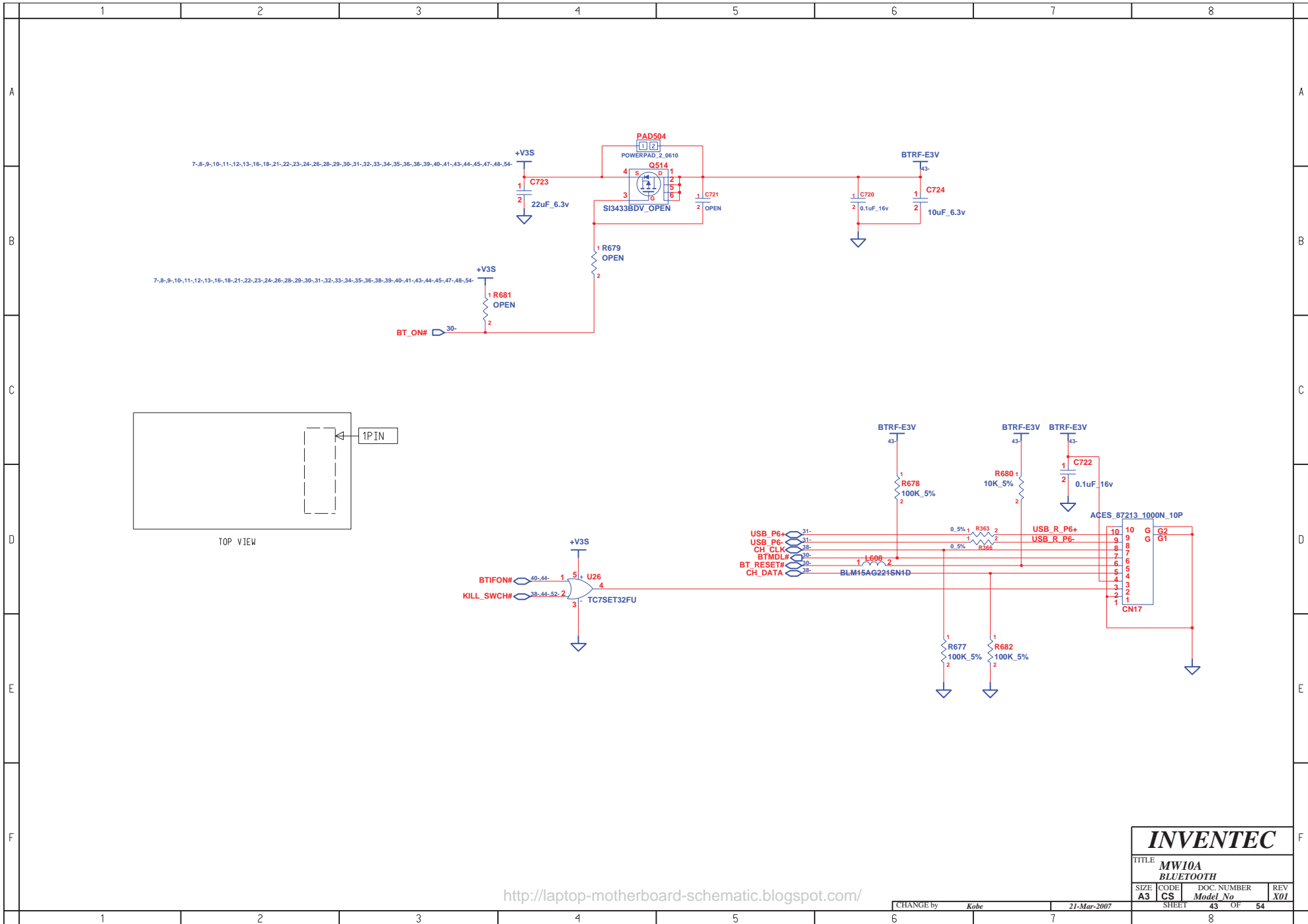

<http://laptop-motherboard-schematic.blogspot.com/>

INVENTEC			
TITLE MW10A BLUETOOTH			
SIZE A3	CODE CS	DOC. NUMBER <i>Model No</i>	REV X01
SHEET 43 OF 54		8	

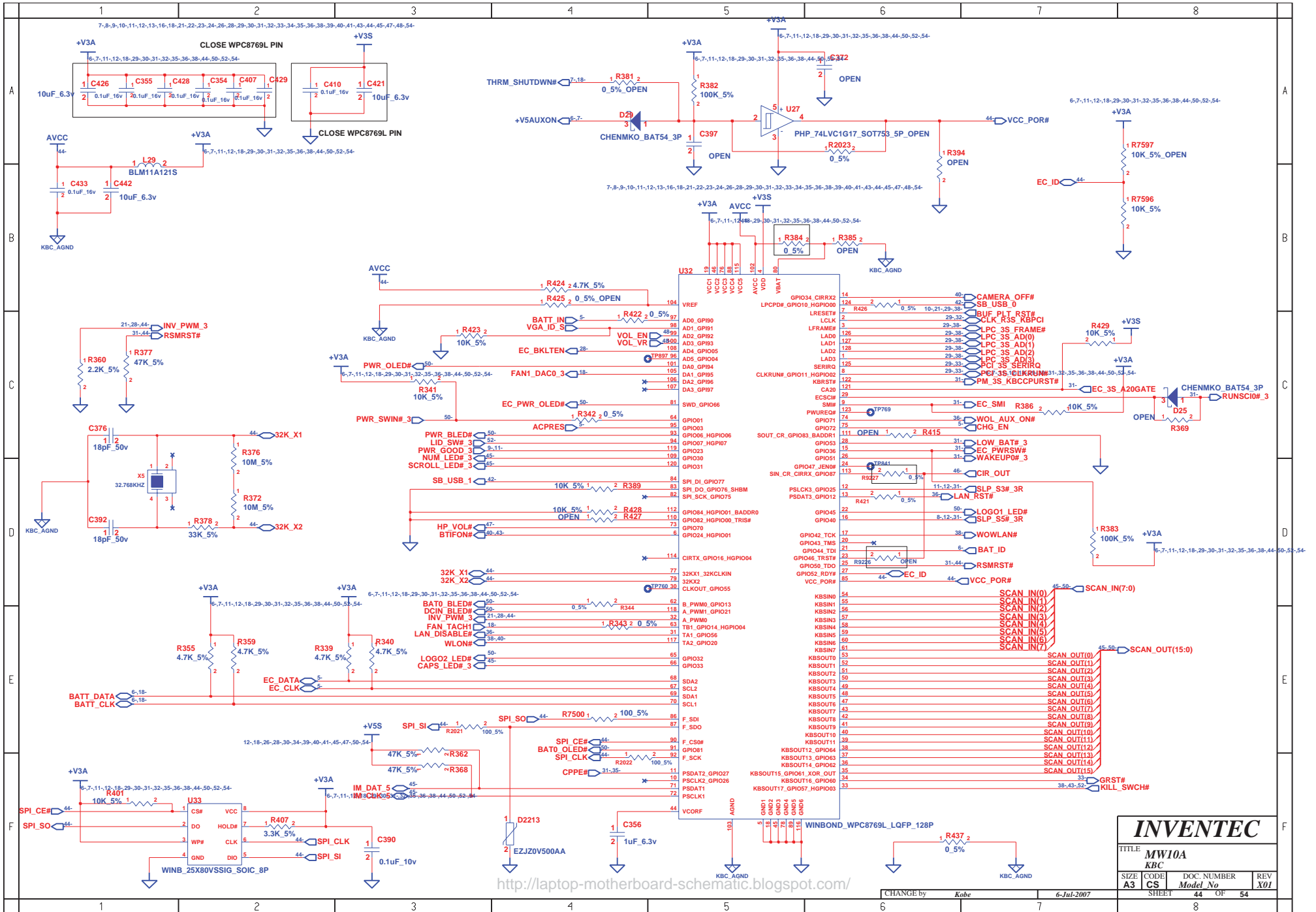

INVENTEC			
TITLE: MW10A KBC			
SIZE: A3	CODE: CS	DOC. NUMBER: Model No	REV: X01
SHEET: 44		OF 54	

CHANGE by Kobe 6-Jul-2007

<http://laptop-motherboard-schematic.blogspot.com/>

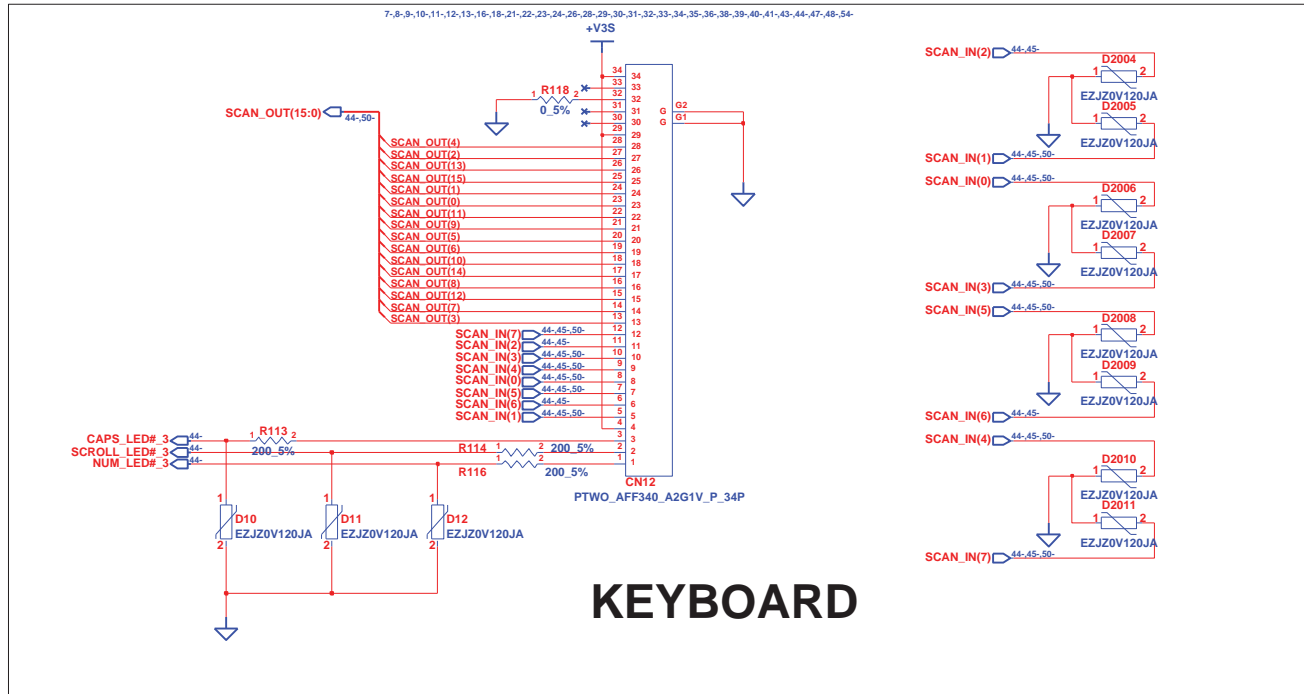

KEYBOARD

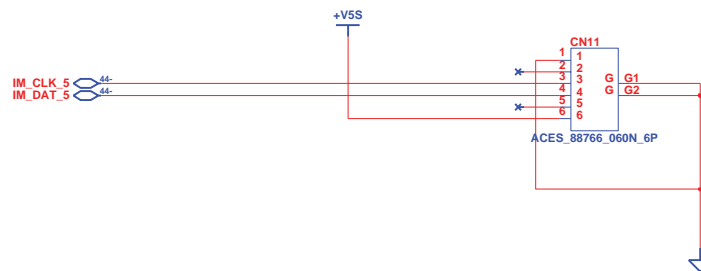

<http://laptop-motherboard-schematic.blogspot.com/>

INVENTEC			
TITLE MW10A INT.KBC/POINT DEVICES			
SIZE A3	CODE CS	DOC. NUMBER Model No	REV X01
CHANGE by <i>Kobe</i>		16-Mar-2007	SHEET 45 OF 54

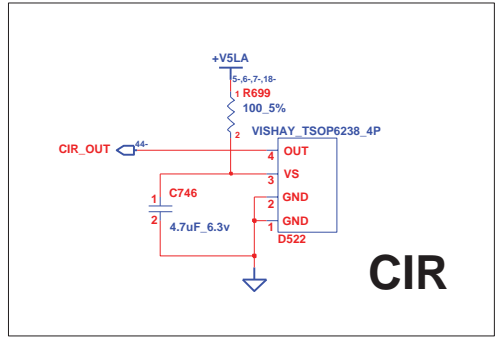

<http://laptop-motherboard-schematic.blogspot.com/>

INVENTEC			
TITLE			
MW10A			
CIR & HDMI CONN			
SIZE	CODE	DOC. NUMBER	REV
A3	CS	Model No	X01
CHANGE by		8-Mar-2007	SHEET 46 OF 54
		Kobe	8

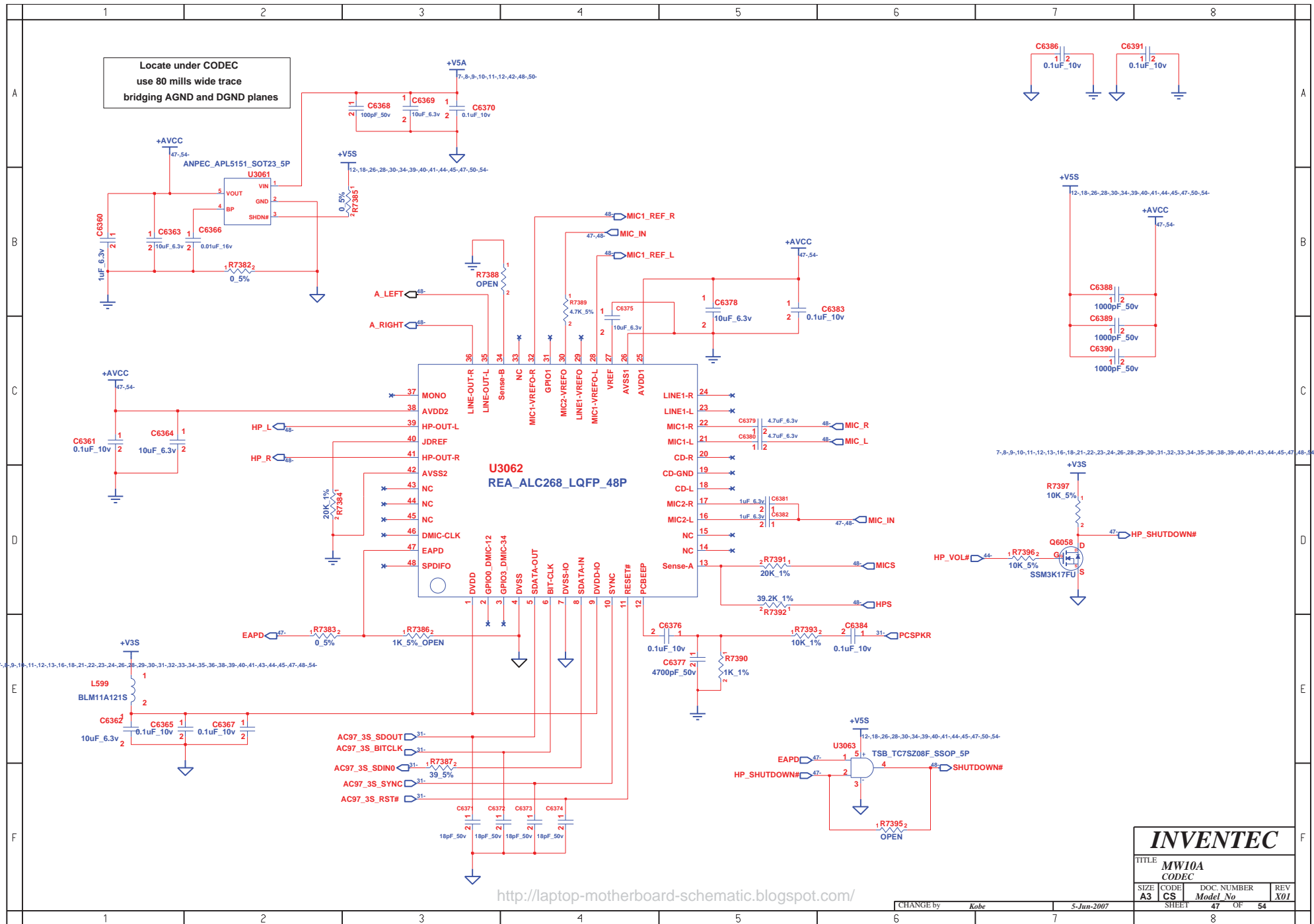

Locate under CODEC
use 80 mills wide trace
bridging AGND and DGND planes

<http://laptop-motherboard-schematic.blogspot.com/>

INVENTEC			
TITLE MW10A CODEC			
SIZE A3	CODE CS	DOC. NUMBER Model No	REV X01
CHANGE by <i>Kobe</i>		5-Jun-2007	SHEET 47 OF 54

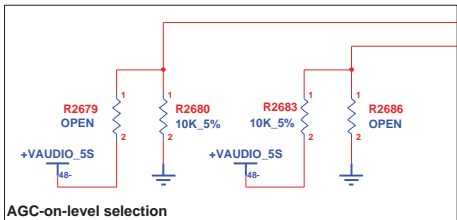
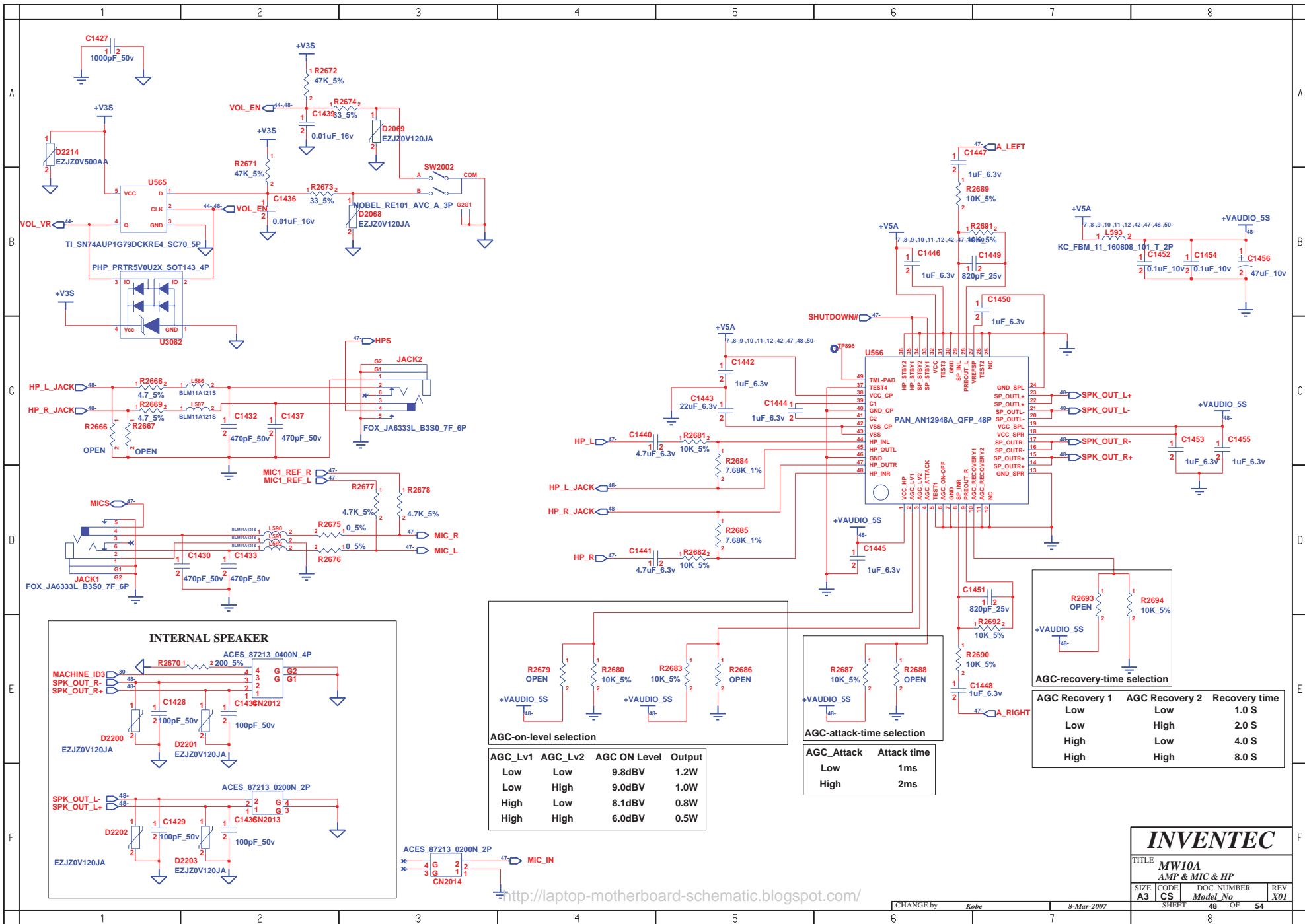

AGC-on-level selection

AGC_Lv1	AGC_Lv2	AGC ON Level	Output
Low	Low	9.8dBV	1.2W
Low	High	9.0dBV	1.0W
High	Low	8.1dBV	0.8W
High	High	6.0dBV	0.5W

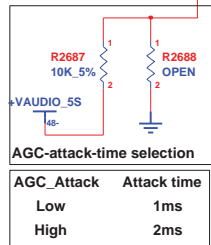

AGC-attack-time selection

AGC_Attack	Attack time
Low	1ms
High	2ms



AGC-recovery-time selection

AGC Recovery 1	AGC Recovery 2	Recovery time
Low	Low	1.0 S
Low	High	2.0 S
High	Low	4.0 S
High	High	8.0 S

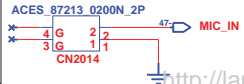
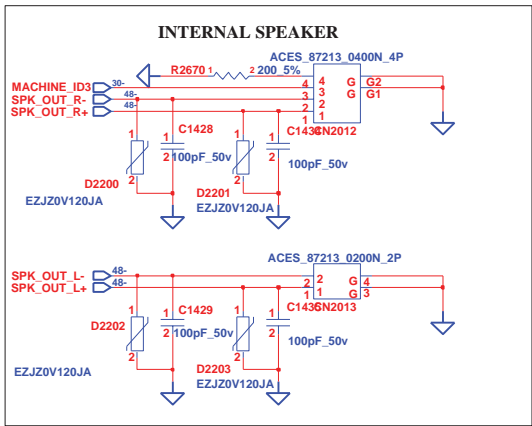

INVENTEC

TITLE MW10A AMP & MIC & HP			
SIZE A3	CODE CS	DOC. NUMBER Model No	REV X01
CHANGE by <i>Kobe</i>		8-Mar-2007	
SHEET 48		OF 54	

<http://laptop-motherboard-schematic.blogspot.com/>

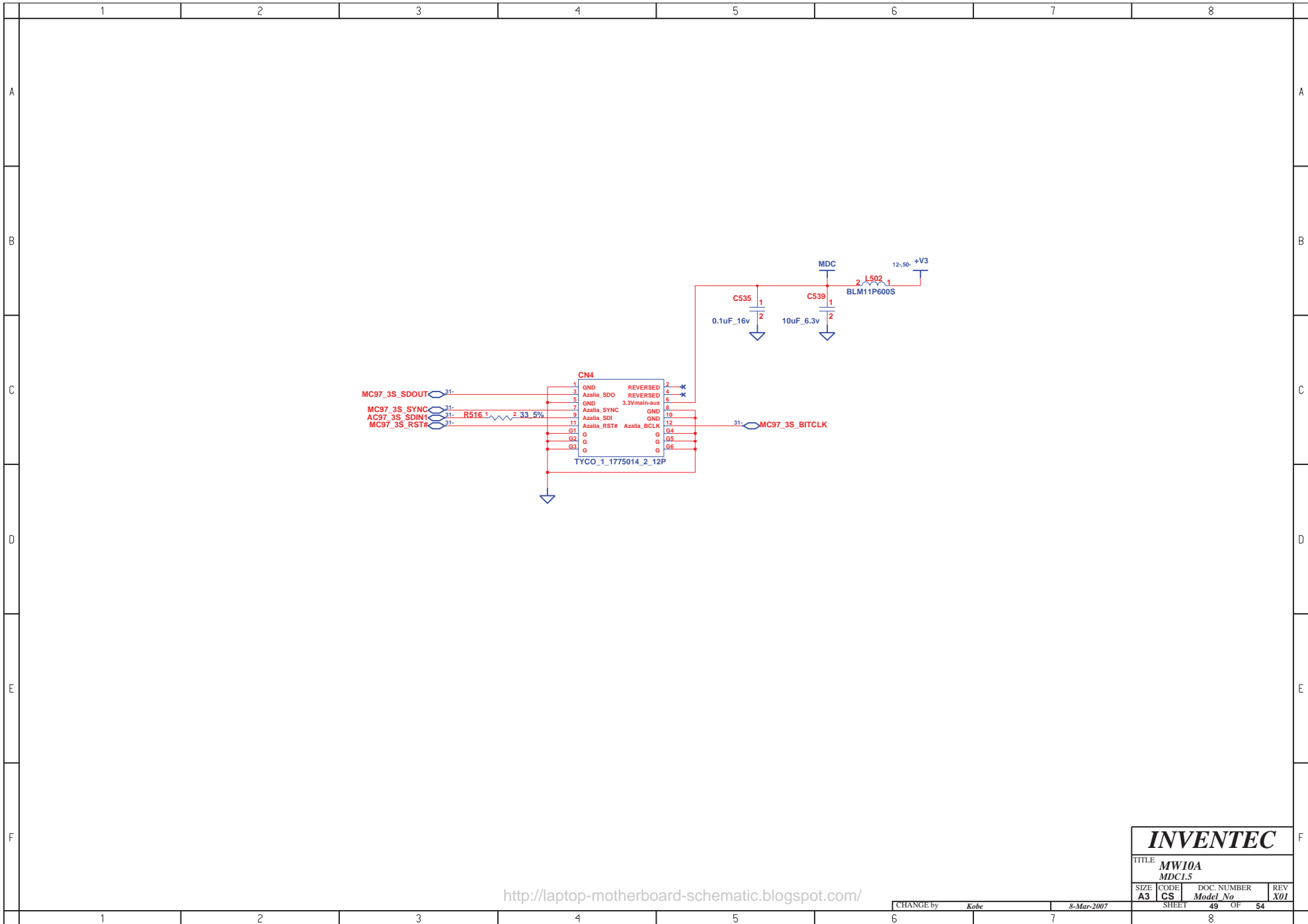

<http://laptop-motherboard-schematic.blogspot.com/>

INVENTEC			
TITLE			
MW10A			
MDCL5			
SIZE	CODE	DOC. NUMBER	REV
A3	CS	<i>Model No</i>	X01
CHANGE by <i>Kobe</i>		8-Mar-2007	SHEET 49 OF 54
1	2	3	8

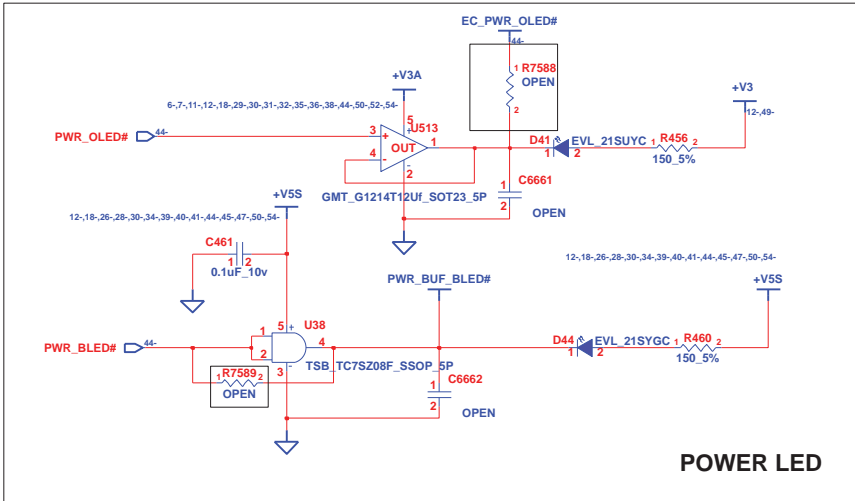

POWER LED

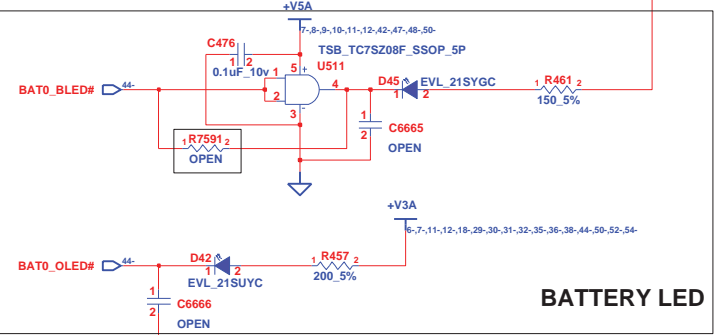
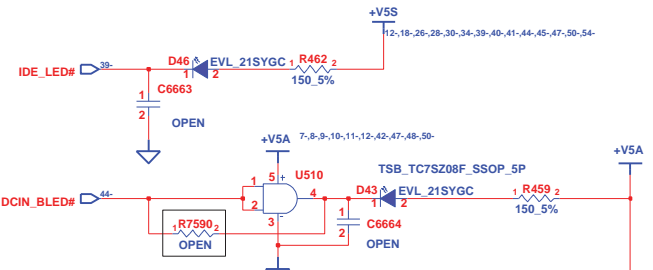
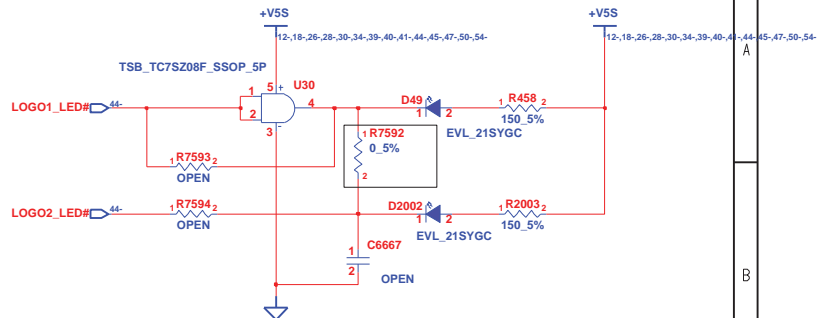

BATTERY LED

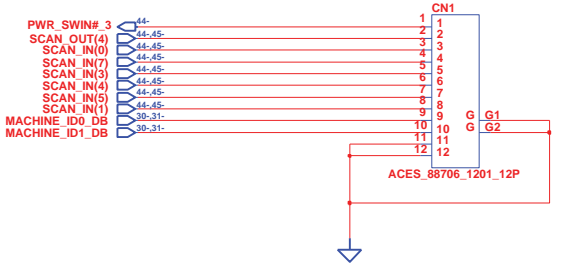

INVENTEC

TITLE			
MW10A			
LED			
SIZE	CODE	DOC. NUMBER	REV
A3	CS	Model No	X01

<http://laptop-motherboard-schematic.blogspot.com/>

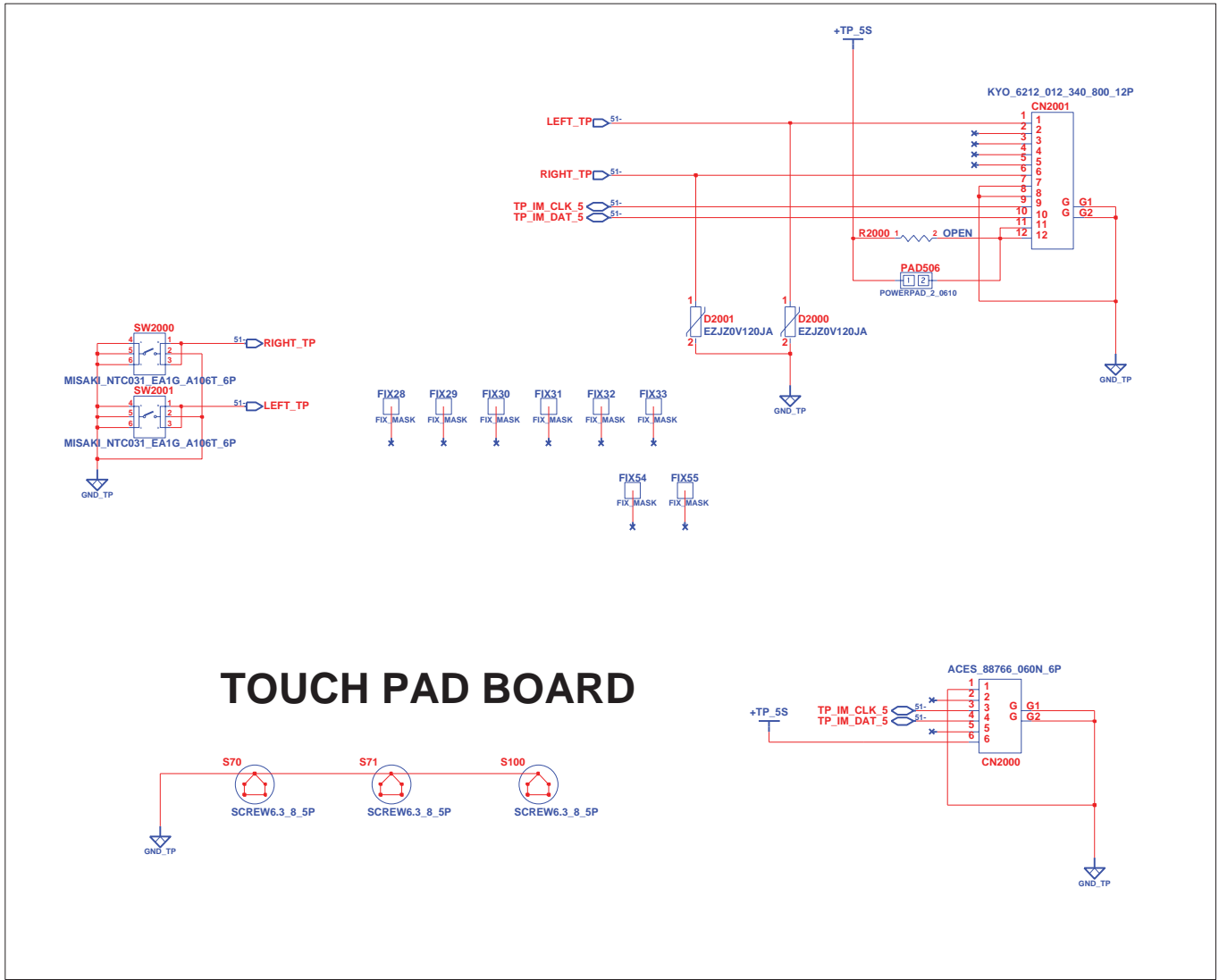

TOUCH PAD BOARD

INVENTEC

TITLE			
MW10A			
Touch Pad Board			
SIZE	CODE	DOC. NUMBER	REV
A3	CS	Model No	X01
CHANGE by		8-Mar-2007	SHEET 51 OF 54

<http://laptop-motherboard-schematic.blogspot.com/>

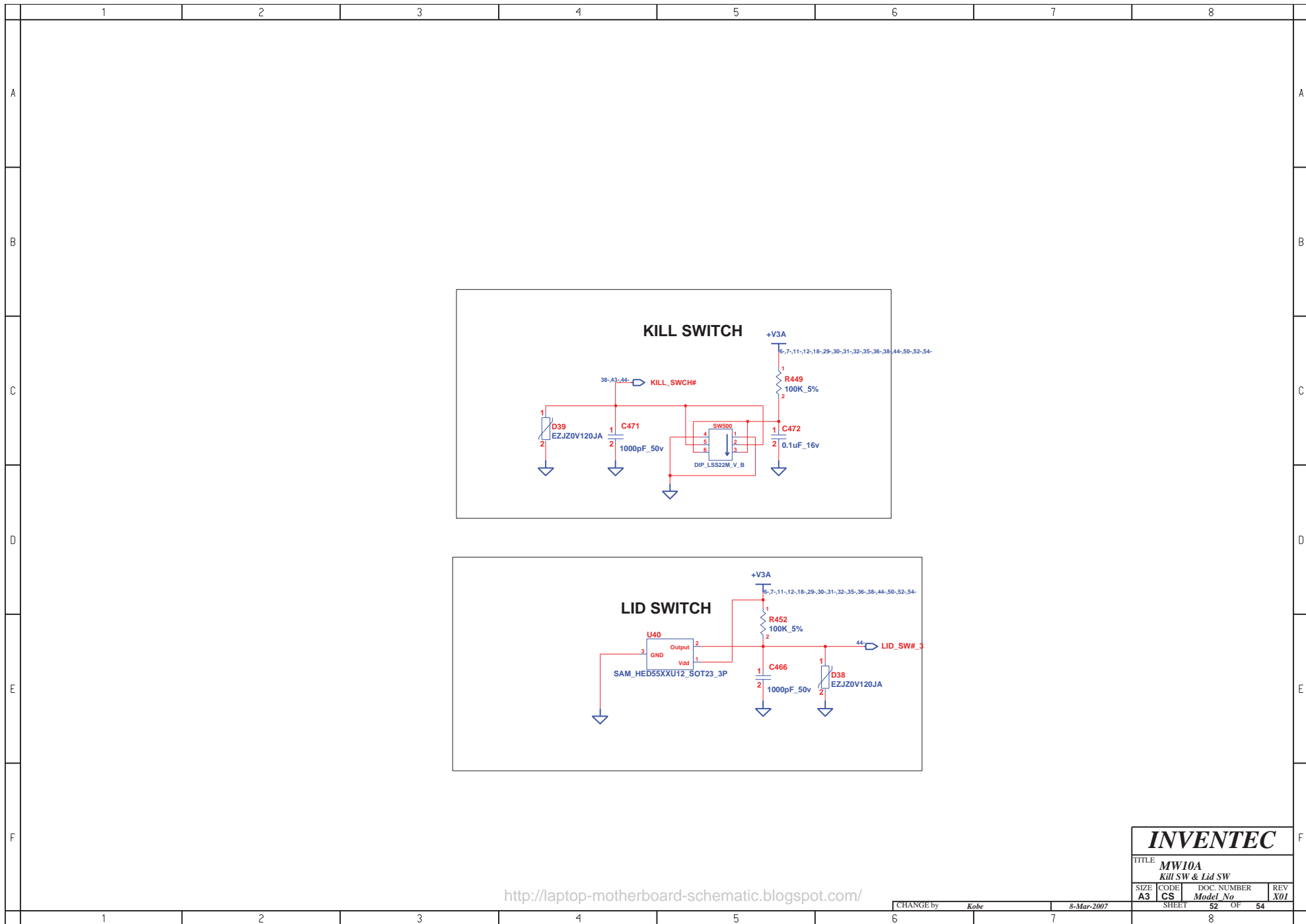

<http://laptop-motherboard-schematic.blogspot.com/>

CHANGE by *Kobe* 8-Mar-2007

INVENTEC			
TITLE			
<i>MW10A</i>			
<i>Kill SW & Lid SW</i>			
SIZE	CODE	DOC. NUMBER	REV
A3	CS	Model No	X01
SHEET		52	OF 54
		8	

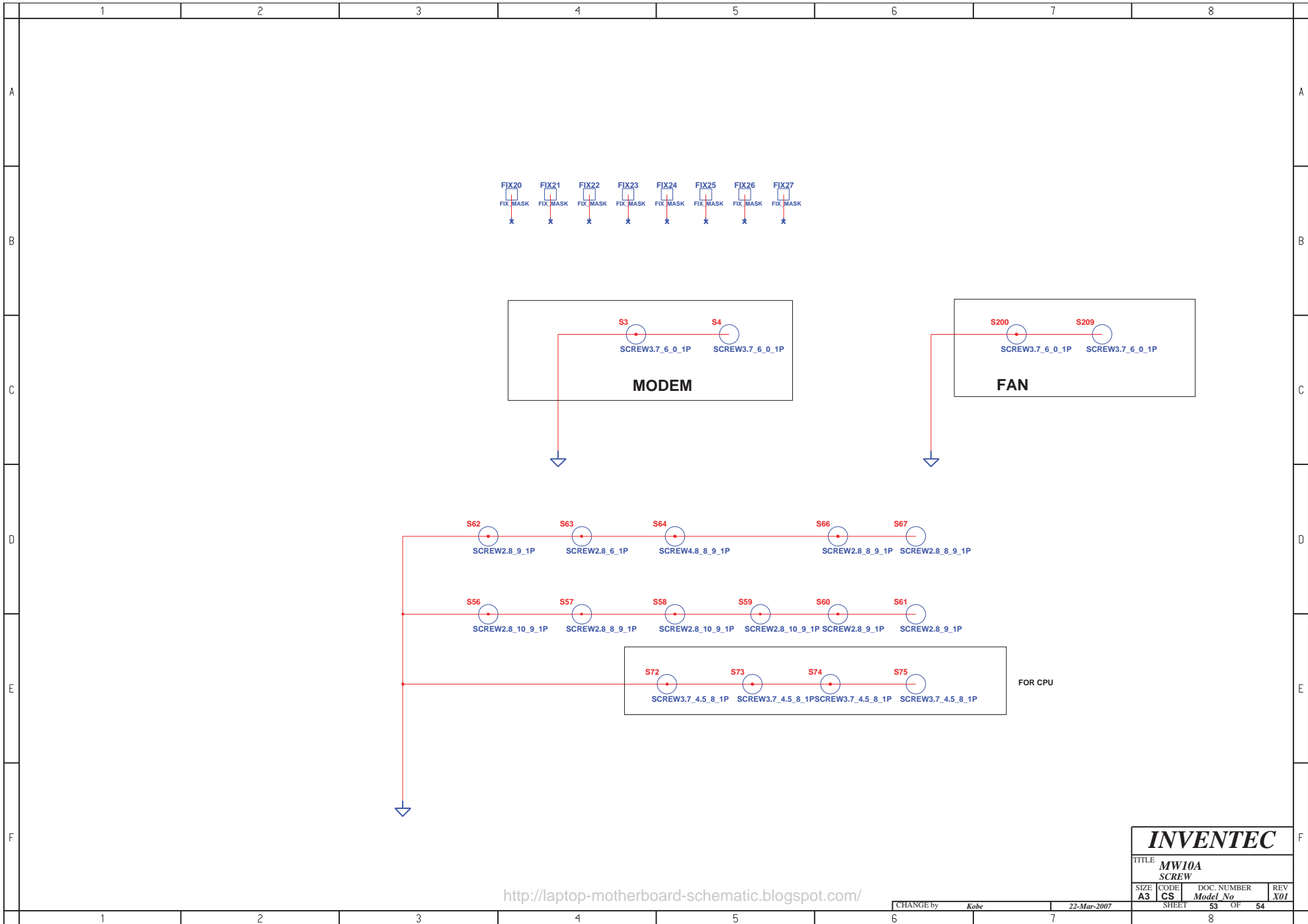

<http://laptop-motherboard-schematic.blogspot.com/>

INVENTEC			
TITLE MW10A SCREW			
SIZE A3	CODE CS	DOC. NUMBER <i>Model No</i>	REV X01
CHANGE by <i>Kobe</i>		22-Mar-2007	SHEET 53 OF 54

FOR EMI

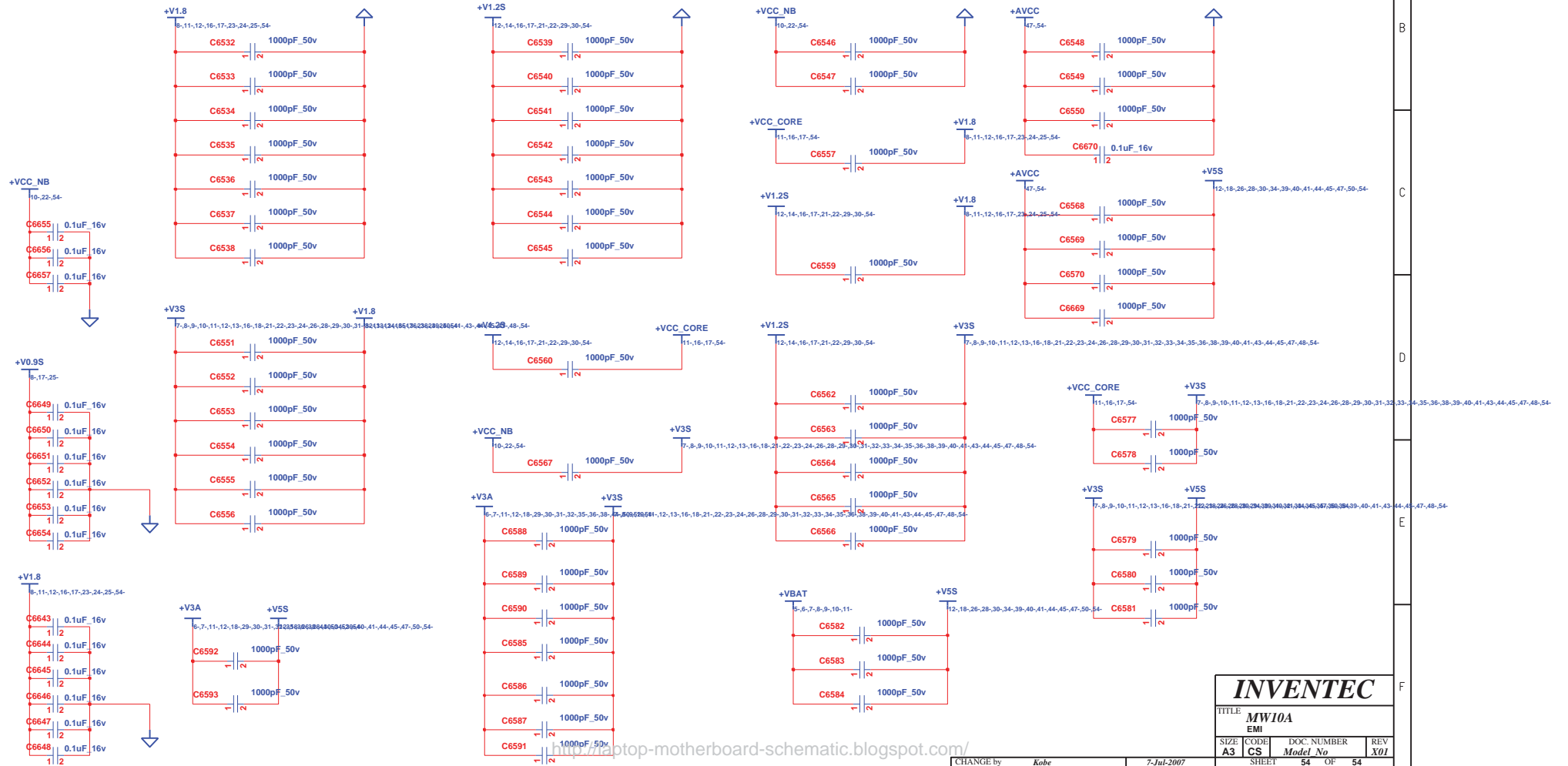

INVENTEC

TITLE: MW10A			
EMI			
SIZE: A3	CODE: CS	DOC. NUMBER: Model No	REV: X01

CHANGE by Kobe 7-Jul-2007

SHEET 54 OF 54

<http://laptop-motherboard-schematic.blogspot.com/>