

1 2 3 4 5 6 7 8

THIS DRAWING AND SPECIFICATIONS, HEREIN, ARE THE PROPERTY OF INVENTEC CORPORATION AND SHALL NOT BE REPRODUCED, COPIED, OR USED IN WHOLE OR IN PART AS THE BASIS FOR THE MANUFACTURE OR SALE OF ITEMS WITHOUT WRITTEN PERMISSION, INVENTEC CORPORATION 2009 ALL RIGHT RESERVED

HSF Property : **RoHS**

Manaus10R

Pre-MP Build(A02)

2011.03.21

DATE	CHANGE NO.	REV

DRAWER	EE	DATE	POWER	DATE	INVENTEC TITLE <i>Manaus10R</i> COVER
DESIGN	CHUANG, AMINE	2011-MAR-21	YU, MARK	2011-MAR-21	
CHECK	CHUANG, AMINE	2011-MAR-21	YU, MARK	2011-MAR-21	
RESPONSIBLE	CHUANG, AMINE	2011-MAR-21	YU, MARK	2011-MAR-21	
SIZE =	A3			VER : A02	
FILE NAME :	MN10R-6050A2423501-MB-A02				SIZE CODE A3 WS
P/N	6050A2423501				DOC. NUMBER 310A2423501-0-MTR
				SHEET	1 OF 58

TABLE OF CONTENTS

<p>PAGE</p> <p>1. COVER PAGE</p> <p>2. INDEX</p> <p>3. BLOCK DIAGRAM</p> <p>4. POWER SEQUENCE BLOCK</p> <p>5. PCB SCREW</p> <p>6. SYSTEM POWER</p> <p>7. SYSTEM POWER</p> <p>8. SYSTEM POWER</p> <p>9. SYSTEM POWER</p> <p>10. SYSTEM POWER</p> <p>11. SYSTEM POWER</p> <p>12. SYSTEM POWER</p> <p>13. BLANK</p> <p>14. SYSTEM POWER</p> <p>15. EC</p> <p>16. K/B TP/B CONN</p> <p>17. FAN & THERMAL</p> <p>18. LAN</p> <p>19. RJ45 & TRANSFORMER</p> <p>20. AUDIO CODEC</p> <p>21. AUDIO JACK & INTERNAL SPEAKER</p> <p>22. SKIP</p> <p>23. LCM CONN</p> <p>24. CRT CONN</p> <p>25. SKIP</p> <p>26. SKIP</p> <p>27. SKIP</p>	<p>PAGE</p> <p>28. SATA HDD/SSD & ODD</p> <p>29. SKIP</p> <p>30. SKIP</p> <p>31. SKIP</p> <p>32. WLAN/DEBUG CARD</p> <p>33. SKIP</p> <p>34. HALL SENSOR</p> <p>35. LED</p> <p>36. SKIP</p> <p>37. DDR3 DIMM0</p> <p>38. DDR3 DIMM1</p> <p>39. CPU1</p> <p>40. CPU2</p> <p>41. CPU3</p> <p>42. CPU4</p> <p>43. CPU5</p> <p>44. CPU6</p> <p>45. PCH1</p> <p>46. PCH2</p> <p>47. PCH3</p> <p>48. PCH4</p> <p>49. PCH5</p> <p>50. PCH6</p> <p>51. PCH7</p> <p>52. PCH8</p> <p>53. PCH9</p> <p>54. PICK BUTTON</p>	<p>PAGE</p> <p>55. SKIP</p> <p>56. POWER BUTTON BOARD</p> <p>57. CARDREADER & USB</p> <p>58. EMI</p>
--	--	---

INVENTEC			
TITLE <i>Manaus10R</i>			
INDEX			
SIZE A3	CODE WS	DOC. NUMBER 1310A2423501-0-M1	REV RA
CHANGE by <i>Chuang, Amine</i>		21-Mar-2011	
SHEET 2		OF 58	

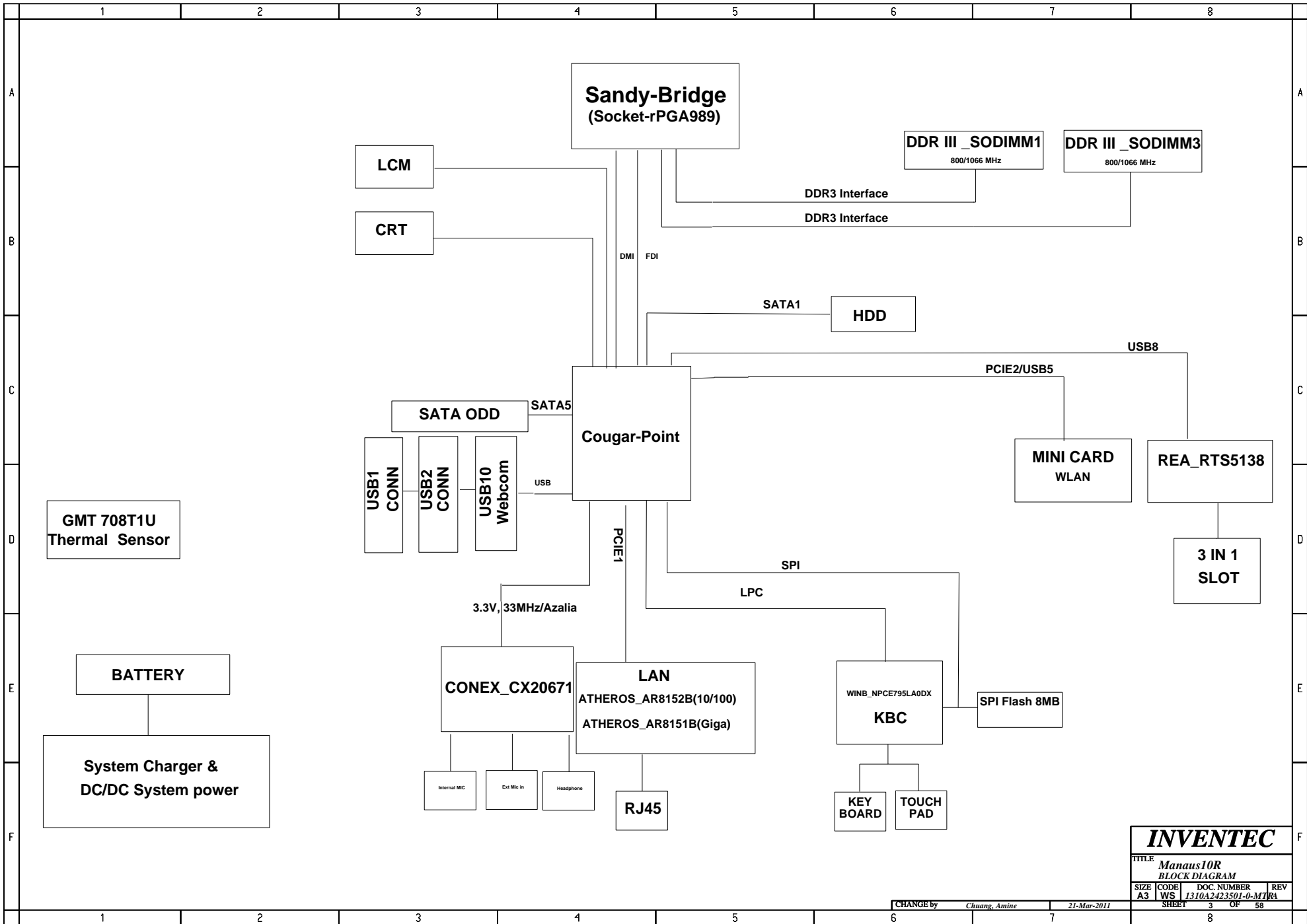

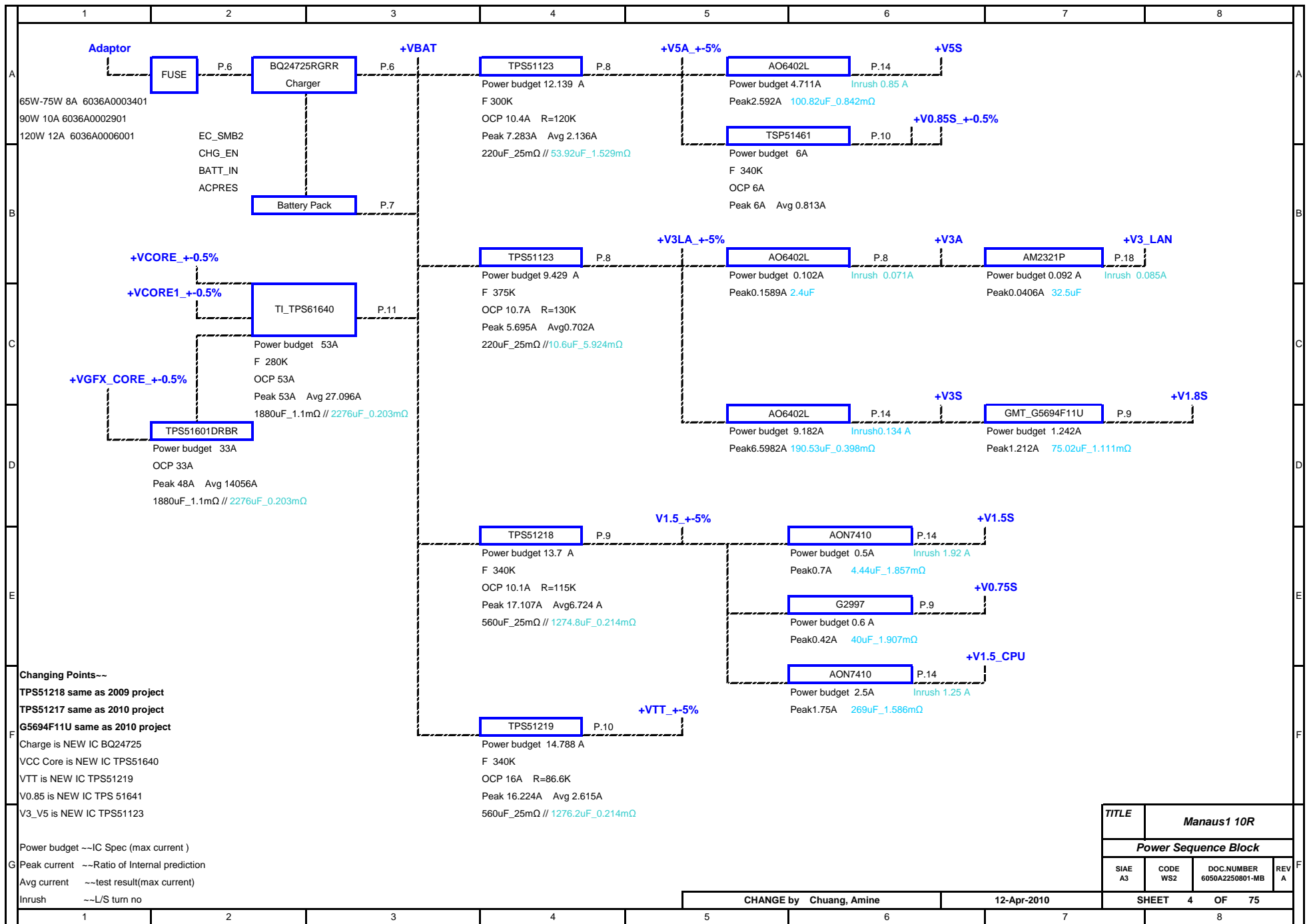

Changing Points--
 TPS51218 same as 2009 project
 TPS51217 same as 2010 project
 G5694F11U same as 2010 project
 Charge is NEW IC BQ24725
 VCC Core is NEW IC TPS51640
 VTT is NEW IC TPS51219
 V0.85 is NEW IC TPS 51641
 V3_V5 is NEW IC TPS51123

Power budget --IC Spec (max current)
 Peak current --Ratio of Internal prediction
 Avg current --test result(max current)
 Inrush --L/S turn no

TITLE		Manaus1 10R	
Power Sequence Block			
SIAE A3	CODE WS2	DOC.NUMBER 6050A2250801-MB	REV A
CHANGE by Chuang, Amine		12-Apr-2010	
SHEET 4		OF 75	

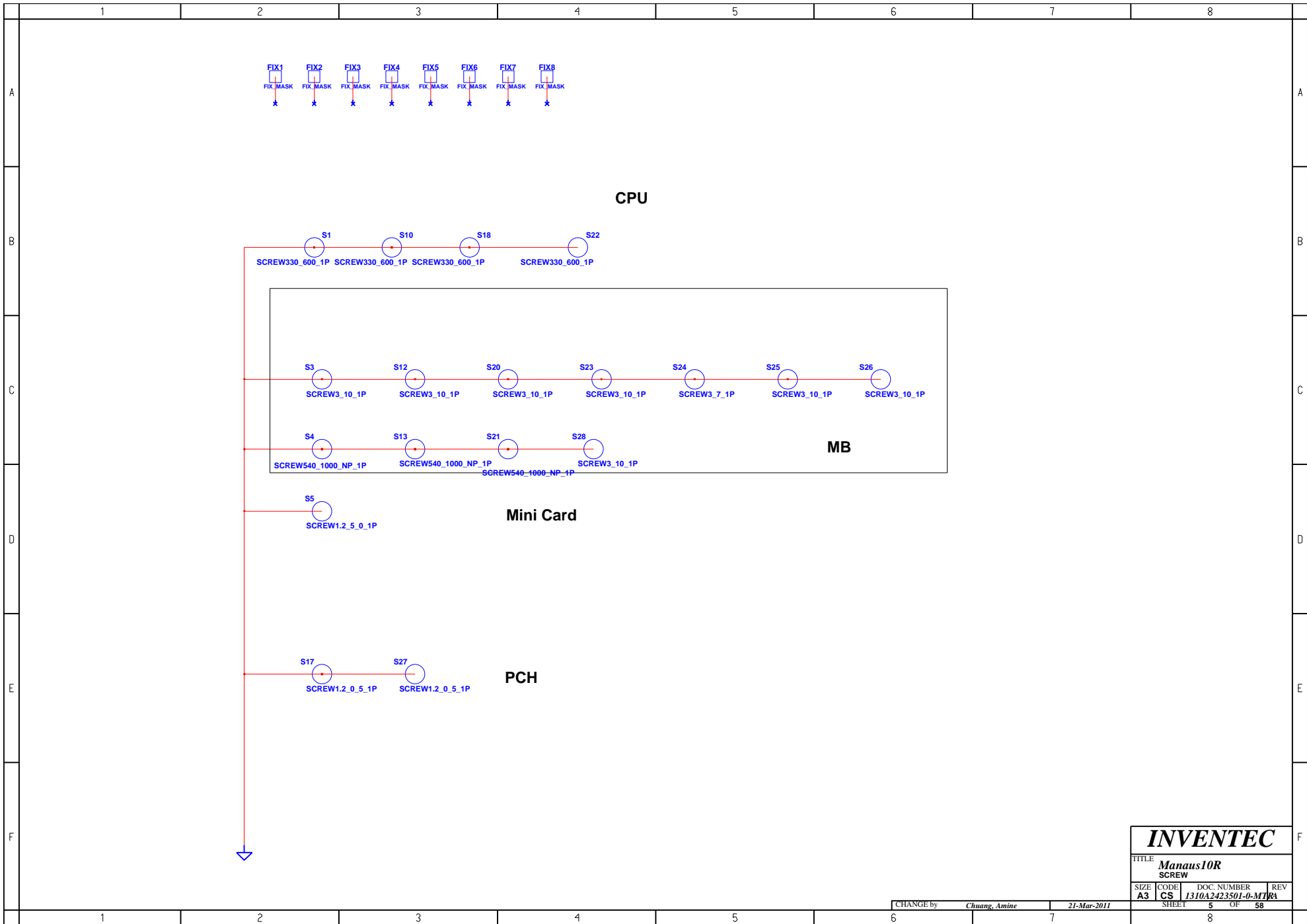

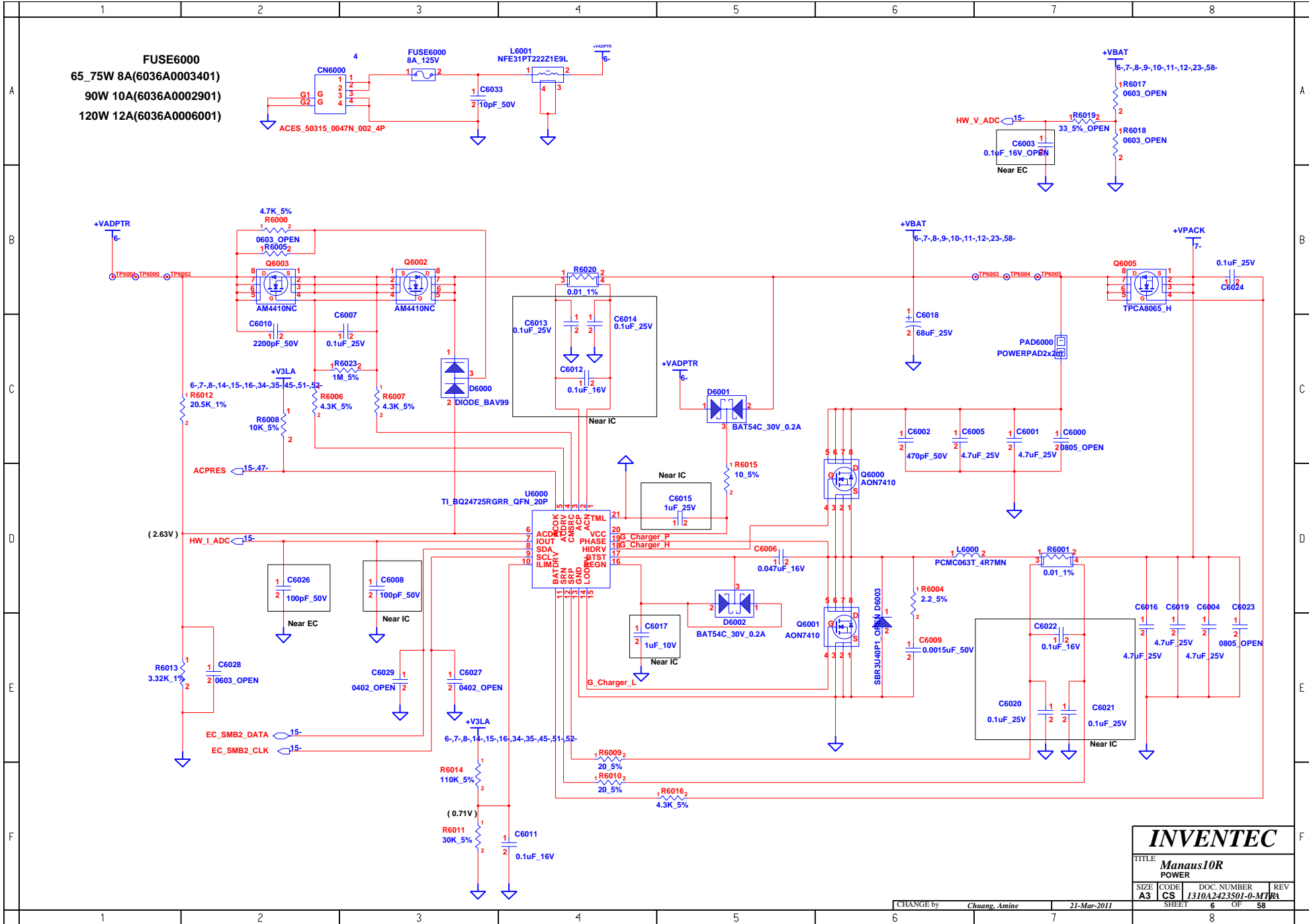

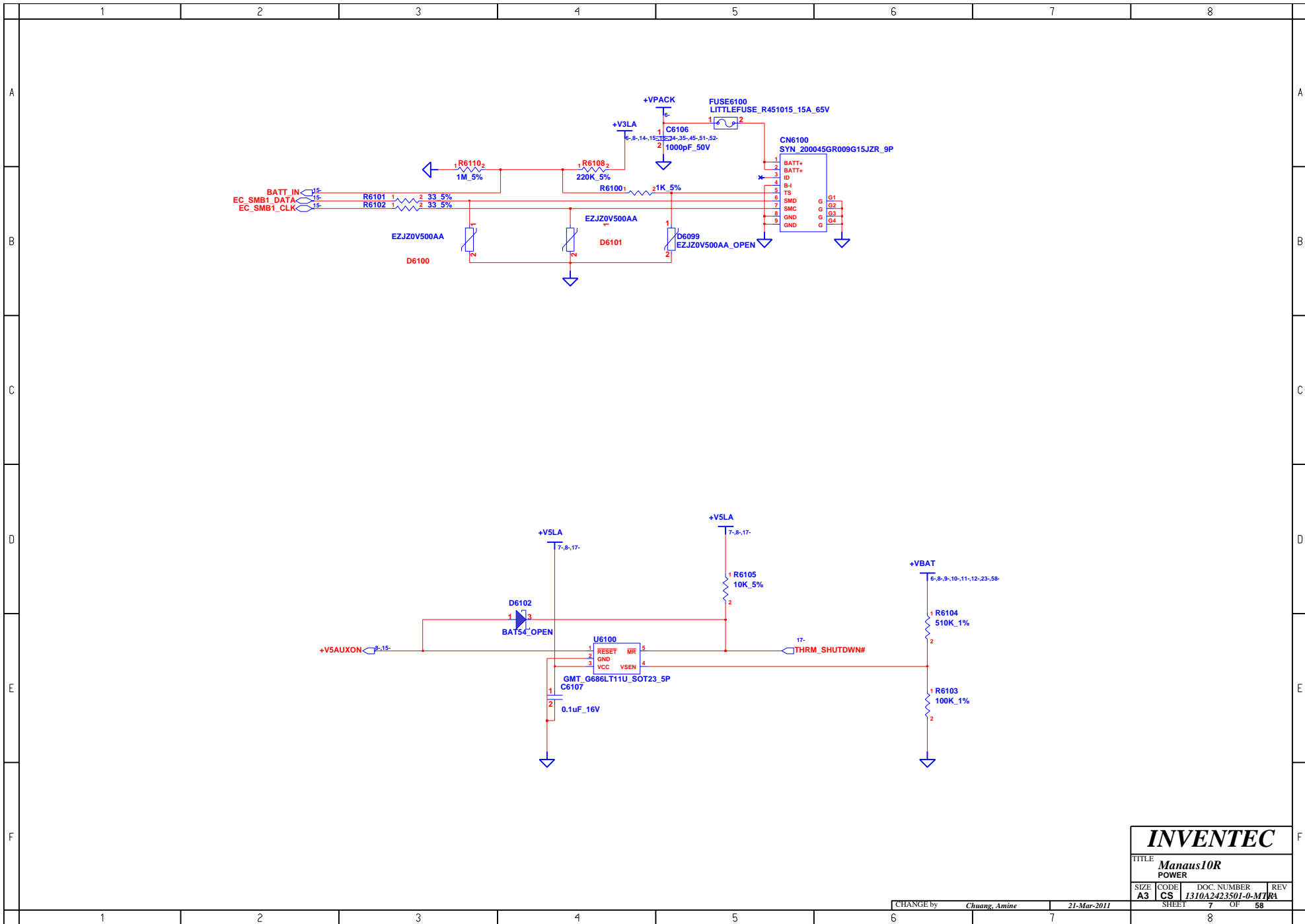

INVENTEC

TITLE			
Manaus10R			
POWER			
SIZE	CODE	DOC. NUMBER	REV
A3	CS	1310A2423501-0-M1	KA
SHEET		7	OF 58

CHANGE by *Chuang, Amine* 21-Mar-2011

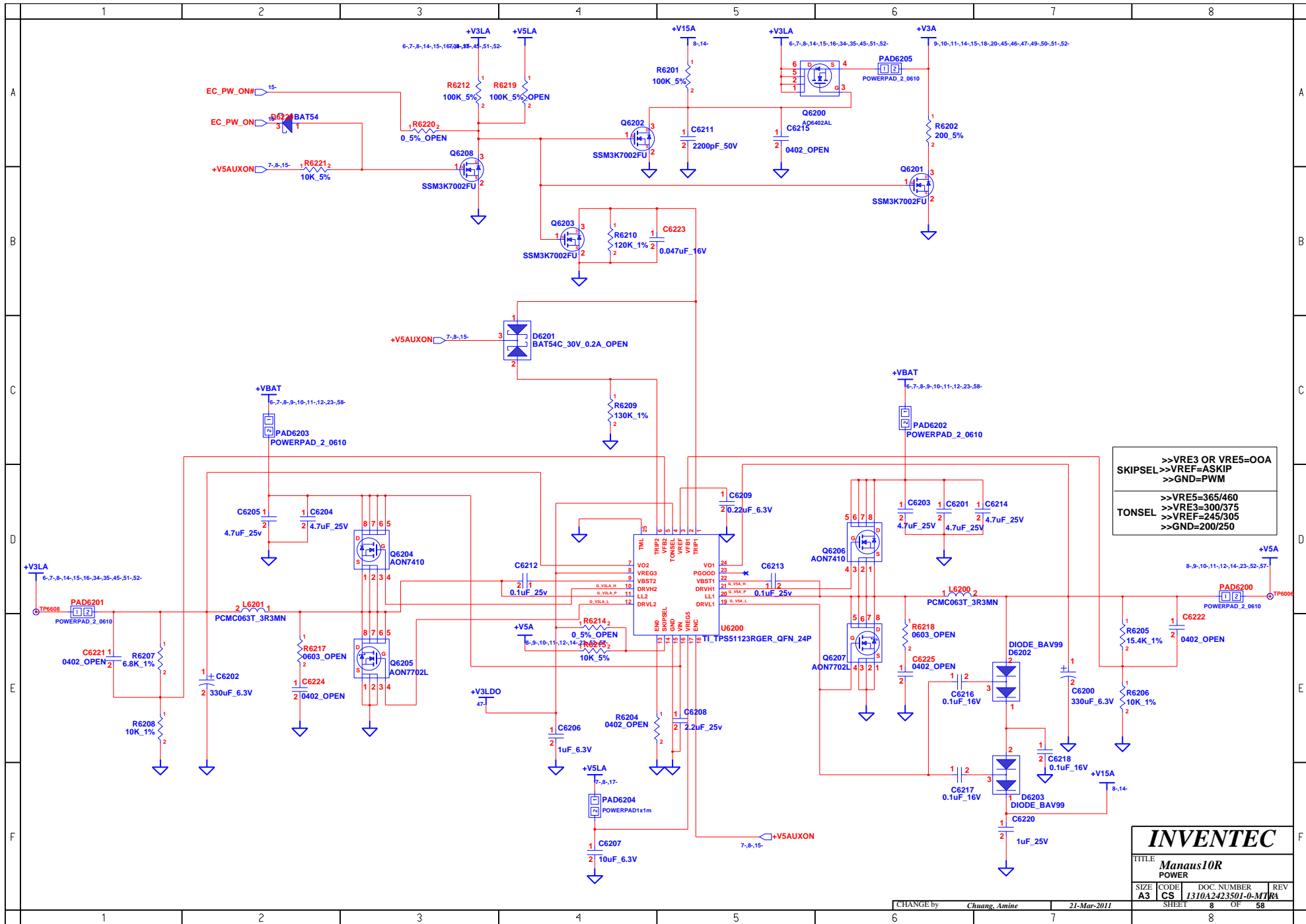

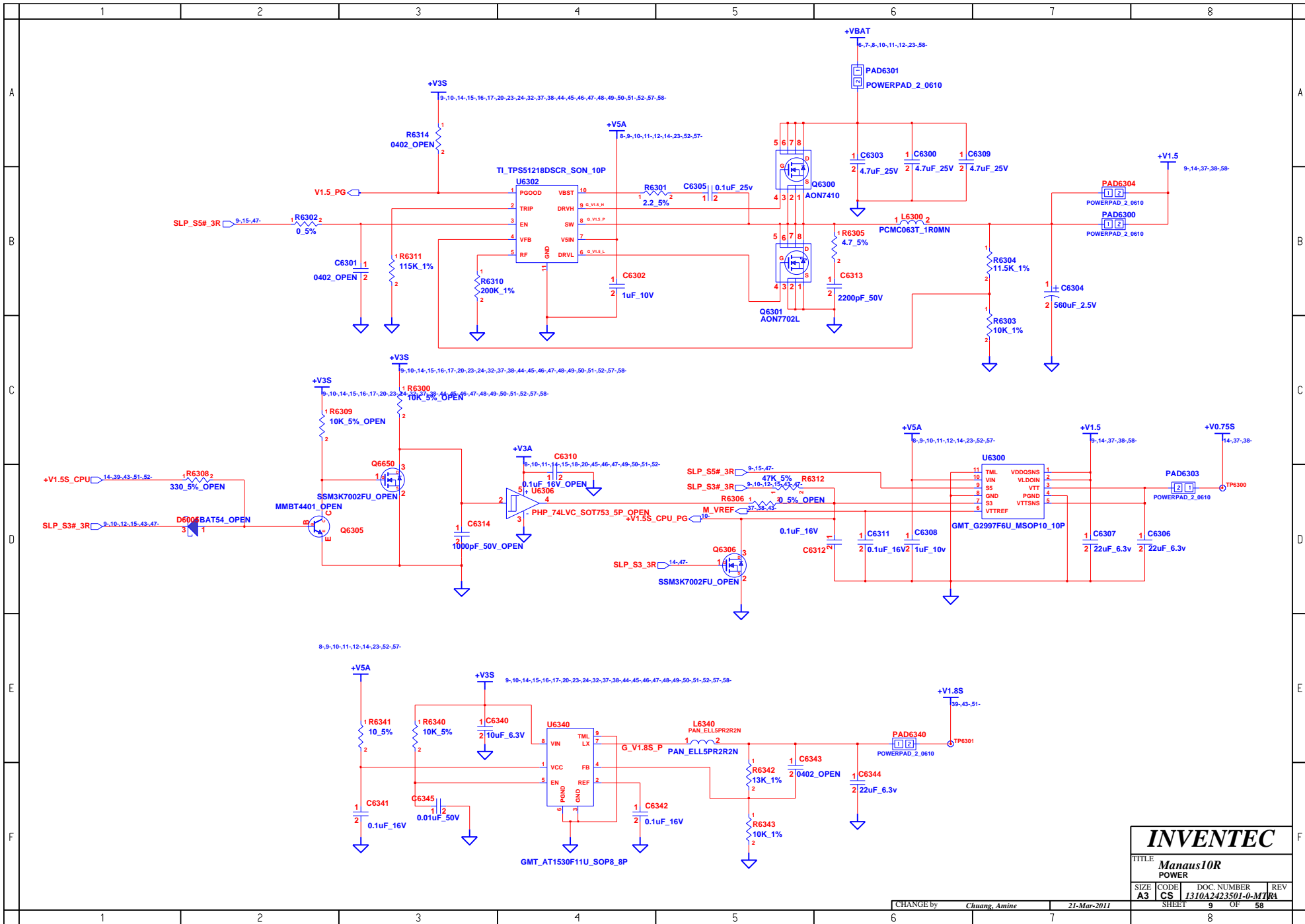

INVENTEC			
TITLE Manaus10R			
POWER			
SIZE A3	CODE CS	DOC. NUMBER 1310A2423501-0-MTR	REV
CHANGE by <i>Chuang, Amine</i>		21-Mar-2011	
SHEET 9		OF 58	

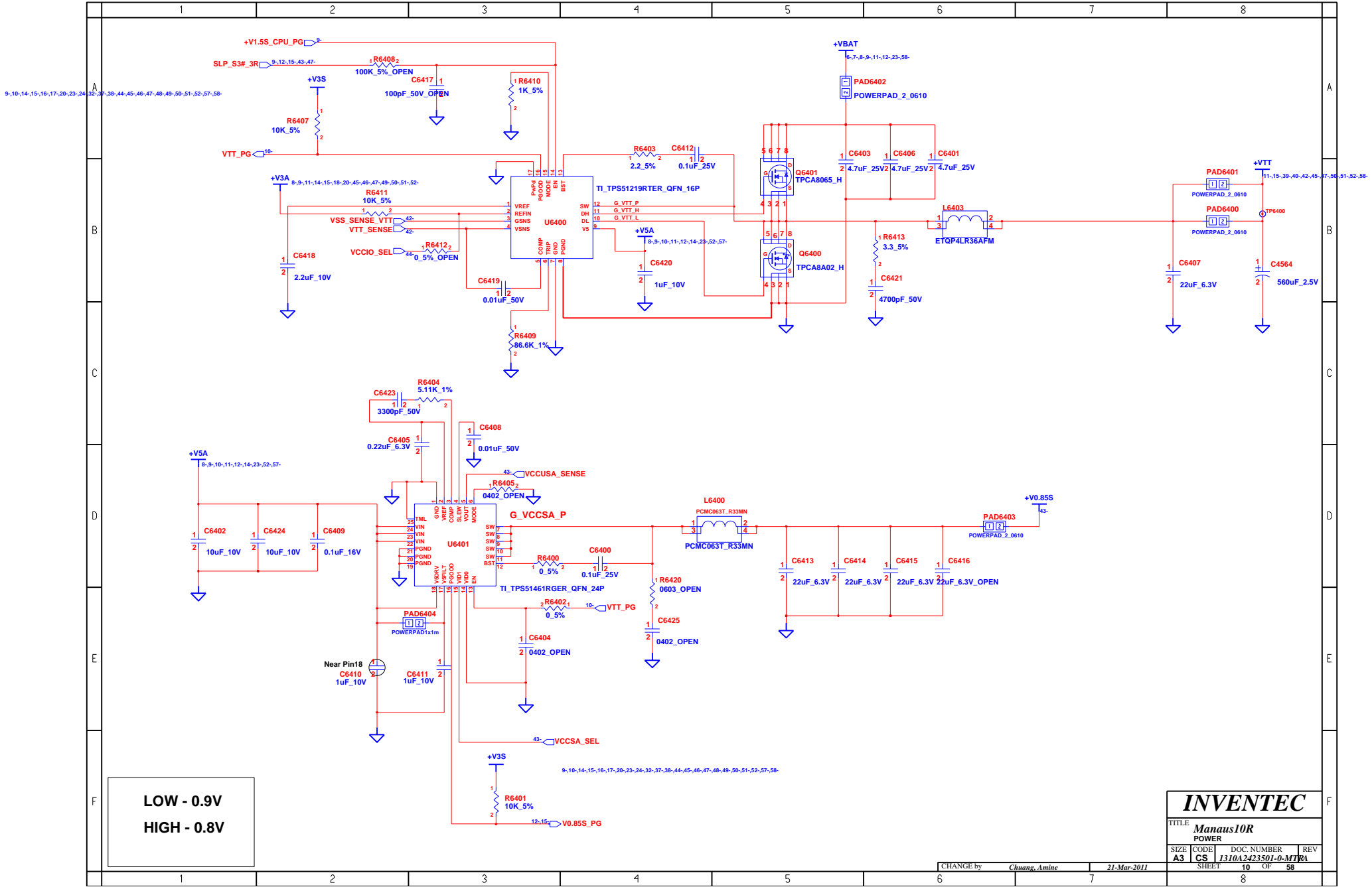

LOW - 0.9V
HIGH - 0.8V

INVENTEC			
TITLE Manaus10R			
POWER			
SIZE A3	CODE CS	DOC. NUMBER 1310A2423501-0-MTR	REV
CHANGE by <i>Chuang, Amine</i>		21-Mar-2011	
SHEET 10		OF 58	

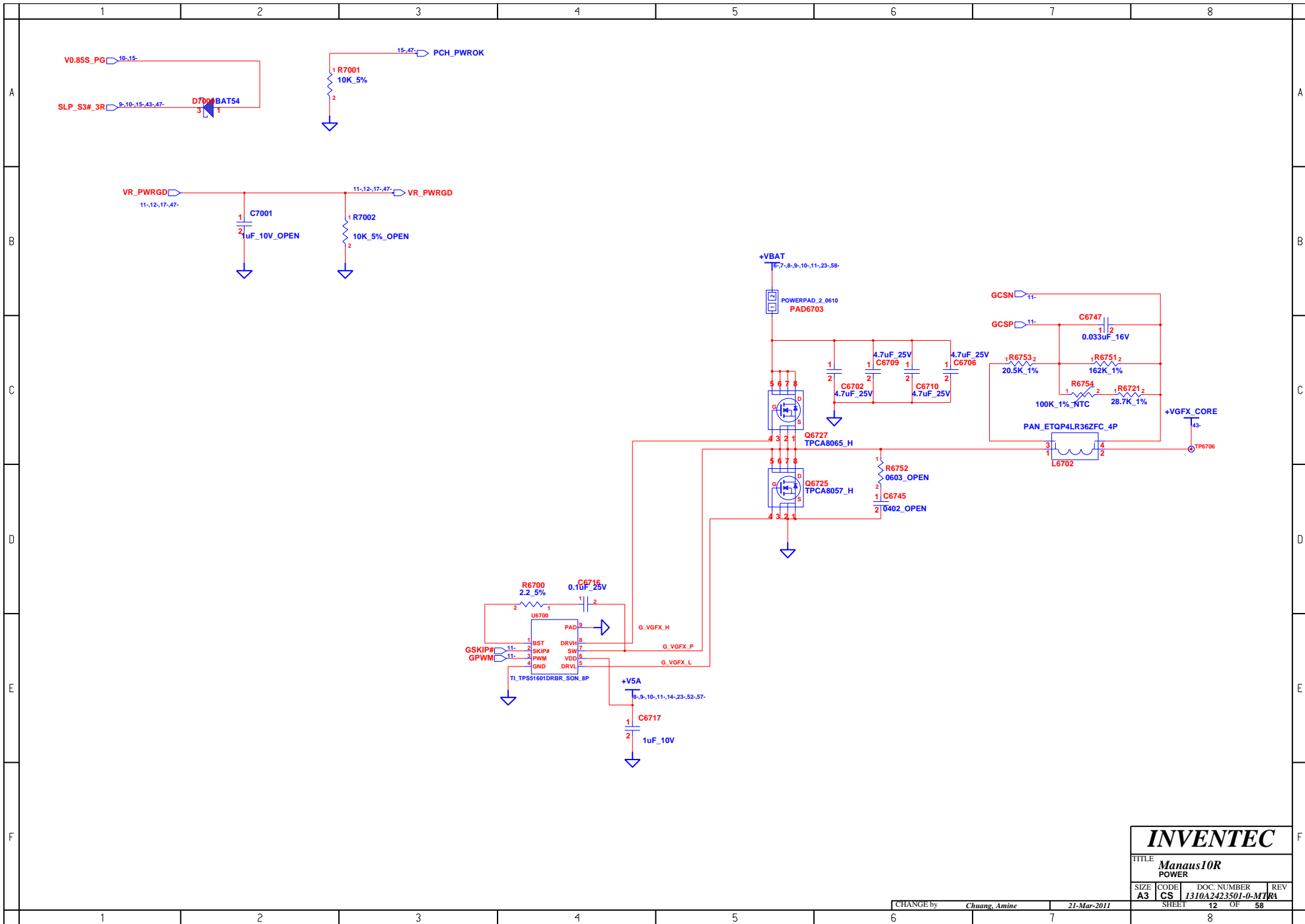

INVENTEC			
TITLE Mana10R POWER			
SIZE A3	CODE CS	DOC. NUMBER 1310A2423501-0-M1	REV KA
CHANGE by <i>Chuang, Amine</i>		21-Mar-2011	
SHEET 12		OF 58	

SKIP

INVENTEC			
TITLE Manaus10R			
SIZE	CODE	DOC. NUMBER	REV
A3	CS	1310A2423501-0-MT	RA
CHANGE by Chuang, Amine		21-Mar-2011	
SHEET		13	OF 58

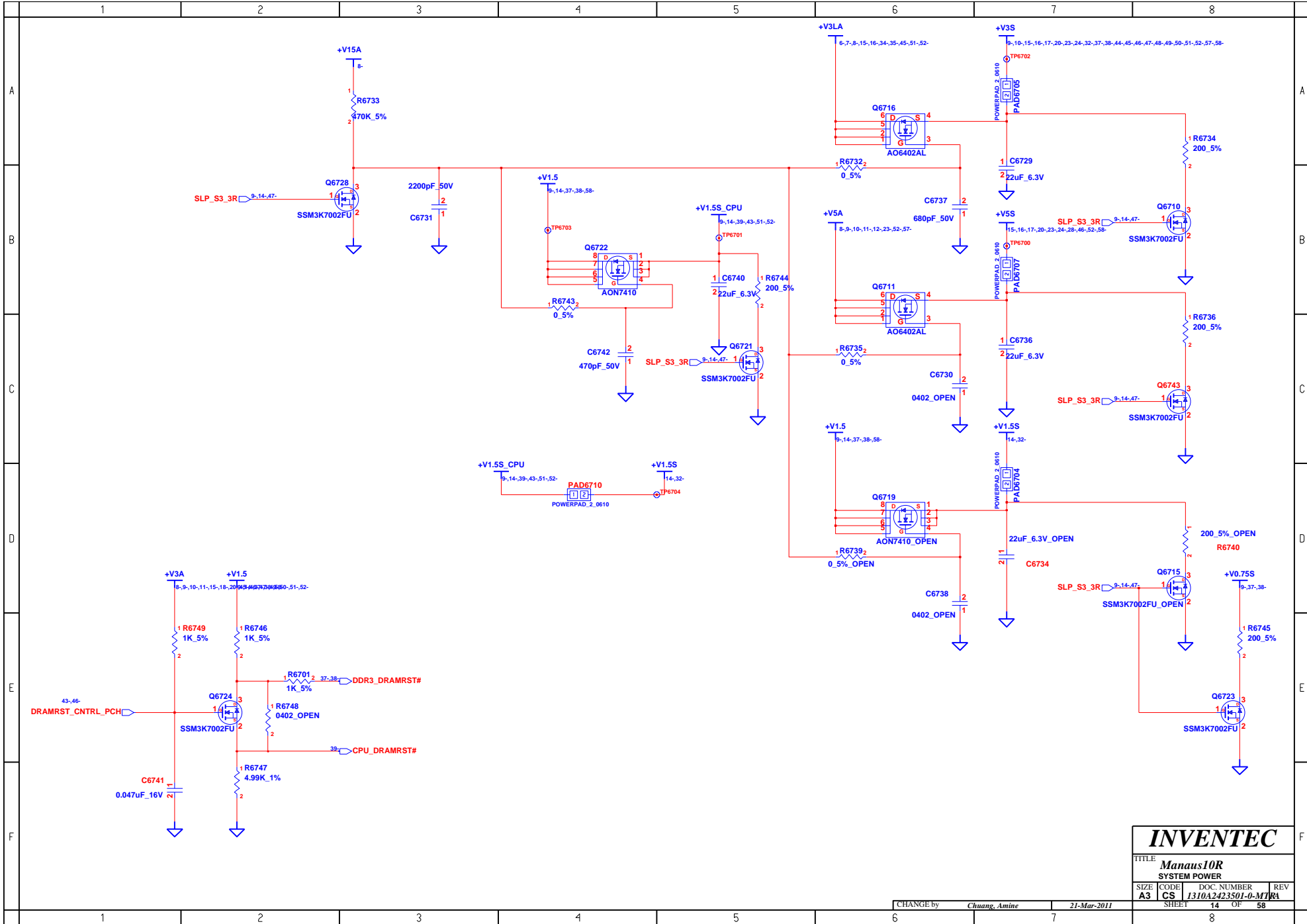

INVENTEC			
TITLE Mana10R			
SYSTEM POWER			
SIZE A3	CODE CS	DOC NUMBER 1310A2423501-0-M1	REV KA
CHANGE by <i>Chuang, Amine</i>		21-Mar-2011	
SHEET 14		OF 58	

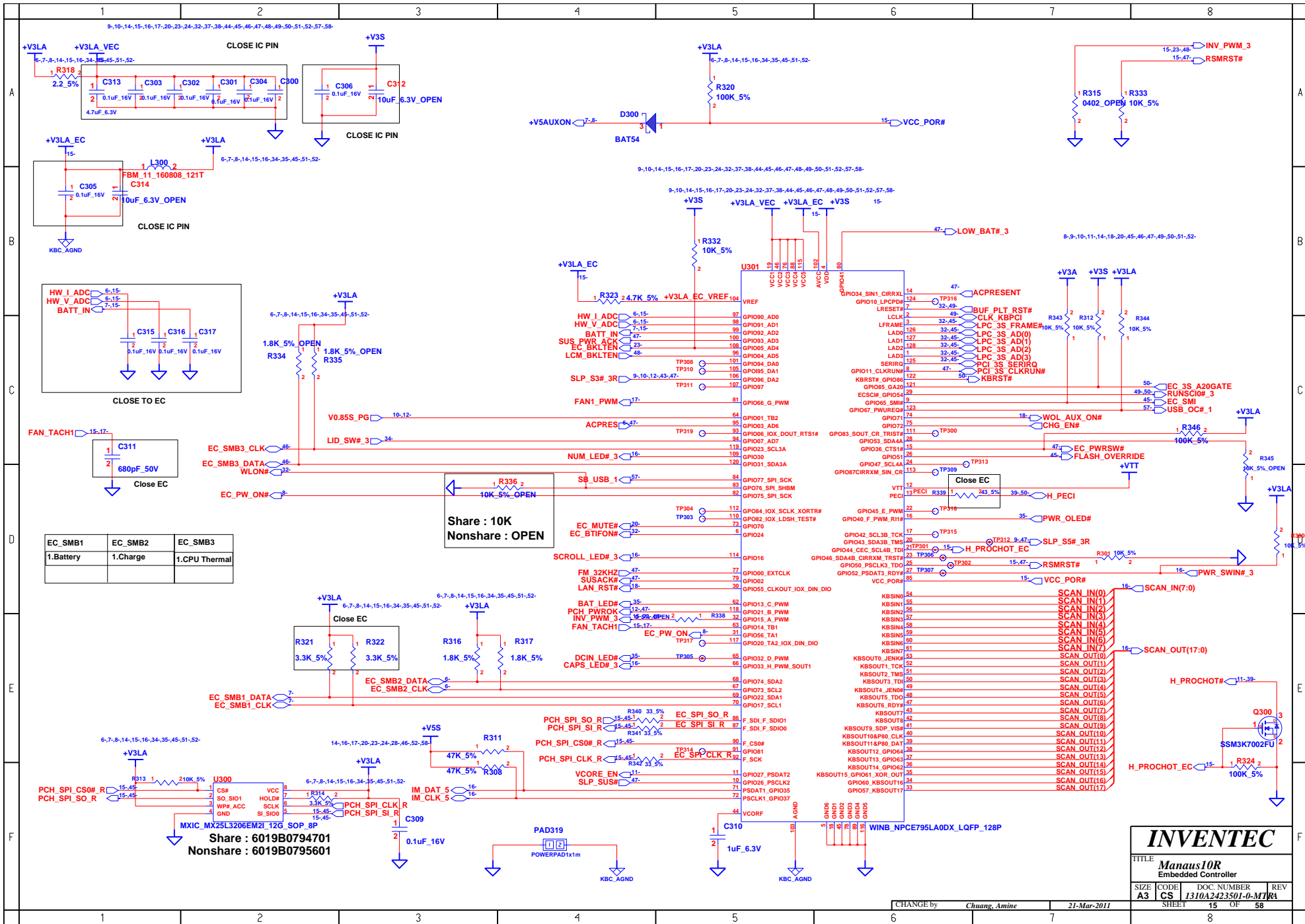

INVENTEC

TITLE: Manaus10R Embedded Controller

SIZE	CODE	DOC NUMBER	REV
A3	CS	1310A2423501-0-MT	KA

CHANGE by: Chuang, Amine 21-Mar-2011

SHEET 15 OF 58

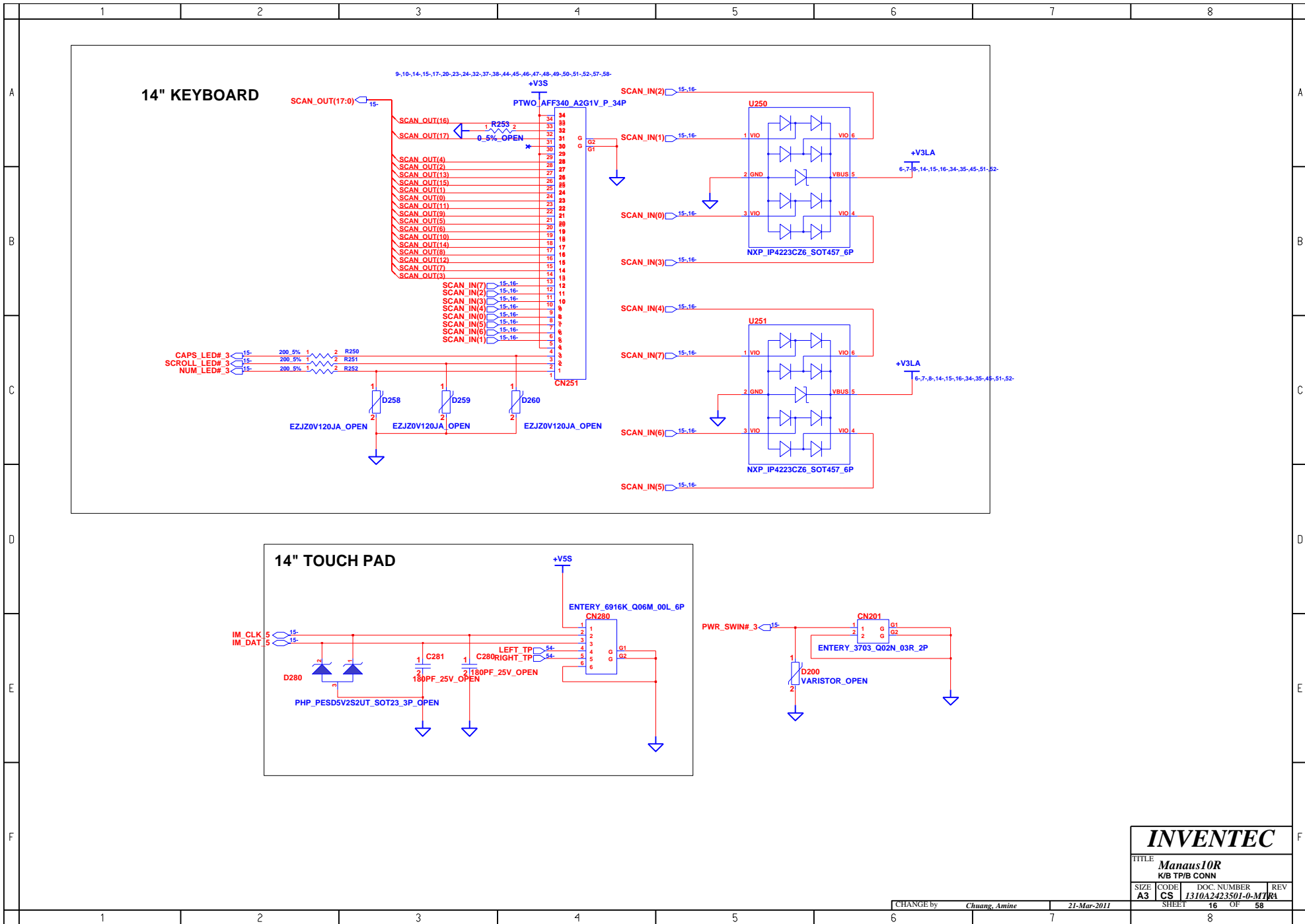

INVENTEC			
TITLE: Manaus10R			
K/B TP/B CONN			
SIZE	CODE	DOC. NUMBER	REV
A3	CS	1310A2423501-0-M1	KA
CHANGE by		21-Mar-2011	SHEET 16 OF 58
1	2	3	8

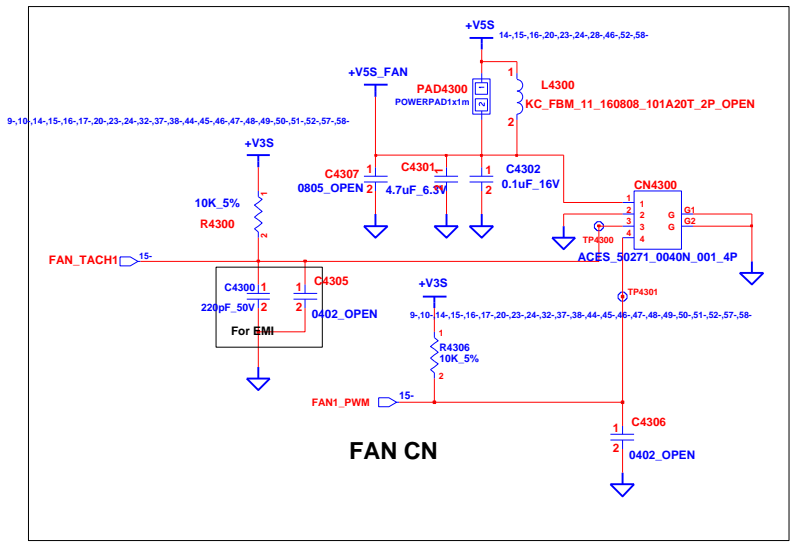

FAN CN

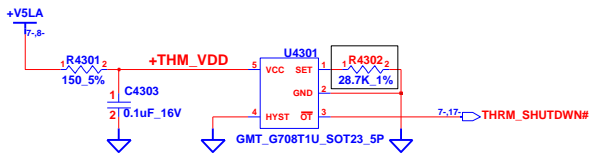
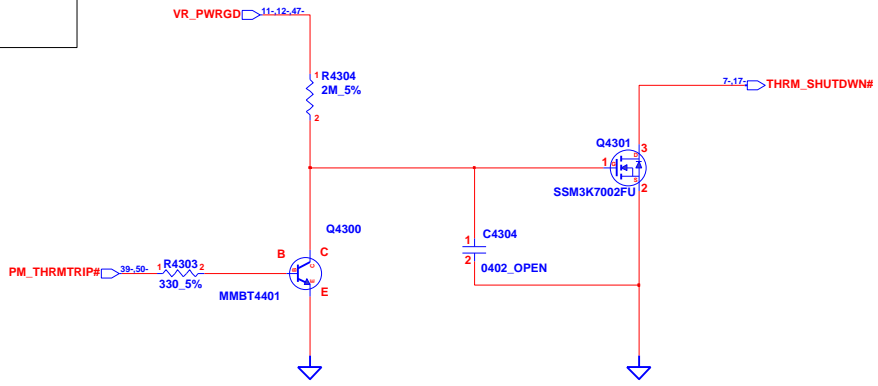

GM Thermal shutdown at 80.9°C +/-3°C from 60°C to 100°C

$$RSET = 0.0012 * T^2 - 0.9308 * T + 96.147$$

Hysteresis is 30C

INVENTEC			
TITLE Manaus10R FAN & THERMAL			
SIZE A3	CODE CS	DOC NUMBER 1310A2423501-0-MT	REV KA
CHANGE by <i>Chuang, Amine</i>		21-Mar-2011	
SHEET 17		OF 58	

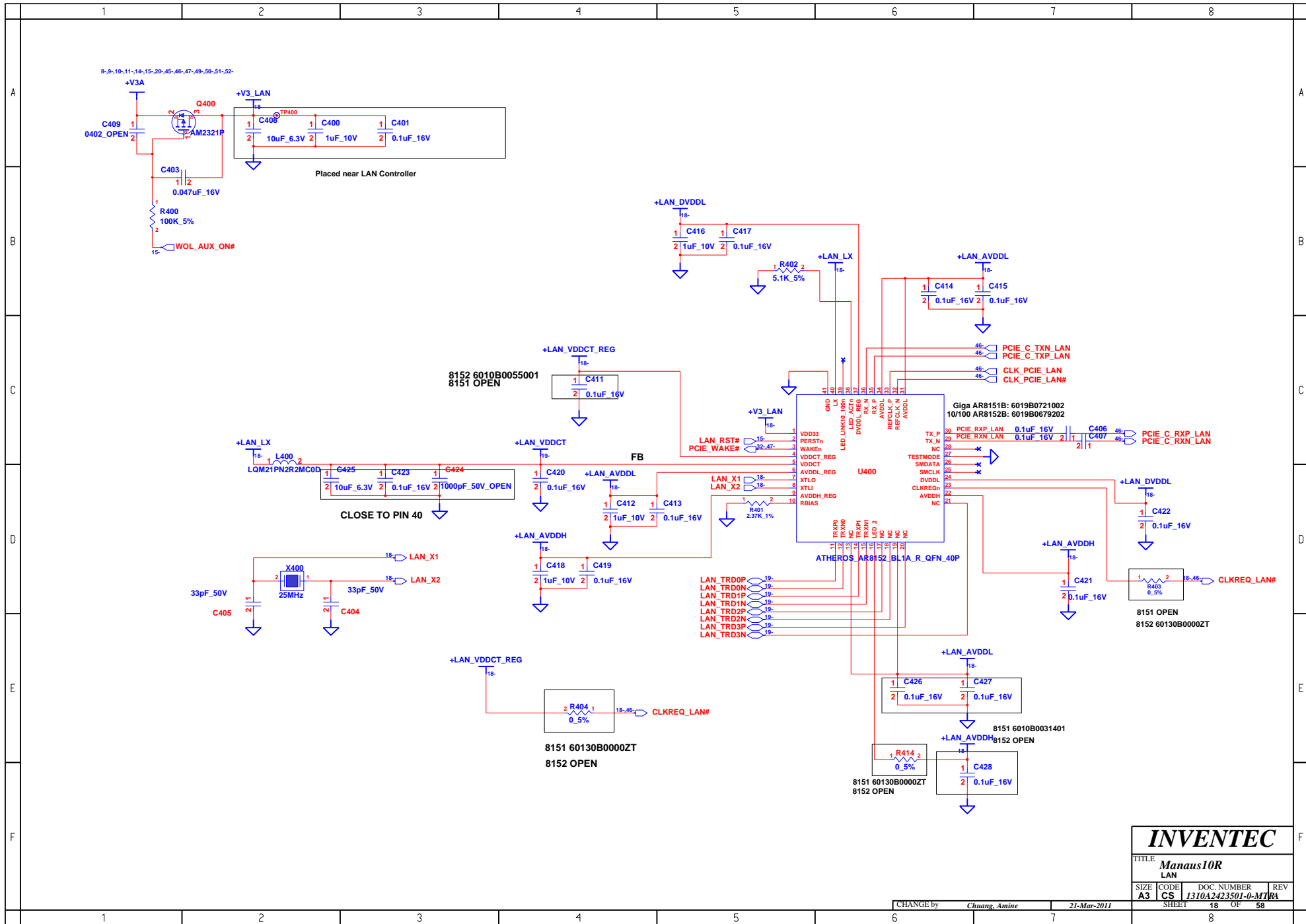

INVENTEC

TITLE			
Mana10R LAN			
SIZE	CODE	DOC. NUMBER	REV
A3	CS	1310A2423501-0-M1	KA
CHANGE by		SHEET	
Chuang, Amine		18 OF 58	

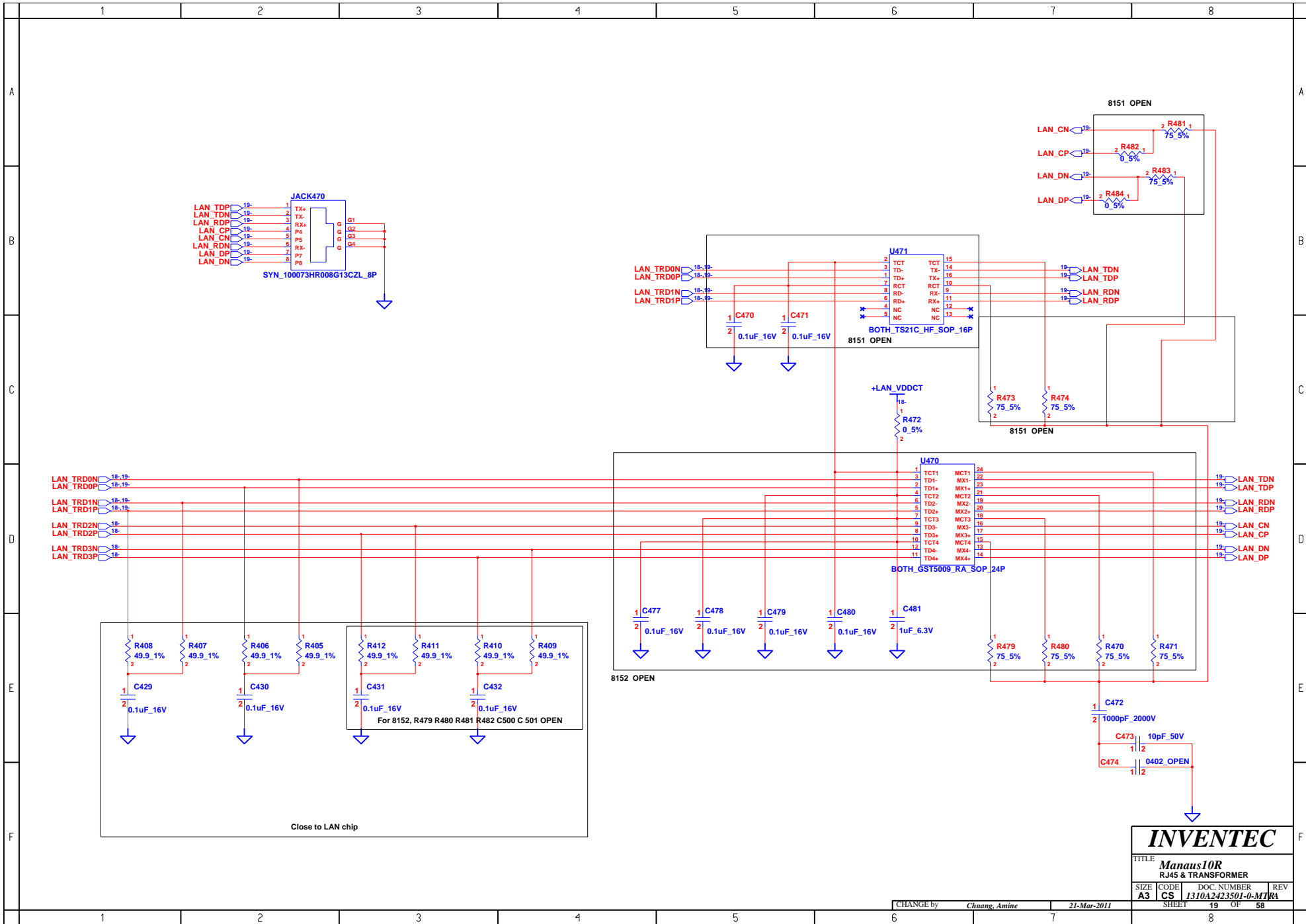

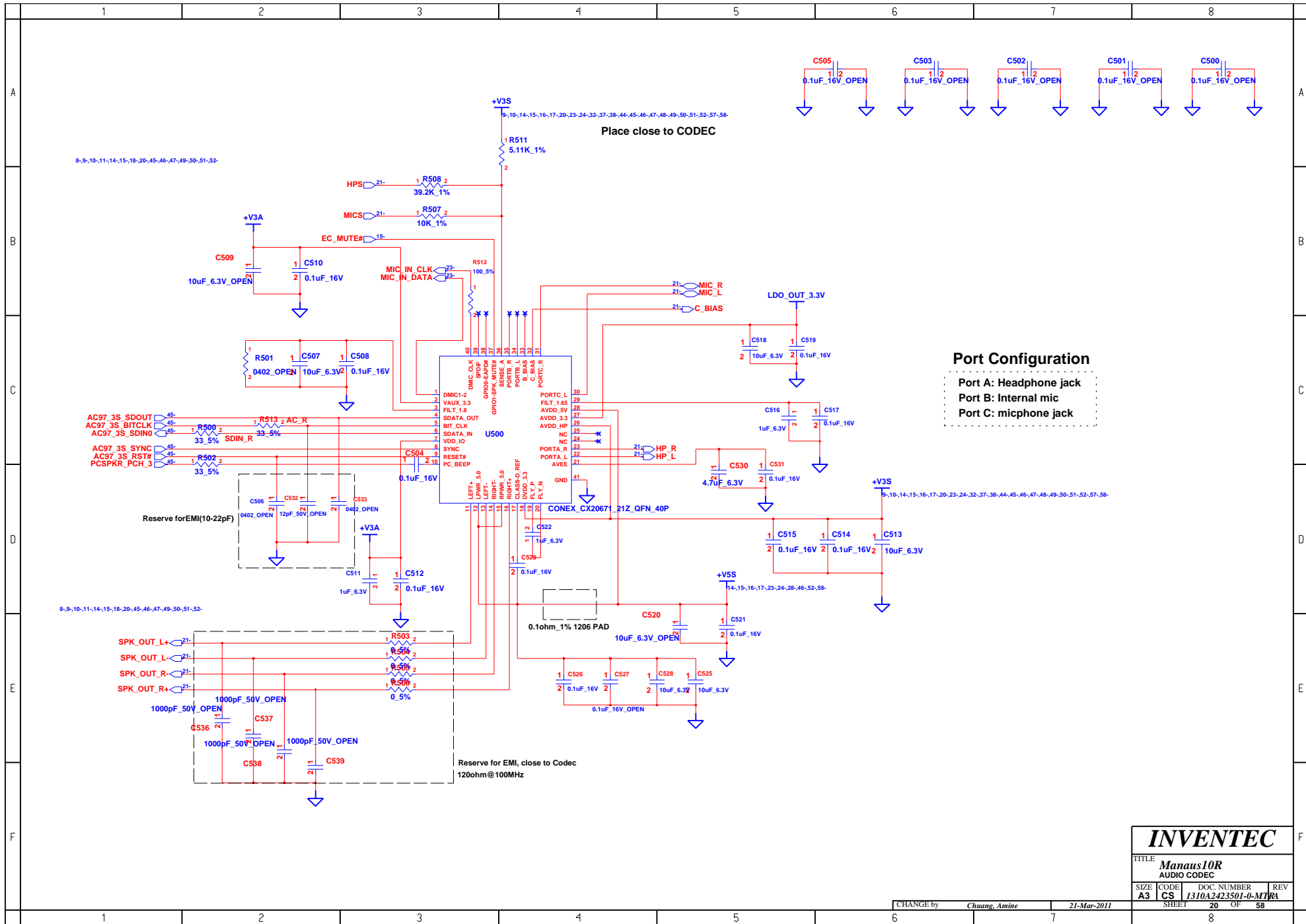

INVENTEC			
TITLE Mana10R AUDIO CODEC			
SIZE A3	CODE CS	DOC. NUMBER 1310A2423501-0-MT	REV KA
CHANGE by <i>Chuang, Amine</i>		21-Mar-2011	
SHEET 20		OF 58	

INTERNAL SPEAKERS

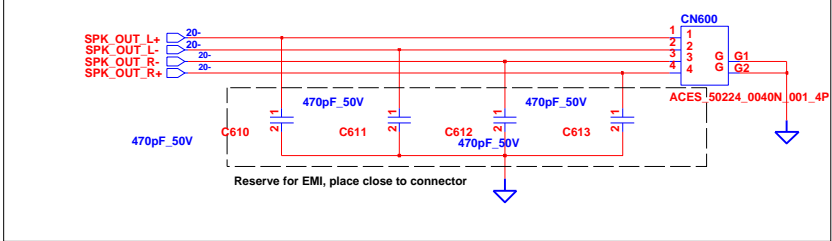

AUDIO JACKS

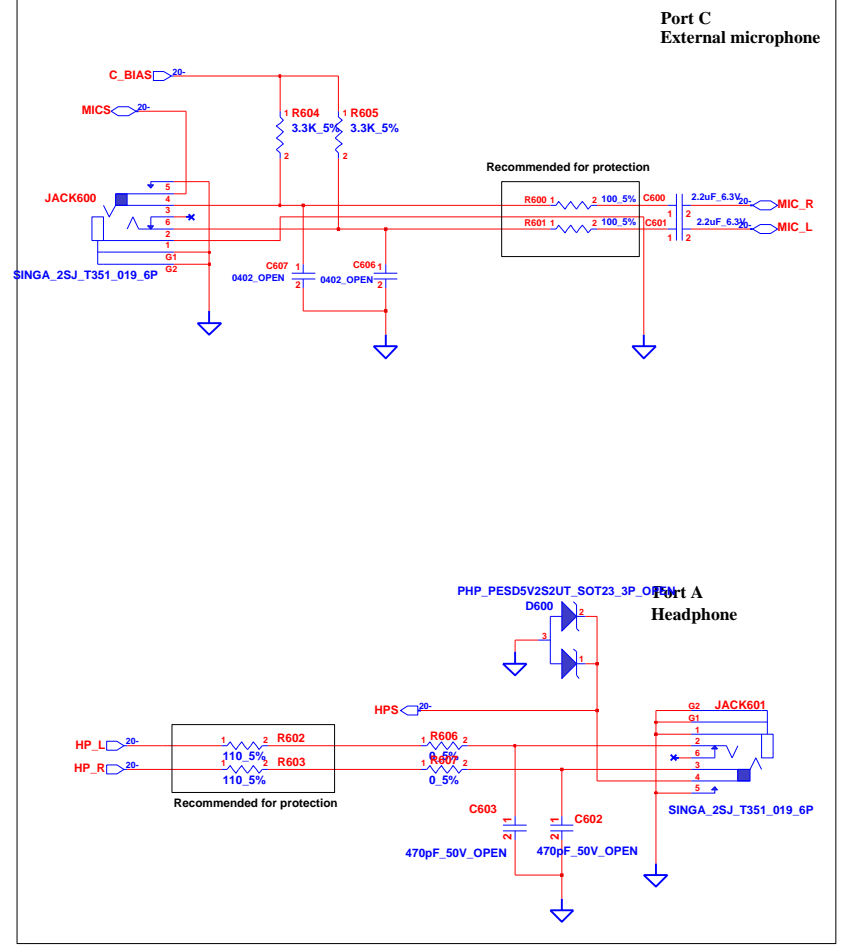

INVENTEC

TITLE			
Manaus10R			
AUDIO JACK & INTERNAL SPEAKER			
SIZE	CODE	DOC NUMBER	REV
A3	CS	1310A2423501-0-M1	KA
SHEET		21 OF 58	

CHANGE by *Chuang, Amine* 21-Mar-2011

SKIP

INVENTEC			
TITLE Manaus10R			
SIZE	CODE	DOC. NUMBER	REV
A3	CS	1310A2423501-0-MT	RA
CHANGE by Chuang, Amine		21-Mar-2011	
SHEET		22	OF 58

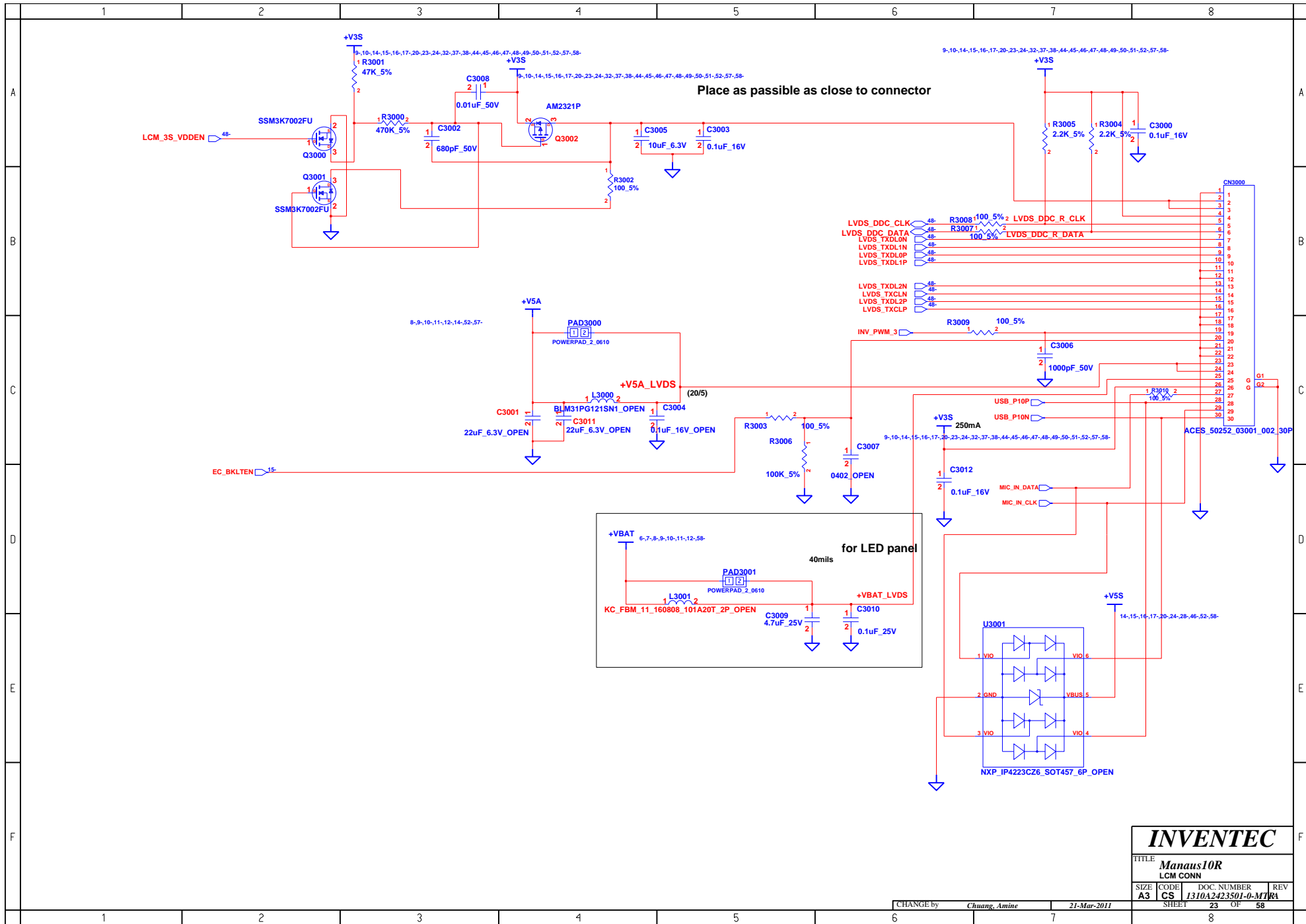

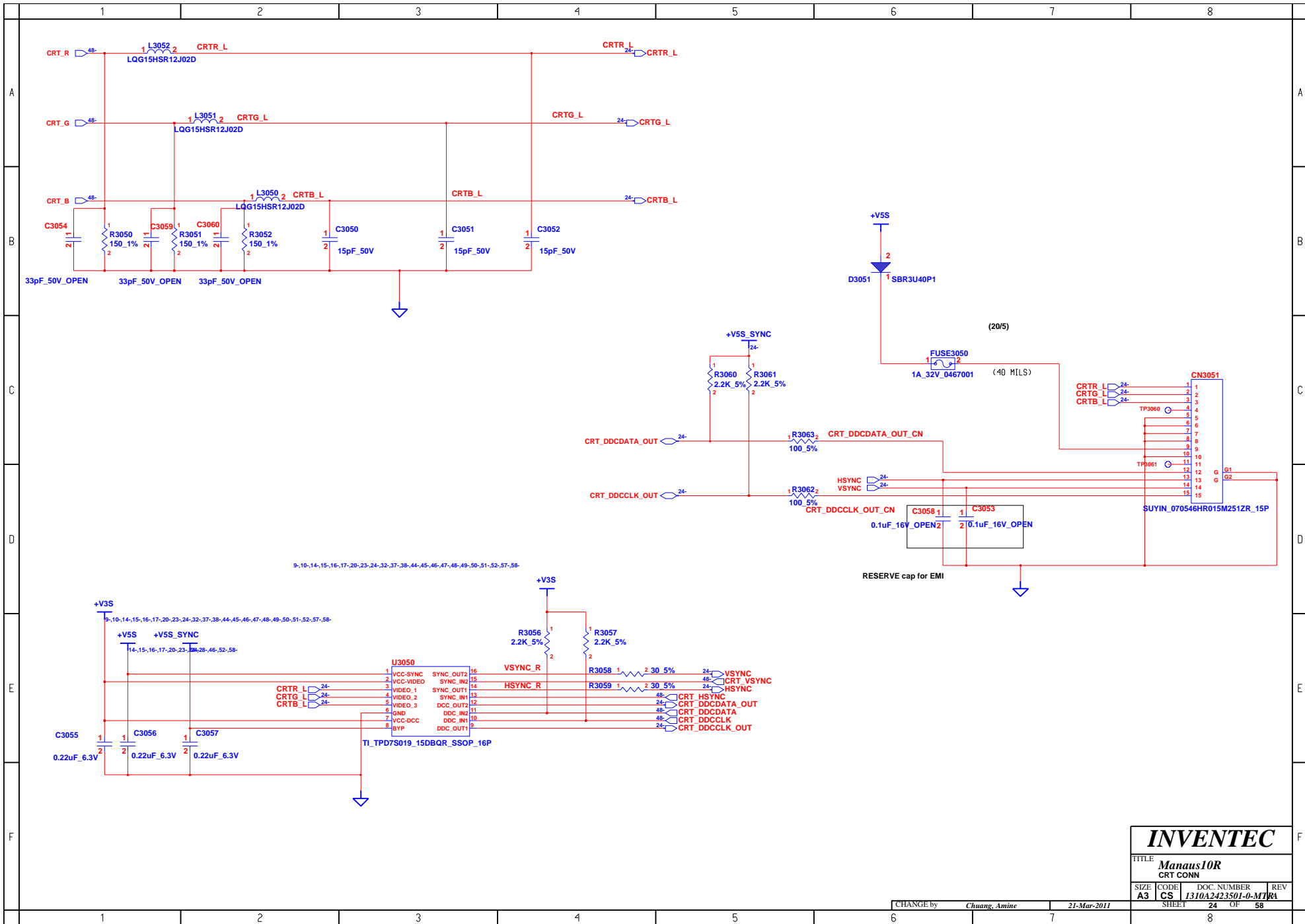

INVENTEC			
TITLE Manaus10R CRT CONN			
SIZE A3	CODE CS	DOC. NUMBER 1310A2423501-0-MT	REV KA
CHANGE by <i>Chuang, Amine</i>		21-Mar-2011	
SHEET 24		OF 58	

	1	2	3	4	5	6	7	8	
A	<h1>SKIP</h1>								A
B									
C									
D									
E									
F									
	1	2	3	4	5	6	7	8	

INVENTEC			
TITLE <i>Manaus10R</i>			
SIZE	CODE	DOC. NUMBER	REV
A3	CS	1310A2423501-0-MT	RA
CHANGE by		21-Mar-2011	
SHEET		25 OF 58	

SKIP

INVENTEC			
TITLE Manaus10R			
SIZE	CODE	DOC. NUMBER	REV
A3	CS	1310A2423501-0-MT	RA
CHANGE by Chuang, Amine		21-Mar-2011	
SHEET 26		OF 58	

SKIP

INVENTEC			
TITLE Manaus10R			
SIZE	CODE	DOC. NUMBER	REV
A3	CS	1310A2423501-0-MT	KA
CHANGE by		21-Mar-2011	
SHEET		OF	
27		58	

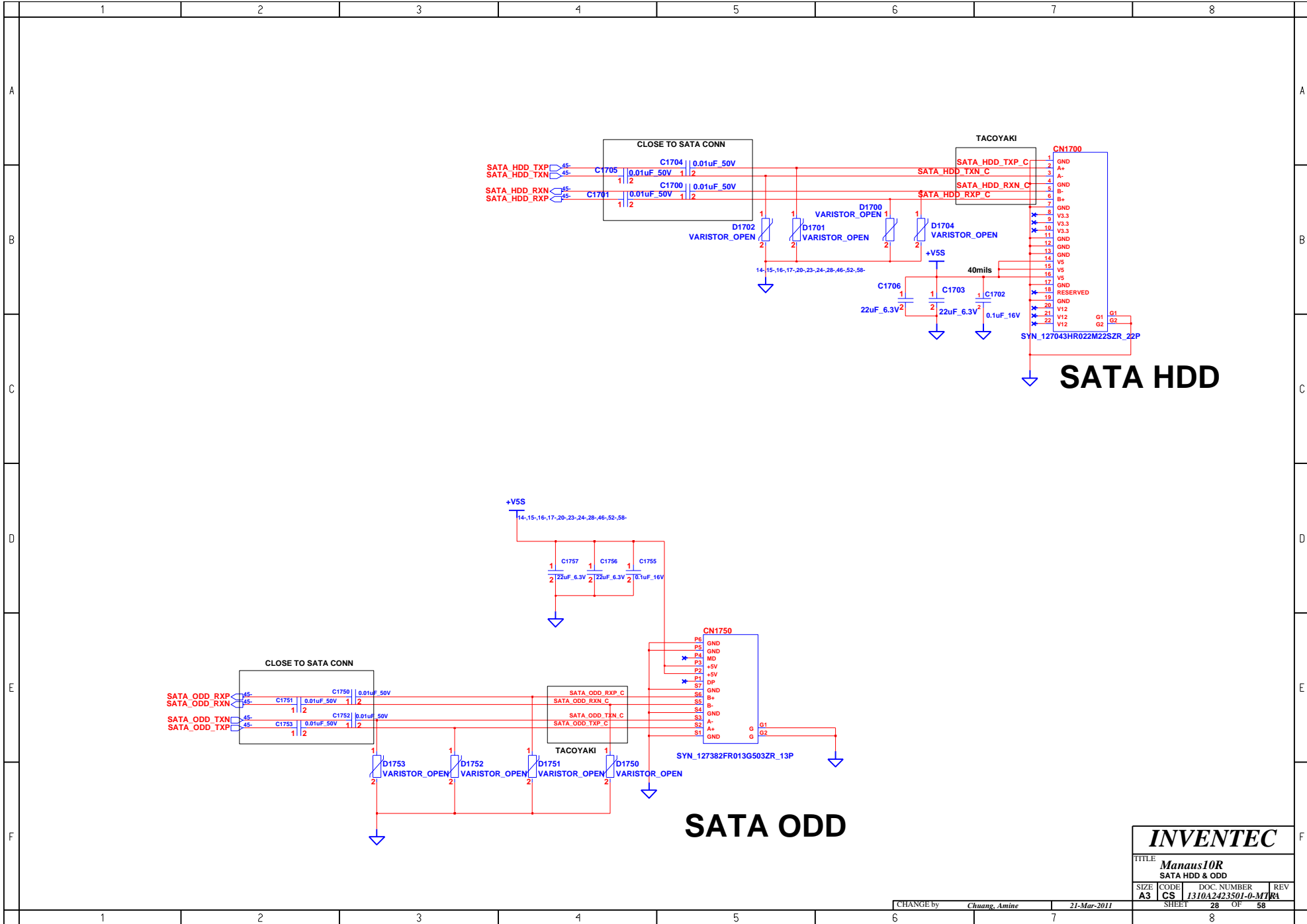

INVENTEC

TITLE			
Manaus10R			
SATA HDD & ODD			
SIZE	CODE	DOC. NUMBER	REV
A3	CS	1310A2423501-0-M1	KA
CHANGE by		SHEET	OF
Chuang, Amine		28	58

SKIP

INVENTEC			
TITLE Manaus10R			
SIZE	CODE	DOC. NUMBER	REV
A3	CS	1310A2423501-0-MT	RA
CHANGE by		21-Mar-2011	
SHEET		OF	
29		58	

SKIP

INVENTEC			
TITLE Manaus10R			
SIZE	CODE	DOC. NUMBER	REV
A3	CS	1310A2423501-0-MT	KA
CHANGE by Chuang, Amine		21-Mar-2011	
SHEET 30		OF 58	

SKIP

INVENTEC			
TITLE Manaus10R			
SIZE	CODE	DOC. NUMBER	REV
A3	CS	1310A2423501-0-MT	RA
CHANGE by Chuang, Amine		21-Mar-2011	
SHEET 31		OF 58	

Wireless & Debug card

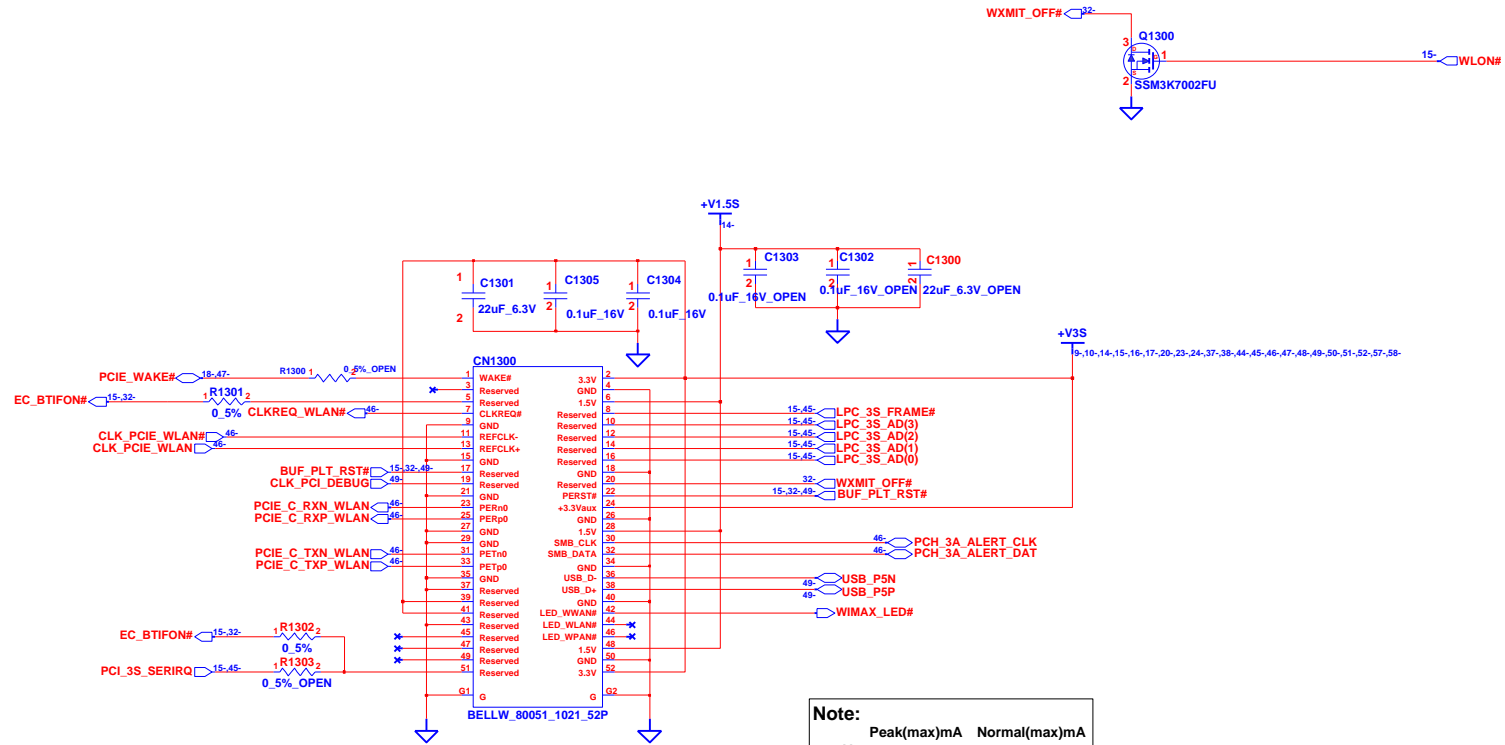

MINI CARD 1

INVENTEC

TITLE			
Manaus10R WLAN/DEBUG CARD			
SIZE	CODE	DOC. NUMBER	REV
A3	CS	1310A2423501-0-M1	KA
SHEET		32	OF 58

CHANGE by Chuang, Amine 21-Mar-2011

SKIP

INVENTEC

TITLE
Manaus10R

SIZE	CODE	DOC. NUMBER	REV
A3	CS	1310A2423501-0-MT	RA

SHEET 33 OF 58

CHANGE by *Chuang, Amine* 21-Mar-2011

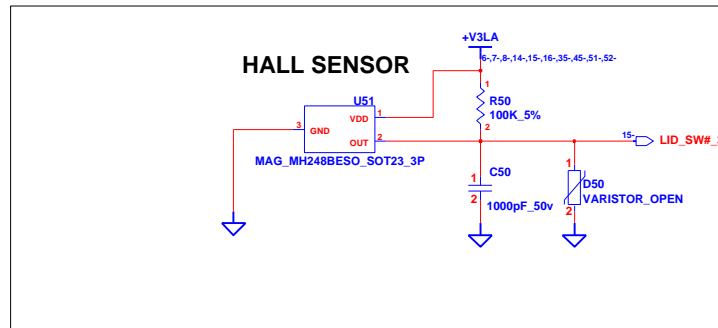

INVENTEC			
TITLE			
<i>Manaus10R</i> HALL SENSOR			
SIZE	CODE	DOC. NUMBER	REV
A3	CS	1310A2423501-0-MJ	KA
CHANGE by		SHEET	
Chuang, Amine		34 OF 58	
		21-Mar-2011	

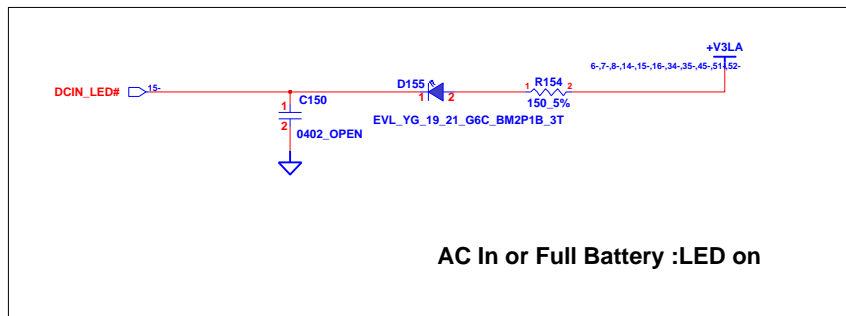
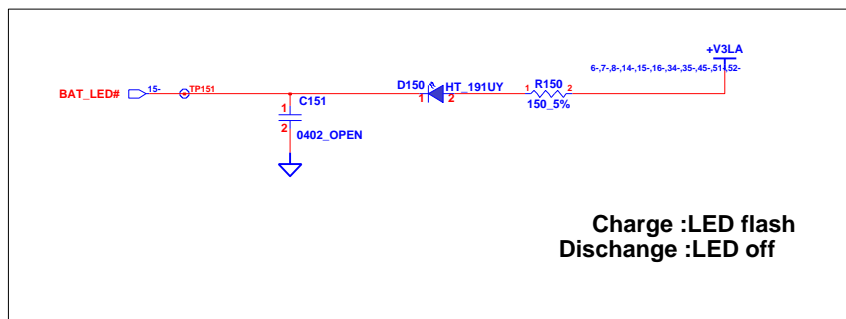
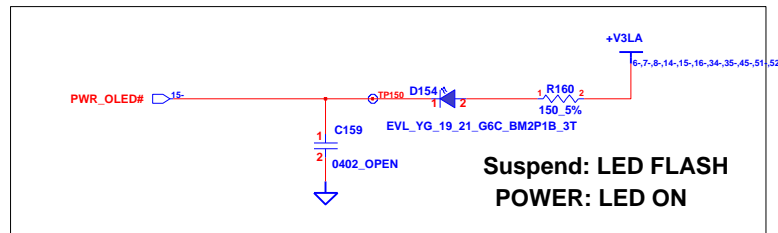

INVENTEC			
TITLE Manaus10R			
LED			
SIZE A3	CODE CS	DOC. NUMBER 1310A2423501-0-MT	REV KA
CHANGE by <i>Chuang, Amine</i>		21-Mar-2011	
SHEET		35 OF 58	

SKIP

INVENTEC			
TITLE Manaus10R			
SIZE	CODE	DOC. NUMBER	REV
A3	CS	1310A2423501-0-MT	KA
CHANGE by		21-Mar-2011	
SHEET		36 OF 58	

CHA

9,10,14,15,16,17,20,23,24,32,37,38,44,45,46,47,48,49,50,51,52,57,58-

Layout NOTE: Place these Caps near SO-DIMM0 power pin

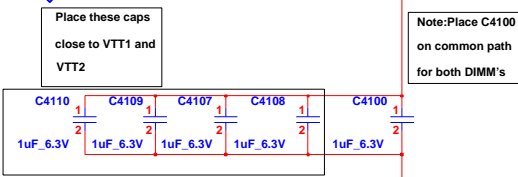
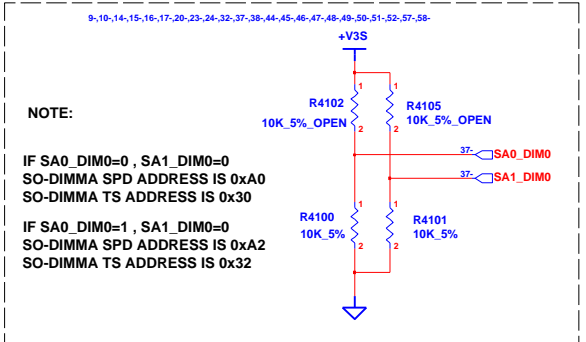
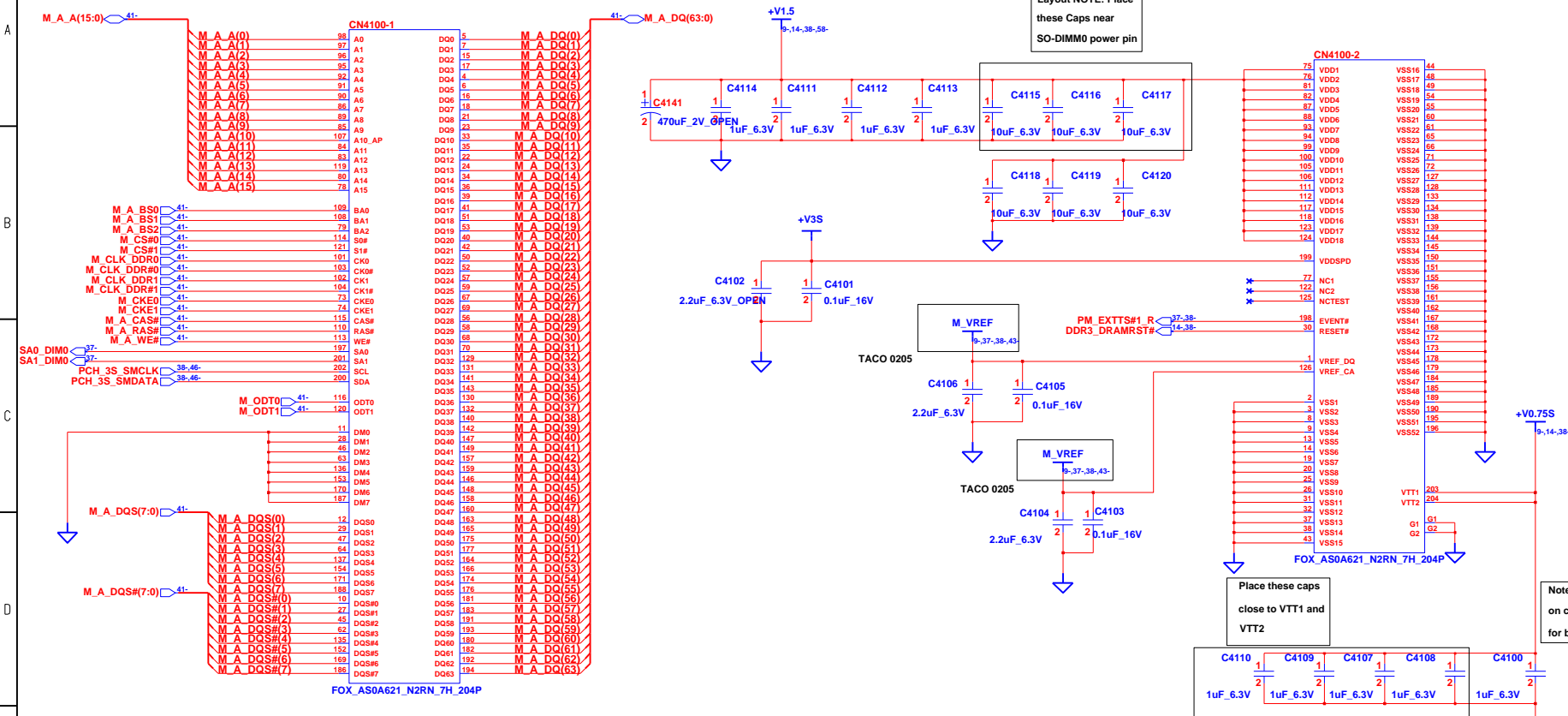

INVENTEC			
TITLE: Manaus10R			
DDR3 DIMM0			
SIZE	CODE	DOC. NUMBER	REV
A3	CS	1310A2423501-0-MT	KA
SHEET		37	OF 58

9,10,14,15,16,17,20,23,24,32,37,38,44,45,46,47,48,49,50,51,52,57,58-

CHANGE by *Chuang, Amine* 21-Mar-2011

CHB

Layout Note: Place these Caps near SO-DIMM1 power pin

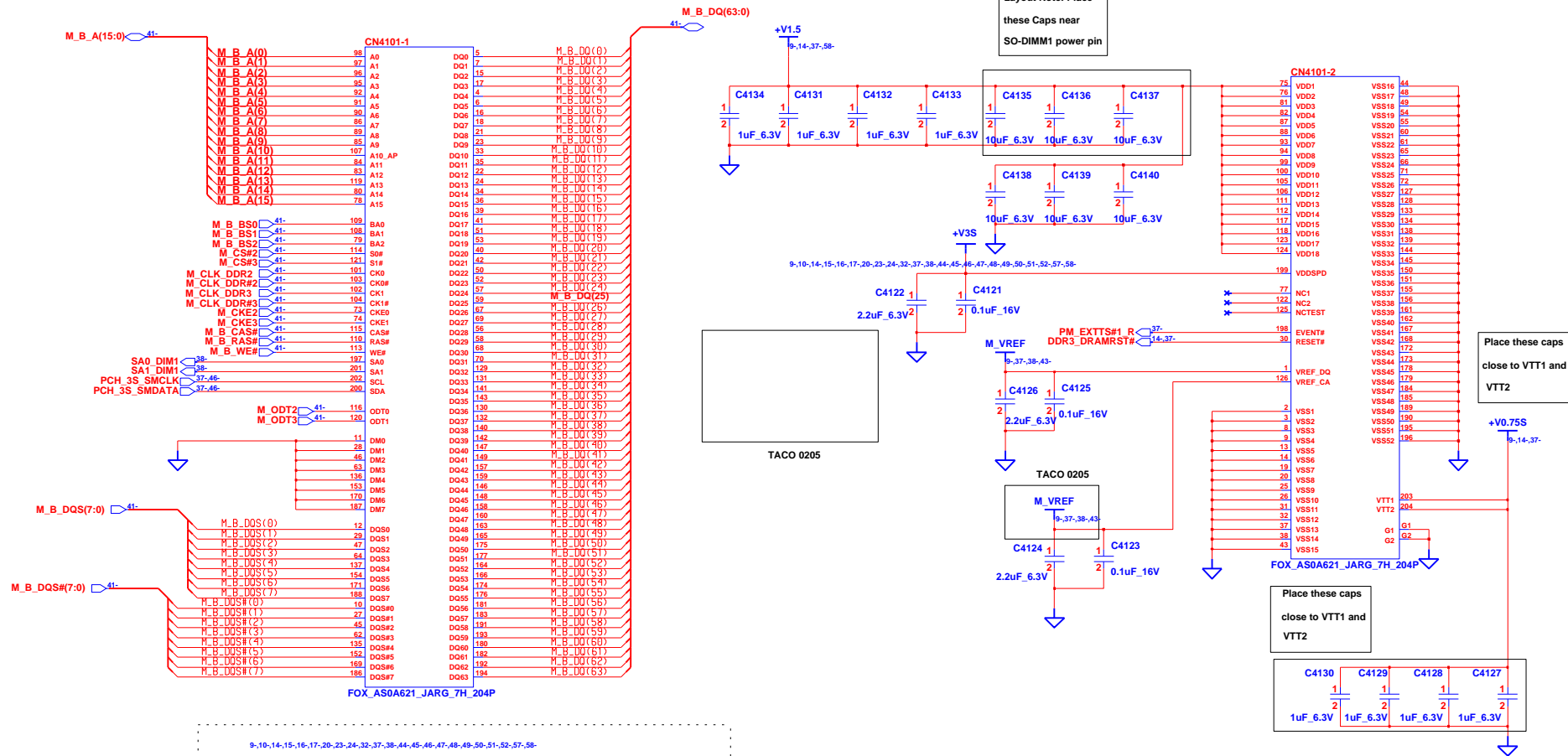

NOTE:
SO-DIMMB SPD ADDRESS IS 0xA4
SO-DIMMB TS ADDRESS IS 0x34

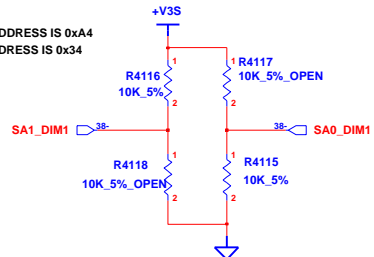

INVENTEC

TITLE: **Manaus10R**
DDR3 DIMM1

SIZE	CODE	DOC. NUMBER	REV
A3	CS	1310A2423501-0-M1	1

SHEET	OF
38	58

CHANGE by *Chuang, Amine* 21-Mar-2011

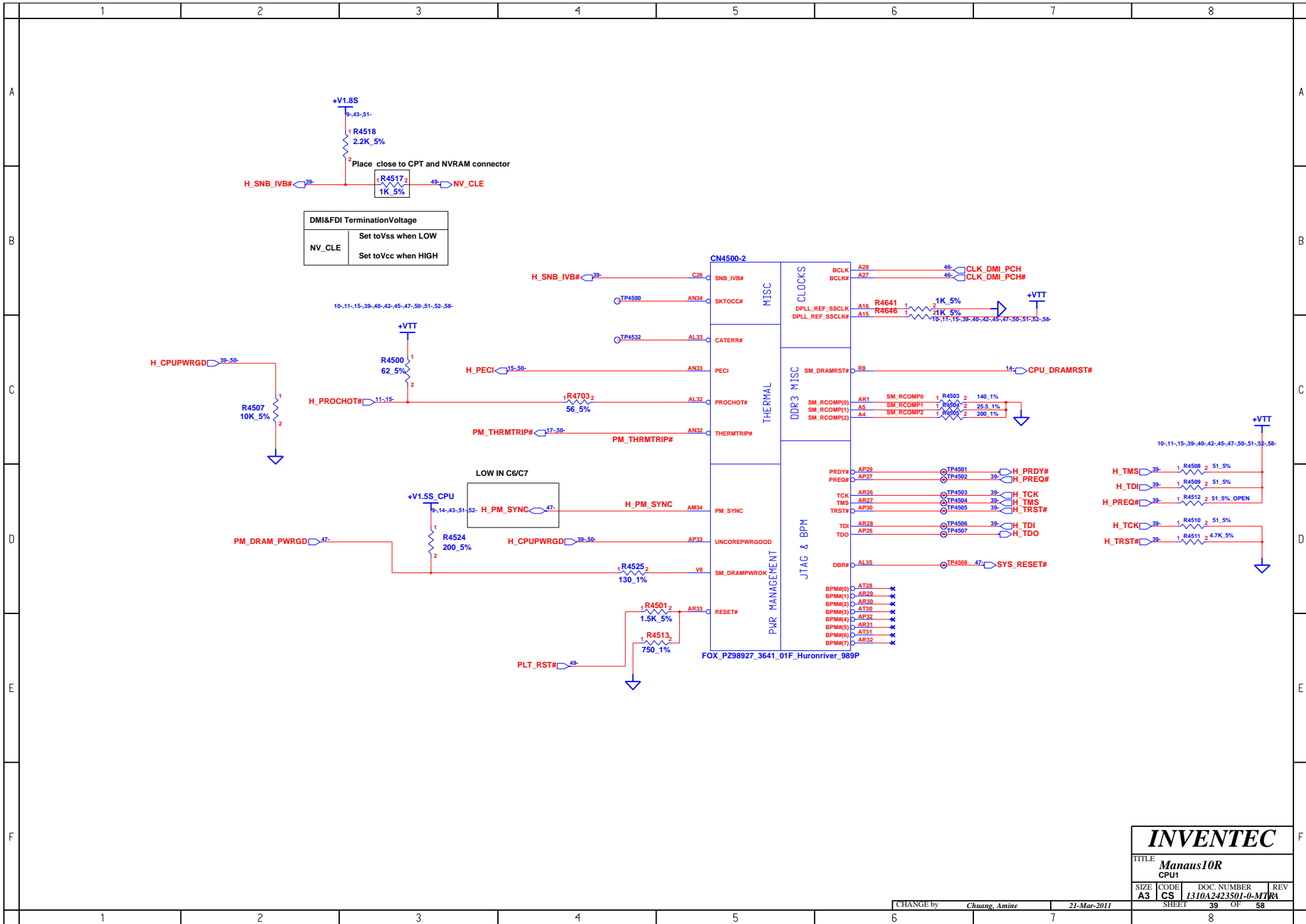

INVENTEC			
TITLE Mana10R			
CPU1			
SIZE A3	CODE CS	DOC. NUMBER 1310A2423501-0-MTR	REV KA
CHANGE by <i>Chuang, Amine</i>		21-Mar-2011	
SHEET 39		OF 58	

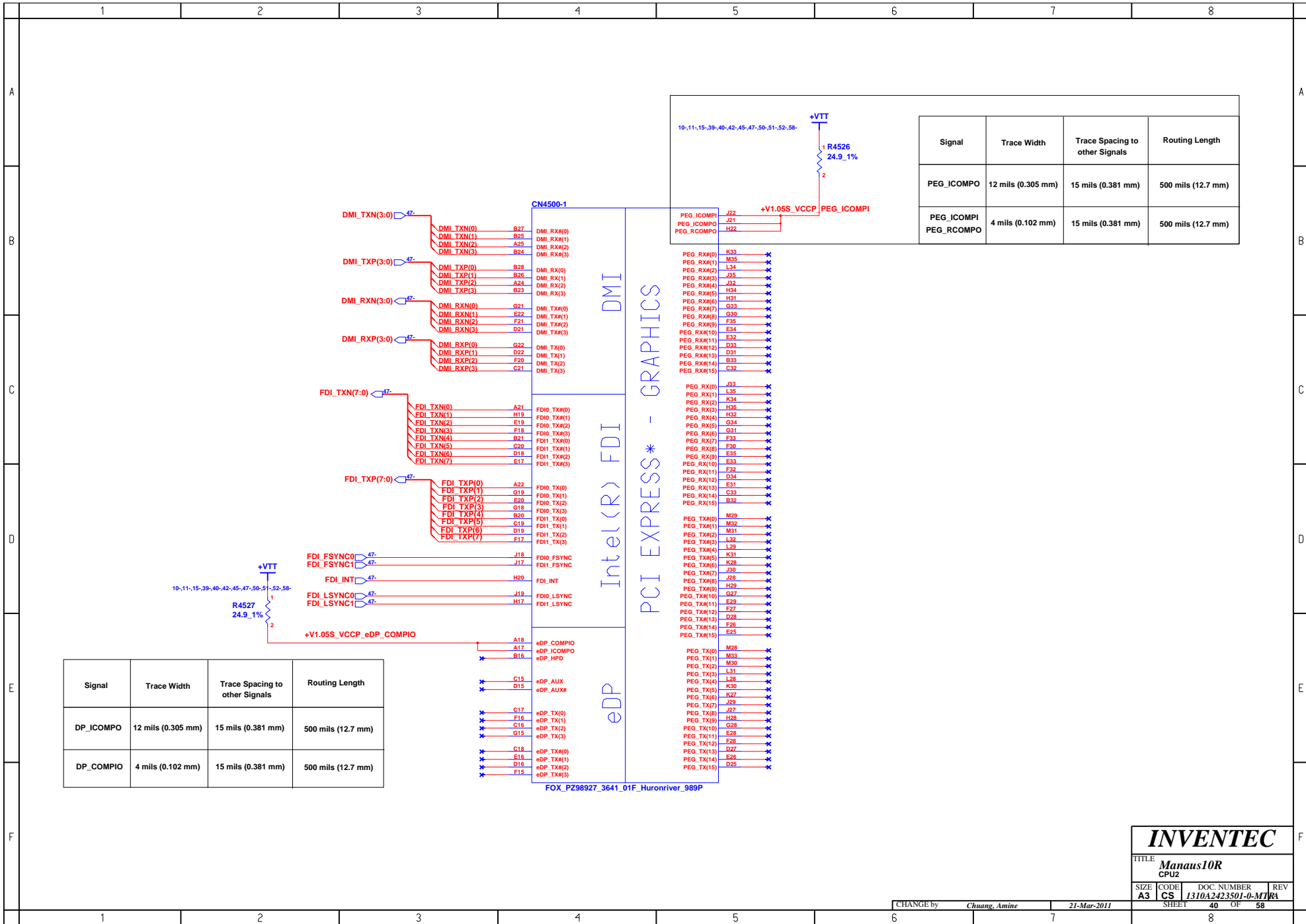

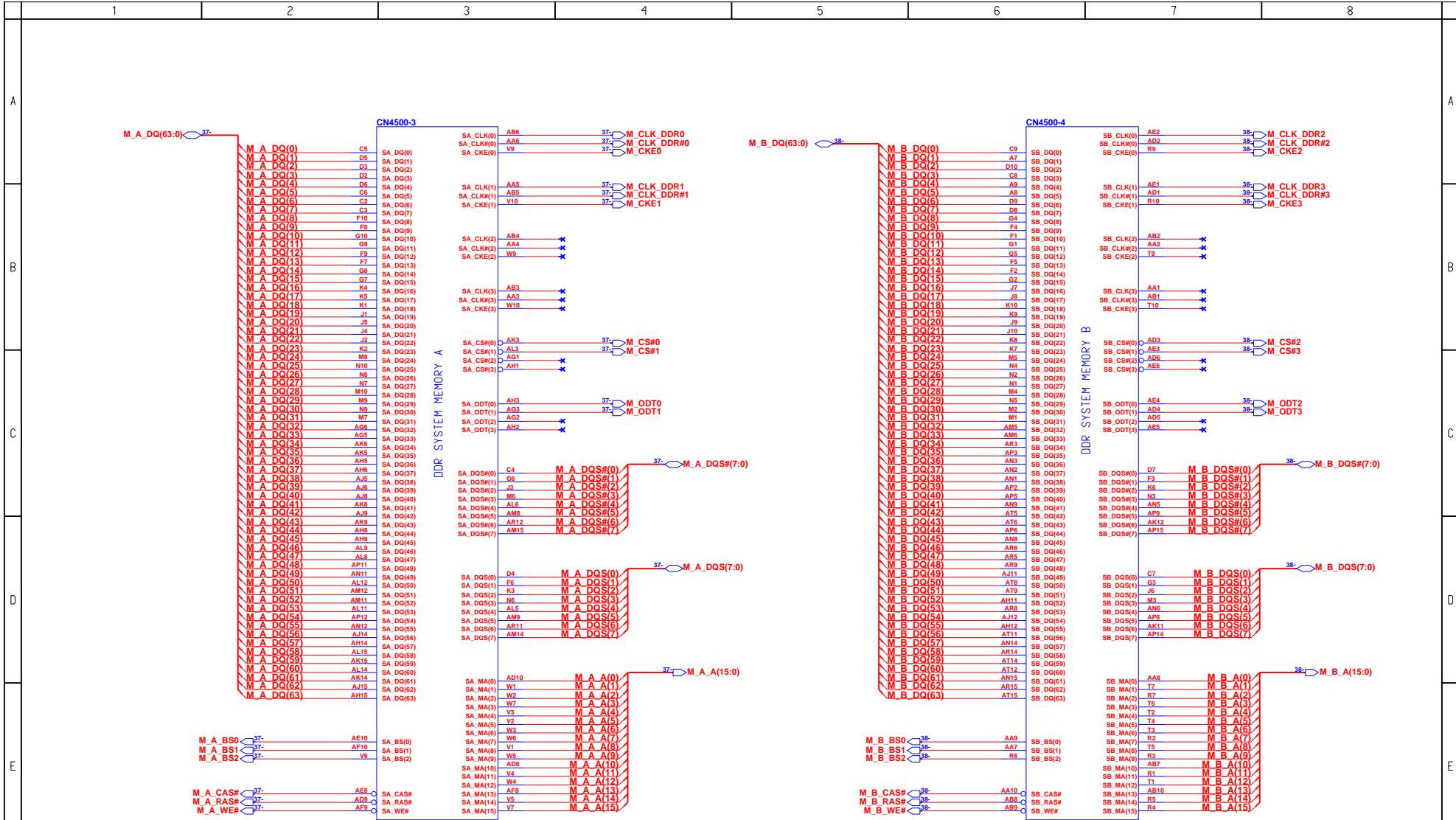

FOX_PZ98927_3641_01F_Huronriver_989P

FOX_PZ98927_3641_01F_Huronriver_989P

INVENTEC			
TITLE Manaus10R			
CPUS			
SIZE	CODE	DOC. NUMBER	REV
A3	CS	1310A2423501-0-M1	R1
CHANGE by		21-Mar-2011	
SHEET		41	OF 58

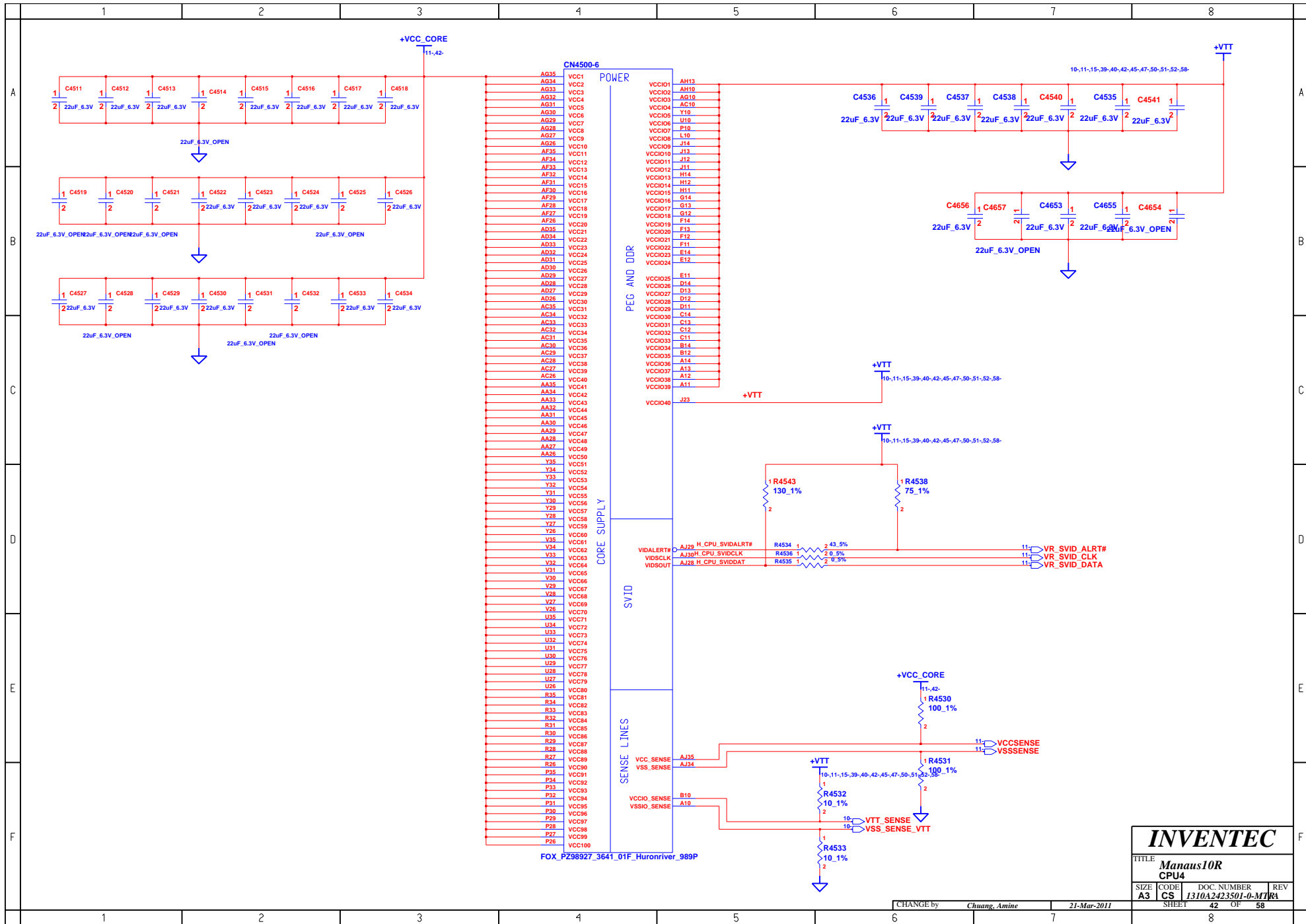

INVENTEC			
TITLE: Manaus10R CPU4			
SIZE: A3	CODE: CS	DOC. NUMBER: 1310A2423501-0-MTR	REV: 1
CHANGE by: Chuang, Amine		21-Mar-2011	
SHEET: 42		OF: 58	

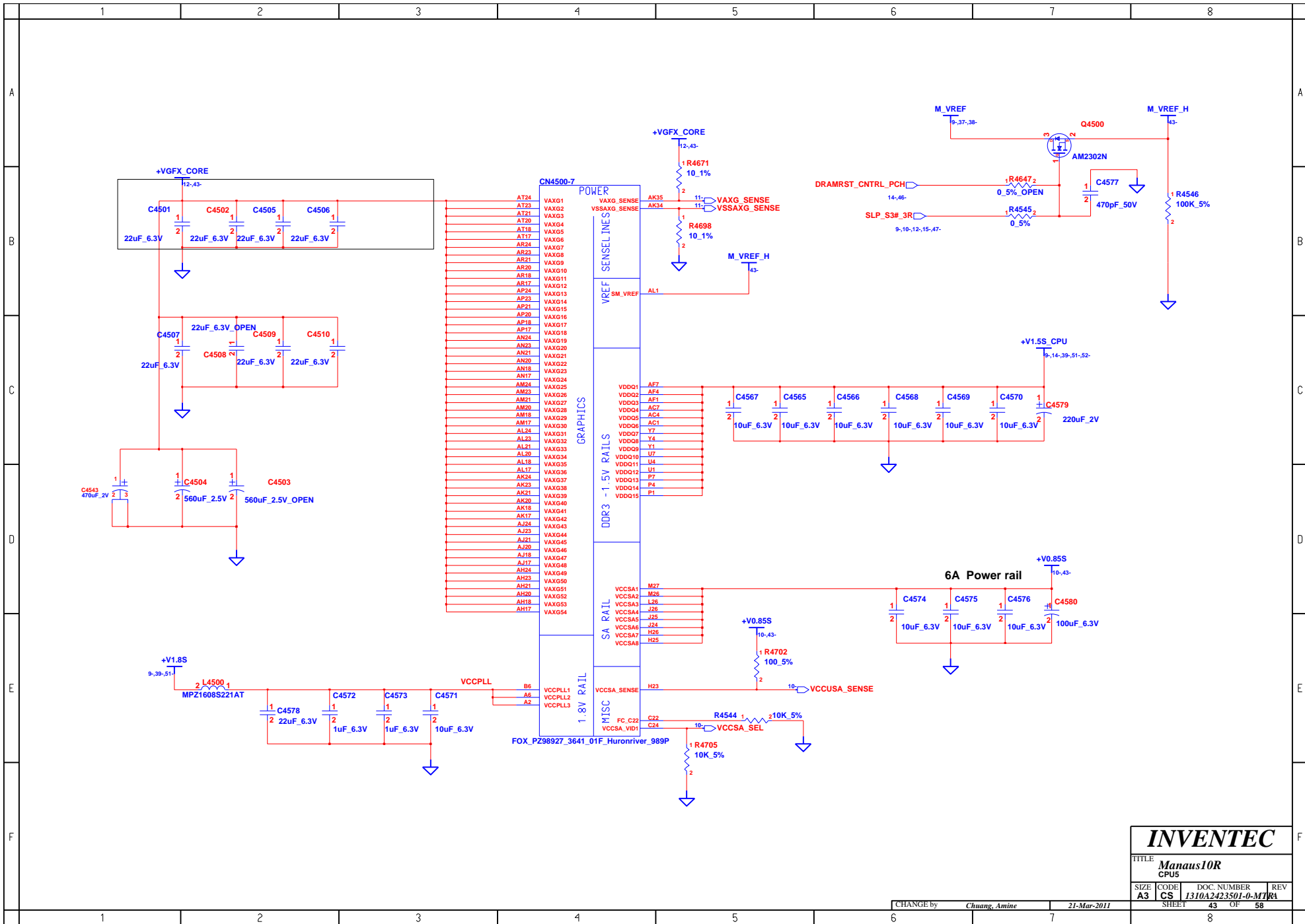

INVENTEC			
TITLE: Mana10R CPU			
SIZE: A3	CODE: CS	DOC. NUMBER: 1310A2423501-0-M1	REV: KA
CHANGE by: <i>Chuang, Amine</i>		21-Mar-2011	
SHEET: 43		OF: 58	

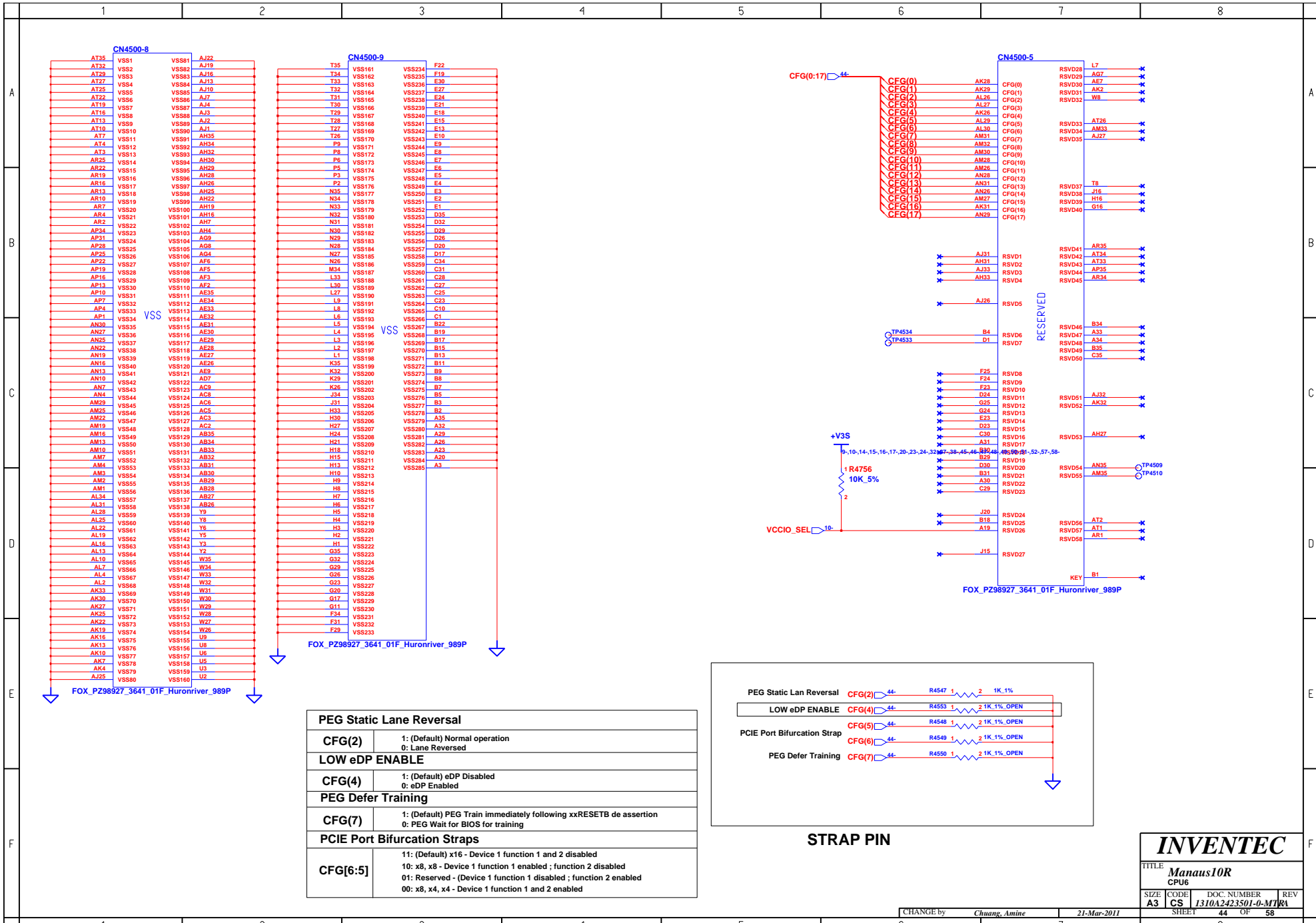

PEG Static Lane Reversal	
CFG(2)	1: (Default) Normal operation 0: Lane Reversed
LOW eDP ENABLE	
CFG(4)	1: (Default) eDP Disabled 0: eDP Enabled
PEG Defer Training	
CFG(7)	1: (Default) PEG Train immediately following xxRESETB de assertion 0: PEG Wait for BIOS for training
PCIe Port Bifurcation Straps	
CFG[6:5]	11: (Default) x16 - Device 1 function 1 and 2 disabled 10: x8, x8 - Device 1 function 1 enabled ; function 2 disabled 01: Reserved - (Device 1 function 1 disabled ; function 2 enabled) 00: x8, x4, x4 - Device 1 function 1 and 2 enabled

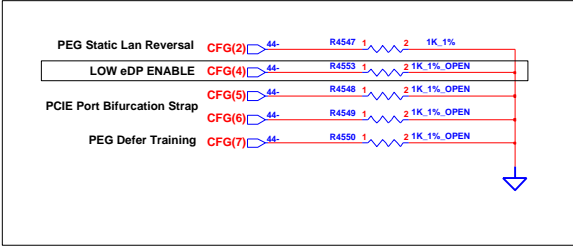

INVENTEC			
TITLE Manaus10R CPU6			
SIZE A3	CODE CS	DOC. NUMBER 1310A2423501-0-M1	REV 1
CHANGE by <i>Chuang, Amine</i>		21-Mar-2011	
SHEET 44		OF 58	

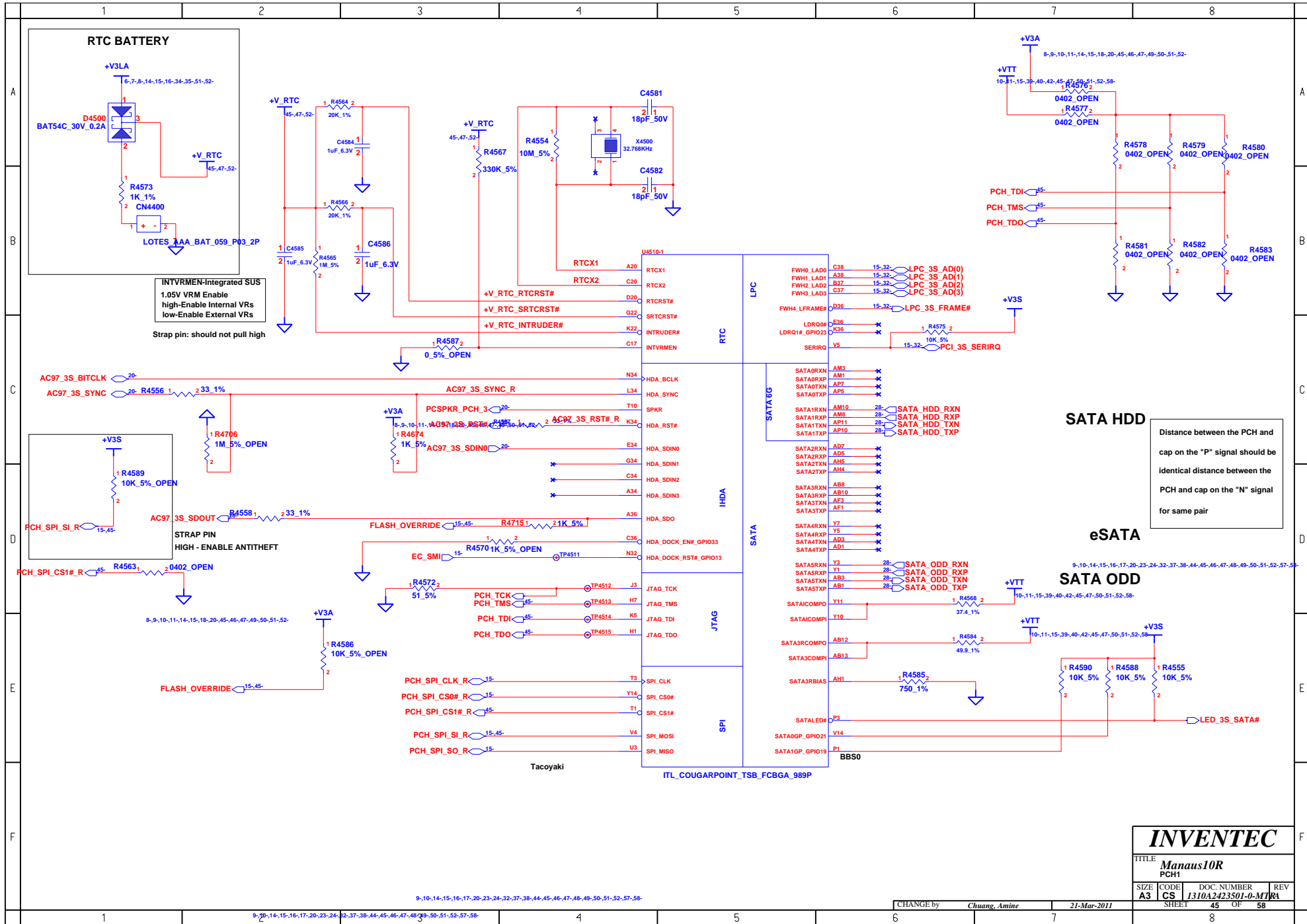

INVENTEC			
TITLE Manaus10R			
PCH1			
SIZE A3	CODE CS	DOC. NUMBER 1310A2423501-0-MT	REV 1
CHANGE by <i>Chuang, Amine</i>		21-Mar-2011	
SHEET 45		OF 58	

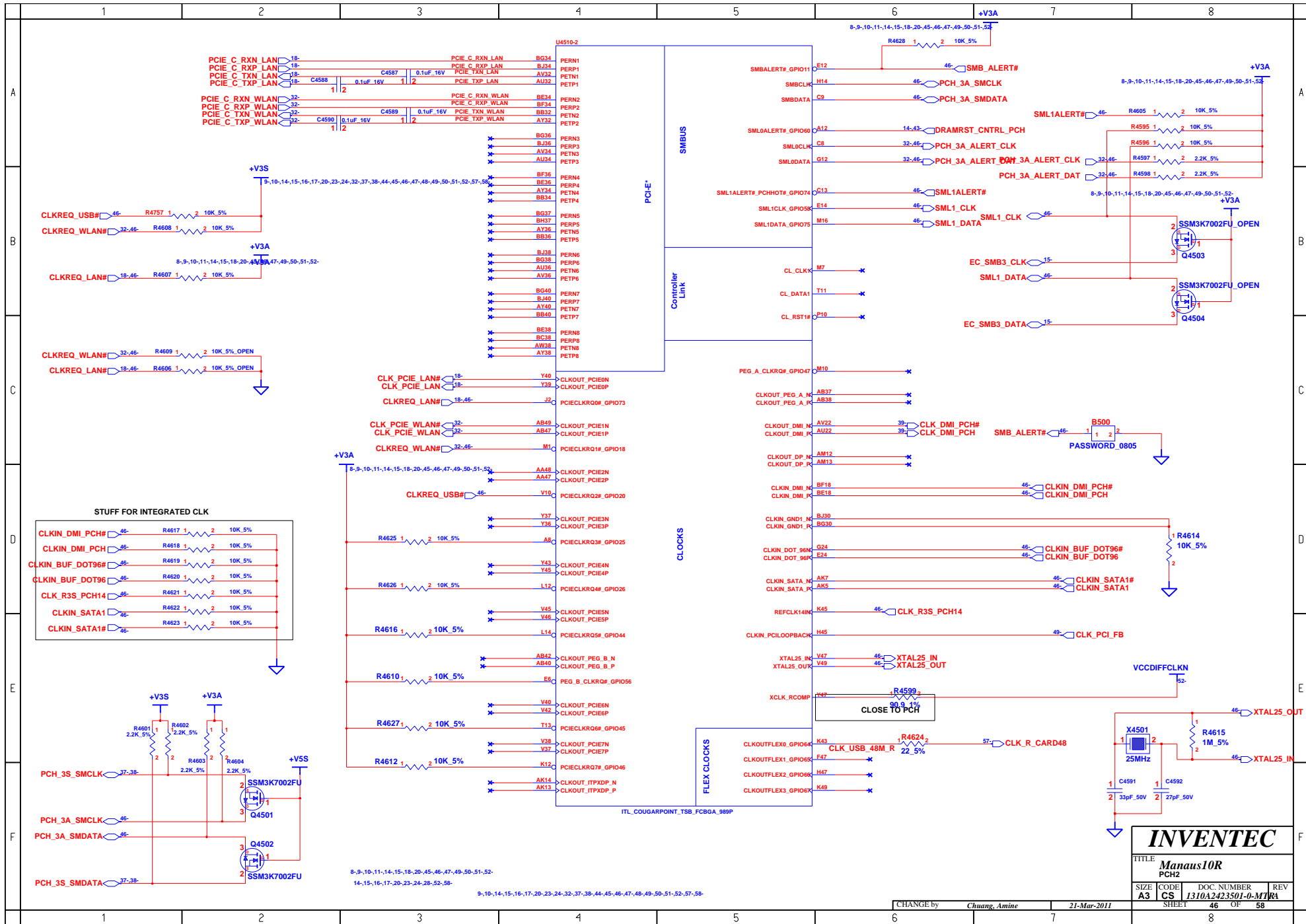

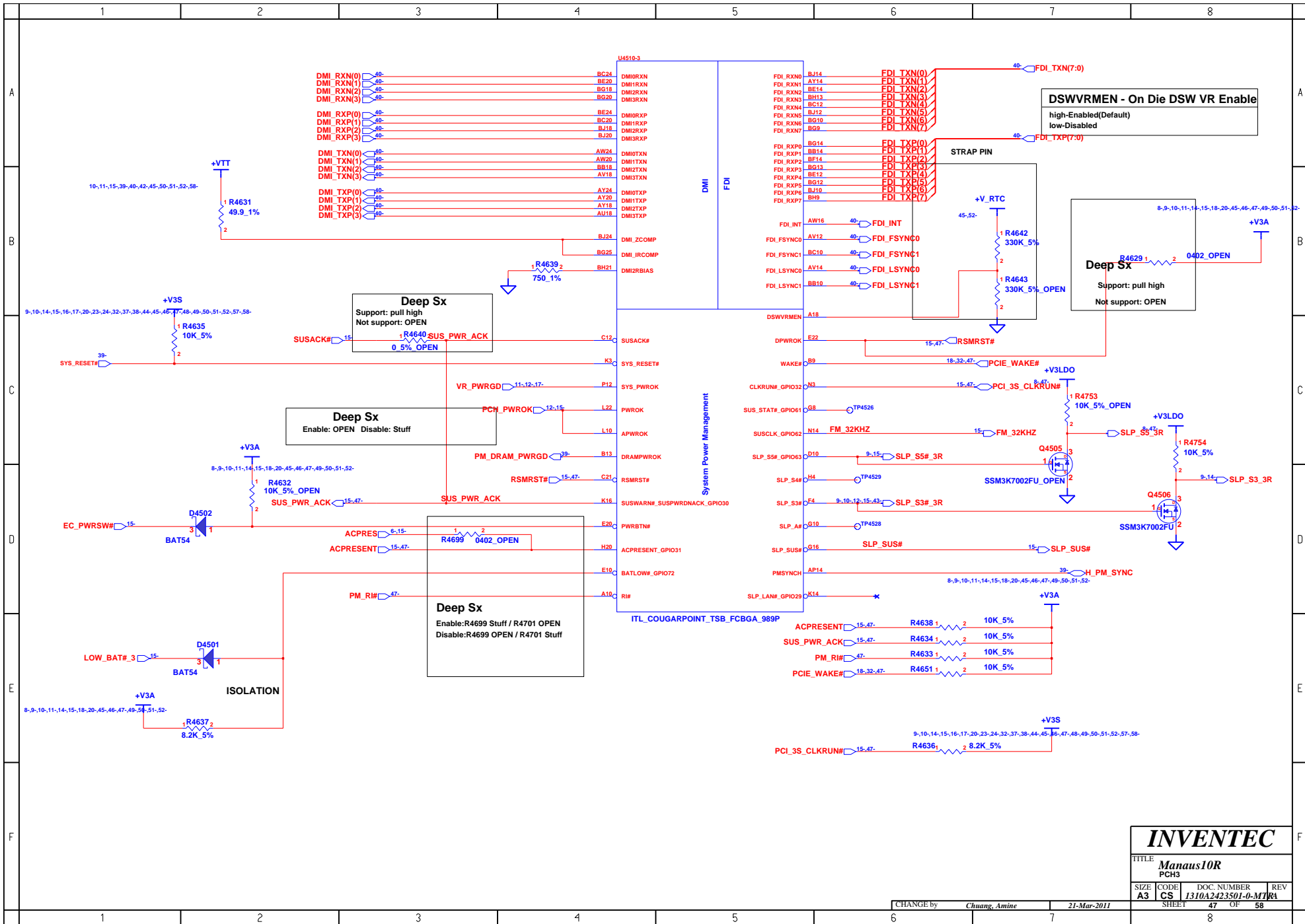

INVENTEC			
TITLE Manaus10R			
PCH3			
SIZE A3	CODE CS	DOC. NUMBER 1310A2423501-0-MTR	REV RA
CHANGE by <i>Chuang, Amine</i>		21-Mar-2011	
SHEET 47		OF 58	

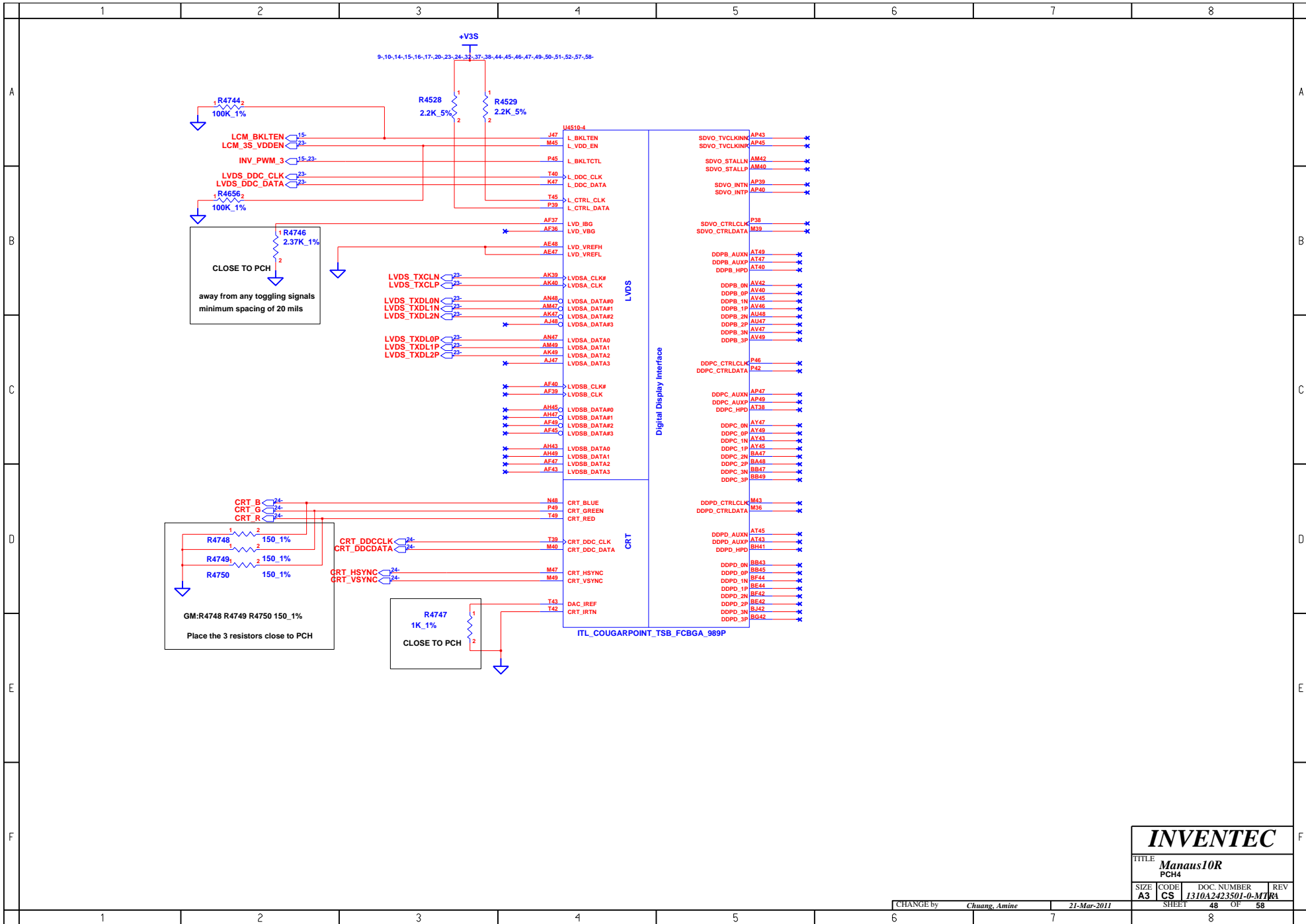

INVENTEC

TITLE			
Manaus10R			
PCH4			
SIZE	CODE	DOC. NUMBER	REV
A3	CS	1310A2423501-0-MTR	KA
SHEET		48	OF 58

CHANGE by Chuang, Amine 21-Mar-2011

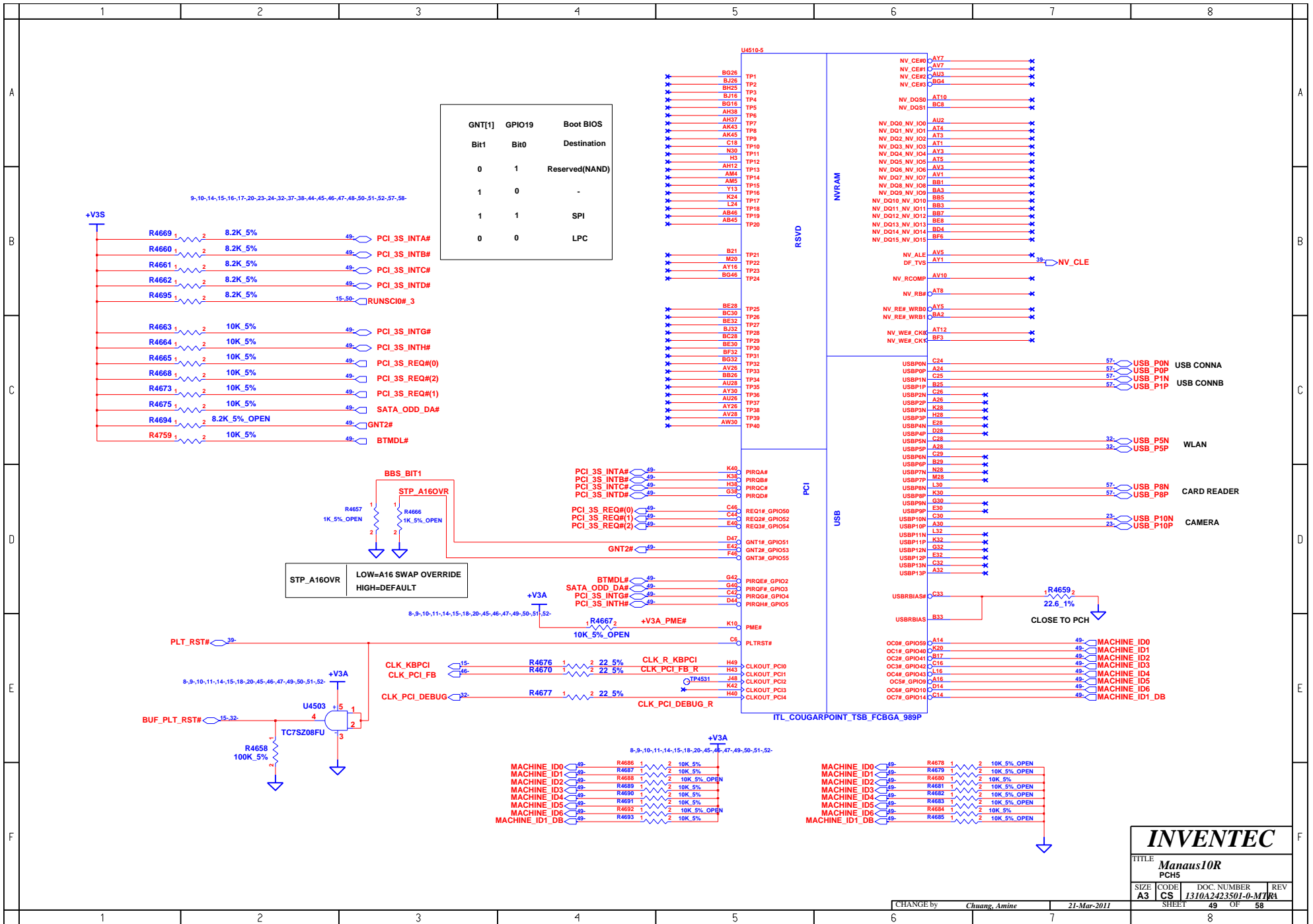

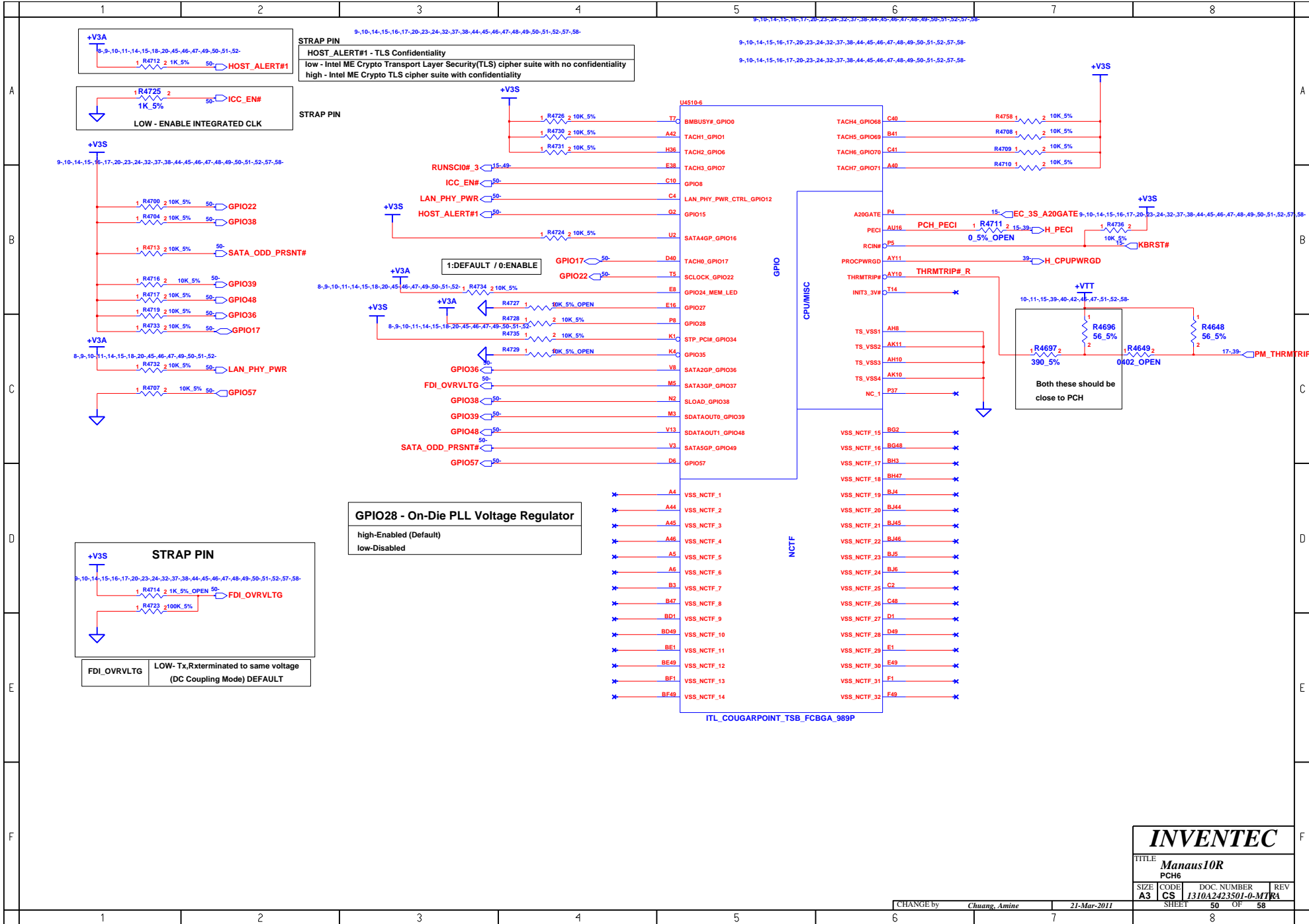

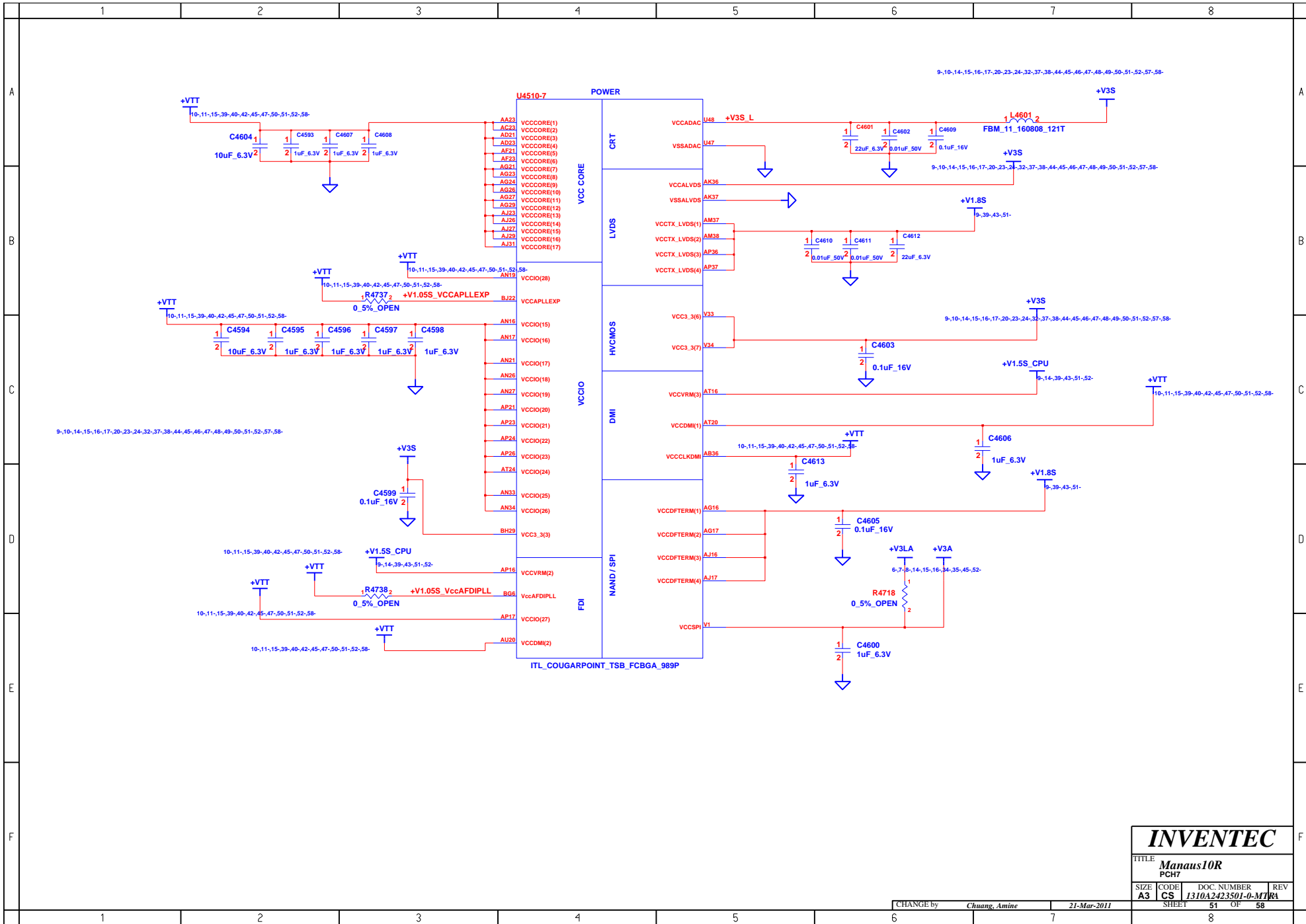

INVENTEC			
TITLE: Manaus10R			
PCH7			
SIZE: A3	CODE: CS	DOC. NUMBER: 1310A2423501-0-MTR	REV: KA
CHANGE by: <i>Chuang, Amine</i>		21-Mar-2011	
SHEET: 51		OF: 58	

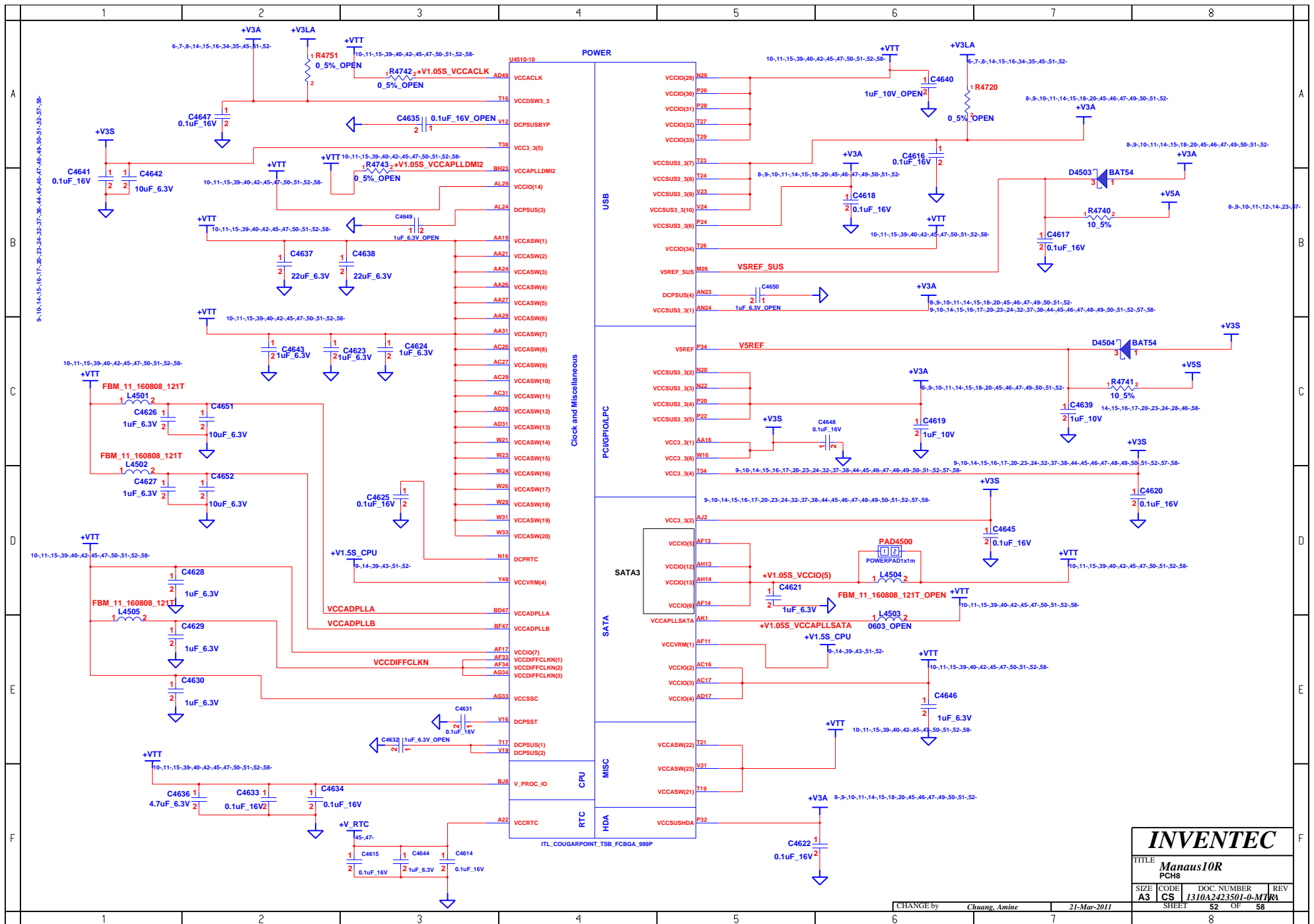

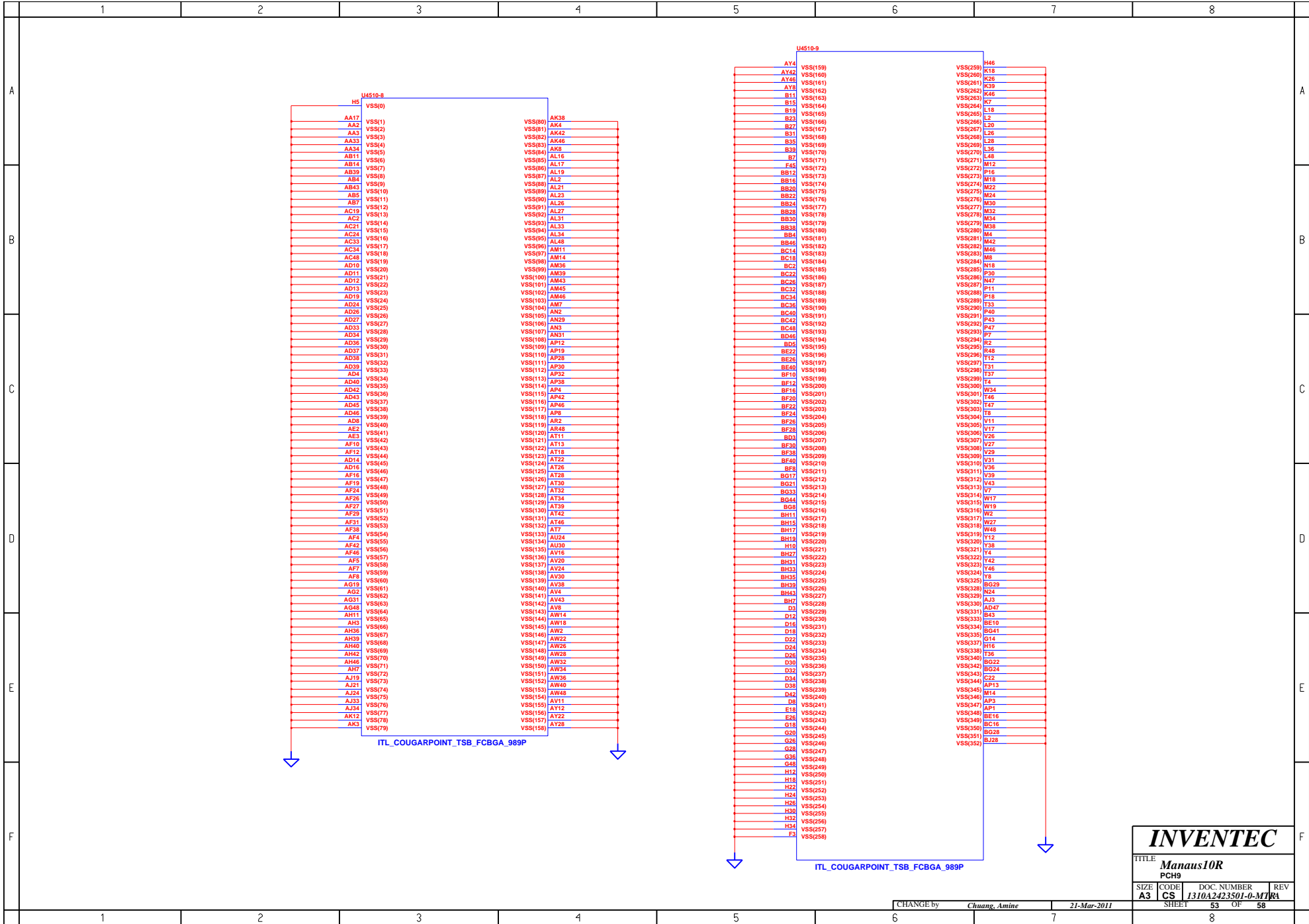

INVENTEC

TITLE **Manaus10R**

PCH9

SIZE	CODE	DOC. NUMBER	REV
A3	CS	1310A2423501-0-M1	KA

SHEET 53 OF 58

CHANGE by *Chuang, Amine* 21-Mar-2011

PICK BUTTON

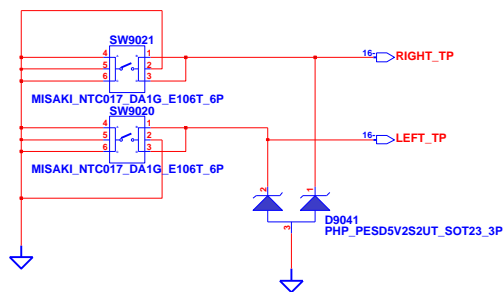

INVENTEC			
TITLE			
Manaus10R			
PICK BUTTON			
SIZE	CODE	DOC. NUMBER	REV
A3	CS	1310A2423501-0-MJ	KA
CHANGE by		21-Mar-2011	
SHEET		54	OF 58

SKIP

INVENTEC			
TITLE Manaus10R			
SIZE	CODE	DOC. NUMBER	REV
A3	CS	1310A2423501-0-MT	RA
CHANGE by		21-Mar-2011	
SHEET		55 OF 58	

POWER BUTTON

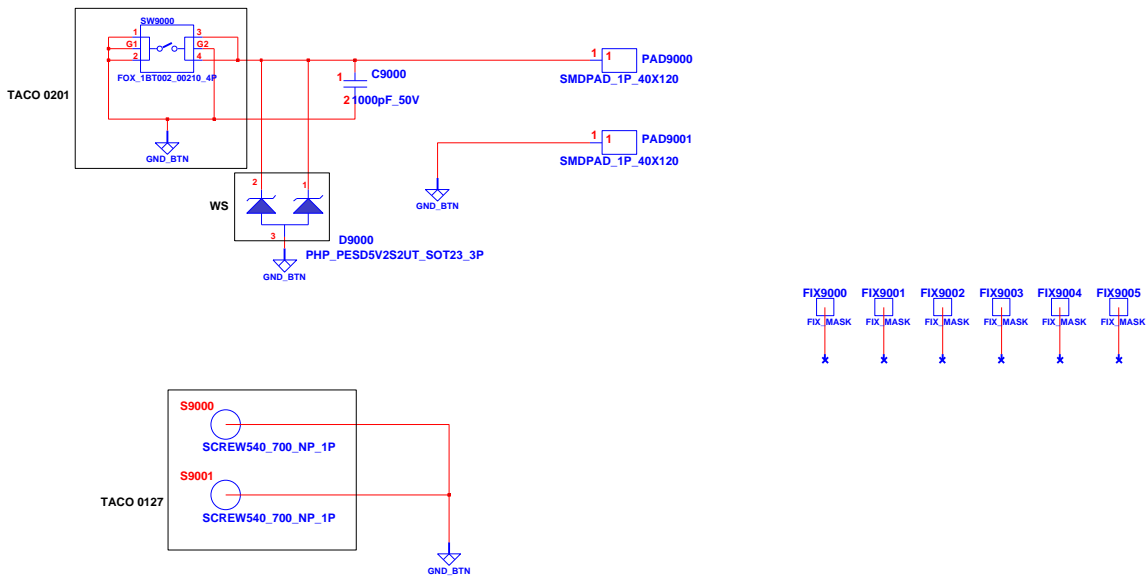

INVENTEC			
TITLE Manaus10R POWER BUTTON BOARD			
SIZE A3	CODE CS	DOC. NUMBER 1310A2423501-0-M1	REV KA
CHANGE by <i>Chuang, Amine</i>		21-Mar-2011	
SHEET 56		OF 58	

CARD READER & USB BOARD

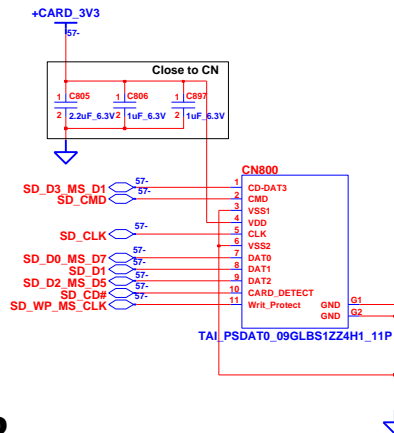
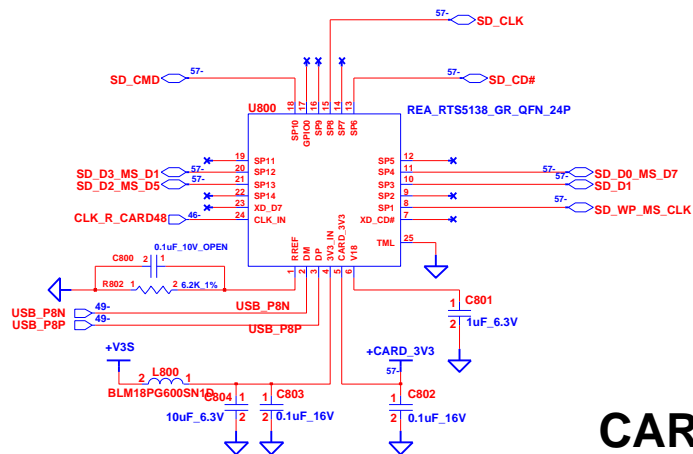
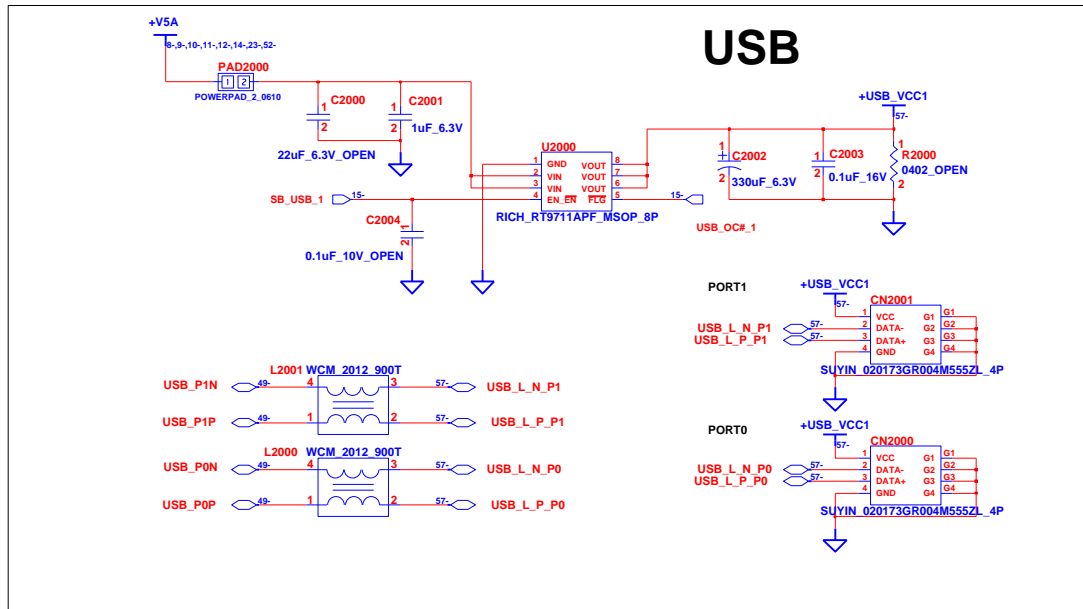

CARD READER

INVENTEC			
TITLE Manaus10R CARDREADER & USB			
SIZE A3	CODE CS	DOC. NUMBER 1310A2423501-0-M1	REV RA
CHANGE by <i>Chuang, Amine</i>		21-Mar-2011	
SHEET 57		OF 58	

EMI

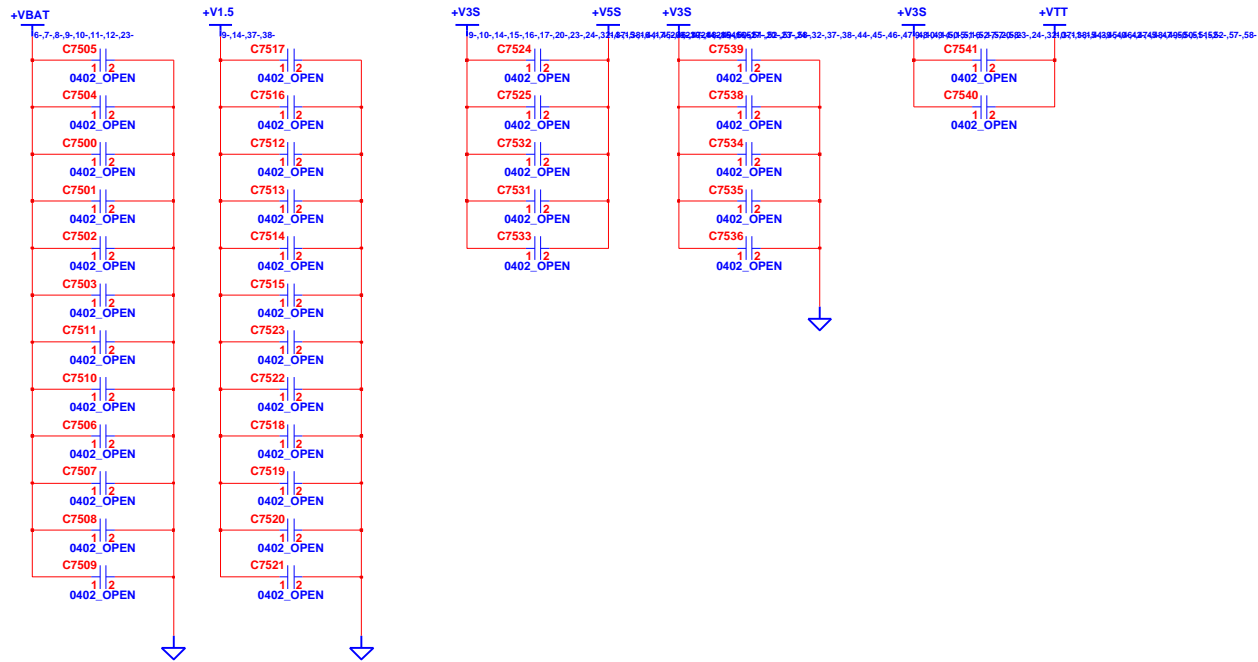

INVENTEC			
TITLE <i>Manaus10R</i>			
EMI			
SIZE A3	CODE CS	DOC. NUMBER <i>1310A2423501-0-MT</i>	REV RA
CHANGE by <i>Chuang, Amine</i>		21-Mar-2011	
		SHEET	58 OF 58