

SY2 BLOCK DIAGRAM

01

CPU
Atom N270/N280
437 PIN (FCBGA)
22mm x 22mm P3,4

CPU Thermal Sensor P3

CLOCK GEN
SLG8SP513VTR P2

NB
INTEL 945GSE
998PIN (FCBGA)
27mm x 27mm P5,6,7,8,9

DDRII SO-DIMM P11

533/400 MHZ
Single Channel

FSB 667/533Mhz

Battery

DC In

DC/DC & Charge P32

VGA

CRT P10

1x LVDS

LCD P7

SB
ICH7-M
652 BGA
31mm x 31mm
32.768MHz P12,13,14,15

USB CNN x2 P25

USB2<PORT0-1>

Bluetooth P22

USB1<PORT3>

Camera P7

USB1<PORT7>

DMI x2

1X PCI-E<GPP_PORT1>

LAN 10/100 AR8132M P23

RJ-45 P23

1X PCI-E<GPP_PORT2>

Wi-LAN P16

SATA<PORT0>

2.5-inch HDD P24

PATA

SSD P24

PCI 33Mhz

Ricoh R5C833 P17

MS-DUO Card P17

SD Card P17

HD Audio

Codec ALC262 P19

Digital Mic P7

MIC-In Jack P21

HP-Out Jack P21

AMP TPA2017D2

Int. Speaker 2W x2 P20

LPC 33Mhz

Touch PAD P22

PCU
WPCE775L P18
32.768MHz

BIOS
1MB FLASH P18

QUANTA COMPUTER

Title: **BLOCK DIAGRAM**

Size: Custom	Document Number: SY2 MB	Rev: 2C
Date: Friday, April 10, 2009	Sheet: 1 of 36	

1. Level 1 Environment-related Substances Should NEVER be Used.
2. Purchase ink, paint, wire rods, and Molding resins only from the business Partners that Sony approves as Green Partners.

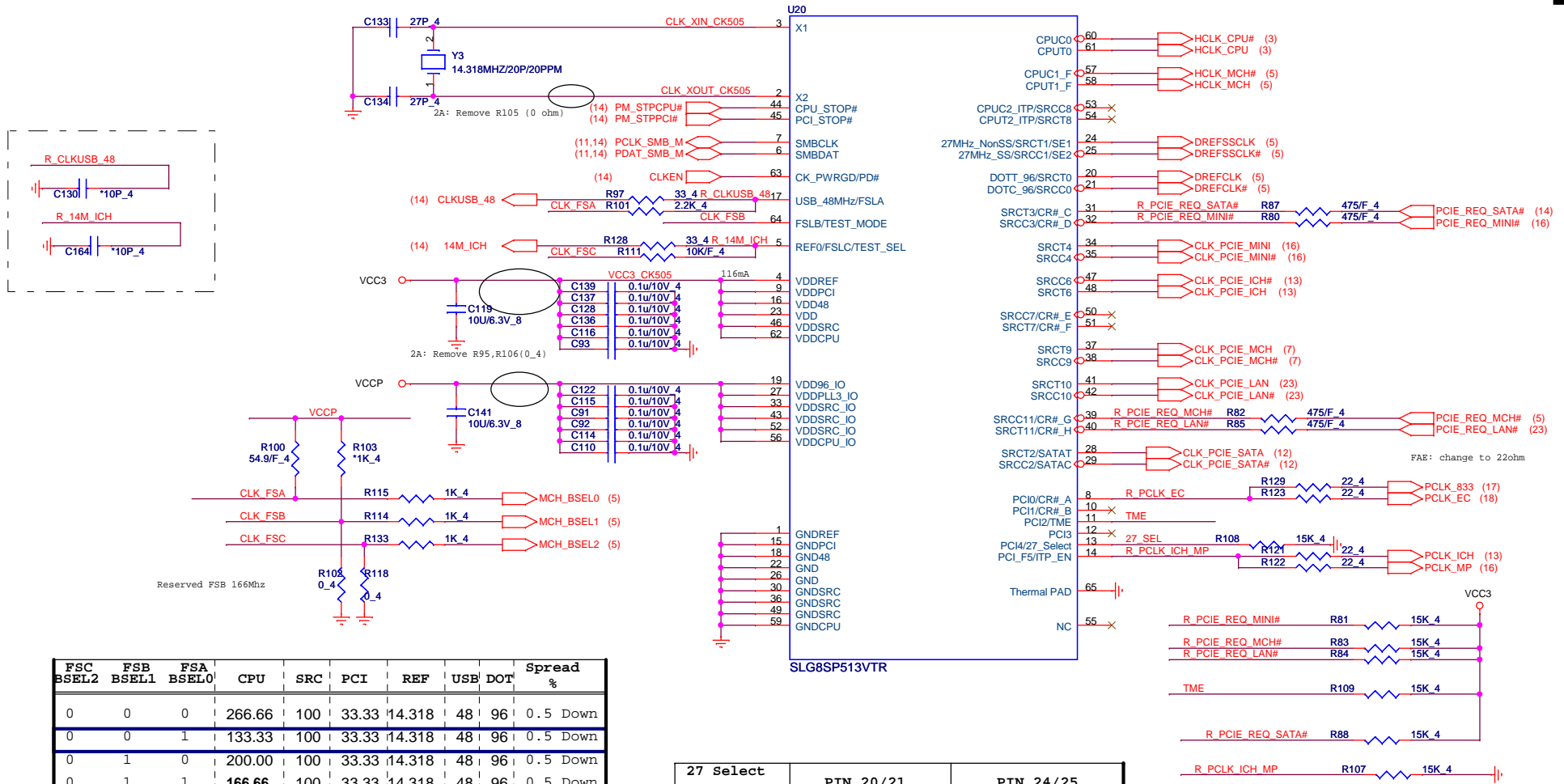

FSC	FSB	FSA	CPU	SRC	PCI	REF	USB	DOT	Spread %	
BSEL2	BSEL1	BSEL0								
0	0	0	266.66	100	33.33	14.318	48	96	0.5	Down
0	0	1	133.33	100	33.33	14.318	48	96	0.5	Down
0	1	0	200.00	100	33.33	14.318	48	96	0.5	Down
0	1	1	166.66	100	33.33	14.318	48	96	0.5	Down
1	0	0	333.33	100	33.33	14.318	48	96	0.5	Down
1	0	1	100.00	100	33.33	14.318	48	96	0.5	Down
1	1	0	400.00	100	33.33	14.318	48	96	0.5	Down
1	1	1								RESERVED

27 Select	PIN13	PIN 20/21	PIN 24/25
*	0	DOT_96 / DOT_96#	LCDCLK / LCDCLK#
	1	SRC_0 / SRC_0#	27M / 27M_SS

ITP_EN (PIN14)	PIN53/54
* 0	SRC8# / SRC8
1	ITP / ITP#

1. Level 1 Environment-related Substances should NEVER be Used.
 2. Purchase ink, paint, wire rods, and Molding resins only from the business Partners that Sony approves as Green Partners.

QUANTA COMPUTER

Title: **CLKGEN**

Size Custom: Document Number **SY2 MB** Rev 2C

Date: Friday, April 10, 2009 Sheet 2 of 36

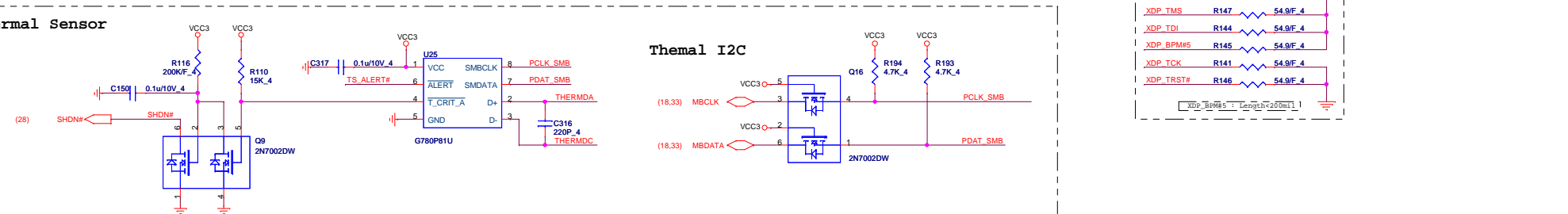
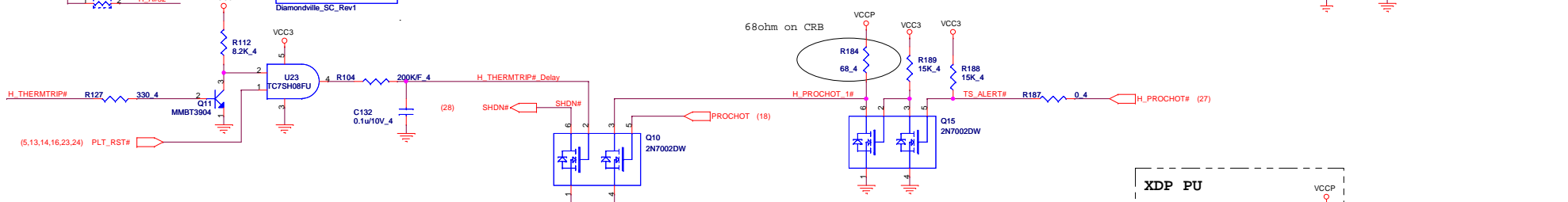
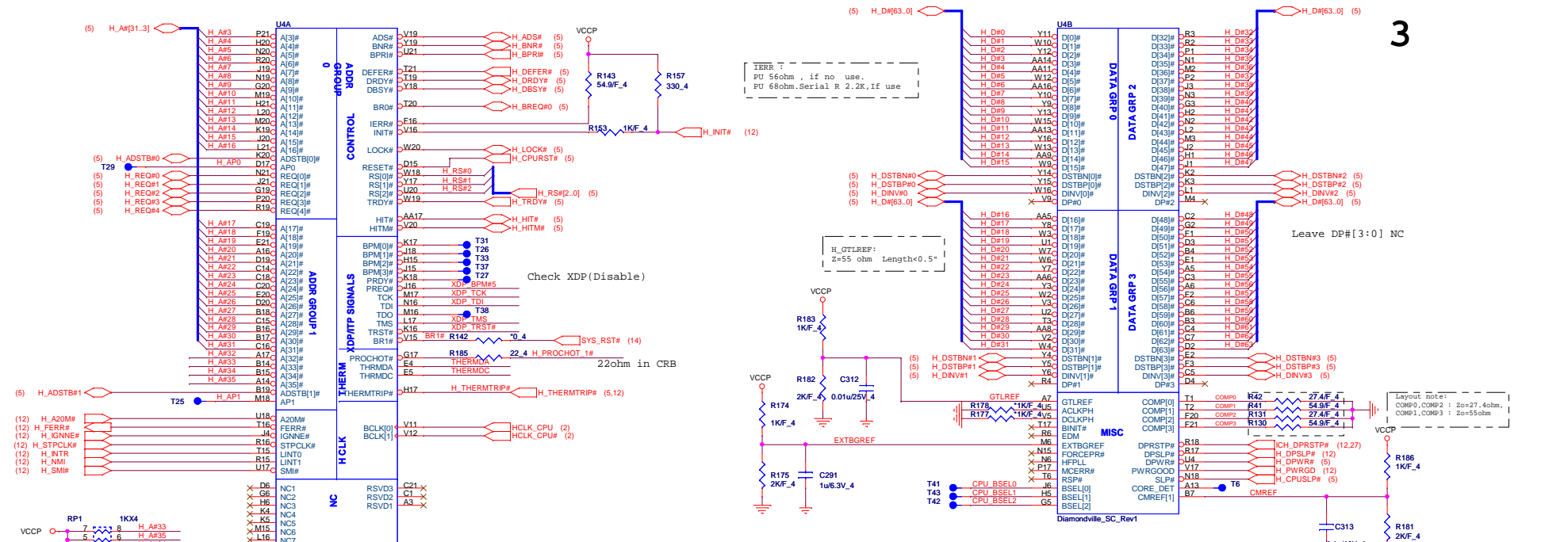

1.Level 1 Environment-related Substances Should NEVER be Used.
 2.Purchase Ink, paint, wire rods, and Molding resins only from the business Partners that Sony approves as Green Partners.

QUANTA COMPUTER

File
CPU(1 of 2)

Size
 Document Number
SY2 MB

Date: Friday, April 10, 2009
 Sheet 3 of 36

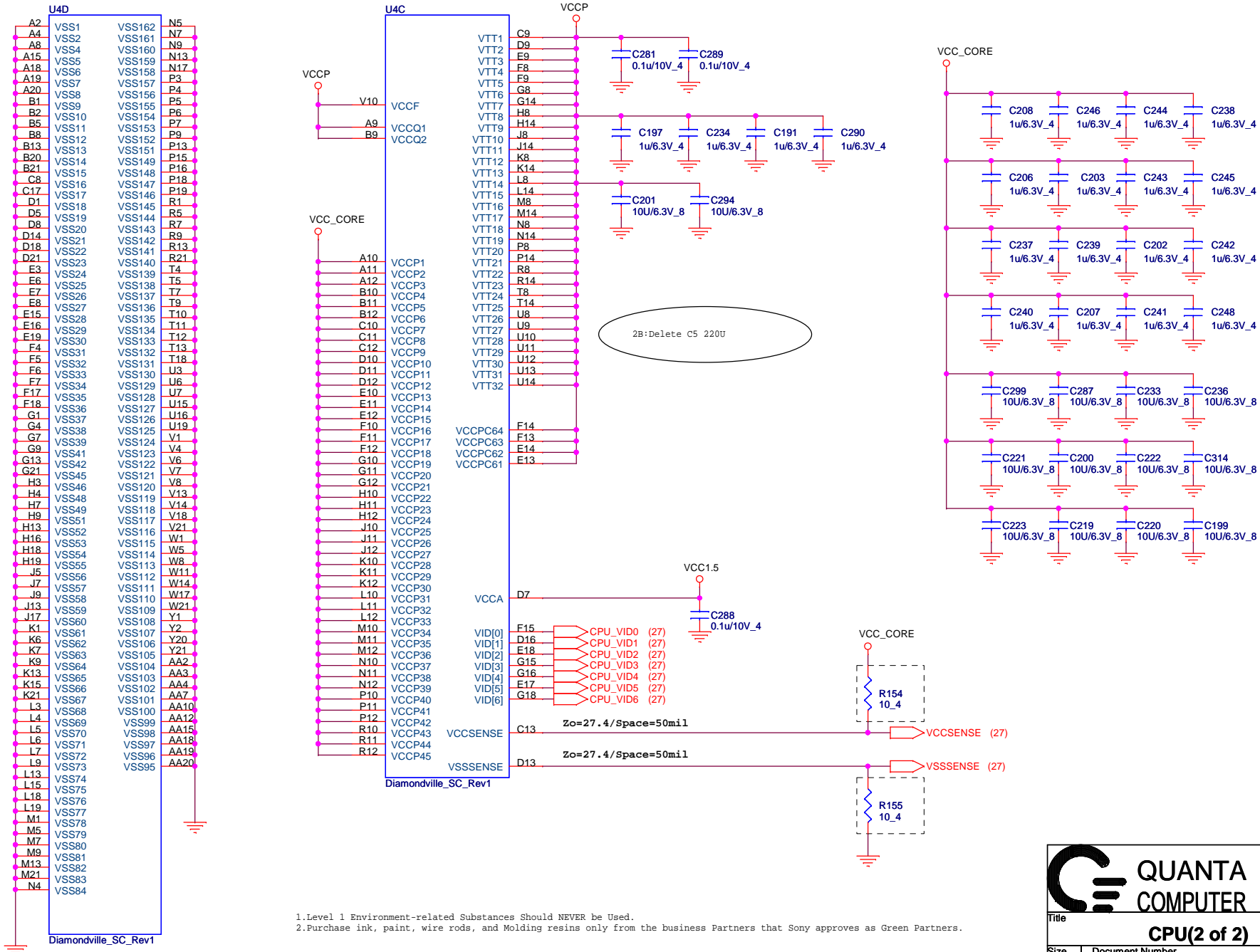

1.Level 1 Environment-related Substances Should NEVER be Used.
 2.Purchase ink, paint, wire rods, and Molding resins only from the business Partners that Sony approves as Green Partners.

QUANTA COMPUTER

Title: **CPU(2 of 2)**

Size: Custom	Document Number: SY2 MB	Rev: 2C
Date: Friday, April 10, 2009		Sheet: 4 of 36

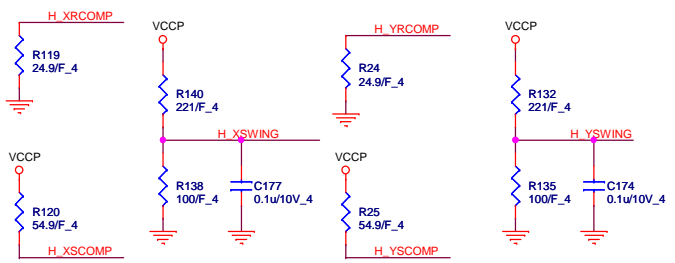
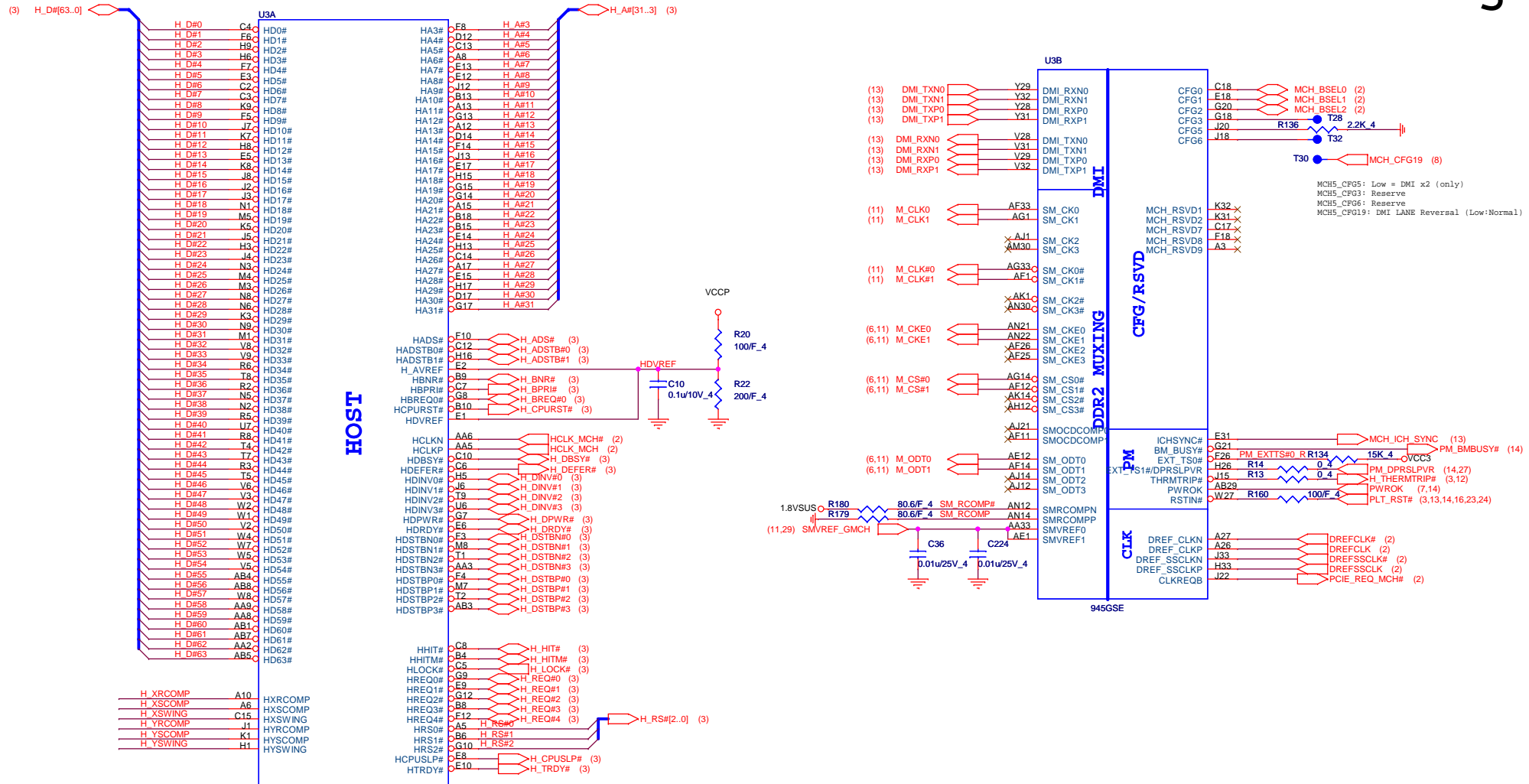

1. Level 1 Environment-related Substances should NEVER be Used.
 2. Purchase ink, paint, wire rods, and Welding resins only from the business Partners that Sony approves as Green Partners.

QUANTA COMPUTER

Title: **GMCH HOST(1 of 5)**

Size	Document Number	Rev
Custom	SY2 MB	2C

Date: Friday, April 10, 2009 Sheet 5 of 36

(11) M_A_DQ[63..0]

U3C

M_A_DQ0	AC31	SA_DQ0
M_A_DQ1	AB28	SA_DQ1
M_A_DQ2	AE33	SA_DQ2
M_A_DQ3	AF32	SA_DQ3
M_A_DQ4	AC33	SA_DQ4
M_A_DQ5	AB32	SA_DQ5
M_A_DQ6	AB31	SA_DQ6
M_A_DQ7	AE31	SA_DQ7
M_A_DQ8	AH31	SA_DQ8
M_A_DQ9	AK31	SA_DQ9
M_A_DQ10	AL28	SA_DQ10
M_A_DQ11	AK27	SA_DQ11
M_A_DQ12	AH30	SA_DQ12
M_A_DQ13	AL32	SA_DQ13
M_A_DQ14	AJ28	SA_DQ14
M_A_DQ15	AJ27	SA_DQ15
M_A_DQ16	AH32	SA_DQ16
M_A_DQ17	AF31	SA_DQ17
M_A_DQ18	AH27	SA_DQ18
M_A_DQ19	AE28	SA_DQ19
M_A_DQ20	AJ32	SA_DQ20
M_A_DQ21	AG31	SA_DQ21
M_A_DQ22	AG28	SA_DQ22
M_A_DQ23	AG27	SA_DQ23
M_A_DQ24	AN27	SA_DQ24
M_A_DQ25	AM26	SA_DQ25
M_A_DQ26	AJ26	SA_DQ26
M_A_DQ27	AJ25	SA_DQ27
M_A_DQ28	AL27	SA_DQ28
M_A_DQ29	AN26	SA_DQ29
M_A_DQ30	AH25	SA_DQ30
M_A_DQ31	AG26	SA_DQ31
M_A_DQ32	AM12	SA_DQ32
M_A_DQ33	AL11	SA_DQ33
M_A_DQ34	AH9	SA_DQ34
M_A_DQ35	AK9	SA_DQ35
M_A_DQ36	AM11	SA_DQ36
M_A_DQ37	AK11	SA_DQ37
M_A_DQ38	AM8	SA_DQ38
M_A_DQ39	AK8	SA_DQ39
M_A_DQ40	AG9	SA_DQ40
M_A_DQ41	AF9	SA_DQ41
M_A_DQ42	AF8	SA_DQ42
M_A_DQ43	AK6	SA_DQ43
M_A_DQ44	AF7	SA_DQ44
M_A_DQ45	AG11	SA_DQ45
M_A_DQ46	AJ6	SA_DQ46
M_A_DQ47	AH6	SA_DQ47
M_A_DQ48	AN6	SA_DQ48
M_A_DQ49	AM6	SA_DQ49
M_A_DQ50	AK3	SA_DQ50
M_A_DQ51	AL2	SA_DQ51
M_A_DQ52	AM5	SA_DQ52
M_A_DQ53	AL5	SA_DQ53
M_A_DQ54	AJ3	SA_DQ54
M_A_DQ55	AJ2	SA_DQ55
M_A_DQ56	AG2	SA_DQ56
M_A_DQ57	AF3	SA_DQ57
M_A_DQ58	AF7	SA_DQ58
M_A_DQ59	AF6	SA_DQ59
M_A_DQ60	AH5	SA_DQ60
M_A_DQ61	AG3	SA_DQ61
M_A_DQ62	AG5	SA_DQ62
M_A_DQ63	AF5	SA_DQ63

DDR2 SYSTEM MEMORY

SA_BS_0	AK12	M_A_BS0
SA_BS_1	AH11	M_A_BS1
SA_BS_2	AG17	M_A_BS2
SA_DM0	AB30	M_A_DM0
SA_DM1	AL31	M_A_DM1
SA_DM2	AF30	M_A_DM2
SA_DM3	AK26	M_A_DM3
SA_DM4	AL9	M_A_DM4
SA_DM5	AG7	M_A_DM5
SA_DM6	AK5	M_A_DM6
SA_DM7	AH3	M_A_DM7
SA_DQS0	AC28	M_A_DQS0
SA_DQS1	AJ30	M_A_DQS1
SA_DQS2	AK33	M_A_DQS2
SA_DQS3	AL25	M_A_DQS3
SA_DQS4	AN9	M_A_DQS4
SA_DQS5	AH8	M_A_DQS5
SA_DQS6	AM2	M_A_DQS6
SA_DQS7	AE3	M_A_DQS7
SA_DQS0#	AC29	M_A_DQS#0
SA_DQS1#	AK30	M_A_DQS#1
SA_DQS2#	AJ33	M_A_DQS#2
SA_DQS3#	AM25	M_A_DQS#3
SA_DQS4#	AN8	M_A_DQS#4
SA_DQS5#	AJ8	M_A_DQS#5
SA_DQS6#	AM3	M_A_DQS#6
SA_DQS7#	AE2	M_A_DQS#7
SA_MA0	AJ15	M_A_A0
SA_MA1	AM17	M_A_A1
SA_MA2	AM15	M_A_A2
SA_MA3	AH15	M_A_A3
SA_MA4	AK15	M_A_A4
SA_MA5	AN15	M_A_A5
SA_MA6	AJ18	M_A_A6
SA_MA7	AF19	M_A_A7
SA_MA8	AN17	M_A_A8
SA_MA9	AL17	M_A_A9
SA_MA10	AG16	M_A_A10
SA_MA11	AL18	M_A_A11
SA_MA12	AG18	M_A_A12
SA_MA13	AL14	M_A_A13
SA_CAS#	AJ17	M_A_CAS#
SA_RAS#	AK18	M_A_RAS#
SA_RCVENINB	AN28	
SA_RCVENOUTB	AM28	
SA_WEB	AH17	M_A_WE#
SB_BS_0	AH21	
SB_BS_1	AJ20	
SB_BS_2	AE27	
SB_MA0	AN20	
SB_MA1	AL21	
SB_MA2	AK21	
SB_MA3	AK22	
SB_MA4	AL22	
SB_MA5	AH22	
SB_MA6	AG22	
SB_MA7	AF21	
SB_MA8	AM21	
SB_MA9	AE21	
SB_MA10	AL20	
SB_MA11	AE22	
SB_MA12	AE26	
SB_MA13	AE20	

945GSE

6

M_A_BS0	(11)
M_A_BS1	(11)
M_A_BS2	(11)
M_A_DM[7..0]	(11)

M_A_DQS[7..0]	(11)
---------------	------

M_A_DQS#[7..0]	(11)
----------------	------

M_A_A[13..0]	(11)
--------------	------

M_A_CAS#	(11)
M_A_RAS#	(11)
M_A_WE#	(11)

M_A_A3 RN4	1	2	56X4
M_A_A1	3	4	
M_A_A10	5	6	
M_A_A2	7	8	

M_A_A11RN6	1	2	56X4
M_A_A0	3	4	
M_A_BS2	5	6	
M_A_A12	7	8	

M_A_A4 RN5	1	2	56X4
M_A_A9	3	4	
M_A_A8	5	6	
M_A_A5	7	8	

M_CS#0 RN2	1	2	56X4
M_RAS#	3	4	
M_ODT0	5	6	
M_A_A13	7	8	

M_A_BS#RN3	1	2	56X4
M_A_BS0	3	4	
M_A_CAS#	5	6	
M_A_WE#	7	8	

M_CKE1 RN7	1	2	56X4
M_A_A7	3	4	
M_A_A6	5	6	
M_CKE0	7	8	

M_ODT1	1	2	
M_CS#1	3	4	

C334	0.1u/10V	4	VTT_MEM
C328	0.1u/10V	4	
C335	0.1u/10V	4	
C333	0.1u/10V	4	
C339	0.1u/10V	4	
C336	0.1u/10V	4	
C331	0.1u/10V	4	
C341	0.1u/10V	4	
C332	0.1u/10V	4	
C330	0.1u/10V	4	
C340	0.1u/10V	4	
C338	0.1u/10V	4	
C337	0.1u/10V	4	
C329	0.1u/10V	4	



QUANTA COMPUTER

Title		GMCH DDR (2 of 5)	
Size	Document Number	Rev	2C
Custom	SY2 MB		
Date:	Friday, April 10, 2009	Sheet	6 of 36

1.Level 1 Environment-related Substances Should NEVER be Used.
 2.Purchase ink, paint, wire rods, and Molding resins only from the business Partners that Sony approves as Green Partners.

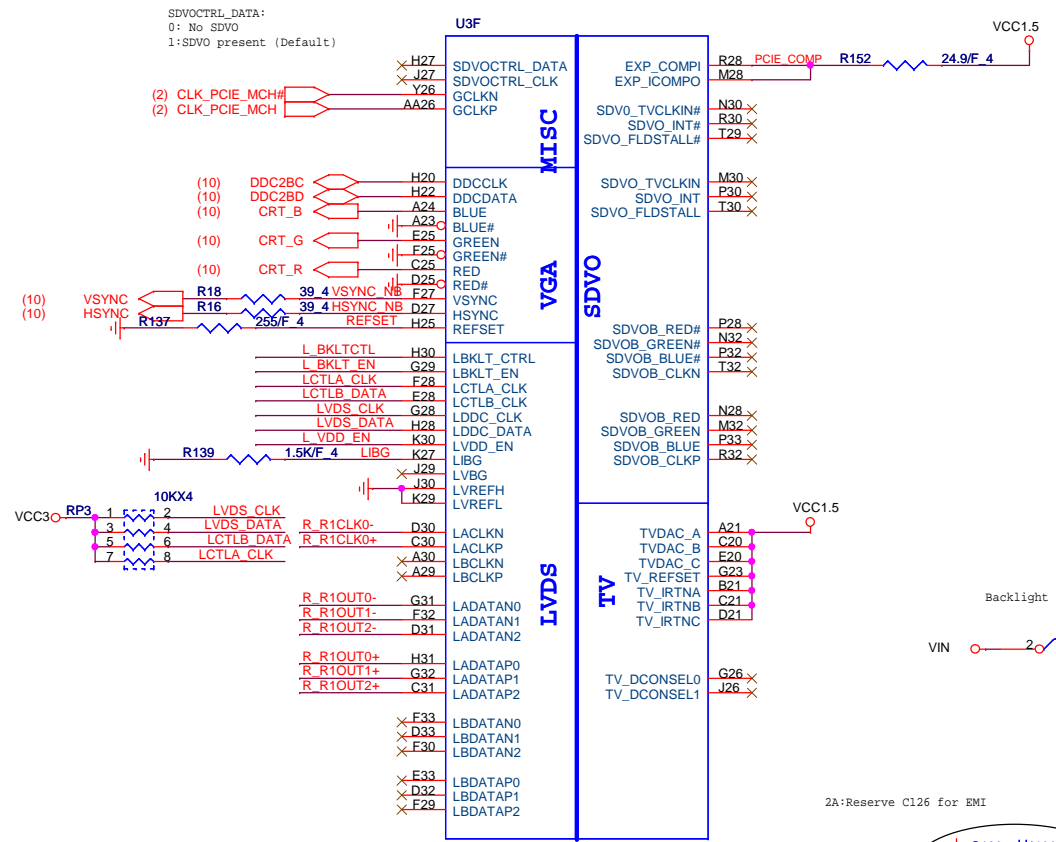

LVDS Enable

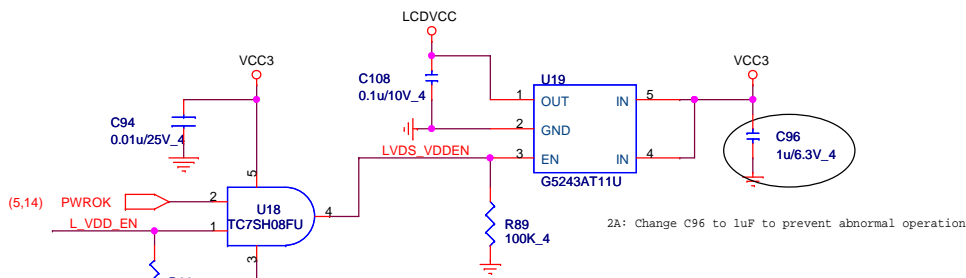

Display On

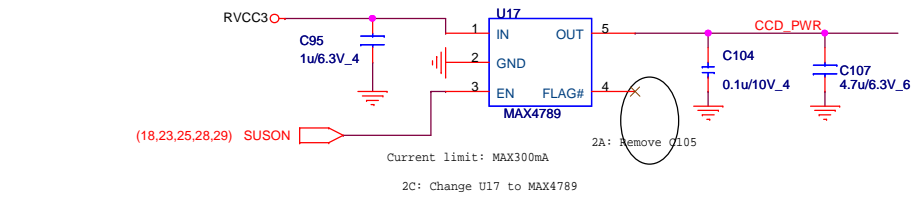
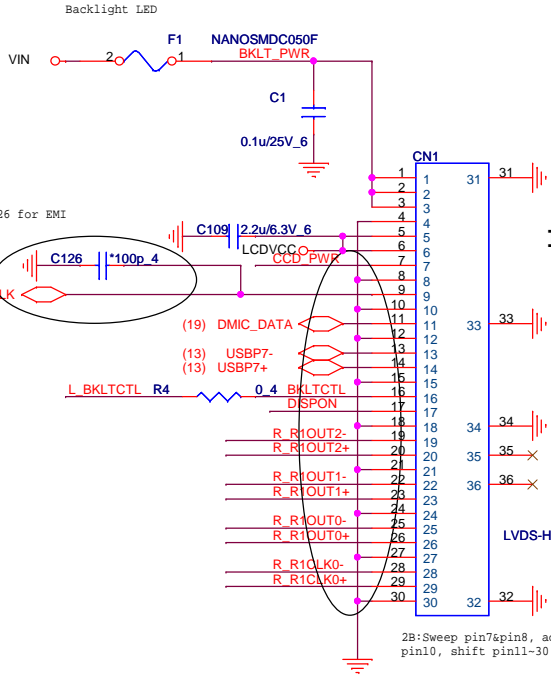
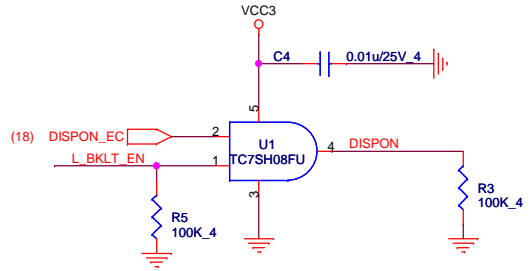

QUANTA COMPUTER

Title: **GMCH DMI VIDEO (3of 5)**

Size: B Document Number: **SY2 MB** Rev: 2C

Date: Friday, April 10, 2009 Sheet: 7 of 36

1. Level 1 Environment-related Substances Should NEVER be Used.
2. Purchase ink, paint, wire rods, and Molding resins only from the business Partners that Sony approves as Green Partners.

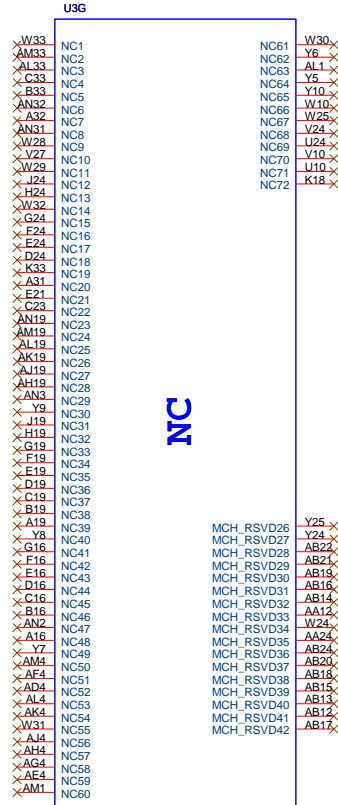
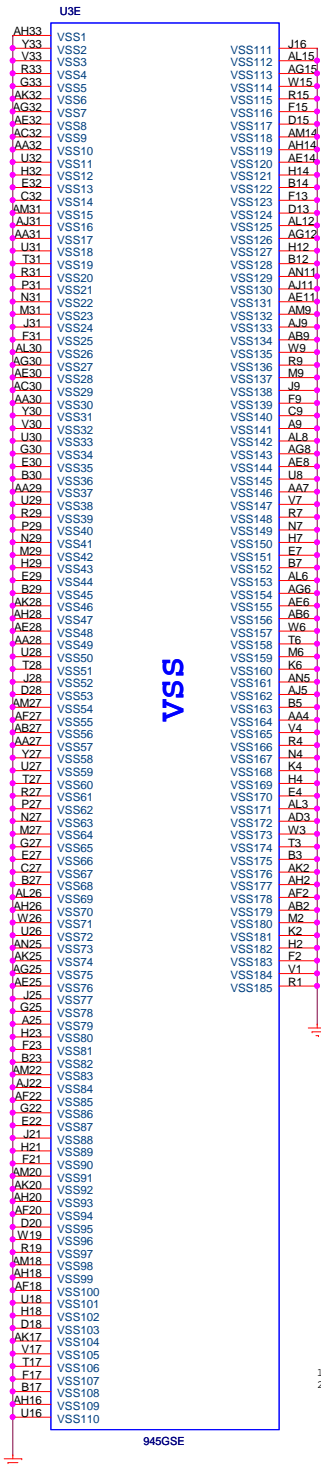

NC

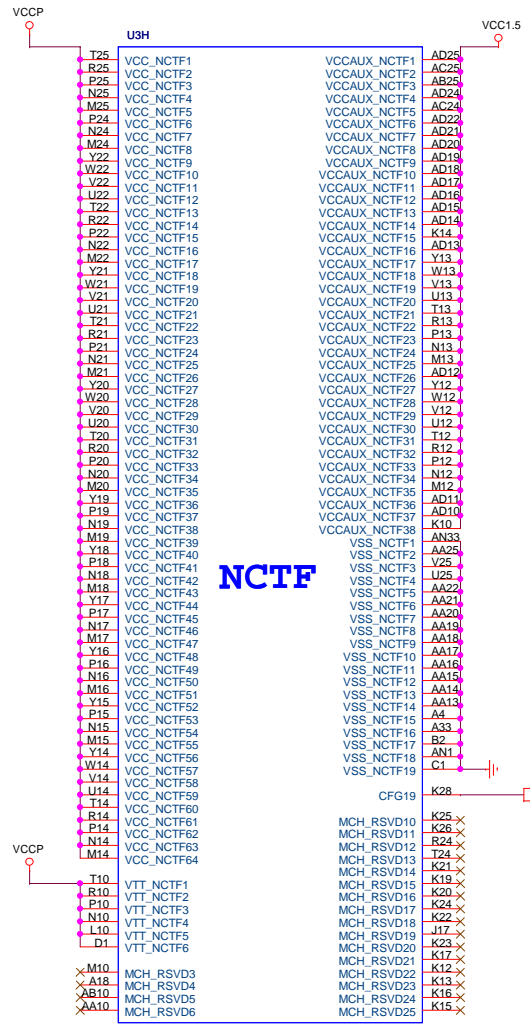

NCTF

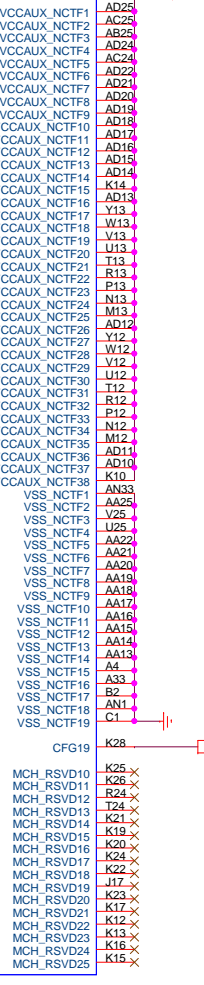

1. Level 1 Environment-related Substances Should NEVER be Used.
 2. Purchase ink, paint, wire rods, and Molding resins only from the business Partners that Sony approves as Green Partners.

QUANTA COMPUTER

Title: **GMCH Power1 (4of 5)**

Size	Document Number	Rev
Custom	SY2 MB	2C

Date: Friday, April 10, 2009 Sheet 8 of 36

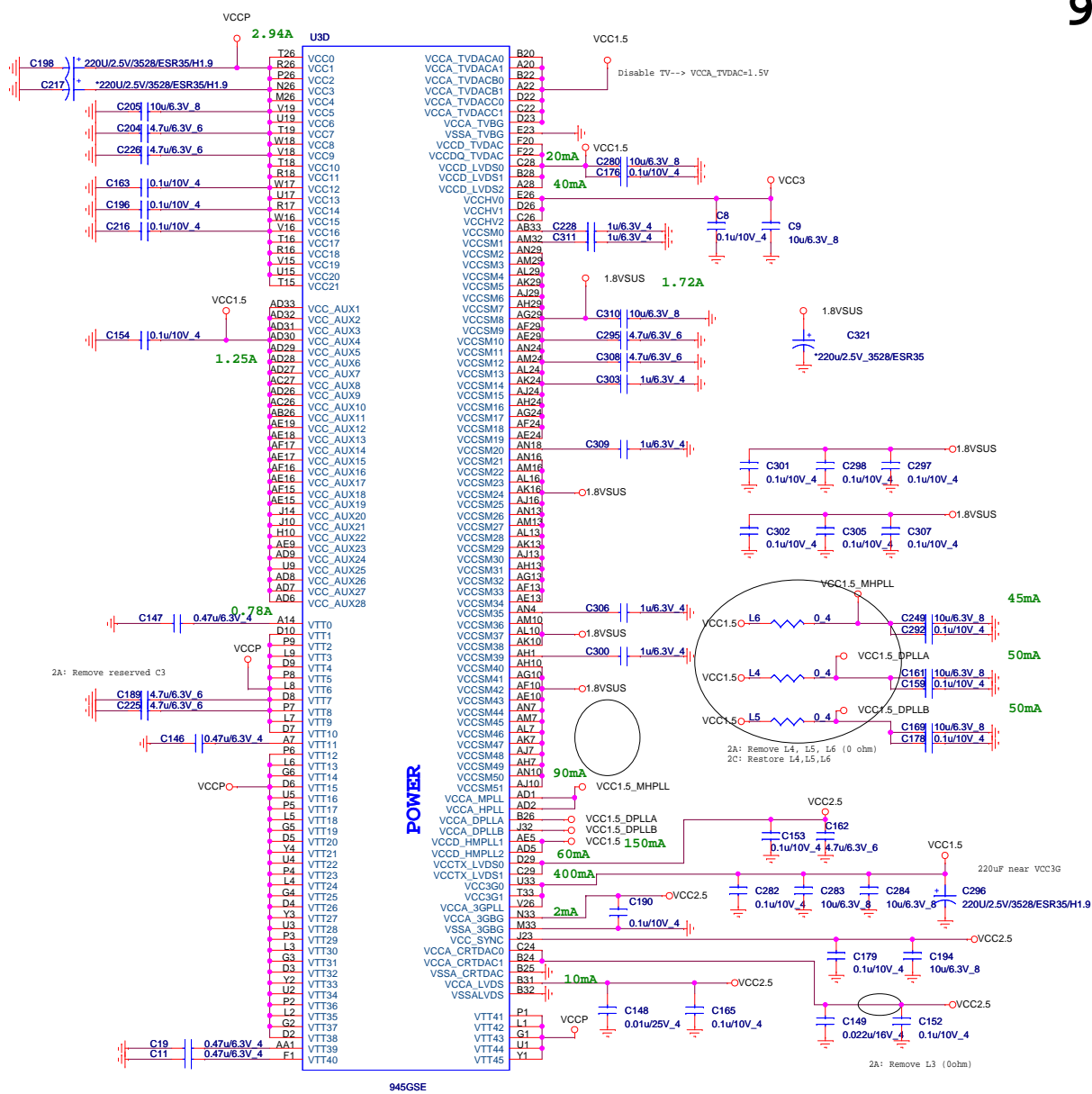

1. Level 1 Environment-related Substances Should NEVER be Used.
 2. Purchase ink, paint, wire rods, and Molding resins only from the business Partners that Sony approves as Green Partners.

**QUANTA
COMPUTER**

GMCH Power 2 (4 of 5)

Size	Document Number	Rev
Custom	SY2 MB	2C
Date: Friday, April 10, 2009		
Sheet 9 of 36		

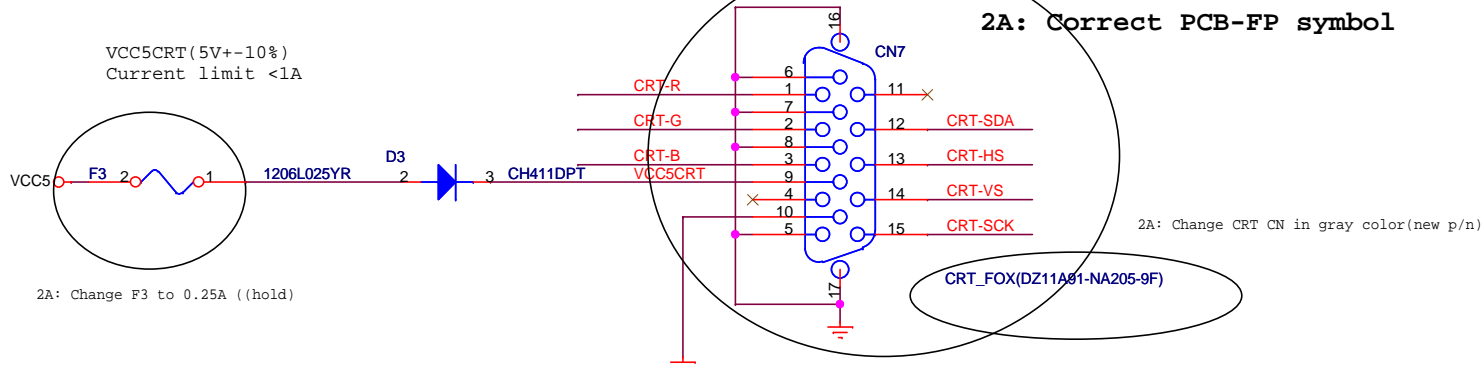
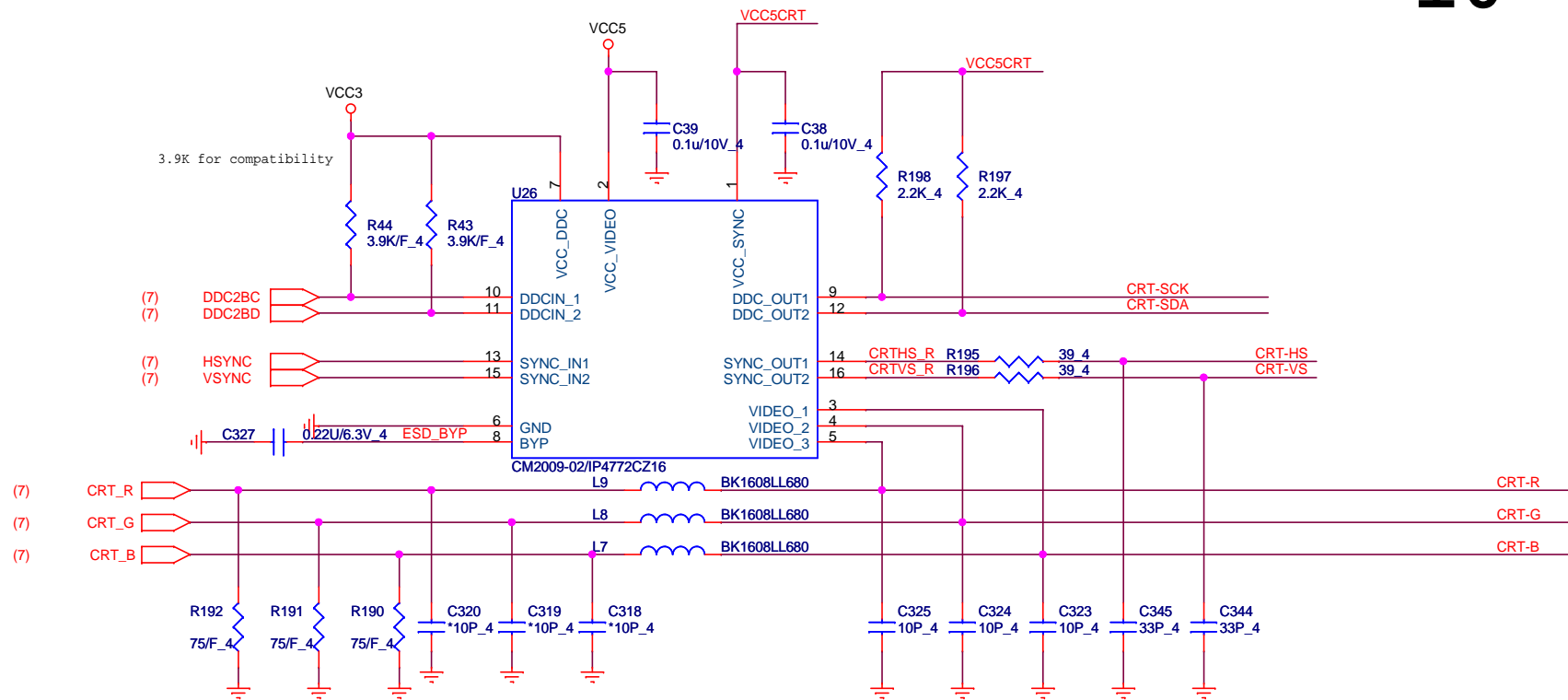

2A: Correct PCB-FP symbol

2A: Change CRT CN in gray color(new p/n)

2A: Change F3 to 0.25A ((hold))



Title			CRT		
Size	Document Number	Rev			
Custom	SY2 MB	2C			
Date:	Friday, April 10, 2009	Sheet	10	of 36	

1.Level 1 Environment-related Substances Should NEVER be Used.
 2.Purchase ink, paint, wire rods, and Molding resins only from the business Partners that Sony approves as Green Partners.

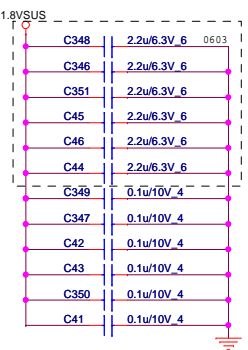
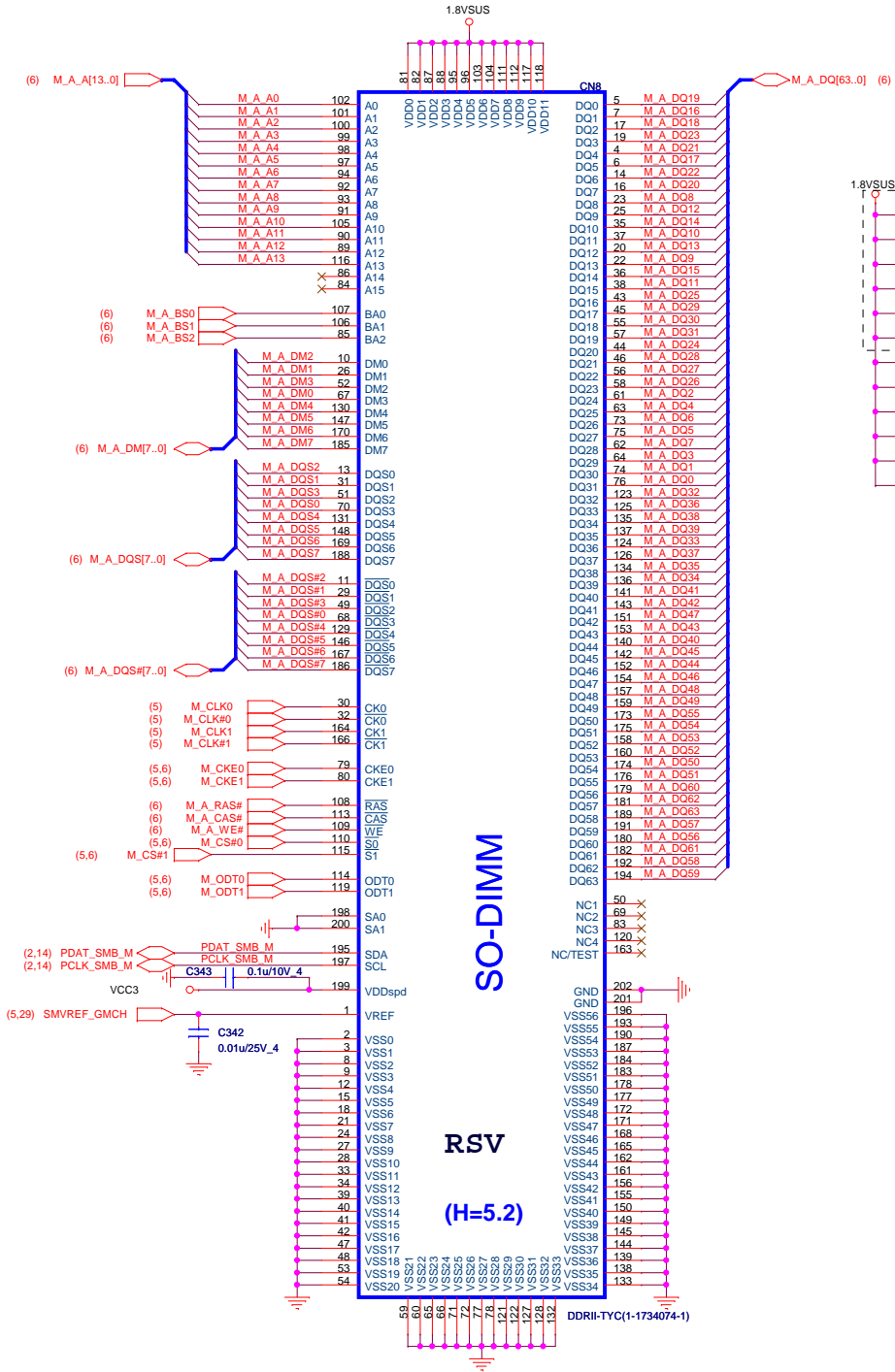

SO-DIMM

RSV (H=5.2)

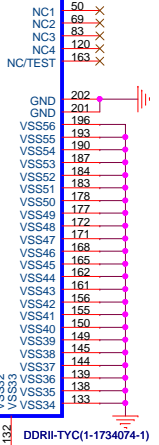

QUANTA COMPUTER

Title: **DDRII SODIMMx1**

Size: Custom | Document Number: **SY2 MB** | Rev: 2C

Date: Friday, April 10, 2009 | Sheet: 11 of 36

1. Level 1 Environment-related Substances Should NEVER be Used.
 2. Purchase ink, paint, wire rods, and Molding resins only from the business Partners that Sony approves as Green Partners.

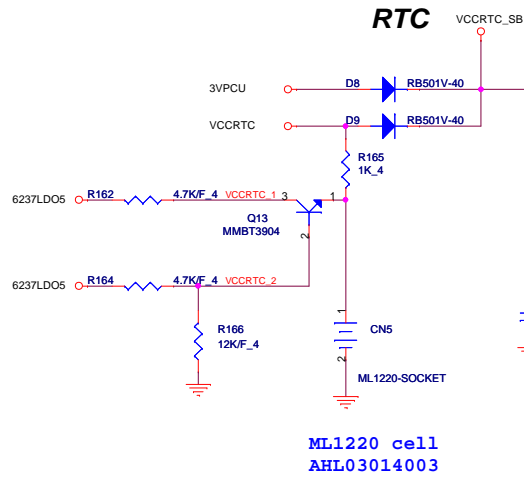

ML1220 cell
AHL03014003

XOR Chain Entrance Strap
PCIE Port configuration

ICH_TP3 (INT PU)	ACZ_SDOUT (INT PD)	ACZ_SYNC (INT PD)	Description
0	0		RSVD
0	1		Enter XOR Chain
1	0	0	* Normal operation 4 x 1s
1	1	1	PCIE Port1 (4x)

Internal VRM Enable for Vccsus1_05

	INTVRMEN
Enable (default)	1
Disable	0

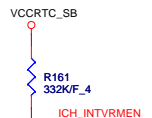

Reserved strapping (PU 15k when PLTRST#)

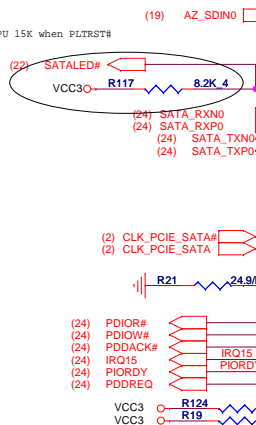

HD to Audio Codec

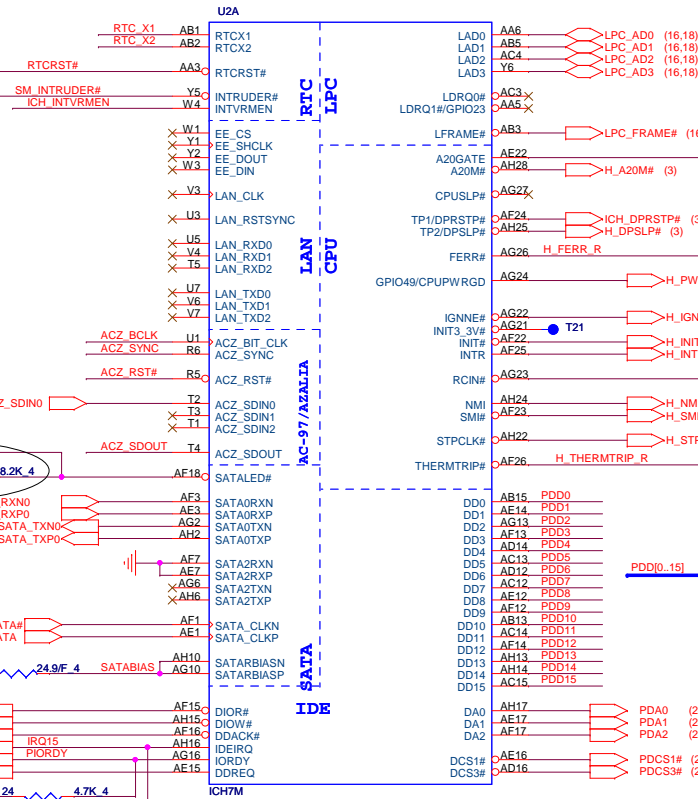
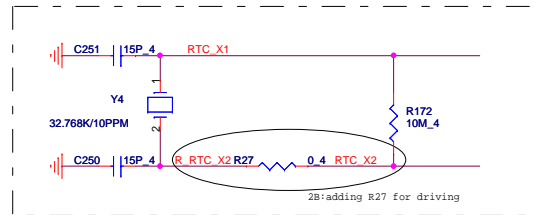

ICH_DPRSTP#: Daisy chain routing
ICH-->IMVP-->CPU

QUANTA COMPUTER

Title: **ICH9-M HOST(1 of 4)**

Size: Custom Document Number: **SY2 MB** Rev: ZC

Date: Friday, April 10, 2009 Sheet: 12 of 36

1. Level 1 Environment-related Substances Should NEVER be Used.
2. Purchase ink, paint, wire rods, and Molding resins only from the business Partners that Sony approves as Green Partners.

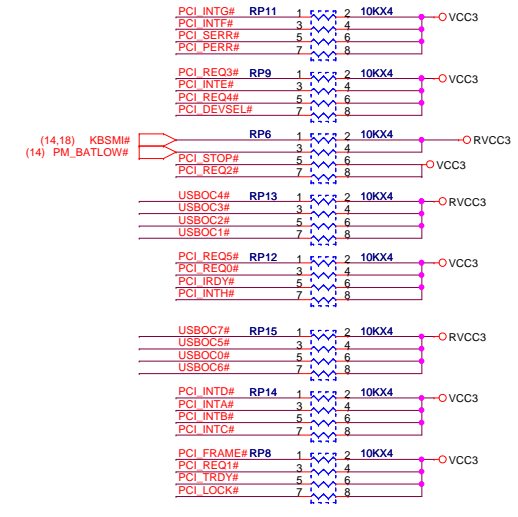
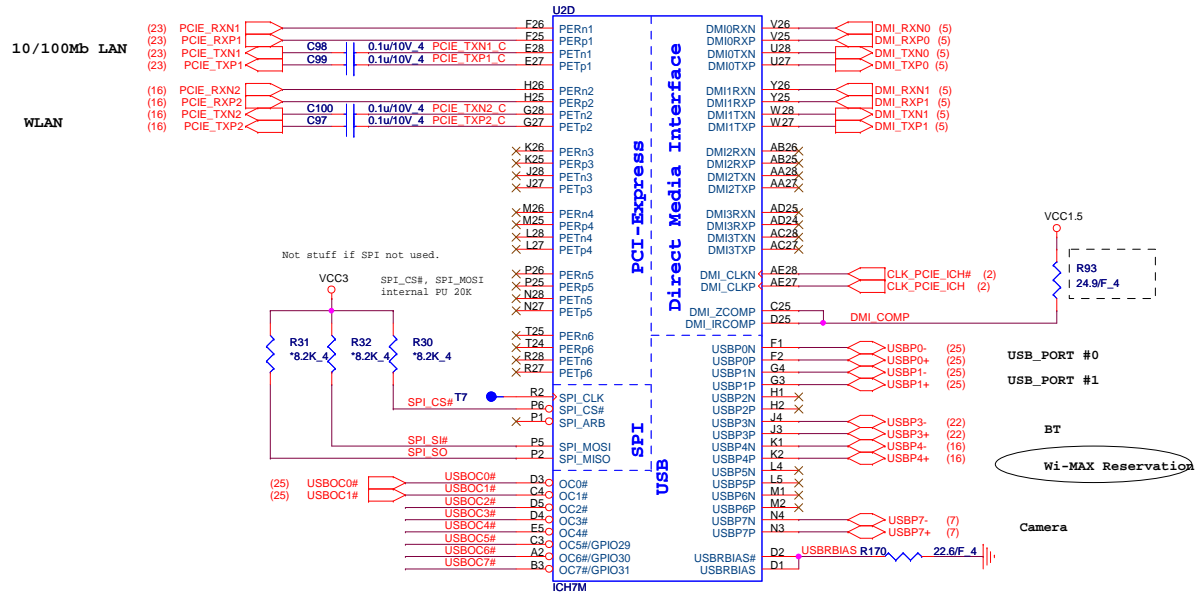

SPI_CS#	Internal PD ;Should not be PU
SPI_MISO	Internal PU ;Should not be PD
PCI_GNT#2	Internal PU Should not be PD
PCI_GNT#3	Low = A16 swap override enabled High = Default

A16 SWAP Override strap

PCI_GNT#5 (INT PU)	PCI_GNT#4 (INT PU)	Boot BIOS Location
0	1	SPI
1	0	PCI
1	1	IPC (Default)

ICH Boot BIOS select

IRQ	Description
PIRQA	USB UHCI Controller #1, #4
PIRQB	AC'97 Codec; option for SMBUS
PIRQC	USB UH Controller #3; SATA/IDE Native Mode
PIRQD	USB UHCI Controller #2
PIRQE	Internal LAN; Option for SCI, TCO, HPET#0,1,2
PIRQF	Option for SCI, TCO, HPET#0,1,2
PIRQG	Option for SCI, TCO, HPET#0,1,2
PIRQH	USB EHCI Controller; Option for SCI, TCO, HPET#0,1,2

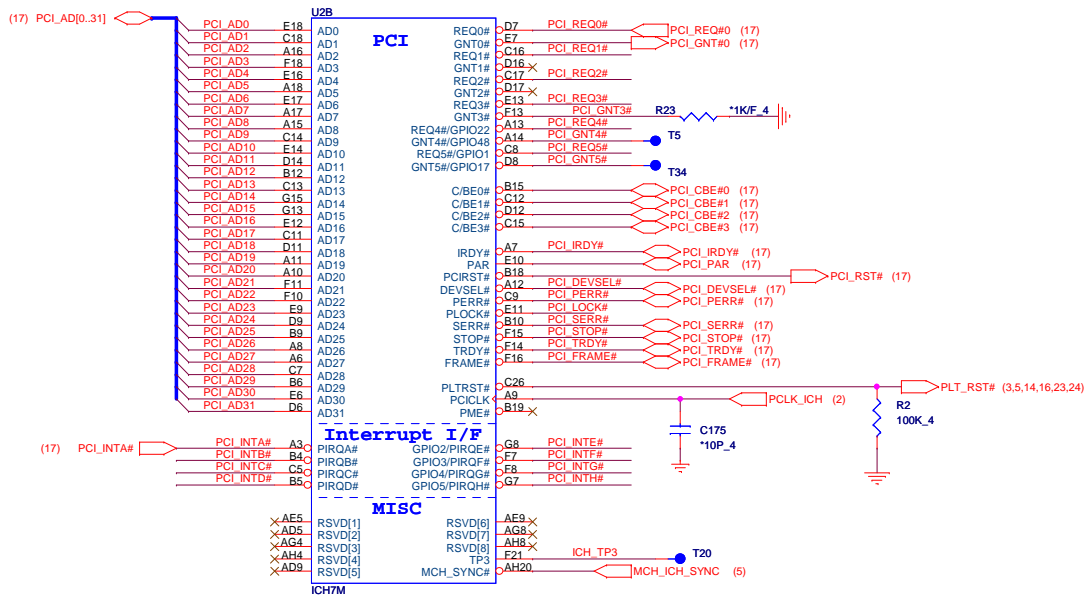

1.Level 1 Environment-related Substances Should NEVER be Used.
 2.Purchase ink, paint, wire rods, and Molding resins only from the business Partners that Sony approves as Green Partners.

QUANTA COMPUTER

Title: **ICH9-M PCI-E, USB, PCI (2 of 4)**

Size	Document Number	Rev
Custom	SY2 MB	2C

Date: Friday, April 10, 2009 Sheet 13 of 36

SM BUS for
DRAM (SPD), CLK-GEN

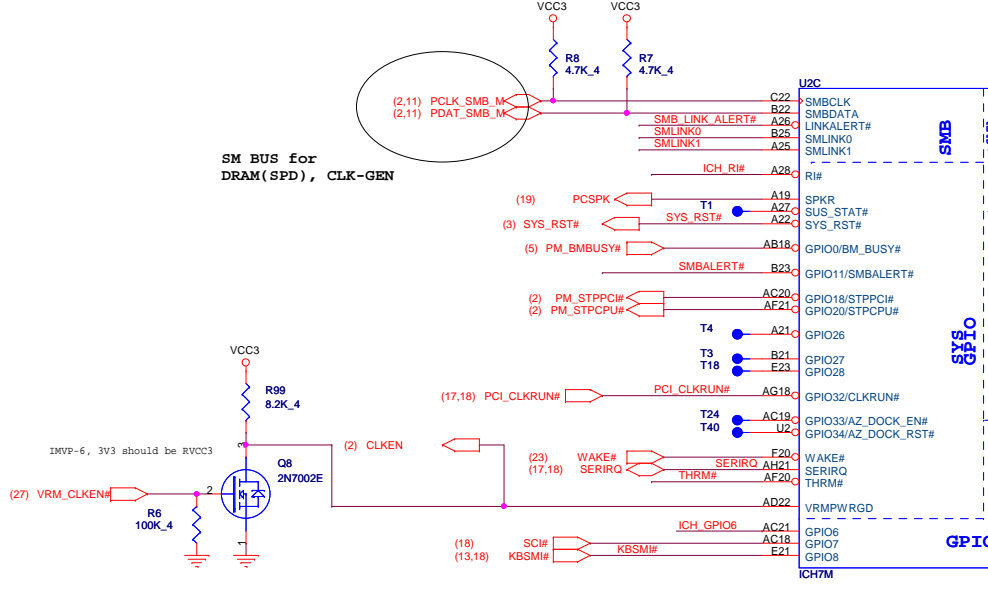

(23)

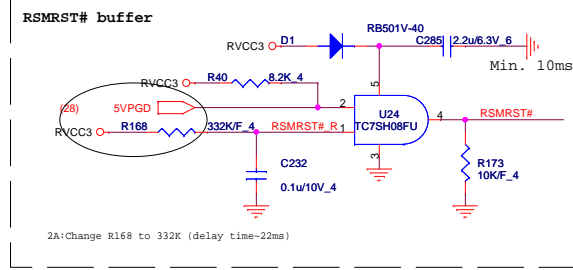
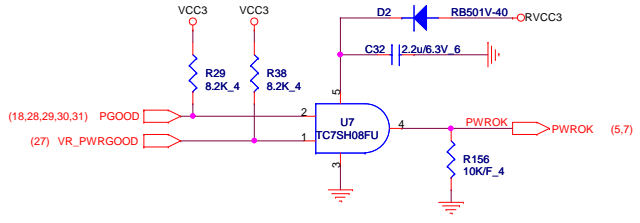
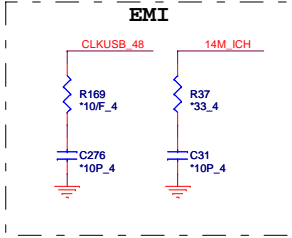
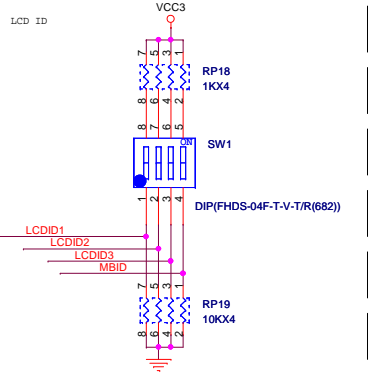
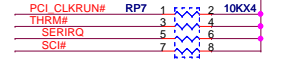
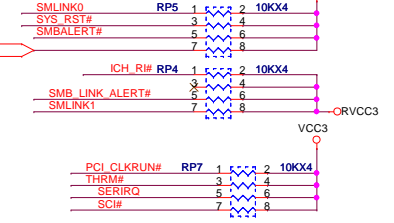

1. Level 1 Environment-related Substances Should NEVER be Used.
2. Purchase ink, paint, wire rods, and Molding resins only from the business Partners that Sony approves as Green Partners.

QUANTA COMPUTER

Title: **ICH9-M GPIO(3of 4)**

Size: _____ Document Number: **SY2 MB** Rev: **2C**

Date: **Friday, April 10, 2009** Sheet: **14** of **36**

Mini PCI-E Card--W-LAN

WoW NOT supported

Wi-LAN ripple(3.3V, 1.5V) <100mV

2A: Change D10 to RB501V-40

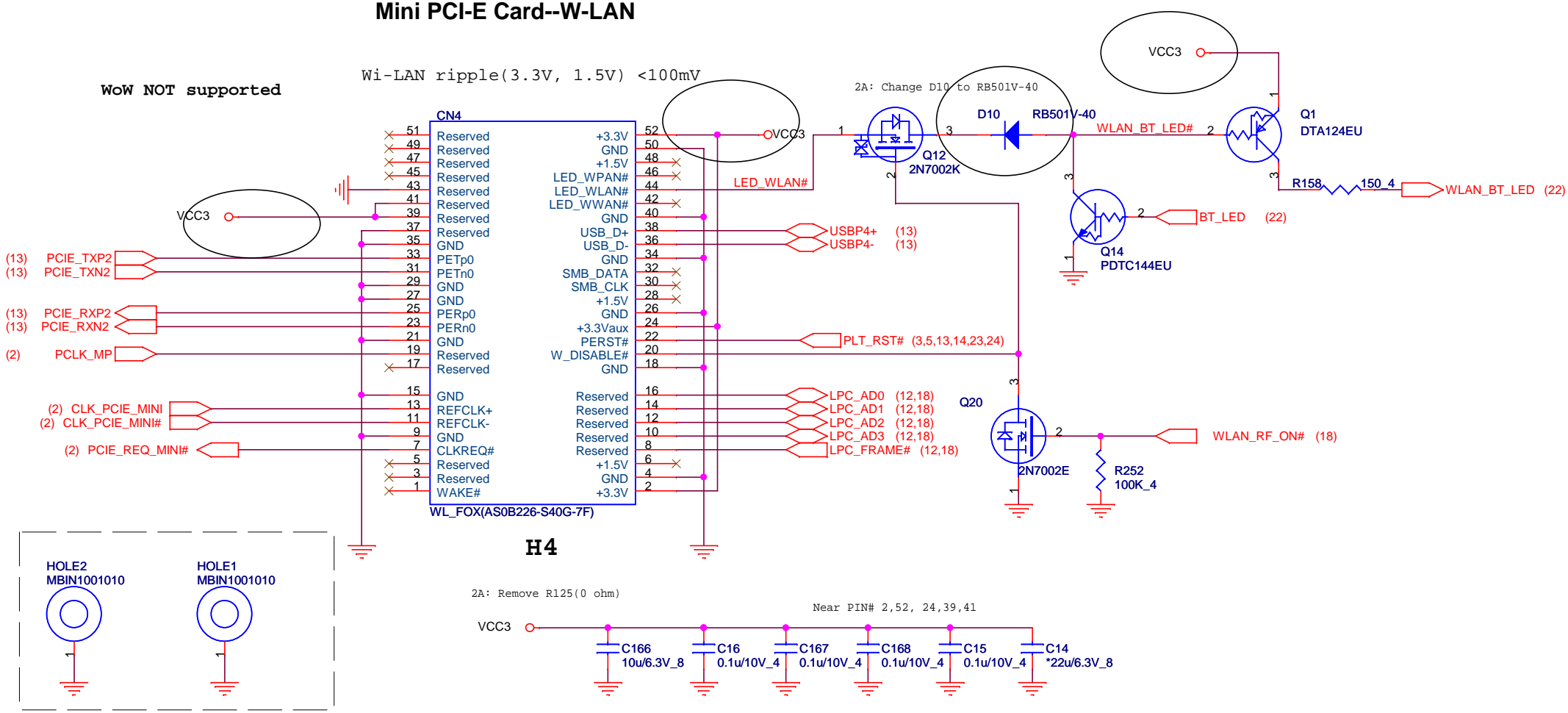

H4

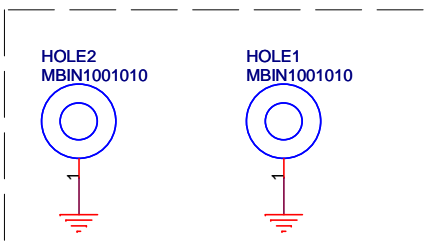

1.Level 1 Environment-related Substances Should NEVER be Used.
 2.Purchase ink, paint, wire rods, and Molding resins only from the business Partners that Sony approves as Green Partners.

		QUANTA COMPUTER
Title		
WLAN & BT		
Size	Document Number	Rev
Custom	SY2 MB	2C
Date:	Friday, April 10, 2009	Sheet 16 of 36

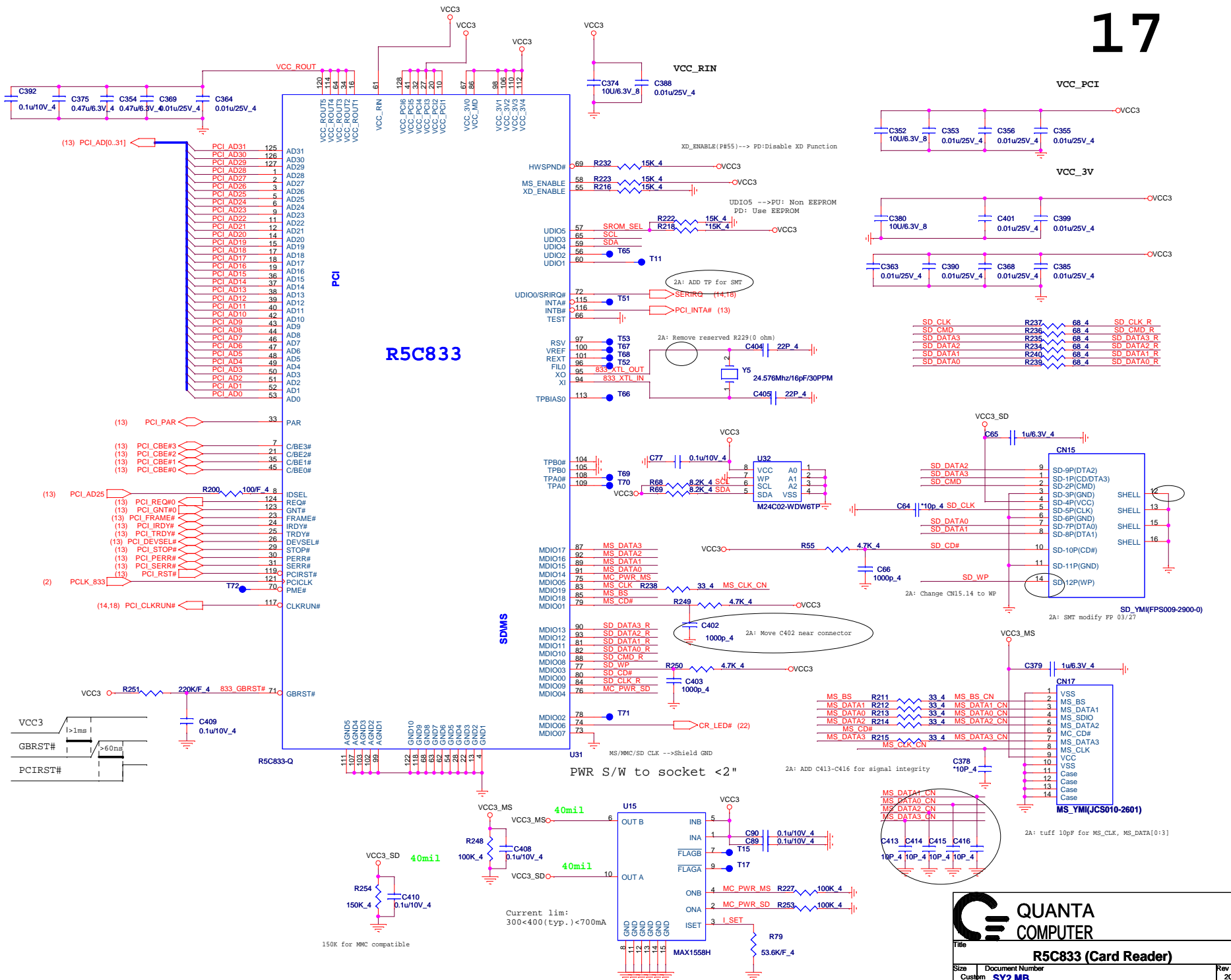

R5C833

QUANTA COMPUTER

Title: **R5C833 (Card Reader)**

Size: Document Number

Custom: **SY2 MB**

Date: Friday, April 10, 2009

Sheet: 17 of 36

Rev: 2C

1.Level 1 Environment-related Substances Should NEVER be Used.
 2.Purchase ink, paint, wire rods, and Molding resins only from the business Partners that Sony approves as Green Partners.

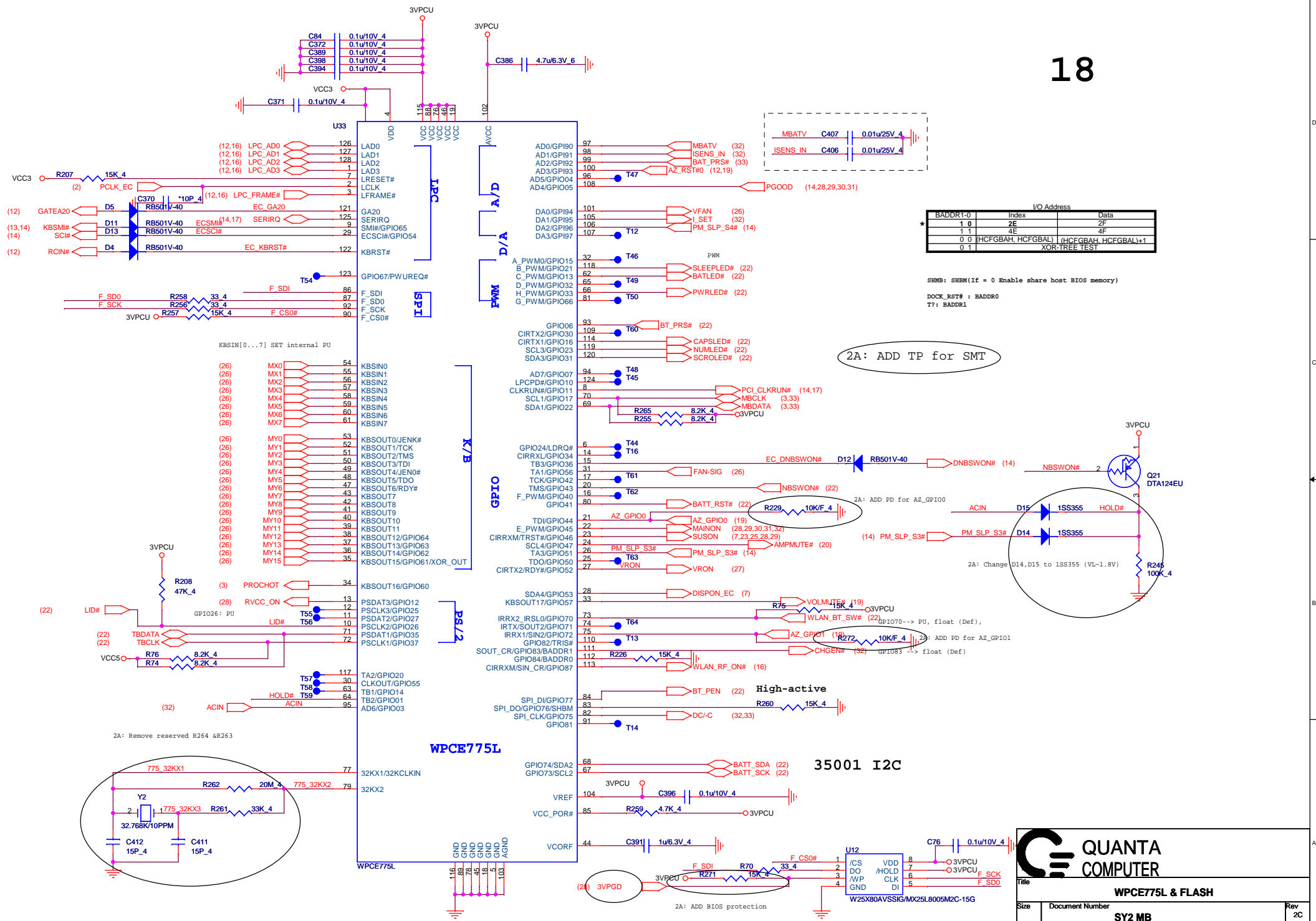

I/O Address			
BADDR1-0	Index	Data	
1 0	2E	2F	
1 1	4E	4F	
0 0	[HCFGBAH, HCFGBALL] [HCFGBAH, HCFGBAL+1 XOR-TREE TEST]		
0 1			

SHMB: SHBM (If = 0 Enable share host BIOS memory)
DOCK_RST#: BADDR0
T?: BADDR1

2A: ADD TP for SMT

2A: ADD PD for AZ_GPIO0

2A: Change D14, D15 to 1SS355 (VL-1.8V)

2A: Remove reserved R264 & R263

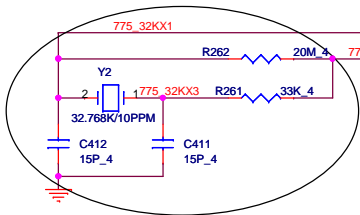

1. Level 1 Environment-related Substances Should NEVER be Used.
2. Purchase ink, paint, wire rods, and Welding resins only from the business Partners that Sony approves as Green Partners.

QUANTA COMPUTER

Title: **WPCE775L & FLASH**

Size	Document Number	Rev
	SY2 MB	2C

Date: Friday, April 10, 2009 Sheet 18 of 36

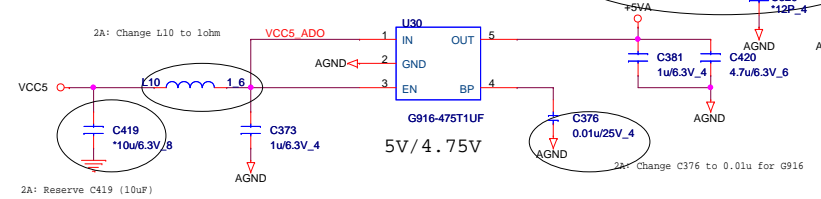
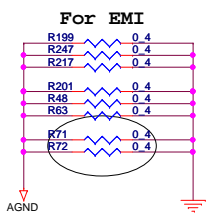
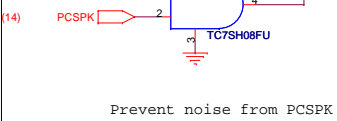
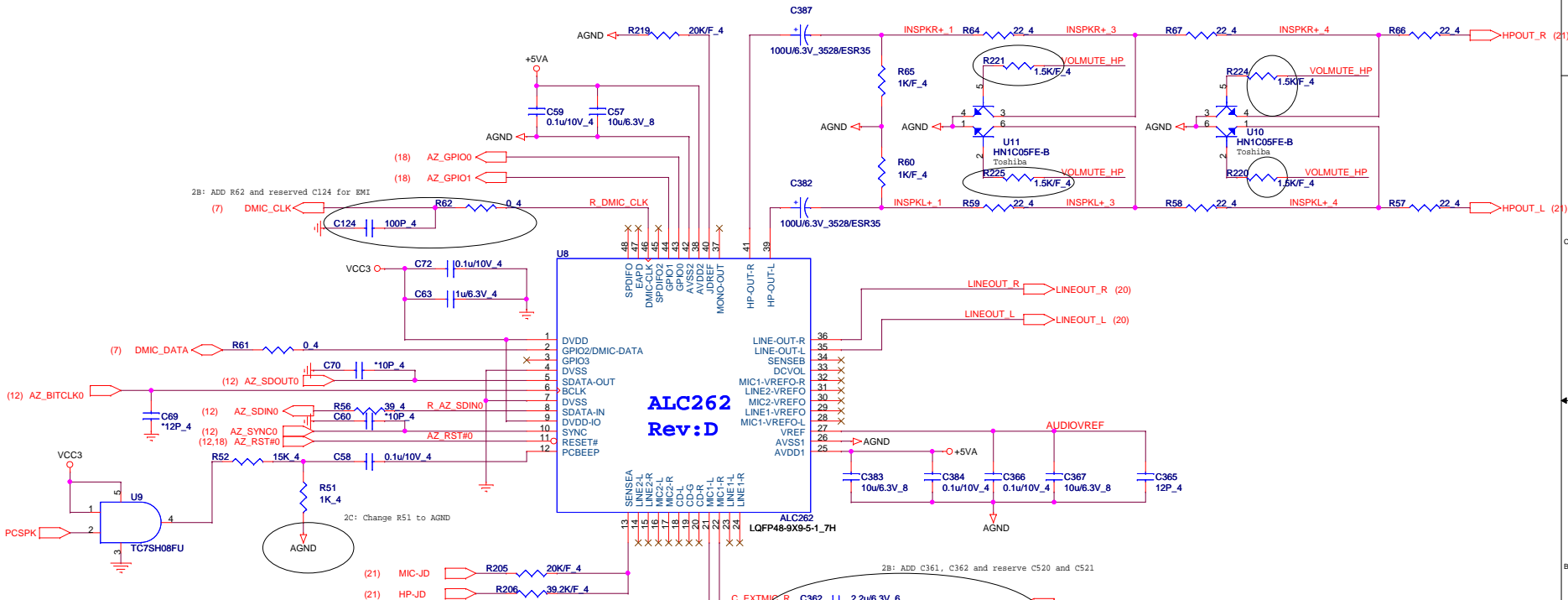
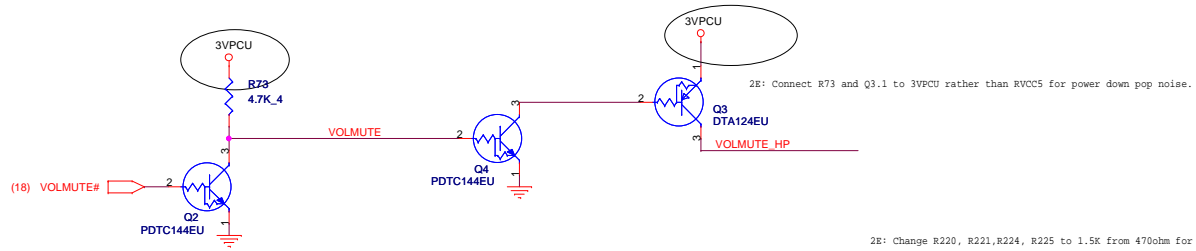

1.Level 1 Environment-related Substances Should NEVER be Used.
 2.Purchase ink, paint, wire rods, and Molding resins only from the business Partners that Sony approves as Green Partners.

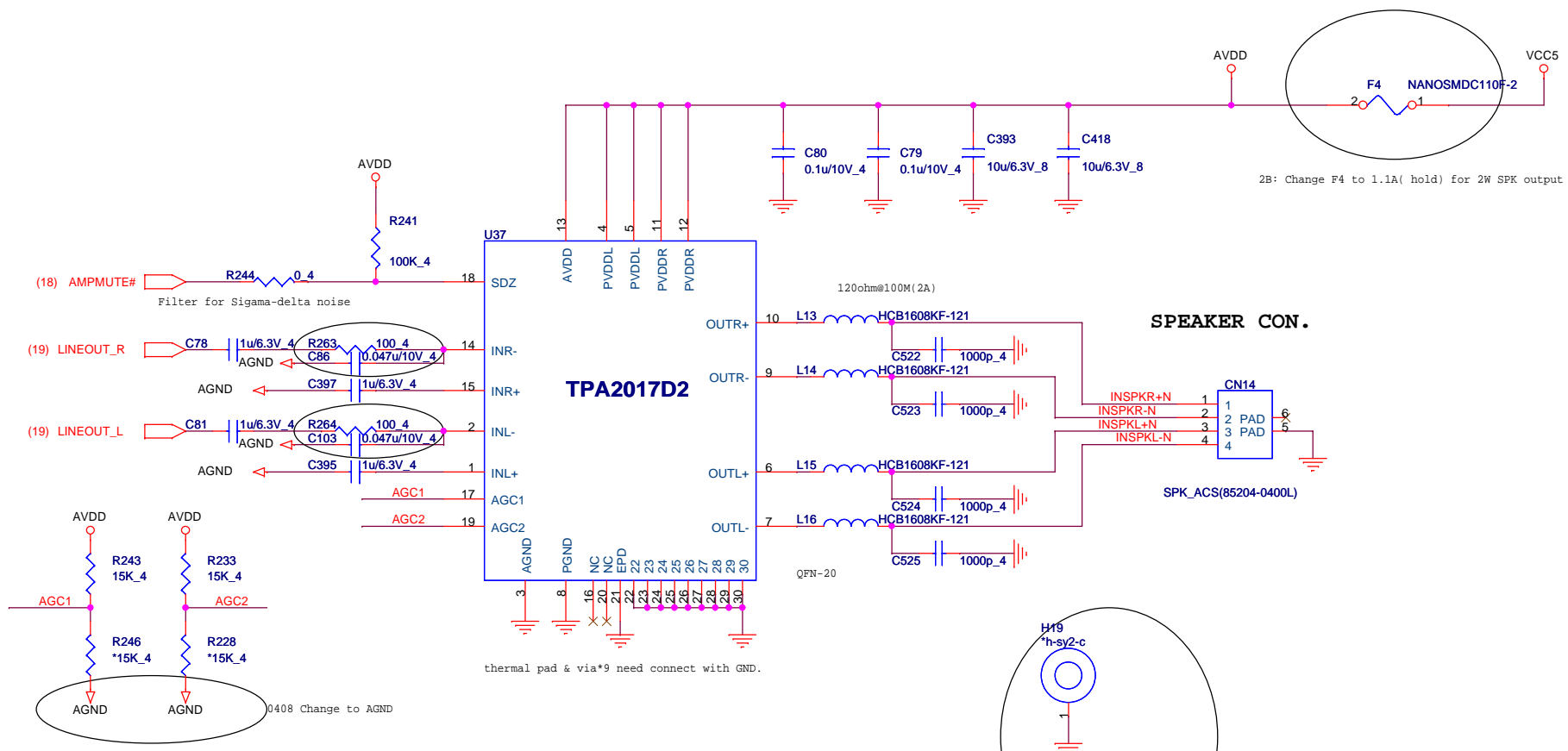

2B: Change F4 to 1.1A(hold) for 2W SPK output

SPEAKER CON.

SPK_ACS(85204-0400L)

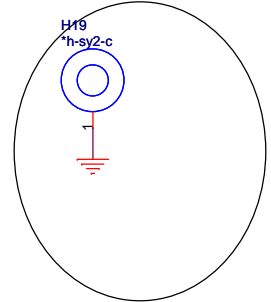

AGC1	AGC2	Function
0	0	AGC Function Disable
0	1	AGC, LIMITER Function Enable
1	0	AGC, LIMITER, Compression Function Enable
1	1	AGC, LIMITER, Compression and Noise Gate Function Enable

1.Level 1 Environment-related Substances Should NEVER be Used.
 2.Purchase ink, paint, wire rods, and Molding resins only from the business Partners that Sony approves as Green Partners.

QUANTA COMPUTER

Title **AMP TPA2017D2**

Size Custom	Document Number SY2 MB	Rev 2C
-------------	-------------------------------	--------

Date: Friday, April 10, 2009 Sheet 20 of 36

MIC Pre-AMP

2A: Change MIC- AMP circuit

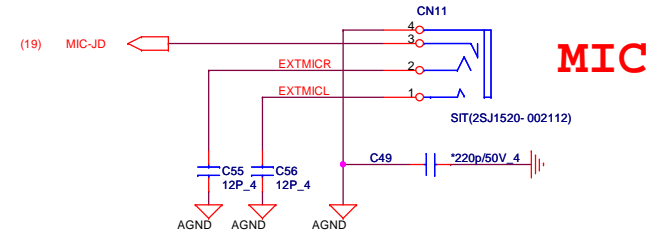
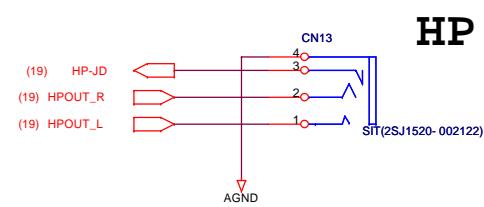
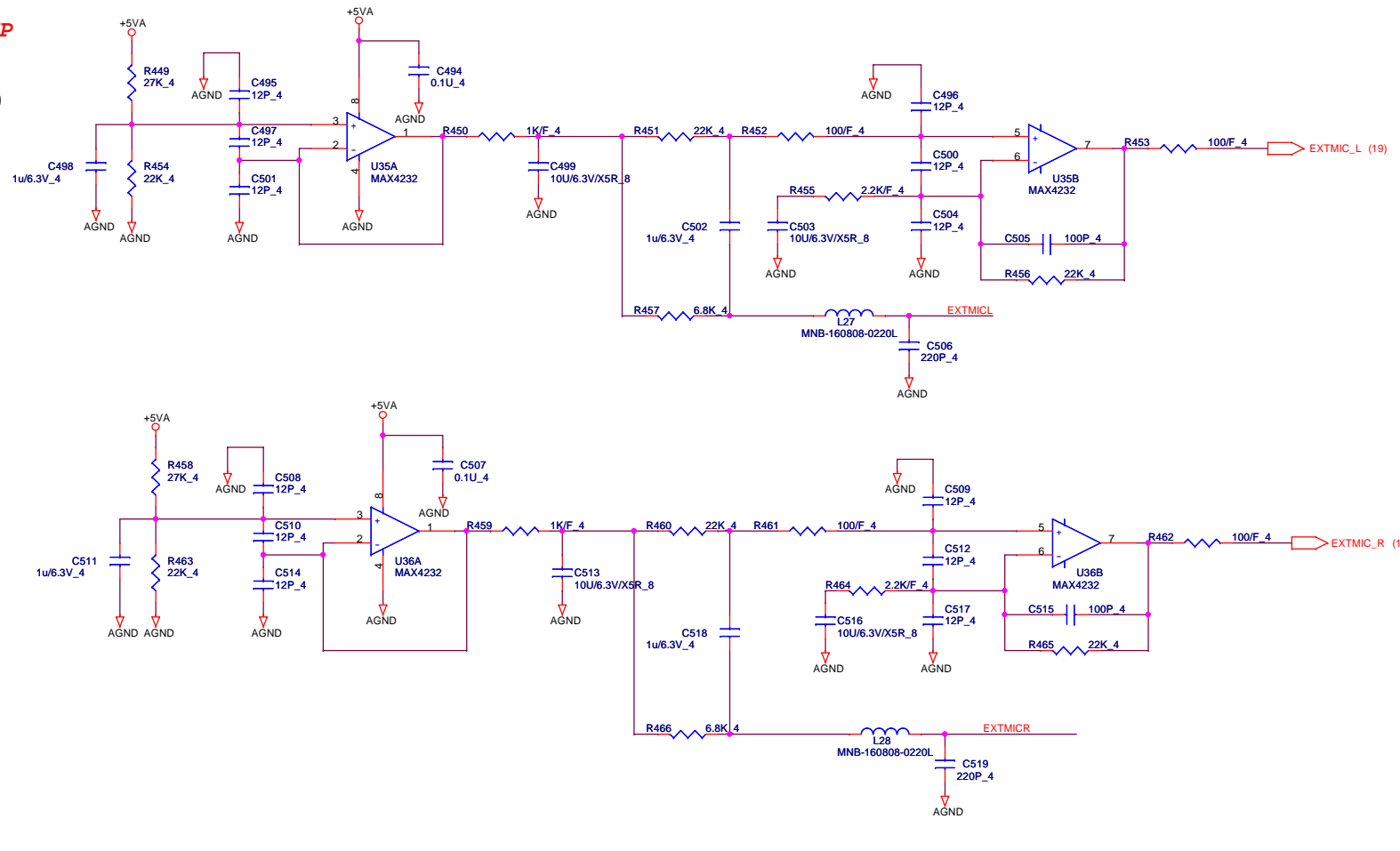

QUANTA COMPUTER

Title: **AUDIO JACK & MIC PRE-AMP**

Size Custom	Document Number SY2 MB	Rev 2C
Date: Friday, April 10, 2009	Sheet 21 of 36	

1.Level 1 Environment-related Substances should NEVER be Used.
 2.Purchase ink, paint, wire rods, and Molding resins only from the business Partners that Sony approves as Green Partners.

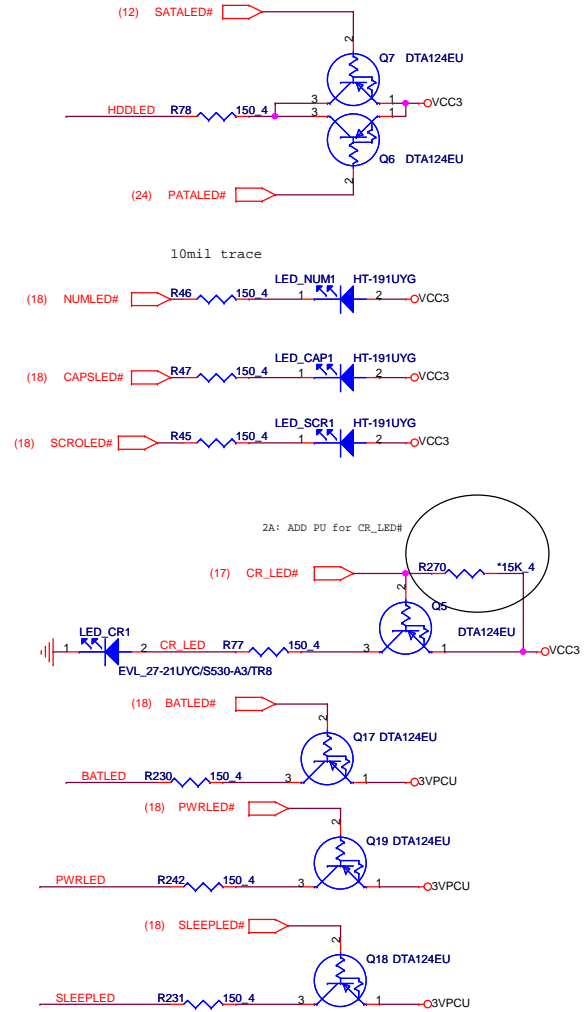
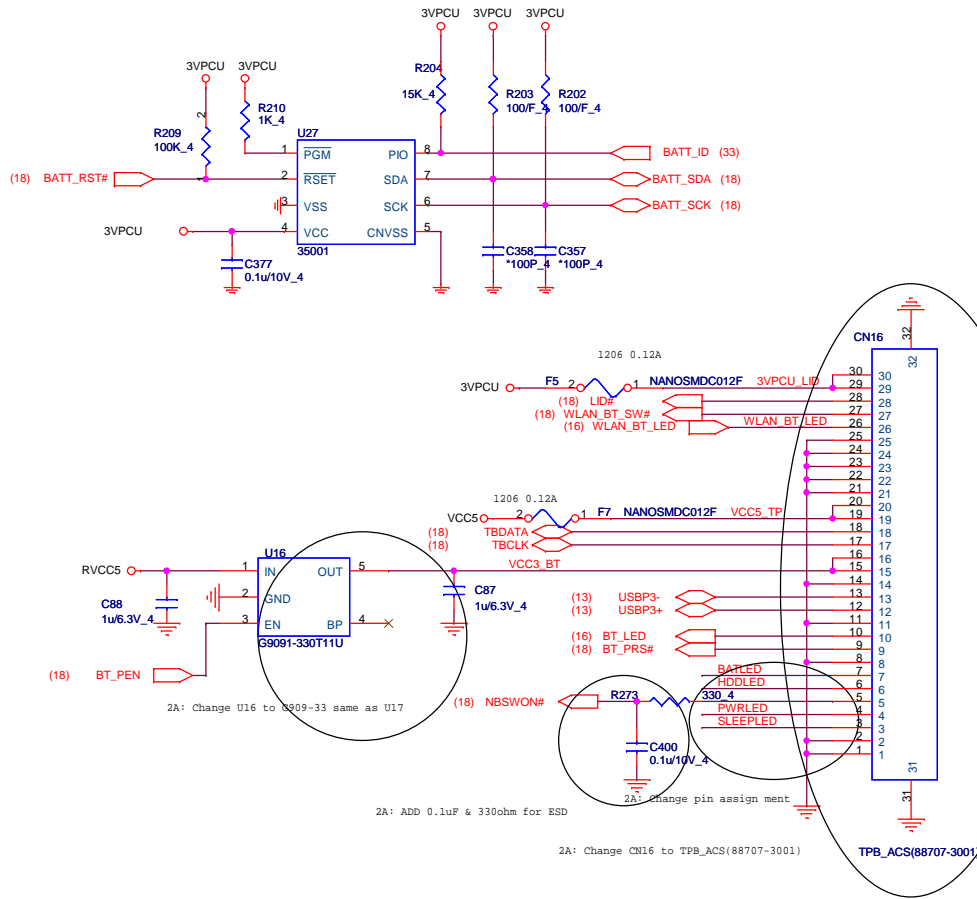

"Power, S0 (green), S3 (Umber flash), S4 (off), S5 (off)
 "Charger status in Umber color, Charge (on), Error (flash quickly)
 "HDD status, LED in yellow color
 "Caps Lock/Num Lock/Scroll Lock in green color
 "Wireless status in green color
 "Memory Stick Duo/SD Card status in yellow color
 "Camera status in green color (on Camera module)

1.Level 1 Environment-related Substances Should NEVER be Used.
 2.Purchase ink, paint, wire rods, and Molding resins only from the business Partners that Sony approves as Green Partners.

QUANTA COMPUTER		
Title 35001/LED/Button/TP/BT		
Size Custom	Document Number SY2 MB	Rev 2C
Date: Friday, April 10, 2009	Sheet 22 of 36	

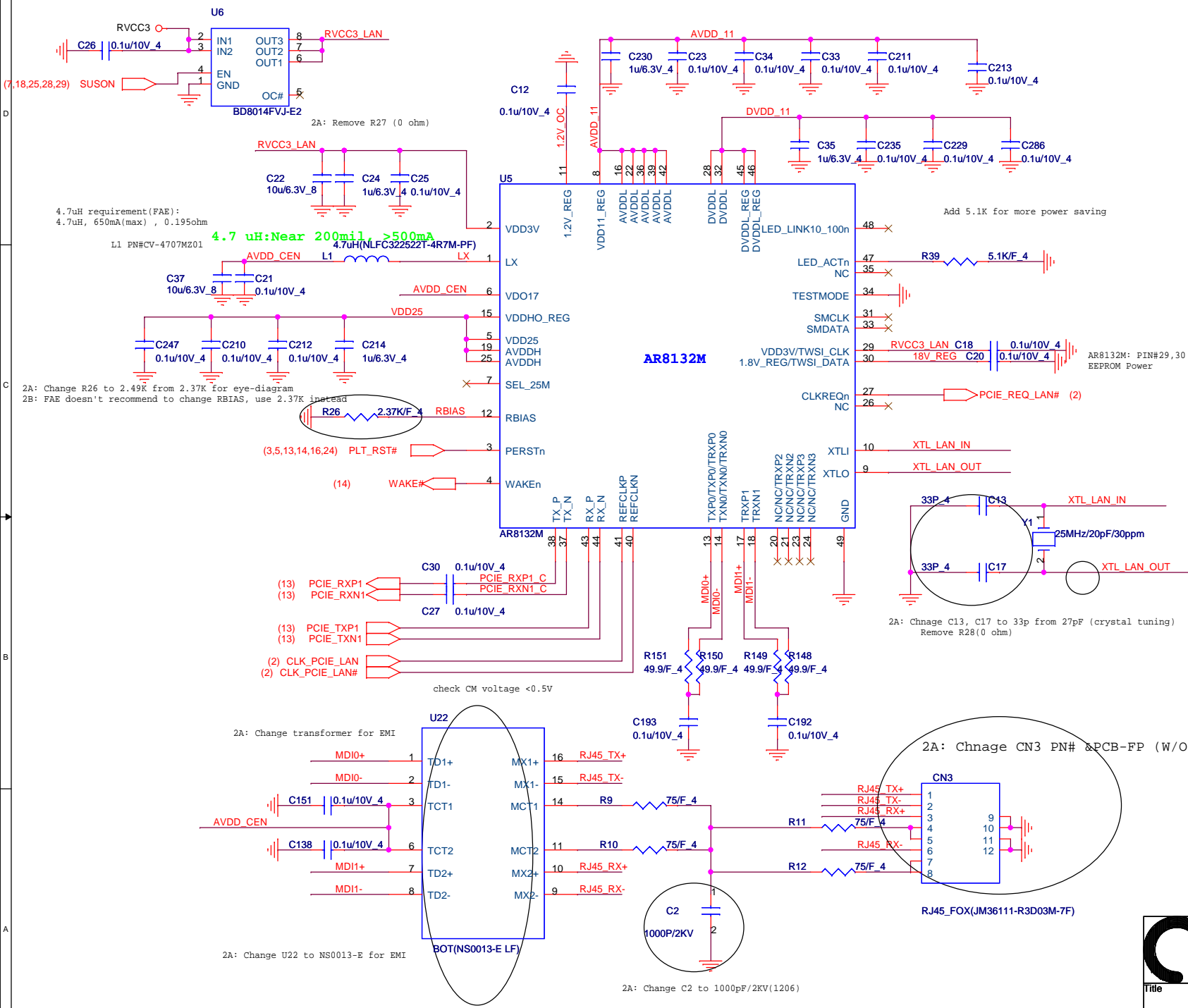

4.7uH requirement (FAE):
4.7uH, 650mA(max), 0.195ohm

L1 PN#CV-4707M201
4.7 uH: Near 200mil, >500mA
4.7uH(NLFC322522T-4R7M-PF)

2A: Change R26 to 2.49K from 2.37K for eye-diagram
2B: FAE doesn't recommend to change RBIAS, use 2.37K instead

Add 5.1K for more power saving

AR8132M: PIN#29,30
EEPROM Power

2A: Chnage C13, C17 to 33p from 27pF (crystal tuning)
Remove R28(0 ohm)

check CM voltage <0.5V

2A: Change transformer for EMI

2A: Chnage CN3 PN# & PCB-FP (W/O LED)

2A: Change U22 to NS0013-B for EMI

2A: Change C2 to 1000pF/2KV(1206)

**QUANTA
COMPUTER**

Title: **LAN AR8132M**

Size	Document Number	Rev
Custom	SY2 MB	2C

Date: Friday, April 10, 2009 Sheet 23 of 36

1. Level 1 Environment-related Substances Should NEVER be Used.
2. Purchase ink, paint, wire rods, and Molding resins only from the business Partners that Sony approves as Green Partners.

2.5 inch SATA HDD

24

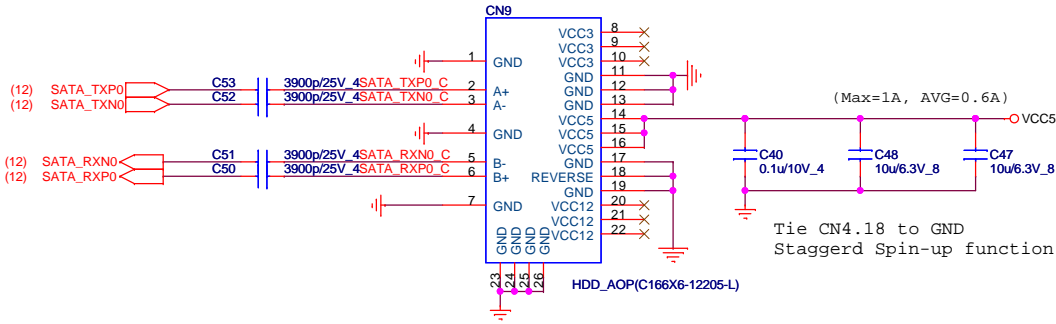

PATA SSD(16GB)

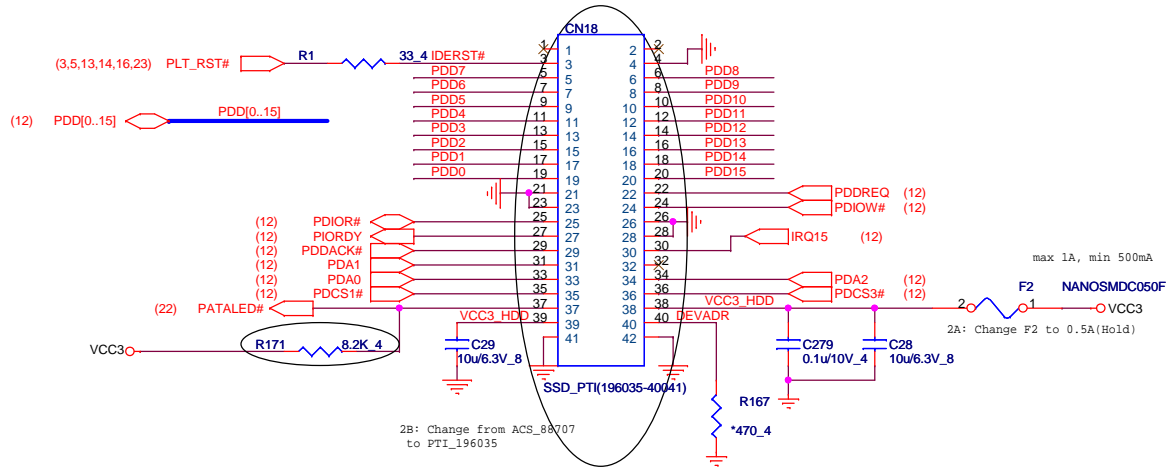

1.Level 1 Environment-related Substances should NEVER be Used.
 2.Purchase ink, paint, wire rods, and Molding resins only from the business Partners that Sony approves as Green Partners.



**QUANTA
COMPUTER**

Title: **HDD**

Size	Document Number	Rev
Custom	SY2 MB	2C

Date: Friday, April 10, 2009 Sheet 24 of 36

USB Power and Over current

Current limit =1.5~2A

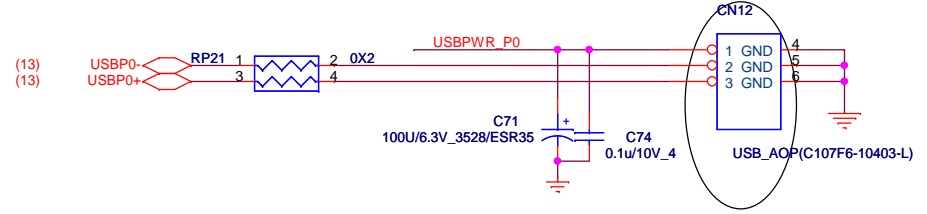
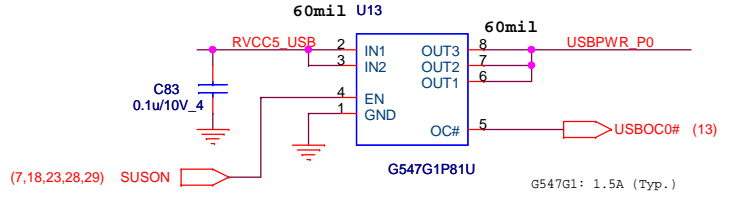

2A: Change CN10, CN12 PN# (gray color)

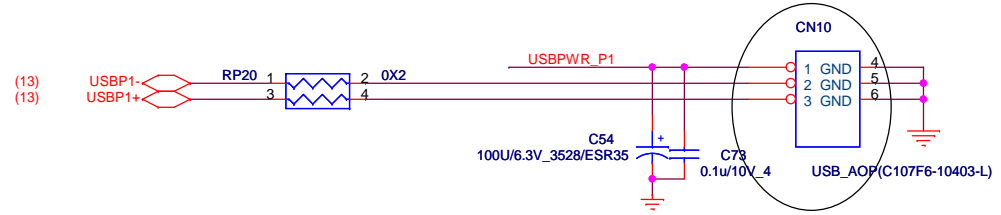
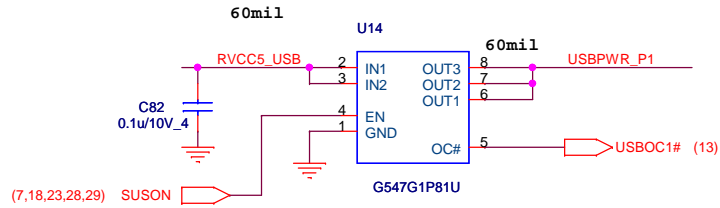

- 1.Level 1 Environment-related Substances Should NEVER be Used.
- 2.Purchase ink, paint, wire rods, and Molding resins only from the business Partners that Sony approves as Green Partners.

		QUANTA COMPUTER	
Title			
USB			
Size	Document Number	Rev	
Custom	SY2 MB	2C	
Date: Friday, April 10, 2009		Sheet	25 of 36

INT. KEYBOARD

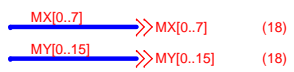
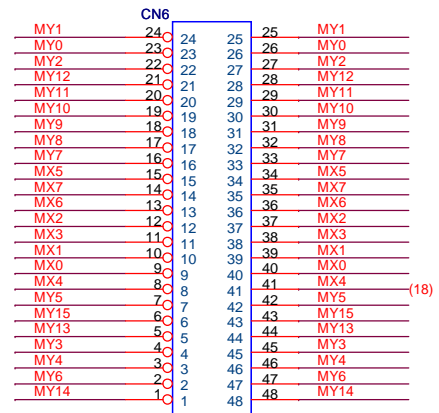
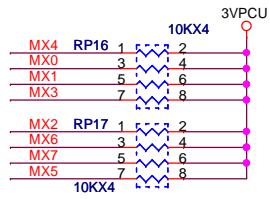

KB_ACS(88483-2401)

check internal PU

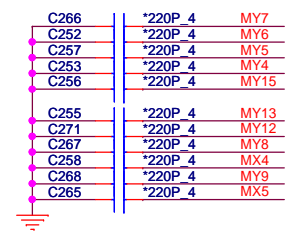
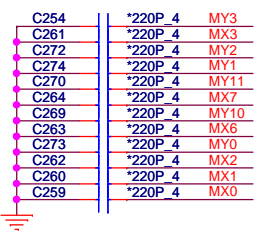

FAN Circuit

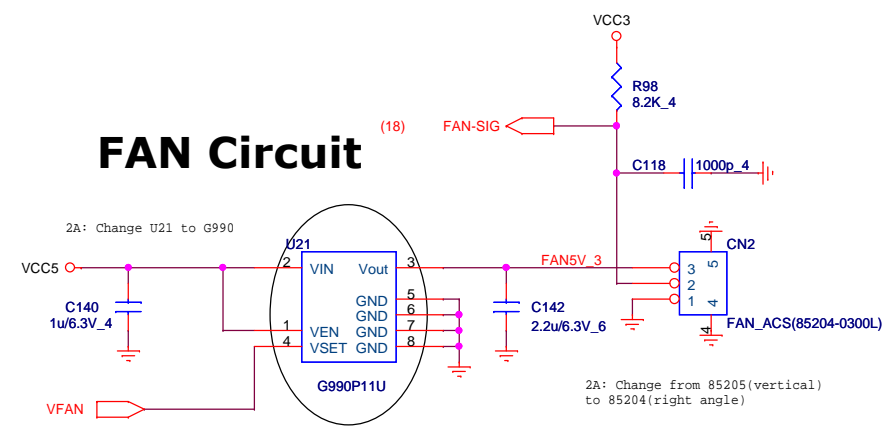

2A: Change U21 to G990

2A: Change from 85205(vertical) to 85204(right angle)

1.Level 1 Environment-related Substances Should NEVER be Used.
2.Purchase ink, paint, wire rods, and Molding resins only from the business Partners that Sony approves as Green Partners.

**QUANTA
COMPUTER**

Title: **K/B, FAN, T/P**

Size	Document Number	Rev
Custom	SY2 MB	2C

Date: Friday, April 10, 2009 Sheet 26 of 36

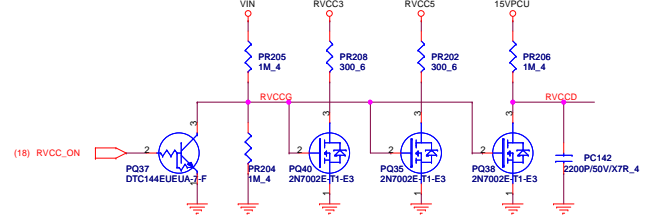
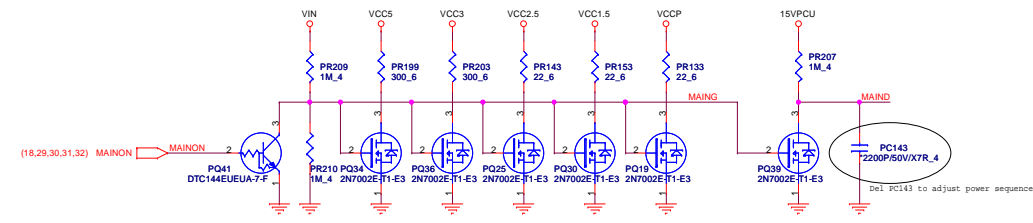
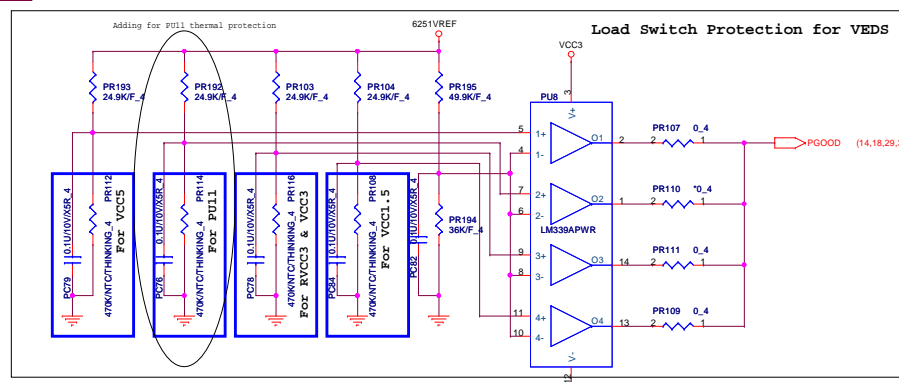
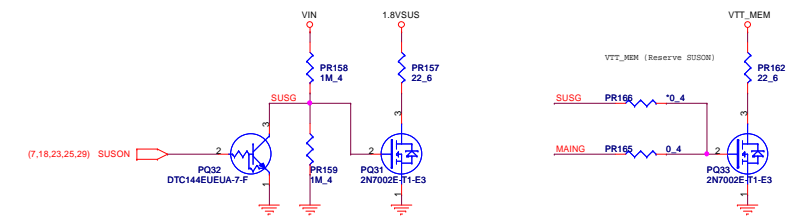
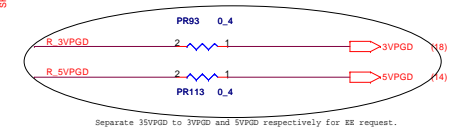
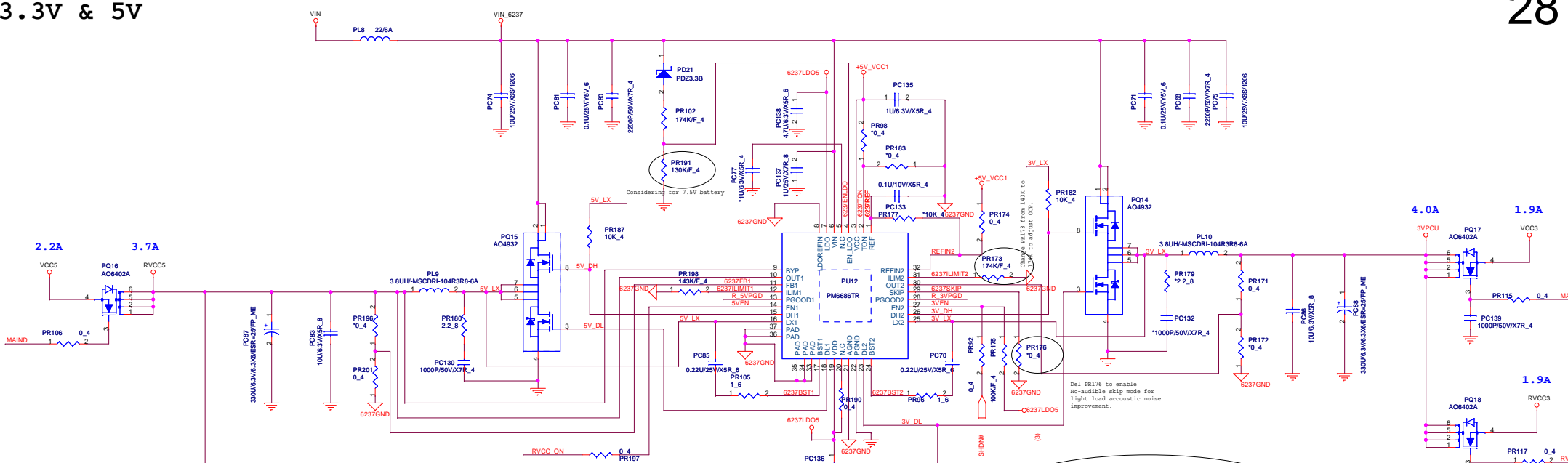

1.8VSUS & VTT_MEM

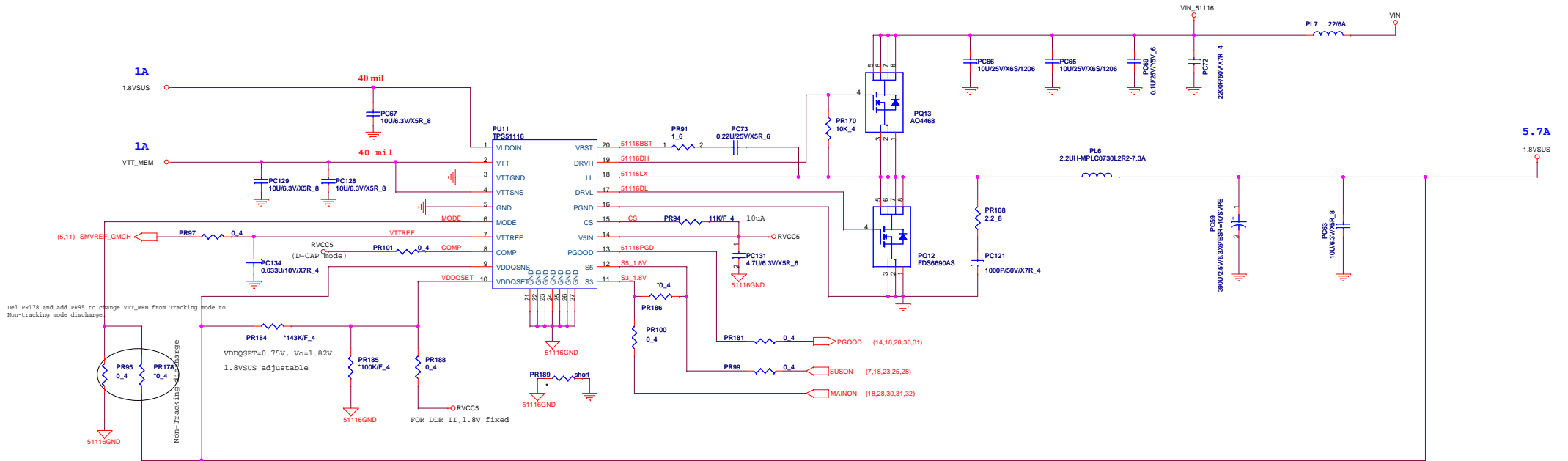

Del PR178 and add PR55 to change VTT_MEM from Tracking mode to Non-tracking mode discharge

MODE	DISCHARGE MODE
+5V	No discharge
+1.8V	Tracking discharge
GND	Non-tracking discharge

VDDQSET	VDDQ(V)	VITREF & VTT	NOTE
GND	2.5 fixed	VDDQSNS/2	DDR
5V	1.8 fixed	VDDQSNS/2	DDR2
FB-Resistor	Adjustable	VDDQSNS/2	1.5V<VDDQ<3V

VTT = VITREF = VDDQSNS/2 = 0.9V

STATE	S3	S5	1.8VSUS	VITREF	VTT
S0	1	1	on	on	on
S3	0	1	on	on	off
S4/S5	0	0	off	off	off

1.Level 1 Environment-related Substances should NEVER be Used.
2.Purchase Ink, paint, wire rods, and Soldering resins only from the business Partners that Sony approves as Green Partners.



**QUANTA
COMPUTER**

Size	Document Number	Rev
SY2 MB	SY2 MB	ZC
Date	Friday, April 10, 2009	Sheet 29 of 36

VCCP

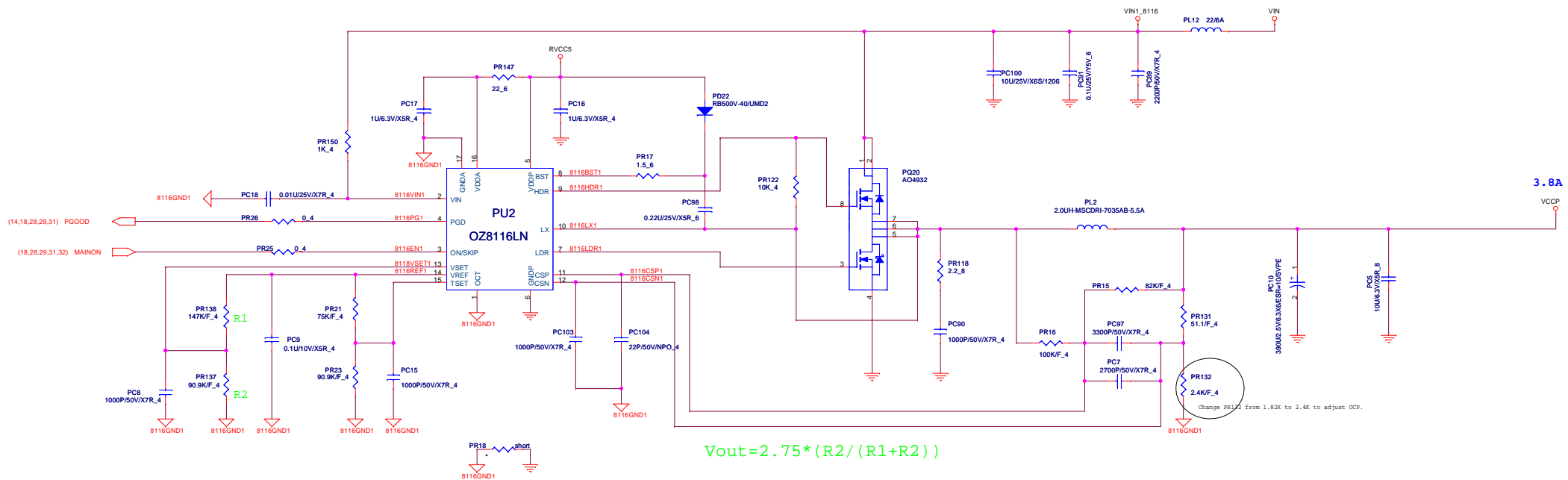

1. Level 1 Environment-related Substances Should NEVER be Used.
 2. Purchase ink, paint, wire rods, and Molding resins only from the business Partners that Sony approves as Green Partners.

VCC1.5

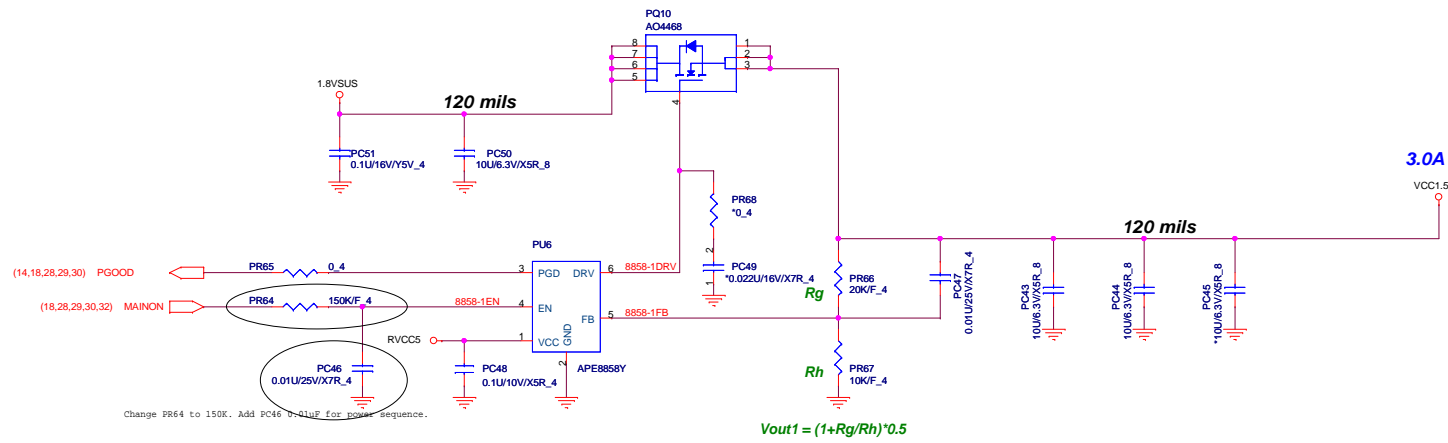

VCC2.5

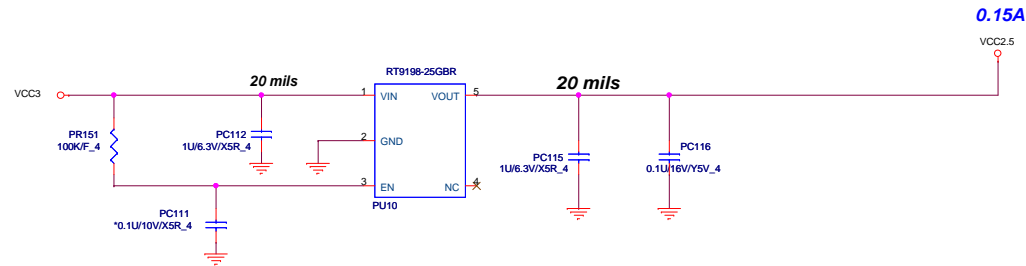

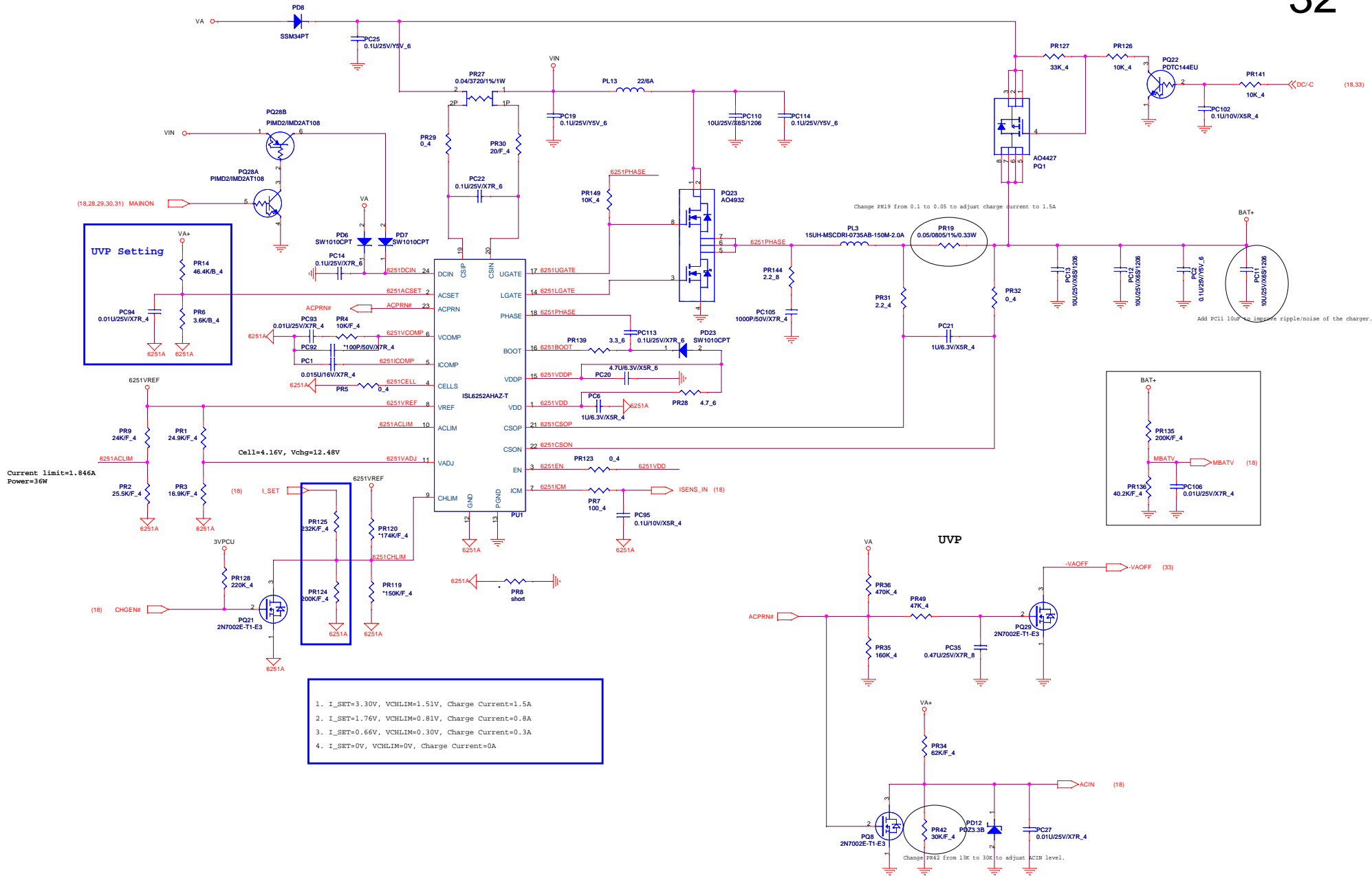

1.Level 1 Environment-related Substances should NEVER be Used.
 2.Purchase ink, paint, wire rods, and Molding resins only from the business Partners that Sony approves as Green Partners.

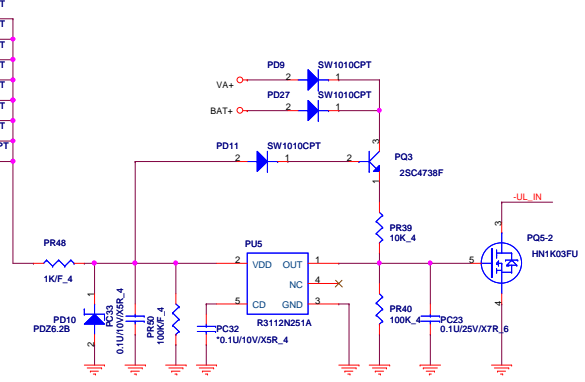
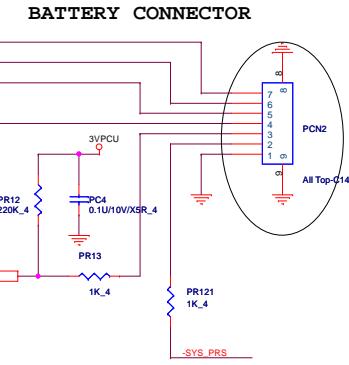
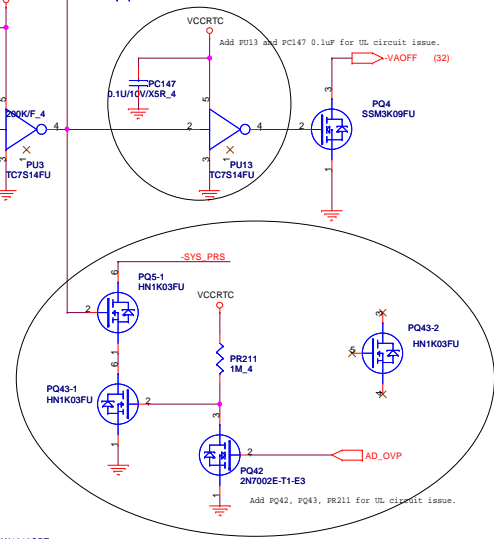
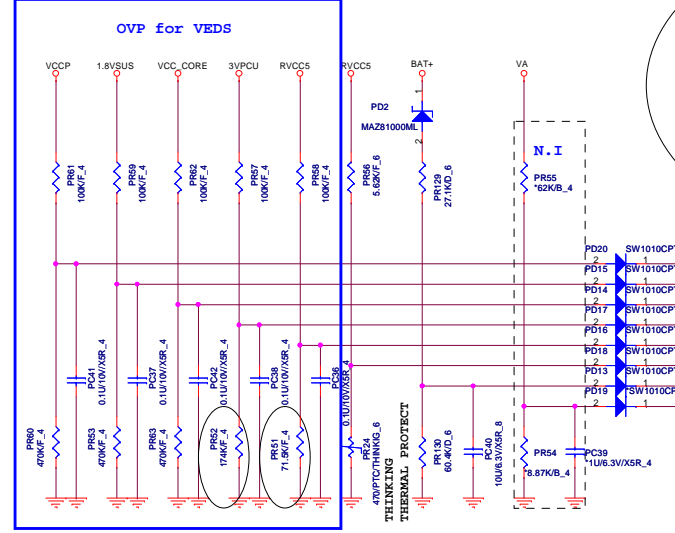
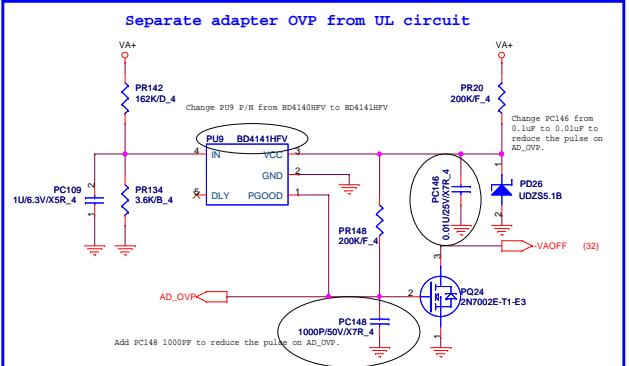
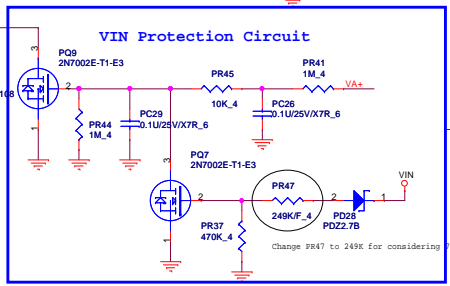
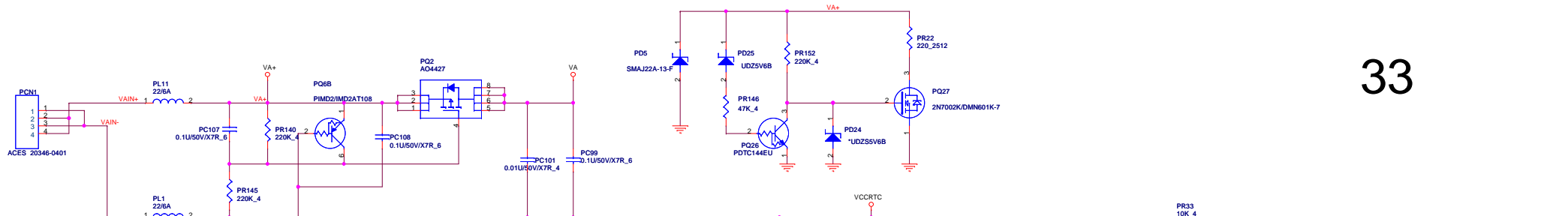

QUANTA COMPUTER

Size	Document Number	Rev
512 MB	512 MB	2C
Date: Friday, April 10, 2009	Sheet	33 of 36

1. Level 1 Environment-related Substances Should NEVER be Used.
2. Purchase ink, paint, wire rods, and Molding resins only from the business Partners that Sony approves as Green Partners.

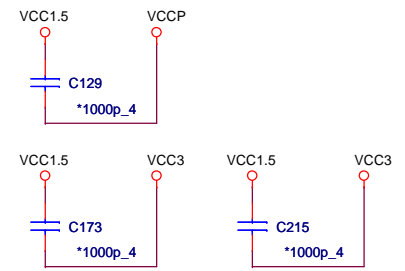
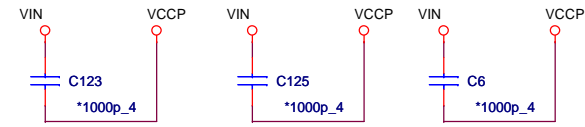
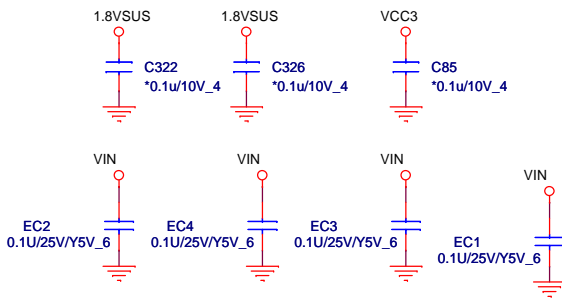
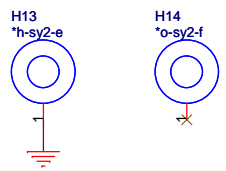
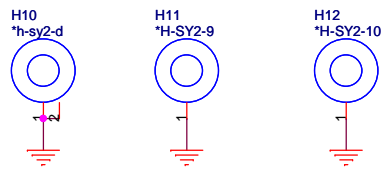
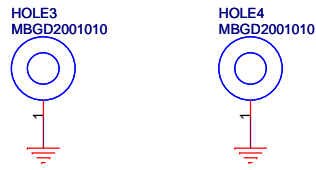
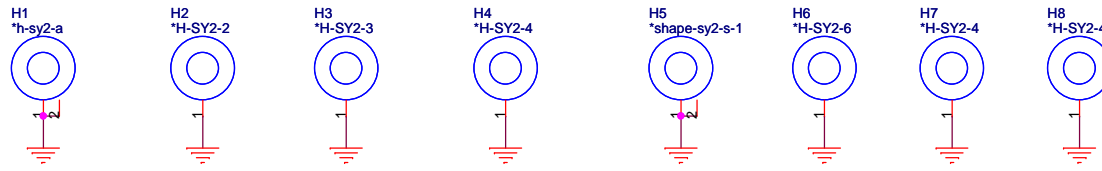

- 1.Level 1 Environment-related Substances should NEVER be Used.
- 2.Purchase ink, paint, wire rods, and Molding resins only from the business Partners that Sony approves as Green Partners.

 QUANTA COMPUTER		
Title Screw Hole		
Size Custom	Document Number SY2 MB	Rev 2C
Date: Friday, April 10, 2009		Sheet 34 of 36

SY2 Power-up Block

SY2 Power-up Sequencing

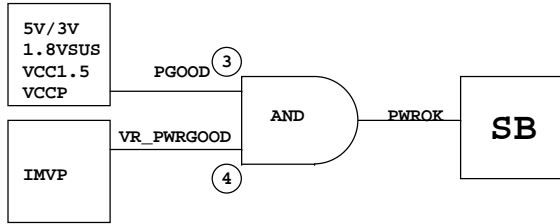
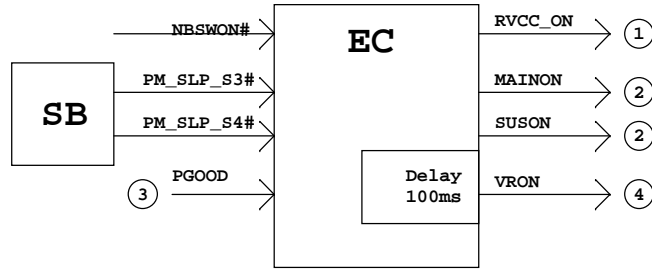

Power State Table									
AC Mode	S0	S3	S4	S5	BATT	S0	S3	S4	S5
6237LDO5	ON	ON	ON	ON	6237LDO5	ON	ON	ON	ON
3VPCU	ON	ON	ON	ON	3VPCU	ON	ON	ON	ON
RVCC5	ON	ON	ON	OFF	RVCC5	ON	ON	OFF	OFF
RVCC3	ON	ON	ON	OFF	RVCC3	ON	ON	OFF	OFF
1.8VSUS	ON	ON	OFF	OFF	1.8VSUS	ON	ON	OFF	OFF
VCC5	ON	OFF	OFF	OFF	VCC5	ON	OFF	OFF	OFF
VCC3	ON	OFF	OFF	OFF	VCC3	ON	OFF	OFF	OFF
VCC2.5	ON	OFF	OFF	OFF	VCC2.5	ON	OFF	OFF	OFF
VCCP	ON	OFF	OFF	OFF	VCCP	ON	OFF	OFF	OFF
VCC_CORE	ON	OFF	OFF	OFF	VCC_CORE	ON	OFF	OFF	OFF

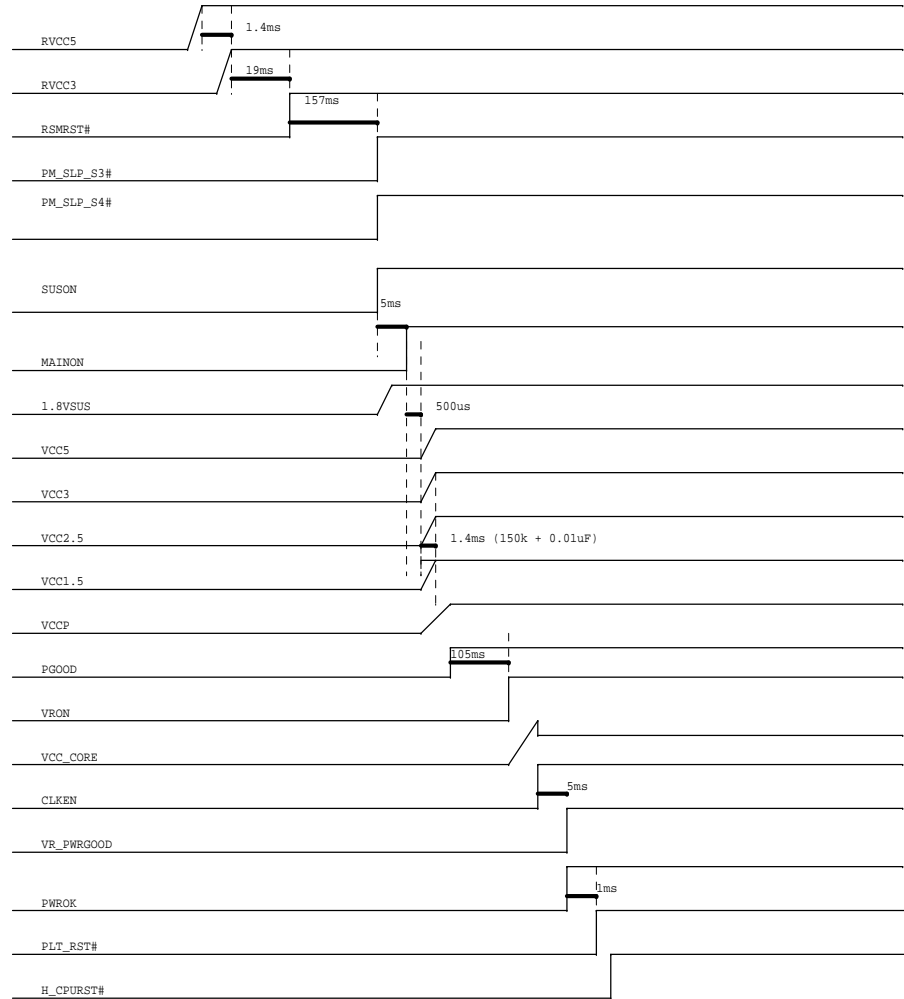

QUANTA COMPUTER

Title: **Power-up Sequence**

Size B | Document Number: **SY2 MB** | Rev 2C

Date: Friday, April 10, 2009 | Sheet 35 of 36

1219:(1A)
 First release
 1231:(1B)
 -P.2
 Modify CLK_FSC, CLK_FSB strapping circuit to CLK-GEN
 Change PCI CLK damping to 22ohm (impedance matching)
 -P.9
 Reserve one 220uF for 1.8VSUS to 945GSE
 -P.10
 Change CRT-SCK, CRT-SDA PU to 2.2K for compatibility
 Change DDC2BC, DDC2BD PU to 3.9K for compatibility
 Change VCC5CRT circuit using fuse and Schottky
 -P.14
 Modify RSMRST# buffer circuit
 -P.17
 Change R5C833 GBRST# circuit
 -P.20
 Reserve 0 ohm to AMP R/L_in
 Change AMP to APA2031
 -P.21
 Change Fuse to 0.12A for Hall sensor
 Change fuse to 0.12A for TP/B

0325(2A)
 -P.2
 Remove reserved 0ohm (R95,R106,R105)
 -P7
 Change C96 to 1uF for abnormal operation
 Reserve L11 and C126 for EMI
 -P9
 Remove reserved L3-6, C3
 Remove unnecessary C105
 -P10
 Change F3 to 0.25A ((hold)
 Change CN7 PCB-FP
 -P14
 Change R168 to 332K (delay time-22ms)
 Remove reserved SUSCLK
 -P15
 Remove reserved L2
 -P16
 Change D10 to RB501V-40
 Remove reserved R125(0 ohm)
 -P17
 ADD C413-C416 for signal integrity
 Change CN15.14 to WP (mistake)
 Remove reserved R229 (0 ohm)
 Move C402 near CN17
 -P18
 ADD BIOS protection circuit to
 ADD PD for AZ_GPIO0 and AZ_GPIO1
 Change D14,D15 to 1S8355 (VL-1.8V)
 Remove reserved R263, R264
 -P19
 ADD L12 and reserved C124 for EMI
 Change C376 to 0.01uF for G916
 Change L10 to 1ohm
 Add reserved C419 (10uF) for VCC5
 -P20
 Change C78,C81, C395, C397 to 0.47uF
 for better Low freq response.
 -P21
 Change MIC- PRAMP circuit
 -P22
 Change U16 to G909-33 same as U17
 ADD R237 and C400 for ESD
 -P23
 Change R26 to 2.49K for better PCIE eye
 Change U6 to BD8014
 Remove reserved R27 (0ohm)
 Change C13 and C17 to 33pF (crystal tuning)
 Change C2 to 1000p/2KV (1206 size)
 Change U22 to NS013-E for EMI
 -P24
 Change F2 to 0.5A(Hold)
 -P26
 Change U21 to GMT G990
 -P28
 Remove PC143 for power up sequence
 -P29
 Mount PR96 and un-stuff PR178 for discharge mode
 -P31
 Cange PR64/PC46 to 150K/ 0.1u for power up sequence

0403 (2B)
 -P4
 Remove reserved C5
 -P7
 Change CN1 pin definition
 -P12
 Reserve R27 (0 ohm)
 -P19
 ADD C124 with 100pF for DMIC_CLK
 ADD C361, C362 and reserve C520 and C521
 -P20
 Change F4 to 1.1A(hold) for 2W SPK
 Change U34(AMP) to TPA2016D2
 -P24
 Change SSD FFC CNN to easy on type.
 -P.27
 Remove jumper PG3.
 Remove PC55 due to PC55 is reserved only.
 -P.28
 Remove jumper PG5, PG6
 -P17
 Change PR173 from 143K to 174K to adjust OCP.
 Del PR176 to enable No-audible skip mode for light load acoustic
 noise improvement.
 Del PC143 to adjust power sequence.
 Separate 35VPGD to 3VPGD and 5VPGD respectively for EE request.
 -P.29
 Remove jumper PG4, PG8.
 Del PR178 and add PR95 to change VTT_MEM from Tracking mode to
 Non-tracking mode discharge.
 -P.30
 Remove jumper PG1.
 Change PR132 from 1.82K to 2.4K to adjust OCP.
 -P.31
 Remove jumper PG2, PG7.
 Change PR64 to 150K. Add PC46 0.01uF for power sequence.
 -P.32
 Change PR19 from 0.1 to 0.05 to adjust charge current to 1.5A
 Add PC11 10uF to improve ripple/noise of the charger.
 -P21
 Change PR42 from 13K to 30K to adjust ACIN level.
 -P.33
 Add PU13 and PC147 0.1uF for UL circuit issue.
 Add PC149 1000PF to reduce the pulse on AD_OVP.
 Change PC146 from 0.1uF to 0.01uF to reduce the pulse on AD_OVP.
 Add PQ42, PQ43, PR211 for UL circuit issue.
 Change PU9 P/N from BD4140HFV to BD4141HFV due to supplier change its
 P/N.

0114(1C):
 -P.7
 Change CAMERA LDO to APL5151
 -P.10
 Change power of VCC_SYNC to VCC5CRT
 Tie VGA CN#10 to GND
 -P.14
 ADD PU/PD for GPIO (default input)
 -P.16
 NC Wi-LAN WAKE# PIN#
 Change WLAN_BT_LED circuit
 -P.17
 STUFF 1000p_4 for MS:CD#, SD: CD#, MP
 Change MS/SD Power S/W to MAX1558H
 -P.19
 Connect Codec GPIO1 to EC for AMP standby
 Change +5VA LDO to APL5151 for better PSRR

0119(1D)
 -P.2
 Reserve damping resistor for crystal
 -P.10
 Remove CRT PnP
 -P.18
 Remove CRTSENSE# to disable CRT PnP
 Change AMPMUT# to PIN#24(OD type)
 -P.21
 Change BT PWR S/W to LDO
 -P.32
 Separate adapter OVP from UL circuit

0202(1E)
 -P.7
 Change CAMERA LDO to G909-330T1U(current limit>150mA)
 Change LVDS PWR S/W to G5243A
 -P.14
 PU #1CH_RI#* to RVCC3
 -P.17
 Change R5C833 INTERRUPT to INTB#
 -P.21
 Move CR LED to MB from TP/B

0406A(2C)
 -P.7
 Change U17 to MAX4789
 -P.9
 Reserve L4,L5,L6
 -P.15
 Reserve L2
 -P.19
 Change R51 to connect AGND
 -P.20
 Change AMP(U37) to TPA2017D2
 -P35
 Update Power up sequence

0409 (2E)
 -P.19
 Connect R73 and Q3.1 to 3VPCU rather than RVCC5 for power down pop noise.
 Change R220, R221,R224, R225 to 1.5K from 470ohm for POP-noise
 0409 (2F)
 -P.28
 Add PR192, PR114, PC76 for PU11 thermal protection.
 Change PR191 to 130K for considering 7.5V battery.

0408 (2D)
 -P.27
 Add PC149, PC150 to improve acoustic noise.
 -P.33
 Change PR47 to 249K for considering 7.5V battery.
 Change PR51 to 71.5K to adjust OVP trigger point.
 Change PR52 to 174K to adjust OVP trigger point.

- 1.Level 1 Environment-related Substances Should NEVER be Used.
- 2.Purchase ink, paint, wire rods, and Molding resins only from the business Partners that Sony approves as Green Partners.

				QUANTA COMPUTER	
Title Change History					
Size Custom	Document Number SY2 MB				Rev 2C
Date: Friday, April 10, 2009			Sheet 36 of 36		