

SAMSUNG ELECTRONICS CO.'S PROPERTY.
DO NOT DISCLOSE TO OR DUPLICATE FOR OTHERS
EXCEPT AS AUTHORIZED BY SAMSUNG.

McLaren-15

CPU : IVY Bridge PGA
 Chip Set : Intel Panther Point
 GFX : N13P-GT
 Remarks : Chief River Platform

Model Name : McLaren-15
 PBA Name : MAIN_Quad
 PCB Code : BA41-01898A (PTC)
 BA41-01899A (GCE)
 BA41-01900A (NY)
 Dev. Step : PV
 Revision : 0.9
 T.R. Date : 2011.11.25

Design	CHECK	APPROVAL
<i>SH YOU</i>	<i>SS BAIK</i>	<i>BL LEE</i>

■ Owner : SEC N/P Lab Signature : *SH YOU*

- | | |
|------------------------------|---|
| sheet01 : Cover | sheet33 : LVDS/CAMERA |
| sheet02 : BLOCK DIAGRAM | sheet34 : 80 Port |
| sheet03 : BOARD INFORMATION | sheet35 : CRT |
| sheet04 : POWER DIAGRAM | sheet36 : HDMI |
| sheet05 : CLOCK DISTRIBUTION | sheet37 : Audio - ALC269 |
| sheet06 : Green Clock | sheet38 : Audio - HP/MIC/Woofers Amp |
| sheet07 : Thermal Sensor | sheet39 : Audio - Stereo Amp |
| sheet08 : CPU-IvyBridge | sheet40 : LAN (Realtek RTL8111E) |
| sheet09 : CPU-IvyBridge | sheet41 : 4-in-1 card (AU6437) |
| sheet10 : CPU-IvyBridge | sheet42 : WLAN |
| sheet11 : CPU-IvyBridge | sheet43 : SATA interface |
| sheet12 : DDR3 SODIMM #0 | sheet44 : iSSD |
| sheet13 : DDR3 SODIMM #1 | sheet45 : MICOM / BIOS |
| sheet14 : PCH-PantherPoint | sheet46 : MICOM Glue Logic (KBD / TP) |
| sheet15 : PCH-PantherPoint | sheet47 : LED for 15" |
| sheet16 : PCH-PantherPoint | sheet48 : 2 USB 2.0 |
| sheet17 : PCH-PantherPoint | sheet49 : USB 3.0 connector |
| sheet18 : PCH-PantherPoint | sheet50 : Power - charger |
| sheet19 : N13P-GT | sheet51 : Power - P3.3V_AUX / P5.0V_ALW |
| sheet20 : N13P-GT | sheet52 : Power - P1.05V (Chipset Power) |
| sheet21 : N13P-GT | sheet53 : Power - VCCSA (Chipset Power) |
| sheet22 : N13P-GT | sheet54 : Power - DDR3 |
| sheet23 : N13P-GT | sheet55 : Power - CPU VRM |
| sheet24 : STRAP | sheet56 : Power - EGFX_CORE |
| sheet25 : GFX memory | sheet57 : Power - Switched Power 1 |
| sheet26 : GFX memory | sheet58 : Power - Switched Power 2 |
| sheet27 : GFX memory | sheet59 : Power - Switched Power for iSSD |
| sheet28 : GFX memory | sheet60 : Power - Power Discharge |
| | sheet61 : Mount Hole / Thermal Hole |
| | sheet62 : USB Sub B'D (15") |
| | sheet63 : USB Sub B'D (17") |

DRAW	SH, YOU	DATE	3/11/2011	TITLE	McLaren-15_QUAD MAIN COVER	SAMSUNG ELECTRONICS PART NO. BA41-01898A
CHECK	SS, BAIK	DEV. STEP	PV			
APPROVAL	BL, LEE	REV	REV 0.9			
MODULE CODE		LAST EDIT	October, 24, 2011 9:57:03 PM	PAGE	1	OF 63

SAMSUNG PROPRIETARY
 THIS DOCUMENT CONTAINS CONFIDENTIAL
 PROPRIETARY INFORMATION THAT IS
 SAMSUNG ELECTRONICS CO.'S PROPERTY.
 DO NOT DISCLOSE TO OR DUPLICATE FOR OTHERS
 EXCEPT AS AUTHORIZED BY SAMSUNG.

BLOCK DIAGRAM

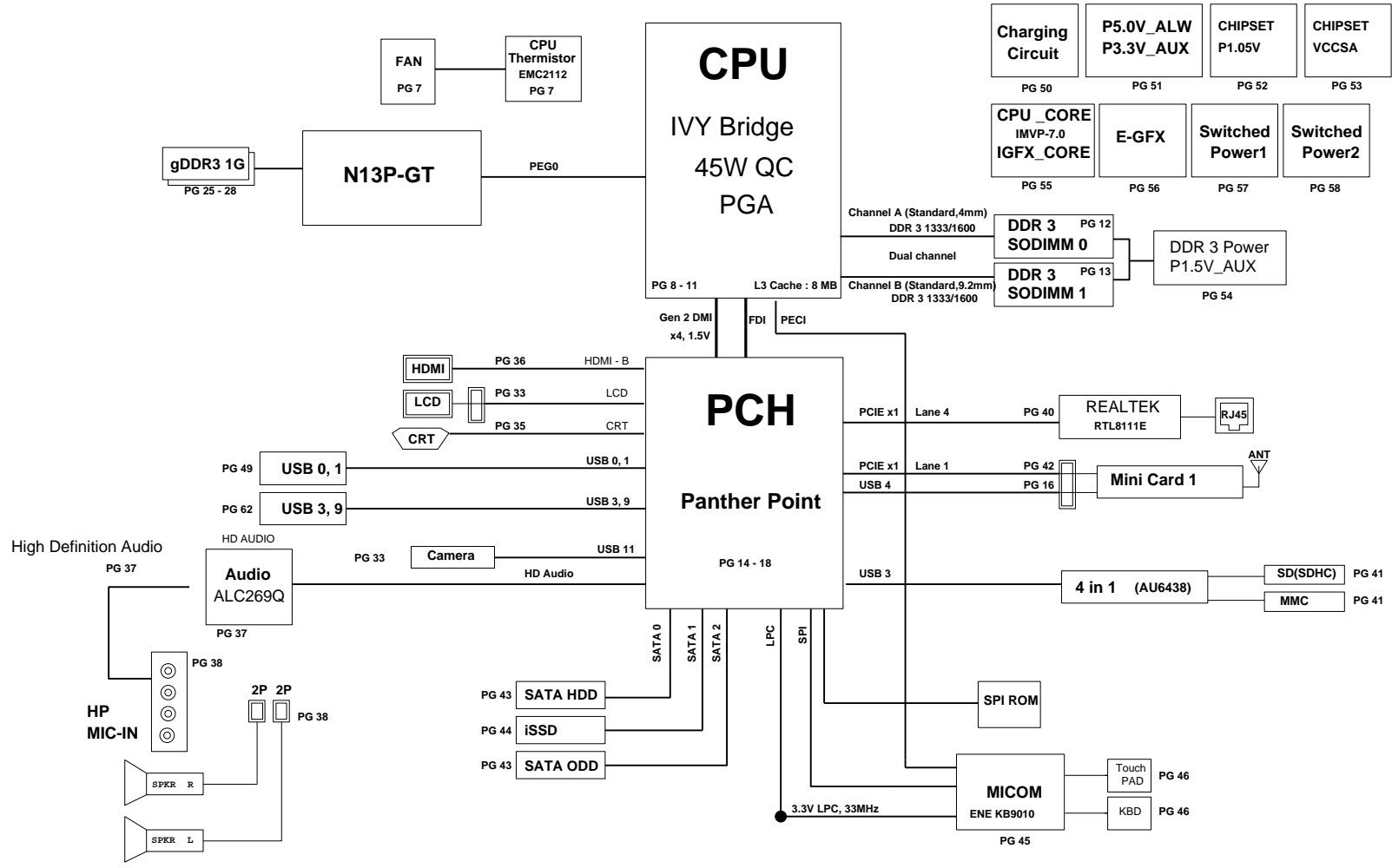

DRAW	MS YANG	DATE	3/11/2011	TITLE	McLaren-15_QUAD MAIN BLOCK DIAGRAM	SAMSUNG ELECTRONICS PART NO. BA41-01662A
CHECK	MK KIM	DEV. STEP	PR			
APPROVAL	BL LEE	REV	REV 1.0			
MODULE CODE	undefined	LAST EDIT	May 20, 2011 21:14:43 PM			
					PAGE	2 OF 51

SAMSUNG PROPRIETARY

THIS DOCUMENT CONTAINS CONFIDENTIAL PROPRIETARY INFORMATION THAT IS SAMSUNG ELECTRONICS CO.'S PROPERTY. DO NOT DISCLOSE TO OR DUPLICATE FOR OTHERS EXCEPT AS AUTHORIZED BY SAMSUNG.

BOARD INFORMATION

SCHEMATIC ANNOTATIONS AND BOARD INFORMATION

Voltage Rails		Active in
VDC	Primary DC system power supply (7 to 21V)	S4 - S5
P3.3V_MICOM	3.3V always power rail (for Micom)	
P5.0V_STB	5.0V always power rail	
P5.0V_ALW	5.0V always power rail	
P3.3V_ALW	3.3V always power rail	
P12.0V_ALW	12.0V always power rail	S3
P5.0V_AUX	5.0V switched on power rail (off in S4-S5)	
P3.3V_AUX	3.3V switched on power rail (off in S4-S5)	
P1.5V_AUX	1.5V power rail for DDR3 (off in S4-S5)	
P5.0V	5.0V switched power rail (off in S3-S5)	S0
P3.3V	3.3V switched power rail (off in S3-S5)	
P1.8V	1.8V switched power rail (off in S3-S5)	
P1.5V	1.5V switched power rail (off in S3-S5)	
P0.75V	0.75V power rail for DDR3 (off in S3-S5)	
P0.8V	0.8V switched power rail (off in S3-S5)	
VCC_CORE	Core Voltage for CPU	S0
EGFX_CORE	Core Voltage for GPU	
P1.05V (VCCP)	VCC for COUGARPOINT	
P3.3V_D	3.3V discrete power rail for N12X	
P1.5V_D	1.5V discrete power rail for N12X	
P1.05V_D	1.05V discrete power rail for N12X	

Crystal / Oscillator			
TYPE	FREQUENCY	DEVICE	USAGE
Crystal	25MHz	ISSD	Express Cache
Crystal	25MHz	GREENCLK	GREENCLK
Crystal	27MHz	N13P-GT	NVIDIA
GREENCLK	32.768KHz	PCH	PCH
GREENCLK	32.768KHz	MICOM	MICOM
GREENCLK	25MHz	PCH	PCH
GREENCLK	25MHz	LAN	LAN

LCD Panel Detect (TBD)		
Devices	Resolution	PANNEL_DETECT_0

USB PORT Assign		PCI Express Assign	
PORT #	ASSIGNED TO	PORT #	ASSIGNED TO
0	SYSTEM PORT 0	1	Mini Card 1 (WLAN)
1	SYSTEM PORT 1	2	NC
2	Multi Memory Card Controller	3	NC
3	SYSTEM PORT 2	4	LAN CONTROLLER
4	Mini PCI Express	5	NC
5	NC	6	NC
6	NC	7	NC
7	NC	8	NC
8	NC		
9	SYSTEM PORT 3		
10	NC		
11	Camera(LCD Cable)		
12	NC		
13	NC		

I ² C / SMB Address			
Devices	Address	Hex	Bus
HM65	Master	-	SMBUS Master
CPU Thermal Sensor	0111 101x	7Ah	Thermal Sensor
SODIMM0	1010 000x	A0h	-
SODIMM1	1010 010x	A4h	-
Thermal Sensor on SODIMM0	0011 000x	30h	-
Thermal Sensor on SODIMM1	0011 010x	34h	-
Thermal Sensor on board	1101 100x	98h	-
Power thermal management TS	1101 011x	96h	-

SATA PORT Assign	
PORT #	ASSIGNED TO
0	HDD
1	SSD
2	ODD
3	HDD
4	NC
5	NC

DRAW	MS YANG	DATE	3/11/2011	TITLE	PETRONAS-15_QUAD MAIN BOARD INFO	SAMSUNG ELECTRONICS PART NO. BA41-01662A
CHECK	MK KIM	DEV. STEP	PR			
APPROVAL	BL LEE	REV	REV 1.0			
MODULE CODE	undefined	LAST EDIT	May 20, 2011 21:14:43 PM			
				PAGE	3	OF 51

SAMSUNG PROPRIETARY

THIS DOCUMENT CONTAINS CONFIDENTIAL PROPRIETARY INFORMATION THAT IS SAMSUNG ELECTRONICS CO.'S PROPERTY. DO NOT DISCLOSE TO OR DUPLICATE FOR OTHERS EXCEPT AS AUTHORIZED BY SAMSUNG.

POWER DIAGRAM

Rev 1.0

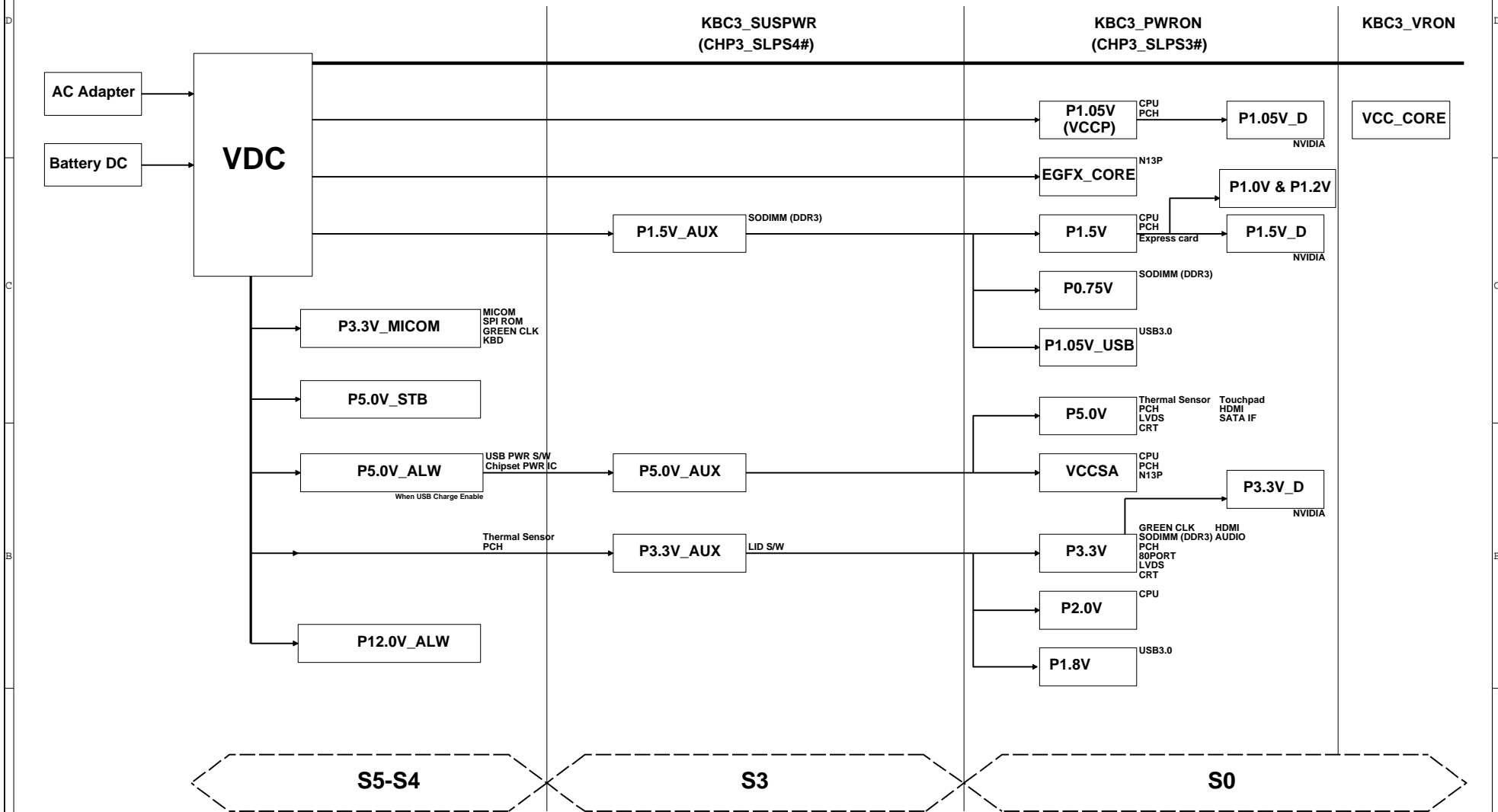

DRAW	MS YANG	DATE	3/11/2011	TITLE	PETRONAS-15_QUAD MAIN POWER DIAGRAM	SAMSUNG ELECTRONICS PART NO. BA41-01662A
CHECK	MK KIM	DEV. STEP	PR			
APPROVAL	BL LEE	REV	REV 1.0			
MODULE CODE	undefined	LAST EDIT	May 20, 2011 21:14:43 PM	PAGE 4 OF 51		

SAMSUNG PROPRIETARY
 THIS DOCUMENT CONTAINS CONFIDENTIAL
 PROPRIETARY INFORMATION THAT IS
 SAMSUNG ELECTRONICS CO.'S PROPERTY.
 DO NOT DISCLOSE TO OR DUPLICATE FOR OTHERS
 EXCEPT AS AUTHORIZED BY SAMSUNG.

CLOCK DISTRIBUTION Rev. 1.0

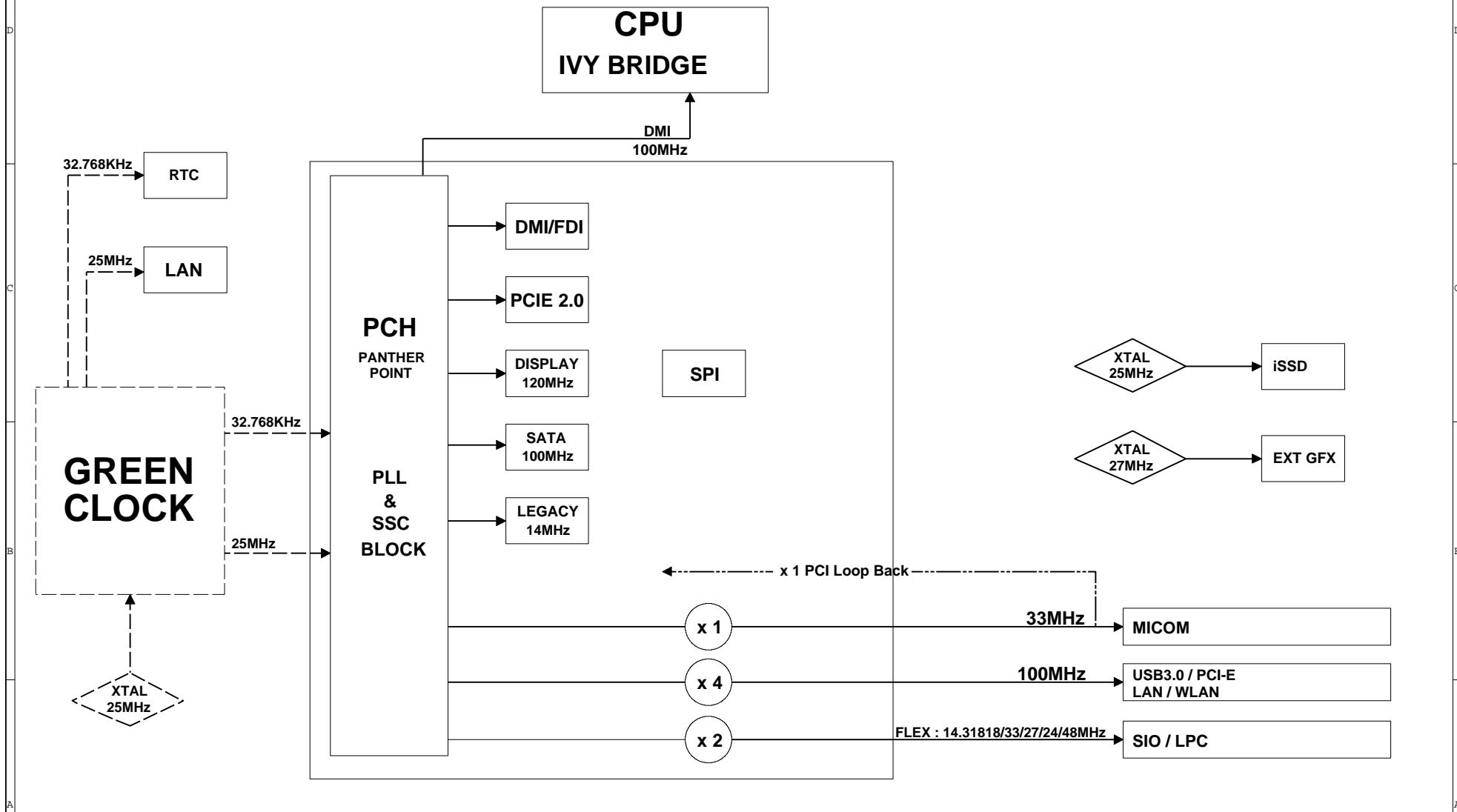

DRAW	MS YANG	DATE	3/11/2011	TITLE	PETRONAS-15_QUAD	SAMSUNG ELECTRONICS
CHECK	MK KIM	DEV. STEP	PR	MAIN		
APPROVAL	BL LEE	REV	REV 1.0	CLOCK DIAGRAM	PART NO.	BA41-01662A
MODULE CODE	undefined	LAST EDIT	May 20, 2011 21:14:43 PM	PAGE	5	OF 51

SAMSUNG PROPRIETARY

THIS DOCUMENT CONTAINS CONFIDENTIAL PROPRIETARY INFORMATION THAT IS SAMSUNG ELECTRONICS CO.'S PROPERTY. DO NOT DISCLOSE TO OR DUPLICATE FOR OTHERS EXCEPT AS AUTHORIZED BY SAMSUNG.

CLOCK DISTRIBUTOR

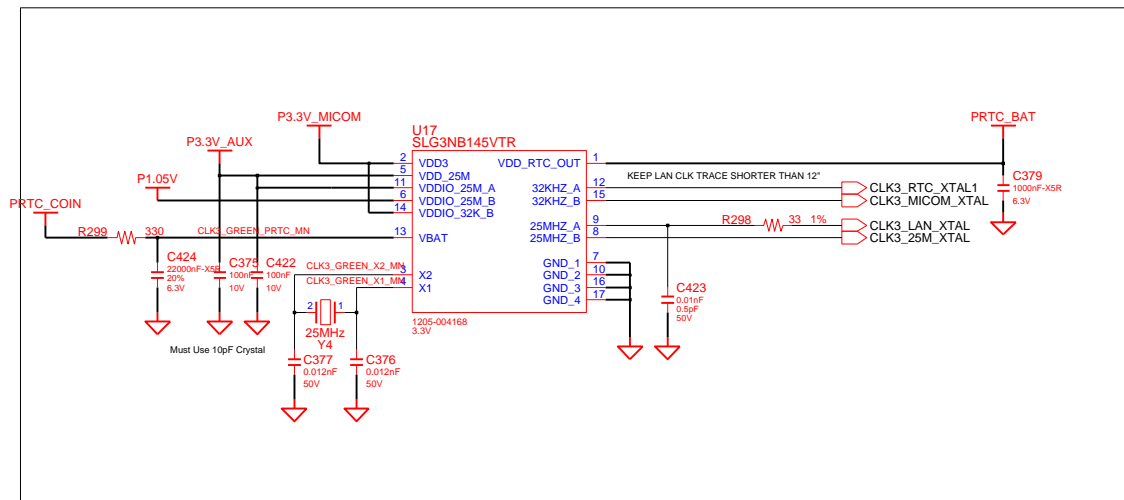

GREENCLK
GREENCLK
GREENCLK
GREENCLK
GREENCLK
GREENCLK
GREENCLK
GREENCLK

DRAW	MS YANG	DATE	3/11/2011	TITLE	PETRONAS-15_QUAD CLOCK CLOCK DISTRIBUTION	SAMSUNG ELECTRONICS	
CHECK	MK KIM	DEV.STEP	PR	PART NO.			BA41-01662A
APPROVAL	BL LEE	REV	REV 1.0				
MODULE CODE	undefined	LAST EDIT	May 20, 2011 21:14:43 PM	PAGE	6	OF 51	

SAMSUNG PROPRIETARY

THIS DOCUMENT CONTAINS CONFIDENTIAL PROPRIETARY INFORMATION THAT IS SAMSUNG ELECTRONICS CO.'S PROPERTY. DO NOT DISCLOSE TO OR DUPLICATE FOR OTHERS EXCEPT AS AUTHORIZED BY SAMSUNG.

THERMAL SENSOR & FAN CONTROL

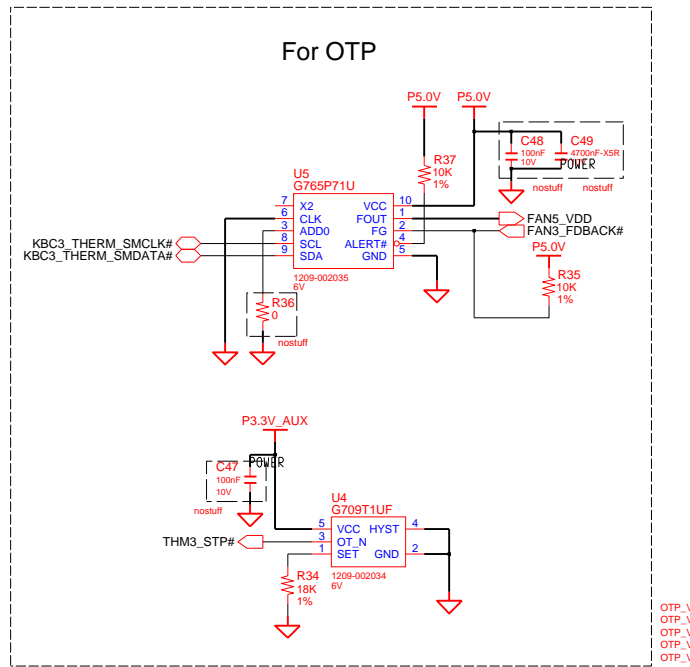
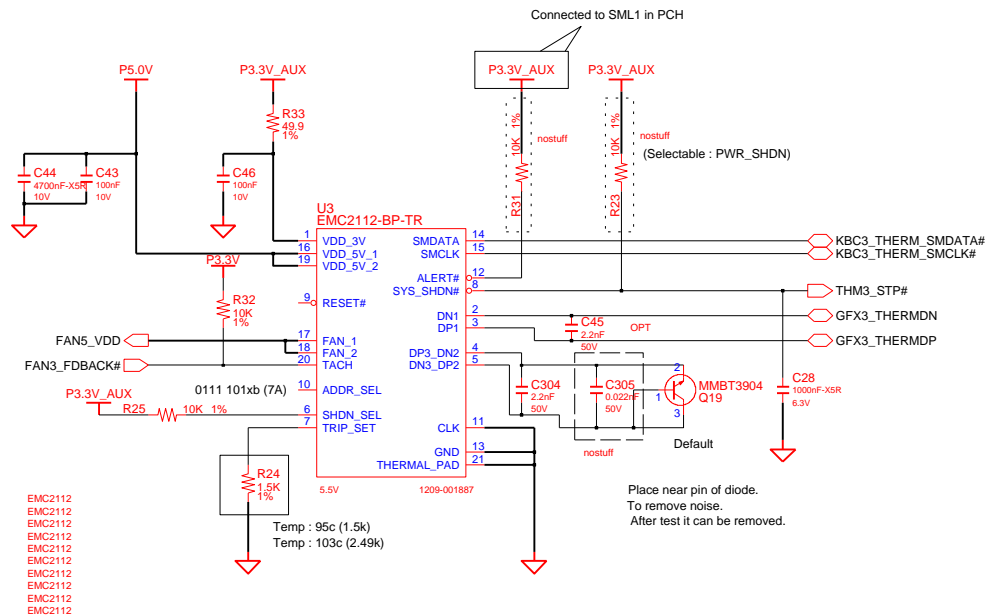

Temperature : 95.78c
 confirmed by thermal charger
 (2011.05.02)
 $R_{th}(kohm) = 0.0012T^2 - 0.9308T + 96.147$

FAN PEM

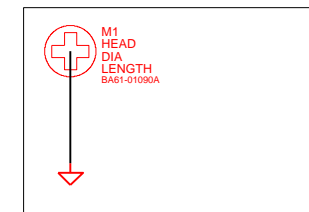

ADDRESSSEL MODE	
0	0101 111xb
✓ HIGH Z	0111 101xb (7A)
1	0101 110xb

SHDNSEL MODE	
0	INTEL TR MODE
HIGH Z	AMD CPU/DIODE MODE
✓ 1	EXT.DIODE 2 MODE

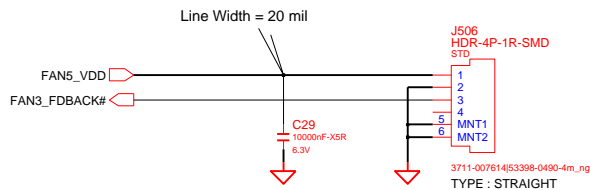

DESIGN	MS YANG	DATE	3/11/2011	TITLE	PETRONAS-15_QUAD	SAMSUNG
CHECK	MK KIM	DEV.STEP	PR		THERMAL SENSOR	ELECTRONICS
APPROVAL	BL LEE	REV	REV 1.0		THERMAL SENSOR EMC2112	PART NO. BA41-01662A
MODULE CODE		LAST EDIT			May 20, 2011 21:14:43 PM	PAGE 7 OF 51

SAMSUNG PROPRIETARY

THIS DOCUMENT CONTAINS CONFIDENTIAL PROPRIETARY INFORMATION THAT IS SAMSUNG ELECTRONICS CO.'S PROPERTY. DO NOT DISCLOSE TO OR DUPLICATE FOR OTHERS EXCEPT AS AUTHORIZED BY SAMSUNG.

IVYBRIDGE PROCESSOR (DMI,PEG, FDI)

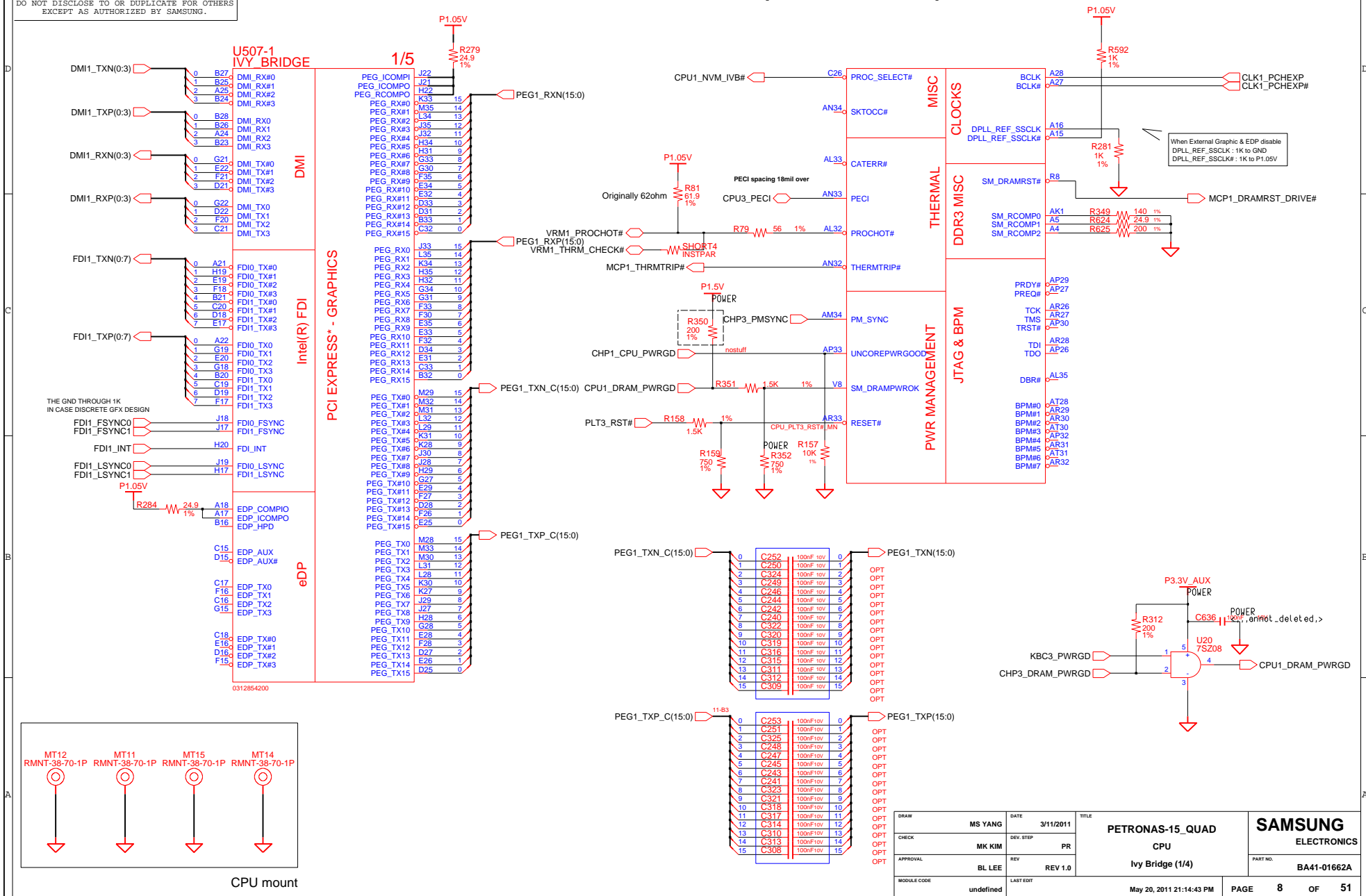

DRAW	MS YANG	DATE	3/11/2011	TITLE	PETRONAS-15_QUAD	SAMSUNG ELECTRONICS
CHECK	MK KIM	DEV. STEP	PR		CPU	
APPROVAL	BL LEE	REV	REV 1.0		Ivy Bridge (1/4)	PART NO. BA41-01662A
MODULE CODE	undefined	LAST EDIT			May 20, 2011 21:14:43 PM	PAGE 8 OF 51

SAMSUNG PROPRIETARY

THIS DOCUMENT CONTAINS CONFIDENTIAL PROPRIETARY INFORMATION THAT IS SAMSUNG ELECTRONICS CO.'S PROPERTY. DO NOT DISCLOSE TO OR DUPLICATE FOR OTHERS EXCEPT AS AUTHORIZED BY SAMSUNG.

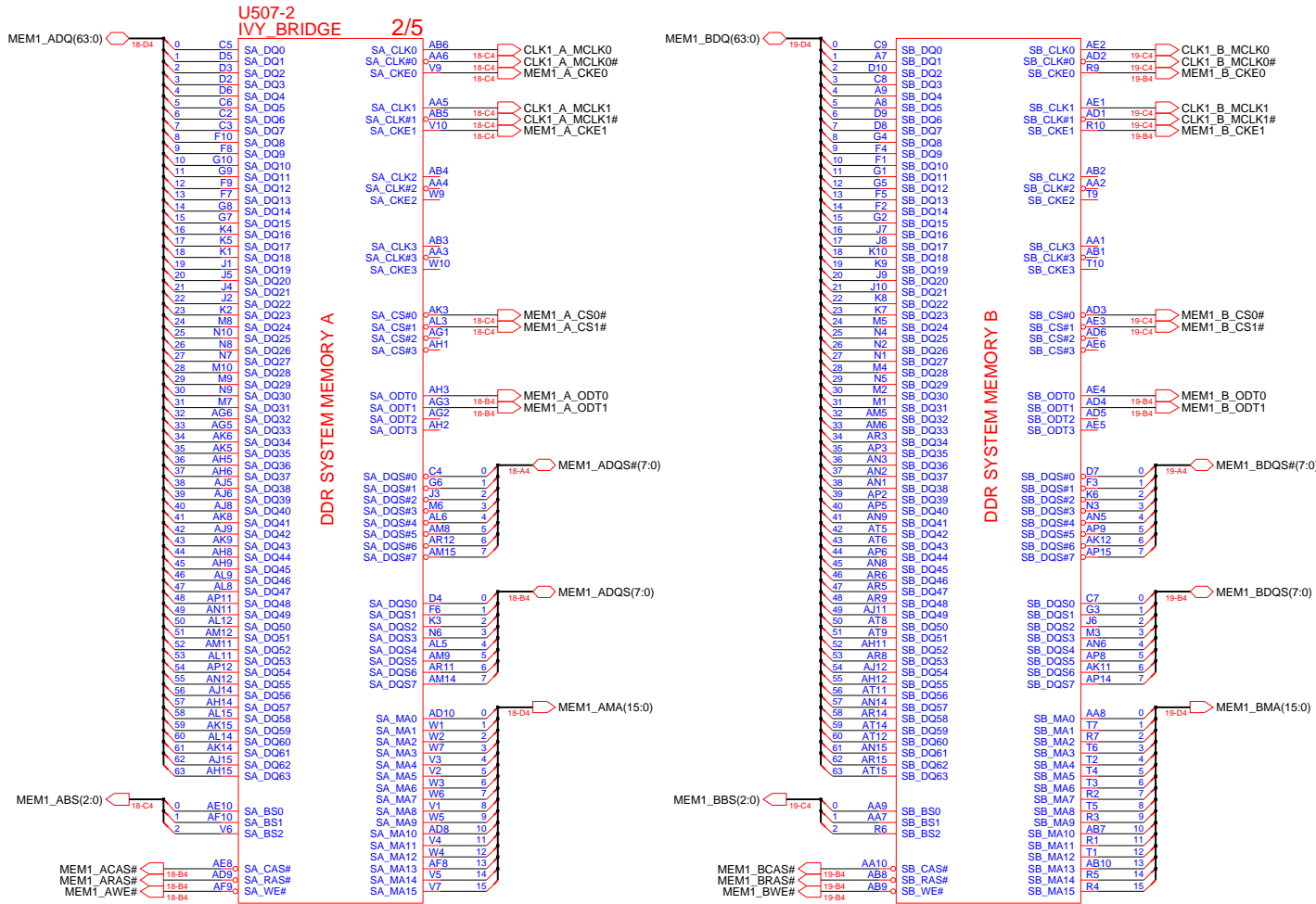

0312854200

DRAW	MS YANG	DATE	3/11/2011	TITLE	PETRONAS-15_QUAD CPU Ivy Bridge (2/4)	SAMSUNG ELECTRONICS
CHECK	MK KIM	DEV. STEP	PR			PART NO. BA41-01662A
APPROVAL	BL LEE	REV	REV 1.0			
MODULE CODE	undefined	LAST EDIT	May 20, 2011 21:14:43 PM	PAGE	9	OF 51

SAMSUNG PROPRIETARY

THIS DOCUMENT CONTAINS CONFIDENTIAL PROPRIETARY INFORMATION THAT IS SAMSUNG ELECTRONICS CO.'S PROPERTY. DO NOT DISCLOSE TO OR DUPLICATE FOR OTHERS EXCEPT AS AUTHORIZED BY SAMSUNG.

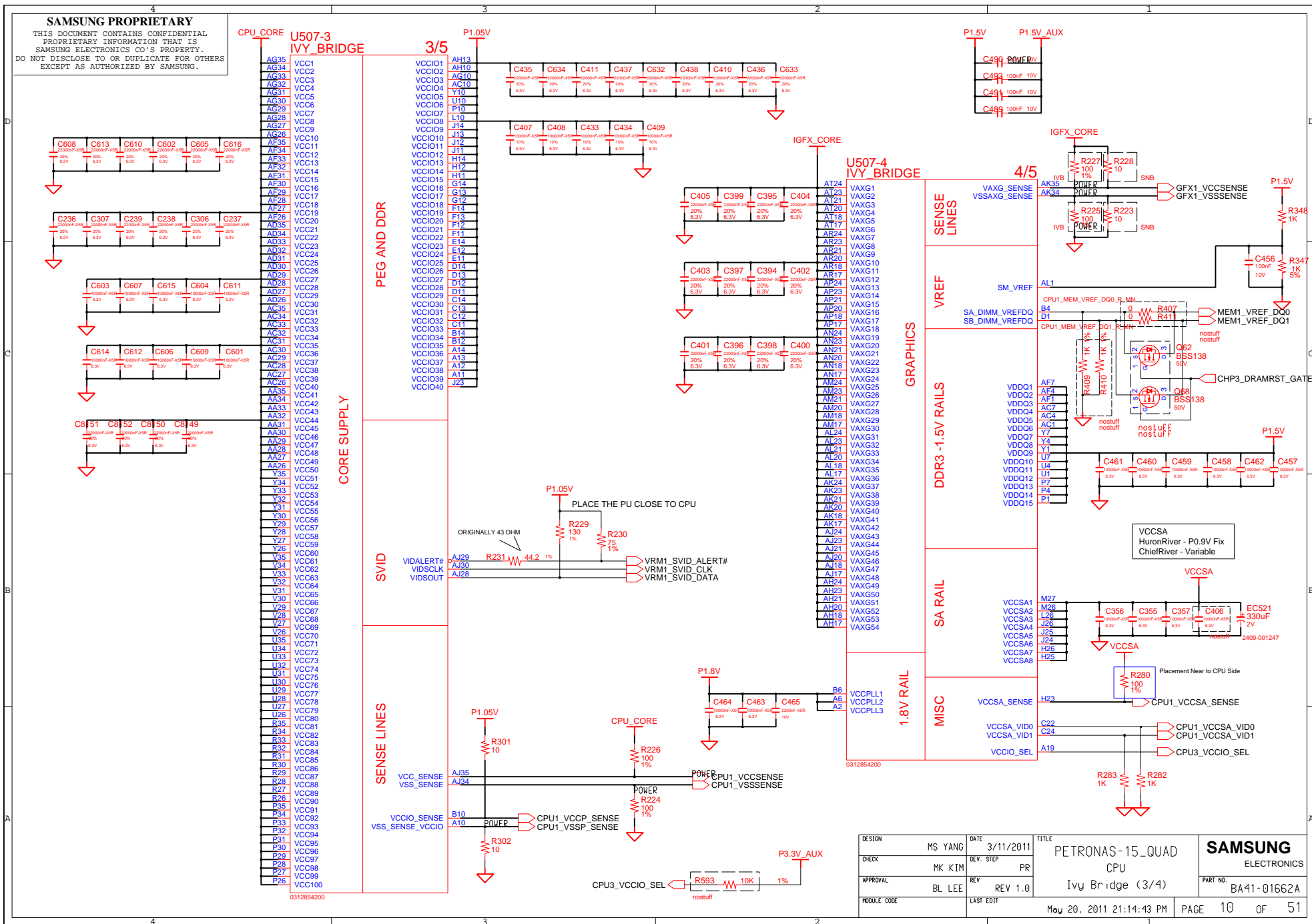

DESIGN	MS YANG	DATE	3/11/2011	TITLE	PETRONAS-15_QUAD	SAMSUNG ELECTRONICS
CHECK	MK KIM	DEV. STEP	PR		CPU	
APPROVAL	BL LEE	REV	REV 1.0		Ivy Bridge (3/4)	PART NO. BA-01-01662A
MODULE CODE		LAST EDIT				

SAMSUNG PROPRIETARY

THIS DOCUMENT CONTAINS CONFIDENTIAL PROPRIETARY INFORMATION THAT IS SAMSUNG ELECTRONICS CO.'S PROPERTY. DO NOT DISCLOSE TO OR DUPLICATE FOR OTHERS EXCEPT AS AUTHORIZED BY SAMSUNG.

**U507-5
IVY BRIDGE 5/5**

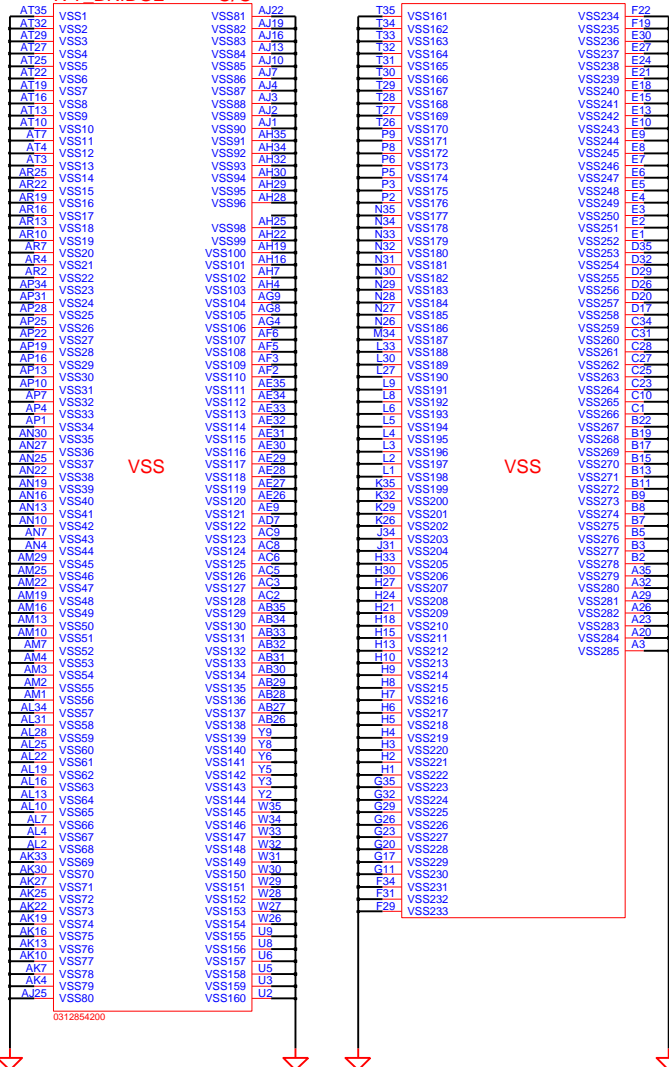

SHOULD BE PLACED!!!

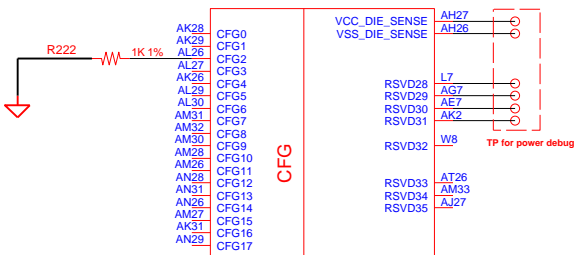

CFG Straps for Processor

PEG STATIC LANE REVERSAL - CFG2 IS FOR THE 16X	
CFG2	1: (DEFAULT) NORMAL OPERATION 0: LANE REVERSED
PCIE PORT BIFURCATION STRAPS	
CFG[6:5]	11: (DEFAULT) X16 - DEVICE 1 FUNCTIONS 1 AND 2 DISABLED 10: X8, X8 - DEVICE 1 FUNCTION 1 ENABLED; FUNCTION 2 DISABLED 01: RESERVED - (DEVICE 1 FUNCTION 1 DISABLED; FUNCTION 2 ENABLED) 00: X8, X4, X4 - DEVICE 1 FUNCTIONS 1 AND 2 ENABLED
Display Port Presence	
CFG4	1: Disabled - No DP device is connected to eDP 0: Enabled - (DP device is connected to eDP)
PEG DEFER TRAINING	
CFG7	1: (DEFAULT) PEG TRAIN IMMEDIATELY FOLLOWING XXRESETB DEASSERTION 0: PEG WAIT FOR BIOS FOR TRAINING

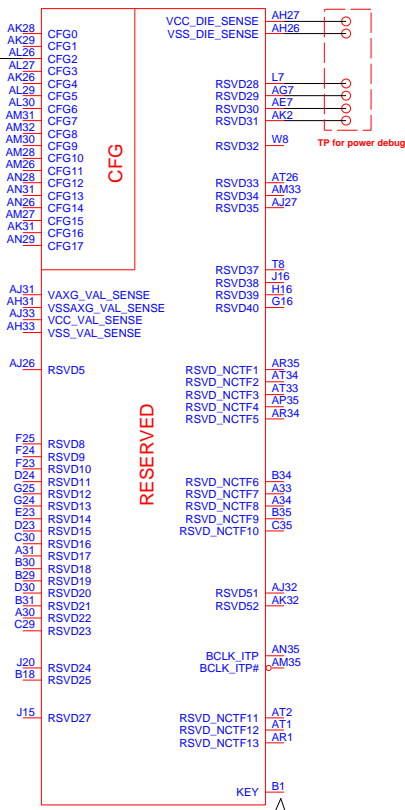

FOR RPGA SOCKET
RSVD59 PIN SHOULD BE LEFT NC

DESIGN	MS YANG	DATE	3/11/2011	TITLE	PETRONAS-15_QUAD CPU	SAMSUNG ELECTRONICS PART NO. BA41-01662A
CHECK	MK KIM	DEV. STEP	PR		Ivy Bridge (4/4)	
APPROVAL	BL LEE	REV	REV 1.0			
MODULE CODE		LAST EDIT		May 20, 2011 21:14:43 PM	PAGE 11 OF 51	

SAMSUNG PROPRIETARY

THIS DOCUMENT CONTAINS CONFIDENTIAL
 PROPRIETARY INFORMATION THAT IS
 SAMSUNG ELECTRONICS CO.'S PROPERTY.
 DO NOT DISCLOSE TO OR DUPLICATE FOR OTHERS
 EXCEPT AS AUTHORIZED BY SAMSUNG.

SO-DIMM#0 : 2nd SO-DIMM

DDR SO-DIMM #0

Height : 9.2 mm (REVERSE)

P/N : 3709-001656 (Foxconn)

P/N : 3709-001609 (Concraft)

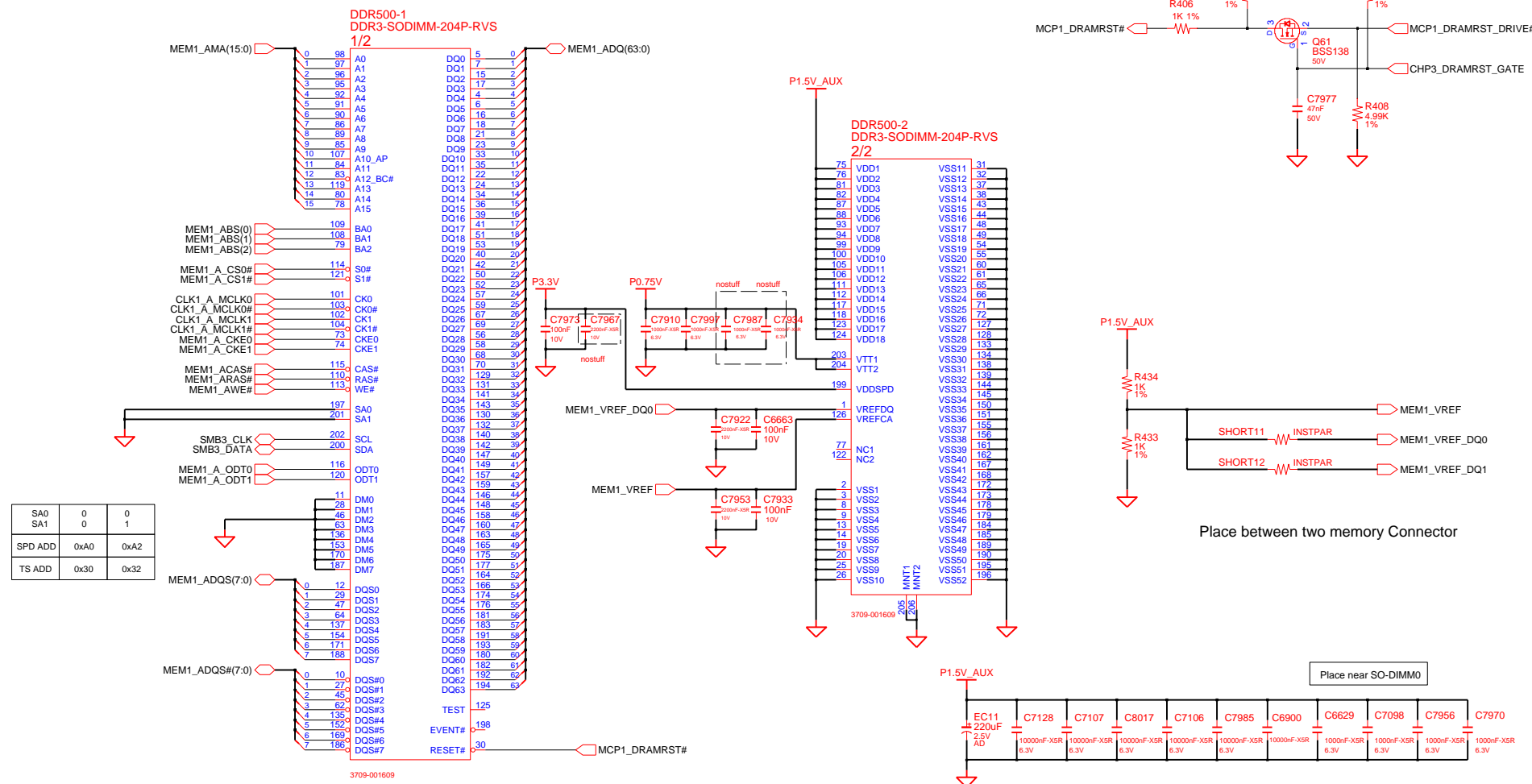

DRAW	MS YANG	DATE	3/11/2011	TITLE	PETRONAS-15_QUAD	SAMSUNG ELECTRONICS
CHECK	MK KIM	DEV. STEP	PR	SODIMM A		
APPROVAL	BL LEE	REV	REV 1.0	DDR3		PART NO. BA41-01662A
MODULE CODE	undefined	LAST EDIT	May 20, 2011 21:14:43 PM	PAGE	12	OF 51

SAMSUNG PROPRIETARY
 THIS DOCUMENT CONTAINS CONFIDENTIAL
 PROPRIETARY INFORMATION THAT IS
 SAMSUNG ELECTRONICS CO'S PROPERTY.
 DO NOT DISCLOSE TO OR DUPLICATE FOR OTHERS
 EXCEPT AS AUTHORIZED BY SAMSUNG.

SO-DIMM#1 : 1st SO-DIMM

DDR SO-DIMM #1

Height : 4.0 mm (REVERSE)

P/N : 3709-001654 (Foxconn)

P/N : 3709-001608 (Concraft)

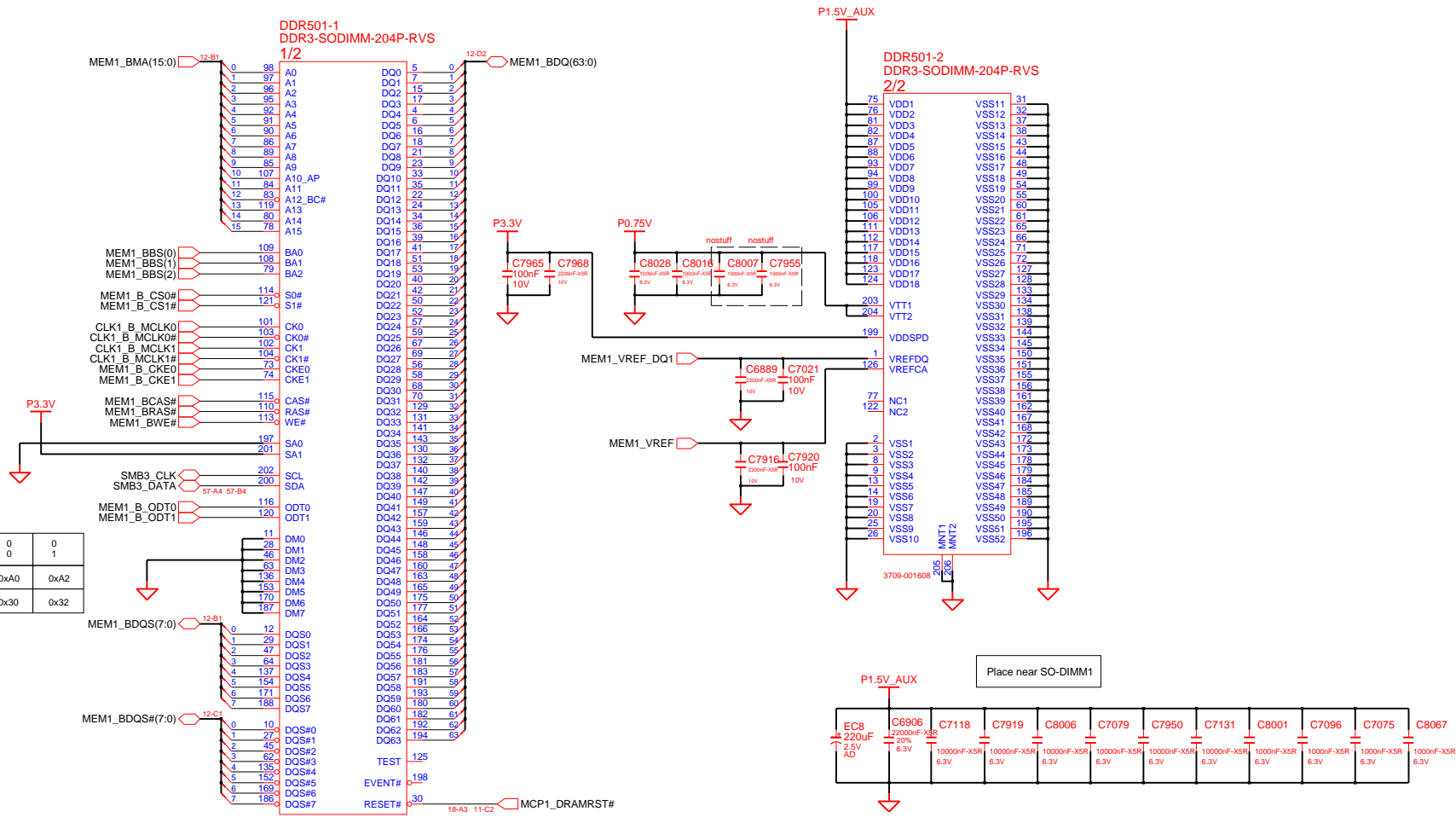

SA0	0	0	1
SA1	0	0	1
SPD ADD	0xA0	0xA2	
TS ADD	0x30	0x32	

DRAW	MS YANG	DATE	3/11/2011	TITLE	PETRONAS-15_QUAD	SAMSUNG ELECTRONICS
CHECK	MK KIM	DEV. STEP	PR	SODIMM B		
APPROVAL	BL LEE	REV	REV 1.0	DDR3		PART NO. BA41-01662A
MODULE CODE		LAST ENT		May 20, 2011 21:14:43 PM	PAGE	13 OF 51

SAMSUNG PROPRIETARY
 THIS DOCUMENT CONTAINS CONFIDENTIAL
 PROPRIETARY INFORMATION THAT IS
 SAMSUNG ELECTRONICS CO'S PROPERTY.
 DO NOT DISCLOSE TO OR DUPLICATE FOR OTHERS
 EXCEPT AS AUTHORIZED BY SAMSUNG.

NO REBOOT STRAP

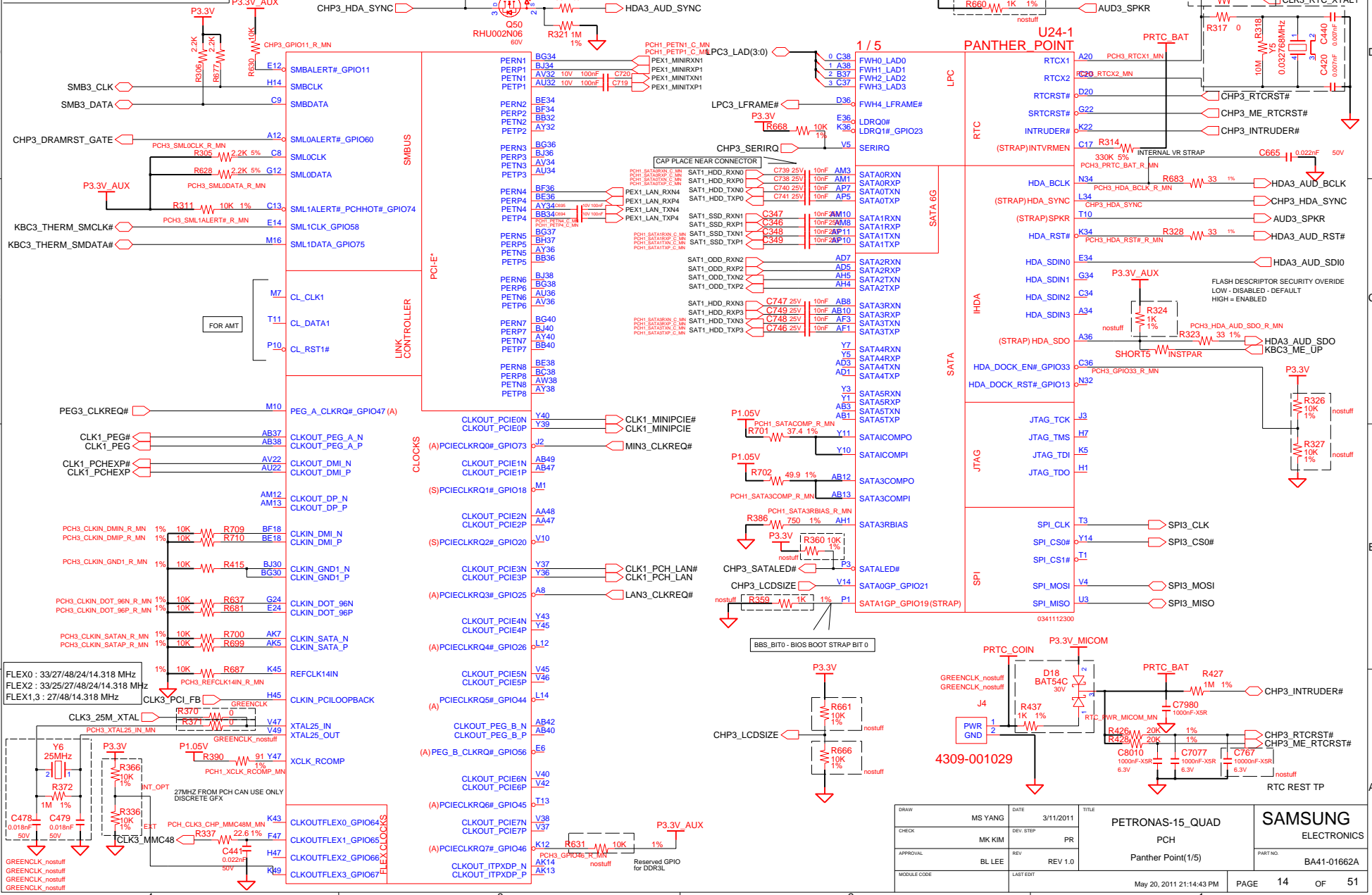

DRAW	MS YANG	DATE	3/11/2011	TITLE	PETRONAS-15_QUAD	SAMSUNG ELECTRONICS
CHECK	MK KIM	DEV_STEP	PR	PCH	Part No.	
APPROVAL	BL LEE	REV	REV 1.0	Panther Point(1/5)		
MODULE CODE		LAST ENT			May 20, 2011 21:14:43 PM	PAGE 14 OF 51

SAMSUNG PROPRIETARY

THIS DOCUMENT CONTAINS CONFIDENTIAL PROPRIETARY INFORMATION THAT IS SAMSUNG ELECTRONICS CO.'S PROPERTY. DO NOT DISCLOSE TO OR DUPLICATE FOR OTHERS EXCEPT AS AUTHORIZED BY SAMSUNG.

U24-2 PANTHER POINT

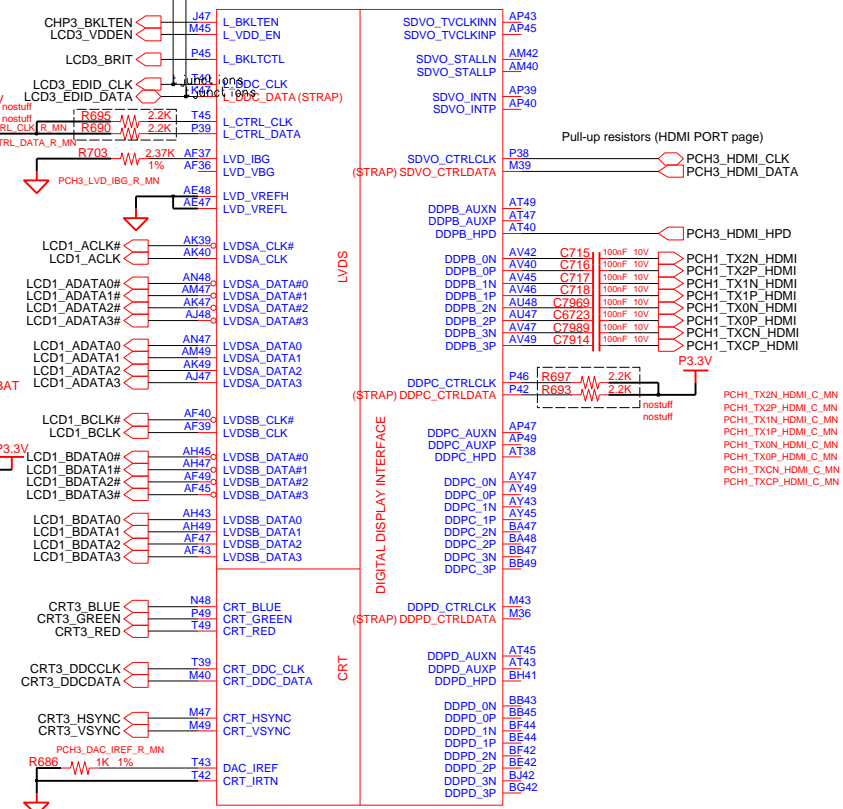
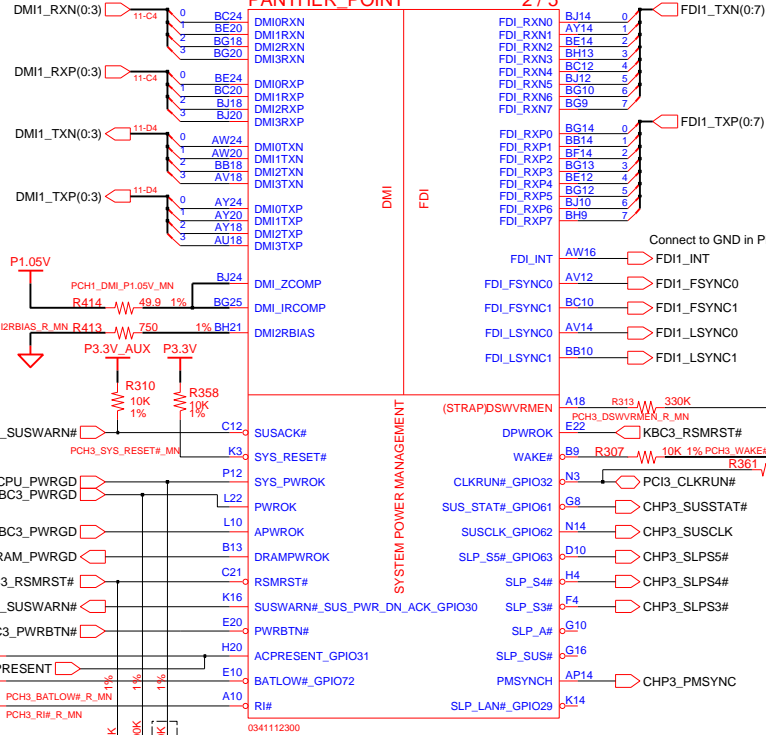

DDI PORT B DETECT	
SDVO_CTRL_DATA	1 PORT B DETECTED
	0 PORT B NOT DETECTED

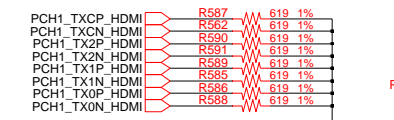
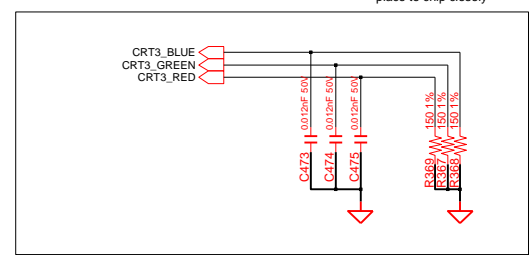
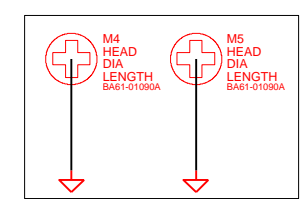

DRAW	MS YANG	DATE	3/11/2011	TITLE	PETRONAS-15_QUAD	SAMSUNG ELECTRONICS
CHECK	MK KIM	DEV. STEP	PR		PCH	
APPROVAL	BL LEE	REV	REV 1.0		Panther Point(2/5)	PART NO. BA41-01662A
MODULE CODE		LAST EDIT			May 20, 2011 21:14:43 PM	PAGE 15 OF 51

SAMSUNG PROPRIETARY

THIS DOCUMENT CONTAINS CONFIDENTIAL PROPRIETARY INFORMATION THAT IS SAMSUNG ELECTRONICS CO'S PROPERTY. DO NOT DISCLOSE TO OR DUPLICATE FOR OTHERS EXCEPT AS AUTHORIZED BY SAMSUNG.

RF OFF Connection Case	
Intel Crane peak Combo BT HW ID : USBVID_8086&PID_0189 Intel Rainbow peak Combo BT HW ID : USBVID_8086&PID_0189	Case 1 Standard Mini-card #51
Broadcom2070 stand alone Module BT HW ID : USBVID_045C&PID_219B New Combo Card Broadcom 4313 1x1 Combo BT HW ID : USBVID_045C&PID_219C	Case 2 Non-Standard Mini-card #5
Broadcom 4325 2x2 Combo BT HW ID : USBVID_045C&PID_219A	

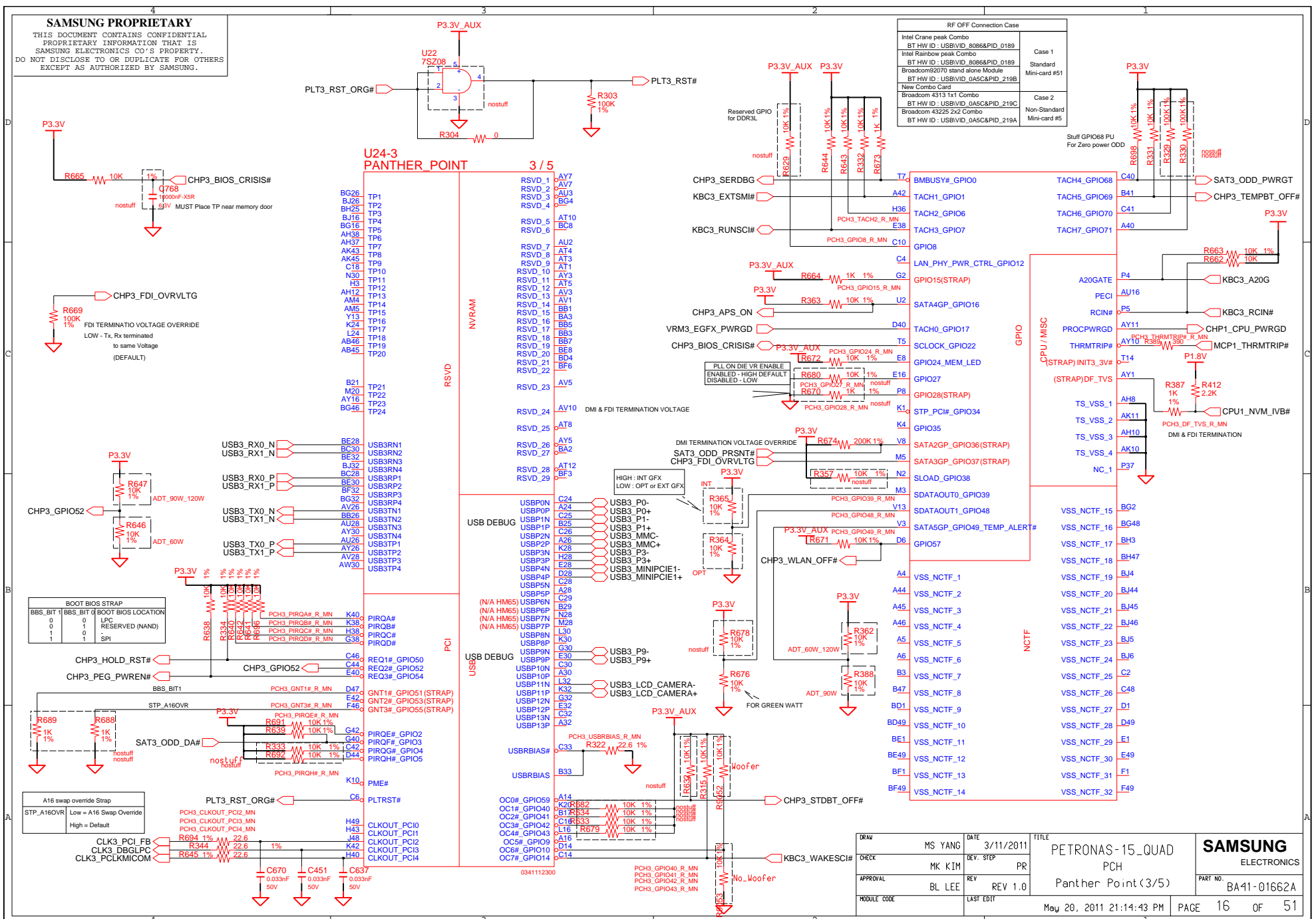

GRAB	MS YANG	DATE	3/11/2011	TITLE	PETRONAS-15_QUAD	SAMSUNG ELECTRONICS	
CHECK	MK KIM	REV. STEP	PR		PCH		
APPROVAL	BL LEE	REV	REV 1.0		Panther Point(3/5)	PART NO. BA41-01662A	
MODULE CODE		LAST EDIT			May 20, 2011 21:14:43 PM		
						PAGE	16
						OF	51

SAMSUNG PROPRIETARY

THIS DOCUMENT CONTAINS CONFIDENTIAL PROPRIETARY INFORMATION THAT IS SAMSUNG ELECTRONICS CO.'S PROPERTY. DO NOT DISCLOSE TO OR DUPLICATE FOR OTHERS EXCEPT AS AUTHORIZED BY SAMSUNG.

U24-4 PANTHER POINT 4 / 5

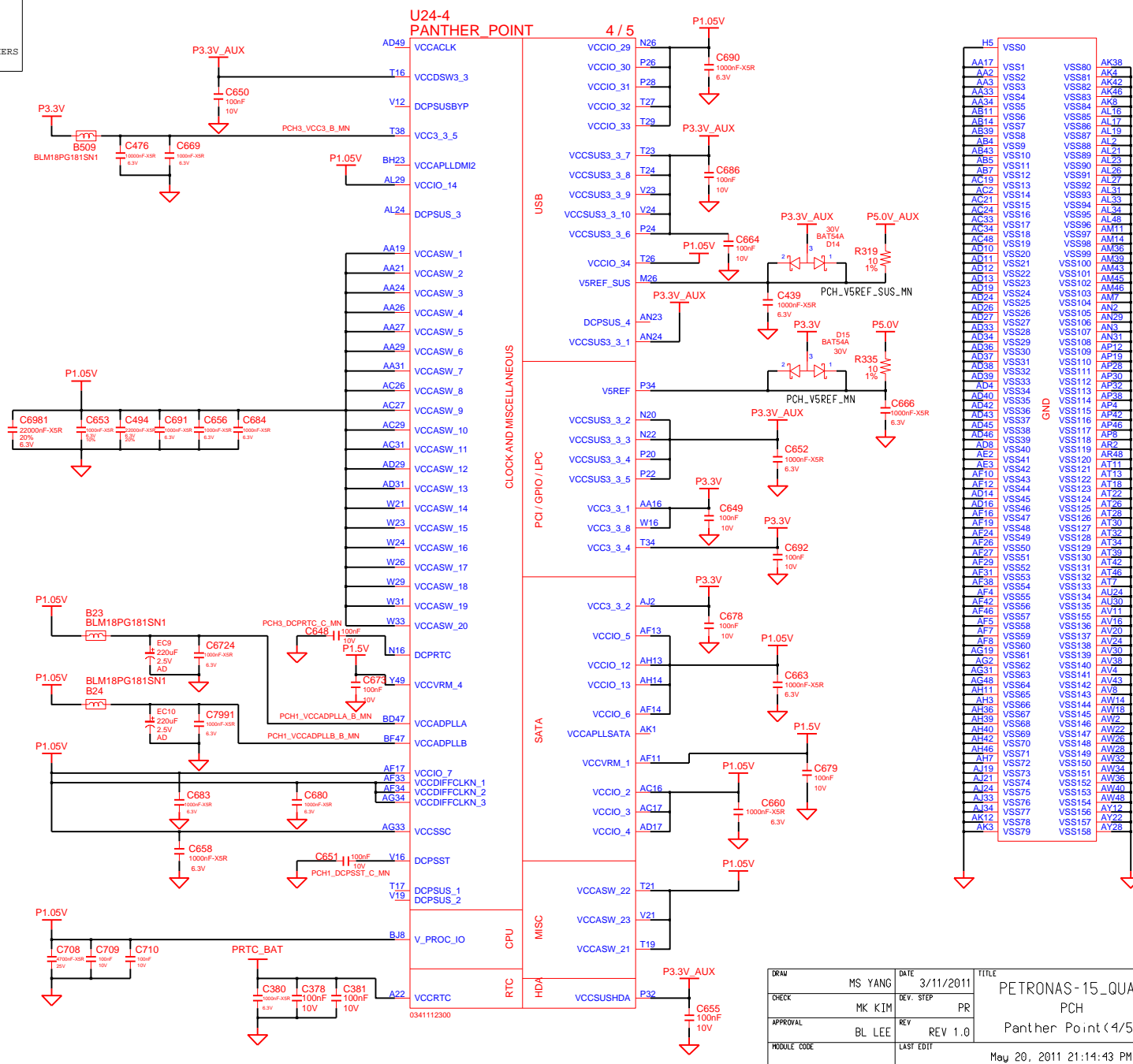

Pin list for H5 and AK series:

H5	VSS0	AK38
AA17	VSS1	AK4
AA2	VSS2	AK42
AA3	VSS3	AK46
AA34	VSS4	VSS83
AA4	VSS5	AK6
AB11	VSS6	AL16
AB14	VSS7	VSS85
AB39	VSS8	VSS86
AB4	VSS9	VSS87
AB43	VSS10	VSS88
AB5	VSS11	VSS89
AB7	VSS12	VSS90
AC19	VSS13	VSS91
AC2	VSS14	VSS92
AC21	VSS15	VSS93
AC24	VSS16	VSS94
AC33	VSS17	VSS95
AC34	VSS18	VSS96
AC48	VSS19	VSS97
AD10	VSS20	VSS98
AD11	VSS21	VSS99
AD12	VSS22	VSS100
AD13	VSS23	VSS101
AD19	VSS24	VSS102
AD24	VSS25	VSS103
AD26	VSS26	VSS104
AD27	VSS27	VSS105
AD3	VSS28	VSS106
AD34	VSS29	VSS107
AD36	VSS30	VSS108
AD37	VSS31	VSS109
AD38	VSS32	VSS110
AD39	VSS33	VSS111
AD4	VSS34	VSS112
AD40	VSS35	VSS113
AD43	VSS36	VSS114
AD45	VSS37	VSS115
AD46	VSS38	VSS116
AD6	VSS39	VSS117
AD8	VSS40	VSS118
AE2	VSS41	VSS119
AE3	VSS42	VSS120
AF10	VSS43	VSS121
AF12	VSS44	VSS122
AF14	VSS45	VSS123
AF16	VSS46	VSS124
AF19	VSS47	VSS125
AF24	VSS48	VSS126
AF26	VSS49	VSS127
AF27	VSS50	VSS128
AF29	VSS51	VSS129
AF31	VSS52	VSS130
AF38	VSS53	VSS131
AF4	VSS54	VSS132
AF42	VSS55	VSS133
AF46	VSS56	VSS134
AF5	VSS57	VSS135
AF7	VSS58	VSS136
AF8	VSS59	VSS137
AG2	VSS60	VSS138
AG31	VSS61	VSS139
AG48	VSS62	VSS140
AH11	VSS63	VSS141
AH3	VSS64	VSS142
AH36	VSS65	VSS143
AH39	VSS66	VSS144
AH40	VSS67	VSS145
AH42	VSS68	VSS146
AH46	VSS69	VSS147
AH7	VSS70	VSS148
AJ19	VSS71	VSS149
AJ21	VSS72	VSS150
AJ24	VSS73	VSS151
AJ33	VSS74	VSS152
AJ34	VSS75	VSS153
AJ4	VSS76	VSS154
AK12	VSS77	VSS155
AK2	VSS78	VSS156
AK3	VSS79	VSS157
		VSS158

DRAW	MS YANG	DATE	3/11/2011	TITLE	PETRONAS-15_QUAD
CHECK	MK KIM	DEV. STEP	PR		PCH
APPROVAL	BL LEE	REV	REV 1.0		Panther Point(4/5)
MODULE CODE		LAST EDIT			

SAMSUNG ELECTRONICS
PART NO. BA41-01662A

May 20, 2011 21:14:43 PM PAGE 17 OF 601

SAMSUNG PROPRIETARY

THIS DOCUMENT CONTAINS CONFIDENTIAL PROPRIETARY INFORMATION THAT IS SAMSUNG ELECTRONICS CO.'S PROPERTY. DO NOT DISCLOSE TO OR DUPLICATE FOR OTHERS EXCEPT AS AUTHORIZED BY SAMSUNG.

U24-5 PANTHER_POINT

This power share with thermal sensor

AY4	VSS159	VSS259	H46
AY42	VSS160	VSS260	K18
AY46	VSS161	VSS261	K30
AY8	VSS162	VSS262	K39
B11	VSS163	VSS263	K46
B15	VSS164	VSS264	K7
B19	VSS165	VSS265	L2
B23	VSS166	VSS266	L20
B27	VSS167	VSS267	L26
B31	VSS168	VSS268	L26
B35	VSS169	VSS269	L28
B39	VSS170	VSS270	L48
B7	VSS171	VSS271	M12
F45	VSS172	VSS272	M18
BB12	VSS173	VSS273	P16
BB16	VSS174	VSS274	M18
BB20	VSS175	VSS275	M24
BB22	VSS176	VSS276	M30
BB24	VSS177	VSS277	M32
BB28	VSS178	VSS278	M34
BB30	VSS179	VSS279	M38
BB38	VSS180	VSS280	M4
BB4	VSS181	VSS281	M42
BB46	VSS182	VSS282	M48
BC14	VSS183	VSS283	N18
BC18	VSS184	VSS284	N18
BC2	VSS185	VSS285	P30
BC22	VSS186	VSS286	P47
BC26	VSS187	VSS287	N47
BC32	VSS188	VSS288	P18
BC34	VSS189	VSS289	T33
BC36	VSS190	VSS290	P40
BC40	VSS191	VSS291	P47
BC42	VSS192	VSS292	P47
BC48	VSS193	VSS293	F7
BD46	VSS194	VSS294	R2
BD5	VSS195	VSS295	R48
BE22	VSS196	VSS296	T12
BE26	VSS197	VSS297	T31
BE40	VSS198	VSS298	T37
BF10	VSS199	VSS299	T4
BF12	VSS200	VSS300	W34
BF16	VSS201	VSS301	T46
BF20	VSS202	VSS302	T47
BF22	VSS203	VSS303	T8
BF24	VSS204	VSS304	T8
BF26	VSS205	VSS305	V11
BF28	VSS206	VSS306	V17
BD3	VSS207	VSS307	V26
BF30	VSS208	VSS308	V27
BF38	VSS209	VSS309	V29
BF40	VSS210	VSS310	V31
BF8	VSS211	VSS311	V36
BG17	VSS212	VSS312	V38
BG21	VSS213	VSS313	V43
BG33	VSS214	VSS314	V7
BG44	VSS215	VSS315	W17
B38	VSS216	VSS316	W2
BH11	VSS217	VSS317	W27
BH15	VSS218	VSS318	W48
BH17	VSS219	VSS319	W48
BH19	VSS220	VSS320	Y12
H10	VSS221	VSS321	Y38
BH27	VSS222	VSS322	Y42
BH31	VSS223	VSS323	Y46
BH33	VSS224	VSS324	Y8
BH35	VSS225	VSS325	BG29
BH39	VSS226	VSS326	N24
BH43	VSS227	VSS327	N24
BH7	VSS228	VSS328	AJ3
D3	VSS229	VSS329	AD47
D12	VSS230	VSS330	B43
D16	VSS231	VSS331	BE10
D18	VSS232	VSS332	BG41
D22	VSS233	VSS333	G14
D24	VSS234	VSS334	H18
D26	VSS235	VSS335	T36
D30	VSS236	VSS336	BG22
D32	VSS237	VSS337	BG24
D34	VSS238	VSS338	C22
D38	VSS239	VSS339	AP13
D42	VSS240	VSS340	M14
D8	VSS241	VSS341	AP3
E18	VSS242	VSS342	AP1
E26	VSS243	VSS343	BE18
E18	VSS244	VSS344	BE18
G20	VSS245	VSS345	BG28
G26	VSS246	VSS346	BJ28
G28	VSS247	VSS347	
G36	VSS248	VSS348	
G48	VSS249	VSS349	
H12	VSS250	VSS350	
H18	VSS251	VSS351	
H22	VSS252	VSS352	
H24	VSS253		
H26	VSS254		
H30	VSS255		
H32	VSS256		
H34	VSS257		
F3	VSS258		

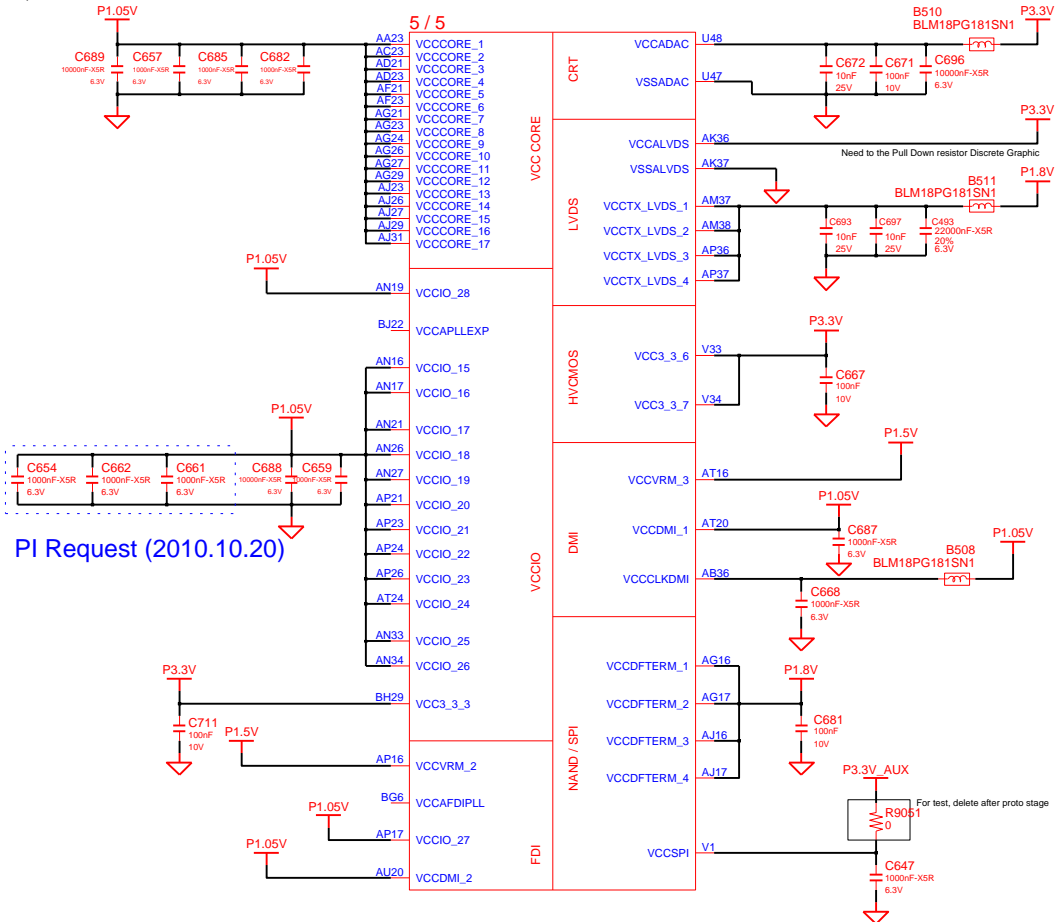

DRAW	MS YANG	DATE	3/11/2011	TITLE	PETRONAS-15_QUAD	SAMSUNG ELECTRONICS
CHECK	MK KIM	DEV. STEP	PR		PCH	
APPROVAL	BL LEE	REV	REV 1.0		Panther Point(5/5)	PART NO. BA41-01662A
MODULE CODE	undefined	LAST EDIT	May 20, 2011 21:14:43 PM	PAGE	18	OF 51

SAMSUNG PROPRIETARY

THIS DOCUMENT CONTAINS CONFIDENTIAL PROPRIETARY INFORMATION THAT IS SAMSUNG ELECTRONICS CO.'S PROPERTY. DO NOT DISCLOSE TO OR DUPLICATE FOR OTHERS EXCEPT AS AUTHORIZED BY SAMSUNG.

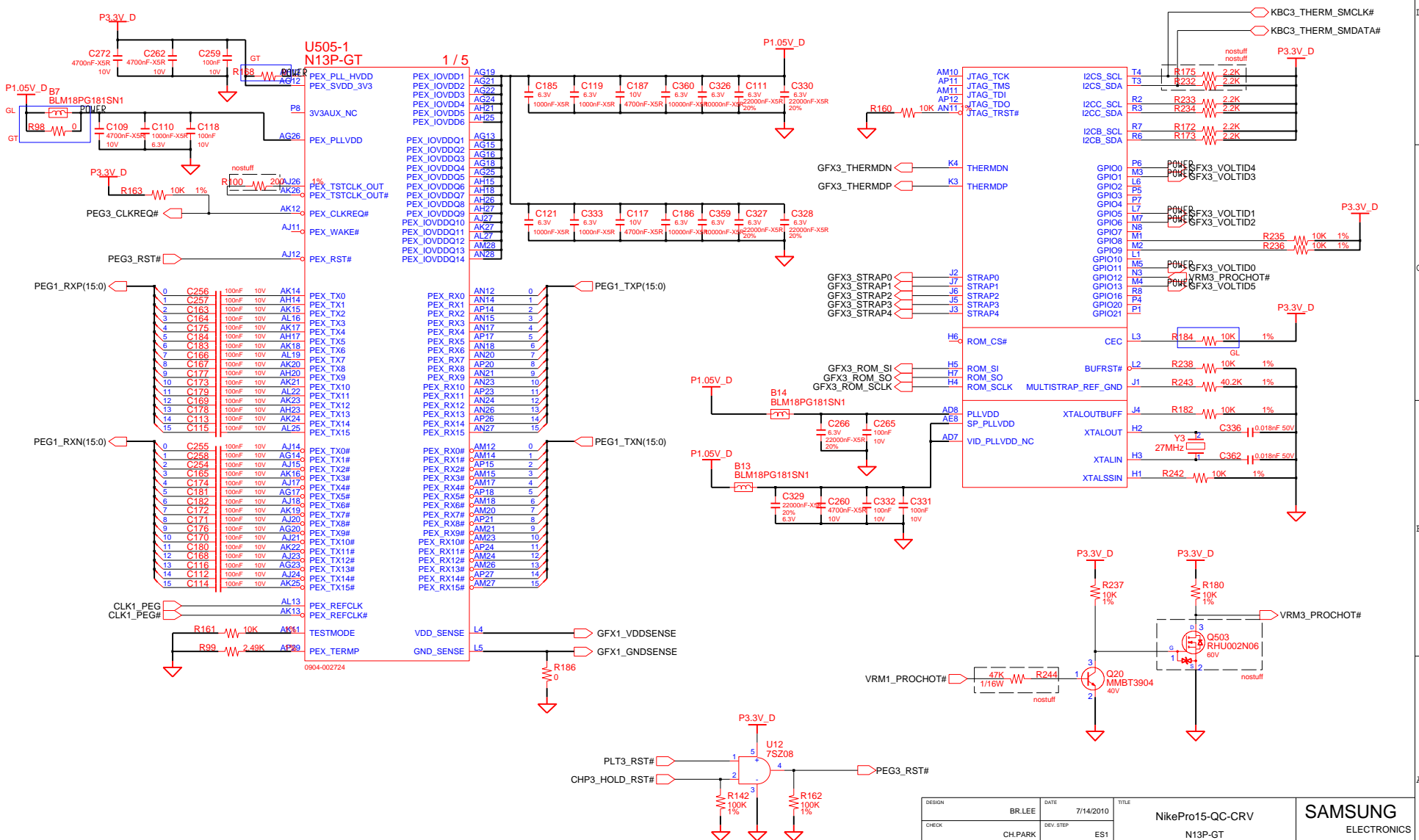

U505-1
N13P-GT
1 / 5

0904-002724

DESIGN	BR.LEE	DATE	7/14/2010	TITLE	NikePro15-QC-CRV	SAMSUNG ELECTRONICS
CHECK	CH.PARK	DEV.STEP	ES1		N13P-GT	
APPROVAL	KS.CHO	REV	REV 0.8		N13P-GT (1/5)	
MODULE CODE		LAST EDIT				PART NO. BA41-####A
May 13, 2011 10:03:37 AM						PAGE 27 OF 65

SAMSUNG PROPRIETARY
 THIS DOCUMENT CONTAINS CONFIDENTIAL
 PROPRIETARY INFORMATION THAT IS
 SAMSUNG ELECTRONICS CO.'S PROPERTY.
 DO NOT DISCLOSE TO OR DUPLICATE FOR OTHERS
 EXCEPT AS AUTHORIZED BY SAMSUNG.

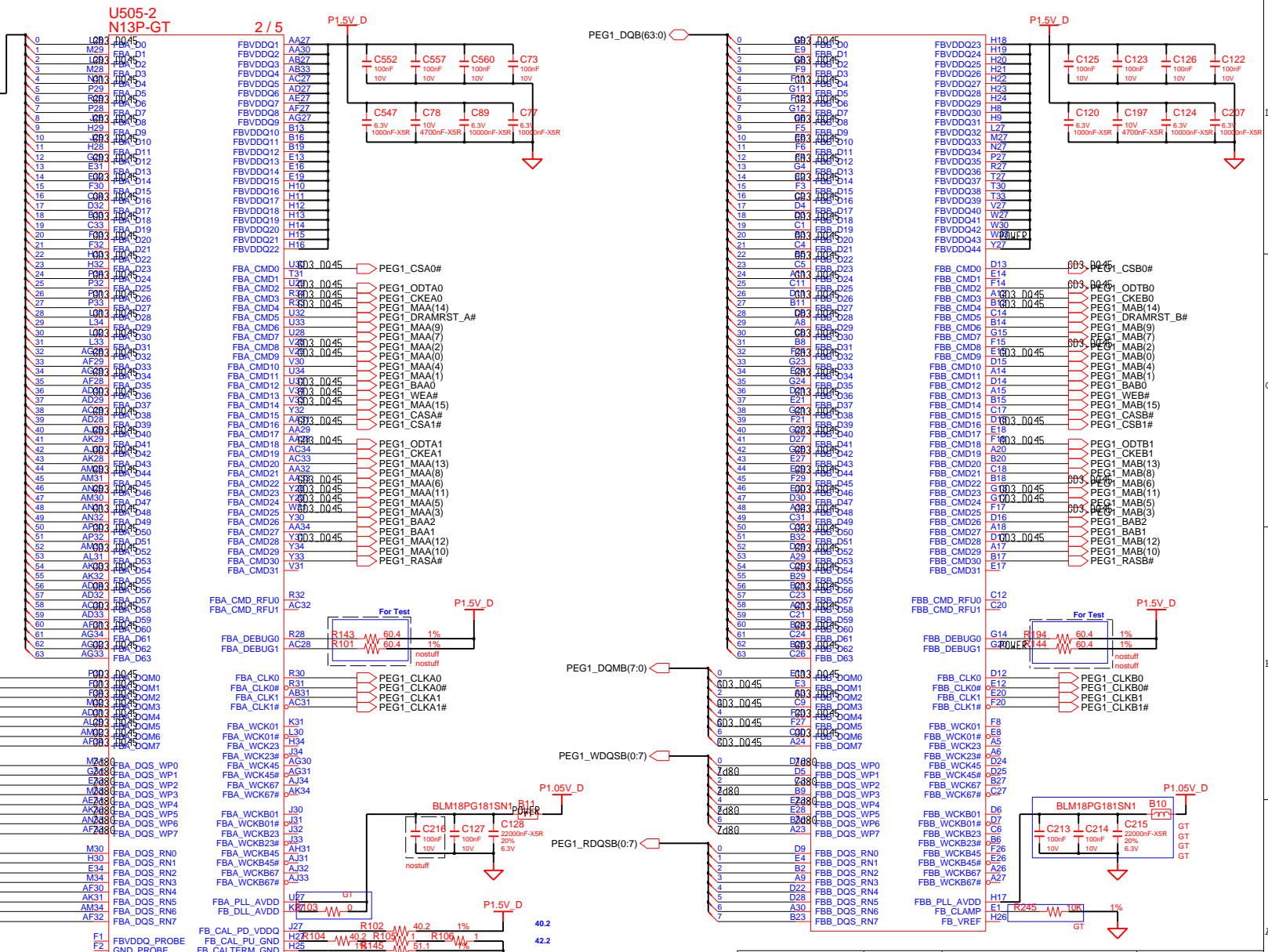

DESIGN	BR.LEE	DATE	7/14/2010	TITLE	NikePro15-QC-CRV	SAMSUNG
CHECK	CH.PARK	DEV. STEP	ES1		N13P-GT	ELECTRONICS
APPROVAL	KS.CHO	REV	REV 0.8		N13P-GT (2/5)	PART NO.
MODULE CODE		LAST EDIT				BA41-####A
			May 13, 2011 10:03:37 AM	PAGE	28	OF 65

SAMSUNG PROPRIETARY

THIS DOCUMENT CONTAINS CONFIDENTIAL
 PROPRIETARY INFORMATION THAT IS
 SAMSUNG ELECTRONICS CO.'S PROPERTY.
 DO NOT DISCLOSE TO OR DUPLICATE FOR OTHERS
 EXCEPT AS AUTHORIZED BY SAMSUNG.

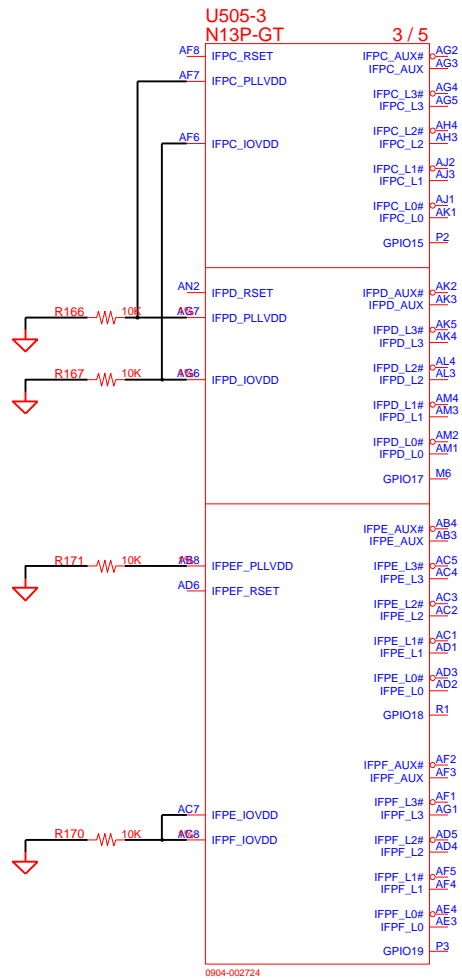

DESIGN	BR.LEE	DATE	7/14/2010	TITLE	NikePro15-QC-CRV	SAMSUNG ELECTRONICS
CHECK	CH.PARK	DEV.STEP	ES1		N13P-GT	
APPROVAL	KS.CHO	REV	REV 0.8		N13P-GT (3/5)	PART NO. BA41-####A
MODULE CODE		LAST EDIT	May 13, 2011 10:03:37 AM	PAGE	29	OF 65

SAMSUNG PROPRIETARY

THIS DOCUMENT CONTAINS CONFIDENTIAL
 PROPRIETARY INFORMATION THAT IS
 SAMSUNG ELECTRONICS CO.'S PROPERTY.
 DO NOT DISCLOSE TO OR DUPLICATE FOR OTHERS
 EXCEPT AS AUTHORIZED BY SAMSUNG.

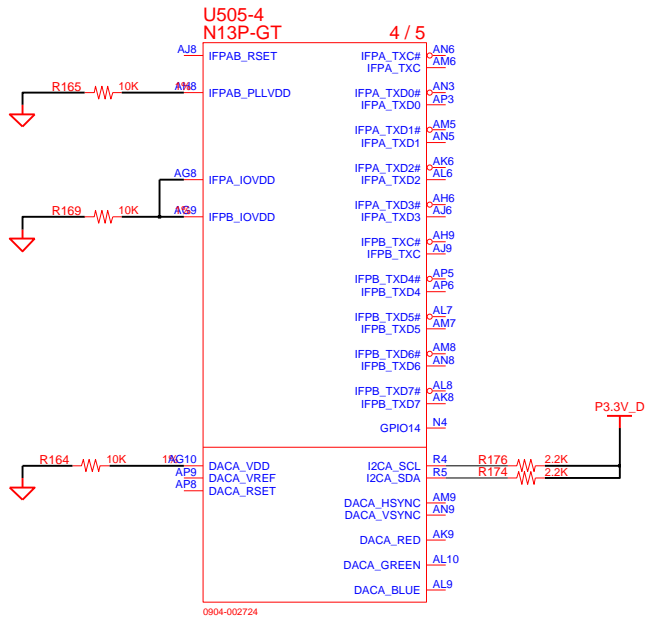

DESIGN	BR.LEE	DATE	7/14/2010	TITLE	NikePro15-QC-CRV N13P-GT N13P-GT (4/5)	SAMSUNG ELECTRONICS PART NO. BA41-####A
CHECK	CH.PARK	DEV.STEP	ES1			
APPROVAL	KS.CHO	REV	REV 0.8			
MODULE CODE		LAST EDIT		May 13, 2011 10:03:37 AM	PAGE	30 OF 65

SAMSUNG PROPRIETARY

THIS DOCUMENT CONTAINS CONFIDENTIAL
 PROPRIETARY INFORMATION THAT IS
 SAMSUNG ELECTRONICS CO.'S PROPERTY.
 DO NOT DISCLOSE TO OR DUPLICATE FOR OTHERS
 EXCEPT AS AUTHORIZED BY SAMSUNG.

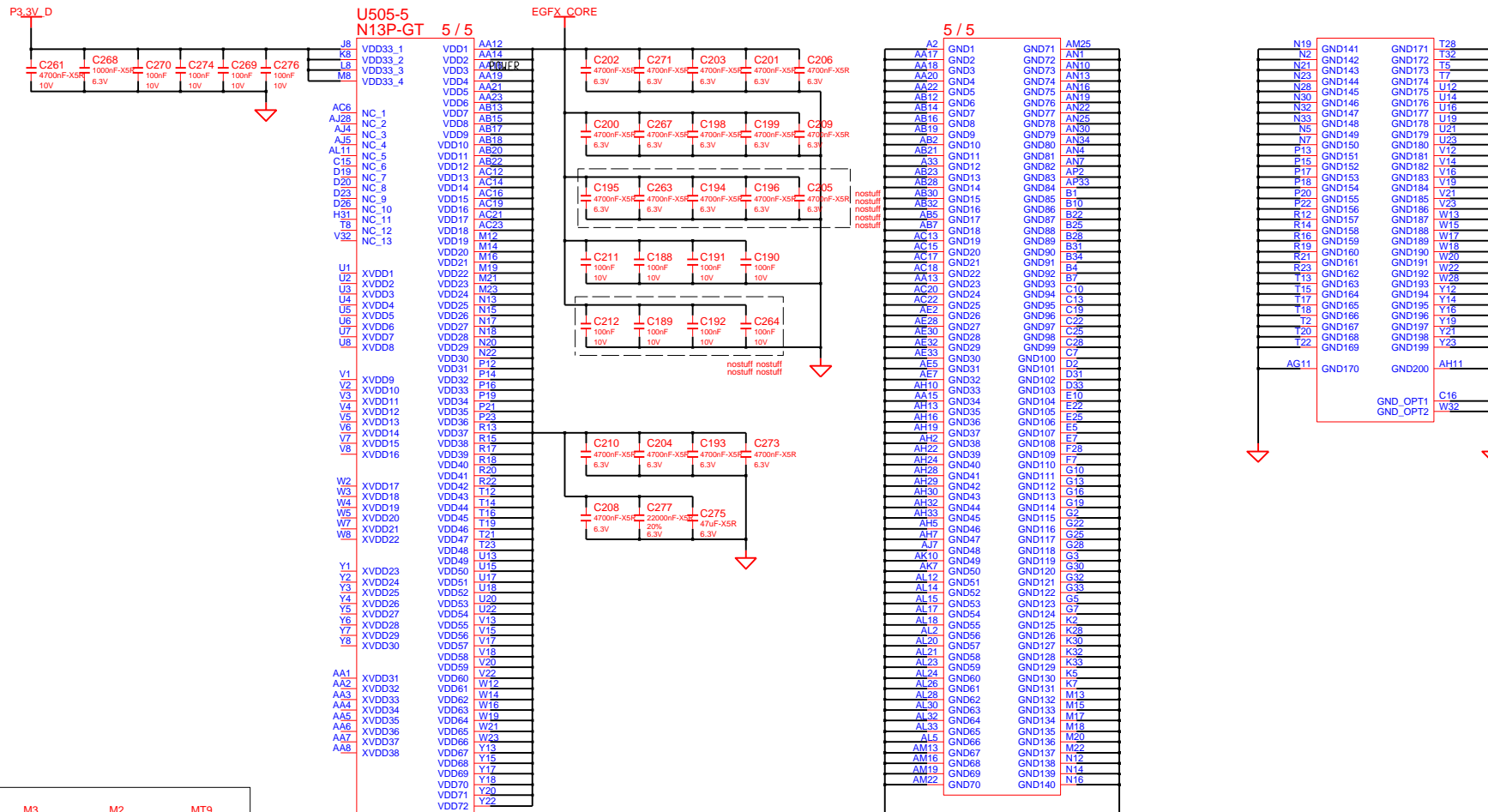

INT GFX and OPT GFX model need.

DESIGN	WK.YEO	DATE	7/14/2010	TITLE	NikePro15-QC	SAMSUNG ELECTRONICS PART NO. BA41-####A
CHECK	BW.YOO	DEV.STEP	Proto		N13P-GT	
APPROVAL	SH.LEE	REV	REV 0.8		N13P-GT (5/5)	
MODULE CODE		LAST EDIT				
				April 22, 2011 14:15:44 PM	PAGE	31 OF 66

SAMSUNG PROPRIETARY

THIS DOCUMENT CONTAINS CONFIDENTIAL PROPRIETARY INFORMATION THAT IS SAMSUNG ELECTRONICS CO.'S PROPERTY. DO NOT DISCLOSE TO OR DUPLICATE FOR OTHERS EXCEPT AS AUTHORIZED BY SAMSUNG.

N13x STRAP

Function Straps

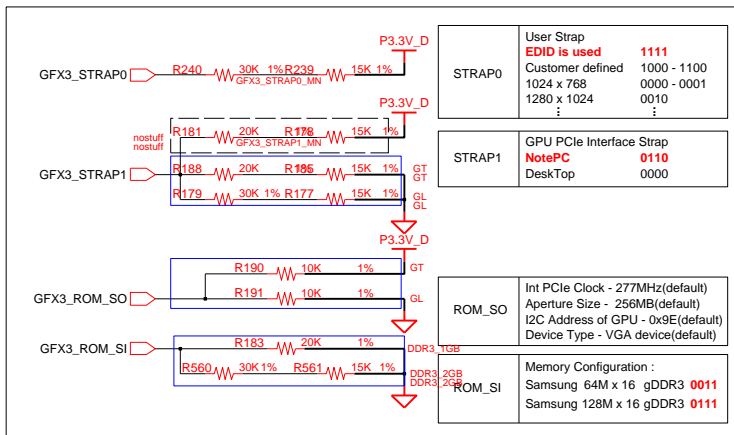

STRAP0	User Strap	EDID is used	1111
	Customer defined		1000 - 1100
			1024 x 768 0000 - 0001
STRAP1	GPU PCIe Interface Strap	NotePC	0110
	DeskTop		0000
ROM_SO	Int PCIe Clock - 277MHz(default)		
	Aperture Size - 256MB(default)		
ROM_SI	I2C Address of GPU - 0x9E(default)		
	Device Type - VGA device(default)		
	Memory Configuration :		
	Samsung 64M x 16 gDDR3	0011	
	Samsung 128M x 16 gDDR3	0111	

RESISTOR	PULL UP	PULL DOWN
5K	1000	0000
10K	1001	0001
15K	1010	0010
20K	1011	0011
25K	1100	0100
30K	1101	0101
35K	1110	0110
45K	1111	0111

STRAP PIN	BIT 3	BIT 2	BIT 1	BIT 0
STRAP0	USER[3]	USER[2]	USER[1]	USER[0]
STRAP1	3GIO_PADCFG[3]	3GIO_PADCFG[2]	3GIO_PADCFG[1]	3GIO_PADCFG[0]
ROM_SO	XCLK_417	FB_0_BAR_SIZE	SMB_ALT_ADDR	VGA_DEVICE
ROM_SI	RAMCFG[3]	RAMCFG[2]	RAMCFG[1]	RAMCFG[0]
STRAP2	PCI_DEVID[3]	PCI_DEVID[2]	PCI_DEVID[1]	PCI_DEVID[0]
ROM_SCLK	PCI_DEVID[4]	SUB_VENDOR	SLOT_CLK_CFG	PEX_PLL_EN_TERM

N13P-GT

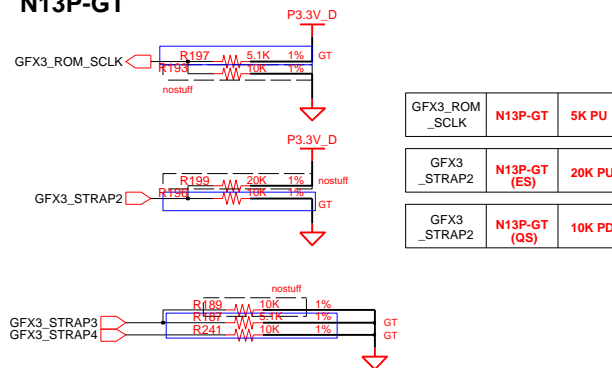

GFX3_ROM_SCLK	N13P-GT	5K PU
GFX3_STRAP2	N13P-GT (ES)	20K PU
GFX3_STRAP2	N13P-GT (QS)	10K PD

N13P-GL

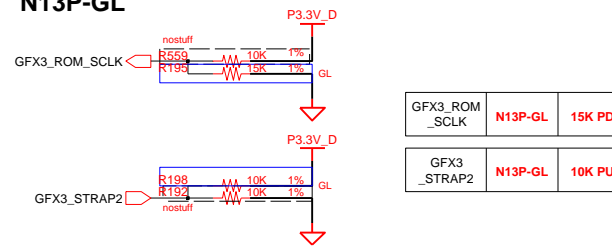

GFX3_ROM_SCLK	N13P-GL	15K PD
GFX3_STRAP2	N13P-GL	10K PU

DESIGN	WK.YEO	DATE	7/14/2010	TITLE	NikePro15-QC GRAPHIC STRAP GRAPHIC STRAP	SAMSUNG ELECTRONICS			
CHECK	BW.YOO	DEV. STEP	Proto						
APPROVAL	SH.LEE	REV	REV 0.8						
MODULE CODE		LAST EDIT							
April 22, 2011 14:15:44 PM						PAGE	32	OF	66

SAMSUNG PROPRIETARY

THIS DOCUMENT CONTAINS CONFIDENTIAL PROPRIETARY INFORMATION THAT IS SAMSUNG ELECTRONICS CO.'S PROPERTY. DO NOT DISCLOSE TO OR DUPLICATE FOR OTHERS EXCEPT AS AUTHORIZED BY SAMSUNG.

A-Channel #0 (D-mode)

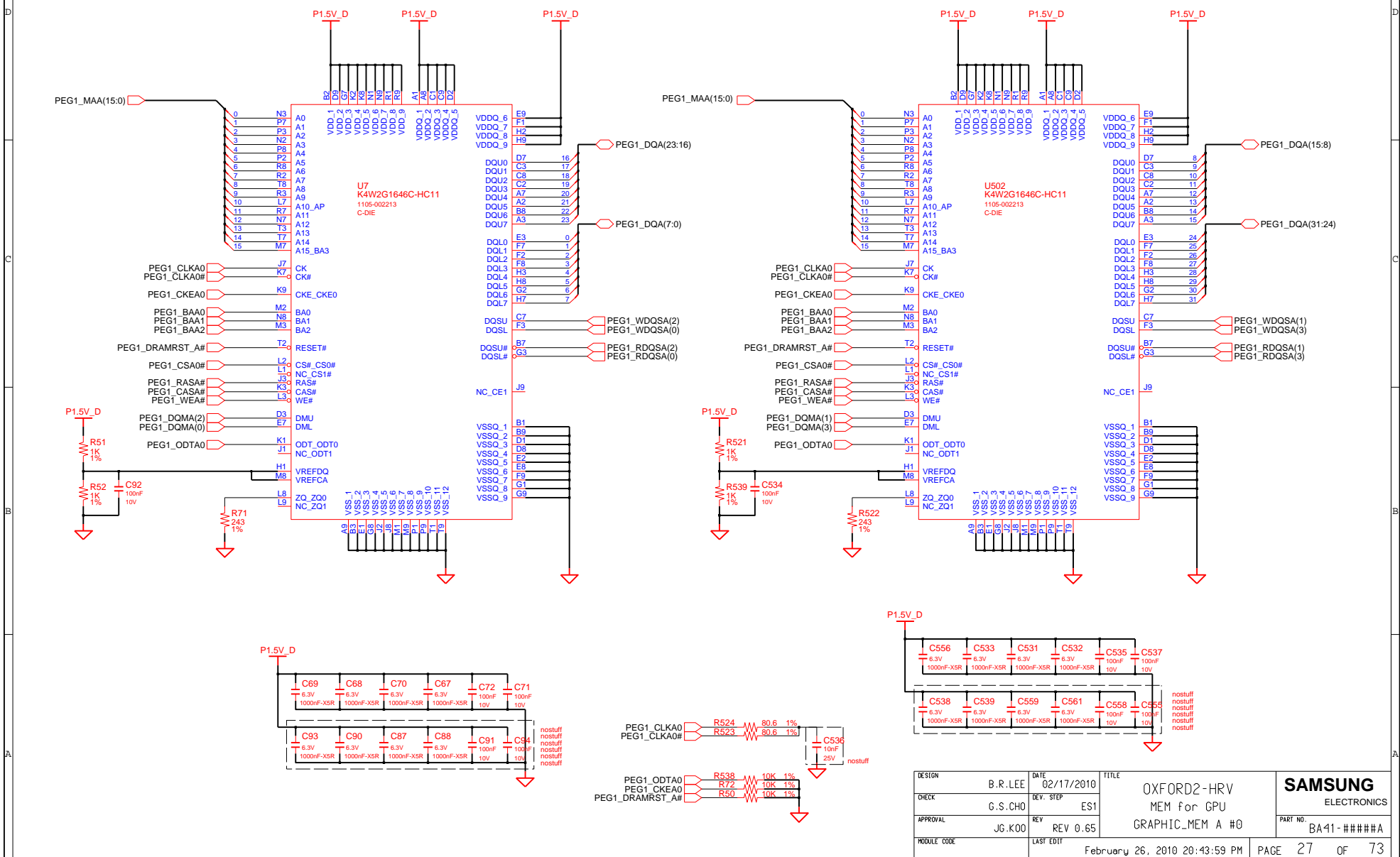

DESIGN	B.R.LEE	DATE	02/17/2010	TITLE	OXFORD2-HRV	SAMSUNG ELECTRONICS
CHECK	G.S.CHO	DEV. STEP	ES1		MEM for GPU	
APPROVAL	JG.KOO	REV	REV 0.65		GRAPHIC_MEM A #0	PART NO.
MODULE CODE		LAST EDIT		February 26, 2010 20:43:59 PM		BA41-#####A
				PAGE	27	OF 73

SAMSUNG PROPRIETARY

THIS DOCUMENT CONTAINS CONFIDENTIAL PROPRIETARY INFORMATION THAT IS SAMSUNG ELECTRONICS CO.'S PROPERTY. DO NOT DISCLOSE TO OR DUPLICATE FOR OTHERS EXCEPT AS AUTHORIZED BY SAMSUNG.

A-Channel #1 (D-mode)

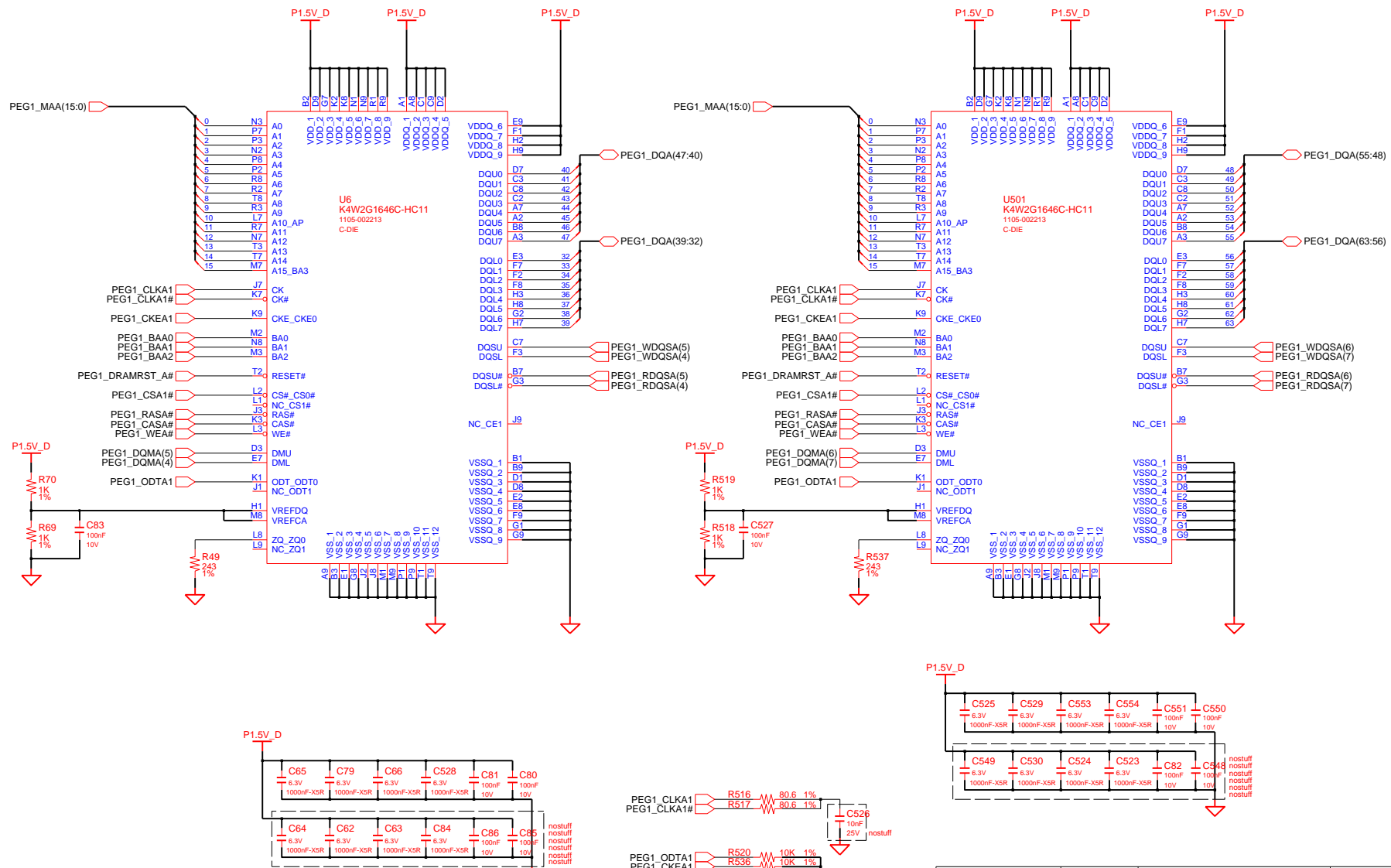

DESIGN	B.R.LEE	DATE	02/17/2010	TITLE	OXFORD2-HRV	SAMSUNG ELECTRONICS
CHECK	G.S.CHO	DEV. STEP	ES1		MEM for GPU	
APPROVAL	JG.KOO	REV	REV 0.65		GRAPHIC_MEM A #1	PART NO.
MODULE CODE		LAST EDIT	February 26, 2010 20:43:59 PM	PAGE	28	OF 73

SAMSUNG PROPRIETARY

THIS DOCUMENT CONTAINS CONFIDENTIAL PROPRIETARY INFORMATION THAT IS SAMSUNG ELECTRONICS CO.'S PROPERTY. DO NOT DISCLOSE TO OR DUPLICATE FOR OTHERS EXCEPT AS AUTHORIZED BY SAMSUNG.

B-Channel #0 (D-mode)

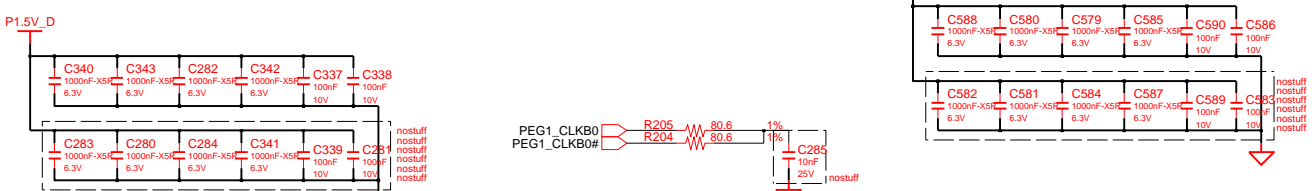
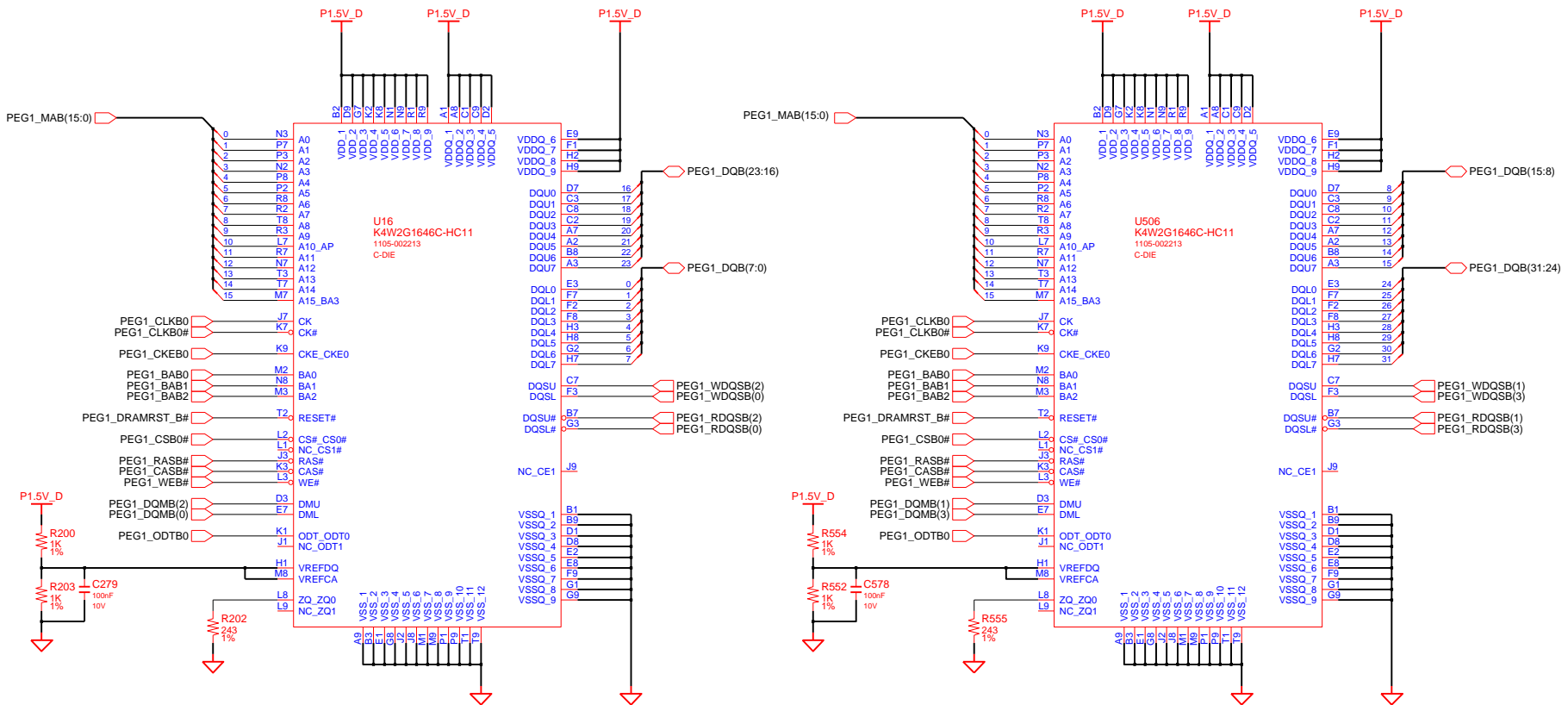

DESIGN	B.R.LEE	DATE	02/17/2010	TITLE	OXFORD2-HRV	SAMSUNG ELECTRONICS
CHECK	G.S.CHO	DEV. STEP	ES1		MEM for GPU	
APPROVAL	JG.KOO	REV	REV 0.65		GRAPHIC_MEM B #0	PART NO. BA41-#####A
MODULE CODE		LAST EDIT	February 26, 2010 20:43:59 PM	PAGE	29	OF 73

SAMSUNG PROPRIETARY

THIS DOCUMENT CONTAINS CONFIDENTIAL PROPRIETARY INFORMATION THAT IS SAMSUNG ELECTRONICS CO.'S PROPERTY. DO NOT DISCLOSE TO OR DUPLICATE FOR OTHERS EXCEPT AS AUTHORIZED BY SAMSUNG.

B-Channel #1 (D-mode)

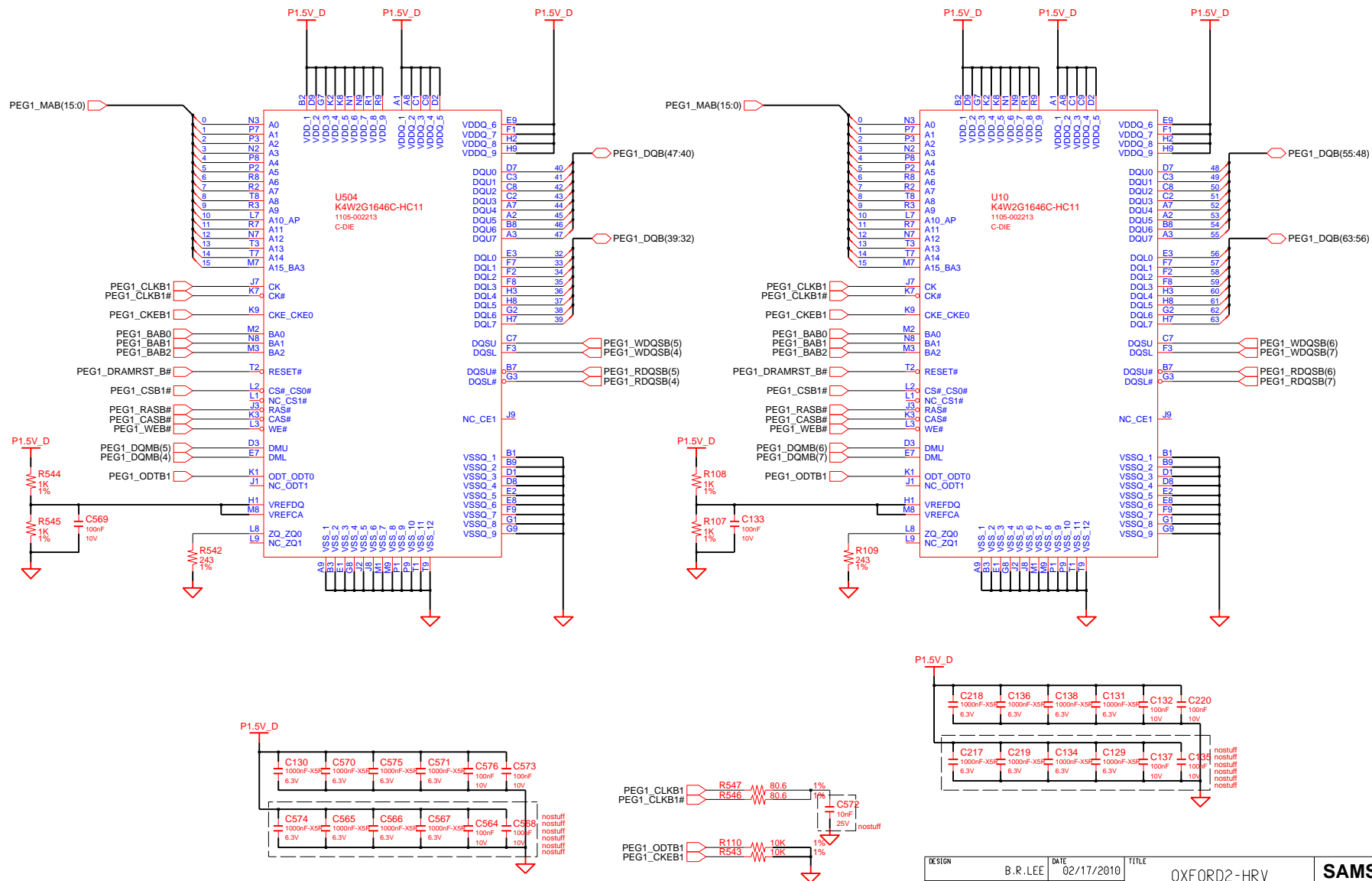

DESIGN	B.R.LEE	DATE	02/17/2010	TITLE	OXFORD2-HRV	SAMSUNG ELECTRONICS
CHECK	G.S.CHO	DEV. STEP	ES1		MEM for GPU	
APPROVAL	JG.KOO	REV	REV 0.65		GRAPHIC_MEM B #1	PART NO.
MODULE CODE		LAST EDIT	February 26, 2010 20:43:59 PM	PAGE	30	OF 73

SAMSUNG PROPRIETARY

THIS DOCUMENT CONTAINS CONFIDENTIAL
PROPRIETARY INFORMATION THAT IS
SAMSUNG ELECTRONICS CO.'S PROPERTY.
DO NOT DISCLOSE TO OR DUPLICATE FOR OTHERS
EXCEPT AS AUTHORIZED BY SAMSUNG.

D

D

C

C

B

B

A

A

DESIGN	B.R.LEE	DATE	02/17/2010	TITLE	OXFORD2-HRV	SAMSUNG ELECTRONICS
CHECK	G.S.CHO	DEV. STEP	ES1			
APPROVAL	JG.KOO	REV	REV 0.65	PART NO.	BA41-####A	
MODULE CODE		LAST EDIT	February 26, 2010 20:43:59 PM	PAGE	31	OF 73

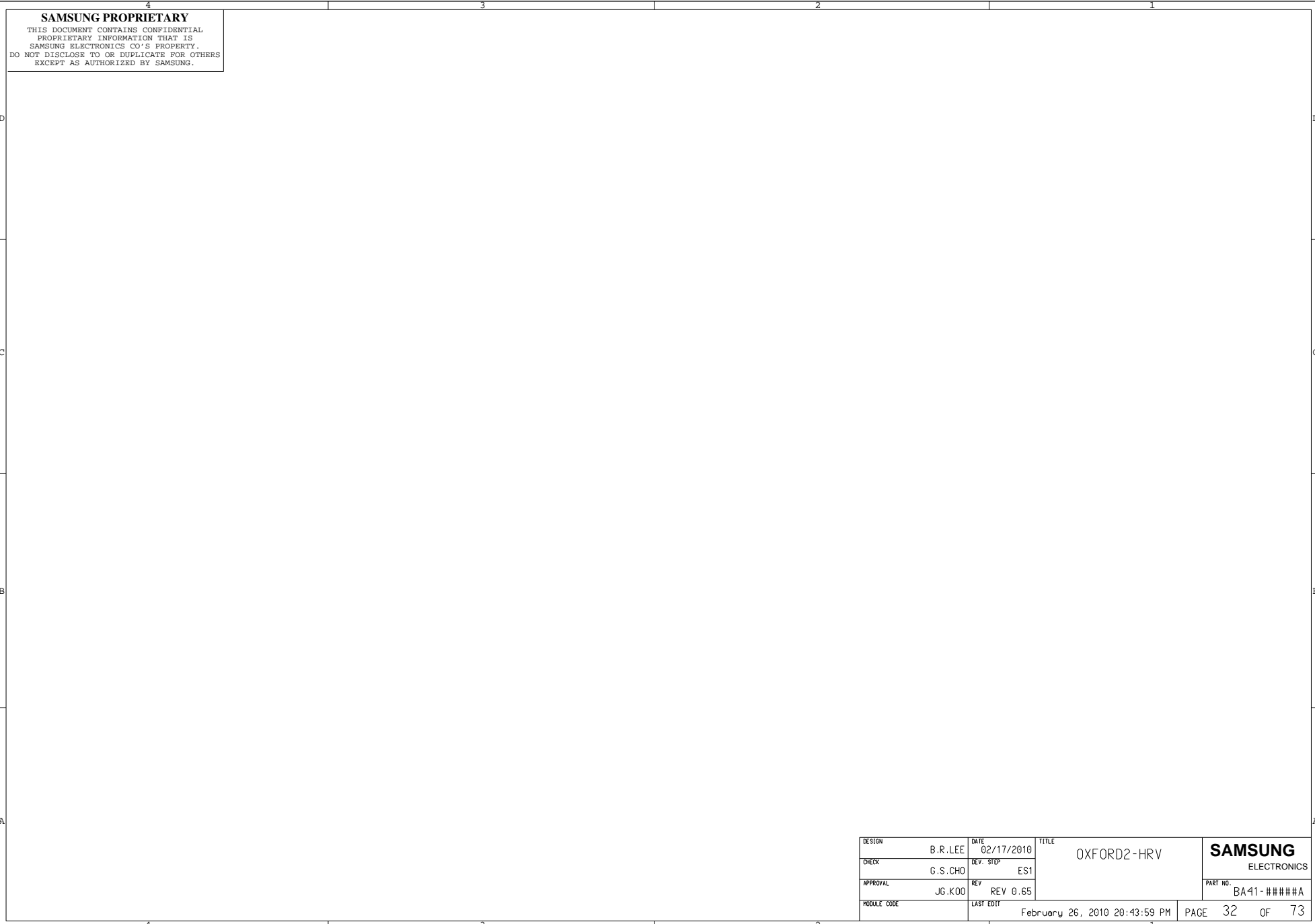

SAMSUNG PROPRIETARY

THIS DOCUMENT CONTAINS CONFIDENTIAL
PROPRIETARY INFORMATION THAT IS
SAMSUNG ELECTRONICS CO.'S PROPERTY.
DO NOT DISCLOSE TO OR DUPLICATE FOR OTHERS
EXCEPT AS AUTHORIZED BY SAMSUNG.

DESIGN	B.R.LEE	DATE	02/17/2010	TITLE	OXFORD2-HRV	SAMSUNG ELECTRONICS
CHECK	G.S.CHO	DEV. STEP	ES1			
APPROVAL	JG.KOO	REV	REV 0.65			PART NO. BA41-####A
MODULE CODE		LAST EDIT	February 26, 2010 20:43:59 PM	PAGE	32	OF 73

SAMSUNG PROPRIETARY

THIS DOCUMENT CONTAINS CONFIDENTIAL
PROPRIETARY INFORMATION THAT IS
SAMSUNG ELECTRONICS CO.'S PROPERTY.
DO NOT DISCLOSE TO OR DUPLICATE FOR OTHERS
EXCEPT AS AUTHORIZED BY SAMSUNG.

D

D

C

C

B

B

A

A

DESIGN	B.R.LEE	DATE	02/17/2010	TITLE	OXFORD2-HRV	SAMSUNG ELECTRONICS
CHECK	G.S.CHO	DEV. STEP	ES1			
APPROVAL	JG.KOO	REV	REV 0.65	PART NO.	BA41-####A	
MODULE CODE	LAST EDIT		February 26, 2010 20:43:59 PM	PAGE	33	OF 73

SAMSUNG PROPRIETARY

THIS DOCUMENT CONTAINS CONFIDENTIAL
PROPRIETARY INFORMATION THAT IS
SAMSUNG ELECTRONICS CO.'S PROPERTY.
DO NOT DISCLOSE TO OR DUPLICATE FOR OTHERS
EXCEPT AS AUTHORIZED BY SAMSUNG.

D

C

B

A

D

C

B

A

DESIGN	B.R.LEE	DATE	02/17/2010	TITLE	OXFORD2-HRV	SAMSUNG ELECTRONICS	
CHECK	G.S.CHO	DEV. STEP	ES1				
APPROVAL	JG.KOO	REV	REV 0.65	PART NO.	BA41-####A		
MODULE CODE		LAST EDIT	February 26, 2010 20:43:59 PM	PAGE	34	OF	73

SAMSUNG PROPRIETARY

THIS DOCUMENT CONTAINS CONFIDENTIAL PROPRIETARY INFORMATION THAT IS SAMSUNG ELECTRONICS CO.'S PROPERTY. DO NOT DISCLOSE TO OR DUPLICATE FOR OTHERS EXCEPT AS AUTHORIZED BY SAMSUNG.

LVDS LOGIC

Backlight On

2Ch. LCD Connector + CAMERA

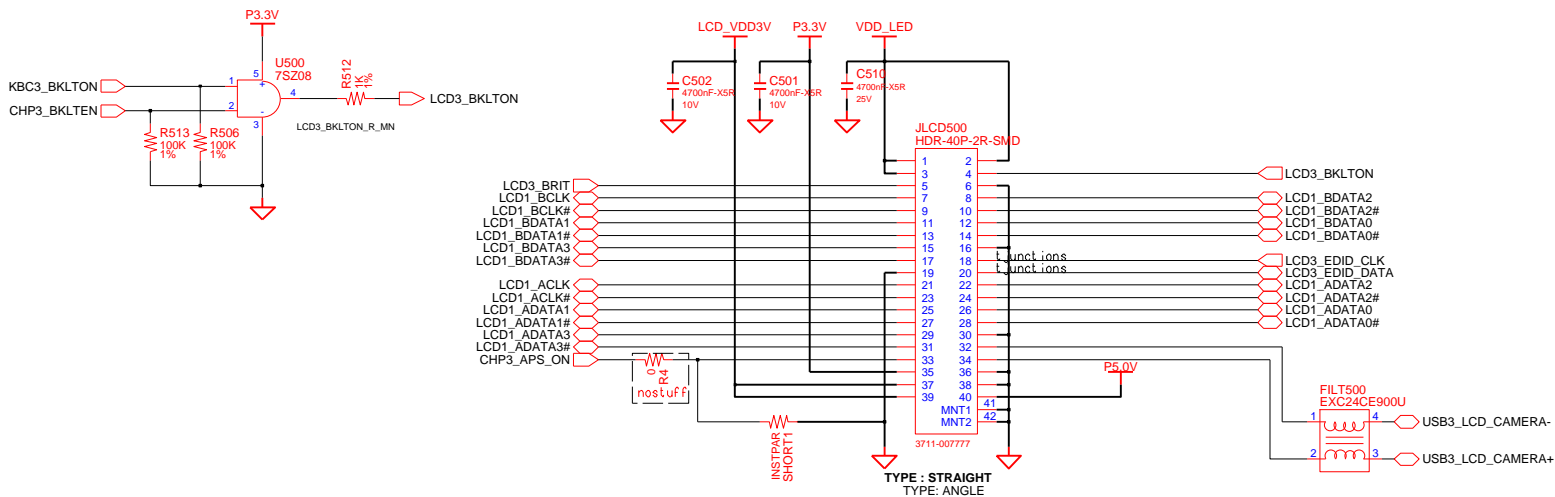

LCD Power

EBL Purpose

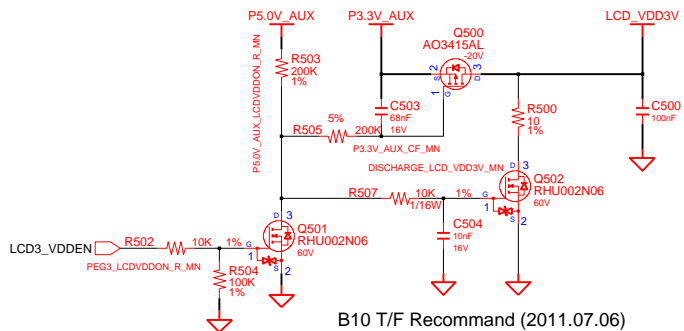

B10 T/F Reccomand (2011.07.06)

LED Power

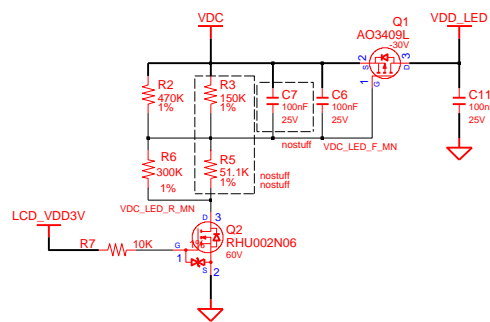

DESIGN	MS YANG	DATE	3/11/2011	TITLE	PETRONAS-15_QUAD	SAMSUNG ELECTRONICS
CHECK	MK KIM	DEV.STEP	PR	GRAPHICS_IF	PART NO.	
APPROVAL	BL LEE	REV	REV 1.0	LVDS	BA41-01662A	
MODULE CODE		LAST EDIT				
				May 20, 2011 21:14:43 PM	PAGE	27 OF 51

SAMSUNG PROPRIETARY

THIS DOCUMENT CONTAINS CONFIDENTIAL
 PROPRIETARY INFORMATION THAT IS
 SAMSUNG ELECTRONICS CO.'S PROPERTY.
 DO NOT DISCLOSE TO OR DUPLICATE FOR OTHERS
 EXCEPT AS AUTHORIZED BY SAMSUNG.

80H PORT DEBUG

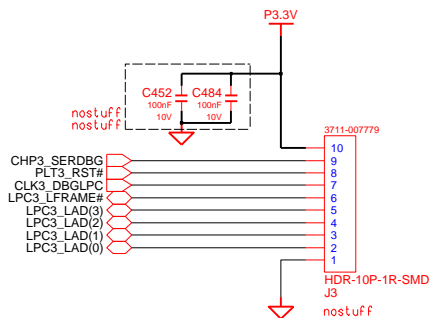

DESIGN	MS YANG	DATE	3/11/2011	TITLE	PETRONAS-15_QUAD GRAPHICS_IF	SAMSUNG ELECTRONICS
CHECK	MK KIM	DEV. STEP	PR			
APPROVAL	BL LEE	REV	REV 1.0		LVDS	PART NO. BA41-01662A
MODULE CODE		LAST EDIT	May 20, 2011 21:14:43 PM	PAGE	27	OF 51

SAMSUNG PROPRIETARY

THIS DOCUMENT CONTAINS CONFIDENTIAL PROPRIETARY INFORMATION THAT IS SAMSUNG ELECTRONICS CO.'S PROPERTY. DO NOT DISCLOSE TO OR DUPLICATE FOR OTHERS EXCEPT AS AUTHORIZED BY SAMSUNG.

CRT LOGIC

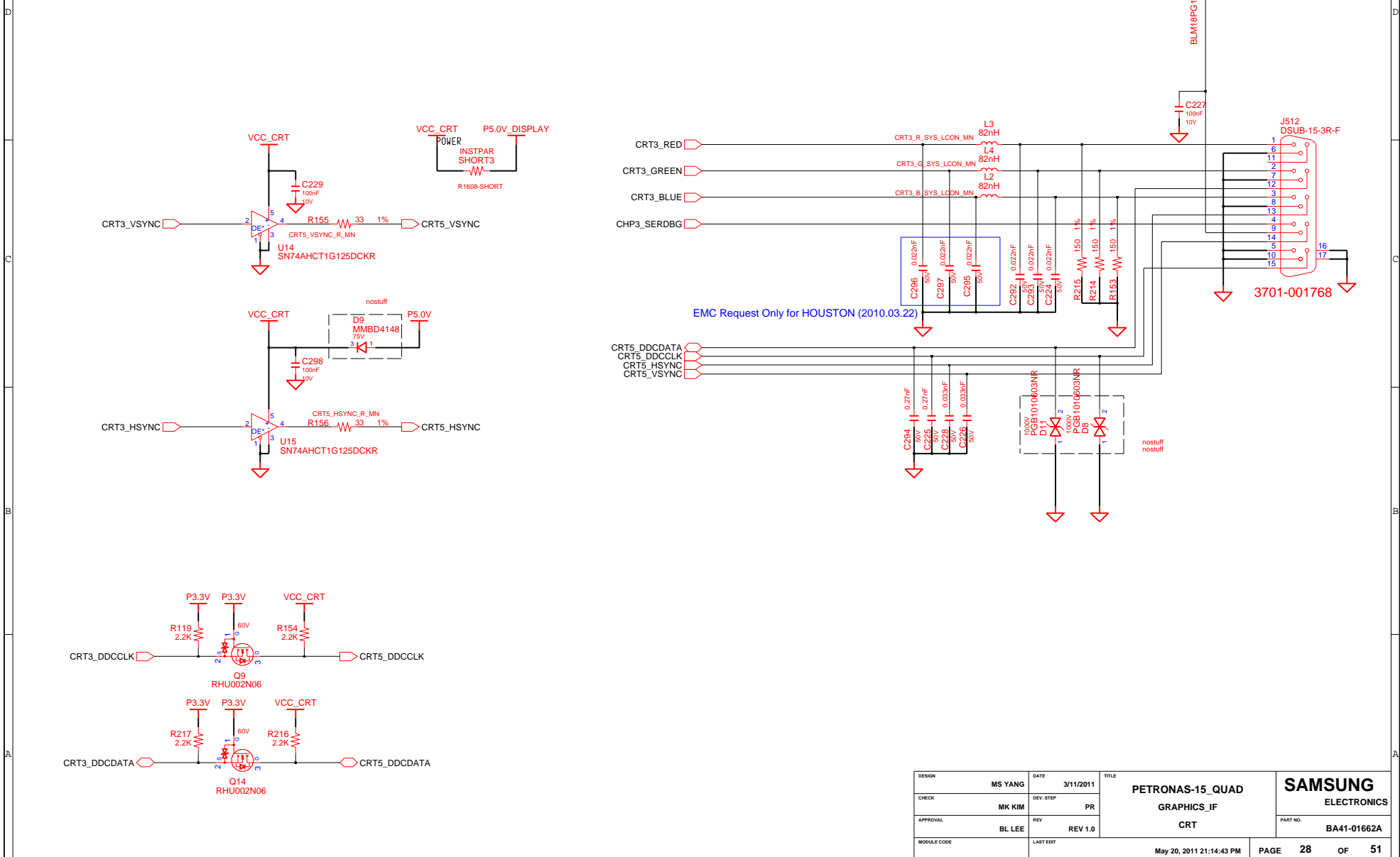

DESIGN	MS YANG	DATE	3/11/2011	TITLE	PETRONAS-15_QUAD GRAPHICS_IF CRT	SAMSUNG ELECTRONICS PART NO: BA41-01662A
CHECK	MK KIM	DEV. STEP	PR			
APPROVAL	BL LEE	REV	REV 1.0			
MODULE CODE		LAST EDIT				
				May 20, 2011 21:14:43 PM	PAGE	28 OF 51

SAMSUNG PROPRIETARY

THIS DOCUMENT CONTAINS CONFIDENTIAL PROPRIETARY INFORMATION THAT IS SAMSUNG ELECTRONICS CO.'S PROPERTY. DO NOT DISCLOSE TO OR DUPLICATE FOR OTHERS EXCEPT AS AUTHORIZED BY SAMSUNG.

HDMI Graphic

After checking, Houston need to use CMC for each signal.

(EMC request at 2010.04.15)

After checking, Veyron_R don't need to use CMC for each signal.

(EMC request at 2010.12.03)

STANDARD NET NAME

Display from PCH	Display from GPU
PCH3_HDMI_XXX	PEG3_HDMI_XXX
PCH1_XXXX_HDMI	PEG3_XXXX_HDMI

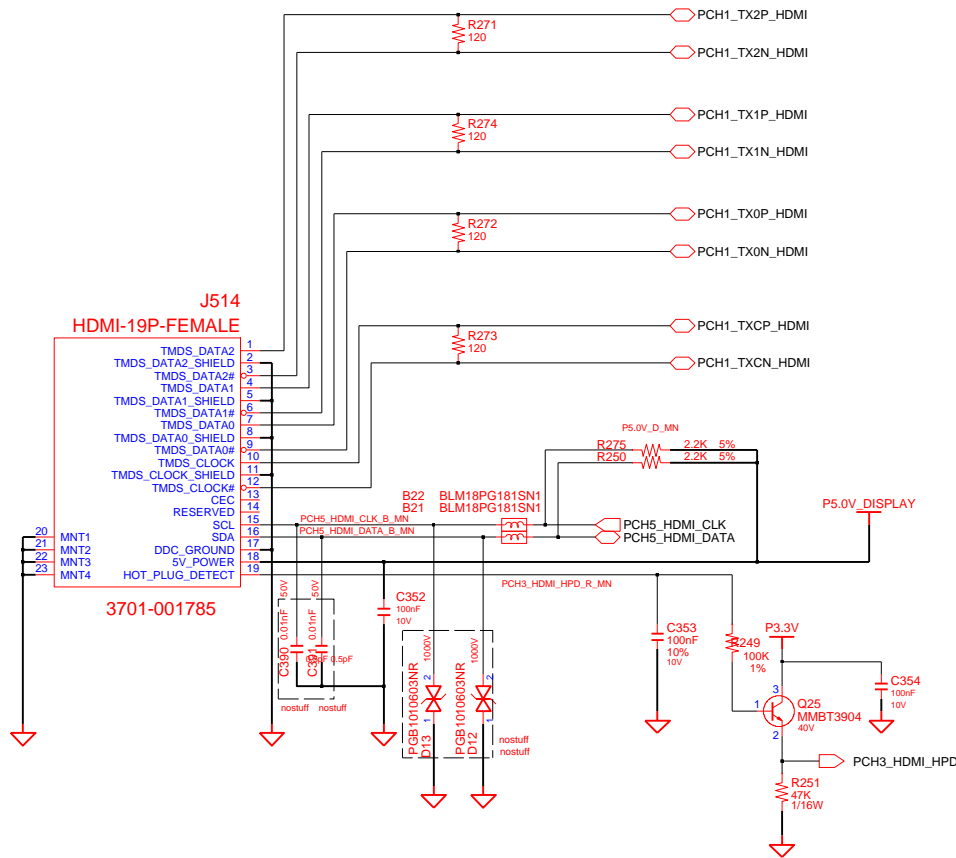
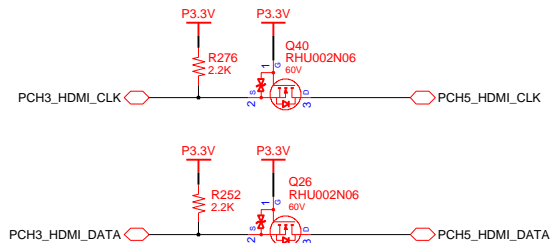

DESIGN	MS YANG	DATE	3/11/2011	TITLE	PETRONAS-15_QUAD	SAMSUNG ELECTRONICS
CHECK	MK KIM	DEV.STEP	PR	GRAPHICS_IF	PART NO.	
APPROVAL	BL LEE	REV	REV 1.0	HDMI	BA41-01662A	
MODULE CODE		LAST EDIT	May 20, 2011 21:14:43 PM	PAGE	29	OF 51

SAMSUNG PROPRIETARY

THIS DOCUMENT CONTAINS CONFIDENTIAL PROPRIETARY INFORMATION THAT IS SAMSUNG ELECTRONICS CO.'S PROPERTY. DO NOT DISCLOSE TO OR DUPLICATE FOR OTHERS EXCEPT AS AUTHORIZED BY SAMSUNG.

Codec Pin9 Setting	
S/B with Low Voltage IO	S/B without Low Voltage IO
Pin9 : 1.5V	Pin9 : 3.3V

HD AUDIO

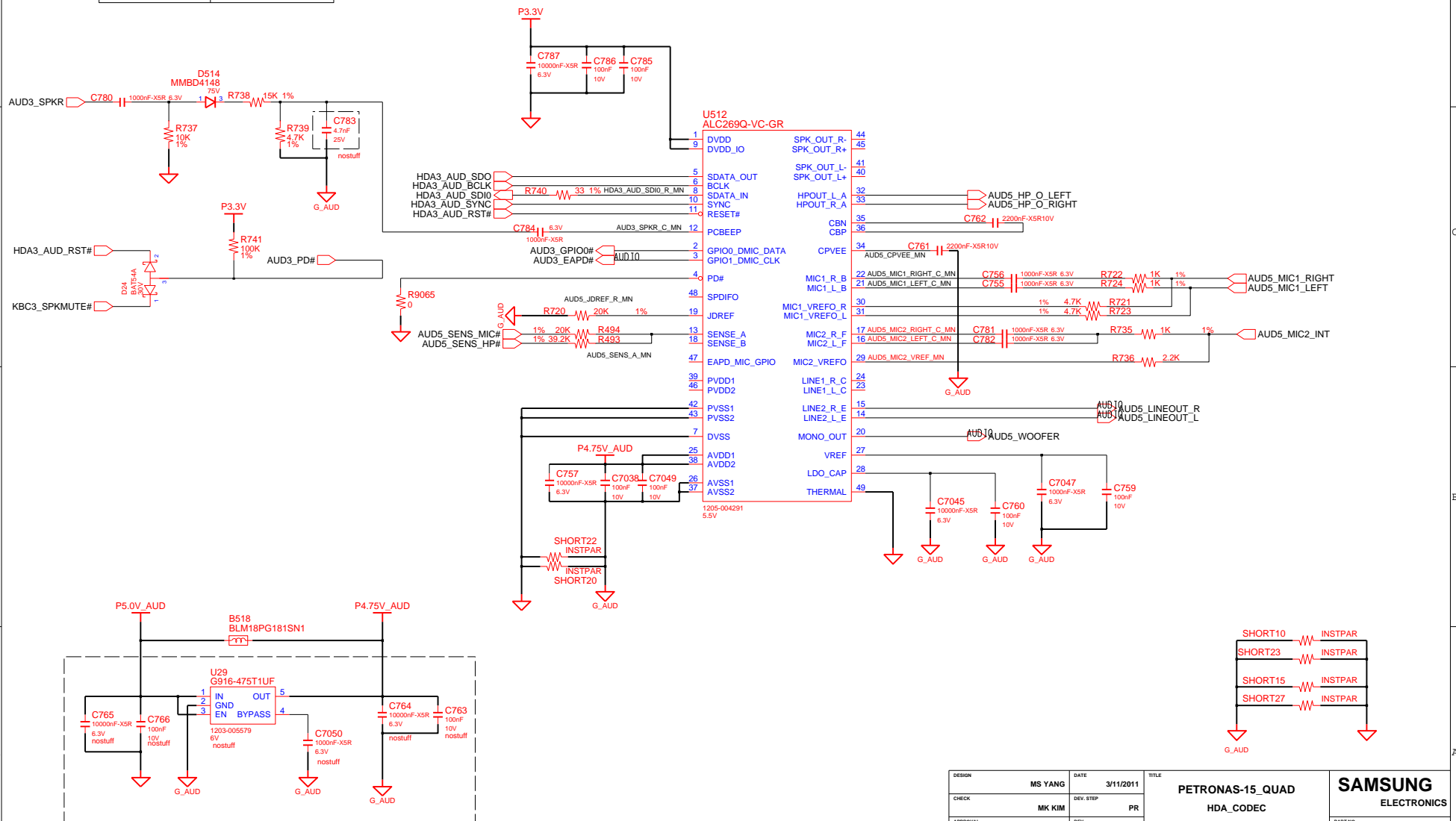

DESIGN	MS YANG	DATE	3/11/2011	TITLE	PETRONAS-15_QUAD HDA_CODEC AUDIO CODEC ALC269	SAMSUNG ELECTRONICS
CHECK	MK KIM	DEV. STEP	PR			PART NO. BA41-01662A
APPROVAL	BL LEE	REV	REV 1.0			
MODULE CODE		LAST EDIT		May 20, 2011 21:14:43 PM	PAGE 30 OF 51	

SAMSUNG PROPRIETARY
 THIS DOCUMENT CONTAINS CONFIDENTIAL
 PROPRIETARY INFORMATION THAT IS
 SAMSUNG ELECTRONICS CO.'S PROPERTY.
 DO NOT DISCLOSE TO OR DUPLICATE FOR OTHERS
 EXCEPT AS AUTHORIZED BY SAMSUNG.

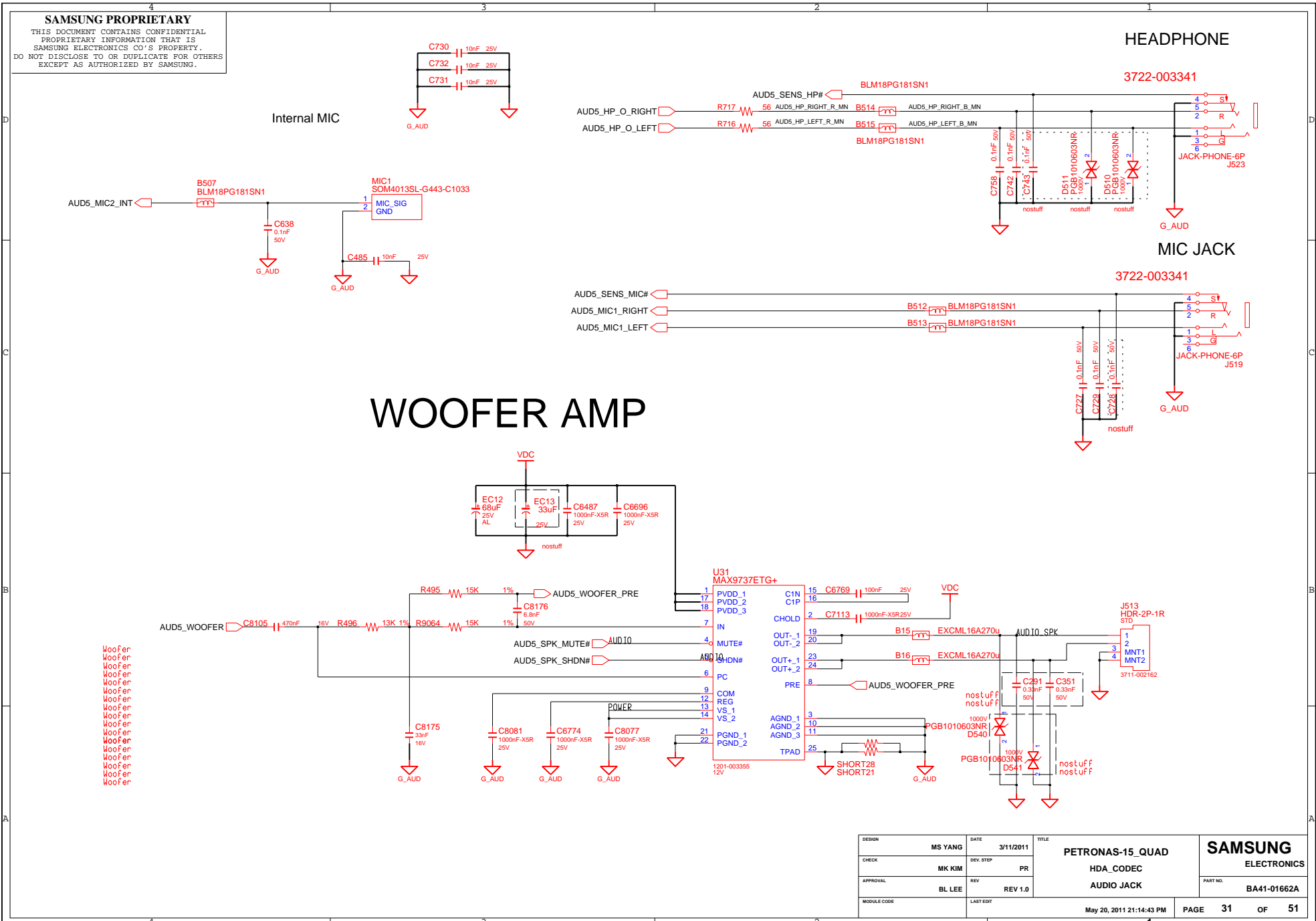

DESIGN	MS YANG	DATE	3/11/2011	TITLE	PETRONAS-15_QUAD	SAMSUNG ELECTRONICS
CHECK	MK KIM	DEV. STEP	PR		HDA_CODEC	
APPROVAL	BL LEE	REV	REV 1.0		AUDIO JACK	
MODULE CODE		LAST EDIT				PART NO. BA41-01662A
May 20, 2011 21:14:43 PM						PAGE 31 OF 51

SAMSUNG PROPRIETARY

THIS DOCUMENT CONTAINS CONFIDENTIAL PROPRIETARY INFORMATION THAT IS SAMSUNG ELECTRONICS CO.'S PROPERTY. DO NOT DISCLOSE TO OR DUPLICATE FOR OTHERS EXCEPT AS AUTHORIZED BY SAMSUNG.

3711-007614|53398-0490-4m_ng

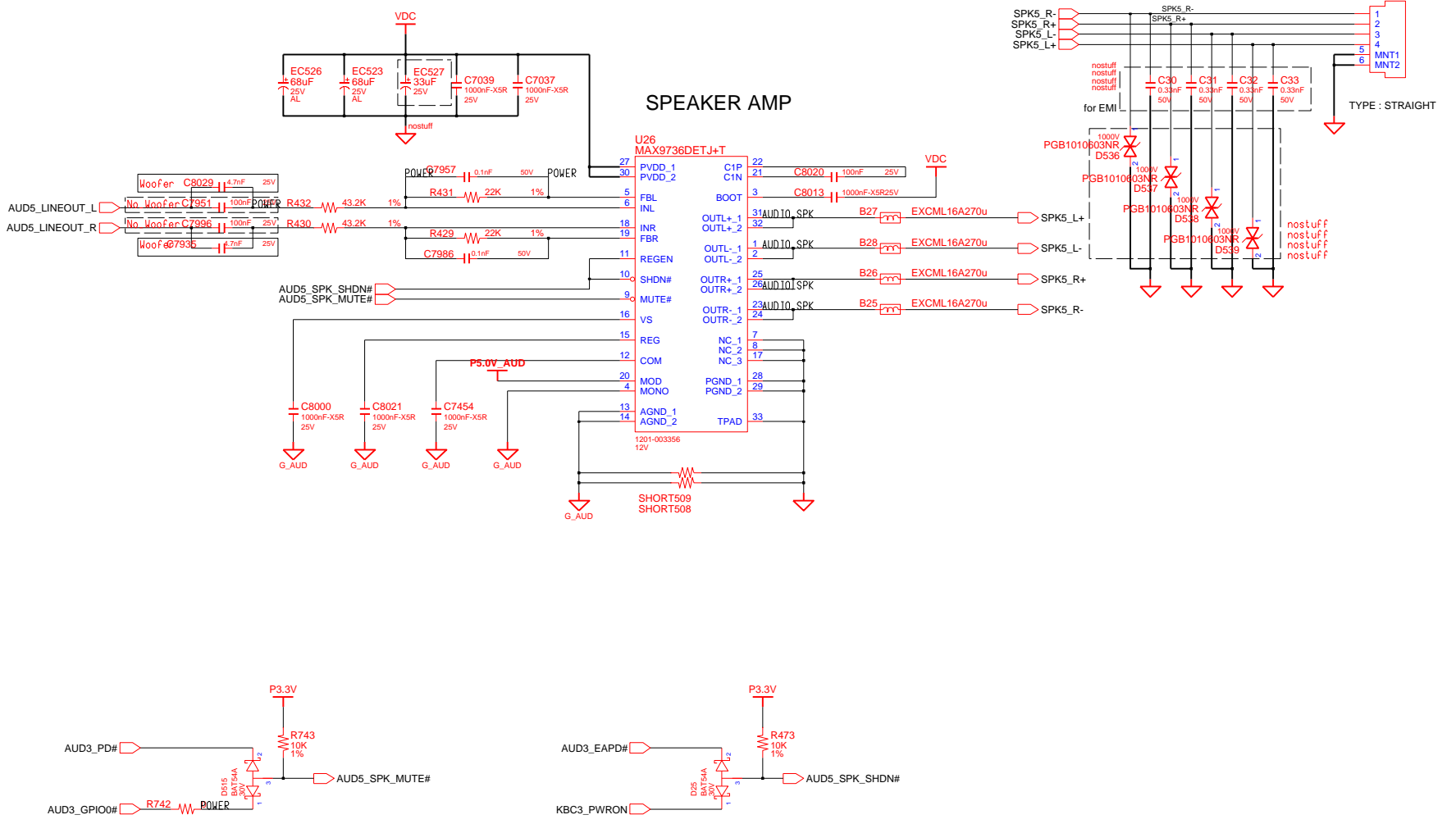

DESIGN	DATE	TITLE	SAMSUNG ELECTRONICS PART NO. BA41-undef i
CHECK	8/5/2011	McLaren-15 Audio Speaker AMP	
APPROVAL	DEV. STEP UNDEFINED		
MODULE CODE	REV UNDEFINED		
LAST EDIT		October, 7, 2011 2:49:44 PM	PAGE 39 OF

SAMSUNG PROPRIETARY

THIS DOCUMENT CONTAINS CONFIDENTIAL PROPRIETARY INFORMATION THAT IS SAMSUNG ELECTRONICS CO.'S PROPERTY. DO NOT DISCLOSE TO OR DUPLICATE FOR OTHERS EXCEPT AS AUTHORIZED BY SAMSUNG.

Reatek RTL8111E

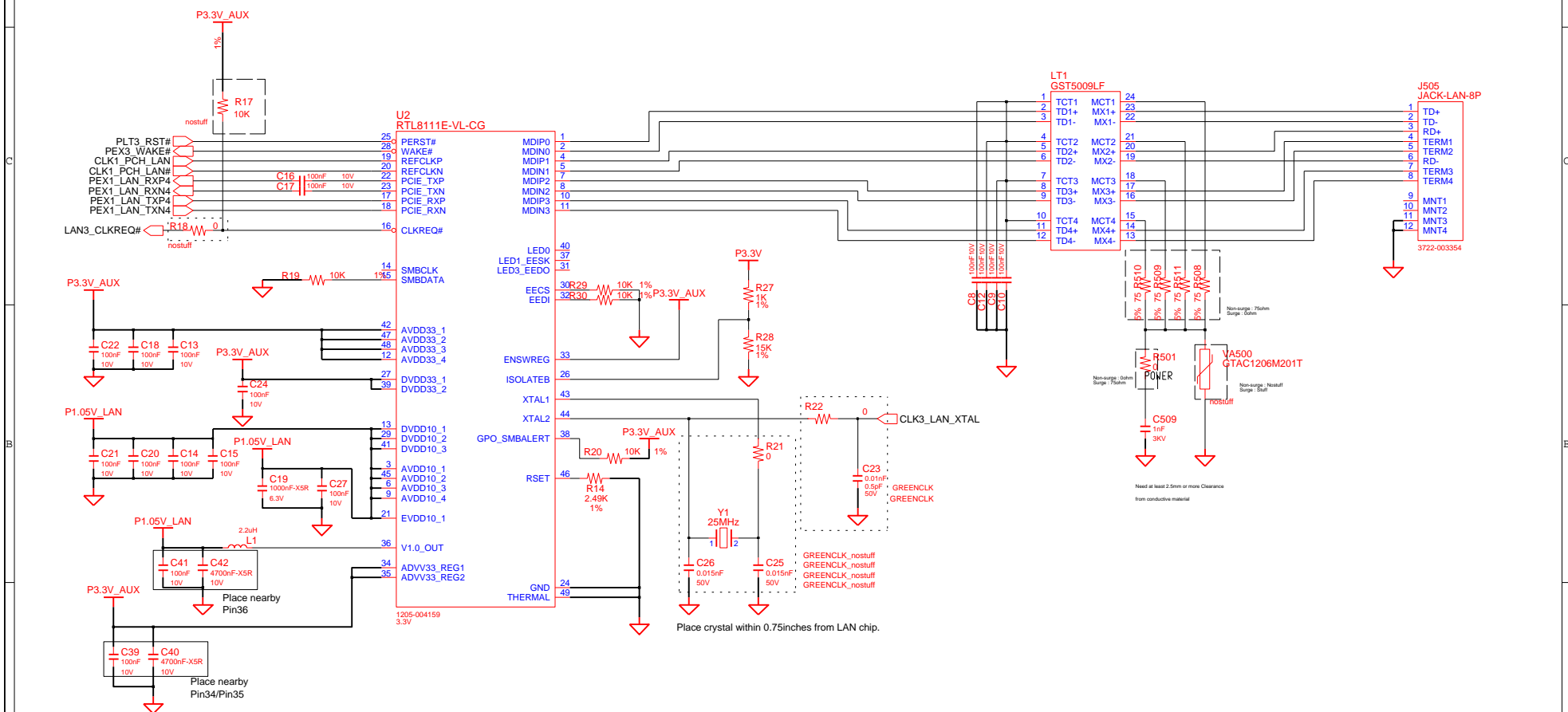

DESIGN	MS YANG	DATE	3/11/2011	TITLE	PETRONAS-15_QUAD LAN LAN_Realttek_RTL8111	SAMSUNG ELECTRONICS PART NO: BA41-01662A
CHECK	MK KIM	DEV. STEP	PR			
APPROVAL	BL LEE	REV	REV 1.0			
MODULE CODE		LAST EDIT				
				May 20, 2011 21:14:43 PM	PAGE	32 OF 51

SAMSUNG PROPRIETARY

THIS DOCUMENT CONTAINS CONFIDENTIAL PROPRIETARY INFORMATION THAT IS SAMSUNG ELECTRONICS CO.'S PROPERTY. DO NOT DISCLOSE TO OR DUPLICATE FOR OTHERS EXCEPT AS AUTHORIZED BY SAMSUNG.

4 IN 1 CARD

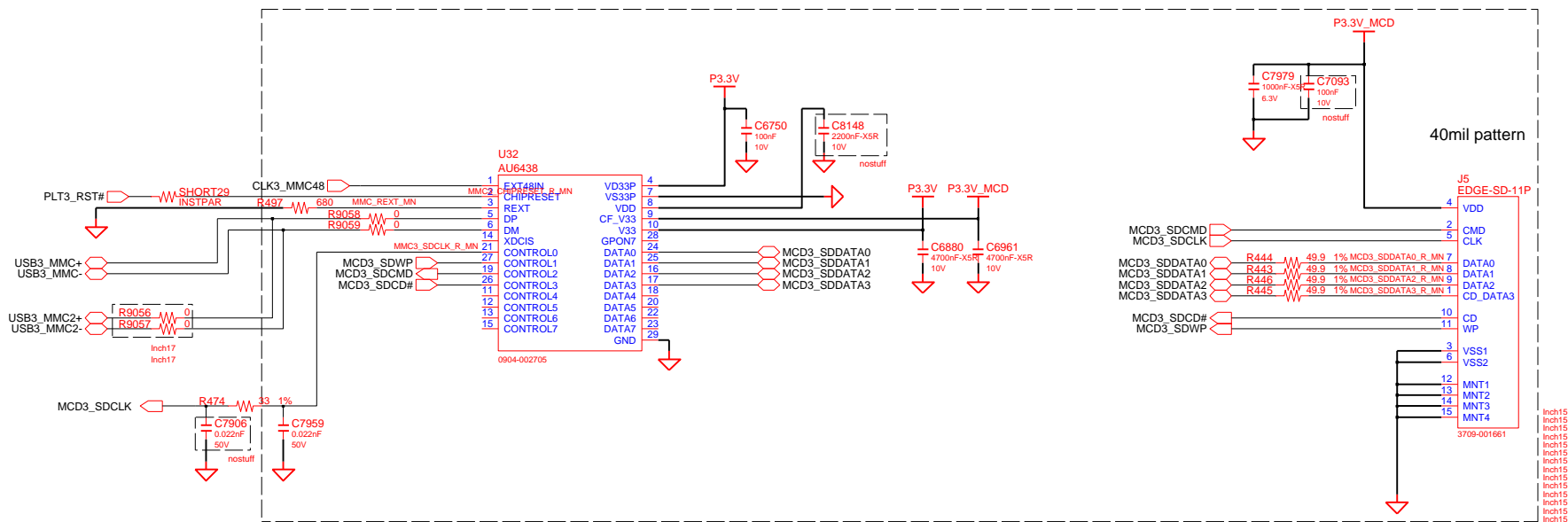

DESIGN	MS YANG	DATE	3/11/2011	TITLE	PETRONAS-15_QUAD MULTICARD 4 IN 1 CARD (AU6438)	SAMSUNG ELECTRONICS PART NO. BA41-01662A
CHECK	MK KIM	DEV. STEP	PR			
APPROVAL	BL LEE	REV	REV 1.0			
MODULE CODE		LAST EDIT	May 20, 2011 21:14:43 PM	PAGE 33 OF 51		

SAMSUNG PROPRIETARY

THIS DOCUMENT CONTAINS CONFIDENTIAL PROPRIETARY INFORMATION THAT IS SAMSUNG ELECTRONICS CO.'S PROPERTY. DO NOT DISCLOSE TO OR DUPLICATE FOR OTHERS EXCEPT AS AUTHORIZED BY SAMSUNG.

WLAN, 7mm

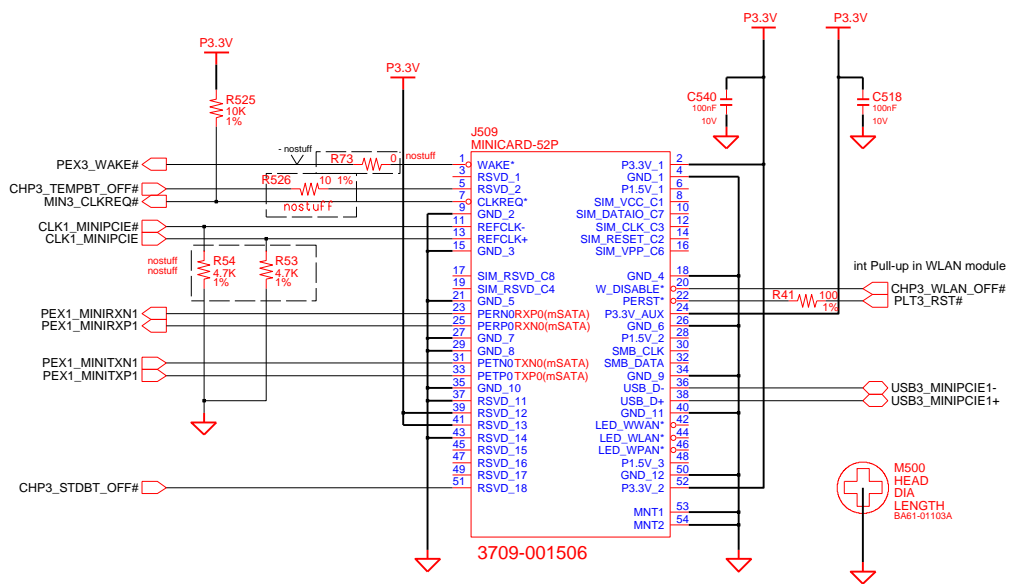

3709-001506

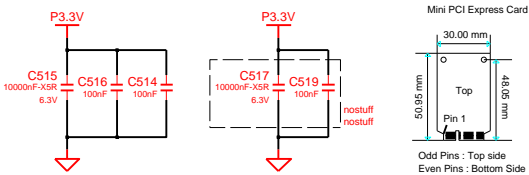

DESIGN	MS YANG	DATE	3/11/2011	TITLE	PETRONAS-15_QUAD	SAMSUNG ELECTRONICS
CHECK	MK KIM	DEV. STEP	PR	MINI_PCIE_CONN	PART NO.	
APPROVAL	BL LEE	REV	REV 1.0	WLAN	BA41-01662A	
MODULE CODE		LAST EDIT		May 20, 2011 21:14:43 PM	PAGE 34 OF 51	

SAMSUNG PROPRIETARY

THIS DOCUMENT CONTAINS CONFIDENTIAL PROPRIETARY INFORMATION THAT IS SAMSUNG ELECTRONICS CO.'S PROPERTY. DO NOT DISCLOSE TO OR DUPLICATE FOR OTHERS EXCEPT AS AUTHORIZED BY SAMSUNG.

SATA I/F CONN

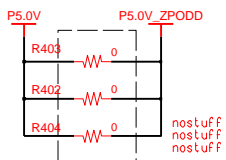
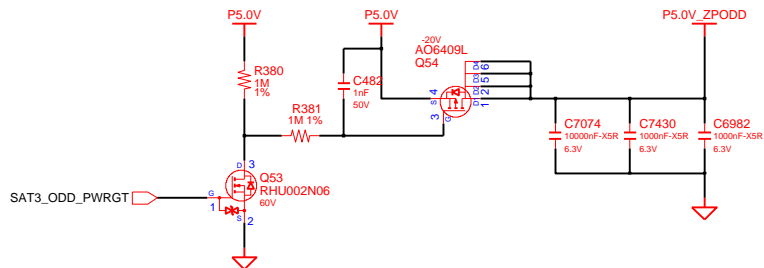

SATA HDD CONN

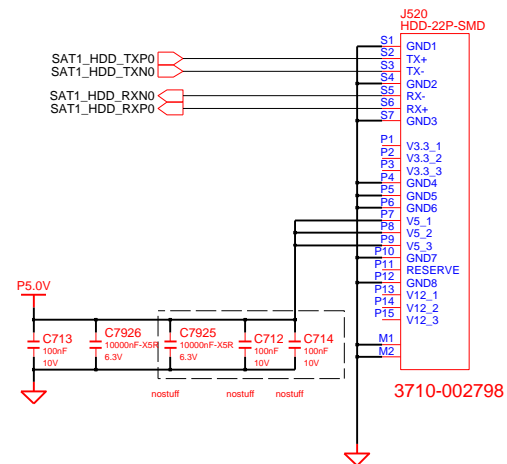

SATA 2'nd ODD CONN (17" only)

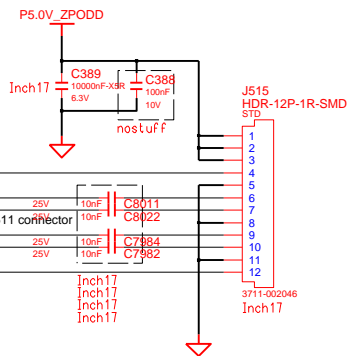

SATA 2'nd HDD CONN (17" only)

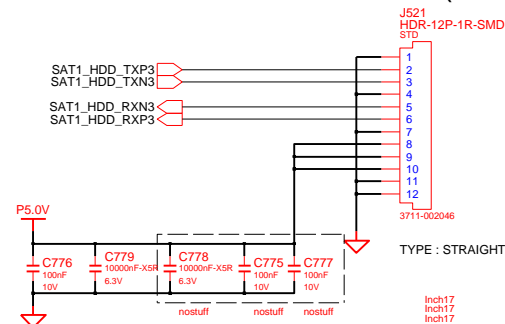

SATA ODD CONN (15" Only)

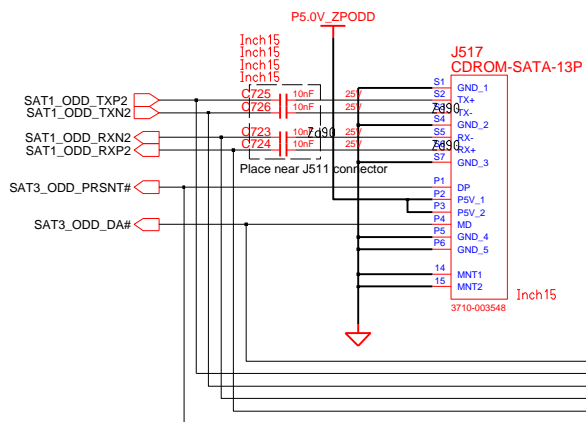

DESIGN	MS YANG	DATE	3/11/2011	TITLE	PETRONAS-15_QUAD	SAMSUNG ELECTRONICS PART NO: BA41-01662A
CHECK	MK KIM	DEV.STEP	PR	SATA DEVICES		
APPROVAL	BL LEE	REV	REV 1.0	SATA Interface		
MODULE CODE		LAST EDIT				
				May 20, 2011 21:14:43 PM	PAGE	35 OF 51

SAMSUNG PROPRIETARY

THIS DOCUMENT CONTAINS CONFIDENTIAL PROPRIETARY INFORMATION THAT IS SAMSUNG ELECTRONICS CO.'S PROPERTY. DO NOT DISCLOSE TO OR DUPLICATE FOR OTHERS EXCEPT AS AUTHORIZED BY SAMSUNG.

MAIN BOARD (MICOM)

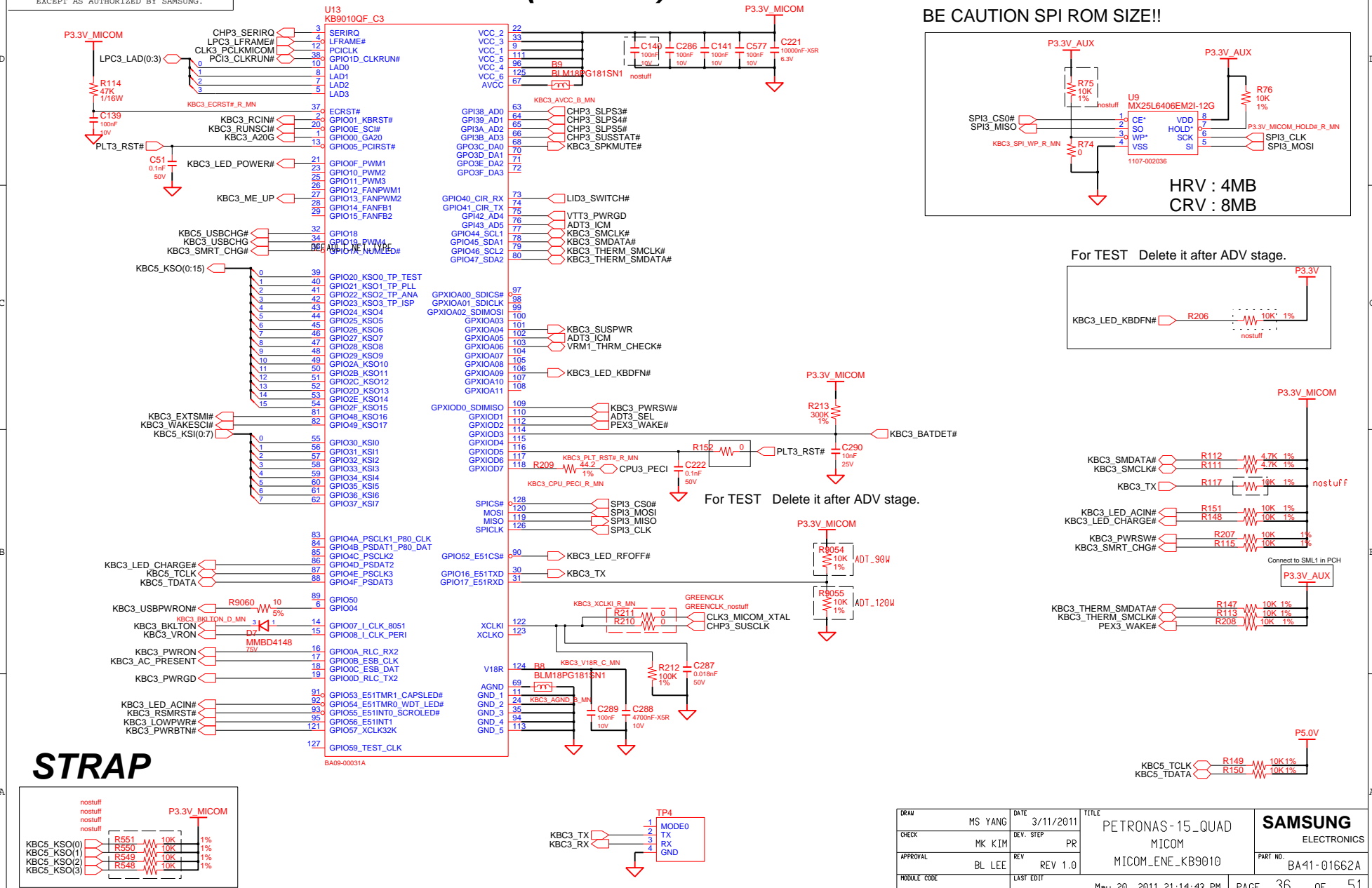

DRAW	MS YANG	DATE	3/11/2011	TITLE	PETRONAS-15_QUAD MICOM	SAMSUNG ELECTRONICS PART NO. BA41-01662A	
CHECK	MK KIM	DEV. STEP	PR	REV	1.0		
APPROVAL	BL LEE	REV	REV 1.0				
MODULE CODE		LAST EDIT					
May 20, 2011 21:14:43 PM						PAGE	36 OF 51

SAMSUNG PROPRIETARY

THIS DOCUMENT CONTAINS CONFIDENTIAL PROPRIETARY INFORMATION THAT IS SAMSUNG ELECTRONICS CO.'S PROPERTY. DO NOT DISCLOSE TO OR DUPLICATE FOR OTHERS EXCEPT AS AUTHORIZED BY SAMSUNG.

Micom Glue Logic

KEYBOARD

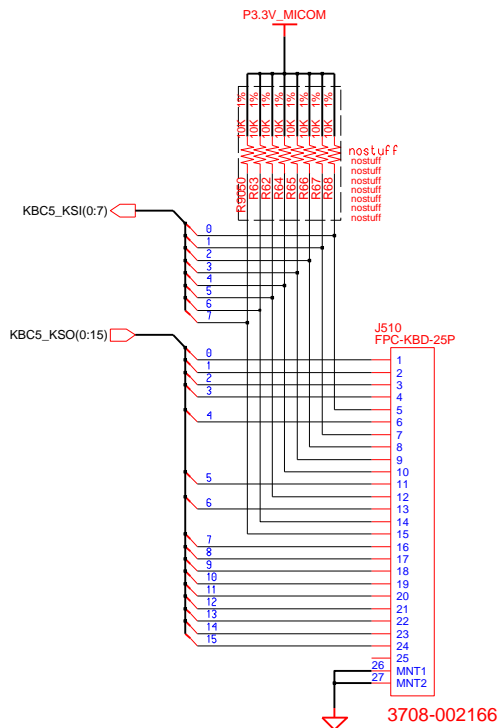

TOUCHPAD

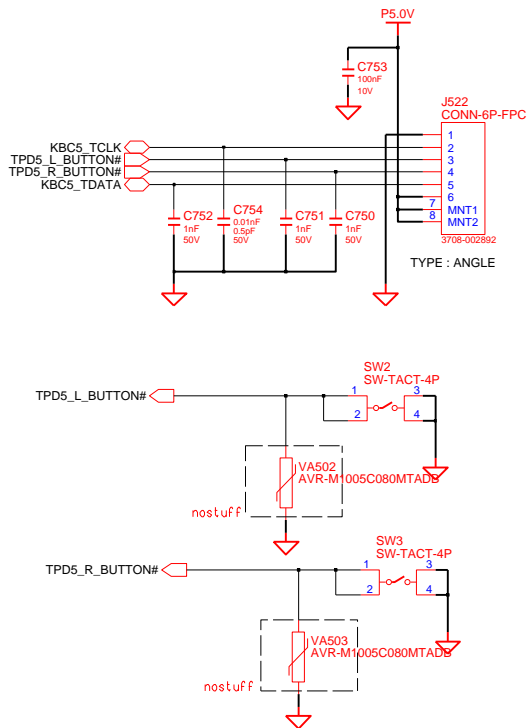

TOUCHPAD MAIN TO SUB

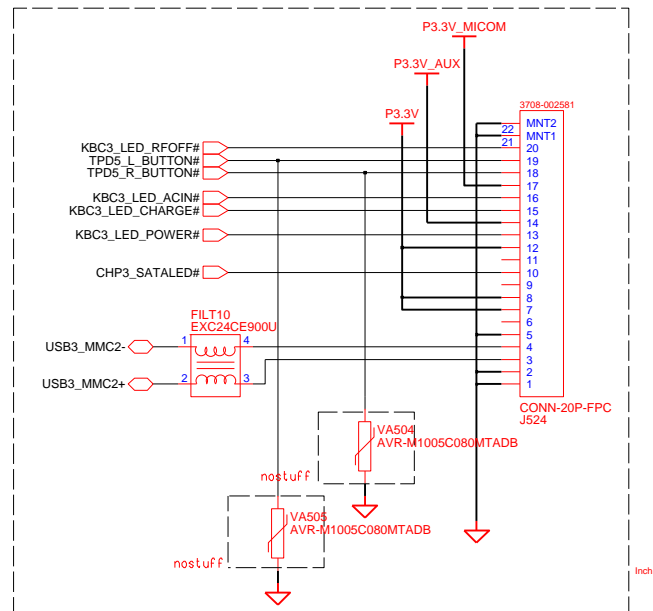

LID_SWITCH

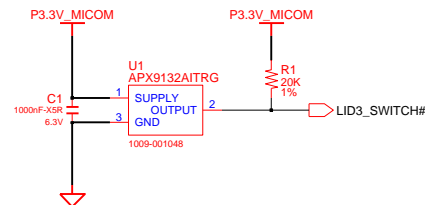

DESIGN	MS YANG	DATE	3/11/2011	TITLE	PETRONAS-15_QUAD	SAMSUNG ELECTRONICS PART NO. BA41-01662A
CHECK	MK KIM	DEV. STEP	PR		MICOM GLUE LOGIC	
APPROVAL	BL LEE	REV	REV 1.0		KEYBOARD & TOUCHPAD	
MODULE CODE		LAST EDIT				
				May 20, 2011 21:14:43 PM	PAGE 37	OF 51

SAMSUNG PROPRIETARY

THIS DOCUMENT CONTAINS CONFIDENTIAL
 PROPRIETARY INFORMATION THAT IS
 SAMSUNG ELECTRONICS CO.'S PROPERTY.
 DO NOT DISCLOSE TO OR DUPLICATE FOR OTHERS
 EXCEPT AS AUTHORIZED BY SAMSUNG.

LED for 15"

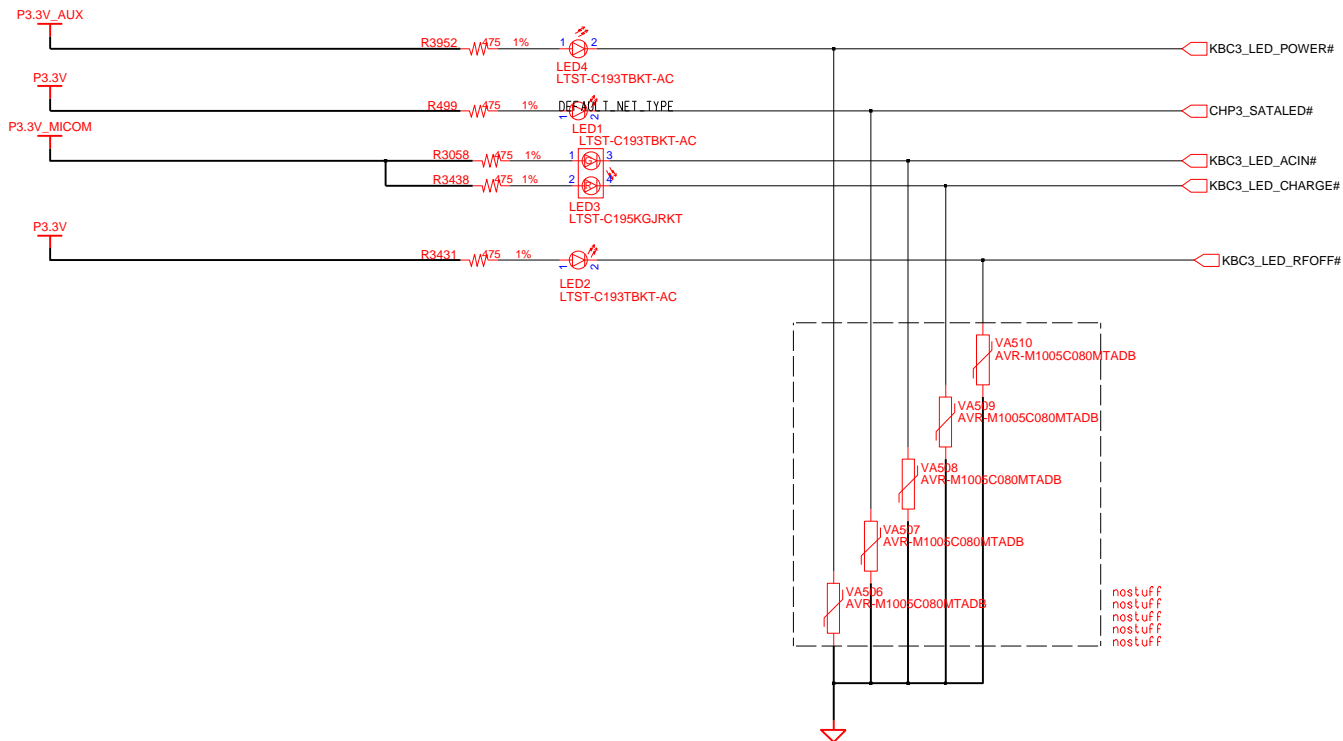

DRAW	MS YANG	DATE	3/11/2011	TITLE	PETRONAS-15_QUAD	SAMSUNG ELECTRONICS
CHECK	MK KIM	DEV. STEP	PR	LED_SWITCH	LED_SWITCH	
APPROVAL	BL LEE	REV	REV 1.0	LED_SWITCH		PART NO. BA41-01662A
MODULE CODE		LAST EDIT			May 20, 2011 21:14:43 PM	PAGE 38 OF 51

SAMSUNG PROPRIETARY

THIS DOCUMENT CONTAINS CONFIDENTIAL PROPRIETARY INFORMATION THAT IS SAMSUNG ELECTRONICS CO.'S PROPERTY. DO NOT DISCLOSE TO OR DUPLICATE FOR OTHERS EXCEPT AS AUTHORIZED BY SAMSUNG.

2 USB 2.0

MAIN TO SUB

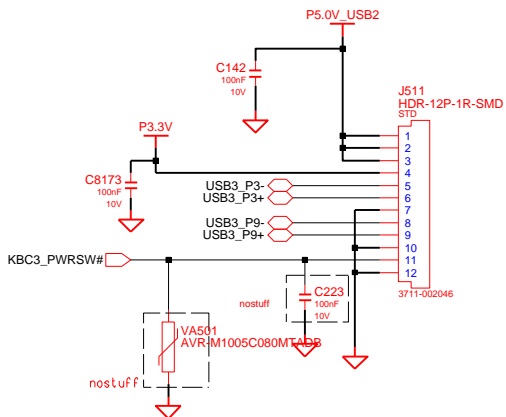

DESIGN	MS YANG	DATE	3/11/2011	TITLE	PETRONAS-15_QUAD	SAMSUNG ELECTRONICS
CHECK	MK KIM	DEV. STEP	PR	USB_CONN		
APPROVAL	BL LEE	REV	REV 1.0	USB Port	PART NO.	BA41-01662A
MODULE CODE		LAST EDIT	May 20, 2011 21:14:43 PM	PAGE	39	OF 51

SAMSUNG PROPRIETARY

THIS DOCUMENT CONTAINS CONFIDENTIAL PROPRIETARY INFORMATION THAT IS SAMSUNG ELECTRONICS CO.'S PROPERTY. DO NOT DISCLOSE TO OR DUPLICATE FOR OTHERS EXCEPT AS AUTHORIZED BY SAMSUNG.

2 USB PORT 3.0

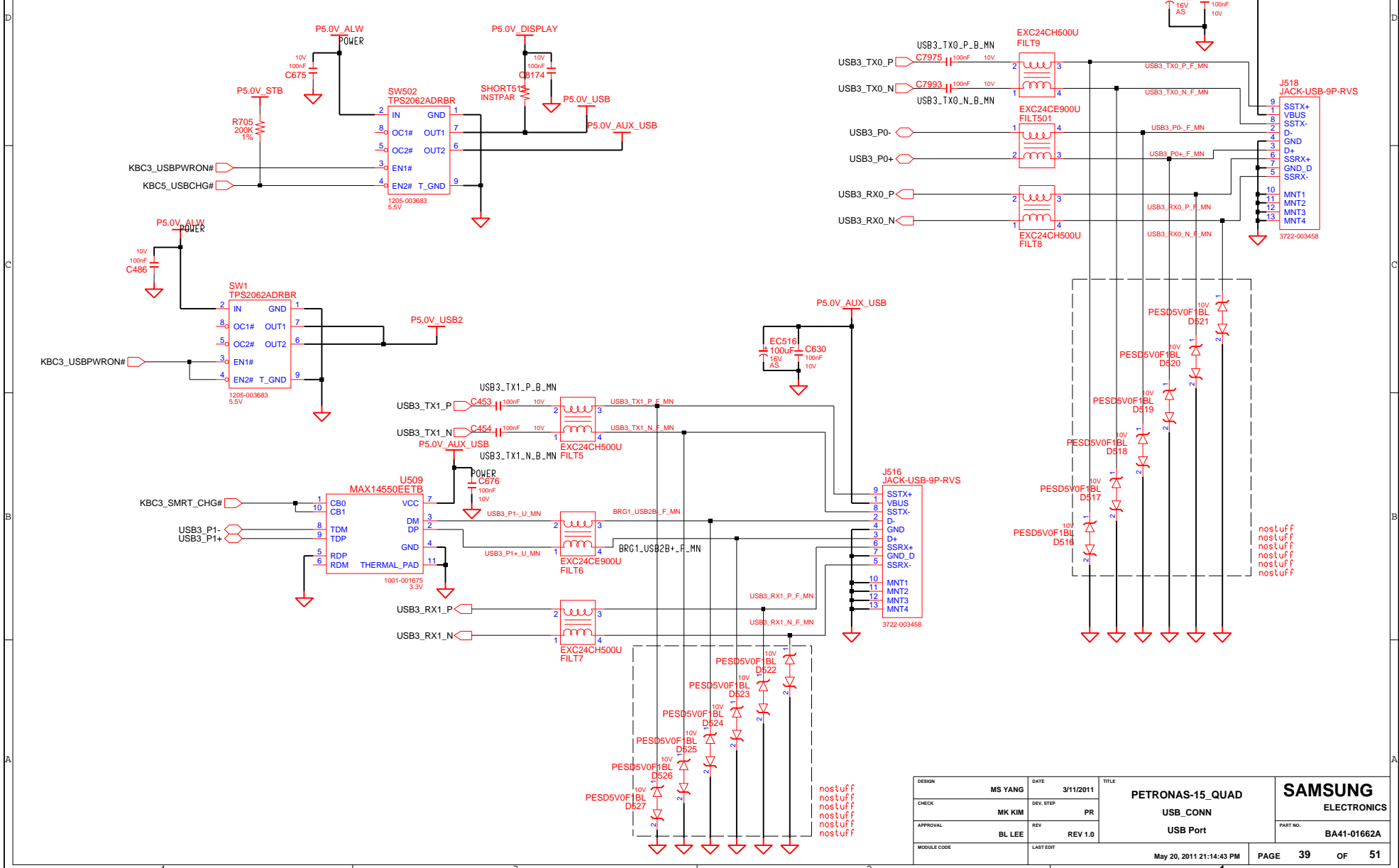

DESIGN	MS YANG	DATE	3/11/2011	TITLE	PETRONAS-15_QUAD	SAMSUNG ELECTRONICS
CHECK	MK KIM	DEV. STEP	PR	USB_CONN		
APPROVAL	BL LEE	REV	REV 1.0	USB Port		PART NO. BA41-01662A
MODULE CODE		LAST EDIT	May 20, 2011 21:14:43 PM	PAGE	39	OF 51

SAMSUNG PROPRIETARY
 THIS DOCUMENT CONTAINS CONFIDENTIAL
 PROPRIETARY INFORMATION THAT IS
 SAMSUNG ELECTRONICS CO.'S PROPERTY.
 DO NOT DISCLOSE TO OR DUPLICATE FOR OTHERS
 EXCEPT AS AUTHORIZED BY SAMSUNG.

CHARGER & POWER MANAGEMENT

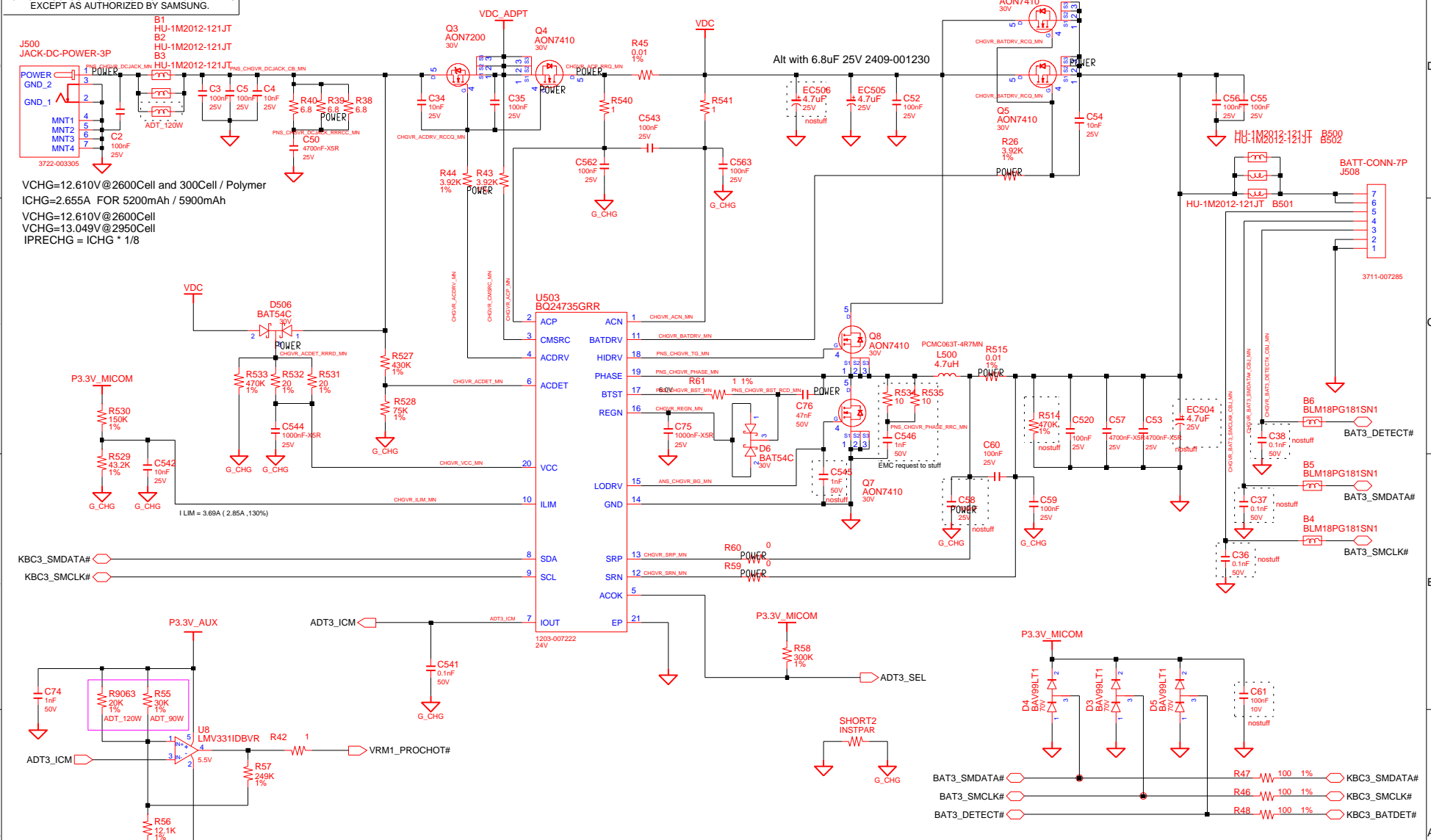

DRAW	MS YANG	DATE	3/11/2011	TITLE	PETRONAS-15_QUAD	SAMSUNG
CHECK	MK KIM	DEV. STEP	PR		CHARGER	ELECTRONICS
APPROVAL	BL LEE	REV	REV 1.0		TI BQ24735	PART NO.
MODULE CODE	undefined	LAST EDIT			May 20, 2011 21:14:43 PM	BA41-01662A
					PAGE	40 OF 51

SAMSUNG PROPRIETARY

THIS DOCUMENT CONTAINS CONFIDENTIAL PROPRIETARY INFORMATION THAT IS SAMSUNG ELECTRONICS CO.'S PROPERTY. DO NOT DISCLOSE TO OR DUPLICATE FOR OTHERS EXCEPT AS AUTHORIZED BY SAMSUNG.

P3.3V_AUX & P5.0V_ALW

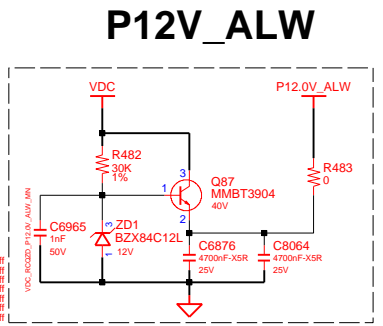
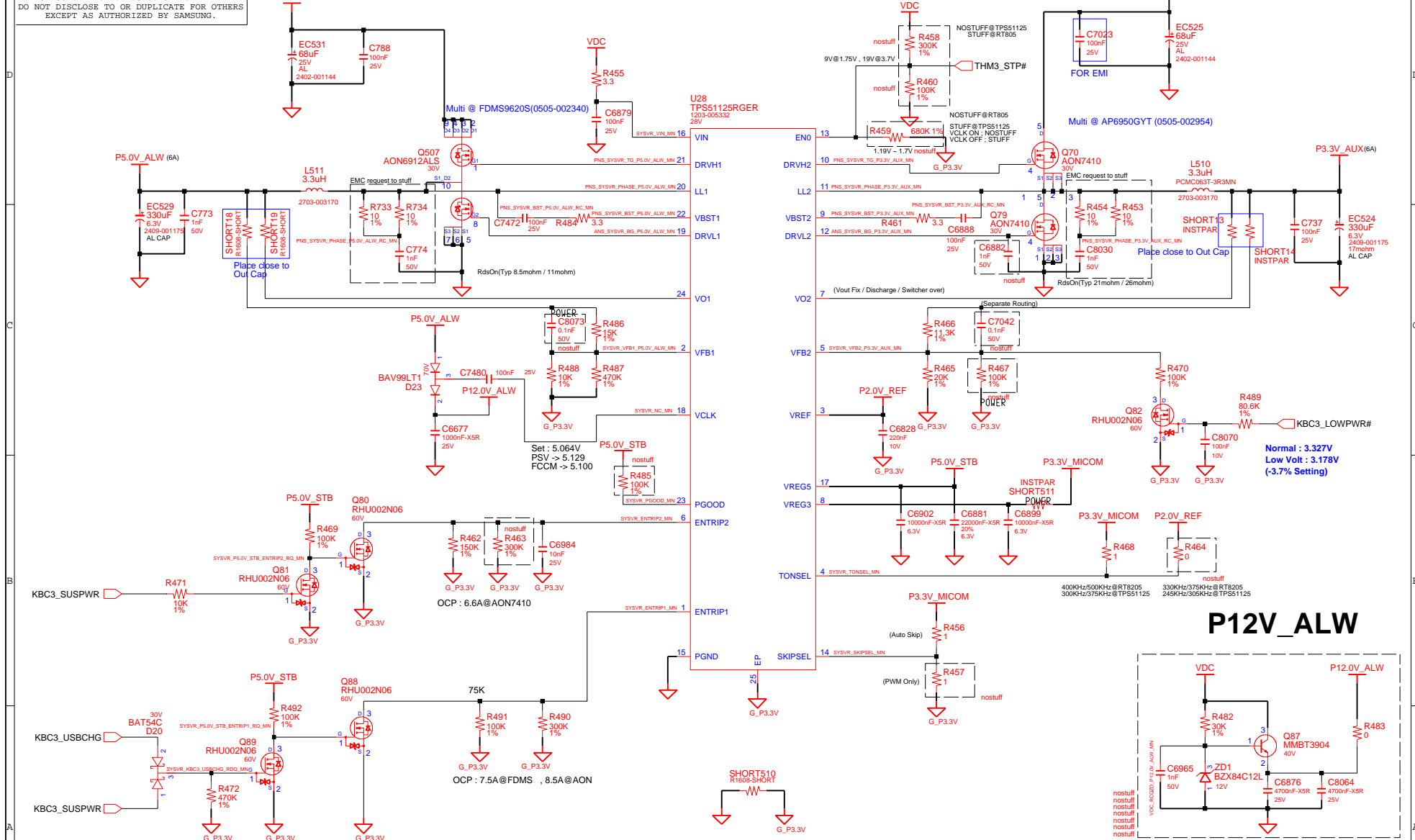

DESIGN	MS YANG	DATE	3/11/2011	TITLE	PETRONAS-15_QUAD	SAMSUNG ELECTRONICS PART NO. BA41-01662A
CHECK	MK KIM	DEV. STEP	PR		P3.3V_AUX / P5.0V_ALW	
APPROVAL	BL LEE	REV	REV 1.0		TI TPS51125	
MODULE CODE		LAST EDIT				
May 20, 2011 21:14:43 PM					PAGE 41 OF 51	

SAMSUNG PROPRIETARY

THIS DOCUMENT CONTAINS CONFIDENTIAL PROPRIETARY INFORMATION THAT IS SAMSUNG ELECTRONICS CO.'S PROPERTY. DO NOT DISCLOSE TO OR DUPLICATE FOR OTHERS EXCEPT AS AUTHORIZED BY SAMSUNG.

Chipset Power (P1.05V)

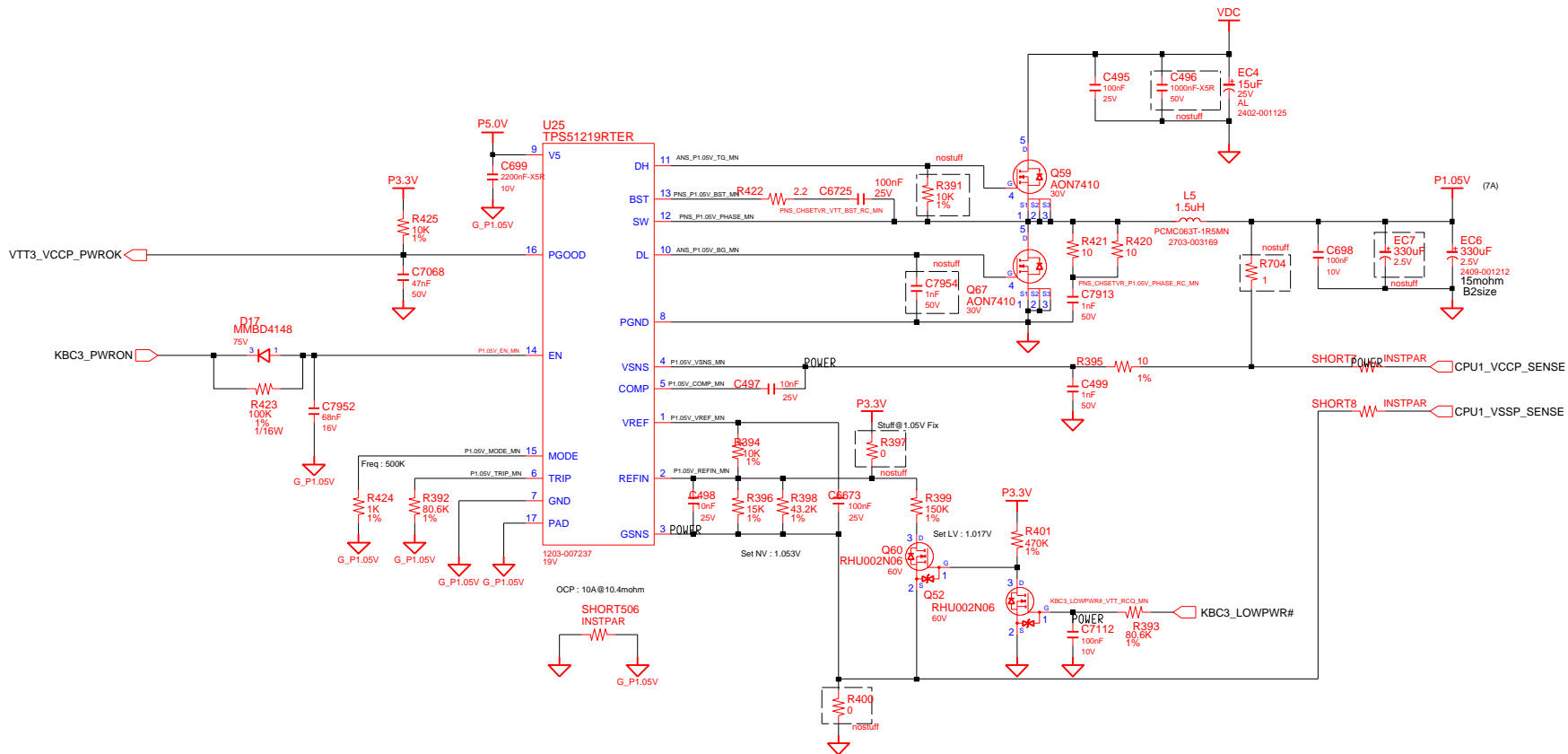

DRAW	MS YANG	DATE	3/11/2011	TITLE	PETRONAS-15_QUAD	SAMSUNG ELECTRONICS
CHECK	MK KIM	DEV. STEP	PR		P1.05V	
APPROVAL	BL LEE	REV	REV 1.0		TI TPSS51219	PART NO. BA41-01662A
MODULE CODE	undef ined	LAST EDIT	May 20, 2011 21:14:43 PM	PAGE	42	OF 51

SAMSUNG PROPRIETARY

THIS DOCUMENT CONTAINS CONFIDENTIAL PROPRIETARY INFORMATION THAT IS SAMSUNG ELECTRONICS CO.'S PROPERTY. DO NOT DISCLOSE TO OR DUPLICATE FOR OTHERS EXCEPT AS AUTHORIZED BY SAMSUNG.

CHIPSET POWER(VCCSA)

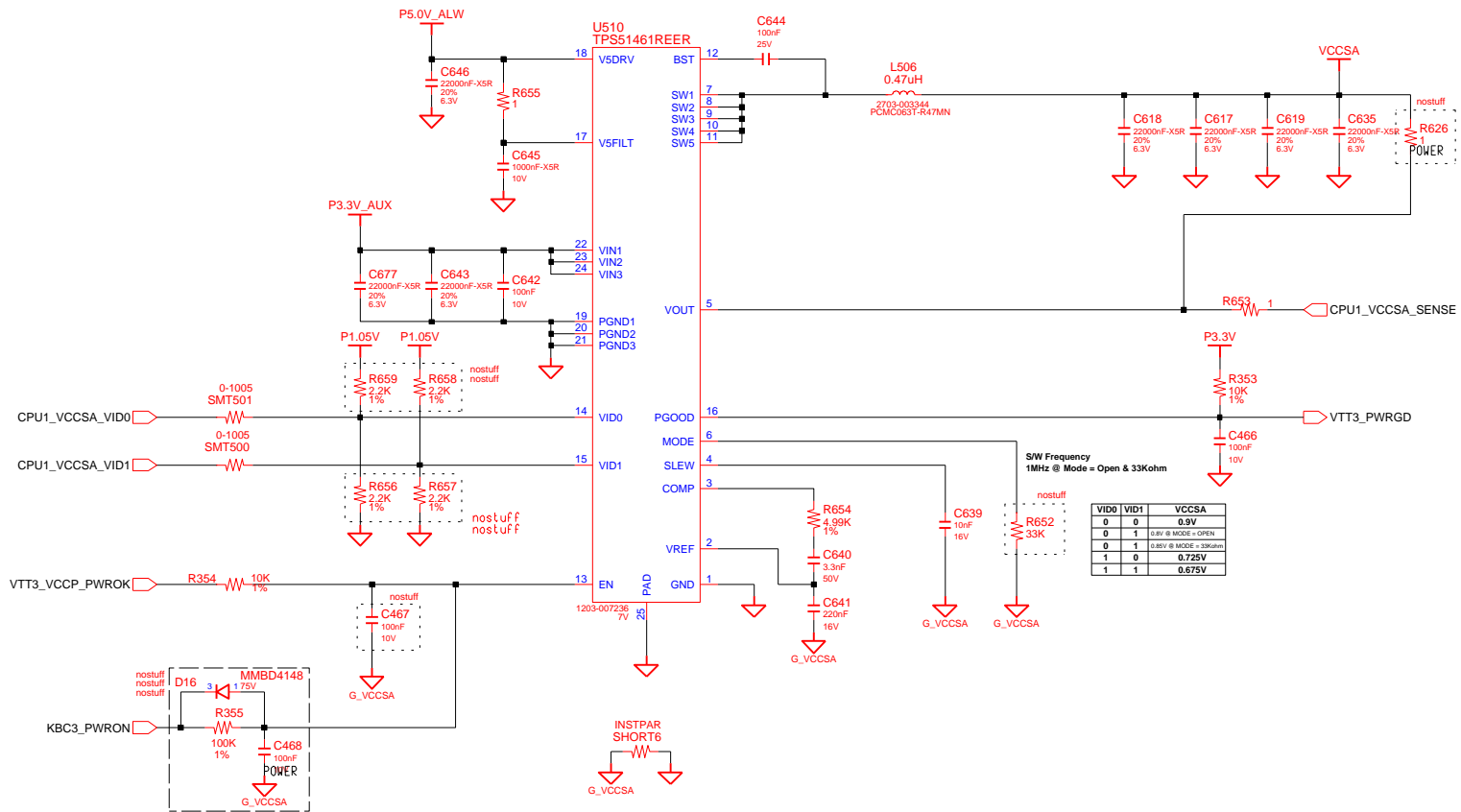

DESIGN	MS YANG	DATE	3/11/2011	TITLE	PETRONAS-15_QUAD P1.1V_VTT	SAMSUNG ELECTRONICS PART NO. BA41-01662A
CHECK	MK KIM	DEV. STEP	PR			
APPROVAL	BL LEE	REV	REV 1.0			
MODULE CODE		LAST EDIT				
					May 20, 2011 21:14:43 PM	PAGE 43 OF 51

SAMSUNG PROPRIETARY

THIS DOCUMENT CONTAINS CONFIDENTIAL PROPRIETARY INFORMATION THAT IS SAMSUNG ELECTRONICS CO.'S PROPERTY. DO NOT DISCLOSE TO OR DUPLICATE FOR OTHERS EXCEPT AS AUTHORIZED BY SAMSUNG.

Multi@FDM9620S(0505-002340)

DDR3 Power

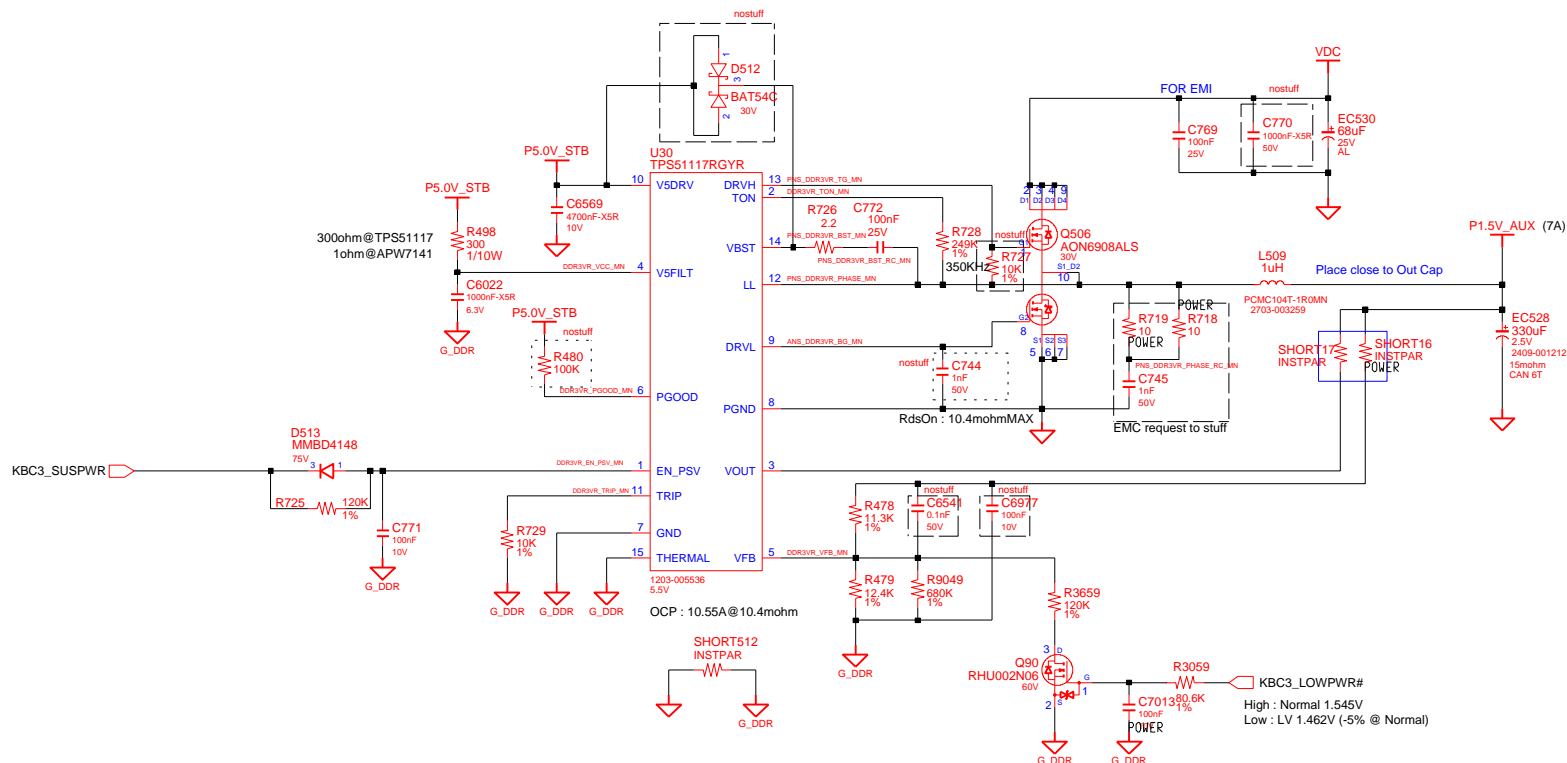

DDR3 VTT(0.75V)

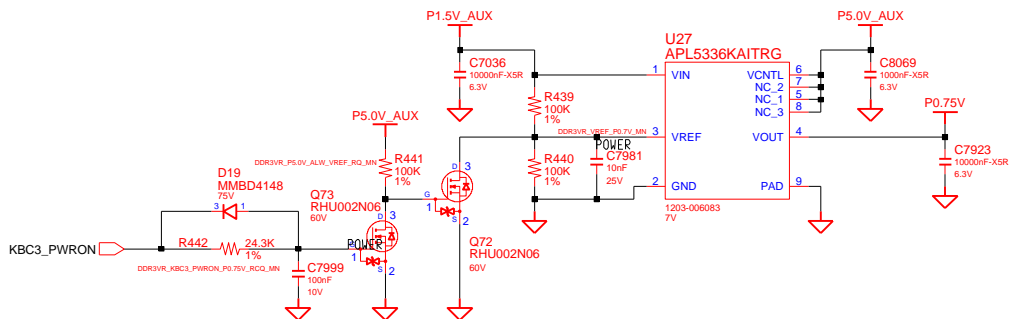

DRAW	MS YANG	DATE	3/11/2011	TITLE	PETRONAS-15_QUAD
CHECK	MK KIM	DEV. STEP	PR	PWR_MEMORY	SAMSUNG ELECTRONICS
APPROVAL	BL LEE	REV	REV 1.0	DDR3 POWER	
MODULE CODE	undefined	LAST EDIT	May 20, 2011 21:14:43 PM	PAGE	44 OF 51

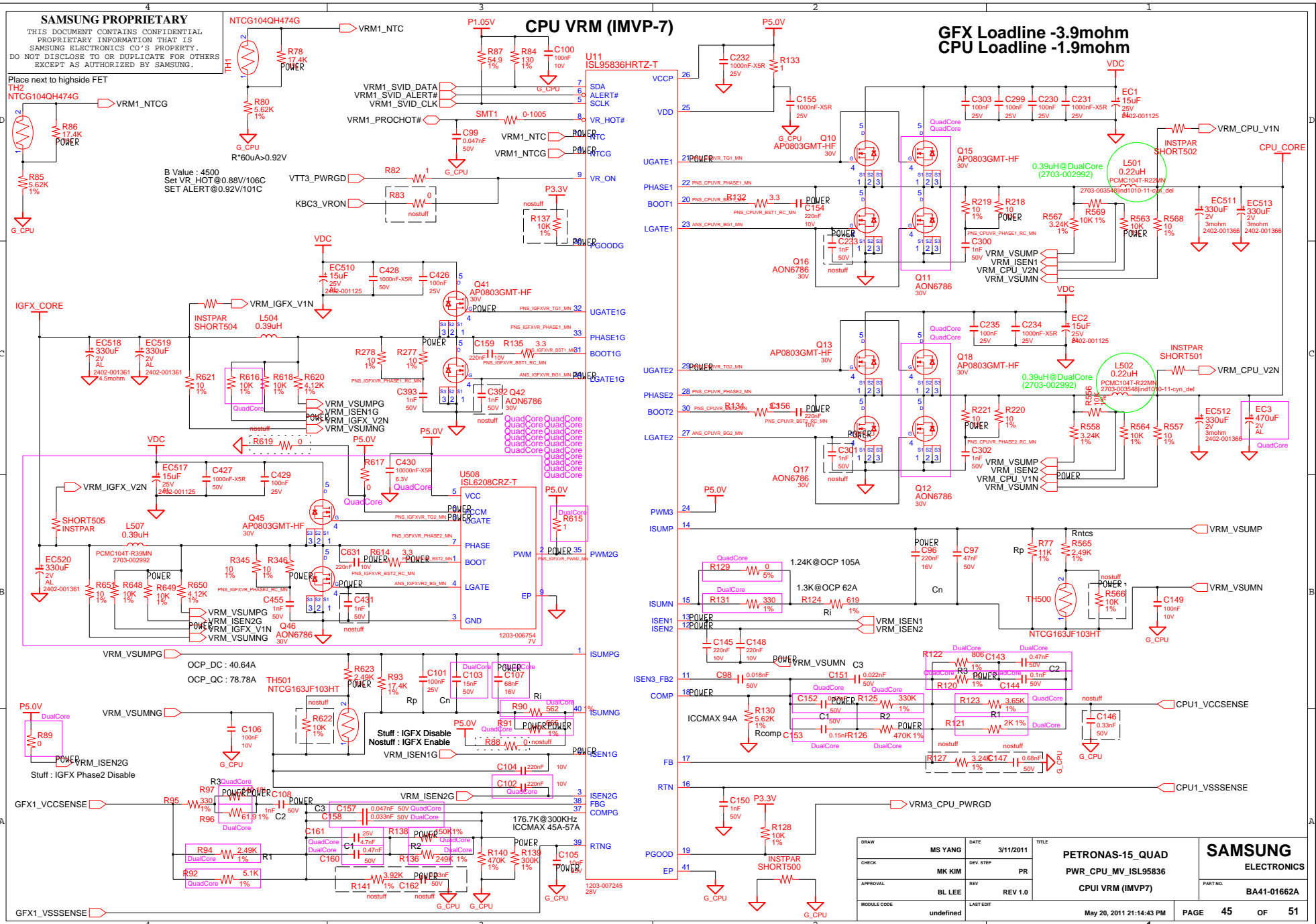

DRAW	MS YANG	DATE	3/11/2011	TITLE	PETRONAS-15_QUAD	SAMSUNG ELECTRONICS
CHECK	MK KIM	DEV. STEP	PR	PWR_CPU_MV_ISL95836	PART NO.	
APPROVAL	BL LEE	REV	REV 1.0	CPU1 VRM (IMVP7)	May 20, 2011 21:14:43 PM	PAGE 45 OF 51
MODULE CODE	undefined	LAST EDIT				

SAMSUNG PROPRIETARY

THIS DOCUMENT CONTAINS CONFIDENTIAL PROPRIETARY INFORMATION THAT IS SAMSUNG ELECTRONICS CO.'S PROPERTY. DO NOT DISCLOSE TO OR DUPLICATE FOR OTHERS EXCEPT AS AUTHORIZED BY SAMSUNG.

External Graphic Core Power

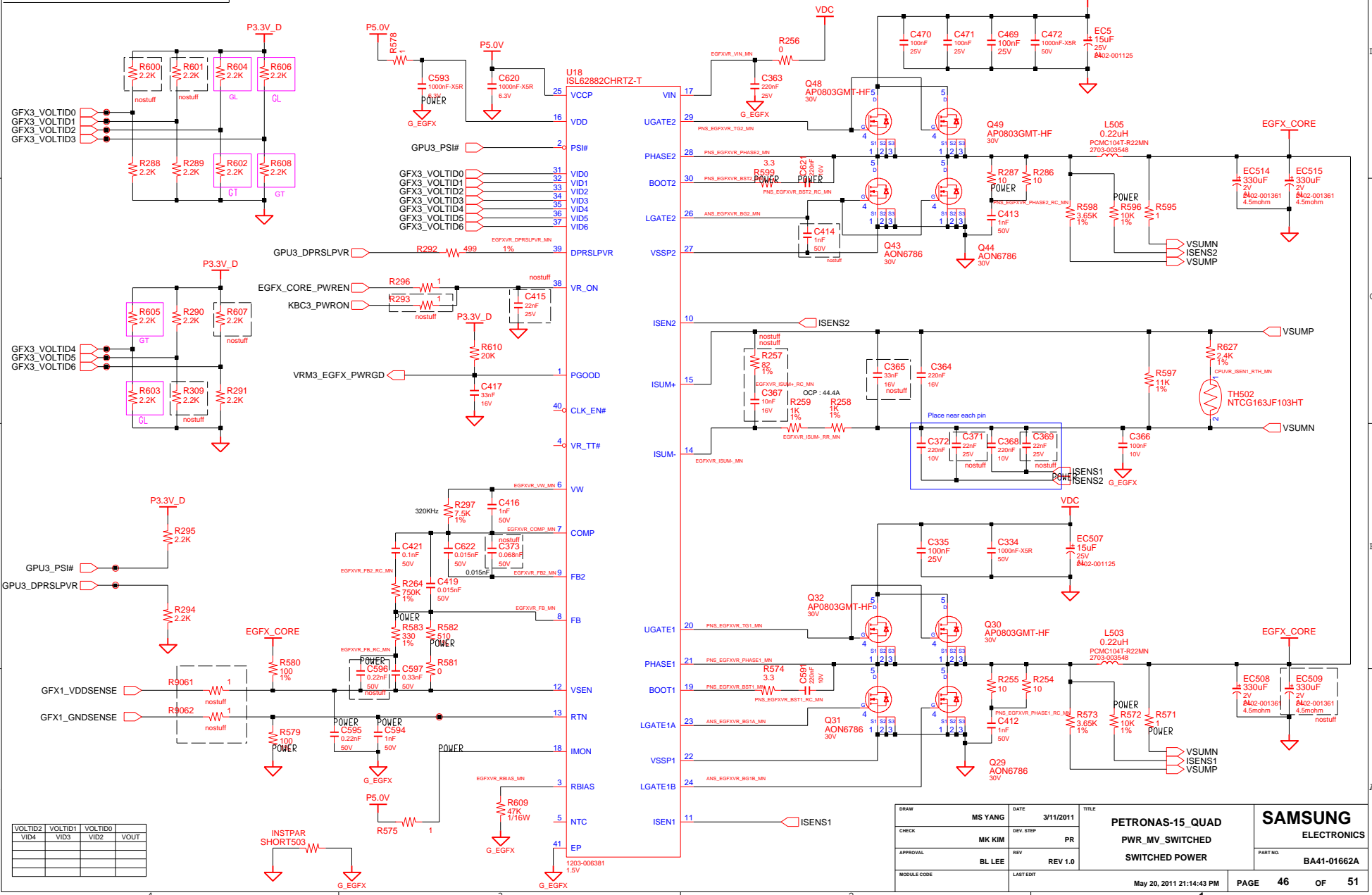

VOLTID2	VOLTID1	VOLTID0	VOUT
VID4	VID3	VID2	

DRAW	MS YANG	DATE	3/11/2011	TITLE	PETRONAS-15_QUAD
CHECK	MK KIM	DEV. STEP	PR		PWR_MV_SWITCHED
APPROVAL	BL LEE	REV	REV 1.0		SWITCHED POWER
MODULE CODE		LAST EDIT			
				May 20, 2011 21:14:43 PM	PAGE 46 OF 51

SAMSUNG ELECTRONICS
PART NO. BA41-01662A

SAMSUNG PROPRIETARY

THIS DOCUMENT CONTAINS CONFIDENTIAL PROPRIETARY INFORMATION THAT IS SAMSUNG ELECTRONICS CO.'S PROPERTY. DO NOT DISCLOSE TO OR DUPLICATE FOR OTHERS EXCEPT AS AUTHORIZED BY SAMSUNG.

Switched Power 1

(P5.0V -> P3.3V -> EGFX_CORE -> P1.8V -> P1.5V -> P0.75V -> P1.05V -> P0.85V_SA -> CPU_CORE)

P5.0V_AUX

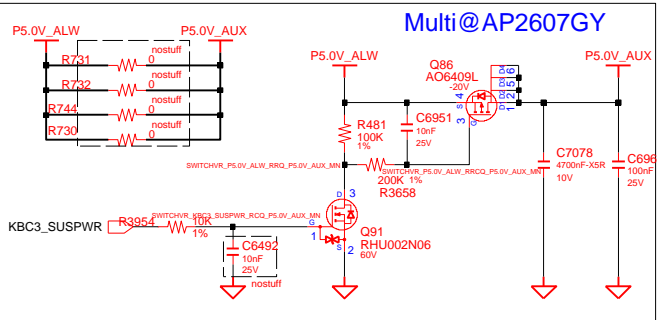

Switched Power On (P3.3V)

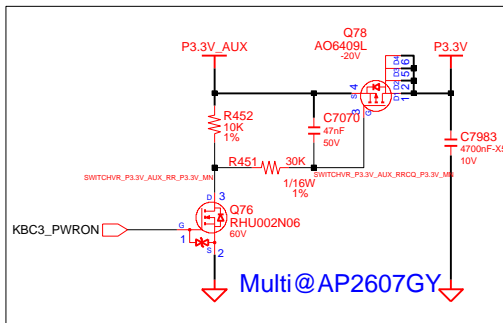

Switched Power On (P1.5V)

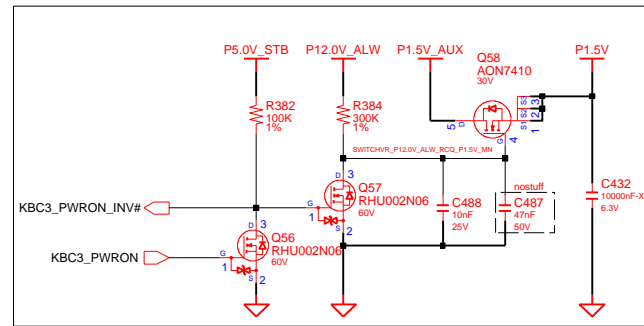

For nVIDIA GFX PWR Sequence
NVDD(EGFX_CORE) first and then FBVDDQ(gDDR3)

CHIPSET POWER(P1.8V)

Multi@G5173R41D(1203-006777)

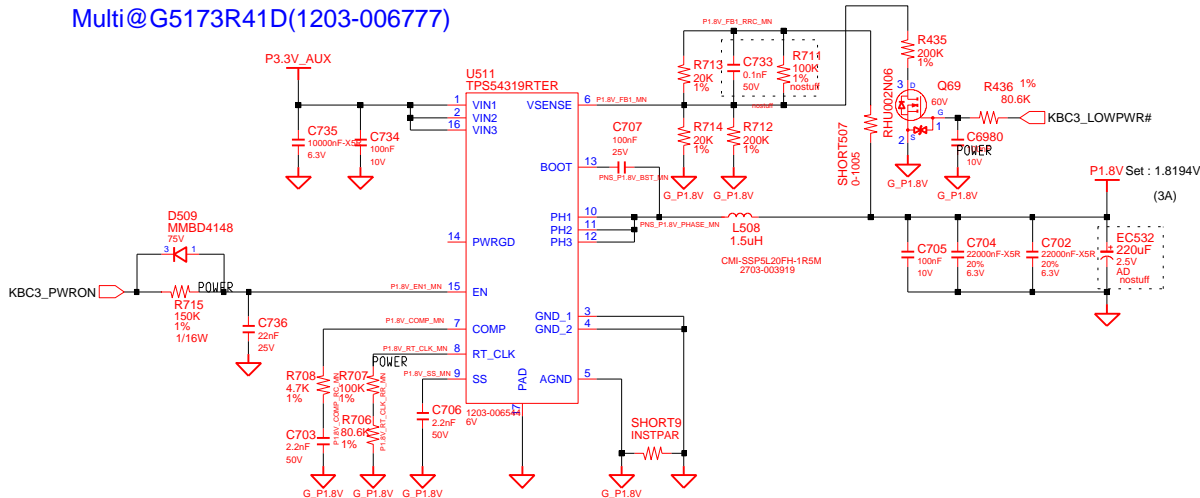

Switched Power On (P5.0V)

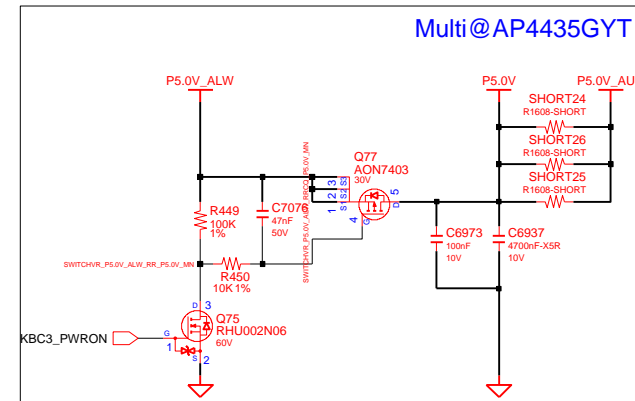

DRAW	MS YANG	DATE	3/11/2011	TITLE	PETRONAS-15_QUAD	SAMSUNG ELECTRONICS PART NO: BA41-01662A
CHECK	MK KIM	DEV. STEP	PR	PWR_MV_SWITCHED POWER		
APPROVAL	BL LEE	REV	REV 1.0	SWITCHED POWER		
MODULE CODE	undefined	LAST EDIT				
				May 20, 2011 21:14:43 PM	PAGE	47 OF 51

SAMSUNG PROPRIETARY

THIS DOCUMENT CONTAINS CONFIDENTIAL PROPRIETARY INFORMATION THAT IS SAMSUNG ELECTRONICS CO.'S PROPERTY. DO NOT DISCLOSE TO OR DUPLICATE FOR OTHERS EXCEPT AS AUTHORIZED BY SAMSUNG.

Discrete Switched Power (D3.3V : Max_1.2A)

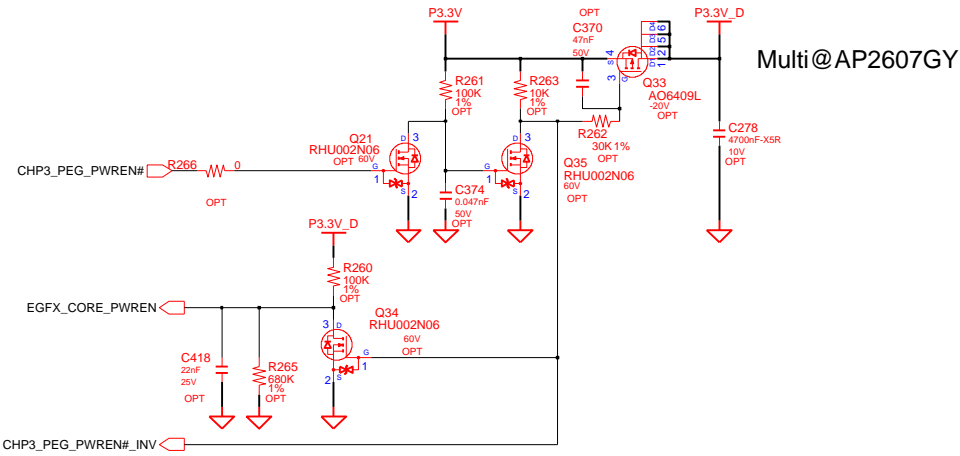

Discrete Switched Power (D1.5V : Max 5.0A)

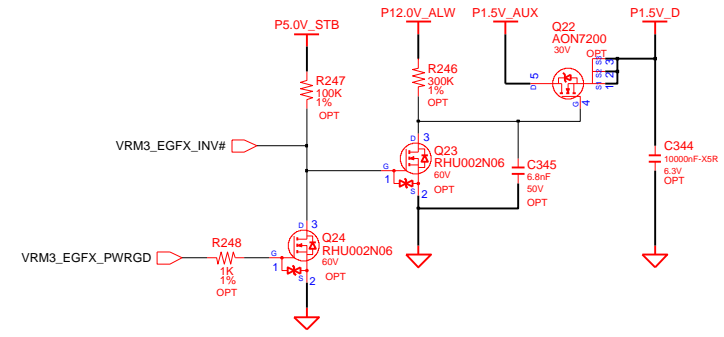

Discrete Switched Power (D1.05V : Max 3.6A)

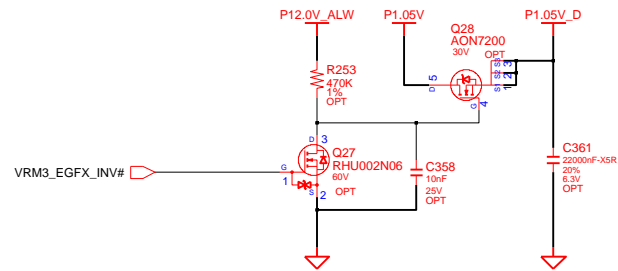

DRAW	MS YANG	DATE	3/11/2011	TITLE	PETRONAS-15_QUAD Switched PWR 2 FOR OPTIMUS PWR	SAMSUNG ELECTRONICS PART NO. BA41-01662A
CHECK	MK KIM	DEV.STEP	PR			
APPROVAL	BL LEE	REV	REV 1.0			
MODULE CODE		LAST EDIT				
				May 20, 2011 21:14:43 PM	PAGE	48 OF 51

SAMSUNG PROPRIETARY

THIS DOCUMENT CONTAINS CONFIDENTIAL PROPRIETARY INFORMATION THAT IS SAMSUNG ELECTRONICS CO.'S PROPERTY. DO NOT DISCLOSE TO OR DUPLICATE FOR OTHERS EXCEPT AS AUTHORIZED BY SAMSUNG.

iSSD POWER

Power P2.0V

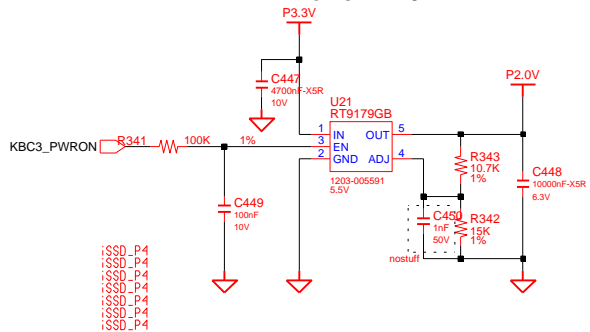

iSSD_P4
iSSD_P4
iSSD_P4
iSSD_P4
iSSD_P4
iSSD_P4
iSSD_P4
iSSD_P4

Power P1.0V_iSSD or P1.2V_iSSD

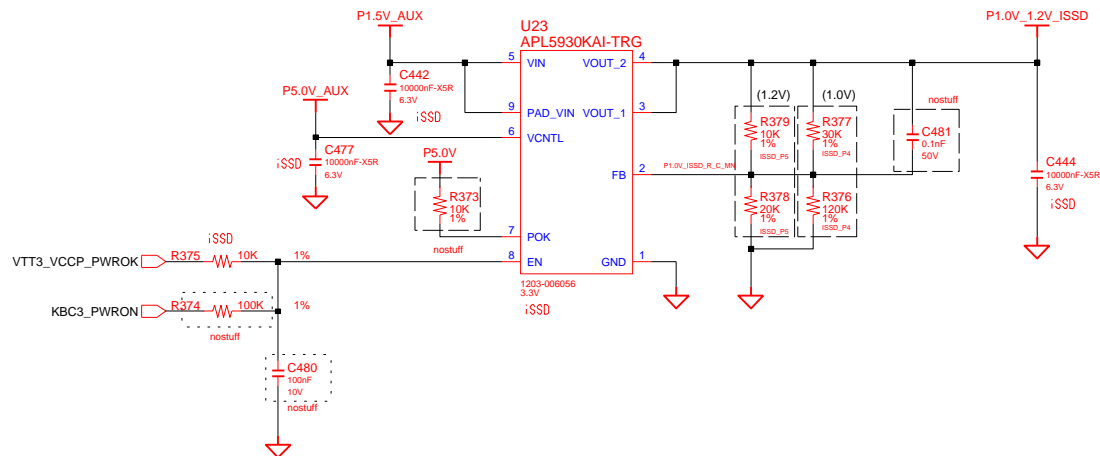

DESIGN	DATE	TITLE	SAMSUNG ELECTRONICS PART NO. BA41-undef i
CHECK	DEV. STEP	undef ined iSSD POWER	
APPROVAL	REV	undef ined iSSD POWER	
MODULE CODE	LAST EDIT	August , 9, 2011 8:05:39 PM	
		PAGE	58undef ined

SAMSUNG PROPRIETARY

THIS DOCUMENT CONTAINS CONFIDENTIAL PROPRIETARY INFORMATION THAT IS SAMSUNG ELECTRONICS CO.'S PROPERTY. DO NOT DISCLOSE TO OR DUPLICATE FOR OTHERS EXCEPT AS AUTHORIZED BY SAMSUNG.

POWER DISCHARGER

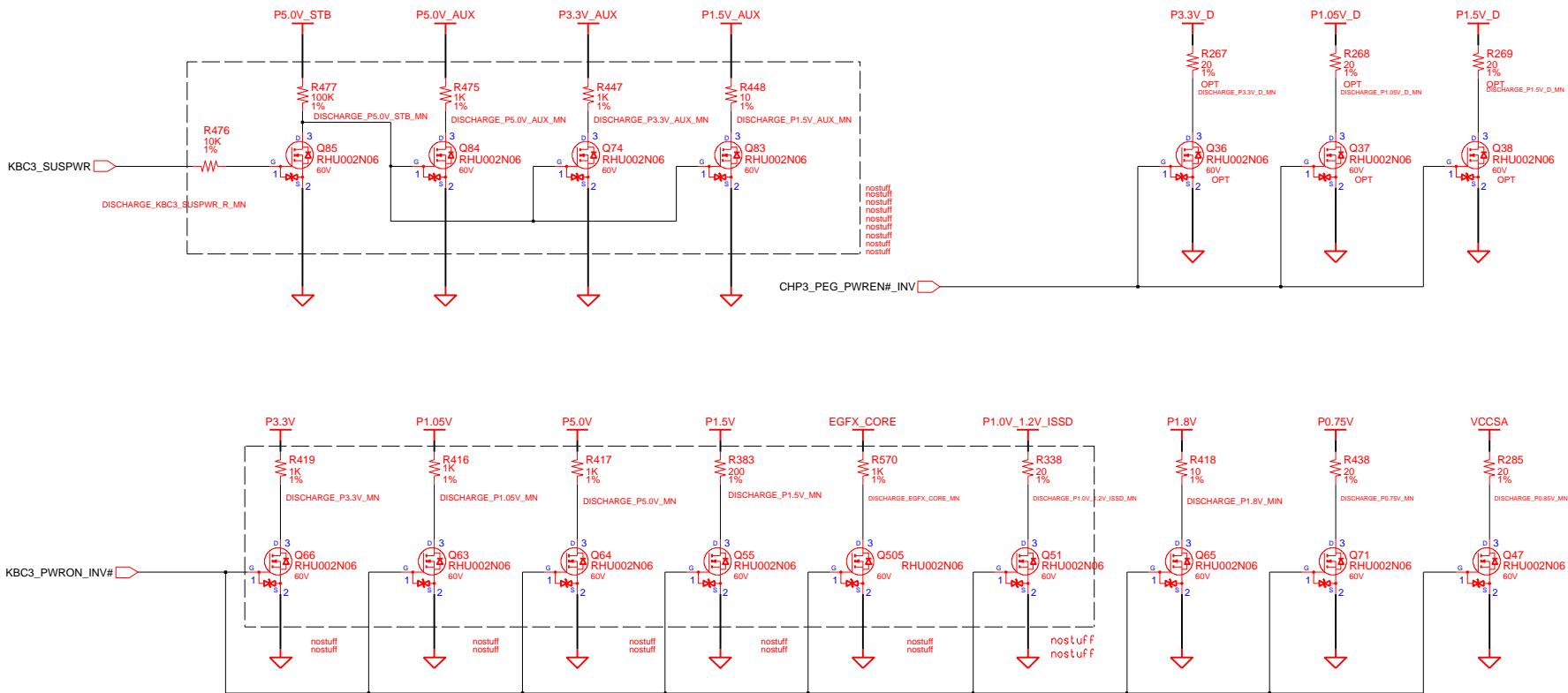

DESIGN	MS YANG	DATE	3/11/2011	TITLE	PETRONAS-15_QUAD POWER DISCHARGER POWER DISCHARGER	SAMSUNG ELECTRONICS PART NO. BA41-01662A
CHECK	MK KIM	DEV. STEP	PR			
APPROVAL	BL LEE	REV	REV 1.0			
MODULE CODE		LAST EDIT				
				May 20, 2011 21:14:43 PM	PAGE	49 OF 51

SAMSUNG PROPRIETARY

THIS DOCUMENT CONTAINS CONFIDENTIAL PROPRIETARY INFORMATION THAT IS SAMSUNG ELECTRONICS CO.'S PROPERTY. DO NOT DISCLOSE TO OR DUPLICATE FOR OTHERS EXCEPT AS AUTHORIZED BY SAMSUNG.

Mainboard Mount ((25-76)X1EA, (30-76)X7EA)

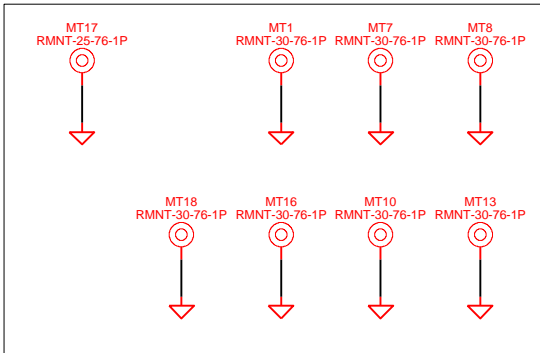

PCB FIX

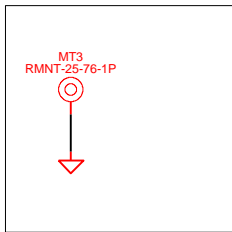

For bottom VDC line

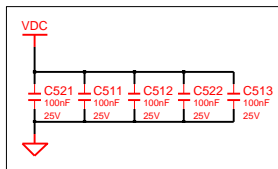

For 3rd layer VDC line

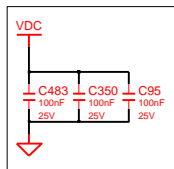

DESIGN	MS YANG	DATE	3/11/2011	TITLE	PETRONAS-15_QUAD	
CHECK	MK KIM	DEV. STEP	PR		MT Hole	
APPROVAL	BL LEE	REV	REV 1.0		MT Hole	PART NO.
MODULE CODE		LAST EDIT				BA41-01662A
				May 20, 2011 21:14:43 PM	PAGE	50 OF 51

SAMSUNG PROPRIETARY

THIS DOCUMENT CONTAINS CONFIDENTIAL PROPRIETARY INFORMATION THAT IS SAMSUNG ELECTRONICS CO.'S PROPERTY. DO NOT DISCLOSE TO OR DUPLICATE FOR OTHERS EXCEPT AS AUTHORIZED BY SAMSUNG.

USB SUB BOARD (15")

SUB TO MAIN

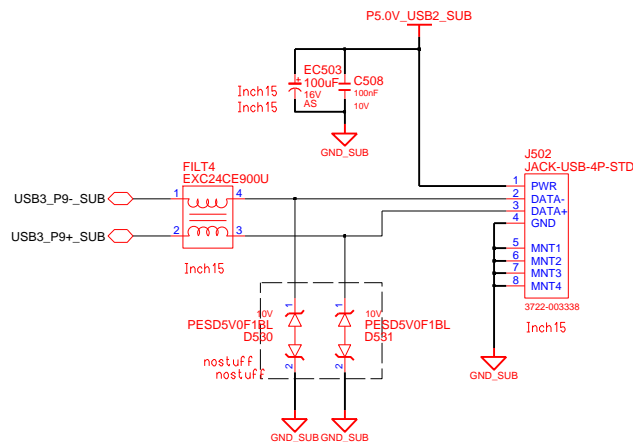
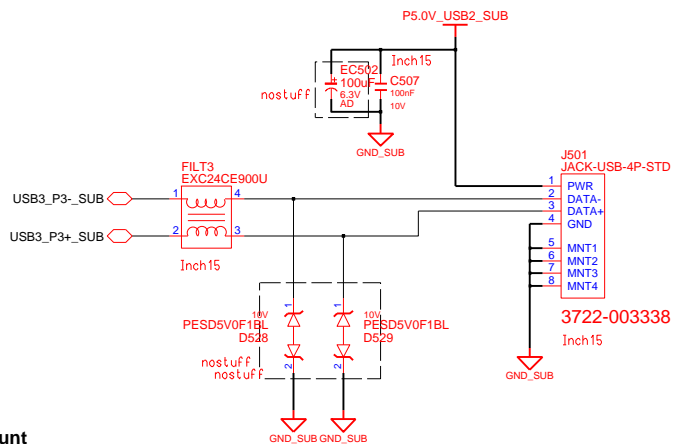
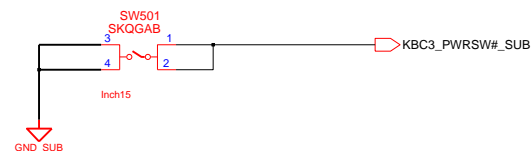
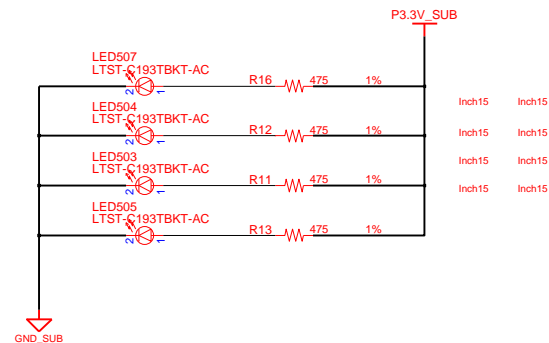
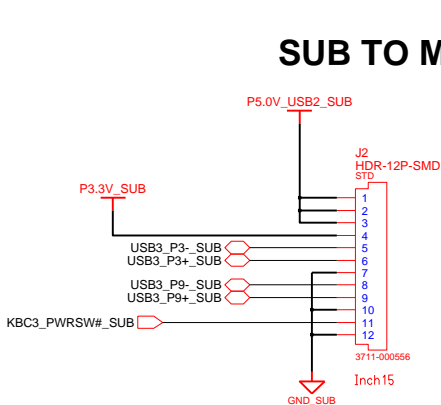

PCB Mount

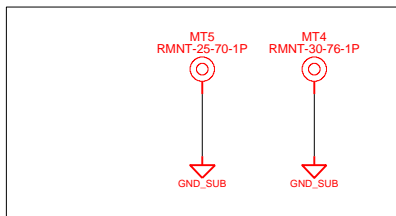

PLACE CLOSE TO USB SUB B'D Conenctor

PLACE CLOSE TO USB SUB B'D Conenctor

DESIGN	MS YANG	DATE	3/11/2011	TITLE	PETRONAS-15_QUAD SUB BOARD	SAMSUNG ELECTRONICS
CHECK	MK KIM	DEV. STEP	PR	15" USB Sub BOARD		
APPROVAL	BL LEE	REV	REV 1.0			PART NO. BA41-01662A
MODULE CODE	LAST EDIT		May 20, 2011 21:14:43 PM		PAGE	51 OF 51

SAMSUNG PROPRIETARY

THIS DOCUMENT CONTAINS CONFIDENTIAL PROPRIETARY INFORMATION THAT IS SAMSUNG ELECTRONICS CO.'S PROPERTY. DO NOT DISCLOSE TO OR DUPLICATE FOR OTHERS EXCEPT AS AUTHORIZED BY SAMSUNG.

USB SUB BOARD (17")

SUB TO MAIN

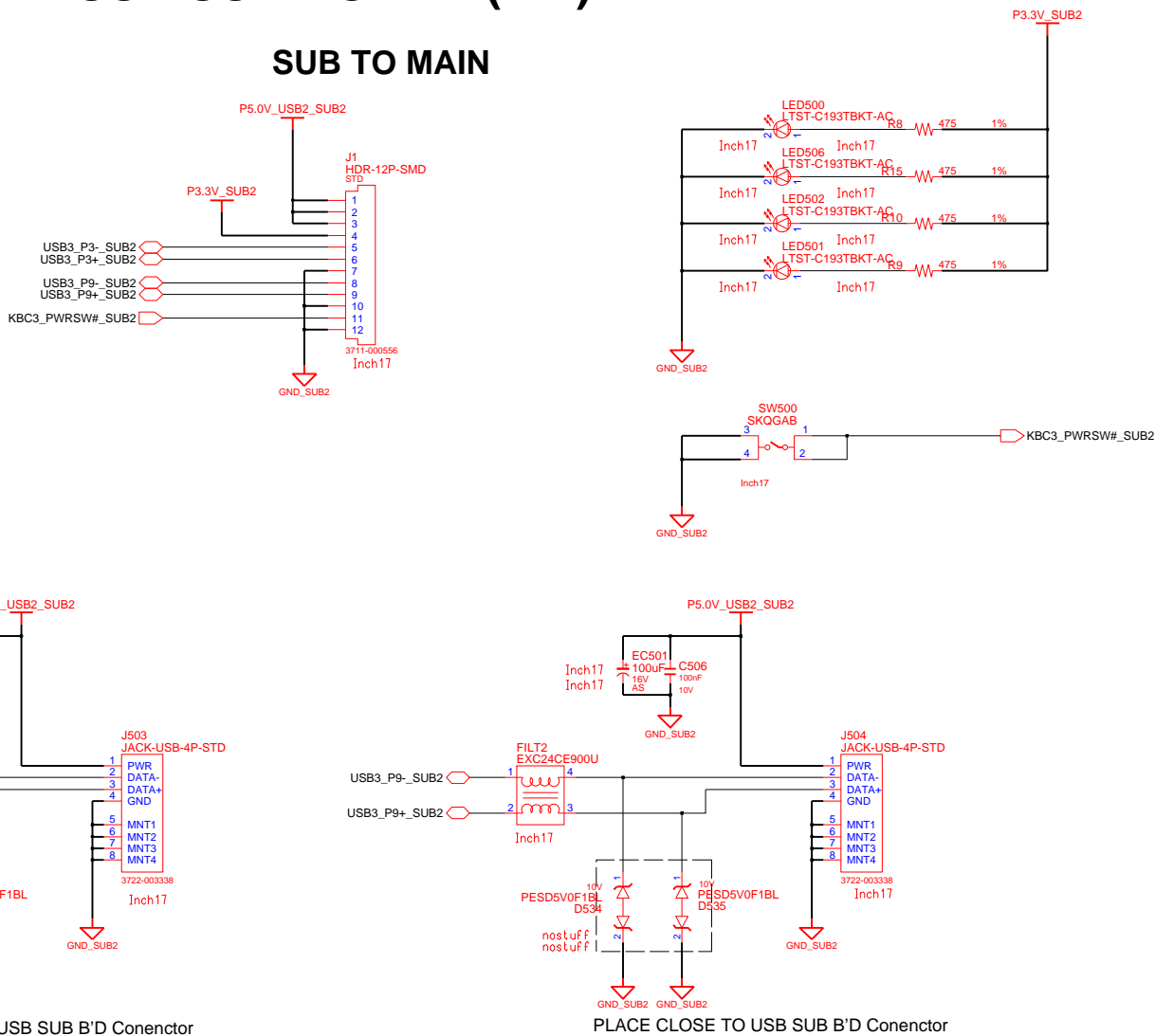

DESIGN	DATE	TITLE	SAMSUNG ELECTRONICS PART NO. BA41-undef i
CHECK	6/18/2011	undefined	
APPROVAL	DEV. STEP	SUB BOARD	
MODULE CODE	REV	17" USB SUB BOARD	
	UNDEFINED		PAGE 52 of 100
	UNDEFINED		
	LAST EDIT	June, 18, 2011 2:15:38 PM	