

GD1B Block Diagram

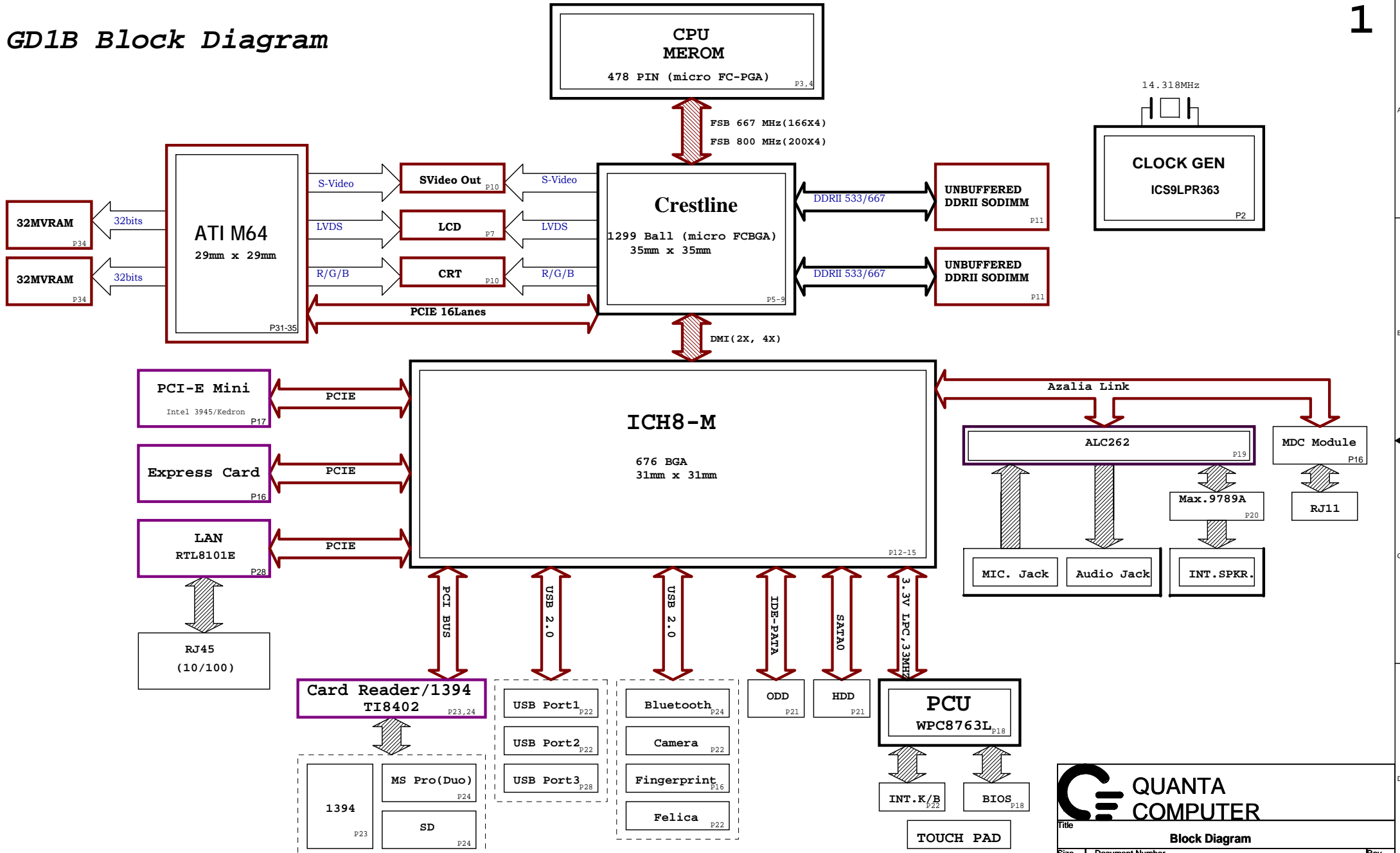

1. Level 1 Environment-related Substances Should NEVER be Used.
 2. Purchase ink, paint, wire rods, and Molding resins only from the business Partners that Sony approves as Green Partners.

QUANTA COMPUTER		
Title Block Diagram		
Size B	Document Number GD1B Main Board	Rev 2A
Date: Monday, August 20, 2007	Sheet 1 of 35	

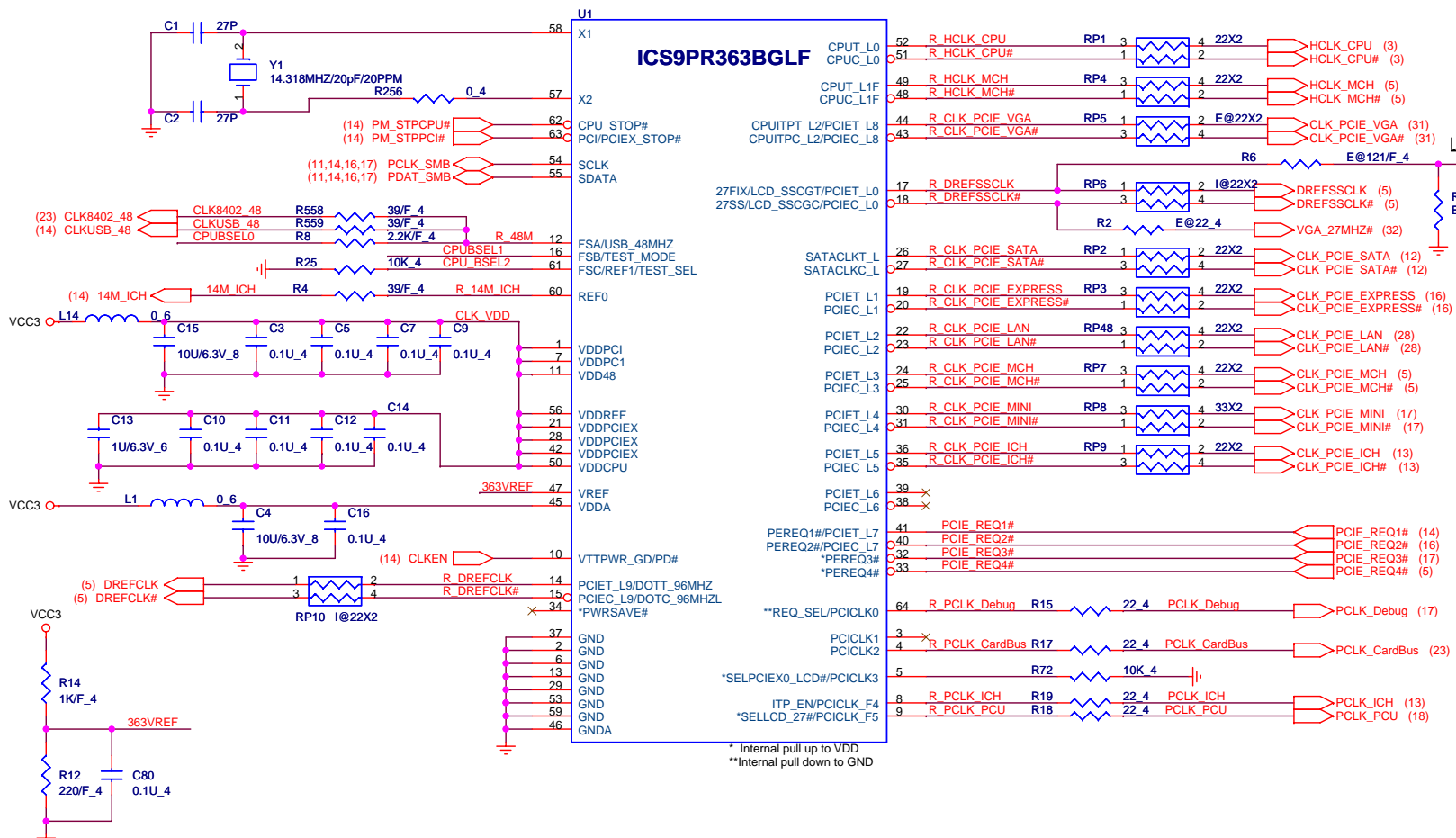

Signal		965GM	965PM
VGA_27MHZ	R6	NI	121
VGA_27MHZ#	R7	NI	71.5
CLK_PCIE_VGA	RP5	NI	22X2
DREFSSCLK	RP6	22X2	NI
DREFCLK	RP10	22X2	NI

PIN 5 R72	PIN 9 R24	PIN 14/15	PIN 17/18
LO (10K)	LO (10K) HI (NC)	PCIEX9 DOT96	27MHZ LCD
HI (NC)	LO (10K) HI (NC)	PCIEX9 DOT96	PCIEX0 PCIEX0

ITP_EN (PIN8)
 LOW : PIN43/44 SRC
 HIGH : PIN43,44 CPUTPT

PCIE_REQ1#	PCIE_L0	PCIE_L6	
PCIE_REQ2#	PCIE_L1	PCIE_L8	
PCIE_REQ3#	PCIE_L2	PCIE_L4	
PCIE_REQ4#	PCIE_L3	PCIE_L5	PCIE_L7

FSC BSEL2	FSB BSEL1	FSA BSEL0	CPU	SRC	PCI	REF	USB DOT	Spread %
0	0	0	266.66	100	33.33	14.318	48 96	0.5 Down
0	0	1	133.33	100	33.33	14.318	48 96	0.5 Down
* 0	1	0	200.00	100	33.33	14.318	48 96	0.5 Down
0	1	1	166.66	100	33.33	14.318	48 96	0.5 Down
1	0	0	333.33	100	33.33	14.318	48 96	0.5 Down
1	0	1	100.00	100	33.33	14.318	48 96	0.5 Down
1	1	0	400.00	100	33.33	14.318	48 96	0.5 Down
1	1	1	200.00	100	33.33	14.318	48 96	0.5 Down

1.Level 1 Environment-related Substances Should NEVER be Used.
 2.Purchase ink, paint, wire rods, and Molding resins only from the business Partners that Sony approves as Green Partners.



Title: **CLOCK GENERATOR**
 Size B Document Number: **GD1B Main Board** Rev 2A
 Date: Monday, August 20, 2007 Sheet 2 of 35

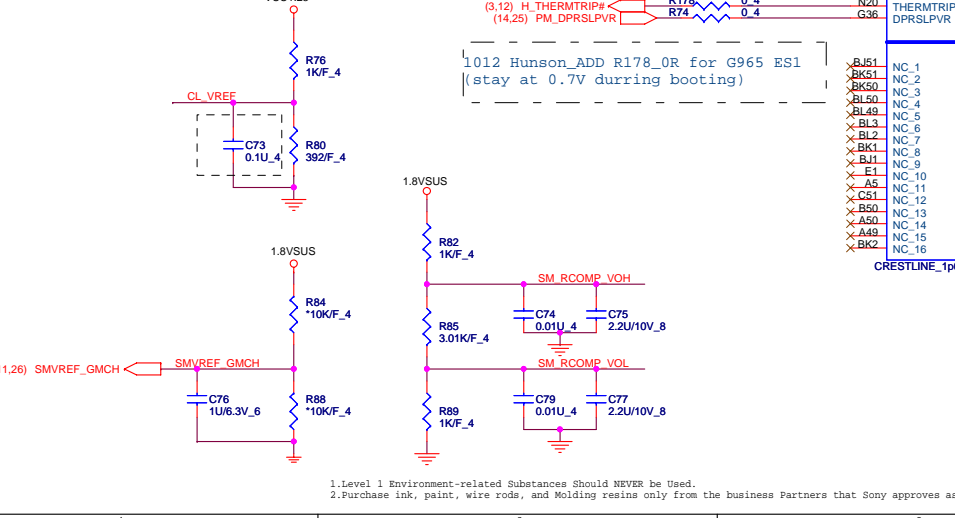
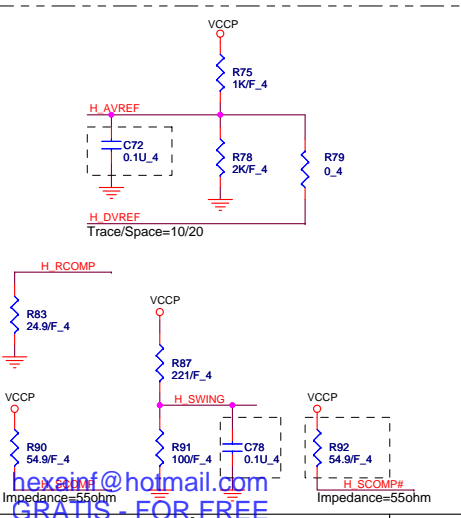
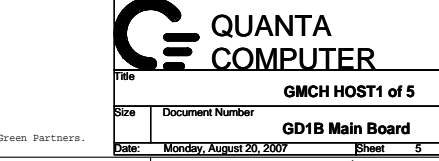
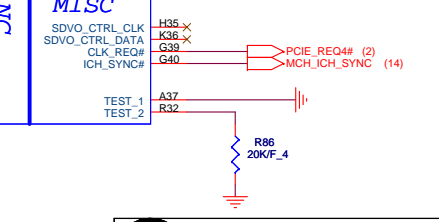
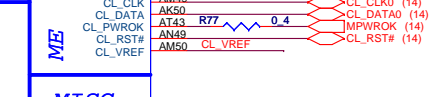
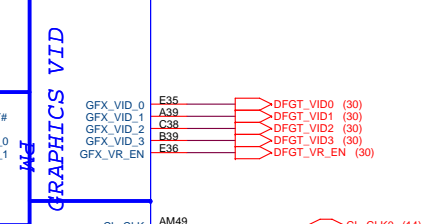
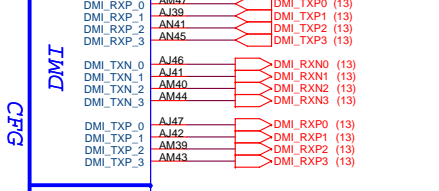
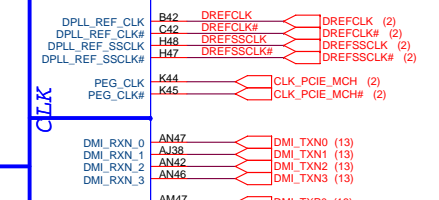
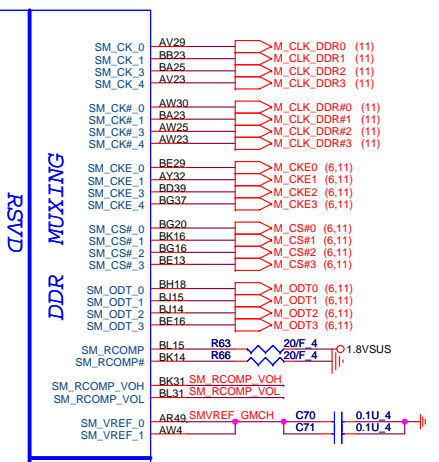
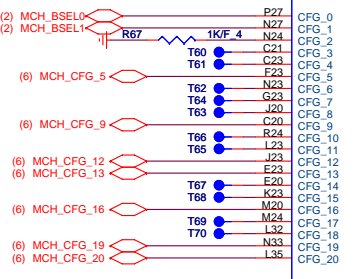
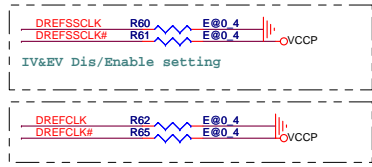
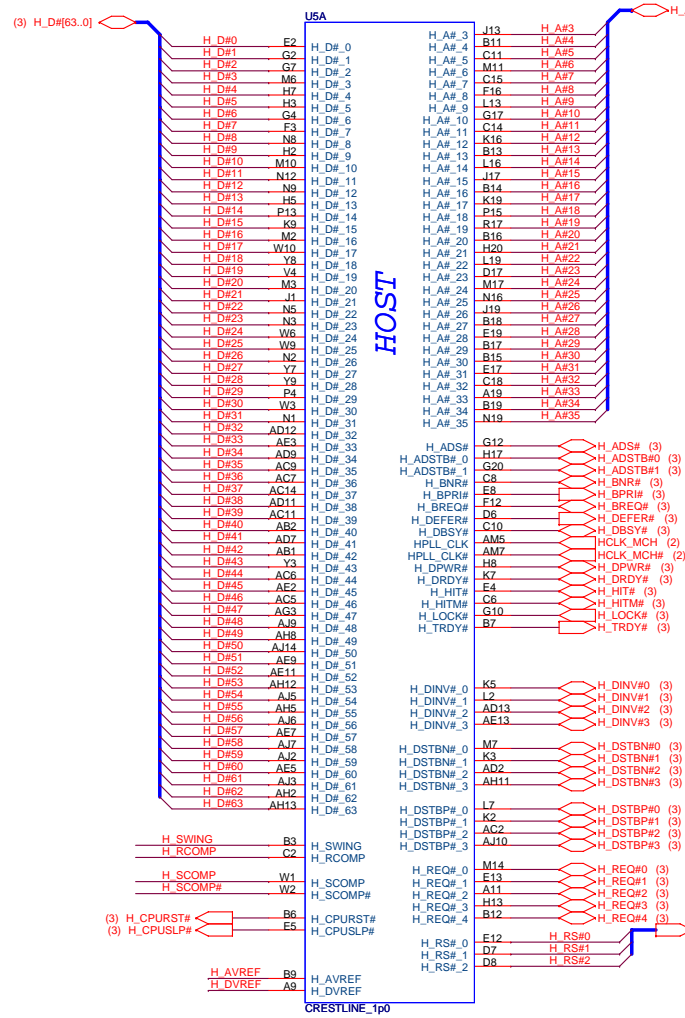

hex.sinf@hotmail.com
Impedance=55ohm
GRATIS - FOR FREE

1.Level 1 Environment-related Substances Should NEVER be Used.
2.Purchase ink, paint, wire rods, and Molding resins only from the business Partners that Sony approves as Green Partners.

QUANTA COMPUTER

Title: **GMCH HOST1 of 5**

Size: Document Number: **GD1B Main Board** Rev: **2A**

Date: **Monday, August 20, 2007** Sheet: **5** of **35**

VCCP (965GM 1.31A)
(965PM 1.57262A)

U5G

VCC CORE
VCC_1
VCC_2
VCC_3
VCC_4
VCC_5
VCC_6
VCC_7
VCC_8
VCC_9
VCC_10
VCC_11
VCC_12
VCC_13

POWER

VCC SM
VCC_SM_1
VCC_SM_2
VCC_SM_3
VCC_SM_4
VCC_SM_5
VCC_SM_6
VCC_SM_7
VCC_SM_8
VCC_SM_9
VCC_SM_10
VCC_SM_11
VCC_SM_12
VCC_SM_13
VCC_SM_14
VCC_SM_15
VCC_SM_16
VCC_SM_17
VCC_SM_18
VCC_SM_19
VCC_SM_20
VCC_SM_21
VCC_SM_22
VCC_SM_23
VCC_SM_24
VCC_SM_25
VCC_SM_26
VCC_SM_27
VCC_SM_28
VCC_SM_29
VCC_SM_30
VCC_SM_31
VCC_SM_32
VCC_SM_33
VCC_SM_34
VCC_SM_35
VCC_SM_36

VCC GFX
VCC_AGX_1
VCC_AGX_2
VCC_AGX_3
VCC_AGX_4
VCC_AGX_5
VCC_AGX_6
VCC_AGX_7
VCC_AGX_8
VCC_AGX_9
VCC_AGX_10
VCC_AGX_11
VCC_AGX_12
VCC_AGX_13
VCC_AGX_14
VCC_AGX_15
VCC_AGX_16
VCC_AGX_17
VCC_AGX_18
VCC_AGX_19
VCC_AGX_20
VCC_AGX_21
VCC_AGX_22
VCC_AGX_23
VCC_AGX_24
VCC_AGX_25
VCC_AGX_26
VCC_AGX_27
VCC_AGX_28
VCC_AGX_29
VCC_AGX_30
VCC_AGX_31
VCC_AGX_32
VCC_AGX_33
VCC_AGX_34

VCC GFX
VCC_AGX_1
VCC_AGX_2
VCC_AGX_3
VCC_AGX_4
VCC_AGX_5
VCC_AGX_6
VCC_AGX_7
VCC_AGX_8
VCC_AGX_9
VCC_AGX_10
VCC_AGX_11
VCC_AGX_12
VCC_AGX_13
VCC_AGX_14
VCC_AGX_15
VCC_AGX_16
VCC_AGX_17
VCC_AGX_18
VCC_AGX_19
VCC_AGX_20
VCC_AGX_21
VCC_AGX_22
VCC_AGX_23
VCC_AGX_24
VCC_AGX_25
VCC_AGX_26
VCC_AGX_27
VCC_AGX_28
VCC_AGX_29
VCC_AGX_30
VCC_AGX_31
VCC_AGX_32
VCC_AGX_33
VCC_AGX_34

VCC SM LIF
VCC_SM_LF1
VCC_SM_LF2
VCC_SM_LF3
VCC_SM_LF4
VCC_SM_LF5
VCC_SM_LF6
VCC_SM_LF7

CRESTLINE_1p0

VCC_AGX_NCTF_1
VCC_AGX_NCTF_2
VCC_AGX_NCTF_3
VCC_AGX_NCTF_4
VCC_AGX_NCTF_5
VCC_AGX_NCTF_6
VCC_AGX_NCTF_7
VCC_AGX_NCTF_8
VCC_AGX_NCTF_9
VCC_AGX_NCTF_10
VCC_AGX_NCTF_11
VCC_AGX_NCTF_12
VCC_AGX_NCTF_13
VCC_AGX_NCTF_14
VCC_AGX_NCTF_15
VCC_AGX_NCTF_16
VCC_AGX_NCTF_17
VCC_AGX_NCTF_18
VCC_AGX_NCTF_19
VCC_AGX_NCTF_20
VCC_AGX_NCTF_21
VCC_AGX_NCTF_22
VCC_AGX_NCTF_23
VCC_AGX_NCTF_24
VCC_AGX_NCTF_25
VCC_AGX_NCTF_26
VCC_AGX_NCTF_27
VCC_AGX_NCTF_28
VCC_AGX_NCTF_29
VCC_AGX_NCTF_30
VCC_AGX_NCTF_31
VCC_AGX_NCTF_32
VCC_AGX_NCTF_33
VCC_AGX_NCTF_34
VCC_AGX_NCTF_35
VCC_AGX_NCTF_36
VCC_AGX_NCTF_37
VCC_AGX_NCTF_38
VCC_AGX_NCTF_39
VCC_AGX_NCTF_40
VCC_AGX_NCTF_41
VCC_AGX_NCTF_42
VCC_AGX_NCTF_43
VCC_AGX_NCTF_44
VCC_AGX_NCTF_45
VCC_AGX_NCTF_46
VCC_AGX_NCTF_47
VCC_AGX_NCTF_48
VCC_AGX_NCTF_49
VCC_AGX_NCTF_50
VCC_AGX_NCTF_51
VCC_AGX_NCTF_52
VCC_AGX_NCTF_53
VCC_AGX_NCTF_54
VCC_AGX_NCTF_55
VCC_AGX_NCTF_56
VCC_AGX_NCTF_57
VCC_AGX_NCTF_58
VCC_AGX_NCTF_59
VCC_AGX_NCTF_60
VCC_AGX_NCTF_61
VCC_AGX_NCTF_62
VCC_AGX_NCTF_63
VCC_AGX_NCTF_64
VCC_AGX_NCTF_65
VCC_AGX_NCTF_66
VCC_AGX_NCTF_67
VCC_AGX_NCTF_68
VCC_AGX_NCTF_69
VCC_AGX_NCTF_70
VCC_AGX_NCTF_71
VCC_AGX_NCTF_72
VCC_AGX_NCTF_73
VCC_AGX_NCTF_74
VCC_AGX_NCTF_75
VCC_AGX_NCTF_76
VCC_AGX_NCTF_77
VCC_AGX_NCTF_78
VCC_AGX_NCTF_79
VCC_AGX_NCTF_80
VCC_AGX_NCTF_81
VCC_AGX_NCTF_82
VCC_AGX_NCTF_83

AW45 C170
BC39 C169
BE39 C171
BD17 C173
BD4 C172
AW8 C174
AT6 C175

CRESTLINE_1p0

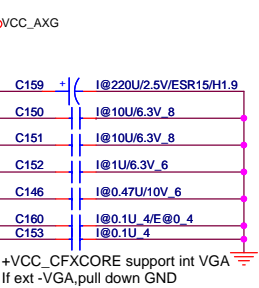

+VCC_CFXCORE support int VGA
If ext -VGA, pull down GND

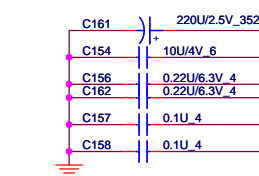

VCCP (0.54A)

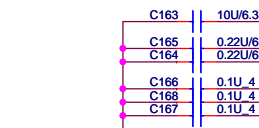

AW45 C170
BC39 C169
BE39 C171
BD17 C173
BD4 C172
AW8 C174
AT6 C175

CRESTLINE_1p0

VCCP (1.3A)
VCC_NCTF_1
VCC_NCTF_2
VCC_NCTF_3
VCC_NCTF_4
VCC_NCTF_5
VCC_NCTF_6
VCC_NCTF_7
VCC_NCTF_8
VCC_NCTF_9
VCC_NCTF_10
VCC_NCTF_11
VCC_NCTF_12
VCC_NCTF_13
VCC_NCTF_14
VCC_NCTF_15
VCC_NCTF_16
VCC_NCTF_17
VCC_NCTF_18
VCC_NCTF_19
VCC_NCTF_20
VCC_NCTF_21
VCC_NCTF_22
VCC_NCTF_23
VCC_NCTF_24
VCC_NCTF_25
VCC_NCTF_26
VCC_NCTF_27
VCC_NCTF_28
VCC_NCTF_29
VCC_NCTF_30
VCC_NCTF_31
VCC_NCTF_32
VCC_NCTF_33
VCC_NCTF_34
VCC_NCTF_35
VCC_NCTF_36
VCC_NCTF_37
VCC_NCTF_38
VCC_NCTF_39
VCC_NCTF_40
VCC_NCTF_41
VCC_NCTF_42
VCC_NCTF_43
VCC_NCTF_44
VCC_NCTF_45
VCC_NCTF_46
VCC_NCTF_47
VCC_NCTF_48
VCC_NCTF_49
VCC_NCTF_50

VCC AXM
VCC_AXM_1
VCC_AXM_2
VCC_AXM_3
VCC_AXM_4
VCC_AXM_5
VCC_AXM_6
VCC_AXM_7
VCC_AXM_NCTF_1
VCC_AXM_NCTF_2
VCC_AXM_NCTF_3
VCC_AXM_NCTF_4
VCC_AXM_NCTF_5
VCC_AXM_NCTF_6
VCC_AXM_NCTF_7
VCC_AXM_NCTF_8
VCC_AXM_NCTF_9
VCC_AXM_NCTF_10
VCC_AXM_NCTF_11
VCC_AXM_NCTF_12
VCC_AXM_NCTF_13
VCC_AXM_NCTF_14
VCC_AXM_NCTF_15
VCC_AXM_NCTF_16
VCC_AXM_NCTF_17
VCC_AXM_NCTF_18
VCC_AXM_NCTF_19

CRESTLINE_1p0

AW45 C170
BC39 C169
BE39 C171
BD17 C173
BD4 C172
AW8 C174
AT6 C175

CRESTLINE_1p0

VSS_NCTF_1
VSS_NCTF_2
VSS_NCTF_3
VSS_NCTF_4
VSS_NCTF_5
VSS_NCTF_6
VSS_NCTF_7
VSS_NCTF_8
VSS_NCTF_9
VSS_NCTF_10
VSS_NCTF_11
VSS_NCTF_12
VSS_NCTF_13
VSS_NCTF_14
VSS_NCTF_15
VSS_NCTF_16
VSS_NCTF_17
VSS_NCTF_18
VSS_NCTF_19
VSS_NCTF_20
VSS_NCTF_21
VSS_SCB1
VSS_SCB2
VSS_SCB3
VSS_SCB4
VSS_SCB5
VSS_SCB6

VSS SCB
VSS_SCB1
VSS_SCB2
VSS_SCB3
VSS_SCB4
VSS_SCB5
VSS_SCB6

VCC AXM
VCC_AXM_1
VCC_AXM_2
VCC_AXM_3
VCC_AXM_4
VCC_AXM_5
VCC_AXM_6
VCC_AXM_7

VCC AXM NCTF
VCC_AXM_NCTF_1
VCC_AXM_NCTF_2
VCC_AXM_NCTF_3
VCC_AXM_NCTF_4
VCC_AXM_NCTF_5
VCC_AXM_NCTF_6
VCC_AXM_NCTF_7
VCC_AXM_NCTF_8
VCC_AXM_NCTF_9
VCC_AXM_NCTF_10
VCC_AXM_NCTF_11
VCC_AXM_NCTF_12
VCC_AXM_NCTF_13
VCC_AXM_NCTF_14
VCC_AXM_NCTF_15
VCC_AXM_NCTF_16
VCC_AXM_NCTF_17
VCC_AXM_NCTF_18
VCC_AXM_NCTF_19

VCC AXM NCTF
VCC_AXM_NCTF_1
VCC_AXM_NCTF_2
VCC_AXM_NCTF_3
VCC_AXM_NCTF_4
VCC_AXM_NCTF_5
VCC_AXM_NCTF_6
VCC_AXM_NCTF_7
VCC_AXM_NCTF_8
VCC_AXM_NCTF_9
VCC_AXM_NCTF_10
VCC_AXM_NCTF_11
VCC_AXM_NCTF_12
VCC_AXM_NCTF_13
VCC_AXM_NCTF_14
VCC_AXM_NCTF_15
VCC_AXM_NCTF_16
VCC_AXM_NCTF_17
VCC_AXM_NCTF_18
VCC_AXM_NCTF_19

VCC AXM NCTF
VCC_AXM_NCTF_1
VCC_AXM_NCTF_2
VCC_AXM_NCTF_3
VCC_AXM_NCTF_4
VCC_AXM_NCTF_5
VCC_AXM_NCTF_6
VCC_AXM_NCTF_7
VCC_AXM_NCTF_8
VCC_AXM_NCTF_9
VCC_AXM_NCTF_10
VCC_AXM_NCTF_11
VCC_AXM_NCTF_12
VCC_AXM_NCTF_13
VCC_AXM_NCTF_14
VCC_AXM_NCTF_15
VCC_AXM_NCTF_16
VCC_AXM_NCTF_17
VCC_AXM_NCTF_18
VCC_AXM_NCTF_19

VCC AXM NCTF
VCC_AXM_NCTF_1
VCC_AXM_NCTF_2
VCC_AXM_NCTF_3
VCC_AXM_NCTF_4
VCC_AXM_NCTF_5
VCC_AXM_NCTF_6
VCC_AXM_NCTF_7
VCC_AXM_NCTF_8
VCC_AXM_NCTF_9
VCC_AXM_NCTF_10
VCC_AXM_NCTF_11
VCC_AXM_NCTF_12
VCC_AXM_NCTF_13
VCC_AXM_NCTF_14
VCC_AXM_NCTF_15
VCC_AXM_NCTF_16
VCC_AXM_NCTF_17
VCC_AXM_NCTF_18
VCC_AXM_NCTF_19

VCC AXM NCTF
VCC_AXM_NCTF_1
VCC_AXM_NCTF_2
VCC_AXM_NCTF_3
VCC_AXM_NCTF_4
VCC_AXM_NCTF_5
VCC_AXM_NCTF_6
VCC_AXM_NCTF_7
VCC_AXM_NCTF_8
VCC_AXM_NCTF_9
VCC_AXM_NCTF_10
VCC_AXM_NCTF_11
VCC_AXM_NCTF_12
VCC_AXM_NCTF_13
VCC_AXM_NCTF_14
VCC_AXM_NCTF_15
VCC_AXM_NCTF_16
VCC_AXM_NCTF_17
VCC_AXM_NCTF_18
VCC_AXM_NCTF_19

CRESTLINE_1p0

U5I
VSS_1
VSS_2
VSS_3
VSS_4
VSS_5
VSS_6
VSS_7
VSS_8
VSS_9
VSS_10
VSS_11
VSS_12
VSS_13
VSS_14
VSS_15
VSS_16
VSS_17
VSS_18
VSS_19
VSS_20
VSS_21
VSS_22
VSS_23
VSS_24
VSS_25
VSS_26
VSS_27
VSS_28
VSS_29
VSS_30
VSS_31
VSS_32
VSS_33
VSS_34
VSS_35
VSS_36
VSS_37
VSS_38
VSS_39
VSS_40
VSS_41
VSS_42
VSS_43
VSS_44
VSS_45
VSS_46
VSS_47
VSS_48
VSS_49
VSS_50
VSS_51
VSS_52
VSS_53
VSS_54
VSS_55
VSS_56
VSS_57
VSS_58
VSS_59
VSS_60
VSS_61
VSS_62
VSS_63
VSS_64
VSS_65
VSS_66
VSS_67
VSS_68
VSS_69
VSS_70
VSS_71
VSS_72
VSS_73
VSS_74
VSS_75
VSS_76
VSS_77
VSS_78
VSS_79
VSS_80
VSS_81
VSS_82
VSS_83
VSS_84
VSS_85
VSS_86
VSS_87
VSS_88
VSS_89
VSS_90
VSS_91
VSS_92
VSS_93
VSS_94
VSS_95
VSS_96
VSS_97
VSS_98
VSS_99
VSS_100
VSS_101
VSS_102
VSS_103
VSS_104
VSS_105
VSS_106
VSS_107
VSS_108
VSS_109
VSS_110
VSS_111
VSS_112
VSS_113
VSS_114
VSS_115
VSS_116
VSS_117
VSS_118
VSS_119
VSS_120
VSS_121
VSS_122
VSS_123
VSS_124
VSS_125
VSS_126
VSS_127
VSS_128
VSS_129
VSS_130
VSS_131
VSS_132
VSS_133
VSS_134
VSS_135
VSS_136
VSS_137
VSS_138
VSS_139
VSS_140
VSS_141
VSS_142
VSS_143
VSS_144
VSS_145
VSS_146
VSS_147
VSS_148
VSS_149
VSS_150
VSS_151
VSS_152
VSS_153
VSS_154
VSS_155
VSS_156
VSS_157
VSS_158
VSS_159
VSS_160
VSS_161
VSS_162
VSS_163
VSS_164
VSS_165
VSS_166
VSS_167
VSS_168
VSS_169
VSS_170
VSS_171
VSS_172
VSS_173
VSS_174
VSS_175
VSS_176
VSS_177
VSS_178
VSS_179
VSS_180
VSS_181
VSS_182
VSS_183
VSS_184
VSS_185
VSS_186
VSS_187
VSS_188
VSS_189
VSS_190
VSS_191
VSS_192
VSS_193
VSS_194
VSS_195
VSS_196
VSS_197
VSS_198
VSS_199
VSS_200
VSS_201
VSS_202
VSS_203
VSS_204
VSS_205
VSS_206
VSS_207
VSS_208
VSS_209
VSS_210
VSS_211
VSS_212
VSS_213
VSS_214
VSS_215
VSS_216
VSS_217
VSS_218
VSS_219
VSS_220
VSS_221
VSS_222
VSS_223
VSS_224
VSS_225
VSS_226
VSS_227
VSS_228
VSS_229
VSS_230
VSS_231
VSS_232
VSS_233
VSS_234
VSS_235
VSS_236
VSS_237
VSS_238
VSS_239
VSS_240
VSS_241
VSS_242
VSS_243
VSS_244
VSS_245
VSS_246
VSS_247
VSS_248
VSS_249
VSS_250
VSS_251
VSS_252
VSS_253
VSS_254
VSS_255
VSS_256
VSS_257
VSS_258
VSS_259
VSS_260
VSS_261
VSS_262
VSS_263
VSS_264
VSS_265
VSS_266
VSS_267
VSS_268
VSS_269
VSS_270
VSS_271
VSS_272
VSS_273
VSS_274
VSS_275
VSS_276
VSS_277
VSS_278
VSS_279
VSS_280
VSS_281
VSS_282
VSS_283
VSS_284
VSS_285
VSS_286

CRESTLINE_1p0

U5J
VSS_199
VSS_200
VSS_201
VSS_202
VSS_203
VSS_204
VSS_205
VSS_206
VSS_207
VSS_208
VSS_209
VSS_210
VSS_211
VSS_212
VSS_213
VSS_214
VSS_215
VSS_216
VSS_217
VSS_218
VSS_219
VSS_220
VSS_221
VSS_222
VSS_223
VSS_224
VSS_225
VSS_226
VSS_227
VSS_228
VSS_229
VSS_230
VSS_231
VSS_232
VSS_233
VSS_234
VSS_235
VSS_236
VSS_237
VSS_238
VSS_239
VSS_240
VSS_241
VSS_242
VSS_243
VSS_244
VSS_245
VSS_246
VSS_247
VSS_248
VSS_249
VSS_250
VSS_251
VSS_252
VSS_253
VSS_254
VSS_255
VSS_256
VSS_257
VSS_258
VSS_259
VSS_260
VSS_261
VSS_262
VSS_263
VSS_264
VSS_265
VSS_266
VSS_267
VSS_268
VSS_269
VSS_270
VSS_271
VSS_272
VSS_273
VSS_274
VSS_275
VSS_276
VSS_277
VSS_278
VSS_279
VSS_280
VSS_281
VSS_282
VSS_283
VSS_284
VSS_285
VSS_286
VSS_287
VSS_288
VSS_289
VSS_290
VSS_291
VSS_292
VSS_293
VSS_294
VSS_295
VSS_296
VSS_297
VSS_298
VSS_299
VSS_300
VSS_301
VSS_302
VSS_303
VSS_304
VSS_305
VSS_306
VSS_307
VSS_308
VSS_309
VSS_310
VSS_311
VSS_312
VSS_313
VSS_314
VSS_315
VSS_316
VSS_317
VSS_318
VSS_319
VSS_320
VSS_321
VSS_322
VSS_323
VSS_324
VSS_325
VSS_326
VSS_327
VSS_328
VSS_329
VSS_330
VSS_331
VSS_332
VSS_333
VSS_334
VSS_335
VSS_336
VSS_337
VSS_338
VSS_339
VSS_340
VSS_341
VSS_342
VSS_343
VSS_344
VSS_345
VSS_346
VSS_347
VSS_348
VSS_349
VSS_350
VSS_351
VSS_352
VSS_353
VSS_354
VSS_355
VSS_356
VSS_357
VSS_358
VSS_359
VSS_360
VSS_361
VSS_362
VSS_363
VSS_364
VSS_365
VSS_366
VSS_367
VSS_368
VSS_369
VSS_370
VSS_371
VSS_372
VSS_373
VSS_374
VSS_375
VSS_376
VSS_377
VSS_378
VSS_379
VSS_380
VSS_381
VSS_382
VSS_383
VSS_384
VSS_385
VSS_386
VSS_387
VSS_388
VSS_389
VSS_390
VSS_391
VSS_392
VSS_393
VSS_394
VSS_395
VSS_396
VSS_397
VSS_398
VSS_399
VSS_400

CRESTLINE_1p0



Title			
GMCH Power 4 of 5			
Size	Document Number	Rev	
	GD1B Main Board	2A	
Date:	Monday, August 20, 2007	Sheet	8 of 35

1. Level 1 Environment-related Substances Should NEVER be Used.
2. Purchase ink, paint, wire rods, and Molding resins only from the business Partners that Any Approves as Green Partners.

CRT

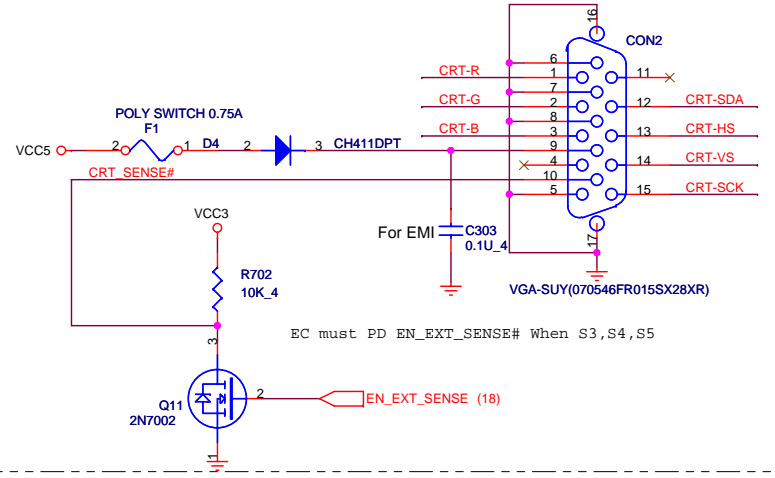
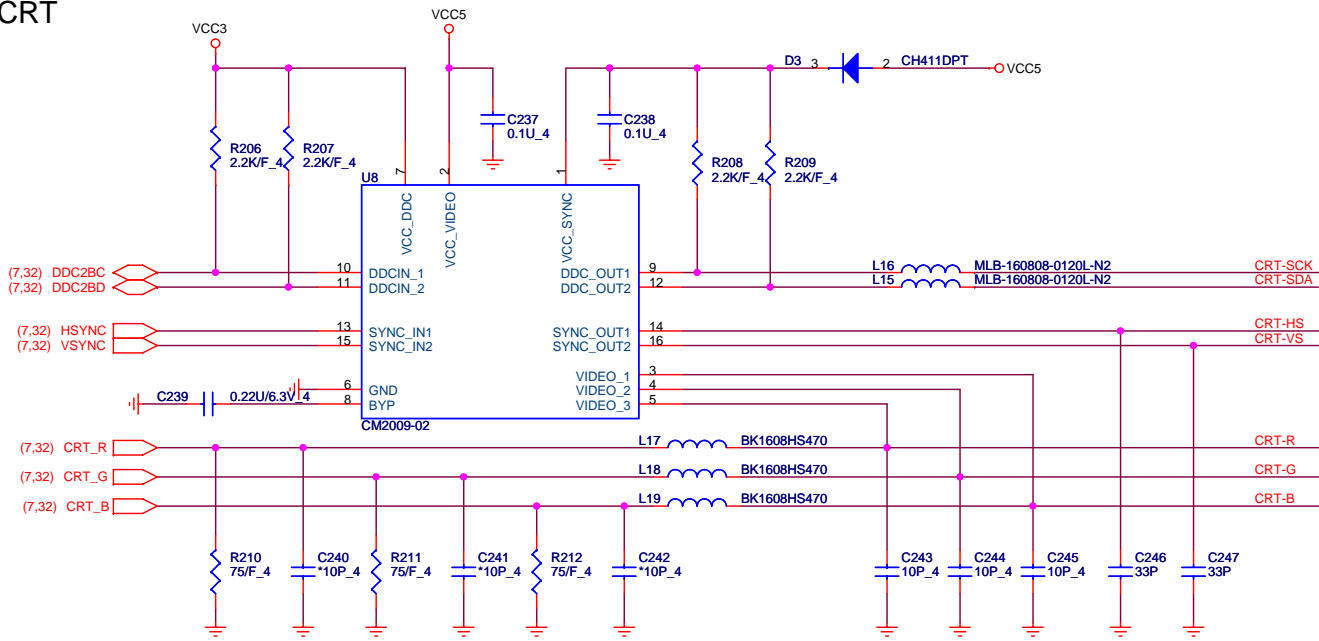

S-VIDEO_OUT

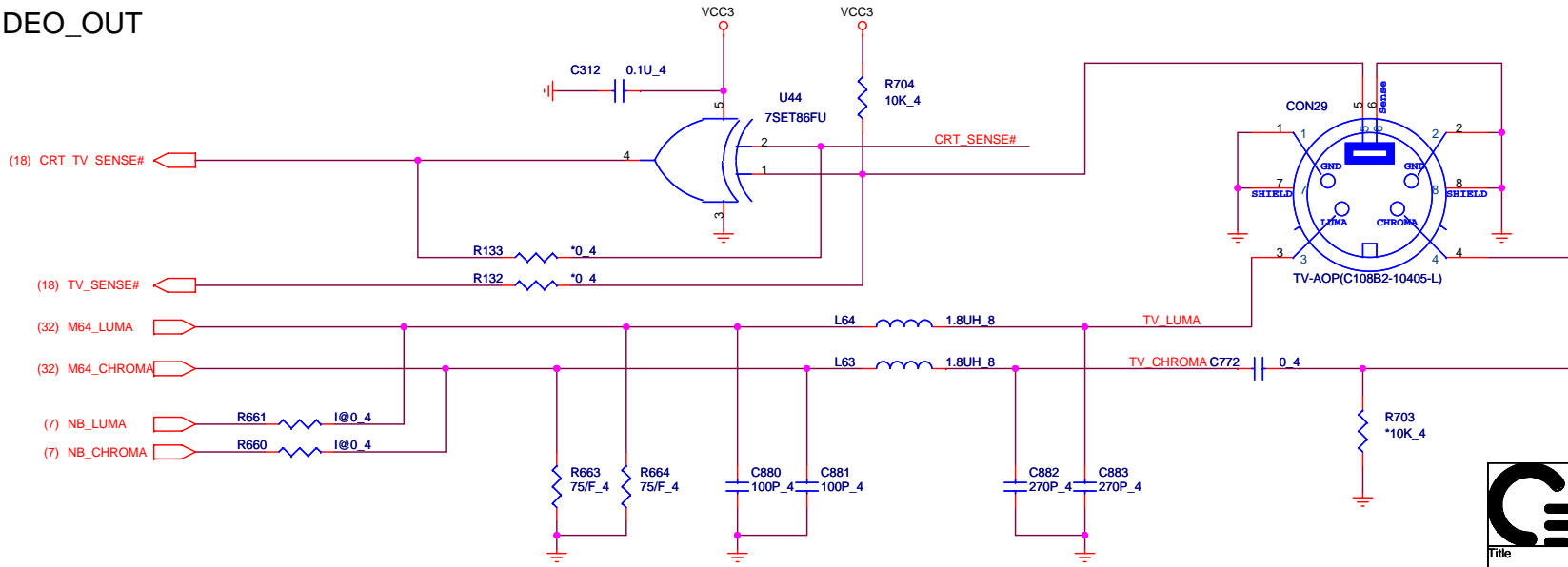

QUANTA COMPUTER

Title: **CRT & S-VIDEO**

Size B Document Number: **GD1B Main Board** Rev 2A

Date: Monday, August 20, 2007 Sheet 10 of 35

1.Level 1 Environment-related Substances Should NEVER be Used.
 2.Purchase ink, paint, wire rods, and Molding resins only from the business Partners that Sony approves as Green Partners.

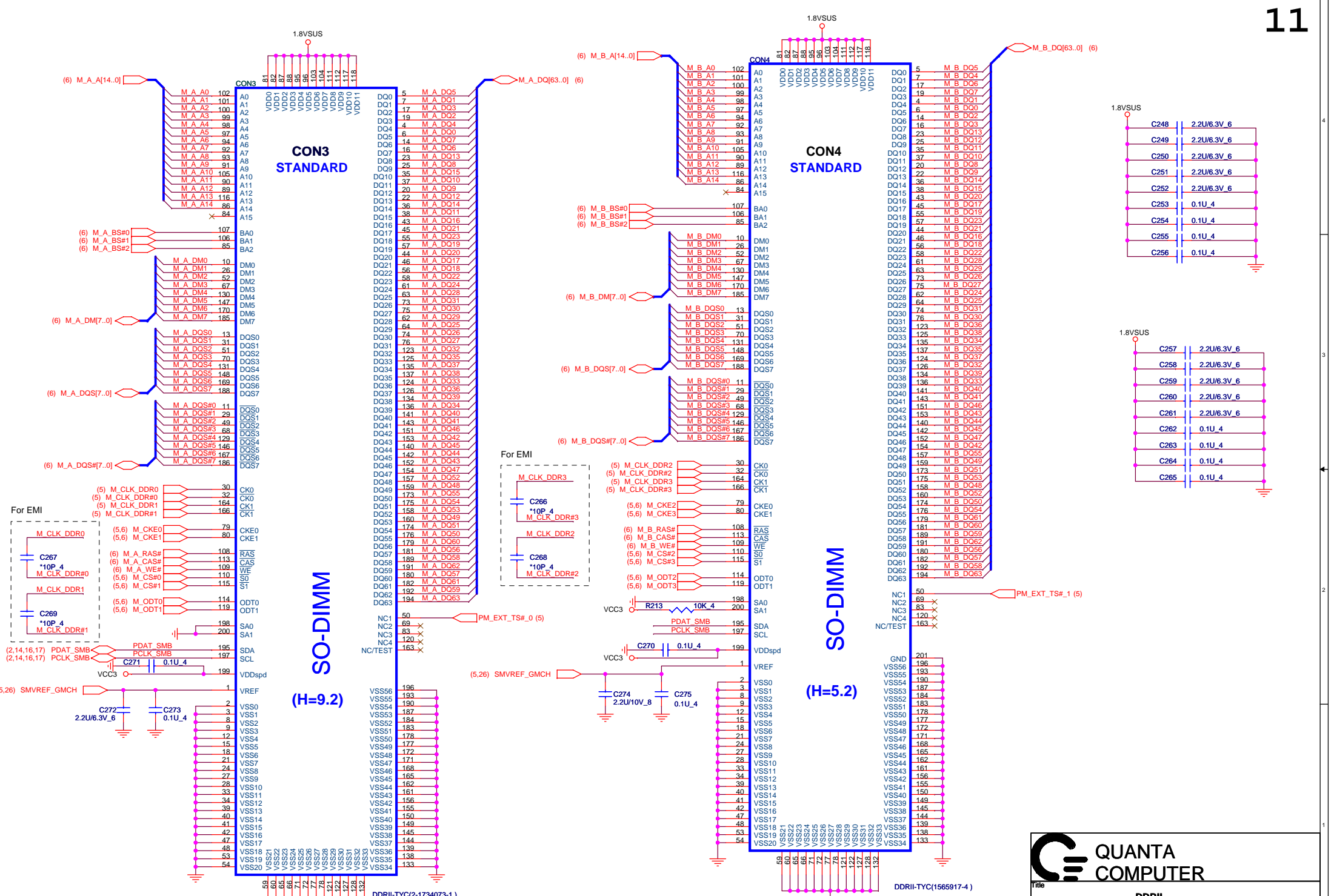

QUANTA COMPUTER

Title: **DDRII**

Size: **GD1A Main Board**

Date: **Tuesday, September 04, 2007**

Rev: **2A**

Sheet: **11** of **35**

RTC

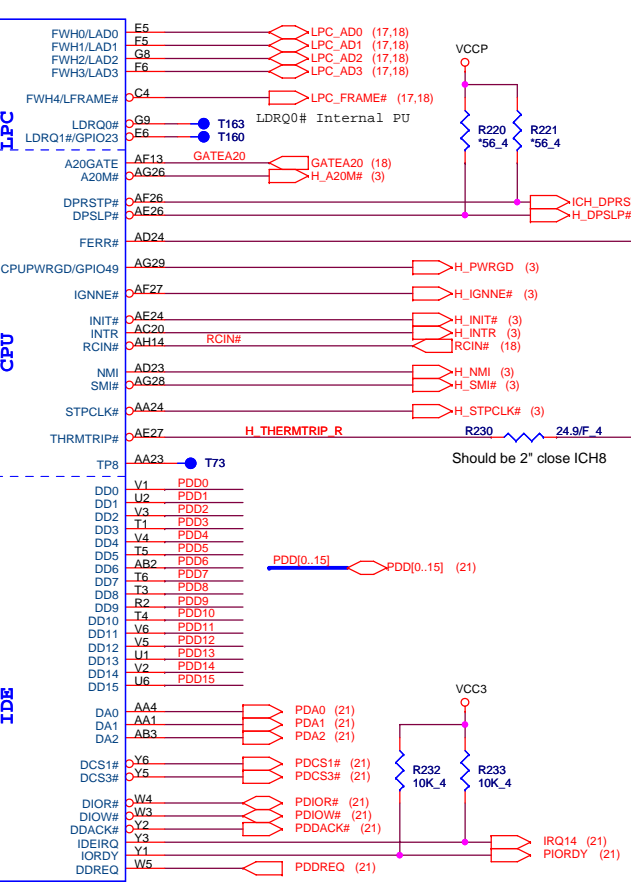
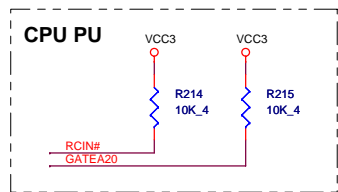
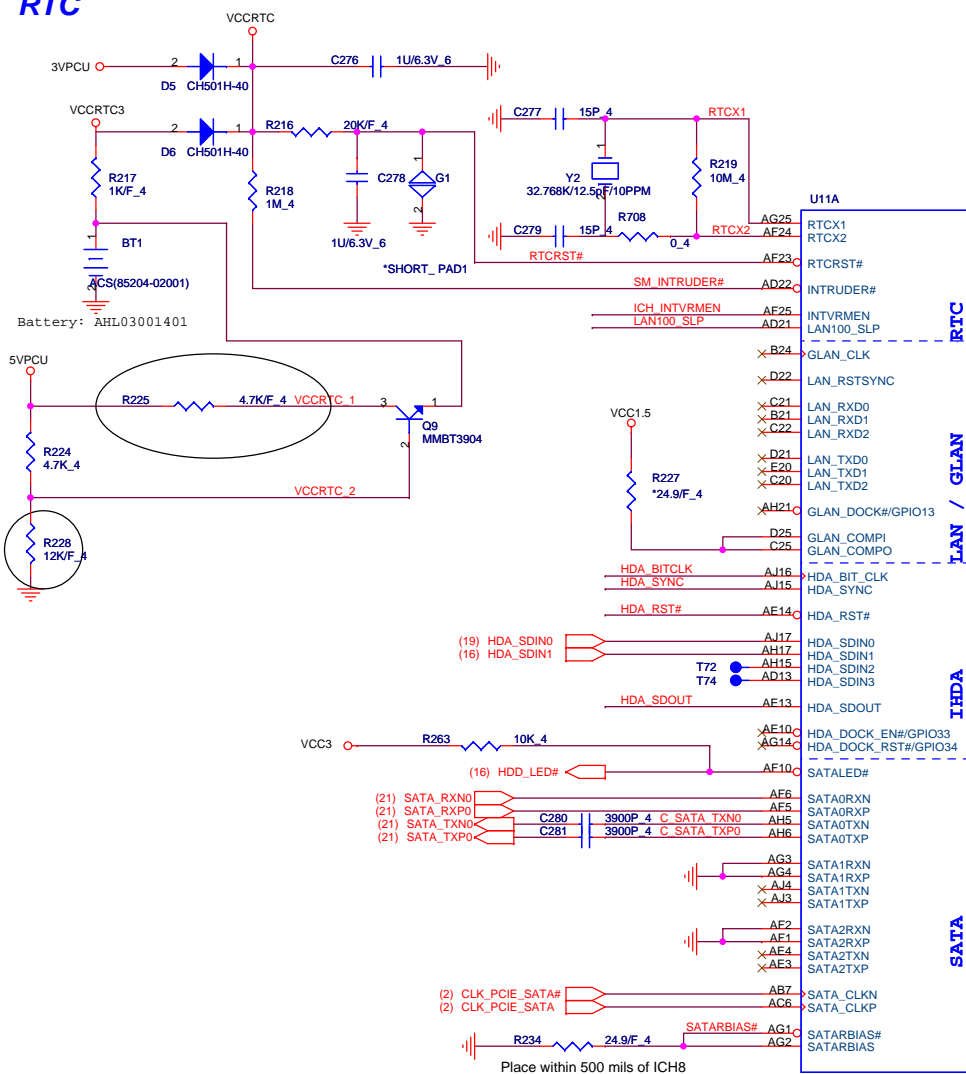

XOR Chain Entrance Strap

ICH_RSV0	HDA_SDOUT	Description
0	0	RSVD
0	1	Enter XOR Chain
1	0	Normal operation(Default)
1	1	Set PCIe port config bit 1

ICH8 strap

ICH8-M LAN100_SLP Strap
(Internal VR for VccLAN1_05 and VccCL1_05)

LAN100_SLP	Low = Internal VR disable High = Internal VR enable(Default)
------------	---

ICH_INTVRMEN	Low = Disable High = Enable(Default)
--------------	---

ICH8-M Internal VR Enable strap
(Internal VR for Vccsus1_05, VccSus1_5 and VccCL1_5)

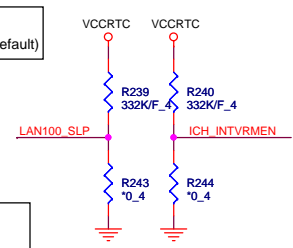

HD Audio to Codec and Modem

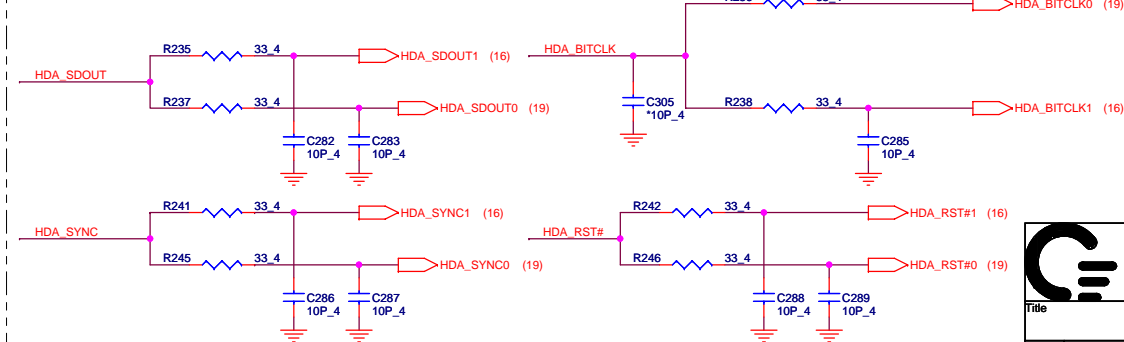

1.Level 1 Environment-related Substances Should NEVER be Used.
2.Purchase ink, paint, wire rods, and Molding resins only from the business Partners that Sony approves as Green Partners.

QUANTA COMPUTER

Title: ICH8-M HOST 1 of 4

Size: Document Number: GD1B Main Board Rev 3A

Date: Monday, August 20, 2007 Sheet 12 of 35

WireLess Lan

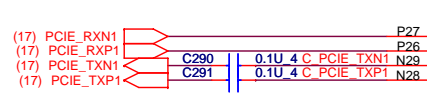

Express card

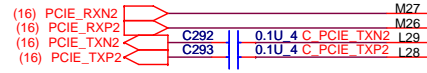

10/100 Lan

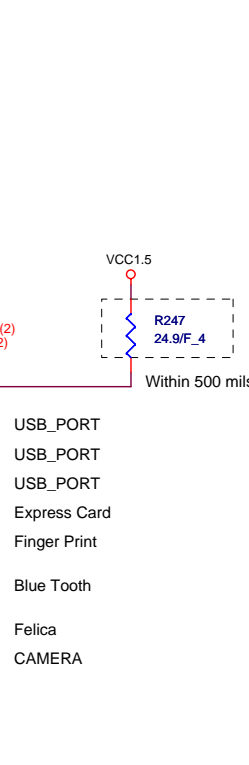
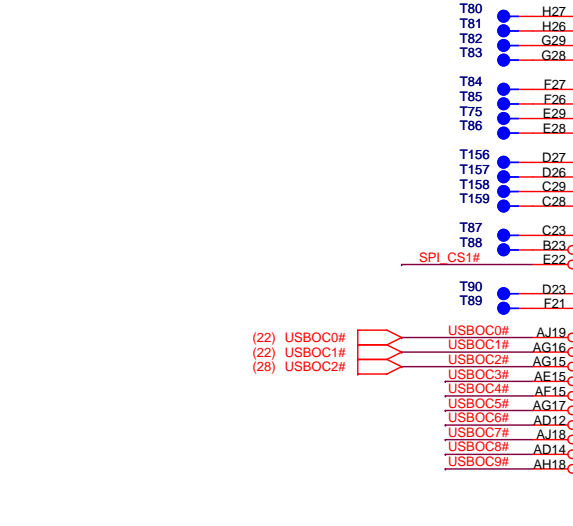
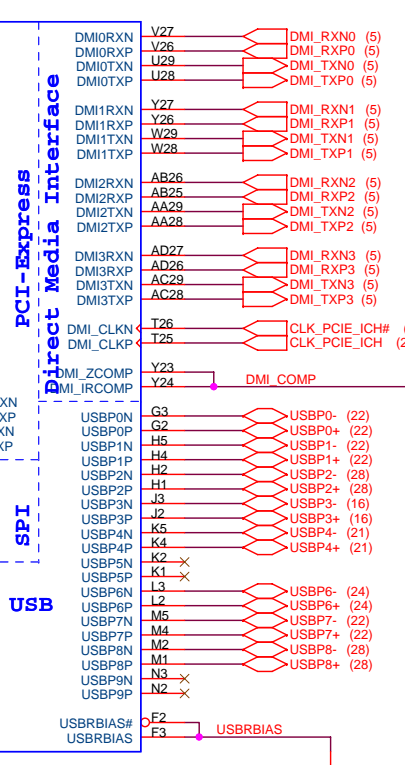
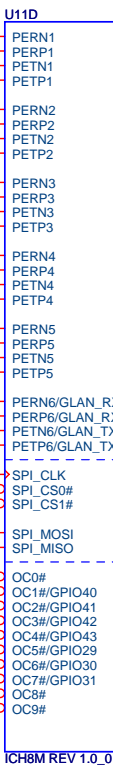
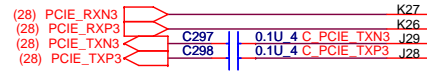

PCI bus info.

PCI DEVICE	IDSEL#	REQ# / GNT#	Interrupts
T18402	AD23	REQ0# / GNT0#	PIRQ E/F/G

A16 SWAP Override strap

PCI_GNT#3	Low = A16 swap override enabled High = Default
-----------	---



ICH8 Boot BIOS select

PCI_GNT#0	SPI_CS#1	Boot BIOS Location
0	1	SPI
1	0	PCI
1	1	LPC(Default)

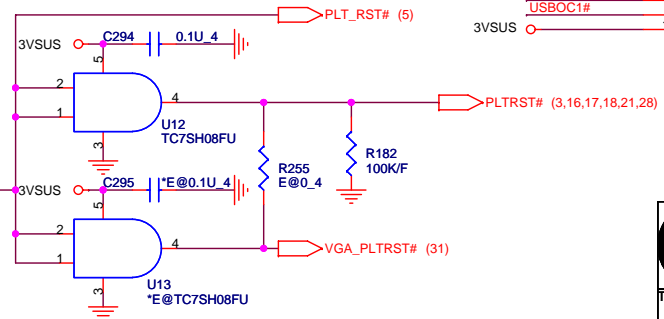
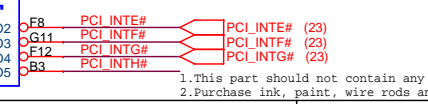
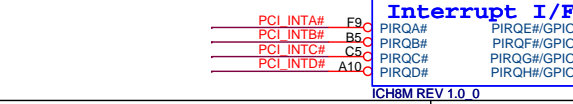
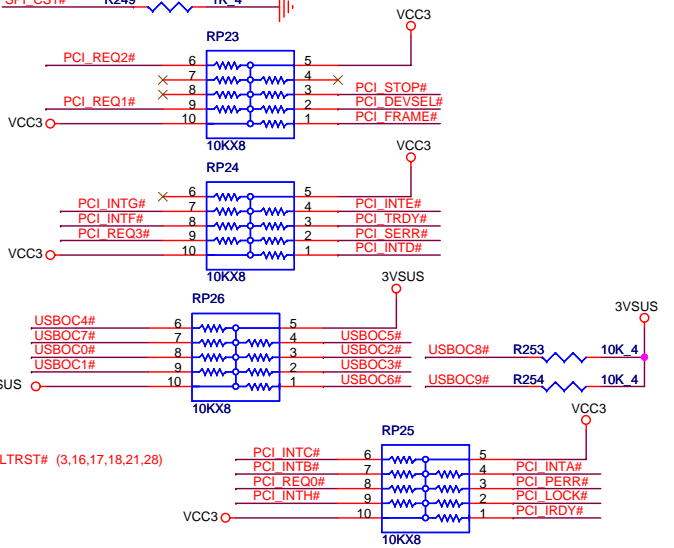
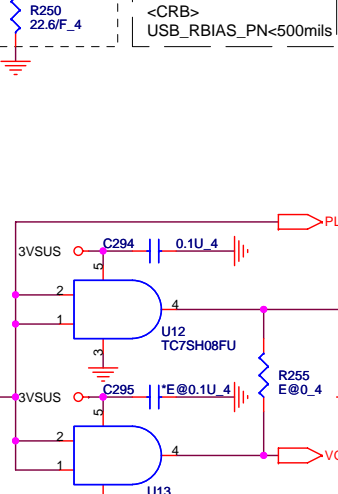
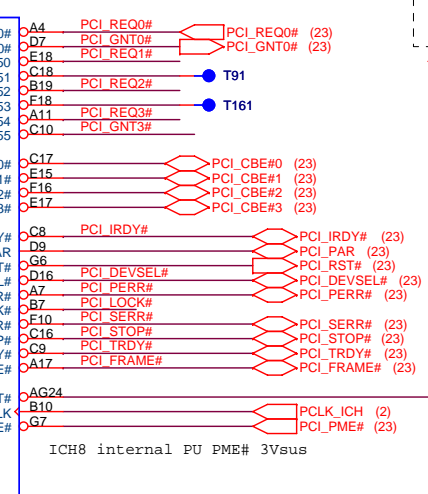
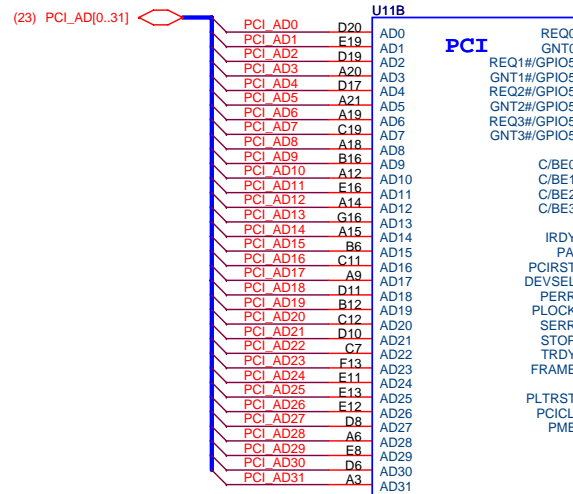

QUANTA COMPUTER

Title: **ICH8-M PCIE 2 of 4**

Size B Document Number: **GD1B Main Board** Rev 2A

Date: Monday, August 20, 2007 Sheet 13 of 35

1. This part should not contain any substances which are specified in SS-00259-1
 2. Purchase ink, paint, wire rods and molding resins only from the business partners that Sony approves as Green Partners.

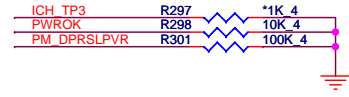
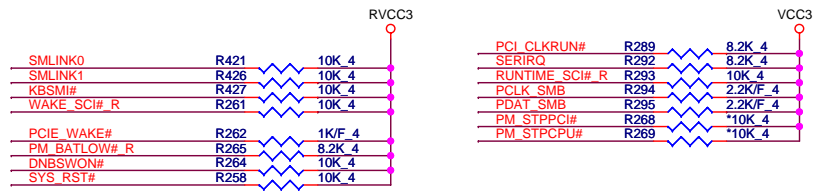

RSMRST# must be after RVCC3 10 ms

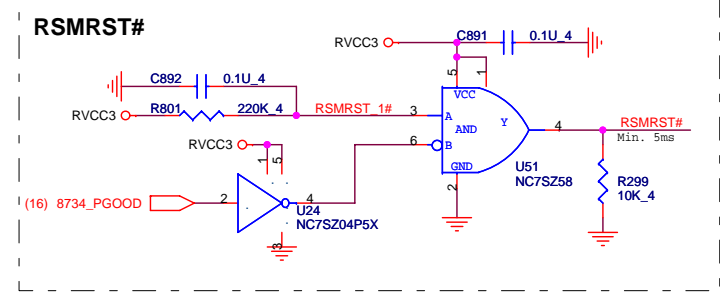

LCDID	Panel Type
X001	AUO -QD14TL0206
X010	CPT -CLAA141WB02A
X011	CPT -CLAA141WB05A

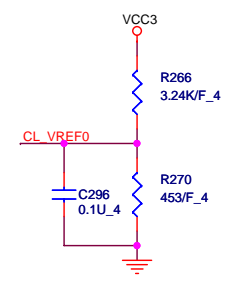
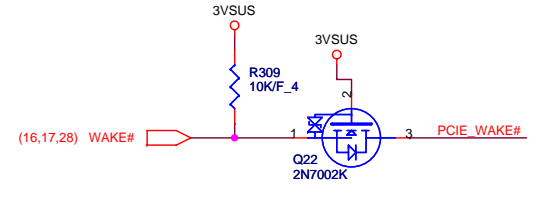
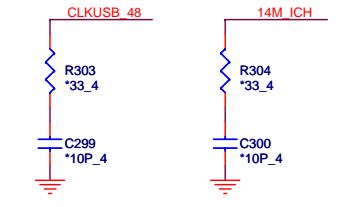
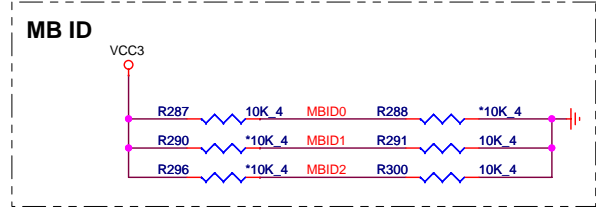
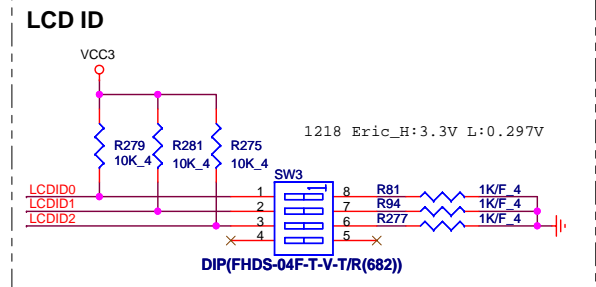
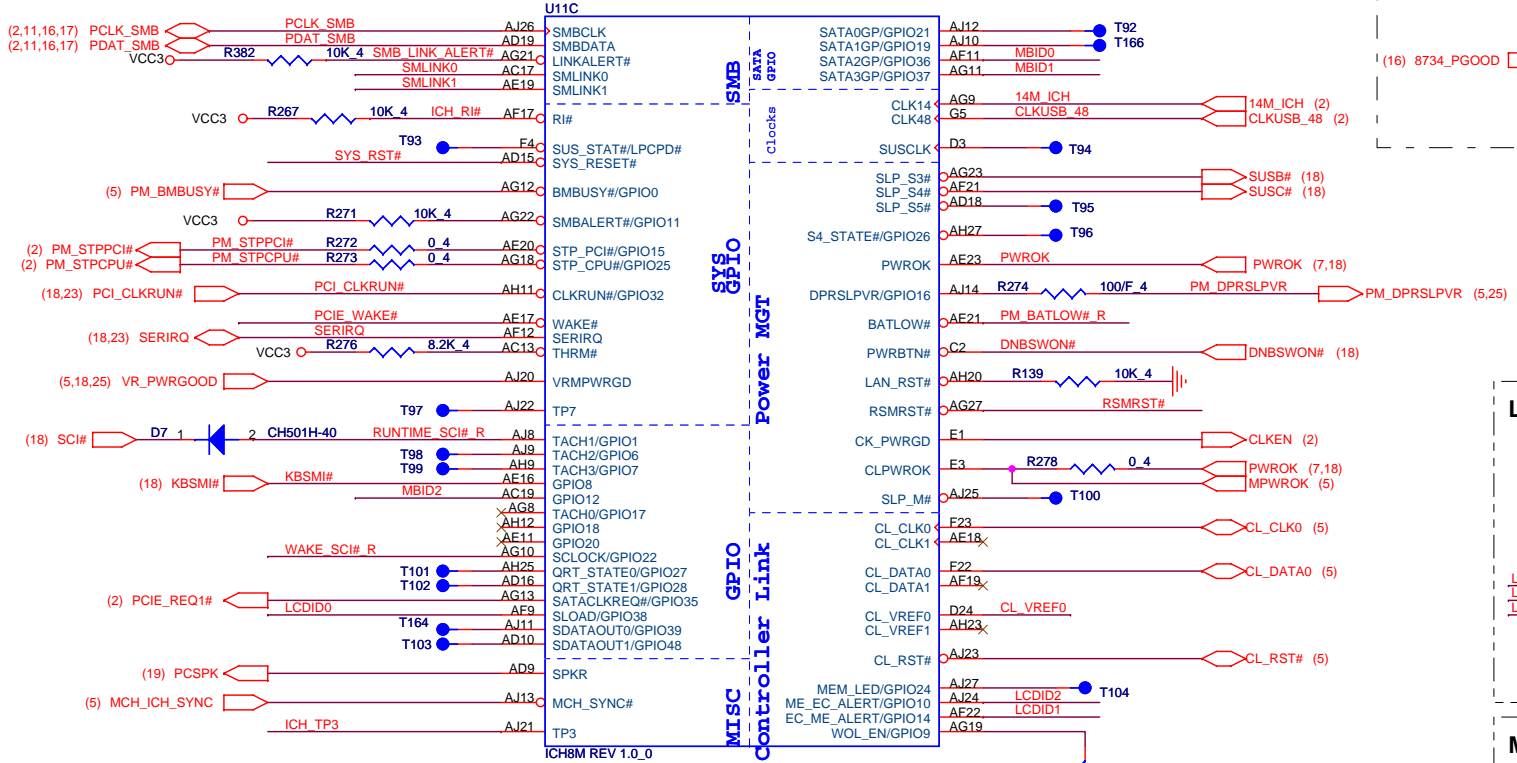

1.Level 1 Environment-related Substances Should NEVER be Used.
2.Purchase ink, paint, wire rods, and Molding resins only from the business Partners that Sony approves as Green Partners.

QUANTA COMPUTER

Title: ICH8-M GPIO 3 of 4

Size B	Document Number	Rev 2A
GD1B Main Board		
Date: Monday, August 20, 2007	Sheet 14	of 35

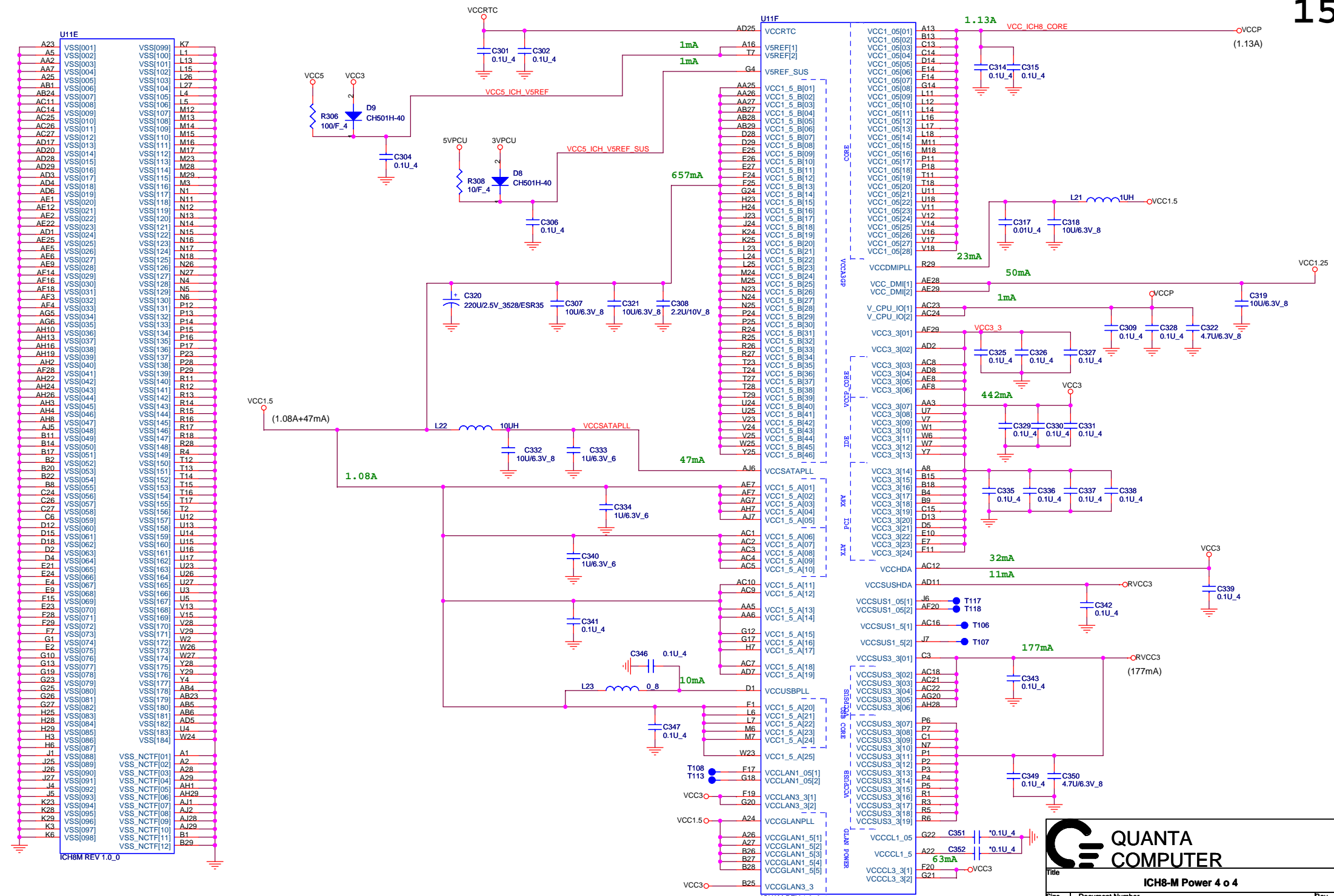

hexainf@hotmail.com
 GRATIS - FOR FREE

1.Level 1 Environment-related Substances Should NEVER be Used.
 2.Purchase ink, paint, wire rods, and Welding resins only from the business Partners that Sony approves as Green Partners.

QUANTA COMPUTER

Title: **ICH8-M Power 4 o 4**

Size	Document Number	Rev
	GD1B Main Board	2A
Date:	Monday, August 20, 2007	Sheet 15 of 35

Express Board CON1(BTB)

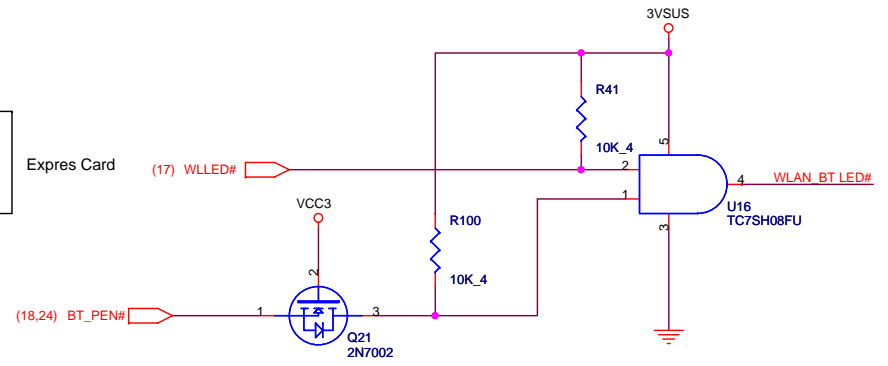
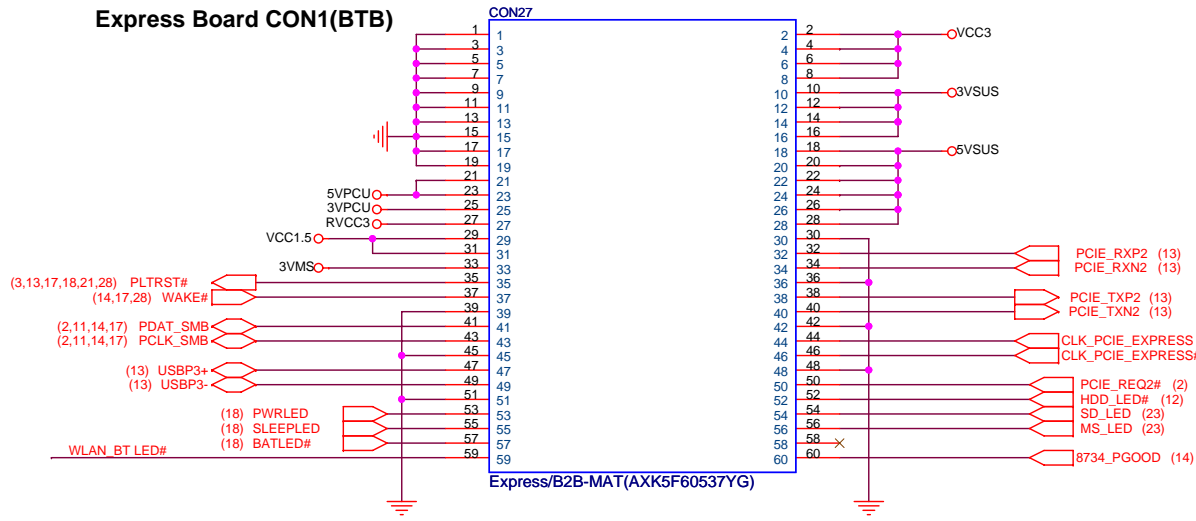

Express Board CON2(BTB)

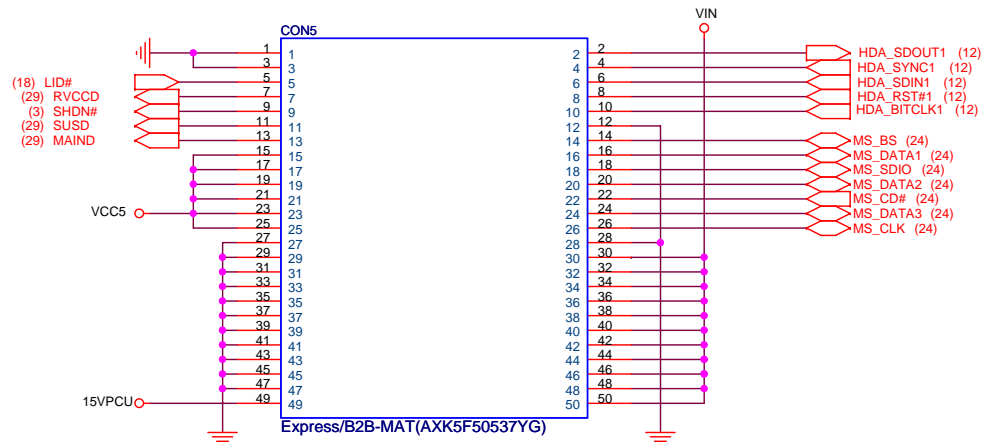

Fan Unit

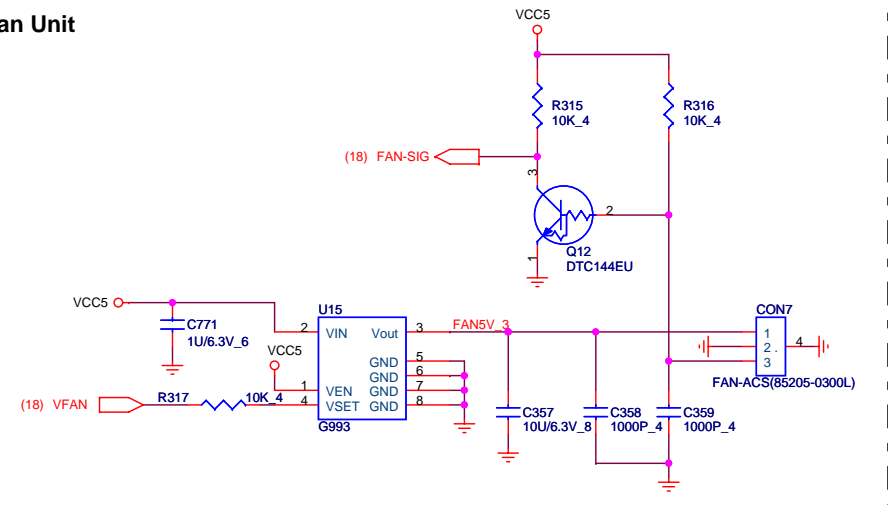

Title			Express Card		
Size	Document Number				Rev
B	GD1B Main Board				2A
Date:	Monday, August 20, 2007	Sheet	16	of	35

1. This part should not contain any substances which are specified in SS-00259-1
 2. Purchase ink, paint, wire rods and molding resins only from the business partners that Sony approves as Green Partners.

LED_GP :LED WLEN LINK
 Output Current : 7mA
 Blink rate : 1 flash per every 3 sec.

WLSW:
 Low : disable the radio.
 High : Enable the radio.

Mini PCI-E Card FOR WL

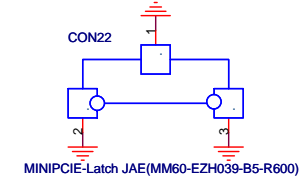
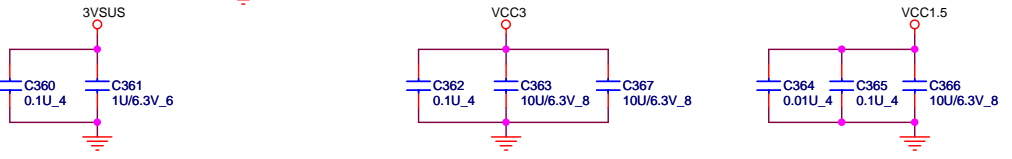
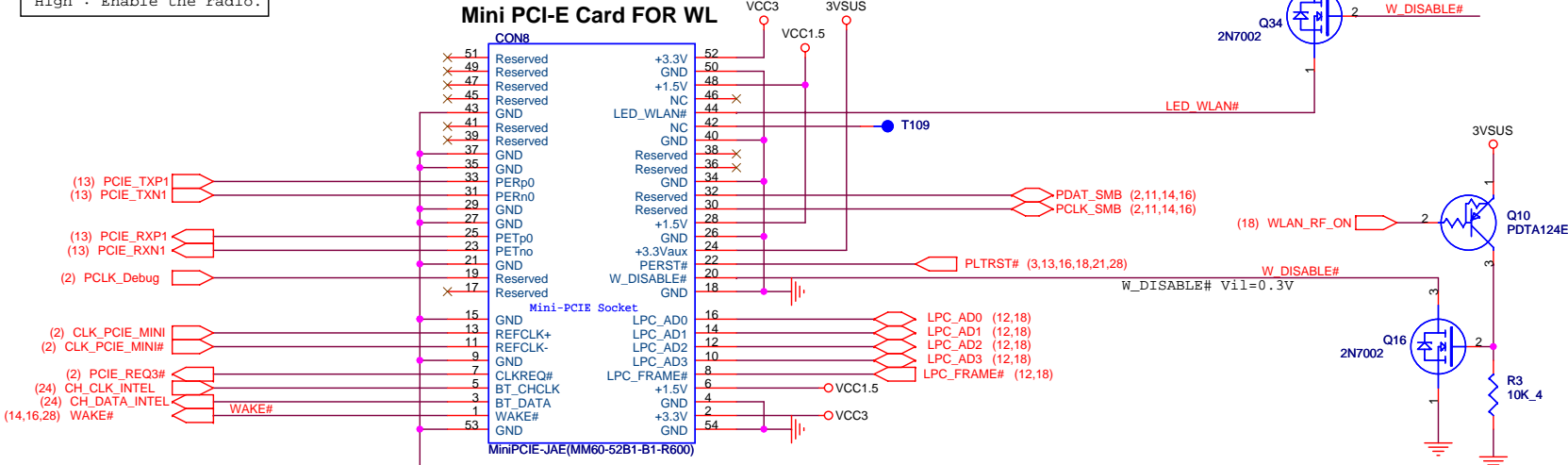

1.Level 1 Environment-related Substances Should NEVER be Used.
 2.Purchase ink, paint, wire rods, and Molding resins only from the business Partners that Sony approves as Green Partners.

QUANTA COMPUTER		
Title: MINIPCI-E / MDC		
Size: B	Document Number: GD1B Main Board	Rev: 2A
Date: Monday, August 20, 2007 Sheet 17 of 35		

SPI Flash

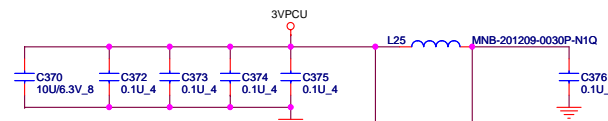
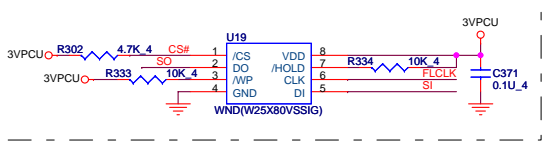

I/O Address		
BADDR1-0	Index	Data
1 0	2E	2F
1 1	4E	4F
0 0	[HCFGBAH, HCFGBAL] [HCFGBAH, HCFGBAL]+1	
0 1	XOR-TREE TEST	

DOCX_RST# = BADDR0
 BK_BAT_PWREN = BADDR1
 BT_PEN# : SHBM(If = 0 Enable share host BIOS memory)

PWROK must be after HWPG at least 10ms
 VRON must be after PGOOD at least 99ms
 MAINON <-- 3ms --> MAION1
 MAINON <-- 3.5ms --> MAION2

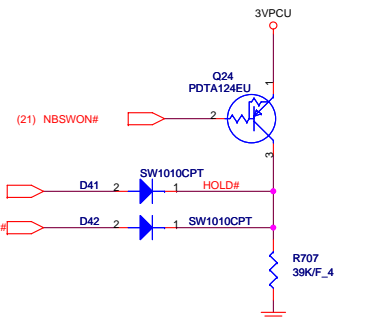
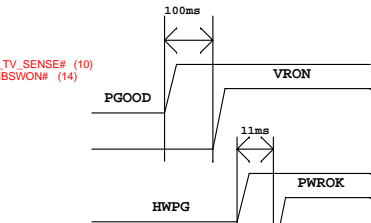
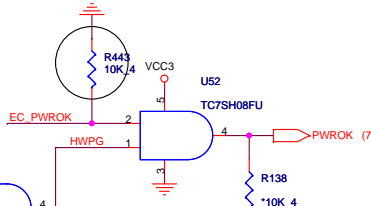
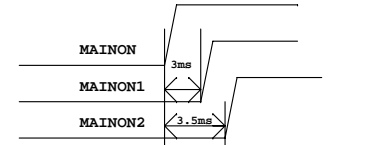
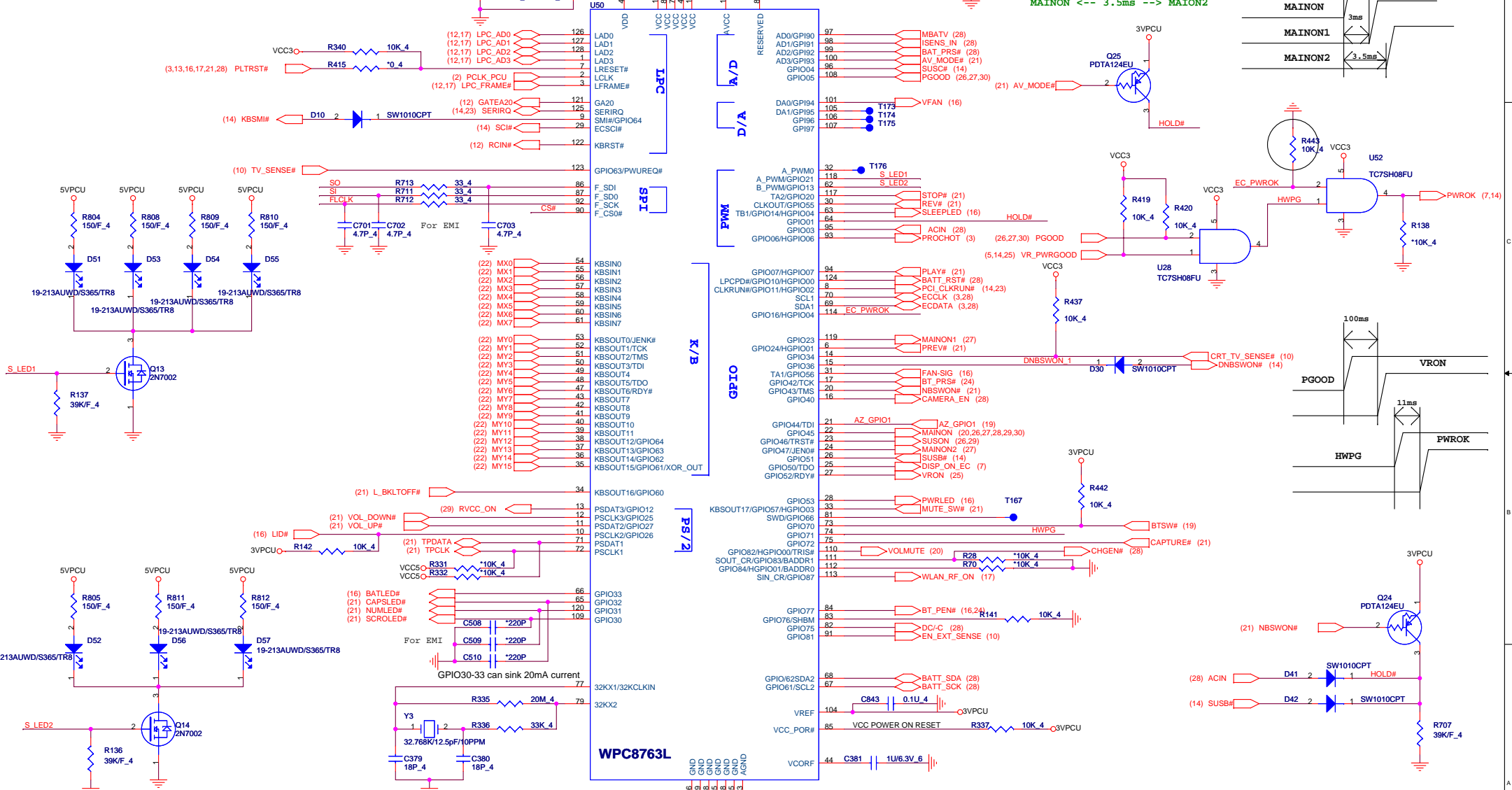

JTAG SELECT CONFIGURATION

JEN0(PIN24)	JENK(PIN53)	Functionality of PINs (17,20,21,23,25,27)	Functionality of PINs (47,48,50,51,52)
NC	NC	GPIO	KEYBOARD OUTPUT
10K PD	NC	JTAG Signal	KEYBOARD OUTPUT
NC	10K PD	GPIO	JTAG Signal
10K PD	10K PD		Illegal Strap combination

1.Level 1 Environment-related Substances should NEVER be Used.
 2.Purchase ink, paint, wire rods, and Molding resins only from the business Partners that Sony approves as Green Partners.

QUANTA COMPUTER

Title: **WPC8763L & SPI FLASH**

Size: Document Number: **GD1B Main Board** Rev 2A

Date: Monday, August 20, 2007 Sheet 18 of 35

Audio decoupling

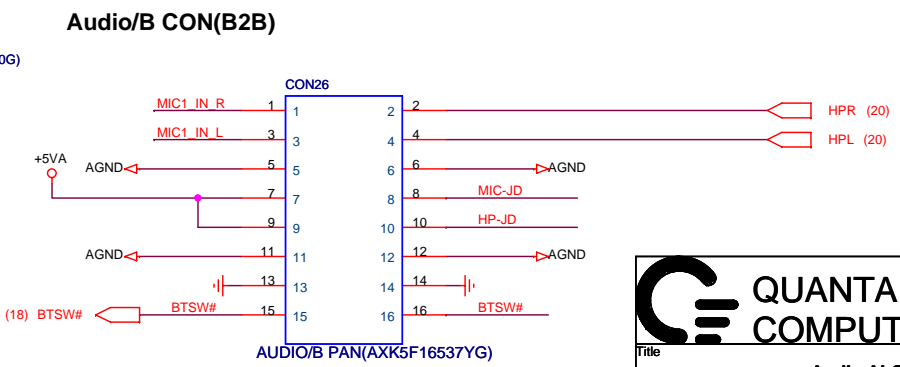
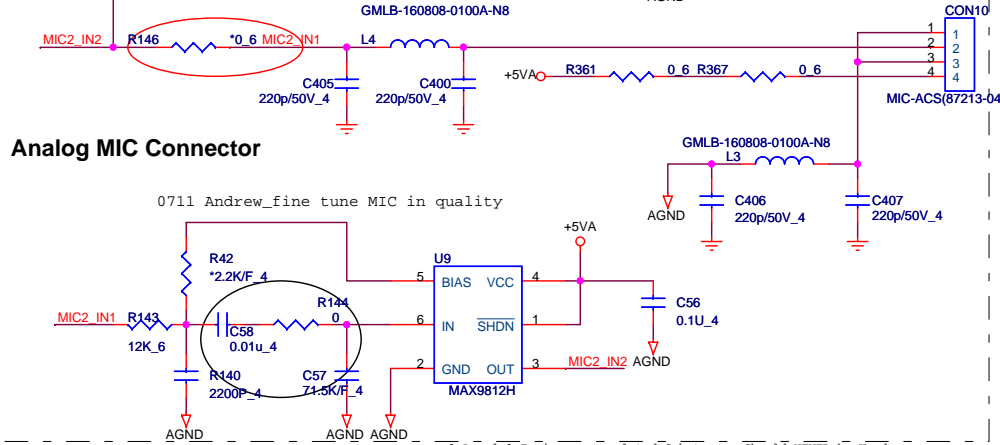
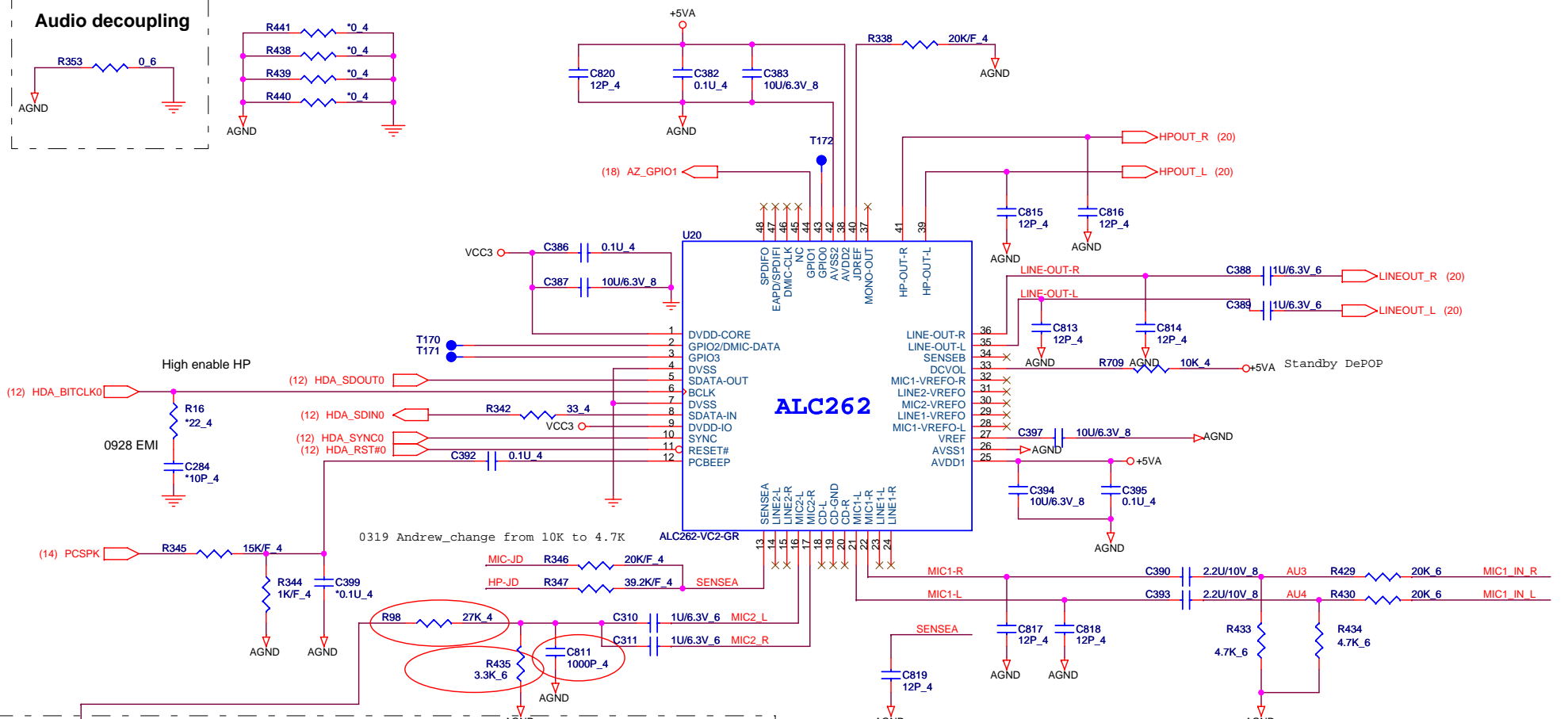
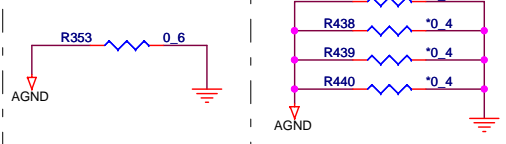

1. Level 1 Environment-related Substances Should NEVER be Used.
 2. Purchase ink, paint, wire rods, and Molding resins only from the business Partners that Sony approves as Green Partners.

QUANTA COMPUTER

Title: **Audio ALC268**

Size: Custom	Document Number: GD1B Main Board	Rev: 2A
Date: Wednesday, August 22, 2007	Sheet: 19 of 35	

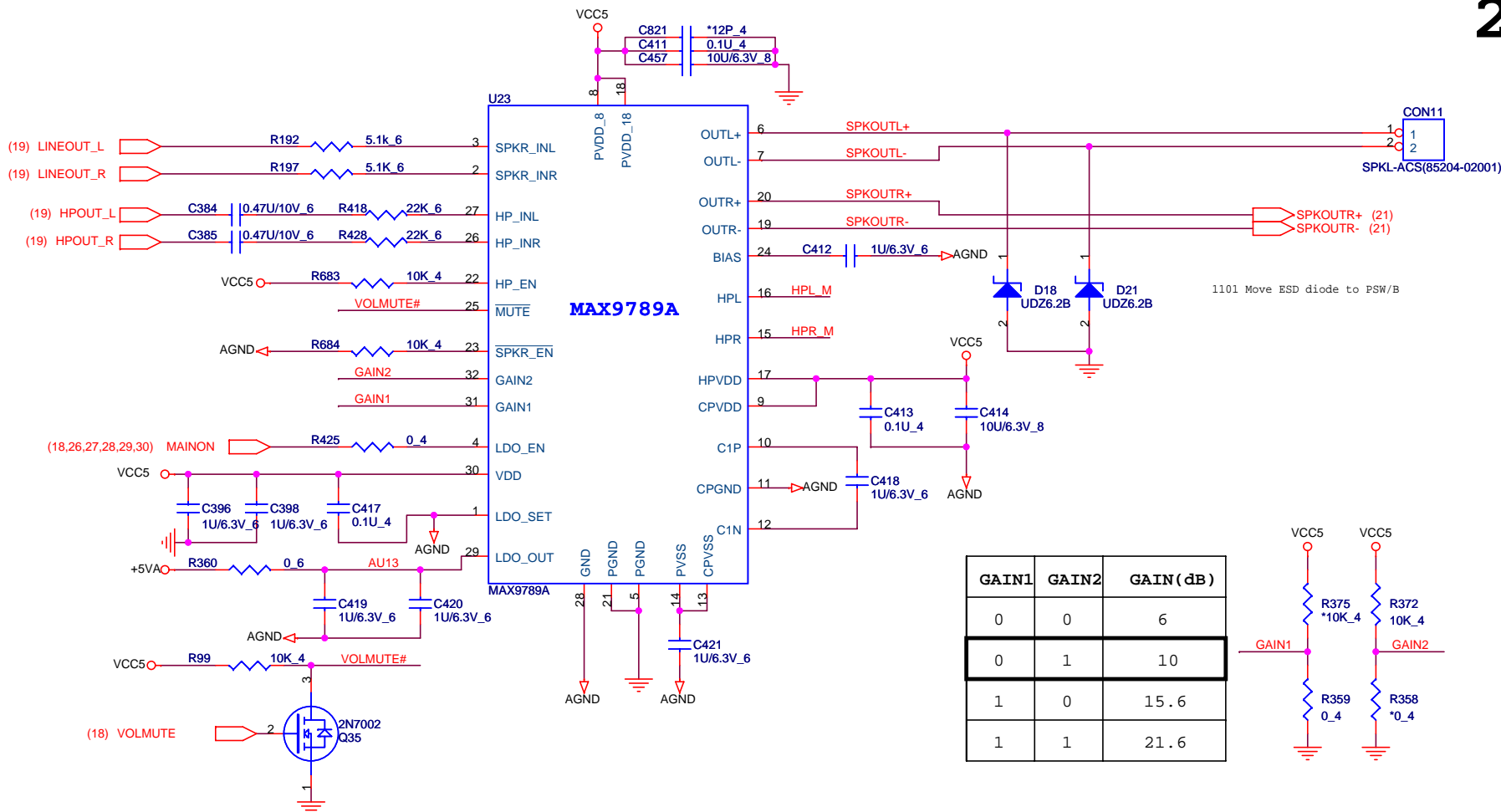

Headphone MUTE

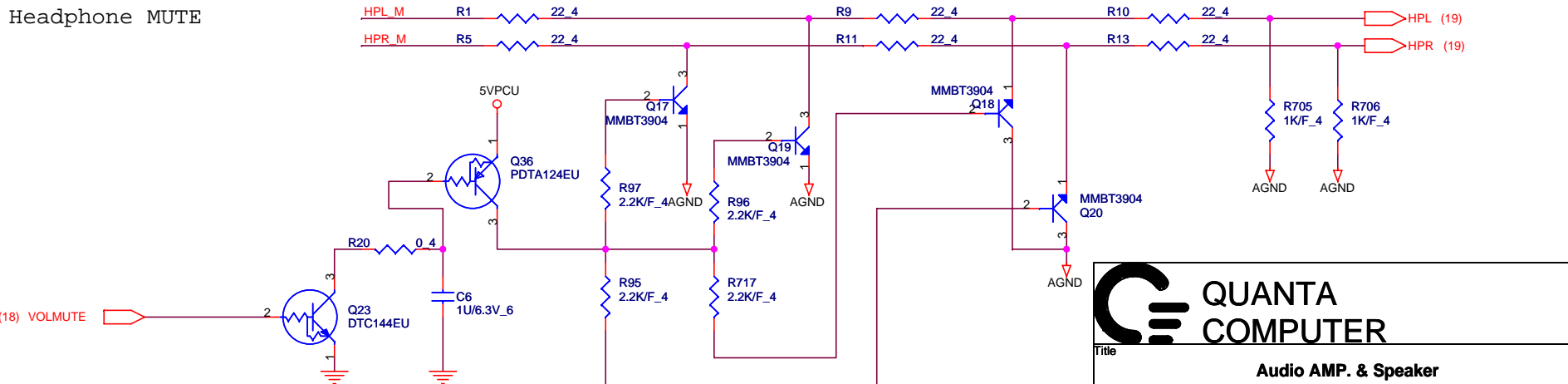

1.Level 1 Environment-related Substances Should NEVER be Used.
 2.Purchase ink, paint, wire rods, and Molding resins only from the business Partners that Sony approves as Green Partners.



**QUANTA
COMPUTER**

Title: **Audio AMP. & Speaker**

Size Custom	Document Number GD1B Main Board	Rev 2A
Date: Monday, August 20, 2007		Sheet 20 of 35

ODD CONNECTOR

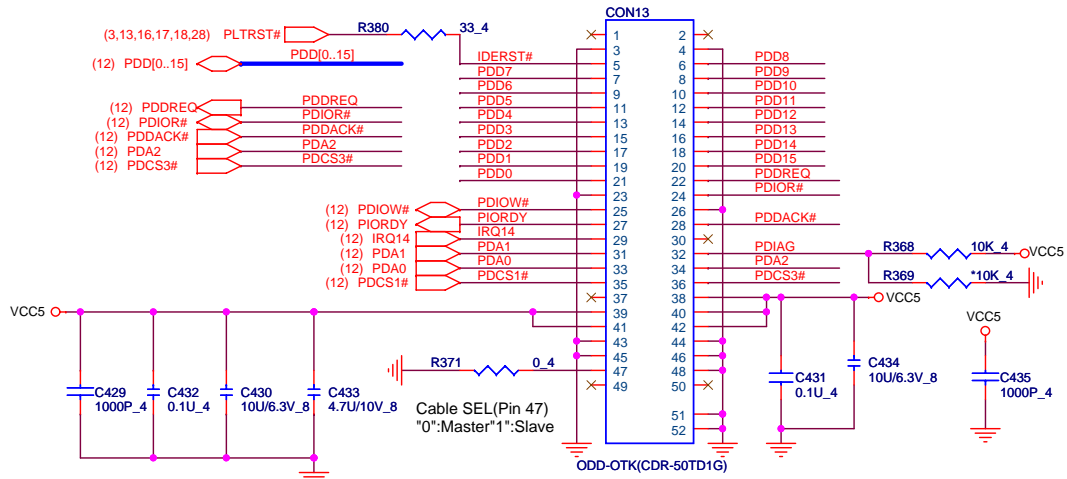

0618 Eric_add ESD diode for ODD ESD issue

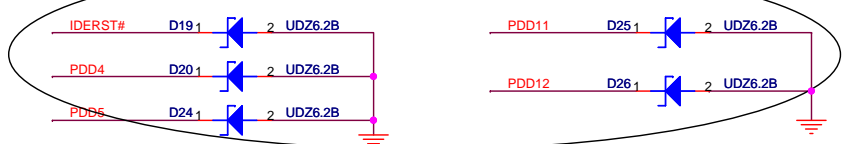

HDD CONNECTOR

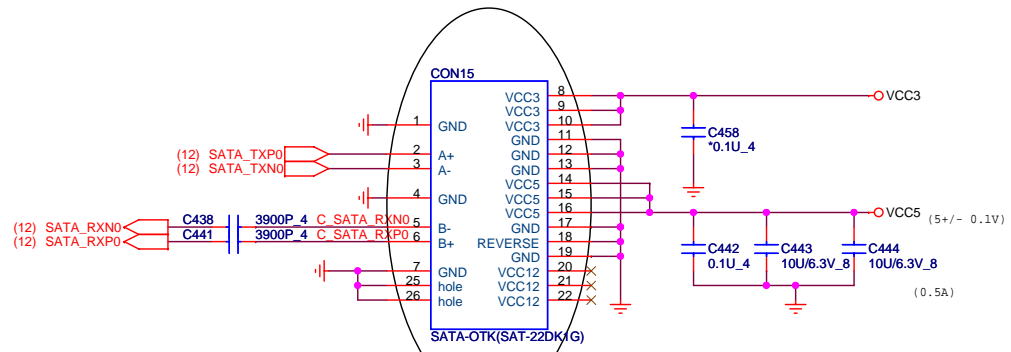

0611 Eric_modify HDD FP for SMT shift issue

TouchPAD Board CON(FPC)

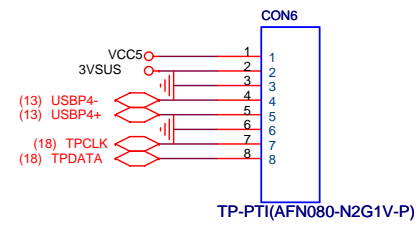

Button CON(FFC)

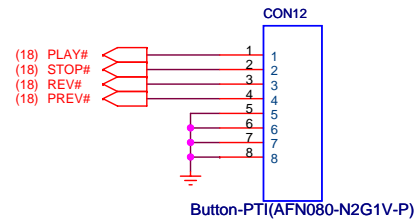

PSW Board CON(Inverse FFC)

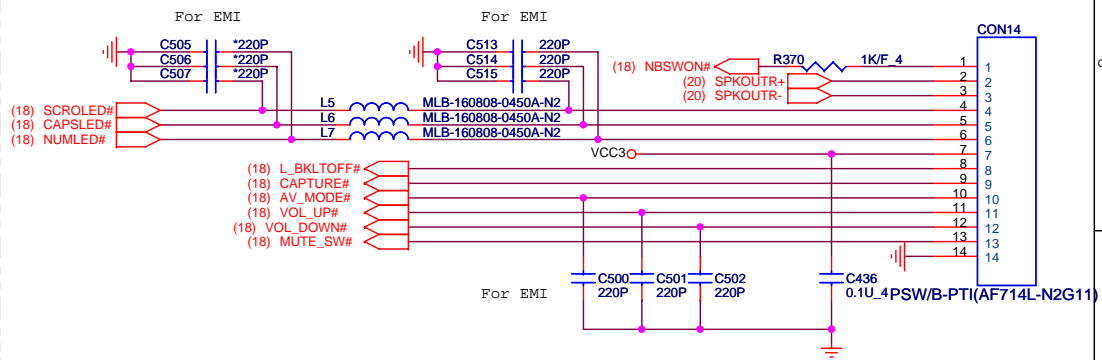

QUANTA COMPUTER

Title: **HDD/ODD/PSW/BUT/TP**

Size: B Document Number: **GD1B Main Board** Rev: 3A

Date: Monday, August 20, 2007 Sheet 21 of 35

1.Level 1 Environment-related Substances Should NEVER be Used.
 2.Purchase ink, paint, wire rods, and Molding resins only from the business Partners that Sony approves as Green Partners.

Keyboard

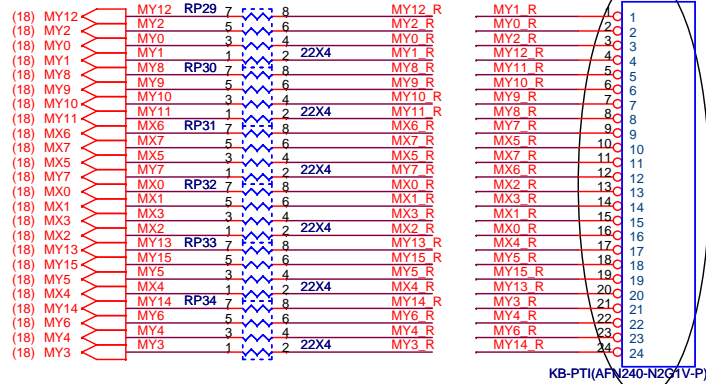
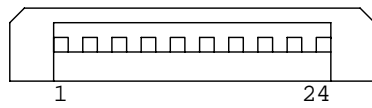

0711 Eric_modify FP for 2nd IR

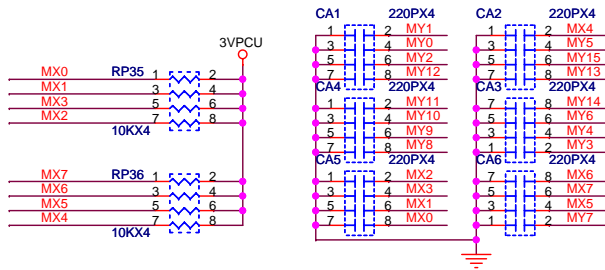
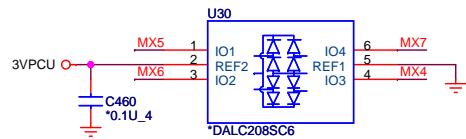
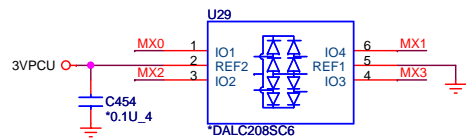

USB Port x 2

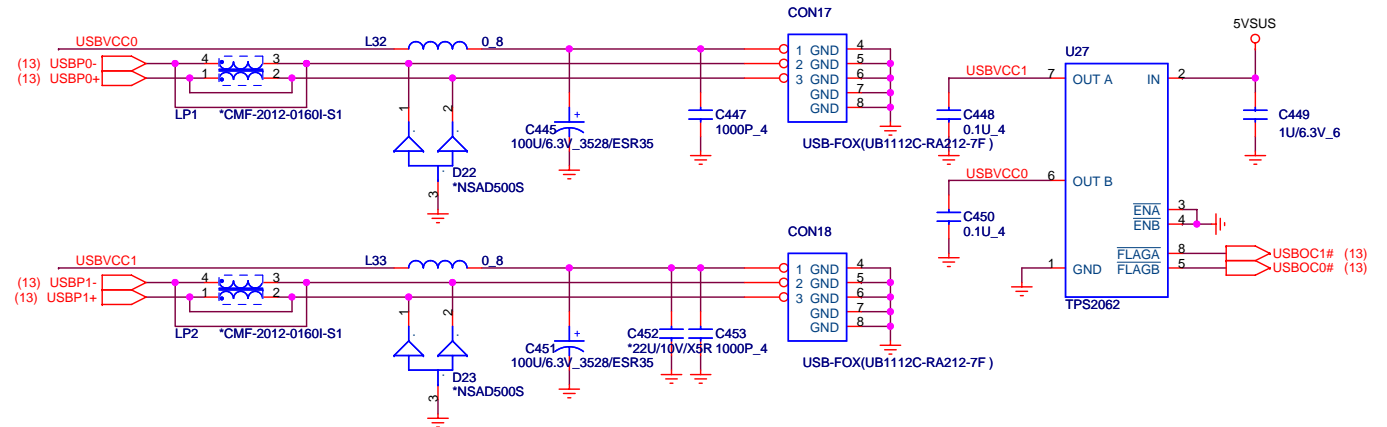

Felica

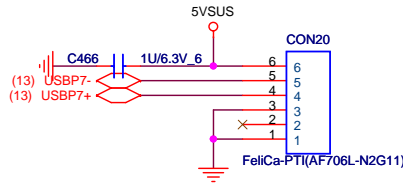

ODD

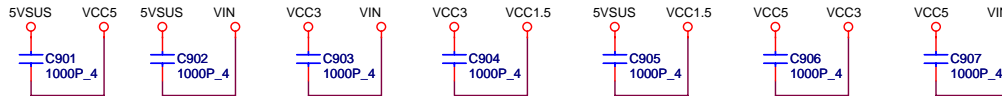

PCI Bus

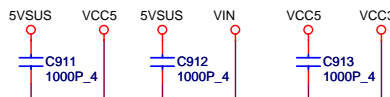

1.Level 1 Environment-related Substances Should NEVER be Used.
2.Purchase ink, paint, wire rods, and Molding resins only from the business Partners that Sony approves as Green Partners.

QUANTA COMPUTER

Title: **K/B ,USB Device**

Size: **B** Document Number: **GD1B Main Board** Rev: **3A**

Date: **Monday, August 20, 2007** Sheet: **22** of **35**

P19	D3/CAD0	MS_CD#	A8	MS_CD#	MS_CD# (16)
N18	D4/CAD1	MS_BS/SD_CMD/xD_WE#	E8	MS_BS	MS_BS (16)
N17	D11/CAD2	MS_CLK/SD_CLK/xD_ELPW#	A7	MS_CLK	MS_CLK (16)
M15	D5/CAD3	MS_SDIO/SD_DAT0/xD_D0	B7	MS_SDIO	MS_SDIO (16)
N19	D12/CAD4	MS_DATA1/SD_DAT1/xD_D1	C7	MS_DATA1	MS_DATA1 (16)
M18	D6/CAD5	MS_DATA2/SD_DAT2/xD_D2	A6	MS_DATA2	MS_DATA2 (16)
M17	D13/CAD6	MS_DATA3/SD_DAT3/xD_D3	B6	MS_DATA3	MS_DATA3 (16)
L19	D7/CAD7				
L18	D15/CAD8	SD_CD#	E9	SD_CD#	
L15	A10/CAD9	SD_CLK/xD_RE#	A4	SD_CLK	
K18	CE2#/CAD10	SD_CMD/xD_ALE#	C5	SD_CMD	
K17	QE#/CAD11	SD_DAT0/xD_D4	C6	SD_DATA0	
K15	A11/CAD12	SD_DAT1/xD_D5	A5	SD_DATA1	
J18	IORD#/CAD13	SD_DAT2/xD_D6	B5	SD_DATA2	
J15	A9/CAD14	SD_DAT3/xD_D7	E6	SD_DATA3	
J17	IOWR#/CAD15	SD_WP#	E7	SD_WP#	
H19	A17/CAD16				
F15	A24/CAD17	SM_CD#	B8	SM_CD#	
E17	A7/CAD18	xD_CLE	B4	xD_CLE	
D19	A25/CAD19				
A16	A6/CAD20	xD_CD#/xD_PHYS_WP#	A3	xD_CD#	
F14	A5/CAD21				
B15	A4/CAD22	SC_CD#	E3	SC_CD#	
B14	A3/CAD23	SC_CLK	E2	SC_CLK	
A14	A2/CAD24	SC_DATA	E1	SC_DATA	
C13	A1/CAD25	SC_FCB	E3	SC_FCB	
B13	A0/CAD26	SC_OC#	G5	SC_OC#	
C11	D0/CAD27	SC_PWR_CTRL	D1	SC_PWR_CTRL	
F11	D8/CAD28	SC_RFU	F5	SC_RFU	
F11	D1/CAD29	SC_RST	F5	SC_RST	
A10	D9/CAD30	SC_VCC_5V	G6	SC_VCC_5V	
C10	D10/CAD31				
L17	CE1#/CCBE0#	MC_PWR_CTRL_0	C8	MC_PWR_MS	
H18	A8/CCBE1#	MC_PWR_CTRL_1	F8	MC_PWR_SD	
E18	A12/CCBE2#				
E13	REG#/CCBE3#				
F18	A16/CLK	MS/SD:	D2	MS/SD:	
A11	WP/CLKRUN#	High Active PWR CTL	D3	High Active PWR CTL	
C15	RESET/CRST#		D17		
H14	A13/CPAR		D18		
E19	A23/CFRAME#		E5		
F17	A15/CRDY#		N14		
G15	A22/CTRDY#		P18		
G18	A20/CSTOP#		T3		
F19	A21/CDEVELSEL#		T17		
C14	CREQ/INPACK#		U1		
G17	WE#/CGNT#		U2		
G19	A14/CPERR#		U3		
C12	WAIT#/CSERR#		U4		
E12	READY/CINT#		U12		
A12	BVD1/STSCHG#		U16		
B12	BVD2/CAUDIO		U17		
H15	A19/CBLOCK#		U18		
			V1		
			V2		
			V3		
			V4		
N15	CD1#/CCD1#		V12		
B11	CD2#/CCD2#		V17		
A13	VS1#/CVS1		V18		
B16	VS2#/CVS2		V19		
B10	D2		W2		
M19	D14		W3		
H17	A18		W12		
			W18		

PCI8402

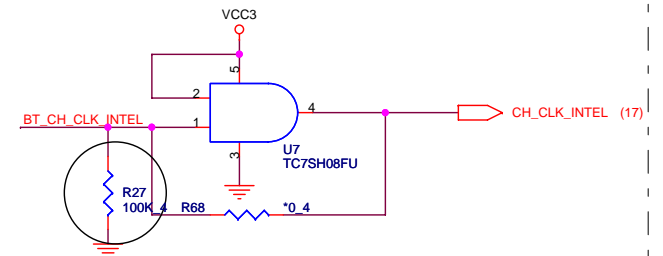
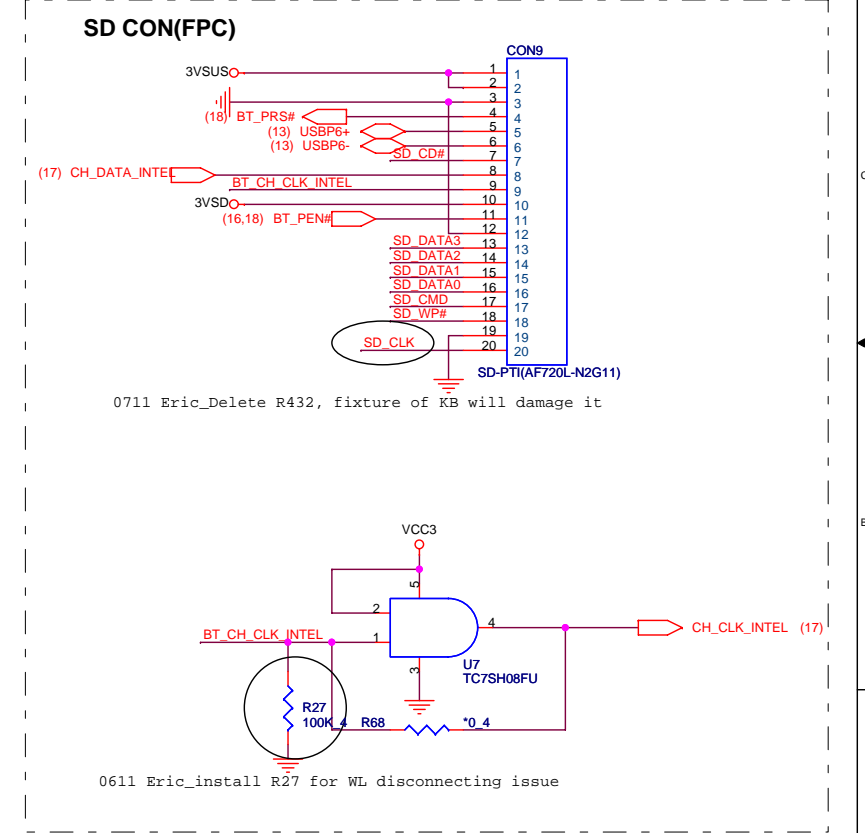
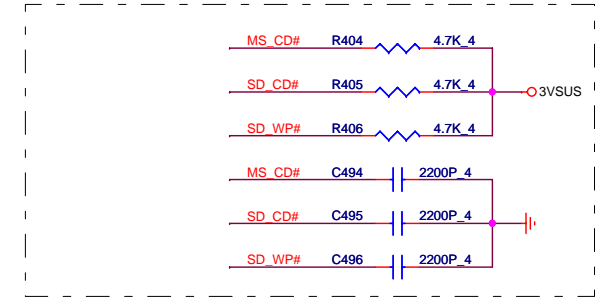
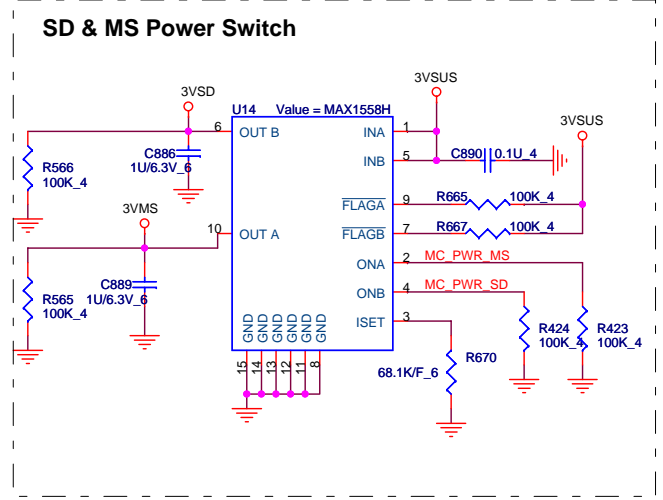

QUANTA COMPUTER

Title: **TI-8402 MS & SD**

Size B Document Number: **GD1B Main Board** Rev 3A

Date: Monday, August 20, 2007 Sheet 24 of 35

1.Level 1 Environment-related Substances Should NEVER be Used.
 2.Purchase ink, paint, wire rods, and Molding resins only from the business Partners that Sony approves as Green Partners.

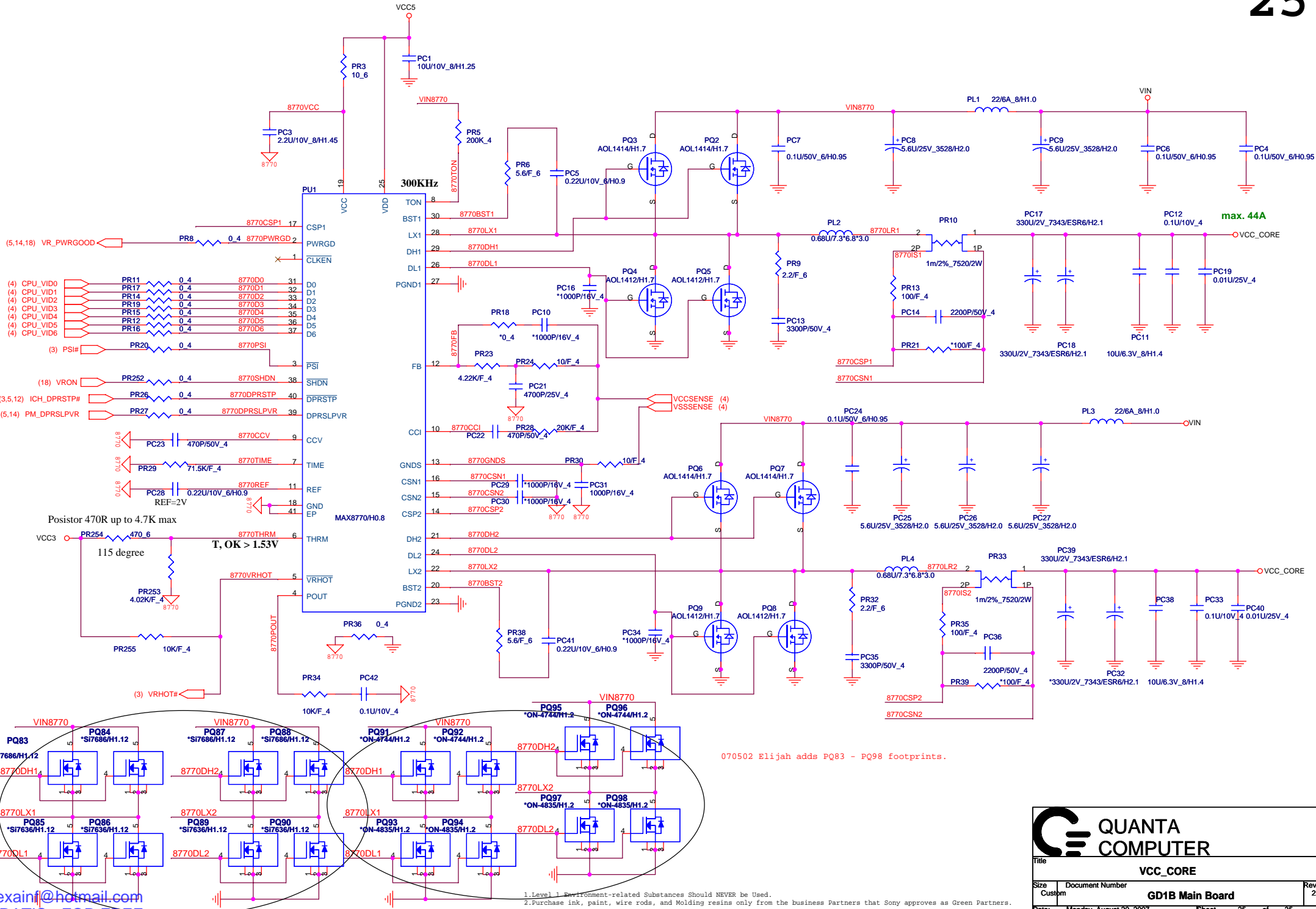

- (5,14,18) VR_PWRGOOD \leftarrow PR8 0.4 8770PWRGD 2
- (4) CPU_VID0 \leftarrow PR11 0.4 8770D0 31
- (4) CPU_VID1 \leftarrow PR17 0.4 8770D1 32
- (4) CPU_VID2 \leftarrow PR14 0.4 8770D2 33
- (4) CPU_VID3 \leftarrow PR19 0.4 8770D3 34
- (4) CPU_VID4 \leftarrow PR15 0.4 8770D4 35
- (4) CPU_VID5 \leftarrow PR12 0.4 8770D5 36
- (4) CPU_VID6 \leftarrow PR16 0.4 8770D6 37
- (3) PSi# \leftarrow PR20 0.4 8770PSI 3
- (18) VRON \leftarrow PR252 0.4 8770SHDN 38
- (3,5,12) ICH_DPRSTP# \leftarrow PR26 0.4 8770DPRSTP 40
- (5,14) PM_DPRSLPVR \leftarrow PR27 0.4 8770DPRSLPVR 39

- PC23 470P/50V_4 8770CCV 9
- PR29 71.5K/F_4 8770TIME 7
- PC28 0.22U/10V_6/H0.9 8770REF 11
- REF=2V
- PC22 470P/50V_4 8770 18
- GND EP 41
- PR254 470.6 8770THRM 6
- VCC3 115 degree
- PR253 4.02K/F_4 8770 4
- VRHOT 5
- PR255 10K/F_4 8770 4
- VRHOT# \leftarrow PR34 10K/F_4 8770 4

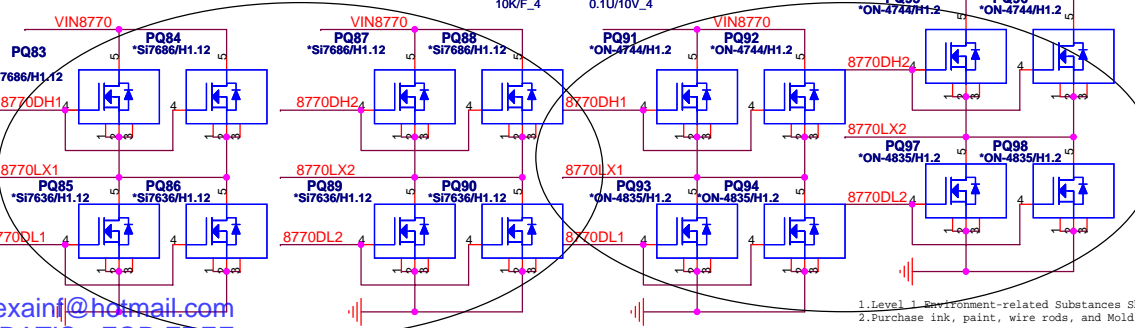

070502 Elijah adds PQ83 - PQ98 footprints.

hexainf@hotmail.com
GRATIS FOR FREE

1. Level 1 Environment-related Substances should NEVER be Used.
2. Purchase ink, paint, wire rods, and Molding resins only from the business Partners that Sony approves as Green Partners.

QUANTA COMPUTER

Title: **VCC_CORE**

Size: Custom	Document Number: GD1B Main Board	Rev: 2A
Date: Monday, August 20, 2007	Sheet: 25	of 35

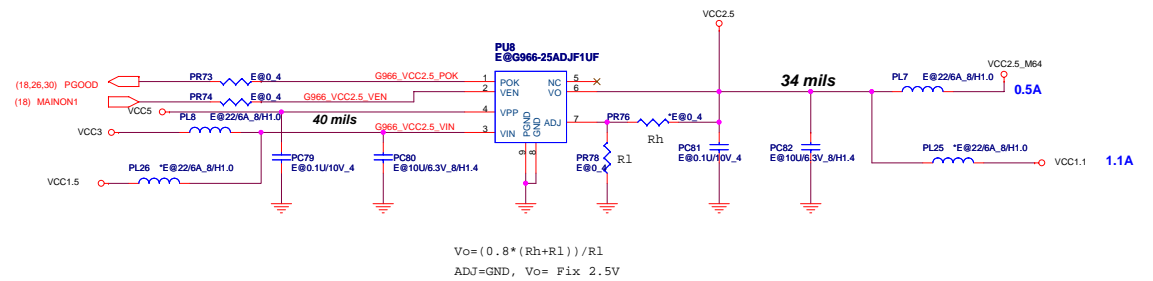
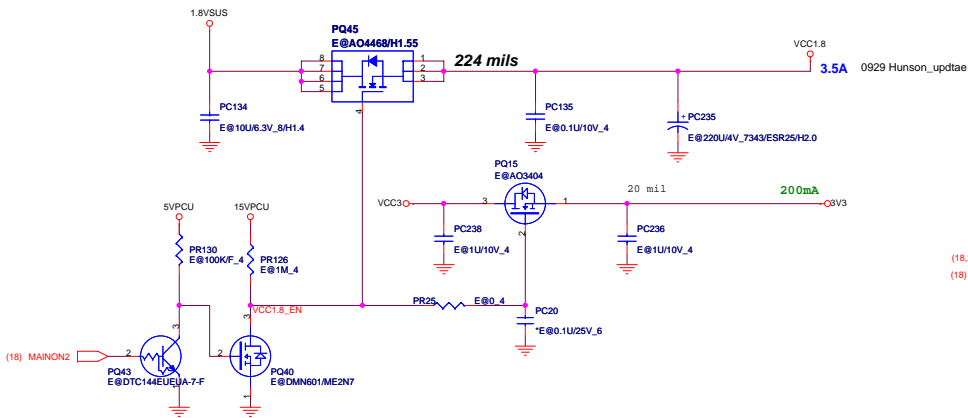
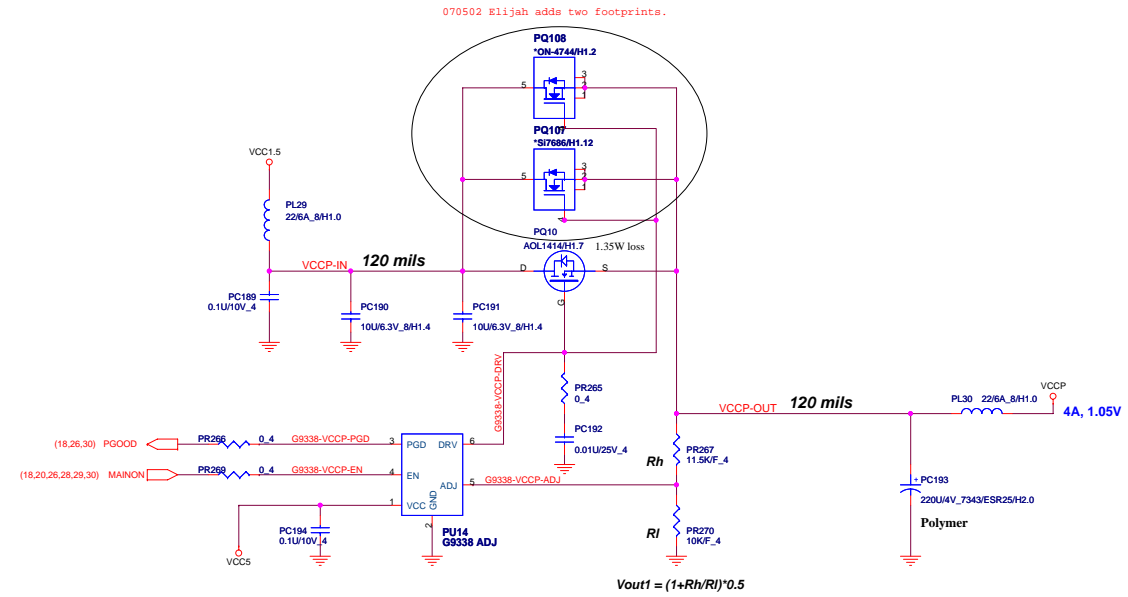
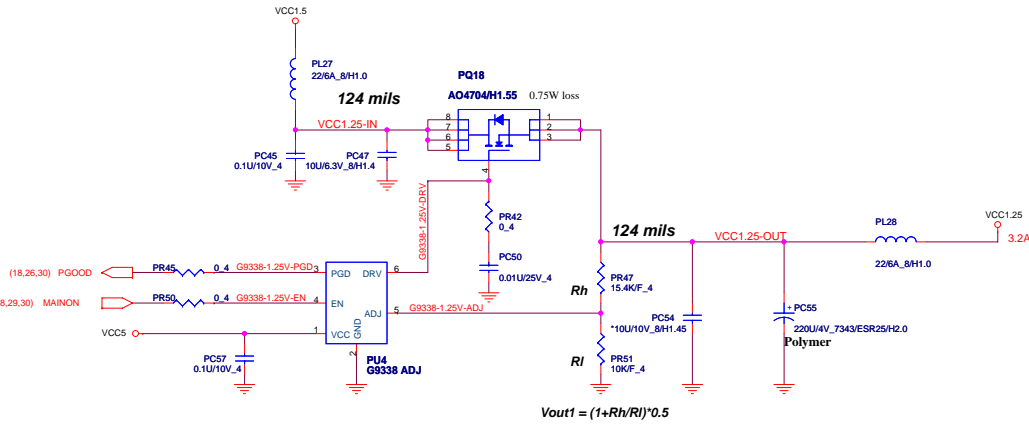

QUANTA COMPUTER

File: **VCC1.25, VCCP, VCC2.5, VCC1.8 & 3V3**

Size: Document Number: **GD1B Main Board** Rev: 2A

Date: Monday, August 20, 2007 Sheet: 27 of 35

1. Level 1 Environment-related Substances Should NEVER be Used.
 2. Purchase ink, paint, wire rods, and Molding resins only from the business Partners that Sony approves as Green Partners.

070125Sun_Adjust pin assignment

070125Sun_Adjust pin assignment

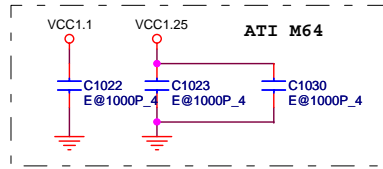
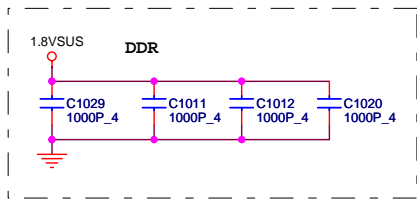
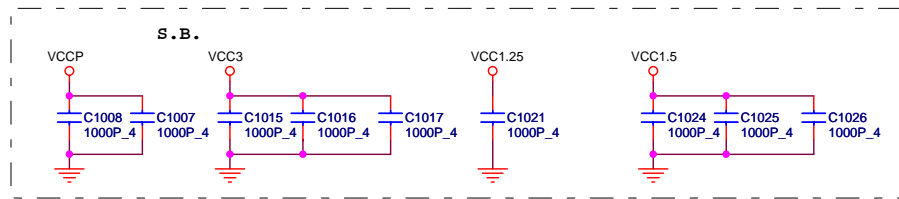
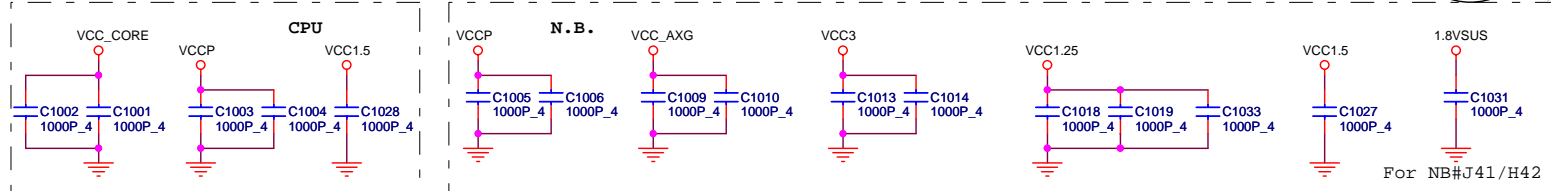
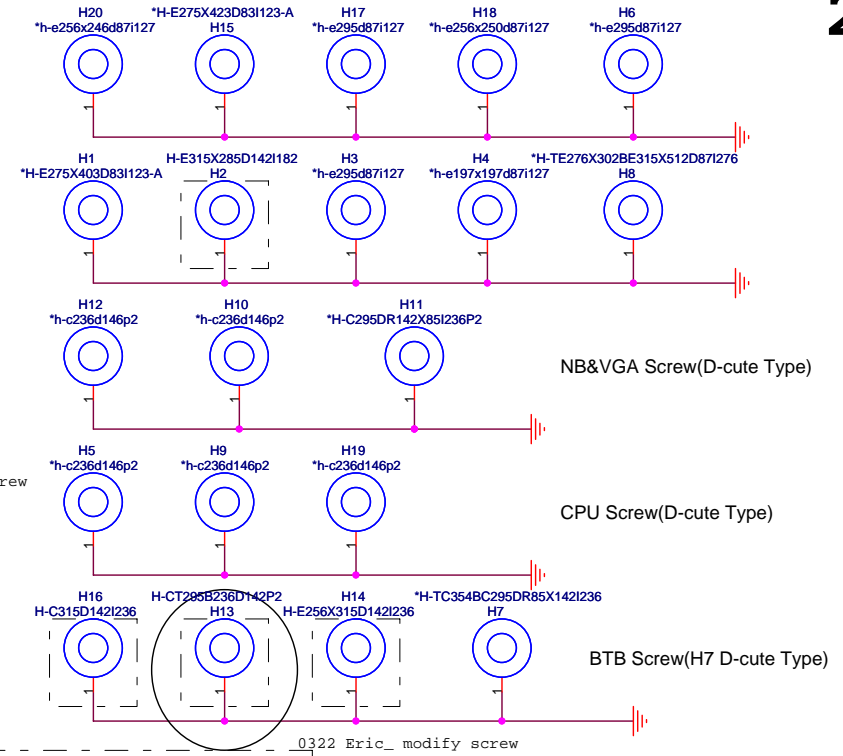
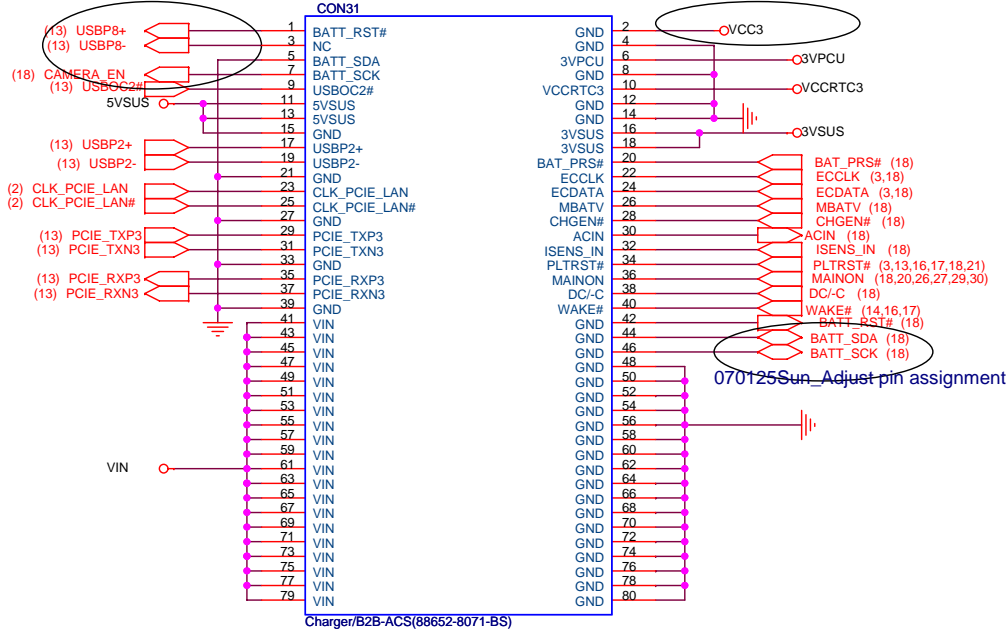

1.Level 1 Environment-related Substances Should NEVER be Used.
 2.Purchase ink, paint, wire rods, and Molding resins only from the business Partners that Sony approves as Green Partners.

QUANTA COMPUTER

Title: **Power Charger & LAN CON**

Size B: Document Number **GD1A Main Board** Rev 2A

Date: Tuesday, September 04, 2007 Sheet 28 of 35

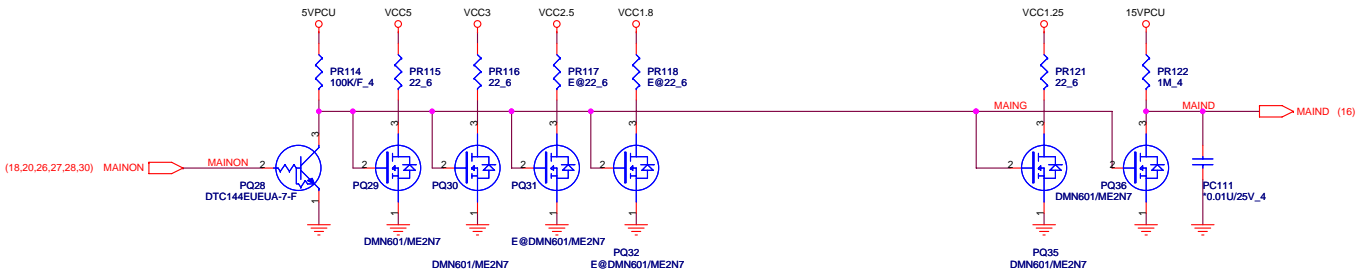
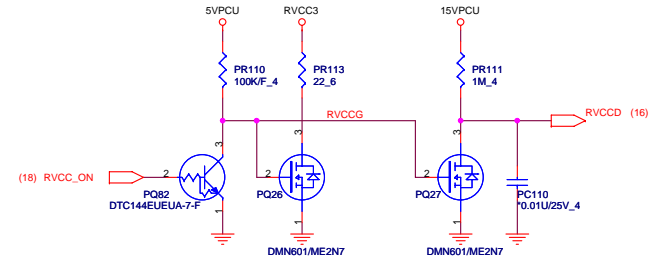
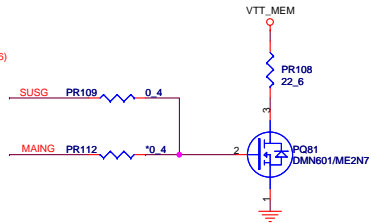
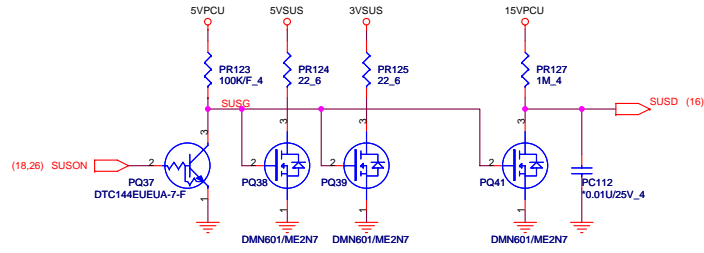

1.Level 1 Environment-related Substances Should NEVER be Used.
 2.Purchase Ink, paint, wire rods, and Molding resins only from the business Partners that Sony approves as Green Partners.

QUANTA COMPUTER	
Title Discharge, SUSG, RVCCD, MAIND	
Size Custom	Document Number GD1A Main Board
Date: Tuesday, September 04, 2007	Sheet 29 of 35
	Rev 2A

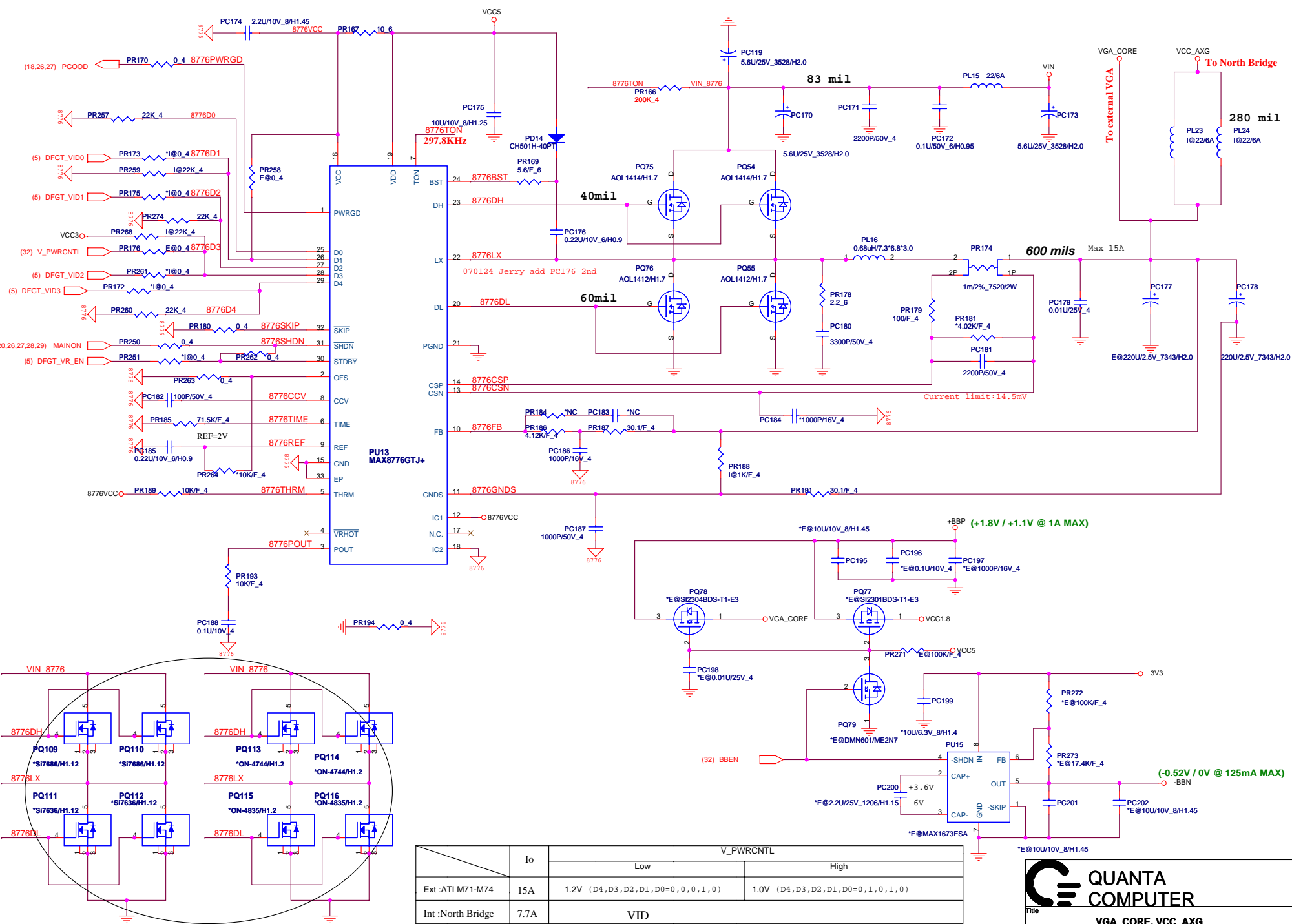

	Io	V_PWRCNTL	
		Low	High
Ext :ATI M71-M74	15A	1.2V (D4,D3,D2,D1,D0=0,0,0,1,0)	1.0V (D4,D3,D2,D1,D0=0,1,0,1,0)
Int :North Bridge	7.7A	VID	

QUANTA COMPUTER

Title: **VGA_CORE, VCC_AKG**

Size: Document Number: **GD1B Main Board** Rev 2A

Date: Monday, August 20, 2007 Sheet 30 of 35

070502 Elijah adds PQ109 - PQ116 footprints.

1.Level 1 Environment-related Substances Should NEVER be Used.
 2.Purchase ink, paint, wire rods, and Molding resins only from the business Partners that Sony approves as Green Partners.

U3001A PART 1 OF 7

GFX_TXP0	AK33	PCIE_RX0P	PCIE_TX0P	AG31	C GFX_RXP0	C3000	E@0.1U_4	GFX_RXP0	E@0.1U_4	GFX_RXN0
GFX_TXN0	AJ33	PCIE_RX0N	PCIE_TX0N	AG30	C GFX_RXN0	C3001	E@0.1U_4	GFX_RXN0	E@0.1U_4	GFX_RXN0
GFX_TXP1	AJ35	PCIE_RX1P	PCIE_TX1P	AF31	C GFX_RXP1	C3002	E@0.1U_4	GFX_RXP1	E@0.1U_4	GFX_RXN1
GFX_TXN1	AJ34	PCIE_RX1N	PCIE_TX1N	AF30	C GFX_RXN1	C3003	E@0.1U_4	GFX_RXN1	E@0.1U_4	GFX_RXN1
GFX_TXP2	AH35	PCIE_RX2P	PCIE_TX2P	AF28	C GFX_RXP2	C3004	E@0.1U_4	GFX_RXP2	E@0.1U_4	GFX_RXN2
GFX_TXN2	AH34	PCIE_RX2N	PCIE_TX2N	AF27	C GFX_RXN2	C3005	E@0.1U_4	GFX_RXN2	E@0.1U_4	GFX_RXN2
GFX_TXP3	AG35	PCIE_RX3P	PCIE_TX3P	AD31	C GFX_RXP3	C3006	E@0.1U_4	GFX_RXP3	E@0.1U_4	GFX_RXN3
GFX_TXN3	AG34	PCIE_RX3N	PCIE_TX3N	AD30	C GFX_RXN3	C3007	E@0.1U_4	GFX_RXN3	E@0.1U_4	GFX_RXN3
GFX_TXP4	AF33	PCIE_RX4P	PCIE_TX4P	AD28	C GFX_RXP4	C3008	E@0.1U_4	GFX_RXP4	E@0.1U_4	GFX_RXN4
GFX_TXN4	AE33	PCIE_RX4N	PCIE_TX4N	AD27	C GFX_RXN4	C3009	E@0.1U_4	GFX_RXN4	E@0.1U_4	GFX_RXN4
GFX_TXP5	AE35	PCIE_RX5P	PCIE_TX5P	AB31	C GFX_RXP5	C3010	E@0.1U_4	GFX_RXP5	E@0.1U_4	GFX_RXN5
GFX_TXN5	AE34	PCIE_RX5N	PCIE_TX5N	AB30	C GFX_RXN5	C3011	E@0.1U_4	GFX_RXN5	E@0.1U_4	GFX_RXN5
GFX_TXP6	AD35	PCIE_RX6P	PCIE_TX6P	AB28	C GFX_RXP6	C3012	E@0.1U_4	GFX_RXP6	E@0.1U_4	GFX_RXN6
GFX_TXN6	AD34	PCIE_RX6N	PCIE_TX6N	AB27	C GFX_RXN6	C3013	E@0.1U_4	GFX_RXN6	E@0.1U_4	GFX_RXN6
GFX_TXP7	AC35	PCIE_RX7P	PCIE_TX7P	AA31	C GFX_RXP7	C3014	E@0.1U_4	GFX_RXP7	E@0.1U_4	GFX_RXN7
GFX_TXN7	AC34	PCIE_RX7N	PCIE_TX7N	AA30	C GFX_RXN7	C3015	E@0.1U_4	GFX_RXN7	E@0.1U_4	GFX_RXN7
GFX_TXP8	AB33	PCIE_RX8P	PCIE_TX8P	AA28	C GFX_RXP8	C3016	E@0.1U_4	GFX_RXP8	E@0.1U_4	GFX_RXN8
GFX_TXN8	AA33	PCIE_RX8N	PCIE_TX8N	AA27	C GFX_RXN8	C3017	E@0.1U_4	GFX_RXN8	E@0.1U_4	GFX_RXN8
GFX_TXP9	AA35	PCIE_RX9P	PCIE_TX9P	W31	C GFX_RXP9	C3018	E@0.1U_4	GFX_RXP9	E@0.1U_4	GFX_RXN9
GFX_TXN9	AA34	PCIE_RX9N	PCIE_TX9N	W30	C GFX_RXN9	C3019	E@0.1U_4	GFX_RXN9	E@0.1U_4	GFX_RXN9
GFX_TXP10	Y35	PCIE_RX10P	PCIE_TX10P	W28	C GFX_RXP10	C3020	E@0.1U_4	GFX_RXP10	E@0.1U_4	GFX_RXN10
GFX_TXN10	Y34	PCIE_RX10N	PCIE_TX10N	W27	C GFX_RXN10	C3021	E@0.1U_4	GFX_RXN10	E@0.1U_4	GFX_RXN10
GFX_TXP11	W35	PCIE_RX11P	PCIE_TX11P	V31	C GFX_RXP11	C3022	E@0.1U_4	GFX_RXP11	E@0.1U_4	GFX_RXN11
GFX_TXN11	W34	PCIE_RX11N	PCIE_TX11N	V30	C GFX_RXN11	C3023	E@0.1U_4	GFX_RXN11	E@0.1U_4	GFX_RXN11
GFX_TXP12	V33	PCIE_RX12P	PCIE_TX12P	V28	C GFX_RXP12	C3024	E@0.1U_4	GFX_RXP12	E@0.1U_4	GFX_RXN12
GFX_TXN12	U33	PCIE_RX12N	PCIE_TX12N	V27	C GFX_RXN12	C3025	E@0.1U_4	GFX_RXN12	E@0.1U_4	GFX_RXN12
GFX_TXP13	U35	PCIE_RX13P	PCIE_TX13P	U31	C GFX_RXP13	C3026	E@0.1U_4	GFX_RXP13	E@0.1U_4	GFX_RXN13
GFX_TXN13	U34	PCIE_RX13N	PCIE_TX13N	U30	C GFX_RXN13	C3027	E@0.1U_4	GFX_RXN13	E@0.1U_4	GFX_RXN13
GFX_TXP14	T35	PCIE_RX14P	PCIE_TX14P	U28	C GFX_RXP14	C3028	E@0.1U_4	GFX_RXP14	E@0.1U_4	GFX_RXN14
GFX_TXN14	T34	PCIE_RX14N	PCIE_TX14N	U27	C GFX_RXN14	C3029	E@0.1U_4	GFX_RXN14	E@0.1U_4	GFX_RXN14
GFX_TXP15	R35	PCIE_RX15P	PCIE_TX15P	R31	C GFX_RXP15	C3030	E@0.1U_4	GFX_RXP15	E@0.1U_4	GFX_RXN15
GFX_TXN15	R34	PCIE_RX15N	PCIE_TX15N	R30	C GFX_RXN15	C3031	E@0.1U_4	GFX_RXN15	E@0.1U_4	GFX_RXN15

PCI - EXPRESS INTERFACE

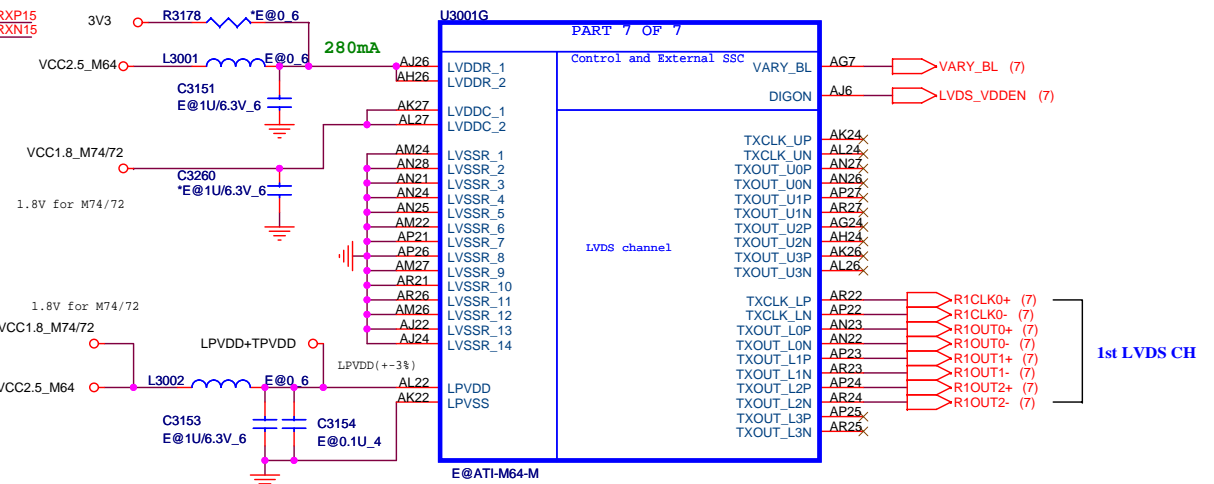
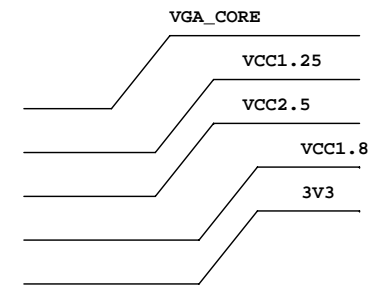
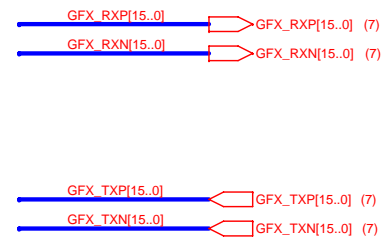
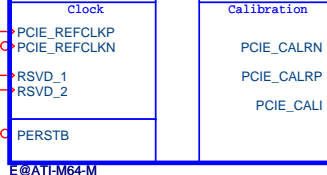
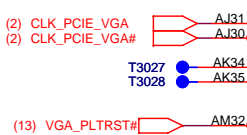

1st LVDS CH

QUANTA COMPUTER

Title: **ATI M64M PCIE**

Size B | Document Number: **GD1B Main Board** | Rev 2A

Date: Monday, August 20, 2007 | Sheet 31 of 35

1.Level 1 Environment-related Substances Should NEVER be Used.
 2.Purchase ink, paint, wire rods, and Molding resins only from the business Partners that Sony approves as Green Partners.

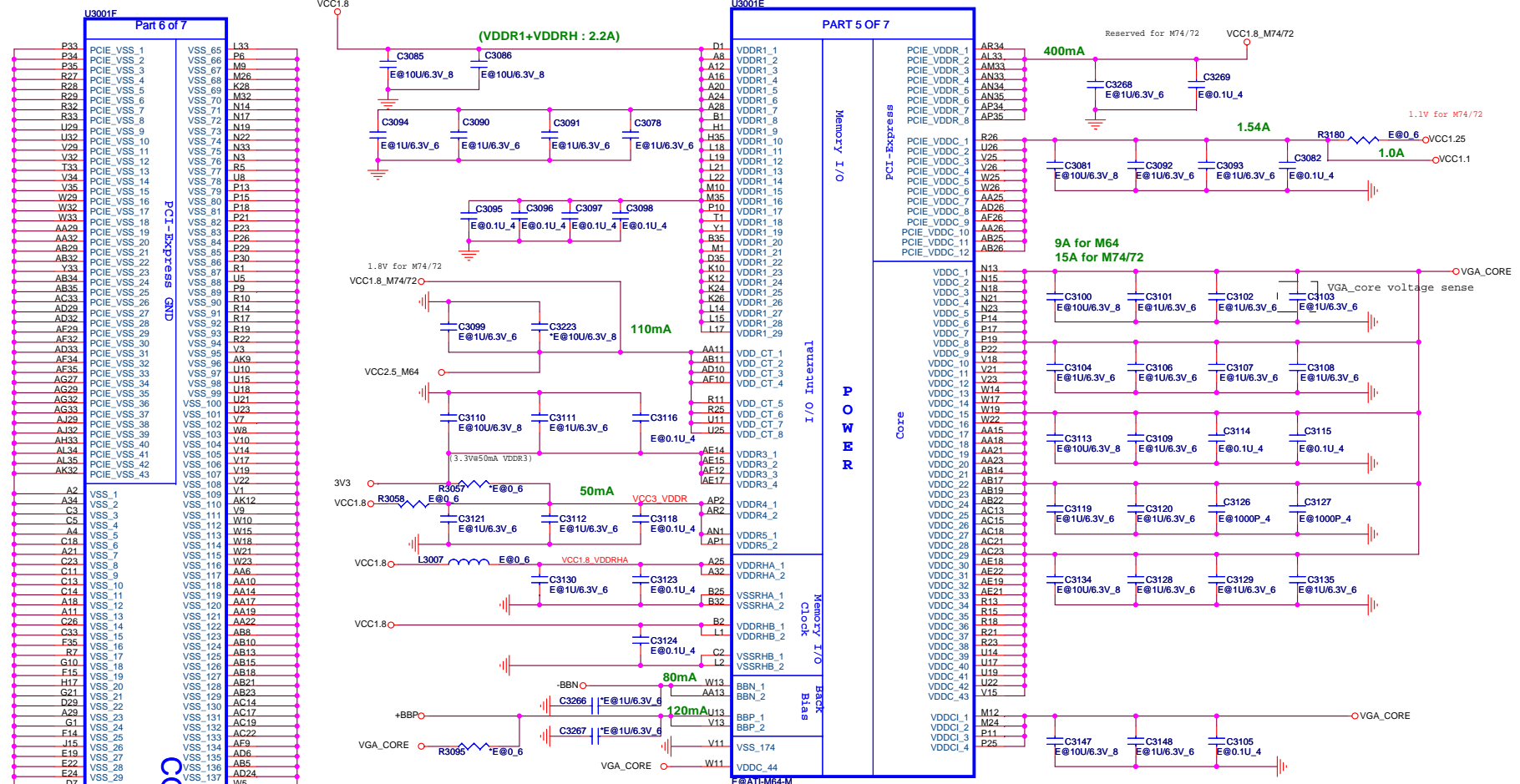

CORE GND

POWER Regulator	M64/M71	Ra11	M72/M74	Ra11
VDDC+VDDCI	1.0-1.2V	VGA_CORE	0.95-1.1V	VGA_CORE
PCIE_PVDD	1.25	VCC1.25	1.8	VCC1.8_M74/72
PCIE_VDDR	NC	x	1.8	VCC1.8_M74/72
PCIE_VDDC	1.25	VCC1.25	1.1	VCC1.1
MPVDD	VDDC	VGA_CORE	VDDC	VGA_CORE
DPLL_PVDD	2.5	VCC2.5_M64	1.8	VCC1.8_M74/72
DPLL_VDDC	1.25	VCC1.25	1.1	VCC1.1
VDDR1+VDDRH	1.8	VCC1.8	1.8	VCC1.8
VDDR4+VDDR5	1.8	VCC1.8	1.8	VCC1.8
VDDR3	3.3	3V3	3.3	3V3
VDD_CT	2.5	VCC2.5_M64	1.8	VCC1.8_M74/72
LPVDD+TPVDD	2.5	VCC2.5_M64	1.8	VCC1.8_M74/72
LVDDR	2.5	VCC2.5_M64	3.3	3V3_M74/72
LVVDD	NC	x	1.8	VCC1.8_M74/72
TXVDDR	2.5	VCC2.5_M64	1.8	VCC1.8_M74/72
AVDD	2.5	VCC2.5_M64	1.8	VCC1.8_M74/72
VDD1DI+VDD2DI	2.5	VCC2.5_M64	1.8	VCC1.8_M74/72
A2VDD	2.5	VCC2.5_M64	3.3	3V3_M74/72
A2VDDQ	NC	x	1.8	VCC1.8_M74/72

1.Level 1 Environment-related Substances should NEVER be Used.
2.Purchase ink, paint, wire rods, and Molding resins only from the business Partners that Sony approves as Green Partners.

QUANTA COMPUTER

File: **ATI M64M POWER**

Size	Document Number	Rev
Custom	GD1B Main Board	2A
Date:	Monday, August 20, 2007	Sheet 33 of 35

Channel A

MEMORY INTERFACE A

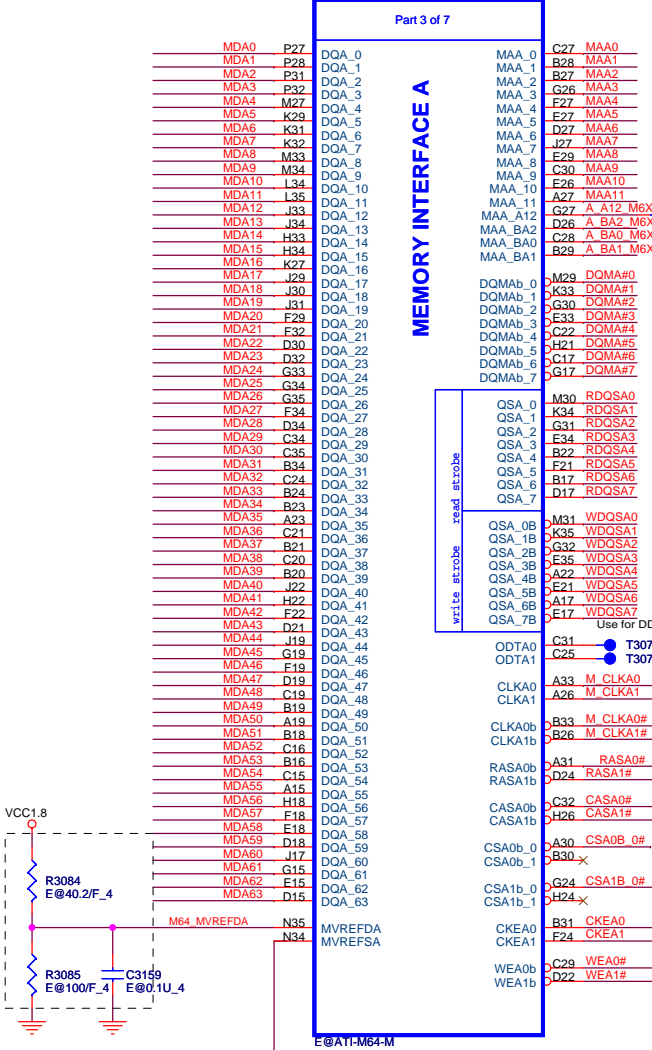

Channel B

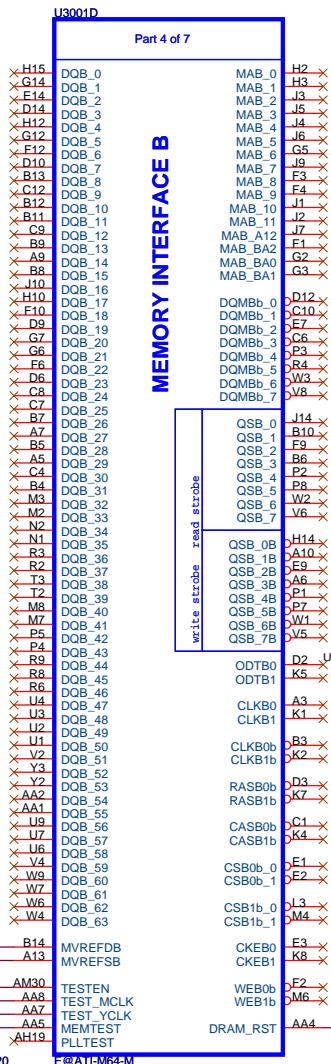

OPTION STRAPS

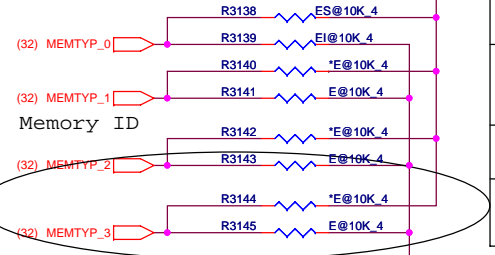
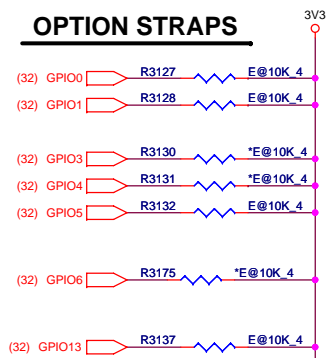

Gd1B: Add for new V-RAM

M64-M Strap

STRAPS	PIN	DESCRIPTION	ASIC DEFAULT
TX_PWRS_ENB	GPIO0	Transmitter Power Savings Enable 0: 50% Tx output swing 1: full Tx output swing	0 (internal pull-down)
TX_DEEMPH_EN	GPIO1	(recommended) Transmitter De-emphasis Enable 0: Tx de-emphasis disabled 1: Tx de-emphasis enabled (recommended)	0 (internal pull-down)
Reserved	GPIO(3:2)	ATI internal use only. Other logic must not affect this signal during RESET.(GPIO2=VDD_VCL)	00
DEBUG_ACCESS	GPIO4	Strap to set the debug muxes to bring out DEBUG signals even if registers are inaccessible	0 (internal pull-down)
PLL_IBIAS_RD	GPIO[6:5]	Bias Current for the PCI Express PHY PLL	01
Reserved	GPIO8	ATI internal use only. Other logic must not affect this signal during RESET.(Serial ROM Output from ROM)	0
ROMIDCFG(3:0)	GPIO(9,13:11)	If no ROM attached, controls chip IDIs. If rom attached identifies ROM type 000x - No ROM, MEM_AP_SIZE=00 128MB 001x - No ROM, MEM_AP_SIZE=01 256MB 010x - No ROM, MEM_AP_SIZE=10 64MB(Default) 011x - No ROM, MEM_AP_SIZE=11 Reserved 1000 - Parallel ROM, chip IDIs from ROM 1001 - Serial AT25F1024 ROM (Atmel), chip IDIs from ROM 1010 - Serial AT45DB011 ROM (Atmel), chip IDIs from ROM 1011 - Serial M25P10 ROM (ST), chip IDIs from ROM 1100 - Serial M25P05 ROM (ST), chip IDIs from ROM 1100 - Serial NX25F011B ROM (ISSI), chip IDIs from ROM	GPIO[9,13,12,11] 0000 (internal pull-down)
VIP_DEVICE	VSYNC	Indicates if any slave VIP host devices drove this pin low during reset. 0- Slave VIP host port device present. 1-No slave VIP port devices reporting presence during reset	0 (internal pull-down)
Reserved	PCIE_TEST	ATI internal use only. Other logic must not affect this signal during RESET.(Serial ROM Output from ROM)	0
Reserved	HSYNC	ATI internal use only. Other logic must not affect this signal during RESET.(Serial ROM Output from ROM)	0

VRAM Straps

REV. 0.1

STRAPS	PIN	DESCRIPTION	VALUE
MEMTYP[1:0]	GPIO 27,26	Memory identification for BIOS 00 - Infineon GDDR3 : 2M x 32 bits x 4 banks(Default) 01 - SAMSUNG GDDR3 : 2M x 32 bits x 4 banks 10 - RESERVED 11 - RESERVED	00

MEMTYP3	MEMTYP2	MEMTYP1	MEMTYP0	R3140	R3141	R3138	R3139	R3142	R3143	R3144	R3145	
0	0	0	0	NC	10K	NC	10K	NC	10K	NC	10K	000 - Infineon GDDR3 : 2M x 32 bits x 4 banks
0	0	0	1	NC	10K	10K	NC	NC	10K	NC	10K	001 - SAMSUNG GDDR3(G) : 2M x 32 bits x 4 banks
0	0	1	0	10K	NC	NC	10K	NC	10K	NC	10K	010 - Hynix GDDR3: 2M x 32 bits x 4 banks
0	0	1	1	10K	NC	10K	NC	NC	10K	NC	10K	011 - SAMSUNG GDDR3(I) : 2M x 32 bits x 4 banks
0	1	0	0	NC	10K	NC	10K	10K	NC	NC	10K	100 - Samsung GDDR3 : 16Mx32
0	1	0	1	NC	10K	10K	NC	NC	10K	NC	10K	101 - Hynix GDDR3 : 16Mx32
0	1	1	0	10K	NC	NC	10K	10K	NC	NC	10K	101 - Qimonda GDDR3 : 16Mx32
0	1	1	1	10K	NC	10K	NC	10K	NC	NC	10K	

ATI M64-M STRAP
Gd1B Main Board
Date: Tuesday, September 04, 2007 Sheet 35 of 35