

8101E Install
8111B NA

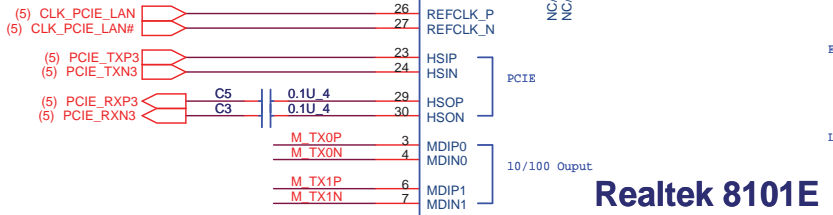

Realtek 8101E

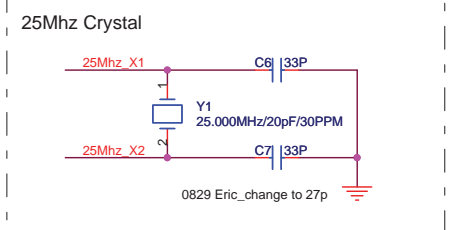
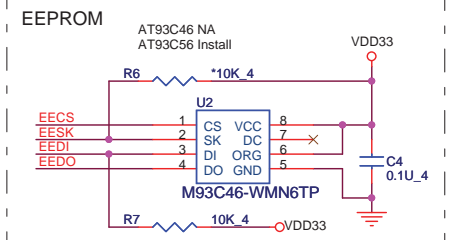
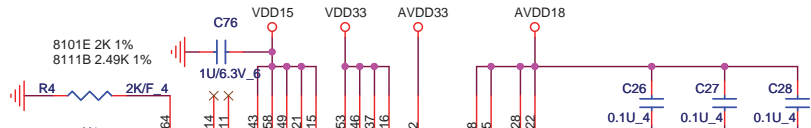
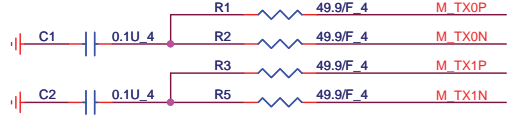
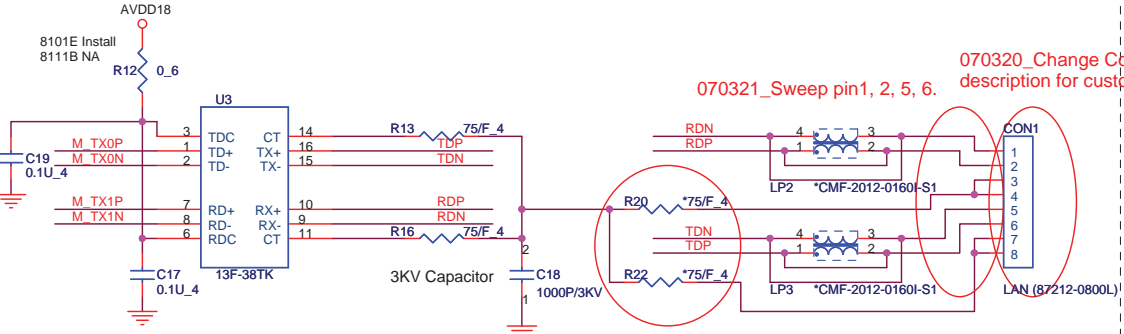
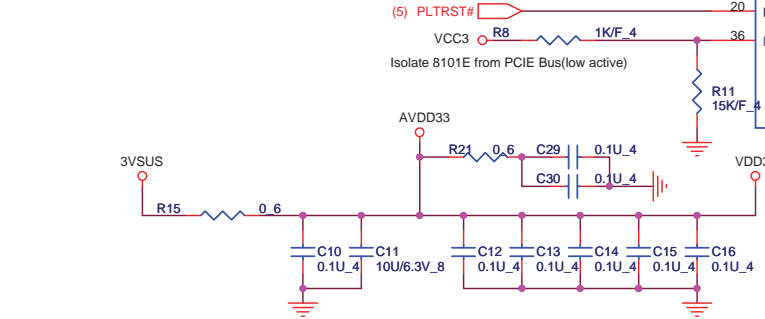

070321_Sweep pin1, 2, 5, 6.
070320_Change Cbn 1 P/N, foot print and description for customer's request

070320_Reserve space for R20 and R22

1. Level 1 Environment-related Substances Should NEVER be Used.
2. Purchase ink, paint, wire rods and molding resins only from the business partners that Sony approves as Green Partners.

USB CONN

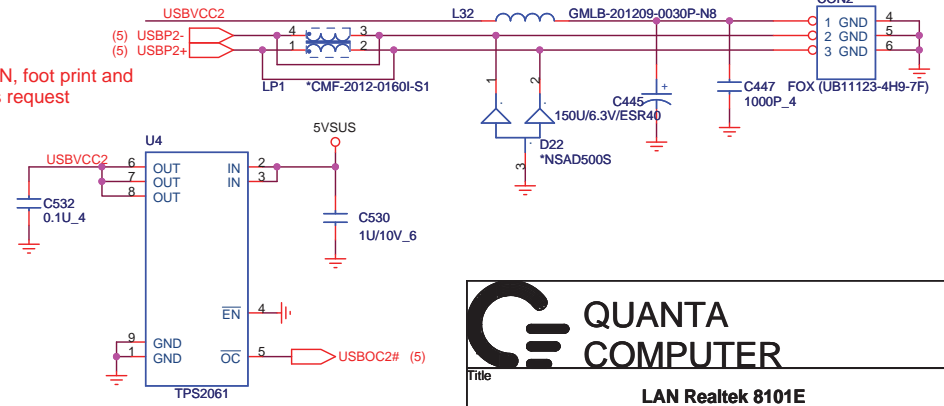

QUANTA COMPUTER

Title: LAN Realtek 8101E

Size B Document Number: GD1 Charger Board Rev 1A

Date: Wednesday, July 11, 2007 Sheet 1 of 4

DVT:
PVT:No change

MP:
a. CAMERA EMI:
Remove C461, C462 ; ADD L1, C467

<http://hobi-elektronika.net>

Title <Title>			
Size A	Document Number <Doc>		Rev <RevCode>
Date:	Wednesday, July 11, 2007	Sheet	1 of 1

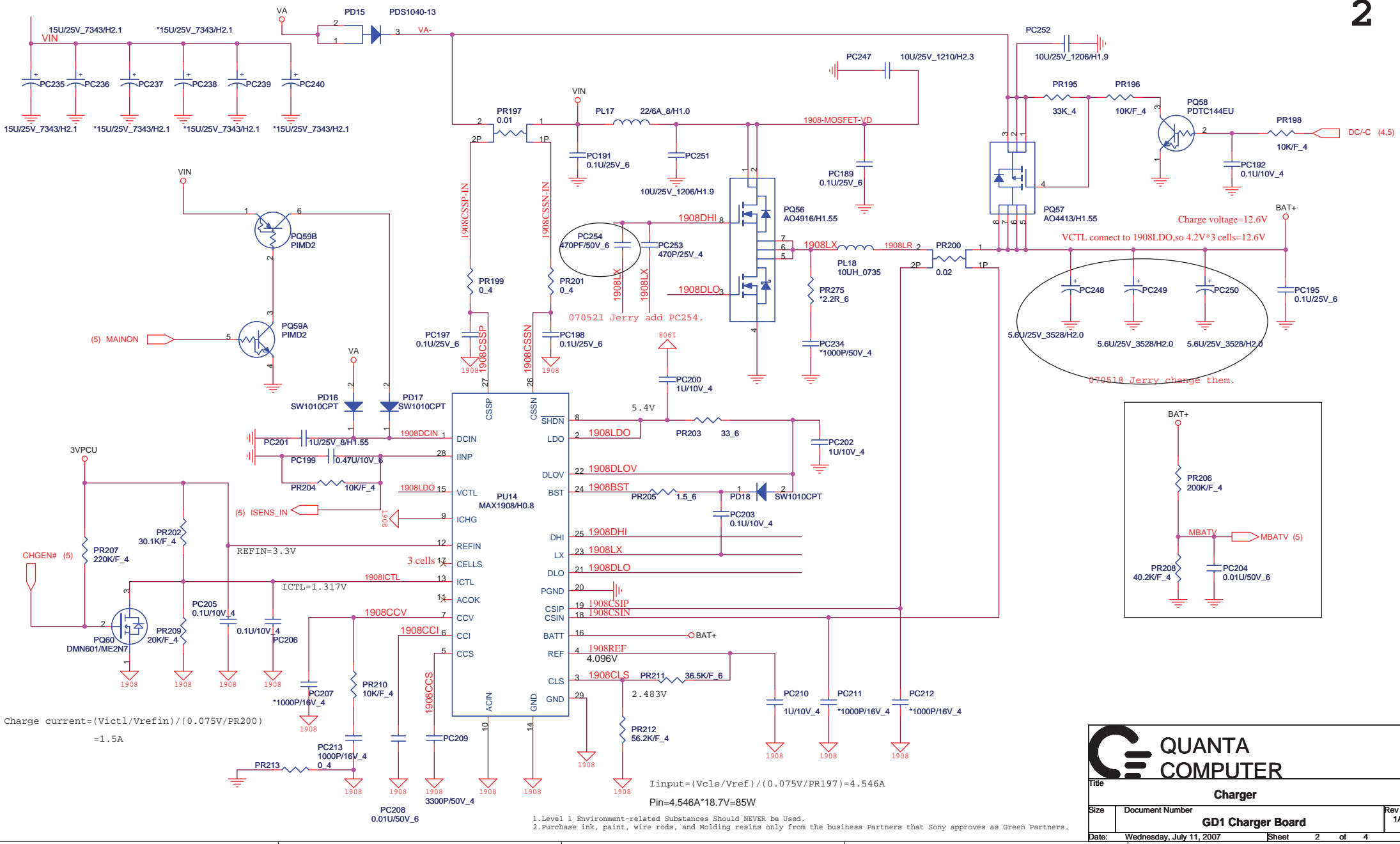

Charge current = $(V_{ictl} / V_{refin}) / (0.075V / PR200)$
 $= 1.5A$

$I_{input} = (V_{cls} / V_{ref}) / (0.075V / PR197) = 4.546A$
 $P_{in} = 4.546A * 18.7V = 85W$

1. Level 1 Environment-related Substances Should NEVER be Used.
2. Purchase ink, paint, wire rods, and Molding resins only from the business Partners that Sony approves as Green Partners.

QUANTA COMPUTER

Title: **Charger**

Size	Document Number	Rev
	GD1 Charger Board	1A

Date: Wednesday, July 11, 2007 Sheet 2 of 4

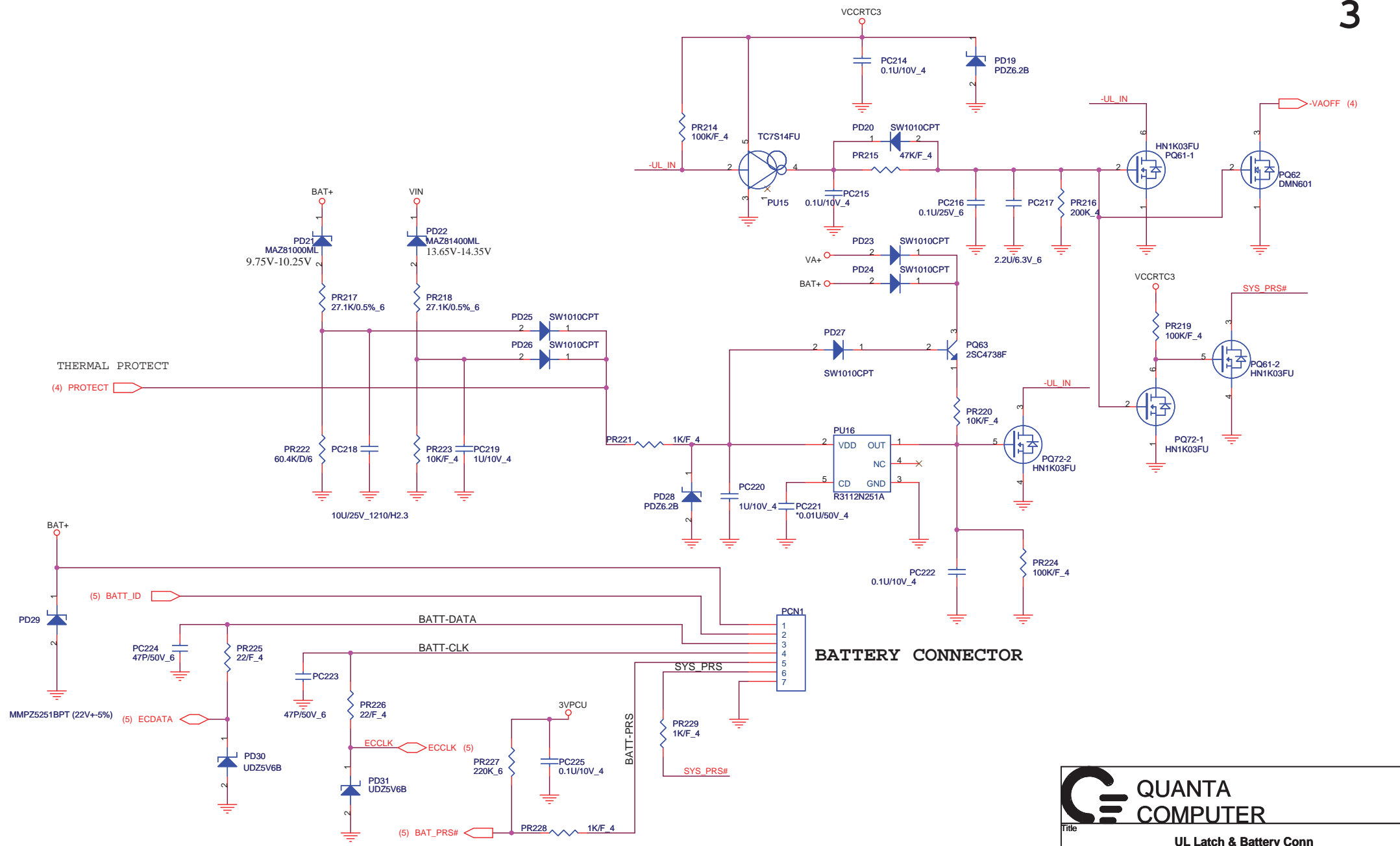

1.Level 1 Environment-related Substances Should NEVER be Used.
 2.Purchase ink, paint, wire rods, and Molding resins only from the business Partners that Sony approves as Green Partners.

 QUANTA COMPUTER			
			Title UL Latch & Battery Conn
Size B	Document Number GD1 Charger Board	Rev 1A	
Date: Wednesday, July 11, 2007		Sheet 3	of 4

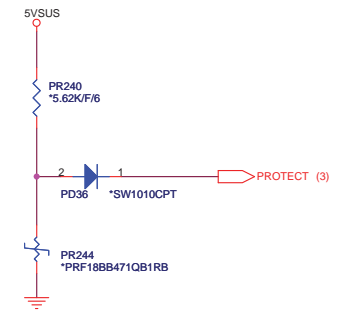
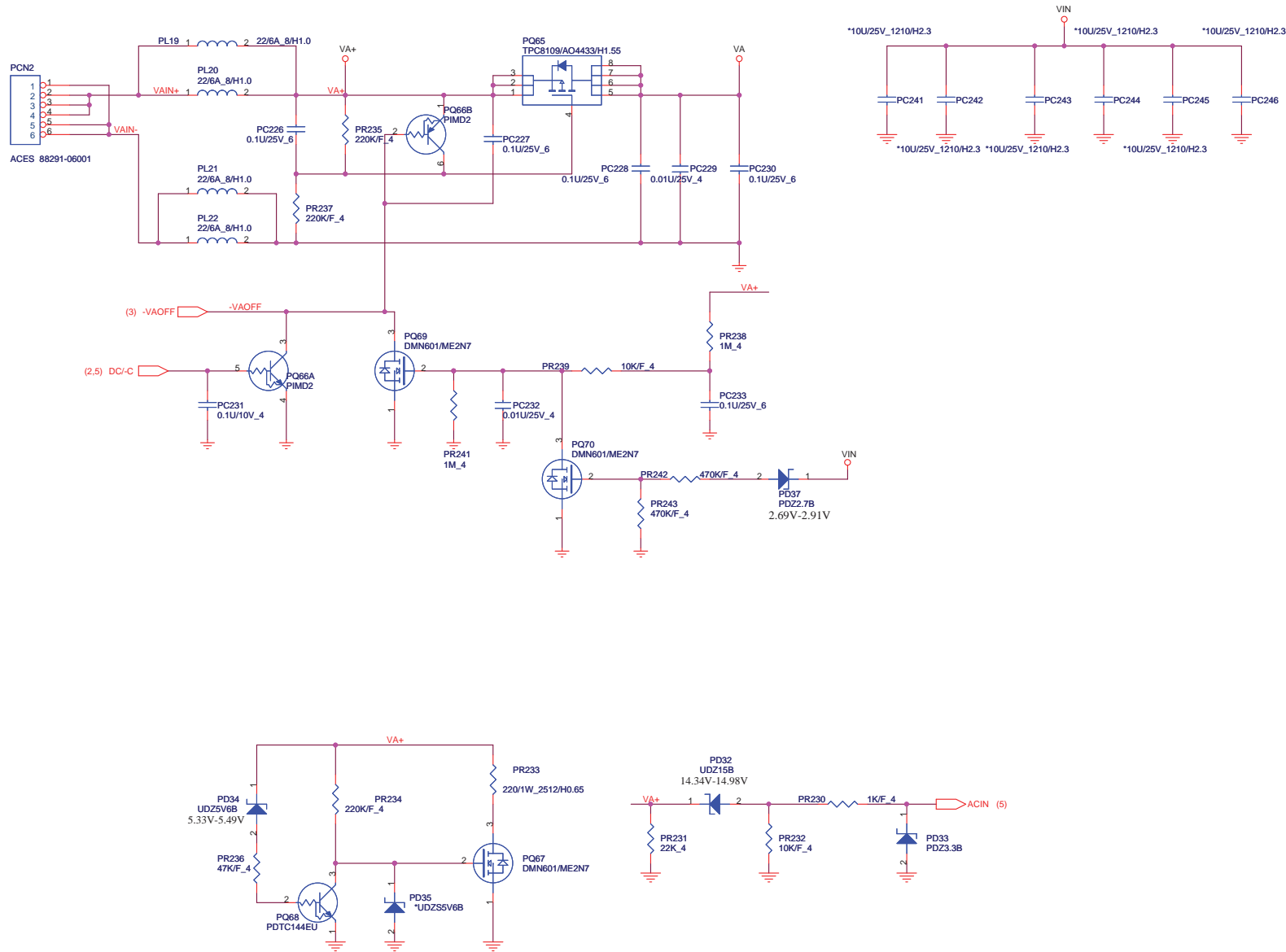

<http://hobi-elektronika.net>
 1.Level 1 Environment-related Substances and their uses
 2.Purchase ink, paint, wire rods, and Molding resins only from the Business Partners that Sony approves as Green Partners.

Title: Adaptor IN	
Size: Custom	Document Number: GD1 Charger Board
Date: Wednesday, July 11, 2007	Rev: 1A
Sheet 4 of 4	

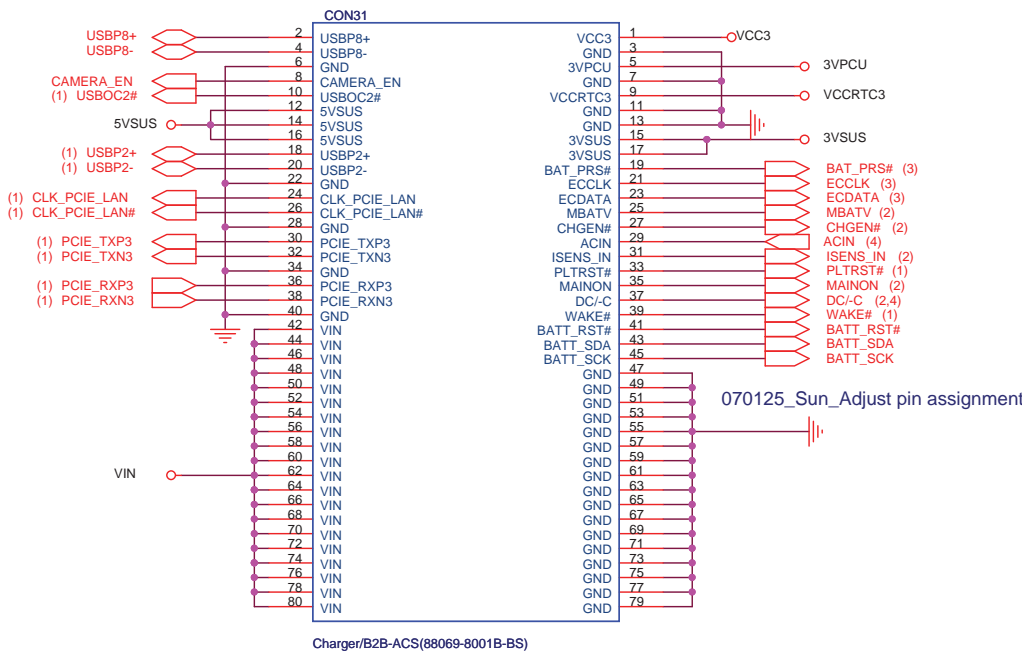

Charger/B2B-ACS(88069-8001B-BS)

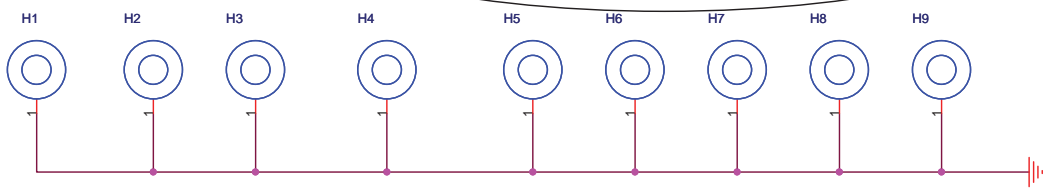
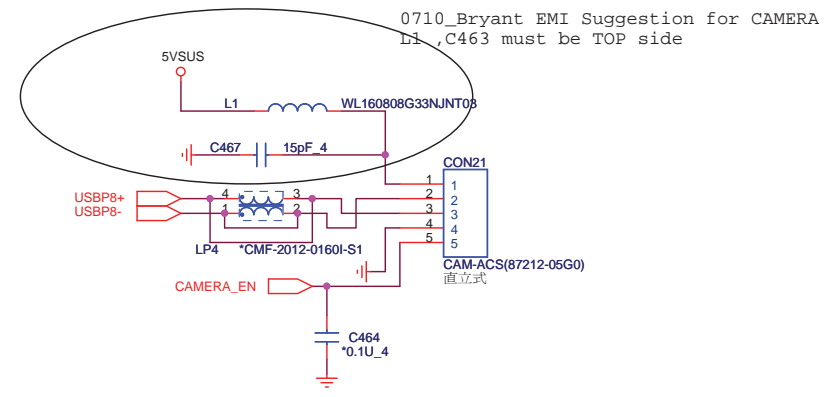
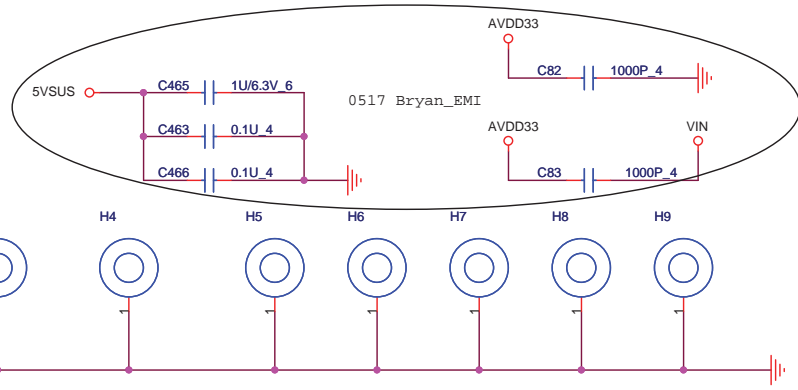
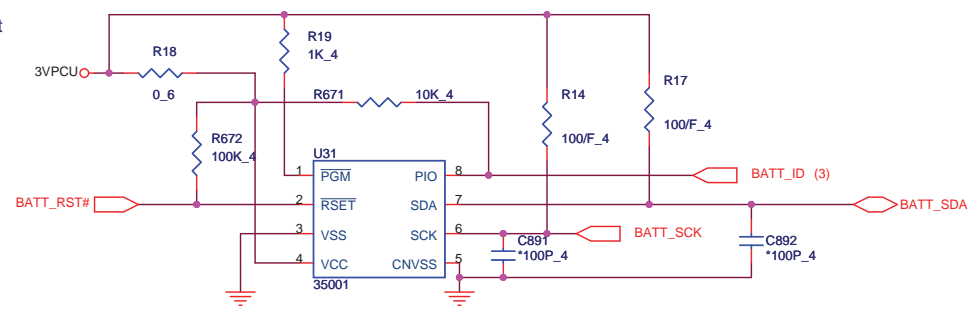

QUANTA COMPUTER

Title: **1.8VSUS & VTT_MEM & Adaptor IN**

Size B Document Number: **GD1 Charger Board** Rev 1A

Date: Wednesday, July 11, 2007 Sheet 5 of 4

1.Level 1 Environment-related Substances Should NEVER be Used.
 2.Purchase ink, paint, wire rods and molding resins only from the business partners that Sony approves as Green Partners.