

Page	Title of schematic page	Rev.	Date
01	Page List	1A	
02	Block Diagram	1A	
03	Change List	1A	
04	HSW MCP(DISPLAY/Sideband)	1A	
05	HSW MCP(MEMORY/GND)	1A	
06	HSW MCP(CFG/PwrMGT)	1A	
07	HSW MCP(POWER)	1A	
08	HSW PCH(RTC/HDA/SATA)	1A	
09	HSW PCH(PCIE/USB)	1A	
10	HSW PCH(CLK/LPC/SPI/SMB)	1A	
11	HSW PCH(GPIO/LPIO/MISC)	1A	
12	HSW PCH(POWER)	1A	
13	DDR3 DIMM0-STD (5.2H)	1A	
14	DDR3 DIMM1-RSV (5.2H)	1A	
15	HOLE/EMI/KB	1A	
16	WPCE985L & FLASH	1A	
17	LVDS/CAMERA	1A	
18	CARD READER(RTS5227E)	1A	
19	HDMI/THERMAL	1A	
20	USB	1A	
21	LAN (RTL8111GS)	1A	
22	WLAN/KB-BL	1A	
23	HDD/ODD/G-SENSOR/TP/FAN	1A	
24	Audio ALC233-CG	1A	
25	LED/PS/DMIC	1A	
26	POWER +VCC_CORE (NCP81101)	1A	
27	POWER 3VPCU&RVCC5(TPS51427)	1A	
28	POWER 1.35VSUS/VTT_MEM	1A	
29	POWER +1.05V(G5602R41U)	1A	
30	POWER VCC1.5/Thermal	1A	
31	POWER(BAT IN / ADA IN/ UL)	1A	
32	POWER CHARGER (ISL88731C)	1A	
33	POWER VGA_CORE/1.0(RT8812A)	1A	
34	<del>POWER VGA_CORE/RANT8812A</del>	1A	
35	NVIDIA N14 GB2-64 PCIE 1/4	1A	
36	NVIDIA N14 GB2-64 TMDS 2/4	1A	
37	NVIDIA N14 GB2-64 VRAM 3/4	1A	
38	NVIDIA N14 GB2-64 VRAM 4/4	1A	
39	AUDIO Woofers	1A	

Page	Title of schematic page	Rev.	Date
40	IO PORT LIST	1A	
		1A	
		1A	
		1A	

\* : No mount  
L@ : For LVDS output  
D@ : For eDP output  
E@ : For DIS GFX  
I@ : For UMA

# HKC Haswell ULT BLOCK DIAGRAM

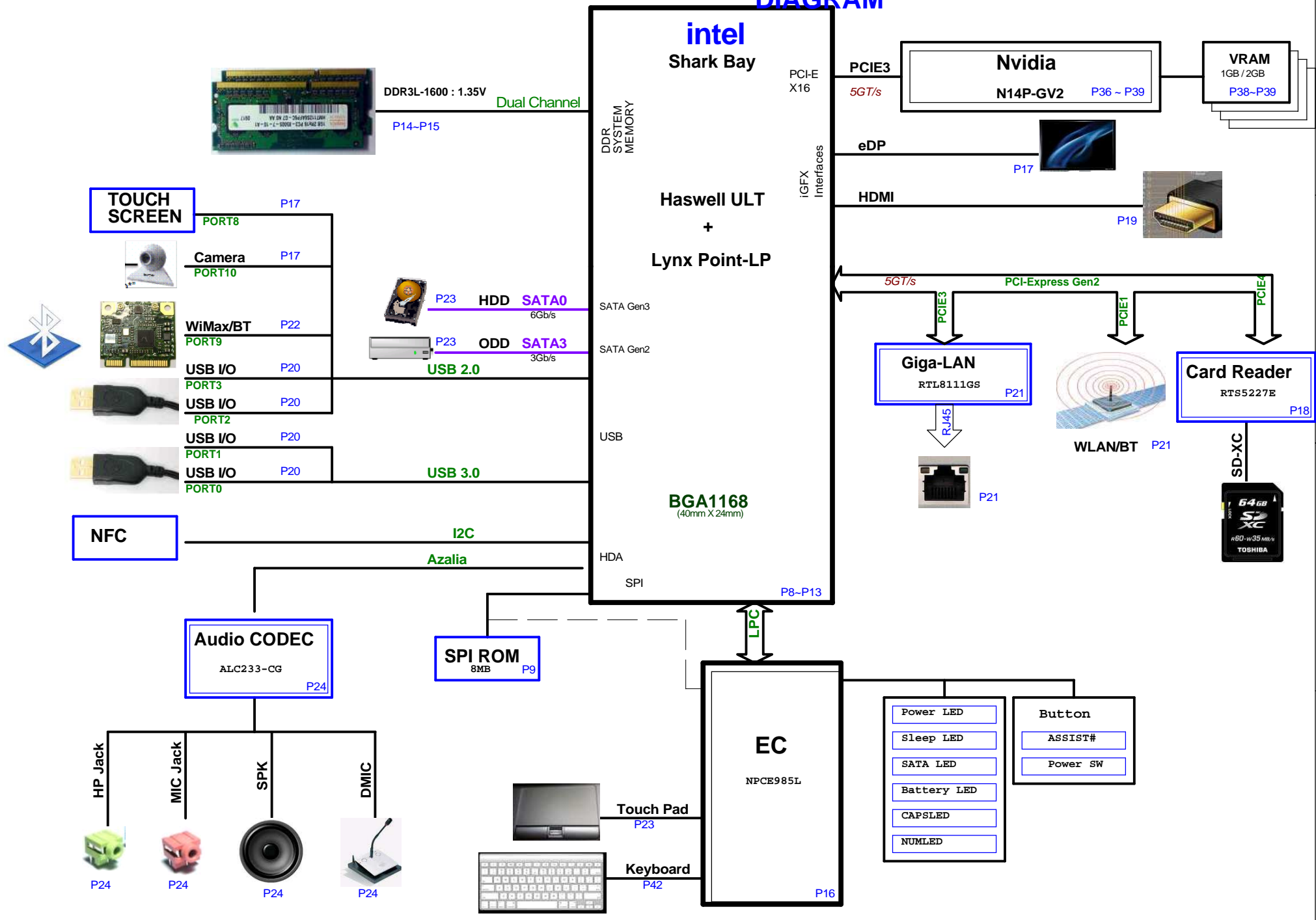

DDR3L-1600 : 1.35V  
Dual Channel  
P14-P15

**TOUCH SCREEN**

P17  
PORT8



Camera P17  
PORT10



WiMax/BT P22  
PORT9



USB I/O P20  
PORT3



USB I/O P20  
PORT2



USB I/O P20  
PORT1



USB I/O P20  
PORT0

**NFC**

**Audio CODEC**  
ALC233-CG  
P24



P24

P24

P24

P24



P23 HDD SATA0  
6Gb/s



P23 ODD SATA3  
3Gb/s

**SPI ROM**  
8MB  
P9



Touch Pad  
P23



Keyboard  
P42

**EC**  
NPCE985L  
P16

- Power LED
- Sleep LED
- SATA LED
- Battery LED
- CAPSLED
- NUMLED

- Button**
- ASSIST#
  - Power SW

**Giga-LAN**  
RTL8111GS  
P21



P21



WLAN/BT P21

**Card Reader**  
RTS5227E  
P18



SD-XC

**Nvidia**  
N14P-GV2 P36 ~ P39

**VRAM**  
1GB / 2GB  
P38-P39



P17



P19

**intel Shark Bay**

DDR SYSTEM MEMORY

**Haswell ULT + Lynx Point-LP**

SATA Gen3

SATA Gen2

USB

HDA

SPI

**BGA1168**  
(40mm X 24mm)

P8-P13

PCI-E X16

PCI-E3 5GT/s

eDP

HDMI

5GT/s

PCI-Express Gen2

PCI-E3

PCI-E1

PCI-E3

RJ45

SD-XC

D

D

C

C

B

B

A

A

		<b>Quanta Computer Inc.</b>
		PROJECT :HKC
Size	Document Number	Rev
	<b>Change List</b>	1A
Date:	Thursday, January 24, 2013	Sheet 3 of 40

# Haswell ULT (DISPLAY)

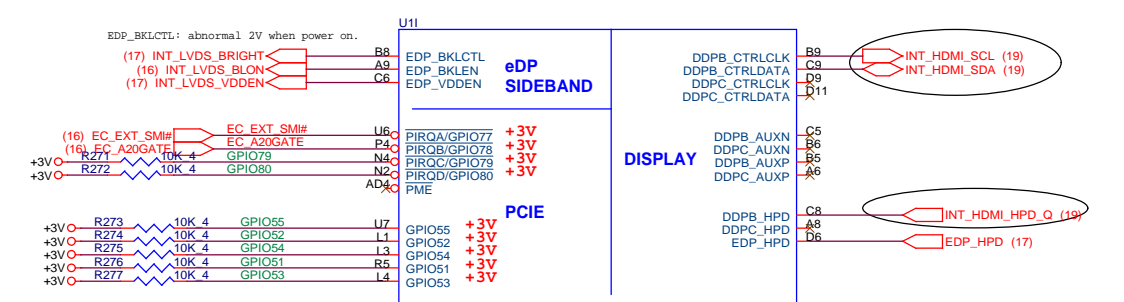
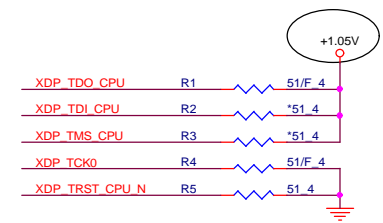
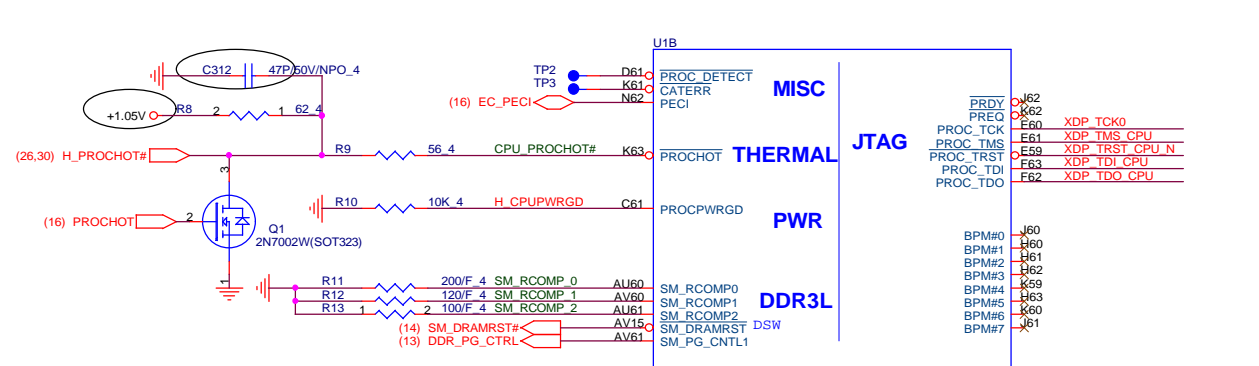
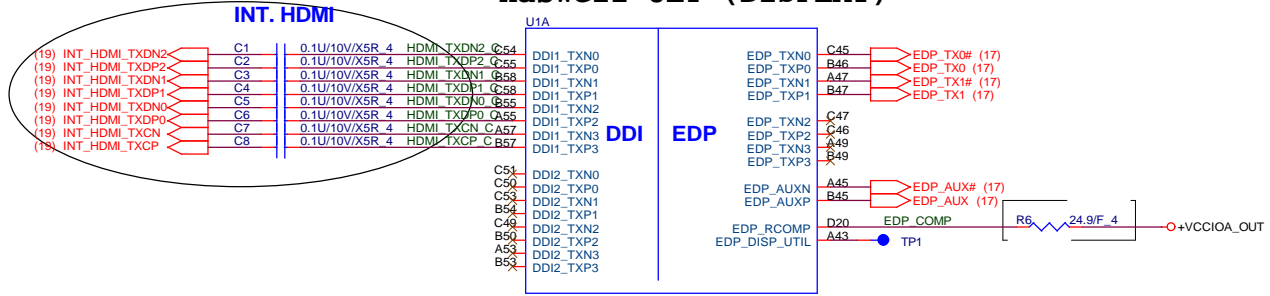

**Quanta Computer Inc.**  
 PROJECT : HKC

Size Document Number  
 HSW MCP(Display/eDP) Rev 1A

Date: Thursday, January 31, 2013 Sheet 4 of 40

1. Level 1 Environment-related Substances Should Never be Used.  
 2. Recycled Resin and Coated Wire should be procured from Green Partners.

# Haswell ULT (DDR3L)

M\_A\_DQ[63:0] (13)

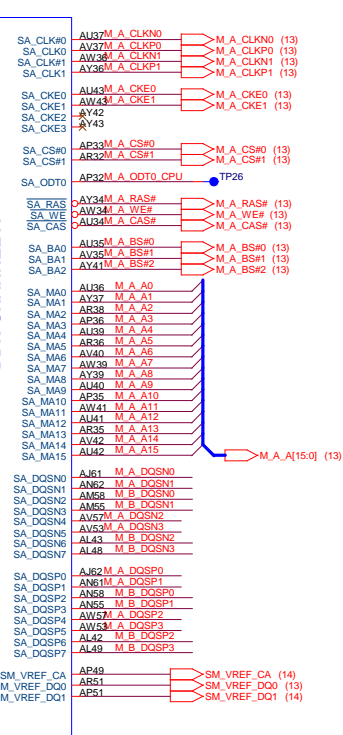
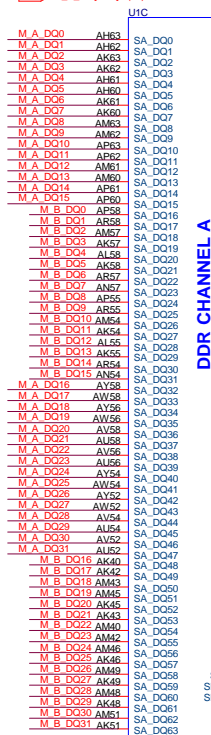

M\_B\_DQ[63:0] (14)

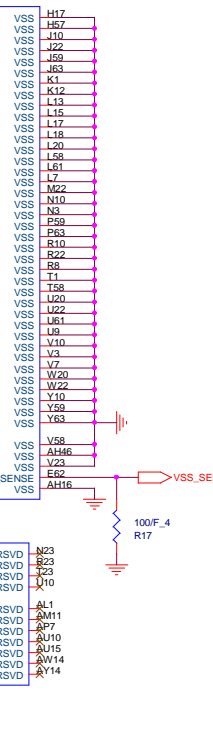
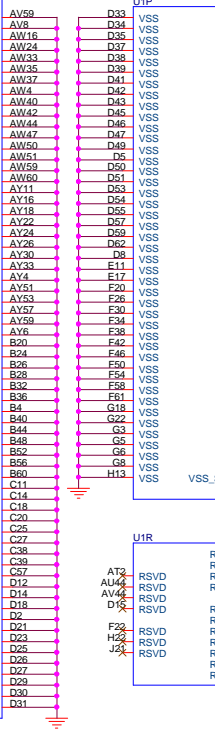
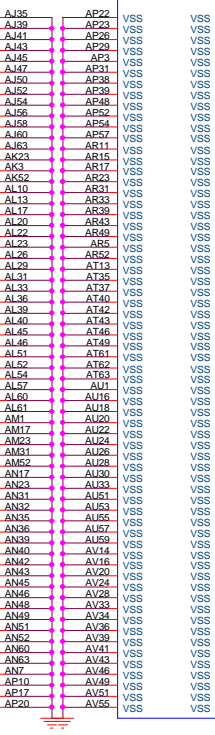
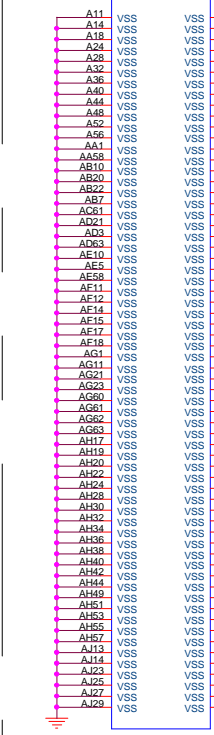
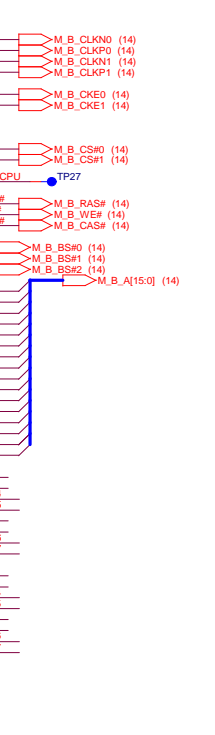
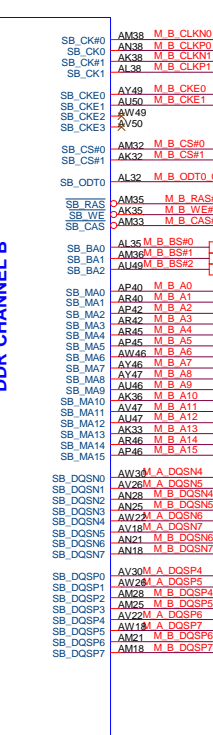
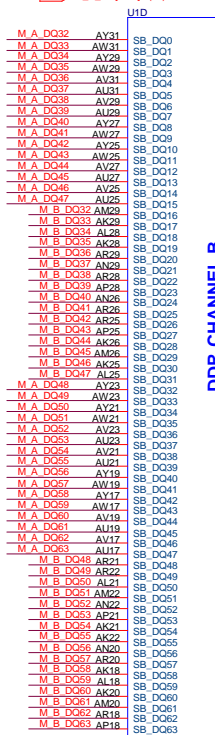

M\_A\_DQS[7:0] (13)

M\_A\_DQSP[7:0] (13)

M\_B\_DQS[7:0] (14)

M\_B\_DQSP[7:0] (14)

M\_B\_DQS[7:0] (14)

M\_B\_DQSP[7:0] (14)

# HSW ULT (GND)

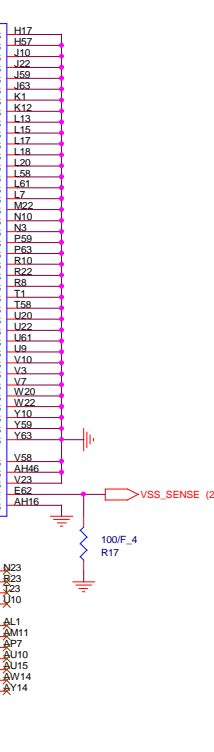
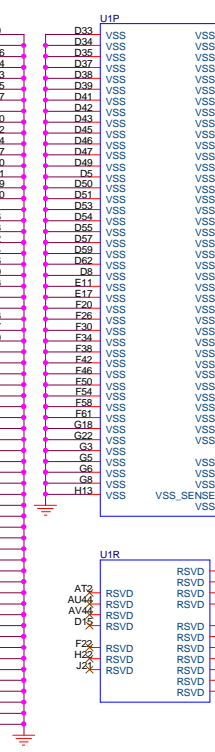
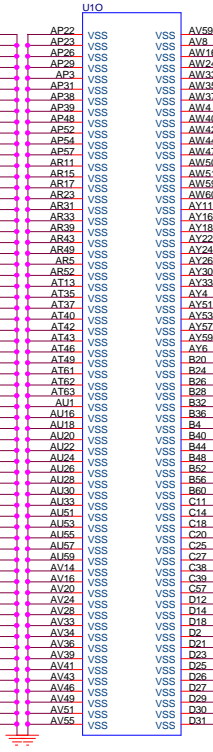
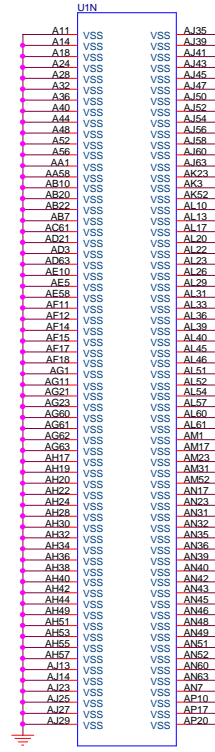

TP29

TP31

DC TEST AY2 AW2 AY2

TP DC TEST AY3 AW3 AY3

DC TEST AY6 AW6 AY6

TP DC TEST E2 B2

DC TEST A3 B3 B3

DC TEST B62 B63 B63

DC TEST C1 C2 C2

DAISY\_CHAIN\_NCTF\_AY2

DAISY\_CHAIN\_NCTF\_AY3

DAISY\_CHAIN\_NCTF\_AY6

DAISY\_CHAIN\_NCTF\_B2

DAISY\_CHAIN\_NCTF\_B3

DAISY\_CHAIN\_NCTF\_B62

DAISY\_CHAIN\_NCTF\_C1

DAISY\_CHAIN\_NCTF\_A3

DAISY\_CHAIN\_NCTF\_A4

DAISY\_CHAIN\_NCTF\_A60

DAISY\_CHAIN\_NCTF\_A61

DAISY\_CHAIN\_NCTF\_A62

DAISY\_CHAIN\_NCTF\_A63

DAISY\_CHAIN\_NCTF\_A66

A3 DC TEST A3 B3

TP DC TEST A4

TP DC TEST A60

TP DC TEST A61 B61

TP DC TEST A62

TP DC TEST A63

TP DC TEST A66

A4

A60

A61

A62

A63

A66

B61

B62

B63

C1

C2

DAISY\_CHAIN\_NCTF\_A60

DAISY\_CHAIN\_NCTF\_A61

DAISY\_CHAIN\_NCTF\_A62

DAISY\_CHAIN\_NCTF\_A63

DAISY\_CHAIN\_NCTF\_A66

DAISY\_CHAIN\_NCTF\_A66

DAISY\_CHAIN\_NCTF\_A66

A3

A4

A60

A61

A62

A63

A66

TP28

TP30

TP32

TP33

TP34

TP35

1. Level 1 Environment-related Substances Should Never be Used.  
 2. Recycled Resin and Coated Wire should be procured from Green Partners.

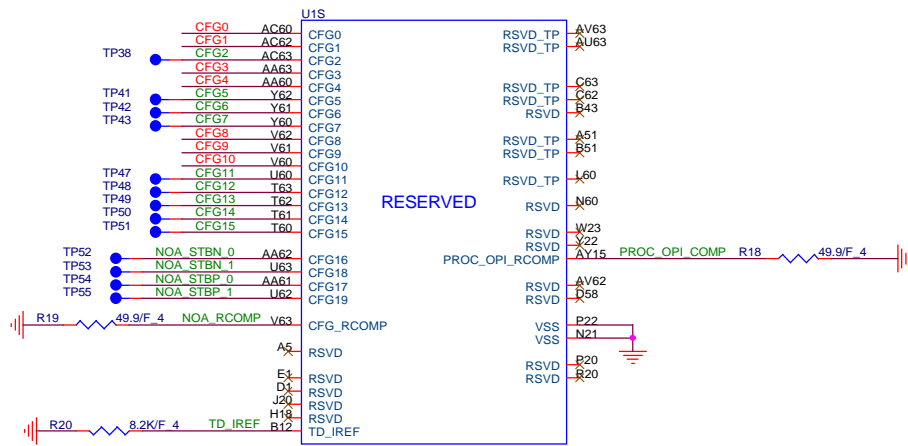

**Processor Strapping**

	1	0	
CFG0 EAR-STALL/NOT STALL RESET SEQUENCE AFTER PCU PLL IS LOCKED	(DEFAULT) NORMAL OPERATION; NO STALL	STALL	
CFG1 PCH/ PCH LESS MODE SELECTION	(DEFAULT) NORMAL OPERATION	PCH-LESS MODE	
CFG3 PHYSICAL_DEBUG_ENABLED (DFX PRIVACY)	DISABLED	ENABLED SET DFX ENABLED BIT IN DEBUG INTERFACE MSR	
CFG4 DISPLAY PORT PRESENCE STRAP	DISABLED NO PHYSICAL DISPLAY PORT ATTACHED TO EMBEDDED DISPLAY PORT	ENABLED; NOA WILL BE AVAILABLE REGARDLESS OF THE LOCKING OF THE UNIT	
CFG 8 ALLOW THE USE OF NOA ON LOCKED UNITS	DISABLED(DEFAULT); IN THIS CASE, NOA WILL BE DISABLED IN LOCKED UNITS AND ENABLED IN UN-LOCKED UNITS	ENABLED AN EXTERNAL DISPLAY PORT DEVICE IS CONNECTED TO THE EMBEDDED DISPLAY PORT	
CFG9 NO SVID PROTOCOL CAPABLE VR CONNECTED	VRS SUPPORTING SVID PROTOCOL ARE PRESENT	NO VR SUPPORTING SVID IS PRESENT. THE CHIP WILL NOT GENERATE (OR RESPOND TO) SVID ACTIVITY	
CFG10 SAFE MODE BOOT	POWER FEATURES ACTIVATED DURING RESET	POWER FEATURES (ESPECIALLY CLOCK GATINE ARE NOT ACTIVATED	





**Quanta Computer Inc.**

PROJECT : HKC

1. Level 1 Environment-related Substances Should Never be Used.  
 2. Recycled Resin and Coated Wire should be procured from Green Partners.

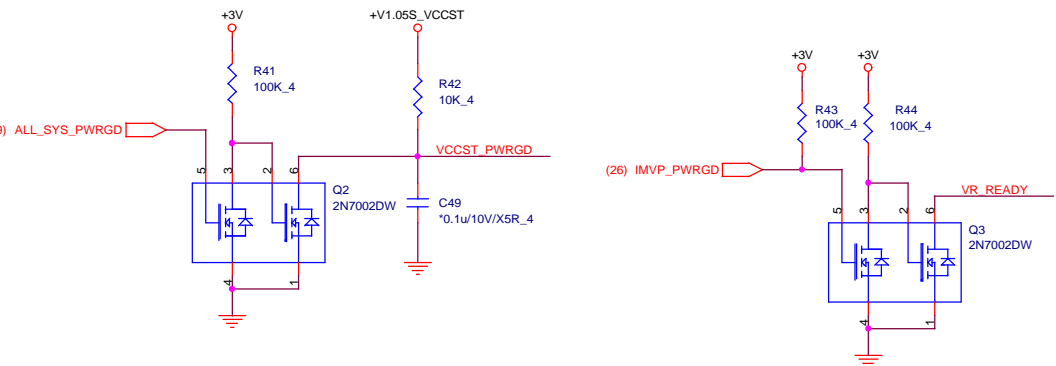
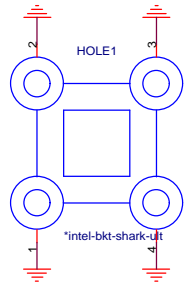
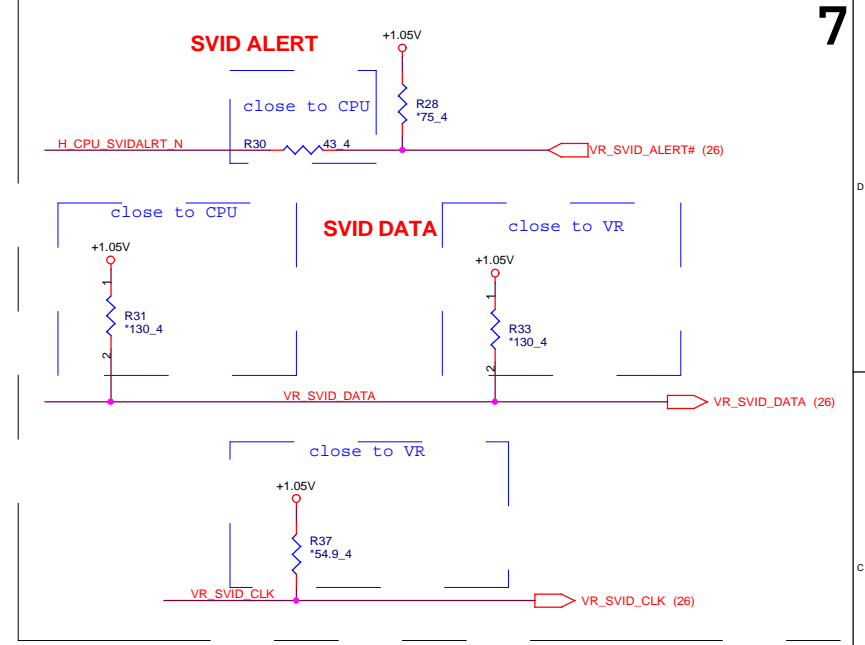
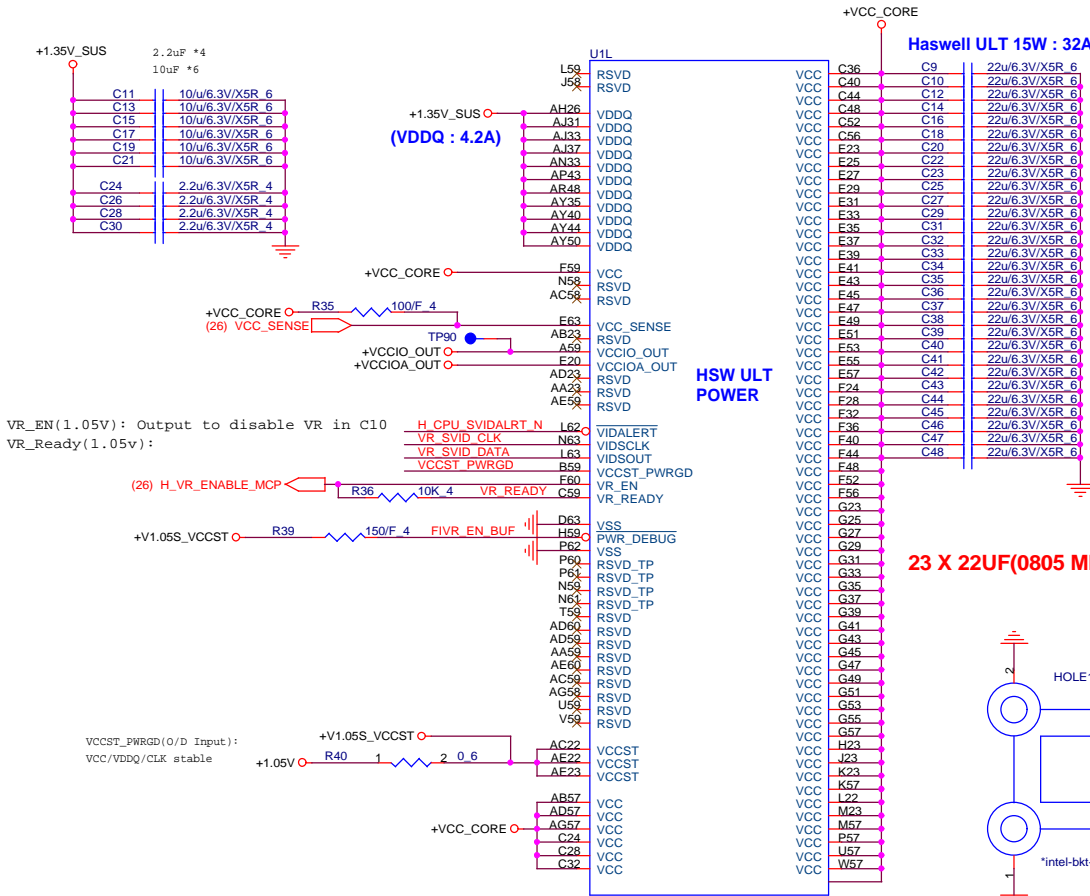
# Haswell ULT MCP(Power)





**Quanta Computer Inc.**  
PROJECT : HKC

Size	Document Number	Date: Thursday, January 31, 2013	Sheet 7 of 40
<b>HSW MCP(Power)</b>			Rev 1A

1. Level 1 Environment-related Substances Should Never be Used.  
2. Recycled Resin and Coated Wire should be procured from Green Partners.

# Haswell ULT (RTC, HDA, JTAG, SATA)

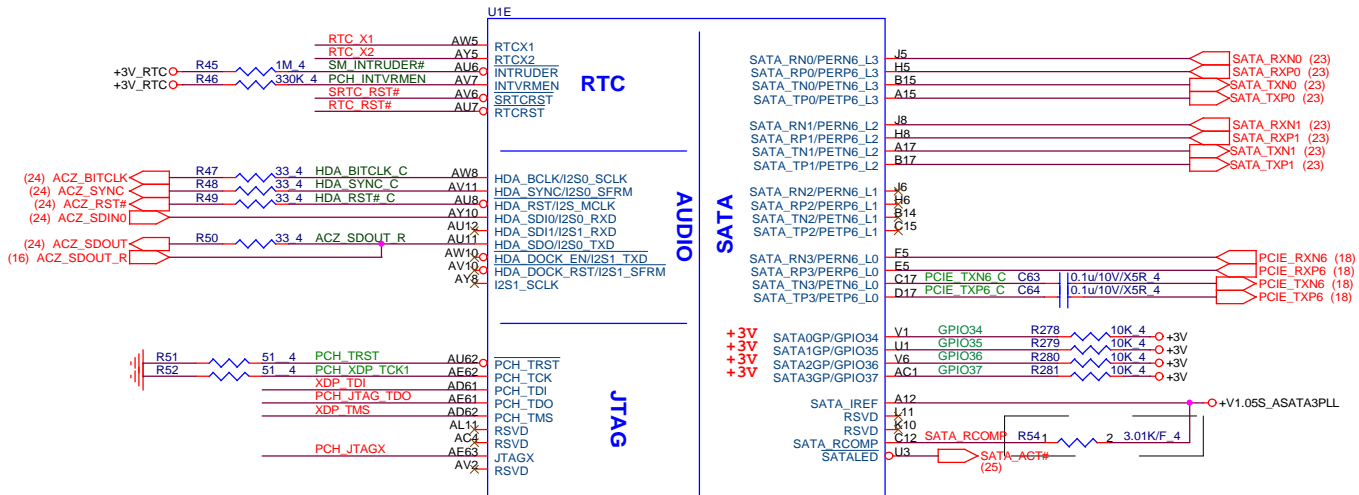

HDD  
 ODD  
 Card Reader

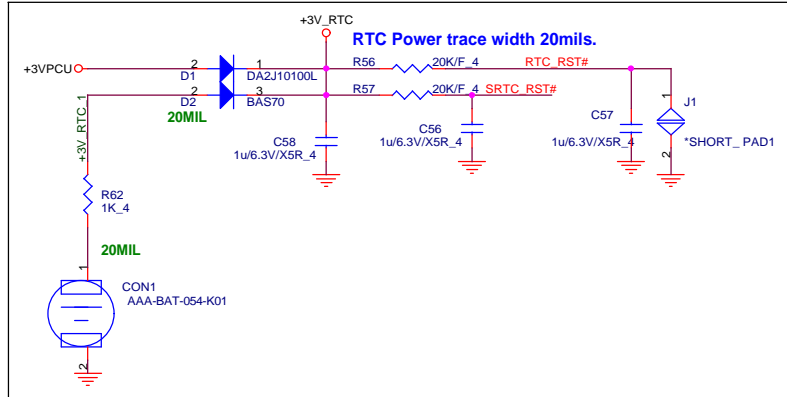
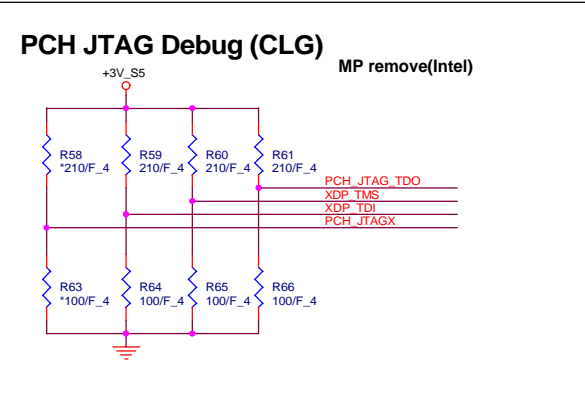
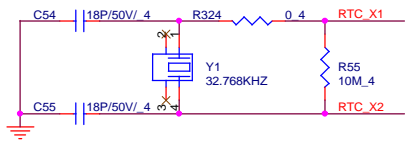

## PCH Strap Table

Pin Name	Strap description	Sampled	Configuration	note
SPKR	No reboot mode setting	PWROK	0 = Default (weak pull-down 20K) 1 = Setting to No-Reboot mode	+3V — R67 — *1K 4 —> SPKR (11,24)
HDA_SDO	Flash Descriptor Security Override / Intel ME Debug	PWROK	0 = Security Effect (Int PD) 1 = Can be Override	
INTVRMEN	Integrated 1.05V VRM enable	ALWAYS	<b>Should be always pull-up</b>	



**Quanta Computer Inc.**  
 PROJECT : HKC

Size	Document Number	Date: Friday, February 01, 2013
<b>HSW PCH(RTC/HDA/SATA)</b>		Rev 1A
Sheet 8 of 40		

1. Level 1 Environment-related Substances Should Never be Used.  
 2. Recycled Resin and Coated Wire should be procured from Green Partners.



### Haswell ULT (PCIE,USB)

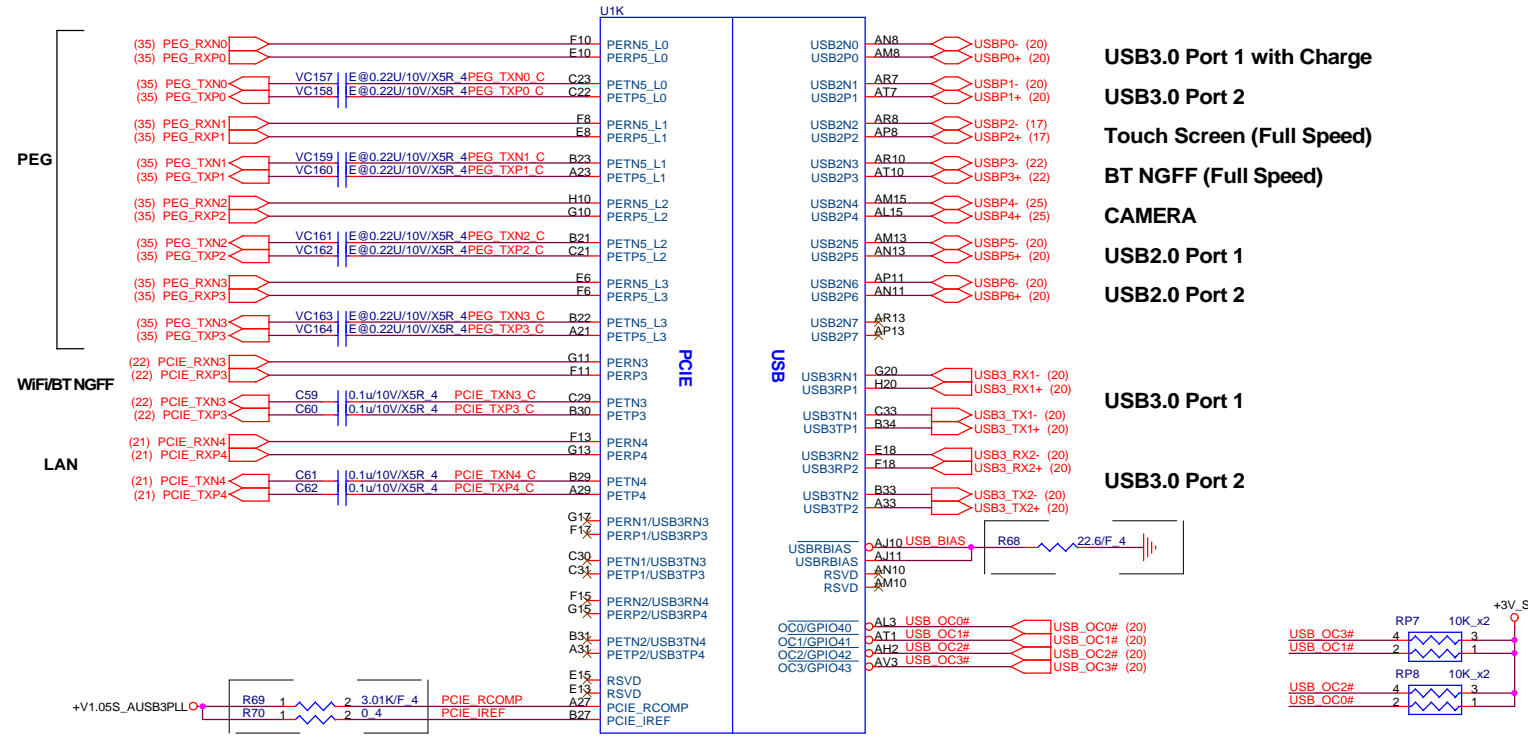

- USB3.0 Port 1 with Charge
- USB3.0 Port 2
- Touch Screen (Full Speed)
- BT NGFF (Full Speed)
- CAMERA
- USB2.0 Port 1
- USB2.0 Port 2
- USB3.0 Port 1
- USB3.0 Port 2

### Haswell ULT (SYSTEM POWER MANAGEMENT)

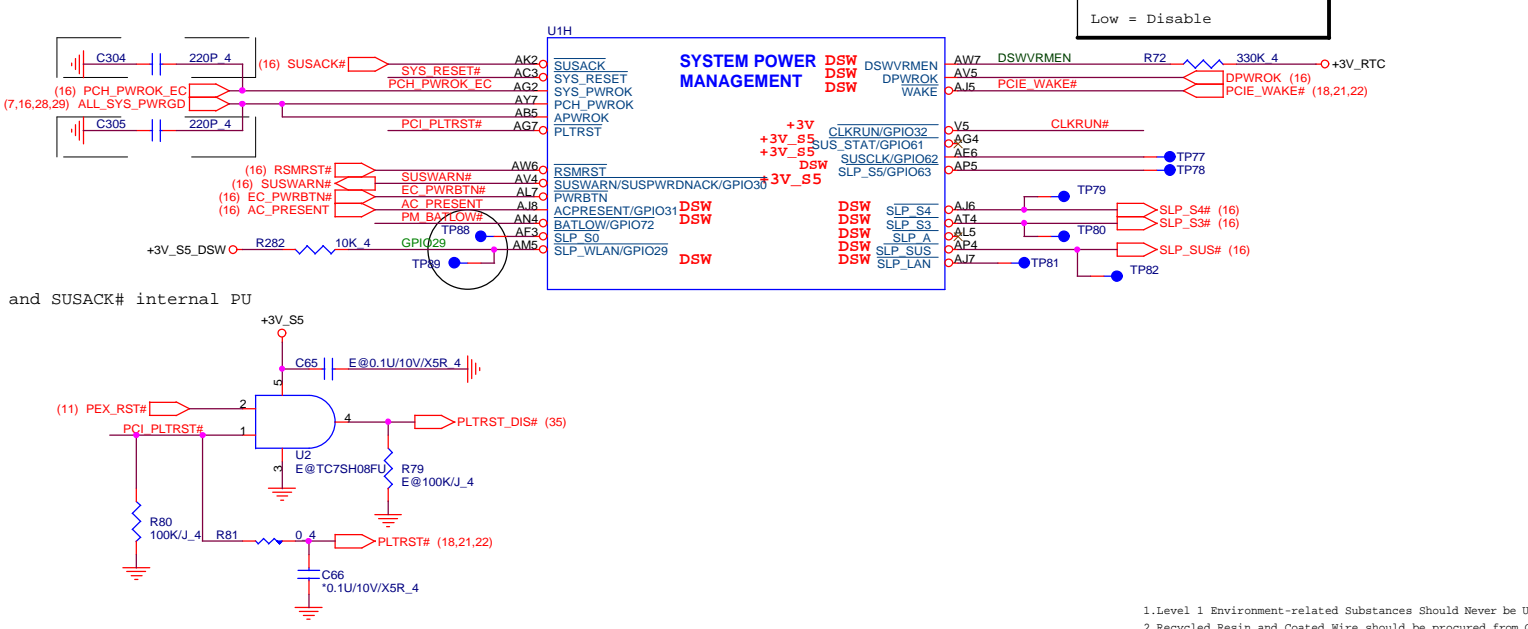

On Die DSW VR Enable  
 High = Enable (Default)  
 Low = Disable

### PCH Pull-high/low(CLG)

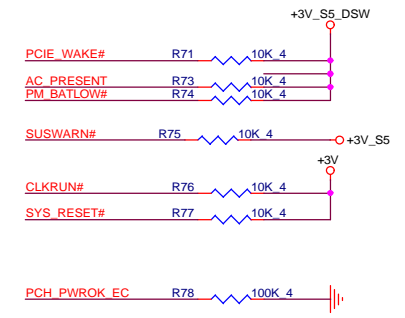

**Quanta Computer Inc.**  
PROJECT : HKC

Size	Document Number	Rev 1A
<b>HSW PCH(PCIE/USB)</b>		

1. Level 1 Environment-related Substances Should Never be Used.  
 2. Recycled Resin and Coated Wire should be procured from Green Partners.

Date: Thursday, January 31, 2013 Sheet 9 of 40

### Haswell ULT (CLK)

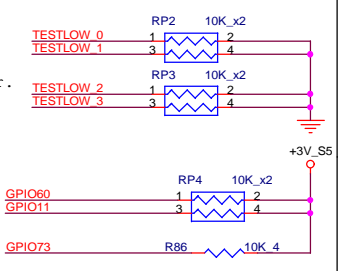
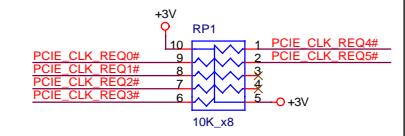
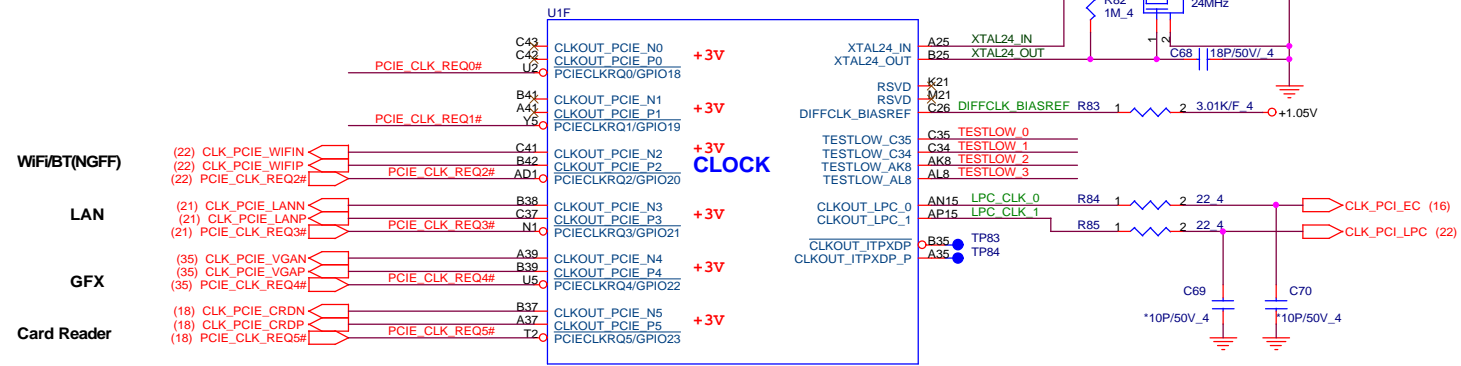

Do not short the testlow pins together.

### Haswell ULT (LPC/SPI/SMB/CLINK)

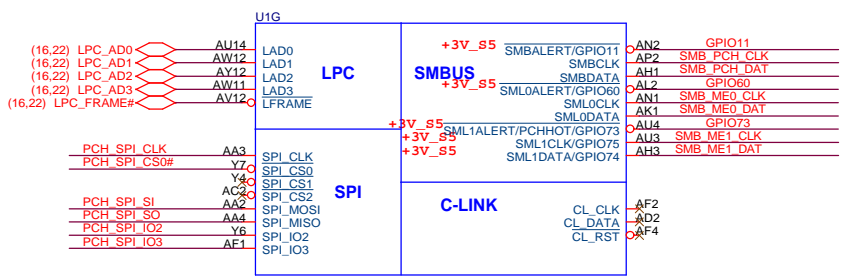

### SMBus/Pull-up(CLG)

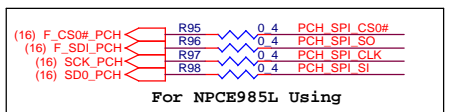
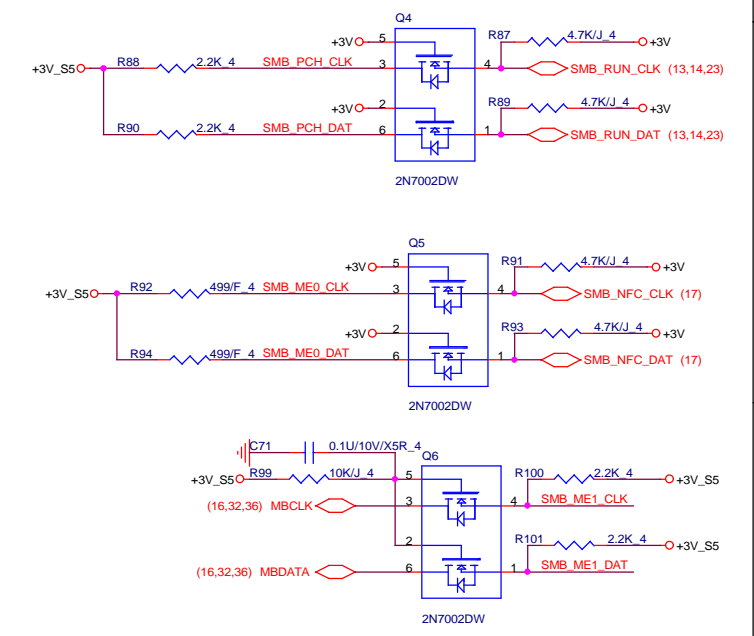

### SPI FLASH

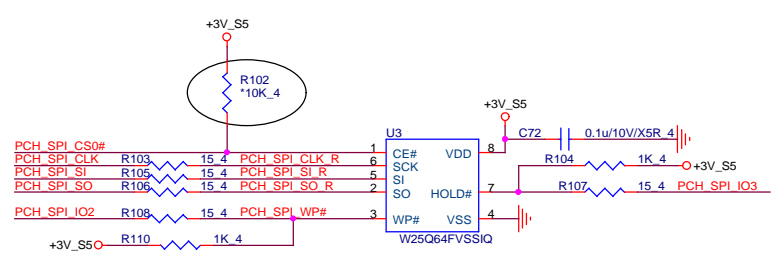

1. Level 1 Environment-related Substances Should Never be Used.  
2. Recycled Resin and Coated Wire should be procured from Green Partners.

**Quanta Computer Inc.**  
PROJECT : HKC

Size	Document Number	Rev
		1A
Date:	Thursday, January 31, 2013	Sheet 10 of 40

**GPIO27**  
 With Intel LAN:  
 Connect to LANWAKE# pin on the LAN  
 Without Intel LAN:  
 Used to wake event from DSx

**Hasswell ULT(GPIO,LPIO,MISC)**

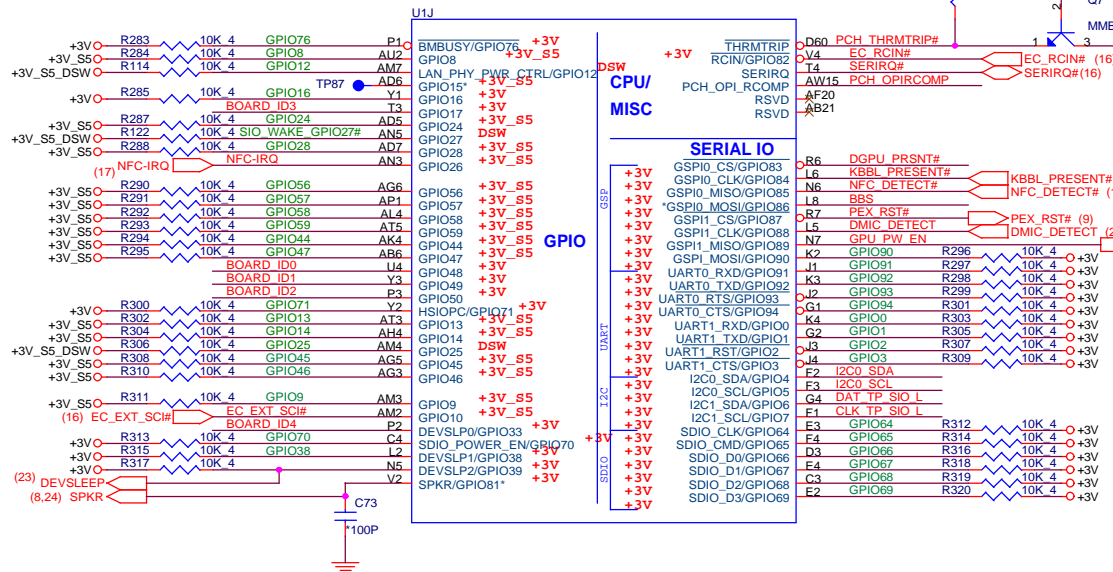

**DMIC\_DETECT:**  
 High : Single DMIC  
 Low : Dual DMIC

**GPIO Pull-up/Pull-down(CLG)**

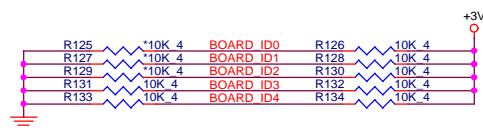
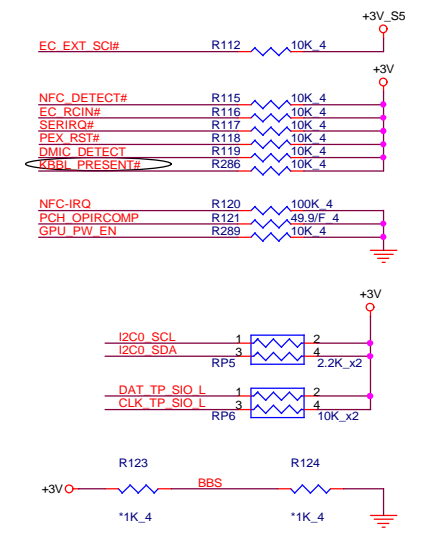

	0	1
Board ID0	CaspISHAL-CaspISHB1 HKC/HKD	SuperiorSHAL-SuperiorSHB1 GD9/GDA
Board ID1	HKC1/GD9 14"	HKD-GDA 15"

PCBA SKU	Discrete	UMA
R277(Pull High)	Stuff	No Stuff
R275(Pull Low)	No Stuff	Stuff

GPIO86	
PU	LPC
PD	SPI (Default IPD)

No Reboot Strap(GPIO81)	
NC	Default
PU	EN

TLS CONFIDENTIALITY STRAP(GPIO15)	
NC	Default
PU	EN

**Quanta Computer Inc.**  
 PROJECT : HKC

Size	Document Number	Rev
	HSW PCH(GPIO/MISC)	1A

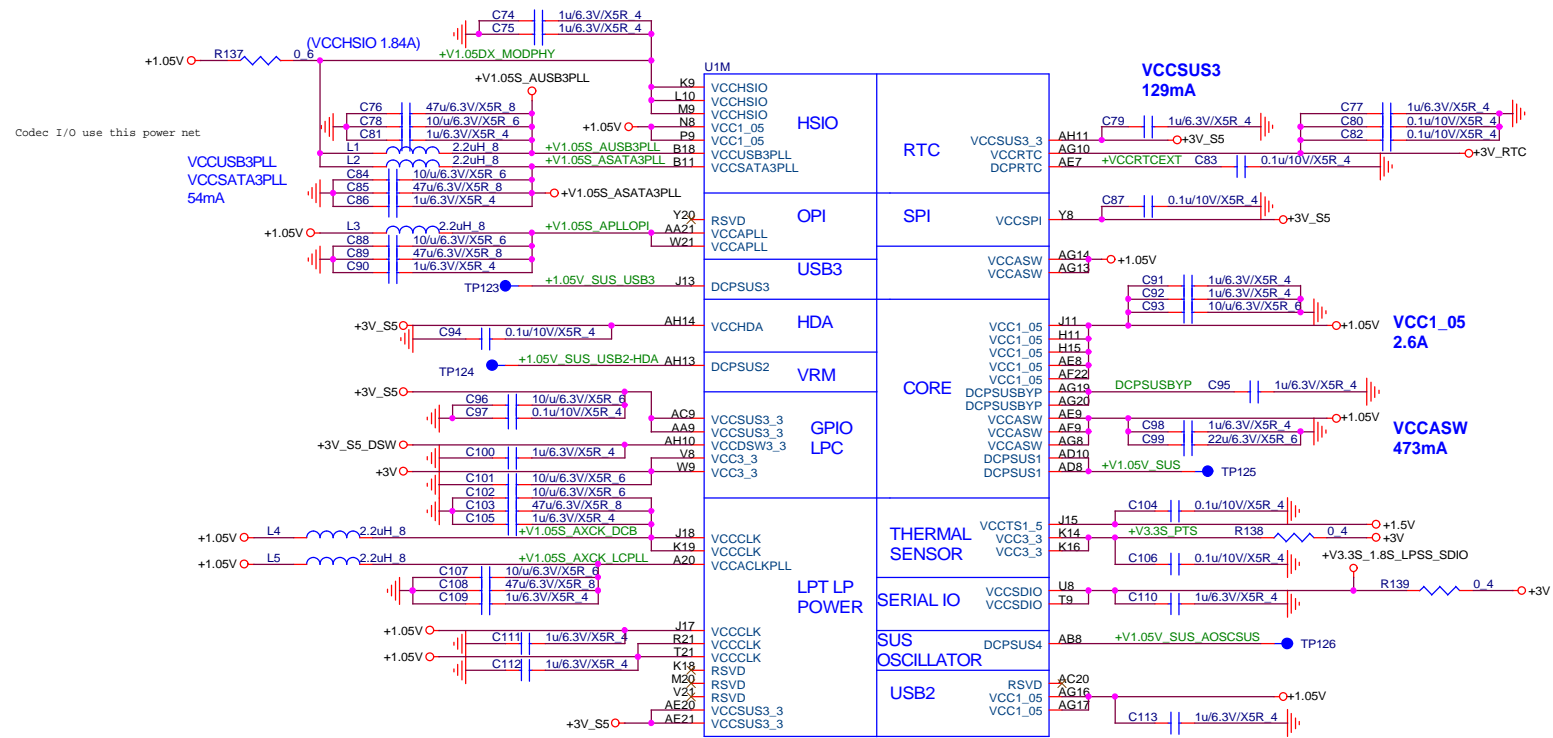

**DEEP STANDBY**

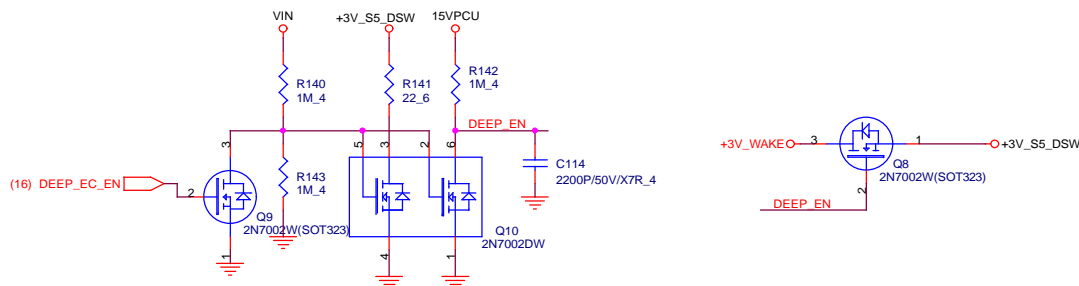

		<b>Quanta Computer Inc.</b> PROJECT : HKC	
		Size Document Number <b>HSW PCH(Power)</b>	Rev 1A
1.Level 1 Environment-related Substances Should Never be Used. 2.Recycled Resin and Coated Wire should be procured from Green Partners.		Date: Thursday, January 31, 2013	Sheet 12 of 40

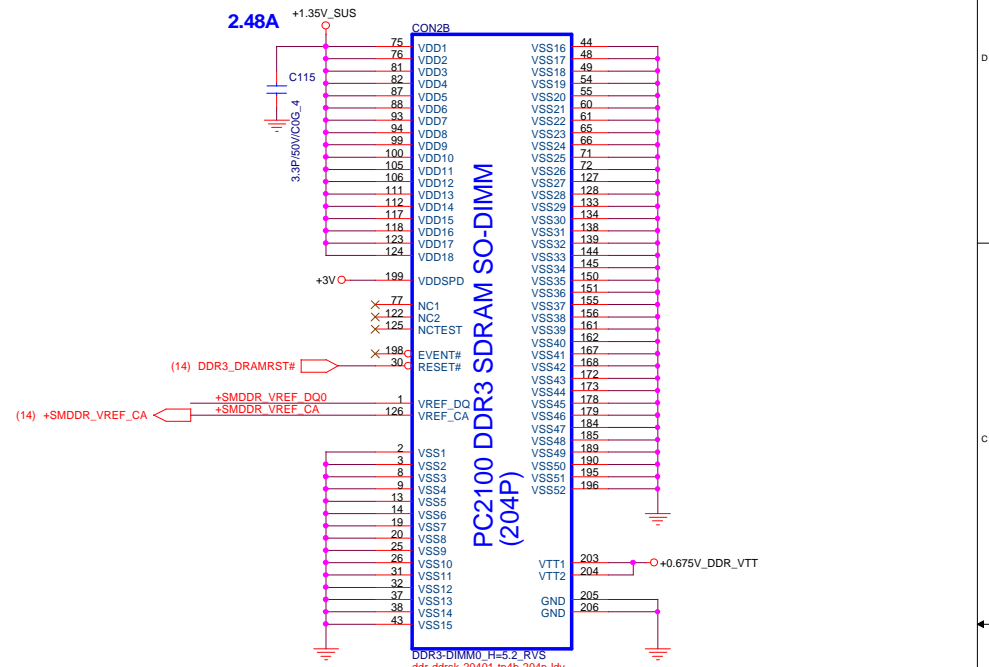
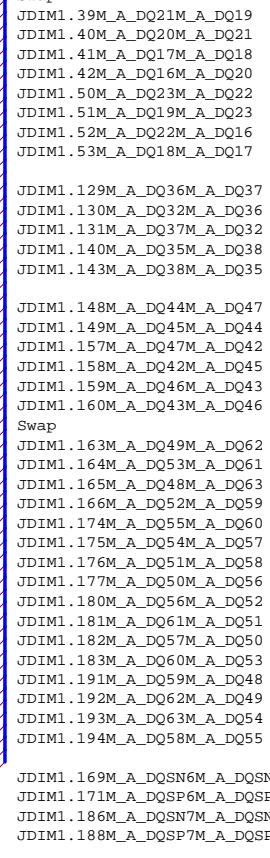
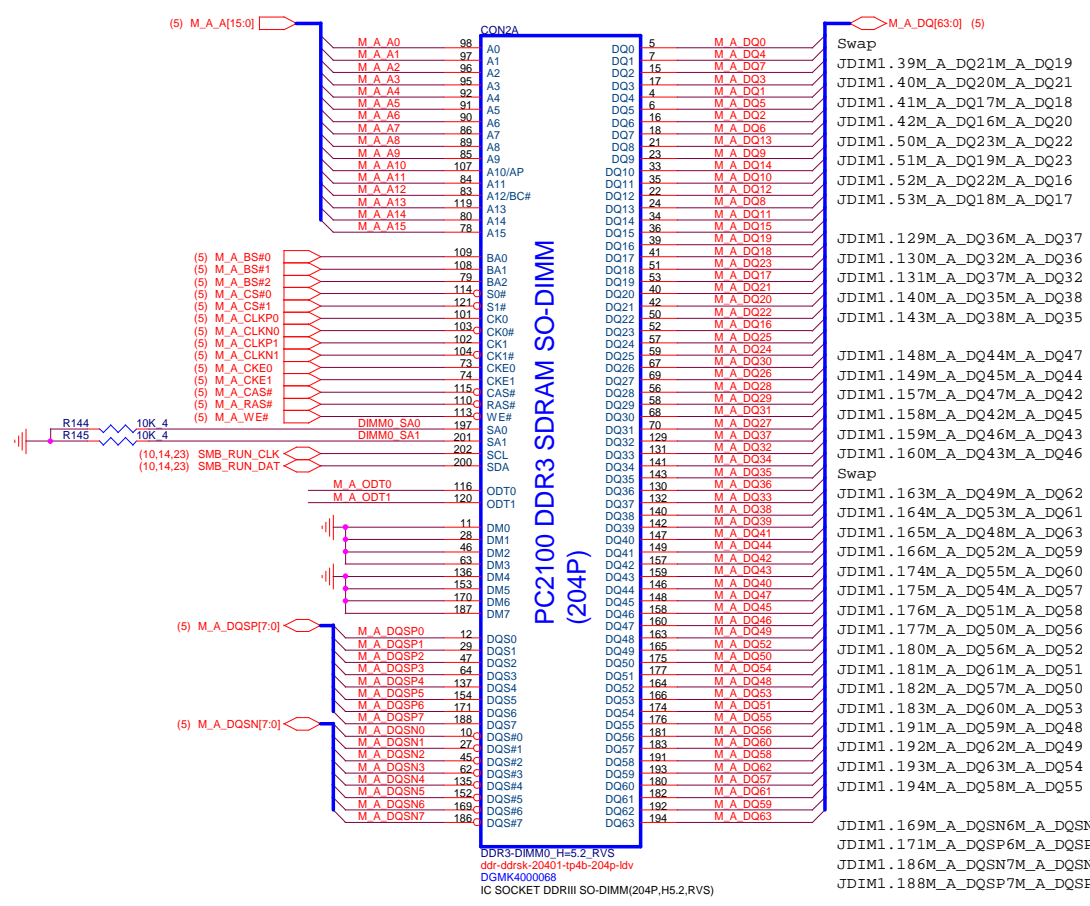

DDR3L SODIMM ODT GENERATION

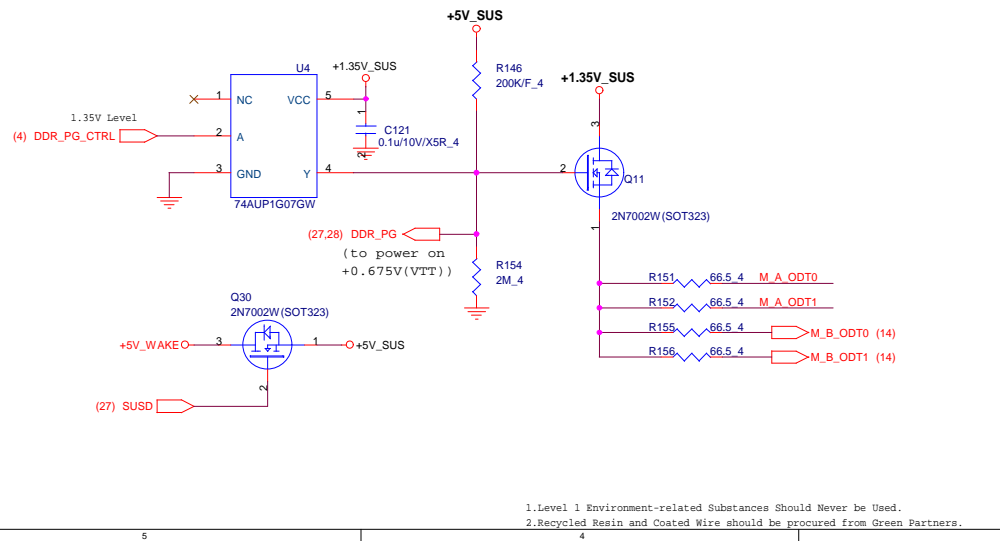

Place these Caps near So-Dimm0.

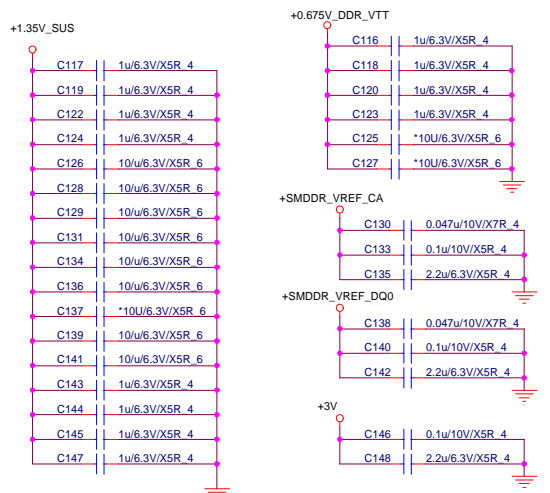

VREF DQ0 M1/M3 Solution

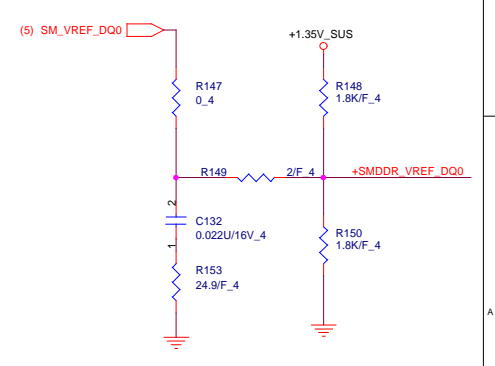

**Quanta Computer Inc.**

PROJECT : HKC

Rev 1A

Size Document Number

DDR3 DIMM0

Date: Thursday, January 24, 2013 Sheet 13 of 40

1.Environment-related Substances Should Never be Used.  
2.Recycled Resin and Coated Wire should be procured from Green Partners.

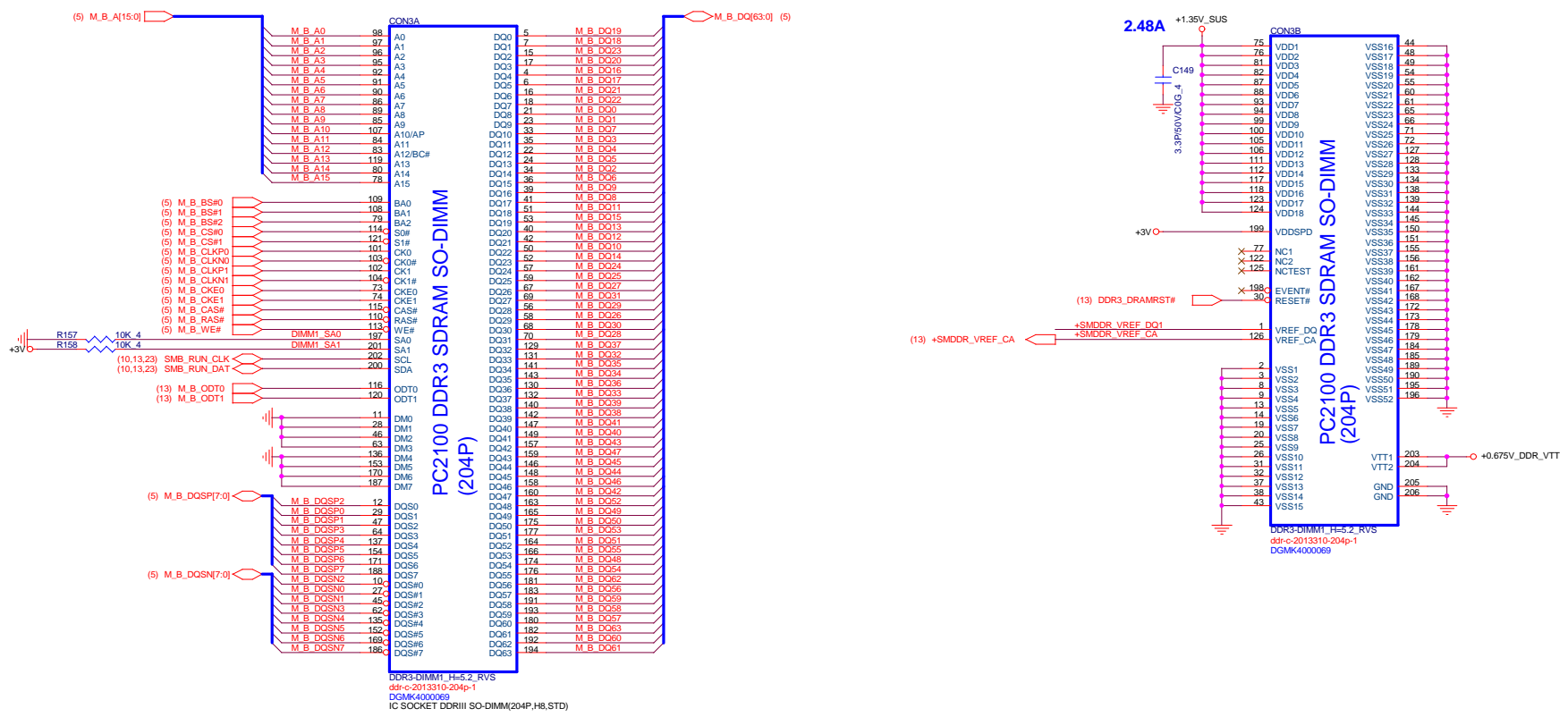

### Haswell ULT DRAMRST#

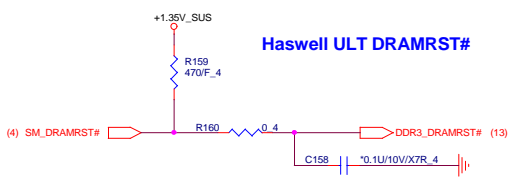

### Place these Caps near So-Dimm1

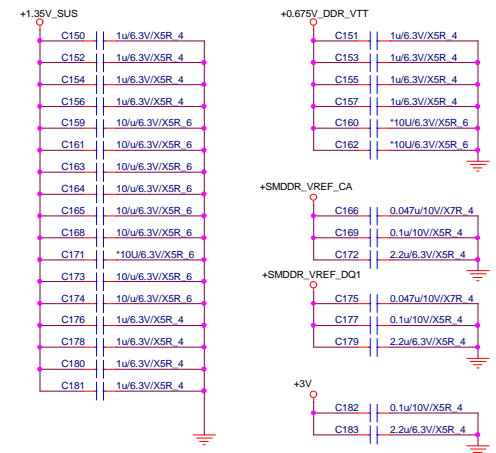

### VREF DQ1 Solution

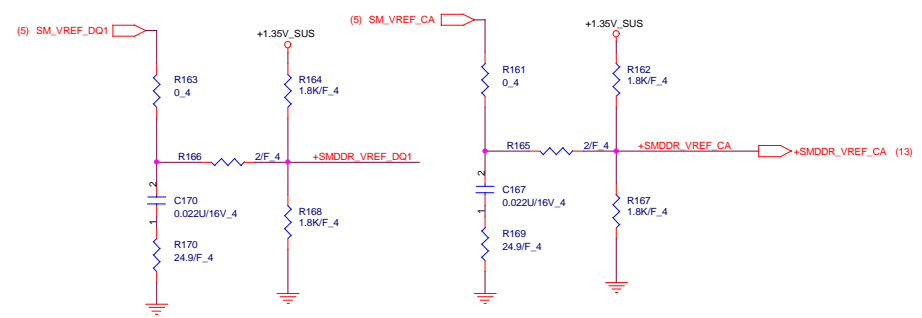

**Quanta Computer Inc.**

PROJECT : HKC

DDR3 DIMM1

Size Document Number Rev 1A

1.Level 1 Environment-related Substances Should Never be Used.  
2.Recycled Resin and Coated Wire should be procured from Green Partners.

Date: Thursday, January 24, 2013 Sheet 14 of 40

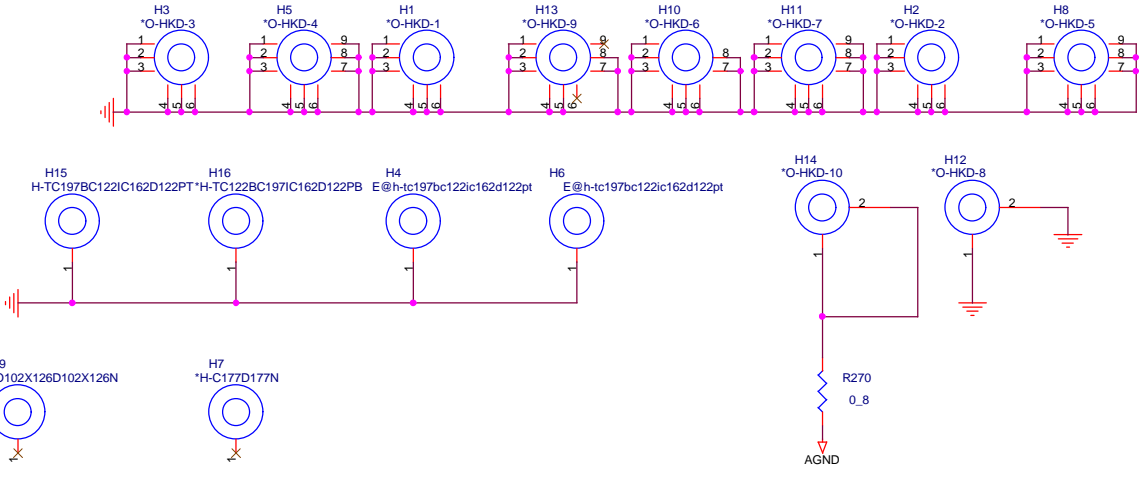

**KEY BOARD Connector**

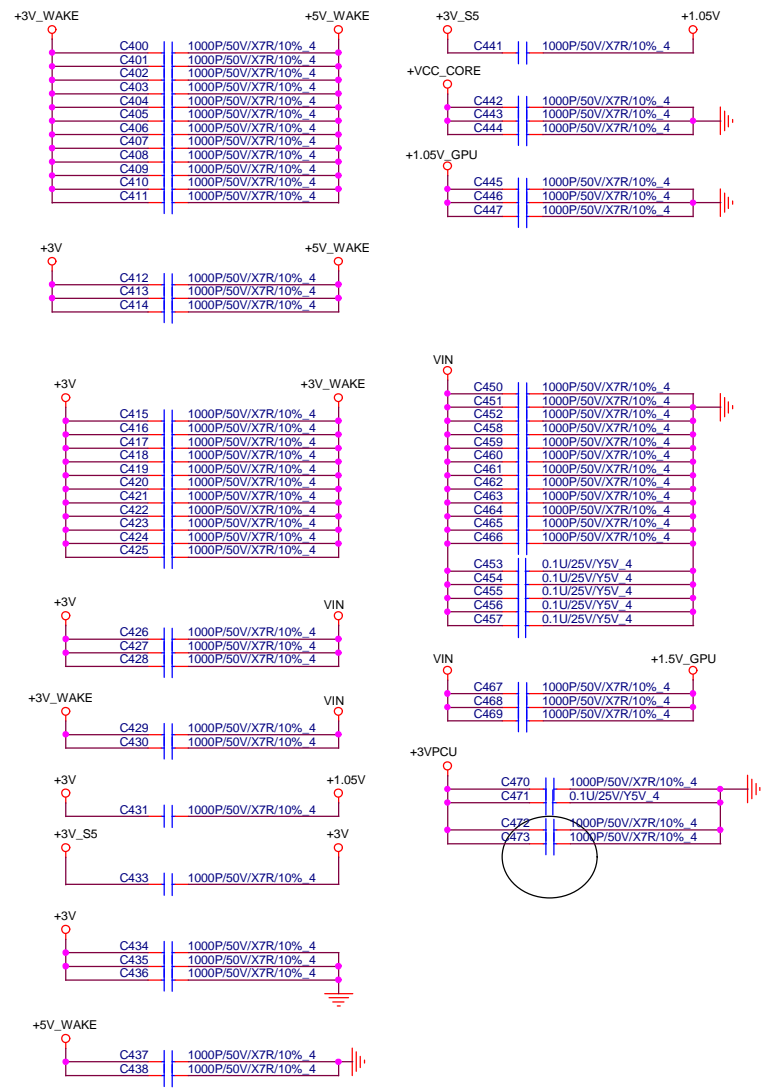
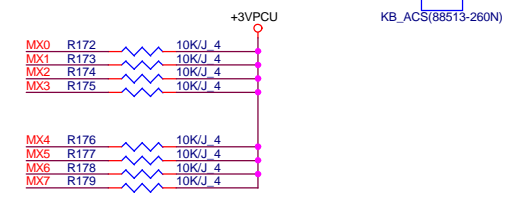
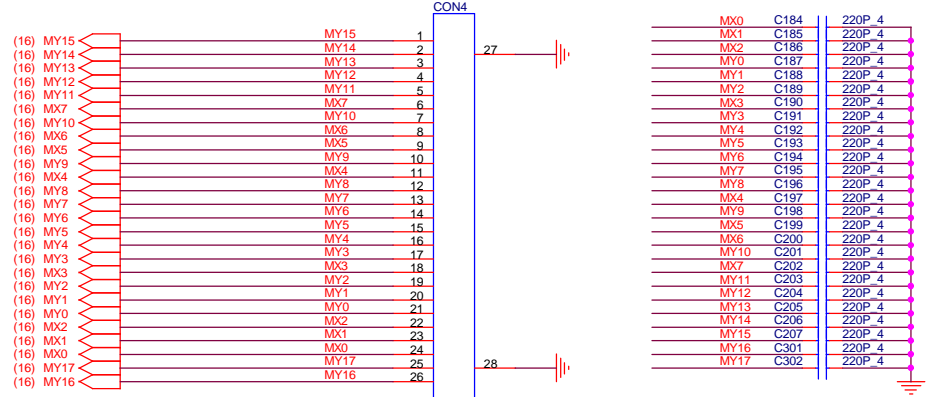

**Quanta Computer Inc.**  
PROJECT :HKC

Size	Document Number	Rev
	<b>HOLE/EMI/KB</b>	1A
Date:	Tuesday, February 05, 2013	Sheet 15 of 40

1.Level 1 Environment-related Substances Should Never be Used.  
2.Recycled Resin and Coated Wire should be procured from Green Partners.







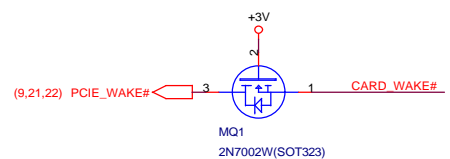
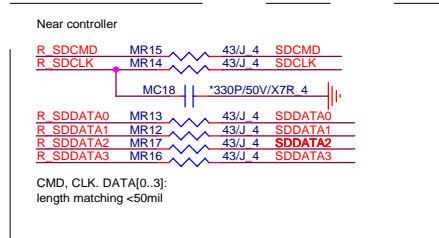
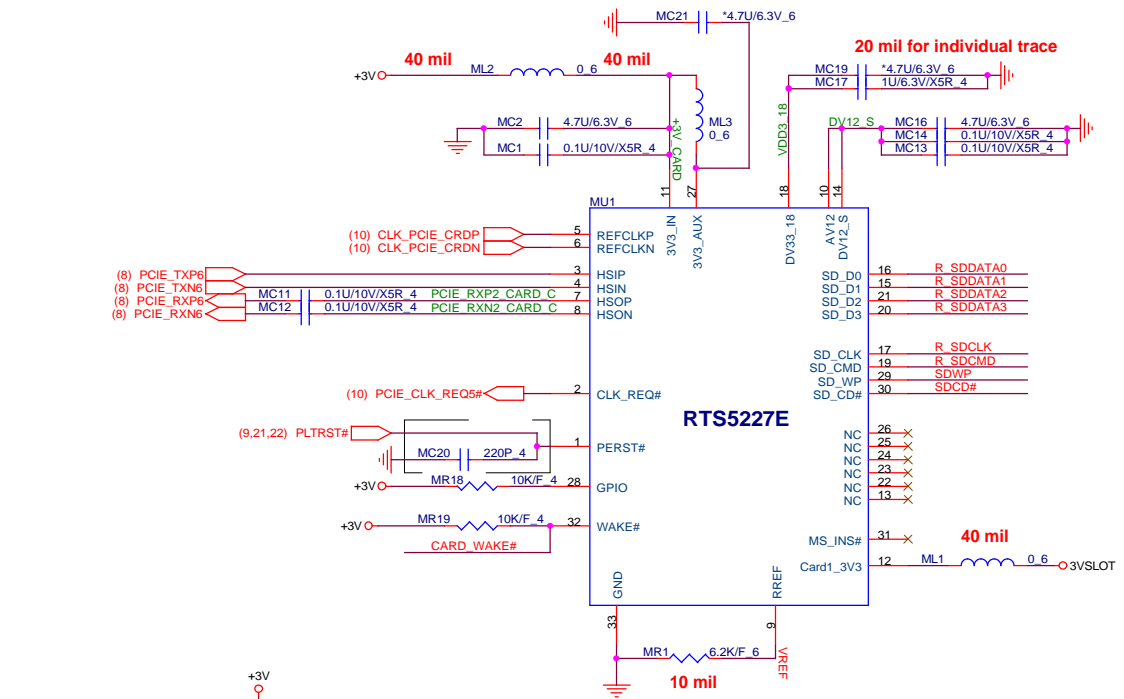

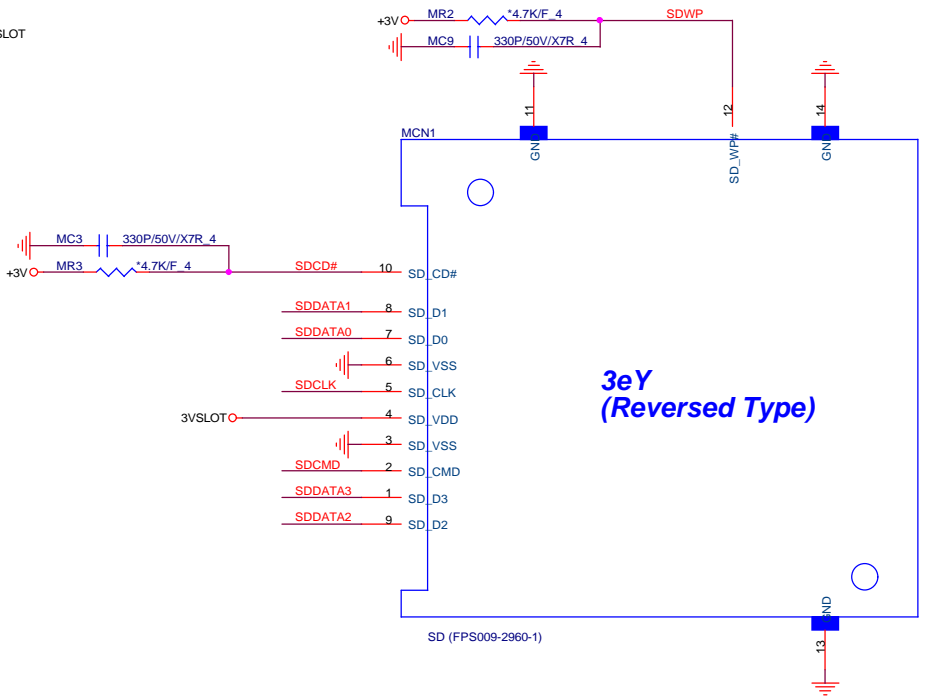
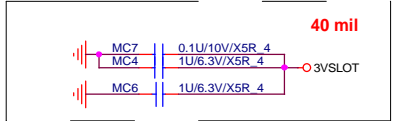

These component need to close to Slot



3eY (Reversed Type)

**Quanta Computer Inc.**  
 PROJECT : HKC  
 Size Document Number  
**CARD**  
 Date: Thursday, January 24, 2013 Sheet 18 of 40 Rev 1A

1. Level 1 Environment-related Substances Should Never be Used.  
 2. Recycled Resin and Coated Wire should be procured from Green Partners.

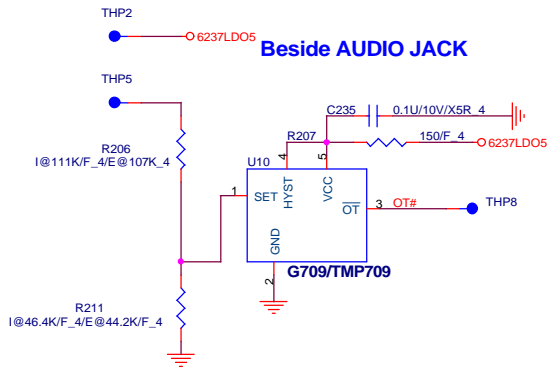
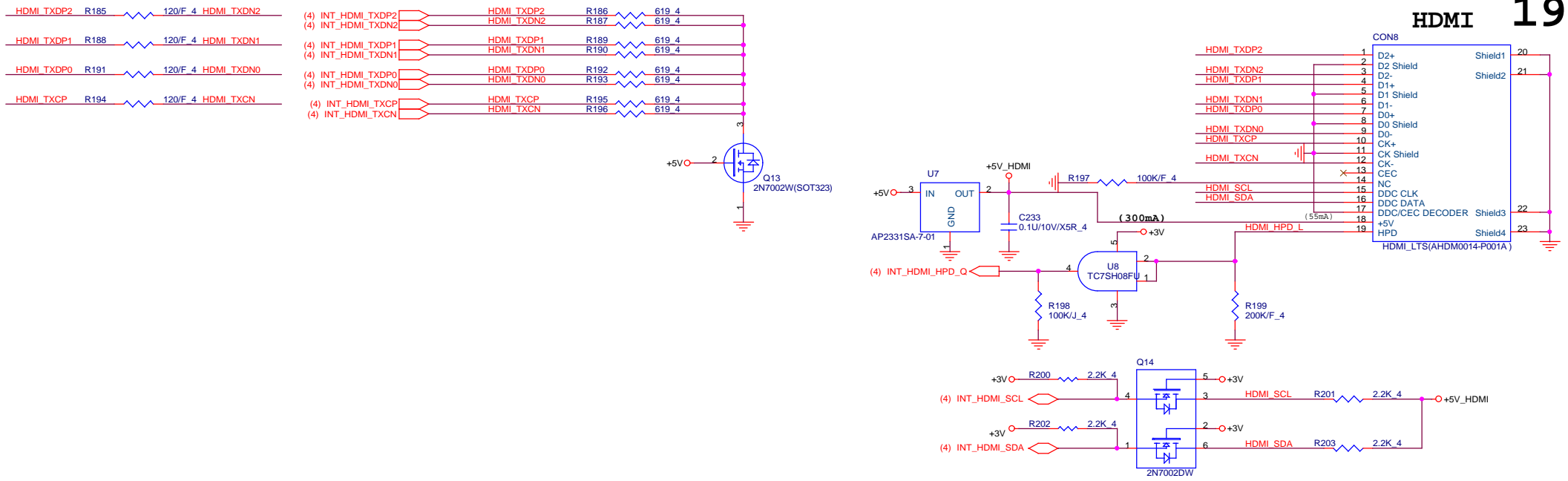

### H/W Thermal Protect

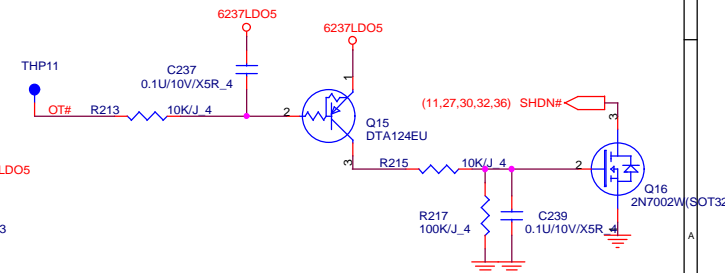
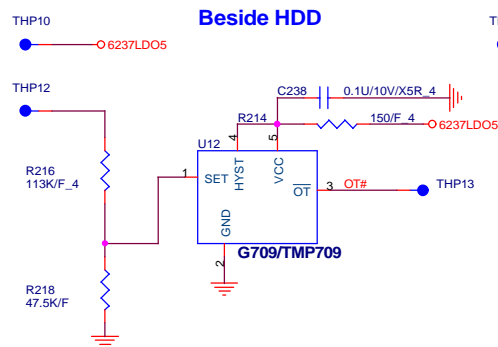
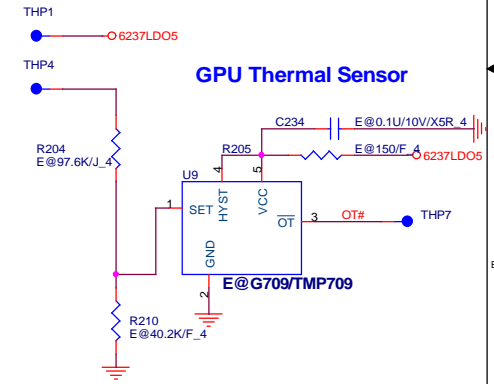
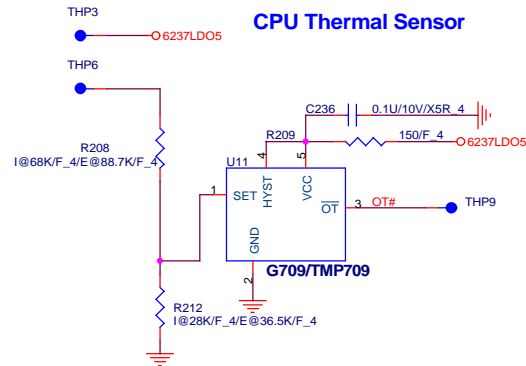

$$RSET(k\Omega) = 0.0012T^2 - 0.9308T + 96.147$$

95	18.5K
100	15K
107	10.3K
110	8.2K

#### DIS SKU

Location of IC	Temp	R-Set	Parts in BOM	Max	Min
Near CPU sensor temp	70	R208=36.87K	36.5K	71	70
Near GFX sensor temp	65	R146=40.72K	40.2K	66.3	65.1
Near AUDIO sensor temp	60	R345=44.62K	44.2K	61.2	60

#### UMA SKU

Location of IC	Temp	R-Set	Parts in BOM	Max	Min
Near CPU sensor temp	81	R208=28.63K	28K	82.3	81.4
Near AUDIO sensor temp	58	R345=46.2K	46.4K	58.4	57.1

**Quanta Computer Inc.**  
PROJECT : HKC

Size	Document Number	Rev
	<b>HDMI/Thermal IC</b>	1A

1. Level 1 Environment-related Substances Should Never be Used.

2. Recycled Resin and Coated Wire should be procured from Green Partners. Date: Thursday, January 31, 2013 Sheet 19 of 40

# MB to USB board

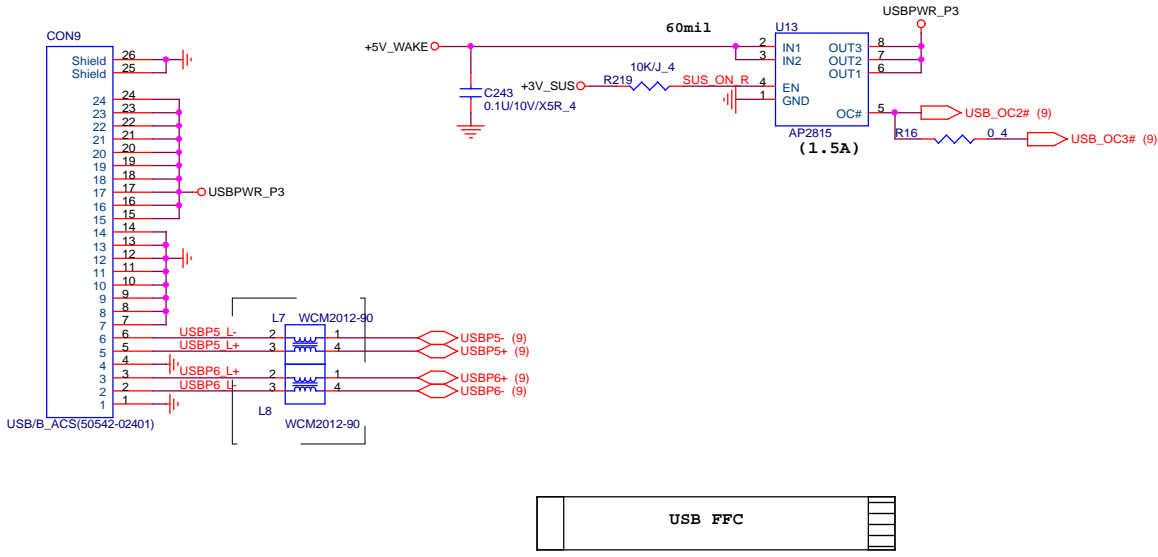

# USB 3.0 PORT1

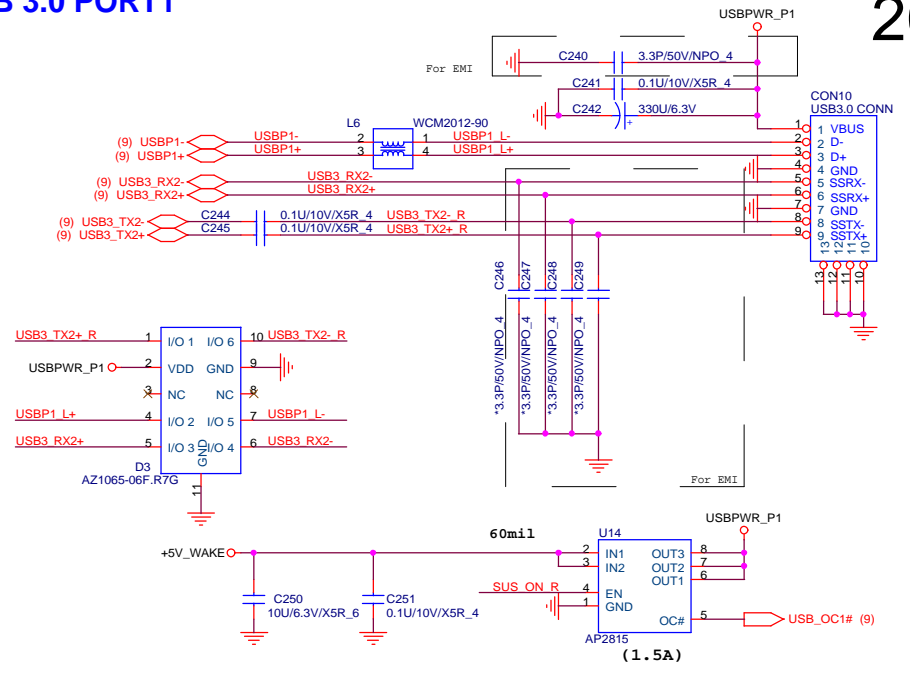

	TPS2540A		TPS2543	
ILIM_SEL	Pin15	Pin16	Pin15	Pin16
High	V			V
Low		V	V	

SDP : Standard Downstream Port  
 CDP : Charging downstream port  
 DCP : Dedicated Charging Port  
 Enable/Disable : setting by BIOS

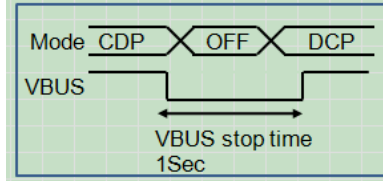

# USB Charger

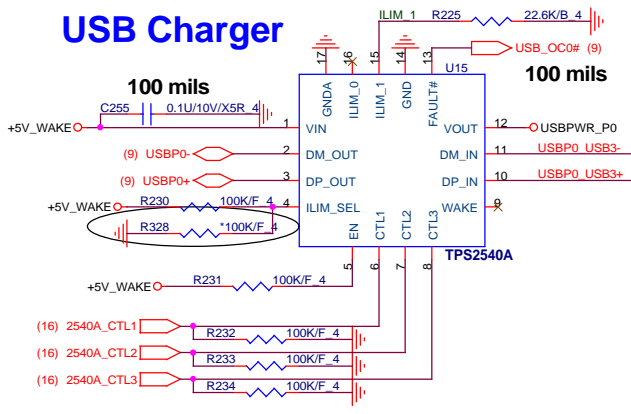

# USB 3.0 PORT0

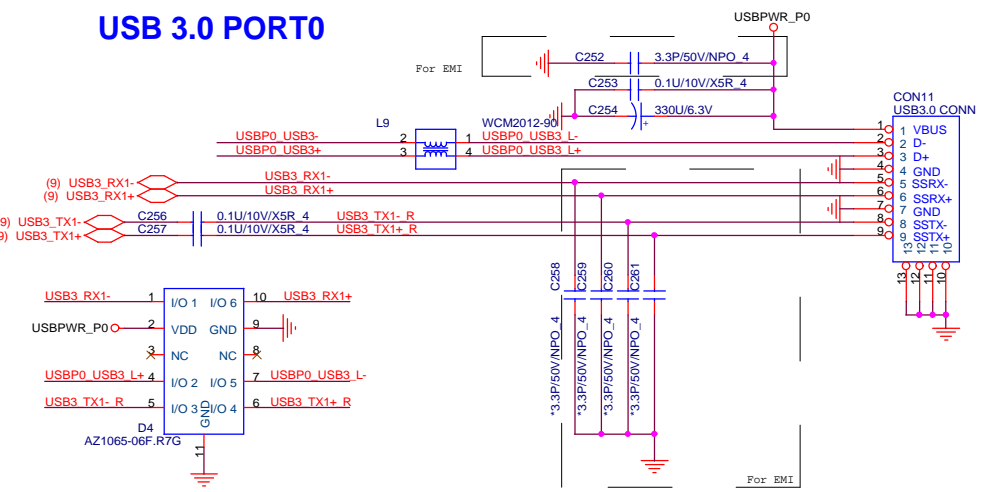

CTL_1	CTL_2	CTL_3	TPS 2540A/2543 Truth Table
0	0	0	OUT discharge, power switch OFF
0	X	1	DCP, Auto-detect(S3/S4/S5, 1.5A)
X	1	0	SDP, USB2.0 mode(S0, 0.5A)
1	0	0	DCP, BC SPEC1.2 only(S3/Deep standby/S4/S5, 1.5A)
1	0	1	DCP, Divider mode only(S3/S4/S5, 1.5A)
1	1	1	CDP (S0, 1.5A)

System State	USB Battery Charging Setting			
	Disable	C(1 2 3)	Enable	C(1 2 3)
S0	Disable	(X 1 0)	Enable	(1 1 1)
S3	SDP	(X 1 0)	DCP BC	(1 0 0)
DS3	Charger OFF	(0 0 0)	DCP BC	(1 0 0)
S4	Charger OFF	(0 0 0)	DCP BC	(1 0 0)
S5	Charger OFF	(0 0 0)	DCP BC	(1 0 0)

ILIM_SEL (I LIMIT(A)= 48000/R)		
HI	I_LIM_1	
LO	I_LIM_0	48000/22.6K=2.123A

**Quanta Computer Inc.**  
 PROJECT : HKC  
**USB/USB Charger**

Size: Document Number  
 Date: Thursday, January 31, 2013  
 Sheet 20 of 40  
 Rev 1A

1. Level 1 Environment-Related Substances should Never be Used.  
 2. Recycled Resin and Coated Wire should be procured from Green Partners.

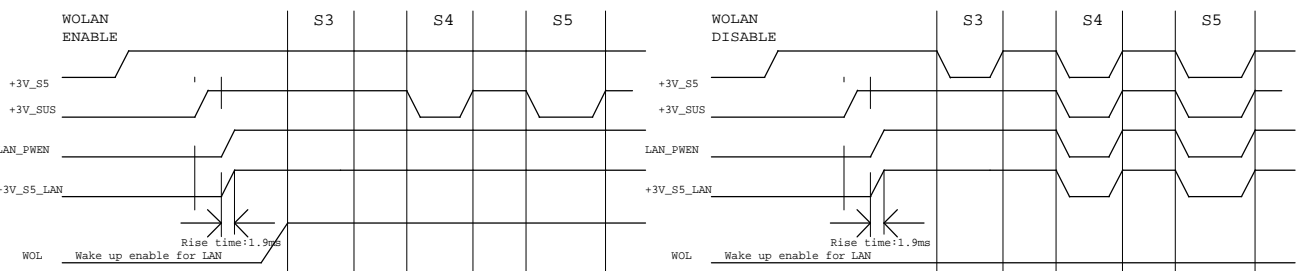
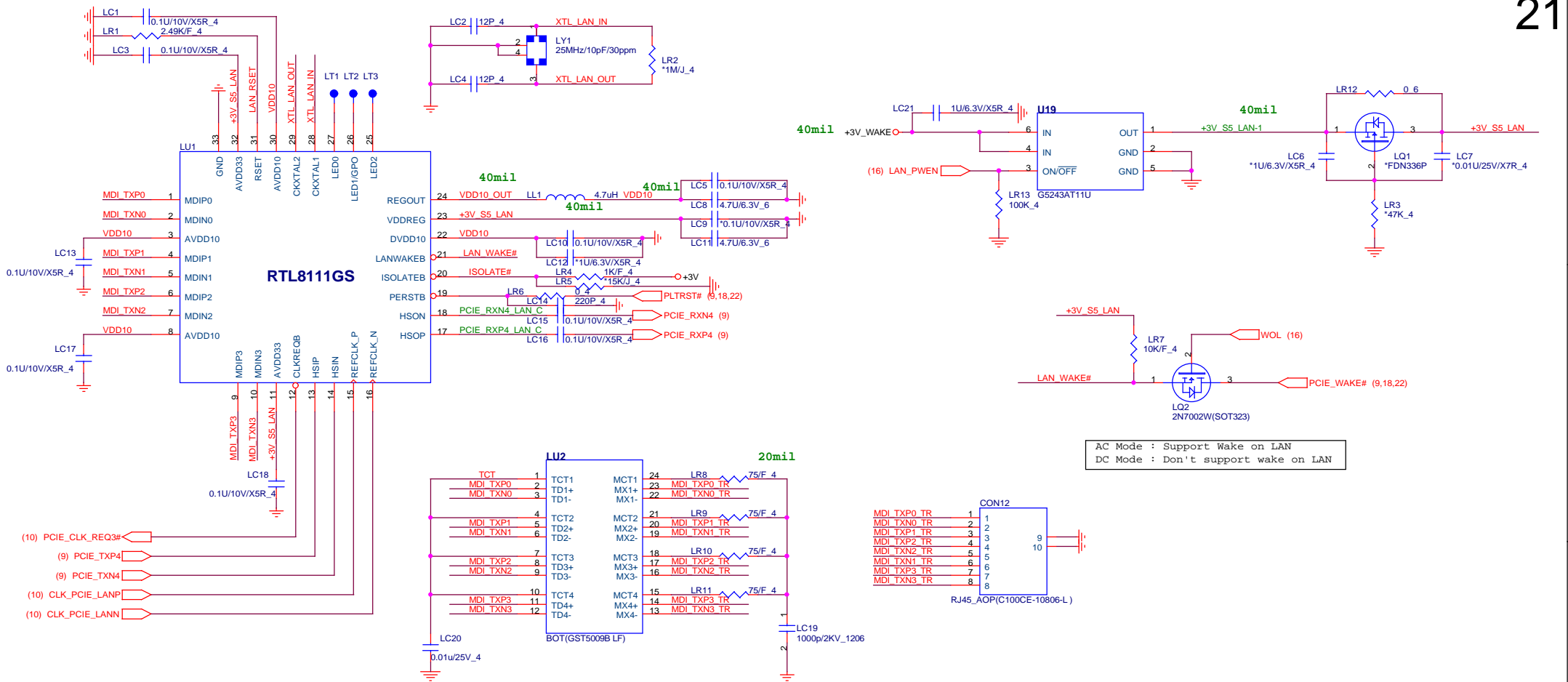

BIOS Setup	WOLAN DISABLE		WOLAN ENABLE	
	LAN_PWEN	WOL	LAN_PWEN	WOL
S3	H	H	H	H
S4	L	L	H	H
S5	L	L	H	H

**Quanta Computer Inc.**  
PROJECT : HKC

Size	Document Number	Rev
	<b>Giga LAN RTL8111GS</b>	1A

Date: Friday, January 25, 2013 Sheet 21 of 40

1.Level 1 Environment-related Substances Should Never be Used.  
2.Recycled Resin and Coated Wire should be procured from Green Partners.



### ODD CONNECTOR

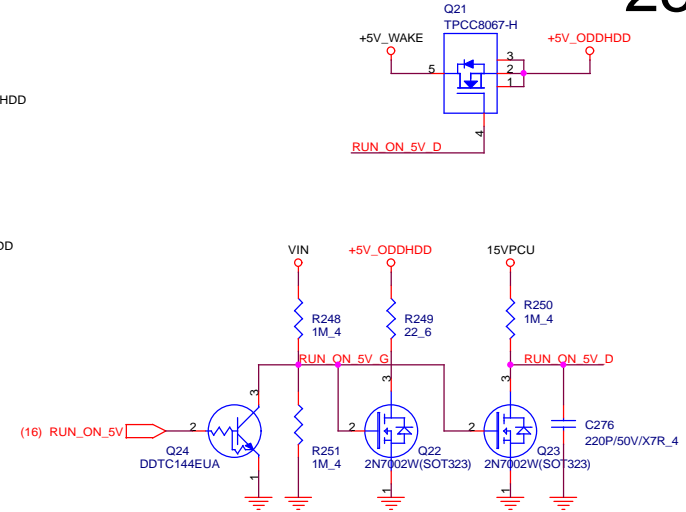
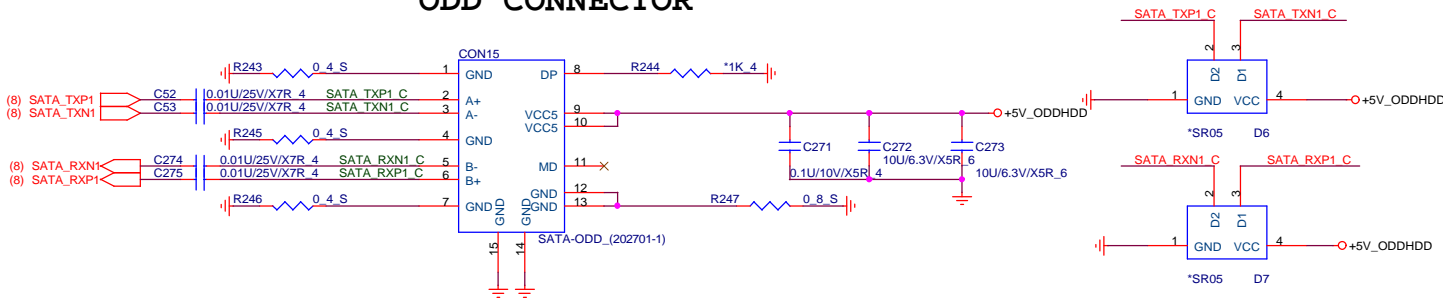

### HDD CONNECTOR

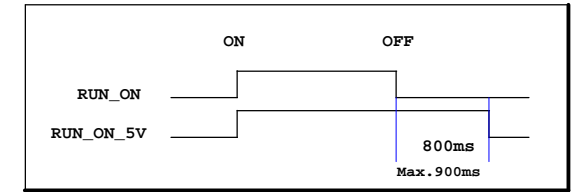
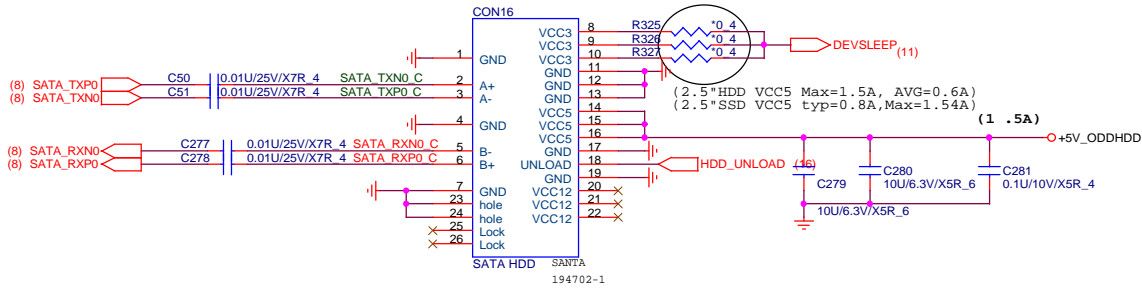

### HDD PROTECT SPI INTERFACE

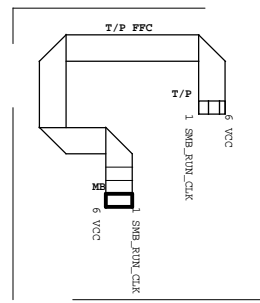
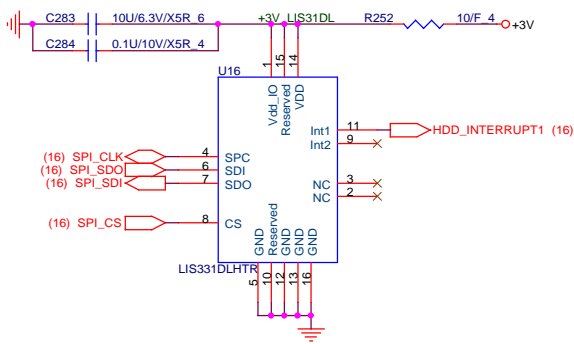

### T/P Board to T/P

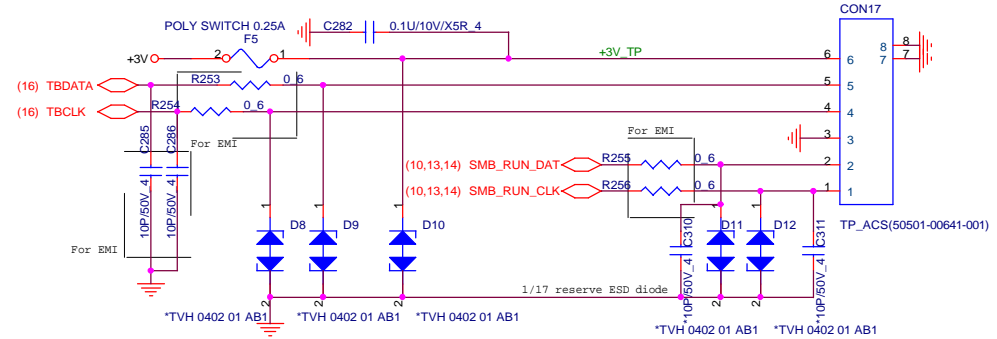

### FAN

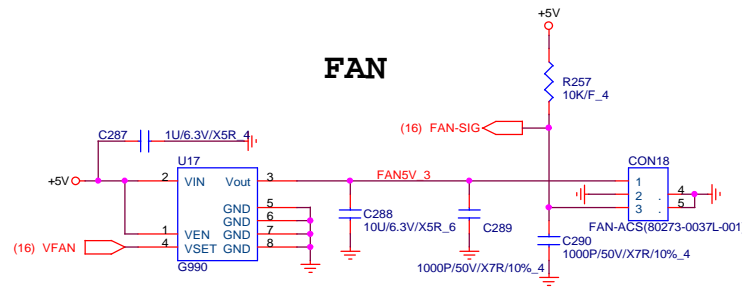

**Quanta Computer Inc.**  
PROJECT : HKC

Size	Document Number	Rev
	<b>HDD/ODD/TP/FAN</b>	1A

Date: Thursday, January 31, 2013 Sheet 23 of 40

1. Level 1 Environment-related Substances Should Never be Used.  
2. Recycled Resin and Coated Wire should be procured from Green Partners.





Camera

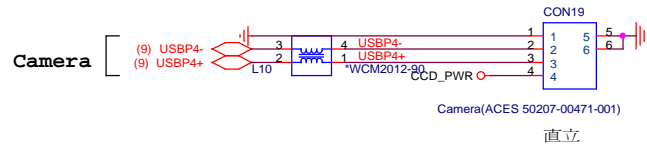
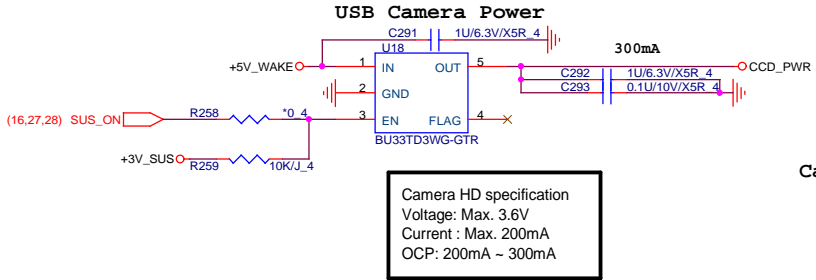

SATA LED

BATTERY LED

Power/Sleep LED

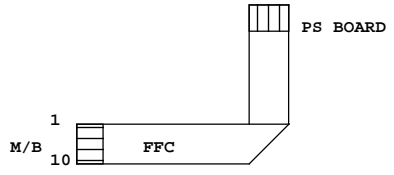
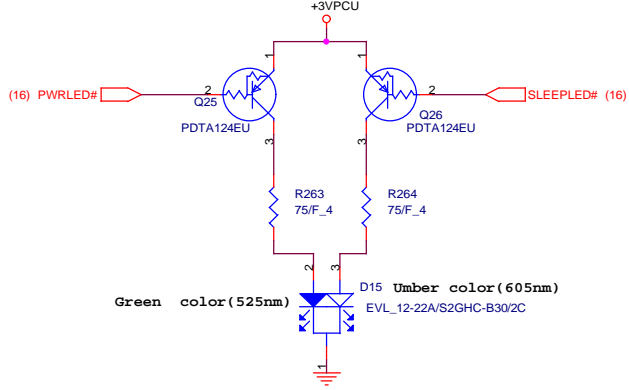
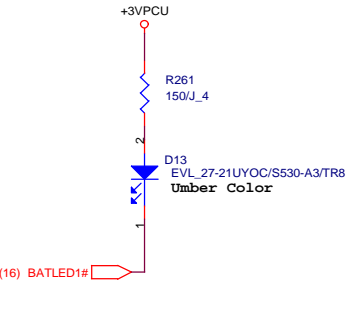
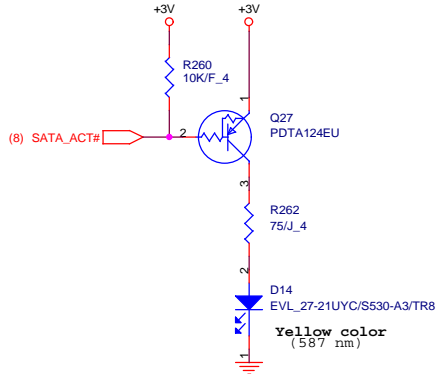

Power SW Board Connector

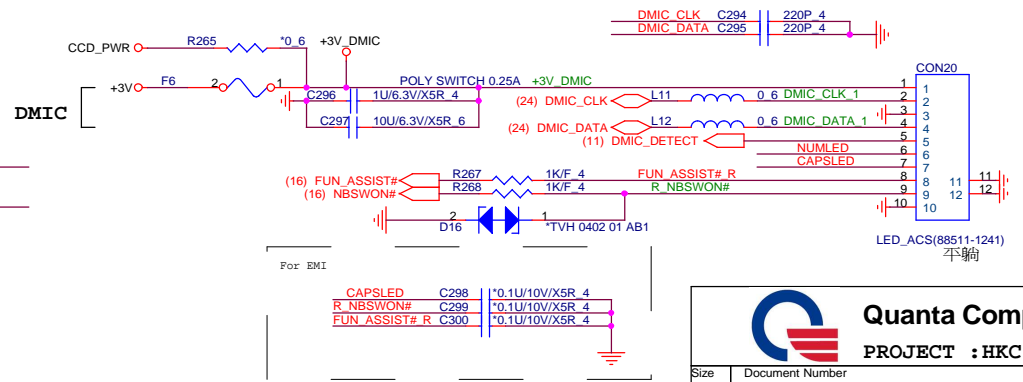
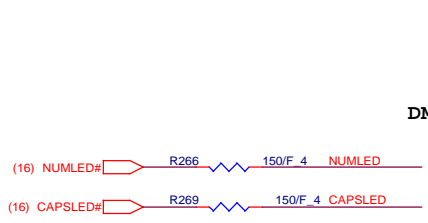

**Quanta Computer Inc.**  
PROJECT : HKC

Size	Document Number	Rev
	<b>LED/RF/KB/PS</b>	1A
Date:	Thursday, January 24, 2013	Sheet 25 of 40

1. Level 1 Environment-related Substances Should Never be Used.  
2. Recycled Resin and Coated Wire should be procured from Green Partners.

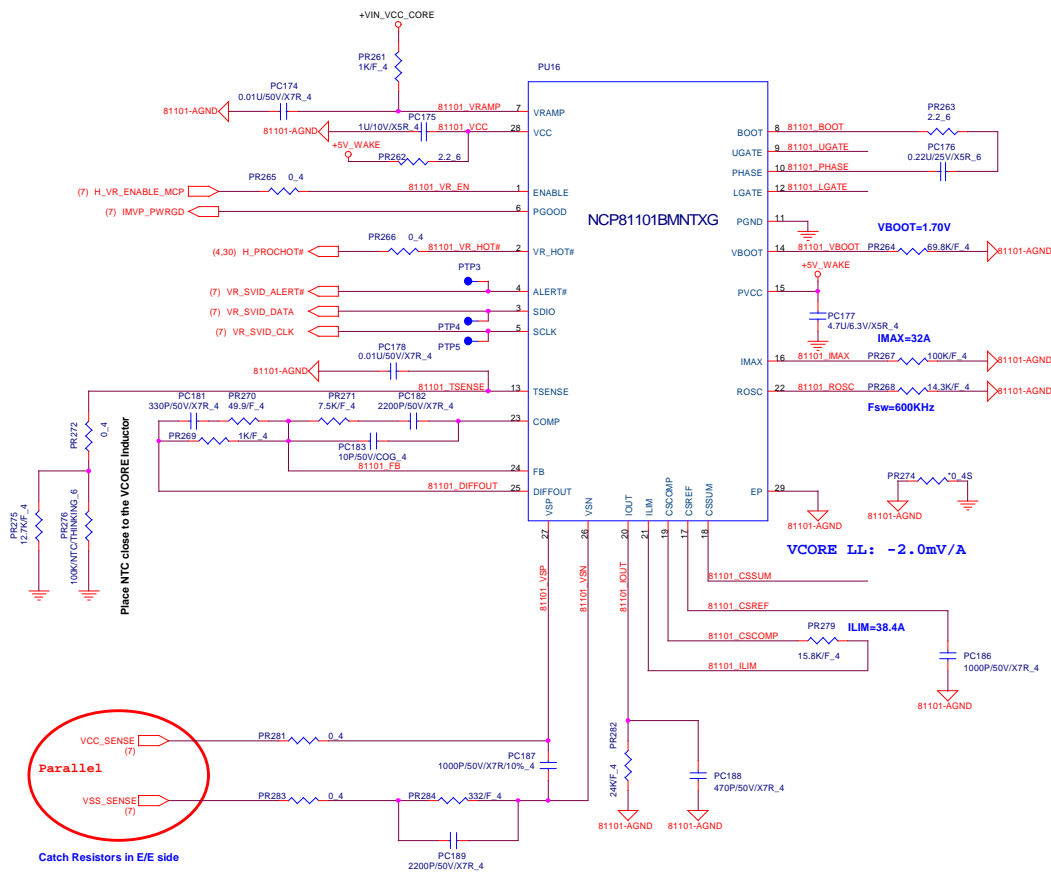

1. Level 1 Environment-related Substances should Never be Used.  
 2. Recycled Resin and Coated Wire should be procured from Green Partners.



# 1.5VSUS & VTT\_MEM

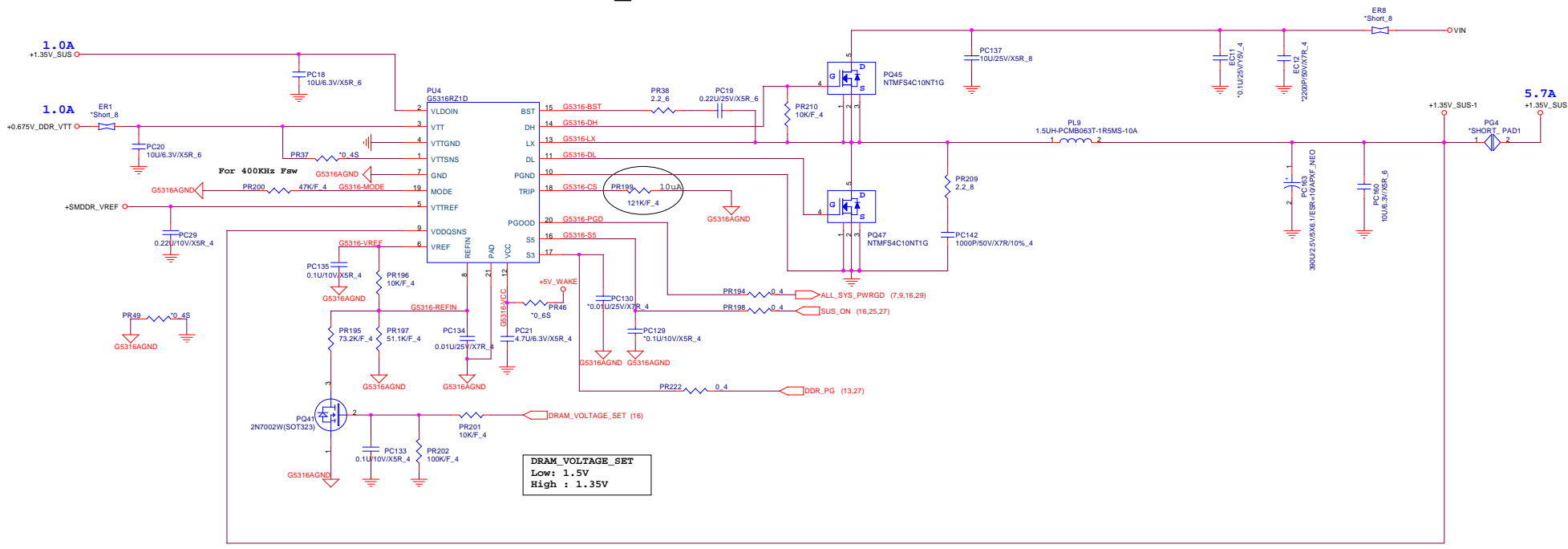

MODE	Resistor on Mode	Fsw	Discharge Mode
3	200Kohm	400KHz	Tracking discharge
2	100Kohm	300KHz	Tracking discharge
1	68Kohm	300KHz	Non-tracking discharge
0	47Kohm	400KHz	Non-tracking discharge

STATE	S3	S5	1.5VSUS	VTTREF	VTT
S0	1	1	On	On	On
S3	0	1	On	On	Off/High Z
S4/S5	0	0	Off	Off	Off

**Quanta Computer Inc.**  
 PROJECT : HKC

Size	Document Number	Rev
	1.5VSUS/VTT_MEM	1A

1. Level 1 Environment-related Substances should Never be Used.  
 2. Recycled Resin and Coated Wire should be procured from Green Partners.

Date: Thursday, January 24, 2013 Sheet 28 of 40



VCC1.5

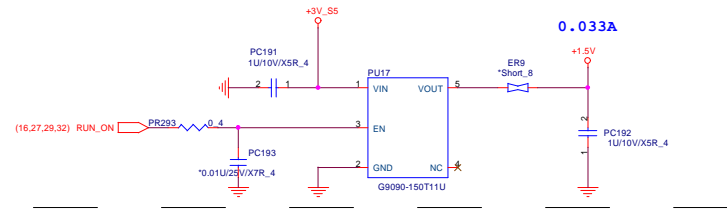

One-Shot 10ms PROCHOT# For ADP/BAT

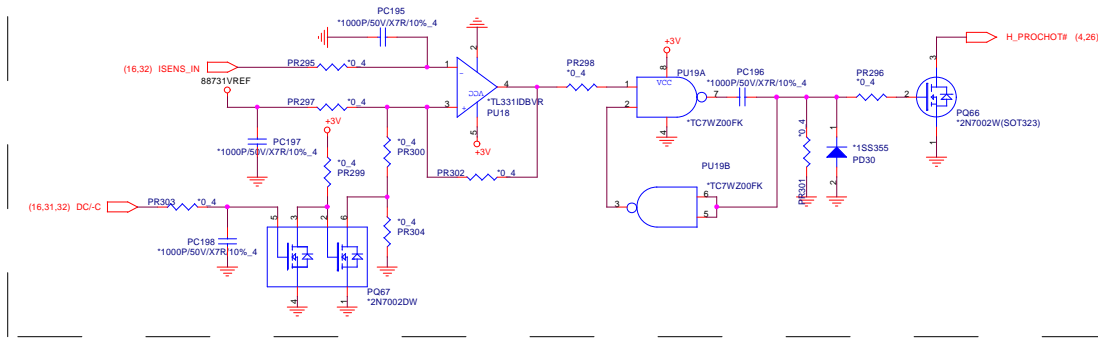

Thermal Protection and Battery UVP for VEDS

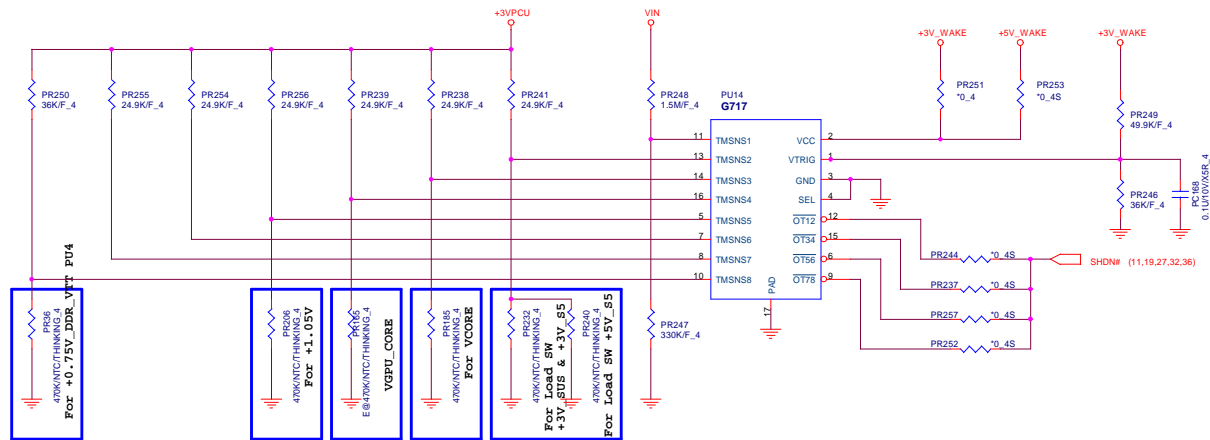

1. Level 1 Environment-related Substances Should Never be Used.  
 2. Recycled Resin and Coated Wire should be procured from Green Partners.











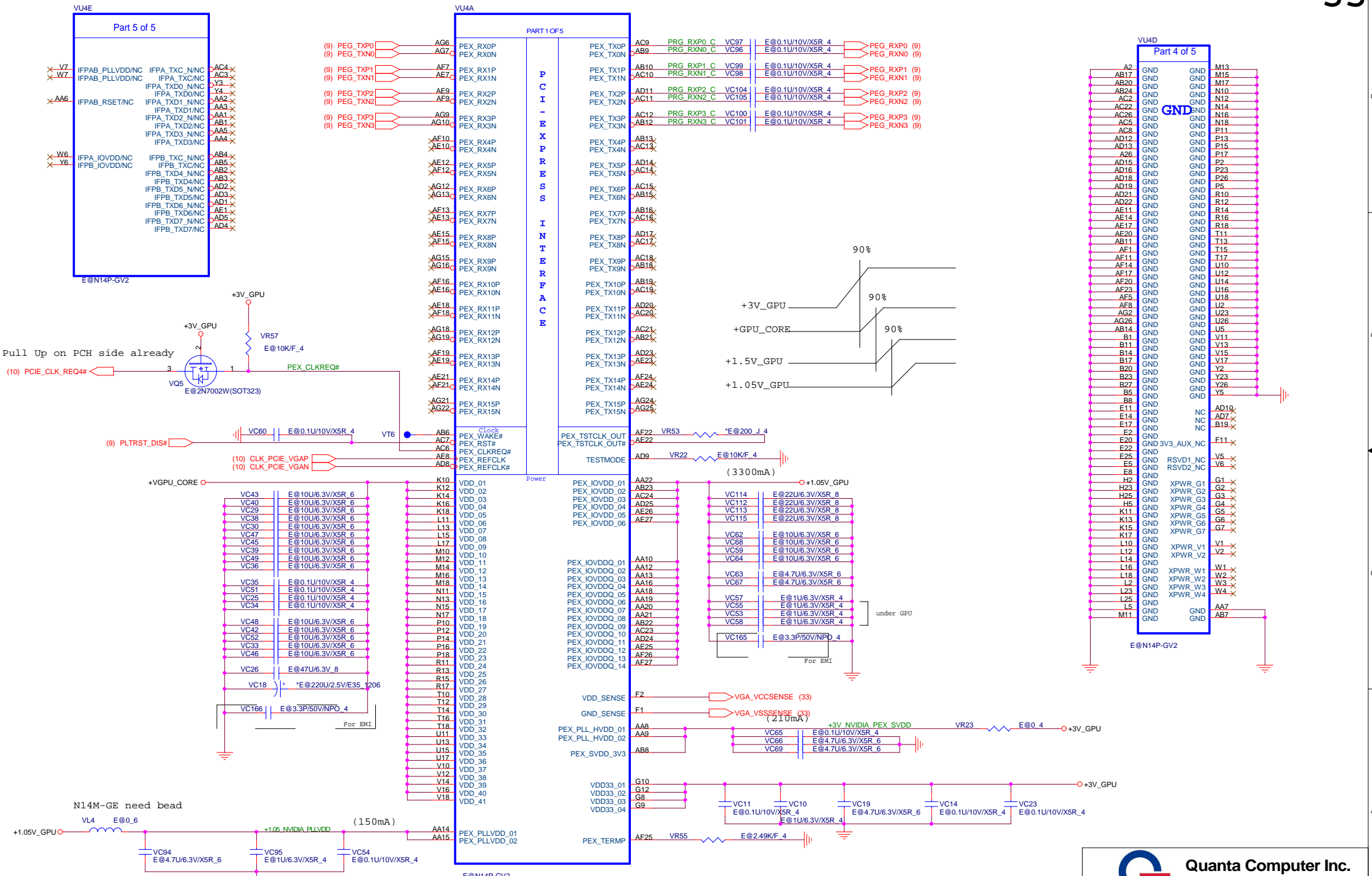

**Quanta Computer Inc.**  
**PROJECT : HKC**

Size: Document Number: **Nvidia 1/4** Rev 1A

1. Level 1 Environment-related Substances Should Never be Used.  
 2. Recycled Resin and Coated Wire should be procured from Green Partners.

Date: Thursday, January 24, 2013 Sheet 35 of 40

For GC6 GPU Monitor Status (FB\_CLAMP\_MON)

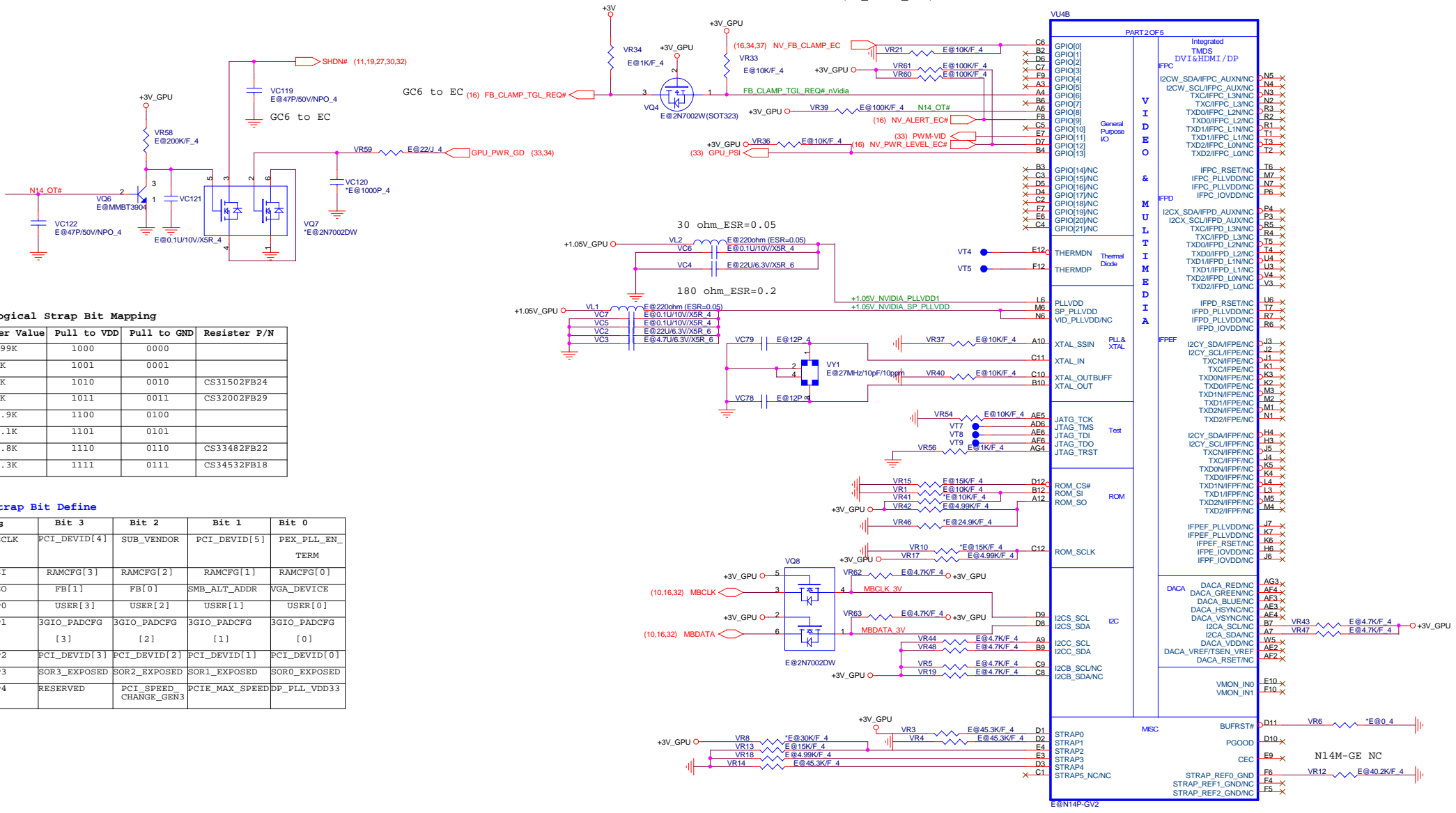

N14 Logical Strap Bit Mapping

Resistor Value	Pull to VDD	Pull to GND	Resistor P/N
4.99K	1000	0000	
10K	1001	0001	
15K	1010	0010	CS31502FB24
20K	1011	0011	CS32002FB29
24.9K	1100	0100	
30.1K	1101	0101	
34.8K	1110	0110	CS33482FB22
45.3K	1111	0111	CS34532FB18

N14 Strap Bit Define

Straps	Bit 3	Bit 2	Bit 1	Bit 0
ROM_SCLK	PCI_DEVID[4]	SUB_VENDOR	PCI_DEVID[5]	PEX_PLL_EN_TERM
ROM_SI	RAMCFG[3]	RAMCFG[2]	RAMCFG[1]	RAMCFG[0]
ROM_SO	FB[1]	FB[0]	SMB_ALT_ADDR	VGA_DEVICE
STRAP0	USER[3]	USER[2]	USER[1]	USER[0]
STRAP1	3GIO_PADCFG [3]	3GIO_PADCFG [2]	3GIO_PADCFG [1]	3GIO_PADCFG [0]
STRAP2	PCI_DEVID[3]	PCI_DEVID[2]	PCI_DEVID[1]	PCI_DEVID[0]
STRAP3	SOR3_EXPOSED	SOR2_EXPOSED	SOR1_EXPOSED	SOR0_EXPOSED
STRAP4	RESERVED	PCI_SPEED_CHANGE_GEN3	PCI_MAX_SPEED	DP_PLL_VDD33

	VRAM Capacity	VRAM Vender	ID	VR1	Mfr P/N	Quanta P/N
N14M-LP	128Mx16 DDR3	Samsung	0111	PD45.3K	K4W2G1646E-BC11	AKD5MGGT525
		Hynix	0110	PD34.8K	H5TQ2G63DFR-11C	AKD5MGWTW15
N14P-GV2	256Mx16 DDR3	Samsung	0011	PD20K	K4W4G1646B-HC11	AKD5MGWT525
		Hynix	0010 (TBD)	PD15K	H5TC4G63AFR-11C	AKD5PGWTW10

1. Level 1 Environment-related Substances Should Never be Used.  
 2. Recycled Resin and Coated Wire should be procured from Green Partners.

**Quanta Computer Inc.**  
 PROJECT : HKC

Size: Document Number: **Nvidia 2/4** Rev: 1A

Date: Thursday, January 24, 2013 Sheet: 36 of 40

Down Side VRAM TOP/BOT

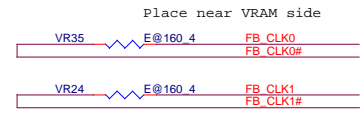
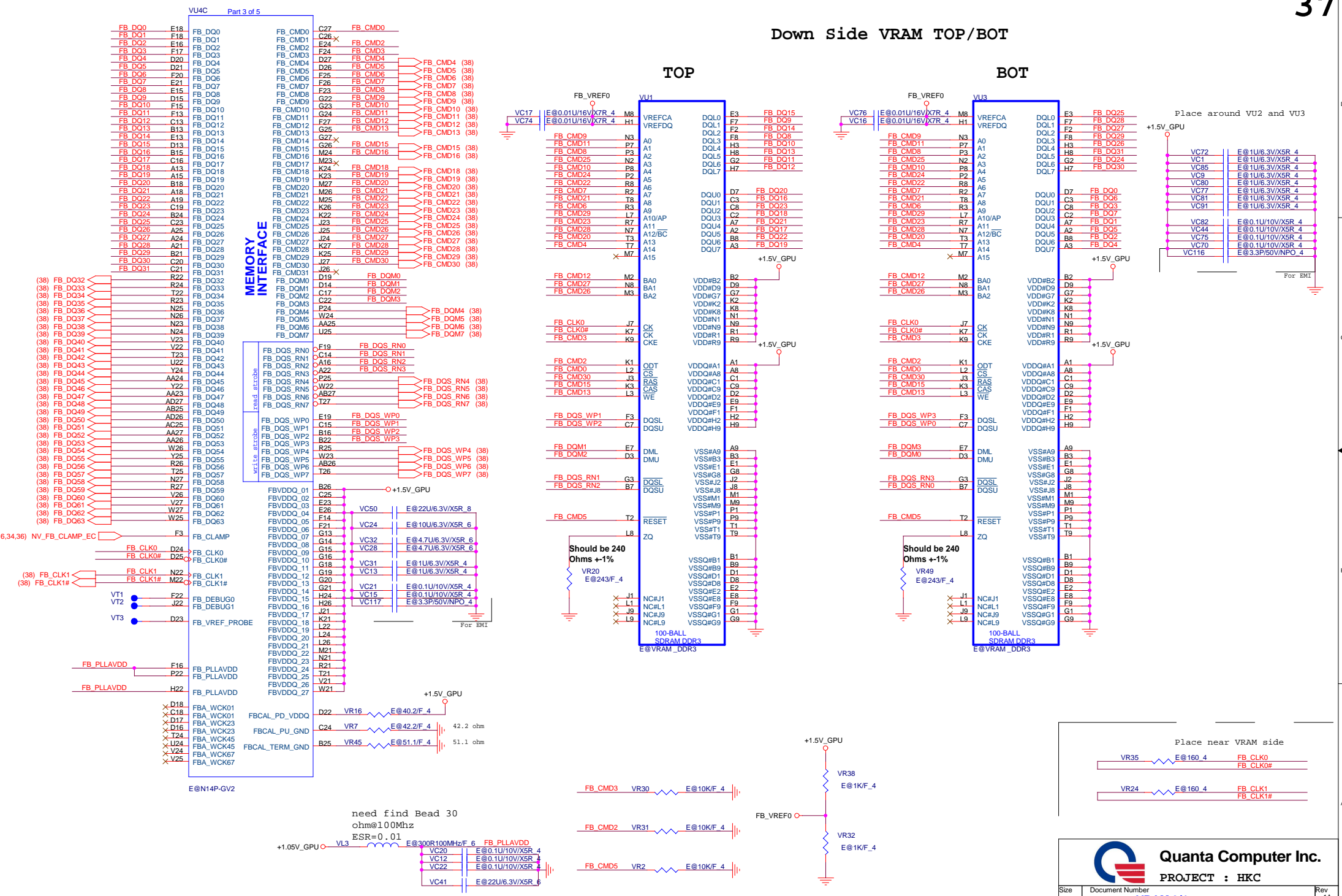

**Quanta Computer Inc.**  
PROJECT : HKC

Size Document Number **VRAM 3/4** Rev 1A

Date: Thursday, January 24, 2013 Sheet 37 of 40

1. Level 1 Environment-related Substances Should Never be Used.  
2. Recycled Resin and Coated Wire should be procured from Green Partners.

Up Side VRAM TOP/BOT

TOP

BOT

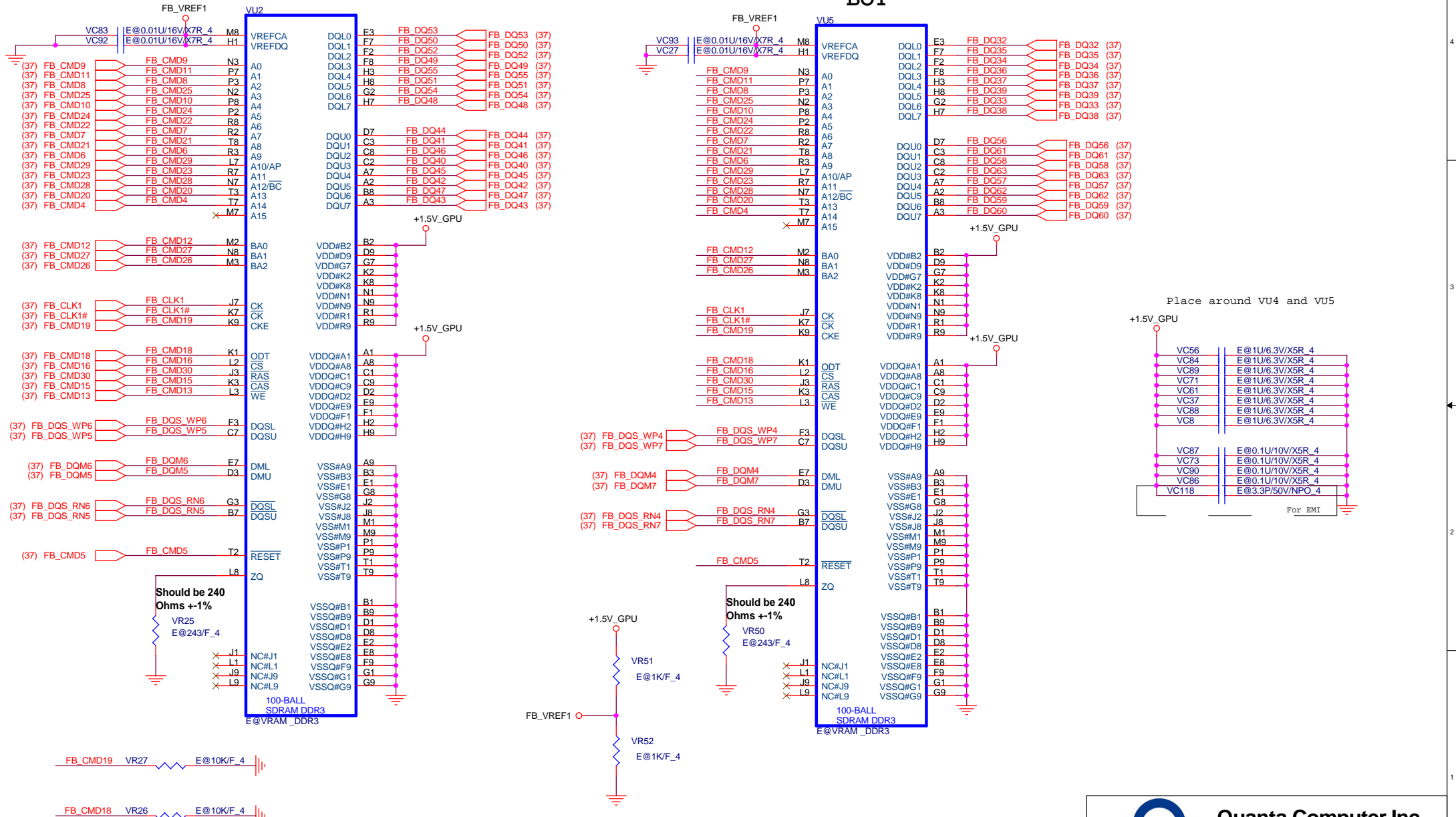

**Quanta Computer Inc.**  
PROJECT : HKC

Size	Document Number	Rev
	VRAM 4/4	1A
Date:	Thursday, January 24, 2013	Sheet 38 of 40

1. Level 1 Environment-related Substances Should Never be Used.  
2. Recycled Resin and Coated Wire should be procured from Green Partners.

Woofers frequency 400Hz

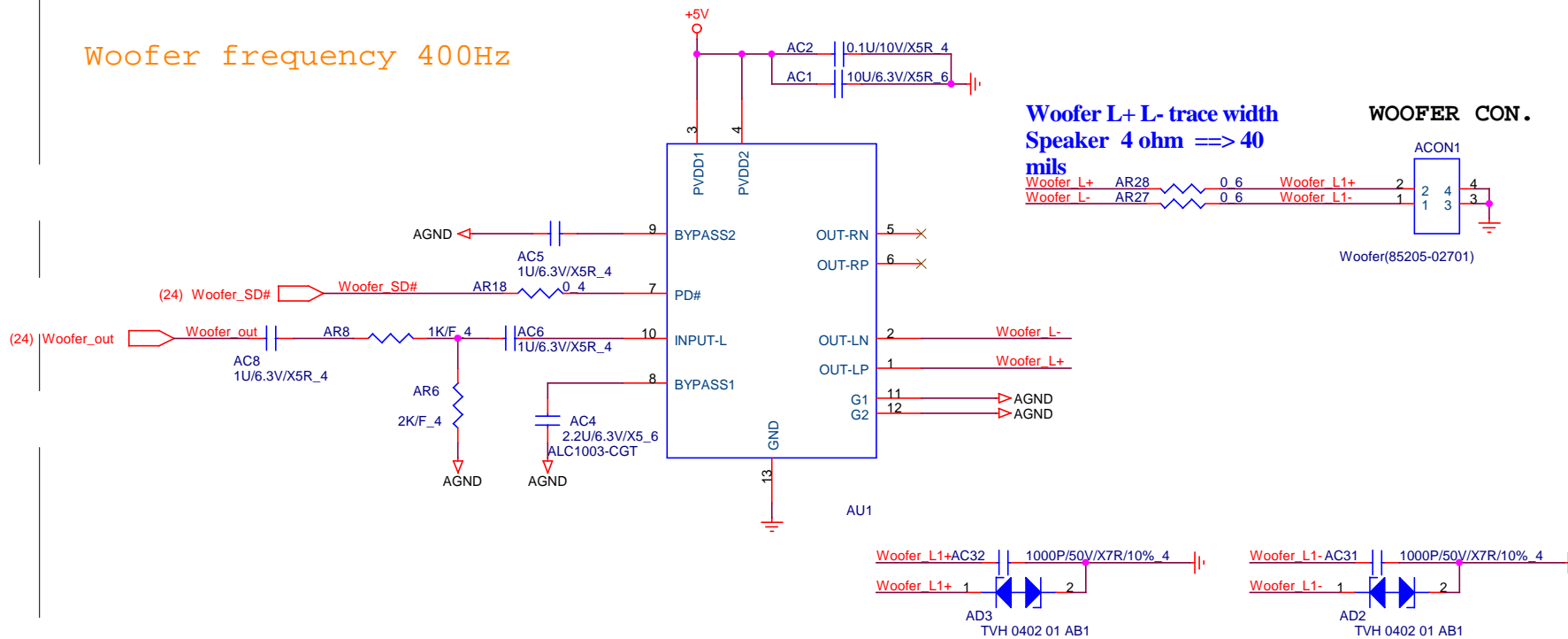

1.Level 1 Environment-related Substances Should Never be Used.  
 2.Recycled Resin and Coated Wire should be procured from Green Partners.

 <b>Quanta Computer Inc.</b> PROJECT : HKC		Size	Document Number	Rev	
		<b>Audio Codec Woofer</b>		1A	
Date:	Thursday, January 24, 2013	Sheet	39	of	40

USB PORT Architecture	
PORT 0	USB3.0
PORT 1	USN3.0
PORT 2	USN2.0
PORT 3	USB2.0
PORT 4	NFC
PORT 5	N/A
PORT 6	N/A
PORT 7	N/A
PORT 8	N/A
PORT 9	WiMax/BT
PORT 10	Camera
PORT 11	Card Reader
PORT 12	Touch Screen
PORT 13	N/A

PCIE BUS	
PORT 1	WLAN Port
PORT 2	CARD READER
PORT 3	GLAN(RTL8111G)
PORT 4	N/A
PORT 5	N/A
PORT 6	N/A
PORT 7	N/A
PORT 8	N/A

SATA BUS	
PORT 0	HDD
PORT 1	N/A
PORT 2	N/A
PORT 3	N/A
PORT 4	ODD
PORT 5	N/A

SM BUS	MBCLK/MBDATA	WRITE	READ	Function
ISL88731CHRTZ	0001 001X	0001 0010	0001 0011	Charger
Nvidia	1001 1110	-	1001 1110	Graphice
LIS331DL	0011 101X	0011 1010	0011 1011	G Sensor

SM BUS	MBCLK_BAT/MBDATA_BAT	WRITE	READ	Function
VGP-BPS35A	0001 011X	0001 0110	0001 0111	Battery

SM BUS	SMB_PCH_CLK/SMB_PCH_DAT	WRITE	READ	Function
DIMM Module0	1010 000X	1010 0000	1010 0001	DDRIII
DIMM Module 1	1010 010X	1010 0100	1010 0101	DDRIII
Synaptics	0010 110X	0010 1100	0010 1101	Click PAD

	R363(High) R362(Low)	R294(High) R297(low)
Board ID3	0	0
Board ID0	0	1
14"/HK6	0	0
15"/HK5	0	1
17"/HK7	1	0

Board ID1 (VRAM Vendor)	Samaung(1)	Hynix(0)
R47(High)	Stuff	No Stuff
R48(Low)	No Stuff	Stuff

Board ID2		
14" 4PCS	1G	512M
15" 8PCS	1G	2G

R39(High)	Stuff	No Stuff
R27(Low)	No Stuff	Stuff

PCBA SKU	Discrete	UMA
R277(Pull High)	Stuff	No Stuff
R275(Pull Low)	No Stuff	Stuff

OS status	S0	S3	DS3	(Soft OFF)	(Soft OFF)	(Soft OFF)	(Soft OFF)	(Soft OFF)
H/W status	S0	S3	DS3	S4 (Win8 off) RTC wake Enable WOLAN Enable	S4 (Win8 off) RTC wake Disable WOLAN Disable	S5 Charge Enable	S5 Charge Disable WoL Disable	S5 WoL Enable
<b>RUN_ON</b>	H	L	L	L	L	L	L	L
+3V	H	L	L	L	L	L	L	L
+5V	H	L	L	L	L	L	L	L
+0.675V_DDR_VTT	H	L	L	L	L	L	L	L
+1.05V	H	L	L	L	L	L	L	L
+0.85V	H	L	L	L	L	L	L	L
+1.5V	H	L	L	L	L	L	L	L
+3V_GPU	H	L	L	L	L	L	L	L
+1.05V_GPU	H	L	L	L	L	L	L	L
+VGPU_CORE	H	L	L	L	L	L	L	L
+VCC_CORE	H	L	L	L	L	L	L	L
<b>SUS_ON</b>	H	H	H	L	L	L	L	L
+1.35V_SUS	H	H	H	L	L	L	L	L
<b>S5_ON</b>	H	H	L	H	L	L	L	H
+5V_S5	H	H	L	H	L	L	L	H
+3V_S5	H	H	L	H	L	L	L	H
<b>EC_WAKE_ON</b>	H	H	H	H	L	H	L	H
+3V_WAKE	H	H	H	H	L	H	L	H
+5V_WAKE	H	H	H	H	L	H	L	H
<b>DEEP_EC_EN</b>	H	H	H	H	L	L	L	L
+3V_S5_DSW	H	H	H	H	L	L	L	L
+3V_SUS	H	H	L	L	L	L	L	L