

QL6 BLOCK DIAGRAM

- LAYER 1 : TOP
- LAYER 2 : SGND
- LAYER 3 : IN1
- LAYER 4 : SGND
- LAYER 5 : SVCC
- LAYER 6 : IN2
- LAYER 7 : SGND
- LAYER 8 : BOT

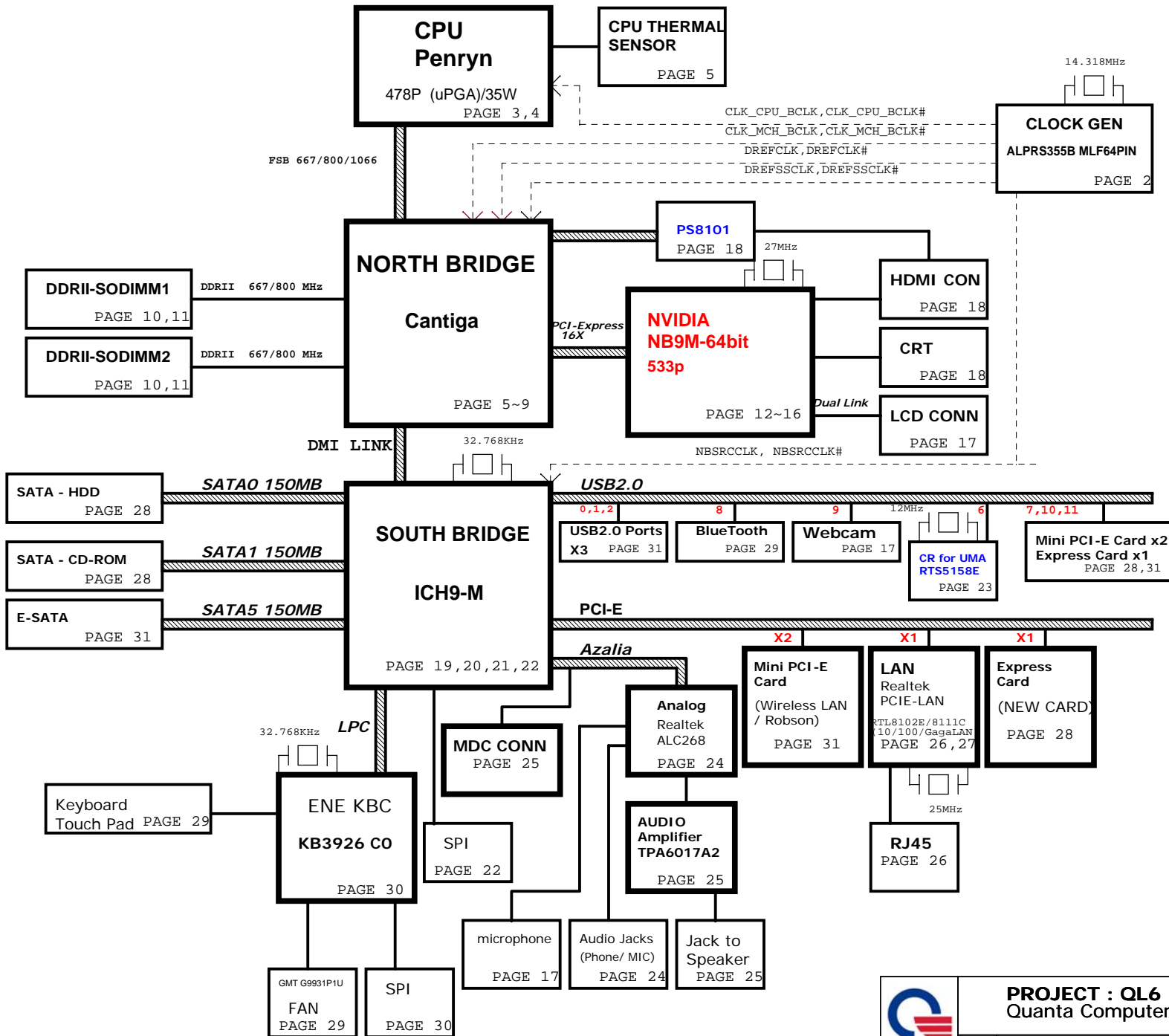

- SYSTEM CHARGER(ISL6251AHAZ-T) PAGE 32
- SYSTEM POWER ISL6237IRZ-T PAGE 33
- DDR II SMDR_VTERM 1.8V/1.8VSUS(TPSS51116REGR) PAGE 37
- VCCP +1.5V AND GMCH 1.05V(RT8204) PAGE 34
- VGACORE(1.025V)Oz8118 PAGE 36
- CPU CORE ISL6266A PAGE 35

	PROJECT : QL6		Date: Tuesday, February 26, 2008 Sheet 1 of 40
	Quanta Computer Inc.		
	Size Custom	Document Number	
		Block Diagram	

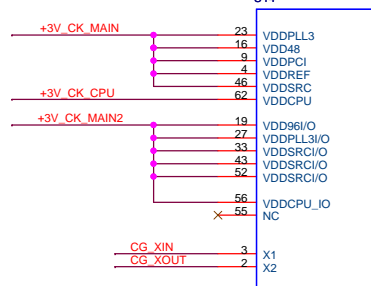
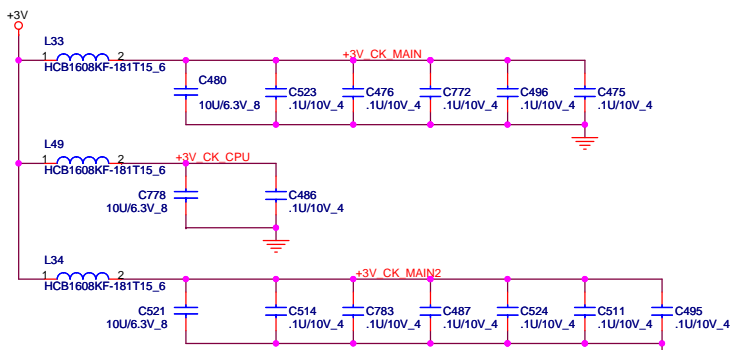

CK505

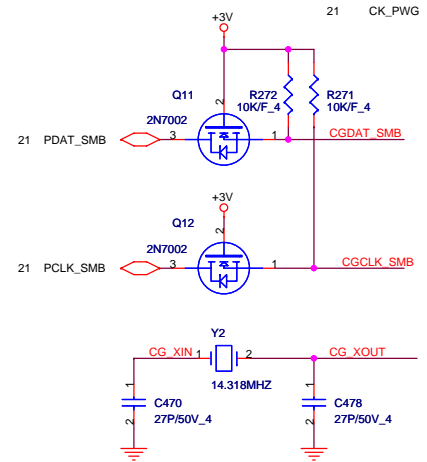
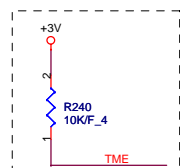
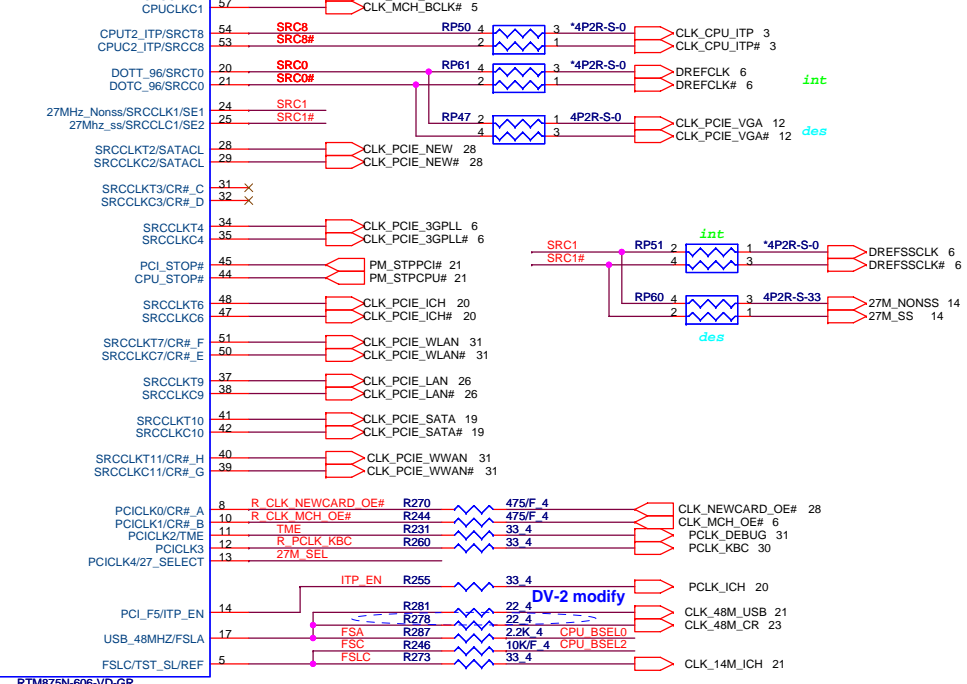

0=overclocking of CPU and SRC Allowed
 1 = overclocking of CPU and SRC not Allowed

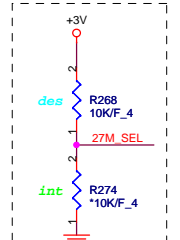

0=UMA
 1 = External VGA

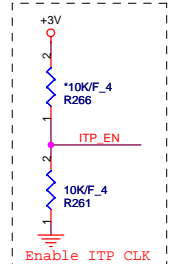

27M_SEL PIN13	PIN20	PIN21	PIN24	PIN25
0=UMA	DOT96T	DOT96C	SRCT1/LCDDT_100	SRCT1/LCDDT_100
1 = External VGA	SRCT0	SRCC0	27Mout-NSS	27Mout-SS

CK505 QFN64

ICS ICS9LPRS355BKLF ALPRS355000
 Silego SLG8SP513VTR AL8SP513000
 Realtek RTM875N-606-VD-GR AL000875000

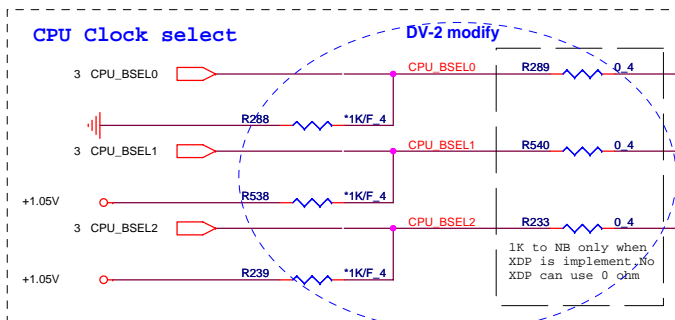
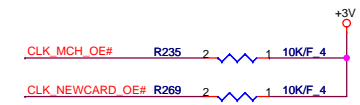

FSC	FSB	FSA	CPU	SRC	PCI
1	0	1	100	100	33
0	0	1	133	100	33
0	1	1	166	100	33
0	1	0	200	100	33
0	0	0	266	100	33
1	0	0	333	100	33
1	1	0	400	100	33
1	1	1	RSVD	100	33

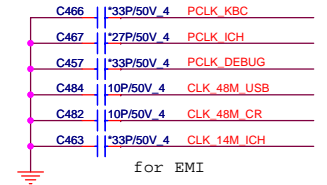

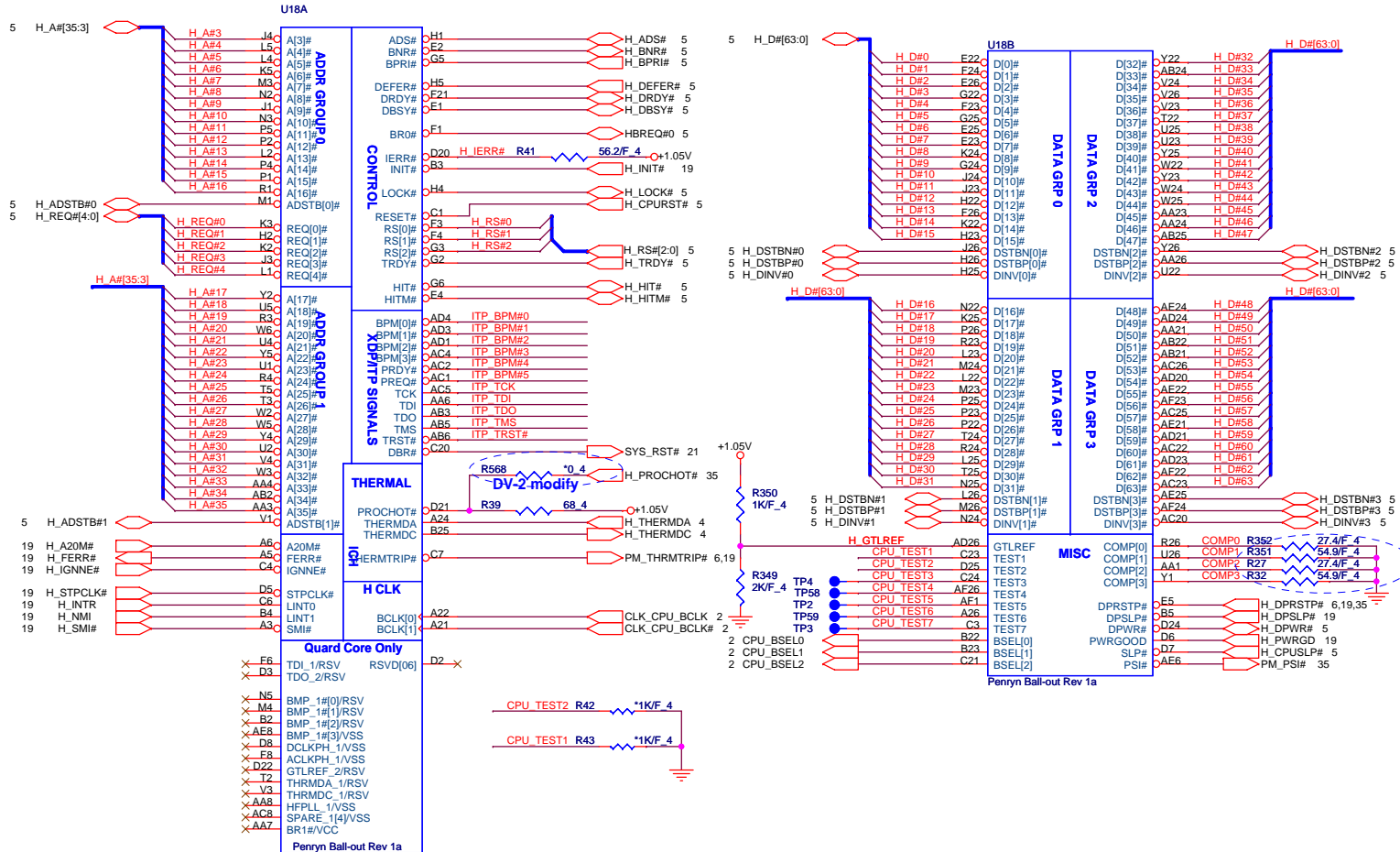

DV-2 modify

DV-2 modify

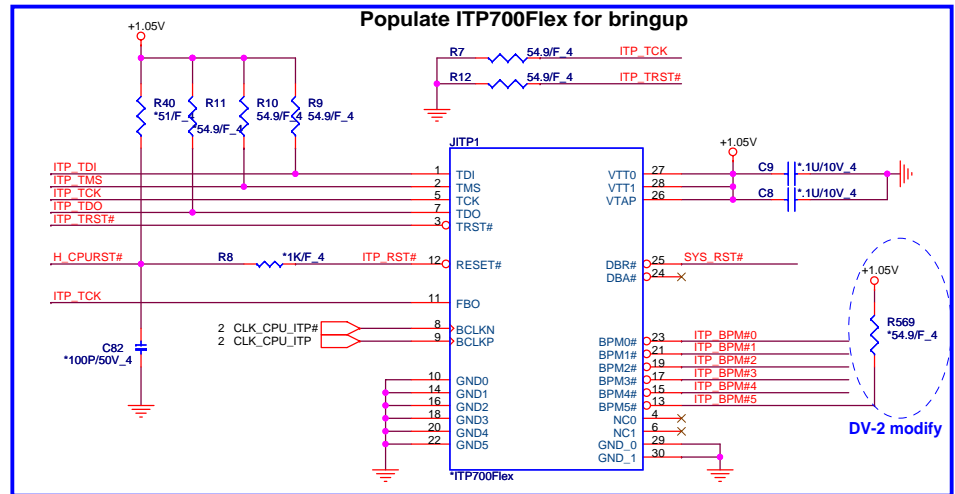

DV-2 modify



PROJECT : QL6
Quanta Computer Inc.

Size Custom	Document Number Penryn 1/2	Rev 2A
Date: Tuesday, February 26, 2008		Sheet 3 of 40

2,6,9,10,11,12,14,15,17,18,19,20,21,22,24,25,26,28,29,30,31,35,36,38 +3V
2,3,5,6,8,9,19,22,29,34,35 +1.05V
9,19,20,22,24,25,28,31,34,38 +1.5V
35 +VCCORE

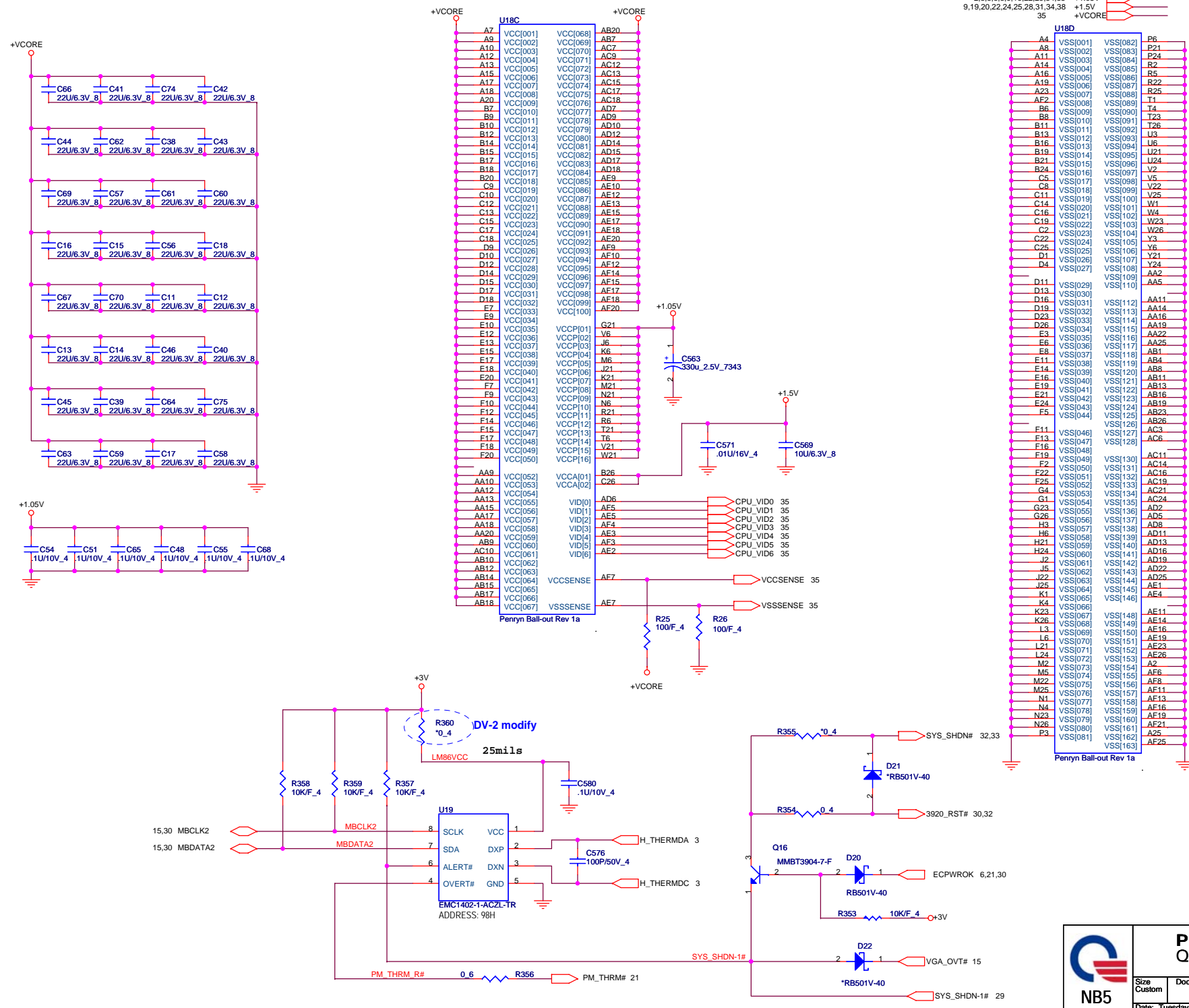

PROJECT : QL6
Quanta Computer Inc.

NB5

Size Custom Document Number Penryn & TH Monitor 2/2 Rev 2A
Date: Tuesday, February 26, 2008 Sheet 4 of 40

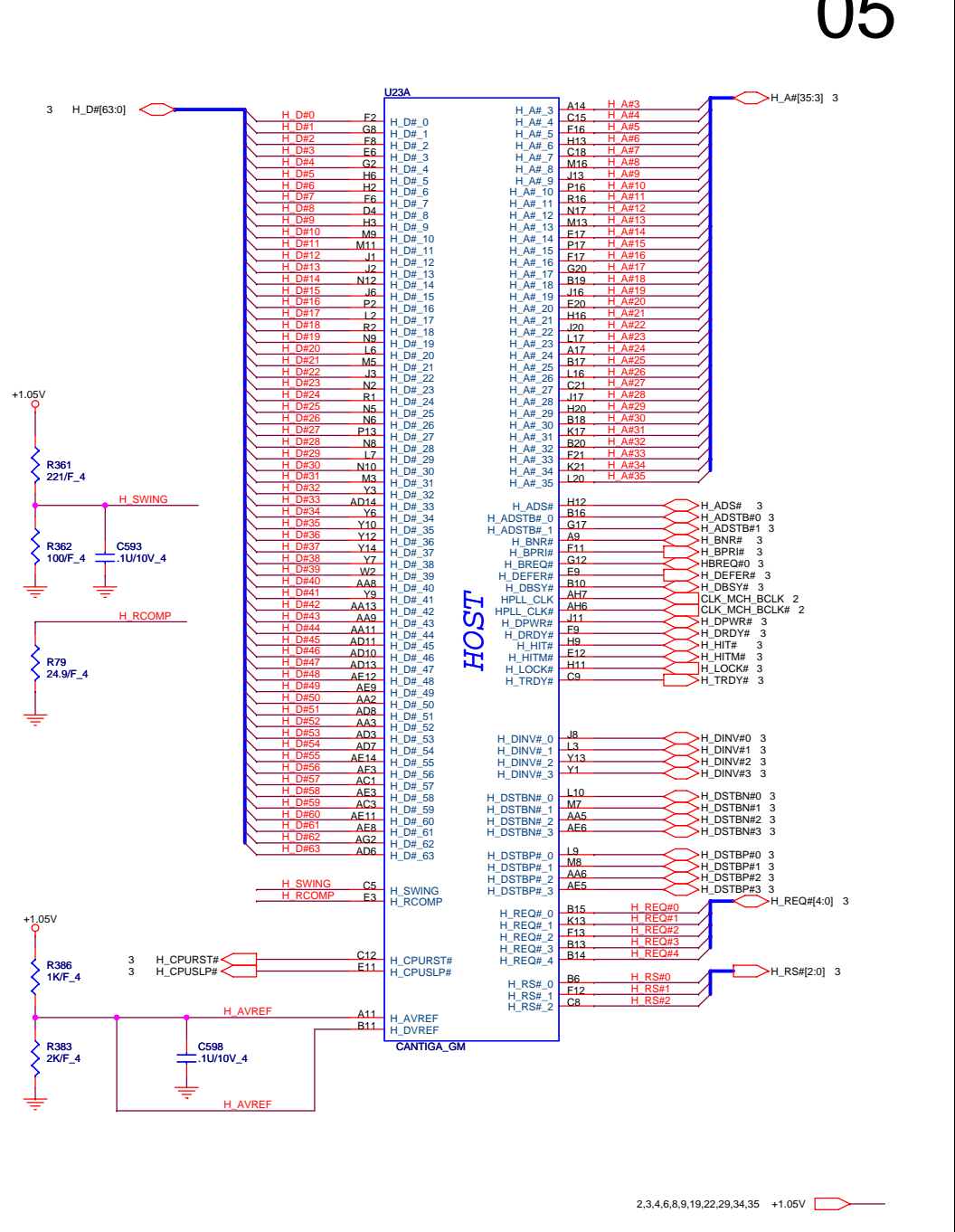
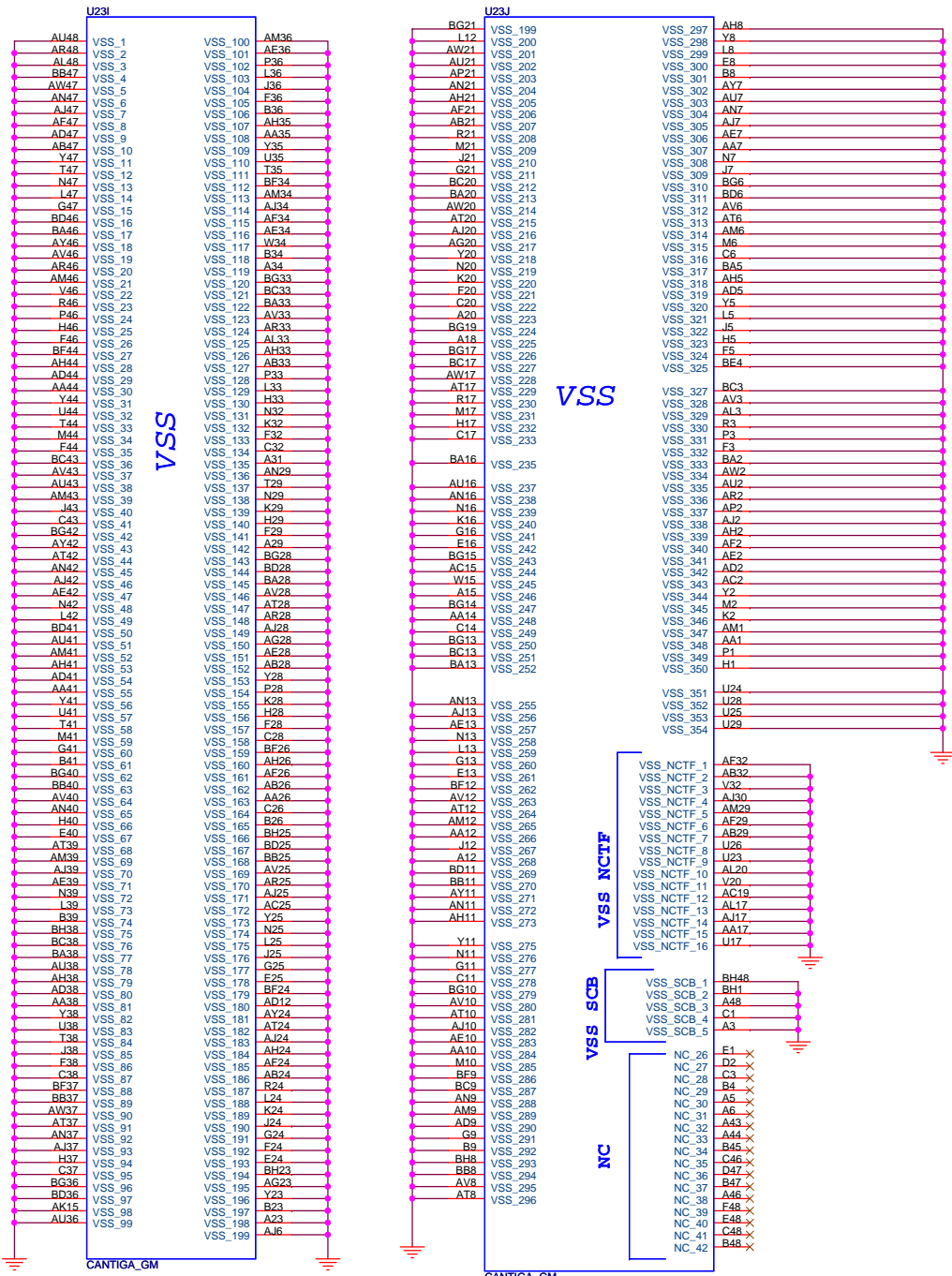

PROJECT : QL6
Quanta Computer Inc.

NB5

Size Custom Document Number **Cantiga Host & VSS 1/5** Rev 2A

Date: Tuesday, February 26, 2008 Sheet 5 of 40

2,4,9,10,11,12,14,15,17,18,19,20,21,22,24,25,26,28,30,31,35,36,38 +3V
 8.9,10,29,34,37 +1.8VSUS
 2,3,4,5,8,9,19,22,29,34,35 +1.05V_PEG
 9 +1.05V_PEG

MCH_CFG_5 DMi2 selection

Low: DMi2
 High: DMi4 (Default)
 MCH_CFG_9 PCI Express Graphic Lane

Low: Reverse Lane
 High: Normal operation(Default)
 MCH_CFG_19 DMI Lane Reversal

MCH_CFG_6 ITPM Host Interface

Low: ITPM Host Interface enabled
 High: ITPM Host Interface disabled (Default)
 MCH_CFG_7 Intel (R) Management Engine Crypto

Low: Intel (R) Management Engine Crypto
 TLS cipher suite with no confidentiality
 High: Intel (R) Management Engine Crypto
 TLS cipher suite with no confidentiality (Default)

MCH_CFG_10 PCIe Lookback Enable

Low: Enabled
 High: Disabled (Default)
 MCH_CFG_12/13 XOR/ALLZ/CLOCK Un-gating

MCH_CFG_13 MCH_CFG_12 Configuration

0	0	Reserved
1	0	XOR Mode enabled
0	1	All-Z Mode enabled
1	1	Normal operation (Default)

For iTPM

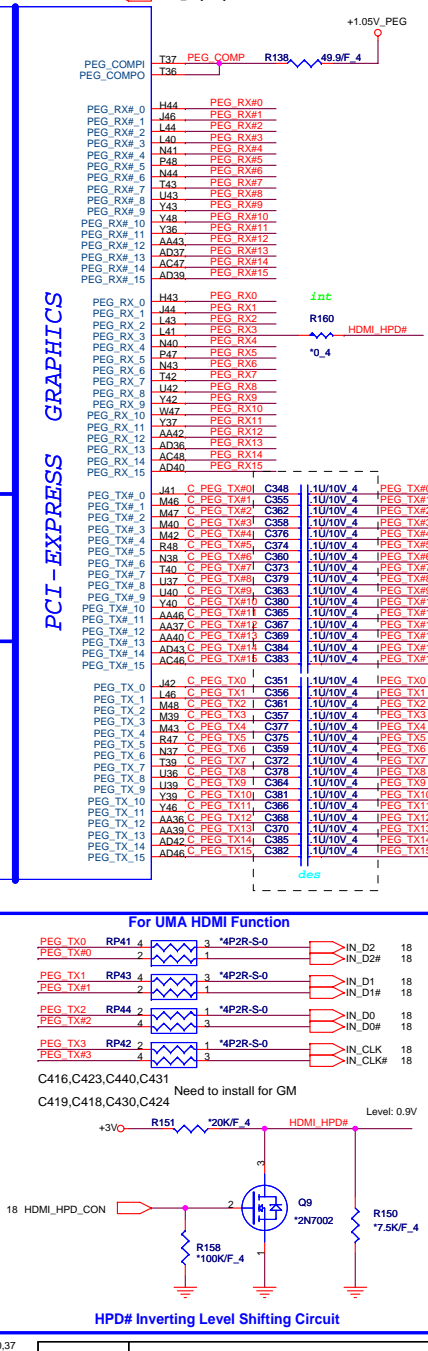
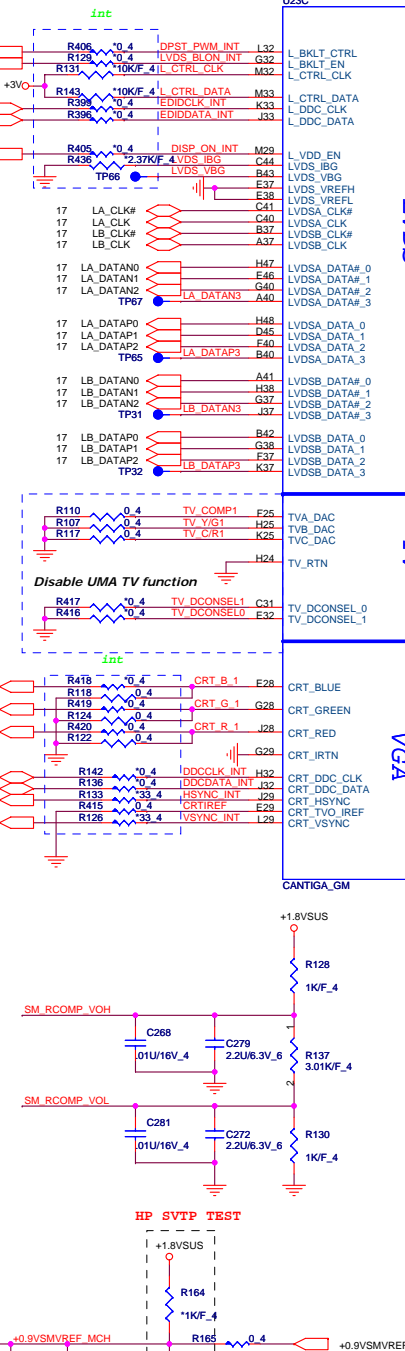
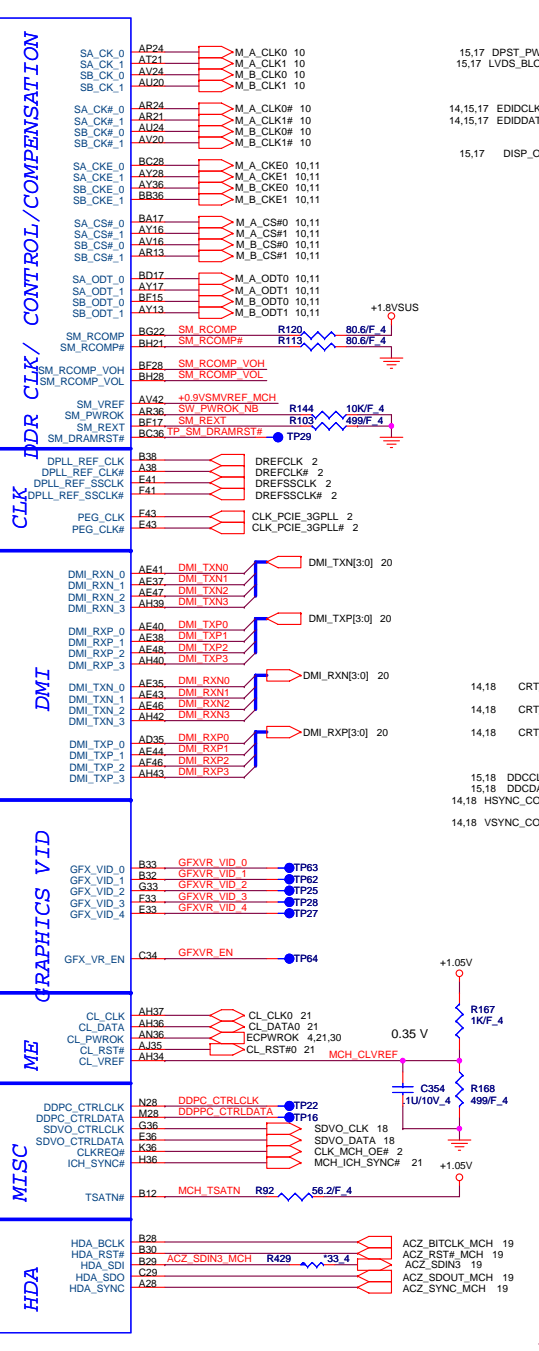
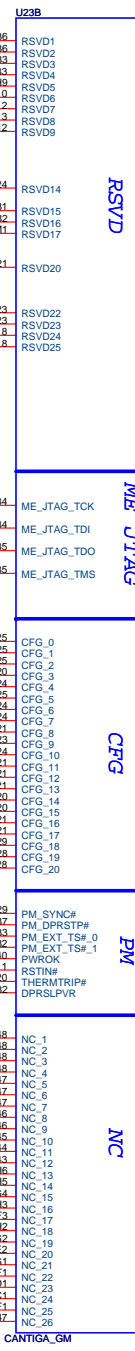
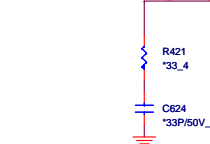
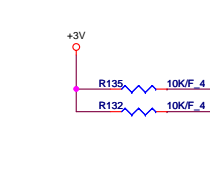
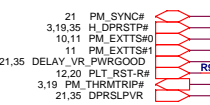
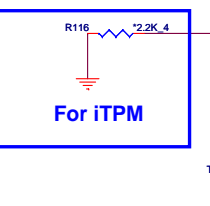

10 M_A_DQ[63:0]

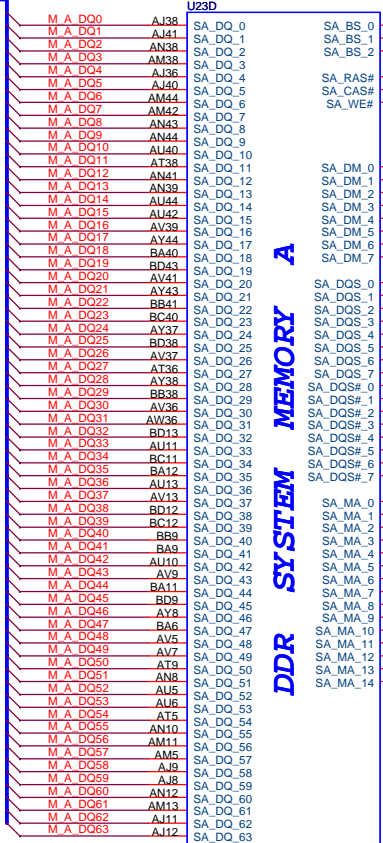

CANTIGA_GM

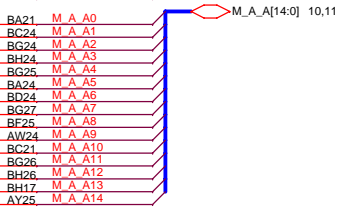
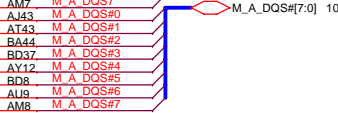
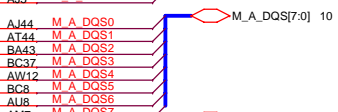
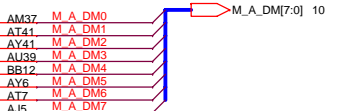
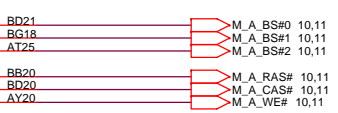

10 M_B_DQ[63:0]

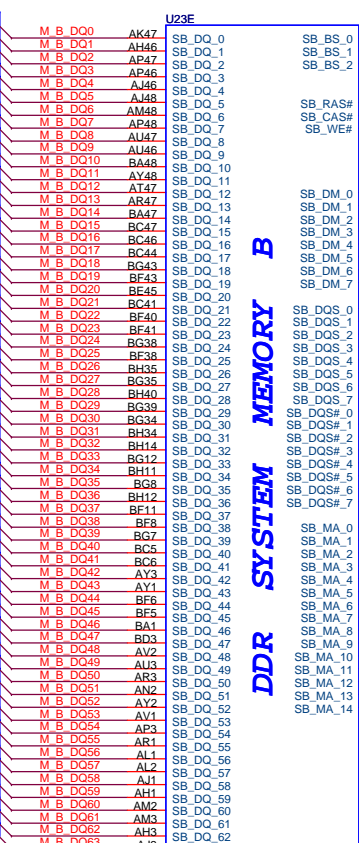

CANTIGA_GM

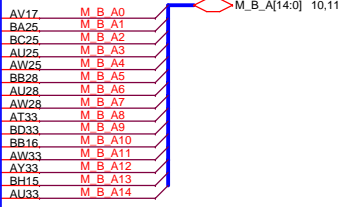
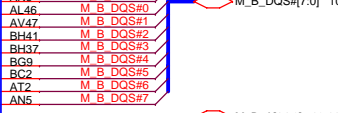
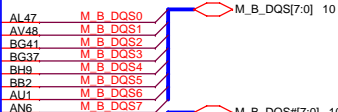
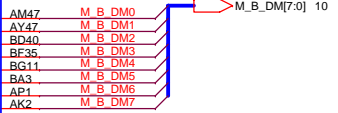
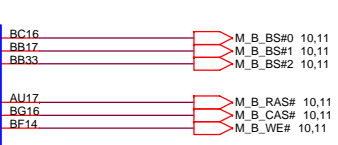

PROJECT : QL6
Quanta Computer Inc.

Size Custom	Document Number Cantiga DDR2 3/5	Rev 2A
Date: Tuesday, February 26, 2008		Sheet 7 of 40

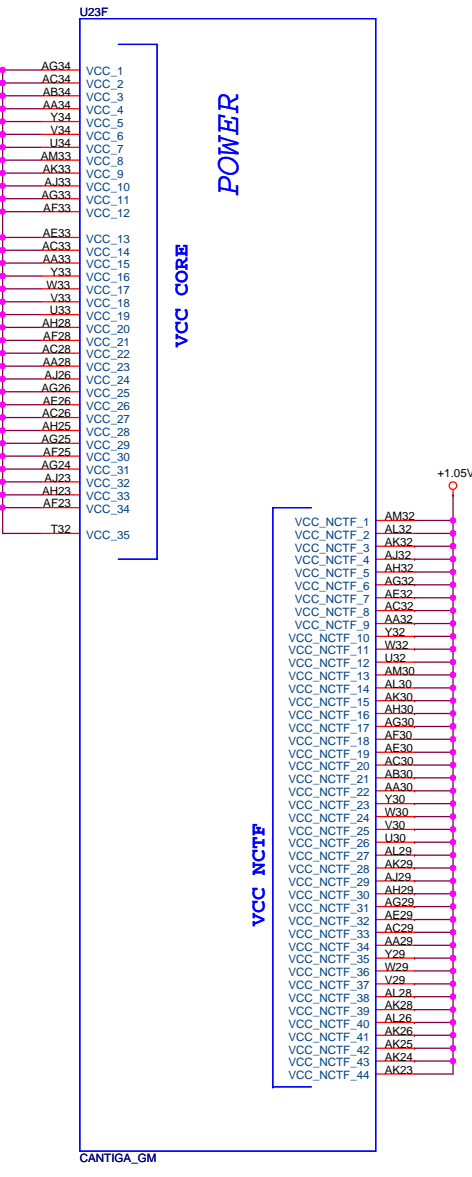
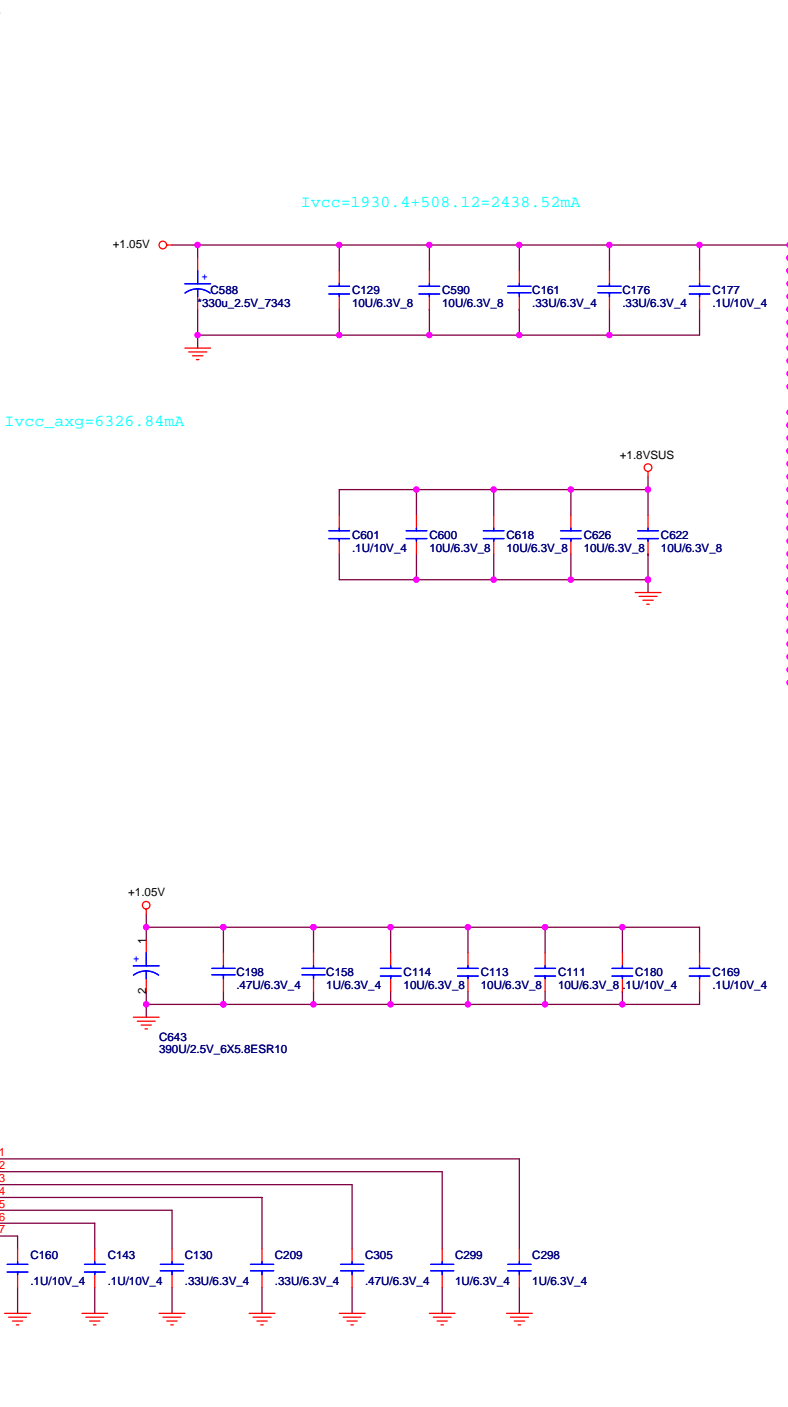
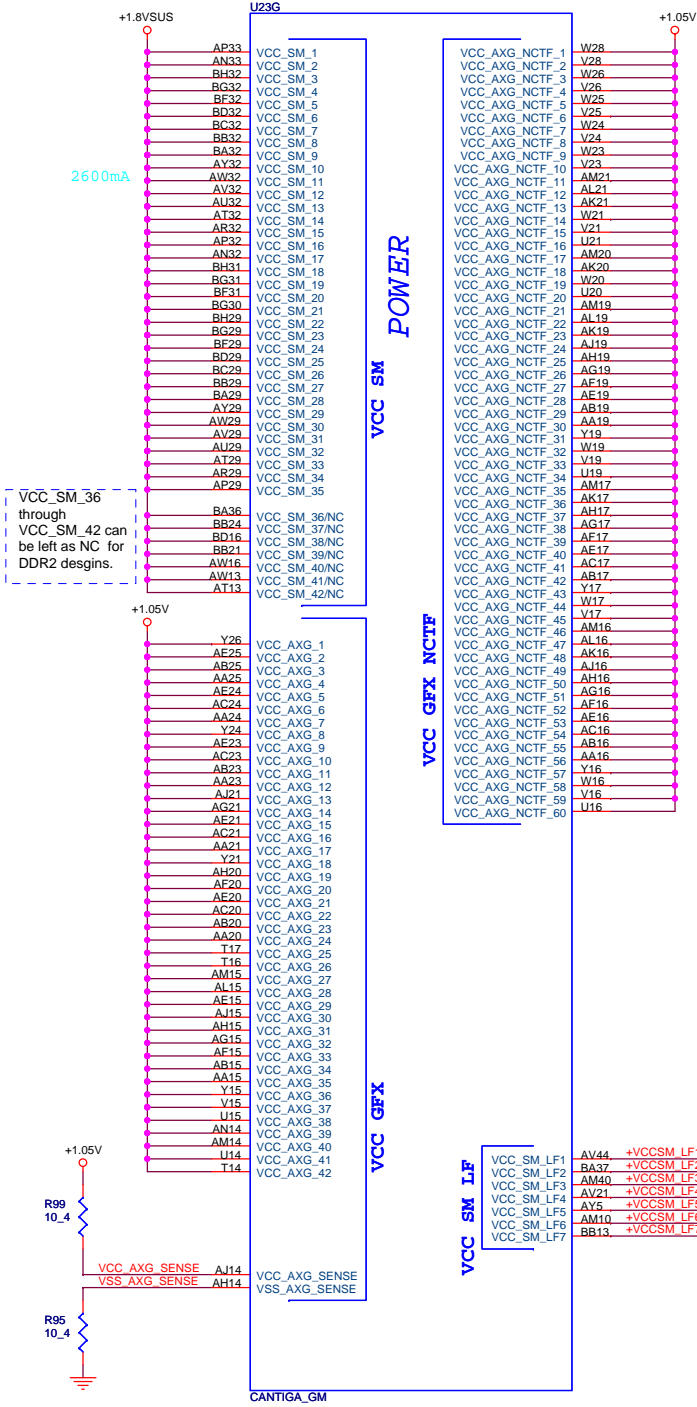

PROJECT : QL6
Quanta Computer Inc.

Size Custom	Document Number Cantiga Vcc 4/5	Rev 2A
Date: Tuesday, February 26, 2008 Sheet 8 of 40		

6,9,10,29,34,37 +1.8VSUS
2,3,4,5,6,9,19,22,29,34,35 +1.05V



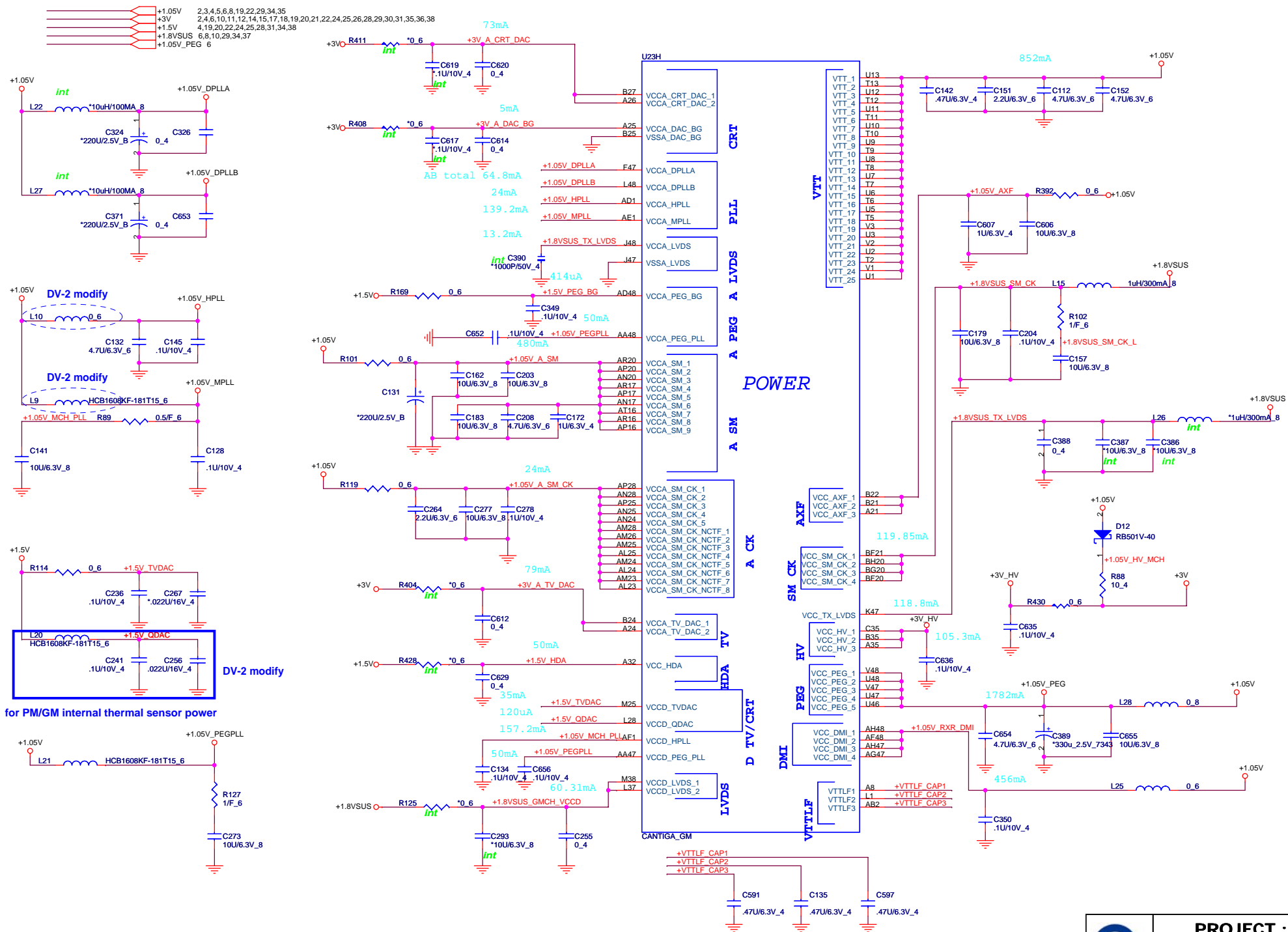

PROJECT : QL6
Quanta Computer Inc.

Size Custom	Document Number Cantiga Power 5/5	Rev 2A
Date: Tuesday, February 26, 2008		Sheet 9 of 40

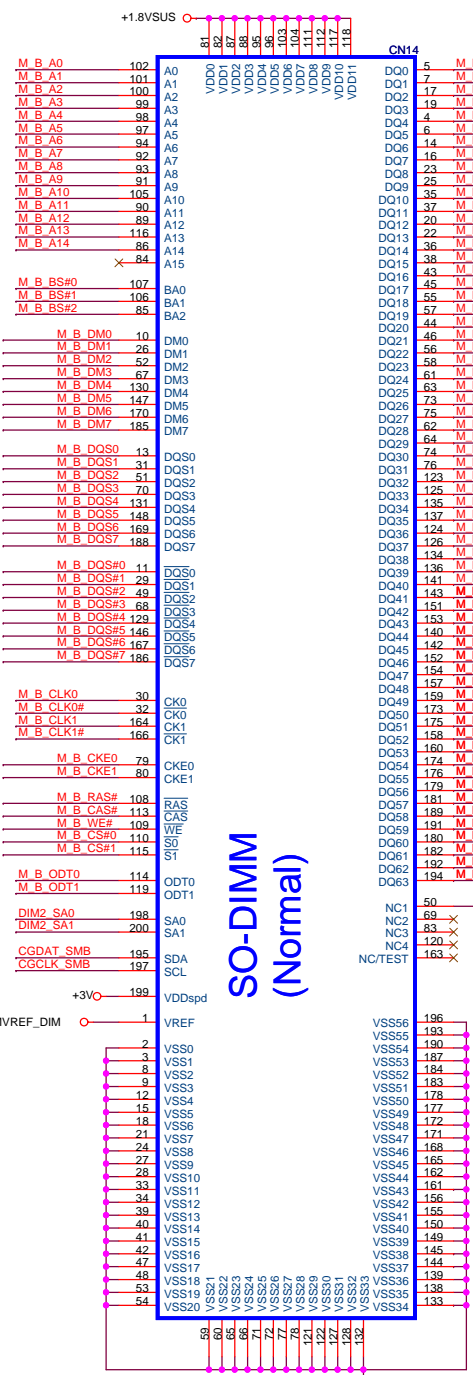

SO-DIMM (Normal)

H 9.2

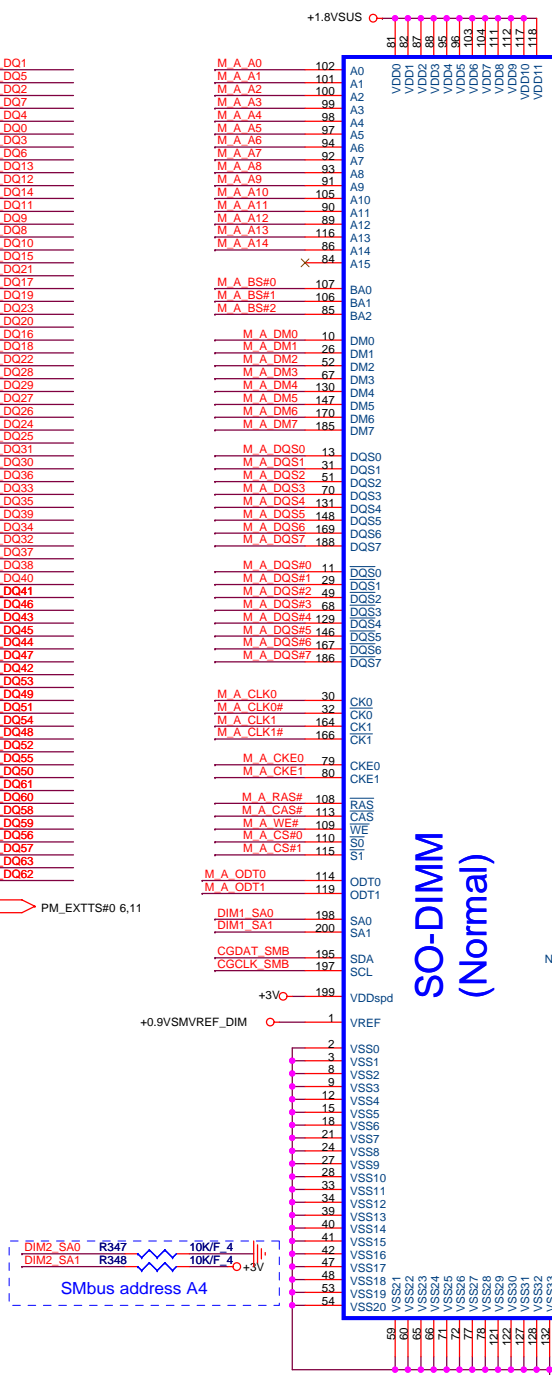

SO-DIMM (Normal)

H 5.2

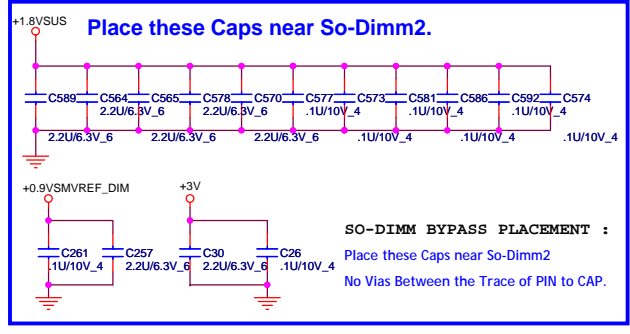
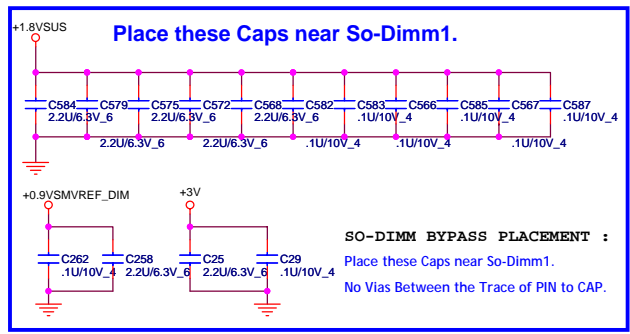
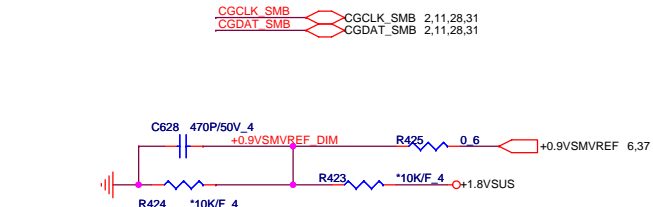
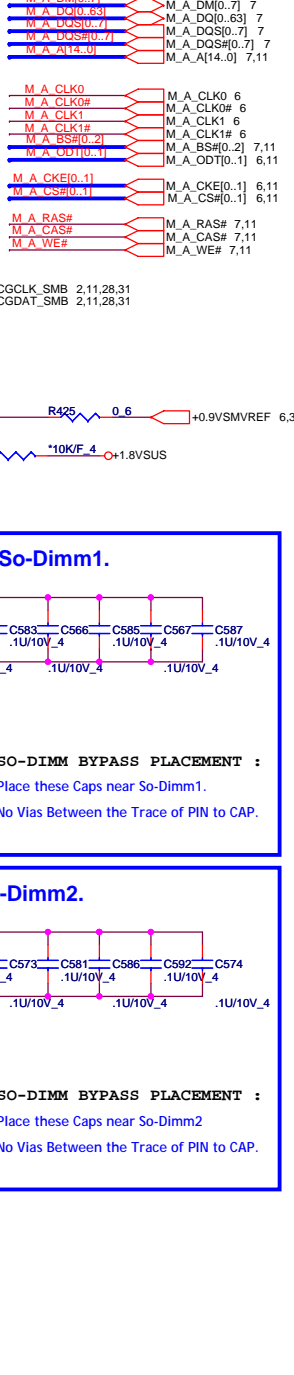
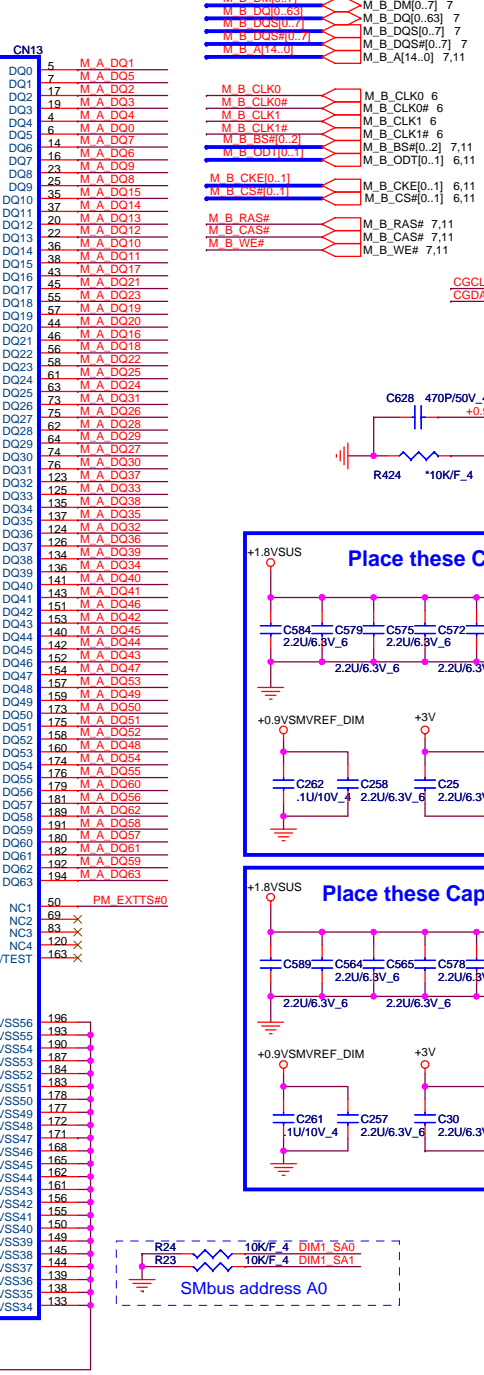

PROJECT : QL6
Quanta Computer Inc.

DDRII DUAL CHANNEL A,B.

DDRII A CHANNEL

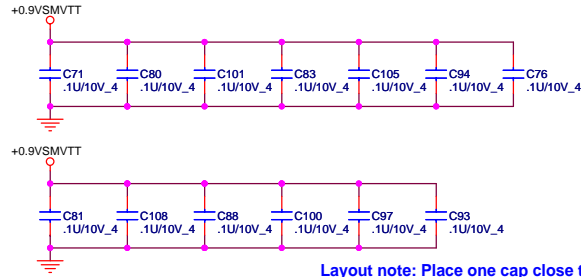

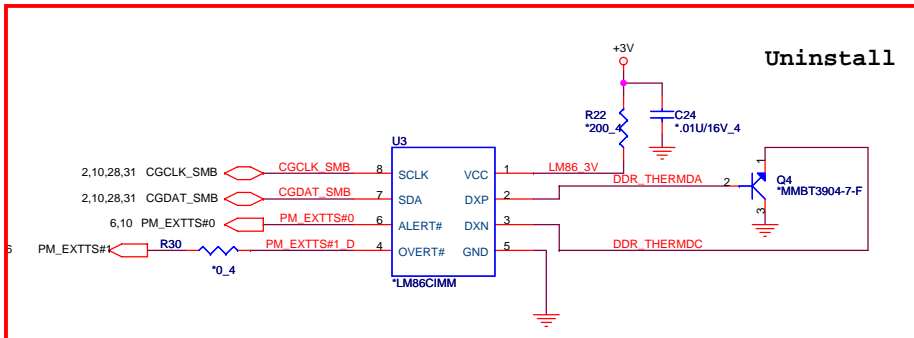
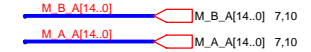
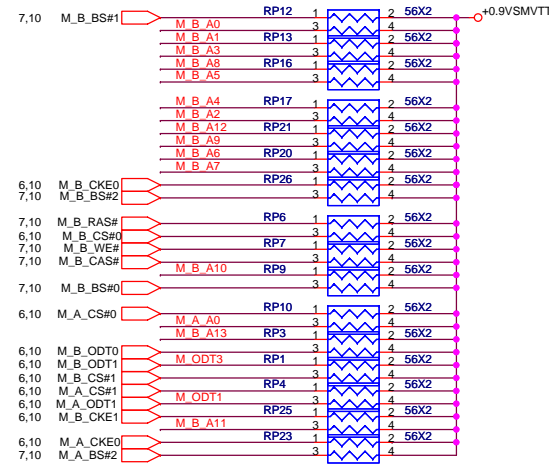
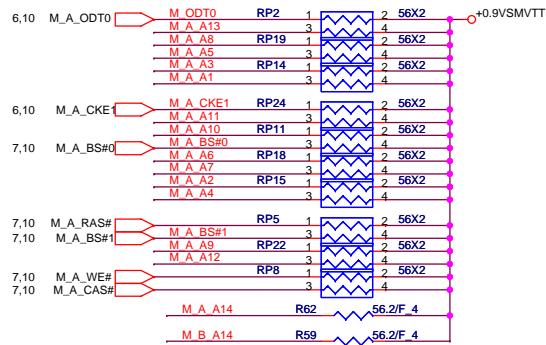
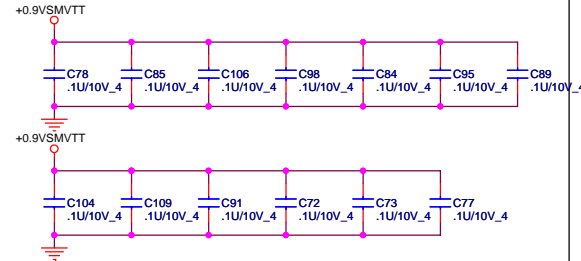

Layout note: Place one cap close to every 2 pullup resistors terminated to SMDR_VTERM

DDRII B CHANNEL

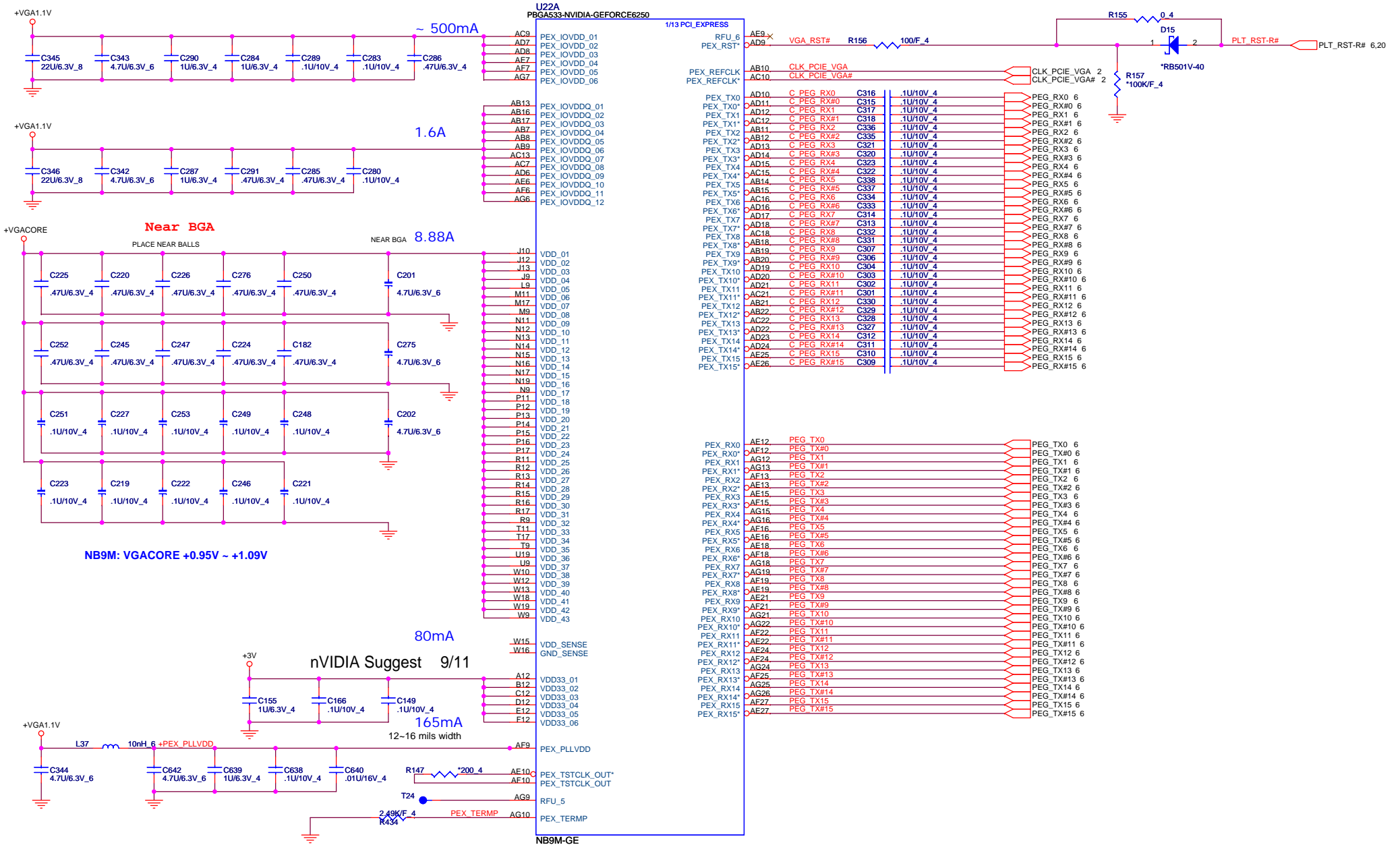

NB9M-GE (G98)





NB5

PROJECT : QL6
Quanta Computer Inc.

Size Custom	Document Number	Rev
NV9X (PCI E I/F) 1/5		2A
Date: Tuesday, February 26, 2008		Sheet 12 of 40

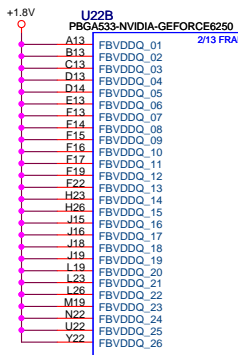

1.63A

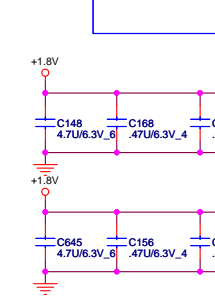
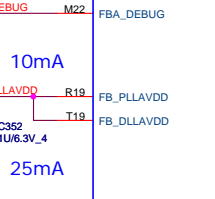
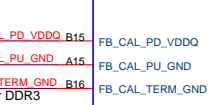
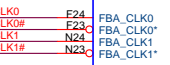
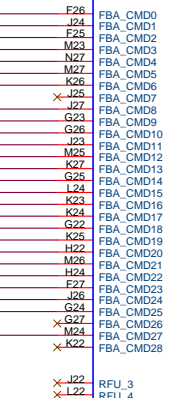

FBA_D0	D21	VMA_D00
FBA_D1	C22	VMA_D01
FBA_D2	A22	VMA_D02
FBA_D3	C24	VMA_D03
FBA_D4	B25	VMA_D04
FBA_D5	A25	VMA_D05
FBA_D6	A26	VMA_D06
FBA_D7	C27	VMA_D07
FBA_D8	E22	VMA_D08
FBA_D9	E24	VMA_D09
FBA_D10	D24	VMA_D10
FBA_D11	D26	VMA_D11
FBA_D12	D27	VMA_D12
FBA_D13	C27	VMA_D13
FBA_D14	B27	VMA_D14
FBA_D15	D16	VMA_D15
FBA_D16	E16	VMA_D16
FBA_D17	D17	VMA_D17
FBA_D18	F18	VMA_D18
FBA_D19	D20	VMA_D19
FBA_D20	F20	VMA_D20
FBA_D21	E21	VMA_D21
FBA_D22	F21	VMA_D22
FBA_D23	C18	VMA_D23
FBA_D24	B18	VMA_D24
FBA_D25	C18	VMA_D25
FBA_D26	C18	VMA_D26
FBA_D27	C19	VMA_D27
FBA_D28	C21	VMA_D28
FBA_D29	B21	VMA_D29
FBA_D30	A21	VMA_D30
FBA_D31	A21	VMA_D31
FBA_D32	P22	VMA_D32
FBA_D33	P24	VMA_D33
FBA_D34	R23	VMA_D34
FBA_D35	R23	VMA_D35
FBA_D36	F23	VMA_D36
FBA_D37	U24	VMA_D37
FBA_D38	V23	VMA_D38
FBA_D39	N24	VMA_D39
FBA_D40	N26	VMA_D40
FBA_D41	R25	VMA_D41
FBA_D42	R26	VMA_D42
FBA_D43	R26	VMA_D43
FBA_D44	T25	VMA_D44
FBA_D45	V26	VMA_D45
FBA_D46	V26	VMA_D46
FBA_D47	V27	VMA_D47
FBA_D48	W22	VMA_D48
FBA_D49	W22	VMA_D49
FBA_D50	W23	VMA_D50
FBA_D51	W24	VMA_D51
FBA_D52	AA22	VMA_D52
FBA_D53	AB23	VMA_D53
FBA_D54	AB24	VMA_D54
FBA_D55	AC24	VMA_D55
FBA_D56	W25	VMA_D56
FBA_D57	W26	VMA_D57
FBA_D58	W27	VMA_D58
FBA_D59	AA25	VMA_D59
FBA_D60	AB25	VMA_D60
FBA_D61	AB26	VMA_D61
FBA_D62	AD26	VMA_D62
FBA_D63	AD27	VMA_D63
FBA_DOM0	D23	VMA_DM0
FBA_DOM1	C26	VMA_DM1
FBA_DOM2	D19	VMA_DM2
FBA_DOM3	B19	VMA_DM3
FBA_DOM4	T24	VMA_DM4
FBA_DOM5	T26	VMA_DM5
FBA_DOM6	AA23	VMA_DM6
FBA_DOM7	AB27	VMA_DM7
FBA_DQS_WP0	A24	VMA_WDQS0
FBA_DQS_WP1	C25	VMA_WDQS1
FBA_DQS_WP2	E19	VMA_WDQS2
FBA_DQS_WP3	A19	VMA_WDQS3
FBA_DQS_WP4	T22	VMA_WDQS4
FBA_DQS_WP5	T27	VMA_WDQS5
FBA_DQS_WP6	AA24	VMA_WDQS6
FBA_DQS_WP7	AA26	VMA_WDQS7
FBA_DQS_RN0	B24	VMA_RDQS0
FBA_DQS_RN1	D25	VMA_RDQS1
FBA_DQS_RN2	E18	VMA_RDQS2
FBA_DQS_RN3	A18	VMA_RDQS3
FBA_DQS_RN4	R22	VMA_RDQS4
FBA_DQS_RN5	R27	VMA_RDQS5
FBA_DQS_RN6	Y24	VMA_RDQS6
FBA_DQS_RN7	AA27	VMA_RDQS7
FBA_CMD0	F26	FBA_CMD0
FBA_CMD1	J24	FBA_CMD1
FBA_CMD2	F25	FBA_CMD2
FBA_CMD3	M23	FBA_CMD3
FBA_CMD4	N27	FBA_CMD4
FBA_CMD5	M27	FBA_CMD5
FBA_CMD6	K26	FBA_CMD6
FBA_CMD7	J25	FBA_CMD7
FBA_CMD8	G23	FBA_CMD8
FBA_CMD9	G26	FBA_CMD9
FBA_CMD10	G26	FBA_CMD10
FBA_CMD11	K23	FBA_CMD11
FBA_CMD12	J27	FBA_CMD12
FBA_CMD13	M25	FBA_CMD13
FBA_CMD14	G25	FBA_CMD14
FBA_CMD15	L24	FBA_CMD15
FBA_CMD16	K23	FBA_CMD16
FBA_CMD17	K24	FBA_CMD17
FBA_CMD18	G22	FBA_CMD18
FBA_CMD19	K25	FBA_CMD19
FBA_CMD20	H22	FBA_CMD20
FBA_CMD21	M26	FBA_CMD21
FBA_CMD22	H24	FBA_CMD22
FBA_CMD23	F27	FBA_CMD23
FBA_CMD24	J26	FBA_CMD24
FBA_CMD25	G24	FBA_CMD25
FBA_CMD26	X G27	FBA_CMD26
FBA_CMD27	M24	FBA_CMD27
FBA_CMD28	X K22	FBA_CMD28
RFU_3	X J22	RFU_3
RFU_4	X L22	RFU_4

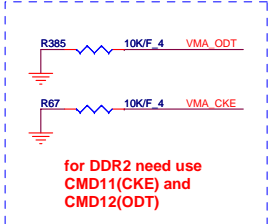
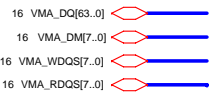

for DDR2 need use CMD11(CKE) and CMD12(ODT)

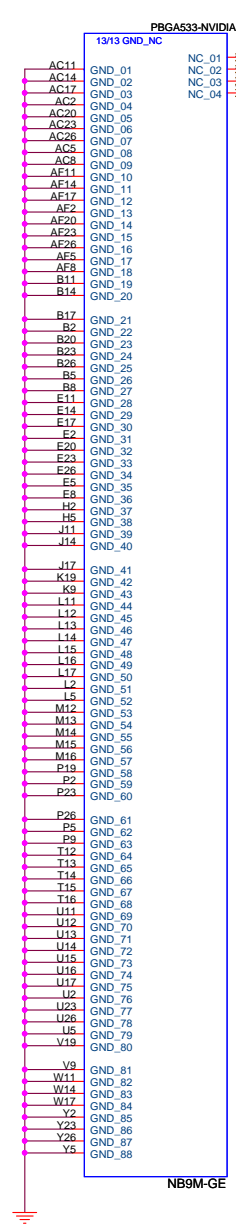
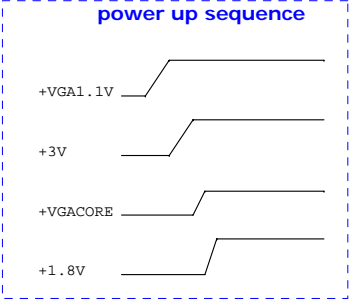

13

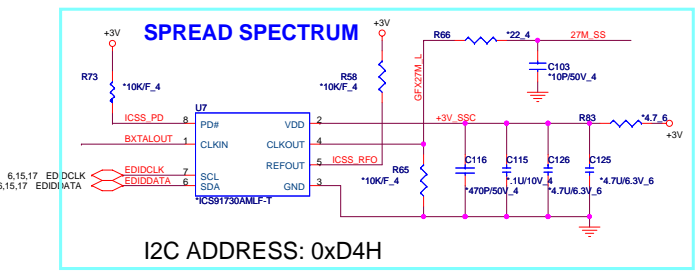
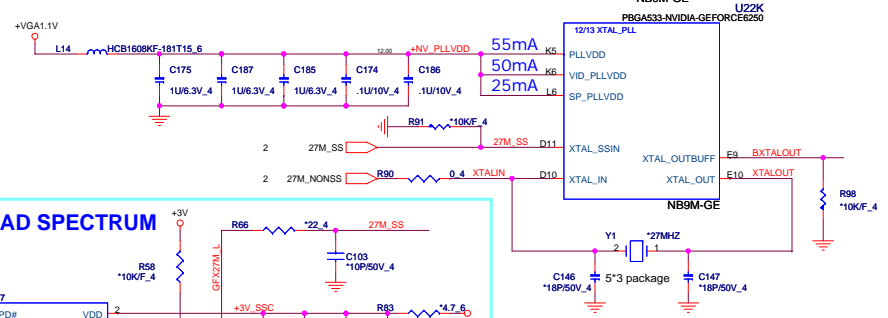
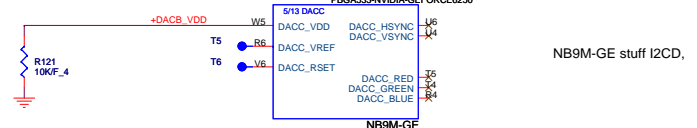
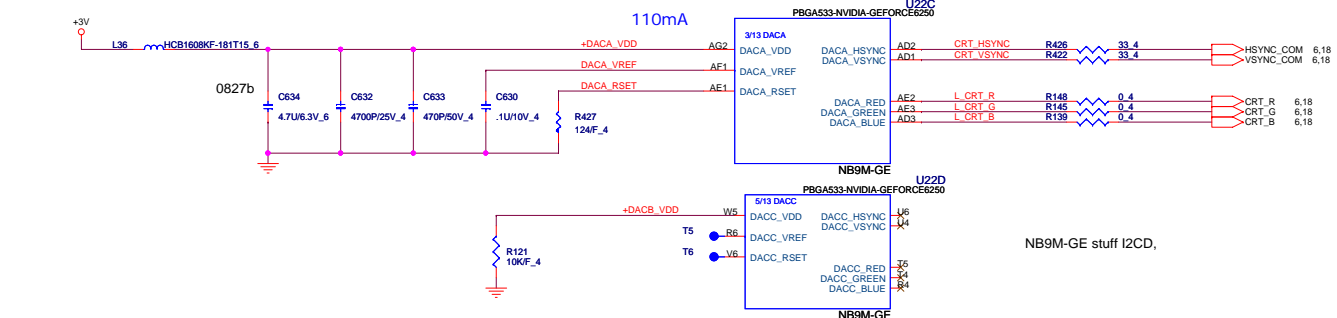
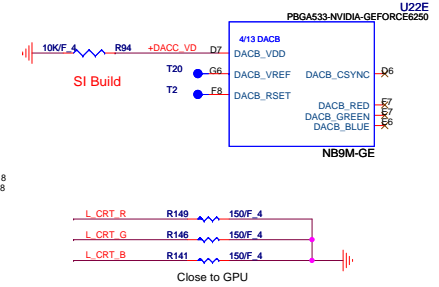
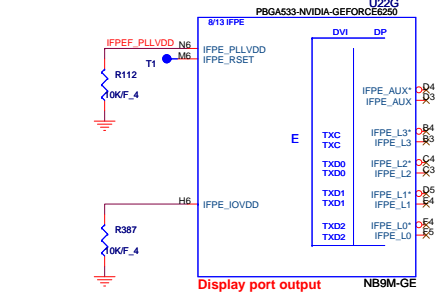
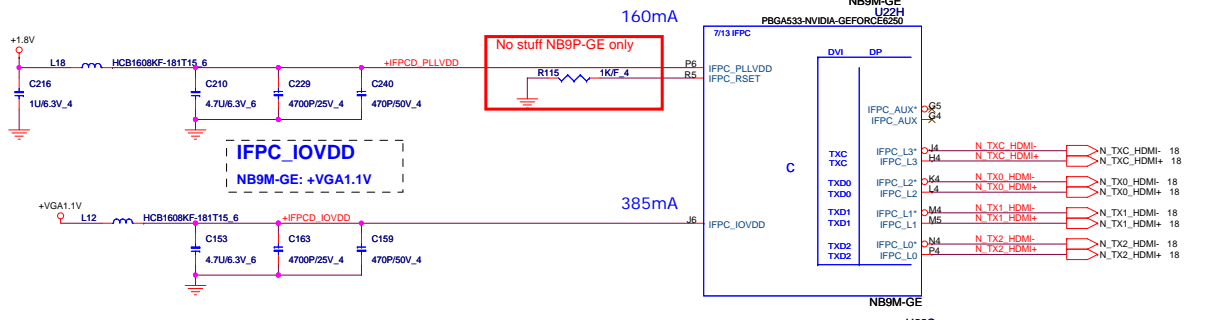
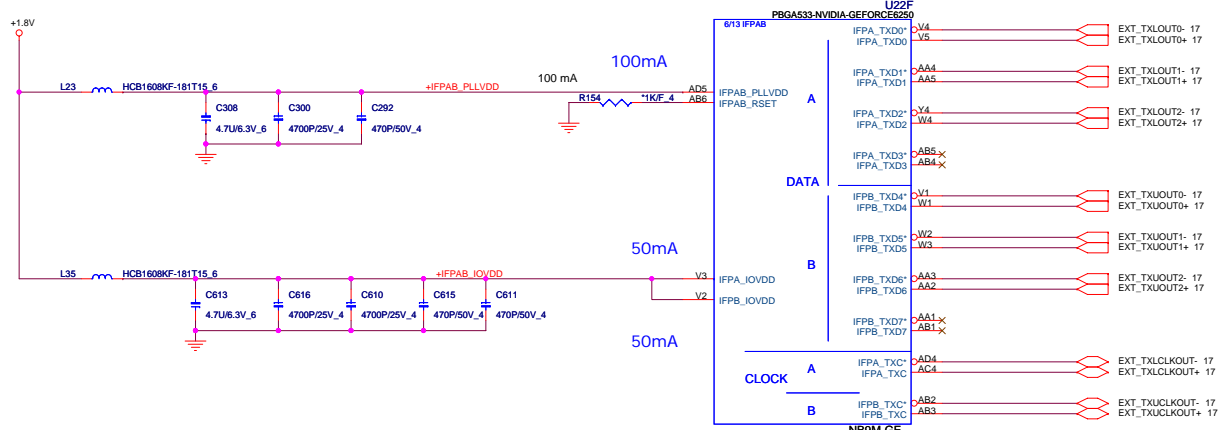

Install it when not connected to Spread spectrum device

PROJECT : QL6
Quanta Computer Inc.

Size: Custom
Document Number: **NV9X (DISPLAY) 3/5**
Rev: 2A

Date: Tuesday, February 26, 2008 | Sheet: 14 of 40

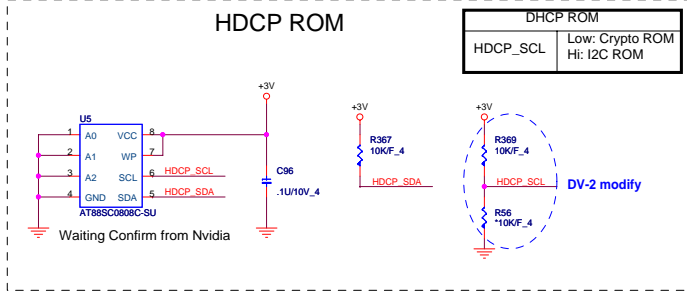
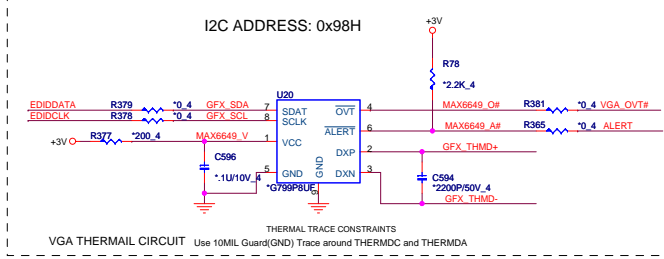
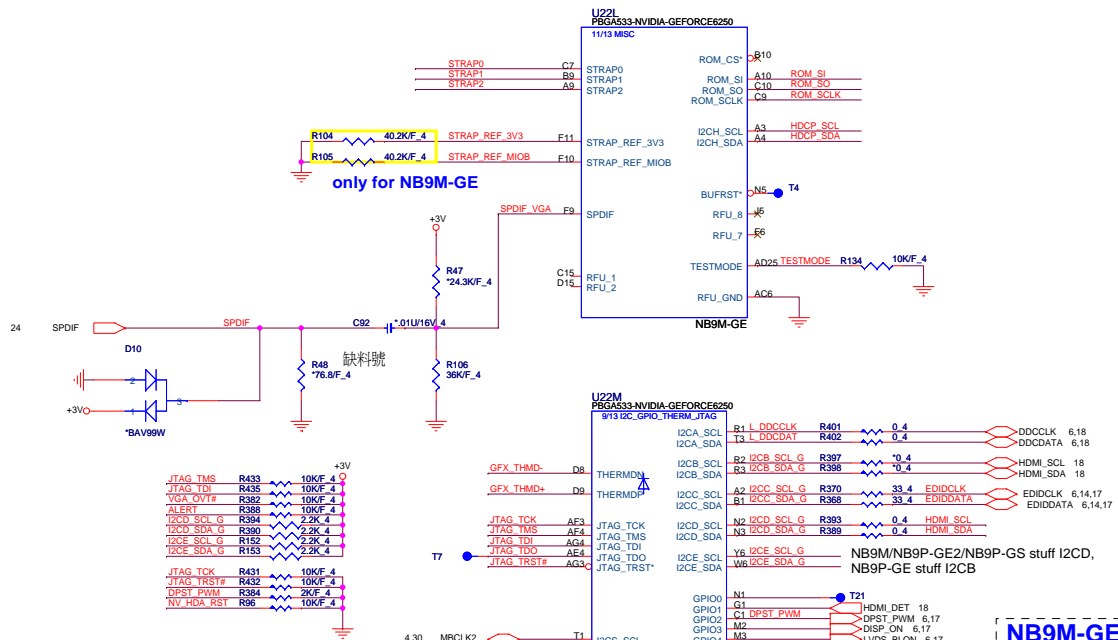

NB9M-GE (G98) Strapps GPIO ASSIGNMENTS

GPIO	I/O	ACTIVE	USAGE
0	IN	N/A	PRIMARY DVI HOTPLUG
1	IN	N/A	SECONDARY DVI HOTPLUG
2	OUT	HIGH	PANEL BACKLIGHT PWM
3	OUT	HIGH	PANEL POWER ENABLE
4	OUT	HIGH	PANEL BACKLIGHT ENABLE
5	OUT	N/A	NVDD VID0
6	OUT	N/A	NVDD VID1
7	OUT	N/A	FBVDD VID0
8	IN	LOW	THERMAL ALERT
9	OUT	LOW	FAN PWM
10	OUT	N/A	SLI FBVREF SELECT
11	OUT	N/A	SLI SYNC0
12	IN	N/A	AC DETECT
13	OUT	N/A	PS CONTROL OR HDMI_CEC
14	OUT	HIGH	PS CONTROL

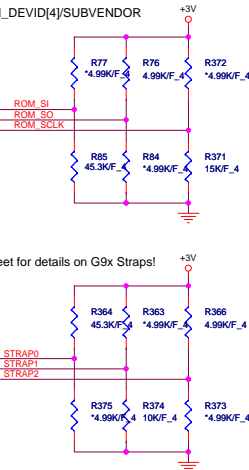

VRAM ID		
ROM_SI	PD 30K: Samsung	
	PD 35K: Qimonda	
	PD 45K: Hynix	

Logical Strap Bit Mapping		
PU-VDD	PD	
5K	1000	0000
10K	1001	0001
15K	1010	0010
20K	1011	0011
25K	1100	0100
30K	1101	0101
35K	1110	0110
45K	1111	0111

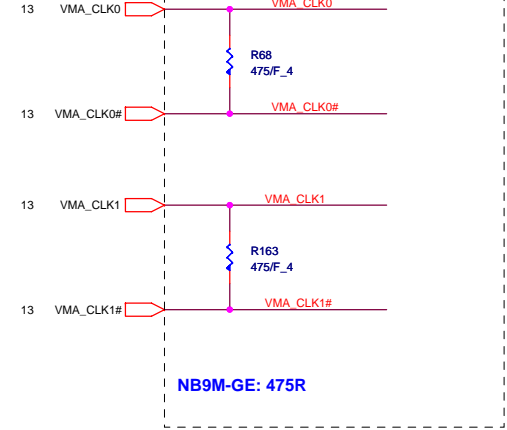
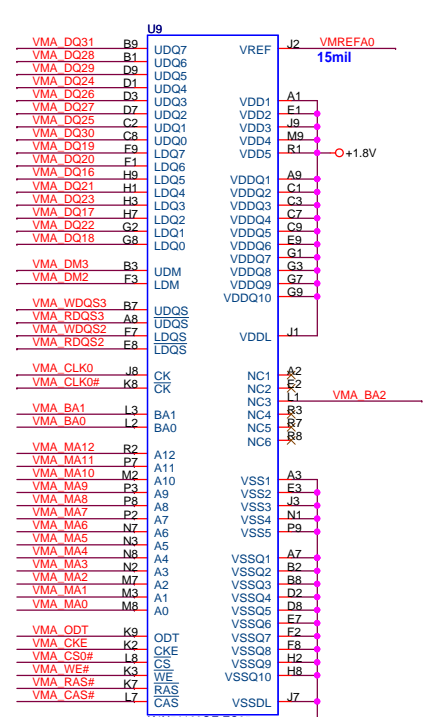
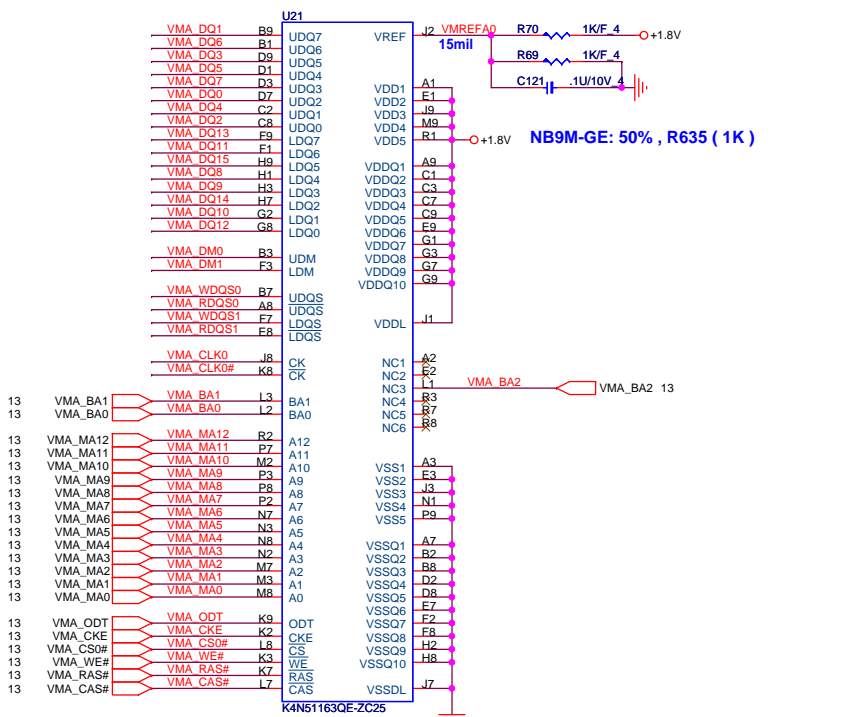

CS14752FB11 RES CHIP 475 1/16W +1%(0402)

(By pass capacitor)

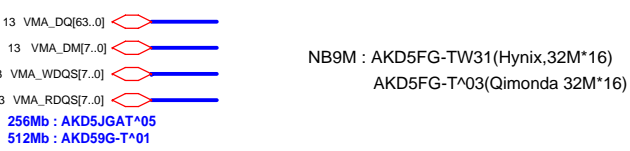
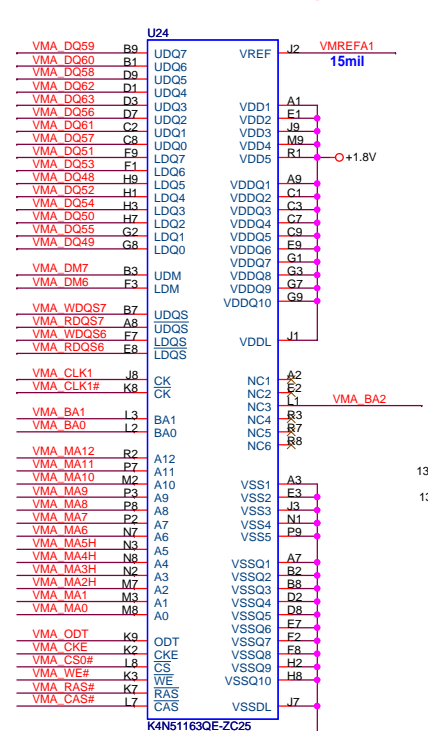
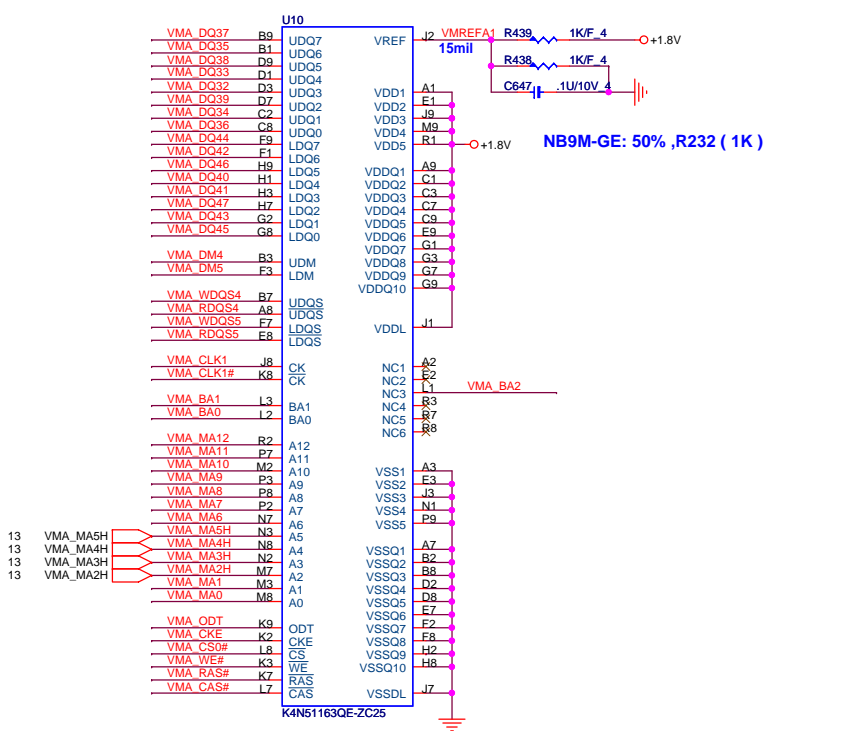
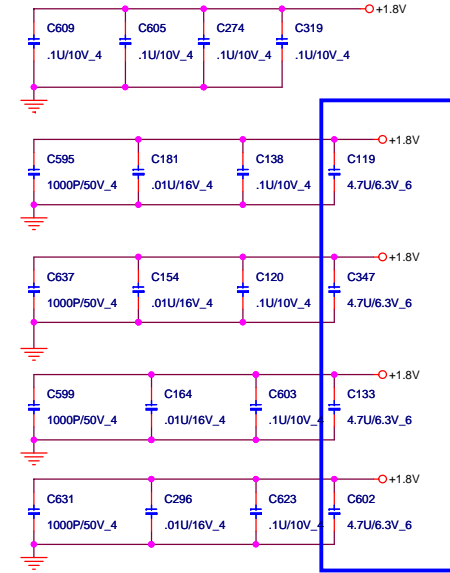

NB9M : AKD5FG-TW31(Hynix,32M*16) AKD5FG-T*03(Qimonda 32M*16)

PROJECT : QL6
Quanta Computer Inc.

Size Custom Document Number **NV9X VRAM-1(GDDR2) 5/5** Rev 2A

Date: Tuesday, February 26, 2008 Sheet 16 of 40

1. If LCD connector near GPU, then place these series Resistors near GPU
2. If LCD connector near N/B, then place these series Resistors near N/B

OPTION SIGNAL FROM NB FOR UMA VGA

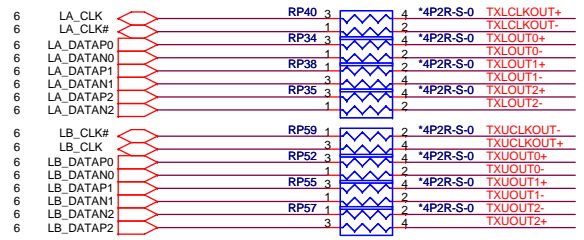

OPTION SIGNAL FROM Nvidia to VGA

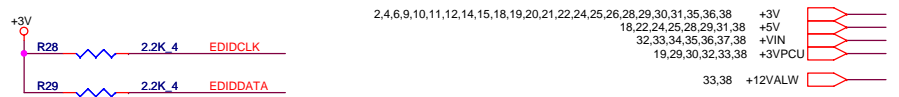
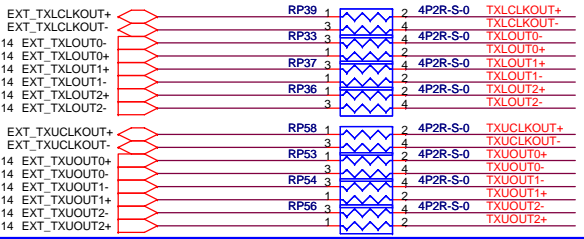

LCD / USB CAMERA / DIGITAL MIC CONNECTOR

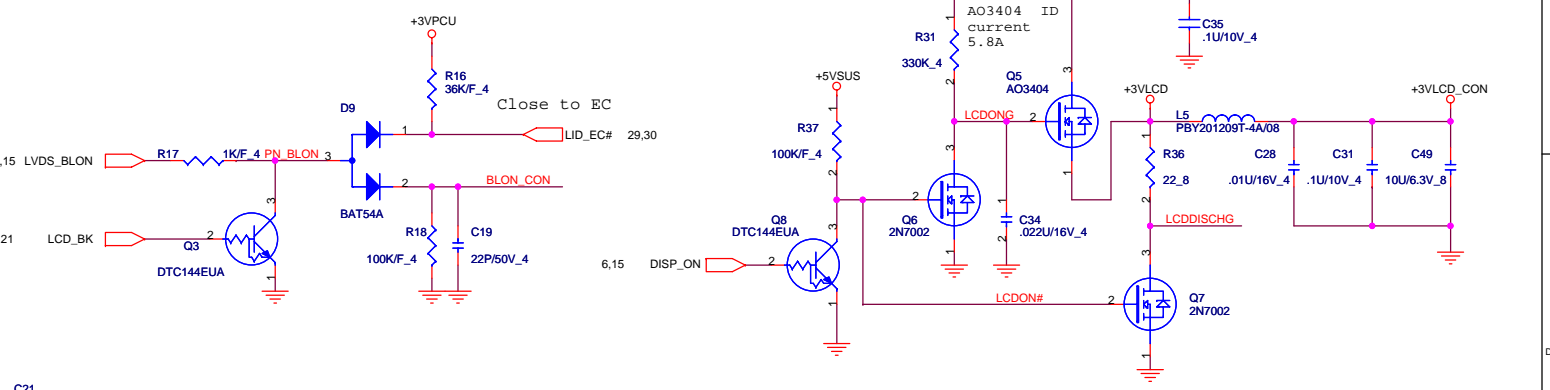
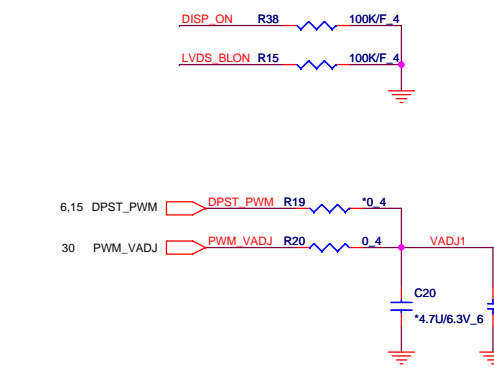
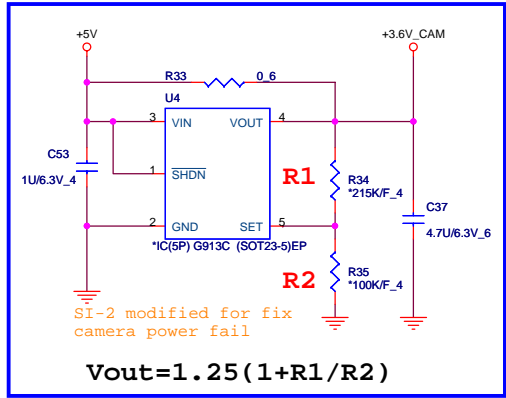
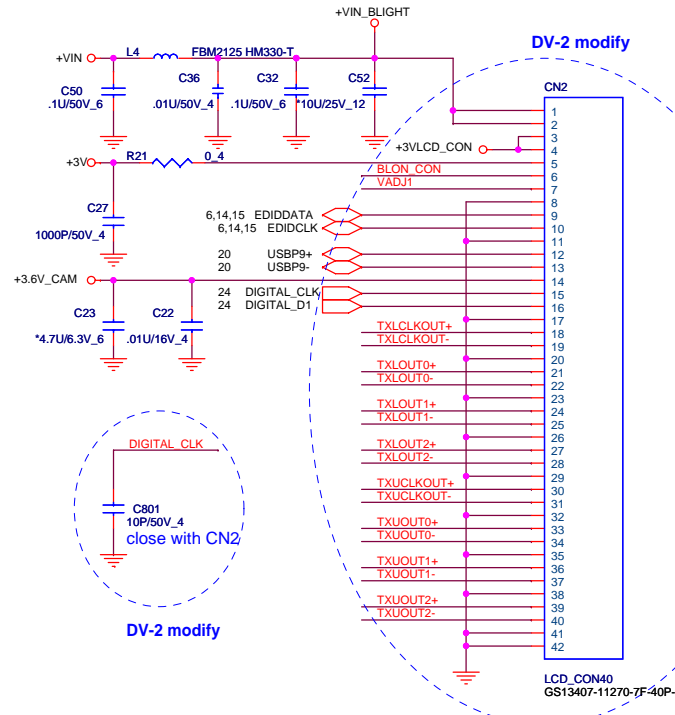

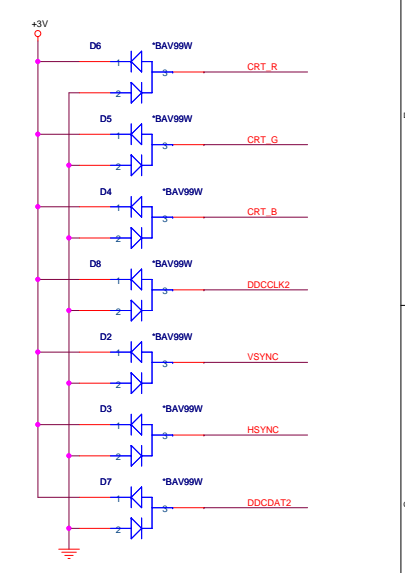
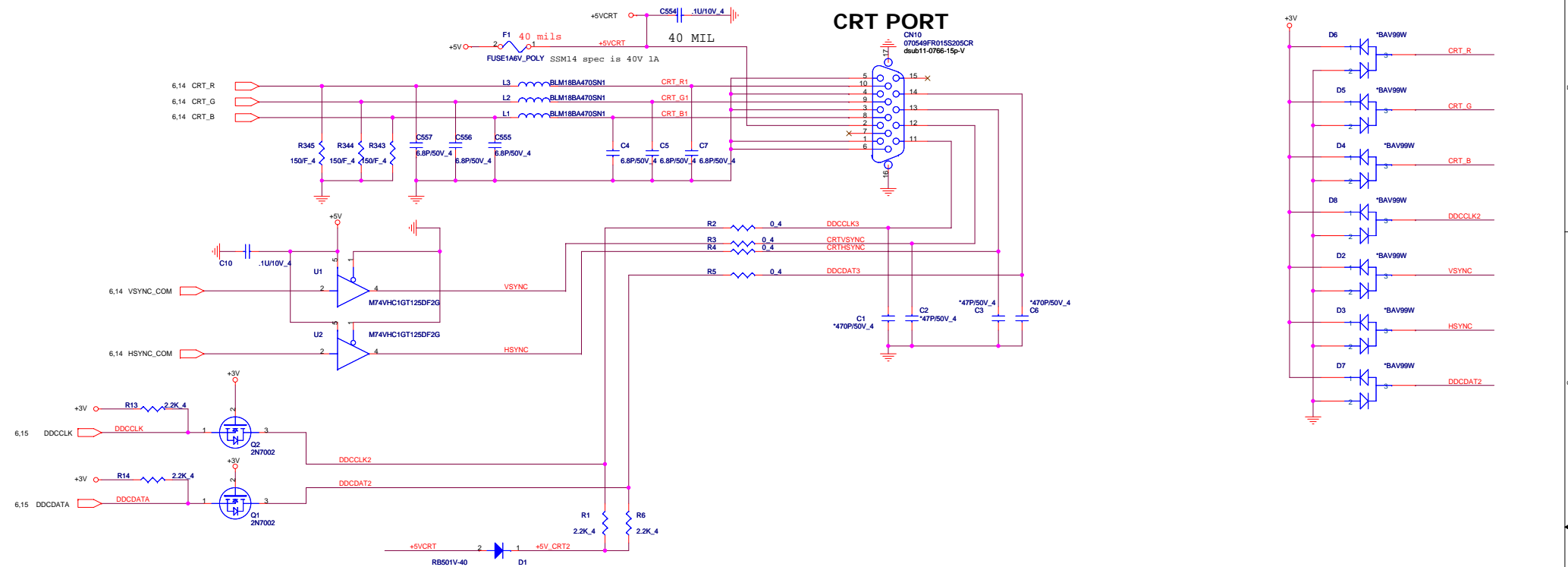

For UMA HDMI function

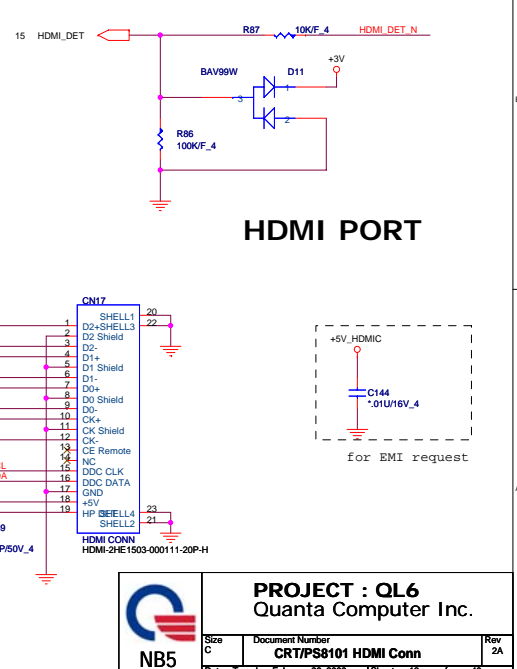
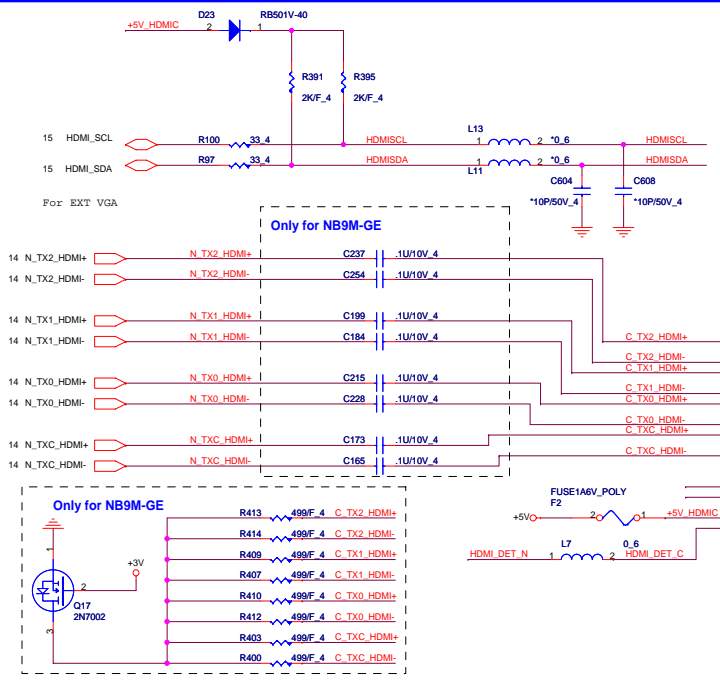
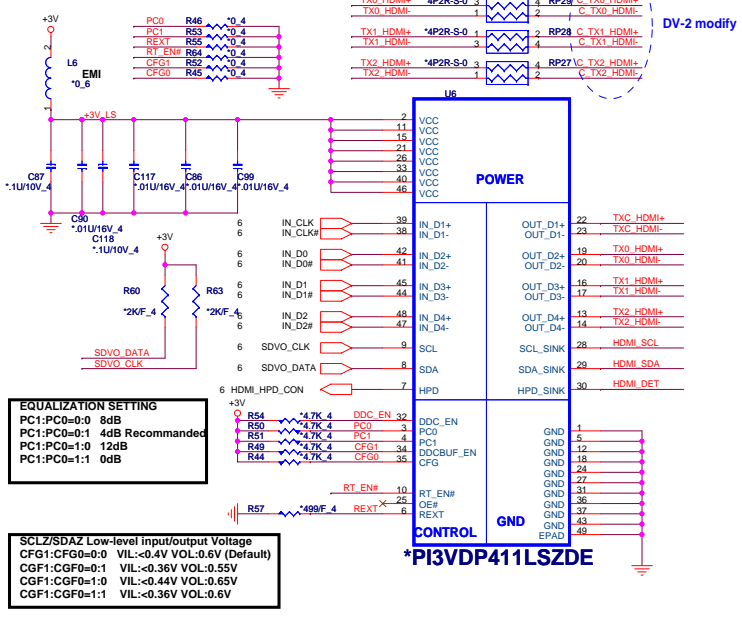

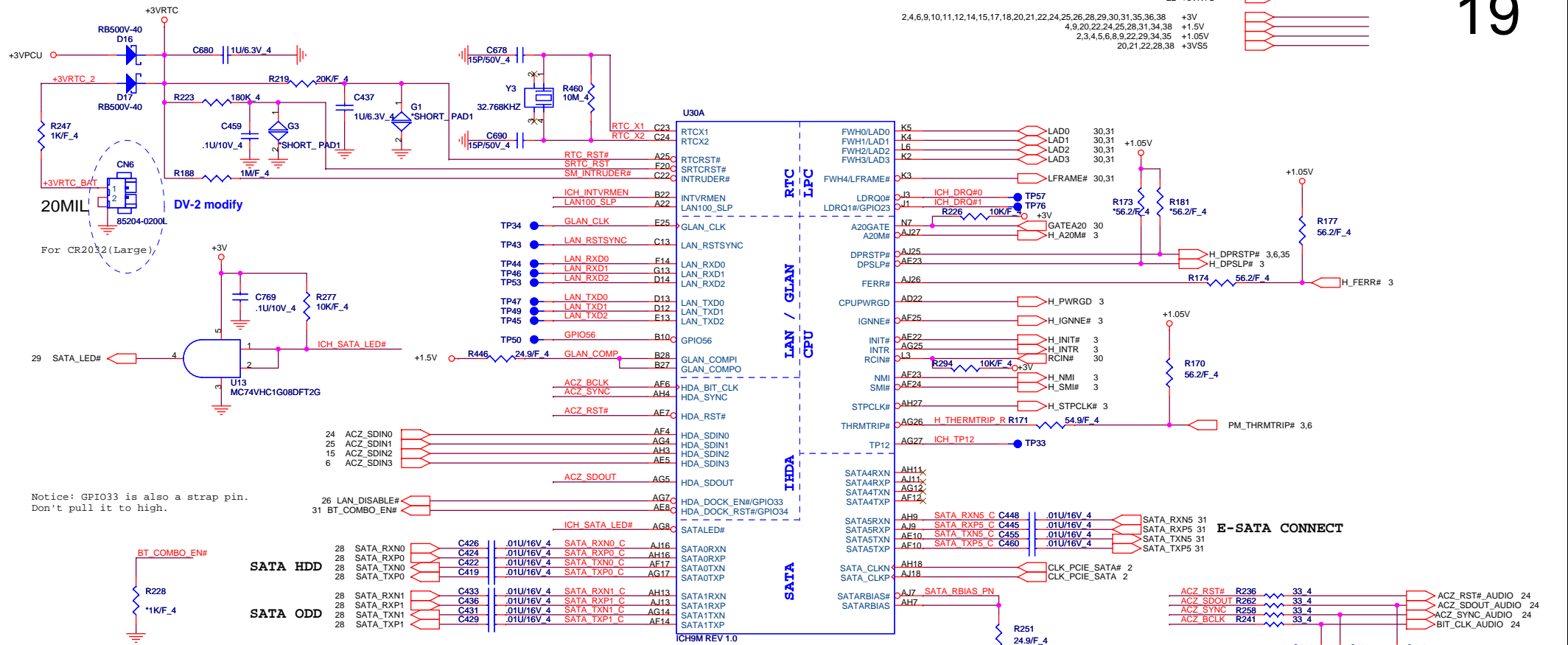

Notice: GPIO33 is also a strap pin. Don't pull it to high.

SB Strap

ICH9-M Internal VR Enable strap
 Enable strap (Internal VR for VccSus1_05, VccSus1_5 and VccCL1_5)

ICH9-M LAN100_SLP Strap
 (Internal VR for VccLAN1_05 and VccCL1_05)

INTVRMEN: Low = Internal VR disable, High = Internal VR enable (Default)

LAN100_SLP: Low = Internal VR disable, High = Internal VR enable (Default)

XOR Chain Entrance Strap

ICH_TP3	HDA_SDOUT	Description
0	0	RSVD
0	1	Enter XOR Chain
1	0	Normal operation (Default)
1	1	Set PCIe port config bit 1

A16 swap override strap
 Low = A16 swap override enabled
 Hi = Default

TPM physical presence
 ICH_GPIO57 Low: Default

ICH9 Boot BIOS select

STRAP	PCI_GNT0#	SPL_CS#1
SPI	0	1
PCI	1	0
LPC	1	1

(default)

No Reboot Strap

ACZ_SPKR	Low: Default Hi: No reboot
----------	-------------------------------

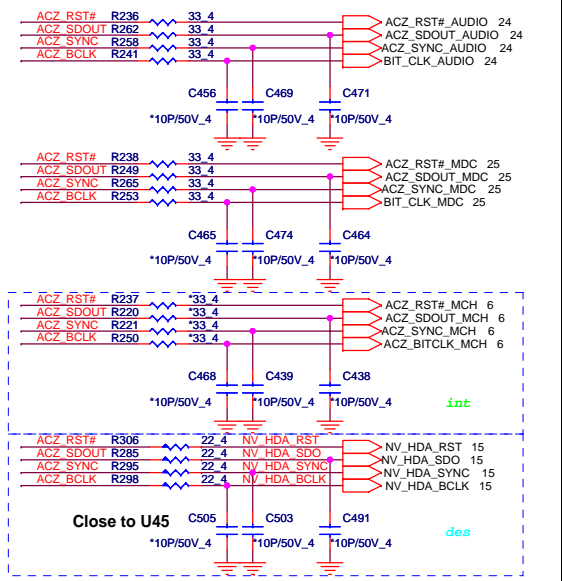

PROJECT : QL6
 Quanta Computer Inc.

NB5

Size Custom Document Number **ICH9-M Host 1/4** Rev 2A

Date: Tuesday, February 26, 2008 Sheet 19 of 40

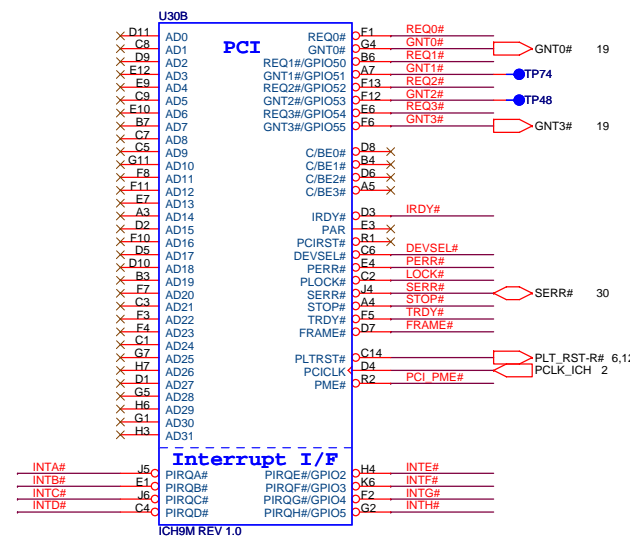
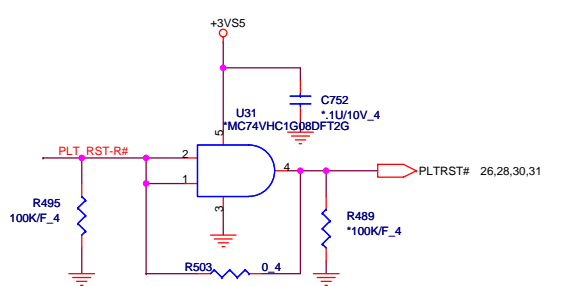
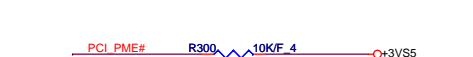
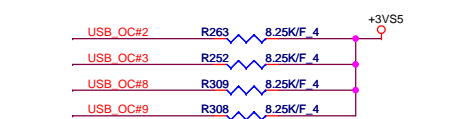
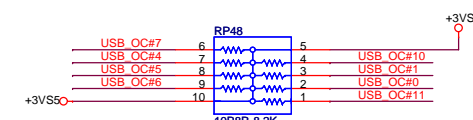
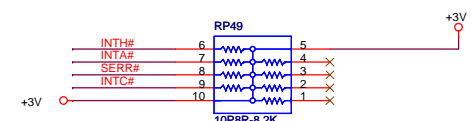
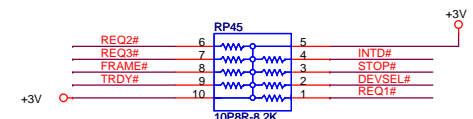
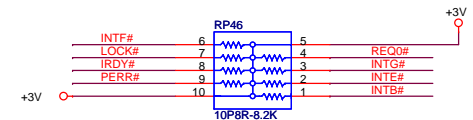
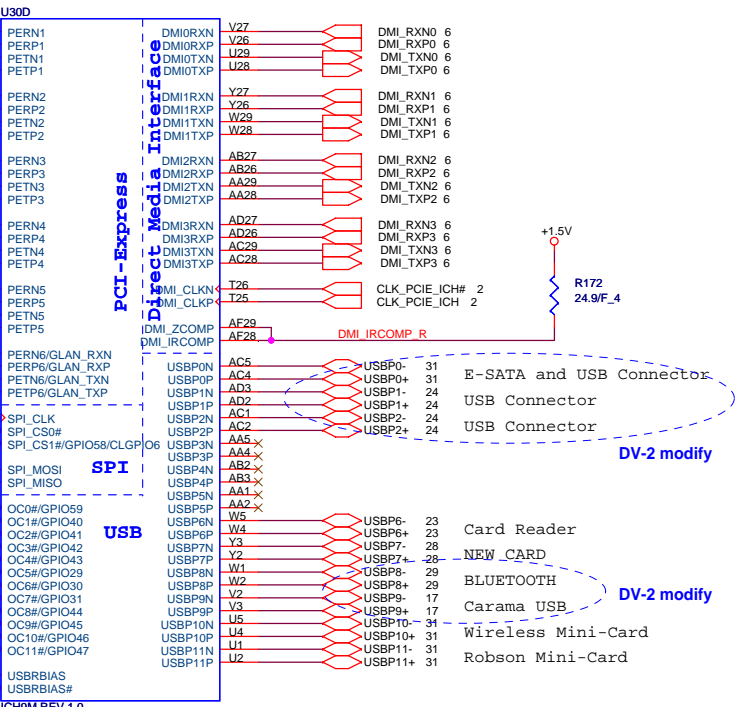
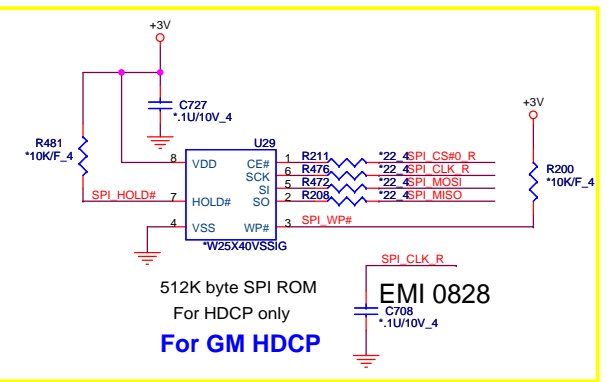
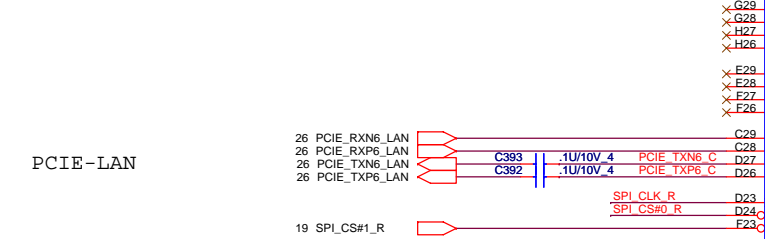
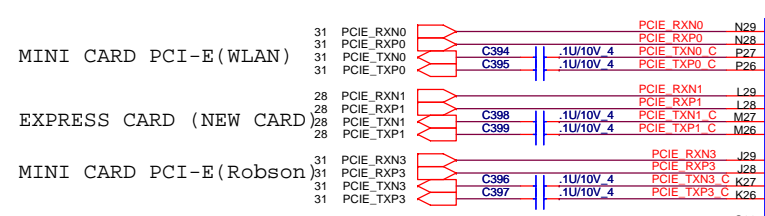

4, 9, 19, 20, 22, 24, 25, 28, 31, 34, 38 +1.5V
 2, 4, 6, 9, 10, 11, 12, 14, 15, 17, 18, 19, 20, 22, 24, 25, 26, 28, 29, 30, 31, 35, 36, 38 +3V
 19, 20, 22, 28, 38 +3VS5
 23, 29, 31, 34, 35, 36, 38 +3VSUS



BIOS_REC:BOARD_ID2
 Default is PH
 For Bios recovery PD

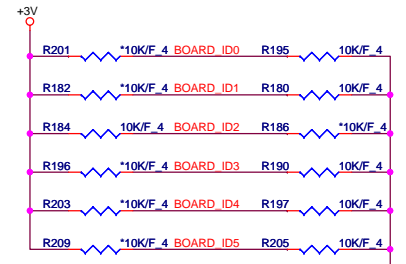
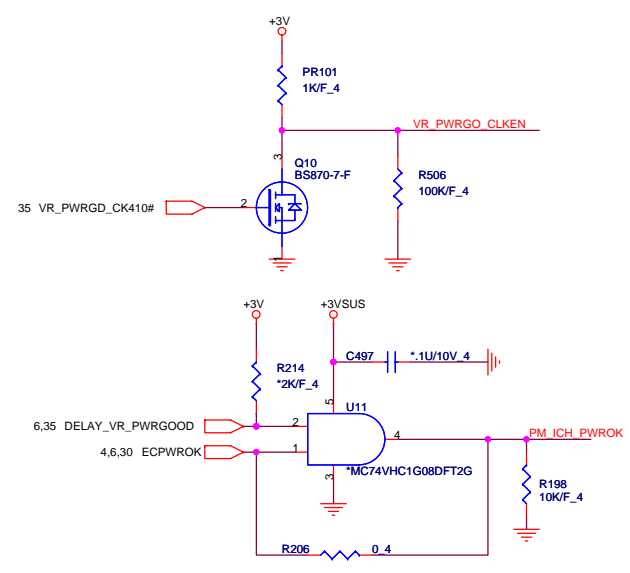
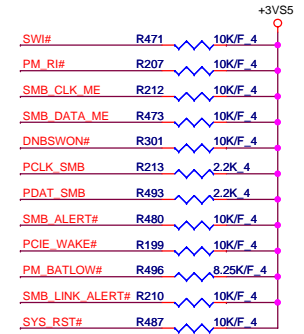
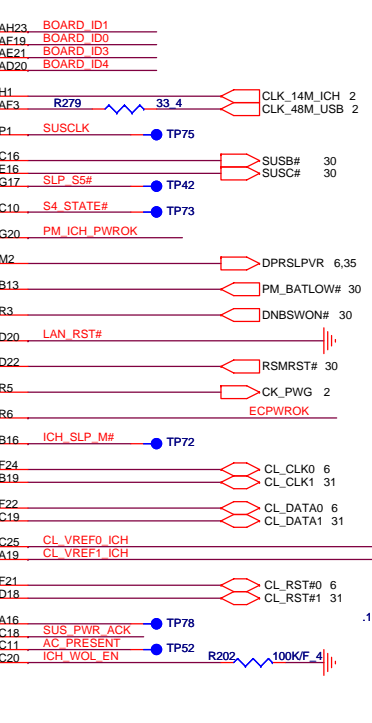
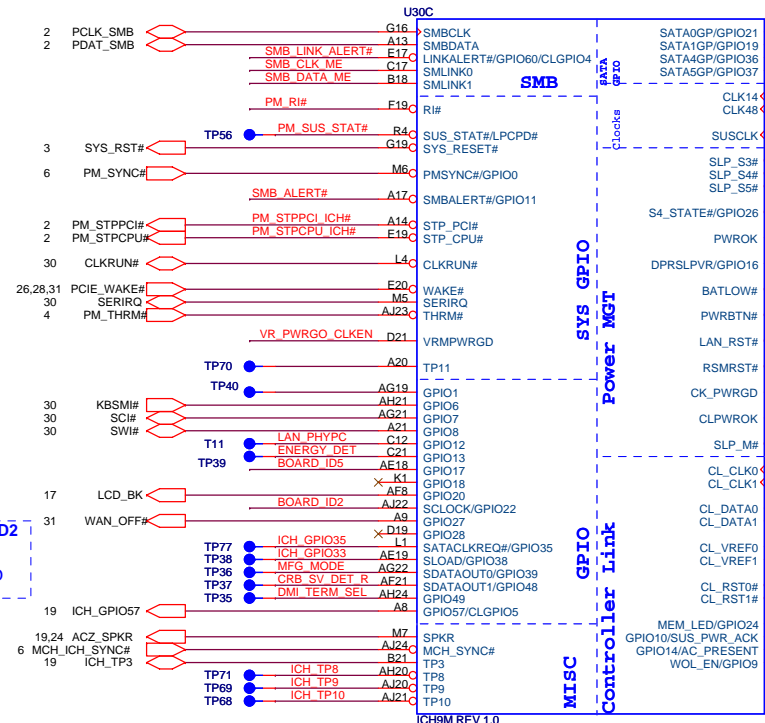

Board ID 4/5 pull low

Model	Board ID 3	Board ID 2	Board ID 1	Board ID 0
QL8/GM	0	0	0	0
QL8/9M	0	0	0	1
QL8/9P	0	0	1	0
QL6/GM	0	0	1	1
QL6/9M	0	1	0	0
TW8/GM	0	1	0	1
TW8/9M	0	1	1	0
TW8/9P	0	1	1	1
SW8/GM	1	0	0	0
SW8/9M	1	0	0	1
DW8/GM	1	0	1	0

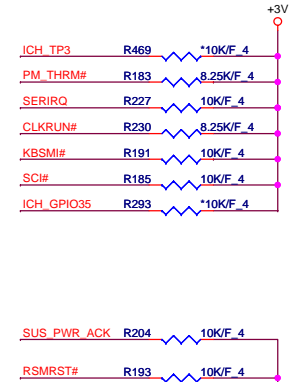

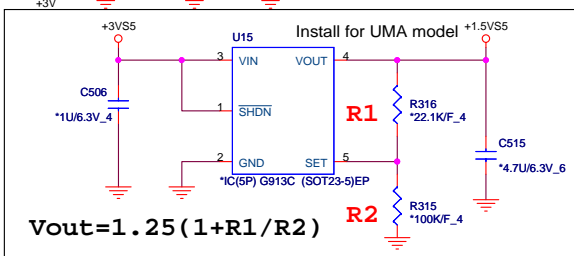
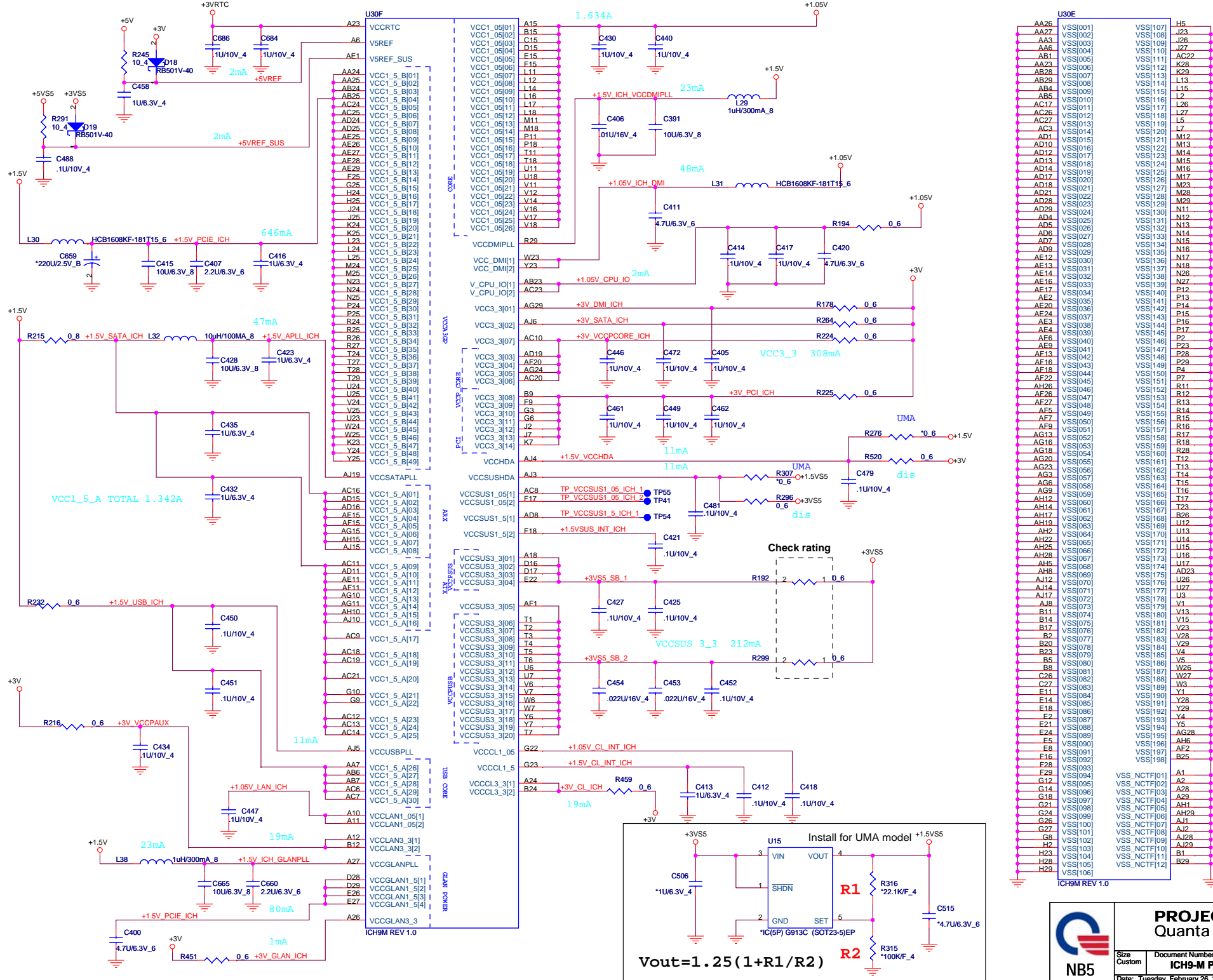

U30E

AA26	VSS1001	VSS107	H5
AA27	VSS1002	VSS108	J23
AA3	VSS1003	VSS109	J26
AA6	VSS1004	VSS110	K28
AB1	VSS1005	VSS111	K22
AA23	VSS1006	VSS112	AC22
AB28	VSS1007	VSS113	K29
AB29	VSS1008	VSS114	L13
AB4	VSS1009	VSS115	L2
AC17	VSS1010	VSS116	L26
AC17	VSS1011	VSS117	L25
AC26	VSS1012	VSS118	L27
AC27	VSS1013	VSS119	L5
AC3	VSS1014	VSS120	L7
AD10	VSS1015	VSS121	M12
AD10	VSS1016	VSS122	M13
AD12	VSS1017	VSS123	M14
AD13	VSS1018	VSS124	M15
AD14	VSS1019	VSS125	M16
AD17	VSS1020	VSS126	M17
AD18	VSS1021	VSS127	M23
AD21	VSS1022	VSS128	M28
AD28	VSS1023	VSS129	M29
AD29	VSS1024	VSS130	N11
AD6	VSS1025	VSS131	N12
AD5	VSS1026	VSS132	N13
AD6	VSS1027	VSS133	N14
AD7	VSS1028	VSS134	N15
AD9	VSS1029	VSS135	N16
AE12	VSS1030	VSS136	N17
AE13	VSS1031	VSS137	N18
AE14	VSS1032	VSS138	N26
AE16	VSS1033	VSS139	N27
AE17	VSS1034	VSS140	P12
AE2	VSS1035	VSS141	P13
AE20	VSS1036	VSS142	P14
AE24	VSS1037	VSS143	P15
AE3	VSS1038	VSS144	P16
AE4	VSS1039	VSS145	P17
AE9	VSS1040	VSS146	P2
AF1	VSS1041	VSS147	P22
AF13	VSS1042	VSS148	P28
AF16	VSS1043	VSS149	P29
AF18	VSS1044	VSS150	P7
AF22	VSS1045	VSS151	P11
AH26	VSS1046	VSS152	R11
AF26	VSS1047	VSS153	R12
AF27	VSS1048	VSS154	R13
AF5	VSS1049	VSS155	R14
AF7	VSS1050	VSS156	R15
AF9	VSS1051	VSS157	R16
AG13	VSS1052	VSS158	R17
AG16	VSS1053	VSS159	R18
AG18	VSS1054	VSS160	R28
AG18	VSS1055	VSS161	R28
AG20	VSS1056	VSS162	T12
AG3	VSS1057	VSS163	T14
AG6	VSS1058	VSS164	T15
AH12	VSS1059	VSS165	T16
AH14	VSS1060	VSS166	T17
AH14	VSS1061	VSS167	T18
AH17	VSS1062	VSS168	U2
AH19	VSS1063	VSS169	B26
AH2	VSS1064	VSS170	U13
AH22	VSS1065	VSS171	U14
AH25	VSS1066	VSS172	U15
AH28	VSS1067	VSS173	U16
AH5	VSS1068	VSS174	U17
AH8	VSS1069	VSS175	AD23
AH12	VSS1070	VSS176	U26
AH14	VSS1071	VSS177	U27
AH17	VSS1072	VSS178	U3
AH8	VSS1073	VSS179	V1
B11	VSS1074	VSS180	V13
B14	VSS1075	VSS181	V15
B17	VSS1076	VSS182	V23
B2	VSS1077	VSS183	V28
B20	VSS1078	VSS184	V29
B23	VSS1079	VSS185	V4
B5	VSS1080	VSS186	V5
B8	VSS1081	VSS187	W6
C26	VSS1082	VSS188	W27
C27	VSS1083	VSS189	W3
E11	VSS1084	VSS190	Y1
E14	VSS1085	VSS191	Y28
E18	VSS1086	VSS192	AC28
E2	VSS1087	VSS193	Y4
E21	VSS1088	VSS194	Y5
E24	VSS1089	VSS195	AF2
E5	VSS1090	VSS196	AH6
F8	VSS1091	VSS197	AF28
F16	VSS1092	VSS198	B25
F28	VSS1093		A1
F29	VSS1094	VSS_NCTF[01]	A2
G12	VSS1095	VSS_NCTF[02]	A28
G14	VSS1096	VSS_NCTF[03]	A29
G18	VSS1097	VSS_NCTF[04]	AH1
G21	VSS1098	VSS_NCTF[05]	AH29
G24	VSS1099	VSS_NCTF[06]	AJ1
G26	VSS1100	VSS_NCTF[07]	AJ2
G27	VSS1101	VSS_NCTF[08]	AJ28
H2	VSS1102	VSS_NCTF[09]	AJ29
H23	VSS1103	VSS_NCTF[10]	B1
H23	VSS1104	VSS_NCTF[11]	B29
H28	VSS1105	VSS_NCTF[12]	
H29	VSS1106		

PROJECT : QL6
Quanta Computer Inc.

NB5

Size: Custom	Document Number: ICH9-M Power 4/4	Rev: 2A
Date: Tuesday, February 26, 2008	Sheet: 22	of 40

Note:

SD/MMC	MS	XD
SP0		XD CD#
SP1	SD WP	XD CD#
SP2	SD CD#	
SP3	SD CD#	
SP4	SD DAT1	XD D4
SP5	MS BS	XD D5
SP6	SD DAT1	MS D1
SP7	SD DAT0	MS D0
SP8	SD DAT7	MS D2
SP9	MS INS#	
SP10	SD DAT6	MS D3
SP11	SD CLK	MS SCLK
SP12	SD DAT5	XD D0
SP13	SD DAT4	XD WP#
SP14	SD DAT4	XD R/B#
SP15	SD DAT3	XD WE#
SP16	SD DAT2	XD RE#
SP17		XD ALE
SP18		XD CE#
SP19		XD CLE

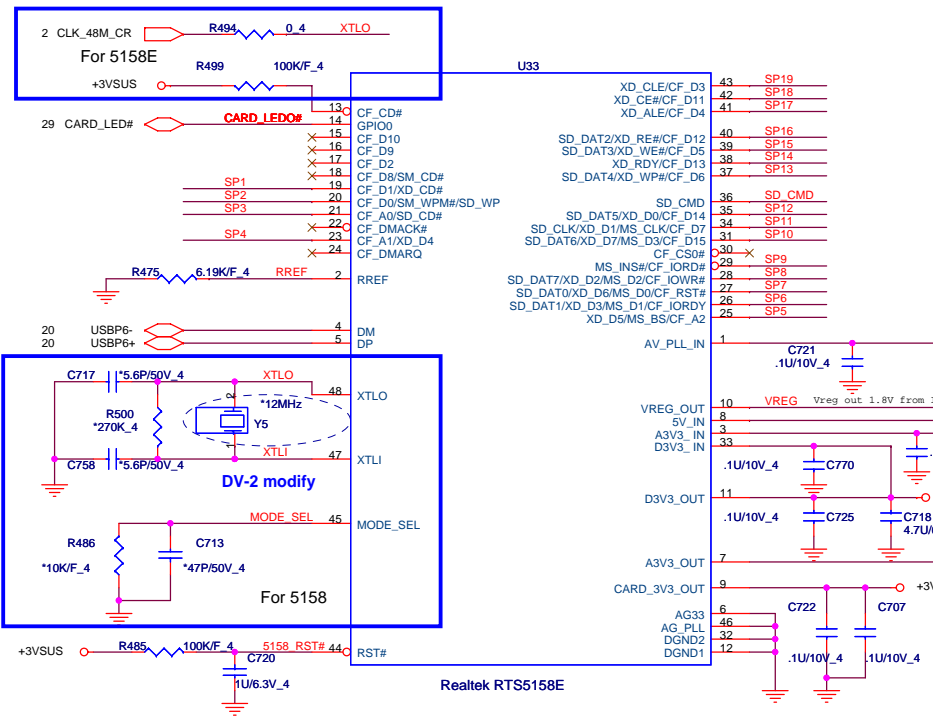
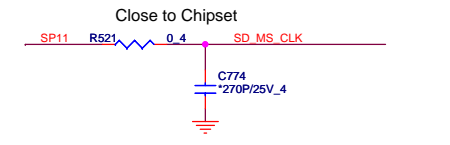
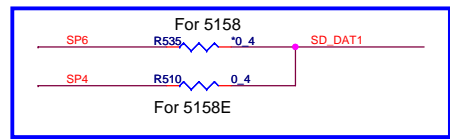

5 IN1 CARD READER
XD, MMC/SD, MS/MSP

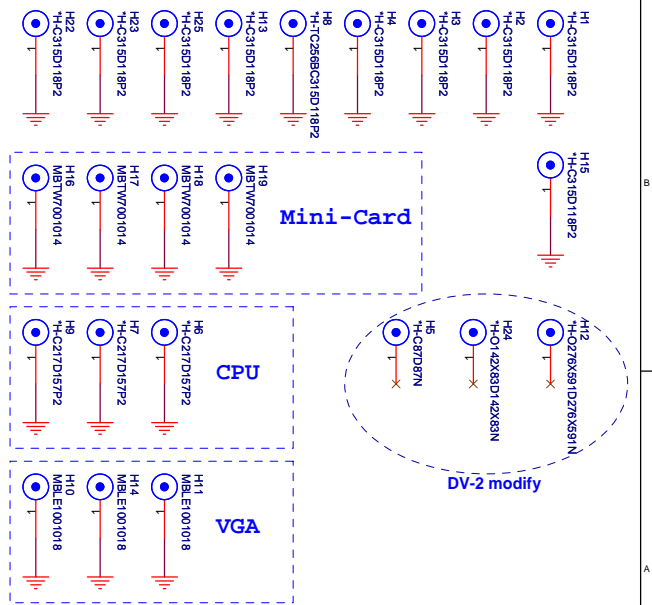
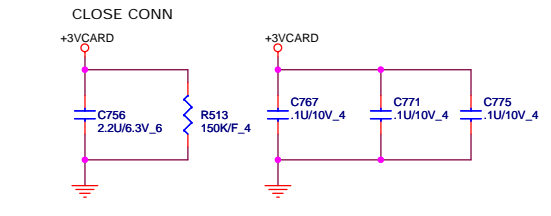
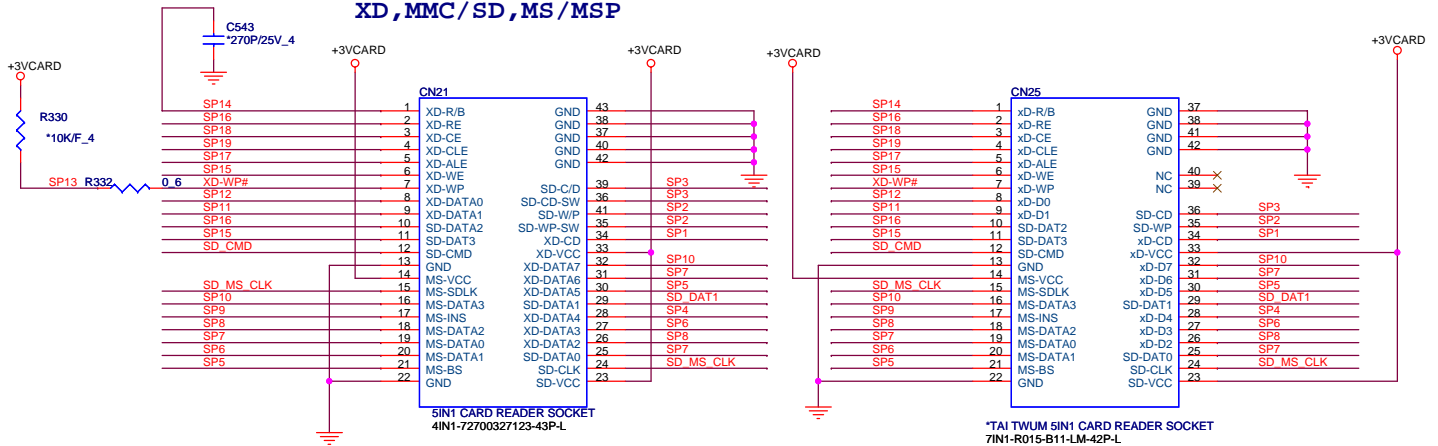

PROJECT : QL6
Quanta Computer Inc.

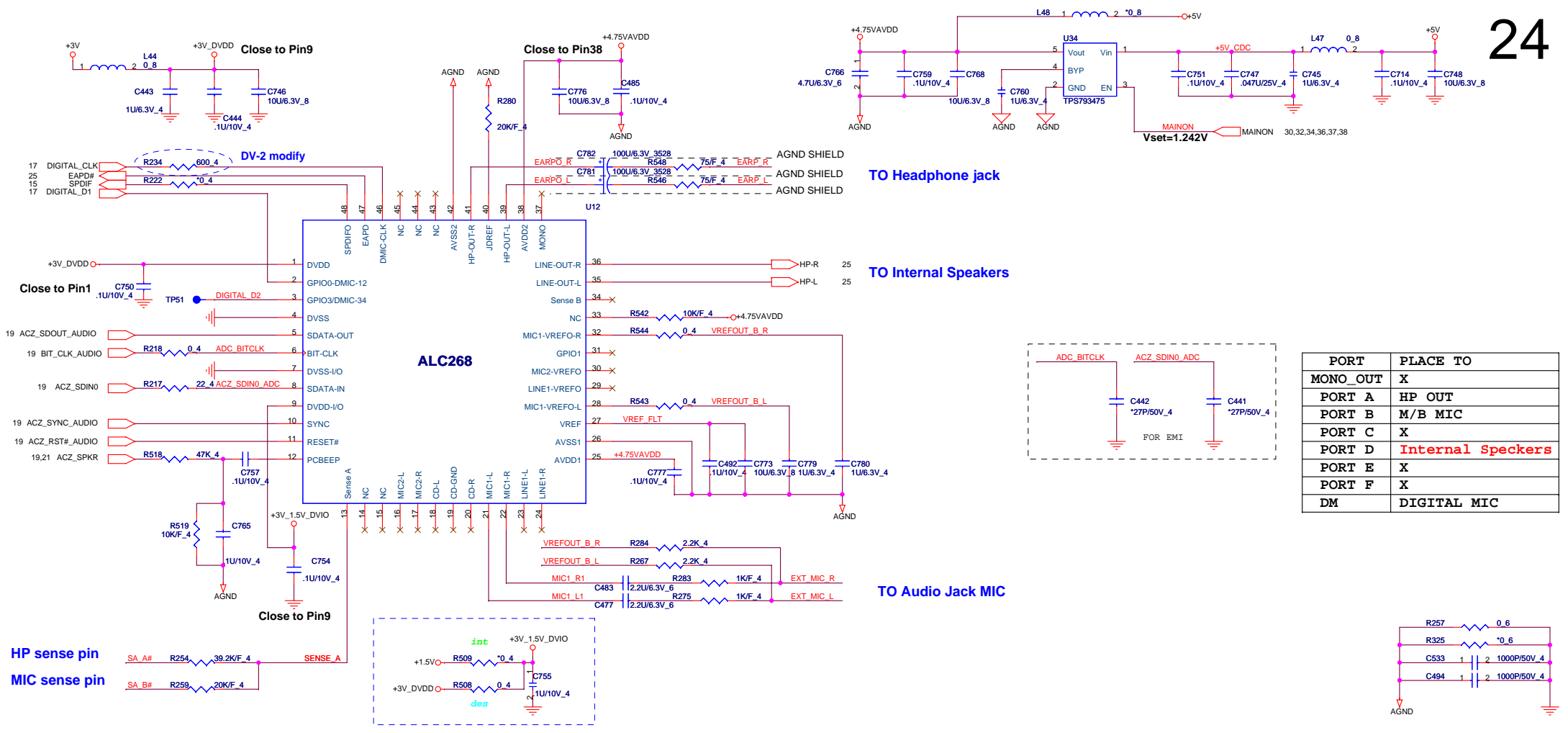

TO Headphone jack

TO Internal Speakers

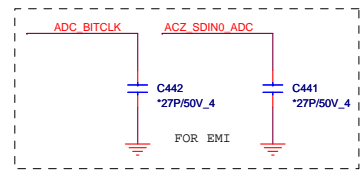

PORT	PLACE TO
MONO_OUT	X
PORT A	HP OUT
PORT B	M/B MIC
PORT C	X
PORT D	Internal Speakers
PORT E	X
PORT F	X
DM	DIGITAL MIC

TO Audio Jack MIC

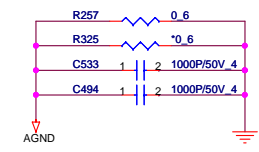

AUDIO/USB BOARD CONNECTOR

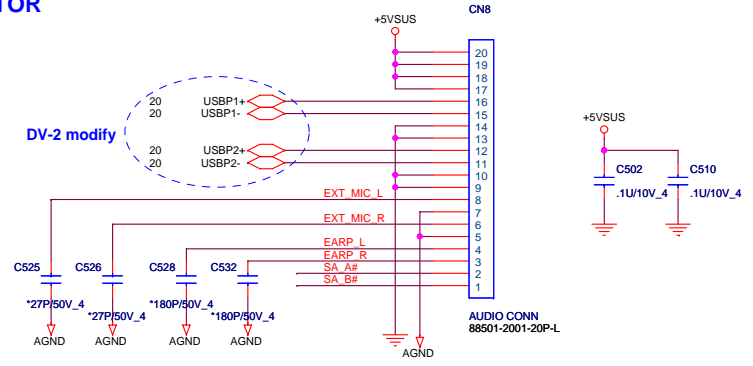

PROJECT : QL6
Quanta Computer Inc.

Size Custom	Document Number Azalia IDT92HD71B7	Rev 2A
Date: Tuesday, February 26, 2008 Sheet 24 of 40		

AUDIO AMPLIFIER

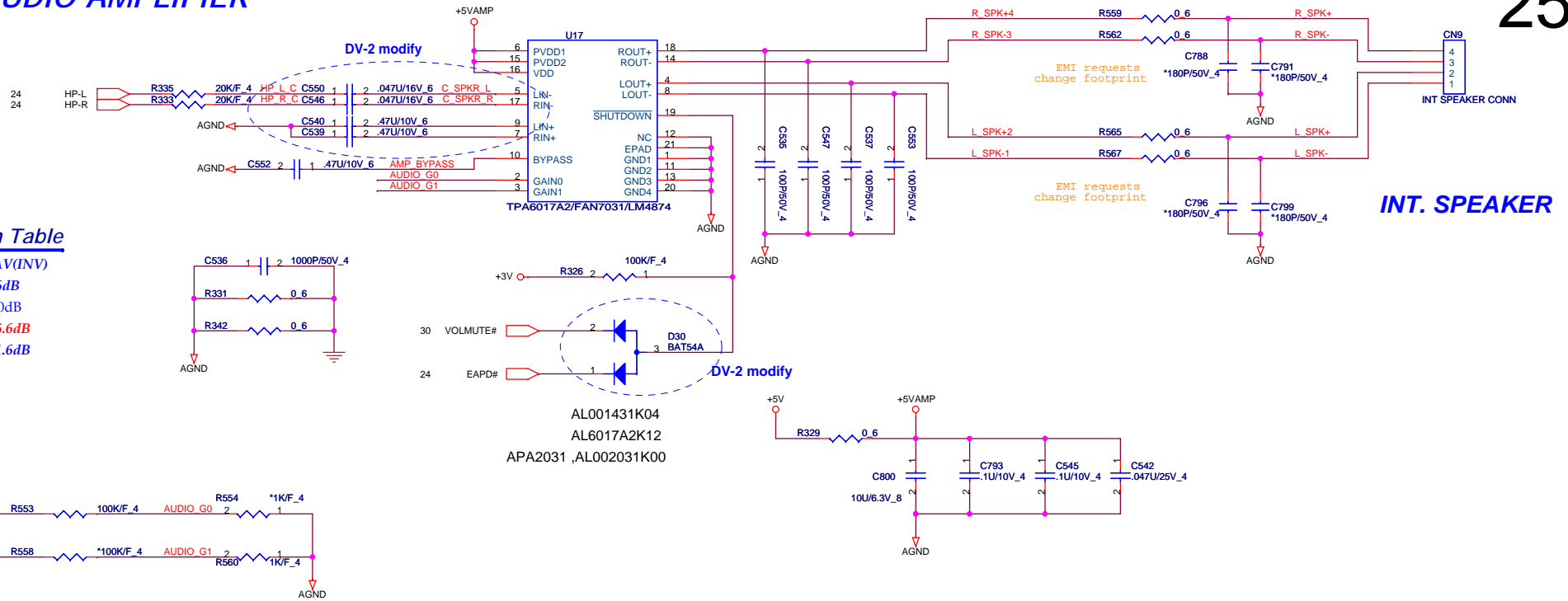

6017A2 Gain Table

GAIN0	GAIN1	AV(INV)
0	0	6dB
0	1	10dB
1	0	15.6dB
1	1	21.6dB

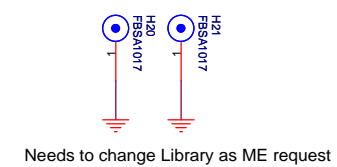
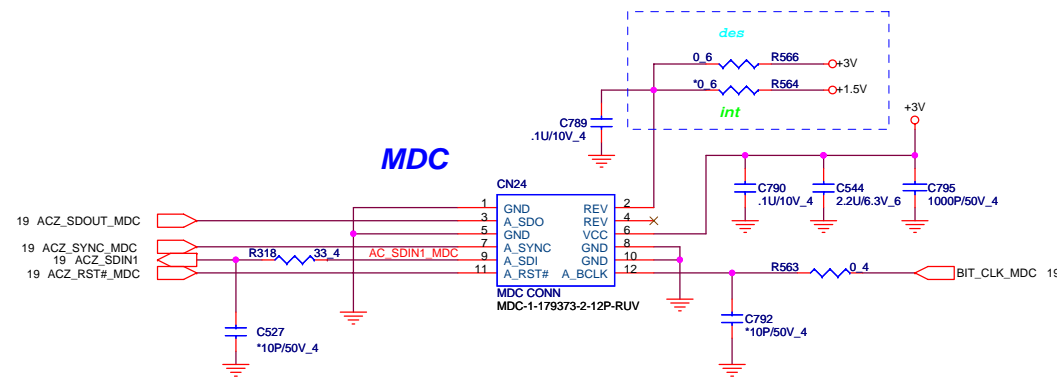
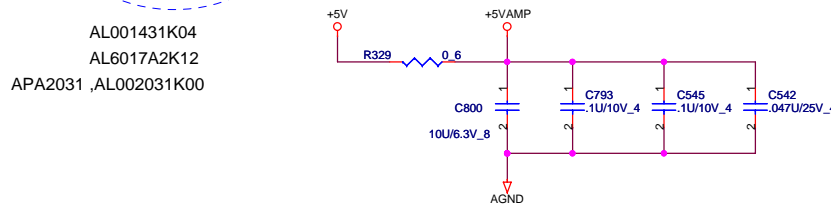
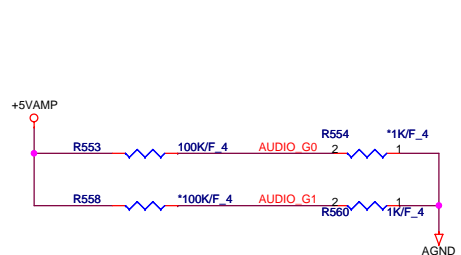
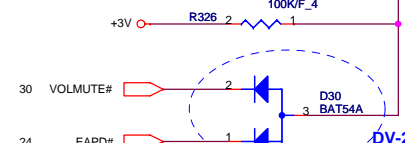
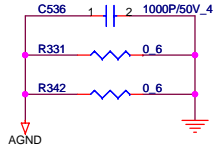

PROJECT : QL6
Quanta Computer Inc.

Size Custom	Document Number AMP_TPA6017/MDC	Rev 2A
Date: Tuesday, February 26, 2008 Sheet 25 of 40		

T : Stuffed for RTL8111C(10/100/1000)

E : Stuffed for 8102E(10/100)

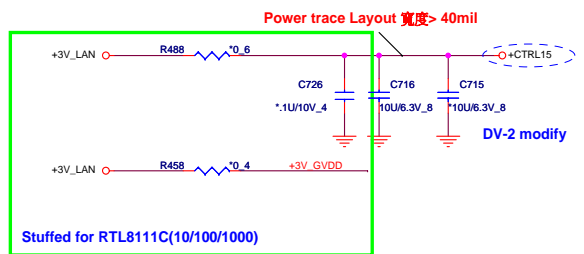
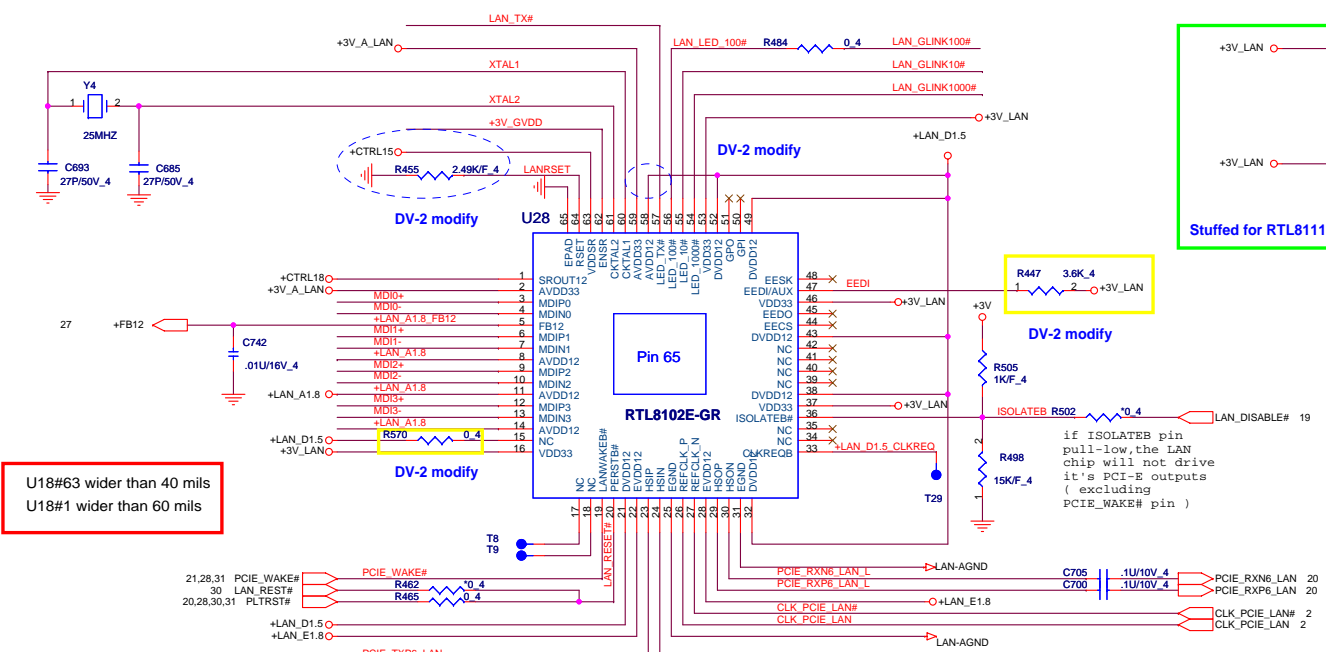
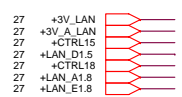

U18#63 wider than 40 mils
U18#1 wider than 60 mils

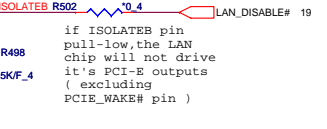
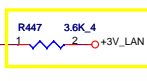

AL08111C001 IC CTRL(64P) RTL8111C-VB-GR(QFN)
AL08102E001 IC CTRL(64P) RTL8102E-GR(QFN)

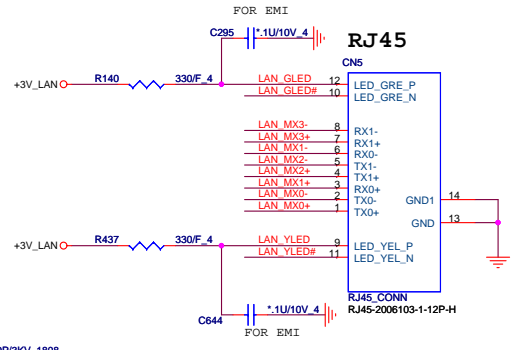
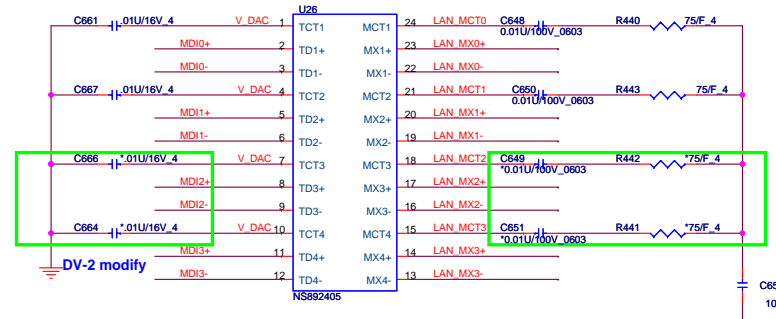
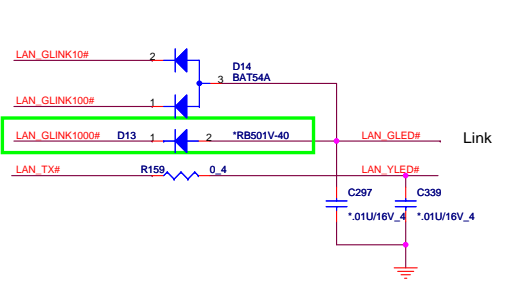

NS892402:GIGABIT DB0AT9LAN05
NS892405:10/100 DB0ZB1LAN04

PROJECT : QL6
Quanta Computer Inc.
NB5
Size Custom Document Number RTL8111C/8101E/RJ45 Rev 2A
Date: Tuesday, February 26, 2008 Sheet 26 of 40

- T : Stuffed for RTL8111C(10/100/1000)
- E : Stuffed for 8102E(10/100)
- other

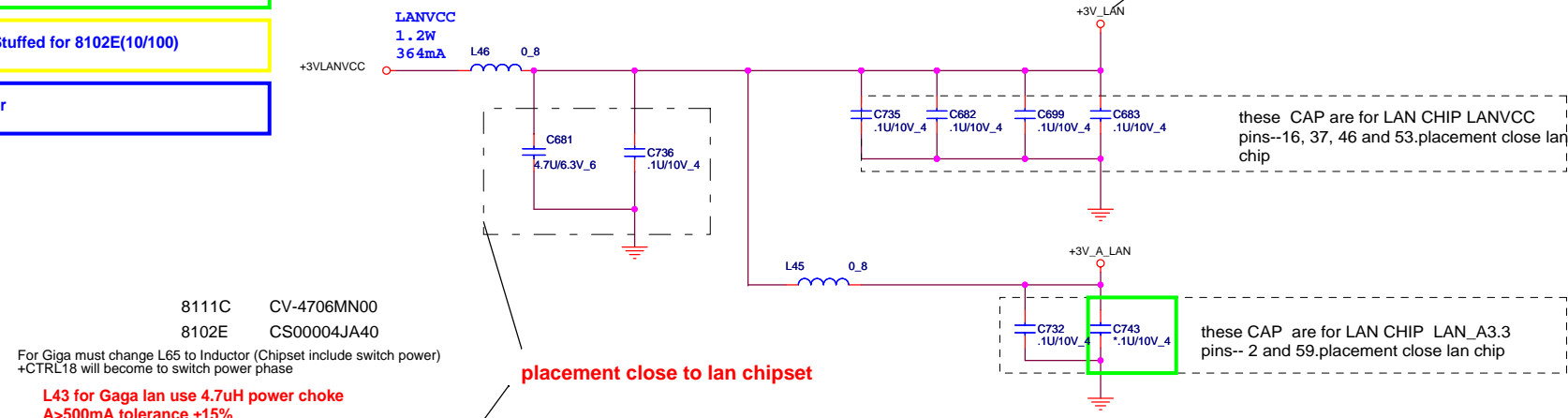

8111C CV-4706MN00
 8102E CS00004JA40

For Giga must change L65 to inductor (Chipset include switch power)
 +CTRL18 will become to switch power phase

L43 for Giga lan use 4.7uH power choke
 A>500mA tolerance ±15%

placement close to lan chipset

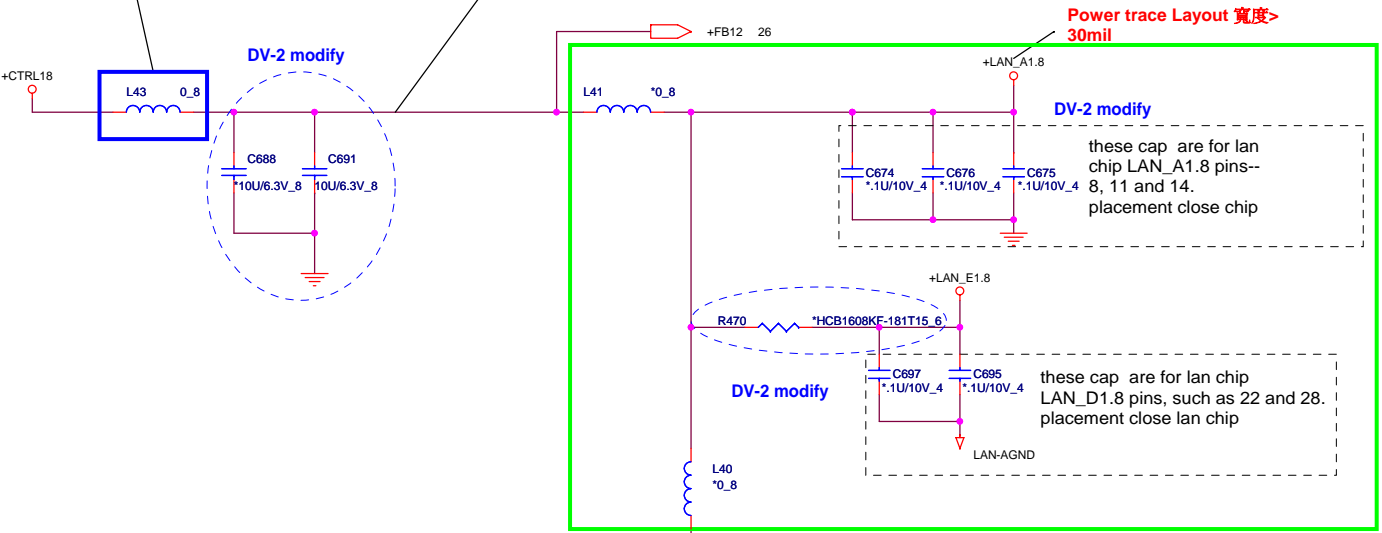

Power domain chart

	RTL8111C / RTL8102E
LANVCC	3.3V
LAN_D1.8	1.2V
LAN_A1.8	1.2V
LAN_D1.5	1.2V

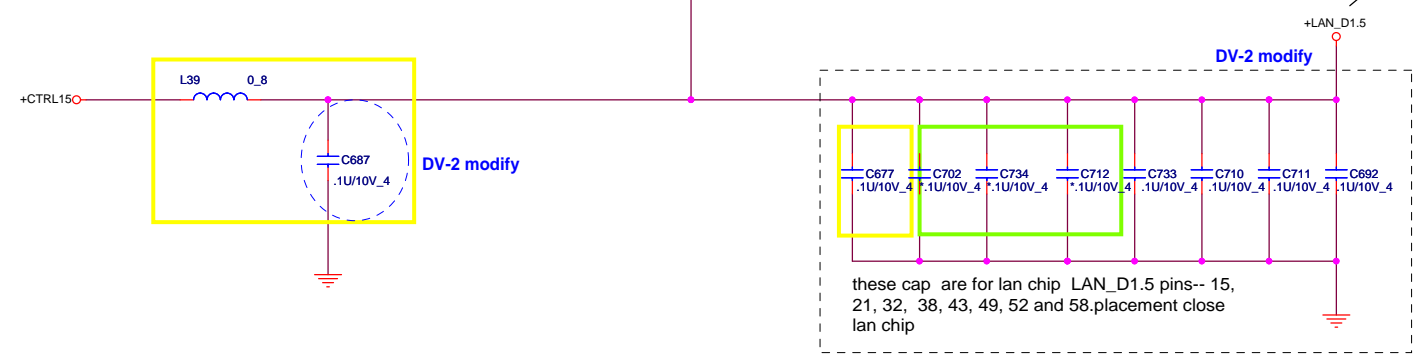

PROJECT : QL6
 Quanta Computer Inc.

Size A3	Document Number LAN Power	Rev 2A
Date: Tuesday, February 26, 2008 Sheet 27 of 40		

SATA ODD CONECTOR

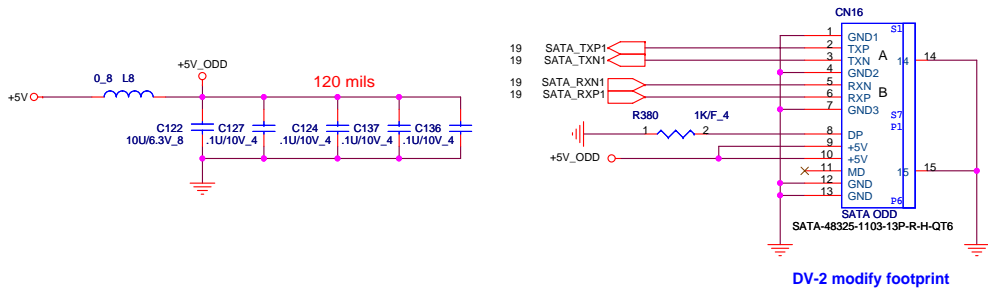

SATA HDD CONNECTOR

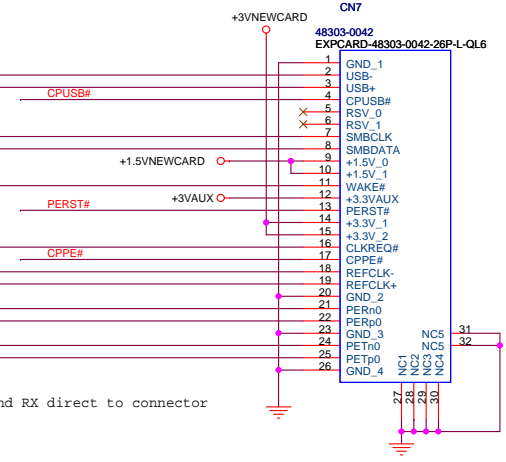
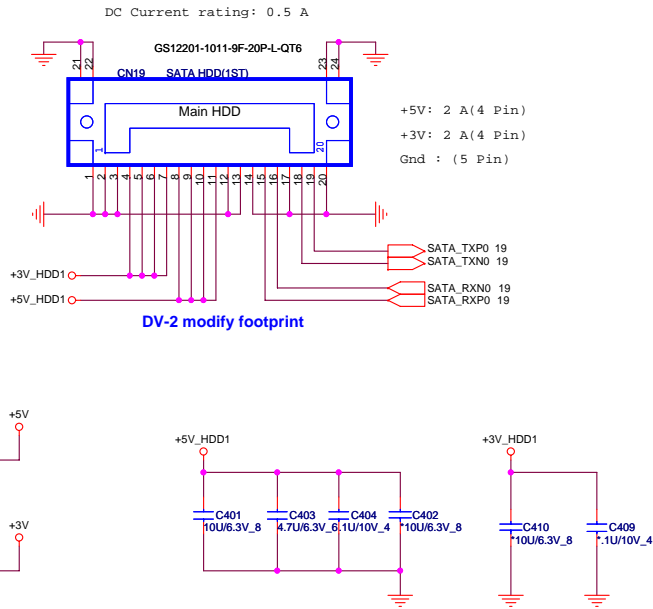

EXPCARD-48303-0042-26P-L-QT6 as ME modify Pad size(pin31,32)
DV-2 modify

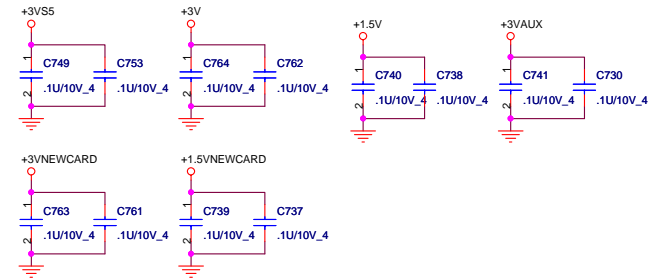
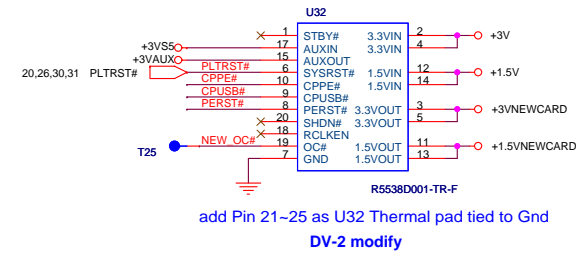

	<p>PROJECT : QL6 Quanta Computer Inc.</p>		<p>Rev 2A</p>
	<p>Size Custom</p>	<p>Document Number ODD/HDD/NEW CARD</p>	

BLUETOOTH POWER

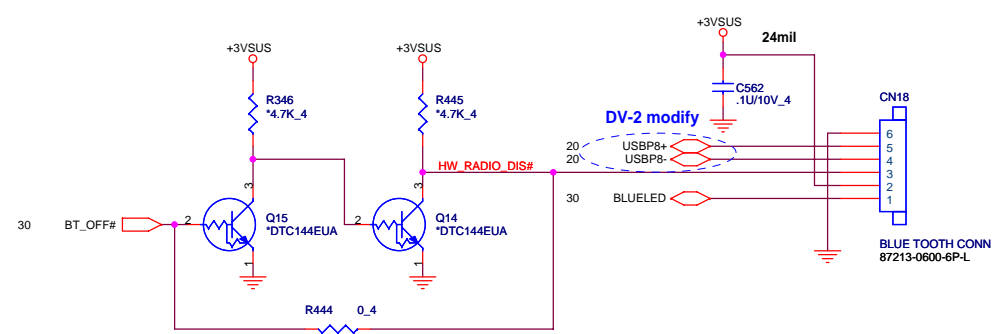

POWER BUTTON CONNECT

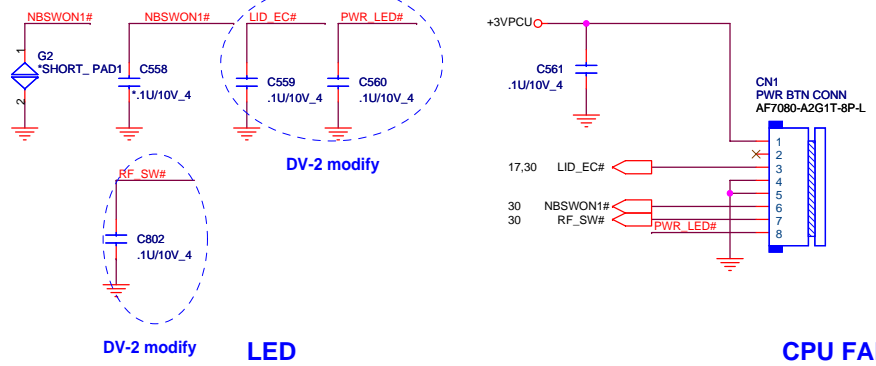

1. +3VPCU
2. N/A
3. LIDSWITCH
4. GND
5. GND
6. POWERON#
7. RF_SW#
8. PWRLED#

CPU FAN

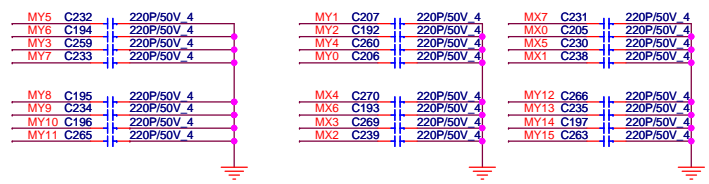
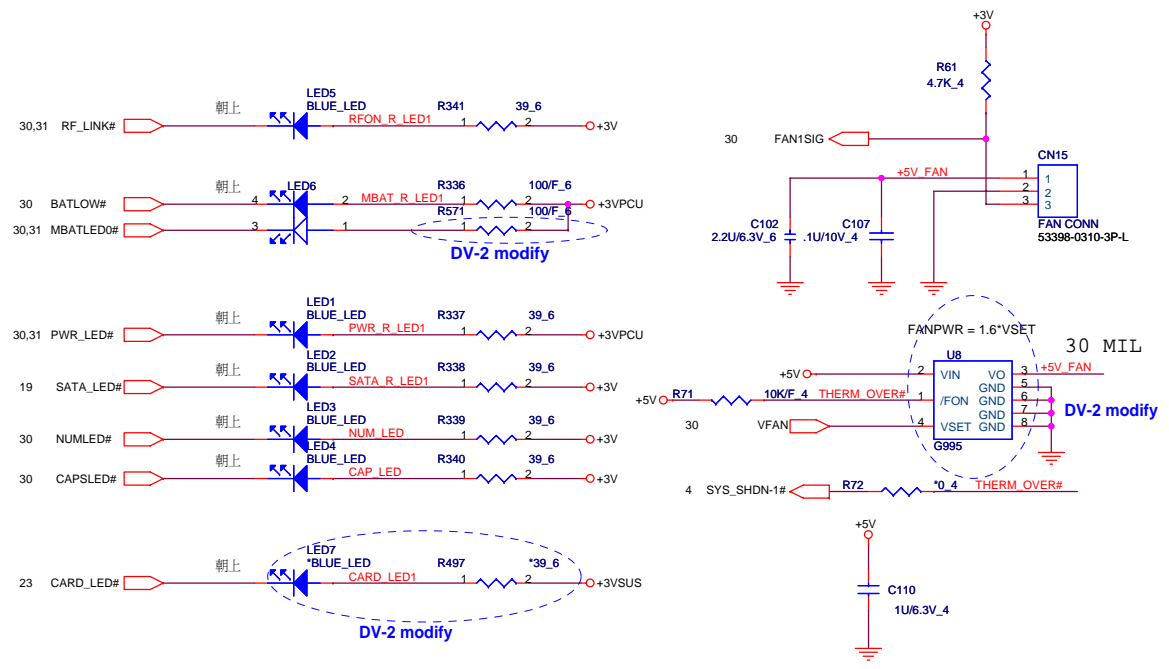

KEYBOARD PULL-UP

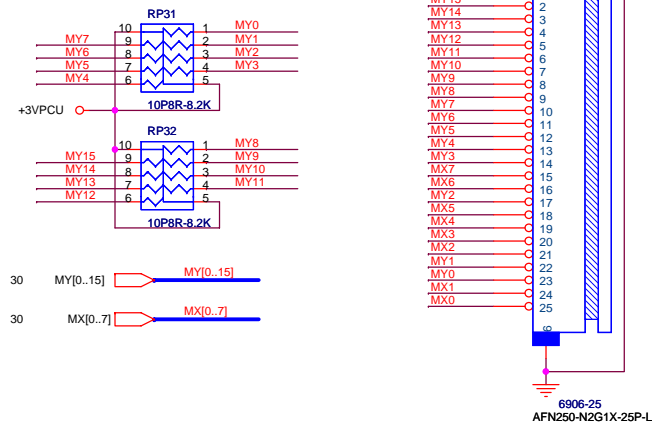

25	129	33	113	59	46	36	91	118	119		12	102	124
	App	D	F2	Fn	Z	H	num 7	F7	F8		num 6	num 6	Prt
24	17	104	115	112	99	48	22	122	117	120	108	123	125
	Q	num Del	F4	F1	num 0	Y	F11	F10	F9	F6	num Ent	F12	Scr
	1		31	110	93	6	7	121	116	42	11	13	76
	,		#/3	Esc	% 5	^ 6	F10	F5	~ #	0	+ =	13	80
20	19	4	4	3	98	5	8	10	45	58	26	15	86
	E		@ 2	num 2	\$ 4	& 7	(9	* 8	! \	L Ctrl	P	BS	Home
19	16	Tab	1	18	83	20	23	25	24	92	27	28	86
			! 1	R	C	R	U	J	L Shift	num 4	[[]]	PgDn
18	30	30	114	32	103	34	37	39	44	38	79	40	85
	Caps		F3	S	num 3	F	U	L Shift	K	num 4	79	40	85
16	96	62	35	47	84	49	52	54	53	101	55	41	81
	num 8	R Alt	G	X	V	O	Q	U	<	num 9	? /	num 8	End
15	56	60	97	21	90	50	51	95	100	89	105	43	61
	? /	L Alt	num 5	T	num Lk	B	N	num /	num *	num *	num -	Ent	Space

1&17 pin short circuit

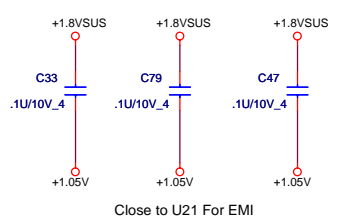

PROJECT : QL6
Quanta Computer Inc.

Size Custom	Document Number KB/FAN/POWER CONN/LED	Rev 2A
Date: Tuesday, February 26, 2008 Sheet 29 of 40		

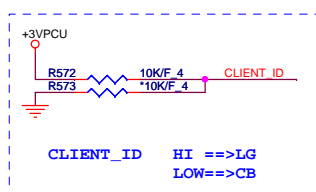
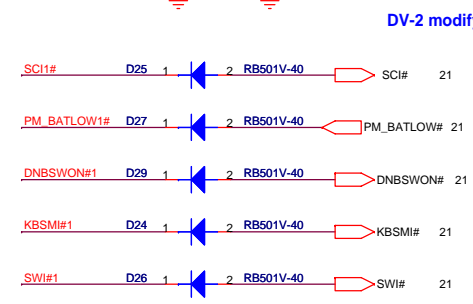
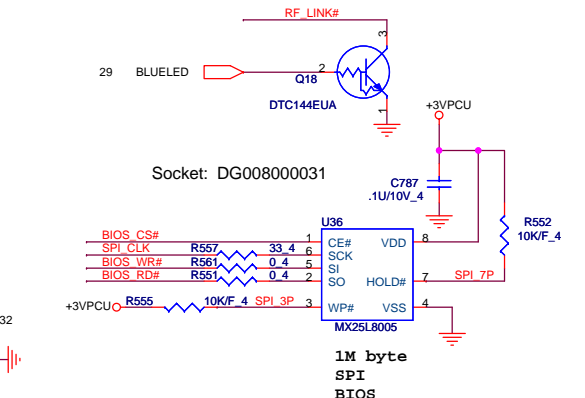
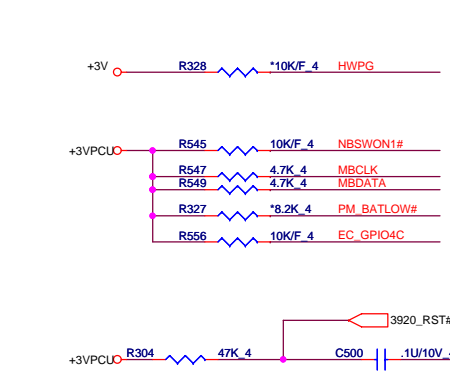
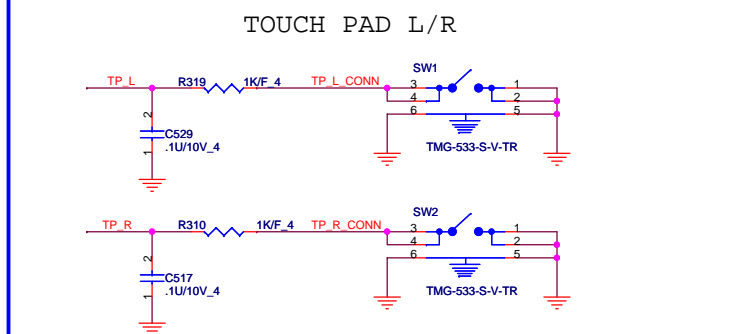
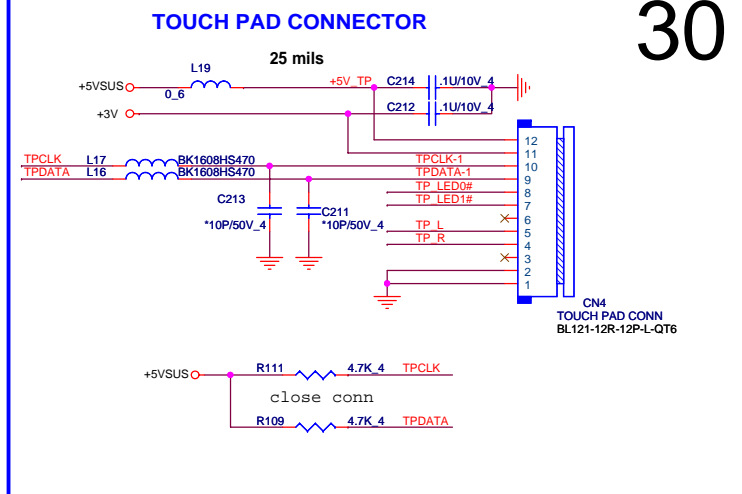
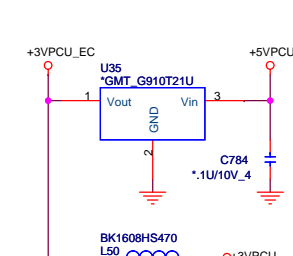
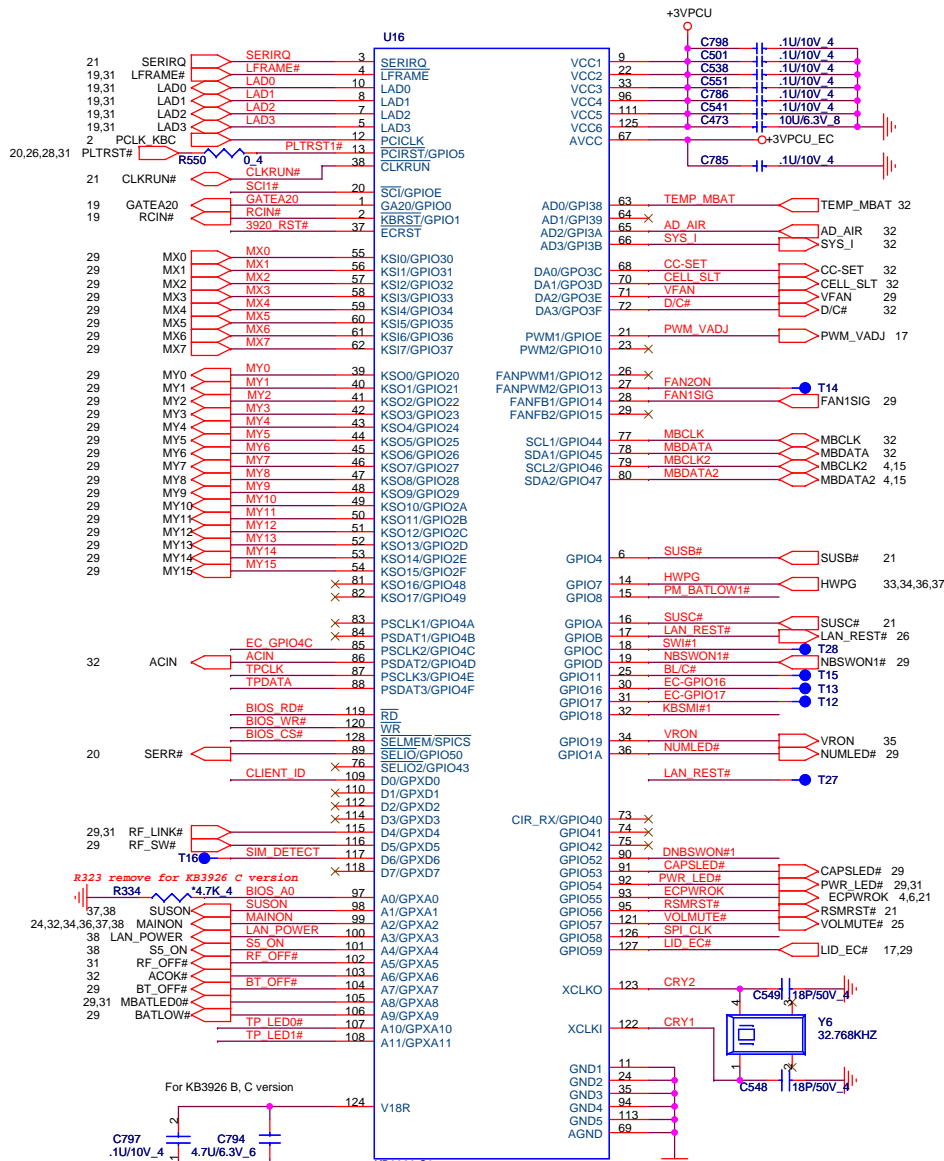

PROJECT : QL6
Quanta Computer Inc.

NB5

Size Custom	Document Number KB3926/ROM/TP	Rev 2A
Date: Tuesday, February 26, 2008		Sheet 30 of 40

Mini PCI-E Card 1 WLAN

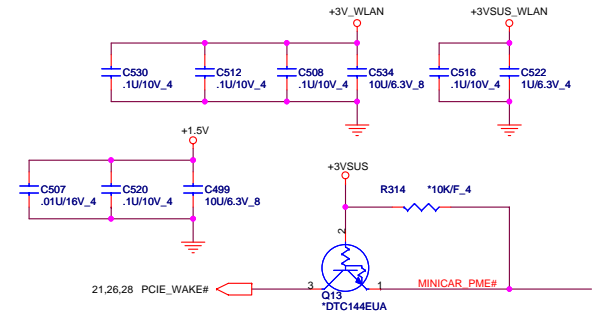
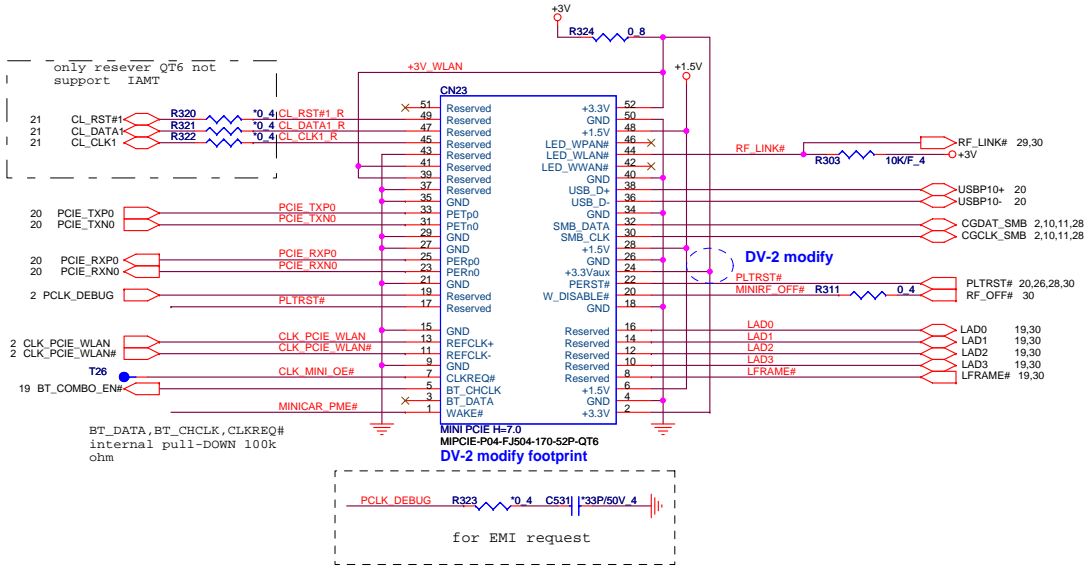

Mini PCI-E Card 2 ROBSON

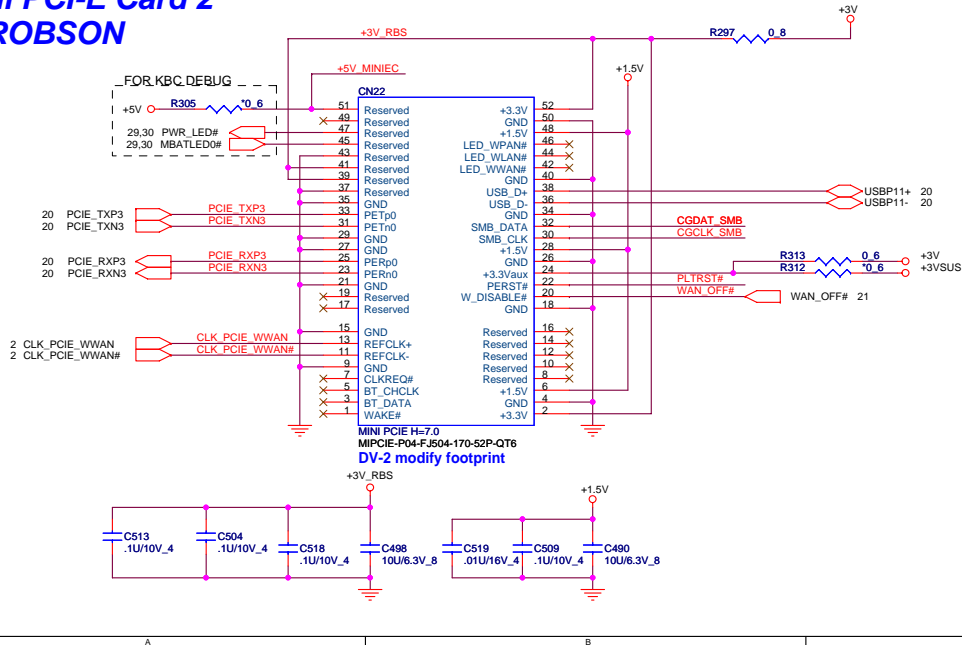

E-SATA/USB COMBO

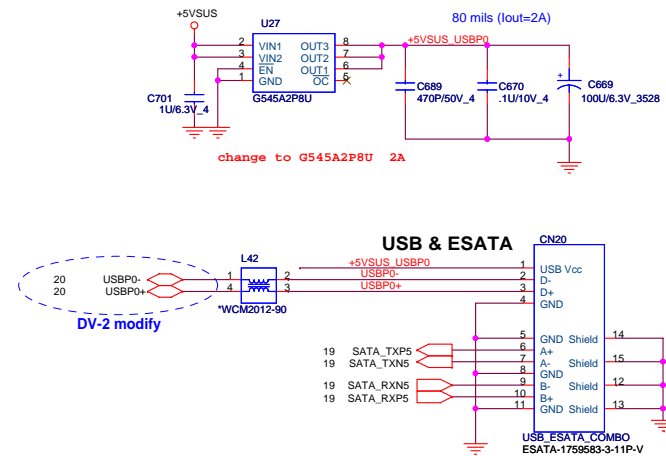

	PROJECT : QL6 Quanta Computer Inc.		Rev 2A
	Size Custom	Document Number MINI PCIE CONN X2/E-SATA	

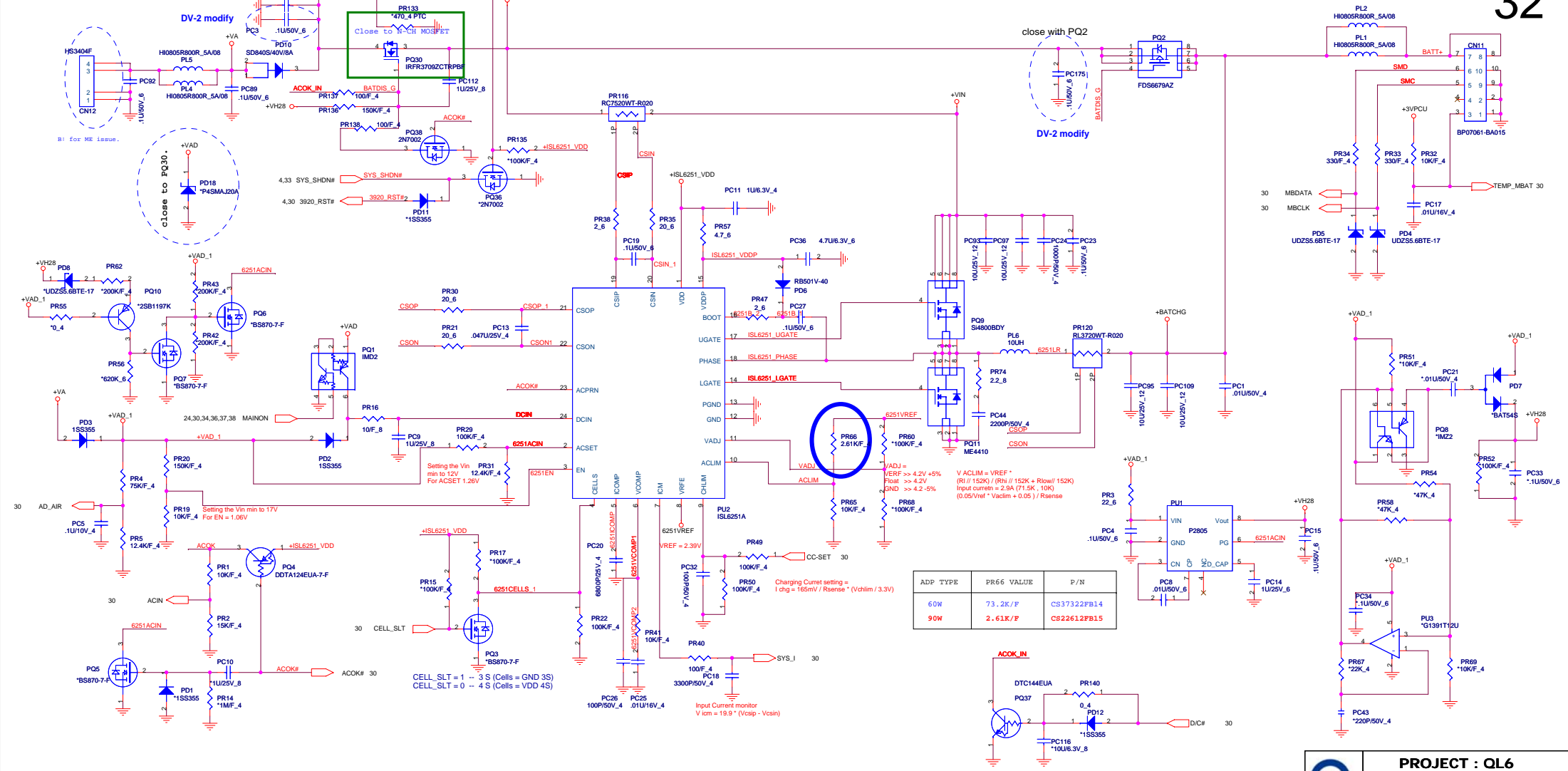

ADP TYPE	PR66 VALUE	P/N
60W	73.2K/F	CS37322FB14
90W	2.61K/F	CS22612FB15

PROJECT : QL6
Quanta Computer Inc.

Size Custom Document Number **Charger (ISL6251)** Rev 2A

Date: Tuesday, February 26, 2008 Sheet 32 of 40

5 Volt +/- 5%
 Countinue current:5A
 Peak current:7.5A
 OCP minimum 10A

3.3 Volt +/- 5%
 Countinue current:5A
 Peak current:7.5A
 OCP minimum 9A

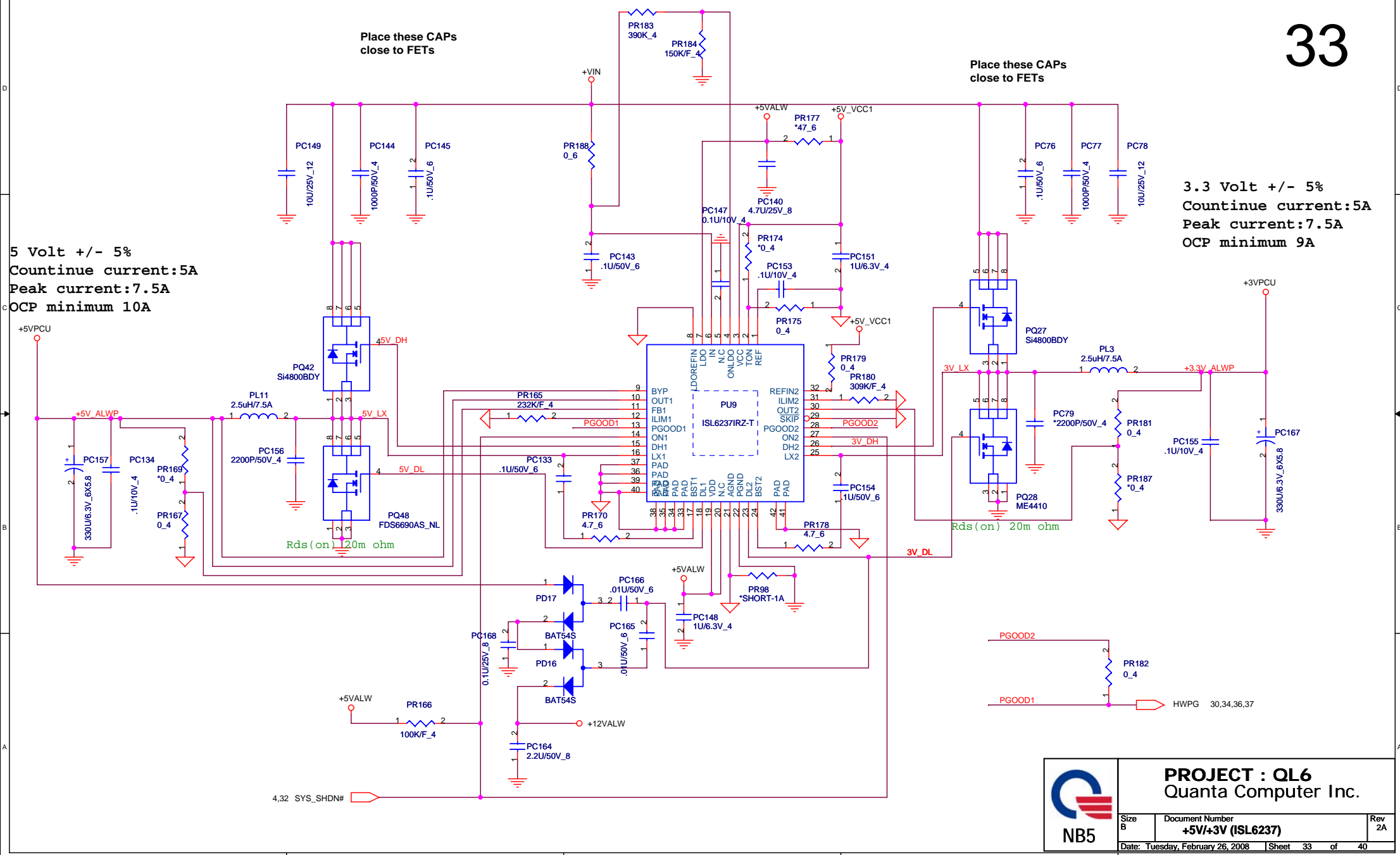

	PROJECT : QL6 Quanta Computer Inc.	
	Size B	Document Number +5V/+3V (ISL6237)
Date: Tuesday, February 26, 2008 Sheet 33 of 40		

VCCP1.05V & +1.5V

+1.05Volt +/- 5%
 Countinue current:7.5A
 Peak current:10A
 OCP minimum 15A

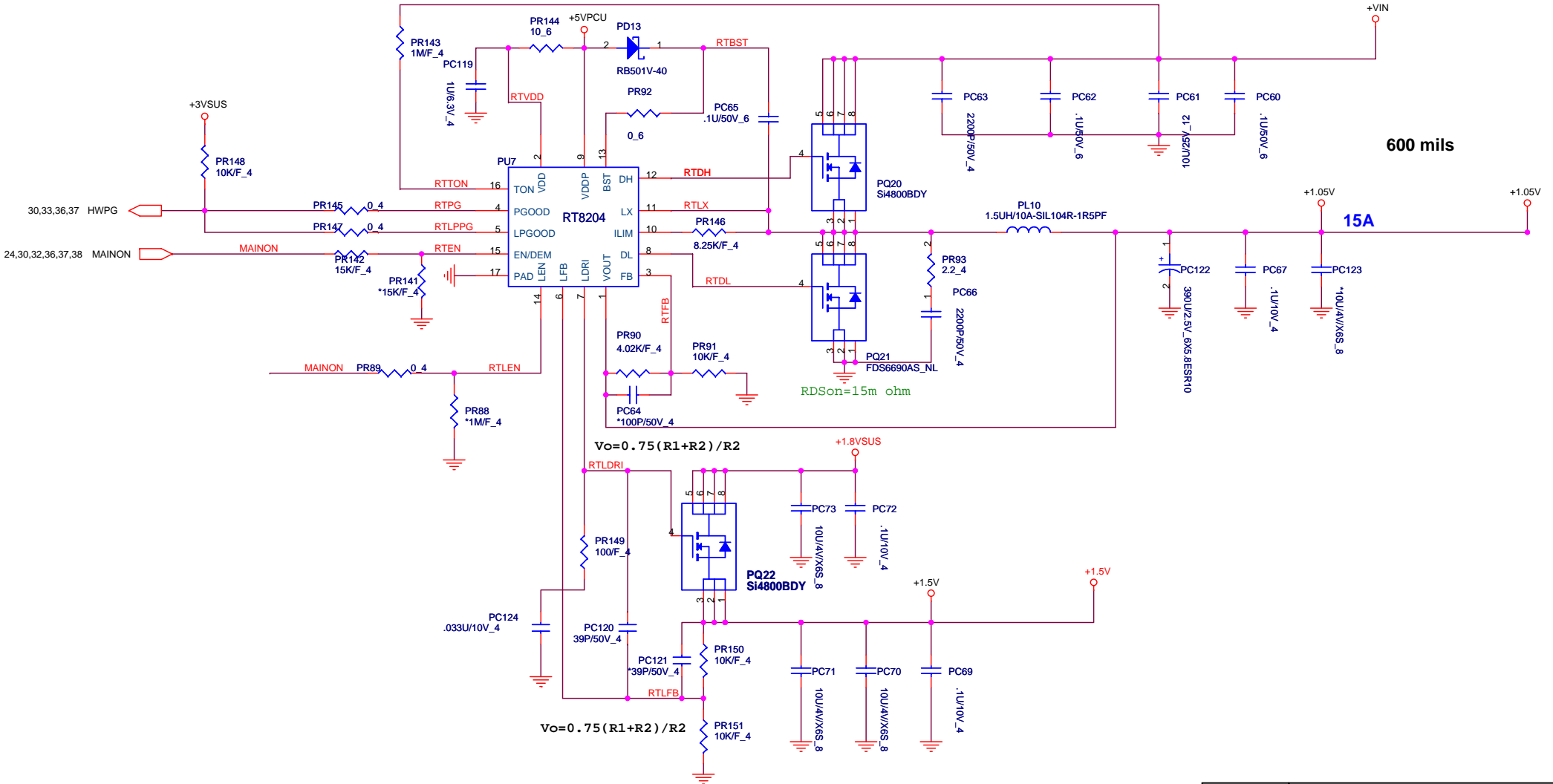

600 mils

15A

$$V_o = 0.75 \cdot (R_1 + R_2) / R_2$$

$$V_o = 0.75 \cdot (R_1 + R_2) / R_2$$



PROJECT : QL6
 Quanta Computer Inc.

Size B	Document Number +1.05V/+1.5V (RT8204)	Rev 2A
Date: Tuesday, February 26, 2008 Sheet 34 of 40		

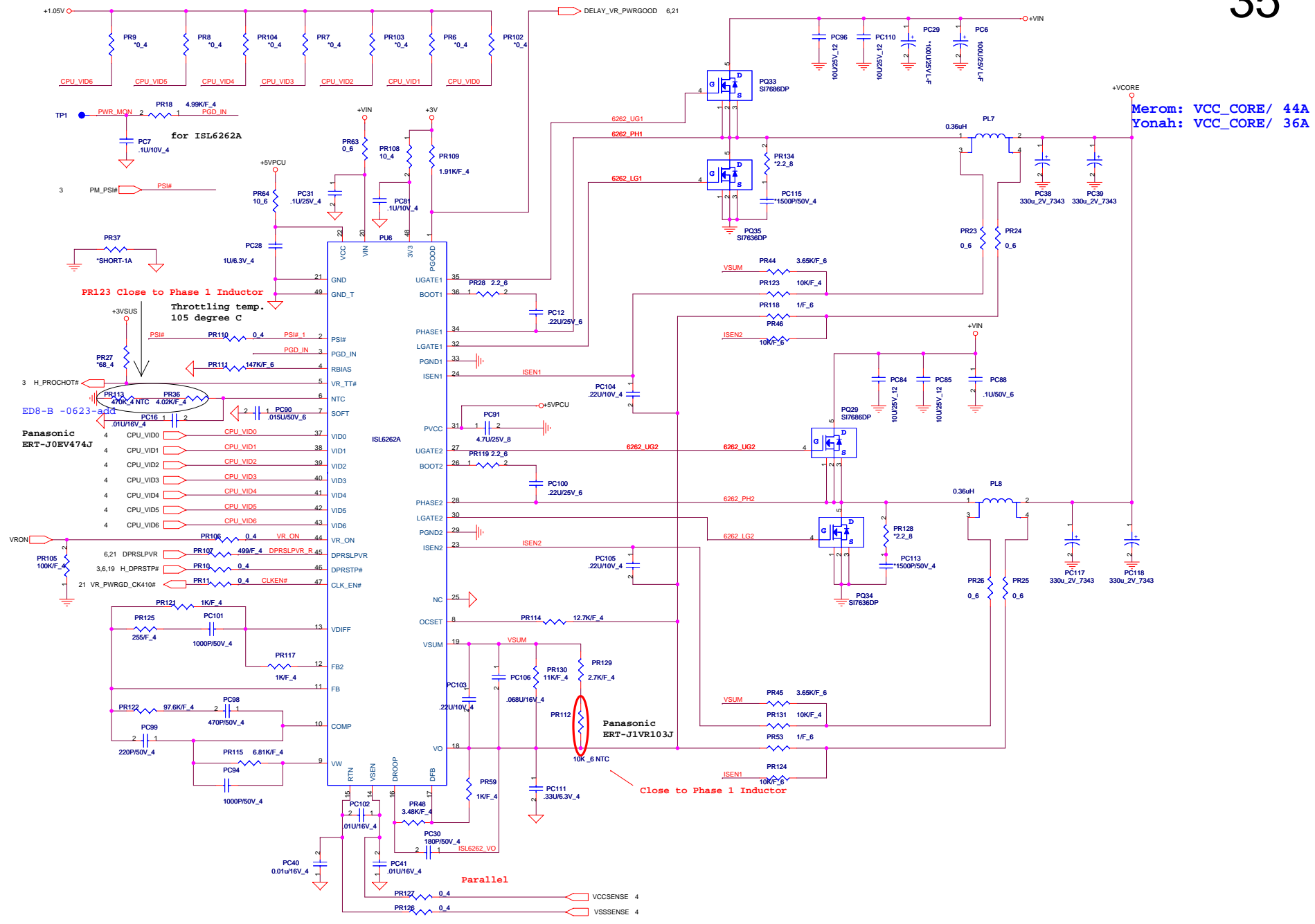

Merom: VCC_CORE/ 44A
 Yonah: VCC_CORE/ 36A

	PROJECT : QL6 Quanta Computer Inc.	
	Size: Custom Document Number: CPU Core (ISL6266A) Date: Tuesday, February 26, 2008	Rev: 2A Sheet: 35 of 40

VGA Core & VCC1.1

+1.1Volt +/- 5%
 Countinue current:15A
 Peak current:17A
 OCP minimum 22A

36

PC174
 0.22U --> 3ms
 1U --> 15ms

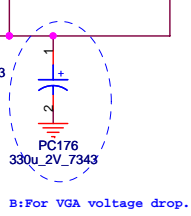
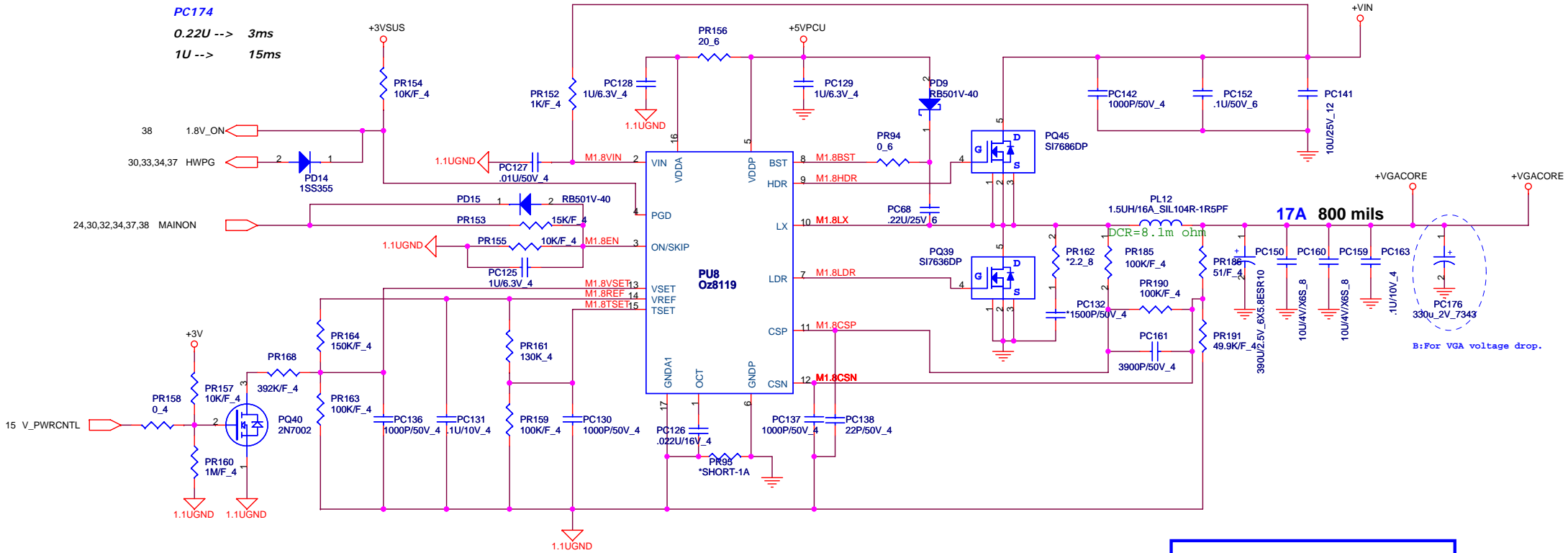

V_PWRCNTL	NVDIA NB9M	Resistor Value
HI	0.90V	PR67_392K_CS43922FB17
LO	1.09V	PR55_150K_CS41502FB18

V_PWRCNTL	nVDIA NB9P-GE2	Resistor Value
HI	1.15V	PR67_1.43M_CS51432FB10
LO	1.2V	PR55_130K_CS41302FB00

V_PWRCNTL	NVDIA NB9M-GE	Resistor Value
HI	0.95V	PR67_402K_CS44022FB25
LO	1.09V	PR55_150K_CS41502FB18

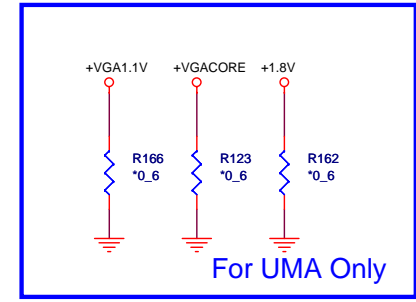

PROJECT : QL6
 Quanta Computer Inc.

Size B	Document Number VGA CORE OZ8118	Rev 2A
Date: Tuesday, February 26, 2008 Sheet 36 of 40		

1.8 Volt +/- 5%
 Countinue current:10A
 Peak current:12A
 OCP minimum 15A

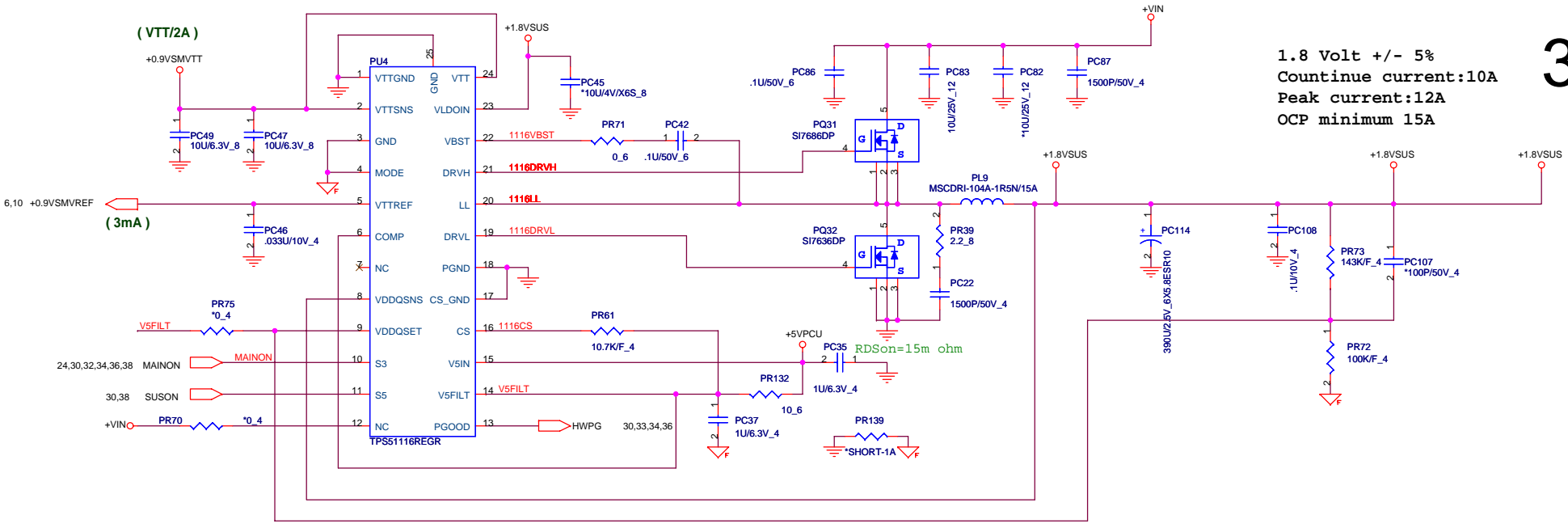

1.1 Volt +/- 5%
 Countinue current:2A
 Peak current:3A

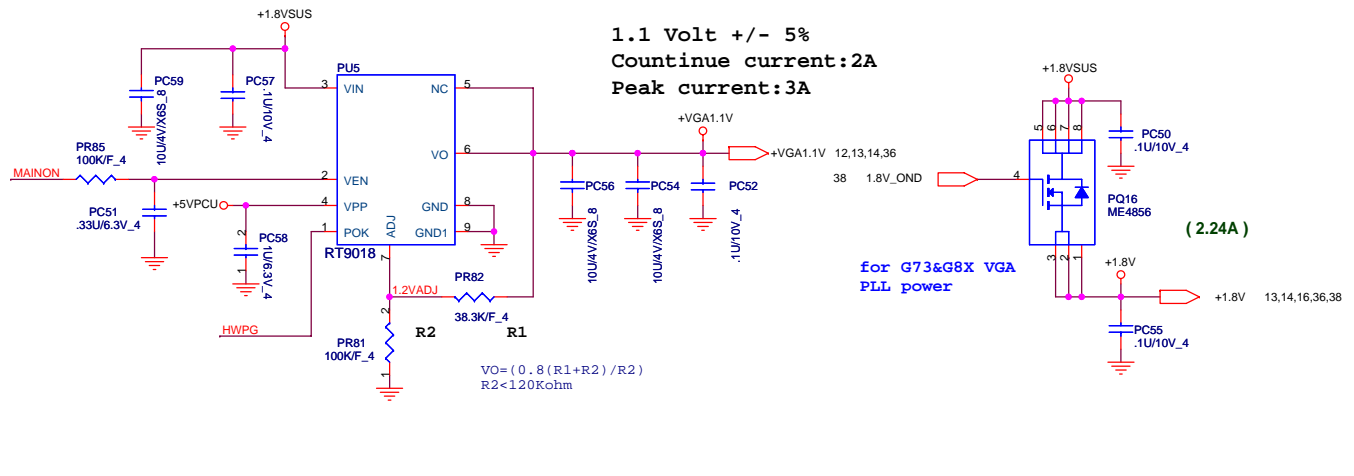

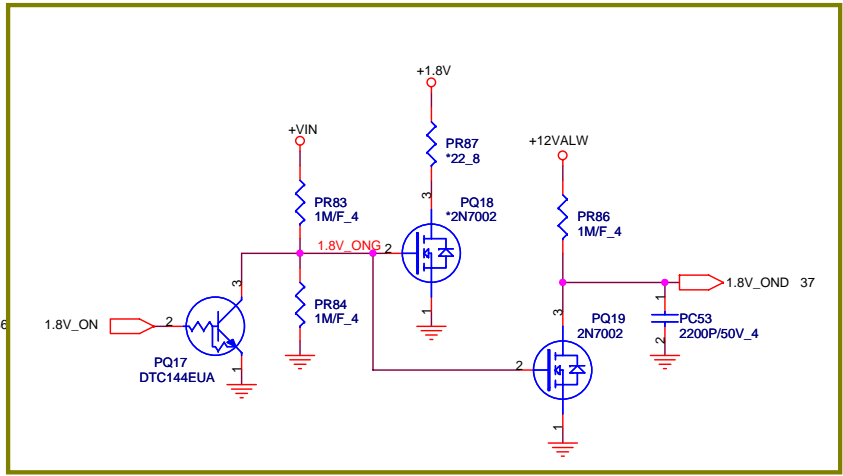
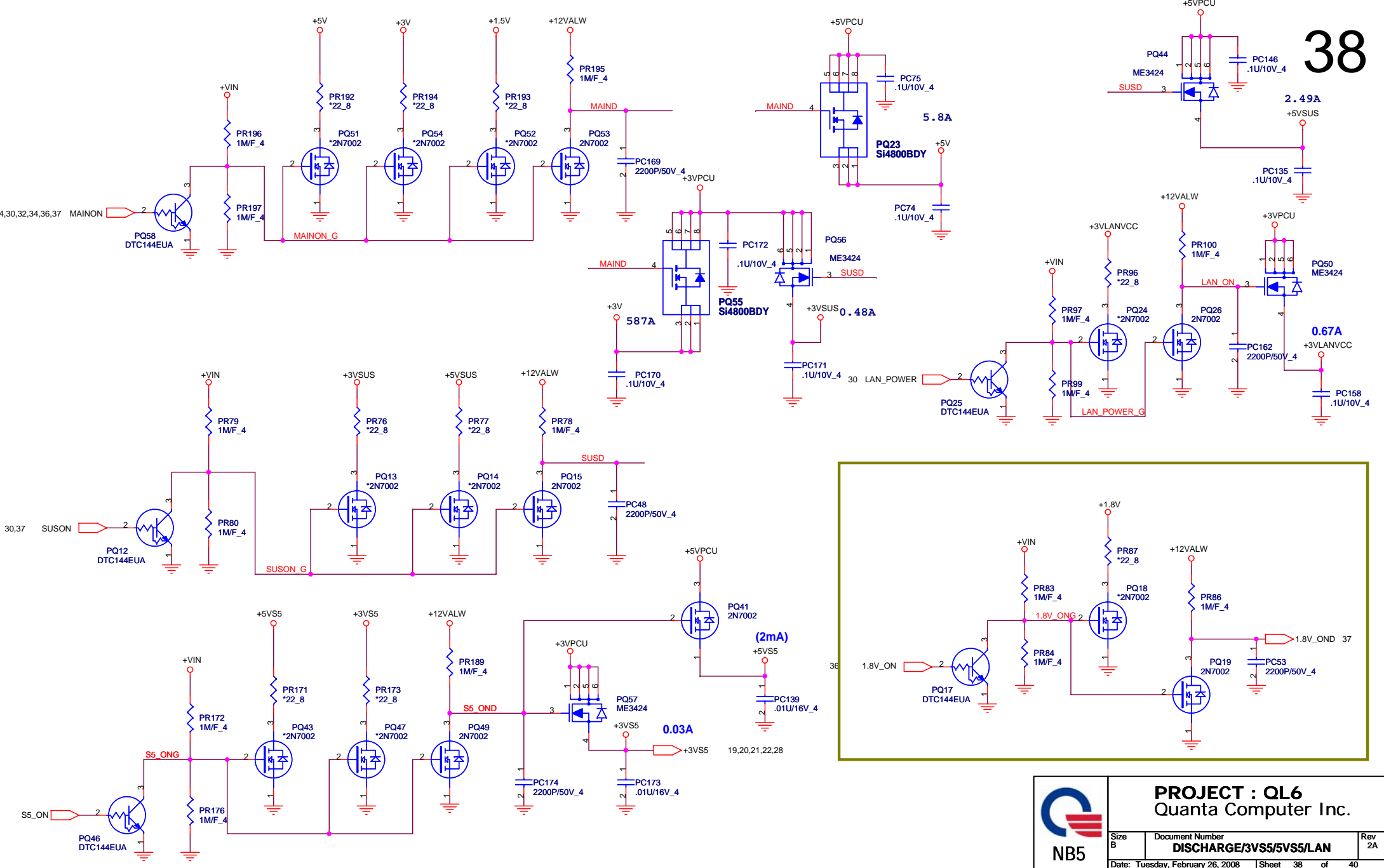

	Voltage level	AC MODE				DC MODE			
		S0	S3	S4	S5	S0	S3	S4	S5
+3VPCU	3.3V +/- 5%	V	V	V	V	V	V	V	V
+5VPCU	5V +/- 5%	V	V	V	V	V	V	V	V
+3VRTC	3.3V +/- 5%	V	V	V	V	V	V	V	V
+3VS5	3.3V +/- 5%	V	V	V	V	V	V		
+5VS5	5V +/- 5%	V	V	V	V	V	V		
+3VSUS	3.3V +/- 5%	V	V			V	V		
+5VSUS	5V +/- 5%	V	V			V	V		
+1.8VSUS	1.8V +/- 5%	V	V			V	V		
+0.9VSMVTT	0.9V +/- 5%	V	V			V	V		
+1.5V	1.5V +/- 5%	V				V			
+1.05V	1.05V +/- 5%	V				V			
+VCORE	0.9~1.15V	V				V			
+VGA_CORE	0.9~1.2V	V				V			
+VGA1.1V	1.1V +/- 5%	V				V			
+1.8V	1.8V +/- 5%	V				V			
+3VLAVCC	3.3V +/- 5%	V				V			