

JE1.1 Block Diagram

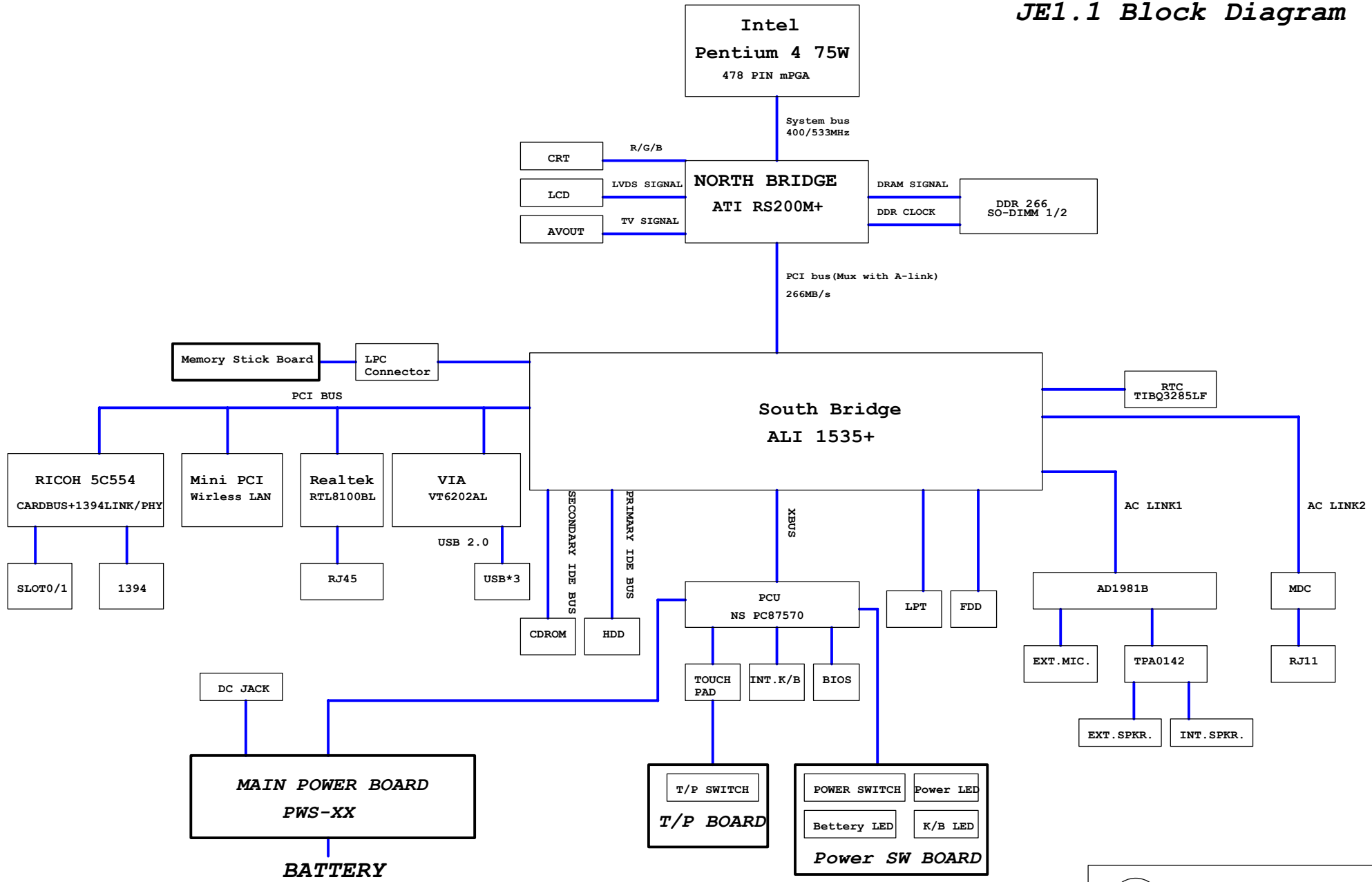

QUANTA COMPUTER

Size	Document Number	Rev
	JE1.1 Main Board	3A
Date:	星期二, 四月 06, 2003	Sheet 1 of 30

Page List

- 01 Block Diagram
 - 02 Page List
 - 03 Northwood CPU-1
 - 04 Northwood CPU-2
 - 05 RS200M-AGTL+
-
- 06 RS200M-DDR I/F
 - 07 RS200M-PCI & AGP I/F
 - 08 RS200M-VIDEO I/F & CLKGEN
 - 09 SYSTEM CONFIGURATION
 - 10 DDR Terminator
-
- 11 DDR SODIMMx2
 - 12 CRT PORT/TV
 - 13 ALI M1535+ (PCI,ISA) -1/2
 - 14 ALI M1535+ (USB,IDE,FDD) -2/2
 - 15 USB2.0 Controller (VT6202A)
-
- 16 Ricoh R5C554
 - 17 Cardbus slot
 - 18 LAN interface RTL8100B
 - 19 Mini PCI & MDC
 - 20 Audio CODEC
-
- 21 Audio AMP & Int. Speaker
 - 22 RTC/POWER GOOD LOGIC
 - 23 IDE/HDD/LPT Connector
 - 24 PCU NS 87570
 - 25 Int. Keyboard/Bios/FAN
-
- 26 HIP6301 (Vcc_core power)
 - 27 Max1632
 - 28 DDR / 1.8V Power
 - 29 Load Switch



Title		
COVER PAGE		
Size	Document Number	Rev
B	JE1.1 Main Board	1A
Date: 星期二, 四月 22, 2003	Sheet	2 of 30

(5) HA[3..31] >> HA[3..31]

HA3	K2	A#3
HA4	K4	A#4
HA5	L6	A#5
HA6	K10	A#6
HA7	M0	A#7
HA8	M6	A#8
HA9	L2	A#9
HA10	M3	A#10
HA11	M4	A#11
HA12	M0	A#11
HA13	N1	A#12
HA14	N2	A#13
HA15	N4	A#14
HA16	N5	A#16
HA17	T1	A#17
HA18	P4	A#18
HA19	P2	A#19
HA20	R3	A#20
HA21	R0	A#21
HA22	T2	A#22
HA23	U1	A#23
HA24	P6	A#24
HA25	B0	A#24
HA26	T4	A#25
HA27	V2	A#26
HA28	R6	A#28
HA29	W1	A#29
HA30	T8	A#30
HA31	U4	A#31

(5) HD[0..63] >> HD[0..63]

HD0	B21	D#0
HD1	B22	D#1
HD2	A23	D#2
HD3	A25	D#3
HD4	C21	D#4
HD5	D22	D#5
HD6	B24	D#5
HD7	C23	D#6
HD8	C24	D#8
HD9	B25	D#9
HD10	G22	D#10
HD11	H21	D#11
HD12	C26	D#11
HD13	D23	D#13
HD14	J21	D#14
HD15	D25	D#15
HD16	H22	D#16
HD17	E24	D#17
HD18	G23	D#18
HD19	F23	D#19
HD20	F24	D#20
HD21	E25	D#21
HD22	D26	D#22
HD23	D28	D#23
HD24	L21	D#23
HD25	G26	D#25
HD26	H24	D#26
HD27	M21	D#27
HD28	L22	D#28
HD29	K24	D#29
HD30	K23	D#29
HD31	H25	D#30
HD32	M23	D#32
HD33	N22	D#33
HD34	P21	D#34
HD35	M24	D#34
HD36	N23	D#35
HD37	M26	D#36
HD38	N26	D#38
HD39	N25	D#39
HD40	R21	D#40
HD41	P24	D#41
HD42	R25	D#41
HD43	R24	D#42
HD44	T26	D#44
HD45	T25	D#45
HD46	T22	D#46
HD47	T23	D#46
HD48	U26	D#47
HD49	U24	D#48
HD50	U23	D#50
HD51	V25	D#51
HD52	V22	D#52
HD53	V24	D#53
HD54	V24	D#53
HD55	W26	D#54
HD56	Y26	D#55
HD57	W25	D#57
HD58	Y23	D#58
HD59	Y24	D#58
HD60	Y21	D#59
HD61	AA25	D#60
HD62	AA22	D#62
HD63	AA24	D#63

(5) -HDB[0..3] >> -HDB[0..3]

A20M	C6	-HA20M	A#3
FERR	B6	-HFERR	A#4
INIT	W5	-HCPUINIT	A#5
LINT0	D1	-INTR	A#6
LINT1	E5	-INTR	A#7
IGNNE	B2	-IGNNE	A#8
SMI	R5	-SMI	A#9
SLP	AB26	-SLP	A#10
STPCLK	Y4	-STPCLK	A#11
ADS	G1	-HADS	A#12
ADSTB0	L5	-HA_STB0	A#13
ADSTB1	R5	-HA_STB1	A#14
ADSTB2	G2	-HBNR	A#15
BNR	H5	-HDBSY	A#16
DBSY	E2	-HDEFER	A#17
DEFER	H2	-HDRDY	A#18
DRDY	E3	-HHIT	A#19
DRDY	E3	-HHITM	A#20
DRDY	J6	-HTRDY	A#21
DRDY	D2	-HBPRI	A#22
DRDY	H6	-HBREQ0	A#23
DRDY	G4	-HLOCK	A#24
REQ0	H1	-HREQ0	A#25
REQ1	K5	-HREQ1	A#26
REQ2	H4	-HREQ2	A#27
REQ3	H3	-HREQ3	A#28
REQ4	H3	-HREQ4	A#29
RS0	F1	-HRS0	A#30
RS1	G5	-HRS1	A#31
RS2	F4	-HRS2	A#32

A20M	C6	-HA20M	A#3
FERR	B6	-HFERR	A#4
INIT	W5	-HCPUINIT	A#5
LINT0	D1	-INTR	A#6
LINT1	E5	-INTR	A#7
IGNNE	B2	-IGNNE	A#8
SMI	R5	-SMI	A#9
SLP	AB26	-SLP	A#10
STPCLK	Y4	-STPCLK	A#11
ADS	G1	-HADS	A#12
ADSTB0	L5	-HA_STB0	A#13
ADSTB1	R5	-HA_STB1	A#14
ADSTB2	G2	-HBNR	A#15
BNR	H5	-HDBSY	A#16
DBSY	E2	-HDEFER	A#17
DEFER	H2	-HDRDY	A#18
DRDY	E3	-HHIT	A#19
DRDY	E3	-HHITM	A#20
DRDY	J6	-HTRDY	A#21
DRDY	D2	-HBPRI	A#22
DRDY	H6	-HBREQ0	A#23
DRDY	G4	-HLOCK	A#24
REQ0	H1	-HREQ0	A#25
REQ1	K5	-HREQ1	A#26
REQ2	H4	-HREQ2	A#27
REQ3	H3	-HREQ3	A#28
REQ4	H3	-HREQ4	A#29
RS0	F1	-HRS0	A#30
RS1	G5	-HRS1	A#31
RS2	F4	-HRS2	A#32

DSTBP0	F21	-HD_STBP0	D#0
DSTBN0	E22	-HD_STBN0	D#1
DSTBP1	J23	-HD_STBP1	D#2
DSTBN1	K22	-HD_STBN1	D#3
DSTBP2	R23	-HD_STBP2	D#4
DSTBN2	R22	-HD_STBN2	D#5
DSTBP3	W23	-HD_STBP3	D#6
DSTBN3	W22	-HD_STBN3	D#7
BCLK0	AE22	CPUCLK+	D#10
BCLK1	AE23	CPUCLK-	D#11
ITP_CLK1	AD26	ITP_CLK+	D#15
ITP_CLK0	AC26	ITP_CLK-	D#15
IERR	AC3	-IERR	D#17
MCERR	V6	-MCERR	D#19
DBRESET	AE25	DBRESET	D#20
RESET	AB25	-CPURST	D#22
PWRGOOD	AB23	PWRGD_CPU	D#24
SKTOCC	AE26	T108	D#27
COMP0	L24	CPU_COMP0	D#29
COMP1	P1	CPU_COMP1	D#29
DEP0	J26	T117	D#32
DEP1	K25	T119	D#33
DEP2	K26	T121	D#34
DEP3	L25	T123	D#35
THERMDA	B3	THERMDA	D#37
THERMDC	C4	THERMDC	D#38
THERMTRIP	A2	-TRIP	D#39
PROCOT	C3	-PROCOT	D#40
TESTH10	AD24	HTEST0	D#41
TESTH11	AA2	HTEST1	D#42
TESTH12	AC21	HTEST2	D#44
TESTH13	AC20	HTEST3	D#45
TESTH14	AC24	HTEST4	D#46
TESTH15	AC23	HTEST5	D#46
TESTH16	AA20	ITPCLK0	D#47
TESTH17	AB22	ITPCLK1	D#49
TESTH18	U6	HTEST8	D#48
TESTH19	W4	HTEST9	D#49
TESTH10	Y3	HTEST10	D#50
TESTH11	A6	-GHI	D#51
TESTH12	AD25	-DPSLP	D#53
BSEL0	AD6	BS0	D#55
BSEL1	AD5	BS1	D#57
TCK	D4	TCK	D#59
TDI	C1	TDI	D#60
TD0	D5	TD0	D#61
TMS	E7	TMS	D#62
TRST	E6	-TRST	D#63

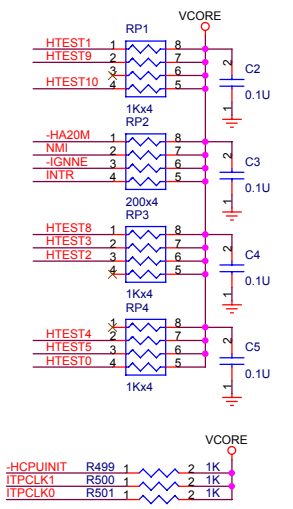
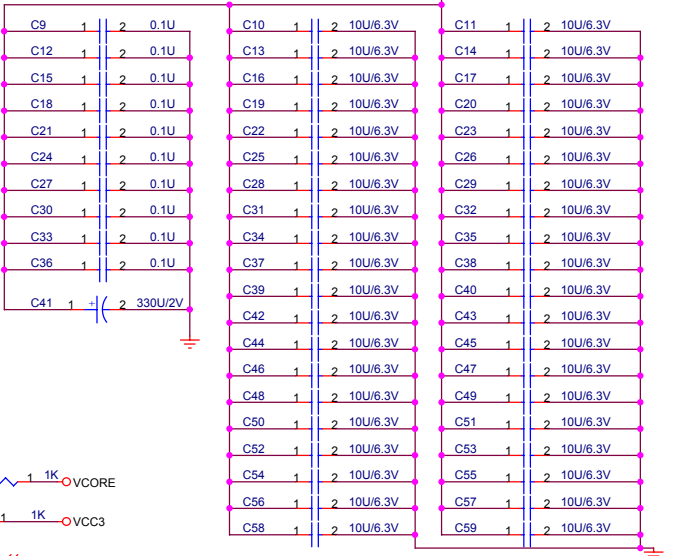
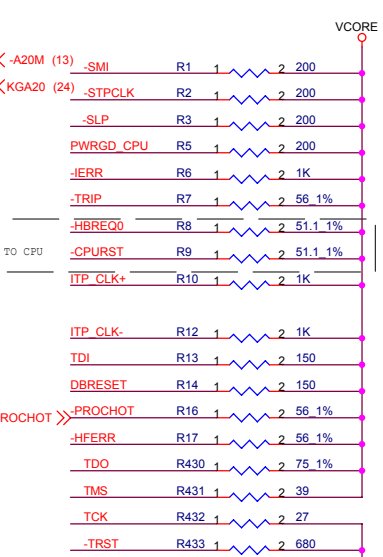
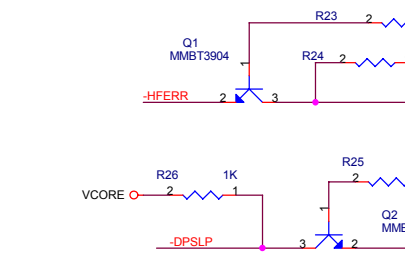
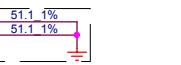
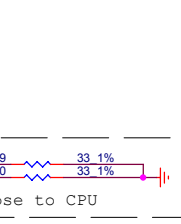
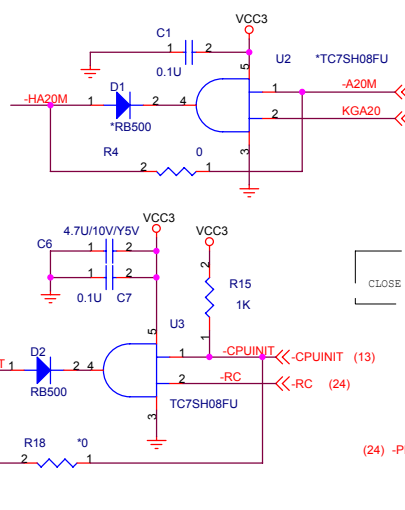

QUANTA COMPUTER

File: **CPU Socket -1/2- Signal**

Size B Document Number **JE1.1 Main Board** Rev 3A

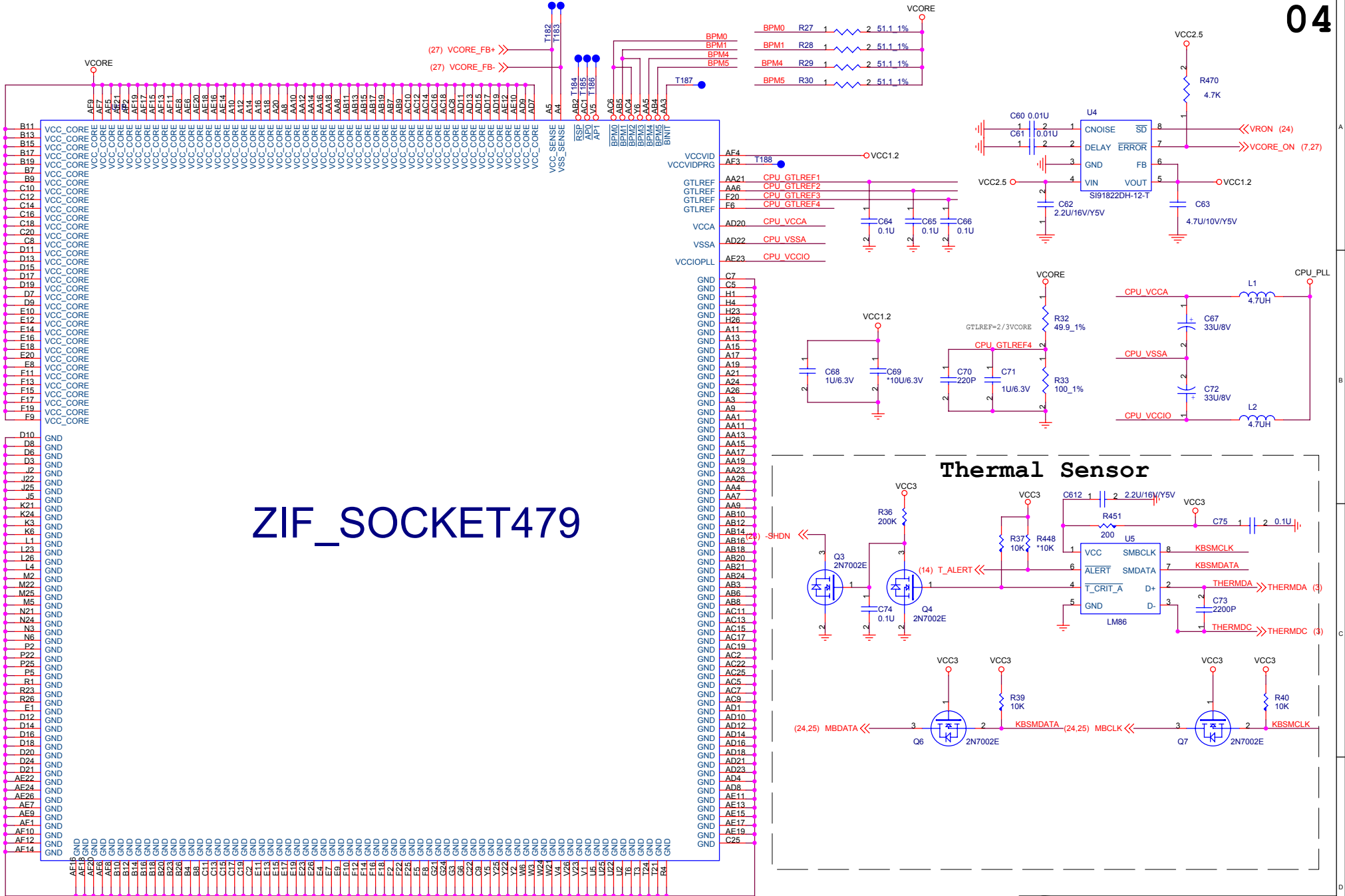

Thermal Sensor

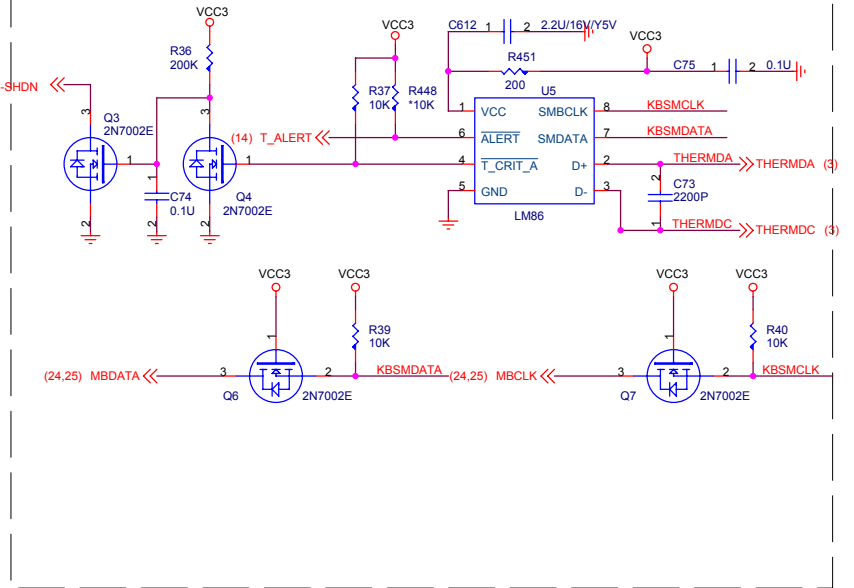

QUANTA COMPUTER

Title: **CPU Socket -2/2- Power & Ground**

Size B Document Number **JE1.1 Main Board** Rev 1A

ATI_RS200M+ - 2 (DDR Interface)

MDI0_63I >>> MD[0..63] (10,11)
 MDQM0_7I >>> MDQM[0..7] (10,11)
 MDQS0_7I >>> MDQS[0..7] (10,11)

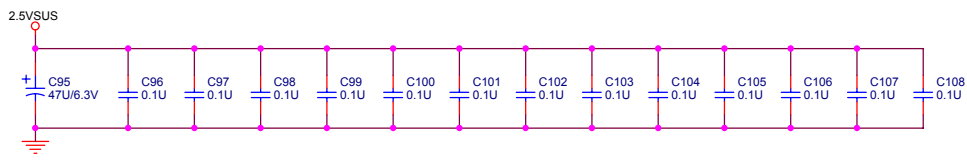
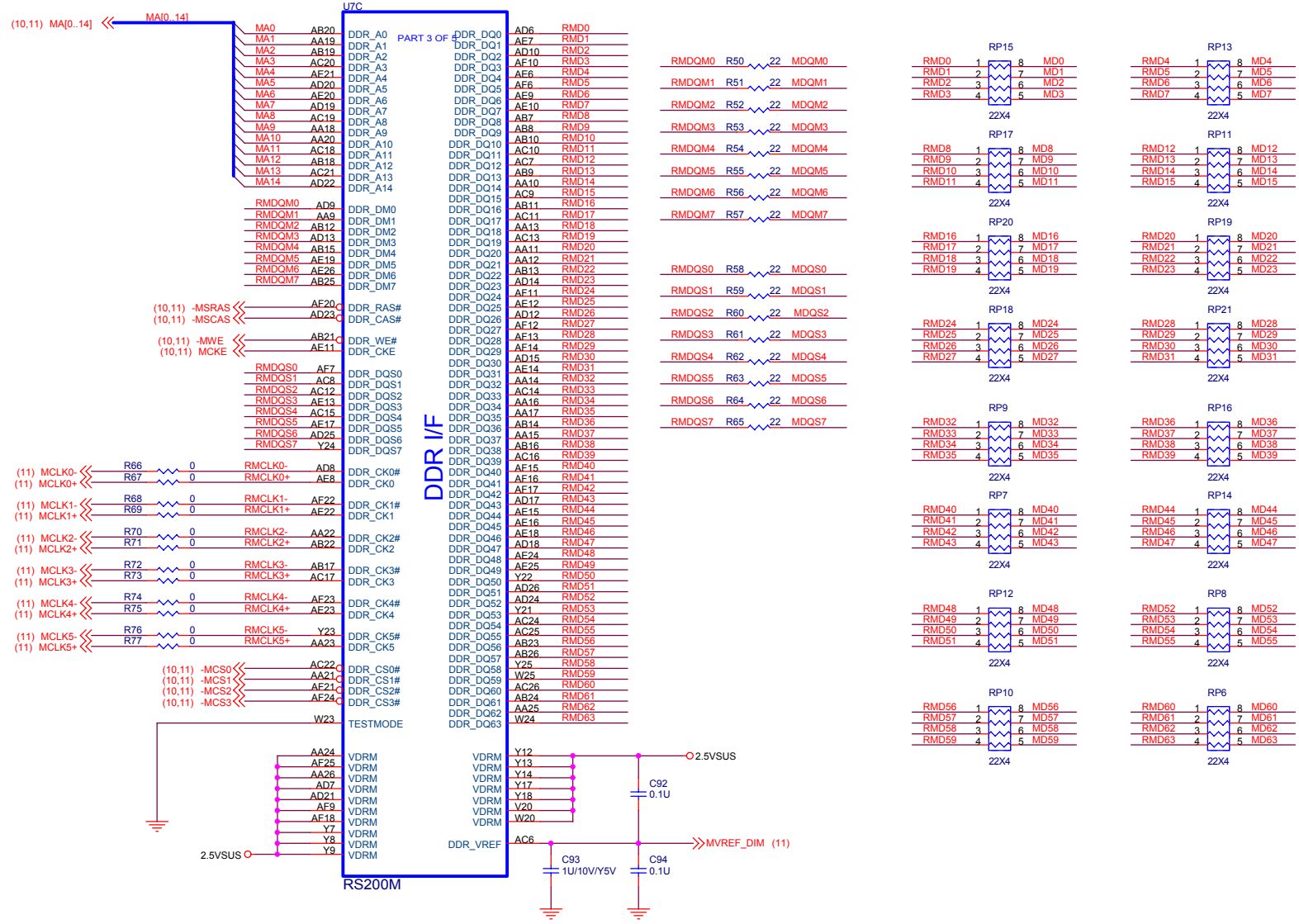

QUANTA COMPUTER

Title: **RS200M 2/4**

Size B Document Number **JE1.1 Main Board** Rev 1A

THIS PART SHOULD NOT CONTAIN ANY SUBSTANCES WHICH ARE SPECIFIED IN SS-00259-1. Date: 星期二, 四月 22, 2003 Sheet 6 of 30

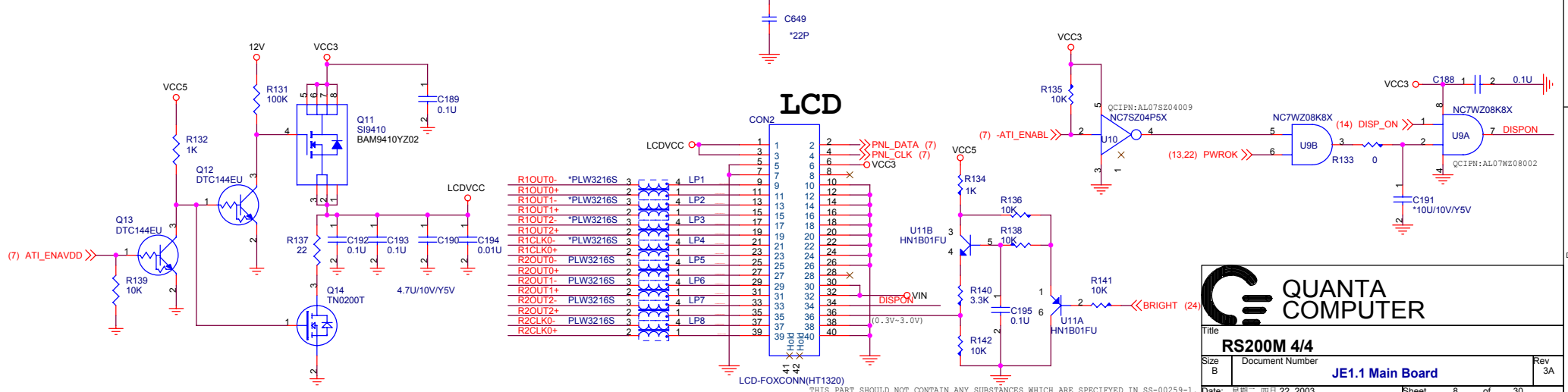
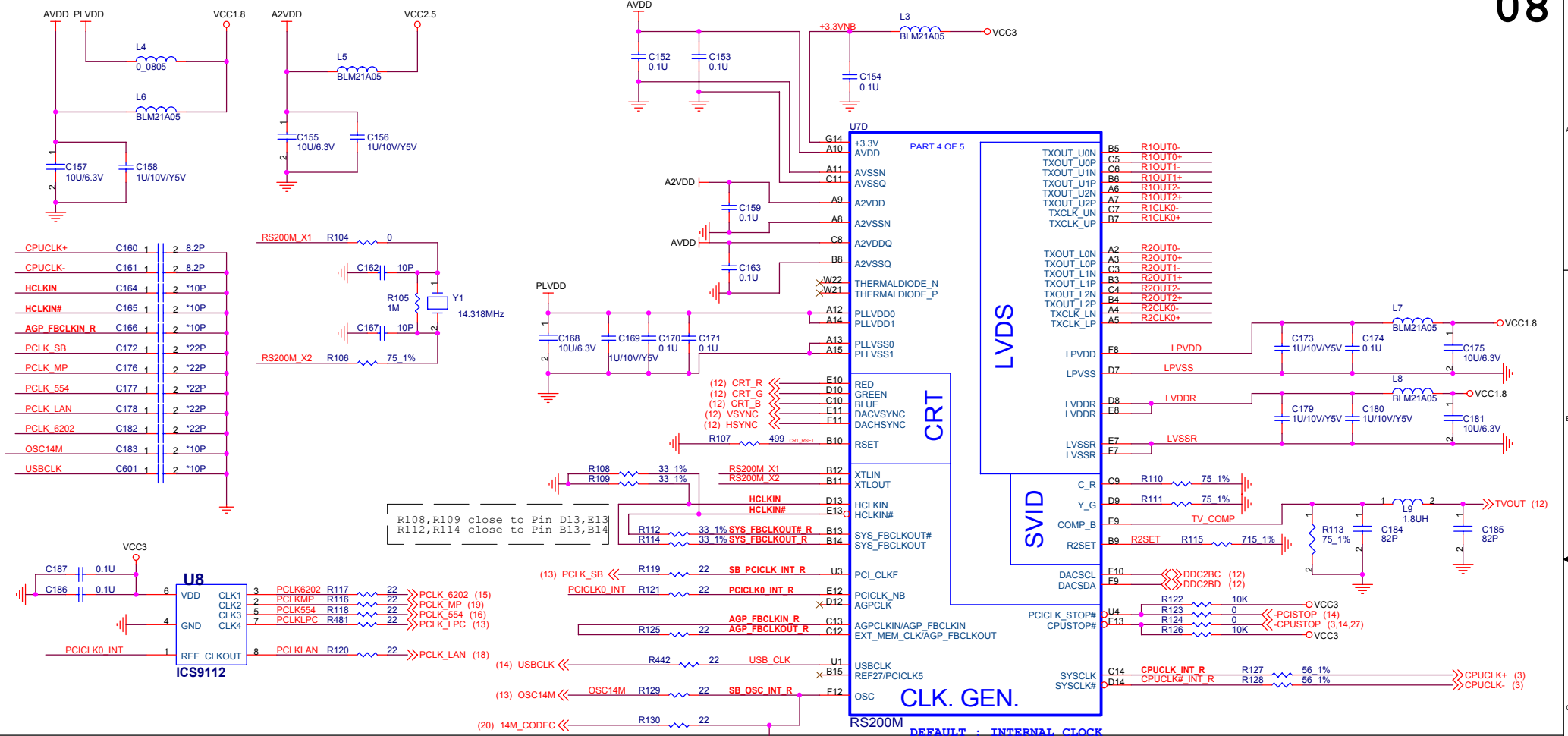

QUANTA COMPUTER

RS200M 4/4

Size B Document Number **JE1.1 Main Board** Rev 3A

Date: 星期二, 四月 22, 2003 Sheet 8 of 30

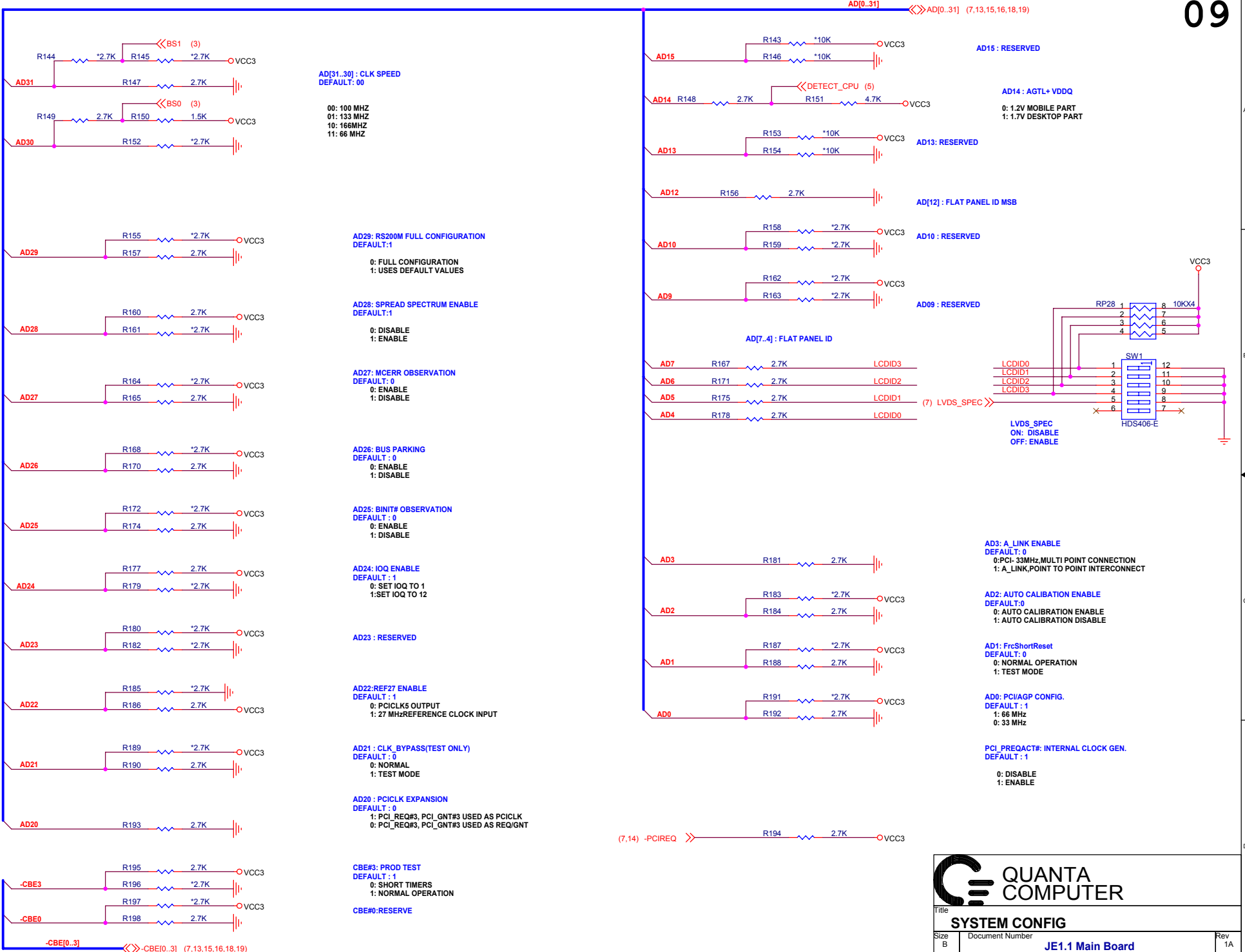

AD[31..30] : CLK SPEED
 DEFAULT: 00

00: 100 MHZ
 01: 133 MHZ
 10: 166MHZ
 11: 66 MHZ

AD29: RS200M FULL CONFIGURATION
 DEFAULT:1

0: FULL CONFIGURATION
 1: USES DEFAULT VALUES

AD28: SPREAD SPECTRUM ENABLE
 DEFAULT:1

0: DISABLE
 1: ENABLE

AD27: MCERR OBSERVATION
 DEFAULT: 0

0: ENABLE
 1: DISABLE

AD26: BUS PARKING
 DEFAULT : 0

0: ENABLE
 1: DISABLE

AD25: BINIT# OBSERVATION
 DEFAULT : 0

0: ENABLE
 1: DISABLE

AD24: IOQ ENABLE
 DEFAULT : 1

0: SET IOQ TO 1
 1:SET IOQ TO 12

AD23 : RESERVED

AD22:REF27 ENABLE
 DEFAULT : 1

0: PCICLK5 OUTPUT
 1: 27 MHzREFERENCE CLOCK INPUT

AD21 : CLK_BYPASS(TEST ONLY)
 DEFAULT : 0

0: NORMAL
 1: TEST MODE

AD20 : PCICLK EXPANSION
 DEFAULT : 0

1: PCI_REQ#3, PCI_GNT#3 USED AS PCICLK
 0: PCI_REQ#3, PCI_GNT#3 USED AS REQ/GNT

CBE#3: PROD TEST
 DEFAULT : 1

0: SHORT TIMERS
 1: NORMAL OPERATION

CBE#0:RESERVE

AD[0..31] <<>>AD[0..31] (7,13,15,16,18,19)

AD15 : RESERVED

AD14 : AGTL+ VDDQ
 0: 1.2V MOBILE PART
 1: 1.7V DESKTOP PART

AD13: RESERVED

AD12] : FLAT PANEL ID MSB

AD10 : RESERVED

AD09 : RESERVED

AD[7..4] : FLAT PANEL ID

AD7 R167 2.7K LCDID3
AD6 R171 2.7K LCDID2
AD5 R175 2.7K LCDID1
AD4 R178 2.7K LCDID0 (7) LVDS_SPEC <>>

AD3 R181 2.7K

AD2 R183 *2.7K VCC3
 R184 2.7K

AD1 R187 *2.7K VCC3
 R188 2.7K

AD0 R191 *2.7K VCC3
 R192 2.7K

(7,14) -PCIREQ <>> R194 2.7K VCC3

AD3: A_LINK ENABLE
 DEFAULT: 0
 0:PCI- 33MHz,MULTI POINT CONNECTION
 1: A_LINK,POINT TO POINT INTERCONNECT

AD2: AUTO CALIBRATION ENABLE
 DEFAULT:0
 0: AUTO CALIBRATION ENABLE
 1: AUTO CALIBRATION DISABLE

AD1: FrcShortReset
 DEFAULT: 0
 0: NORMAL OPERATION
 1: TEST MODE

AD0: PCI/AGP CONFIG.
 DEFAULT : 1
 1: 66 MHz
 0: 33 MHz

PCI_PREQACT#: INTERNAL CLOCK GEN.
 DEFAULT : 1

0: DISABLE
 1: ENABLE

QUANTA COMPUTER

Title: **SYSTEM CONFIG**

Size B Document Number **JE1.1 Main Board** Rev 1A

Date: 星期二, 四月 22, 2003 Sheet 9 of 30

DDR TERMINATOR MD Terminator

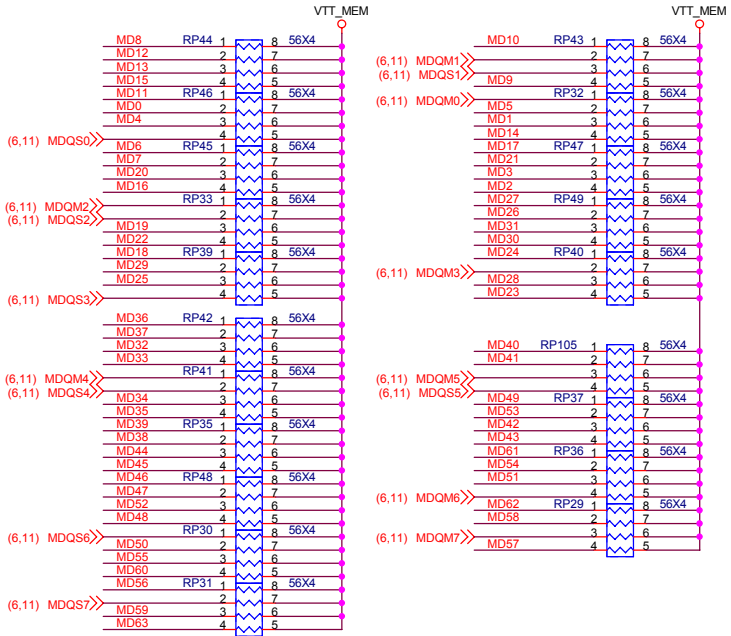

(6,11) MD[0..63] >> MD[0..63]
 (6,11) MA[0..14] >> MA[0..14]

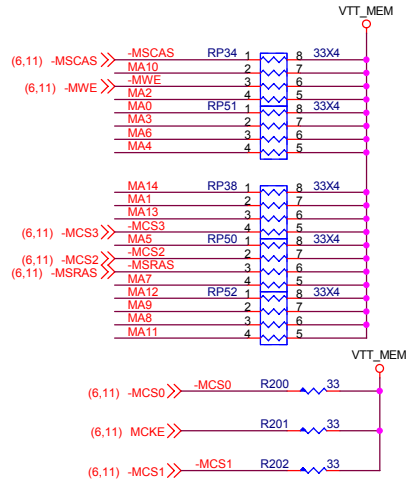

MA Terminator

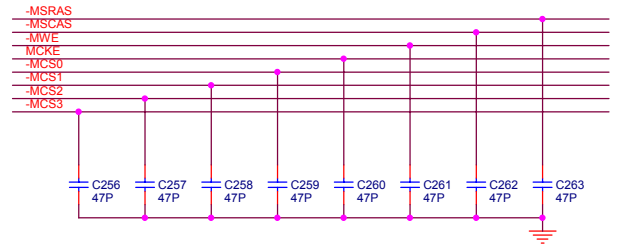
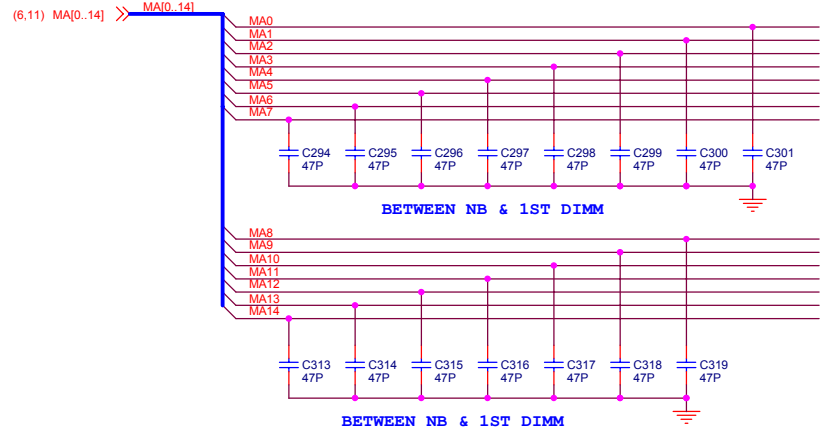

DQM Terminator 10

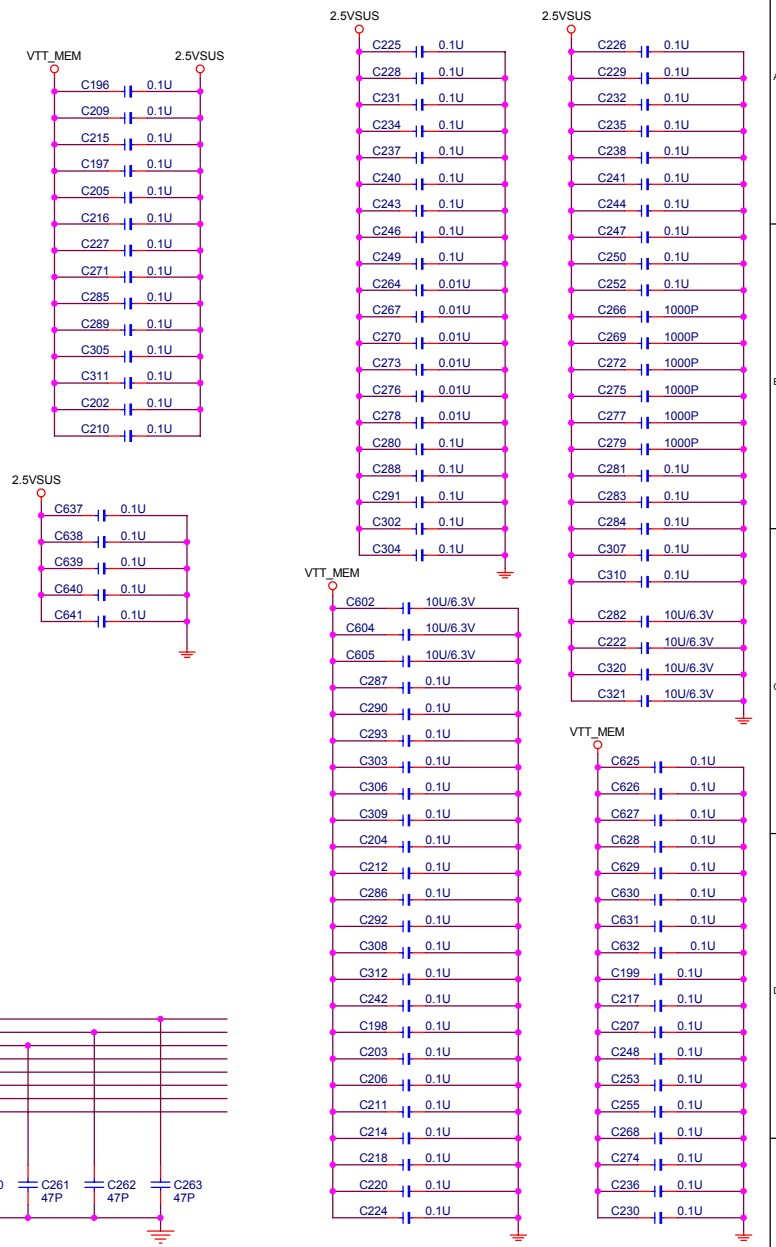

Title		Memory -1/2- Terminator	
Size	B	Document Number	JE1.1 Main Board
Date: 2003.04.22		Sheet	10 of 30

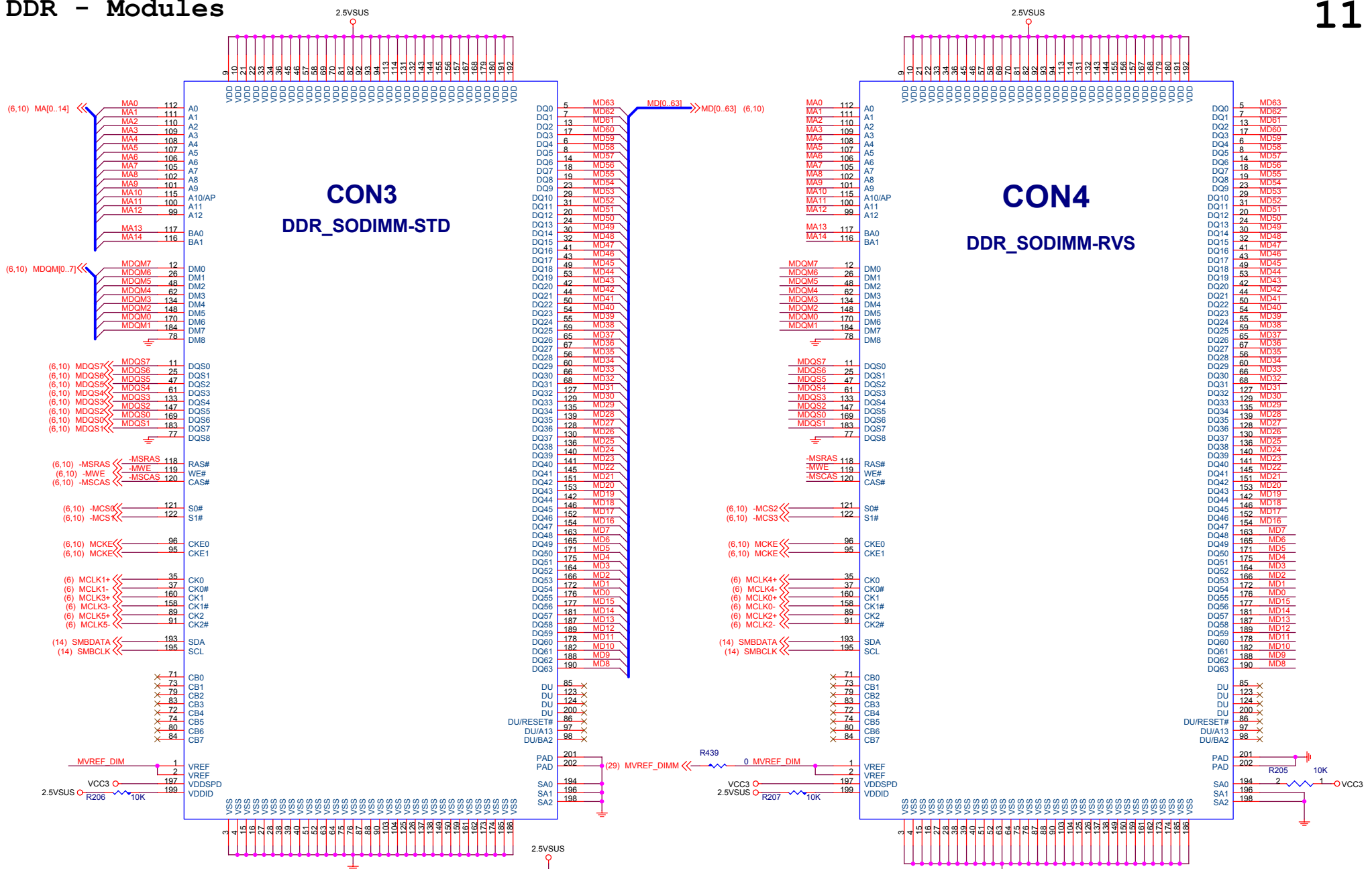

QUANTA COMPUTER

Title: **Memory -2/2- SODIMM**

Size B Document Number **JE1.1 Main Board** Rev 4A

Date: 星期二, 四月 22, 2003 Sheet 11 of 30

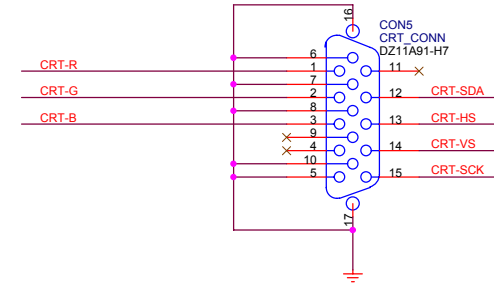
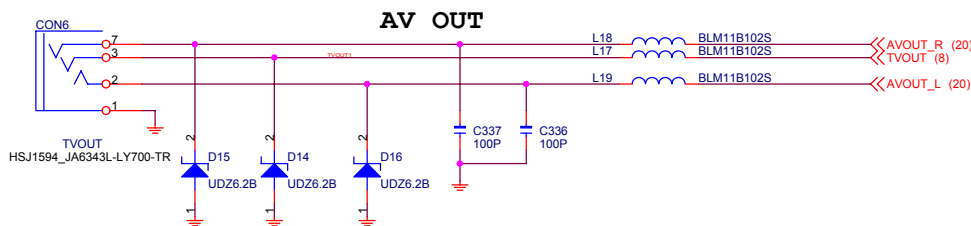
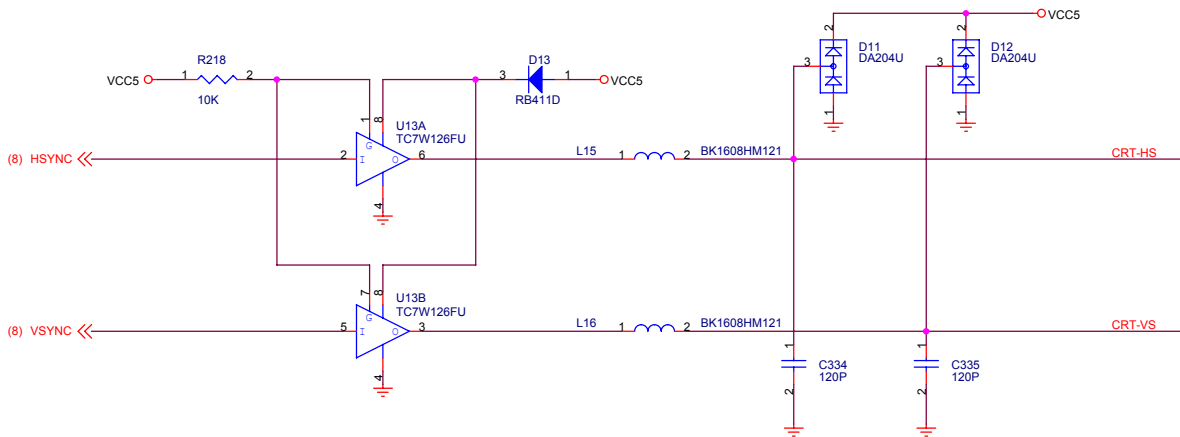
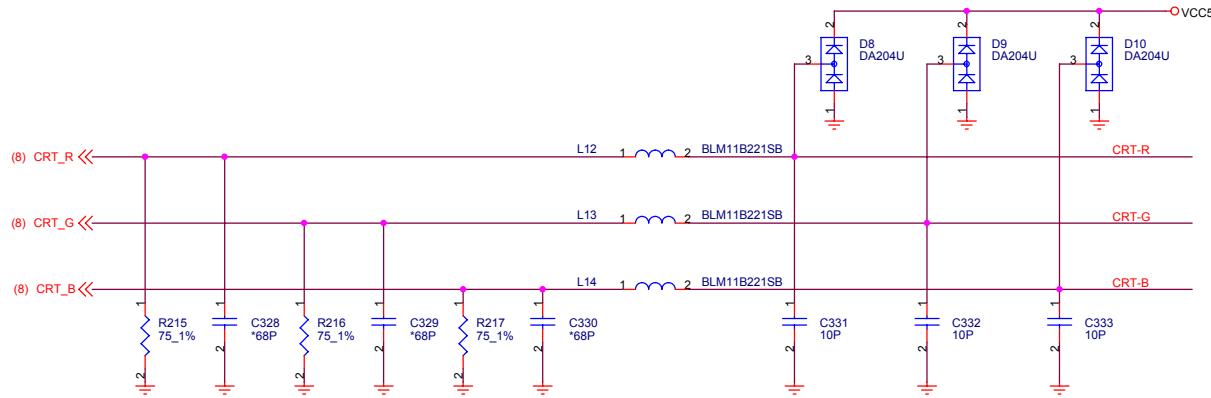
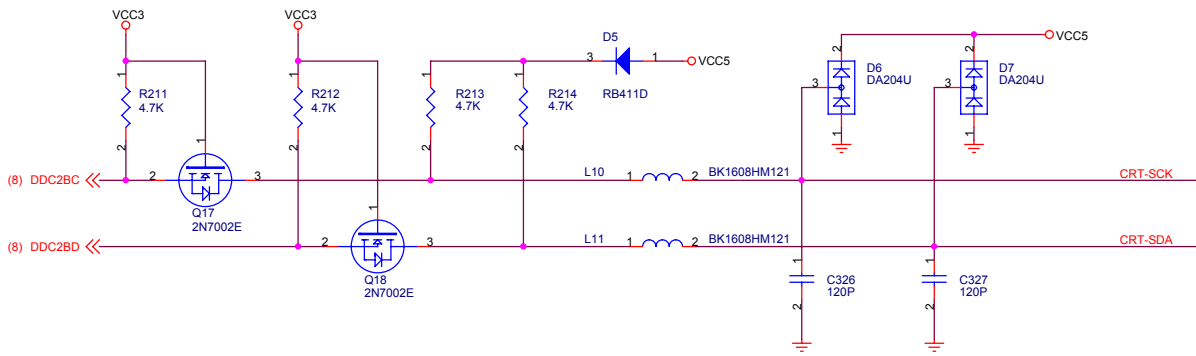

Title		CRT PORT/TV	
Size	Document Number	JE1.1 Main Board	
B		Rev	2A

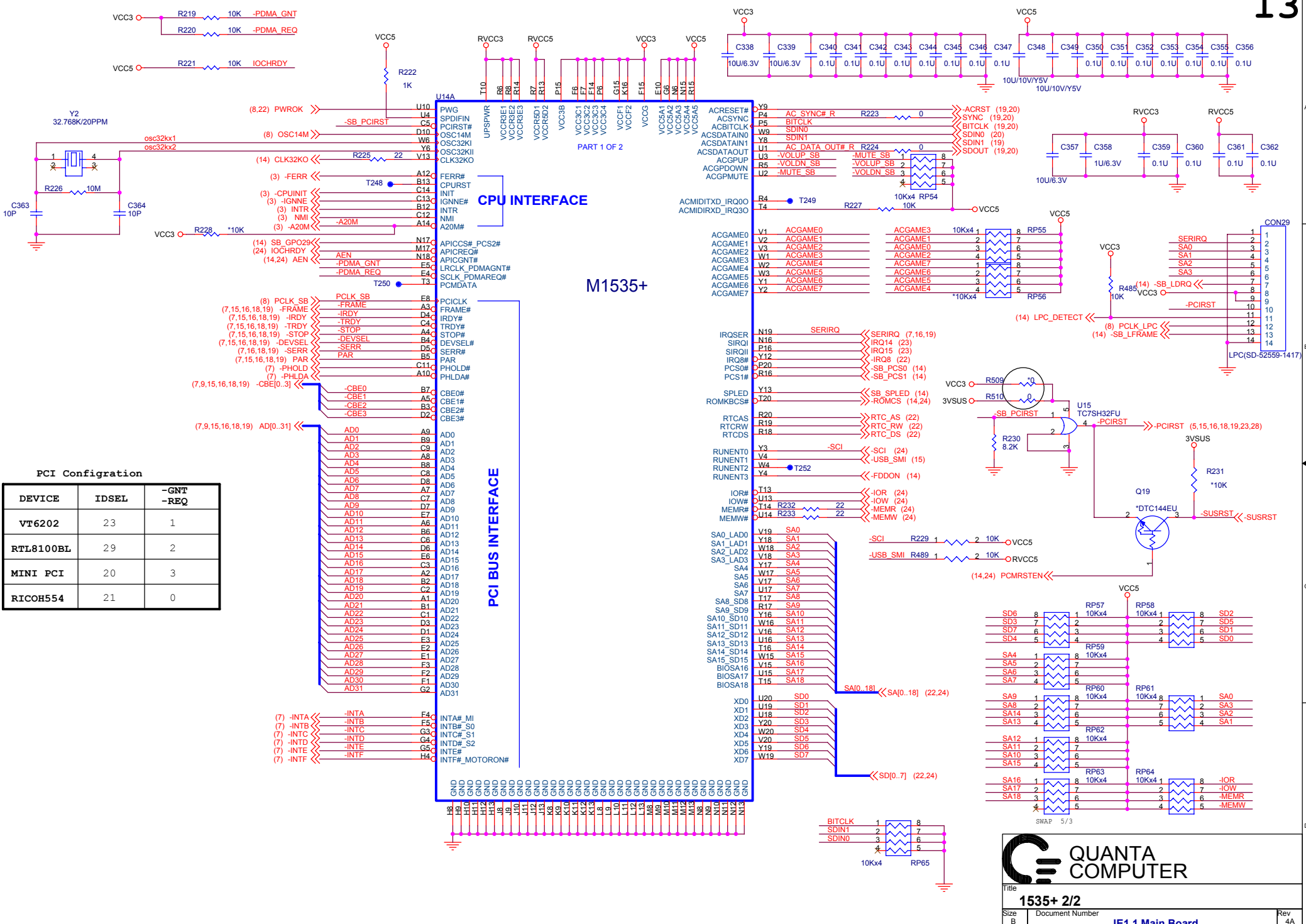

PCI Configuration

DEVICE	IDSEL	-GNT -REQ
VT6202	23	1
RTL8100BL	29	2
MINI PCI	20	3
RICOH554	21	0

QUANTA COMPUTER

Title: **1535+ 2/2**

Size B Document Number **JE1.1 Main Board** Rev 4A

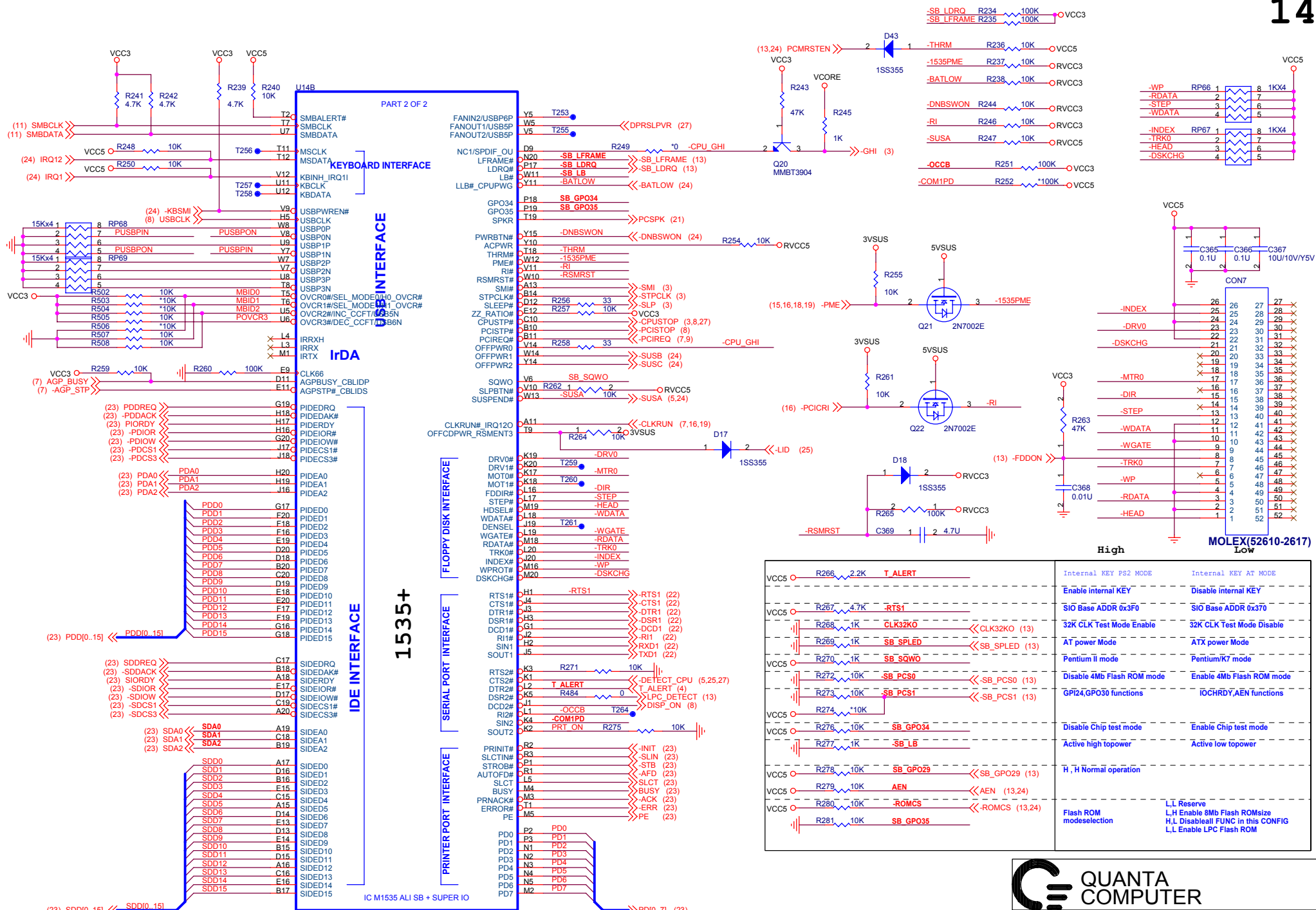

High
Low
MOLEX(52610-2617)

	Internal KEY PS2 MODE	Internal KEY AT MODE
VCC5 - R266 2.2K T_ALERT	Enable internal KEY	Disable internal KEY
VCC5 - R267 4.7K -RTS1	SiO Base ADDR 0x3F0	SiO Base ADDR 0x370
R268 1K CLK32K0 << CLK32KO (13)	32K CLK Test Mode Enable	32K CLK Test Mode Disable
R269 1K SB_SPLED << SB_SPLED (13)	AT power Mode	ATX power Mode
VCC5 - R270 1K SB_SQWO	Pentium II mode	Pentium/K7 mode
R272 10K SB_PCS0 << SB_PCS0 (13)	Disable 4Mb Flash ROM mode	Enable 4Mb Flash ROM mode
R273 10K SB_PCS1 << SB_PCS1 (13)	GP124,GPO30 functions	IOCHRDY_AEN functions
VCC5 - R274 10K	Disable Chip test mode	Enable Chip test mode
R276 10K SB_GPO34	Active high topower	Active low topower
R277 1K SB_LB	H, H Normal operation	
VCC5 - R278 10K SB_GPO29 << SB_GPO29 (13)	Flash ROM modeselection	
VCC5 - R279 10K AEN << AEN (13,24)	L.L Reserve	L.L Reserve
R280 10K -ROMCS << -ROMCS (13,24)	L.H Enable 8Mb Flash ROMsize	L.H Disable! FUNC in this CONFIG
R281 10K SB_GPO35	L.L Enable LPC Flash ROM	



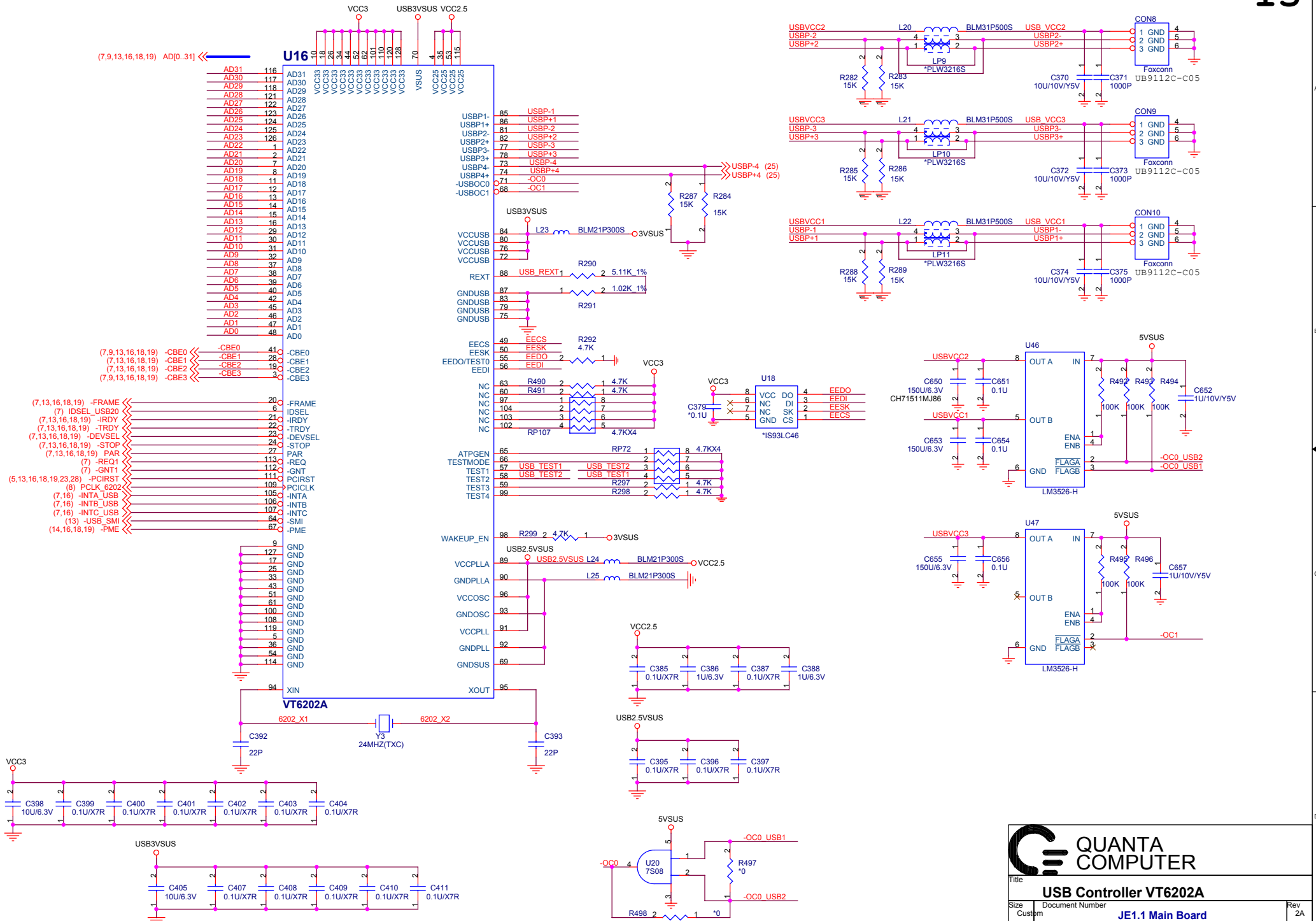

		QUANTA COMPUTER	
		Title: USB Controller VT6202A	
Size: Custom	Document Number: JE1.1 Main Board	Rev: 2A	
Date: 星期二, 四月 22, 2003		Sheet: 15	of 30

THIS PART SHOULD NOT CONTAIN ANY SUBSTANCES WHICH ARE SPECIFIED IN SS-00259-1.

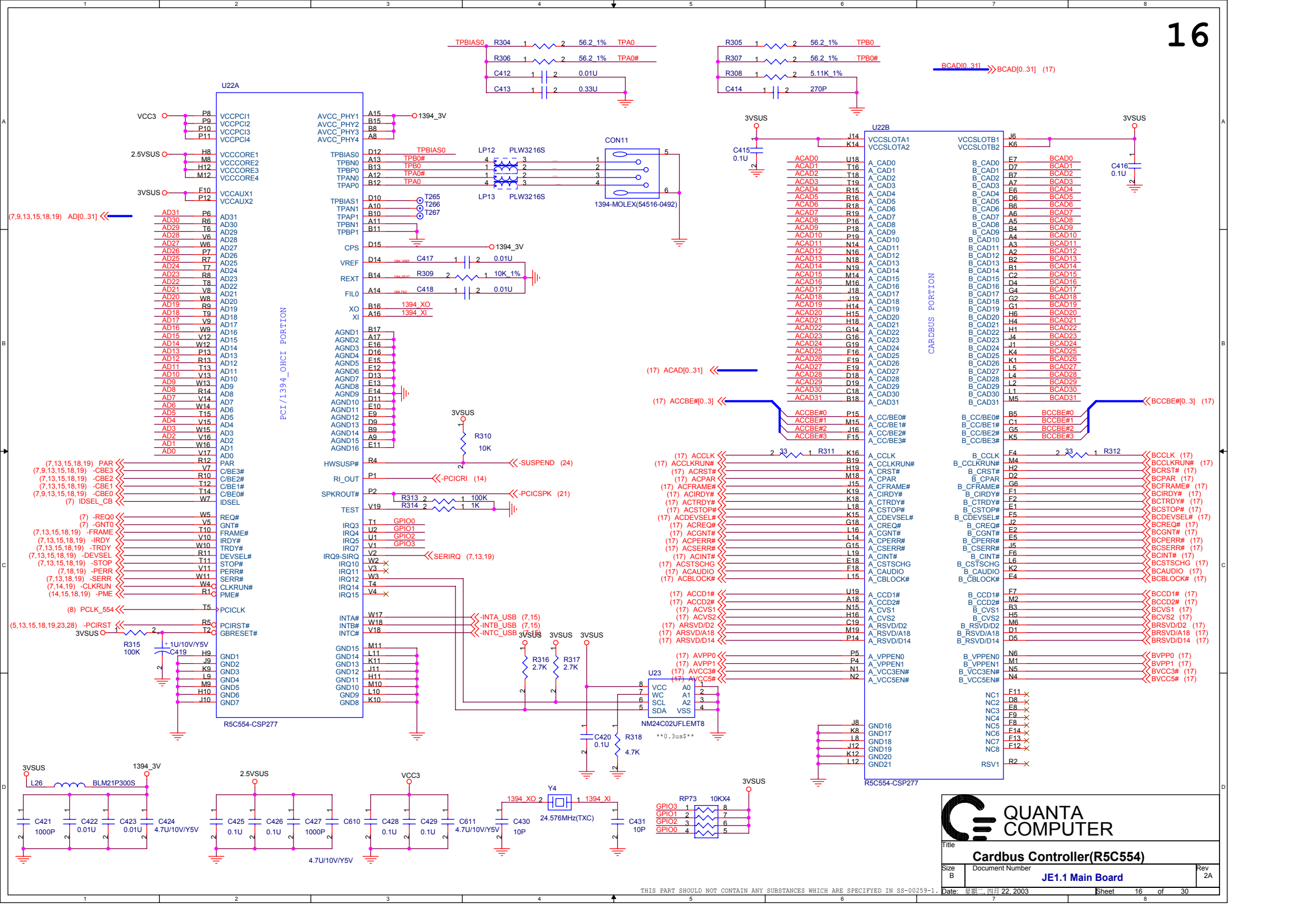

QUANTA COMPUTER

Title: **Cardbus Controller(R5C554)**

Size B Document Number **JE1.1 Main Board** Rev 2A

(16) ACAD[0..31] <<<

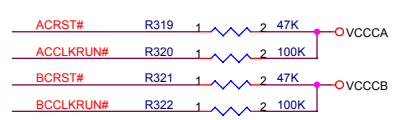
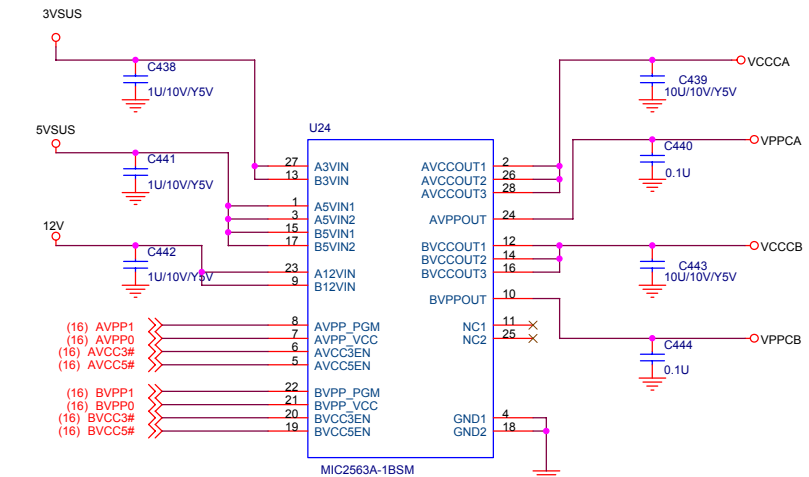
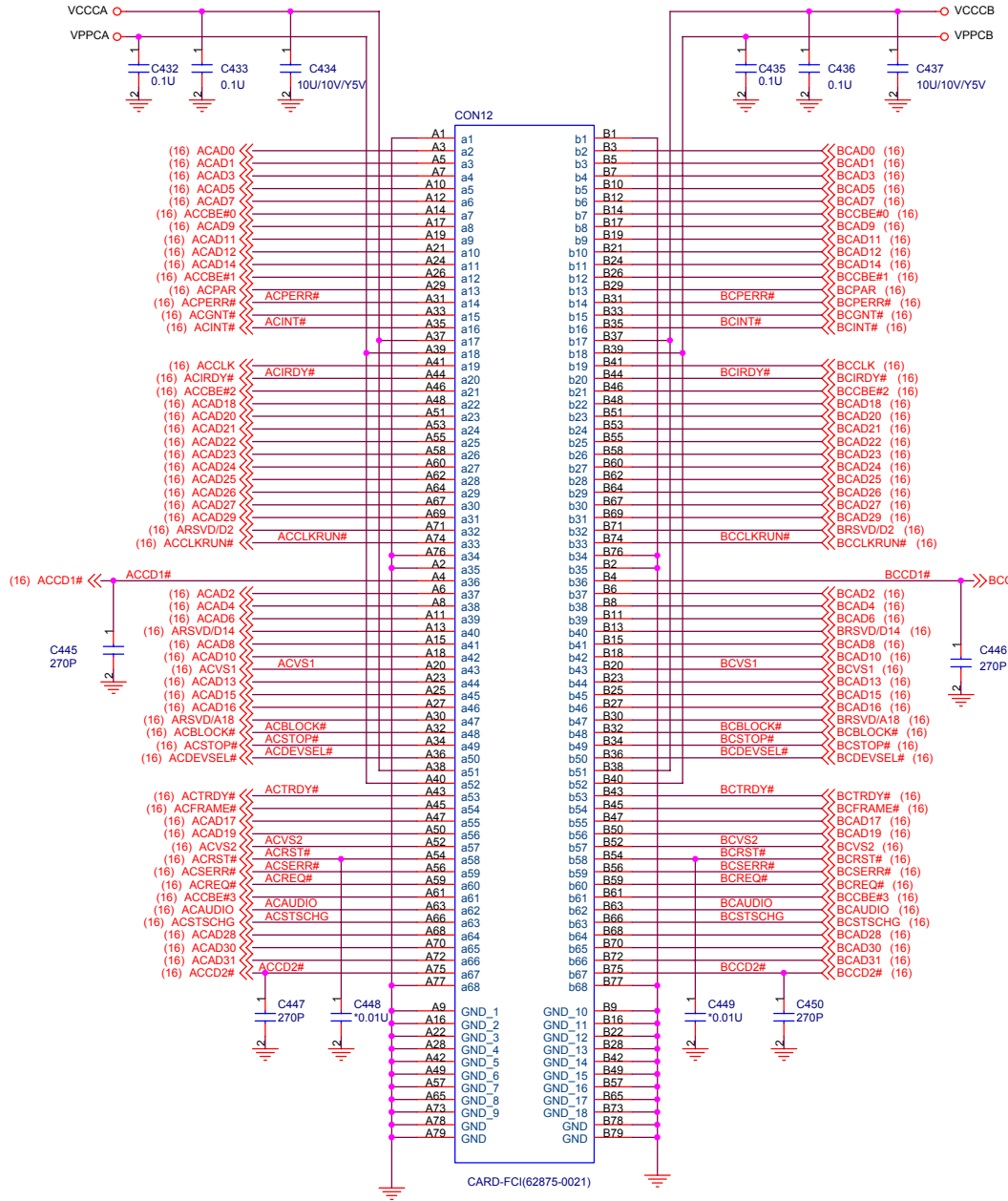

QUANTA COMPUTER

Title: **PCMCIA CONN.**

Size B Document Number **JE1.1 Main Board** Rev 1A

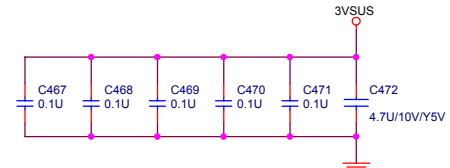
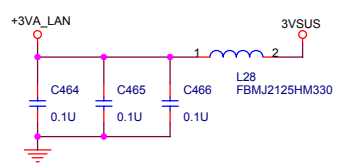
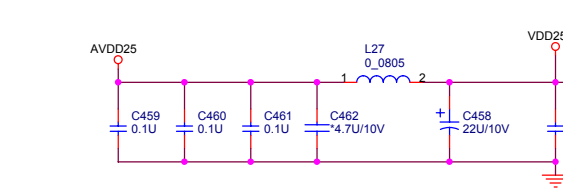
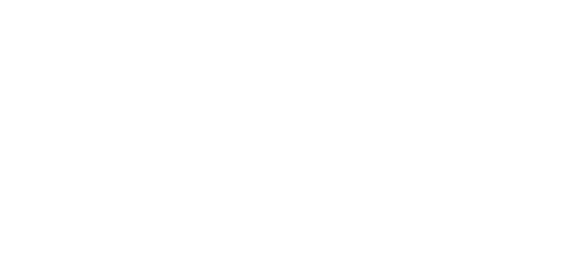
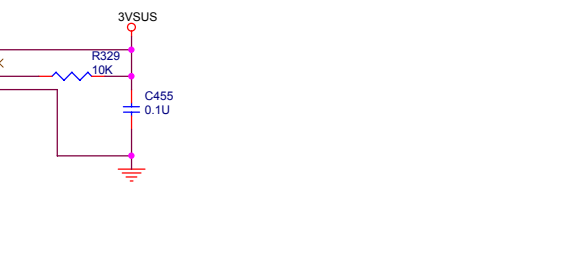
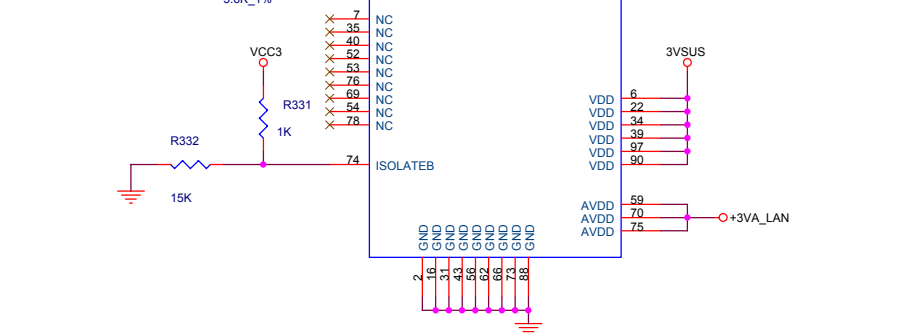
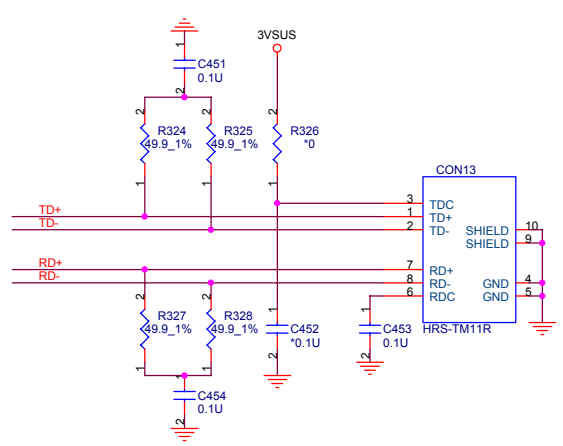
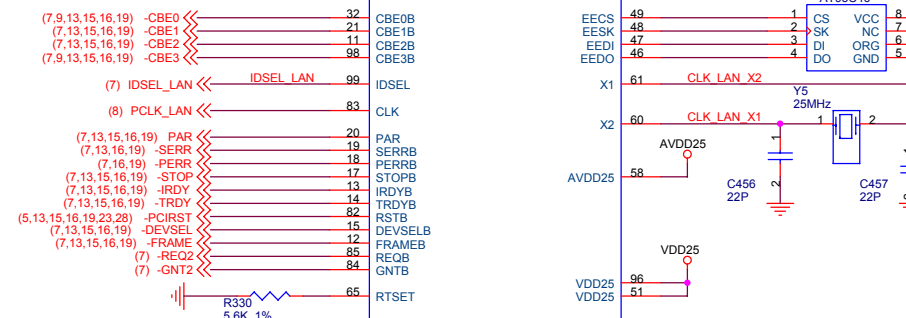
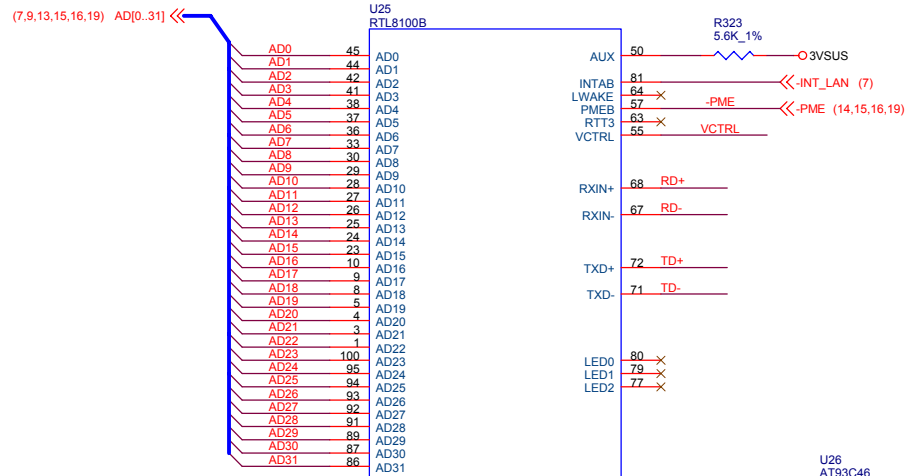

QUANTA COMPUTER

Title: **RTL8100B PCI LAN**

Size B Document Number **JE1.1 Main Board** Rev 2A

Date: 星期二, 四月 22, 2003 Sheet 18 of 30

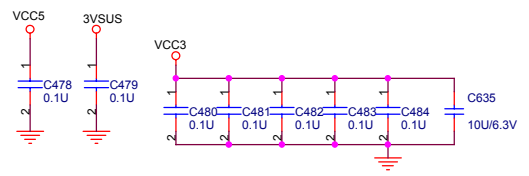
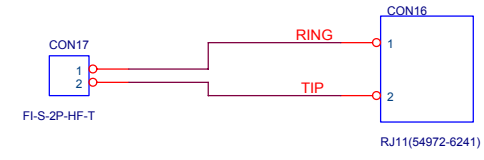
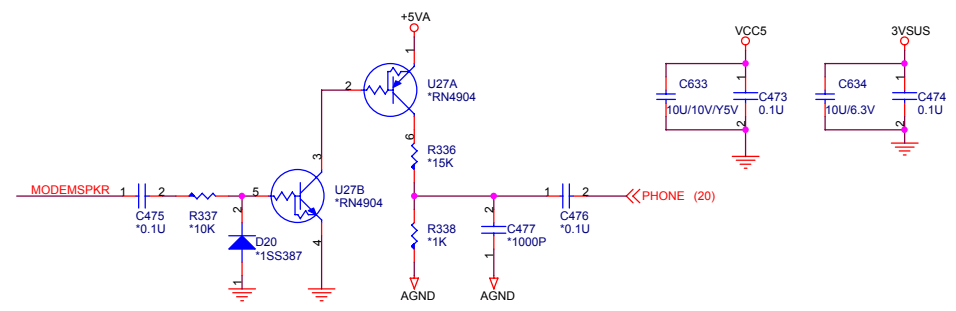
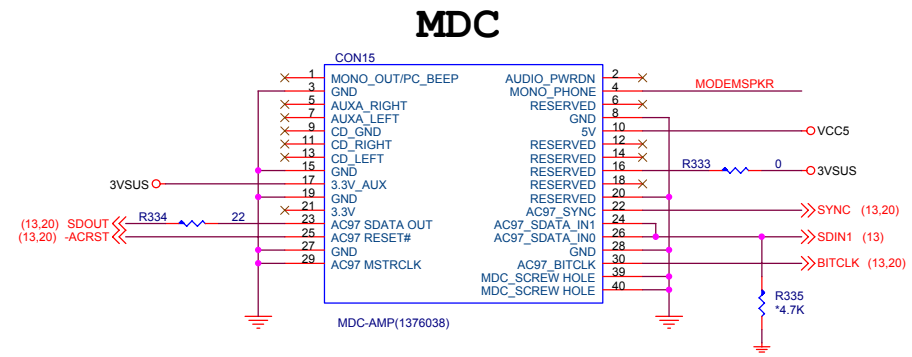
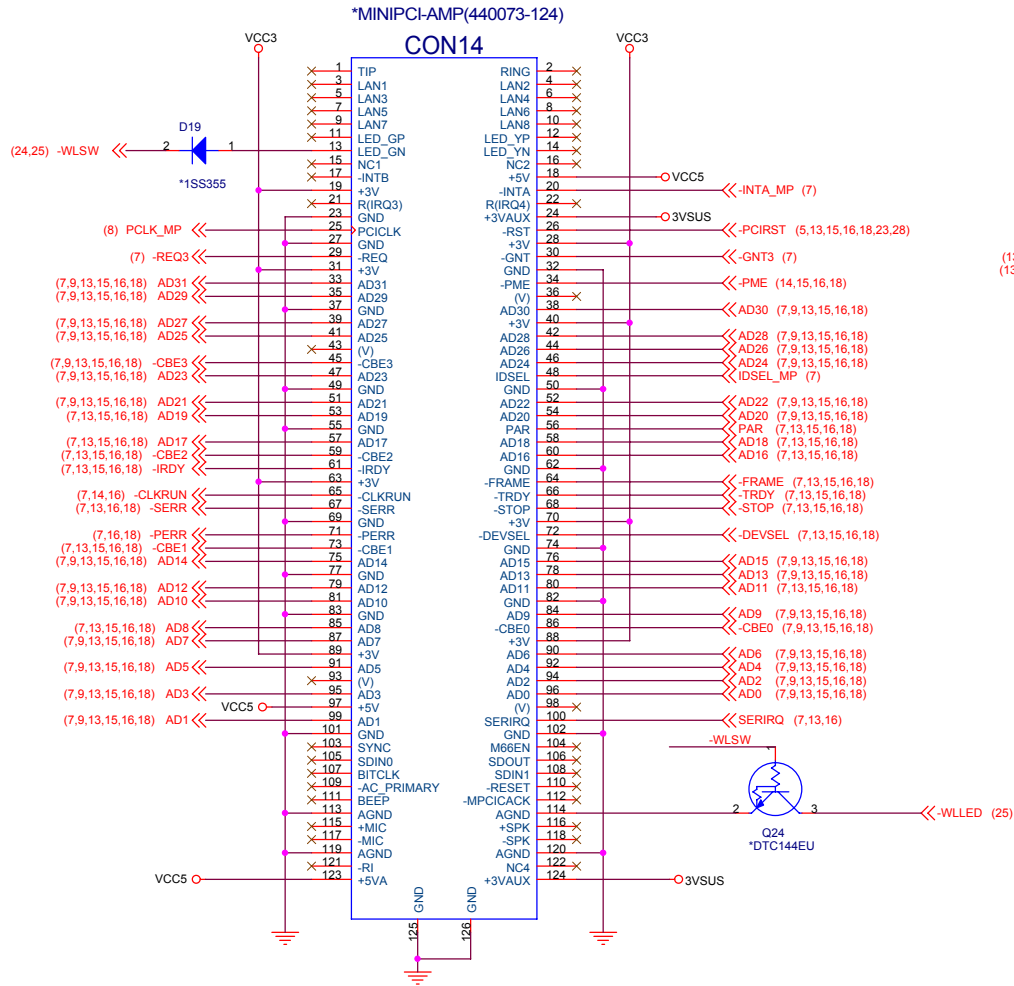

QUANTA COMPUTER

Title: **Mini PCI & MDC**

Size B Document Number **JE1.1 Main Board** Rev 3A

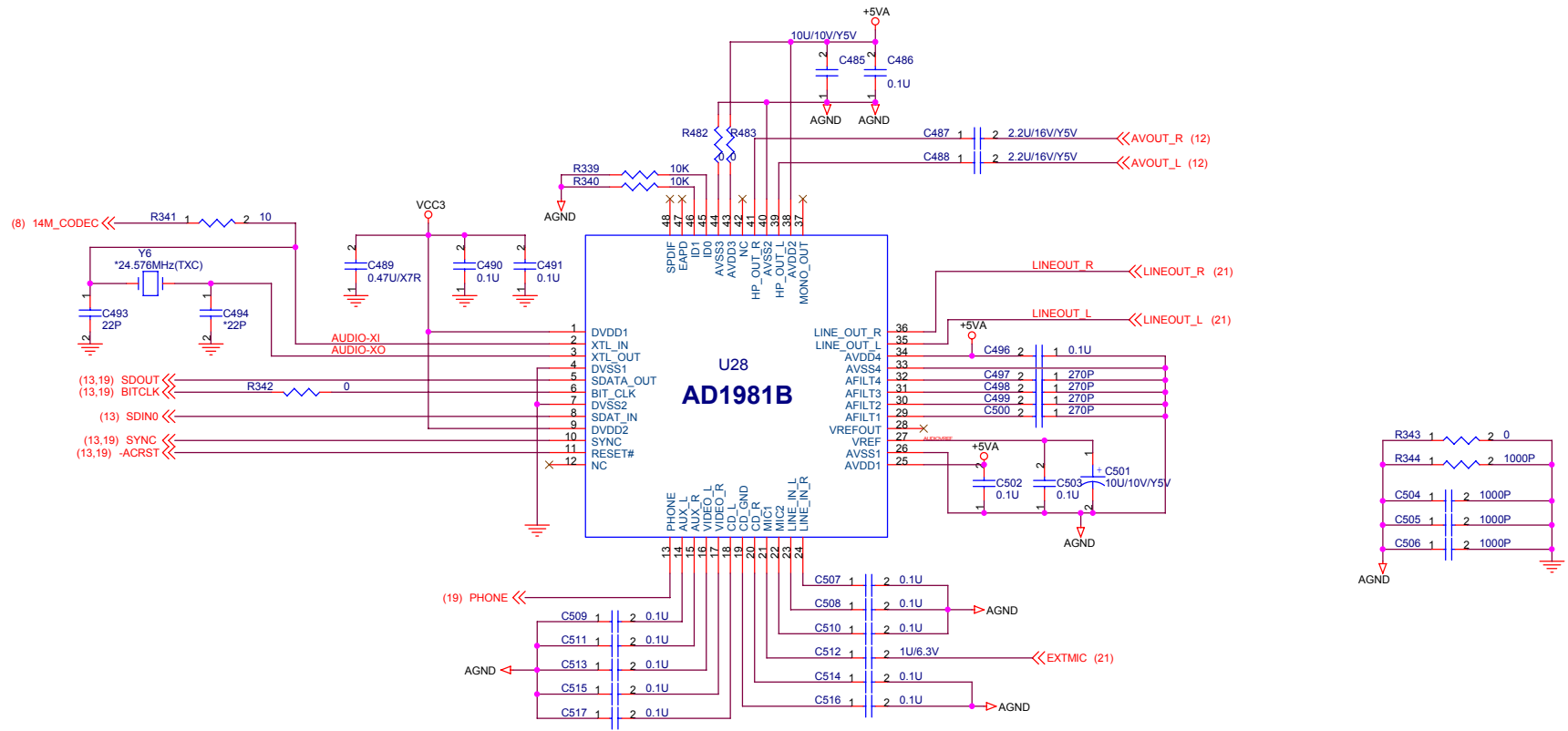

QUANTA COMPUTER

Title: **Audio ADI AD1981A**

Size B | Document Number: **JE1.1 Main Board** | Rev 2A

Date: 星期二, 四月 22, 2003 | Sheet 20 of 30

Audio amplifier

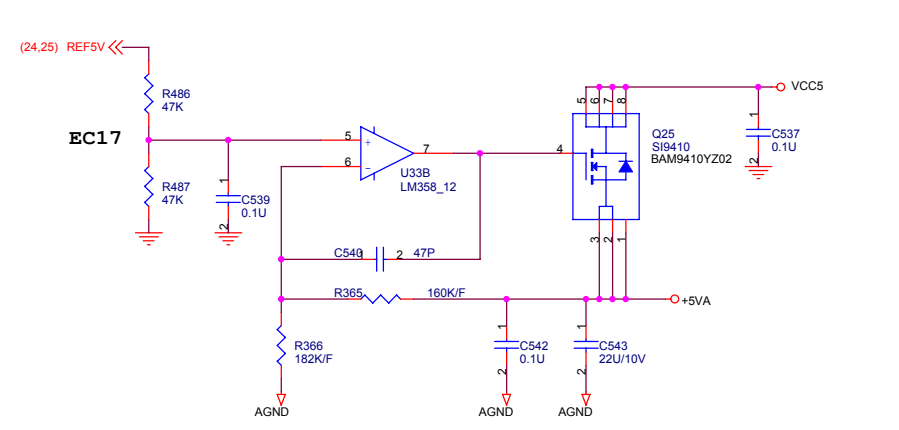
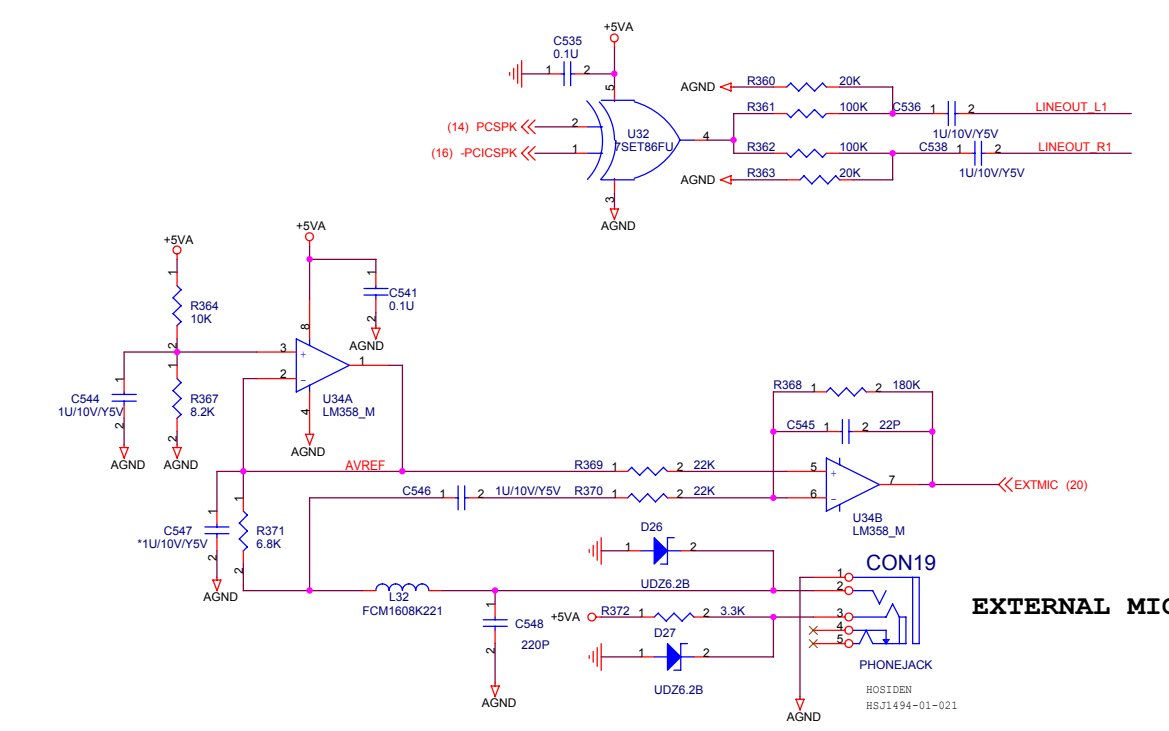
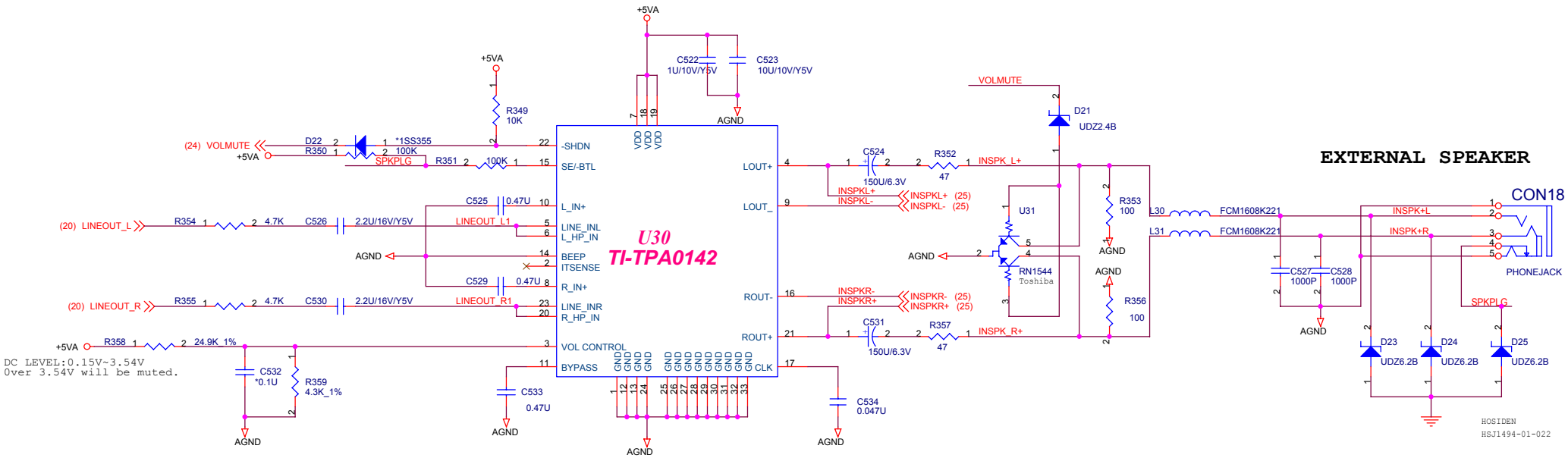

QUANTA COMPUTER

Title: **AUDIO AMP**

Size B Document Number **JE1.1 Main Board** Rev 2A

Date: 星期二, 四月 22, 2003 Sheet 21 of 30

RTC

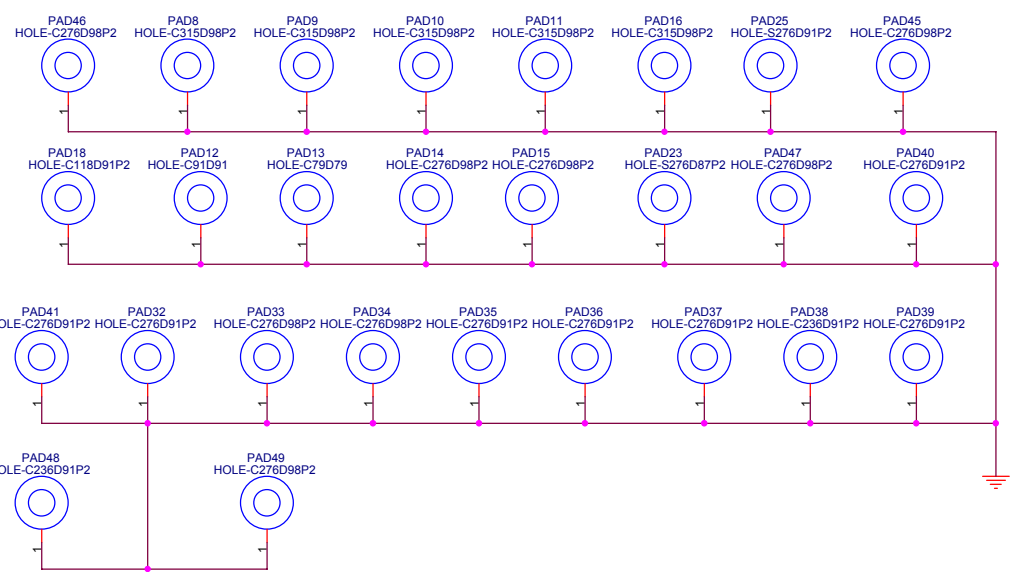
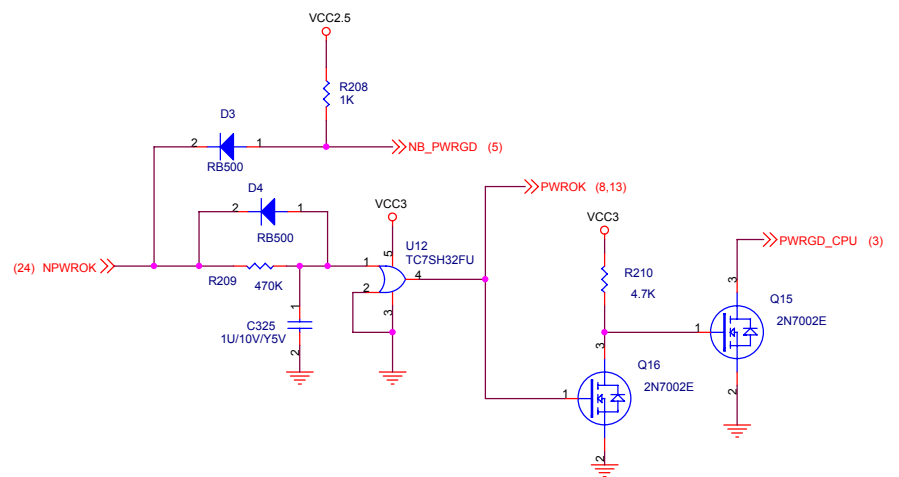
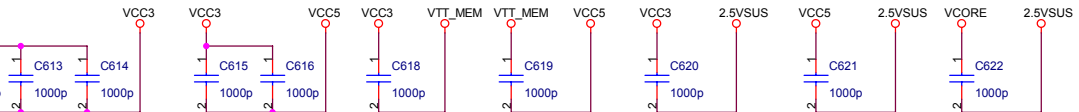
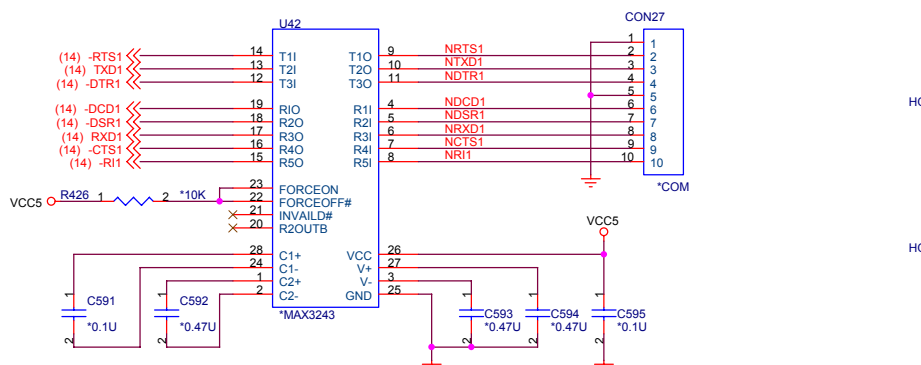
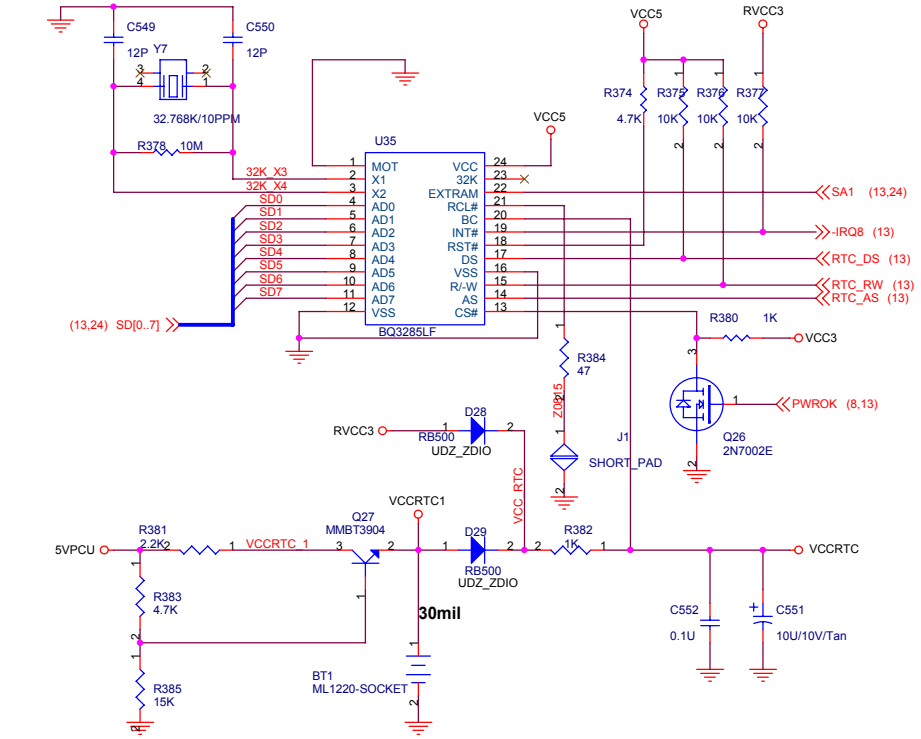

QUANTA COMPUTER

Title: **RTC/POWER GOOD LOGIC**

Size B Document Number **JE1.1 Main Board** Rev 2A

HDD CONNECTOR

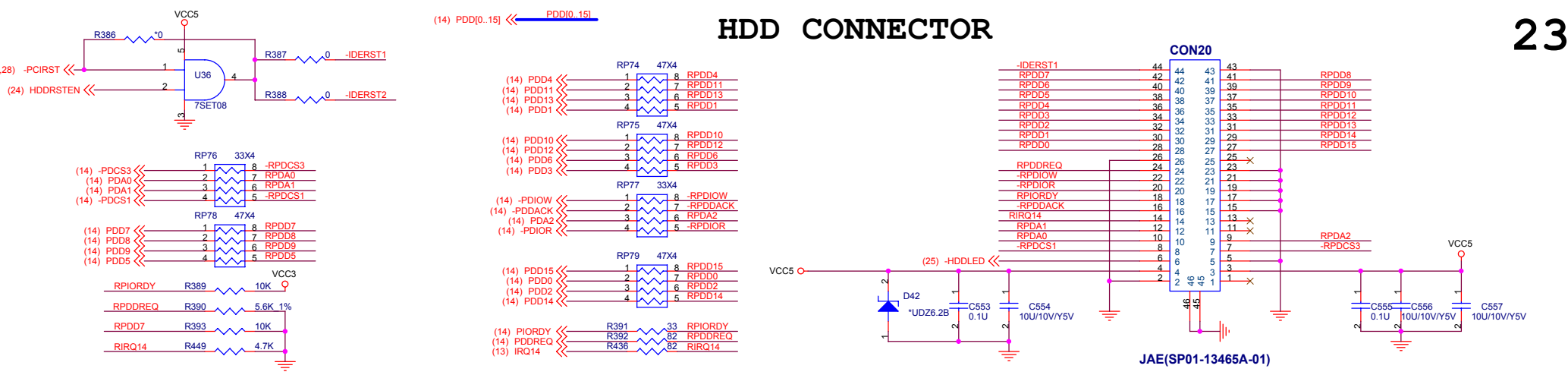

CD-ROM CONNECTOR

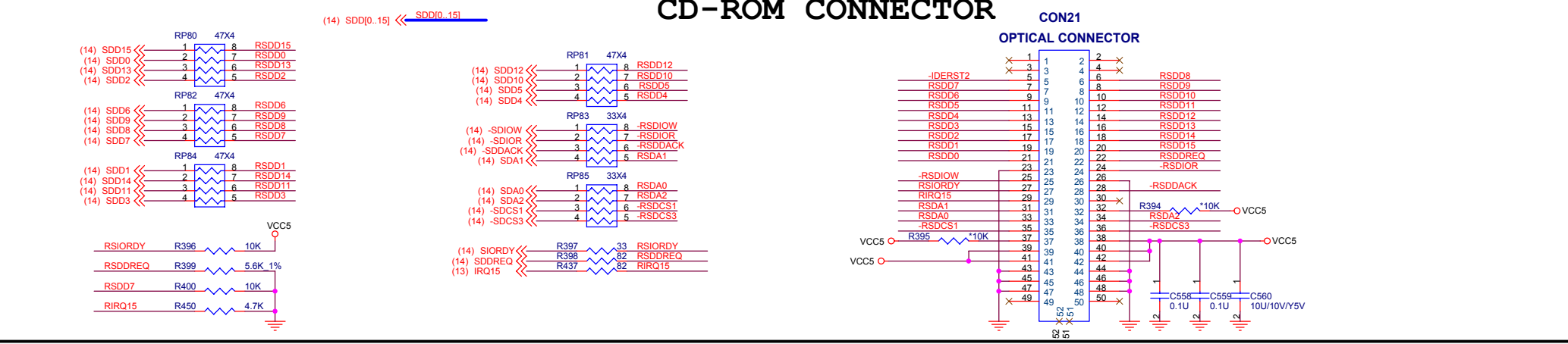

PRINTER port

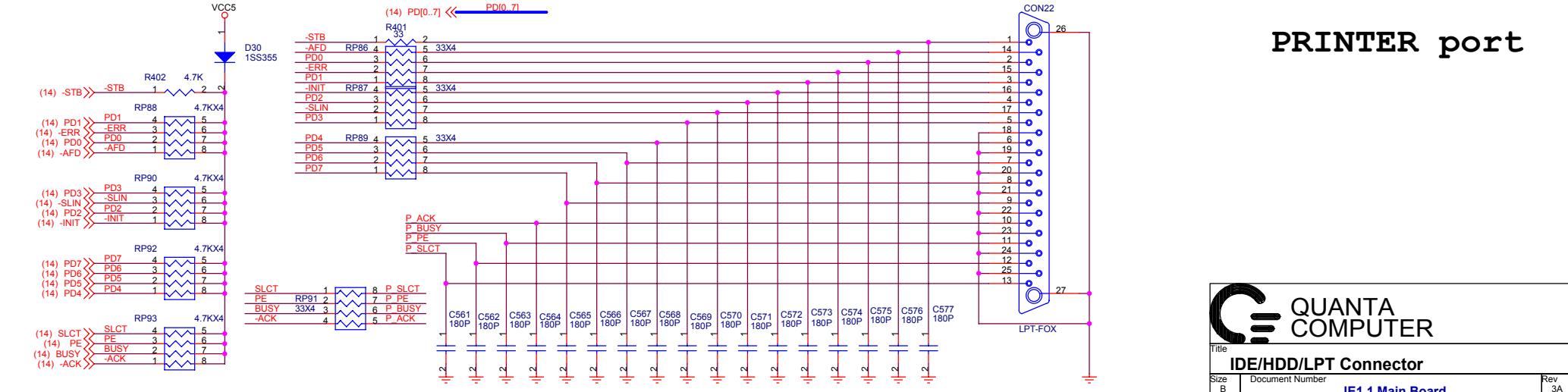

QUANTA COMPUTER

IDE/HDD/LPT Connector

JE1.1 Main Board

Rev 3A

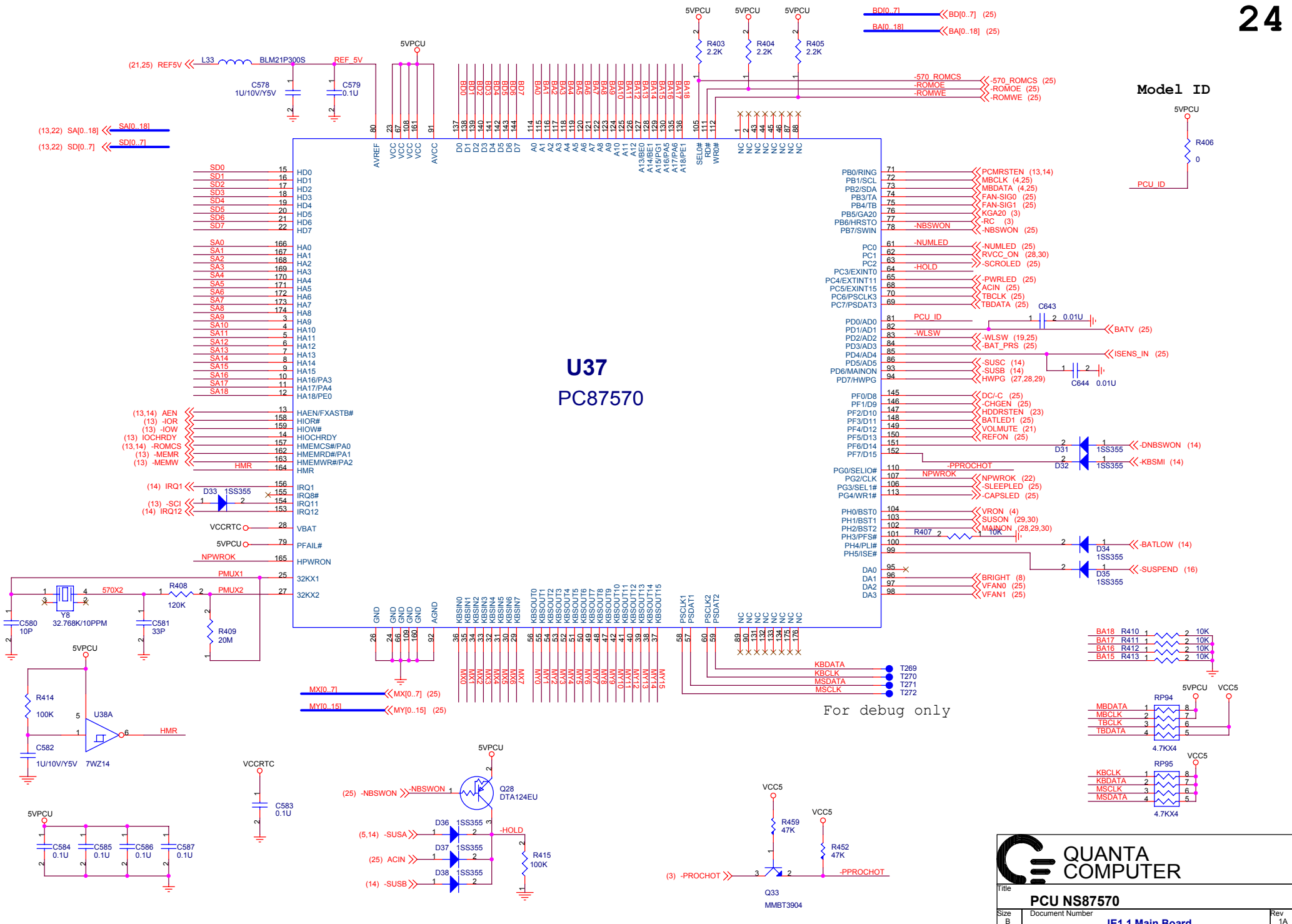

**U37
PC87570**

For debug only

QUANTA COMPUTER

Title: **PCU NS87570**

Size B Document Number **JE1.1 Main Board** Rev 1A

Int. keyboard

BIOS

POWER SWITCH BOARD CONNECTOR

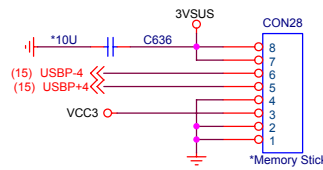
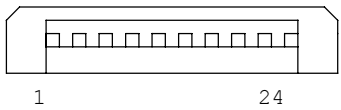
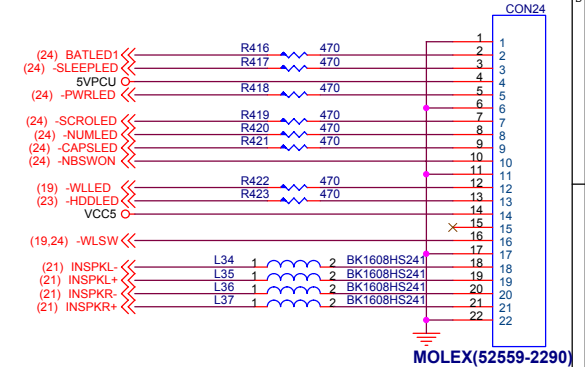
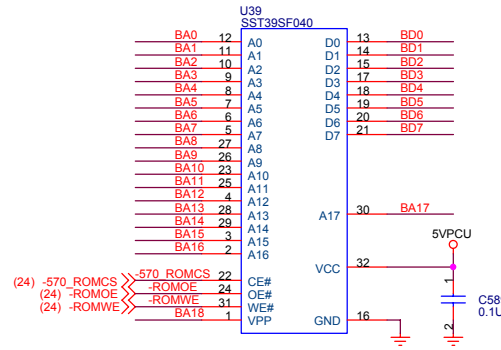
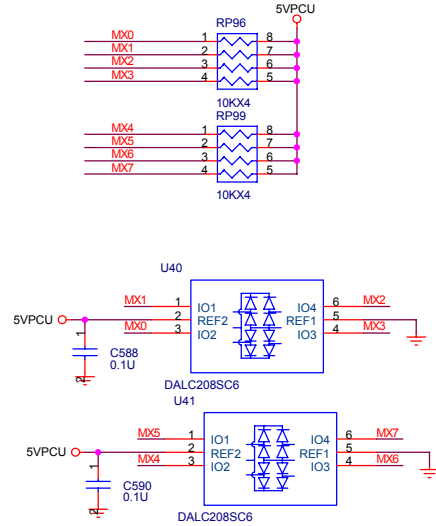
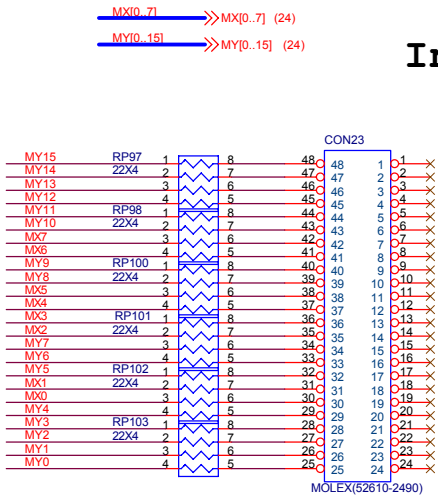

FAN1 UNIT

FAN2 UNIT

CHARGER BOARD CONNECTOR

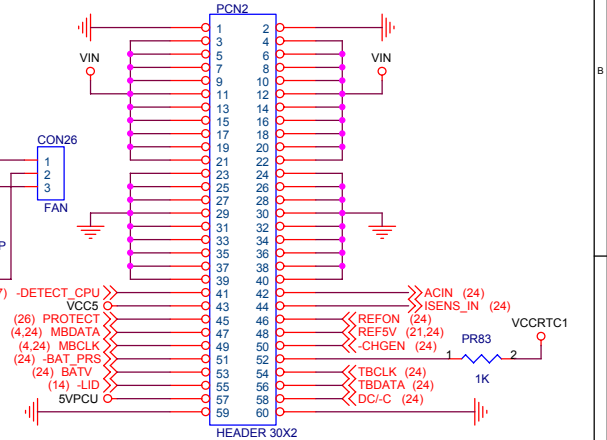
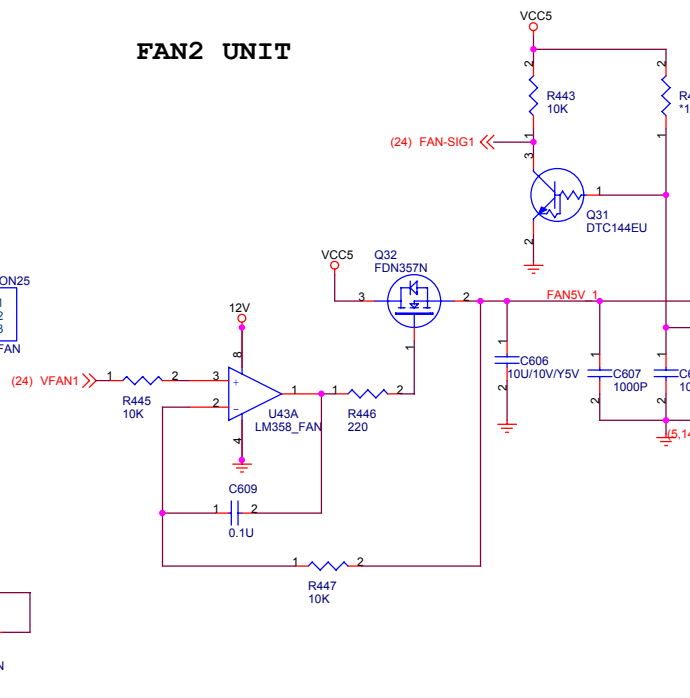
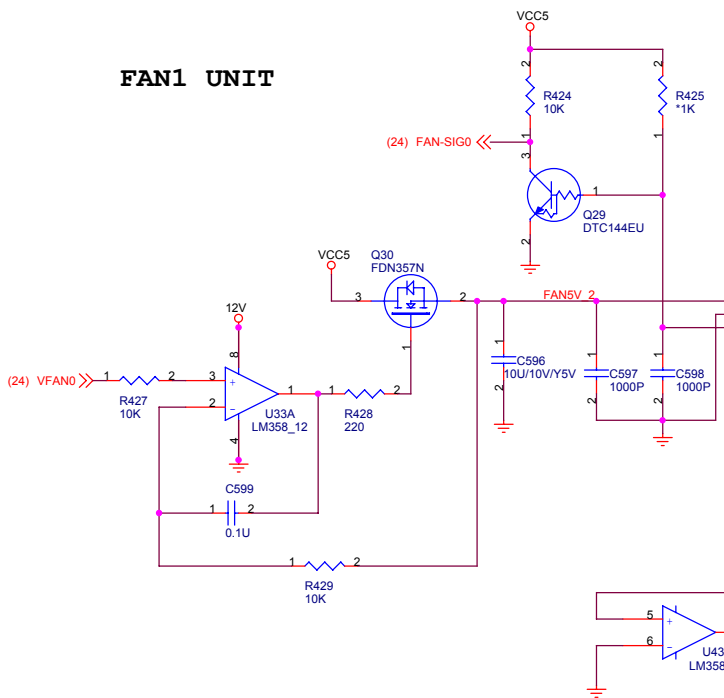

Title		
INT. KEYBOARD/FAN		
Size	Document Number	Rev
Custom	JE1.1 Main Board	3A

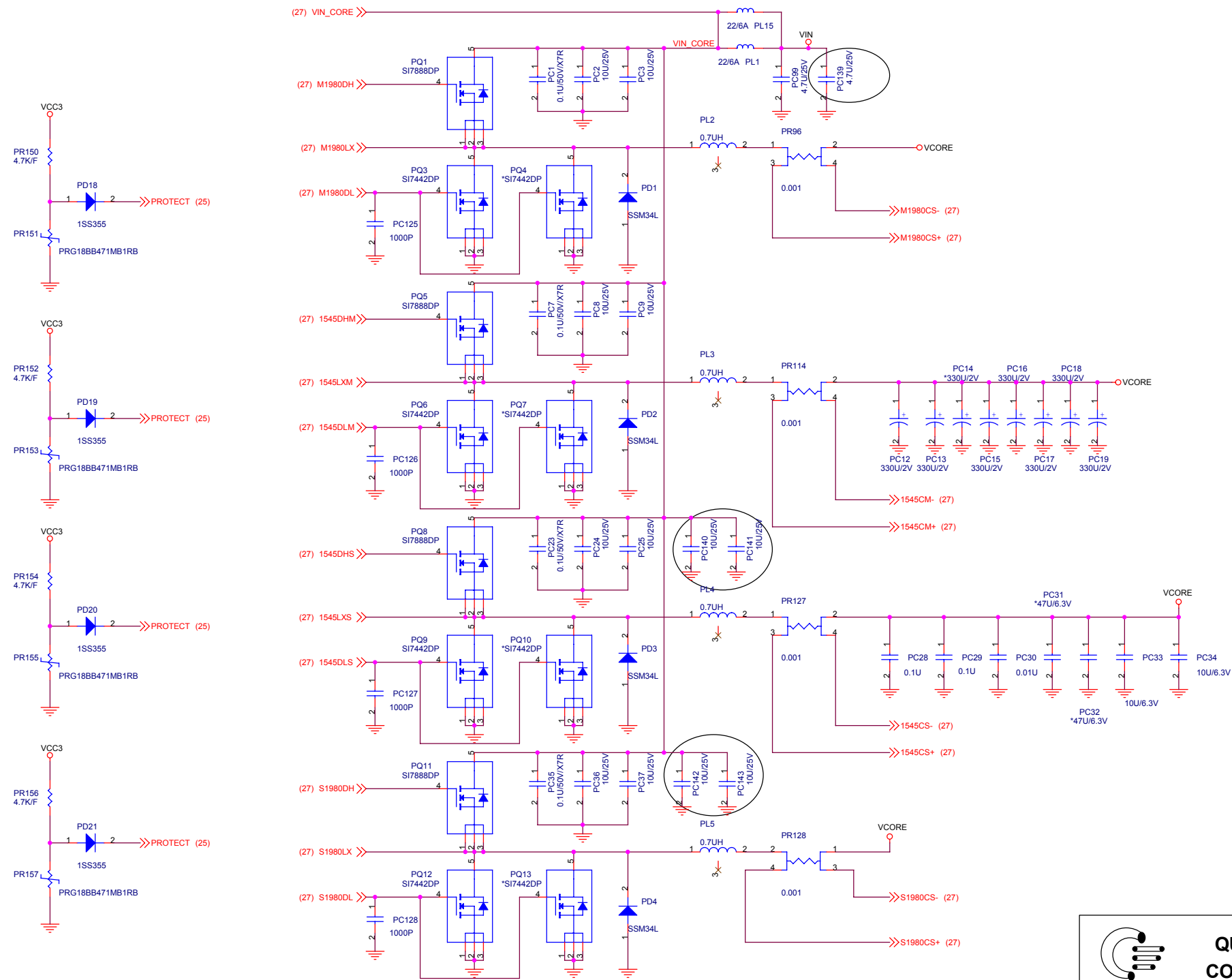

 QUANTA COMPUTER		Size
		Document Number JE1 Main Board
		Rev 3A

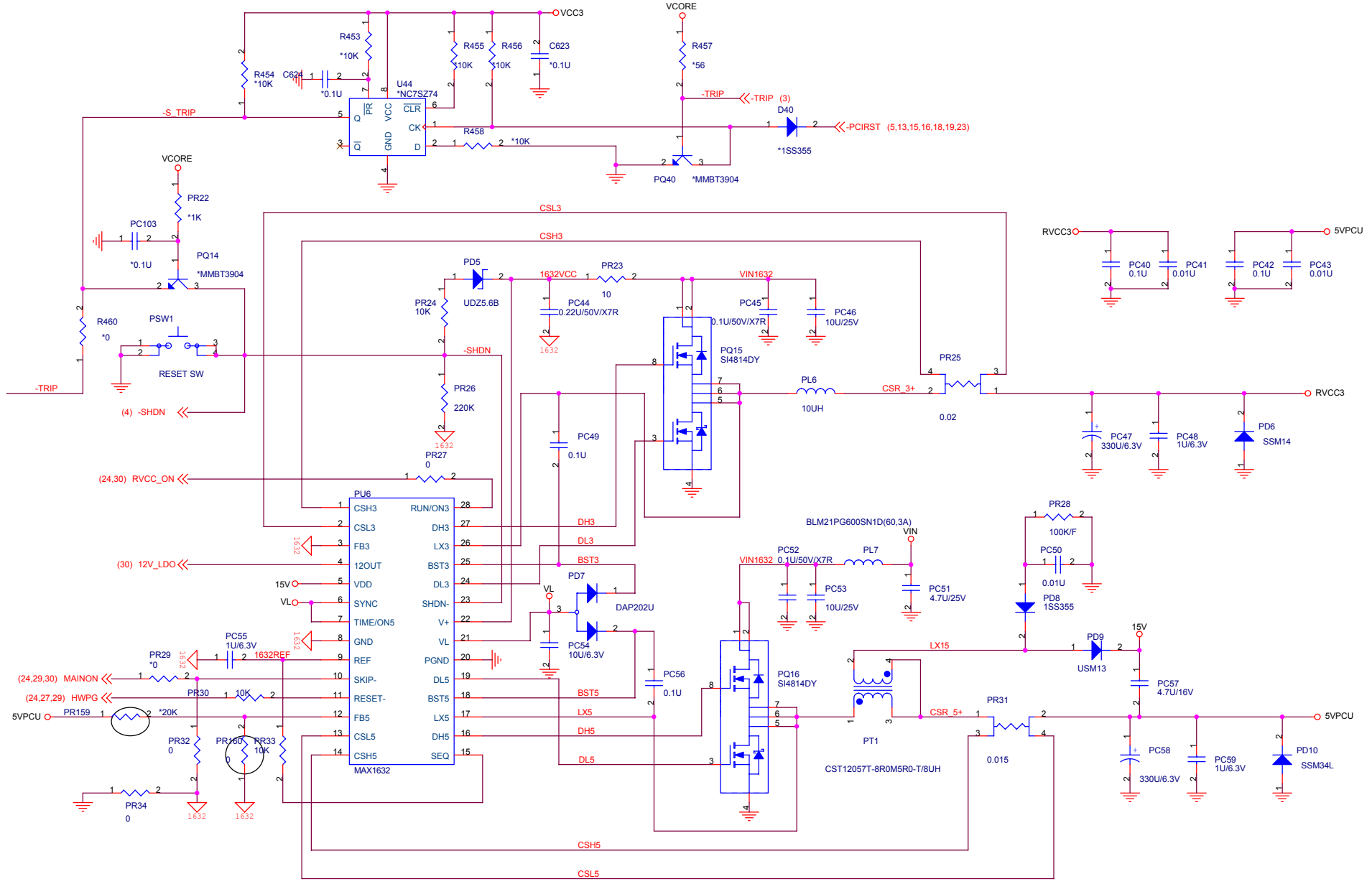



**QUANTA
COMPUTER**

Size	Document Number	Rev
JE1 Main Board	3A	3A

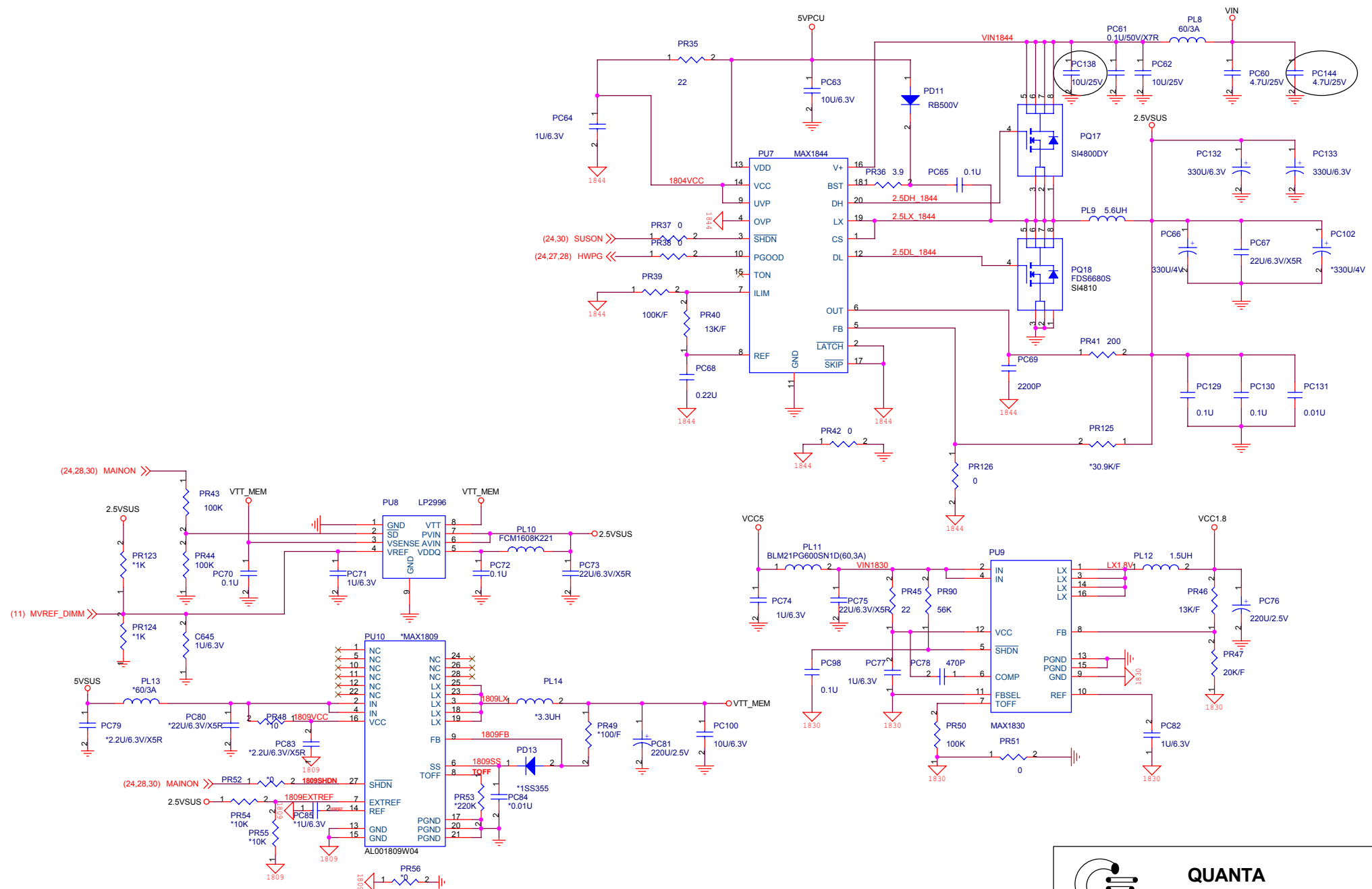



**QUANTA
COMPUTER**

Size	Document Number	Rev
	JE1 Main Board	3A

