

# RB1 Block Diagram

MBX-112

	* GM	GME
1. VCC PR57:	1.2V 17.4K/F	1.35V 14K/F
2. HLRCOMP R91:	27.4/F	37.4/F

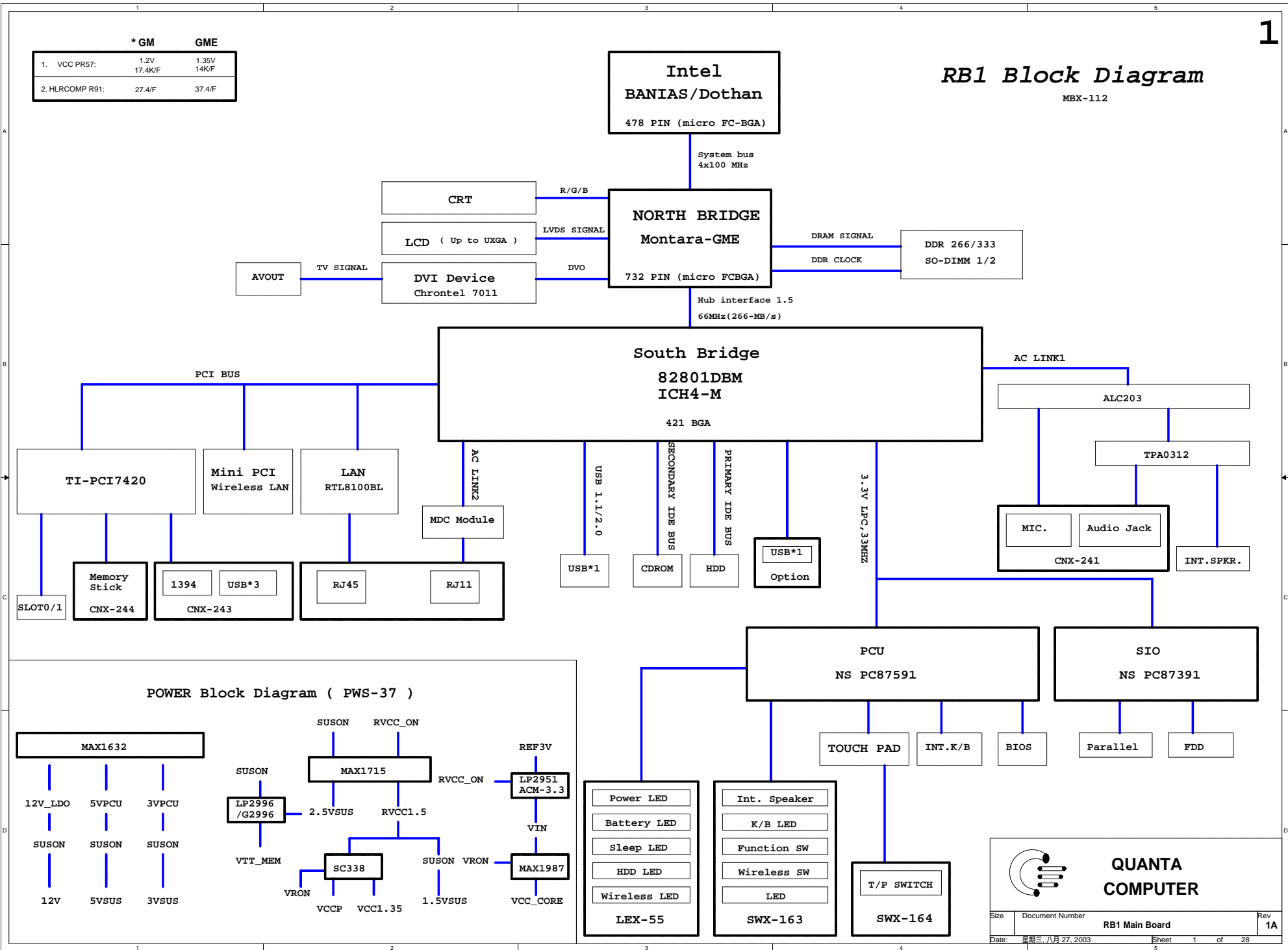

**QUANTA  
COMPUTER**

Size	Document Number	Rev
Date: 星期三, 八月 27, 2003	RB1 Main Board	1A
Sheet 1 of 28		

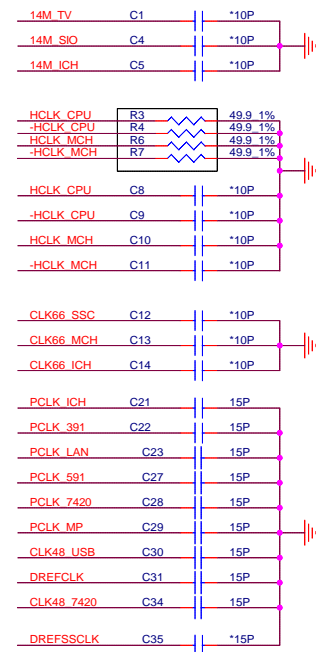
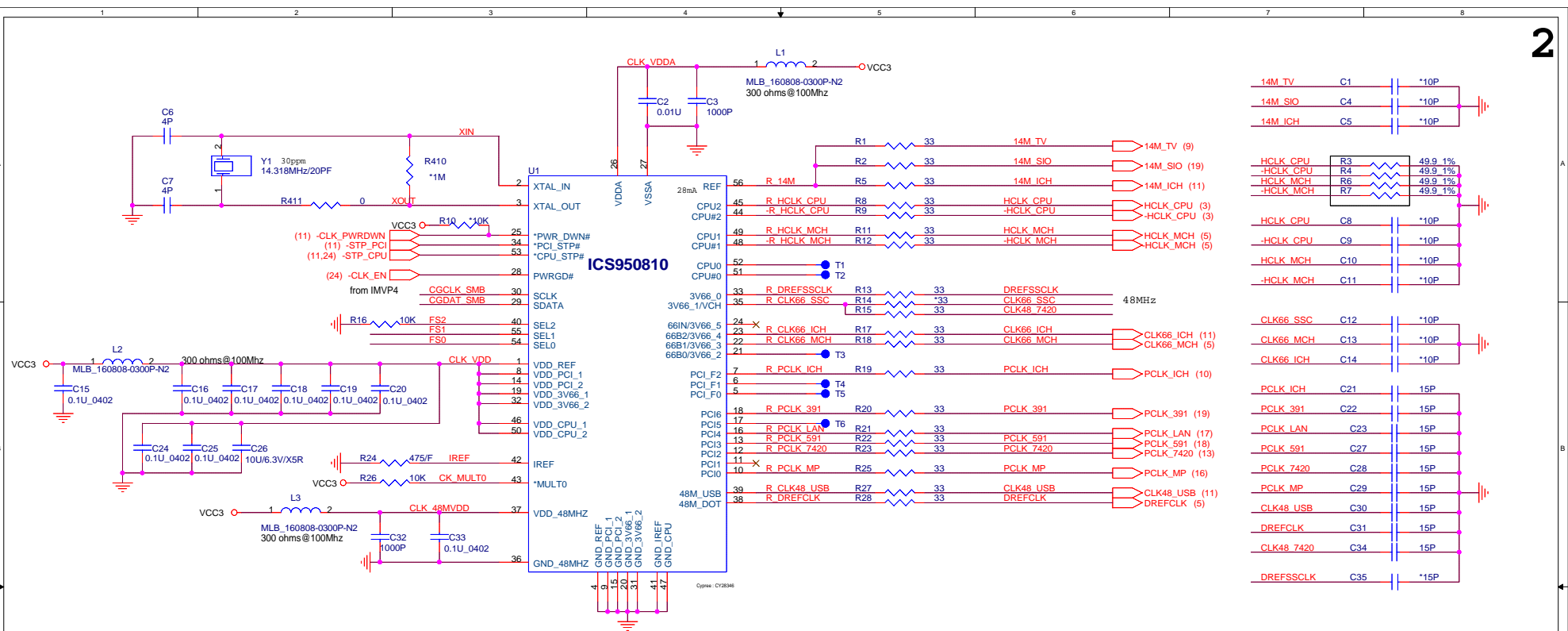

X : Pull high or pull low  
Mid : Pin float

FS2	FS1	FS0	CPU	3V66[5:0]	PCI_F[2:0]
X	0	0	166.66	66.66	33.33
* X	0	1	100.00	66.66	33.33
X	1	0	200.00	66.66	33.33
X	1	1	133.33	66.66	33.33
Mid	0	0	Tristate	Tristate	Tristate
Mid	0	1	TCLK/2	TCLK/4	TCLK/8
Mid	1	0	Reserved	Reserved	Reserved
Mid	1	1	Reserved	Reserved	Reserved

- Use ICS 91718  
Mount : U2, R35, R36, R37, R34, L4, R14  
No mount : R13, R15
- Don't use ICS91718  
Mount : R13, R15  
No mount : U2, R35, R36, R37, R34, L4, R14

\* : Internal pull-up resistor  
\*\* : Internal pull-down resistor

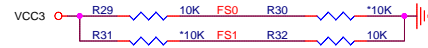

CPUCLK IREF SETUP:

CK_MULT0	IREF	Output Current
0	221 1% Iref=5mA	Ioh = 4*IREF
* 1	475 1% Iref=2.32mA	Ioh = 6*IREF

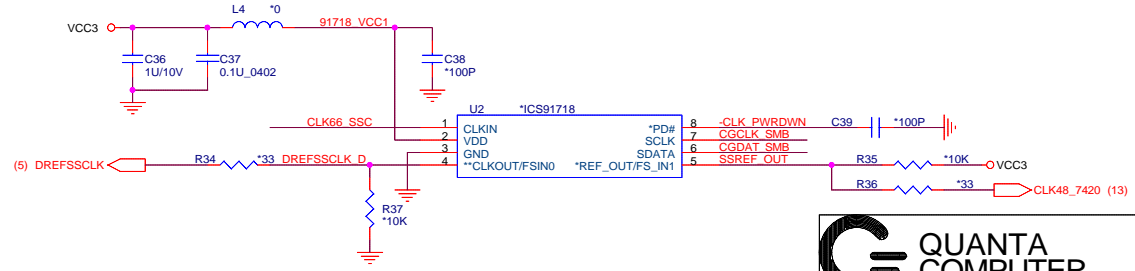
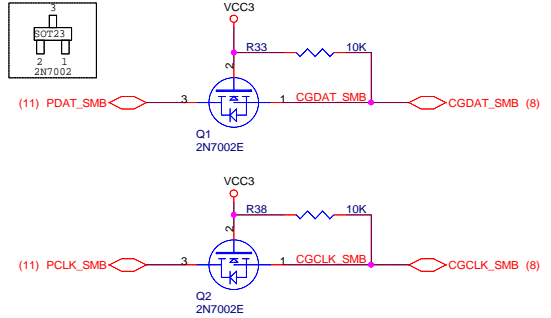

FS InH	FS InO	MHz	SPREAD
0	0	14.318 In 48 Out	-1.0% down Sprd
0	1	14.318 In 66 Out	-1.0% down Sprd
* 1	0	48 In/Out, 66 In/Out	-1.0% down Sprd
1	1	48 In/Out, 66 In/Out	+1.0% down Sprd

THIS PART SHOULD NOT CONTAIN ANY SUBSTANCES WHICH ARE SPECIFIED IN SS-00259-1



Title: **CLOCK GENERATOR**

Size: **RB1 Main Board**

Document Number: **Rev 1A**

Date: 星期二, 九月 02, 2003

Sheet 2 of 28



VCCA:  
 VCC1.5 : Intel Dothan Processor only.  
 VCC1.8 : Intel Dothan/Pentium M Processor only.

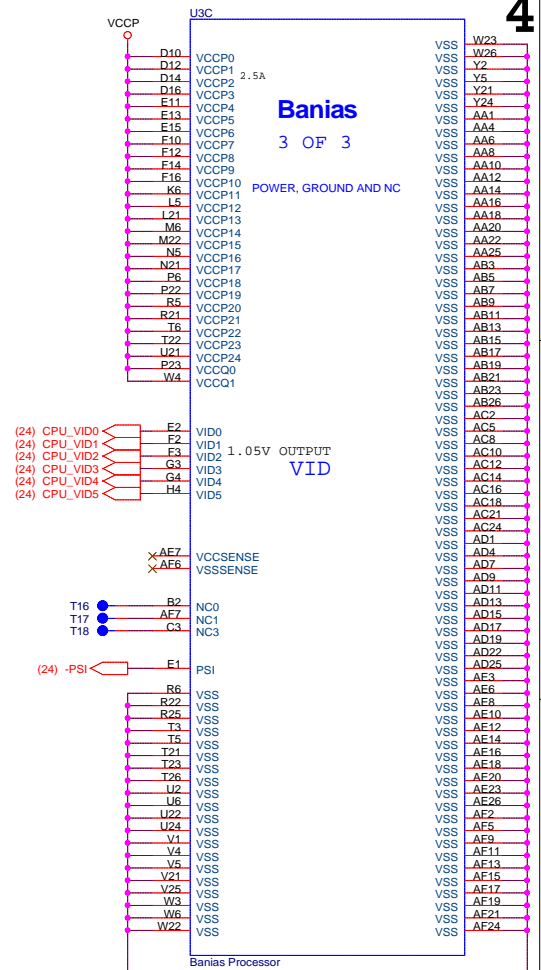
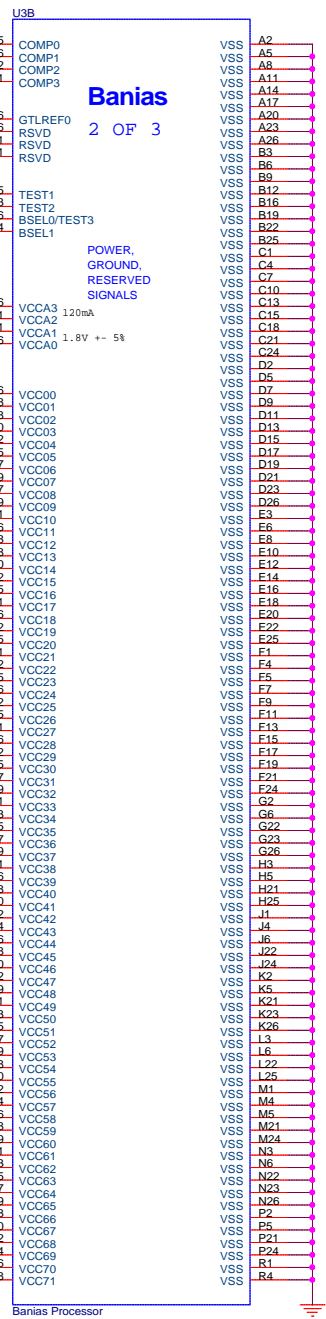
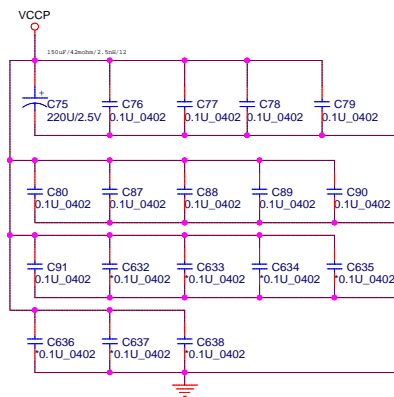
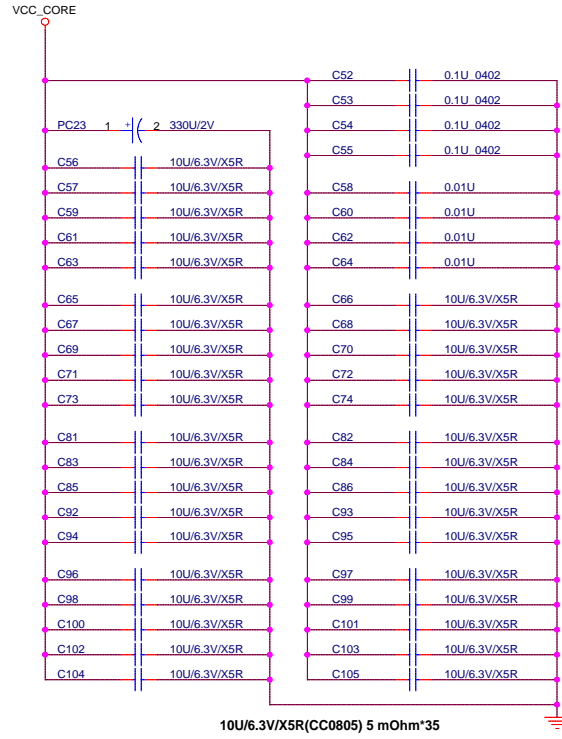
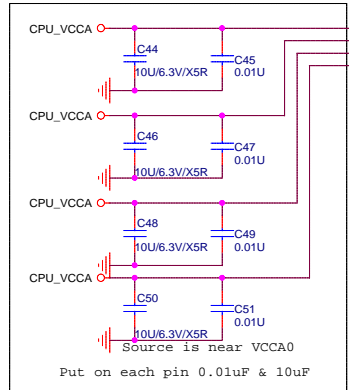
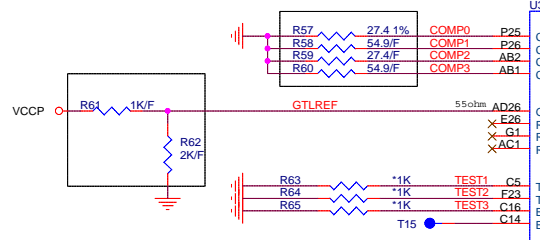
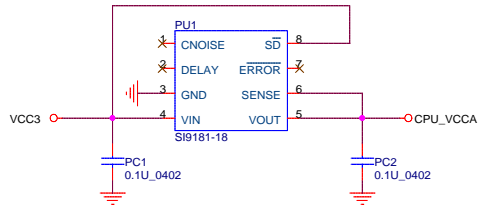

Title		BANIAS CPU-B	
Size	Document Number	Rev	
Custom	RB1 Main Board	1A	
Date:	日期: 九月 03, 2003	Sheet	4 of 28



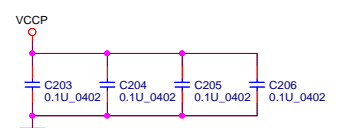
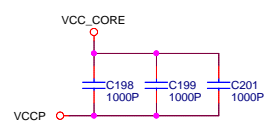
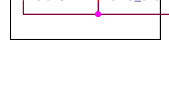
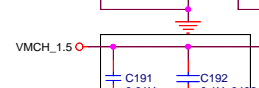
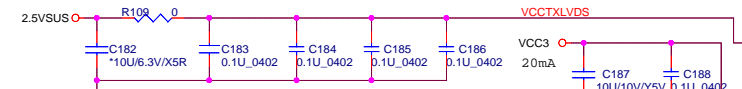
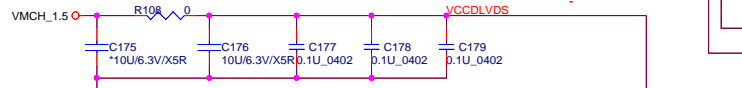
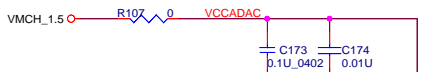
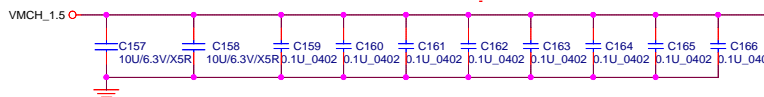
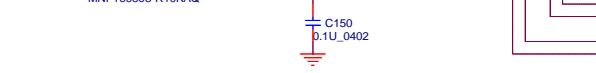
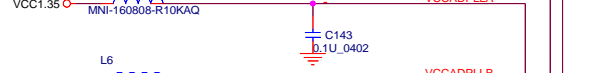
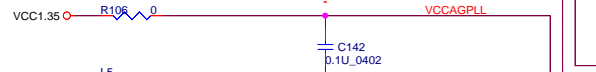
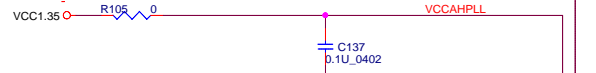
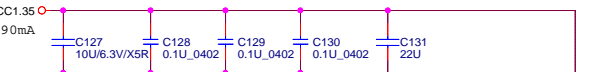
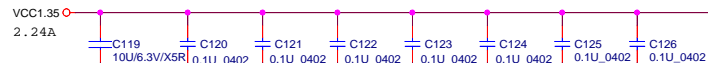

POWER

- W21 VCC0
- AA19 VCC1
- AA17 VCC2
- T17 VCC3
- P17 VCC4
- U16 VCC5
- R16 VCC6
- N16 VCC7
- AA15 VCC7
- T15 VCC9
- P15 VCC10
- J15 VCC11
- U14 VCC12
- R14 VCC13
- N14 VCC14
- H14 VCC15
- V13 VCC16
- P13 VCC17

- V9 VCH0L0
- U8 VCH0L1
- V7 VCH0L2
- U6 VCH0L3
- W5 VCH0L5
- Y1 VCH0L6
- V1 VCH0L7

- D29 VCCAHLL
- Y2 VCCAGPLL
- A6 VCCADPLLA
- B16 VCCADPLLB

- P9 VCCDV00
- M9 VCCDV01
- K9 VCCDV02
- R8 VCCDV03
- N8 VCCDV04
- M8 VCCDV05
- J8 VCCDV06
- L8 VCCDV07
- H7 VCCDV08
- E6 VCCDV09
- M4 VCCDV010
- J4 VCCDV011
- E4 VCCDV012
- N1 VCCDV013
- J1 VCCDV014
- E1 VCCDV015

- B9 VCCADAC0
- A9 VCCADAC1
- B8 VSSADAC

- B15 VCCDLVDS0
- B14 VCCDLVDS1
- J13 VCCDLVDS2
- G13 VCCDLVDS3

- A12 VCCXLVDS0
- D10 VCCXLVDS1
- B10 VCCXLVDS2
- F9 VCCXLVDS3

- A4 VCCGPI00
- A3 VCCGPI01

- A11 VCCALVDS
- B11 VSSALVDS

- V29 VTTHF0
- M29 VTTHF1
- H29 VTTHF2
- A24 VTTHF3
- A22 VTTHF4

- V29 VTTHF0
- M29 VTTHF1
- H29 VTTHF2
- A24 VTTHF3
- A22 VTTHF4

- V29 VTTHF0
- M29 VTTHF1
- H29 VTTHF2
- A24 VTTHF3
- A22 VTTHF4

- V29 VTTHF0
- M29 VTTHF1
- H29 VTTHF2
- A24 VTTHF3
- A22 VTTHF4

- V29 VTTHF0
- M29 VTTHF1
- H29 VTTHF2
- A24 VTTHF3
- A22 VTTHF4

- V29 VTTHF0
- M29 VTTHF1
- H29 VTTHF2
- A24 VTTHF3
- A22 VTTHF4

- VTTLF0
- VTTLF1
- VTTLF2
- VTTLF3
- VTTLF4
- VTTLF5
- VTTLF6
- VTTLF7
- VTTLF8
- VTTLF9
- VTTLF10
- VTTLF11
- VTTLF12
- VTTLF13
- VTTLF14
- VTTLF15
- VTTLF16
- VTTLF17
- VTTLF18
- VTTLF19
- VTTLF20

- VCCSM0
- VCCSM1
- VCCSM2
- VCCSM3
- VCCSM4
- VCCSM5
- VCCSM6
- VCCSM7
- VCCSM8
- VCCSM9
- VCCSM10
- VCCSM11
- VCCSM12
- VCCSM13
- VCCSM14
- VCCSM15
- VCCSM16
- VCCSM17
- VCCSM18
- VCCSM19
- VCCSM20
- VCCSM21
- VCCSM22
- VCCSM23
- VCCSM24
- VCCSM25
- VCCSM26
- VCCSM27
- VCCSM28
- VCCSM29
- VCCSM30
- VCCSM31
- VCCSM32
- VCCSM33
- VCCSM34
- VCCSM35
- VCCSM36

- V29 VTTHF0
- M29 VTTHF1
- H29 VTTHF2
- A24 VTTHF3
- A22 VTTHF4

- V29 VTTHF0
- M29 VTTHF1
- H29 VTTHF2
- A24 VTTHF3
- A22 VTTHF4

- V29 VTTHF0
- M29 VTTHF1
- H29 VTTHF2
- A24 VTTHF3
- A22 VTTHF4

- V29 VTTHF0
- M29 VTTHF1
- H29 VTTHF2
- A24 VTTHF3
- A22 VTTHF4

- V29 VTTHF0
- M29 VTTHF1
- H29 VTTHF2
- A24 VTTHF3
- A22 VTTHF4

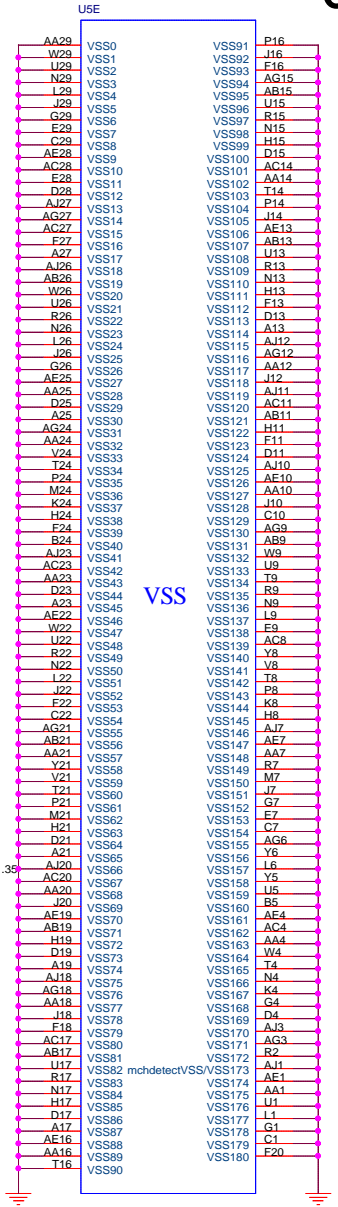
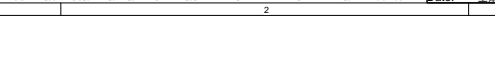
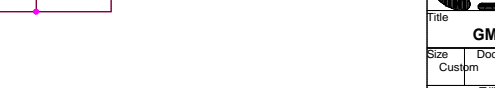
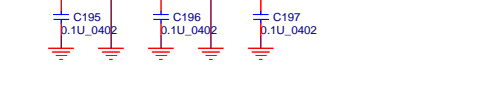
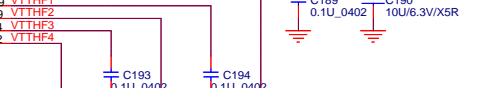
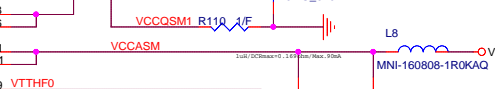
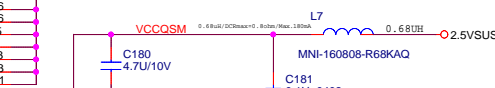
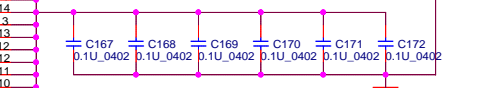
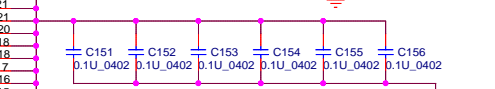
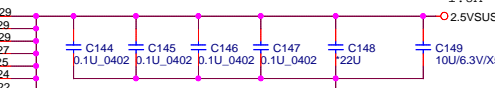
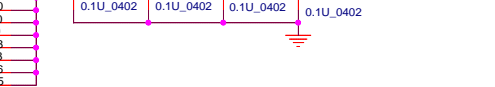
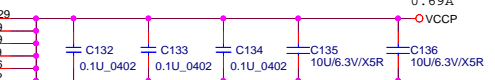

**QUANTA COMPUTER**

Title: GMCH-M\_B(VCC,GND)

Size: Document Number

Custom: RB1 Main Board

Date: 星期四, 九月 04, 2003

Sheet: 6 of 28

Rev: 1A



# DDR - Modules

## CON1 DDR\_SODIMM-STD

## CON2 DDR\_SODIMM-RVS

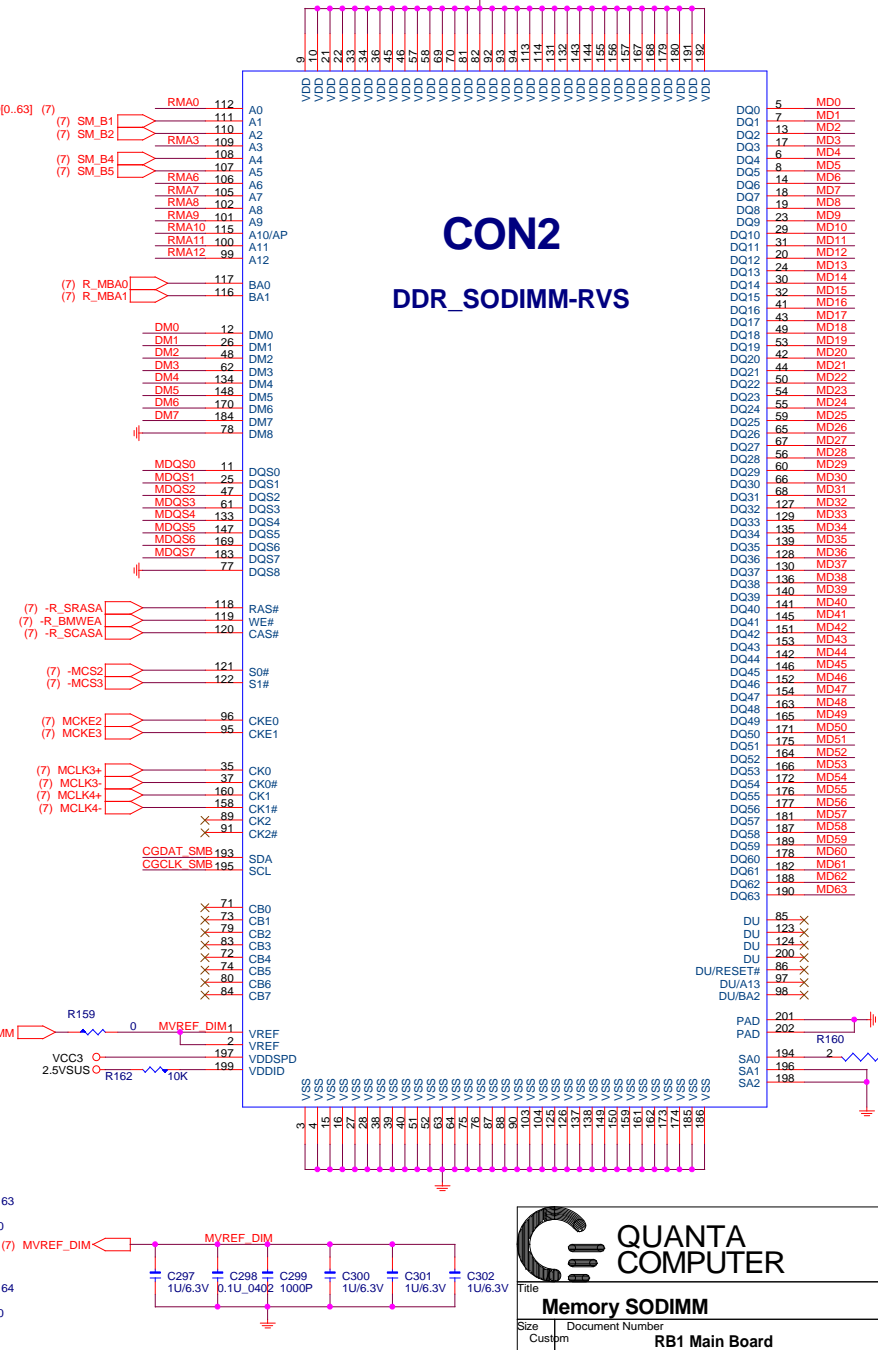
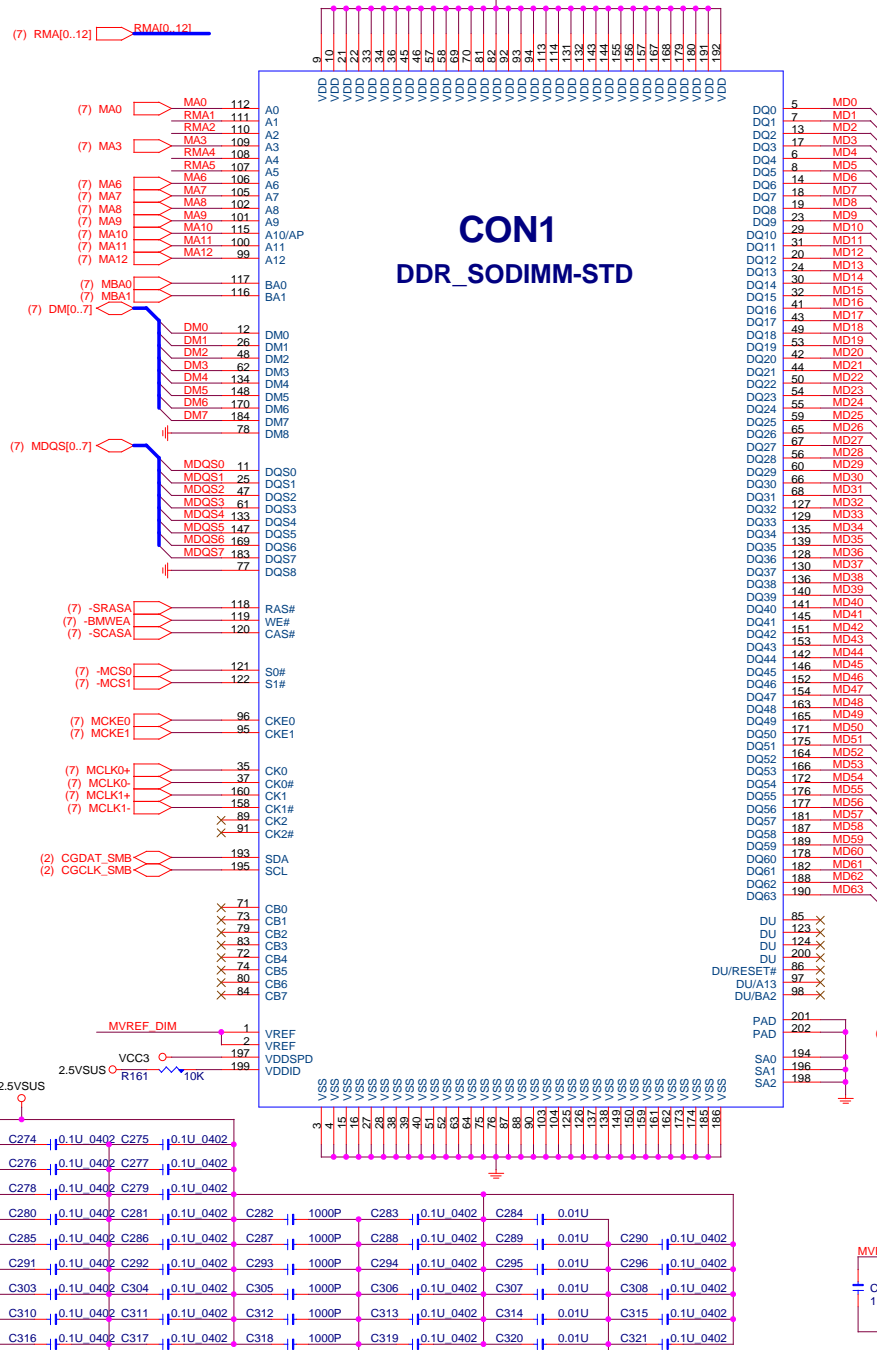

Title		Rev
Memory SODIMM		1A
Size	Document Number	
Custom	RB1 Main Board	



Pin8(GPIO0) : \*Low(330)=NTSC  
 High(10K)=PAL  
 Pin10(AS) : CH7011 Address  
 \*Low(330)=OX76  
 High(10K)=OX75

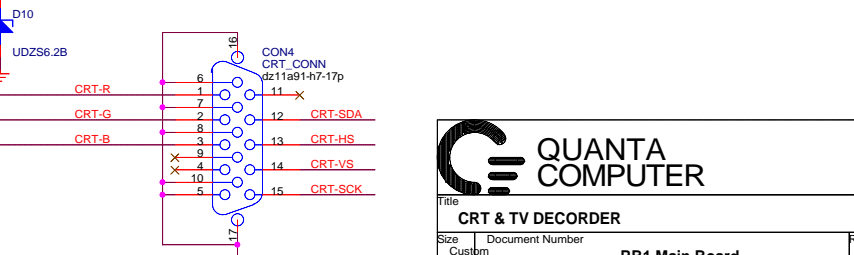
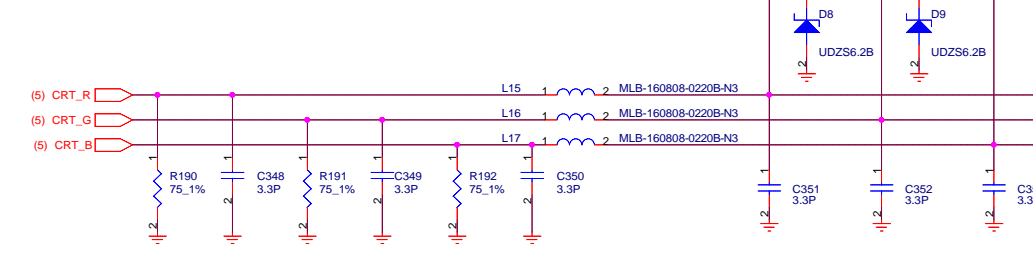
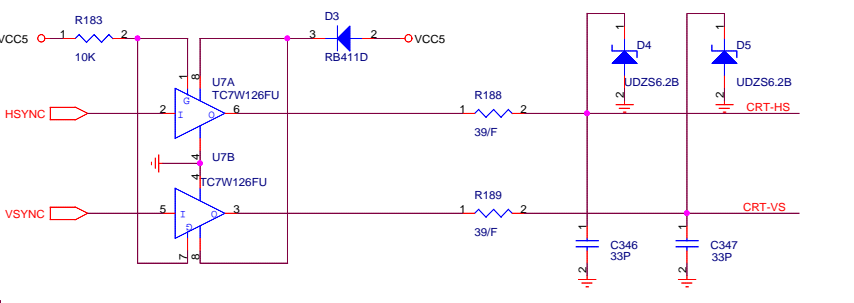
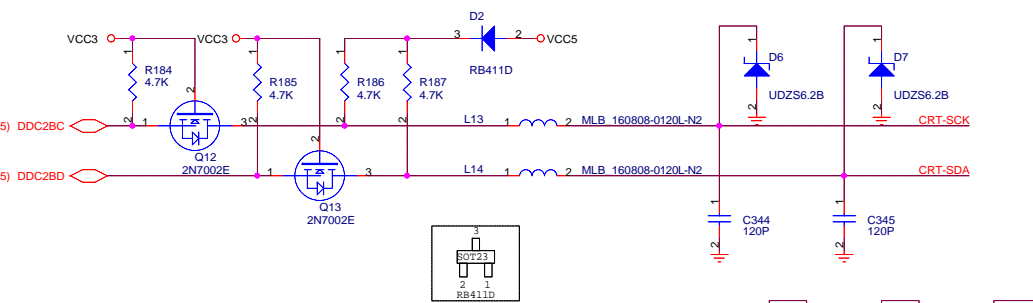
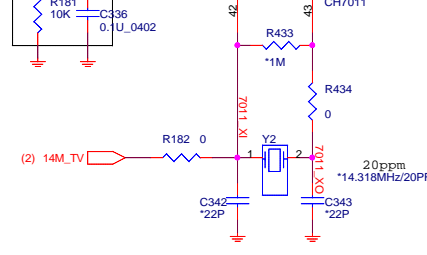
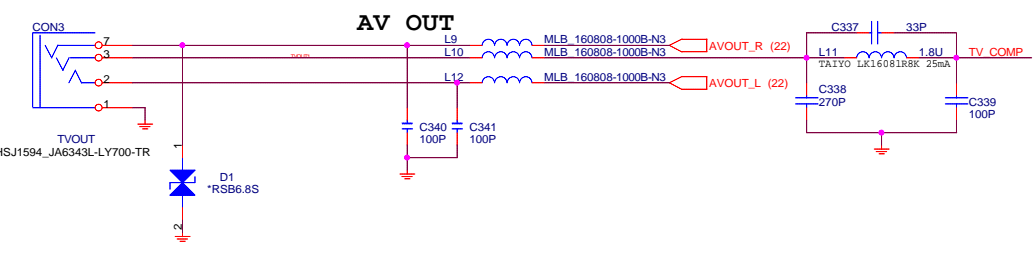
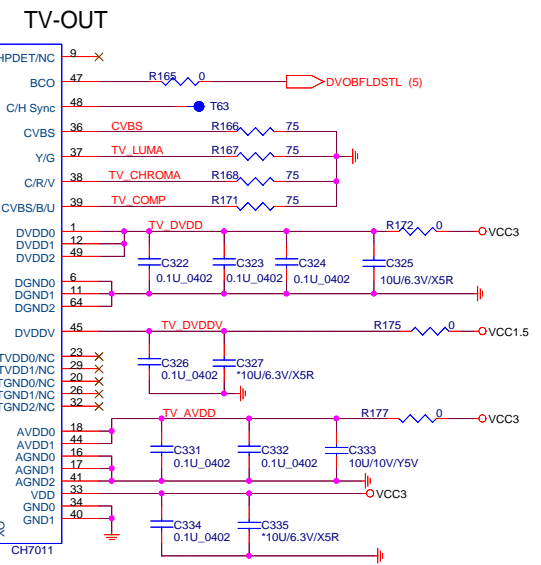
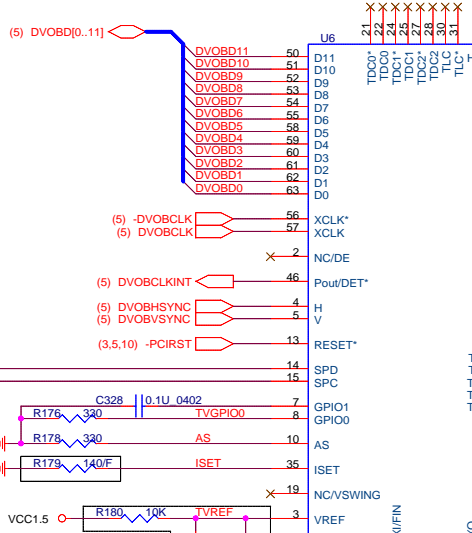
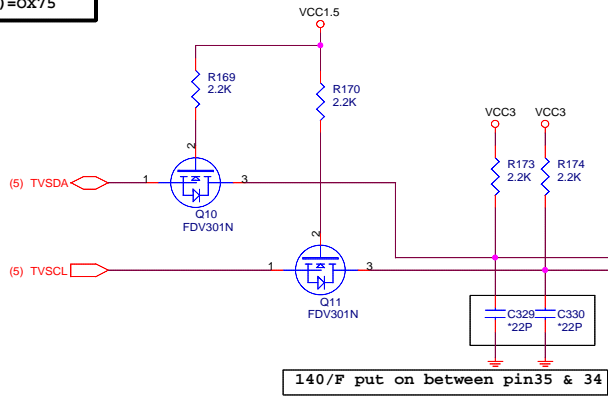

**QUANTA COMPUTER**

Title: **CRT & TV DECODER**

Size: Custom Document Number: **RB1 Main Board** Rev: 1A

Date: 星期二, 九月 02, 2003 Sheet: 9 of 28

# ICH HUB

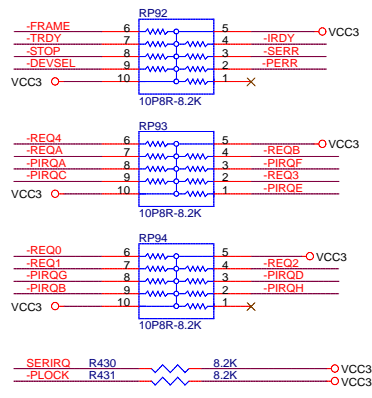

REQ0: CARD/1394/MS AD25  
 REQ1: MINI PCI AD20  
 REQ2: LAN AD29  
 REQ3: X

-PIROA: LAN  
 -PIROB: CARDBUS/1394  
 -PIROC: CARDBUS/1394  
 -PIROD: MINIPCI  
 -PIROE: CARDBUS/1394  
 -PIROF: MINI-PCI  
 -PIROG: CARDBUS/1394  
 -PIROH: Internal USB

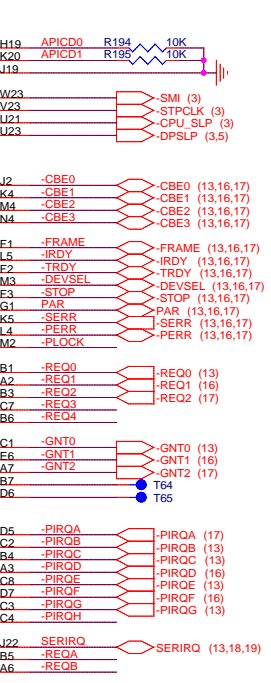
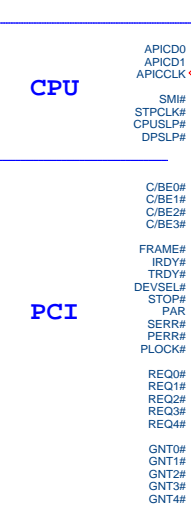
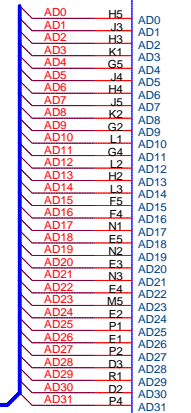
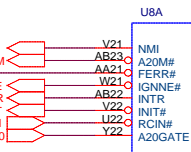
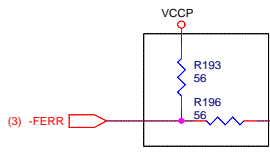
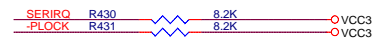

## CD-ROM CONNECTOR

### CON5 OPTICAL CONNECTOR

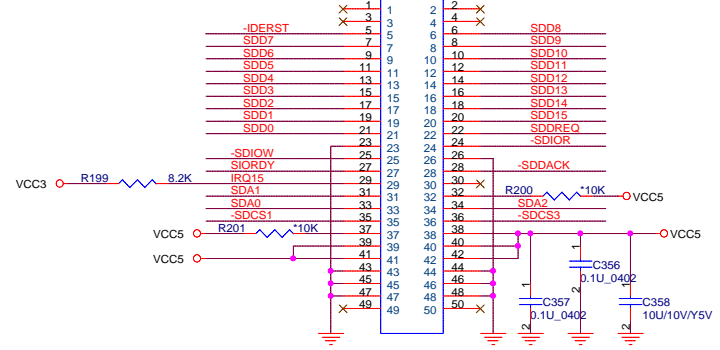

## HDD CONNECTOR

### CON6

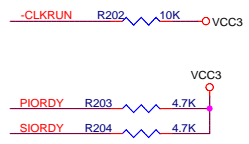
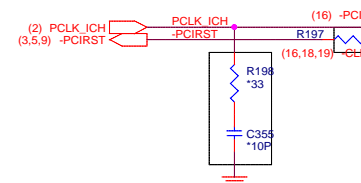
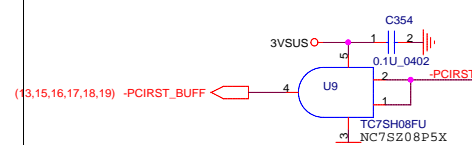
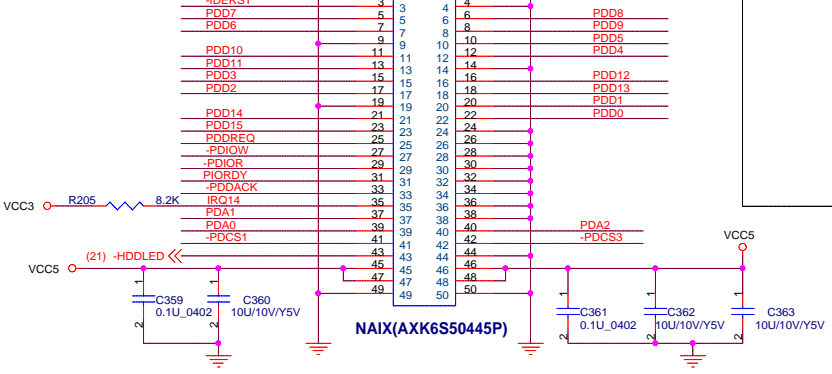

## IDE

### IDE



Title		Rev	
ICH4-M		1A	
Size	Document Number	Rev	
Custom		RB1 Main Board	
Date: 星期二, 九月 02, 2003		Sheet	10 of 28

# ICH4-M

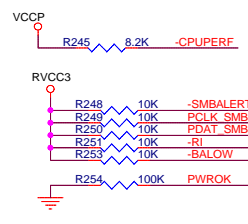
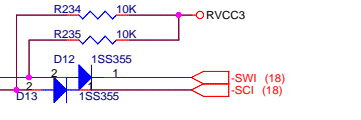
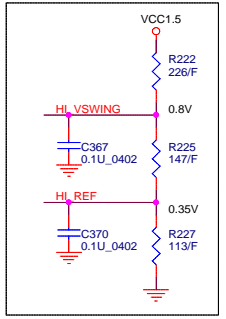
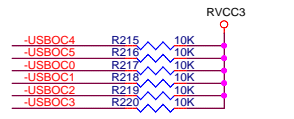
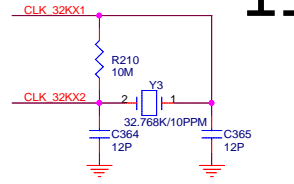
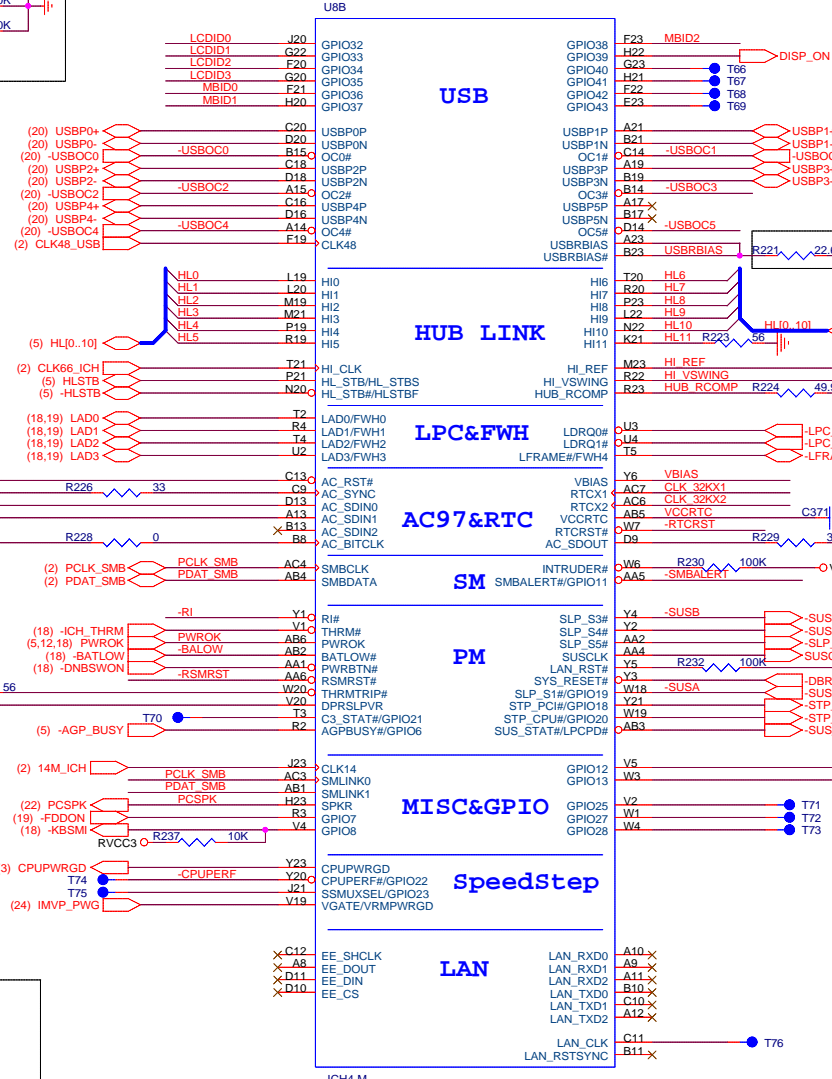
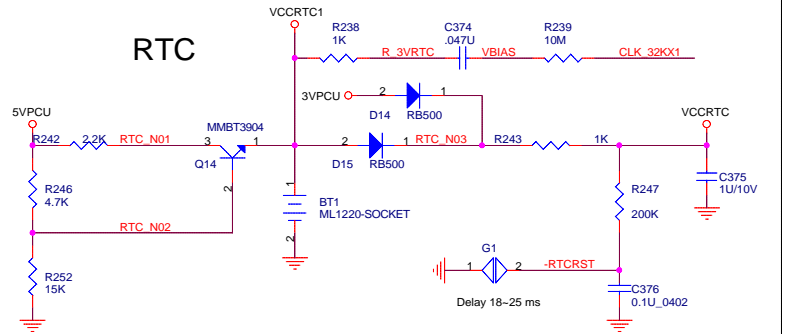
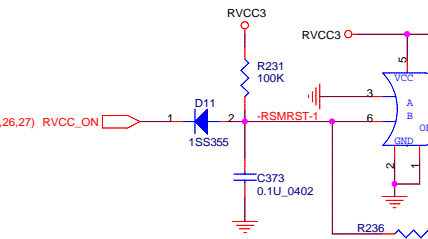
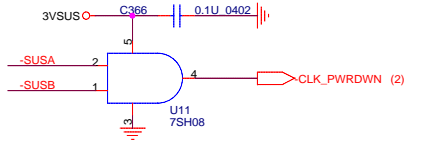
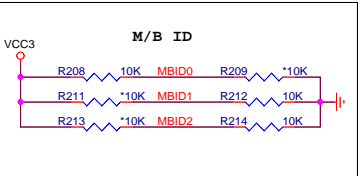
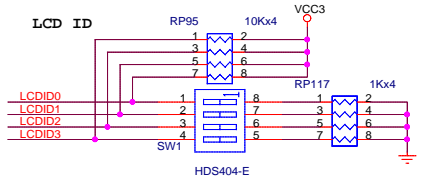

**QUANTA COMPUTER**

Title: **ICH4-M USB,HUB & LPC INTERFACE**

Size: Custom Document Number: **RB1 Main Board** Rev: 1A

Date: 星期二, 九月 02, 2003 Sheet: 11 of 28

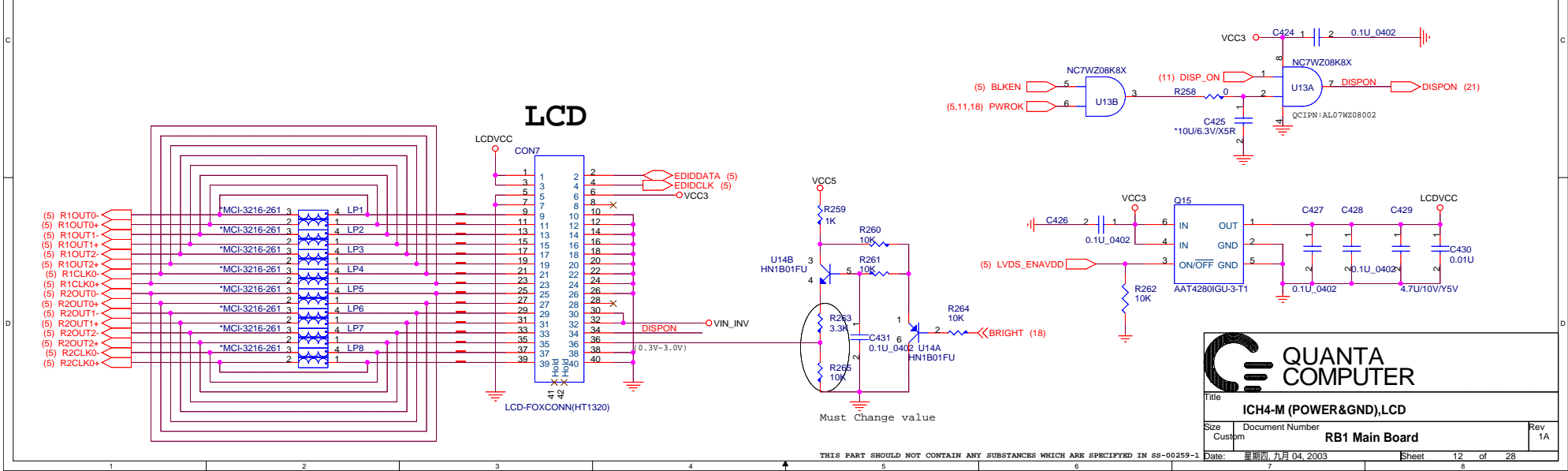
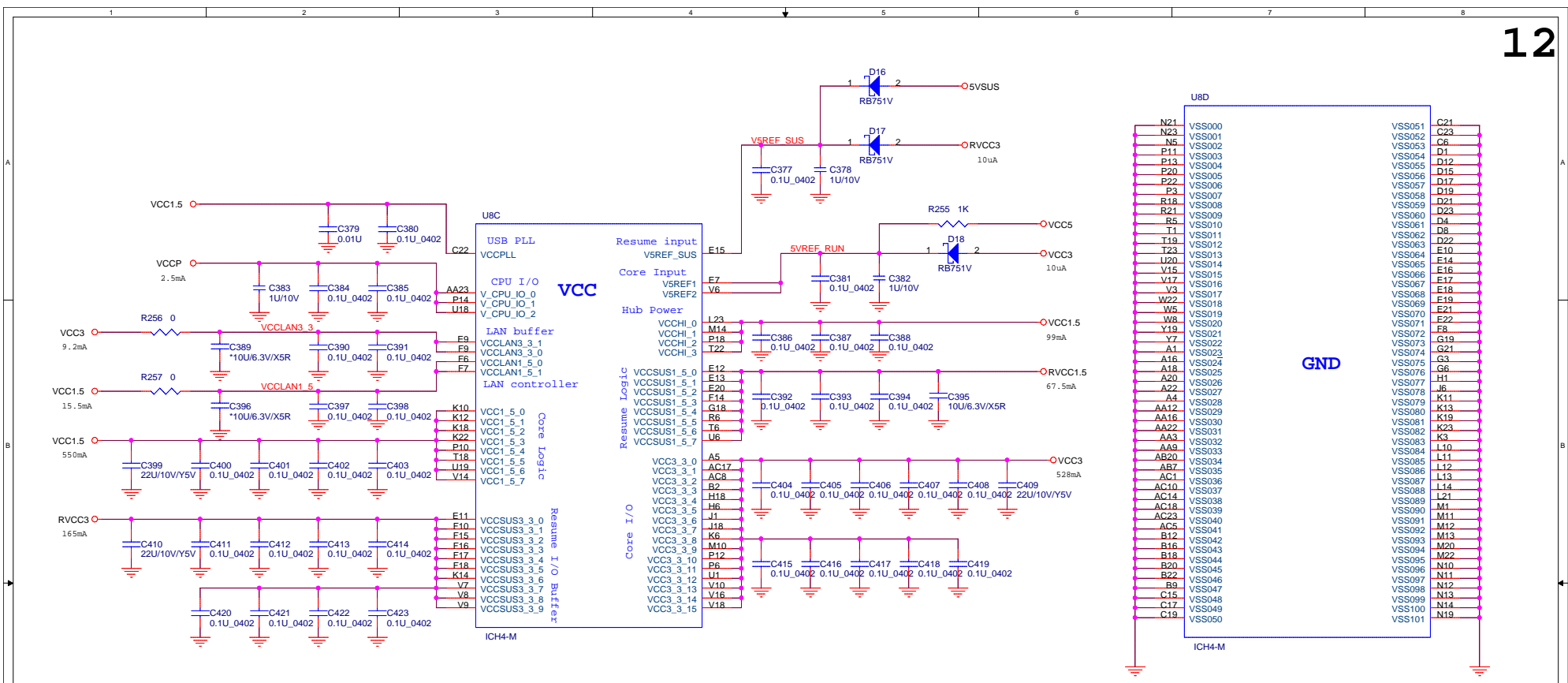

**QUANTA COMPUTER**

Title: **ICH4-M (POWER&GND),LCD**

Size: Custom Document Number: **RB1 Main Board** Rev: 1A

Date: 2003.04.04 Sheet: 12 of 28



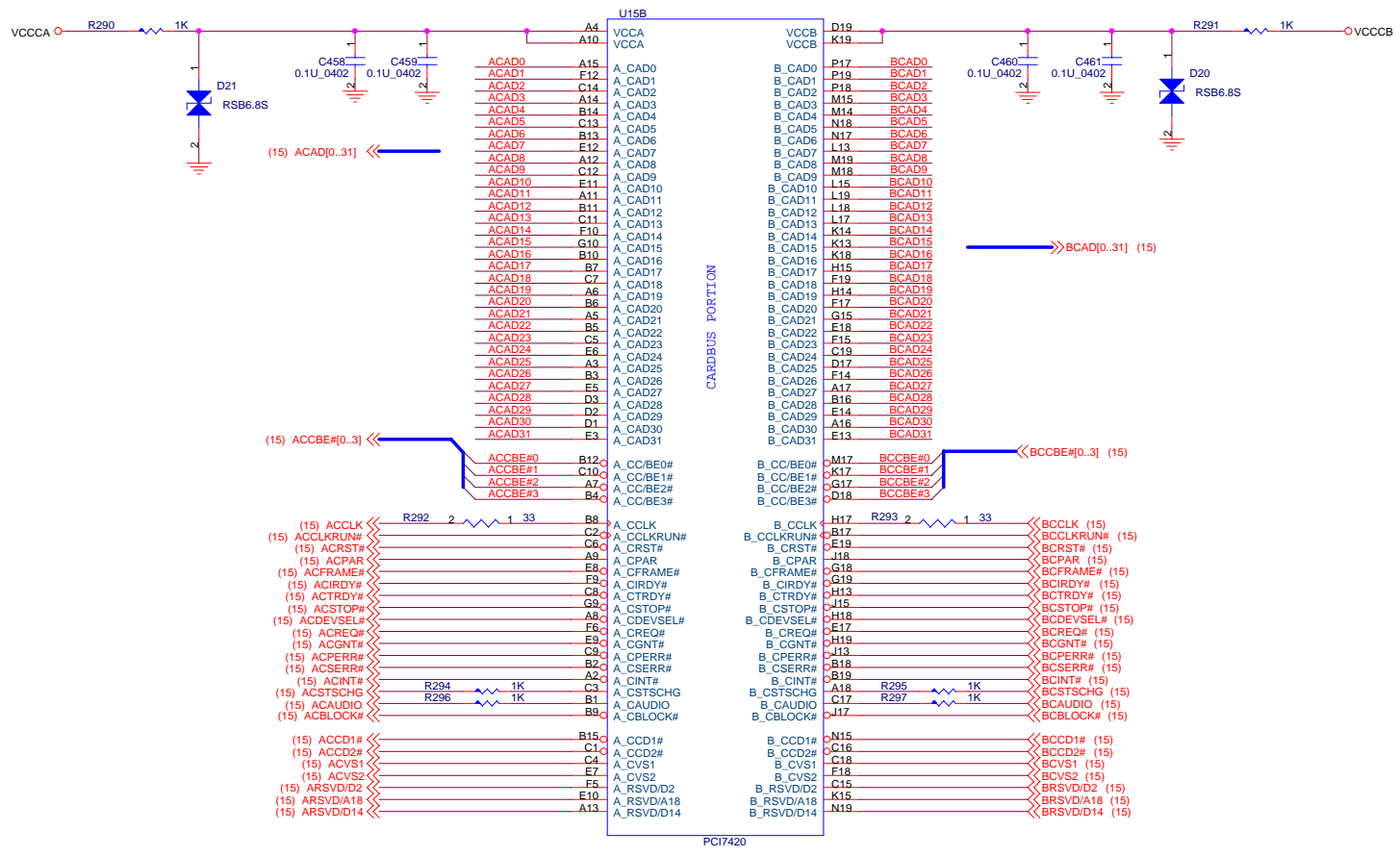

Title <b>TI-PCI7420 CardBus Control -- B</b>			Rev 1A
Size Custom	Document Number <b>RB1 Main Board</b>		
Date: 星期二, 九月 02, 2003	Sheet 14	of 28	

THIS PART SHOULD NOT CONTAIN ANY SUBSTANCES WHICH ARE SPECIFIED IN 66-00259-1

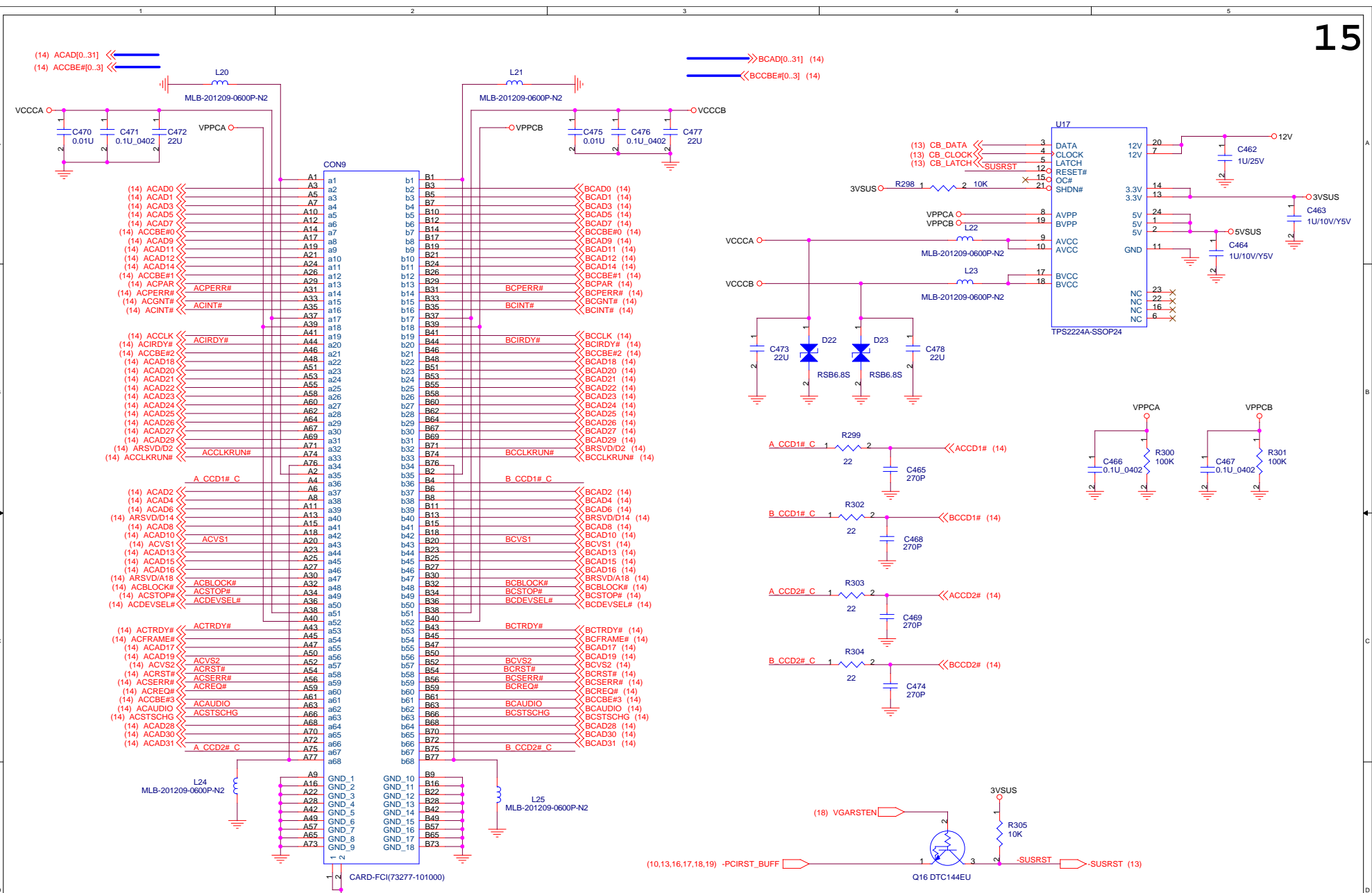

**QUANTA COMPUTER**

Title: **CardBus Control SLOT**

Size: Custom	Document Number: <b>RB1 Main Board</b>	Rev: 1A
--------------	--	---------

Date: 星期二, 九月 02, 2003 Sheet 15 of 28

ID Select : AD20  
 Interrupt Pin : -PIRQD, -PIRQF  
 Request indicates : -REQ1  
 Grant indicates : -GNT1

LED\_GP :LED WLEN LINK  
 Output Current : 7mA  
 Blink rate : 1 flash per every 3 sec.

WLSW:  
 Low : disable the radio.  
 High : Enable the radio.

MINIPCI-AMP(440073-124)

CON10

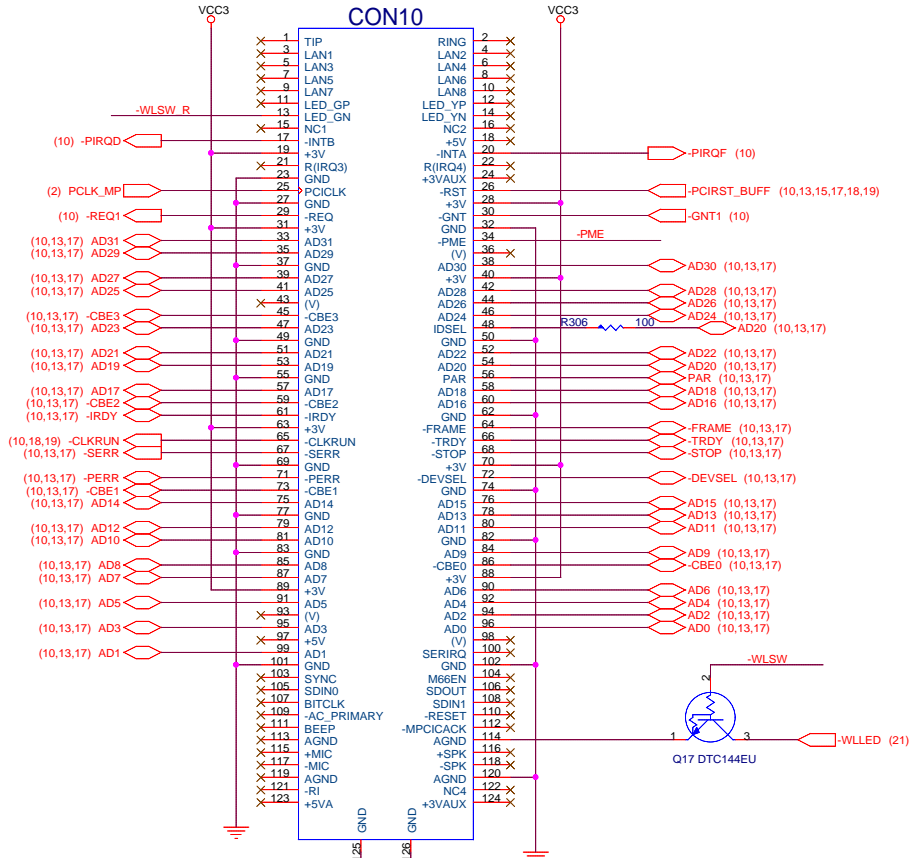

MDC

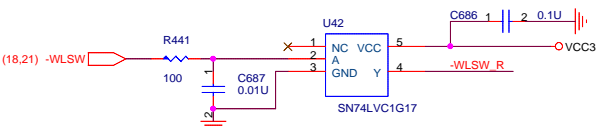
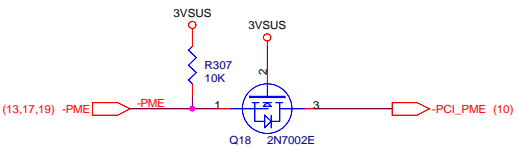
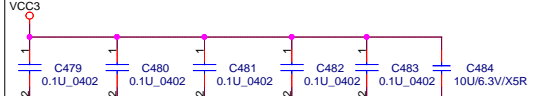
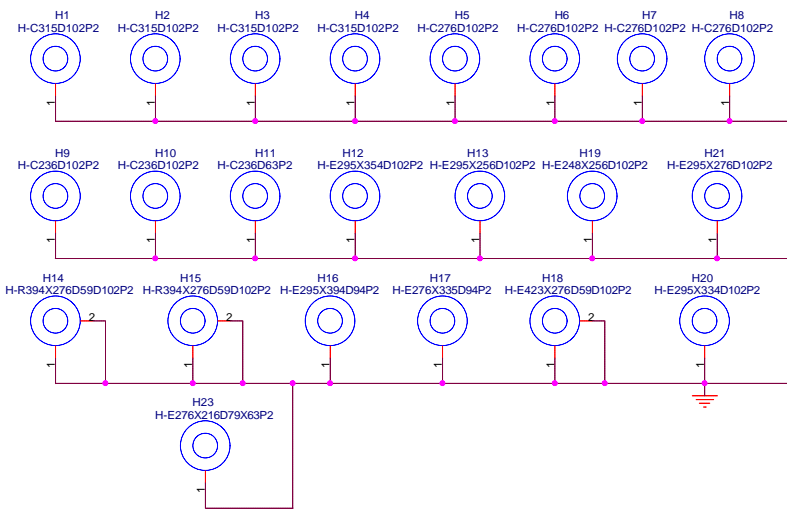
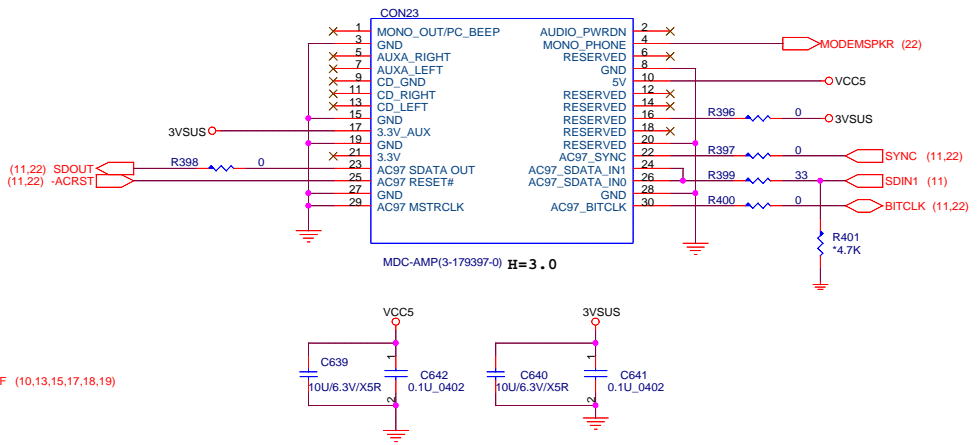

**QUANTA COMPUTER**

Title: MINIPCI /MDC  
 Size: Custom  
 Document Number: RB1 Main Board  
 Date: 星期五, 九月 05, 2003  
 Sheet: 16 of 28  
 Rev: 1A



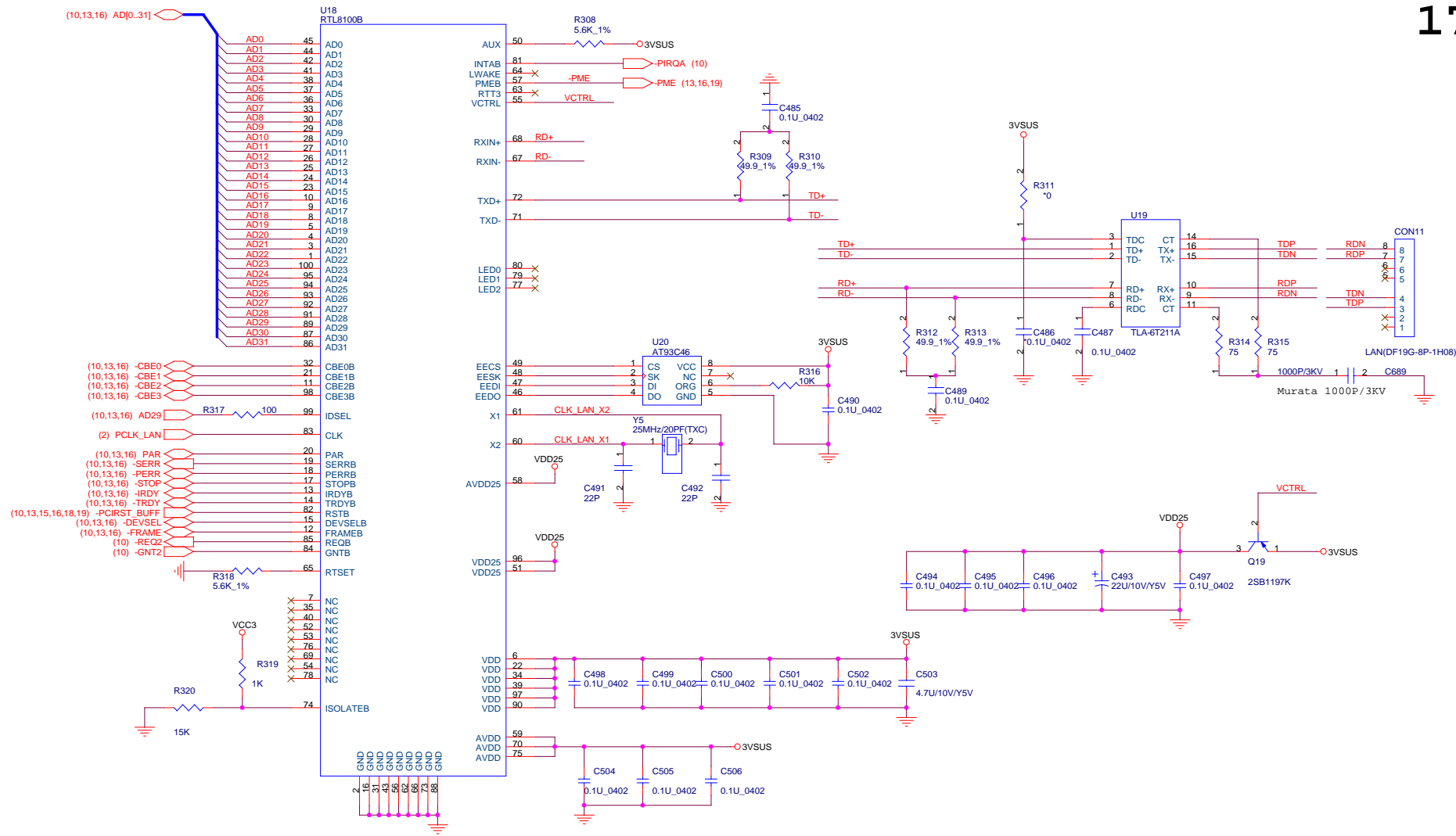

Title			Rev
RTL8100B PCI LAN			1A
Size	Document Number		
Custom	JE1.1 Main Board		
Date: 星期五, 九月 05, 2003		Sheet	17 of 28



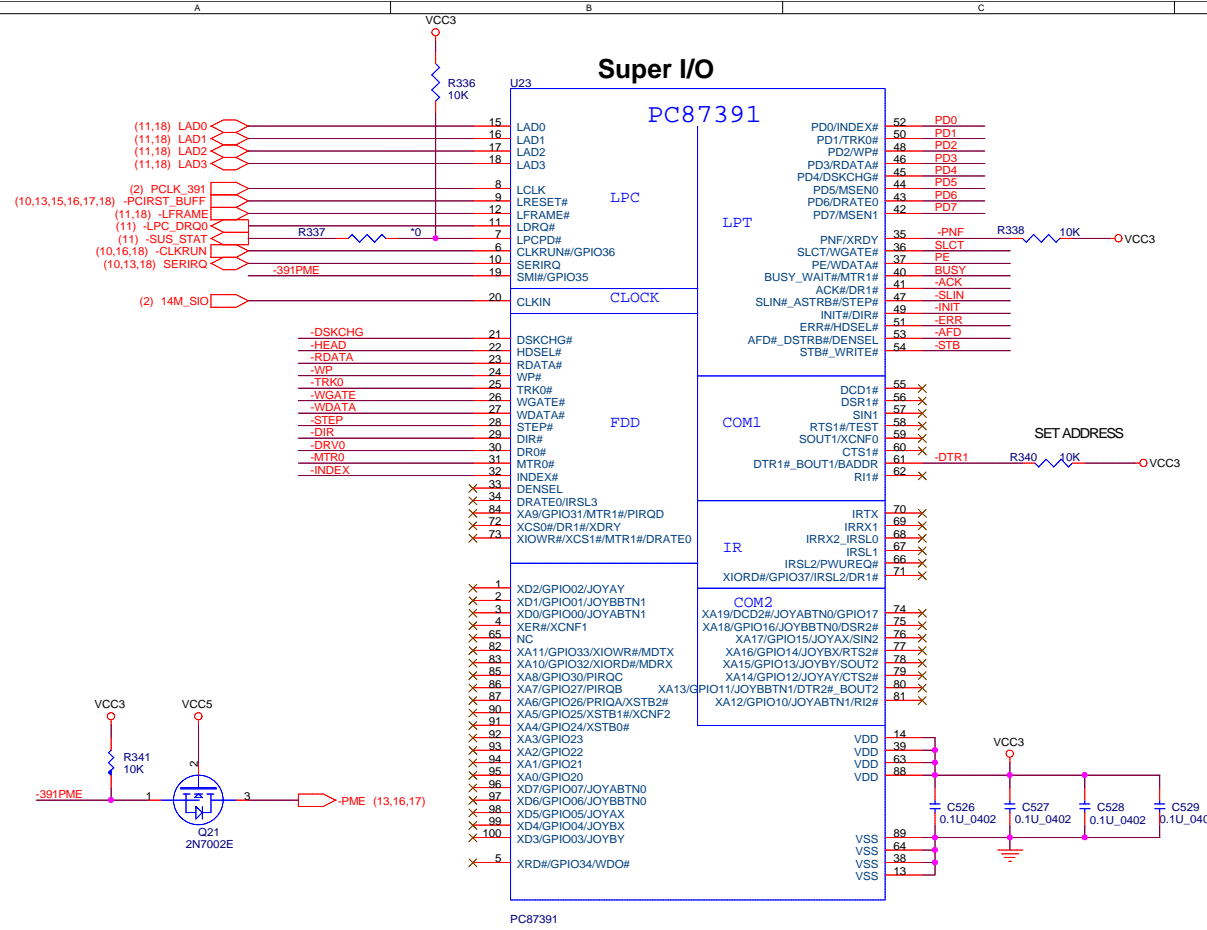

DRAM Thermal

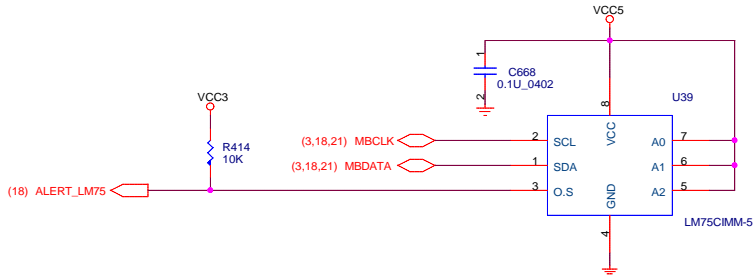

USB Option

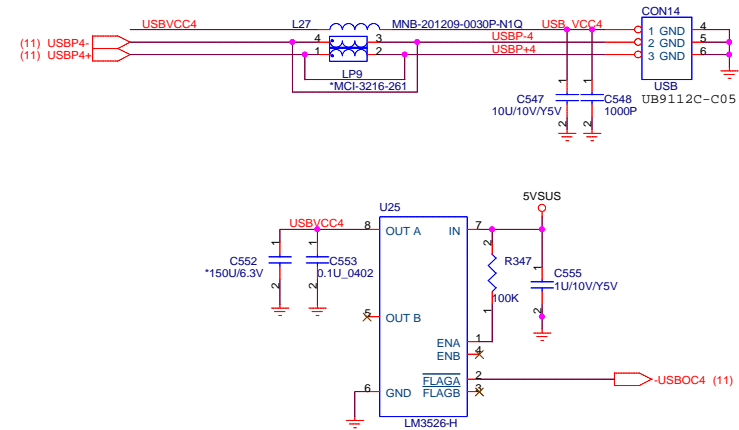
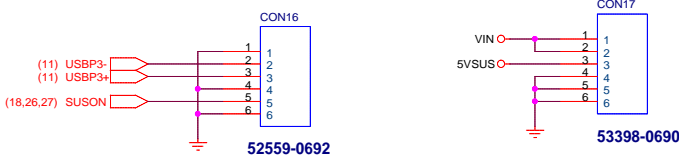

KEYBOARD

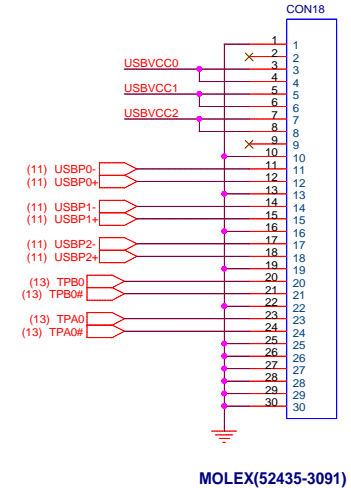
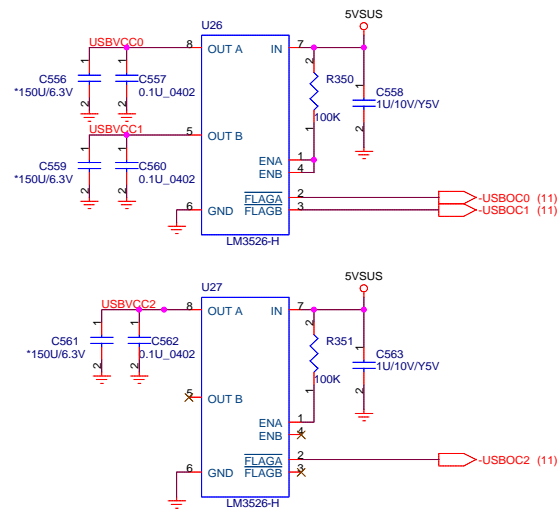
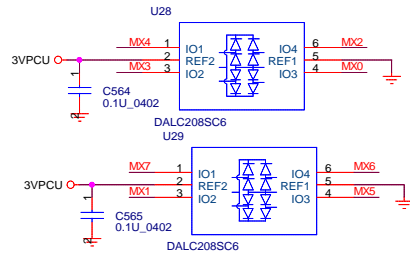
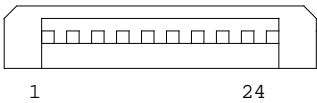
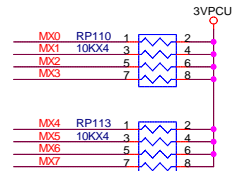
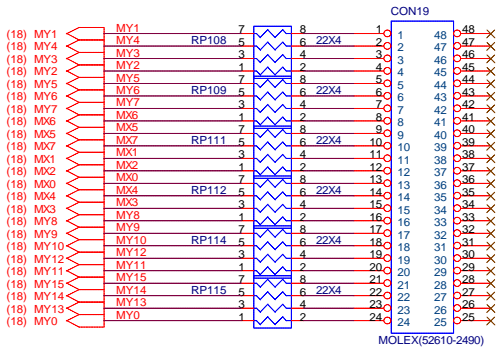

Title		K/B ,USB	
Size	Document Number	Rev	
Custom	RB1 Main Board	1A	
Date:	星期二, 九月 02, 2003	Sheet	20 of 28

POWER SWITCH /LED BOARD CONNECTOR(SWX-163)

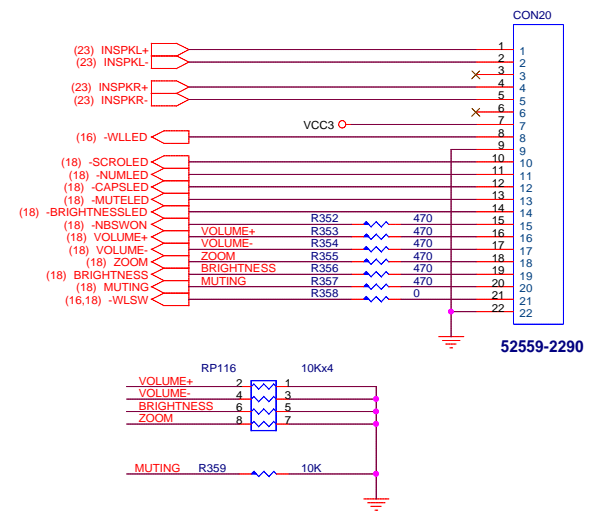

LED BOARD CONNECTOR(LEX-55)

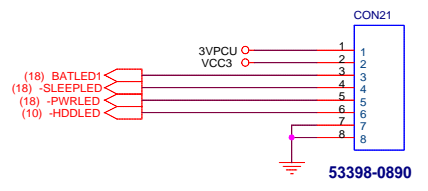

CHARGER BOARD CONNECTOR(PWS-37)

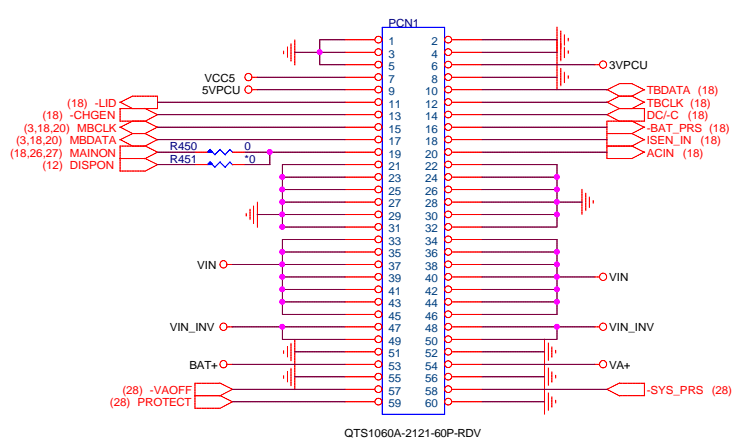

MAIN FAN UNIT

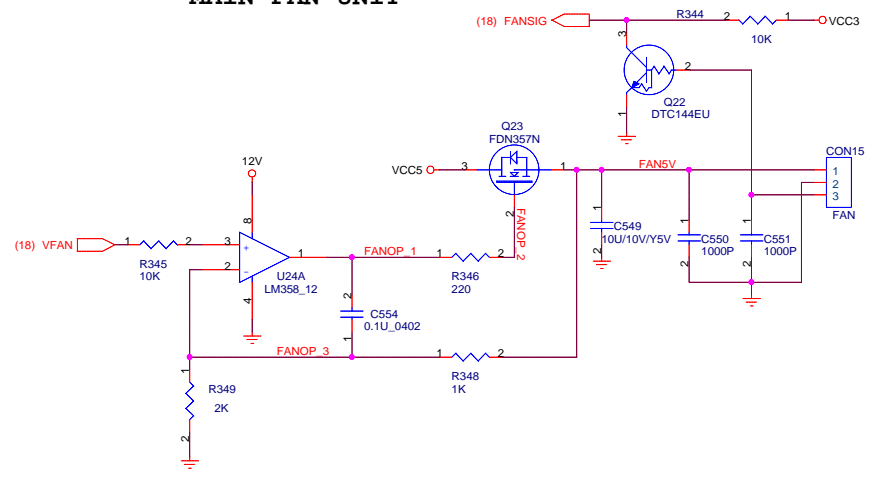

2ND FAN UNIT

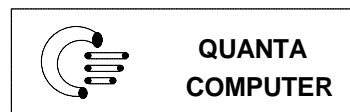
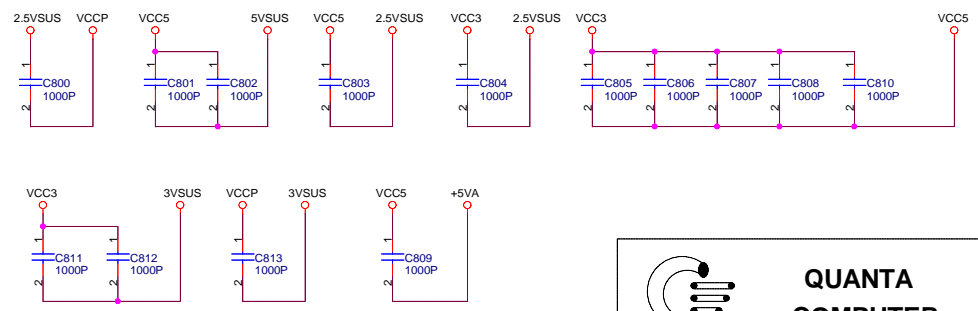
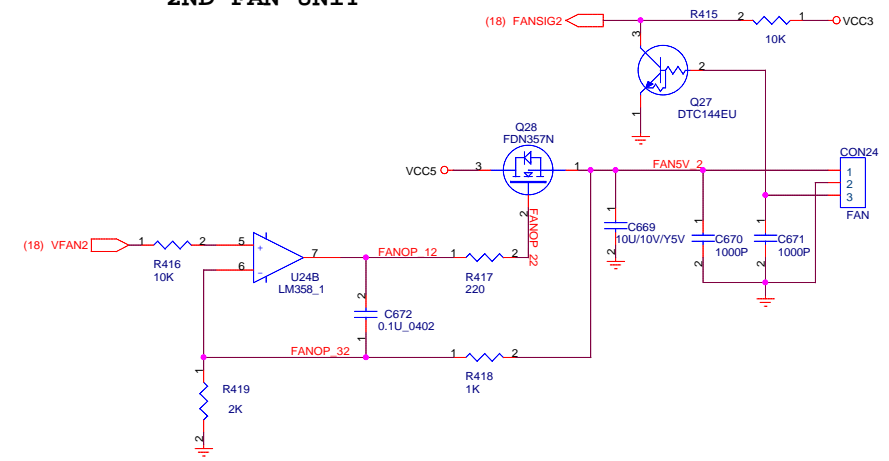

Size	Document Number	Rev
	LED,P/S,C/B CONNECTOR	1A

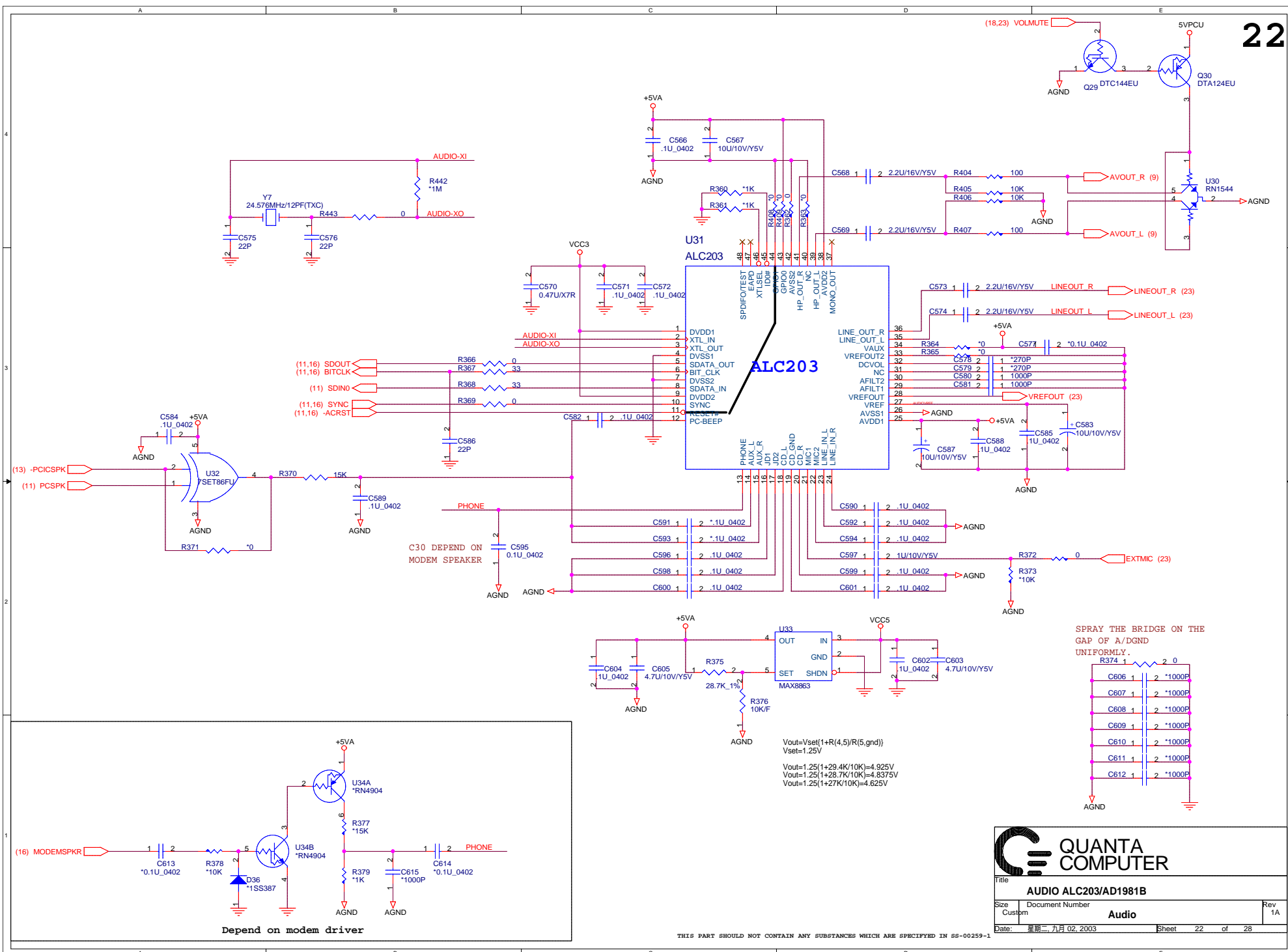

C30 DEPEND ON MODEM SPEAKER

Depend on modem driver

$$V_{out} = V_{set} \left( 1 + R(4,5) / R(5, \text{gnd}) \right)$$

$$V_{set} = 1.25V$$

$$V_{out} = 1.25 \left( 1 + 29.4K / 10K \right) = 4.925V$$

$$V_{out} = 1.25 \left( 1 + 28.7K / 10K \right) = 4.8375V$$

$$V_{out} = 1.25 \left( 1 + 27K / 10K \right) = 4.625V$$

SPRAY THE BRIDGE ON THE GAP OF A/DGND UNIFORMLY.



# QUANTA COMPUTER

Title		
<b>AUDIO ALC203/AD1981B</b>		
Size	Document Number	Rev
Custom	<b>Audio</b>	1A
Date:	日期: 星期二, 九月 02, 2003	Sheet 22 of 28

THIS PART SHOULD NOT CONTAIN ANY SUBSTANCES WHICH ARE SPECIFIED IN 66-00259-1

# Audio amplifier

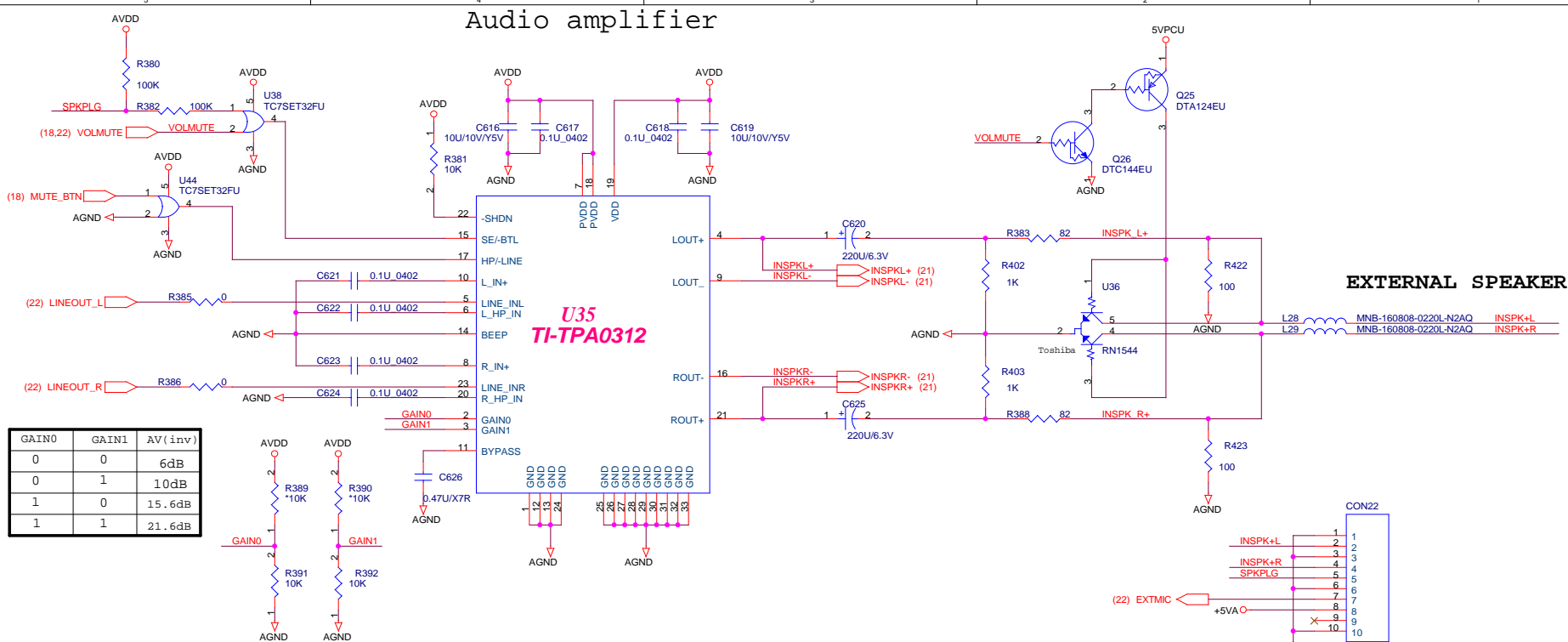

GAIN0	GAIN1	AV (inv)
0	0	6dB
0	1	10dB
1	0	15.6dB
1	1	21.6dB

## EXTERNAL SPEAKER

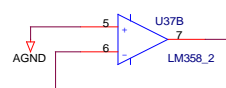
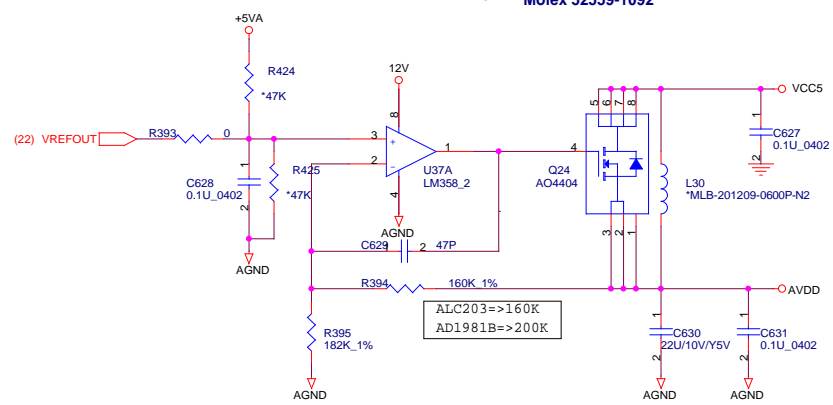

Title <b>AMP</b>		
Size Custom	Document Number <b>Audio</b>	Rev 1A
Date: 星期三, 九月 03, 2003	Sheet 23	of 28

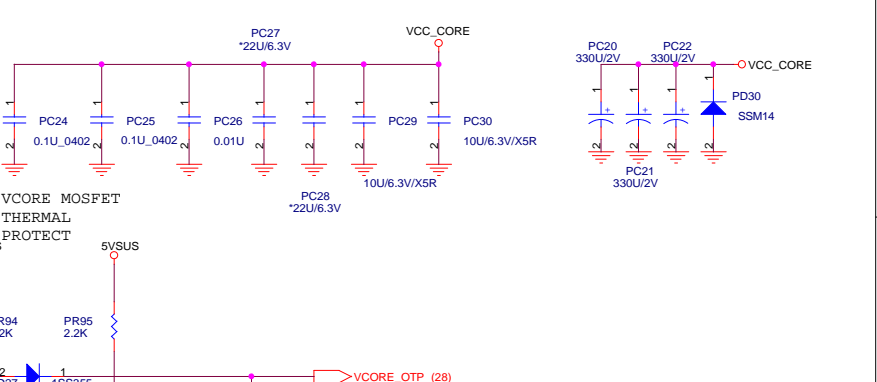
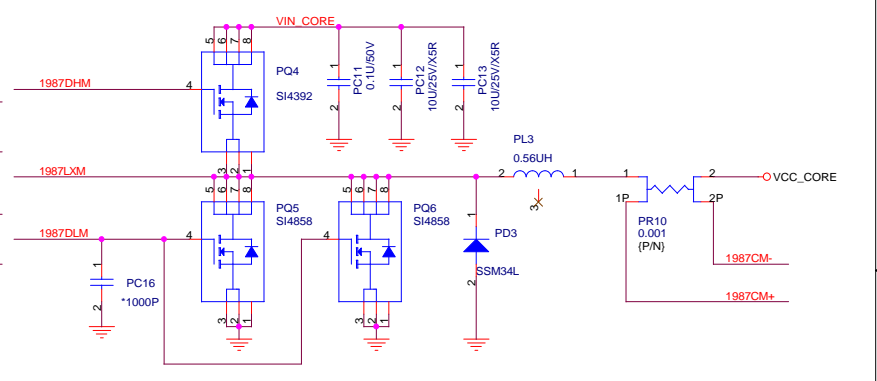
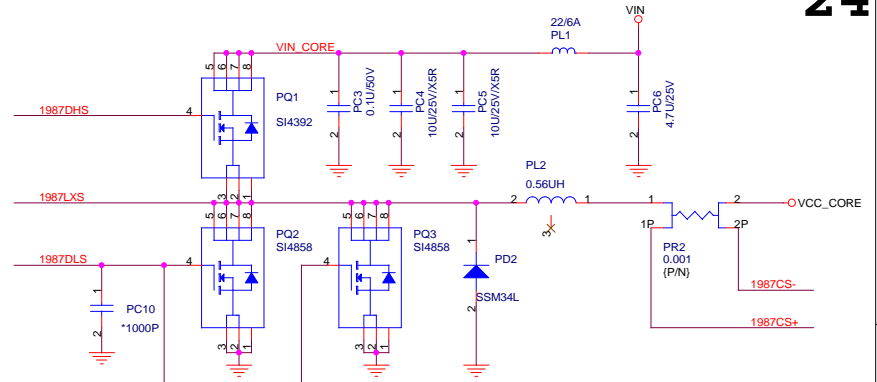
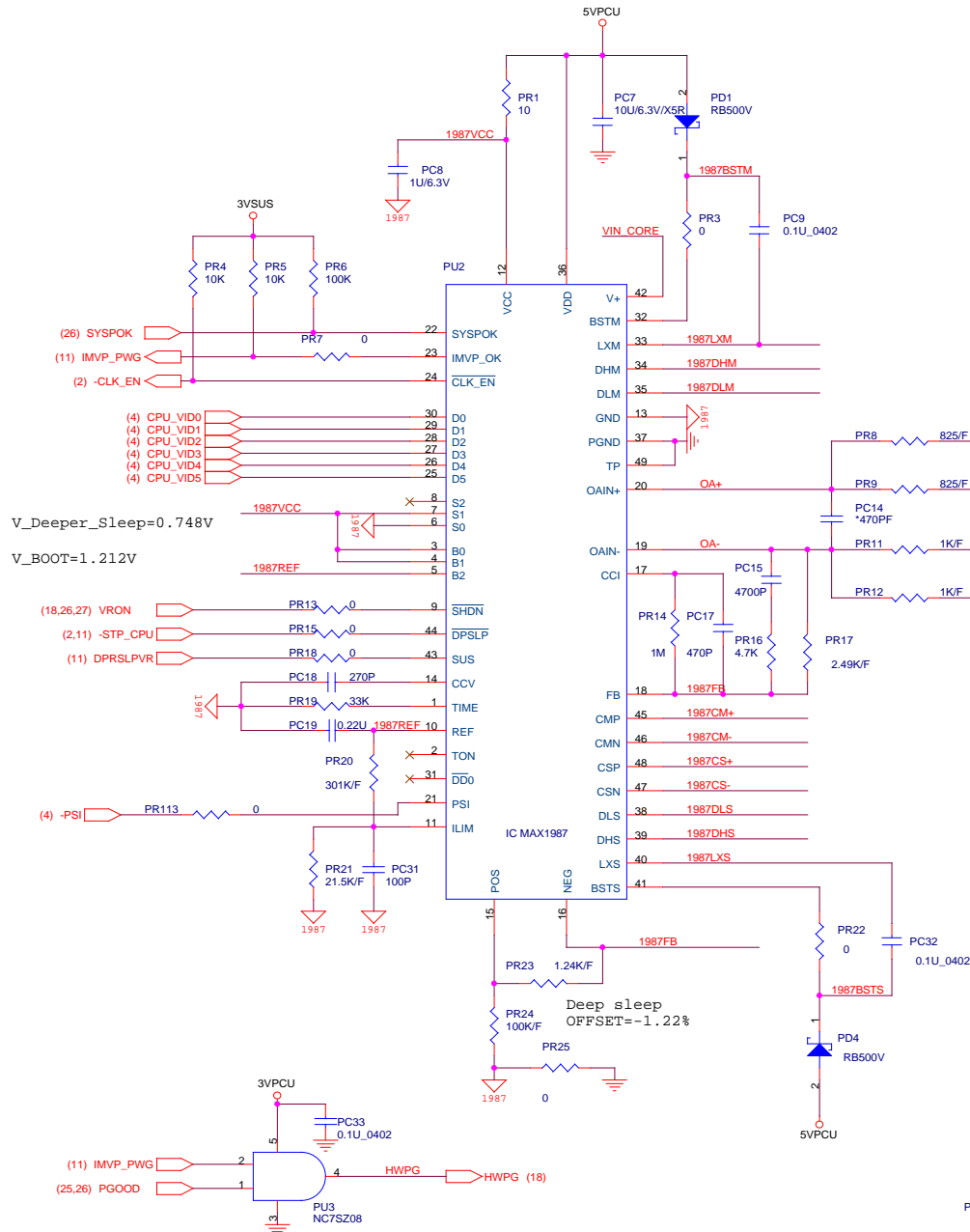

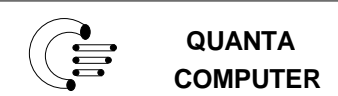

(1) IMVP\_PWG (25,26) PGOOD (1) HWPG (18)



Size Custom	Document Number RB1 Main Board	Rev 1A
Date: 星期三, 九月 03, 2003	Sheet 24 of 28	

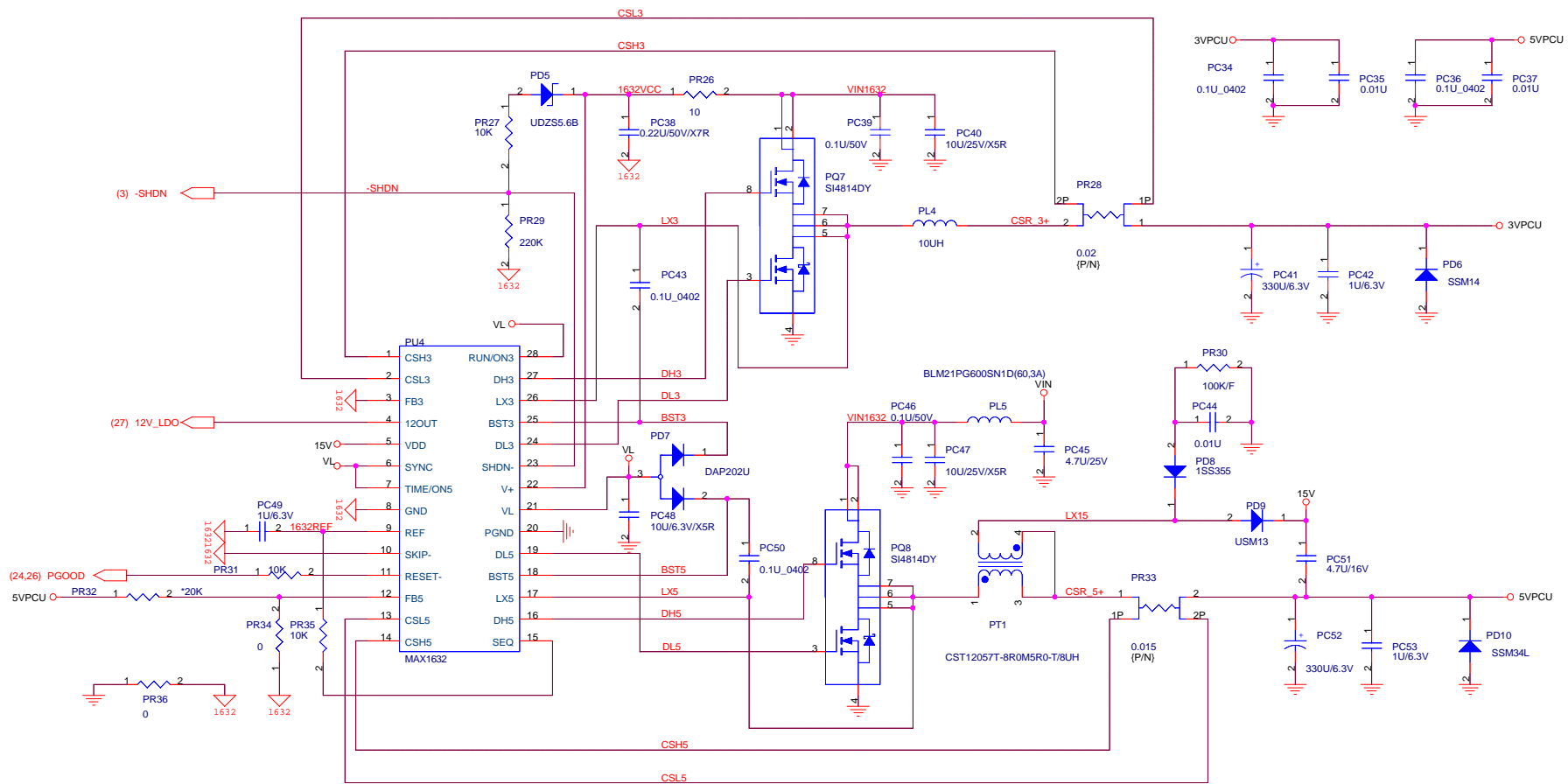





**QUANTA  
COMPUTER**

Size	Document Number	<b>RB1 Main Board</b>	Rev
			<b>1A</b>
Date: 星期二, 九月 02, 2003		Sheet 25 of 28	

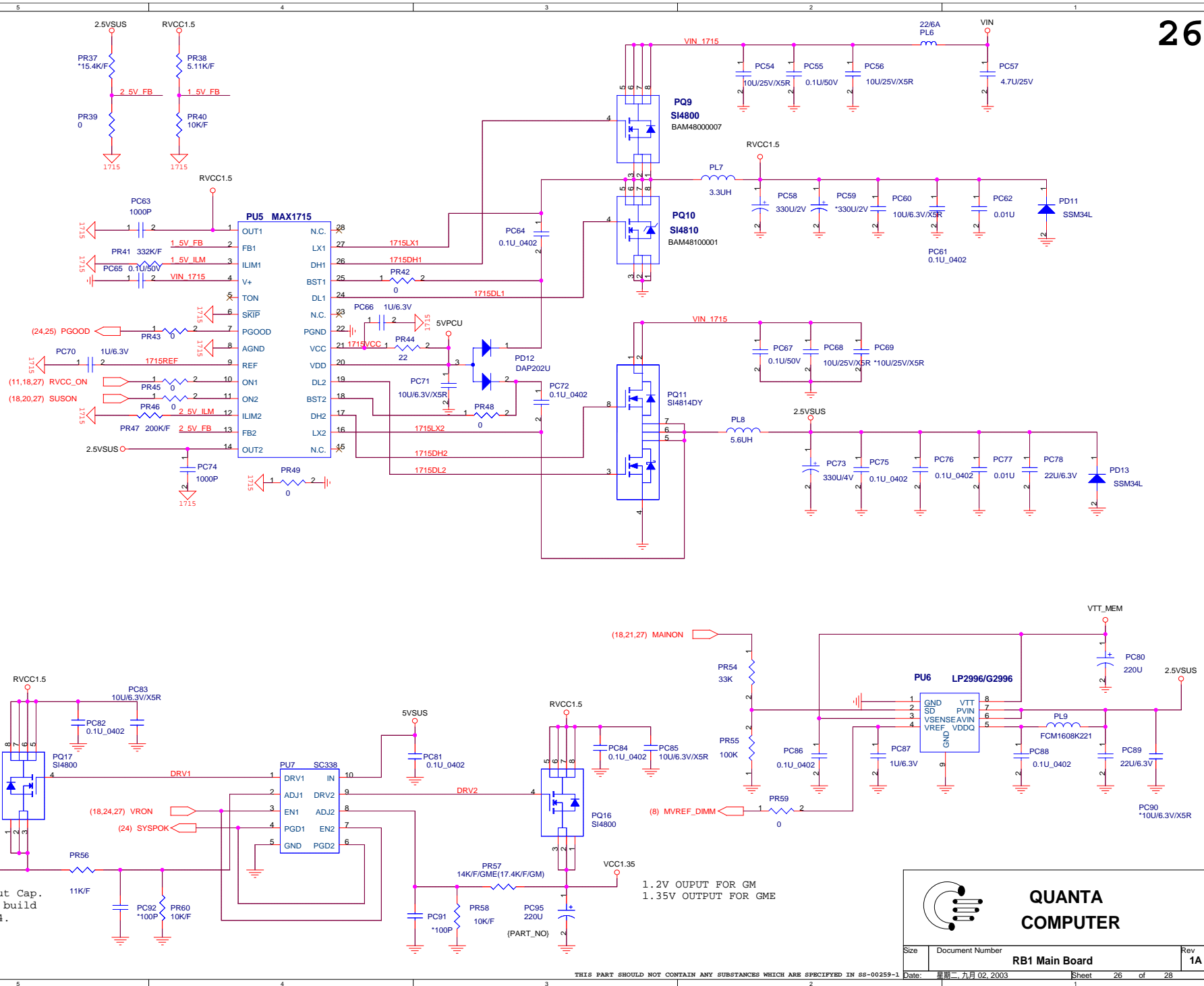

The output Cap. has been build on Page 4.

1.2V OUTPUT FOR GM  
1.35V OUTPUT FOR GME



**QUANTA  
COMPUTER**

Size	Document Number	Rev
	<b>RB1 Main Board</b>	<b>1A</b>

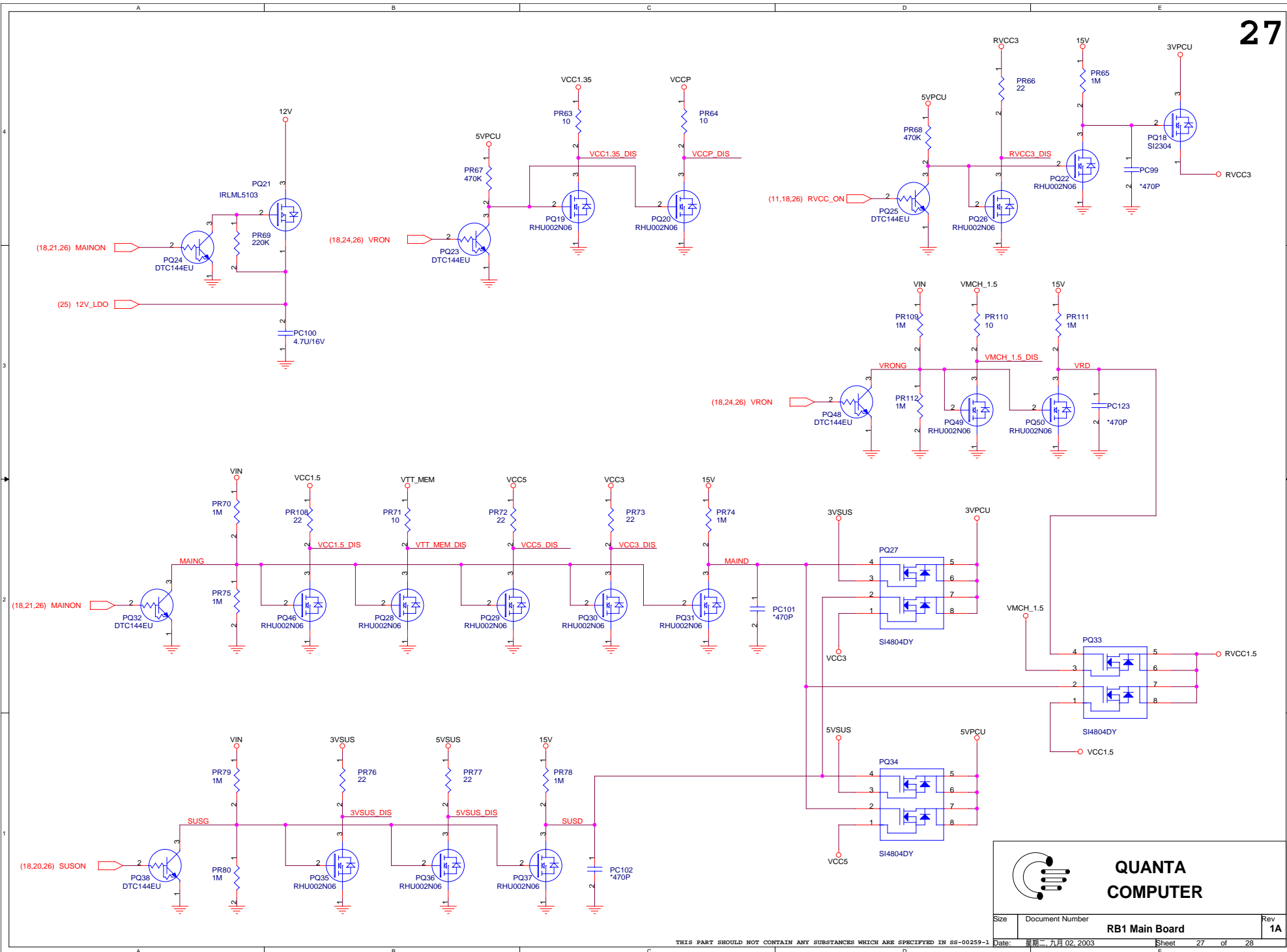



**QUANTA  
COMPUTER**

Size	Document Number	Rev
	<b>RB1 Main Board</b>	<b>1A</b>

Date: 星期二, 九月 02, 2003      Sheet 27 of 28

