

DESIGNER	J.CHEN	
CHECKED	Ogawa & OKU	
APPROVED	CHUJO	Part No. XXXXXX
CLASS	CHUJO	EC No. XXXXXX
<small>THIS DOCUMENT IS THE PROPERTY OF LENOVO. ITS USE IS AUTHORIZED ONLY FOR RESPONDING TO A REQUEST FOR QUOTATION OR FOR THE PERFORMANCE OF WORK FOR LENOVO. ALL QUESTIONS MUST BE REFERRED TO THE LENOVO PURCHASING DEPARTMENT.</small>		TITLE: Waiki_1.1 Ver. V3.04
LENOVO CONFIDENTIAL		BLOCK DIAGRAM
		sheet 1 of 100
		Wednesday, February 14, 2007

BLACK PAGE

DESIGNER	J.CHEN	
CHECKED	Ogawa & OKU	
APPROVED	CHUJO	Part No . XXXXXX
CLASS	CHUJO	EC No . XXXXXX
<small>THIS DOCUMENT IS THE PROPERTY OF LENOVO. ITS USE IS AUTHORIZED ONLY FOR RESPONDING TO A REQUEST FOR QUOTATION OR FOR THE PERFORMANCE OF WORK FOR LENOVO. ALL QUESTIONS MUST BE REFERRED TO THE LENOVO PURCHASING DEPARTMENT.</small>		TITLE: Waikiki_1.1 Ver. V3.04
LENOVO CONFIDENTIAL		EC HISTORY
		sheet 2 of 100 Wednesday, February 14, 2007

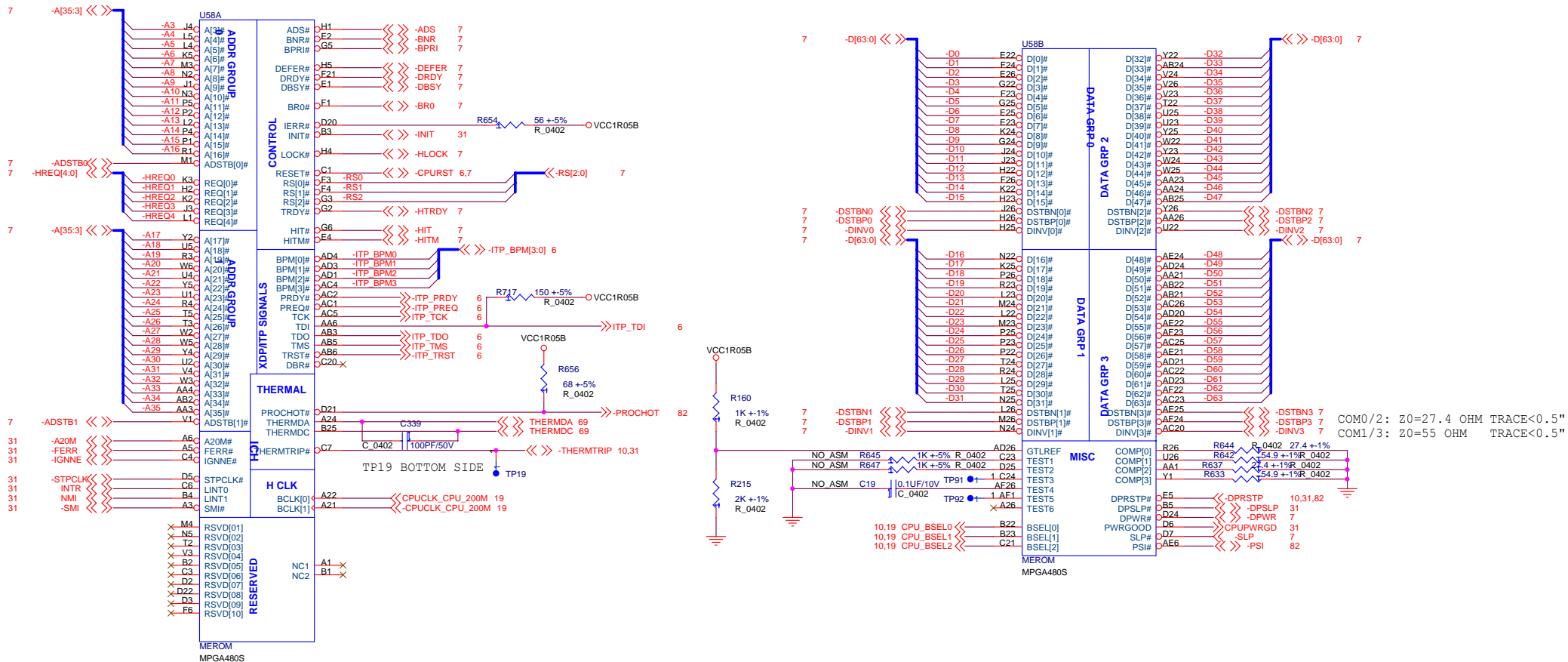

DESIGNER	J.CHEN	
CHECKED	Ogawa & OKU	
APPROVED	CHUJUO	Part No. XXXXXX
CLASS	CHUJUO	EC No. XXXXXX
<small>THIS DOCUMENT IS THE PROPERTY OF LENOVO. ITS USE IS AUTHORIZED ONLY FOR RESPONDING TO A REQUEST FOR QUOTATION OR FOR THE PERFORMANCE OF WORK FOR LENOVO. ALL QUESTIONS MUST BE REFERRED TO THE LENOVO PURCHASING DEPARTMENT.</small>		
TITLE: Waikiki_1.1 Ver. V3.04		
CPU MEROM-1 (HOST,BUS)		
sheet 3 of 100		
Wednesday, February 14, 2007		

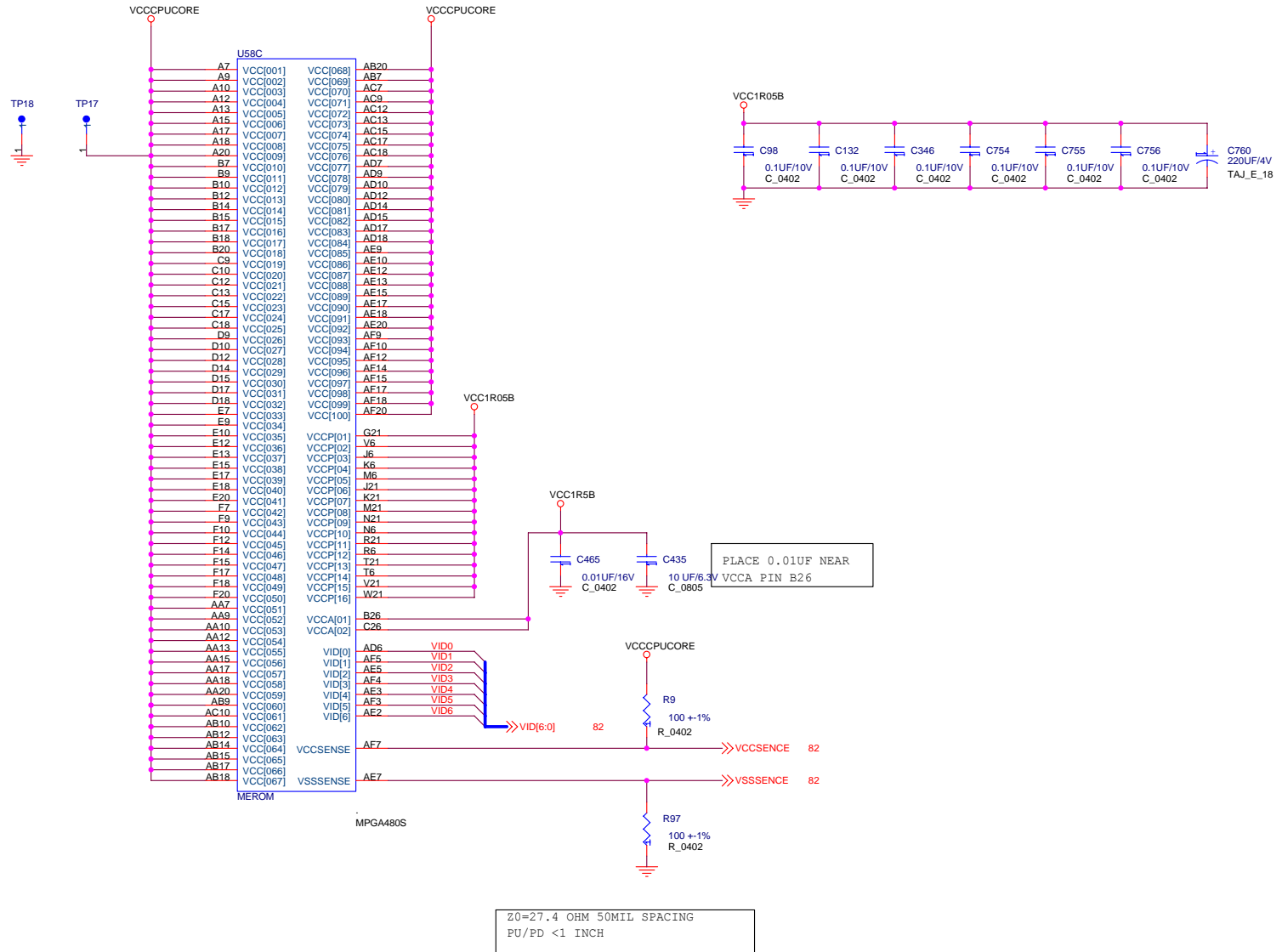

DESIGNER	J.CHEN	
CHECKED	Ogawa & OKU	
APPROVED	CHUJO	Part No. XXXXXX
CLASS	CHUJO	EC No. XXXXXX
<small>THIS DOCUMENT IS THE PROPERTY OF LENOVO. ITS USE IS AUTHORIZED ONLY FOR RESPONDING TO A REQUEST FOR QUOTATION OR FOR THE PERFORMANCE OF WORK FOR LENOVO. ALL QUESTIONS MUST BE REFERRED TO THE LENOVO PURCHASING DEPARTMENT.</small>		TITLE: Waikiki_1.1 Ver. V3.04
LENOVO CONFIDENTIAL		CPU MEROM-2(POWER,GND)
		sheet 4 of 100 Wednesday, February 14, 2007

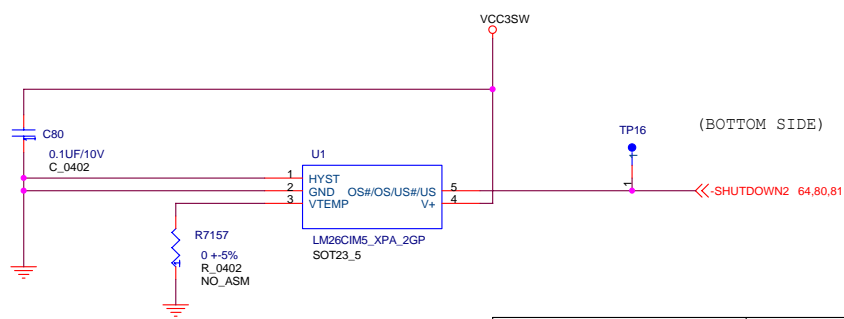
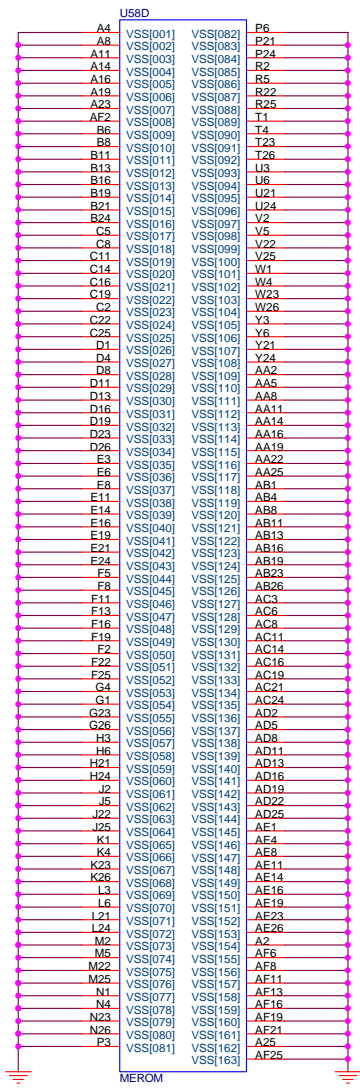

U1	R7157
NS LM26 MAXIM MAX6519	NOASM NOASM
MAXIM MAX6501 ADI ADT6501	ASM ASM

DESIGNER	J.CHEN	
CHECKED	Ogawa & OKU	
APPROVED	CHUJO	Part No. XXXXXX
CLASS	CHUJO	EC No. XXXXXX
THIS DOCUMENT IS THE PROPERTY OF LENOVO. ITS USE IS AUTHORIZED ONLY FOR RESPONDING TO A REQUEST FOR QUOTATION OR FOR THE PERFORMANCE OF WORK FOR LENOVO. ALL QUESTIONS MUST BE REFERRED TO THE LENOVO PURCHASING DEPARTMENT.		TITLE: Waikiki_1.1 Ver. V3.04
LENOVO CONFIDENTIAL		CPU-3
		sheet 5 of 100
		Wednesday, February 14, 2007

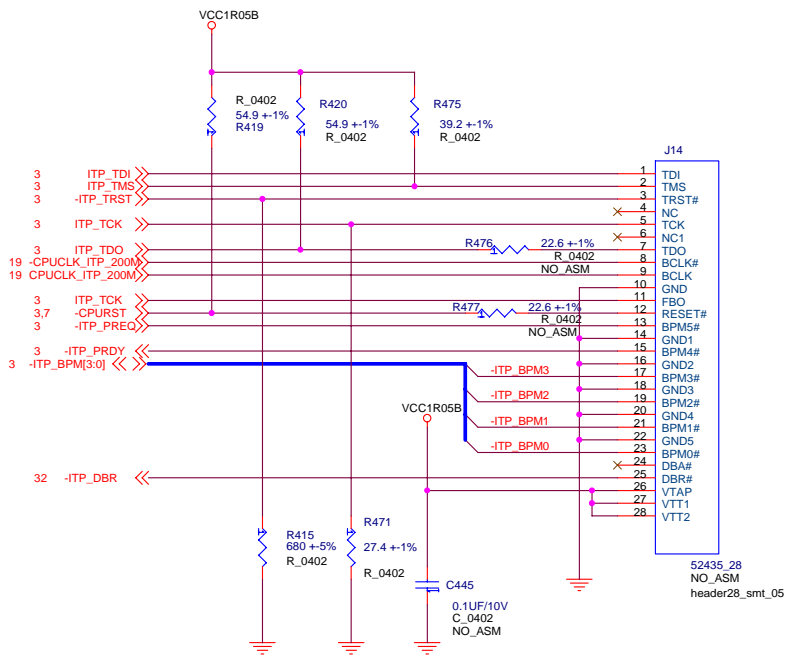

REF DES	FOR ITP700FLEX	FOR ITP-->XDP
J4	NO_ASM---->ASM	NO_ASM---->ASM
C445	ASM---->ASM	ASM---->ASM
R717	ASM(NO CHANGE)	ASM---->51 5% ASM
R476	ASM---->ASM	ASM---->ASM
R477	ASM---->ASM	ASM---->1K 5% ASM
R415	ASM(NO CHANGE)	ASM(NO CHANGE)
R419	ASM(NO CHANGE)	ASM-->NO_ASM
R420	ASM(NO CHANGE)	ASM(NO CHANGE)
R471	ASM(NO CHANGE)	ASM---->51 5% ASM
R475	ASM(NO CHANGE)	ASM---->51 5% ASM

NOTE: C445,R476 AND R477 "ASM" BEFORE SIT, "NO_ASM" FROM SIT.

(*1) TCK SIGNAL IS BRANCHED AT YONAH PIN
 (*2) -CPURST SIGNAL IS BRANCHED AT CRESTLINE PIN

DESIGNER	J.CHEN	
CHECKED	Ogawa & OKU	
APPROVED	CHUJO	Part No . XXXXXX
CLASS	CHUJO	EC No . XXXXXX
<small>THIS DOCUMENT IS THE PROPERTY OF LENOVO. ITS USE IS AUTHORIZED ONLY FOR RESPONDING TO A REQUEST FOR QUOTATION OR FOR THE PERFORMANCE OF WORK FOR LENOVO. ALL QUESTIONS MUST BE REFERRED TO THE LENOVO PURCHASING DEPARTMENT.</small>		TITLE: Waikiki_1.1 Ver. V3.04
LENOVO CONFIDENTIAL		ITP CONN
		sheet 6 of 100 Wednesday, February 14, 2007

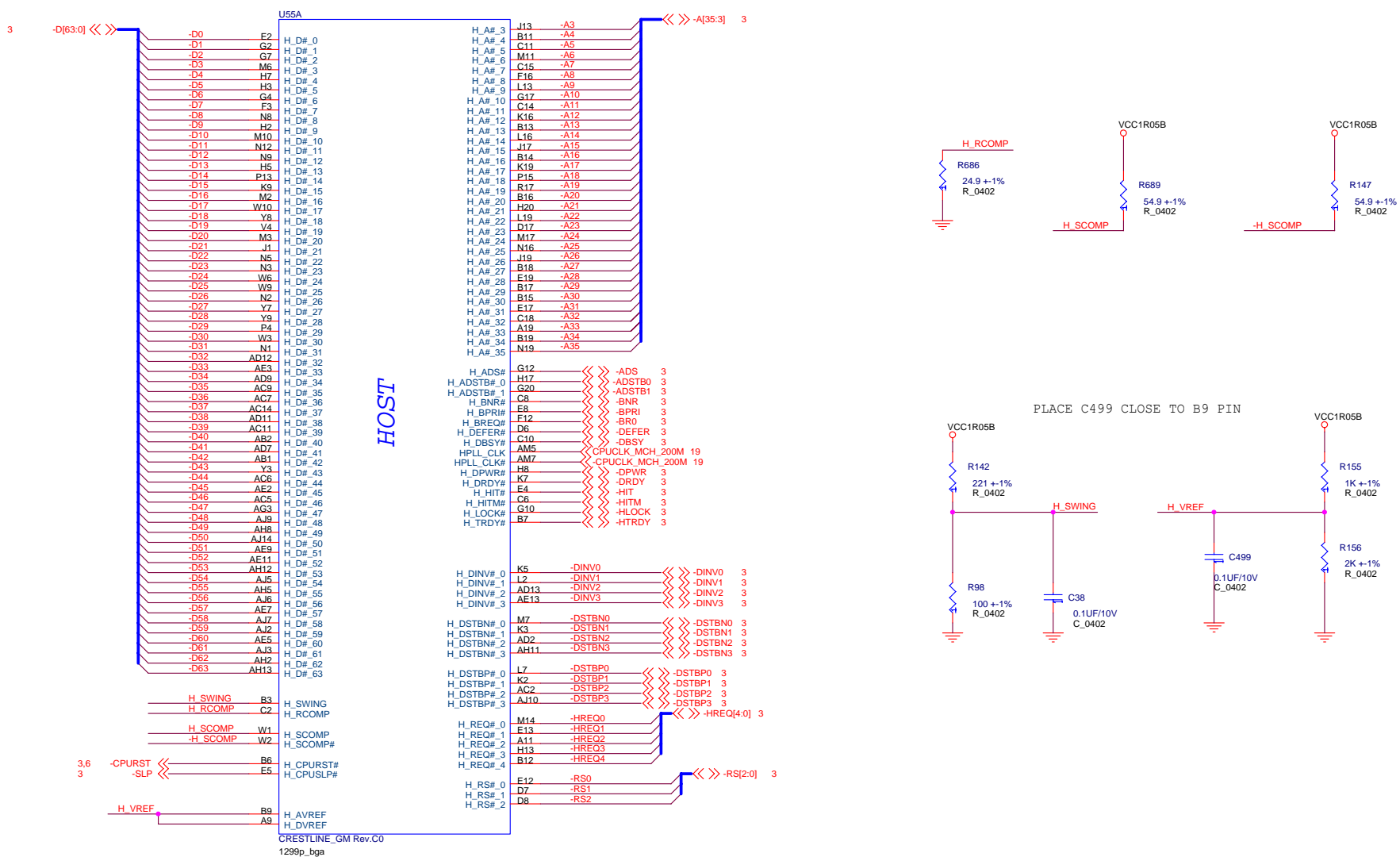

DESIGNER	J.CHEN	lenovo
CHECKED	Ogawa & OKU	
APPROVED	CHUJUO	Part No. XXXXXX
CLASS	CHUJUO	EC No. XXXXXX
<small>THIS DOCUMENT IS THE PROPERTY OF LENOVO. ITS USE IS AUTHORIZED ONLY FOR RESPONDING TO A REQUEST FOR QUOTATION OR FOR THE PERFORMANCE OF WORK FOR LENOVO. ALL QUESTIONS MUST BE REFERRED TO THE LENOVO PURCHASING DEPARTMENT.</small>		TITLE: Waikiki_1.1 Ver. V3.04
LENOVO CONFIDENTIAL		NB 965GM-1(HOST CFG)
		sheet 7 of 100 Wednesday, February 14, 2007

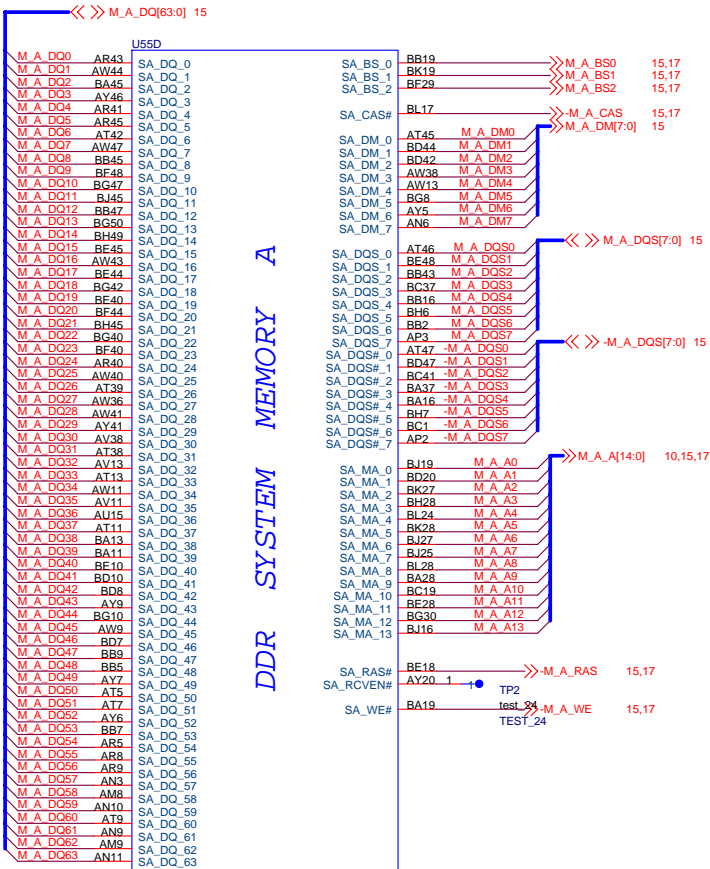

CRESTLINE_GM Rev.C0
1299p_bga

DESIGNER	J.CHEN	
CHECKED	Ogawa & OKU	
APPROVED	CHUJO	Part No . XXXXXX
CLASS	CHUJO	EC No . XXXXXX
<small>THIS DOCUMENT IS THE PROPERTY OF LENOVO. ITS USE IS AUTHORIZED ONLY FOR RESPONDING TO A REQUEST FOR QUOTATION OR FOR THE PERFORMANCE OF WORK FOR LENOVO. ALL QUESTIONS MUST BE REFERRED TO THE LENOVO PURCHASING DEPARTMENT.</small>		TITLE: Waiki_1.1 Ver. V3.04
LENOVO CONFIDENTIAL		965 DDR2-A
		sheet 8 of 100
		Wednesday, February 14, 2007

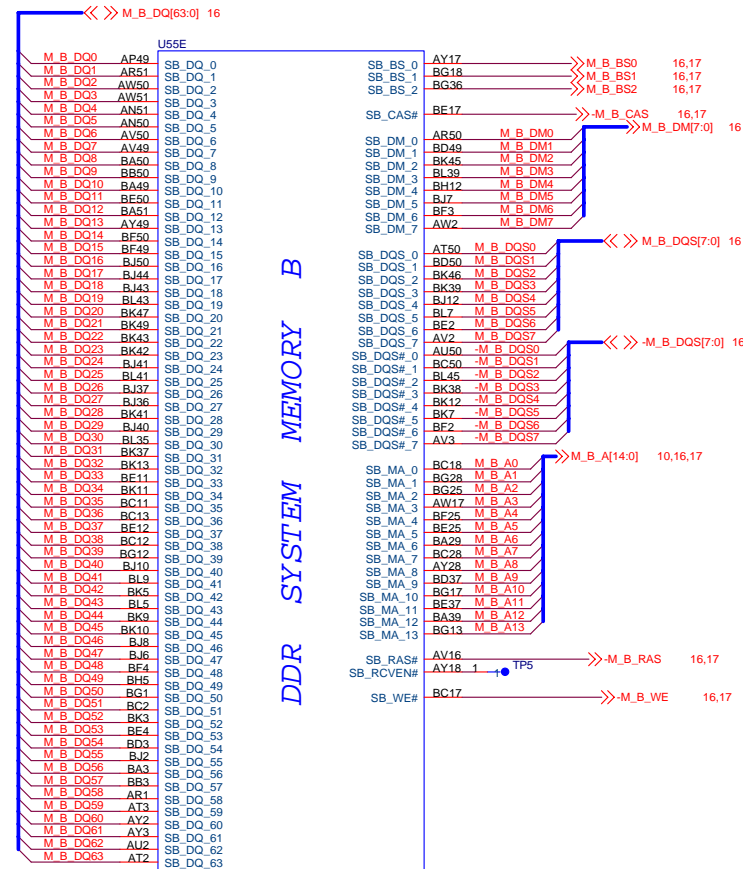

<<< M_B_DQ[63:0] 16

DDR SYSTEM MEMORY B

CRESTLINE_GM Rev.C0
1299p_bga

M_B_BS0 16,17
M_B_BS1 16,17
M_B_BS2 16,17

M_B_CAS# 16,17
M_B_DM[7:0] 16

M_B_DQS[7:0] 16

M_B_DQS[7:0] 16

M_B_A[14:0] 10,16,17

M_B_RAS# 16,17

M_B_WE# 16,17

DESIGNER	J.CHEN	
CHECKED	Ogawa & OKU	
APPROVED	CHUJO	Part No. XXXXXX
CLASS	CHUJO	EC No. XXXXXX
<small>THIS DOCUMENT IS THE PROPERTY OF LENOVO. ITS USE IS AUTHORIZED ONLY FOR RESPONDING TO A REQUEST FOR QUOTATION OR FOR THE PERFORMANCE OF WORK FOR LENOVO. ALL QUESTIONS MUST BE REFERRED TO THE LENOVO PURCHASING DEPARTMENT.</small>		TITLE: Waikiki_1.1 Ver. V3.04
LENOVO CONFIDENTIAL		NB 965 DDR2-B
		sheet 9 of 100
		Wednesday, February 14, 2007

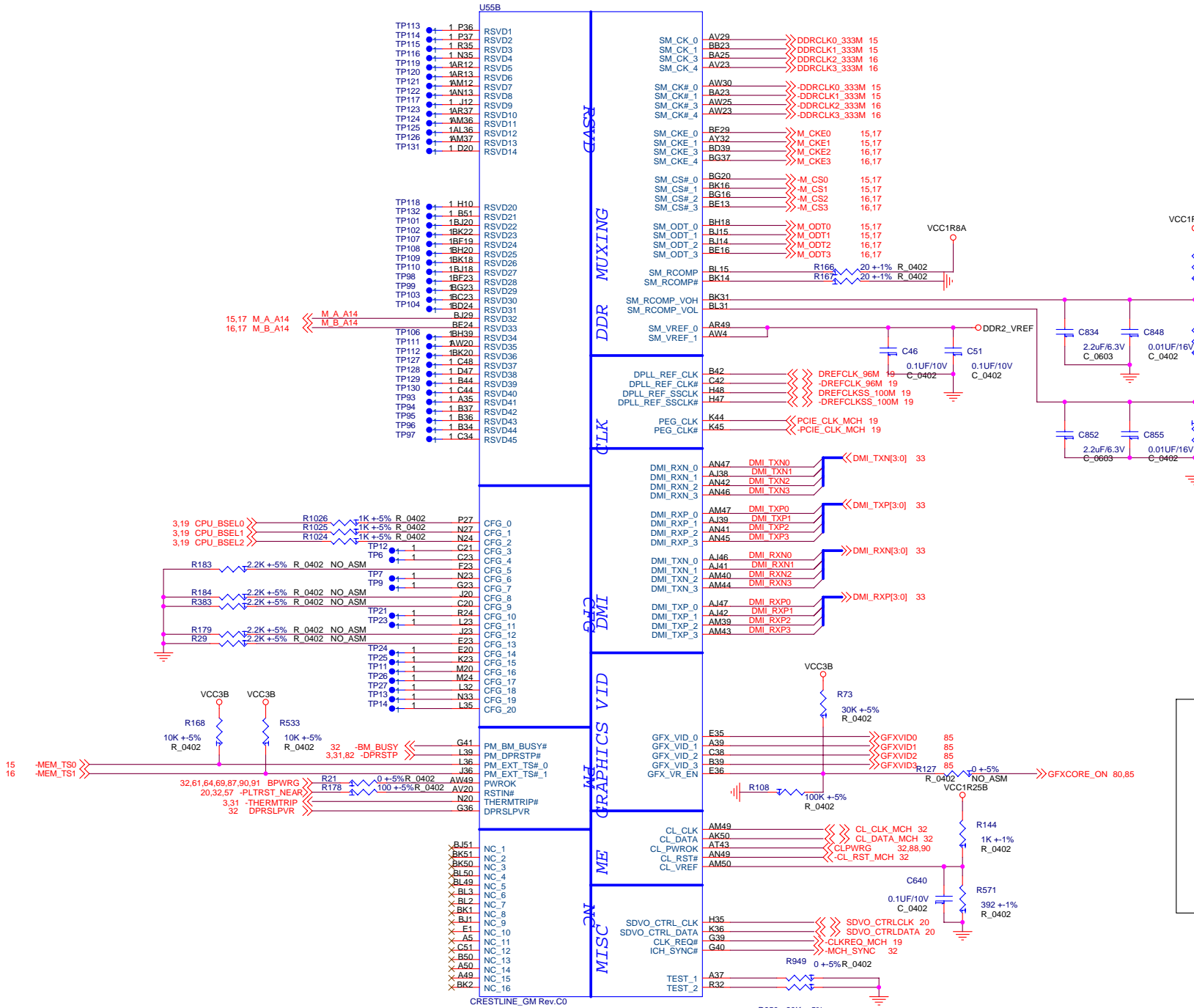

15,17 M.A_A14
16,17 M.B_A14

M.A_A14
M.B_A14

	BSEL2	BSEL1	BSEL0
533M	0	0	1
667M	0	1	1
800M	0	1	0

CFG[17:3] INTERNAL PULLUP
CFG[20:18] INTERNAL PULLDOWN

DMI	R183
	X2:ASM
	X4:NO_ASM
LOW POWER PCIE	R184
	NOMAL :ASM
LOW POWER PCIE	:NO_ASM
LANE REVERSEL	R383
	LANE REVERSEL:ASM
	NORMAL:NO_ASM

DESIGNER	J.CHEN	
CHECKED	Ogawa & OKU	
APPROVED	CHUJO	Part No . XXXXXX
CLASS	CHUJO	EC No . XXXXXX
<small>THIS DOCUMENT IS THE PROPERTY OF LENOVO. ITS USE IS AUTHORIZED ONLY FOR RESPONDING TO A REQUEST FOR QUOTATION OR FOR THE PERFORMANCE OF WORK FOR LENOVO. ALL QUESTIONS MUST BE REFERRED TO THE LENOVO PURCHASING DEPARTMENT.</small>		
TITLE: Waikiki_1.1 Ver. V3.04		
965 DMI		
sheet 10 of 100		
Wednesday, February 14, 2007		
LENOVO CONFIDENTIAL		

CRESTLINE_GM Rev.C0
1299p_bga

R950 20K +5%
R_0402

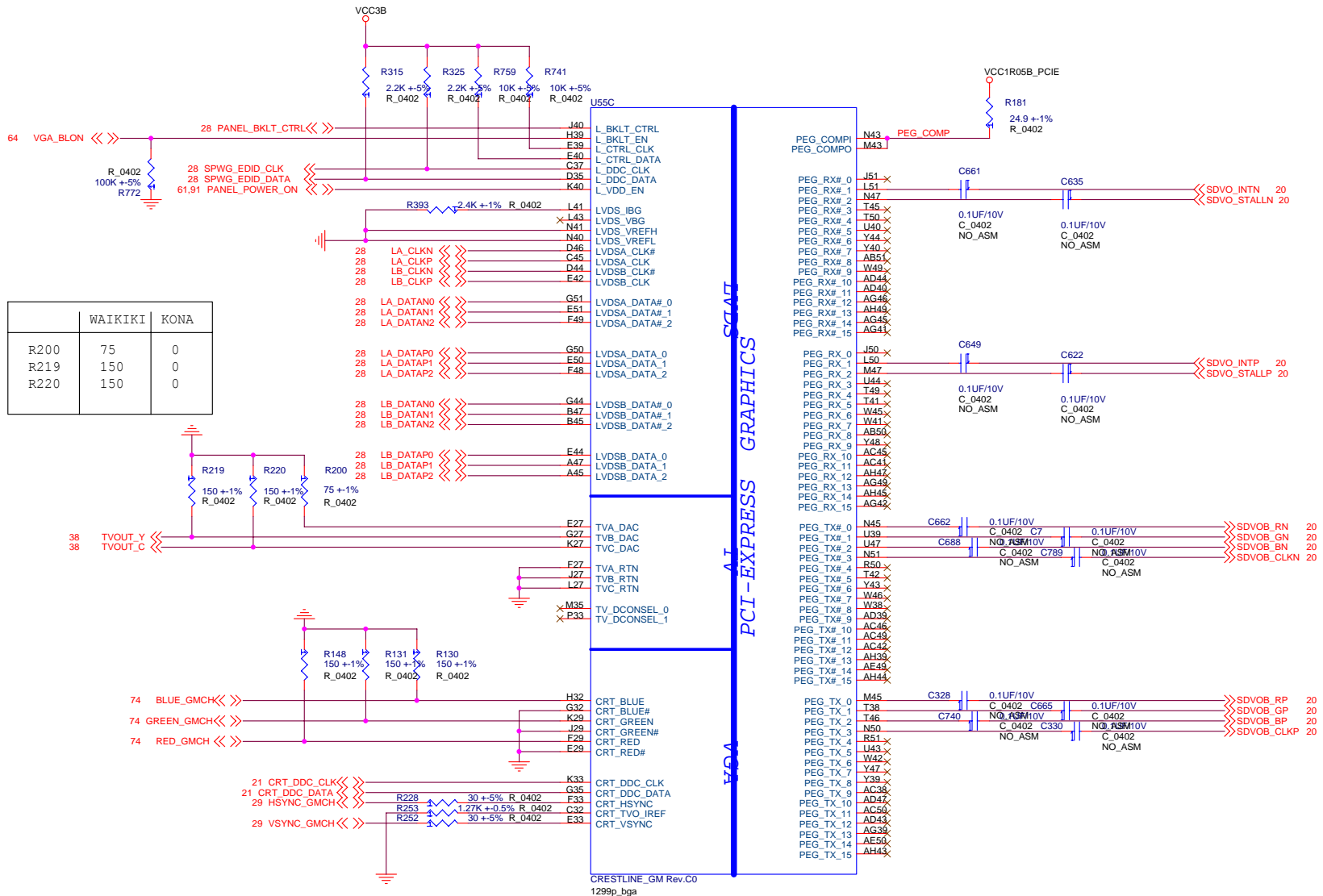

	WAIKIKI	KONA
R200	75	0
R219	150	0
R220	150	0

CRESTLINE_GM Rev.C0
1299p_bga

DESIGNER	J.CHEN	
CHECKED	Ogawa & OKU	
APPROVED	CHUJO	Part No. XXXXXX
CLASS	CHUJO	EC No. XXXXXX
<small>THIS DOCUMENT IS THE PROPERTY OF LENOVO. ITS USE IS AUTHORIZED ONLY FOR RESPONDING TO A REQUEST FOR QUOTATION OR FOR THE PERFORMANCE OF WORK FOR LENOVO. ALL QUESTIONS MUST BE REFERRED TO THE LENOVO PURCHASING DEPARTMENT.</small>		TITLE: Waikiki_1.1 Ver. V3.04
LENOVO CONFIDENTIAL		GRAPHICS
		sheet 11 of 100 Wednesday, February 14, 2007

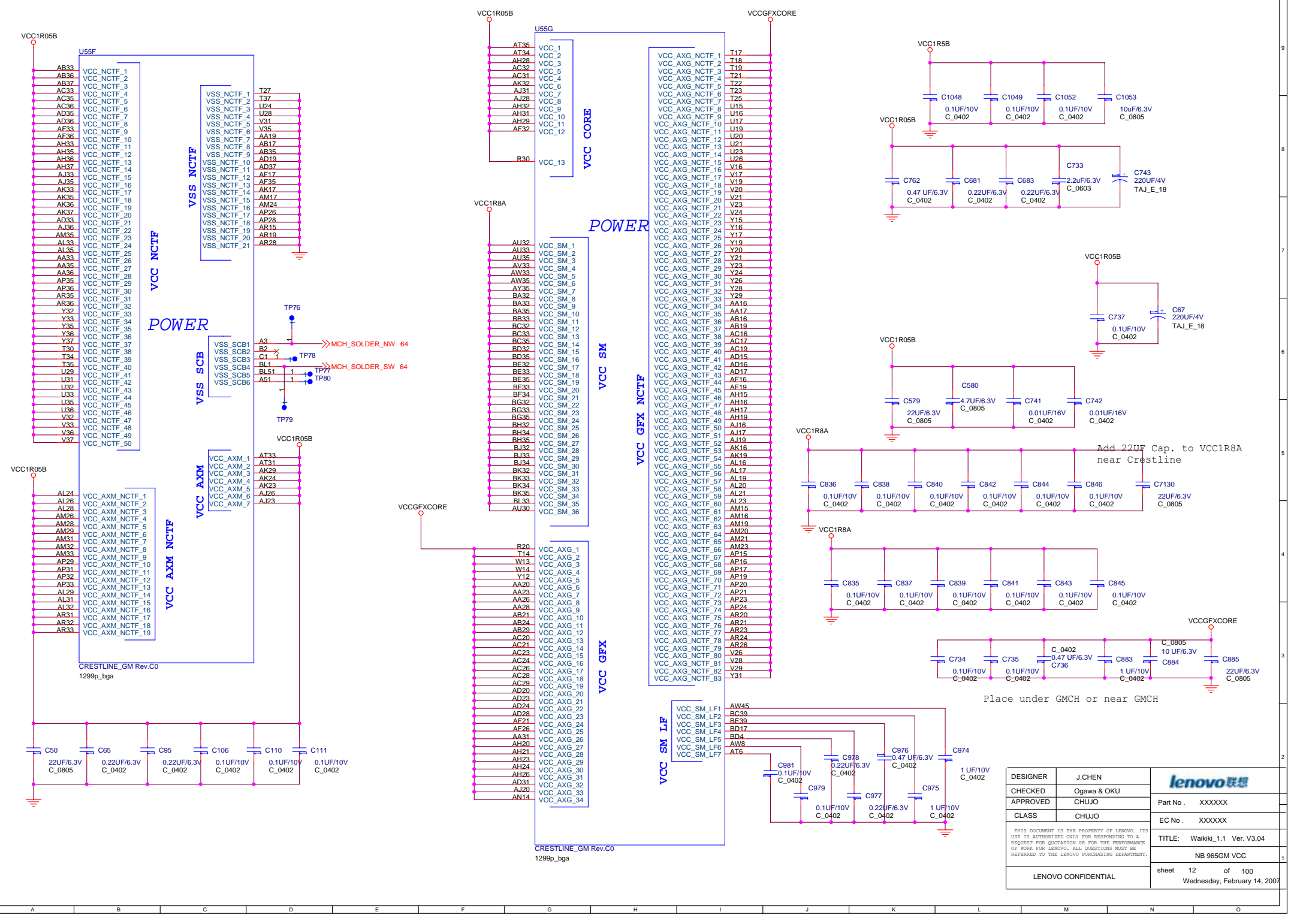

CRESTLINE_GM Rev.C0
1299p_bga

CRESTLINE_GM Rev.C0
1299p_bga

DESIGNER	J.CHEN	
CHECKED	Ogawa & OKU	
APPROVED	CHUJO	Part No. XXXXXX
CLASS	CHUJO	EC No. XXXXXX
<small>THIS DOCUMENT IS THE PROPERTY OF LENOVO. ITS USE IS AUTHORIZED ONLY FOR RESPONDING TO A REQUEST FOR QUOTATION OR FOR THE PERFORMANCE OF WORK FOR LENOVO. ALL QUESTIONS MUST BE REFERRED TO THE LENOVO PURCHASING DEPARTMENT.</small>		TITLE: Waikiki_1 Ver. V3.04
LENOVO CONFIDENTIAL		NB 965GM VCC
sheet 12 of 100		Wednesday, February 14, 2007

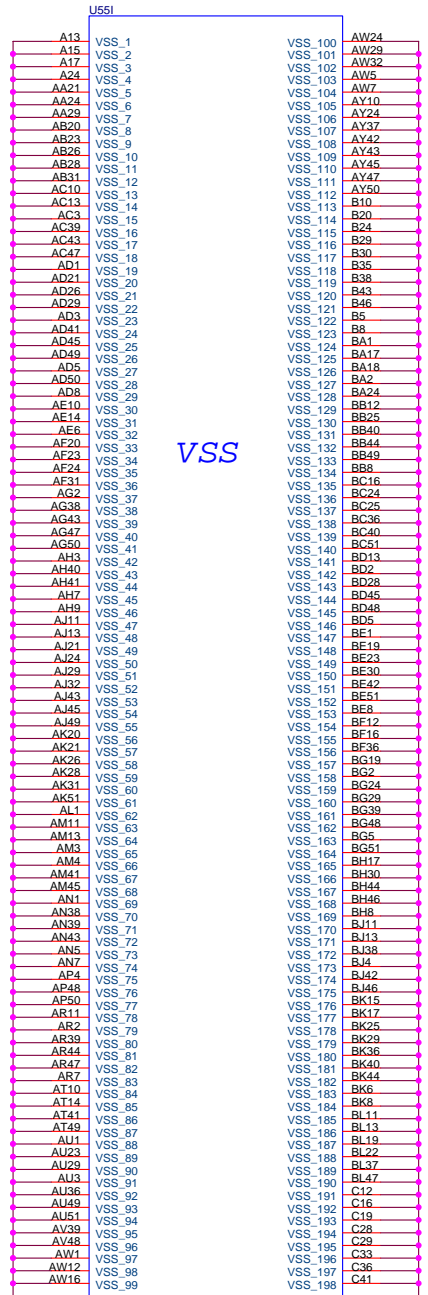

CRESTLINE_GM Rev.C0
1299p_bga

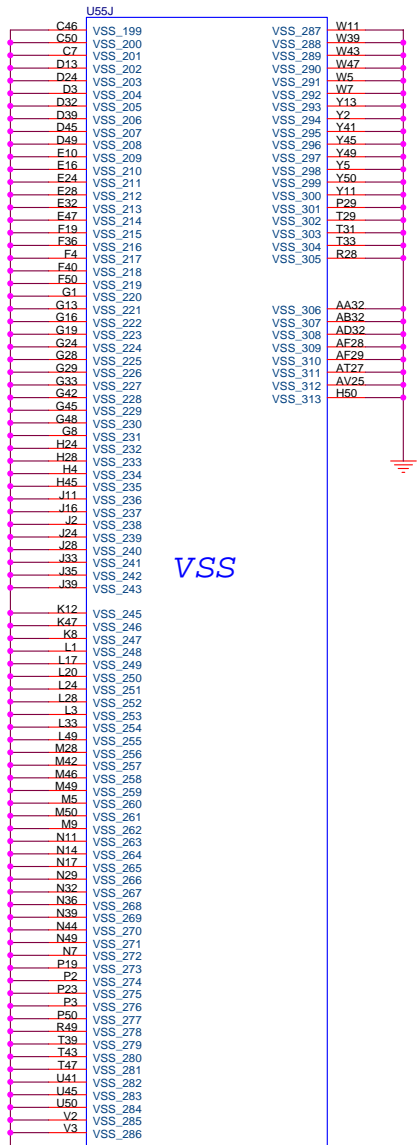

CRESTLINE_GM Rev.C0
1299p_bga

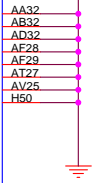

DESIGNER	J.CHEN	
CHECKED	Ogawa & OKU	
APPROVED	CHUJO	Part No . XXXXXX
CLASS	CHUJO	EC No . XXXXXX
THIS DOCUMENT IS THE PROPERTY OF LENOVO. ITS USE IS AUTHORIZED ONLY FOR RESPONDING TO A REQUEST FOR QUOTATION OR FOR THE PERFORMANCE OF WORK FOR LENOVO. ALL QUESTIONS MUST BE REFERRED TO THE LENOVO PURCHASING DEPARTMENT.		
		TITLE: Waikiki_1.1 Ver. V3.04
GND		
LENOVO CONFIDENTIAL		sheet 13 of 100 Wednesday, February 14, 2007

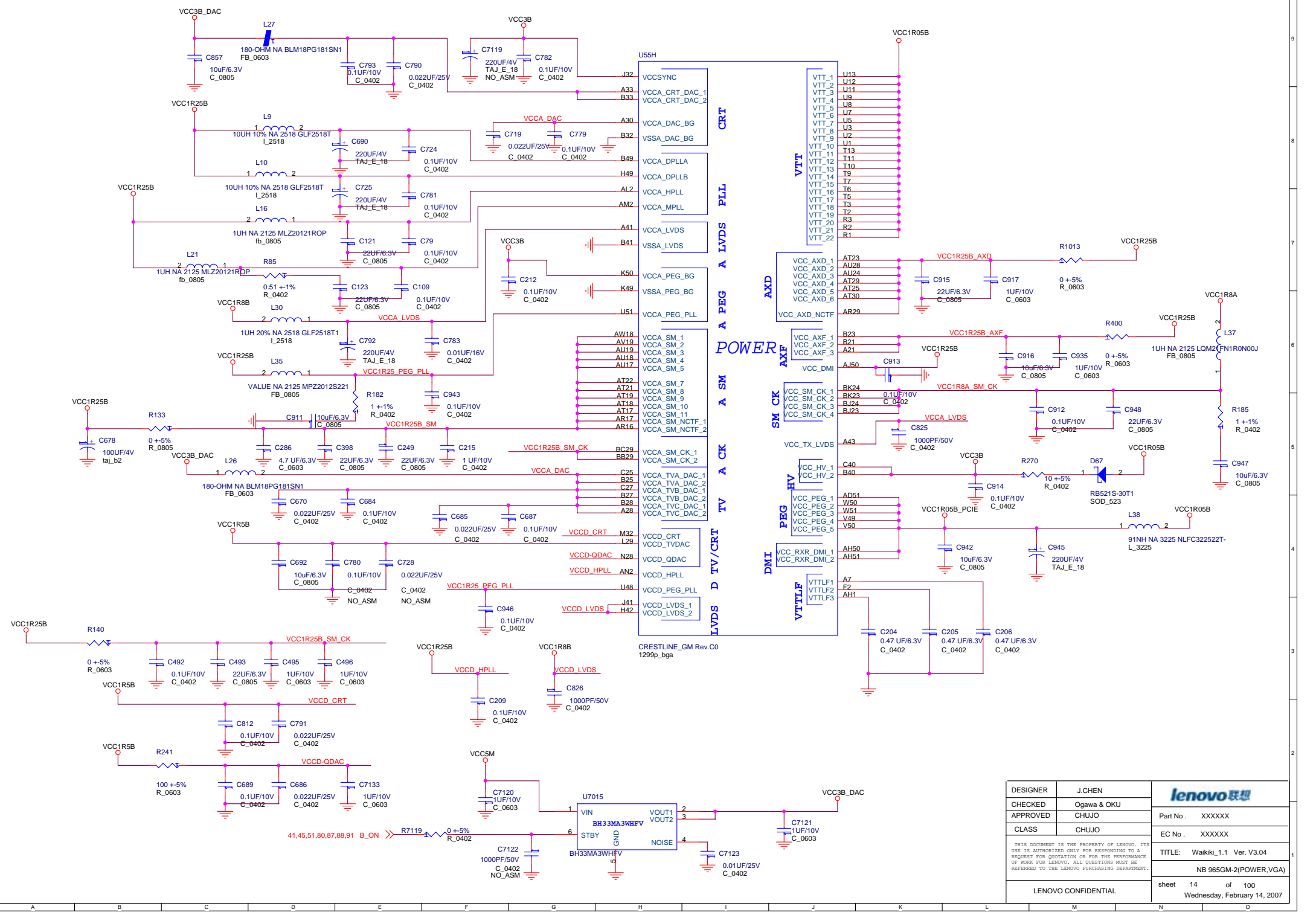

DESIGNER	J.CHEN	
CHECKED	Ogawa & OKU	
APPROVED	CHUJO	Part No. XXXXXX
CLASS	CHUJO	EC No. XXXXXX
<small>THIS DOCUMENT IS THE PROPERTY OF LENOVO. ITS USE IS AUTHORIZED ONLY FOR RESPONDING TO A REQUEST FOR QUOTATION OR FOR THE PERFORMANCE OF WORK FOR LENOVO. ALL QUESTIONS MUST BE REFERRED TO THE LENOVO PURCHASING DEPARTMENT.</small>		
		TITLE: Waikiki 1.1 Ver. V3.04
		NB 965GM-2(POWER,VGA)
LENOVO CONFIDENTIAL		sheet 14 of 100 Wednesday, February 14, 2007

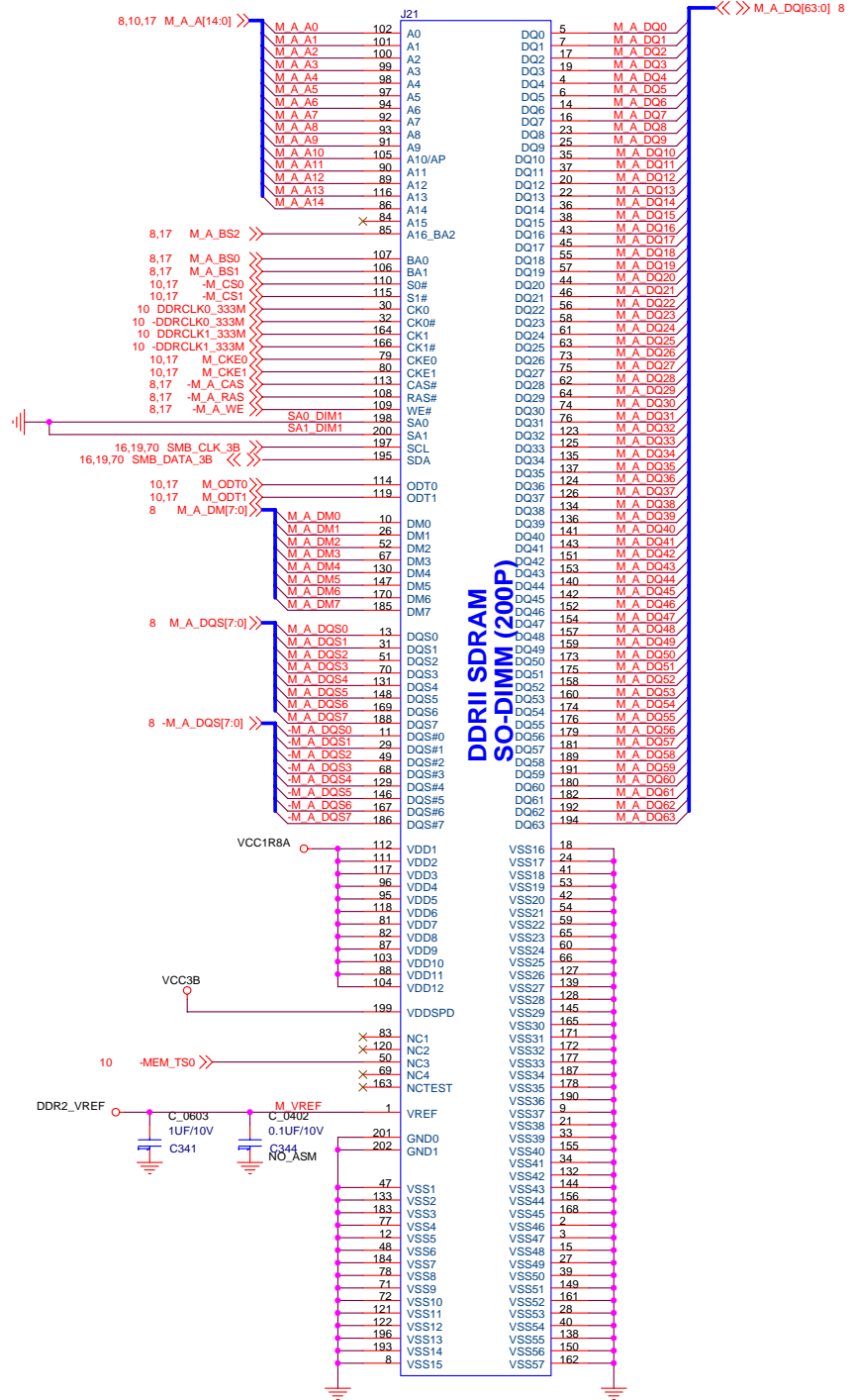

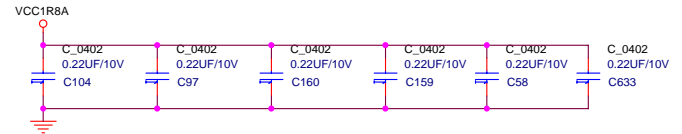
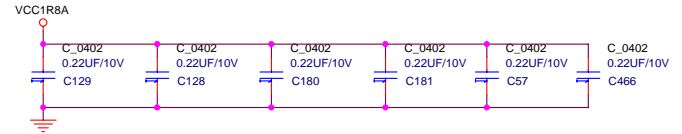
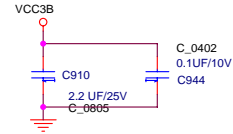
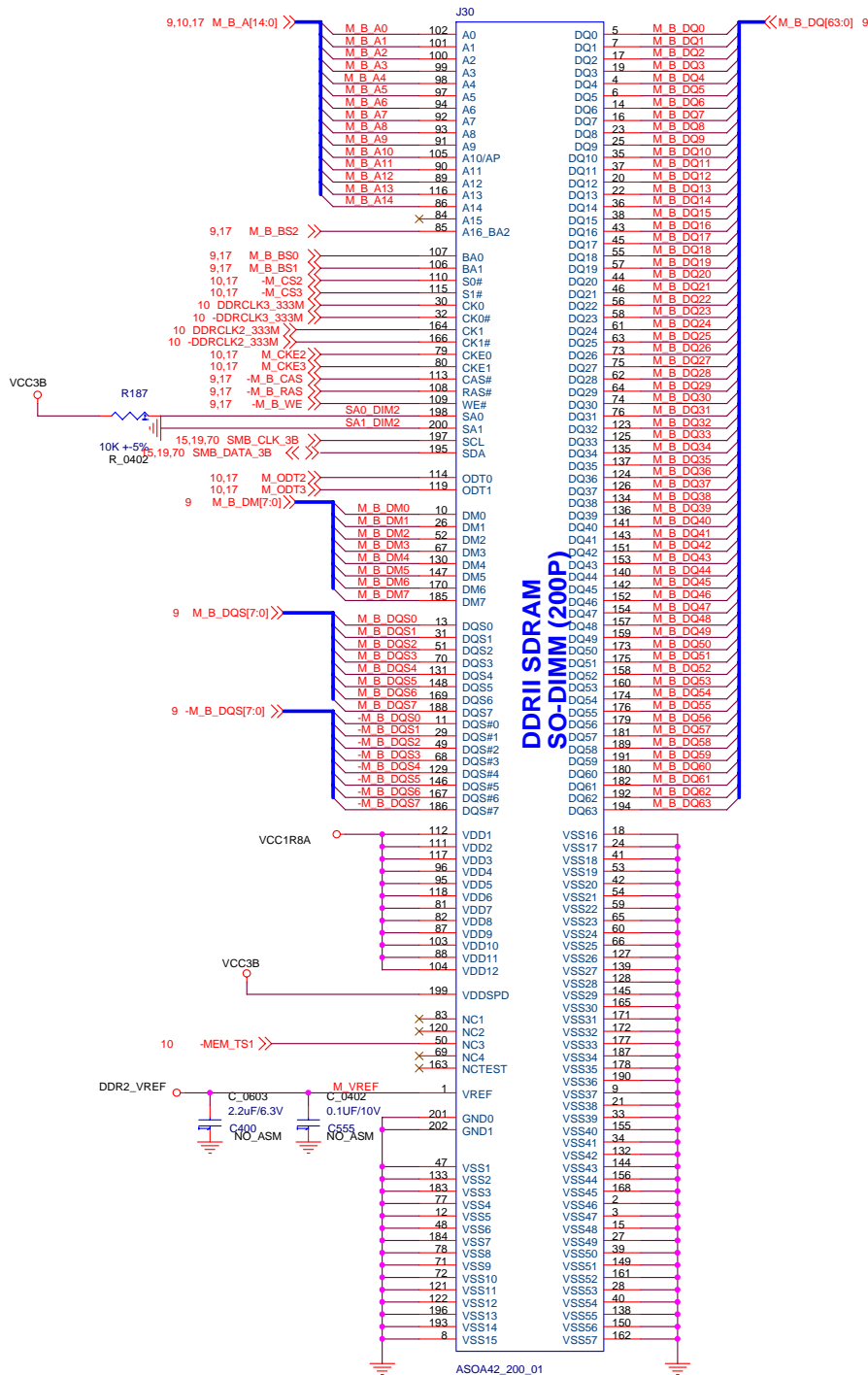

Add two more 0.22uf/10v for VCC1R8A at J30

DESIGNER	J.CHEN	
CHECKED	Ogawa & OKU	
APPROVED	CHUJUO	Part No. XXXXXX
CLASS	CHUJUO	EC No. XXXXXX
<small>THIS DOCUMENT IS THE PROPERTY OF LENOVO. ITS USE IS AUTHORIZED ONLY FOR RESPONDING TO A REQUEST FOR QUOTATION OR FOR THE PERFORMANCE OF WORK FOR LENOVO. ALL QUESTIONS MUST BE REFERRED TO THE LENOVO PURCHASING DEPARTMENT.</small>		
TITLE: Waikiki_1.1 Ver. V3.04		
DDRII 2		
sheet 16 of 100		
Wednesday, February 14, 2007		
LENOVO CONFIDENTIAL		

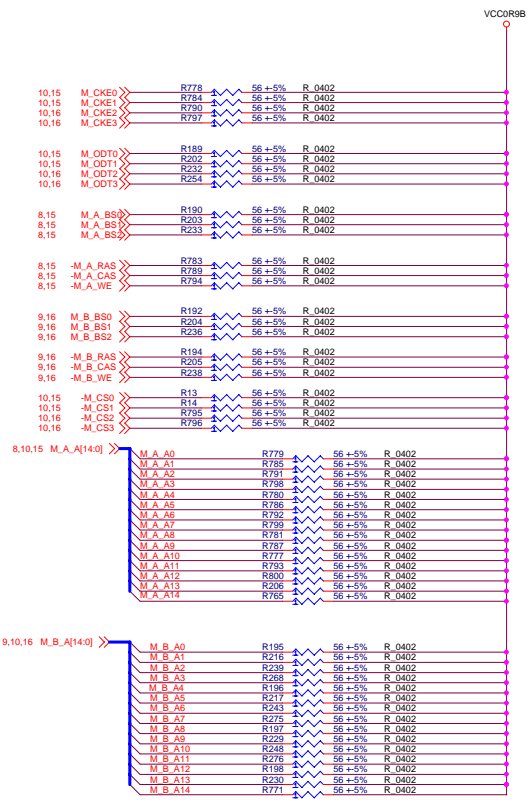

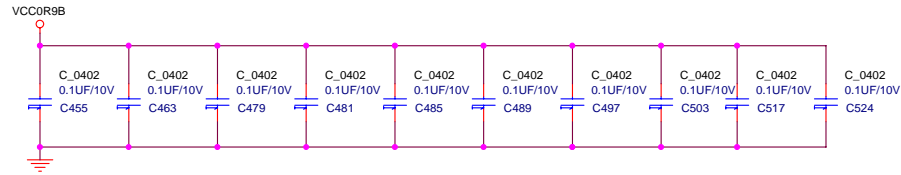
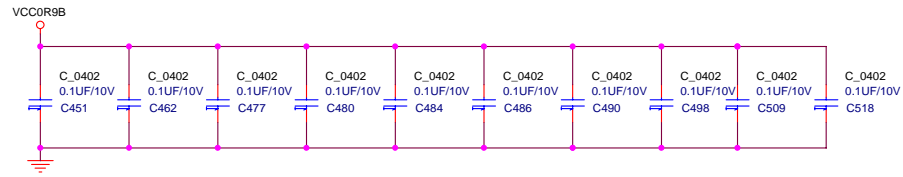

DESIGNER	J.CHEN	
CHECKED	Ogawa & OKU	
APPROVED	CHUJO	Part No. XXXXXX
CLASS	CHUJO	EC No. XXXXXX
<small>THIS DOCUMENT IS THE PROPERTY OF LENOVO. ITS USE IS AUTHORIZED ONLY FOR RESPONDING TO A REQUEST FOR QUOTATION OR FOR THE PERFORMANCE OF WORK FOR LENOVO. ALL QUESTIONS MUST BE REFERRED TO THE LENOVO PURCHASING DEPARTMENT.</small>		TITLE: Waikui_1.1 Ver. V3.04
		DDR2 TERMINATION
LENOVO CONFIDENTIAL		sheet 17 of 100 Wednesday, February 14, 2007

PLACE 1 CAP FOR EVERY 2 BITS TERMINATED TO VCC0R9B.



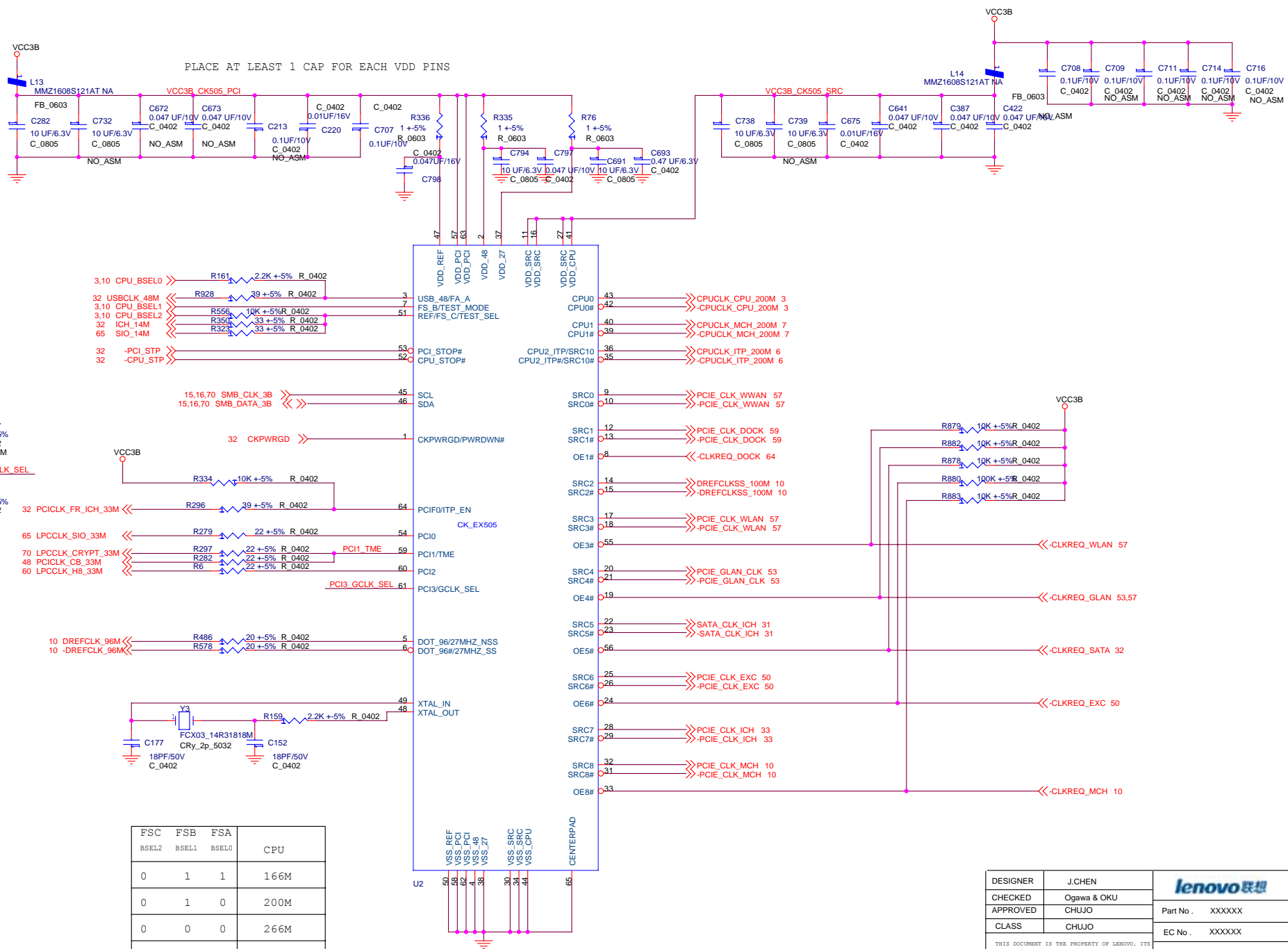

DESIGNER	J.CHEN	
CHECKED	Ogawa & OKU	
APPROVED	CHUJO	Part No . XXXXXX
CLASS	CHUJO	EC No . XXXXXX
<small>THIS DOCUMENT IS THE PROPERTY OF LENOVO. ITS USE IS AUTHORIZED ONLY FOR RESPONDING TO A REQUEST FOR QUOTATION OR FOR THE PERFORMANCE OF WORK FOR LENOVO. ALL QUESTIONS MUST BE REFERRED TO THE LENOVO PURCHASING DEPARTMENT.</small>		TITLE: Waikiki_1.1 Ver. V3.04
LENOVO CONFIDENTIAL		DDR2 DECOUPLING
		sheet 18 of 100 Wednesday, February 14, 2007

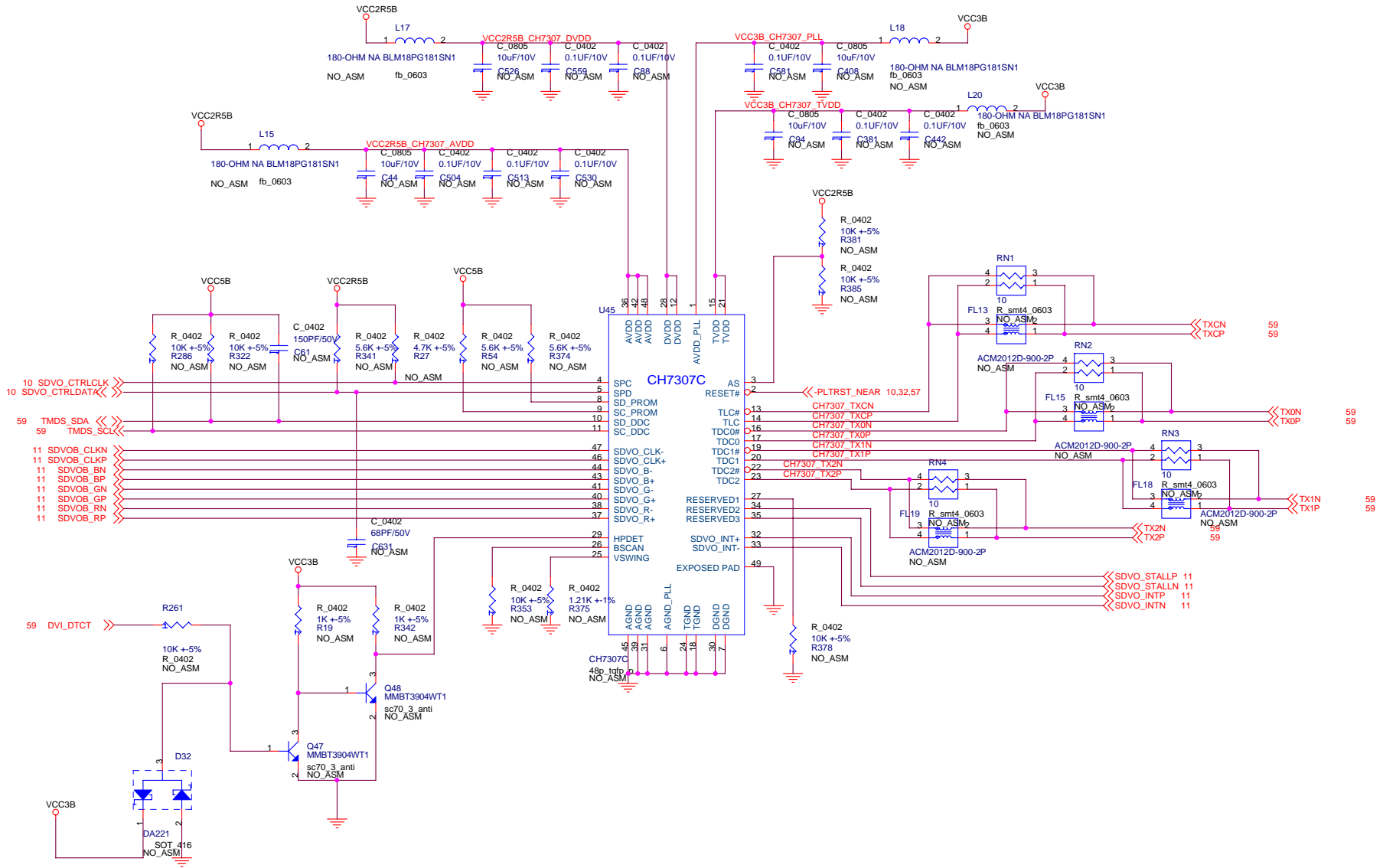

DESIGNER	J.CHEN	
CHECKED	Ogawa & OKU	
APPROVED	CHUJUO	Part No. XXXXXX
CLASS	CHUJUO	EC No. XXXXXX
<small>THIS DOCUMENT IS THE PROPERTY OF LENOVO. ITS USE IS AUTHORIZED ONLY FOR RESPONDING TO A REQUEST FOR QUOTATION OR FOR THE PERFORMANCE OF WORK FOR LENOVO. ALL QUESTIONS MUST BE REFERRED TO THE LENOVO PURCHASING DEPARTMENT.</small>		
TITLE: Waikiki_1.1 Ver. V3.04		
CLOCK GENERATOR		
sheet 19 of 100		
Wednesday, February 14, 2007		

LENOVO CONFIDENTIAL



DESIGNER	J.CHEN	
CHECKED	Ogawa & OKU	
APPROVED	CHUJO	Part No. XXXXXX
CLASS	CHUJO	EC No. XXXXXX
<small>THIS DOCUMENT IS THE PROPERTY OF LENOVO. ITS USE IS AUTHORIZED ONLY FOR RESPONDING TO A REQUEST FOR QUOTATION OR FOR THE PERFORMANCE OF WORK FOR LENOVO. ALL QUESTIONS MUST BE REFERRED TO THE LENOVO PURCHASING DEPARTMENT.</small>		
TITLE: Waiki_1.1 Ver. V3.04		
DVI		
LENOVO CONFIDENTIAL		
sheet 20 of 100		
Wednesday, February 14, 2007		

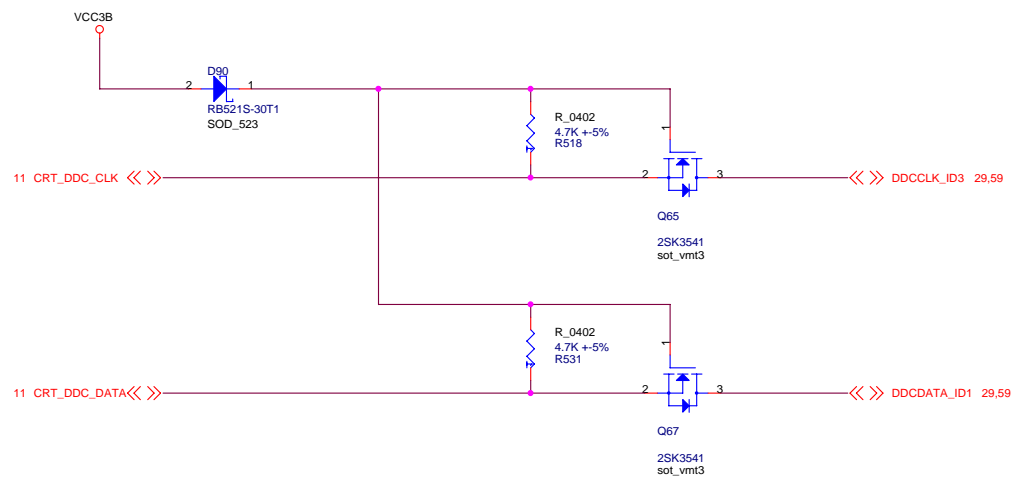

DESIGNER	J.CHEN	
CHECKED	Ogawa & OKU	
APPROVED	CHUJO	Part No . XXXXXX
CLASS	CHUJO	EC No . XXXXXX
<small>THIS DOCUMENT IS THE PROPERTY OF LENOVO. ITS USE IS AUTHORIZED ONLY FOR RESPONDING TO A REQUEST FOR QUOTATION OR FOR THE PERFORMANCE OF WORK FOR LENOVO. ALL QUESTIONS MUST BE REFERRED TO THE LENOVO PURCHASING DEPARTMENT.</small>		TITLE: Waiki_1.1 Ver. V3.04
LENOVO CONFIDENTIAL		CRT DDC CLK/DATA
		sheet 21 of 100 Wednesday, February 14, 2007

28 LED_BDC_IN >>

R_0402
0 +5%
R126

>>LED_WPAN 28

DESIGNER	J.CHEN	
CHECKED	Ogawa & OKU	
APPROVED	CHUJO	Part No . XXXXXX
CLASS	CHUJO	EC No . XXXXXX
<small>THIS DOCUMENT IS THE PROPERTY OF LENOVO. ITS USE IS AUTHORIZED ONLY FOR RESPONDING TO A REQUEST FOR QUOTATION OR FOR THE PERFORMANCE OF WORK FOR LENOVO. ALL QUESTIONS MUST BE REFERRED TO THE LENOVO PURCHASING DEPARTMENT.</small>		TITLE: Waikiki_1.1 Ver. V3.04
LENOVO CONFIDENTIAL		WPAN LED CONTROL
		sheet 22 of 100 Wednesday, February 14, 2007

Notic:Change LED to right-angle type.

D7006
SML_A10MT
LED_0603_RA

XD D[7..0],-XD_RE,-XD_WE should be the same trace length
-XD_RE(SD_CLK and MS_CLK) need GND guard

DESIGNER	J.CHEN	
CHECKED	Ogawa & OKU	
APPROVED	CHUJO	Part No . XXXXXX
CLASS	CHUJO	EC No . XXXXXX
THIS DOCUMENT IS THE PROPERTY OF LENOVO. ITS USE IS AUTHORIZED ONLY FOR RESPONDING TO A REQUEST FOR QUOTATION OR FOR THE PERFORMANCE OF WORK FOR LENOVO. ALL QUESTIONS MUST BE REFERRED TO THE LENOVO PURCHASING DEPARTMENT.		TITLE: Waikiki_1.1 Ver. V3.04
LENOVO CONFIDENTIAL		DAV3_INTEG_SIV_W
		sheet 23 of 100 Wednesday, February 14, 2007

BLACK PAGE

DESIGNER	J.CHEN	
CHECKED	Ogawa & OKU	
APPROVED	CHUJO	Part No . XXXXXX
CLASS	CHUJO	EC No . XXXXXX
<small>THIS DOCUMENT IS THE PROPERTY OF LENOVO. ITS USE IS AUTHORIZED ONLY FOR RESPONDING TO A REQUEST FOR QUOTATION OR FOR THE PERFORMANCE OF WORK FOR LENOVO. ALL QUESTIONS MUST BE REFERRED TO THE LENOVO PURCHASING DEPARTMENT.</small>		TITLE: Waikiki_1.1 Ver. V3.04
LENOVO CONFIDENTIAL		BLANK
		sheet 24 of 100 Wednesday, February 14, 2007

BLACK PAGE

DESIGNER	J.CHEN	
CHECKED	Ogawa & OKU	
APPROVED	CHUJO	Part No . XXXXXX
CLASS	CHUJO	EC No . XXXXXX
<small>THIS DOCUMENT IS THE PROPERTY OF LENOVO. ITS USE IS AUTHORIZED ONLY FOR RESPONDING TO A REQUEST FOR QUOTATION OR FOR THE PERFORMANCE OF WORK FOR LENOVO. ALL QUESTIONS MUST BE REFERRED TO THE LENOVO PURCHASING DEPARTMENT.</small>		TITLE: Waikiki_1.1 Ver. V3.04
LENOVO CONFIDENTIAL		BLANK
		sheet 25 of 100 Wednesday, February 14, 2007

BLACK PAGE

DESIGNER	J.CHEN	
CHECKED	Ogawa & OKU	
APPROVED	CHUJO	Part No . XXXXXX
CLASS	CHUJO	EC No . XXXXXX
<small>THIS DOCUMENT IS THE PROPERTY OF LENOVO. ITS USE IS AUTHORIZED ONLY FOR RESPONDING TO A REQUEST FOR QUOTATION OR FOR THE PERFORMANCE OF WORK FOR LENOVO. ALL QUESTIONS MUST BE REFERRED TO THE LENOVO PURCHASING DEPARTMENT.</small>		TITLE: Waikiki_1.1 Ver. V3.04
LENOVO CONFIDENTIAL		BLANK
		sheet 26 of 100 Wednesday, February 14, 2007

BLACK PAGE

DESIGNER	J.CHEN	
CHECKED	Ogawa & OKU	
APPROVED	CHUJO	Part No . XXXXXX
CLASS	CHUJO	EC No . XXXXXX
<small>THIS DOCUMENT IS THE PROPERTY OF LENOVO. ITS USE IS AUTHORIZED ONLY FOR RESPONDING TO A REQUEST FOR QUOTATION OR FOR THE PERFORMANCE OF WORK FOR LENOVO. ALL QUESTIONS MUST BE REFERRED TO THE LENOVO PURCHASING DEPARTMENT.</small>		TITLE: Waikiki_1.1 Ver. V3.04
LENOVO CONFIDENTIAL		Check Point Card
		sheet 27 of 100 Wednesday, February 14, 2007

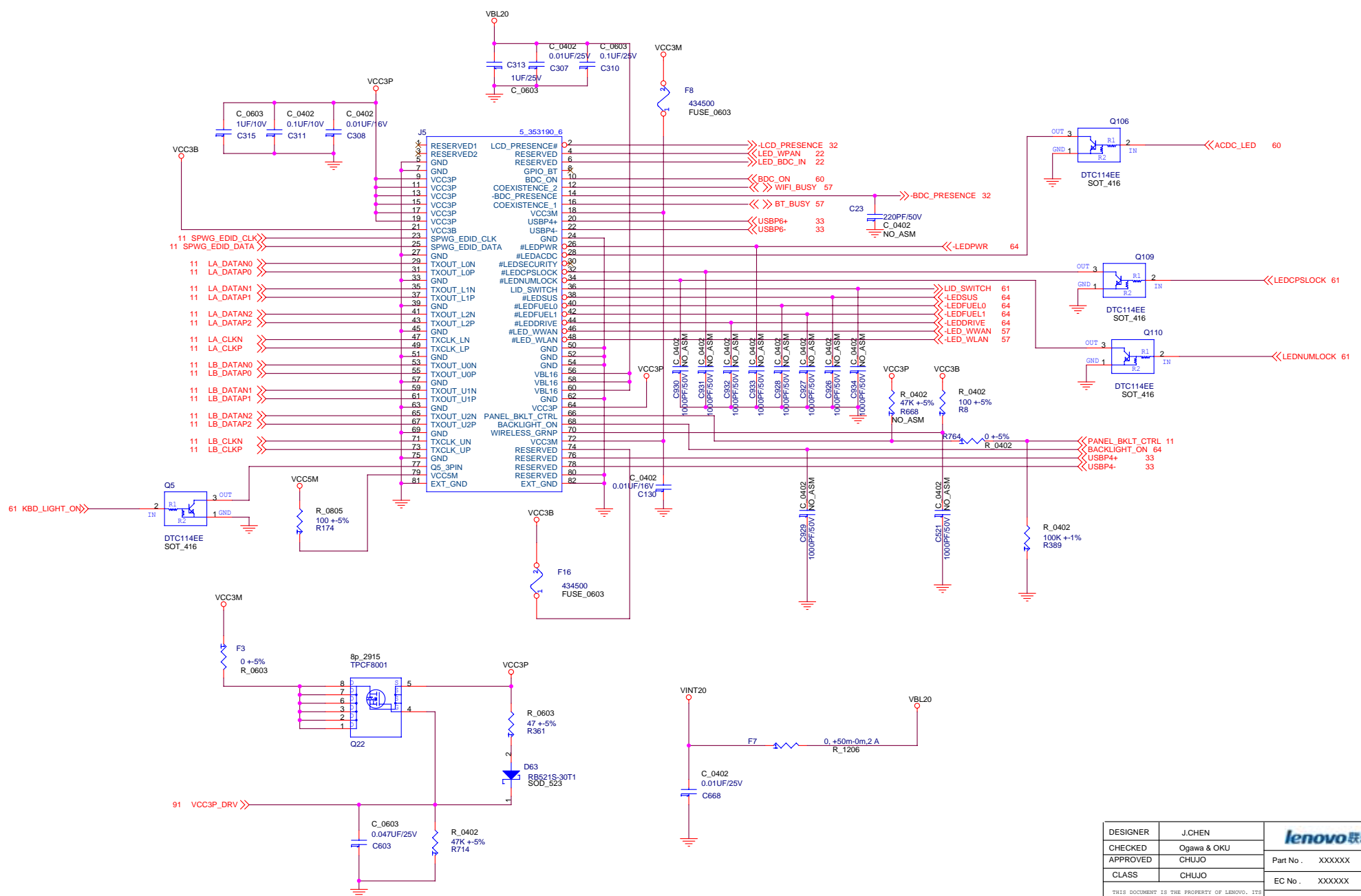

DESIGNER	J.CHEN	
CHECKED	Ogawa & OKU	
APPROVED	CHUJO	Part No. XXXXXX
CLASS	CHUJO	EC No. XXXXXX
<small>THIS DOCUMENT IS THE PROPERTY OF LENOVO. ITS USE IS AUTHORIZED ONLY FOR RESPONDING TO A REQUEST FOR QUOTATION OR FOR THE PERFORMANCE OF WORK FOR LENOVO. ALL QUESTIONS MUST BE REFERRED TO THE LENOVO PURCHASING DEPARTMENT.</small>		
TITLE: Waikiki_1.1 Ver. V3.04		
LCD_CONN		
sheet 28 of 100 Wednesday, February 14, 2007		
LENOVO CONFIDENTIAL		

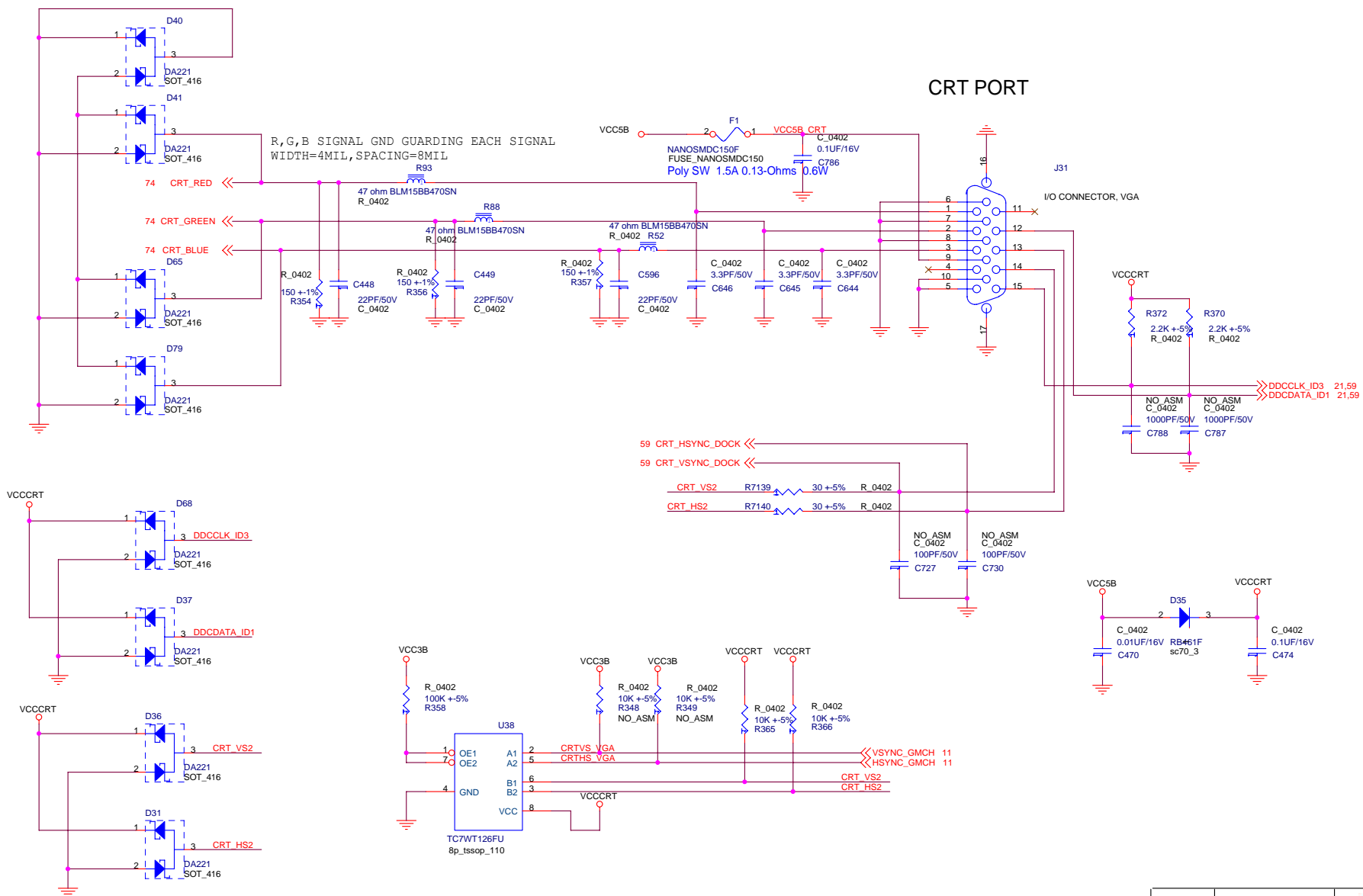

CRT PORT

DESIGNER	J.CHEN	
CHECKED	Ogawa & OKU	
APPROVED	CHUJO	Part No. XXXXXX
CLASS	CHUJO	EC No. XXXXXX
<small>THIS DOCUMENT IS THE PROPERTY OF LENOVO. ITS USE IS AUTHORIZED ONLY FOR RESPONDING TO A REQUEST FOR QUOTATION OR FOR THE PERFORMANCE OF WORK FOR LENOVO. ALL QUESTIONS MUST BE REFERRED TO THE LENOVO PURCHASING DEPARTMENT.</small>		TITLE: Waiki_1.1 Ver. V3.04
LENOVO CONFIDENTIAL		VGA_CONN
		sheet 29 of 100
		Wednesday, February 14, 2007

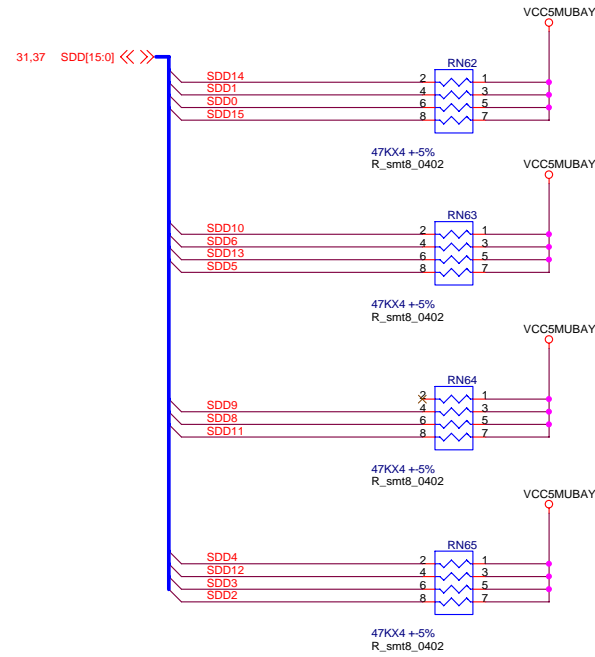

DESIGNER	J.CHEN	
CHECKED	Ogawa & OKU	
APPROVED	CHUJO	Part No . XXXXXX
CLASS	CHUJO	EC No . XXXXXX
<small>THIS DOCUMENT IS THE PROPERTY OF LENOVO. ITS USE IS AUTHORIZED ONLY FOR RESPONDING TO A REQUEST FOR QUOTATION OR FOR THE PERFORMANCE OF WORK FOR LENOVO. ALL QUESTIONS MUST BE REFERRED TO THE LENOVO PURCHASING DEPARTMENT.</small>		TITLE: Waikiki_1.1 Ver. V3.04
LENOVO CONFIDENTIAL		PATA I/F PU
		sheet 30 of 100 Wednesday, February 14, 2007

Layout Note:
Place all series resistors 0.6 to 2.6 inches from the ICH

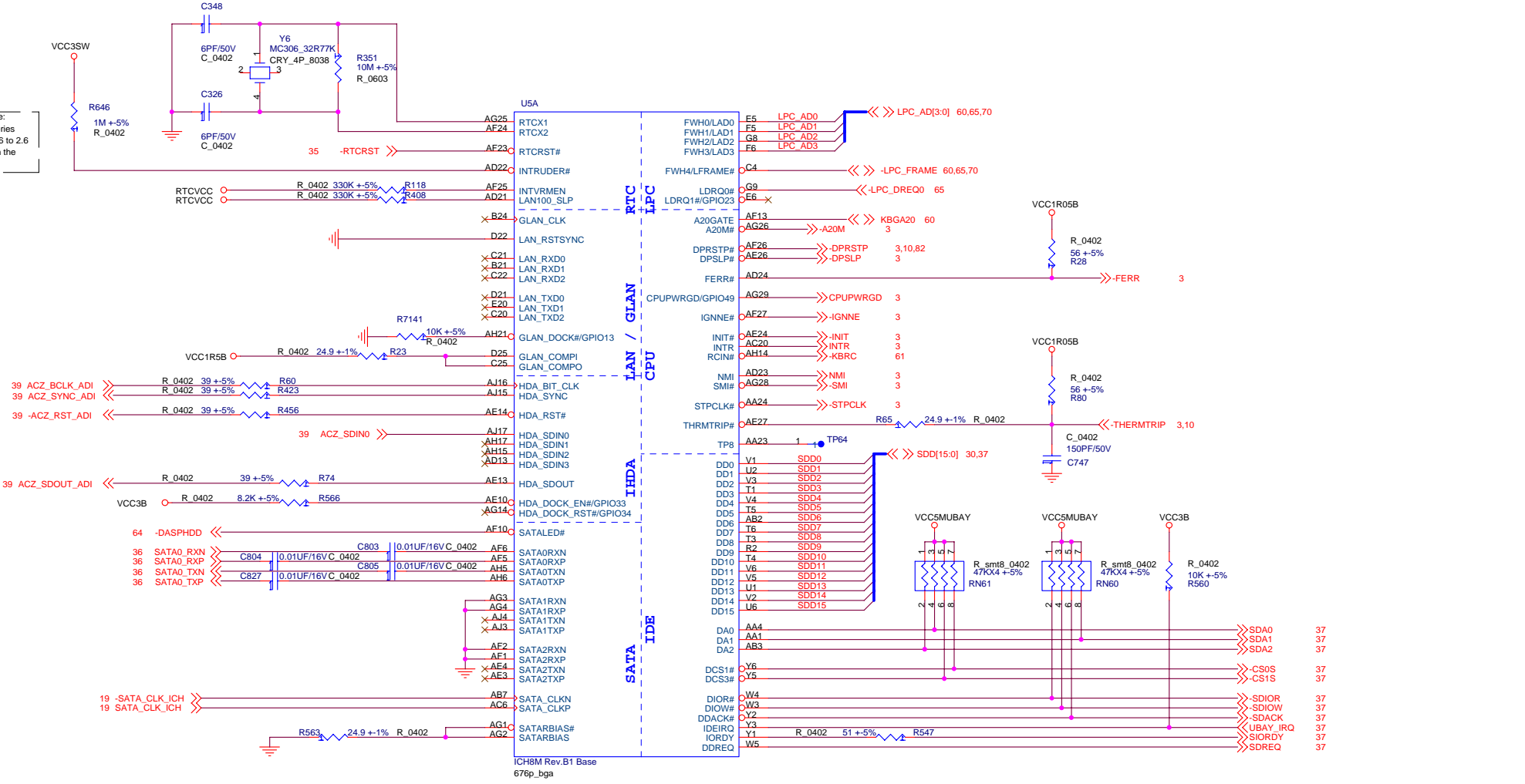

DESIGNER	J.CHEN	
CHECKED	Ogawa & OKU	
APPROVED	CHUJO	Part No. XXXXXX
CLASS	CHUJO	EC No. XXXXXX
THIS DOCUMENT IS THE PROPERTY OF LENOVO. ITS USE IS AUTHORIZED ONLY FOR RESPONDING TO A REQUEST FOR QUOTATION OR FOR THE PERFORMANCE OF WORK FOR LENOVO. ALL QUESTIONS MUST BE REFERRED TO THE LENOVO PURCHASING DEPARTMENT.		TITLE: Waikiki_1.1 Ver. V3.04
LENOVO CONFIDENTIAL		SB ICH8M-1
		sheet 31 of 100
		Wednesday, February 14, 2007

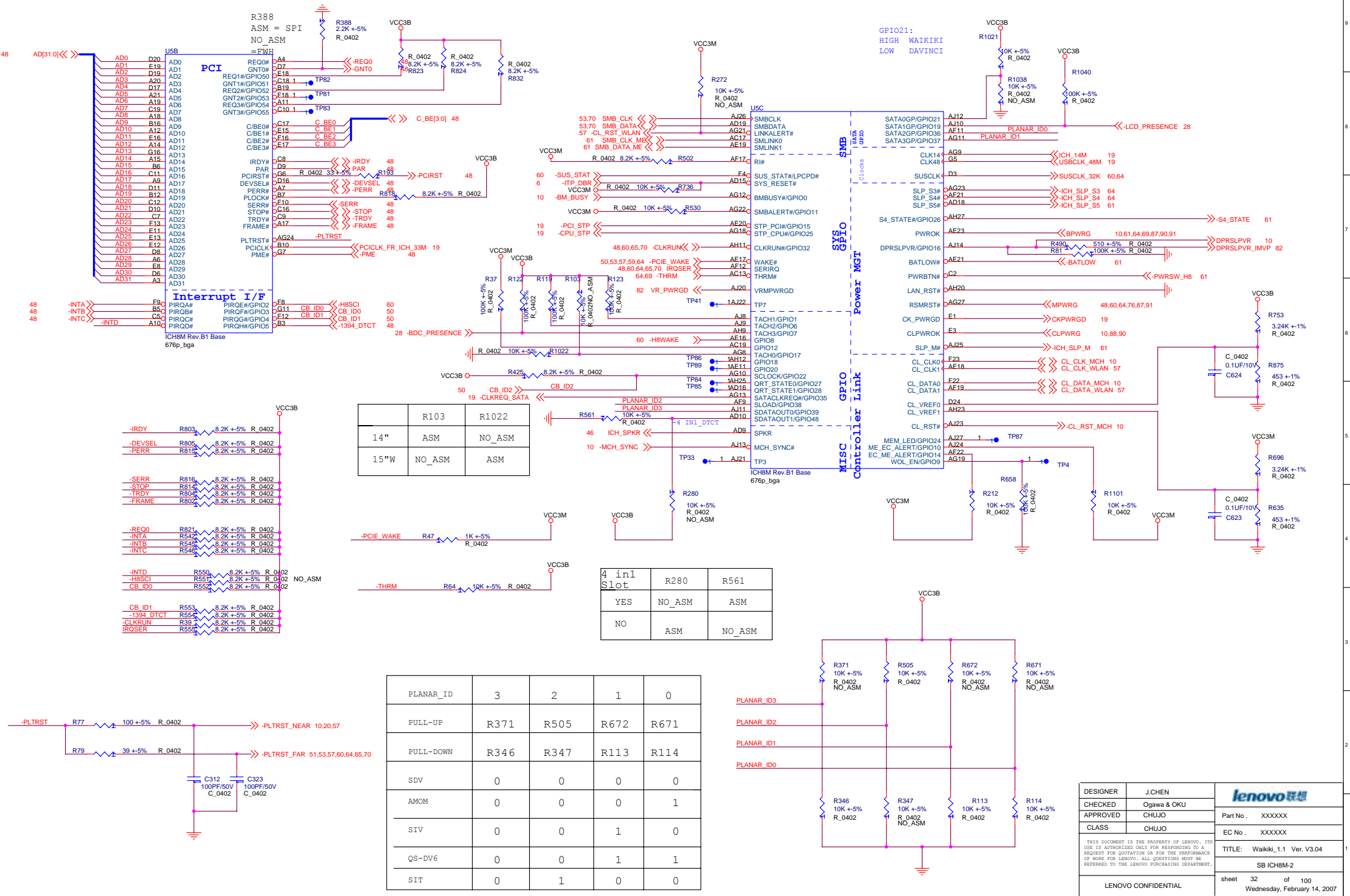

	R103	R1022
14"	ASM	NO_ASM
15"W	NO_ASM	ASM

4 in1 Slot	R280	R561
YES	NO_ASM	ASM
NO	ASM	NO_ASM

PLANAR_ID	3	2	1	0
PULL-UP	R371	R505	R672	R671
PULL-DOWN	R346	R347	R113	R114
SDV	0	0	0	0
AMOM	0	0	0	1
SIV	0	0	1	0
QS-DV6	0	0	1	1
SIT	0	1	0	0

DESIGNER	J.CHEN	
CHECKED	Ogawa & OKU	
APPROVED	CHUJO	
CLASS	CHUJO	
THIS DOCUMENT IS THE PROPERTY OF LENOVO. ITS USE IS AUTHORIZED ONLY FOR RESPONDING TO A REQUEST FOR QUOTATION OR FOR THE PERFORMANCE OF WORK FOR LENOVO. ALL QUESTIONS MUST BE REFERRED TO THE LENOVO PURCHASING DEPARTMENT.		
LENOVO CONFIDENTIAL		Part No. XXXXXX EC No. XXXXXX TITLE: Waikiki_1.1 Ver. V3.04 SB ICH8M-2 sheet 32 of 100 Wednesday, February 14, 2007

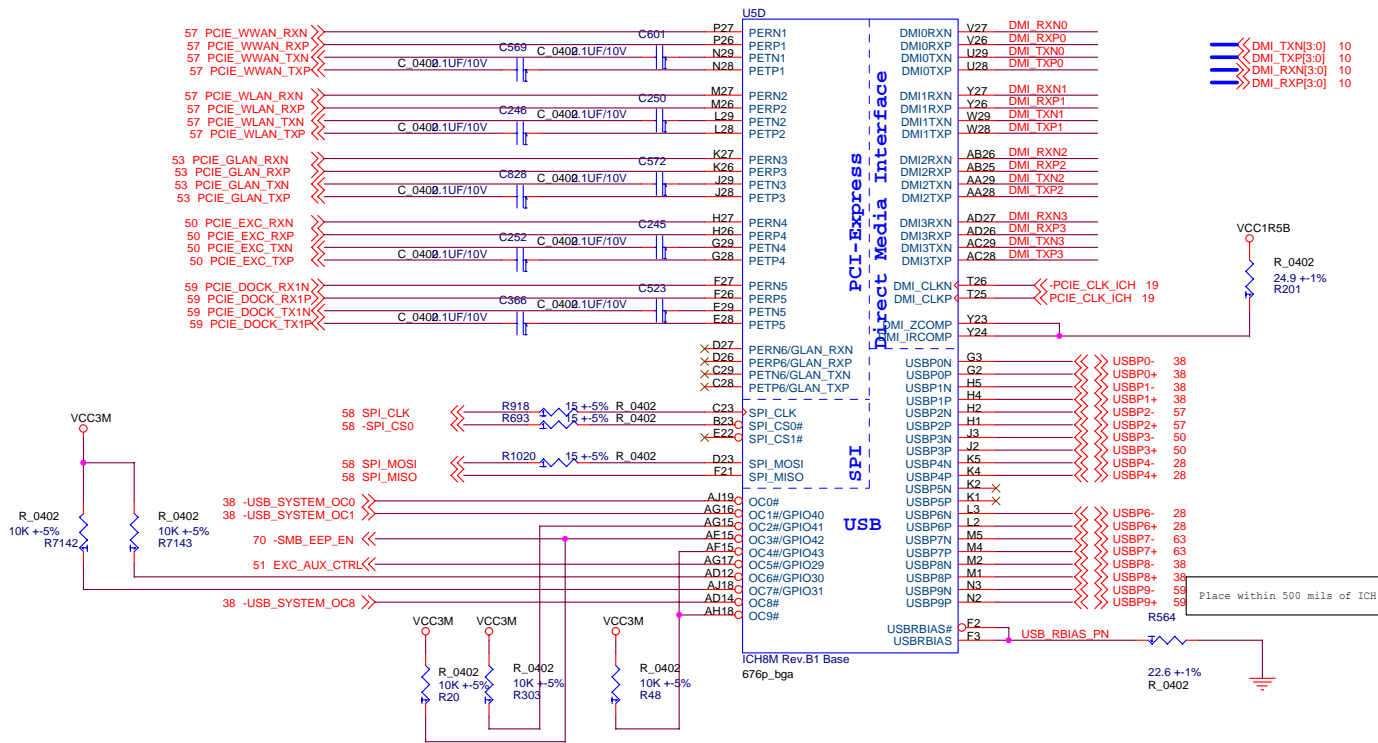

- 0 : USB Port
- 1 : USB Port
- 2 : PCIE MINICARD
- 3 : TO PCI EXPRESS CARD
- 4 : TO CAMERA (LCD CONN)
- 5 : NC
- 6 : TO BLUETOOTH
- 7 : TO FINGER PRINT
- 8 : USB PORT3
- 9 : TO DOCKING USB HUB

Place within 500 mils of ICH

Place within 500 mils of ICH

DESIGNER	J.CHEN	
CHECKED	Ogawa & OKU	
APPROVED	CHUJO	Part No. XXXXXX
CLASS	CHUJO	EC No. XXXXXX
<small>THIS DOCUMENT IS THE PROPERTY OF LENOVO. ITS USE IS AUTHORIZED ONLY FOR RESPONDING TO A REQUEST FOR QUOTATION OR FOR THE PERFORMANCE OF WORK FOR LENOVO. ALL QUESTIONS MUST BE REFERRED TO THE LENOVO PURCHASING DEPARTMENT.</small>		TITLE: Waiki_1.1 Ver. V3.04
LENOVO CONFIDENTIAL		IC8-3
		sheet 33 of 100 Wednesday, February 14, 2007

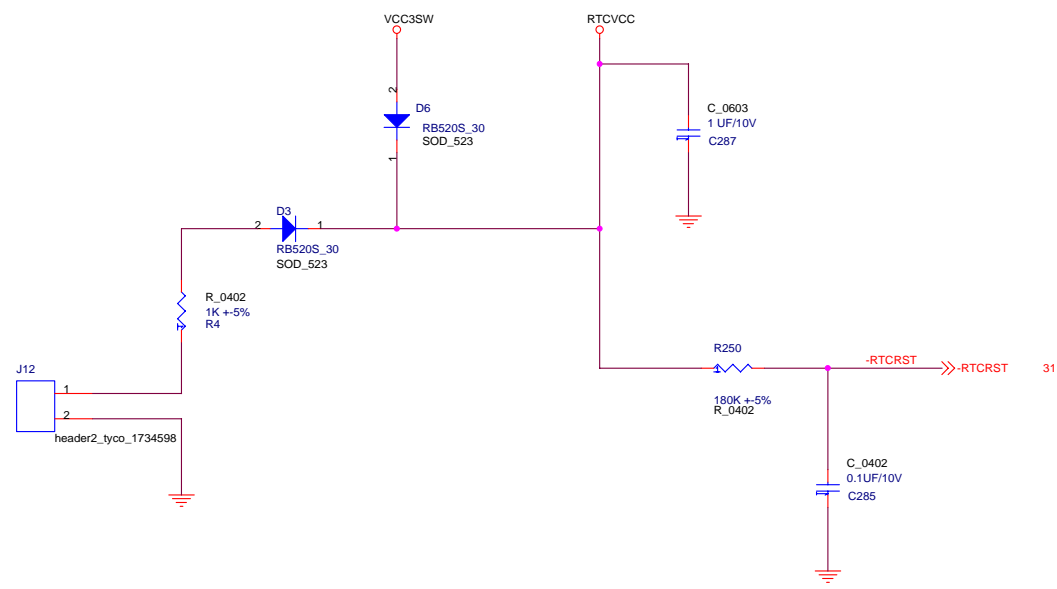

DESIGNER	J.CHEN	
CHECKED	Ogawa & OKU	
APPROVED	CHUJO	Part No. XXXXXX
CLASS	CHUJO	EC No. XXXXXX
THIS DOCUMENT IS THE PROPERTY OF LENOVO. ITS USE IS AUTHORIZED ONLY FOR RESPONDING TO A REQUEST FOR QUOTATION OR FOR THE PERFORMANCE OF WORK FOR LENOVO. ALL QUESTIONS MUST BE REFERRED TO THE LENOVO PURCHASING DEPARTMENT.		TITLE: Waikiki_1.1 Ver. V3.04
LENOVO CONFIDENTIAL		FWH,RTC BATTERY
		sheet 35 of 100 Wednesday, February 14, 2007

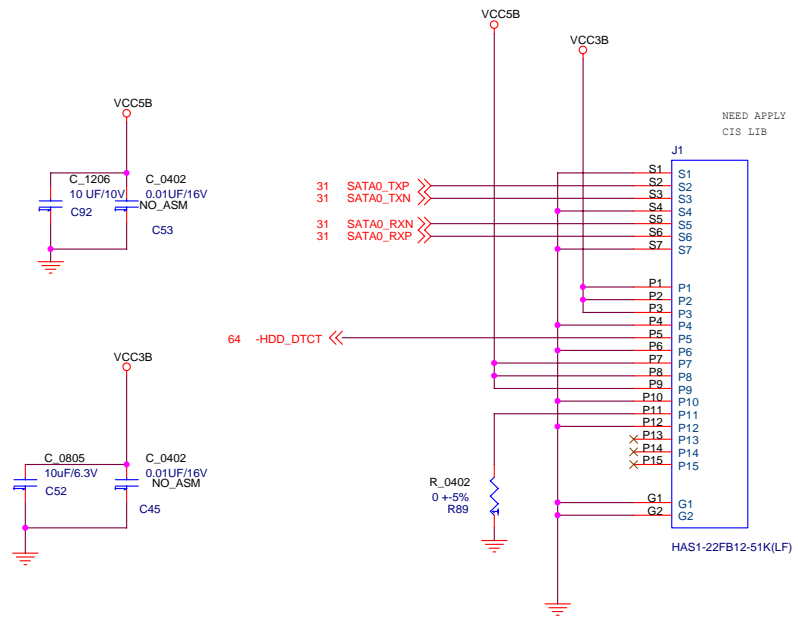

DESIGNER	J.CHEN	
CHECKED	Ogawa & OKU	
APPROVED	CHUJO	
CLASS	CHUJO	Part No . XXXXXX
THIS DOCUMENT IS THE PROPERTY OF LENOVO. ITS USE IS AUTHORIZED ONLY FOR RESPONDING TO A REQUEST FOR QUOTATION OR FOR THE PERFORMANCE OF WORK FOR LENOVO. ALL QUESTIONS MUST BE REFERRED TO THE LENOVO PURCHASING DEPARTMENT.		EC No . XXXXXX
LENOVO CONFIDENTIAL		TITLE: Waikiki_1.1 Ver. V3.04
		SATA HDD CONN
		sheet 36 of 100
		Wednesday, February 14, 2007

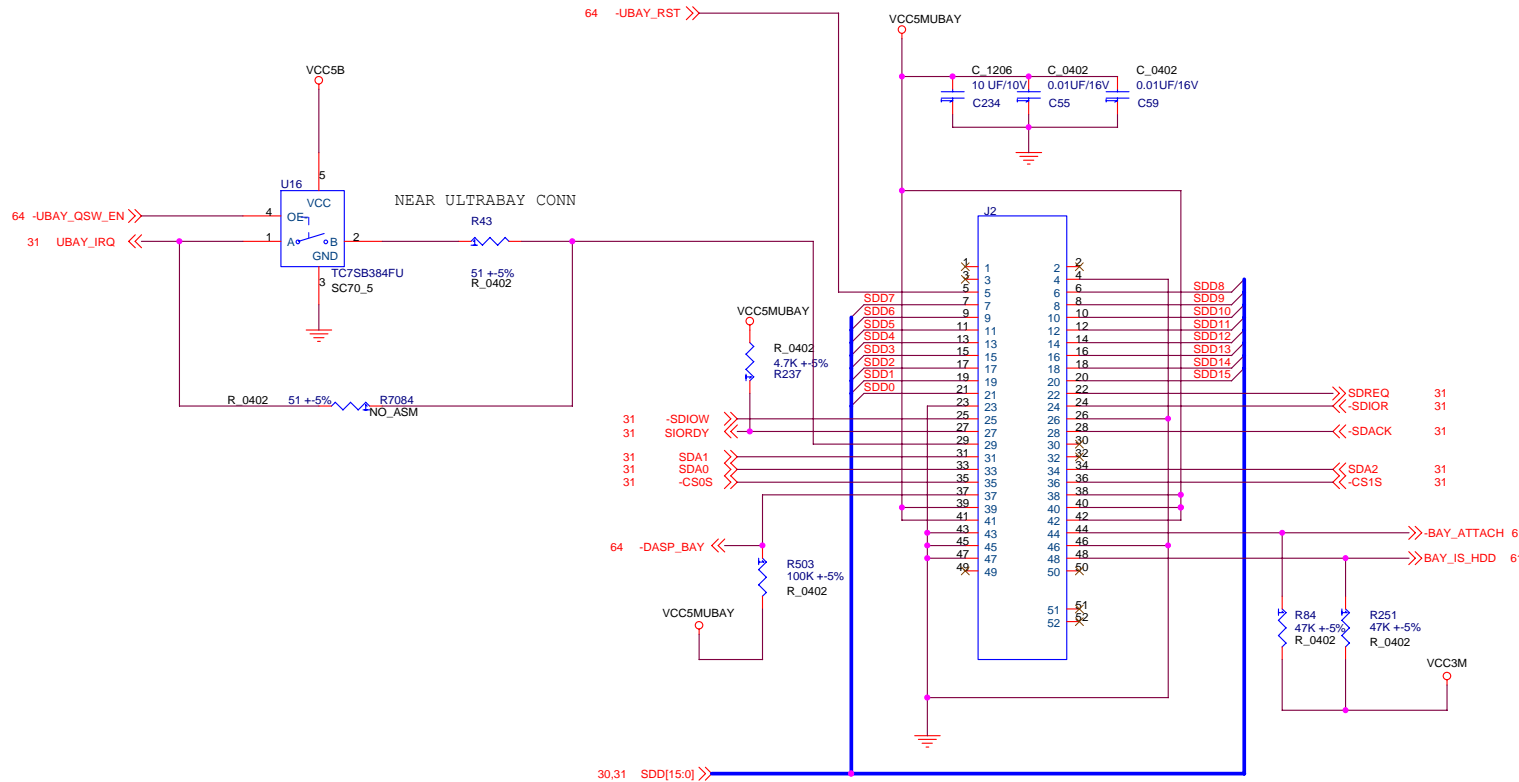

	SWAP BAY	FIXED BAY
U16	ASM	NO_ASM
R43	ASM	NO_ASM
R7084	NO_ASM	ASM

	-BAY_ATTACH	BAY_IS_HDD
NO DEVICE	H	DON'T CARE
OPTICAL	L	L
HDD	L	H

DESIGNER	J.CHEN	
CHECKED	Ogawa & OKU	
APPROVED	CHUJO	Part No. XXXXXX
CLASS	CHUJO	EC No. XXXXXX
THIS DOCUMENT IS THE PROPERTY OF LENOVO. ITS USE IS AUTHORIZED ONLY FOR RESPONDING TO A REQUEST FOR QUOTATION OR FOR THE PERFORMANCE OF WORK FOR LENOVO. ALL QUESTIONS MUST BE REFERRED TO THE LENOVO PURCHASING DEPARTMENT.		
TITLE: Waiki_1.1 Ver. V3.04		
BAY I/F CONN		
sheet 37 of 100		
Wednesday, February 14, 2007		
LENOVO CONFIDENTIAL		

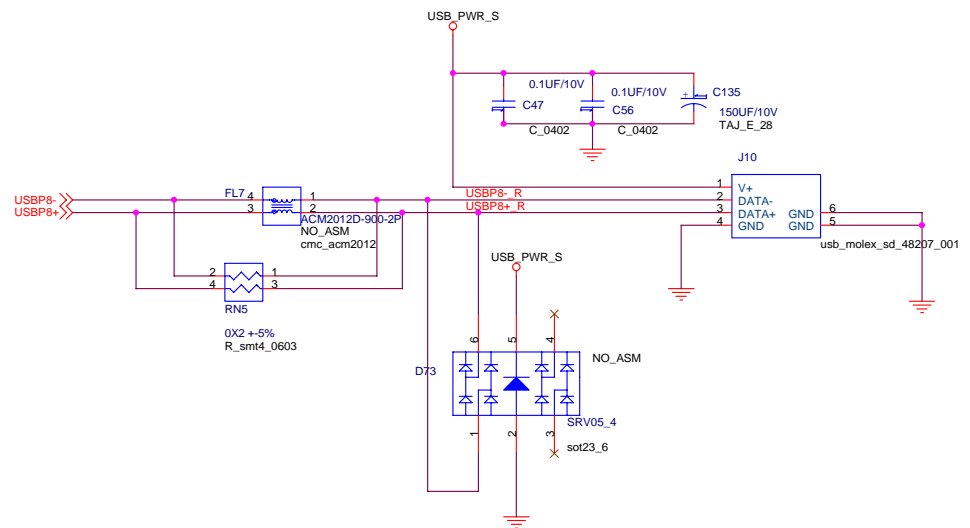
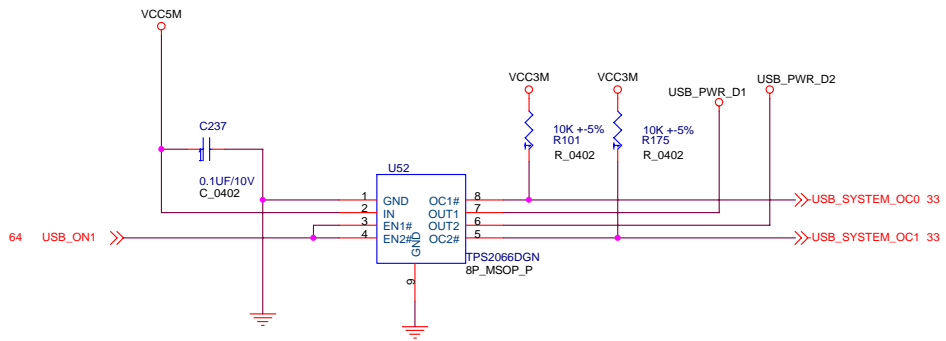
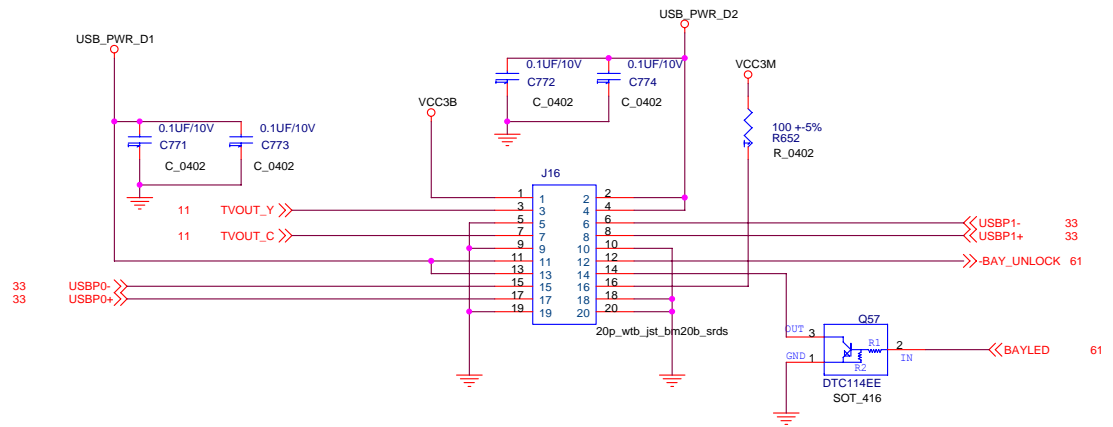
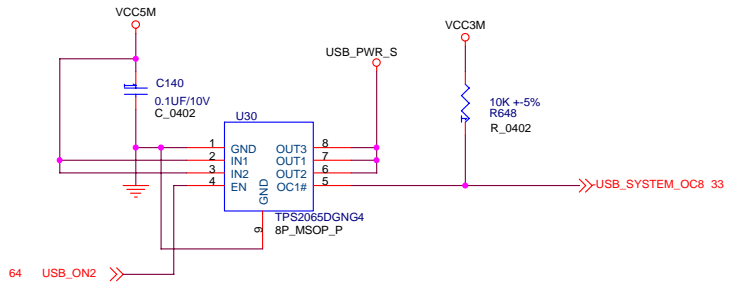

DESIGNER	J.CHEN	
CHECKED	Ogawa & OKU	
APPROVED	CHUJO	Part No. XXXXXX
CLASS	CHUJO	EC No. XXXXXX
THIS DOCUMENT IS THE PROPERTY OF LENOVO. ITS USE IS AUTHORIZED ONLY FOR RESPONDING TO A REQUEST FOR QUOTATION OR FOR THE PERFORMANCE OF WORK FOR LENOVO. ALL QUESTIONS MUST BE REFERRED TO THE LENOVO PURCHASING DEPARTMENT.		TITLE: Waikiki_1.1 Ver. V3.04
LENOVO CONFIDENTIAL		USB PWR/CONN
		sheet 38 of 100
		Wednesday, February 14, 2007

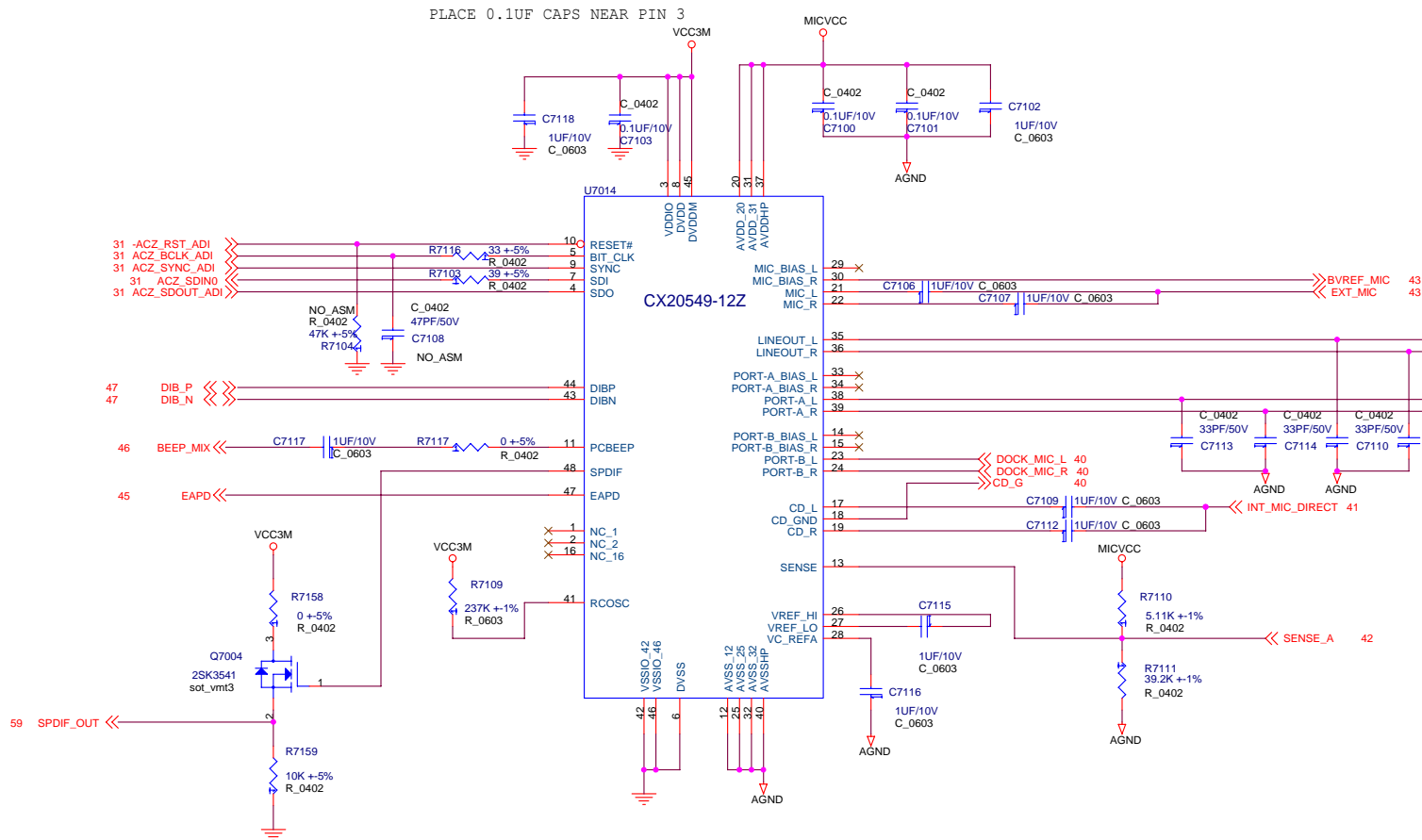

PLACE UNDER CX20549

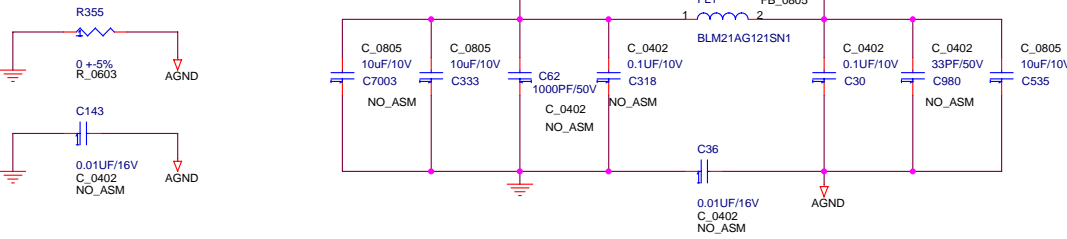

Assemble Option

	Wnote-1.1	Kona-1.1
R7158	ASM	NOASM
R7159	ASM	NOASM
Q7004	ASM	NOASM
Q89	ASM	NOASM (Page42)
R608	ASM	NOASM (Page42)
R225	ASM	NOASM (Page42)
R290	ASM	NOASM (Page42)
Q30	ASM	NOASM (Page42)
R49	ASM	NOASM (Page43)
R473	ASM	NOASM (Page43)
C283	ASM	NOASM (Page43)
C469	ASM	NOASM (Page43)
U11	ASM	NOASM (Page43)
R631	ASM	NOASM (Page45)
R632	ASM	NOASM (Page45)

DESIGNER	J.CHEN	
CHECKED	Ogawa & OKU	
APPROVED	CHUJO	Part No . XXXXXX
CLASS	CHUJO	EC No . XXXXXX
<small>THIS DOCUMENT IS THE PROPERTY OF LENOVO. ITS USE IS AUTHORIZED ONLY FOR RESPONDING TO A REQUEST FOR QUOTATION OR FOR THE PERFORMANCE OF WORK FOR LENOVO. ALL QUESTIONS MUST BE REFERRED TO THE LENOVO PURCHASING DEPARTMENT.</small>		
TITLE: Waikiki_1.1 Ver. V3.04		
AUDIO CODEC CX20549		
sheet 39 of 100		
Wednesday, February 14, 2007		
LENOVO CONFIDENTIAL		



CONTACT NEAR J3, INTERNAL
MICRPHONE PIN2

DESIGNER	J.CHEN	
CHECKED	Ogawa & OKU	
APPROVED	CHUJO	Part No . XXXXXX
CLASS	CHUJO	EC No . XXXXXX
<small>THIS DOCUMENT IS THE PROPERTY OF LENOVO. ITS USE IS AUTHORIZED ONLY FOR RESPONDING TO A REQUEST FOR QUOTATION OR FOR THE PERFORMANCE OF WORK FOR LENOVO. ALL QUESTIONS MUST BE REFERRED TO THE LENOVO PURCHASING DEPARTMENT.</small>		TITLE: Waikiki_1.1 Ver. V3.04
LENOVO CONFIDENTIAL		AUDIO MISC
		sheet 40 of 100 Wednesday, February 14, 2007

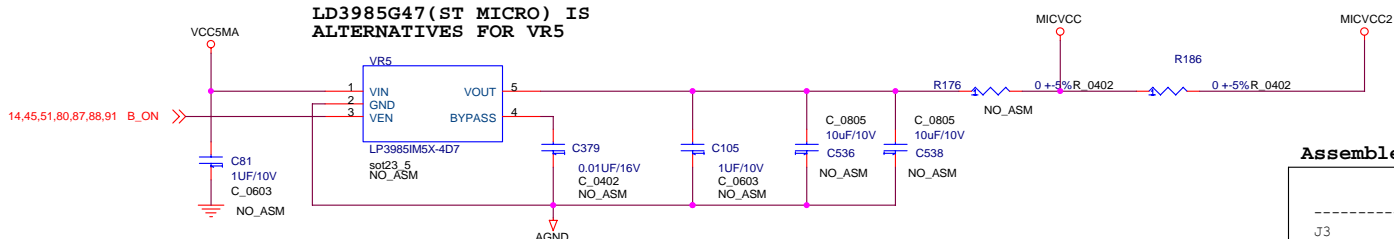

Assemble Option

	Wnote-1.1	Kona-1.1
J3	ASM	NOASM
U59	ASM	NOASM
L12	NOASM	NOASM
C147	ASM	NOASM
C144	ASM	NOASM
C139	ASM	NOASM
C593	ASM	NOASM
C588	ASM	NOASM
C7109	ASM	NOASM (page39)
C7112	ASM	NOASM (page39)
R105	ASM	NOASM
R38	ASM	NOASM
R40	ASM	NOASM
R340	ASM	NOASM
R326	ASM	NOASM
C7142	ASM	NOASM
C7143	ASM	NOASM
R7166	ASM	NOASM

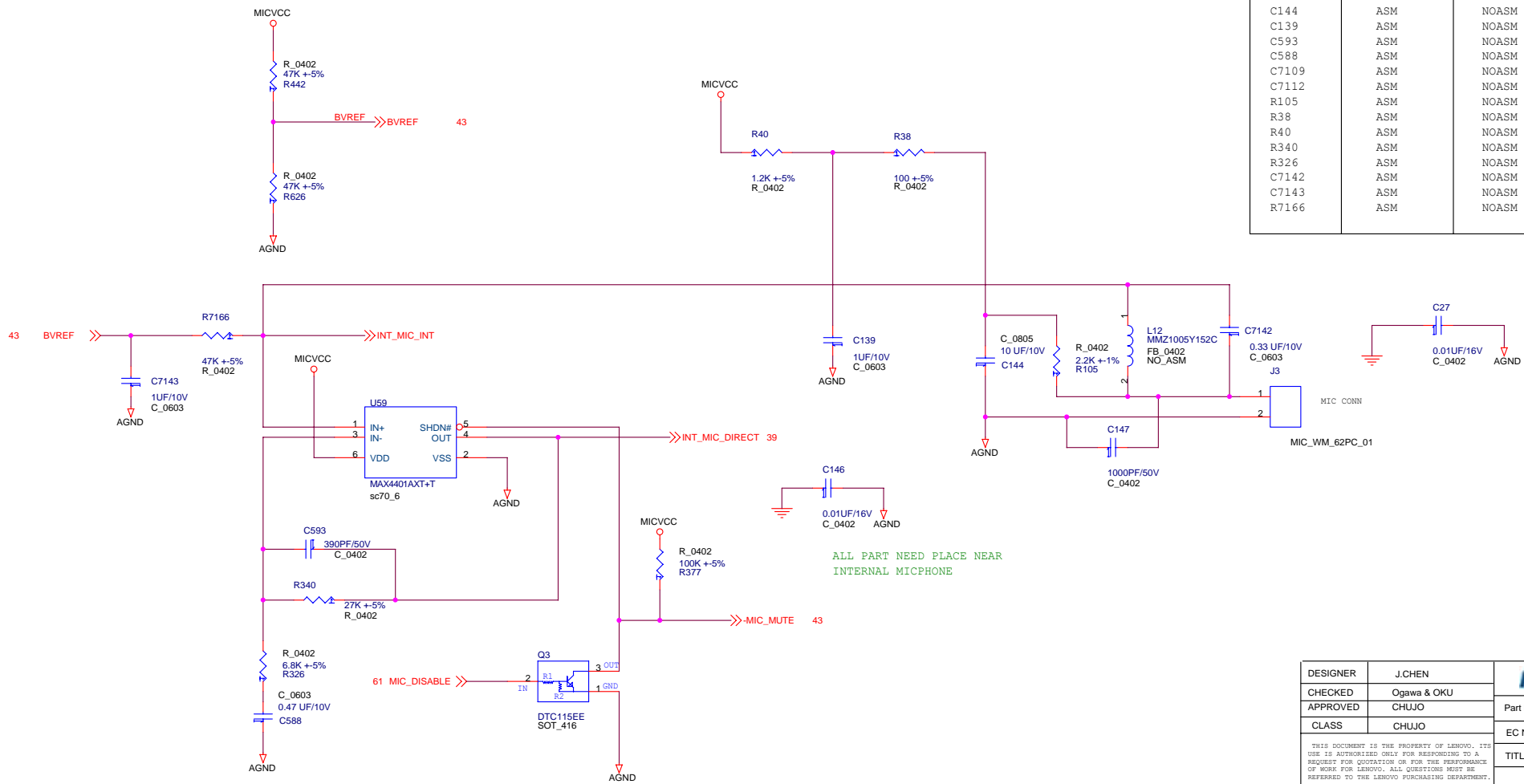

DESIGNER	J.CHEN	
CHECKED	Ogawa & OKU	
APPROVED	CHUJUO	Part No. XXXXXX
CLASS	CHUJUO	EC No. XXXXXX
THIS DOCUMENT IS THE PROPERTY OF LENOVO. ITS USE IS AUTHORIZED ONLY FOR RESPONDING TO A REQUEST FOR QUOTATION OR FOR THE PERFORMANCE OF WORK FOR LENOVO. ALL QUESTIONS MUST BE REFERRED TO THE LENOVO PURCHASING DEPARTMENT.		TITLE: Waikiki_1.1 Ver. V3.04
LENOVO CONFIDENTIAL		AUDIO INT MIC
		sheet 41 of 100
		Wednesday, February 14, 2007

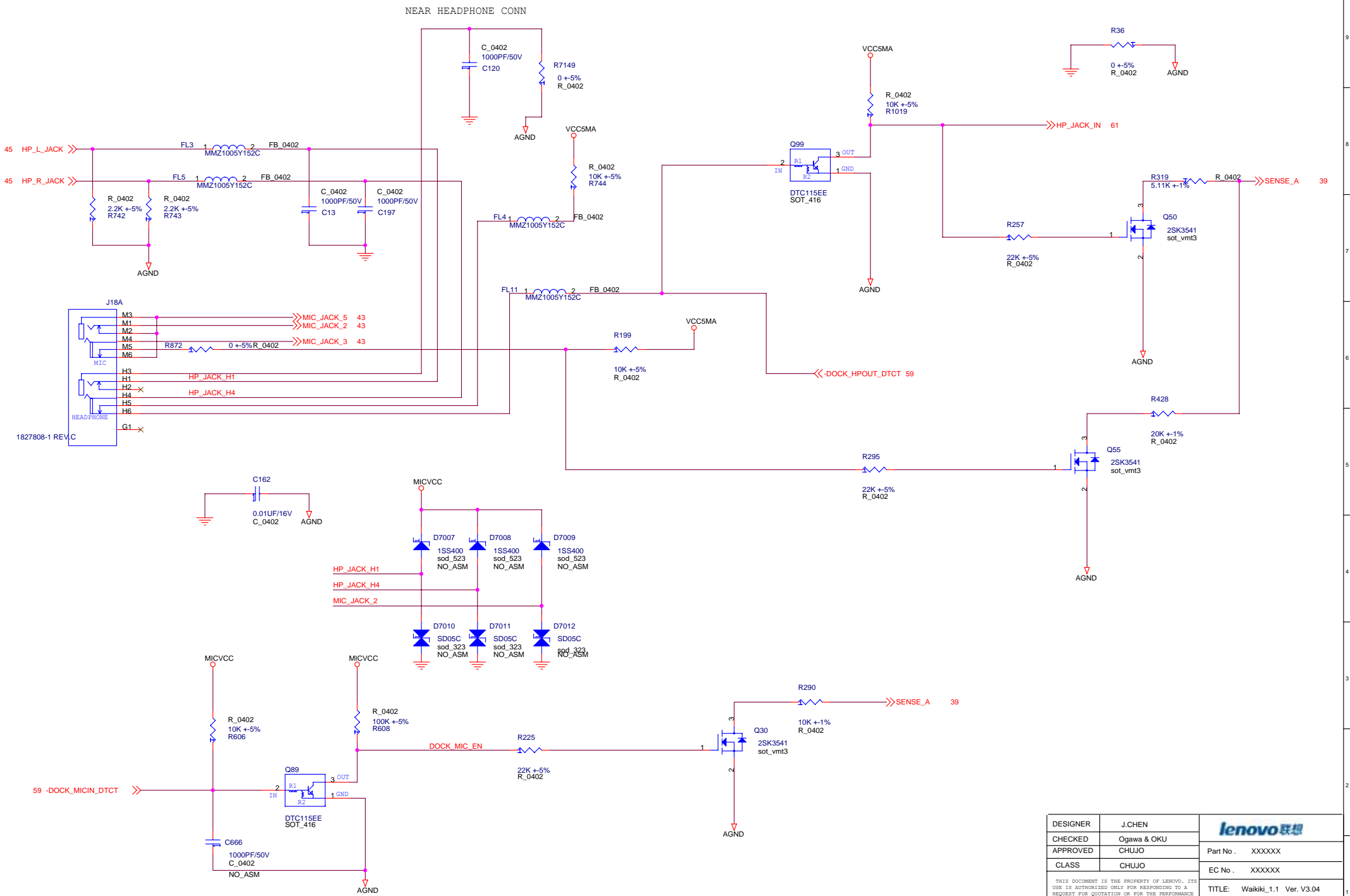

DESIGNER	J.CHEN	
CHECKED	Ogawa & OKU	
APPROVED	CHUJUO	Part No . XXXXXX
CLASS	CHUJUO	EC No . XXXXXX
<small>THIS DOCUMENT IS THE PROPERTY OF LENOVO. ITS USE IS AUTHORIZED ONLY FOR RESPONDING TO A REQUEST FOR QUOTATION OR FOR THE PERFORMANCE OF WORK FOR LENOVO. ALL QUESTIONS MUST BE REFERRED TO THE LENOVO PURCHASING DEPARTMENT.</small>		TITLE: Waikiki_1.1 Ver. V3.04
LENOVO CONFIDENTIAL		EXT MIC JACK
		sheet 42 of 100
		Wednesday, February 14, 2007

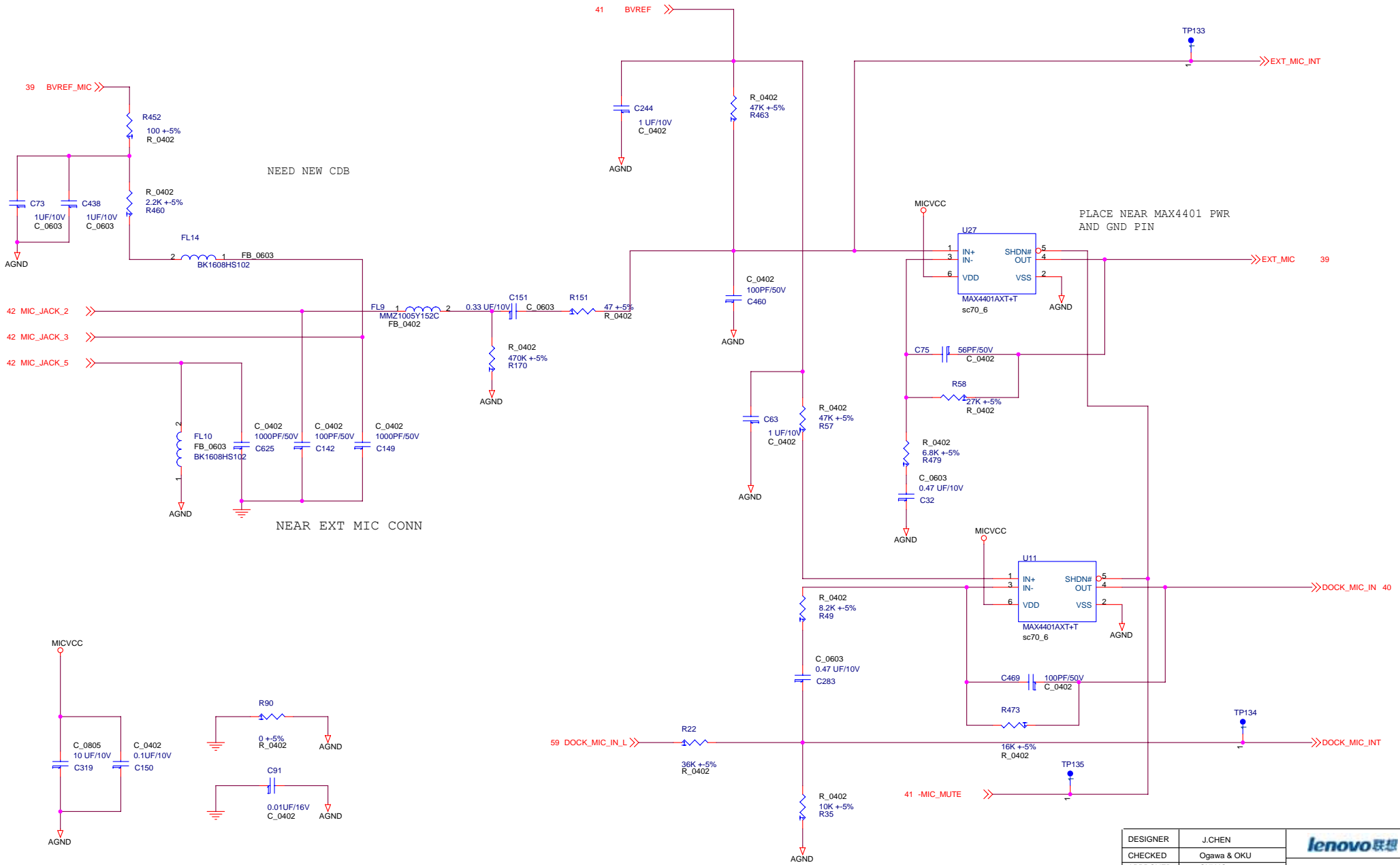

DESIGNER	J.CHEN	
CHECKED	Ogawa & OKU	
APPROVED	CHUJO	Part No. XXXXXX
CLASS	CHUJO	EC No. XXXXXX
<small>THIS DOCUMENT IS THE PROPERTY OF LENOVO. ITS USE IS AUTHORIZED ONLY FOR RESPONDING TO A REQUEST FOR QUOTATION OR FOR THE PERFORMANCE OF WORK FOR LENOVO. ALL QUESTIONS MUST BE REFERRED TO THE LENOVO PURCHASING DEPARTMENT.</small>		TITLE: Waiki_1.1 Ver. V3.04
LENOVO CONFIDENTIAL		AUDIO EXT MIC AMP
		sheet 43 of 100
		Wednesday, February 14, 2007

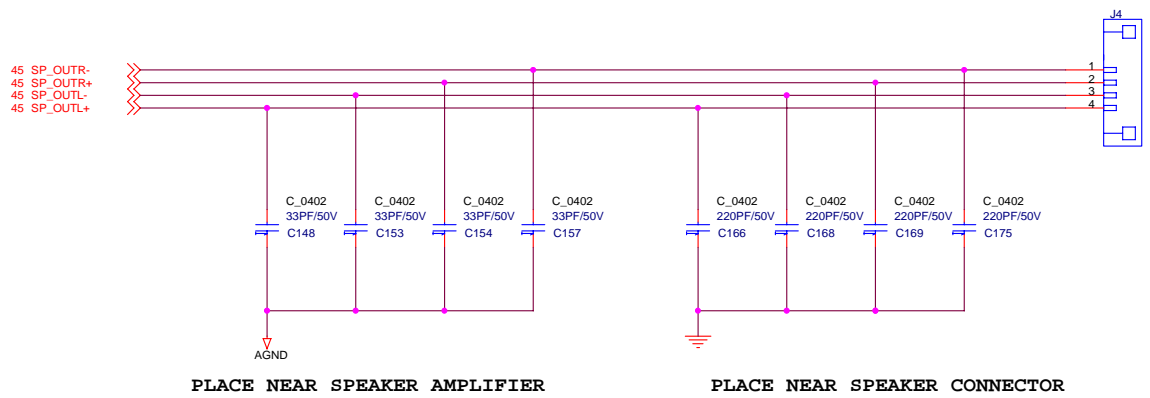

DESIGNER	J.CHEN	
CHECKED	Ogawa & OKU	
APPROVED	CHUJO	Part No . XXXXXX
CLASS	CHUJO	EC No . XXXXXX
<small>THIS DOCUMENT IS THE PROPERTY OF LENOVO. ITS USE IS AUTHORIZED ONLY FOR RESPONDING TO A REQUEST FOR QUOTATION OR FOR THE PERFORMANCE OF WORK FOR LENOVO. ALL QUESTIONS MUST BE REFERRED TO THE LENOVO PURCHASING DEPARTMENT.</small>		TITLE: Waikiki_1.1 Ver. V3.04
LENOVO CONFIDENTIAL		AUDIO SPEAKER
		sheet 44 of 100 Wednesday, February 14, 2007

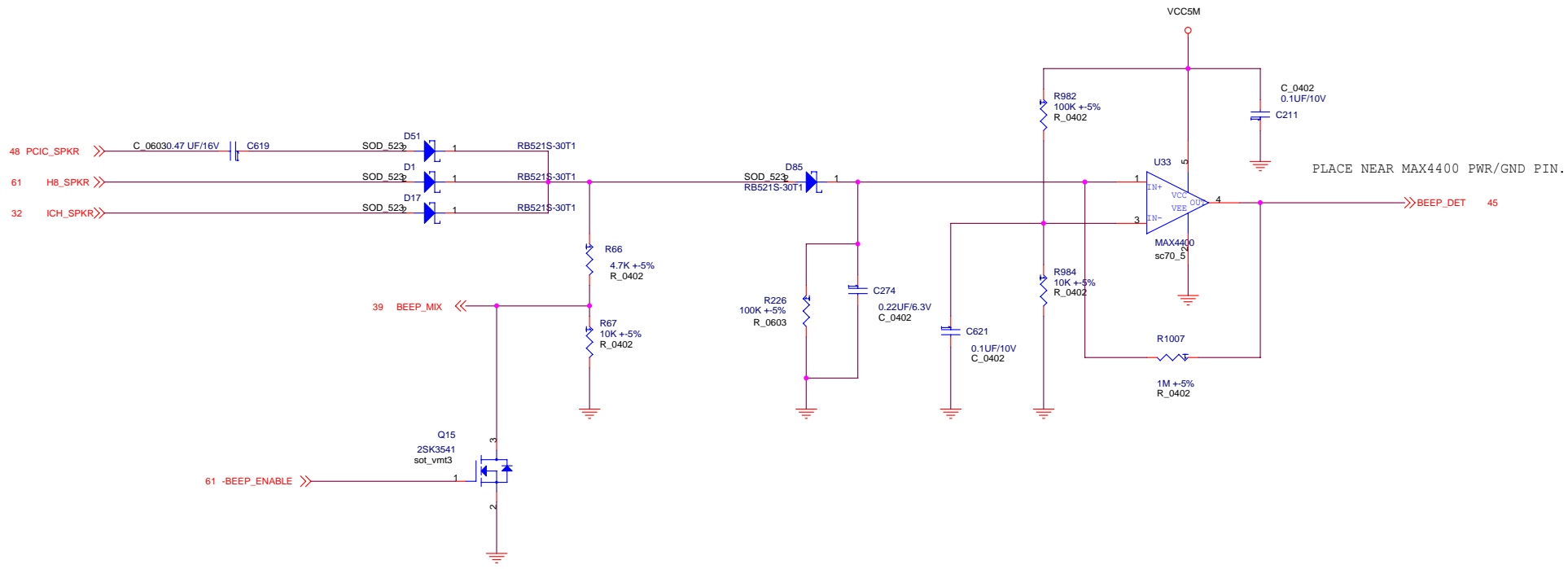

PLACE NEAR MAX4400 PWR/GND PIN.

DESIGNER	J.CHEN	
CHECKED	Ogawa & OKU	
APPROVED	CHUJO	Part No. XXXXXX
CLASS	CHUJO	EC No. XXXXXX
<small>THIS DOCUMENT IS THE PROPERTY OF LENOVO. ITS USE IS AUTHORIZED ONLY FOR RESPONDING TO A REQUEST FOR QUOTATION OR FOR THE PERFORMANCE OF WORK FOR LENOVO. ALL QUESTIONS MUST BE REFERRED TO THE LENOVO PURCHASING DEPARTMENT.</small>		TITLE: Waikiki_1.1 Ver. V3.04
LENOVO CONFIDENTIAL		AUDIO HDP BEEP
		sheet 46 of 100 Wednesday, February 14, 2007

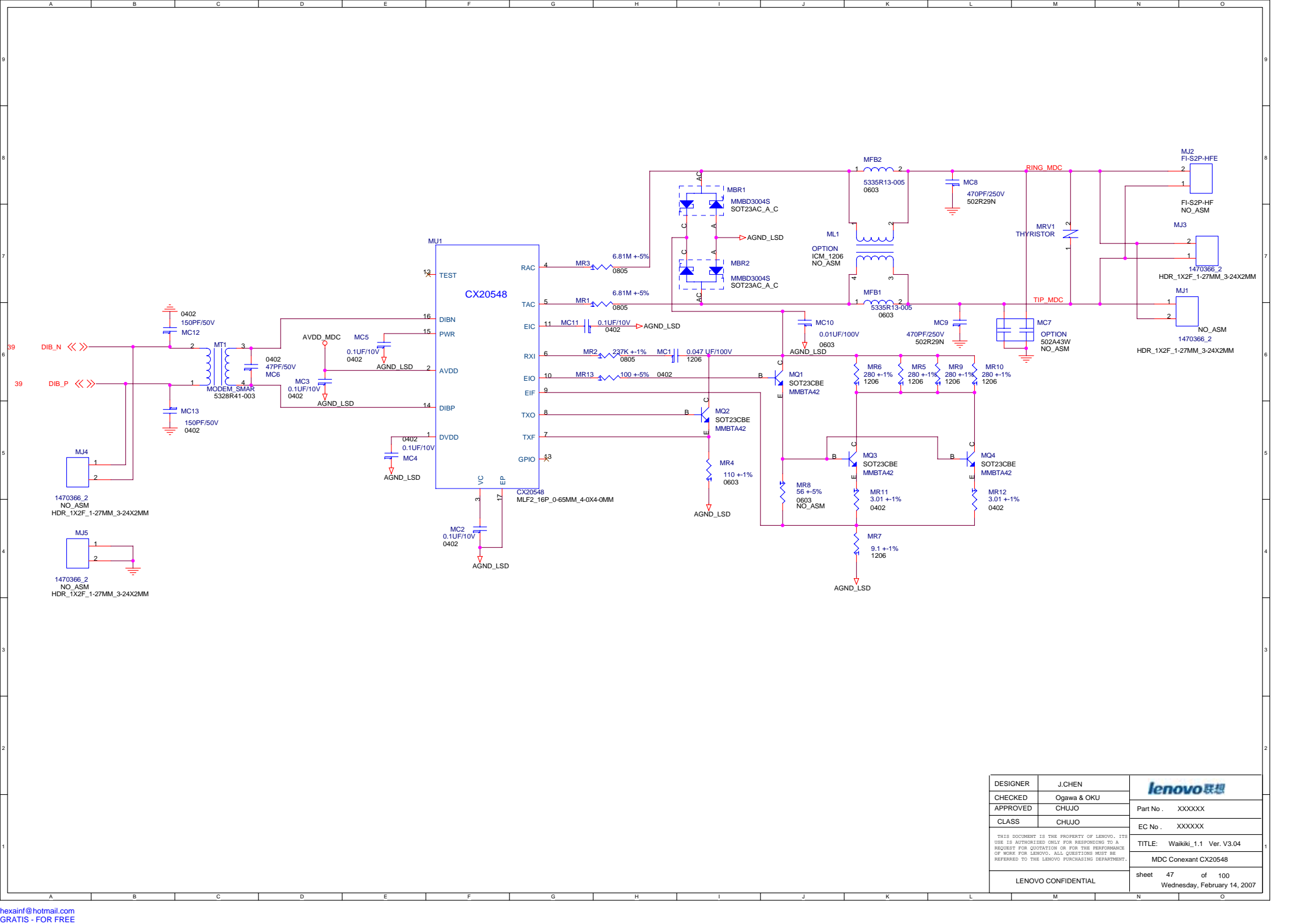

DESIGNER	J.CHEN	
CHECKED	Ogawa & OKU	
APPROVED	CHUJO	Part No. XXXXXX
CLASS	CHUJO	EC No. XXXXXX
THIS DOCUMENT IS THE PROPERTY OF LENOVO. ITS USE IS AUTHORIZED ONLY FOR RESPONDING TO A REQUEST FOR QUOTATION OR FOR THE PERFORMANCE OF WORK FOR LENOVO. ALL QUESTIONS MUST BE REFERRED TO THE LENOVO PURCHASING DEPARTMENT.		TITLE: Waikiki_1.1 Ver. V3.04
LENOVO CONFIDENTIAL		MDC Conexant CX20548
		sheet 47 of 100 Wednesday, February 14, 2007

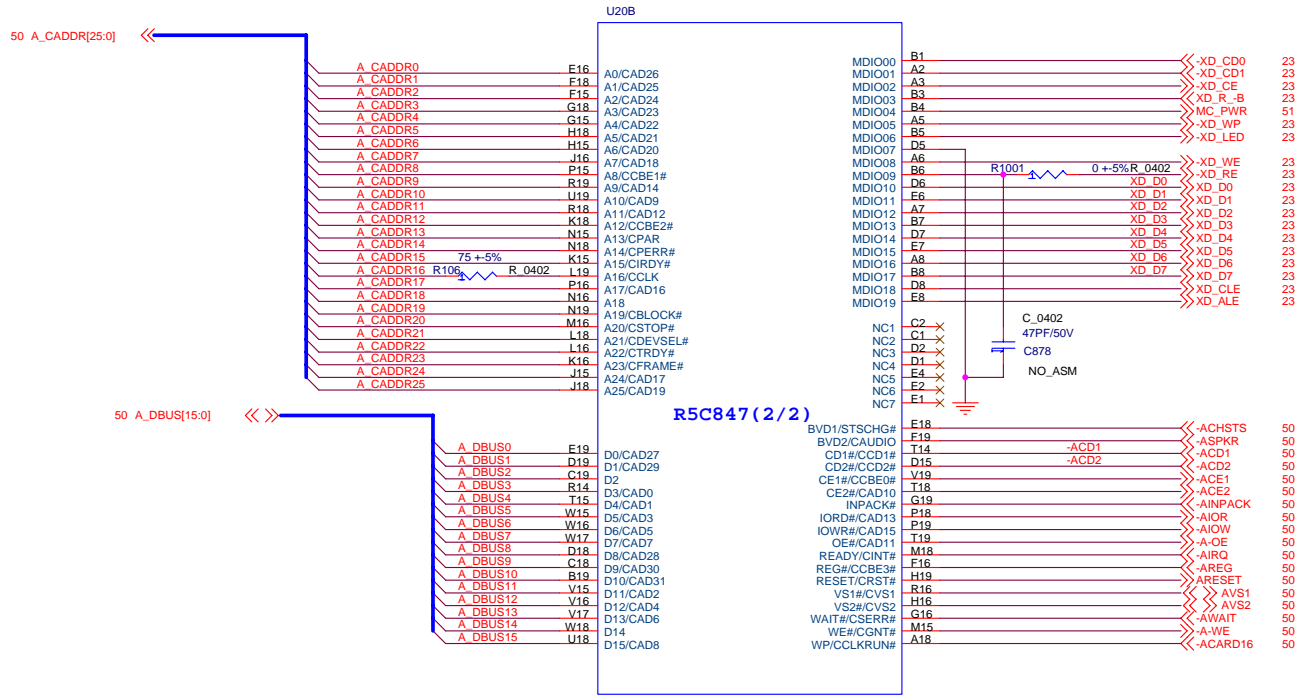

R5C847-CSP208Q
208p_bga_16x16

DESIGNER	J.CHEN	
CHECKED	Ogawa & OKU	
APPROVED	CHUJO	Part No. XXXXXX
CLASS	CHUJO	EC No. XXXXXX
<small>THIS DOCUMENT IS THE PROPERTY OF LENOVO. ITS USE IS AUTHORIZED ONLY FOR RESPONDING TO A REQUEST FOR QUOTATION OR FOR THE PERFORMANCE OF WORK FOR LENOVO. ALL QUESTIONS MUST BE REFERRED TO THE LENOVO PURCHASING DEPARTMENT.</small>		TITLE: Waikiki_1.1 Ver. V3.04
LENOVO CONFIDENTIAL		CARD BUS CONTROLLER(2/2)
		sheet 49 of 100 Wednesday, February 14, 2007

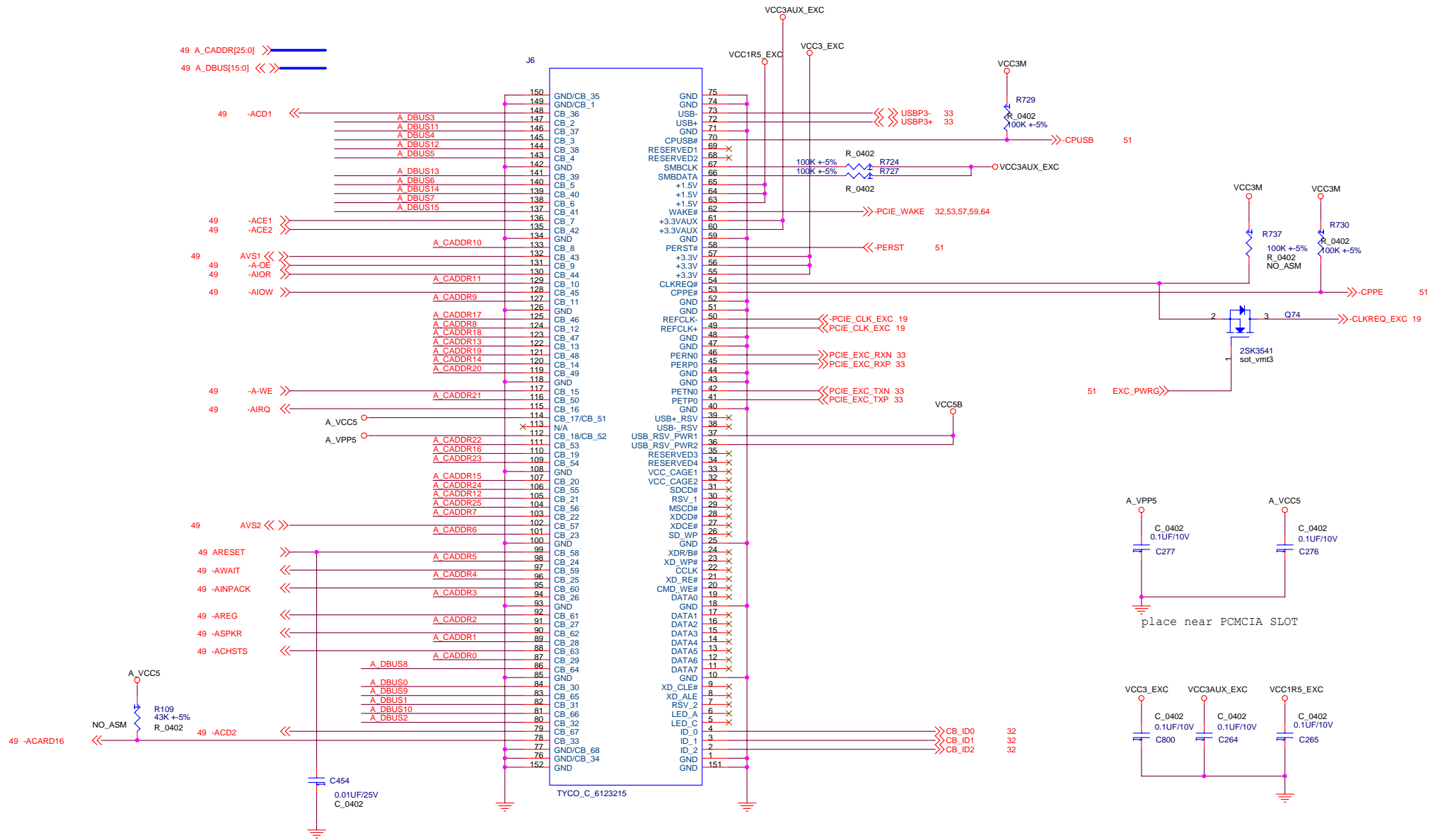

place near PCMCIA SLOT

DESIGNER	J.CHEN	
CHECKED	Ogawa & OKU	
APPROVED	CHUJO	Part No . XXXXXX
CLASS	CHUJO	EC No . XXXXXX
THIS DOCUMENT IS THE PROPERTY OF LENOVO. ITS USE IS AUTHORIZED ONLY FOR RESPONDING TO A REQUEST FOR QUOTATION OR FOR THE PERFORMANCE OF WORK FOR LENOVO. ALL QUESTIONS MUST BE REFERRED TO THE LENOVO PURCHASING DEPARTMENT.		TITLE: Waikiki_1.1 Ver. V3.04
LENOVO CONFIDENTIAL		CARDBUS SLOT
		sheet 50 of 100
		Wednesday, February 14, 2007

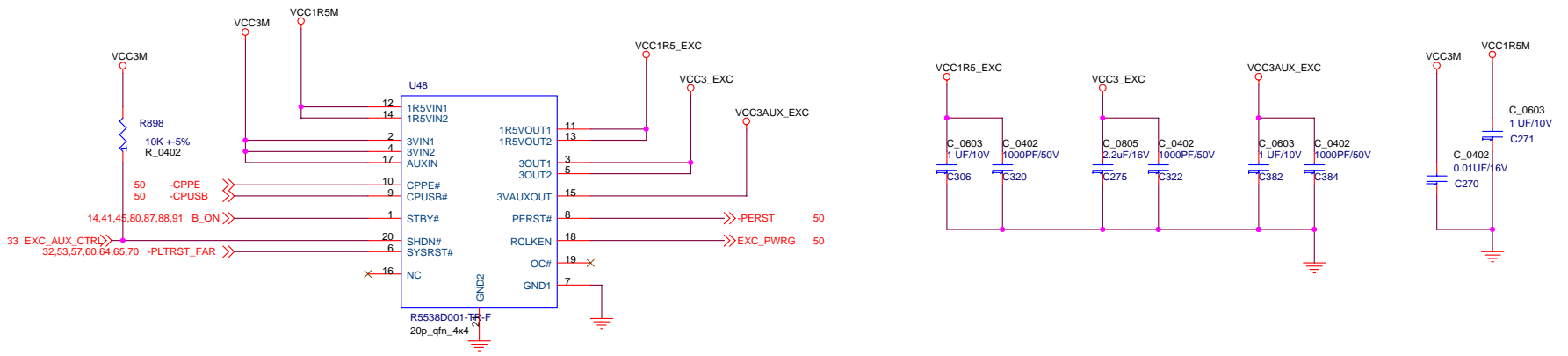
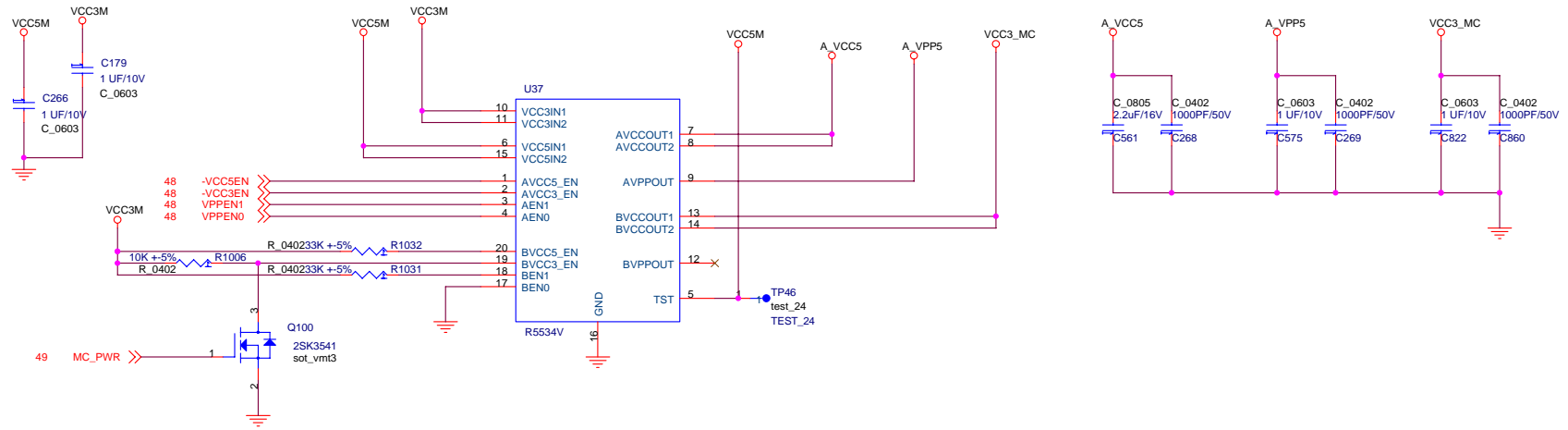

DESIGNER	J.CHEN	
CHECKED	Ogawa & OKU	
APPROVED	CHUJO	Part No. XXXXXX
CLASS	CHUJO	EC No. XXXXXX
<small>THIS DOCUMENT IS THE PROPERTY OF LENOVO. ITS USE IS AUTHORIZED ONLY FOR RESPONDING TO A REQUEST FOR QUOTATION OR FOR THE PERFORMANCE OF WORK FOR LENOVO. ALL QUESTIONS MUST BE REFERRED TO THE LENOVO PURCHASING DEPARTMENT.</small>		TITLE: Waikiki_1.1 Ver. V3.04
LENOVO CONFIDENTIAL		CARDBUS PWR CONTROL
		sheet 51 of 100 Wednesday, February 14, 2007

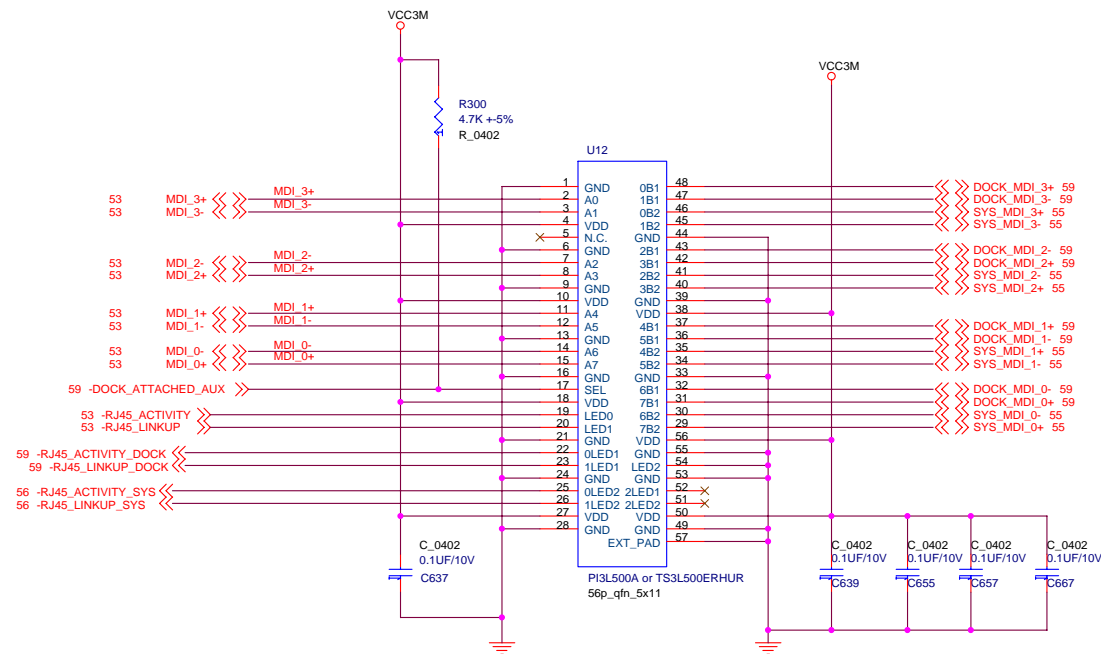

	DOCK	NO DOCK
U12	ASM	NO_ASM
C639	ASM	NO_ASM
C655	ASM	NO_ASM
C667	ASM	NO_ASM
R300	ASM	NO_ASM
RN701	NO_ASM	ASM
RN702	NO_ASM	ASM
RN703	NO_ASM	ASM
RN704	NO_ASM	ASM
RN705	NO_ASM	ASM
C637	ASM	NO_ASM

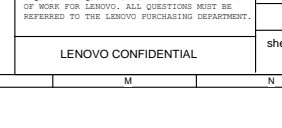
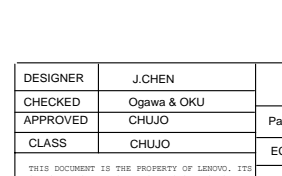
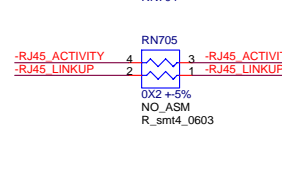
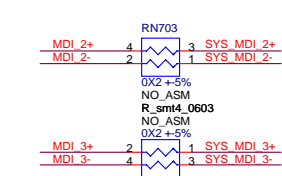
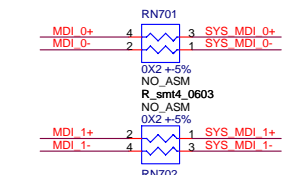

DESIGNER	J.CHEN	
CHECKED	Ogawa & OKU	
APPROVED	CHUJO	Part No. XXXXXX
CLASS	CHUJO	EC No. XXXXXX
<small>THIS DOCUMENT IS THE PROPERTY OF LENOVO. ITS USE IS AUTHORIZED ONLY FOR RESPONDING TO A REQUEST FOR QUOTATION OR FOR THE PERFORMANCE OF WORK FOR LENOVO. ALL QUESTIONS MUST BE REFERRED TO THE LENOVO PURCHASING DEPARTMENT.</small>		TITLE: Waikiki_1.1 Ver. V3.04
LENOVO CONFIDENTIAL		sheet 52 of 100 Wednesday, February 14, 2007

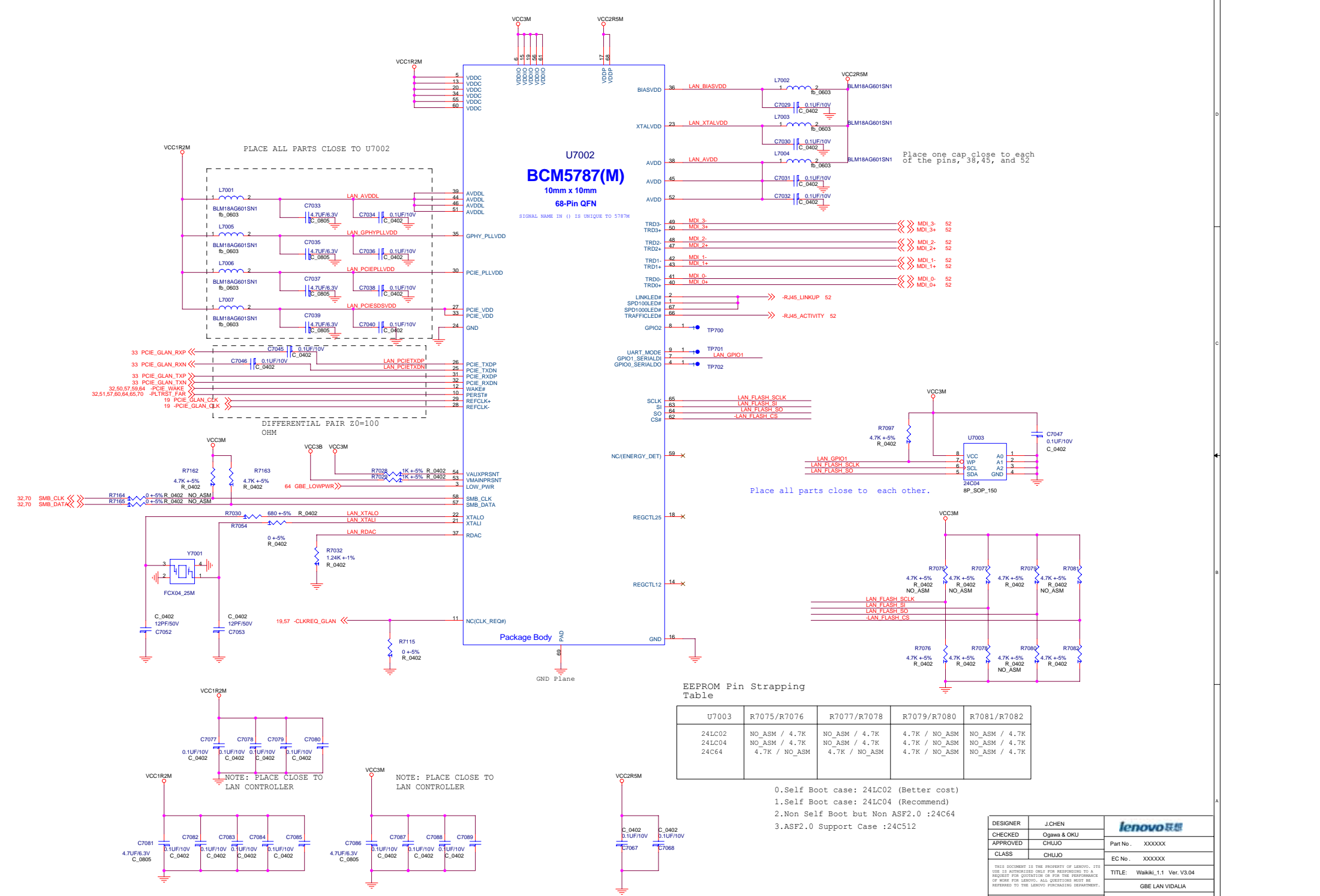

U7002
BCM5787(M)
 10mm x 10mm
 68-Pin QFN

SIGNAL NAME IN () IS UNIQUE TO 5787M

Place one cap close to each of the pins, 38, 48, and 52

Place all parts close to each other.

EEPROM Pin Strapping Table

U7003	R7075/R7076	R7077/R7078	R7079/R7080	R7081/R7082
24LC02	NO_ASM / 4.7K	NO_ASM / 4.7K	4.7K / NO_ASM	NO_ASM / 4.7K
24LC04	NO_ASM / 4.7K	NO_ASM / 4.7K	4.7K / NO_ASM	NO_ASM / 4.7K
24C64	4.7K / NO_ASM	4.7K / NO_ASM	4.7K / NO_ASM	NO_ASM / 4.7K

0. Self Boot case: 24LC02 (Better cost)
1. Self Boot case: 24LC04 (Recommend)
2. Non Self Boot but Non ASF2.0 : 24C64
3. ASF2.0 Support Case : 24C512

DESIGNER	J.CHEN	
CHECKED	Ogawa & OKU	
APPROVED	CHUJO	Part No. XXXXXX
CLASS	CHUJO	EC No. XXXXXX
<small>THIS DOCUMENT IS THE PROPERTY OF LENOVO. ITS USE IS AUTHORIZED ONLY FOR RESPONDING TO A REQUEST FOR QUOTATION OR FOR THE PERFORMANCE OF WORK FOR LENOVO. ALL QUESTIONS MUST BE REFERRED TO THE LENOVO FORWARDING DEPARTMENT.</small>		
TITLE: Waikui_1.1 Ver. V3.04		
GBE LAN VIDALIA		
sheet 53 of 100 Wednesday, February 14, 2007		

BLANK

DESIGNER	J.CHEN	
CHECKED	Ogawa & OKU	
APPROVED	CHUJO	Part No . XXXXXX
CLASS	CHUJO	EC No . XXXXXX
<small>THIS DOCUMENT IS THE PROPERTY OF LENOVO. ITS USE IS AUTHORIZED ONLY FOR RESPONDING TO A REQUEST FOR QUOTATION OR FOR THE PERFORMANCE OF WORK FOR LENOVO. ALL QUESTIONS MUST BE REFERRED TO THE LENOVO PURCHASING DEPARTMENT.</small>		TITLE: Waikiki_1.1 Ver. V3.04
LENOVO CONFIDENTIAL		MICRO PCIE CONN
		sheet 54 of 100 Wednesday, February 14, 2007

	DOCK	NO DOCK
F13	ASM	NO_ASM

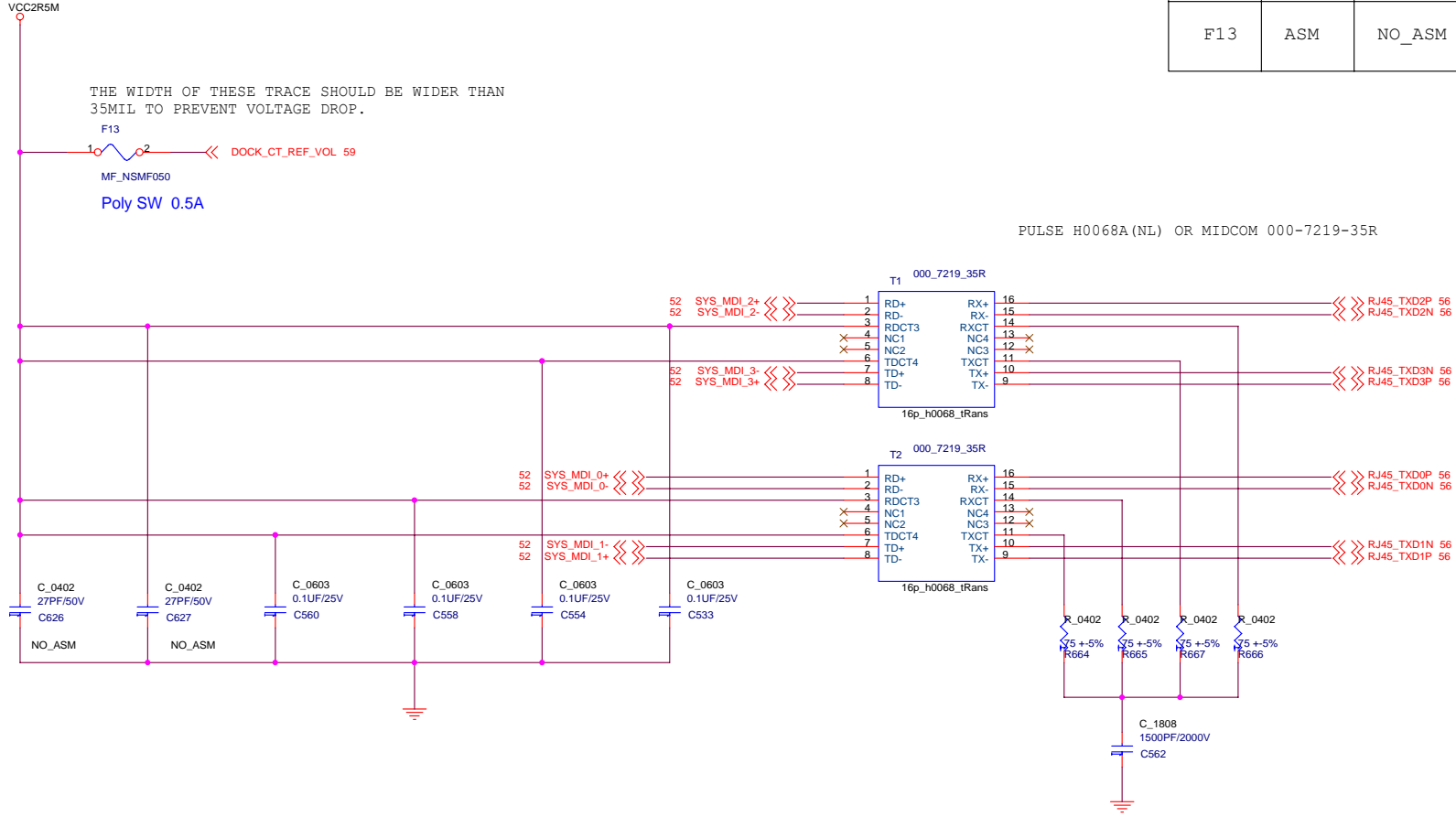

DESIGNER	J.CHEN	
CHECKED	Ogawa & OKU	
APPROVED	CHUJO	Part No. XXXXXX
CLASS	CHUJO	EC No. XXXXXX
THIS DOCUMENT IS THE PROPERTY OF LENOVO. ITS USE IS AUTHORIZED ONLY FOR RESPONDING TO A REQUEST FOR QUOTATION OR FOR THE PERFORMANCE OF WORK FOR LENOVO. ALL QUESTIONS MUST BE REFERRED TO THE LENOVO PURCHASING DEPARTMENT.		TITLE: Waikiki_1.1 Ver. V3.04
LENOVO CONFIDENTIAL		GBE MAGNETICS
		sheet 55 of 100 Wednesday, February 14, 2007

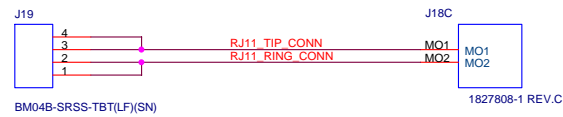
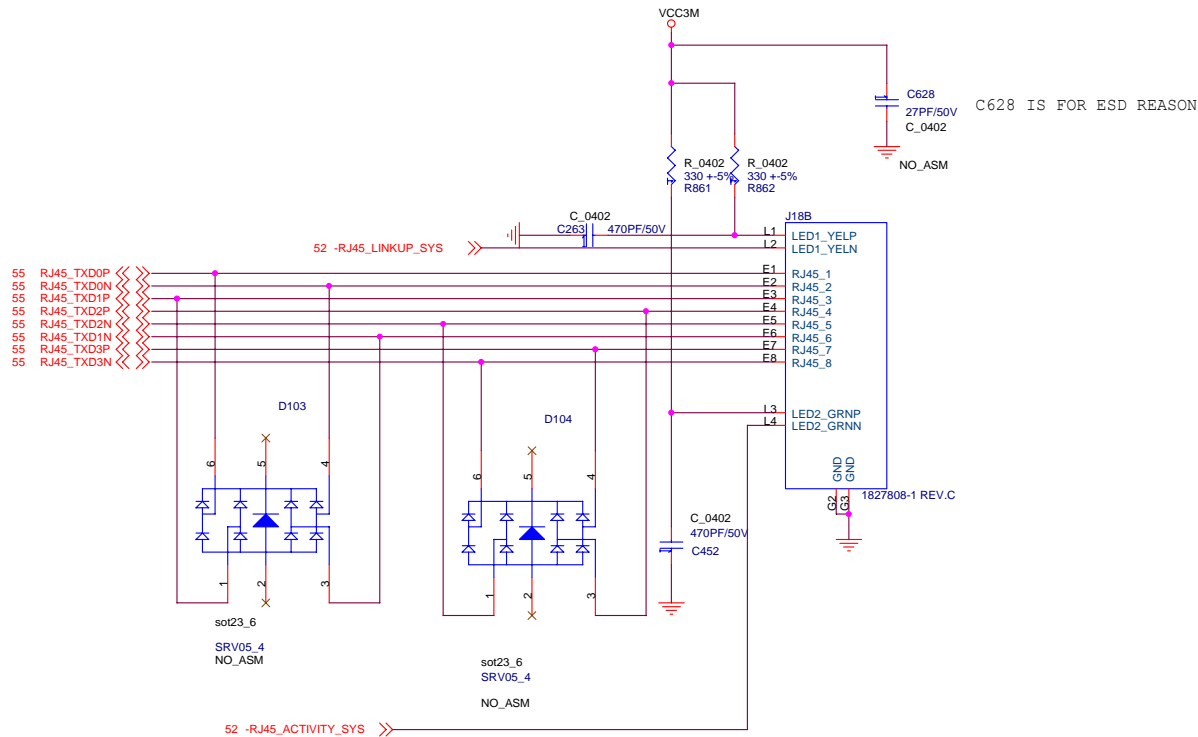

	DOCK	NO DOCK
J11	ASM	NO_ASM

DESIGNER	J.CHEN	
CHECKED	Ogawa & OKU	
APPROVED	CHUJO	Part No . XXXXXX
CLASS	CHUJO	EC No . XXXXXX
<small>THIS DOCUMENT IS THE PROPERTY OF LENOVO. ITS USE IS AUTHORIZED ONLY FOR RESPONDING TO A REQUEST FOR QUOTATION OR FOR THE PERFORMANCE OF WORK FOR LENOVO. ALL QUESTIONS MUST BE REFERRED TO THE LENOVO PURCHASING DEPARTMENT.</small>		TITLE: Waikiki_1.1 Ver. V3.04
LENOVO CONFIDENTIAL		RJ45 CONN
		sheet 56 of 100 Wednesday, February 14, 2007

	W/WLAN	W/O WLAN
J22	ASM	NO_ASM
J25	ASM	NO_ASM

MINI PCIE CONN-1 FOR WWAN

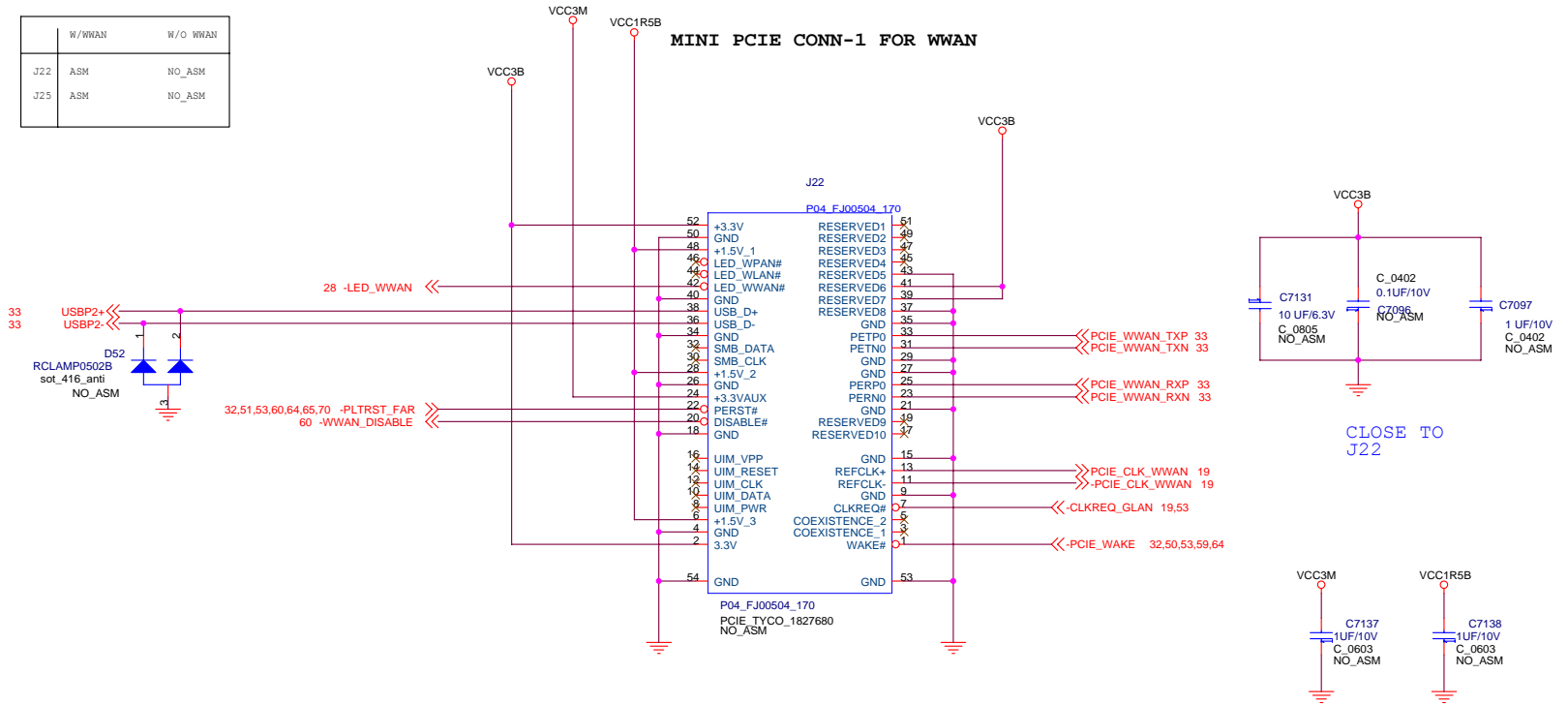

MINI PCIE CONN-2 FOR WLAN

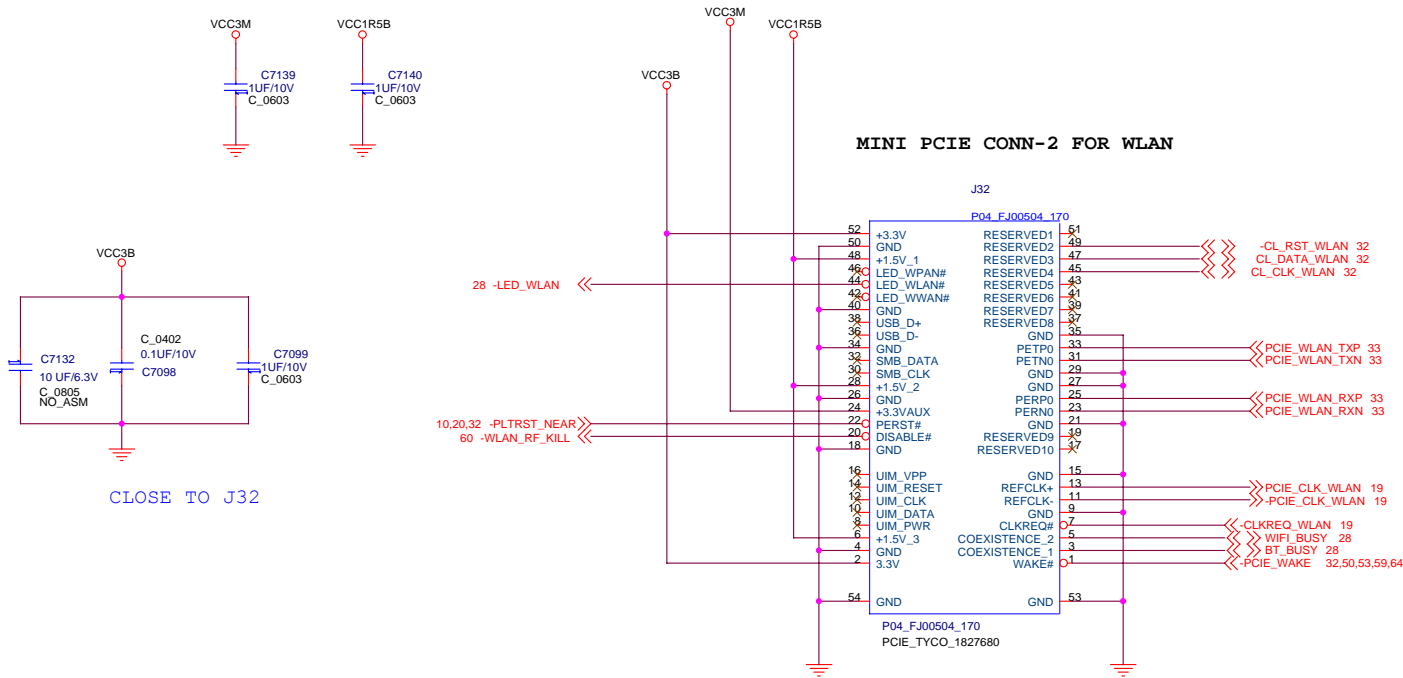

DESIGNER	J.CHEN	
CHECKED	Ogawa & OKU	
APPROVED	CHUJO	Part No. XXXXXX
CLASS	CHUJO	EC No. XXXXXX
<small>THIS DOCUMENT IS THE PROPERTY OF LENOVO. ITS USE IS AUTHORIZED ONLY FOR RESPONDING TO A REQUEST FOR QUOTATION OR FOR THE PERFORMANCE OF WORK FOR LENOVO. ALL QUESTIONS MUST BE REFERRED TO THE LENOVO PURCHASING DEPARTMENT.</small>		TITLE: Waikiki_1.1 Ver. V3.04
LENOVO CONFIDENTIAL		MINI PCIE SLOT(WWAN/WLAN)
		sheet 57 of 100 Wednesday, February 14, 2007

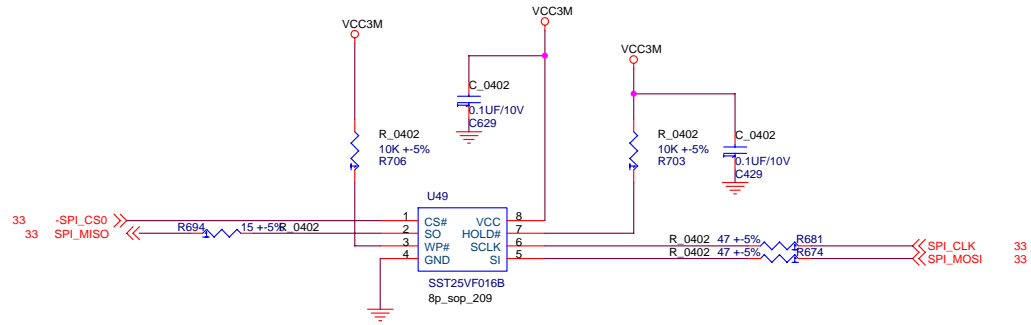

DESIGNER	J.CHEN	
CHECKED	Ogawa & OKU	
APPROVED	CHUJO	Part No. XXXXXX
CLASS	CHUJO	EC No. XXXXXX
<small>THIS DOCUMENT IS THE PROPERTY OF LENOVO. ITS USE IS AUTHORIZED ONLY FOR RESPONDING TO A REQUEST FOR QUOTATION OR FOR THE PERFORMANCE OF WORK FOR LENOVO. ALL QUESTIONS MUST BE REFERRED TO THE LENOVO PURCHASING DEPARTMENT.</small>		TITLE: Waikiki_1.1 Ver. V3.04
LENOVO CONFIDENTIAL		EEPROM/FLASH/SHARED
		sheet 58 of 100 Wednesday, February 14, 2007

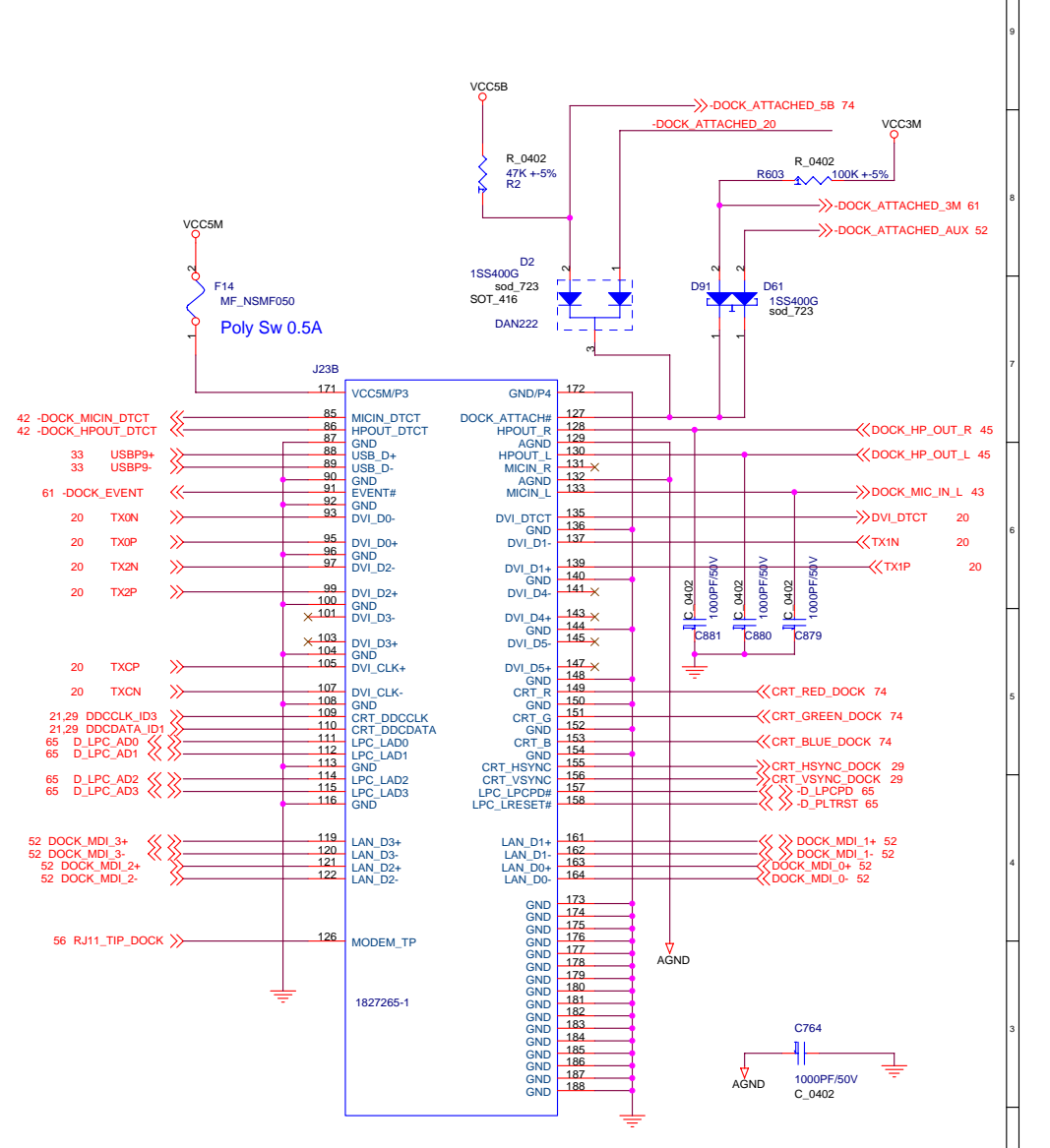
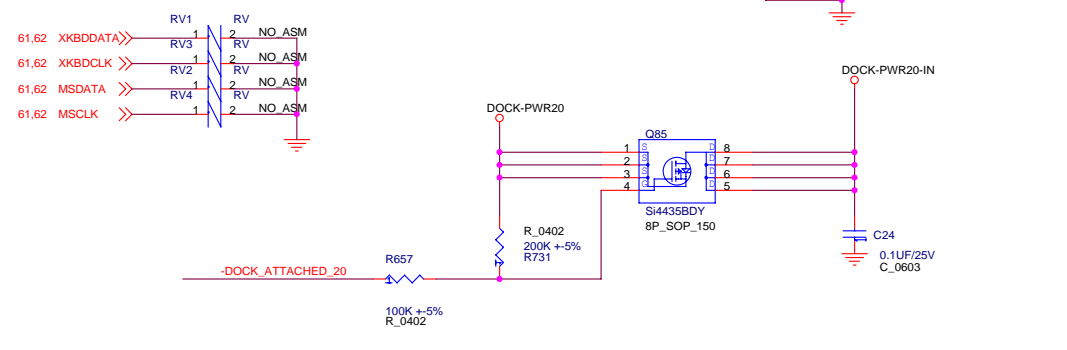
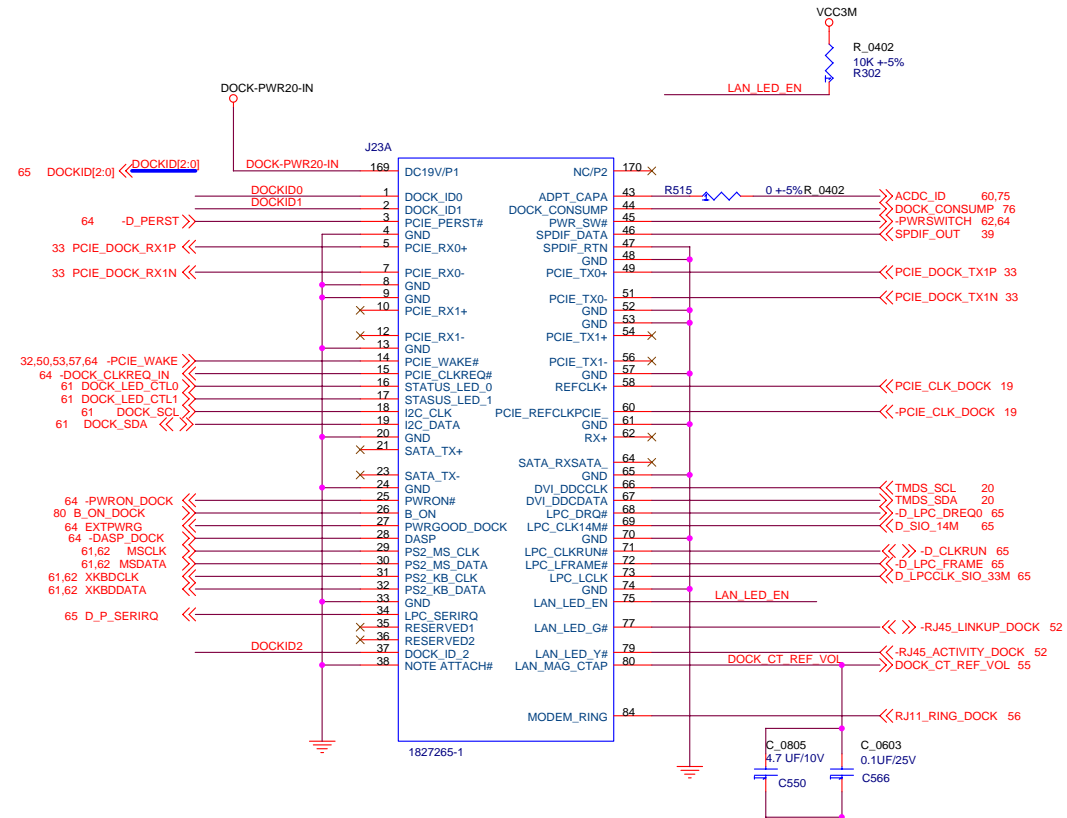

NO DOCKING SUPPORT:
No ASM in this page except R2 and R603.

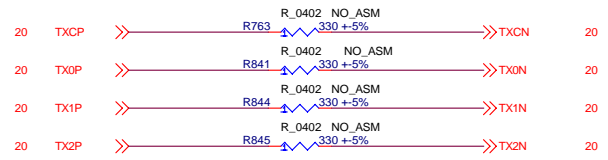

DESIGNER	J.CHEN	
CHECKED	Ogawa & OKU	
APPROVED	CHUJUO	Part No. XXXXXX
CLASS	CHUJUO	EC No. XXXXXX
<small>THIS DOCUMENT IS THE PROPERTY OF LENOVO. ITS USE IS AUTHORIZED ONLY FOR RESPONDING TO A REQUEST FOR QUOTATION OR FOR THE PERFORMANCE OF WORK FOR LENOVO. ALL QUESTIONS MUST BE REFERRED TO THE LENOVO PURCHASING DEPARTMENT.</small>		TITLE: Waikiki_1.1 Ver. 03.04
LENOVO CONFIDENTIAL		DOCK CONN
		sheet 59 of 100
		Wednesday, February 14, 2007

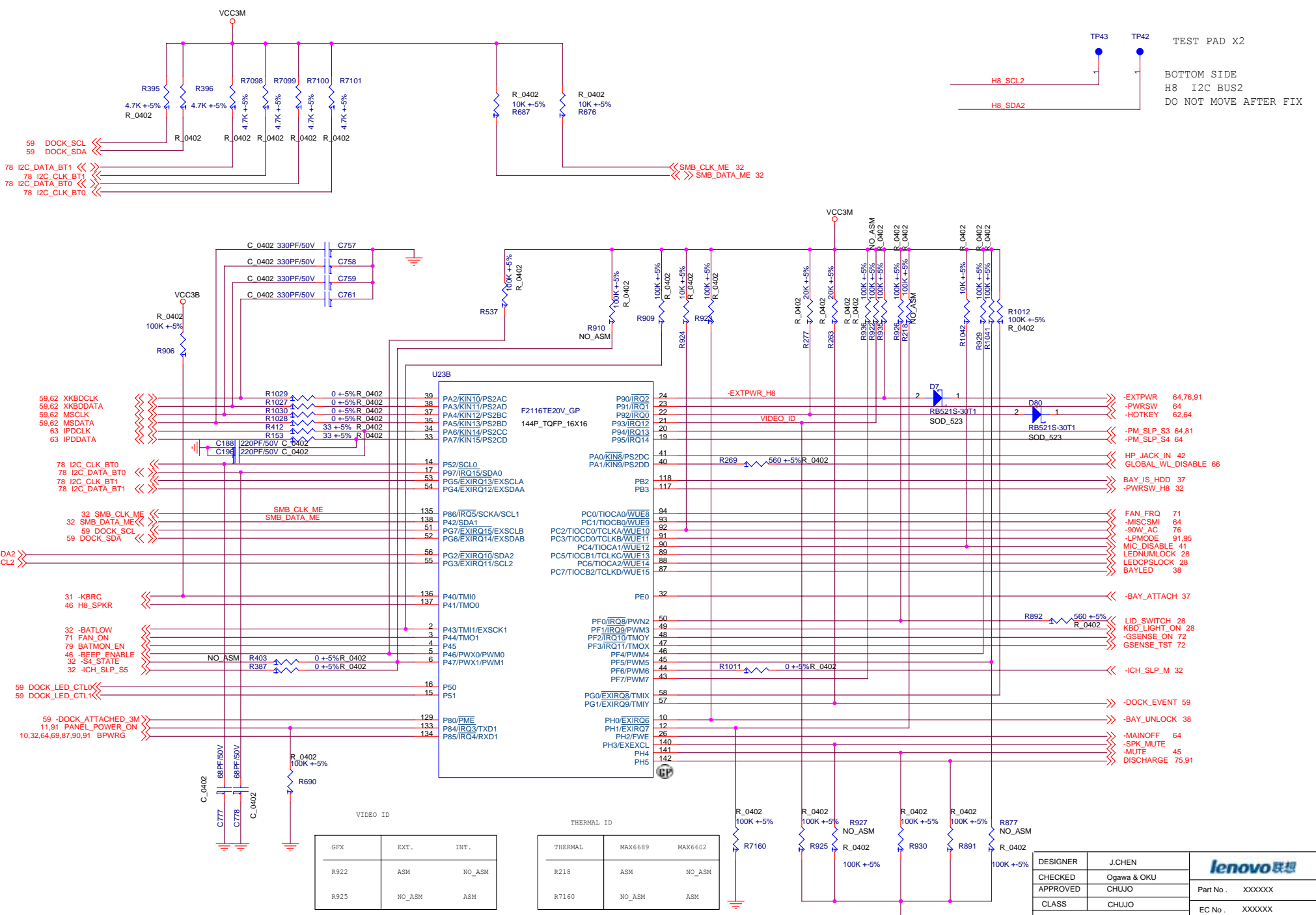

TEST PAD X2
 BOTTOM SIDE
 H8 I2C BUS2
 DO NOT MOVE AFTER FIX

VIDEO ID

GFX	EXT.	INT.
R922	ASM	NO_ASM
R925	NO_ASM	ASM

THERMAL ID

THERMAL	MAX6689	MAX6602
R218	ASM	NO_ASM
R7160	NO_ASM	ASM

DESIGNER	J.CHEN	
CHECKED	Ogawa & OKU	
APPROVED	CHUJO	Part No. XXXXXX
CLASS	CHUJO	EC No. XXXXXX
<small>THIS DOCUMENT IS THE PROPERTY OF LENOVO. ITS USE IS AUTHORIZED ONLY FOR RESPONDING TO A REQUEST FOR QUOTATION OR FOR THE PERFORMANCE OF WORK FOR LENOVO. ALL QUESTIONS MUST BE REFERRED TO THE LENOVO PURCHASING DEPARTMENT.</small>		
TITLE: Waikiki_1.1 Ver. V3.04		
H8S(2/2)		
sheet 61 of 100		
Wednesday, February 14, 2007		

LENOVO CONFIDENTIAL

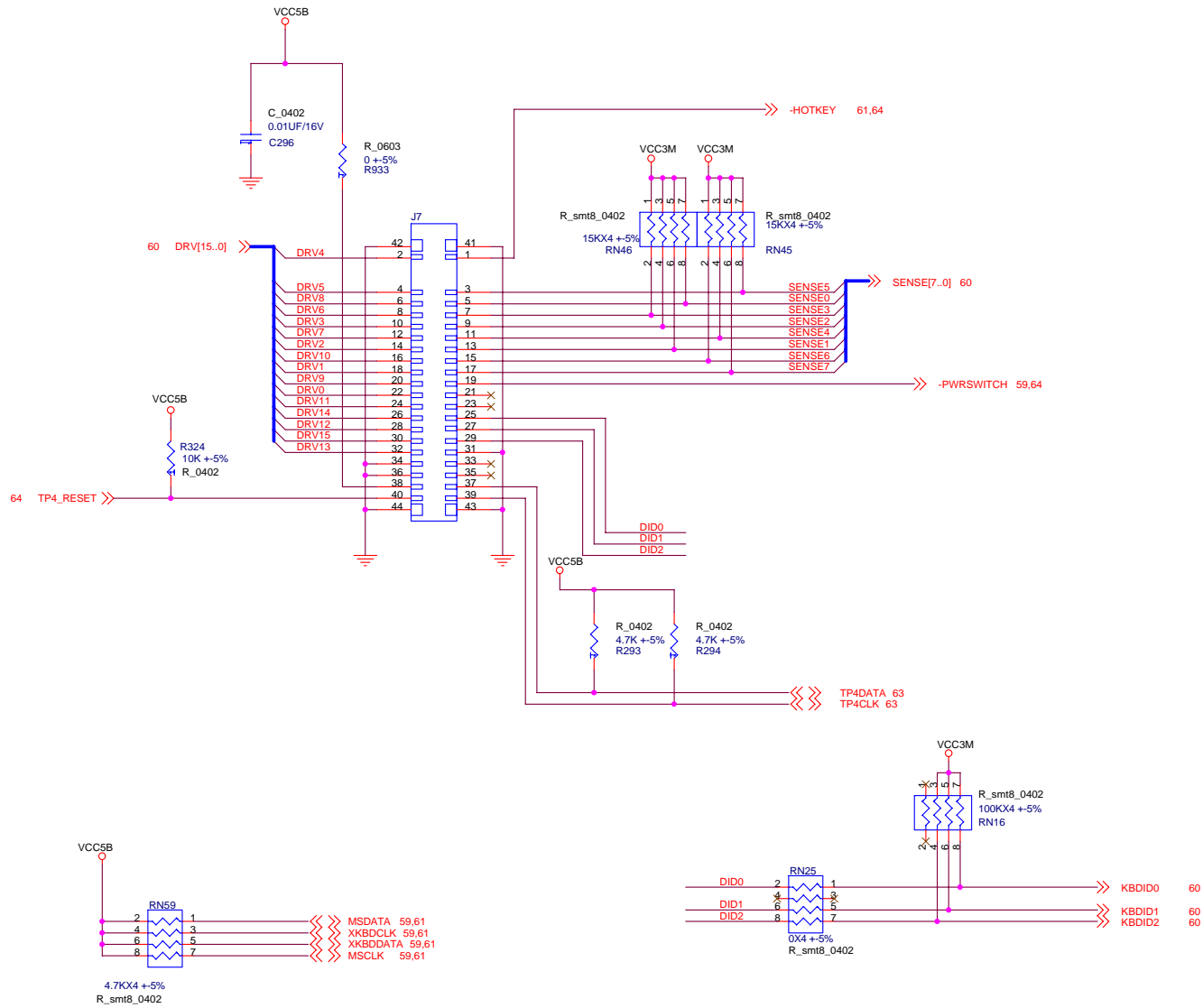

DESIGNER	J.CHEN	
CHECKED	Ogawa & OKU	
APPROVED	CHUJO	Part No . XXXXXX
CLASS	CHUJO	EC No . XXXXXX
<small>THIS DOCUMENT IS THE PROPERTY OF LENOVO. ITS USE IS AUTHORIZED ONLY FOR RESPONDING TO A REQUEST FOR QUOTATION OR FOR THE PERFORMANCE OF WORK FOR LENOVO. ALL QUESTIONS MUST BE REFERRED TO THE LENOVO PURCHASING DEPARTMENT.</small>		TITLE: Waikiki_1.1 Ver. V3.04
LENOVO CONFIDENTIAL		KB CONN sheet 62 of 100 Wednesday, February 14, 2007

TouchPad/FingerPrint Support		
	SUPPORT	NO SUPPORT
F15	ASM	NO-ASM
R15	ASM	NO-ASM
R18	ASM	NO-ASM
R24	ASM	NO-ASM
R25	ASM	NO-ASM
J8	ASM	NO-ASM
F6	ASM	NO-ASM
C208	ASM	NO-ASM
C643	NO-ASM	NO-ASM
C5	ASM	NO-ASM
C6	ASM	NO-ASM
U24	ASM	NO-ASM
R26	ASM	ASM
R32	ASM	ASM
R7085	NO-ASM	ASM
R7086	NO-ASM	ASM

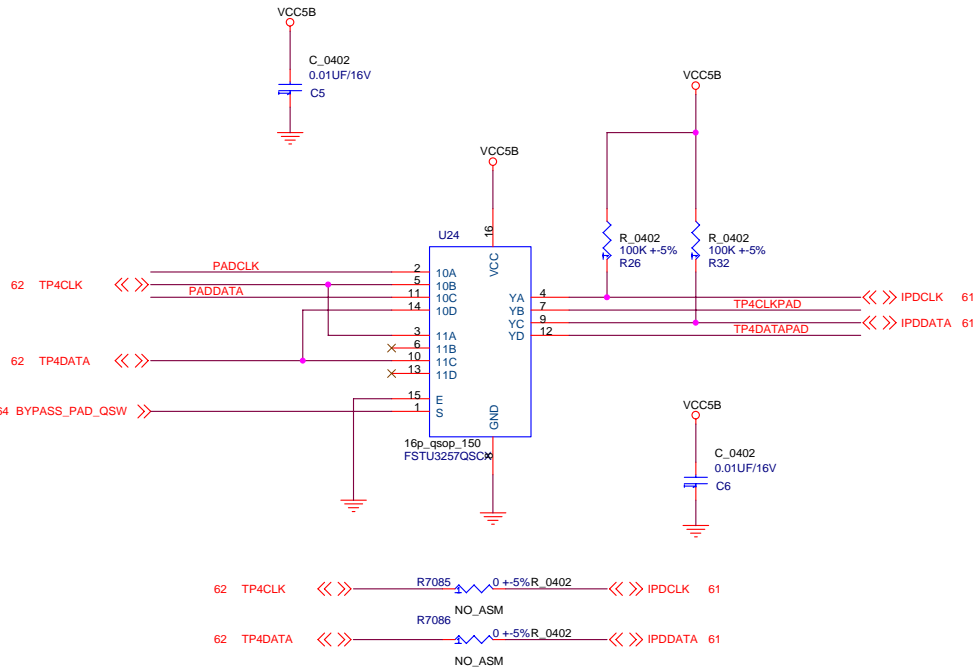
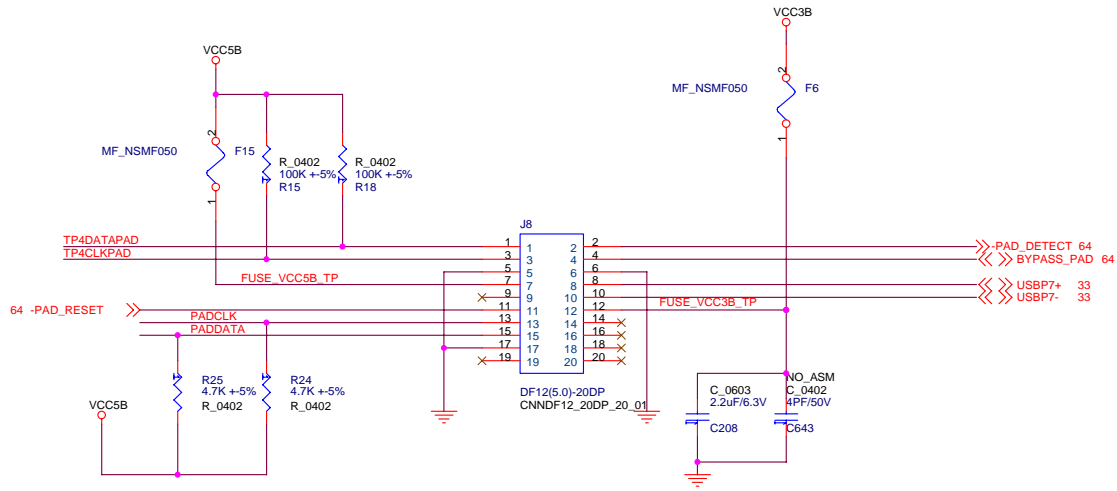

DESIGNER	J.CHEN	
CHECKED	Ogawa & OKU	
APPROVED	CHUJO	Part No . XXXXXX
CLASS	CHUJO	EC No . XXXXXX
THIS DOCUMENT IS THE PROPERTY OF LENOVO. ITS USE IS AUTHORIZED ONLY FOR RESPONDING TO A REQUEST FOR QUOTATION OR FOR THE PERFORMANCE OF WORK FOR LENOVO. ALL QUESTIONS MUST BE REFERRED TO THE LENOVO PURCHASING DEPARTMENT.		TITLE: Waikiki_1.1 Ver. V3.04
LENOVO CONFIDENTIAL		TP CONN
		sheet 63 of 100 Wednesday, February 14, 2007

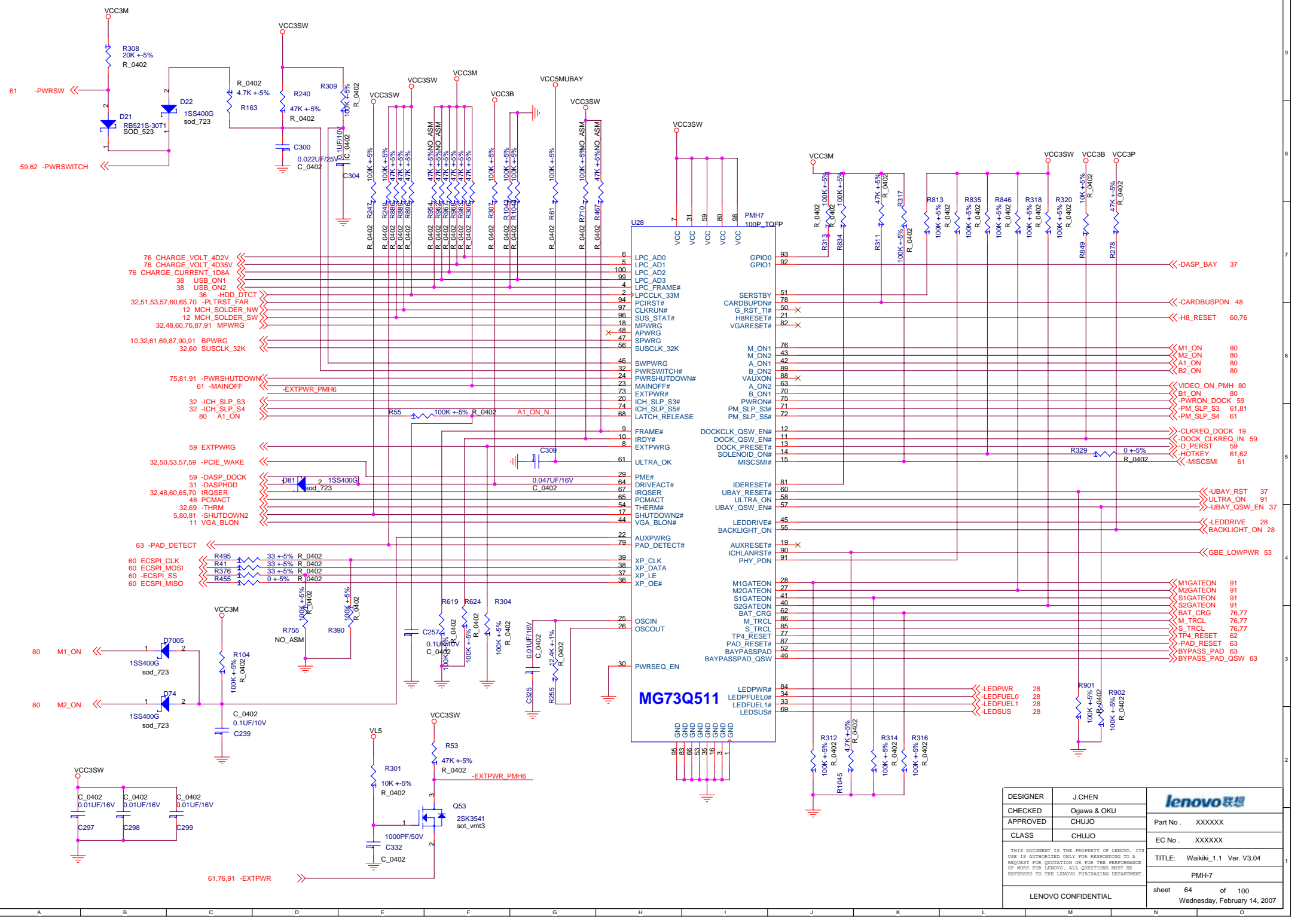

DESIGNER	J.CHEN	lenovo
CHECKED	Ogawa & OKU	
APPROVED	CHUJO	Part No. XXXXXX
CLASS	CHUJO	EC No. XXXXXX
<small>THIS DOCUMENT IS THE PROPERTY OF LENOVO. ITS USE IS AUTHORIZED ONLY FOR RESPONDING TO A REQUEST FOR QUOTATION OR FOR THE PERFORMANCE OF WORK FOR LENOVO. ALL QUESTIONS MUST BE REFERRED TO THE LENOVO PURCHASING DEPARTMENT.</small>		
TITLE: Waikiki_1.1 Ver. V3.04		
PMH-7		
sheet 64 of 100		
Wednesday, February 14, 2007		
LENOVO CONFIDENTIAL		

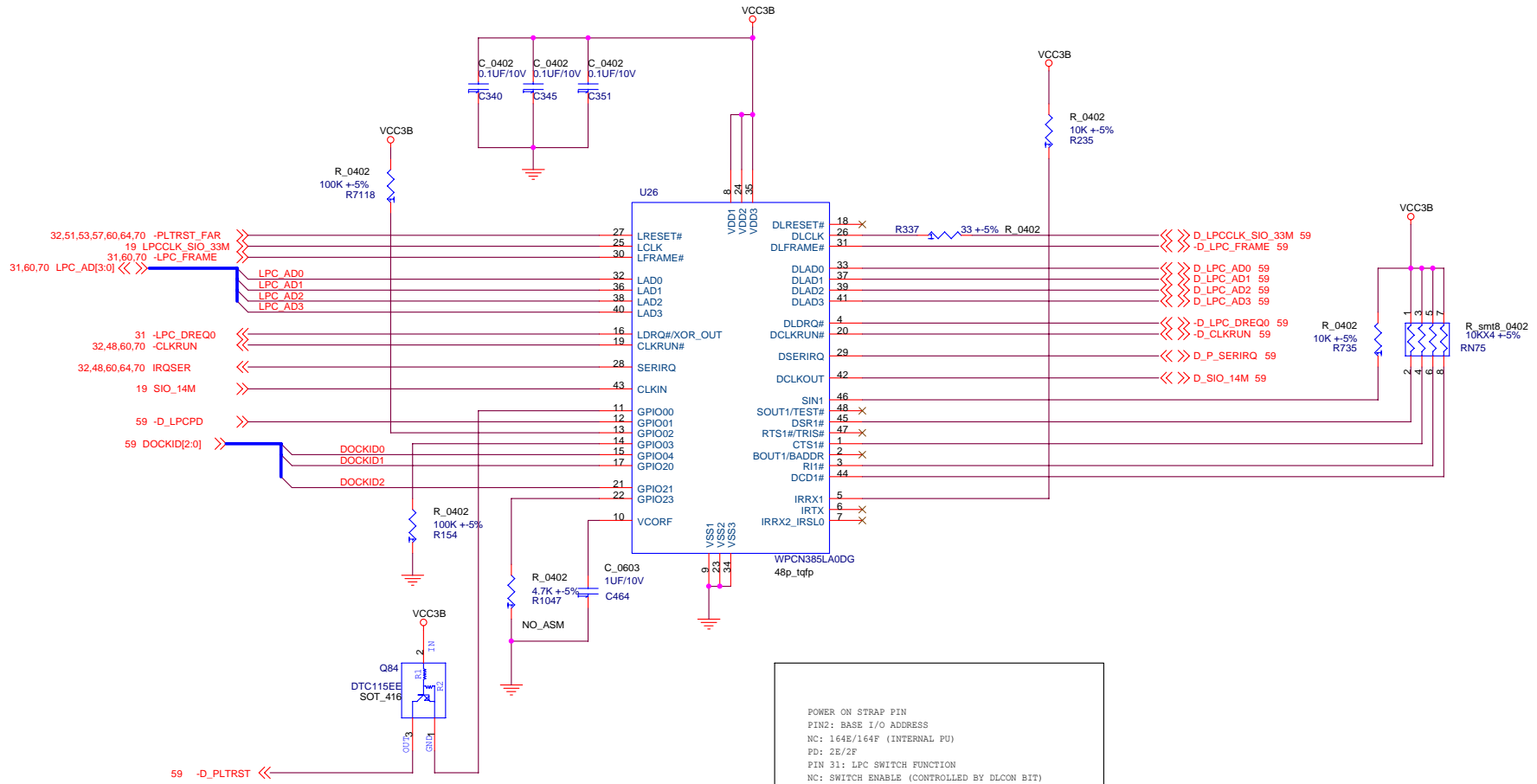



NO DOCKING SUPPORT:
All parts in this page are NO_ASM

GPIO23: RESERVED (INTERNAL PULLUP ENABLE)
GPIO03: LPC POWER DOWN FOR LEGACY IO BAY
GPIO02: LPC RESET# FOR LEGACY IO BAY
GPIO01: LPC POWER DOWN FOR DOCKING LPC DEVICE
GPIO00: LPC RESET# FOR DOCKING LPC DEVICE
GPIO ASSIGNMENT LIST
GPIO21: DOCK ID 2
GPIO20: DOCK ID 1
GPIO04: DOCK ID 0

POWER ON STRAP PIN
PIN2: BASE I/O ADDRESS
NC: 164E/164F (INTERNAL PU)
PD: 2E/2F
PIN 31: LPC SWITCH FUNCTION
NC: SWITCH ENABLE (CONTROLLED BY DLCON BIT)
PD: SWITCH DISABLE (FORCED TO BE DISCONNECTED)
PIN 47: TRISTATE
NC: NORMAL OPERATION
PD: ALL PINS FLOATING
PIN 48: TEST
NC: NORMAL OPERATION
PD: TEST MODE

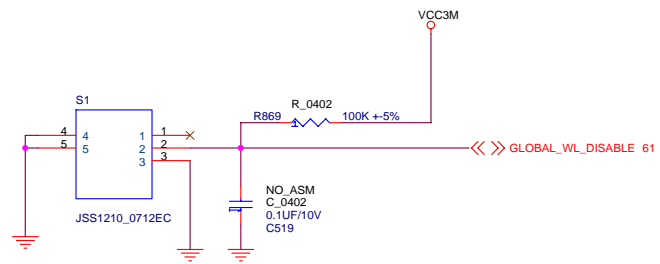
DESIGNER	J.CHEN	
CHECKED	Ogawa & OKU	
APPROVED	CHUJO	Part No. XXXXXX
CLASS	CHUJO	EC No. XXXXXX
THIS DOCUMENT IS THE PROPERTY OF LENOVO. ITS USE IS AUTHORIZED ONLY FOR RESPONDING TO A REQUEST FOR QUOTATION OR FOR THE PERFORMANCE OF WORK FOR LENOVO. ALL QUESTIONS MUST BE REFERRED TO THE LENOVO PURCHASING DEPARTMENT.		
		TITLE: Waikiki_1.1 Ver. V3.04
		SIO WPCN385SDG
LENOVO CONFIDENTIAL		sheet 65 of 100 Wednesday, February 14, 2007



DESIGNER	J.CHEN	
CHECKED	Ogawa & OKU	
APPROVED	CHUJO	Part No . XXXXXX
CLASS	CHUJO	EC No . XXXXXX
<small>THIS DOCUMENT IS THE PROPERTY OF LENOVO. ITS USE IS AUTHORIZED ONLY FOR RESPONDING TO A REQUEST FOR QUOTATION OR FOR THE PERFORMANCE OF WORK FOR LENOVO. ALL QUESTIONS MUST BE REFERRED TO THE LENOVO PURCHASING DEPARTMENT.</small>		TITLE: Waikiki_1.1 Ver. V3.04
LENOVO CONFIDENTIAL		WIRELESS DISABLE SW
		sheet 66 of 100 Wednesday, February 14, 2007

BLACK PAGE

DESIGNER	J.CHEN	
CHECKED	Ogawa & OKU	
APPROVED	CHUJO	Part No . XXXXXX
CLASS	CHUJO	EC No . XXXXXX
<small>THIS DOCUMENT IS THE PROPERTY OF LENOVO. ITS USE IS AUTHORIZED ONLY FOR RESPONDING TO A REQUEST FOR QUOTATION OR FOR THE PERFORMANCE OF WORK FOR LENOVO. ALL QUESTIONS MUST BE REFERRED TO THE LENOVO PURCHASING DEPARTMENT.</small>		TITLE: Waikiki_1.1 Ver. V3.04
LENOVO CONFIDENTIAL		SERIAL INTERFACE
		sheet 67 of 100 Wednesday, February 14, 2007

BLACK PAGE

DESIGNER	J.CHEN	
CHECKED	Ogawa & OKU	
APPROVED	CHUJO	Part No . XXXXXX
CLASS	CHUJO	EC No . XXXXXX
<small>THIS DOCUMENT IS THE PROPERTY OF LENOVO. ITS USE IS AUTHORIZED ONLY FOR RESPONDING TO A REQUEST FOR QUOTATION OR FOR THE PERFORMANCE OF WORK FOR LENOVO. ALL QUESTIONS MUST BE REFERRED TO THE LENOVO PURCHASING DEPARTMENT.</small>		TITLE: Waikiki_1.1 Ver. V3.04
LENOVO CONFIDENTIAL		BLANK PAGE
		sheet 68 of 100 Wednesday, February 14, 2007

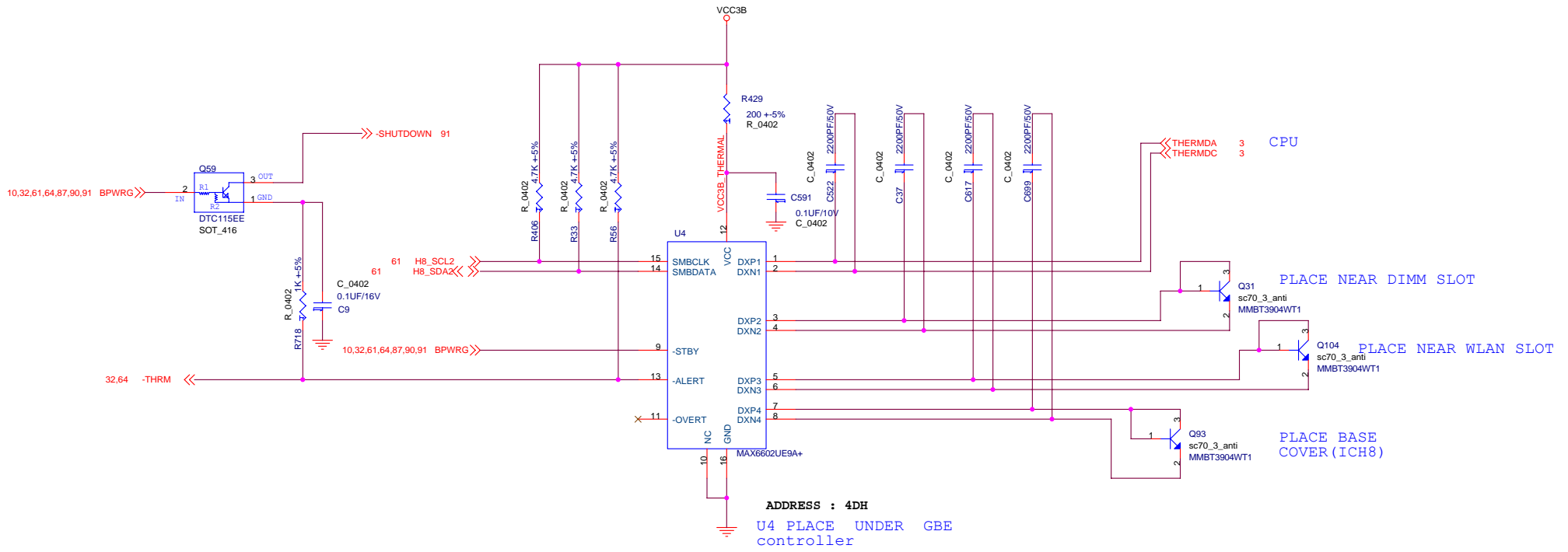

DESIGNER	J.CHEN	
CHECKED	Ogawa & OKU	
APPROVED	CHUJO	Part No. XXXXXX
CLASS	CHUJO	EC No. XXXXXX
<small>THIS DOCUMENT IS THE PROPERTY OF LENOVO. ITS USE IS AUTHORIZED ONLY FOR RESPONDING TO A REQUEST FOR QUOTATION OR FOR THE PERFORMANCE OF WORK FOR LENOVO. ALL QUESTIONS MUST BE REFERRED TO THE LENOVO PURCHASING DEPARTMENT.</small>		TITLE: Waikiki_1.1 Ver. V3.04
LENOVO CONFIDENTIAL		THERMAL SENSOR
		sheet 69 of 100
		Wednesday, February 14, 2007

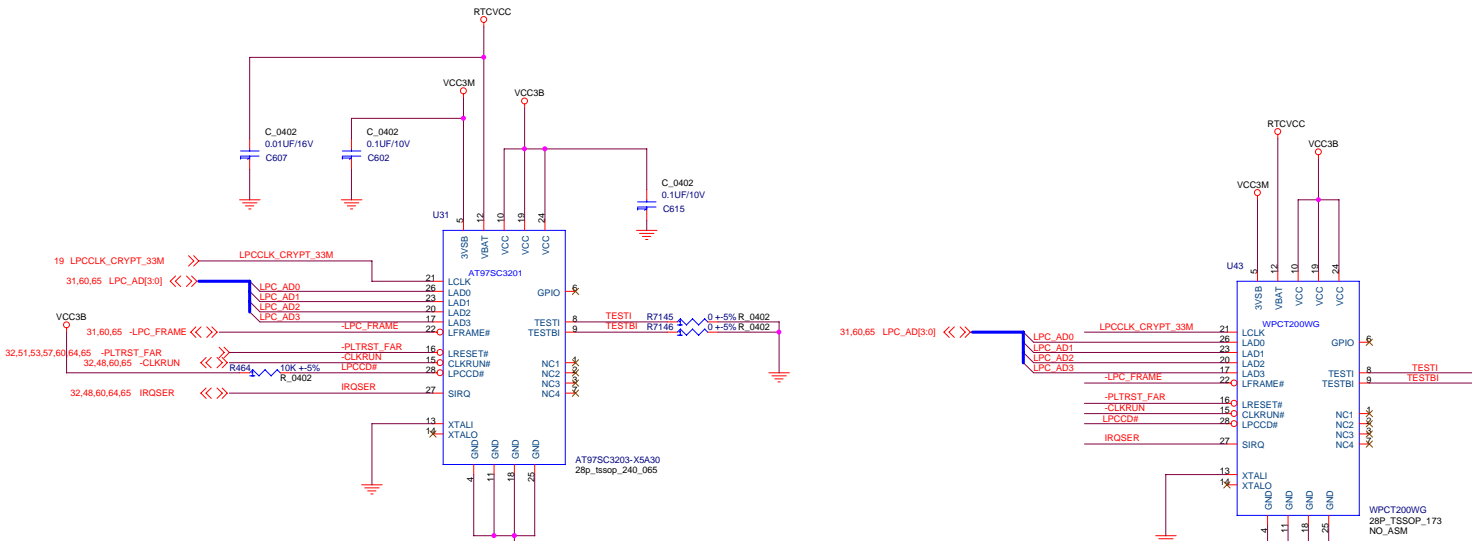

TPM FUNCTION	9.7X6.1MM	9.7X4.4MM
U31	ASM	NO_ASM
U43	NO_ASM	ASM

	TPM support	
	YES	NO
R297	ASM	NOASM (page19)
U31/U43	ASM	NOASM
C602	ASM	NOASM
C607	ASM	NOASM
C615	ASM	NOASM
R464	ASM	NOASM
R7145	ASM	NOASM
R7146	ASM	NOASM

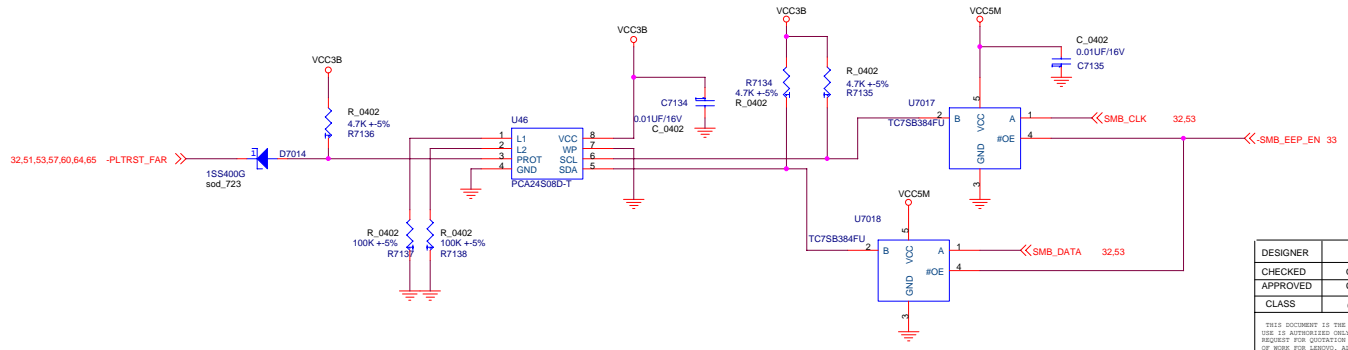
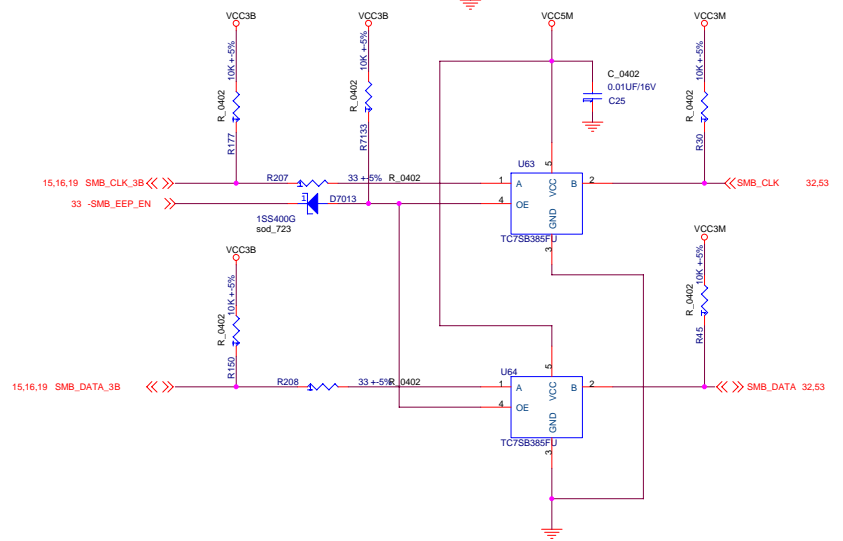

DESIGNER	J.CHEN	
CHECKED	Ogawa & OKU	
APPROVED	CHUJO	Part No. XXXXXX
CLASS	CHUJO	EC No. XXXXXX
TITLE: Waikiki_1.1 Ver. V3.04		I2C BUS/SMBUS
sheet 70 of 100 Wednesday, February 14, 2007		

THIS DOCUMENT IS THE PROPERTY OF LENOVO. ITS USE IS AUTHORIZED ONLY FOR RESPONDING TO A REQUEST FOR QUOTATION OR FOR THE PERFORMANCE OF WORK FOR LENOVO. ALL QUESTIONS MUST BE REFERRED TO THE LENOVO PURCHASING DEPARTMENT.

LENOVO CONFIDENTIAL

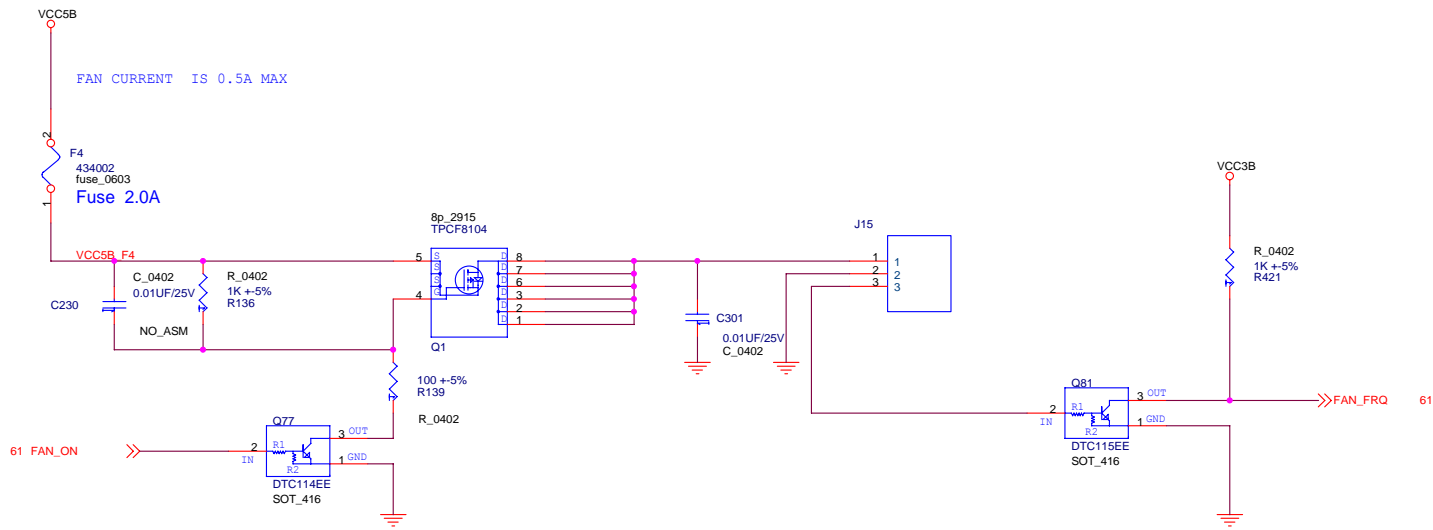

DESIGNER	J.CHEN	
CHECKED	Ogawa & OKU	
APPROVED	CHUJO	Part No . XXXXXX
CLASS	CHUJO	EC No . XXXXXX
THIS DOCUMENT IS THE PROPERTY OF LENOVO. ITS USE IS AUTHORIZED ONLY FOR RESPONDING TO A REQUEST FOR QUOTATION OR FOR THE PERFORMANCE OF WORK FOR LENOVO. ALL QUESTIONS MUST BE REFERRED TO THE LENOVO PURCHASING DEPARTMENT.		TITLE: Waikiki_1.1 Ver. V3.04
LENOVO CONFIDENTIAL		FAN CONN
		sheet 71 of 100 Wednesday, February 14, 2007

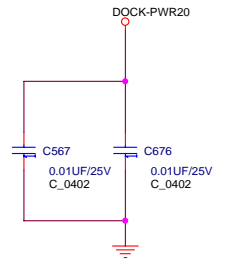
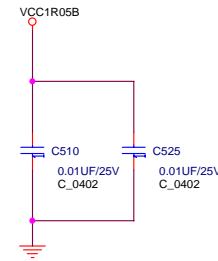
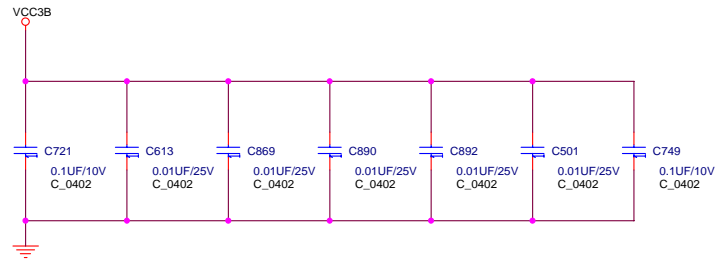
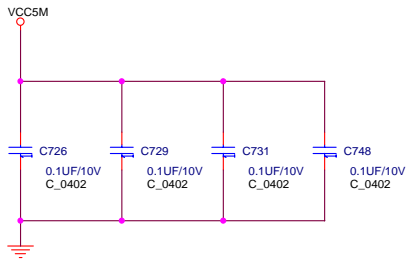
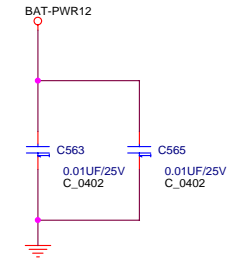
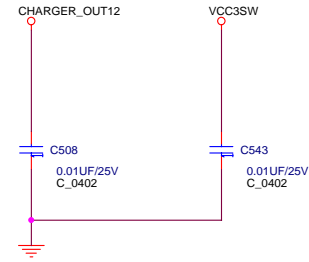
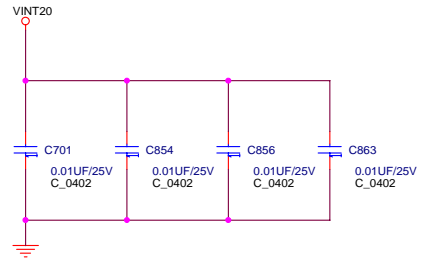
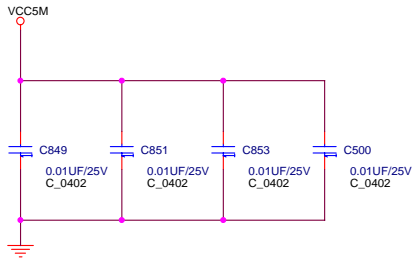
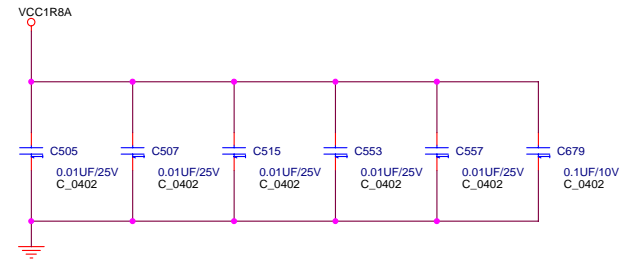
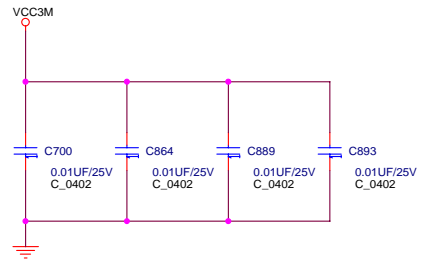
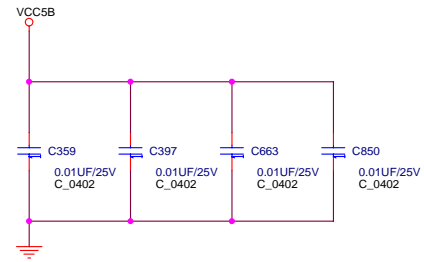

DESIGNER	J.CHEN	
CHECKED	Ogawa & OKU	
APPROVED	CHUJO	Part No. XXXXXX
CLASS	CHUJO	EC No. XXXXXX
<small>THIS DOCUMENT IS THE PROPERTY OF LENOVO. ITS USE IS AUTHORIZED ONLY FOR RESPONDING TO A REQUEST FOR QUOTATION OR FOR THE PERFORMANCE OF WORK FOR LENOVO. ALL QUESTIONS MUST BE REFERRED TO THE LENOVO PURCHASING DEPARTMENT.</small>		TITLE: Waikiki_1.1 Ver. V3.04
LENOVO CONFIDENTIAL		EMC DECOUPLING
		sheet 73 of 100 Wednesday, February 14, 2007

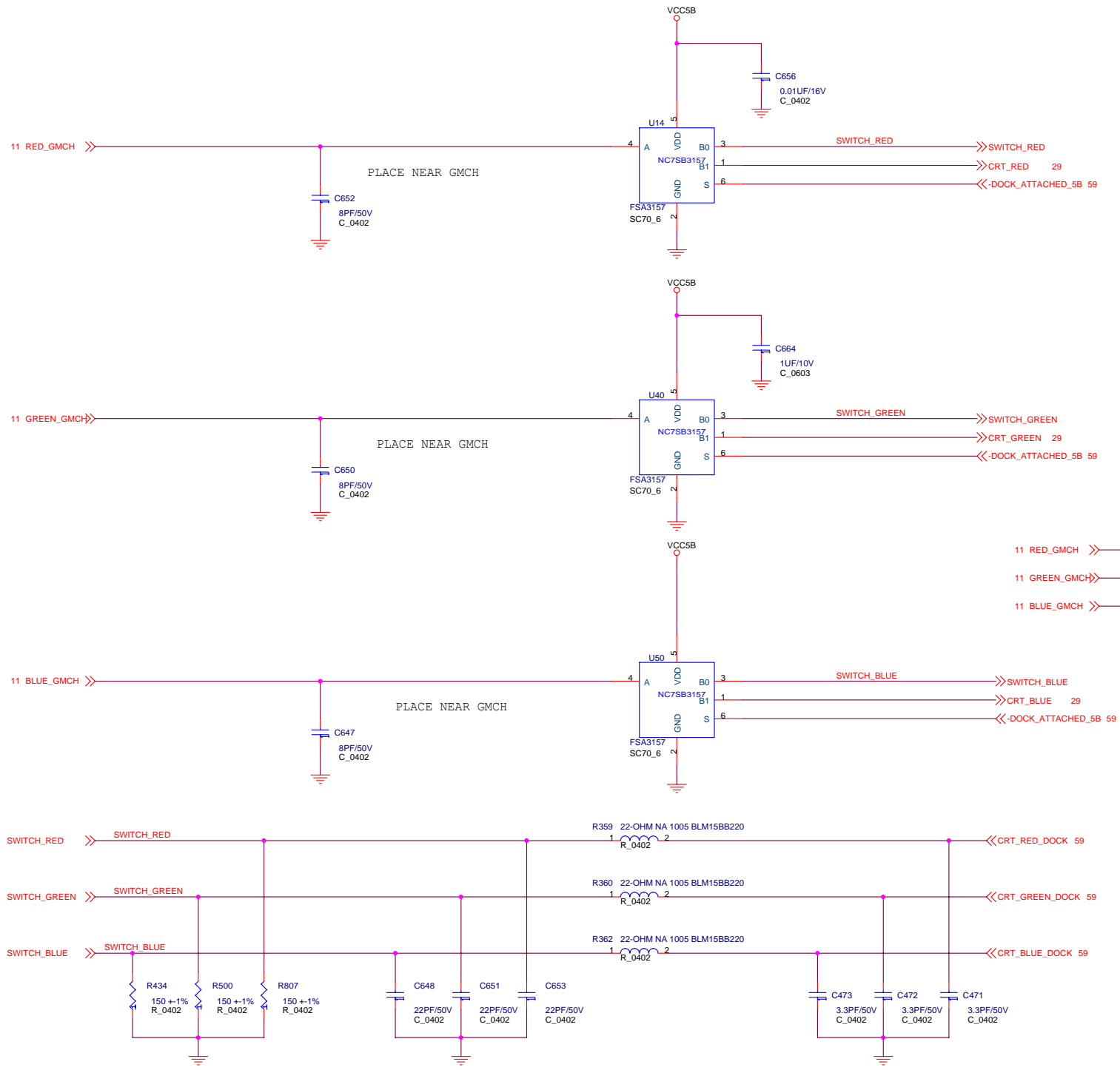

	DOCK	NO DOCK
C471	ASM	NO_ASM
C472	ASM	NO_ASM
C473	ASM	NO_ASM
C648	ASM	NO_ASM
C651	ASM	NO_ASM
C653	ASM	NO_ASM
C656	ASM	NO_ASM
C664	ASM	NO_ASM
R359	ASM	NO_ASM
R360	ASM	NO_ASM
R362	ASM	NO_ASM
R434	ASM	NO_ASM
R500	ASM	NO_ASM
R807	ASM	NO_ASM
U14	ASM	NO_ASM
U40	ASM	NO_ASM
U50	ASM	NO_ASM
R7087	NO_ASM	ASM
R7088	NO_ASM	ASM
R7089	NO_ASM	ASM

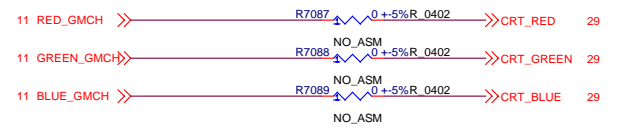

DESIGNER	J.CHEN	
CHECKED	Ogawa & OKU	
APPROVED	CHUJO	Part No. XXXXXX
CLASS	CHUJO	EC No. XXXXXX
<small>THIS DOCUMENT IS THE PROPERTY OF LENOVO. ITS USE IS AUTHORIZED ONLY FOR RESPONDING TO A REQUEST FOR QUOTATION OR FOR THE PERFORMANCE OF WORK FOR LENOVO. ALL QUESTIONS MUST BE REFERRED TO THE LENOVO PURCHASING DEPARTMENT.</small>		TITLE: Waikiki_1.1 Ver. V3.04
LENOVO CONFIDENTIAL		sheet 74 of 100 Wednesday, February 14, 2007

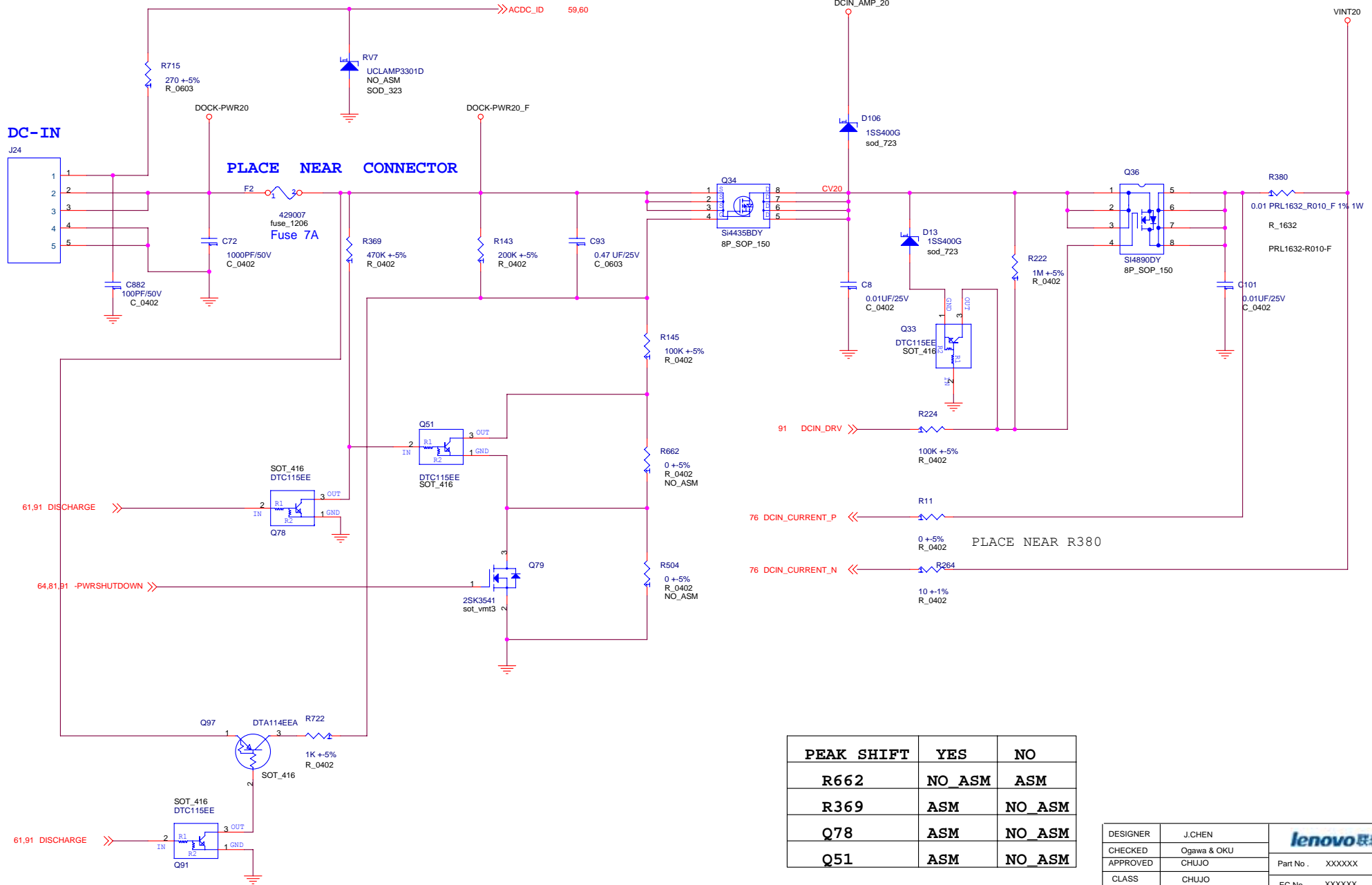

PEAK SHIFT	YES	NO
R662	NO_ASM	ASM
R369	ASM	NO_ASM
Q78	ASM	NO_ASM
Q51	ASM	NO_ASM

DESIGNER	J.CHEN	
CHECKED	Ogawa & OKU	
APPROVED	CHUJO	Part No. XXXXXX
CLASS	CHUJO	EC No. XXXXXX
THIS DOCUMENT IS THE PROPERTY OF LENOVO. ITS USE IS AUTHORIZED ONLY FOR RESPONDING TO A REQUEST FOR QUOTATION OR FOR THE PERFORMANCE OF WORK FOR LENOVO. ALL QUESTIONS MUST BE REFERRED TO THE LENOVO PURCHASING DEPARTMENT.		TITLE: Waikiwi_1.1 Ver. V3.04
LENOVO CONFIDENTIAL		DC-IN
		sheet 75 of 100
		Wednesday, February 14, 2007

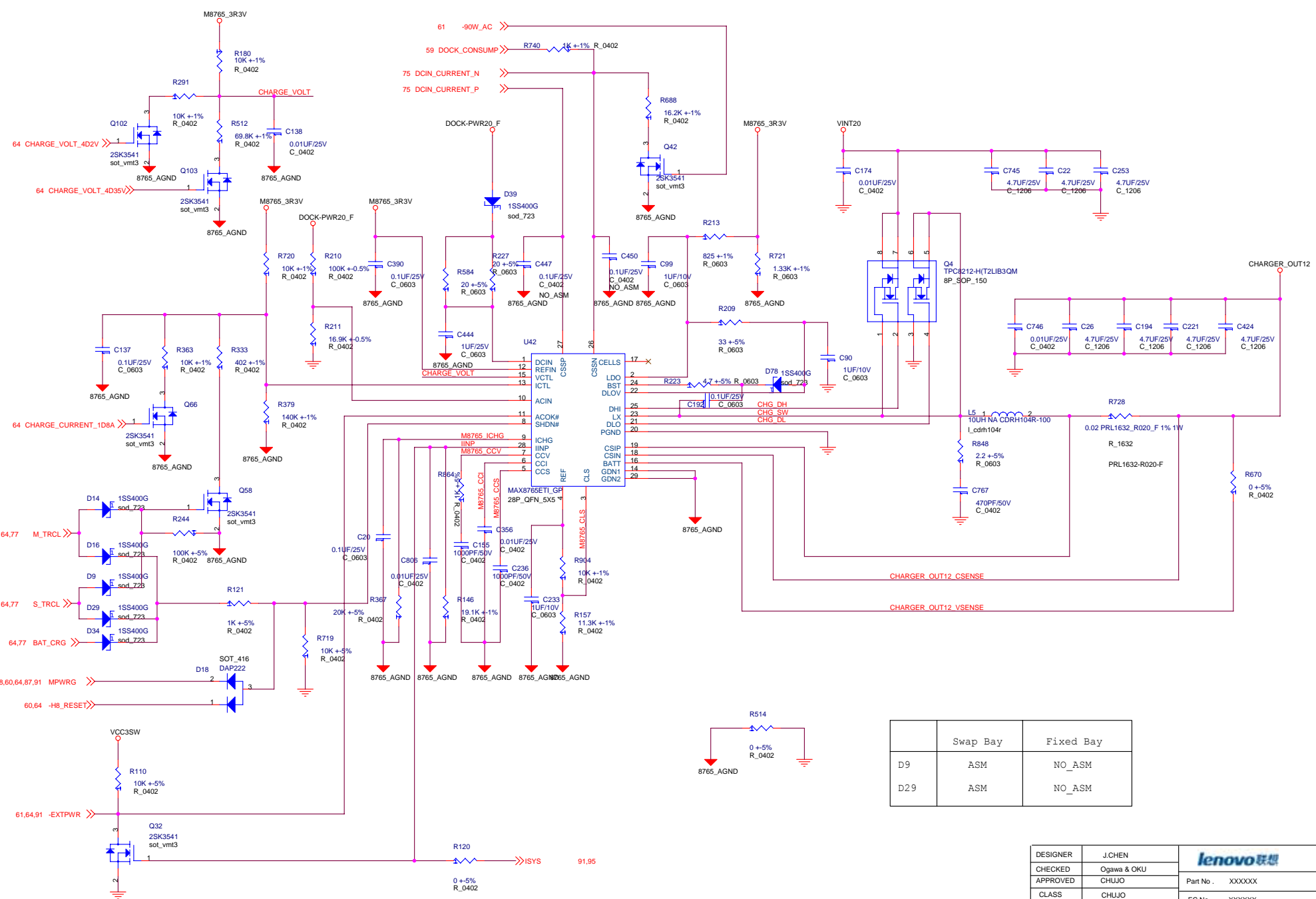

	Swap Bay	Fixed Bay
D9	ASM	NO_ASM
D29	ASM	NO_ASM

DESIGNER	J.CHEN	
CHECKED	Ogawa & OKU	
APPROVED	CHUJO	
CLASS	CHUJO	
<small>THIS DOCUMENT IS THE PROPERTY OF LENOVO. ITS USE IS AUTHORIZED ONLY FOR RESPONDING TO A REQUEST FOR QUOTATION OR FOR THE PERFORMANCE OF WORK FOR LENOVO. ALL OTHERS MUST BE REFERRED TO THE LENOVO PURCHASING DEPARTMENT.</small>		Part No. XXXXXX
		EC No. XXXXXX
		TITLE: Waikiki_1.1 Ver.V3.04
		BATTERY CHARGER(MAX8765)
LENOVO CONFIDENTIAL		sheet 76 of 100 Wednesday, February 14, 2007

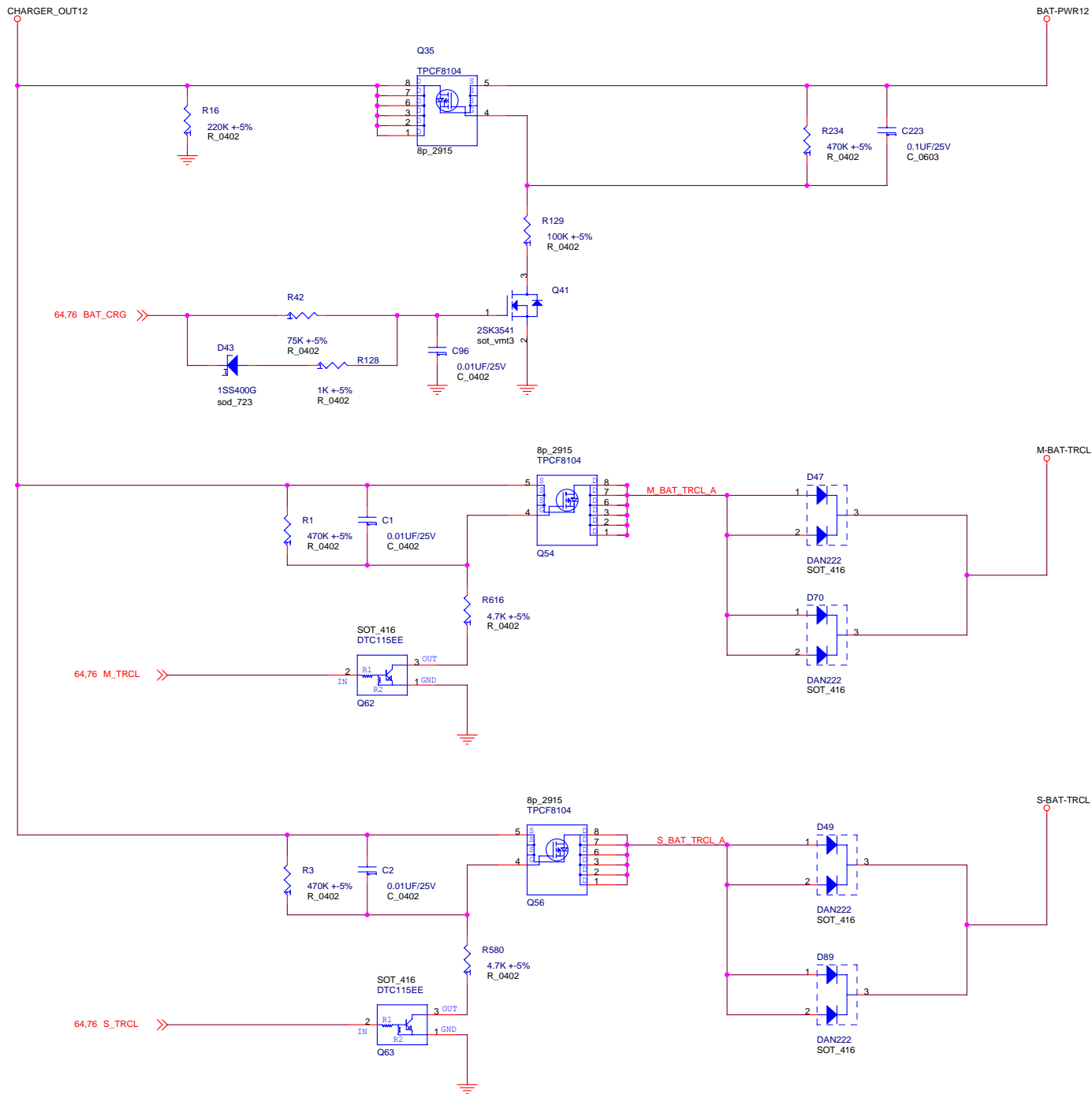

	Swap Bay	Fixed Bay
R3	ASM	NO-ASM
C2	ASM	NO-ASM
Q56	ASM	NO-ASM
Q63	ASM	NO-ASM
R580	ASM	NO-ASM
D49	ASM	NO-ASM
D89	ASM	NO-ASM

DESIGNER	J.CHEN	
CHECKED	Ogawa & OKU	
APPROVED	CHUJO	Part No. XXXXXX
CLASS	CHUJO	EC No. XXXXXX
<small>THIS DOCUMENT IS THE PROPERTY OF LENOVO. ITS USE IS AUTHORIZED ONLY FOR RESPONDING TO A REQUEST FOR QUOTATION OR FOR THE PERFORMANCE OF WORK FOR LENOVO. ALL QUESTIONS MUST BE REFERRED TO THE LENOVO PURCHASING DEPARTMENT.</small>		
TITLE: Waikiki_1.1 Ver. V3.04		
CHARGE SELECTOR		
LENOVO CONFIDENTIAL		
sheet 77 of 100 Wednesday, February 14, 2007		

MAIN BAT CONN

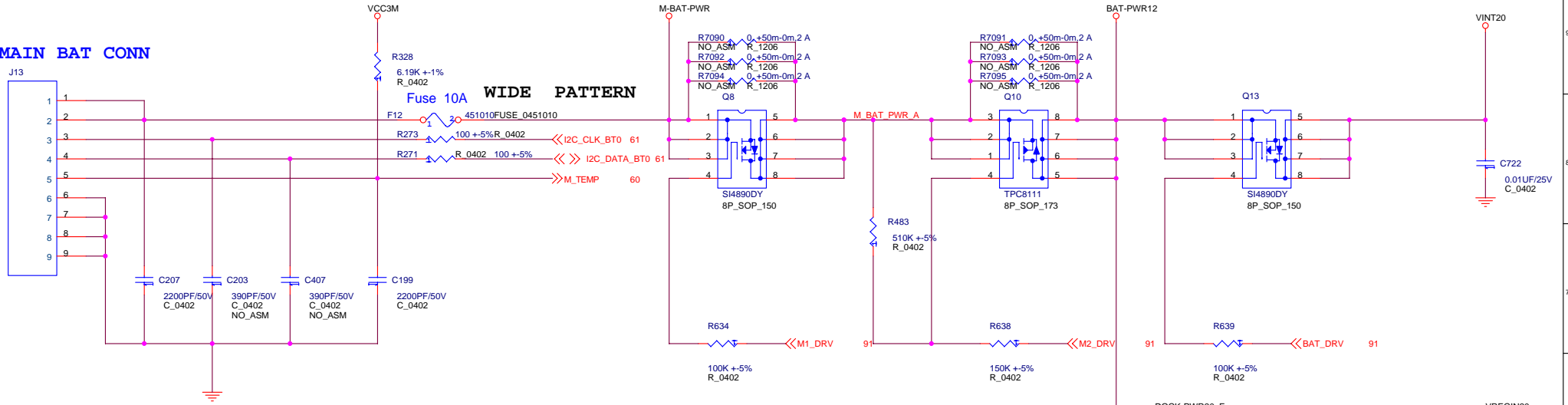

SECOND BAT CONN

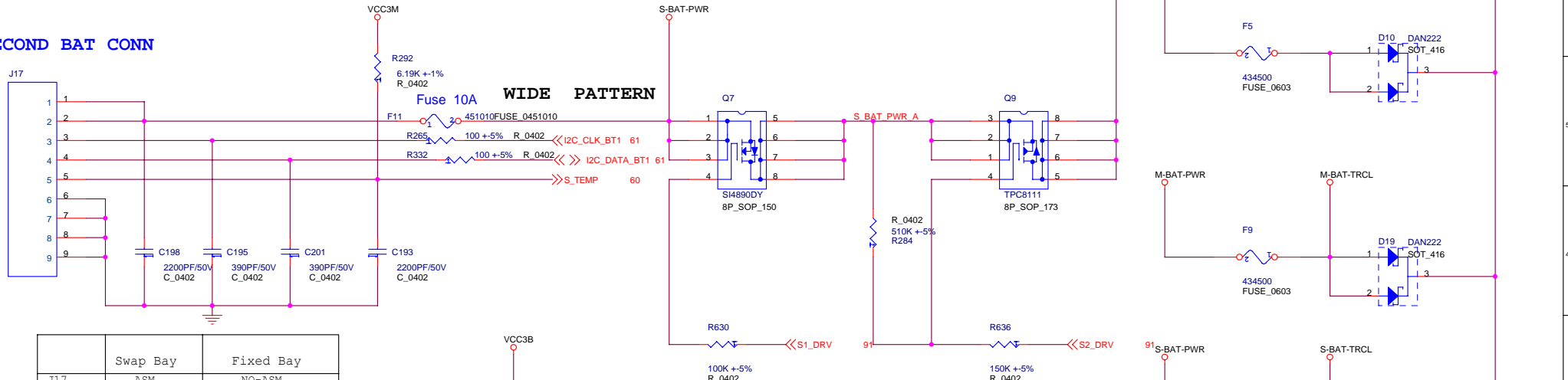

	Swap Bay	Fixed Bay
J17	ASM	NO-ASM
F11	ASM	NO-ASM
R265	ASM	NO-ASM
R332	ASM	NO-ASM
C198	ASM	NO-ASM
C195	ASM	NO-ASM
C201	ASM	NO-ASM
Q7	ASM	NO-ASM
Q9	ASM	NO-ASM
Q8	ASM	NO-ASM
Q10	ASM	NO-ASM
R630	ASM	NO-ASM
R284	ASM	NO-ASM
R636	ASM	NO-ASM
R7090	NO-ASM	ASM
R7091	NO-ASM	ASM
R7092	NO-ASM	ASM
R7093	NO-ASM	ASM
R7094	NO-ASM	ASM
R7095	NO-ASM	ASM
F10	ASM	NO-ASM
D23	ASM	NO-ASM

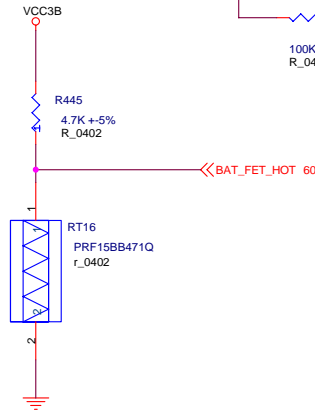

DESIGNER	J.CHEN	
CHECKED	Ogawa & OKU	
APPROVED	CHUJUO	Part No. XXXXXX
CLASS	CHUJUO	EC No. XXXXXX
<small>THIS DOCUMENT IS THE PROPERTY OF LENOVO. ITS USE IS AUTHORIZED ONLY FOR RESPONDING TO A REQUEST FOR QUOTATION OR FOR THE PERFORMANCE OF WORK FOR LENOVO. ALL QUESTIONS MUST BE REFERRED TO THE LENOVO PURCHASING DEPARTMENT.</small>		TITLE: Waikiki_1.1 Ver. V3.04
LENOVO CONFIDENTIAL		BATTERY INPUT
		sheet 78 of 100
		Wednesday, February 14, 2007

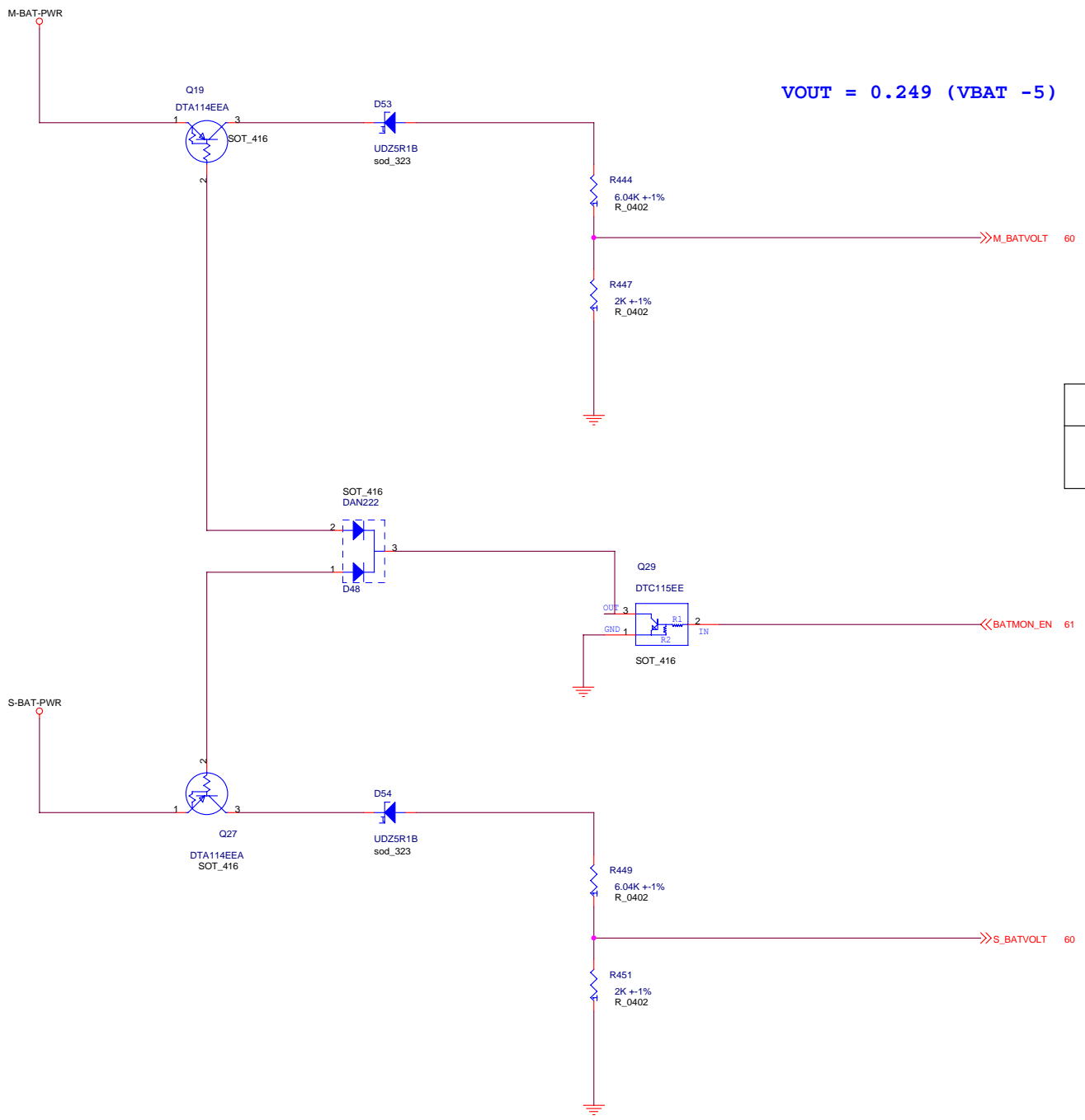

VOUT = 0.249 (VBAT - 5)

	Swap Bay	Fixed Bay
Q27	ASM	NO-ASM
D54	ASM	NO-ASM
R449	ASM	NO-ASM

DESIGNER	J.CHEN	
CHECKED	Ogawa & OKU	
APPROVED	CHUJO	Part No. XXXXXX
CLASS	CHUJO	EC No. XXXXXX
<small>THIS DOCUMENT IS THE PROPERTY OF LENOVO. ITS USE IS AUTHORIZED ONLY FOR RESPONDING TO A REQUEST FOR QUOTATION OR FOR THE PERFORMANCE OF WORK FOR LENOVO. ALL QUESTIONS MUST BE REFERRED TO THE LENOVO PURCHASING DEPARTMENT.</small>		TITLE: Waikiki_1.1 Ver. V3.04
LENOVO CONFIDENTIAL		BATTERY MONITOR
		sheet 79 of 100 Wednesday, February 14, 2007

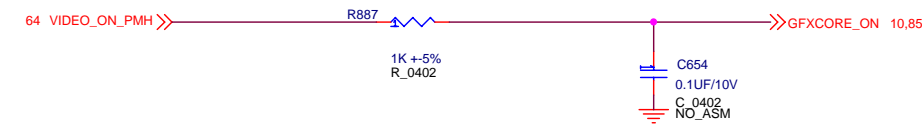
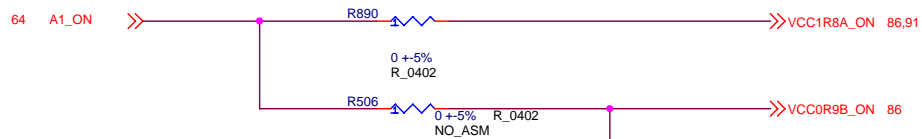
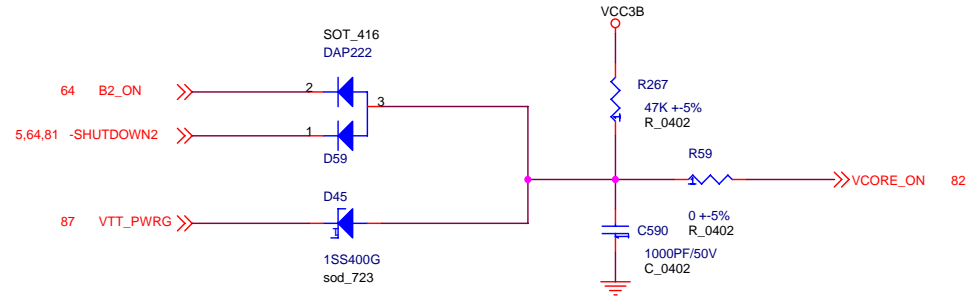
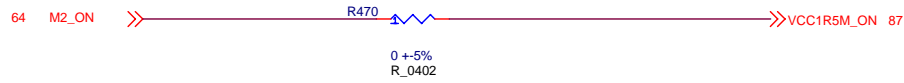
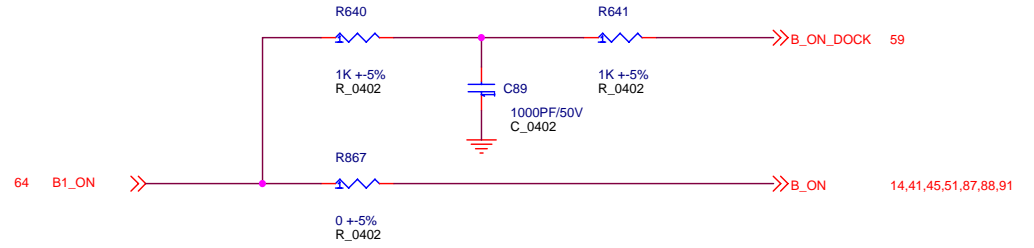
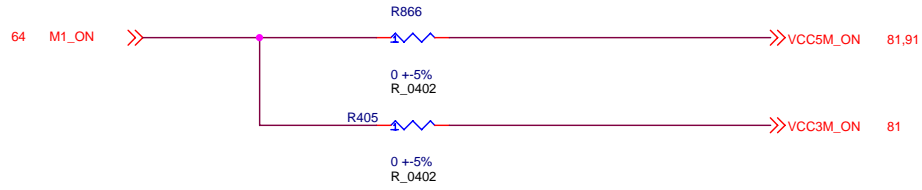

DESIGNER	J.CHEN	
CHECKED	Ogawa & OKU	
APPROVED	CHUJO	Part No . XXXXXX
CLASS	CHUJO	EC No . XXXXXX
THIS DOCUMENT IS THE PROPERTY OF LENOVO. ITS USE IS AUTHORIZED ONLY FOR RESPONDING TO A REQUEST FOR QUOTATION OR FOR THE PERFORMANCE OF WORK FOR LENOVO. ALL QUESTIONS MUST BE REFERRED TO THE LENOVO PURCHASING DEPARTMENT.		TITLE: Waikiki_1.1 Ver. V3.04
LENOVO CONFIDENTIAL		POWER SEQUENCE
		sheet 80 of 100 Wednesday, February 14, 2007

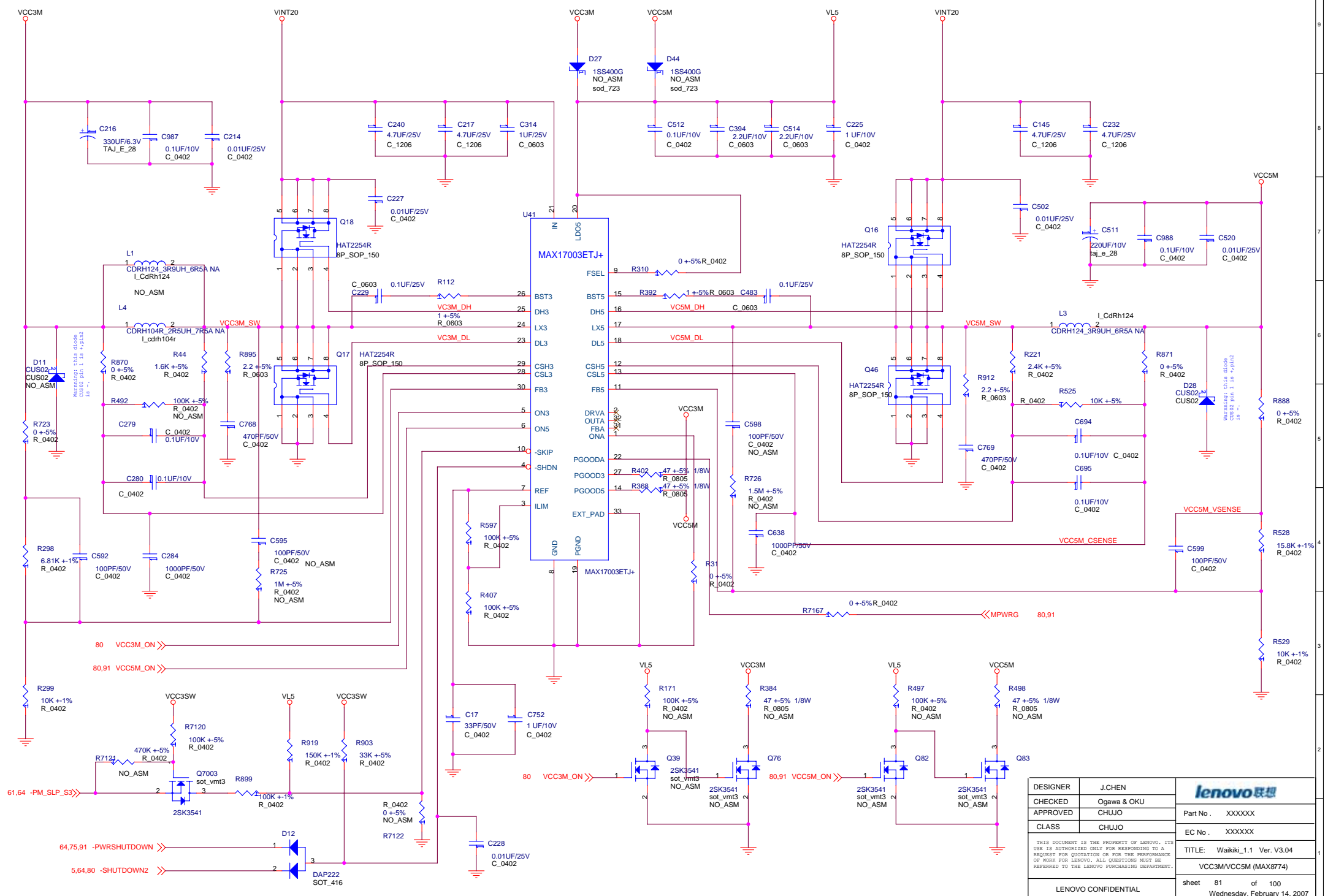

DESIGNER	J.CHEN	
CHECKED	Ogawa & OKU	
APPROVED	CHUJO	Part No. XXXXXX
CLASS	CHUJO	EC No. XXXXXX
<small>THIS DOCUMENT IS THE PROPERTY OF LENOVO. ITS USE IS AUTHORIZED ONLY FOR RESPONDING TO A REQUEST FOR QUOTATION OR FOR THE PERFORMANCE OF WORK FOR LENOVO. ALL QUESTIONS MUST BE REFERRED TO THE LENOVO PURCHASING DEPARTMENT.</small>		TITLE: Waikiki_1.1 Ver. V3.04
		VCC3M/VCC5M (MAX8774)
LENOVO CONFIDENTIAL		sheet 81 of 100 Wednesday, February 14, 2007

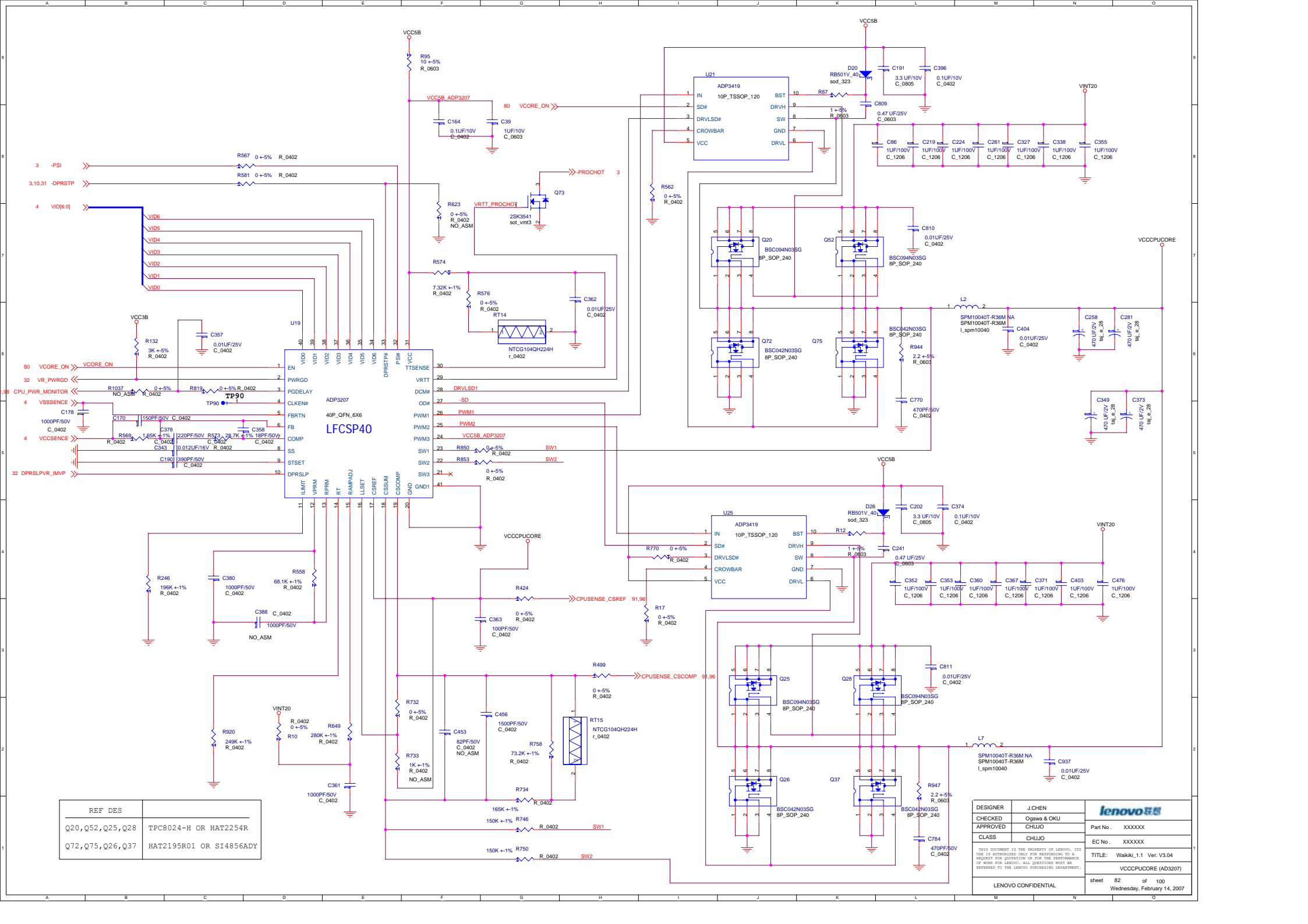

LFCSP40

REF DES	
Q20, Q52, Q25, Q28	TPC8024-H OR HAT2254R
Q72, Q75, Q26, Q37	HAT2195R01 OR SI4856ADY

DESIGNER	J.CHEN	
CHECKED	Ogawa & OKU	
APPROVED	CHUJO	Part No. XXXXXX
CLASS	CHUJO	EC No. XXXXXX
<small>THIS DOCUMENT IS THE PROPERTY OF Lenovo. ITS USE IS AUTHORIZED ONLY FOR RESPONDING TO A REQUEST FOR QUOTATION OR FOR THE PERFORMANCE OF WORK FOR Lenovo. ALL QUESTIONS MUST BE REFERRED TO THE Lenovo FORWARDING DEPARTMENT.</small>		TITLE: Waikiki_1.1 Ver. V3.04
		VCC5B_PUCORE (AD3207)
LENOVO CONFIDENTIAL		sheet 82 of 100 Wednesday, February 14, 2007

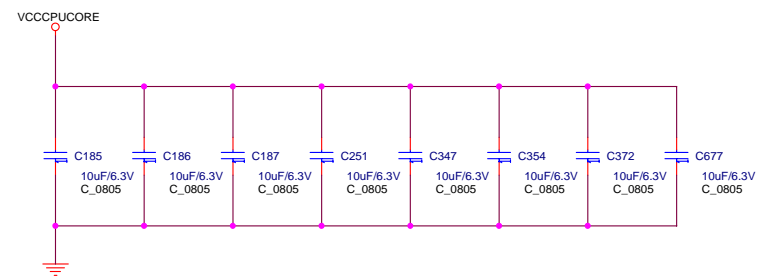
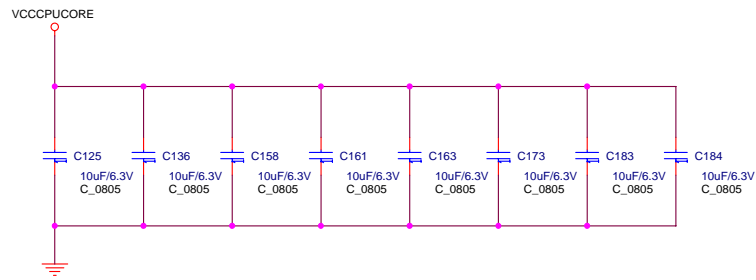

10UF 6.3V X5R 0805 1/16W X 16PCS

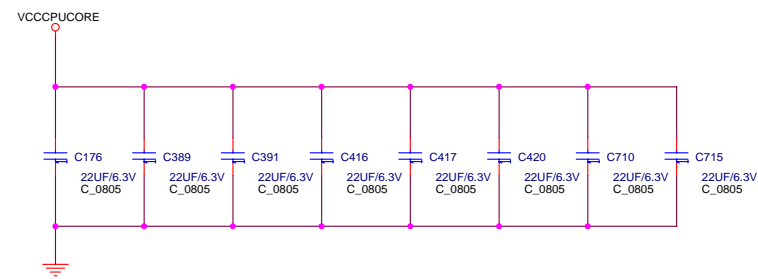
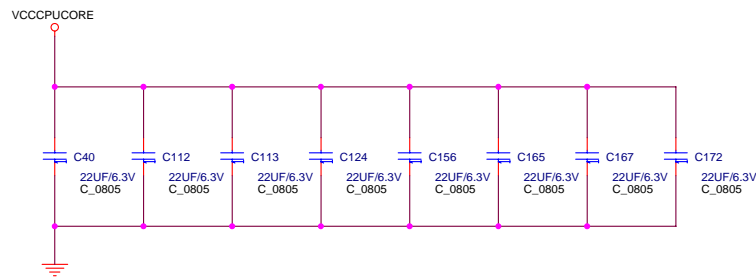

22UF 6.3V X5R 0805 1/16W X 16PCS

DESIGNER	J.CHEN	
CHECKED	Ogawa & OKU	
APPROVED	CHUJO	Part No . XXXXXX
CLASS	CHUJO	EC No . XXXXXX
THIS DOCUMENT IS THE PROPERTY OF LENOVO. ITS USE IS AUTHORIZED ONLY FOR RESPONDING TO A REQUEST FOR QUOTATION OR FOR THE PERFORMANCE OF WORK FOR LENOVO. ALL QUESTIONS MUST BE REFERRED TO THE LENOVO PURCHASING DEPARTMENT.		TITLE: Waikiki_1.1 Ver. V3.04
LENOVO CONFIDENTIAL		VCCCPUCORE DECOUPLING
		sheet 83 of 100 Wednesday, February 14, 2007

BLACK PAGE

DESIGNER	J.CHEN	
CHECKED	Ogawa & OKU	
APPROVED	CHUJO	Part No . XXXXXX
CLASS	CHUJO	EC No . XXXXXX
<small>THIS DOCUMENT IS THE PROPERTY OF LENOVO. ITS USE IS AUTHORIZED ONLY FOR RESPONDING TO A REQUEST FOR QUOTATION OR FOR THE PERFORMANCE OF WORK FOR LENOVO. ALL QUESTIONS MUST BE REFERRED TO THE LENOVO PURCHASING DEPARTMENT.</small>		TITLE: Waikiki_1.1 Ver. V3.04
LENOVO CONFIDENTIAL		VCC1R5M
		sheet 84 of 100 Wednesday, February 14, 2007

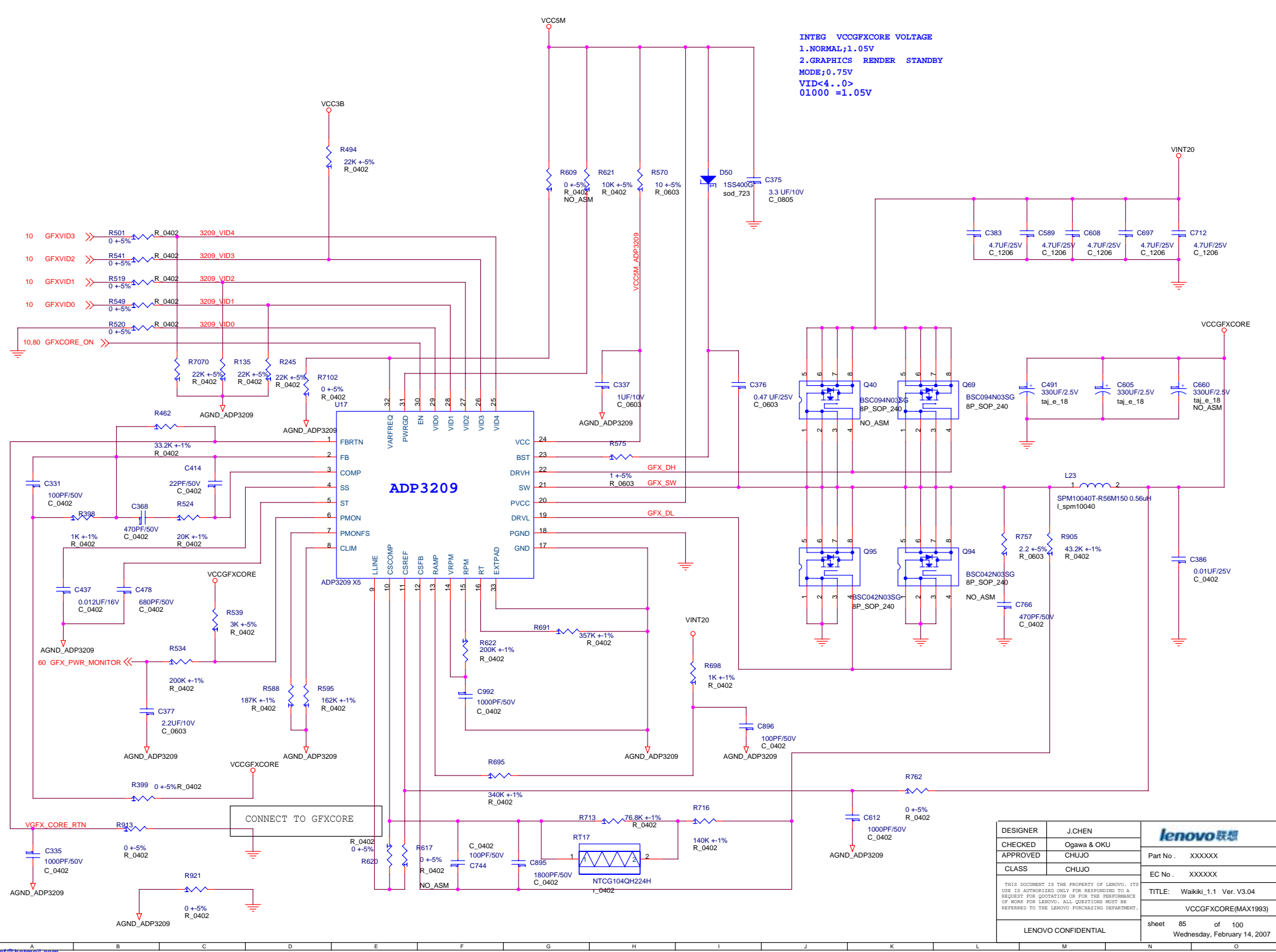

INTEG VCCGFXCORE VOLTAGE
 1.NORMAL;1.05V
 2.GRAPHICS RENDER STANDBY
 MODE;0.75V
 VID<4..0>
 01000 =1.05V

ADP3209

DESIGNER	J.CHEN	
CHECKED	Ogawa & OKU	
APPROVED	CHUJO	Part No. XXXXXX
CLASS	CHUJO	EC No. XXXXXX
<small>THIS DOCUMENT IS THE PROPERTY OF LENOVO. ITS USE IS AUTHORIZED ONLY FOR RESPONDING TO A REQUEST FOR QUOTATION OR FOR THE PERFORMANCE OF WORK FOR LENOVO. ALL QUESTIONS MUST BE REFERRED TO THE LENOVO PURCHASING DEPARTMENT.</small>		TITLE: Waikiki_1.1 Ver.V3.04
		VCCGFXCORE(MAX1993)
LENOVO CONFIDENTIAL		sheet 85 of 100 Wednesday, February 14, 2007

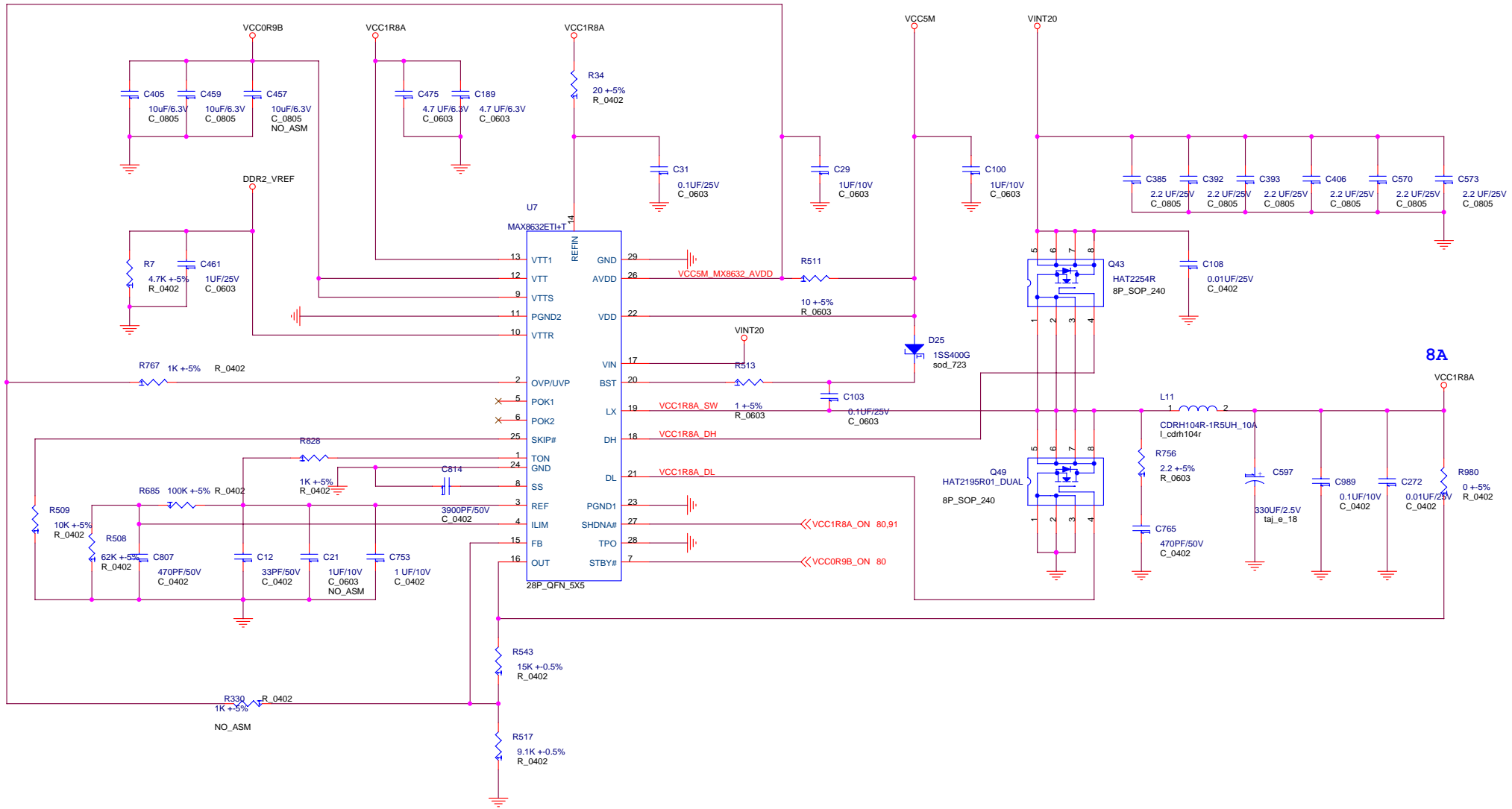

DESIGNER	J.CHEN	
CHECKED	Ogawa & OKU	
APPROVED	CHUJO	Part No. XXXXXX
CLASS	CHUJO	EC No. XXXXXX
<small>THIS DOCUMENT IS THE PROPERTY OF LENOVO. ITS USE IS AUTHORIZED ONLY FOR RESPONDING TO A REQUEST FOR QUOTATION OR FOR THE PERFORMANCE OF WORK FOR LENOVO. ALL QUESTIONS MUST BE REFERRED TO THE LENOVO PURCHASING DEPARTMENT.</small>		TITLE: Waikiki_1.1 Ver. V3.04
LENOVO CONFIDENTIAL		VCC1R8A/VCC09RA(MAX8632)
		sheet 86 of 100 Wednesday, February 14, 2007

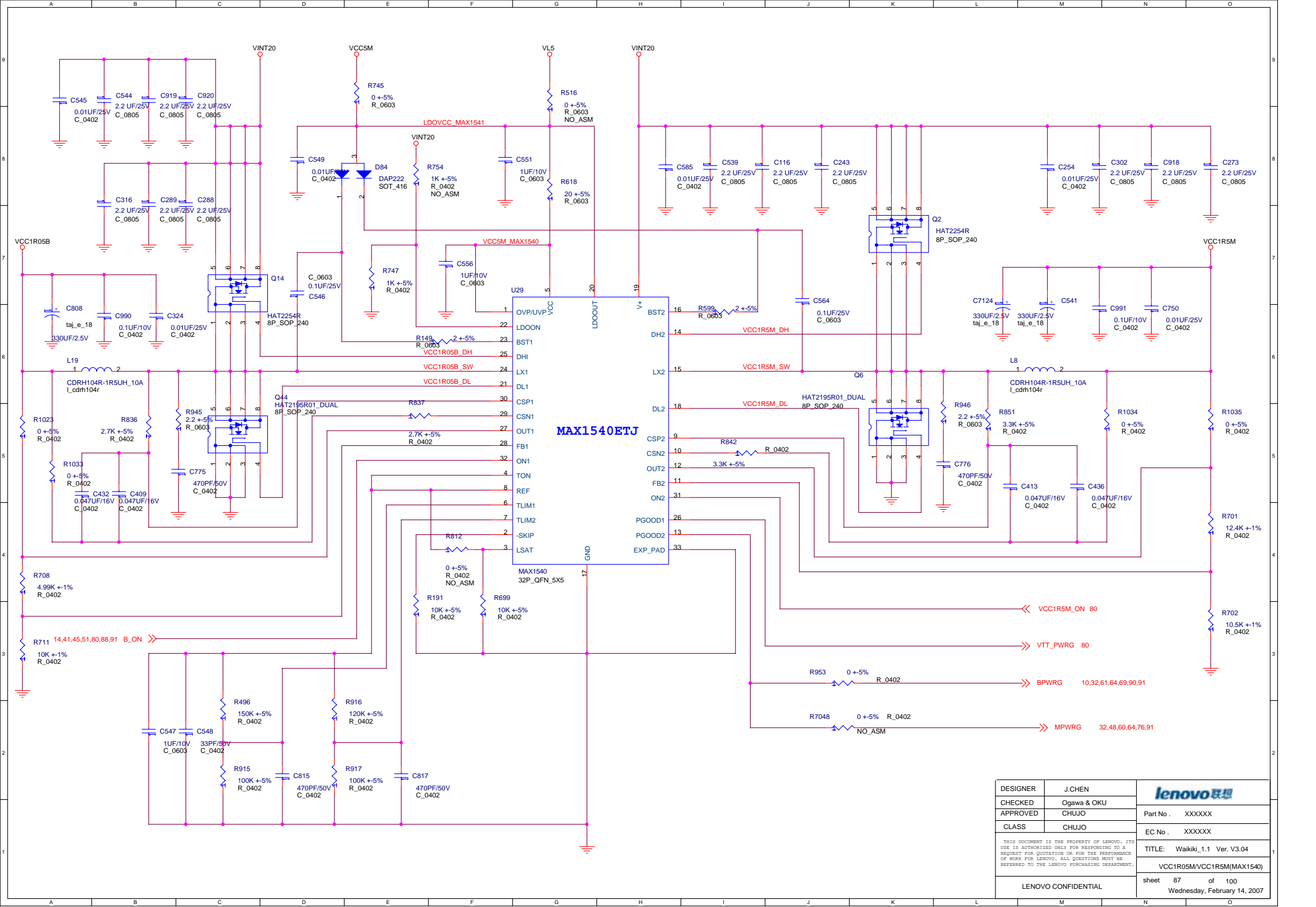

DESIGNER	J.CHEN	
CHECKED	Ogawa & OKU	
APPROVED	CHUJO	Part No. XXXXXX
CLASS	CHUJO	EC No. XXXXXX
THIS DOCUMENT IS THE PROPERTY OF LENOVO. ITS USE IS AUTHORIZED ONLY FOR RESPONDING TO A REQUEST FOR QUOTATION OR FOR THE PERFORMANCE OF WORK FOR LENOVO. ALL QUESTIONS MUST BE REFERRED TO THE LENOVO PURCHASING DEPARTMENT.		TITLE: Waiki_1.1 Ver. V3.04
LENOVO CONFIDENTIAL		VCC1R05M/VCC1R5M(MAX1540)
		sheet 87 of 100
		Wednesday, February 14, 2007

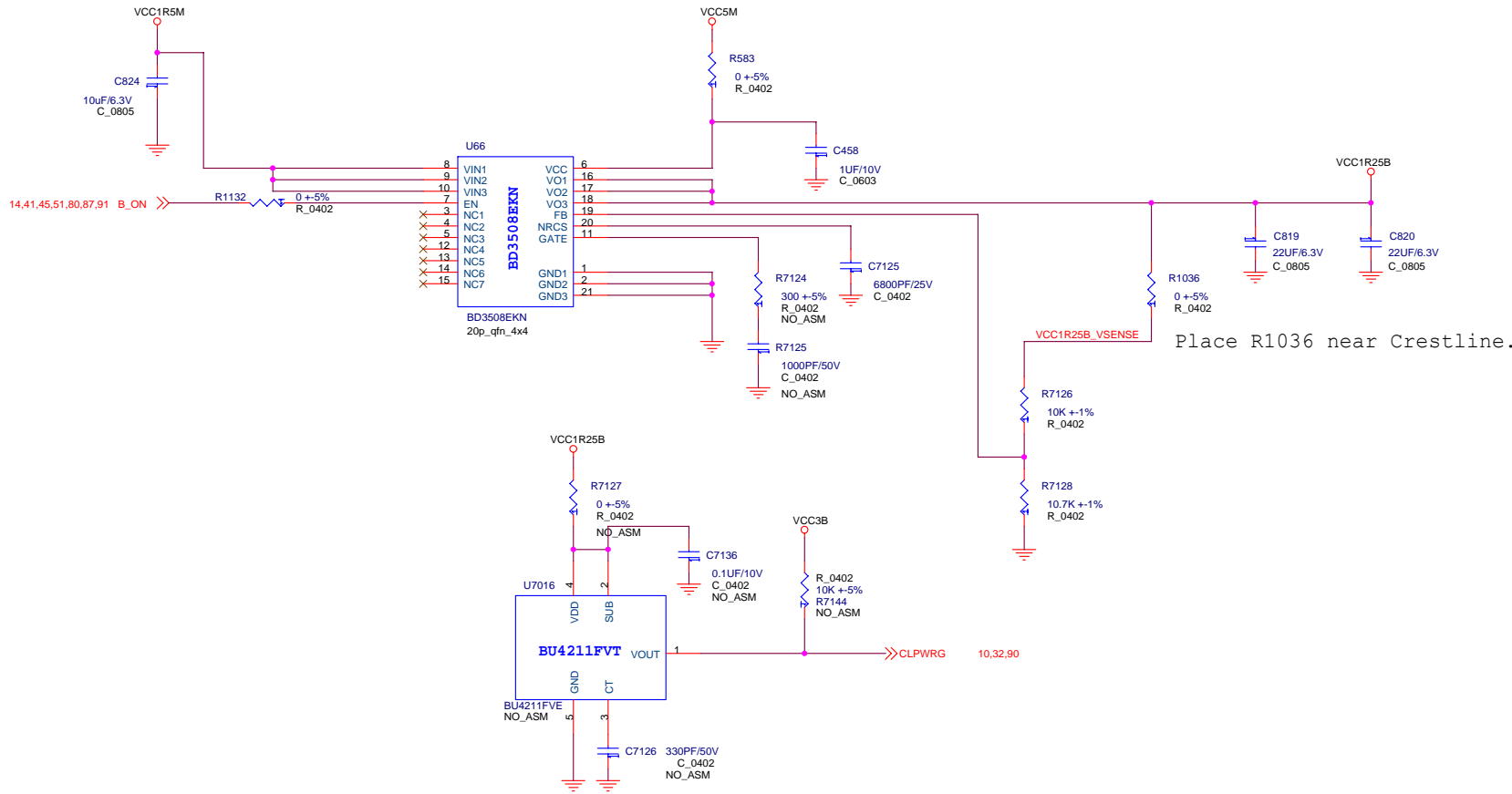

Place R1036 near Crestline.

DESIGNER	J.CHEN	
CHECKED	Ogawa & OKU	
APPROVED	CHUJO	Part No . XXXXXX
CLASS	CHUJO	EC No . XXXXXX
<small>THIS DOCUMENT IS THE PROPERTY OF LENOVO. ITS USE IS AUTHORIZED ONLY FOR RESPONDING TO A REQUEST FOR QUOTATION OR FOR THE PERFORMANCE OF WORK FOR LENOVO. ALL QUESTIONS MUST BE REFERRED TO THE LENOVO PURCHASING DEPARTMENT.</small>		TITLE: Waikiki_1.1 Ver. V3.04
		VCC1R25B(VT322)
LENOVO CONFIDENTIAL		sheet 88 of 100 Wednesday, February 14, 2007

BLACK PAGE

DESIGNER	J.CHEN	
CHECKED	Ogawa & OKU	
APPROVED	CHUJO	Part No . XXXXXX
CLASS	CHUJO	EC No . XXXXXX
<small>THIS DOCUMENT IS THE PROPERTY OF LENOVO. ITS USE IS AUTHORIZED ONLY FOR RESPONDING TO A REQUEST FOR QUOTATION OR FOR THE PERFORMANCE OF WORK FOR LENOVO. ALL QUESTIONS MUST BE REFERRED TO THE LENOVO PURCHASING DEPARTMENT.</small>		TITLE: Waikiki_1.1 Ver. V3.04
LENOVO CONFIDENTIAL		LOAD SW AMT
		sheet 89 of 100
		Wednesday, February 14, 2007

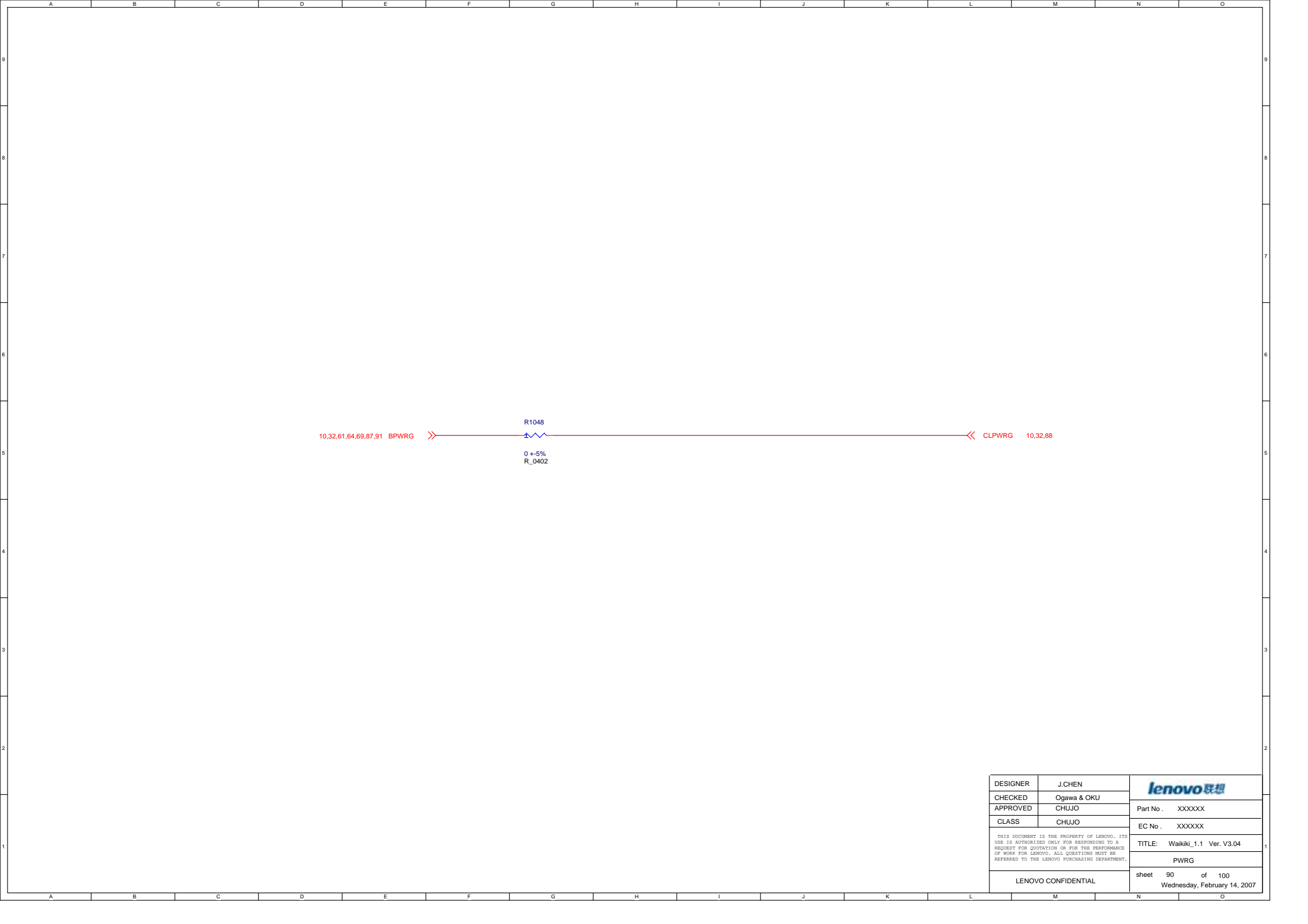

DESIGNER	J.CHEN	
CHECKED	Ogawa & OKU	
APPROVED	CHUJO	Part No . XXXXXX
CLASS	CHUJO	EC No . XXXXXX
<small>THIS DOCUMENT IS THE PROPERTY OF LENOVO. ITS USE IS AUTHORIZED ONLY FOR RESPONDING TO A REQUEST FOR QUOTATION OR FOR THE PERFORMANCE OF WORK FOR LENOVO. ALL QUESTIONS MUST BE REFERRED TO THE LENOVO PURCHASING DEPARTMENT.</small>		TITLE: Waikiki_1.1 Ver. V3.04
LENOVO CONFIDENTIAL		PWRG sheet 90 of 100 Wednesday, February 14, 2007

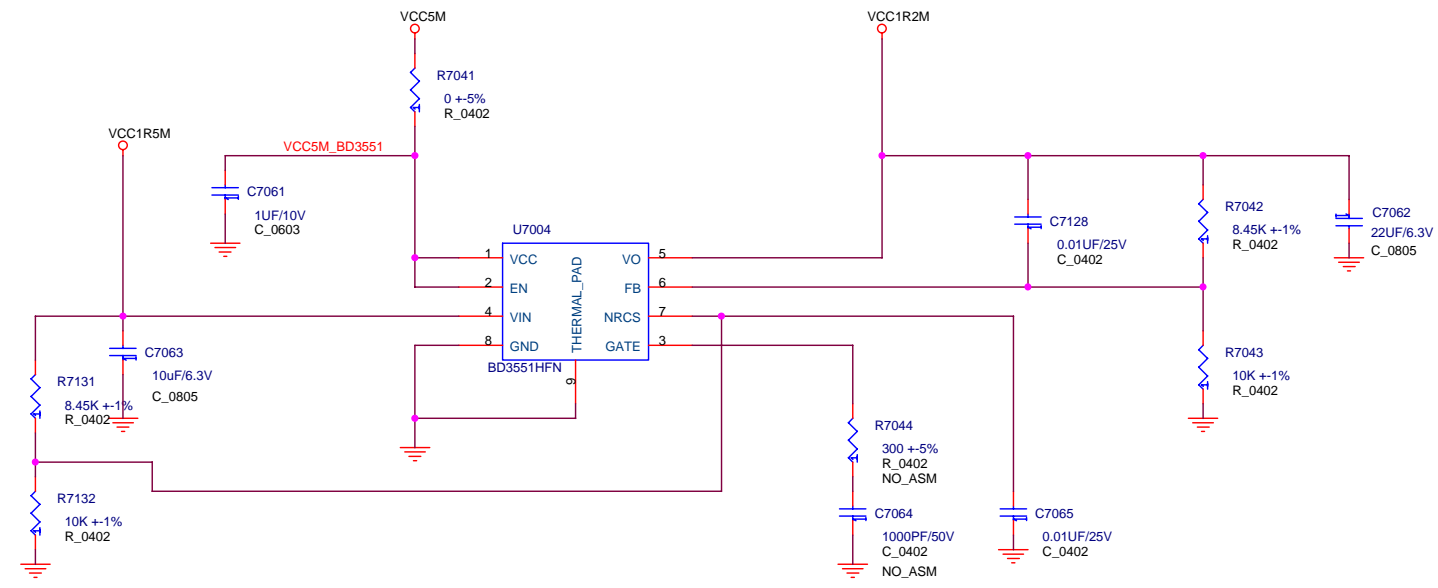
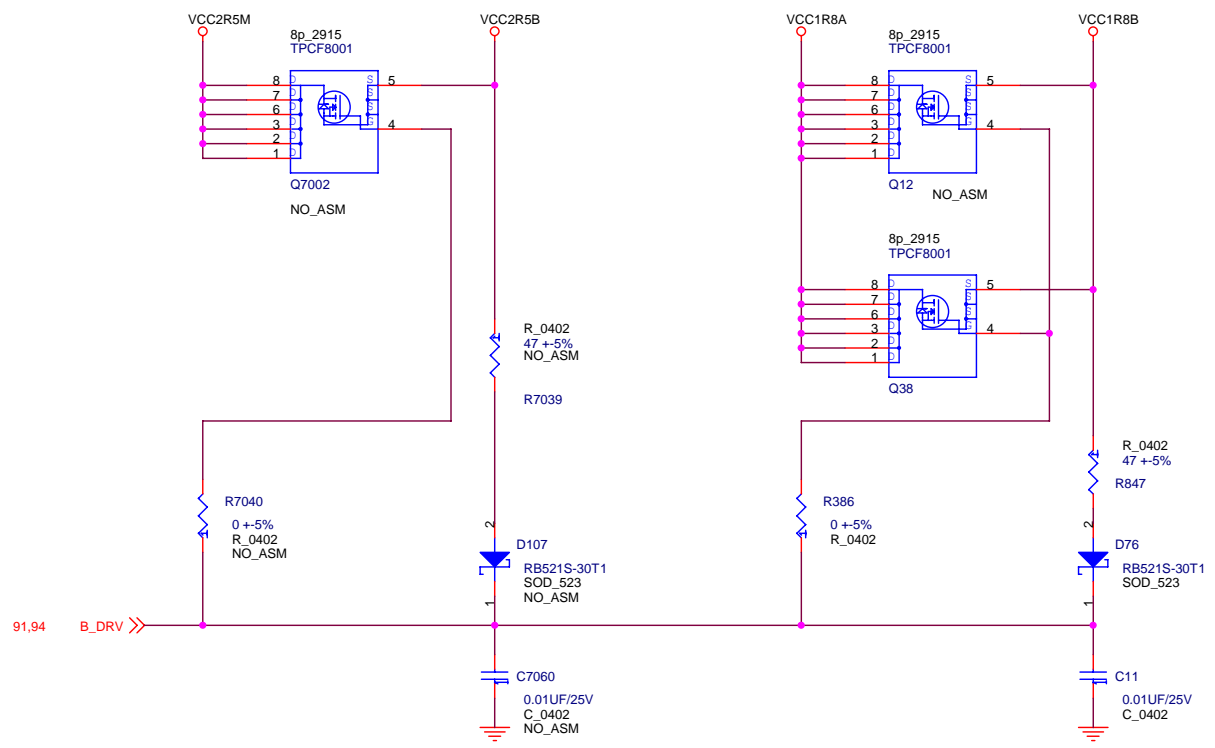

DESIGNER	J.CHEN	
CHECKED	Ogawa & OKU	
APPROVED	CHUJO	Part No. XXXXXX
CLASS	CHUJO	EC No. XXXXXX
THIS DOCUMENT IS THE PROPERTY OF LENOVO. ITS USE IS AUTHORIZED ONLY FOR RESPONDING TO A REQUEST FOR QUOTATION OR FOR THE PERFORMANCE OF WORK FOR LENOVO. ALL QUESTIONS MUST BE REFERRED TO THE LENOVO PURCHASING DEPARTMENT.		TITLE: Waikiki_1.1 Ver. V3.04
LENOVO CONFIDENTIAL		LOAD SW VIDEO
		sheet 92 of 100 Wednesday, February 14, 2007

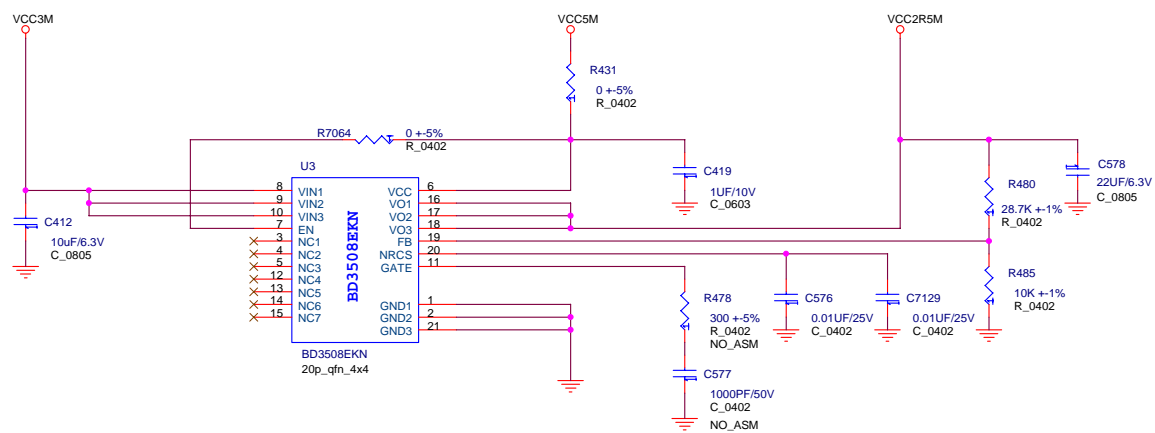

DESIGNER	J.CHEN	
CHECKED	Ogawa & OKU	
APPROVED	CHUJO	Part No. XXXXXX
CLASS	CHUJO	EC No. XXXXXX
<small>THIS DOCUMENT IS THE PROPERTY OF LENOVO. ITS USE IS AUTHORIZED ONLY FOR RESPONDING TO A REQUEST FOR QUOTATION OR FOR THE PERFORMANCE OF WORK FOR LENOVO. ALL QUESTIONS MUST BE REFERRED TO THE LENOVO PURCHASING DEPARTMENT.</small>		TITLE: Waikiki_1.1 Ver. V3.04
LENOVO CONFIDENTIAL		LOAD SW AUX1 AUX2
		sheet 93 of 100 Wednesday, February 14, 2007

	SWAP BAY	FIXED BAY
Q92	ASM	NO_ASM
R986	ASM	NO_ASM
R321	ASM	NO_ASM
D33	ASM	NO_ASM
C365	ASM	NO_ASM
R7096	NO_ASM	ASM

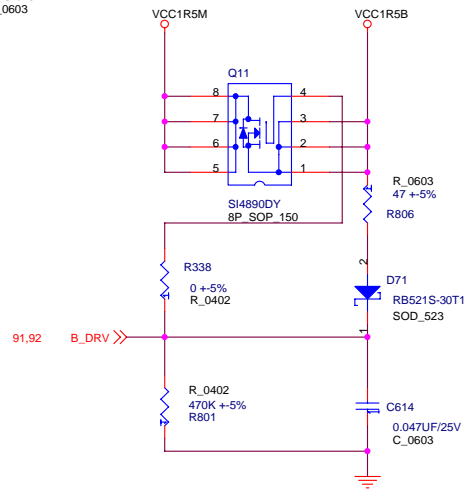
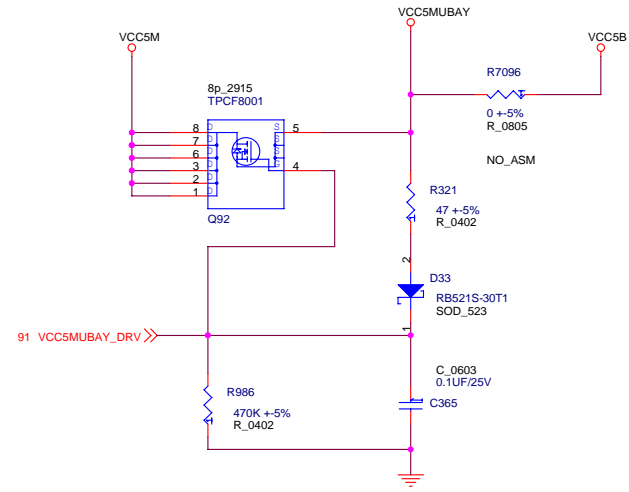
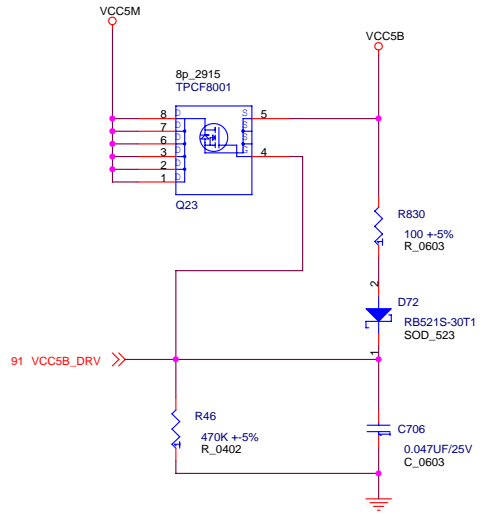
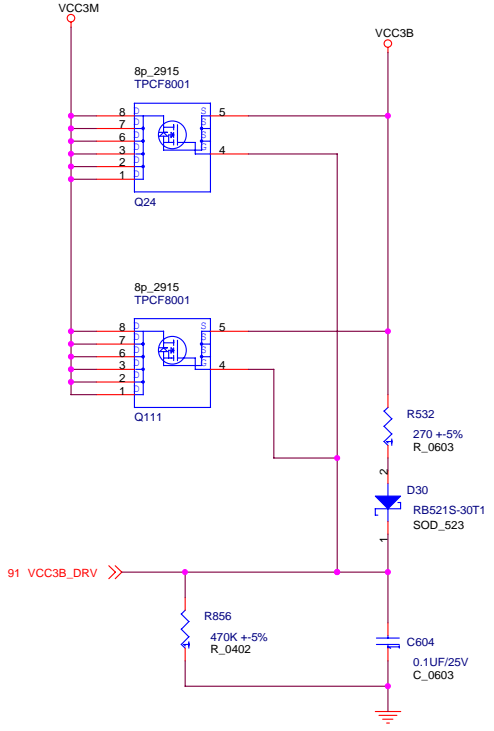

DESIGNER	J.CHEN	
CHECKED	Ogawa & OKU	
APPROVED	CHUJO	Part No . XXXXXX
CLASS	CHUJO	EC No . XXXXXX
<small>THIS DOCUMENT IS THE PROPERTY OF LENOVO. ITS USE IS AUTHORIZED ONLY FOR RESPONDING TO A REQUEST FOR QUOTATION OR FOR THE PERFORMANCE OF WORK FOR LENOVO. ALL QUESTIONS MUST BE REFERRED TO THE LENOVO PURCHASING DEPARTMENT.</small>		TITLE: Waikiki_1.1 Ver. V3.04
LENOVO CONFIDENTIAL		LOAD SW B&UBAY
		sheet 94 of 100 Wednesday, February 14, 2007

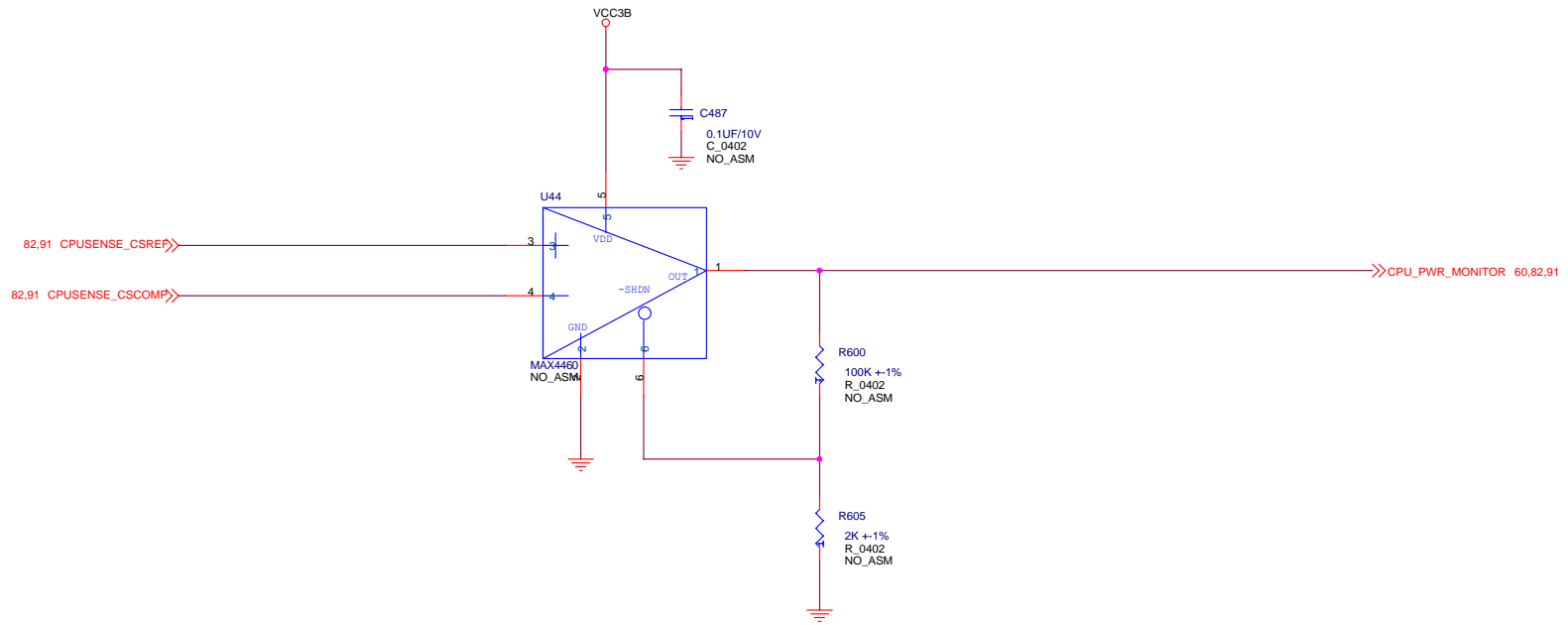

DESIGNER	J.CHEN	
CHECKED	Ogawa & OKU	
APPROVED	CHUJO	Part No . XXXXXX
CLASS	CHUJO	EC No . XXXXXX
<small>THIS DOCUMENT IS THE PROPERTY OF LENOVO. ITS USE IS AUTHORIZED ONLY FOR RESPONDING TO A REQUEST FOR QUOTATION OR FOR THE PERFORMANCE OF WORK FOR LENOVO. ALL QUESTIONS MUST BE REFERRED TO THE LENOVO PURCHASING DEPARTMENT.</small>		TITLE: Waikiki_1.1 Ver. V3.04
LENOVO CONFIDENTIAL		POWER MONITOR
		sheet 96 of 100 Wednesday, February 14, 2007

PTH FOR SCREW HOLE

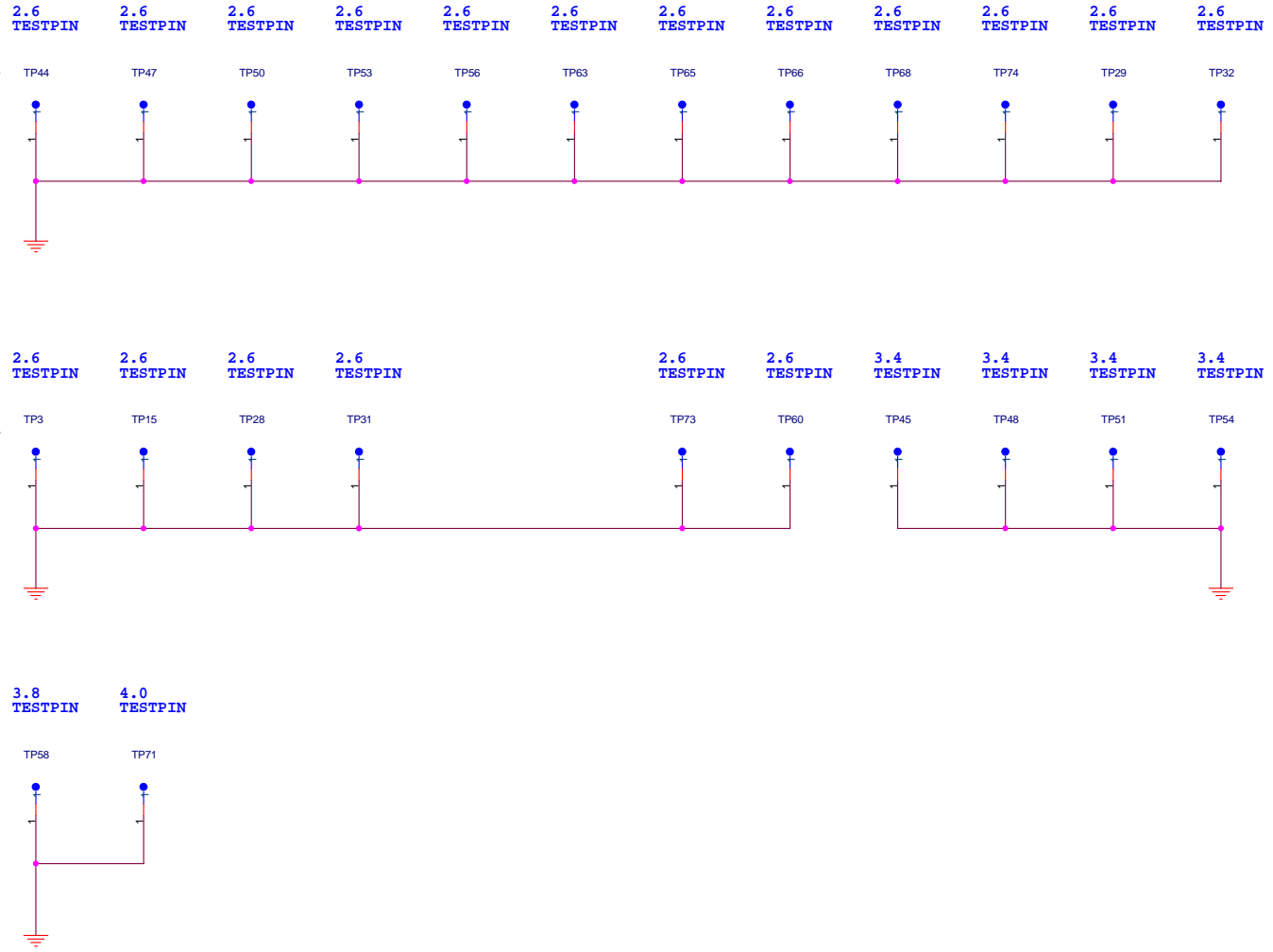

DESIGNER	J.CHEN	
CHECKED	Ogawa & OKU	
APPROVED	CHUJO	Part No . XXXXXX
CLASS	CHUJO	EC No . XXXXXX
<small>THIS DOCUMENT IS THE PROPERTY OF LENOVO. ITS USE IS AUTHORIZED ONLY FOR RESPONDING TO A REQUEST FOR QUOTATION OR FOR THE PERFORMANCE OF WORK FOR LENOVO. ALL QUESTIONS MUST BE REFERRED TO THE LENOVO PURCHASING DEPARTMENT.</small>		TITLE: Waikiki_1.1 Ver. V3.04
LENOVO CONFIDENTIAL		PTH SCREW HOLES
		sheet 97 of 100 Wednesday, February 14, 2007

EC History List

SDV Phase ----->

EC#	PAGE	Description
WK_SDV_EC001	20	R341 & R27 : 2.2K => 4.7K for DVI ID read fail W /A EC; SDVO_CTRL_DATA/CLK Pullup value change.
WK_SDV_EC002	88	R598 : 47K 5% => 43.2K 1%,C819 & C820 : 22UF => 10UF/6.3V/10%/2125, to correct value of VCC 1R25AMT
WK_SDV_EC003	10	R184 : ASM=>NO ASM,to set default to LOW POWER PCIE (same as DaV -1-Integ/Disc, DaV-3-Disc)
WK_SDV_EC004	12	C762 : 0.1UF => 0.47UF/6.3V/10%/1005,C681, C683 : 0.1UF => 0.22UF/6.3V/10%/1005, C733 : 0.1UF => 2.2UF/6.3V/10%/1608, C579 : 10UF =>2.2UF/6.3V/20%/2125, C580 : 10UF => 4.7UF/6.3V/10%/2125,to meet Intel Design Review results
WK_SDV_EC005	84	R829 : 6.19K 1% 1005 to adjust voltage of VCC 1R05M
WK_SDV_EC006	48	Change R1005 from pull down to pull up in order to support MS card
WK_SDV_EC007	60	R939 ASM(100kΩ) -> No ASM
WK_SDV_EC008	63	R690 : NOASM => 100K ASM,Add 100Kohm pulldown to PANEL_POWER_ON (to meet Intel D.G)
WK_SDV_EC009	45	R908 : 27K => 16.2K/1%/1005,to change MICVCC from 4.7V to 3.3V for AD1984
WK_SDV_EC010	32	R345 ASM -> NO_ASM (0ohm),R1009 NO_ASM -> ASM (0ohm, 83G3823) to enable GbE Disabling from BIOS Setup Menu
WK_SDV_EC012	28	Remove Q108 and nets to remove Security LED Completely
WK_SDV_EC013	22	Q45 : Change NchMOSFET from 2SK3019 to 2SK3541
WK_SDV_EC014	11	Add R772 100K/1% pulldown resistor to VGA_BLON (to meet Intel D.G)
WK_SDV_EC015	59	Add C764,C879,C880,C881,(1000pF x 4) at audio lines near the Dock connector.
WK_SDV_EC016	75	Add C882 100pF at ACDC_ID near the DC connector(J24)
WK_SDV_EC017	75	Add Q91,Q97,R773 to prevent inrush current from AC adapter to Battery
WK_SDV_EC018	75	Change placement note of R11 and R264 in order to prevent connection with VINT 20
WK_SDV_EC019	85	Remove Q15,R403,R425,R429,R521,R537,R538,R540,R579,R586,R587,R590,R602,r73 change R494 to 22K 5%, ASM, Change R501,R541,R519,R549,R520 from No_ASM to ASM, for GFX_VID PULLUP W/A until BIOS start for Crestline ES1, ES2(Parmanent EC)
WK_SDV_EC020	44	Delete R1014,R1015, R1017, R1018, This resiser prevent to on these FET due to low voltage level.
WK_SDV_EC022	61	Add R943 100K 5% pullup
WK_SDV_EC023	14	Change Cap. Parameter C204,C205,C205 from 10V 10% TO 6.3V, 10%
WK_SDV_EC024	12	ADD C883,C884,C885,C886,C887,C888, AND Remove C734,C735,C736, FOR Add de-cap to VCCGFXCORE
WK_SDV_EC025	19	Change C732,C672,C673,C213,C739,C708,C716 to NO_ASM, and change R335,R336,R76 to 1 Ohm to follow supplier 's recommendation
WK_SDV_EC026	28	Change R668 to NO_ASM and R764 to ASM, because GMCH PWM problem was fixed by BIOS correction
WK_SDV_EC027	88	add five 0 ohm resistors: R1053,R1054,R403,R425,R429 in order to follow AMT NON Support
WK_SDV_EC028	26,27	Insert two blank pages between Page 26 and Page27.
WK_SDV_EC029	52,56,59,74	Add Docking BOM Option Tables
WK_SDV_EC030	63	Add R540,R579, 0 Ohm NO_ASM for no Touch Pad support
WK_SDV_EC031	65,67	Change R305,C293,J26 to NO_ASM for no Legacy IO
WK_SDV_EC032	37,94	Add R586,R587, and add FixedBay or SwapBay BOM Option tables
WK_SDV_EC033	73	Change Q97 from DTC115EE to DTC114EE.
WK_SDV_EC034	19	Change C672 C213 to NO_ASM
WK_SDV_EC035	69,91	Change Q59.3PIN from PWRSHUTDOWN to -SHUTDOWN,add net -SHUTDOWN on U61.16PIN for to divide -pwrshutdown signal into IN and OUT
WK_SDV_EC036	28,32,61	Del GPIO_BT signal and add -S4_STATE signal between H8 and ICH8 for detect S4 state.
WK_SDV_EC037	94	Change Q11 from HAT2195R01 to Si4890DY for cost reduction
WK_SDV_EC038	29,74	Change RGB signal CAP C448, C449, C596,C648, C651, C653 from 10pF to 22pF.
WK_SDV_EC039	32	Change R79 from 100ohm 5% to 39ohm 5% to improve waveform of -PLTRST_FAR
WK_SDV_EC040	85	Change R462 =>ASM,R595 100K=>200K,C744=>ASM,C895 2200PF=>1800PF,R905 59K=>43.2K,C660 =>NO_ASM,L23 0.88uh=>0.56uh for meet INTEL GMCH SPEC.
WK_SDV_EC041	78,81	CHANGE C722 0.01uF 25V 1005 10%,C214 C520 C386 C272 C324 C549 C750: 0.01uF 25V 1005 10% in order to reflect cap.
WK_SDV_EC042	86	Change R330 =>NO_ASM,R685 150K=>100K,Q43,Q49 =>HAT2195R01_DUAL in order to raise OCP point and output voltage of VCC 1R8M for DDR2
WK_SDV_EC043		Delete AMT support circuit,Include change AMT power rail to B power rail,modify AMT signal,detail information please see EC_FOR_AMT_DISABLE_2.PDF
WK_SDV_EC044	63	ADD TouchPad/FingerPrint Support information.
WK_SDV_EC045	78,79,80	ADD SWAP BAY/FIXED BAY BATTERY option information when built bom
WK_SDV_EC046	11,14	Add ASM/NOASM table for S -Video support when built bom.
WK_SDV_EC047	11	change R253 from 1.3K to 1.27K, 0.5%
WK_SDV_EC048	80	change R507 from 12K to 24K,and change R507 to R7035
WK_SDV_EC049	91	R855 change to NO_ASM, R852 chang to 49.9K 1%, change R855 to R9036
WK_SDV_EC050	32	Add Cardbus ID
WK_SDV_EC051	53,71	Add R7034, 200ohm, chang C591(C7051) to 0.1UF, 1V, 10%, change C301(C7059) to 0.01UF, 25V, 10%
WK_SDV_EC052	61	Change H8 pin assign of S4_STATE#
WK_SDV_EC053	72	Change default APS logic for ADXL322.
WK_SDV_EC054	32	Change to Waikiki ID from Davinci ID, R1021 NO_ASM to ASM, and R1038 ASM to NO_ASM
WK_SDV_EC055	32	Planar ID 0000b for SDV, R113 NO_ASM to ASM, and R672 ASM to NO_ASM
WK_SDV_EC056	45	Co-Layout Headphone amplifier AN12946A
WK_SDV_EC057	45	Replace Ethernet from Nineveh to BCM 5787M (U7002).

EC#	PAGE	Description
WK_SDV_EC058	46	Change system speaker function with BEEP.
WK_SDV_EC059		Add comments for rating of power components.
WK_SDV_EC060	42	C7002 : should be 4.7uF 10V XSR,Q99 : 2SK3541 -> DTC115
WK_SDV_EC061	61,32	Delete 0ohm jumpers and connect directly of H8,and Delete NETDETECT signal.
WK_SDV_EC062	70	Change from DI to R7052 0ohm and Delete R212.
WK_SDV_EC063	48	To remove hook for R5C584, and circuit for 2nd port of IE6E1394 termination and non-internal regulator
WK_SDV_EC064	48	To update ASM option for IE6E1394 support case(R5C847, R5C803) and non support case (R5C804)
WK_SDV_EC065	32	Pull-up R272 for CL_RST_WLAN# -> NO_ASM : Intel's recommendation
WK_SDV_EC066	31	Add 4in1 Slot Presence Detection ID.
WK_SDV_EC067	48	To implement feedback of Circuit review by Ricoh
WK_SDV_EC068	60	ADD RC circuit for fix G-sensor noise problem
WK_SDV_EC069	70	DEL C41 to remove stub of LPCCLK for TATER
WK_SDV_EC070	81	ADD R7051 R7052 in order to support MAX17003 for Discharge function of VCC3M and VCC5M
WK_SDV_EC071	91	ADD R7045 DEL R868,R820,R876,R900 for change RINKAN-1 circuit for correction.
WK_SDV_EC072	70	Change TC7WB125FK to TC7SB384FU,TC7WB126FK to TC7SB385FU due to cost reduction
WK_SDV_EC073	55	Change C626,C627 to 0402.
WK_SDV_EC074	59,61	Change F14 : ASM -> NOASM,C7073,C7074,C7075,C7076 from 470pf to 330pf.
WK_SDV_EC075	76	Change C99,C90,C233 from 1uF/16V -> 1uF/10V in order to reflect cap.
WK_SDV_EC076	86	U7.5 add MPWRG signal workaround for backup
WK_SDV_EC077	55	Remove MDI_DETECT circuit and Change the power source of Magnetics from VCC1R8AUX to VCC2R5M.
WK_SDV_EC078	53	Modify NVRAM strapping and Connect ENERGY_DET to MDI_DETECT.
WK_SDV_EC079	53	Change BCM power source and add some decoupling Cap.
WK_SDV_EC080	53	VMAINPRNST connects VCC3B through R7029,LOW_PWR connects -GBE_DISABLE,Add 0ohm on LAN_XTALI.
WK_SDV_EC081	92	Add VCC1R2M Logic for Broadcom BCM5787M support
WK_SDV_EC082	93	Add VCC2R5M Logic for Broadcom BCM5787M support
WK_SDV_EC083	86,87,91,93	Delete VCC1R8AUX and VCC1R8M,ADD VCC1R8A.
WK_SDV_EC084	72	Make device option for G-SENSOR.
WK_SDV_EC085	32	Follow EC043 correct some signal.
WK_SDV_EC086	92	Del Q86 for del VCC3VIDEO power.
WK_SDV_EC087	32,64	ADD -PHY_PD_ICH signal then use it and -GBE_DISABLE to generate AUX_ON.
WK_SDV_EC088	7	Del R135,R387.
WK_SDV_EC089	64	Change SPI interface signal jumper resistor from 0 ohm to 33 ohm.
WK_SDV_EC090	85	Add pull-down resistor on Gfx_VID signal.
WK_SDV_EC091	11	change R772 to 100k +-5%,change R7071/R7072 to 33 +-5% for cost reduce.
WK_SDV_EC092	38	change FL7 to ACM2012-900-2P,R650/651 to 0 ohm 0603.
WK_SDV_EC093	10	Add R7073/R7074 on GFXCORE_ON signal for INTEL comment.
WK_SDV_EC094	50	Change PCMCIA Slot to new one.
WK_SDV_EC095	80,93	Change Q12.1 to VCC1R8A,add R7064 0ohm between U3.7 to U3.6,del R373 and VCC1R8M_ON
WK_SDV_EC096	53	Correct the broadcom lan circuit,like change Ferrite bead to bigger type.
WK_SDV_EC097	31,32,64	Terminate opened pin and unused pin on ICH8M, and del -GBE_DISABLE net.
WK_SDV_EC098	84	Delete of VCC1R05M power rail.
WK_SDV_EC099	84	Change assignment of PC card slot connector.
WK_SDV_EC100	19,33,54	Modify PCIE interface of BCM5787M,remove Robson interface.
WK_SDV_EC101	63	Del C631 and C636 on the FPR USB lines.
WK_SDV_EC102	54,57	Add bypass capacitors for VCC3B at miniPCIE slots.
WK_SDV_EC103	32	Change R7006 from NO_ASM to ASM.
WK_SDV_EC104	52,53,54,57	Change MID* netname to MDI* ,correct PCIE slot connect,add Lan eeprom table.
WK_SDV_EC105	37	Del CD_IN function on ODD.
WK_SDV_EC106	23	Change R7083 to 130 ohm,D7006 to SML_A10MT.TC7WB125AFK to TC7SBL384AFU.
WK_SDV_EC108	32	Correct 4_in_1 slot ID.
WK_SDV_EC109	91	Enable Rinkan_1 -LPMORE function.
WK_SDV_EC110	53	Follow WK_SDV_EC096. Add strap option for Broadcom.
WK_SDV_EC111	50	Delete VCC3_MC at PC card slot.
WK_SDV_EC112	23	Add comments for xd function route.
WK_SDV_EC113		Location ID to be consistent to DaVinci-3.Only change Location IDs . NO CHANGE in connection in schematics.
WK_SDV_EC114	86	Change L11 to CDRH104R_1R5UH_10A follow DV3.
WK_SDV_EC115	31,53	Connect LAN_RSTSYNC on ICH8 to GND, and modify LAN strapping table.

DESIGNER	J.CHEN	
CHECKED	Ogawa & OKU	
APPROVED	CHUJO	Part No . XXXXXX
CLASS	CHUJO	EC No . XXXXXX
THIS DOCUMENT IS THE PROPERTY OF LENOVO. ITS USE IS AUTHORIZED ONLY FOR RESPONDING TO A REQUEST FOR QUOTATION OR FOR THE PERFORMANCE OF WORK FOR LENOVO. ALL QUESTIONS MUST BE REFERRED TO THE LENOVO PURCHASING DEPARTMENT.		TITLE: Waikiki_1.1 Ver. V3.04
LENOVO CONFIDENTIAL		EC History 1
		sheet 98 of 100 Wednesday, February 14, 2007

EC History List 2

EC#	PAGE	Description
WK_SDV_EC0116	45,46,61	Add beep enable circuit and correct connection.
WK_SDV_EC0117	53	Add pull-up resistor R7097 for EEPROM WP signal.
WK_SDV_EC0118	23	Change J29 to Tyco from FOXCONN.
WK_SDV_EC0119	85	Correct discription.
WK_SDV_EC0120	85	Change R7062 rename to R212.
WK_SDV_EC0121	86	Del R17 and not connect MPWRG on U7.5 PIN
WK_SDV_EC0122	23	Correct slot pin.
WK_SDV_EC0123	38	R650/R651 marge to 1 network resistor RN5.
WK_SDV_EC0124	52,53,55	Change pin definition of T1/T2/U12.
WK_SDV_EC0125	61	Change RN54 to discrete resistor .
WK_SDV_EC0126		Parameter change and Error Correction.
WK_SDV_EC0127	84	R598,R601,C819,C820 Part value change.
WK_SDV_EC0128	58	DEL U53,U6 function for Live SPI rom one chip only.
WK_SDV_EC0129	95	No asm R996,Q64 change LPMODE EC.
WK_SDV_EC0130	52	ADD C637 ASSEMBLE STATION ON TABLE.
WK_SDV_EC0131	45	Move Panasonicamplifier from planar layout to dummy subcard.
WK_SDV_EC0132	36	BOM change,J1 change to HAS1-2DFB12-51K.
WK_SDV_EC0133	81	BOM change,ADP3209 update to X5 version.
WK_SDV_EC0134	81	Change C482 to R1072 for use ADP3209 X5.
WK_SDV_EC0135	61	Change R1042 to 10K 5%.
WK_SDV_EC0136	91	Change C609 1U 0603 to 2.2U 0805 for prevent power shutdown when AC Adapter attached.
WK_SDV_EC0137	41	Disconnect U8 centerpad from AGND.
WK_SDV_EC0138	53	Add test point to U8 pin4,8,9.
WK_SDV_EC0139	52	RC termination should be NO_ASM.R611, R613, R615, R661, R610, R612, R660, R614, C528, C532, C527, C529 -> NO_ASM
WK_SDV_EC0140	56	Please stuff the TVS diode D103,D104 of Ethernet.
WK_SDV_EC0141	53	Change U7003 to 24C64 for the evaluation on DV4.After the evaluation without any issue, we plan to use 24L01 for Volume production to reduce the cost.stuff R7075 R7077, no asm R7076 R7078.
WK_SDV_EC0142	45	Change R655,R833,R700,R66 to 47K 5%,R67 No_asm.
WK_SDV_EC0143	85	Change ADP3209 X5 P/N to #DV3190.
WK_SDV_EC0144	72	Update logic table to support new G_sensor ST Micro LIS244AL.
WK_SDV_EC0145	85	Update L23 to #DV3127 SPM10040T-R56M150
WK_SDV_EC0146	85	Update L11 to #DV3014
WK_SDV_EC0147		Update #DV3123 description to CHIP 0.6UH +/-20% 8.2A SMT 2PIN .
WK_SDV_EC0148		Just correct/update description of schematic.
WK_SDV_EC0149	23	Change J29 P/N to 42W3121.
WK_SDV_EC0150		BOM correction /update
WK_SDV_EC0151		BOM correction /update
WK_SDV_EC0152		Correction of Schematics description
WK_SDV_EC0153		Change C11 from 0.01uF to 0.022uF for Capacitance of B_DRV being 0.05uF
WK_SDV_EC0154		to change Integ GFXCORE DC-DC in order to meet Intel GMCH spec.
WK_SDV_EC0155	91	Change R72 to NO_ASM to prevent power shutdown problem when AC is attached.
WK_SDV_EC0156	46	Change R984 to 10k 5%.
WK_SDV_EC0157	85	Change R905 from 59k to 43.2k for shortstage of factory.
WK_SDV_EC0158	59	F14 NO_ASM to ASM,41A9437

AMOM Phase ----->

EC#	PAGE	Description
WK_AMOM_EC001	32	Planar ID : 0000b -> 0001b.R671 : NOASM -> ASM,R114 : ASM -> NOASM
WK_AMOM_EC002	23	Correction design symbol of 4-in-1 slot,MemoryStick signal assignments were reversed.
WK_AMOM_EC003	70	Add logic to fix 187 error.Use location ID Q113 for 2SK354land Q114 for DTAll4E6A for consistency with Coronado-3.
WK_AMOM_EC004		Correction Layout design error in SDV
WK_AMOM_EC005		Correct design error as symbol of MMBT3904WT1 in SDV
WK_AMOM_EC006	32	Add 100k ohm pull-up to VCC3M at GPIO12 of ICH8M.
WK_AMOM_EC007	53	Add 0ohm R7115 tie-down resister at pin#11 of U7002
WK_AMOM_EC008		EC for Modem,include Add modem DAA logic, delete UWB slot, delete WPAN LED logic, delete MDC Connector
WK_AMOM_EC009	28	Change power source F16 for USB camera from VCC 5B to VCC3B.
WK_AMOM_EC010	32,65,67	DEL Legacy I/O support. Del R305,Q86,R214,J26,and add R7118.
WK_AMOM_EC011	39,40,41,42,43,45,46	EC for Audio portion of AMOM.
WK_AMOM_EC012	39	Pull up U7014 pin RCOSC to VCC3M for wake up event.
WK_AMOM_EC013	47	Modem connector change to same as RTC battery connector.

V1.50 (2006/10/24)

WK_AMOM_EC014	39	Add R7111 39.2k for enable speaker channel.
WK_AMOM_EC015	47	Add modem connector to follow Conexant design.
WK_AMOM_EC016		Silkscreen:"KONA-A"-->"KONA-B".
WK_AMOM_EC017		ADD insulation sheet to BOM.
WK_AMOM_EC018	45	DEL Panasonic amplifier circuit.

SIV Phase ----->

EC#	PAGE	Description
V2_00 (2006/11/16)		
WK_SIV_EC001	52	Planar ID : 0001b -> 0010b
WK_SIV_EC002	48,49	Change R5C847 to revised part (Ricoh P/N : R5C847-CSP208Q, Lenovo P/N : #DV3209)
WK_SIV_EC003	93	Add Cap C7129 0.01uF to NRCS pin of BD3508 for no overshoot of VCC 2R5M.
WK_SIV_EC004	92	Add tracking circuit to BD 3551HFN for no overshoot of VCC 1R2M.
WK_SIV_EC005	81	Add level shift circuit (3.3V -> 5V) to ""-PM_SLP_S3""(High Level 3.3V) in order to meet Skip functionspec of MAX 8744 IC.
WK_SIV_EC006	32	To change VCC1R25B DC-DC Switching -> LDO for Cost reduction
WK_SIV_EC007	81	No asm MAX8744 discharge circuit
WK_SIV_EC008	90	Add c7127 0.033uF 1005 to CLPWRG circuit in order to terminate an unexpected pulse,and change digital-transistor to 2SC4617.
WK_SIV_EC009	88	- to correct "DAV3_SIT_EC057".
WK_SIV_EC010	14	VCCA_CRT_DAC, VCCA_TV_DAC Power is changed to Linear Regulator (3.3V, 300mA)
WK_SIV_EC011	32	in order to improve efficiency of VCC5M and VCC3M during Power-on low power mode
WK_SIV_EC012	85	to change R691,R716 resistor size for downsizing.
WK_SIV_EC013	20	Add C631 on net SDVO_CTRLDATA for reduce noise.
WK_SIV_EC014	49,50	Follow RICOH review to change C218,C226,C415. To add Drive signal name on each DC-DC
WK_SIV_EC015	57	To add 10uF cap. for VCC3B of PCIe Cards (No-ASM)
WK_SIV_EC016	70	Add D7013,R7133 to fix voltage leakage from VCC3M to VCC3AMT,and add eeprom for asset ID option circuit.
WK_SIV_EC018		to change maker P/N because of EOL Page76 Q4 : FDS6990A -> FDS8978 (Fairchild) Page59 Q85, Page75 Q34 :SI4435ADY -> SI4435BDY.
WK_SIV_EC019	32,62	To add SLP_S5# to H8 for AMT function
WK_SIV_EC020		"WK_SIV_EC020 To add BEFCD0D21MX (2V 220uF 15mΩ) Panasonic on BOM as an alternative of C67# C262# C743C760 C945# (77P1928)."
WK_SIV_EC021	28	Add capacitor C23 between -BDC_PRESENCE and GND.
WK_SIV_EC022	14	1)MOW WW39 VCCD_QDAC Design change.2)GMCH-H/VSINC 33=>30 R change.3)Intel Review decap change to 0.001uF
WK_SIV_EC023	29	H/VSYNQ to CRT L25,L24 change to 30ohm resistor.
WK_SIV_EC024	10	GFXCORE_ON Pullup R73 change to 30K ohm
WK_SIV_EC025	85	GFXVID2 Pullup R494.2 change to VCC3B
WK_SIV_EC026	34	to change AMT power architecture for power reduction
WK_SIV_EC027	12	Add 22uF Cap.C7130 to VCC1R8A near Crestline (Intel Recommendation)
WK_SIV_EC028	82	to change C190= 390PF 10% 1005 in order to meet the requirement of GM
WK_SIV_EC029	14	to change C690, C725 from 470uF to 220uF.
WK_SIV_EC030	42	To add ESD protection on audio jack for new ESD standard as NO ASM.
WK_SIV_EC031	97	Change J20(OG_363040) to NO ASM.
WK_SIV_EC032	30,31	change pull-up RN on PATA bus
WK_SIV_EC033	20	to change C631 from 56pF to 68pF and change R341 from 4.7K to 5.6K for W/A for DVI detection fail withROM 18, 19, 20WW."

V2_01 (2006/11/21)

WK_SIV_EC034	70	Delete WATER chip (AT8356908),Add new TPM chip WPCT200WG,U46 and nearby parts : NOASM -> ASM
WK_SIV_EC035	81	to change from MAX8744 to MAX17003
WK_SIV_EC036	31	Add pull down R7141 to un-used GPIO pin
WK_SIV_EC037	97	Delete Hole (TP34 & TP35) and GND Pad
WK_SIV_EC038	81	Correction for WK_SIV_EC005
WK_SIV_EC039	88	Correction for WK_SIV_EC006
WK_SIV_EC040	85	Correction for WK_SIV_EC015
WK_SIV_EC041	29	follow up for WK_SIV_EC023
WK_SIV_EC042	6	Change C445, R476 and R477 on ITP interface to NO ASM.
WK_SIV_EC043	91	Change CLPWRG connection
WK_SIV_EC044	57	Delete SIM Socket,NOASM WWAN Socket
WK_SIV_EC045	20	NOASM DVI I/F chip CH7307C.
WK_SIV_EC046	31	Disconnect "-CPUSB" & "-CPPE" from ICH
WK_SIV_EC047	57	To add luF cap. for VCC3M and VCC1R5B of PCIe Cards

V2_02 (2006/11/23)

WK_SIV_EC048	01	to change R221 2.4K, R44 1.6K in order to adjust OCP point.
WK_SIV_EC049	95	to make all parts of Max power control(LPMODE) circuit NO_ASM because RINKAN-1 has this function inside.
WK_SIV_EC050	20	R27 : 4.7Kohm -> 3.9Kohm (NOASM)
WK_SIV_EC051	70	U31: Change to Lenovo P/N 41R0763 (Atmel AT975C3203-X5A30) Revision 1.2.D.05 from Lenovo P/N 41A1090
WK_SIV_EC052	47	Change AMoM components to Lenovo P/N
WK_SIV_EC053	91	in order to prevent to be applied over stress to input N-channel MOSFET Gate
WK_SIV_EC054	92	to no_asm VCC2R5B circuit and change C614 and C11 for DVI no_asm
WK_SIV_EC055	80	to elete VCC3VIDE0 circuit for not use.
WK_SIV_EC056	70	to Correction for WK_SIV_EC034
WK_SIV_EC057	88	Follow-up for WK_SIV_EC043
WK_SIV_EC058	57	Correction for WK_SIV_EC047,asm C7139 C7140.
WK_SIV_EC059		Change Audio AMP from MAX9789 to AN12946A.

DESIGNER	J.CHEN	
CHECKED	Ogawa & OKU	
APPROVED	CHUJO	
CLASS	CHUJO	EC No. XXXXXX
<small>THIS DOCUMENT IS THE PROPERTY OF LENOVO. ITS USE IS AUTHORIZED ONLY FOR RESPONDING TO A REQUEST FOR QUOTATION OR FOR THE PERFORMANCE OF WORK FOR LENOVO. ALL QUESTIONS MUST BE REFERRED TO THE LENOVO PURCHASING DEPARTMENT.</small>		
		TITLE: Waikiki_1.1 Ver. V3.04
EC History 2		
LENOVO CONFIDENTIAL		
		sheet 99 of 100 Wednesday, February 14, 2007

EC History List 3

EC# PAGE Description

V2.03 (2006/11/27)

WK_SIV_EC060 45 Audio AMP schematics Review Comment by Panasonic
 WK_SIV_EC061 81 Correction for WK_SIV_EC048
 WK_SIV_EC062 94 Correction for WK_SIV_EC054
 WK_SIV_EC063 Change VCC0R9A to VCC0R9B to reduce suspend power consumption
 WK_SIV_EC064 47 MBR1, MBR2 : Update Lenovo PN TMP-51 -> 41U5466
 WK_SIV_EC065 70 2 TPM solution dual lay.
 WK_SIV_EC066 27 Add check ponit card circuit.

V2.04 (2006/12/04)

WK_SIV_EC067 5 Add R7157 to support alternate source of U1.
 WK_SIV_EC068 19 Change some resistor fr each clk signal base on signal test.
 WK_SIV_EC069 97 Del J20(EMI finger)
 WK_SIV_EC070 39 ADD driver ability circuit for SPDIF
 WK_SIV_EC071 47 Follow Conexant advice add MJ4,MJ5.

V2.05 (2006/12/07)

WK_SIV_EC072 20 R72 change bigger to increase SPD High Voltage and decrease SPD Low Voltag at SPC setup timing
 WK_SIV_EC073 30 Change pull-up on PATA bus and change to ASM.□□□
 WK_SIV_EC074 19 BOM update : Clock Gen new revision (2 sources, alternate) on U2□□□
 WK_SIV_EC075 61 Change signal name to correct the polarity.□□□
 WK_SIV_EC076 46 Q15 ASM <- NO ASM□□□
 WK_SIV_EC077 65 Change P/N of NS SuperI/O to Winbond P/N□□□
 WK_SIV_EC078 91 Rinkan-1 Revision update (U61): Lenovo P/N may be changed □
 WK_SIV_EC079 56 BOM change J19: 42W3188 (JST, BM04B-SRSS-TBT (LF) (SN)) from 91P9290 (tyco, 1734595-4)□□□
 WK_SIV_EC080 76 to change R211: 12.7K -> 16.9K 0.5% in order to make -EXTPWR signal Low when 16V Adapter is attached.
 WK_SIV_EC081 Add ASM/NOASM table for TPM and integrated mic

V2.06 (2006/12/13)

WK_SIV_EC082 75 change R715 -> 270 5% 0603
 WK_SIV_EC083 56 BM04B-SRSS-TBT (LF) (SN) <- BM04B-SRSS-TBT (LFXSN)
 WK_SIV_EC084 Insulation Sheet, Bottom_CPU: 42W2759 from 42R9976
 WK_SIV_EC085 Lenovo P/N update:TMP-93 -> #DV3107 : R5C804,TMP-90 -> 38L5170 : PCA24S08D-T
 Rev:LATEST,TMP-98 -> #DV3254 : MAX17003EUT+
 WK_SIV_EC086 55 Add ASM/NO ASM table to page 55.
 WK_SIV_EC087 46 R66: 4.7k ohm 5% <- 47K 5%
 WK_SIV_EC088 53 tuning parameter for Y 7001

V2.07 (2006/12/15)

WK_SIV_EC089 Insulation Sheet 42W2759 from 42R9976
 WK_SIV_EC090 Add Dock/Audio asm table.

QS-DV6 Phase ----->

EC# PAGE Description

V2.50 (2007/01/05)

WK_QS_EC001 32 Planar ID : 0011b <- 0010b
 WK_QS_EC002 48 J28 : Change to Molex higher one.
 WK_QS_EC003 69 U4: MAX6602UE9A+ <- MAX6689,Delete C33/Q21/R404
 WK_QS_EC004 75 To change C72 -> 1000pF to reduce ringing voltage of DC-IN
 WK_QS_EC005 85 To change R595 from140K to 162K for VCCGFXCORE OCP adjustment.
 WK_QS_EC006 82 to change R746,R750 from 165K to 150K for VCCCPUCORE loadline adjusting ,to change R246 from 215k to 195k for VCCCPUCORE OCP adjusting.
 WK_QS_EC007 32 Correct Pull-up of R37 : VCC3M <- VCC3B
 WK_QS_EC008 34 To add 2.2uF Capacitor C7141 between VCCGLANPLL and GND. This is Intel's strong recommendation.
 WK_QS_EC009 23 J29 (4-in-1 slot) changes to improved one Lenovo P/N 42W3192 (tyco 1981456-1) from 42W3121
 WK_QS_EC010 61 Change R218,R7160 to indicate Thermal sensor ID.

V2.51 (2007/01/10)

WK_QS_EC011 BOM change to QS samples of Intel Chipset
 WK_QS_EC012 53 Broadcom EEPROM size change for Self -boot code
 WK_QS_EC013 61 Add pull-up R7161 for KBGA20# from Intel AMT workshop feedback
 WK_QS_EC014 48 Follow WK_QS_EC002: Apply to change 1394 connector to Molex 48126-1211
 WK_QS_EC015 69 Apply WK_QS_EC003 assessment
 WK_QS_EC016 32 Follow WK_QS_EC001 Update BOM: R114 -> NOASM, R671 -> ASM
 WK_QS_EC017 23 J29: #DV3283 (tyco 1989456-1) <- 42W3121
 WK_QS_EC018 86 To change R508 to 62K 5% 1/16W 1005 for VCC1R8A OCP adjusting.
 WK_QS_EC019 87 To change R149 from 1ohm to 2ohm for VCC1R05B ringing fail.to change R599 from 1ohm to 2ohm for VCC1R5M ringing fail.
 WK_QS_EC020 27 Del small debug card circuit.

V2.52 (2007/01/12)

WK_QS_EC021 48,49 U20: #DV3293 (Ricoh R5C847-CSP209Q(Lotcode 7Ax0FQ or later)) <- #DV3209
 WK_QS_EC022 82 to change R246 to 196K 1% for VCCCPUCORE OCP adjusting.
 WK_QS_EC023 23 J29: #DV3283 (tyco 1981456-1) <- tyco 1989456-1
 WK_QS_EC024 32 C7122 : 41A9849 1000pF 10% X7R 50V <- 04P9749 1000pF 10% X7R 25V
 WK_QS_EC025 65 U26 : 41R0755 (Winbond WPCN385LA0DG) <- #DV3104 (Winbond WPCN385CDG) 41R0755 doesn't support CIR.

V2.53 (2007/01/25)

WK_QS_EC026 87 To connect PGOOD2 to BPWRG to reduce the affection of VCC1R5M's undershoot.

SIT Phase ----->

EC# PAGE Description

V3.00 (2007/01/29)

WK_SIT_EC001 32 Planar ID chagne 0010b-->0100b
 WK_SIT_EC002 87 To connect "PGOOD2" to "BPWRG" to reduce the affection of VCC1R5M's undershoot.
 WK_SIT_EC003 31 Del comments.
 WK_SIT_EC004 29 To change RGB line's Beads value in order o minimize undershoot voltage.
 WK_SIT_EC005 53 Cut the SM BUS to Broadcom.
 WK_SIT_EC006 53 To support low_pwr mode of BCM5787M.
 WK_SIT_EC007 41 To separate bias voltage of mic amp from int mic.
 WK_SIT_EC008 For cost, change Lan EEPROM to 24C04.

WK_SIT_EC010 43,45 To adjust sound quality om microphone,to optimize Mute circuit

WK_SIT_EC011 81 To connect U41-22PIN to MPWRG for workaround of Toshiba Rinkan MPWRG problem.
 WK_SIT_EC012 5 To add second source of U1.

V3.01 (2007/01/30)

WK_SIT_EC013 52 Remove the temination for Ethernet.

V3.02 (2007/02/01)

WK_SIT_EC014 94 To change C706 to 0.047uf for quick ramp-up of VCC5B in order to delete a little of VR_PWRGD foR CPU CORE.
 WK_SIT_EC015 41 Add ASM/NOASM table for KONA config.
 WK_SIT_EC015 28 Change C313 to 41A1111 1UF/25V 0603.
 WK_SIT_EC016 Update ASM option table for waikiki_1.1_low and Kona-1.1.

V3.03 (2007/02/07)

WK_SIT_EC018 41 Follow WK_SIT_EC015,correct typo in description
 WK_SIT_EC019 86 To change comment of U7 to MAX8632.
 WK_SIT_EC020 51 U7003 : Lenovo P/N 41R0777
 WK_SIT_EC021 ADD revised R5C804 in Kona-1.1 BOM
 WK_SIT_EC022 ADD Crestline-GL in USI KONA BOM
 WK_SIT_EC023 Additional insulation sheet.
 WK_SIT_EC024 To drop ISL88550A (Intersil) as U7 alternate component because it has some issues

V3.04 (2007/02/13)

WK_SIT_EC025 1 To modify title Page.
 WK_SIT_EC026 To drop RJK)#!^DSP from all bom at SIT phase.
 WK_SIT_EC027 F3 change to 0 ohm 0603,F7 change to 0 ohm 1206
 WK_SIT_EC029 U61 Toshiba Rinkan version change to 1.5.
 WK_SIT_EC030 D103,D104 change to NO_ASM,U12 use TS3L500ERHUR or PI13L500A.

DESIGNER	J.CHEN	
CHECKED	Ogawa & OKU	
APPROVED	CHUJO	
CLASS	CHUJO	Part No . XXXXXX
THIS DOCUMENT IS THE PROPERTY OF LENOVO. ITS USE IS AUTHORIZED ONLY FOR RESPONDING TO A REQUEST FOR QUOTATION OR FOR THE PERFORMANCE OF WORK FOR LENOVO. ALL QUESTIONS MUST BE REFERRED TO THE LENOVO PURCHASING DEPARTMENT.		EC No . XXXXXX
		TITLE: Waikiki_1.1 Ver. V3.04
		EC History 2
LENOVO CONFIDENTIAL		sheet 100 of 100 Wednesday, February 14, 2007