

Compal Confidential

QAL51 MB Schematic Document

LA-7871P

Intel Ivy Bridge / Panther Point

Discrete : N13P-GS / N13P-GT

Rev: 1.0

2012.02.29

Security Classification	Compal Secret Data			Compal Electronics, Inc.			
Issued Date	2009/12/01	Deciphered Date	2012/12/31	Title	Cover Sheet		
<small>THIS SHEET OF ENGINEERING DRAWING IS THE PROPRIETARY PROPERTY OF COMPAL ELECTRONICS, INC. AND CONTAINS CONFIDENTIAL AND TRADE SECRET INFORMATION. THIS SHEET MAY NOT BE TRANSFERRED FROM THE CUSTODY OF THE COMPETENT DIVISION OF R&D DEPARTMENT EXCEPT AS AUTHORIZED BY COMPAL ELECTRONICS, INC. NEITHER THIS SHEET NOR THE INFORMATION IT CONTAINS MAY BE USED BY OR DISCLOSED TO ANY THIRD PARTY WITHOUT PRIOR WRITTEN CONSENT OF COMPAL ELECTRONICS, INC.</small>				Size	Document Number	Rev	
				Custom	QAL51, LA-7871P MB	1.0	
				Date:	Wednesday, March 07, 2012	Sheet 1 of 60	

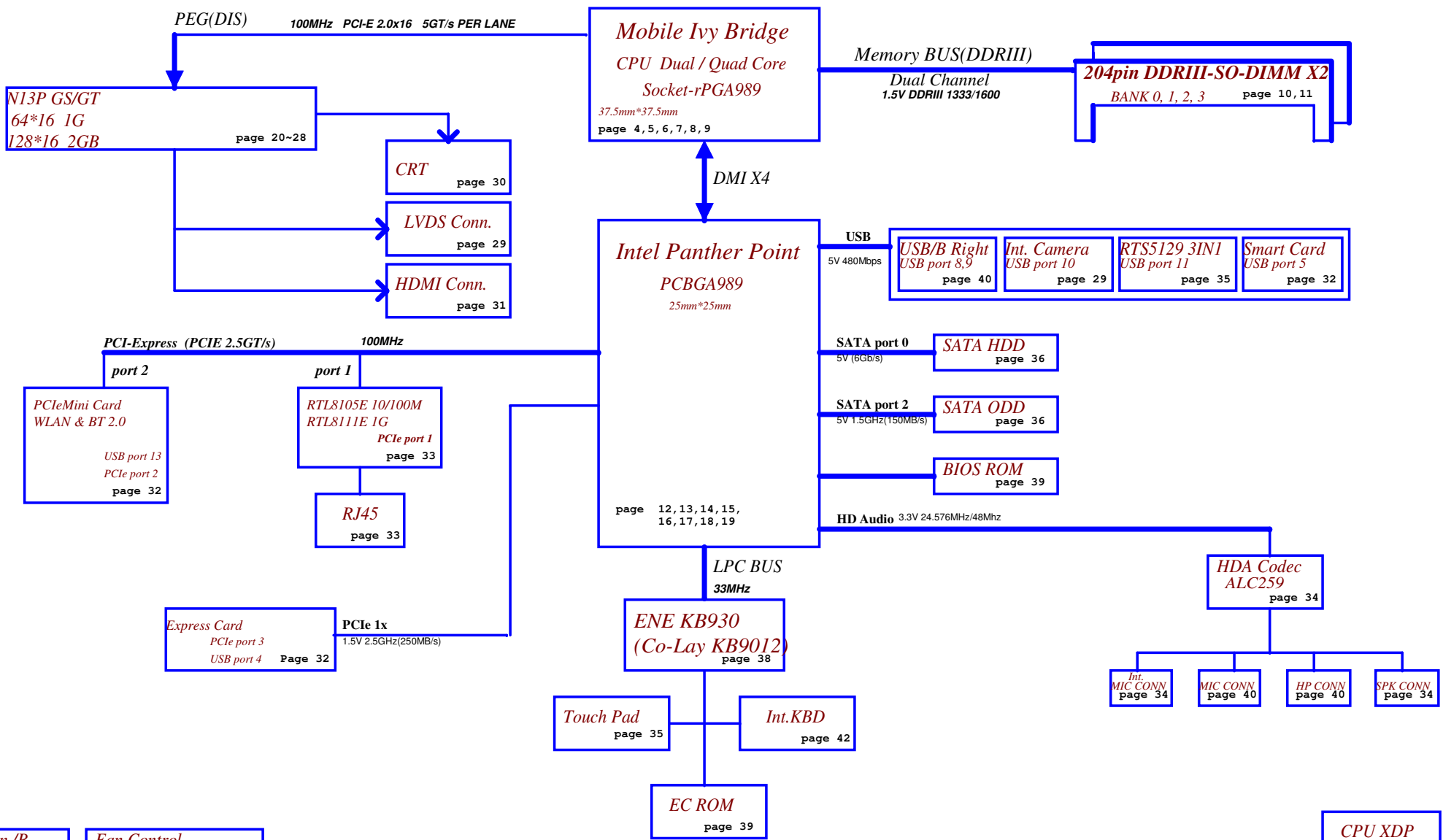

Function /B page 40	Fan Control page 41
USB&Audio/B page 40	RTC CKT. page 12
Power/B page 41	DC/DC Interface CKT. page 44
Touch Pad/B page 35	Power Circuit DC/DC page 45~56

CPU XDP page 5
PCH XDP page 12

Security Classification	Compal Secret Data			Title		
Issued Date	2011/05/23	Deciphered Date	2012/12/31	Compal Electronics, Inc.		
THIS SHEET OF ENGINEERING DRAWING IS THE PROPRIETARY PROPERTY OF COMPAL ELECTRONICS, INC. AND CONTAINS CONFIDENTIAL AND TRADE SECRET INFORMATION. THIS SHEET MAY NOT BE TRANSFERRED FROM THE CUSTODY OF THE COMPETENT DIVISION OF R&D DEPARTMENT EXCEPT AS AUTHORIZED BY COMPAL ELECTRONICS, INC. NEITHER THIS SHEET NOR THE INFORMATION IT CONTAINS MAY BE USED BY OR DISCLOSED TO ANY THIRD PARTY WITHOUT PRIOR WRITTEN CONSENT OF COMPAL ELECTRONICS, INC.				Chief River-Block Diagram Size B Document Number LA-7871P Rev 1.0 Date: Wednesday, March 07, 2012 Sheet 2 of 60		

Board ID Table for AD channel

Vcc	3.3V +/- 5%			
Ra	100K +/- 5%			
Board ID	Rb	V _{AD_BID min}	V _{AD_BID typ}	V _{AD_BID max}
0	0	0 V	0 V	0 V
1	8.2K +/- 5%	0.168V	0.250 V	0.362 V
2	18K +/- 5%	0.436 V	0.503 V	0.538 V
3	33K +/- 5%	0.712 V	0.819 V	0.875 V
4	56K +/- 5%	1.036 V	1.185 V	1.264 V
5	100K +/- 5%	1.453 V	1.650 V	1.759 V
6	200K +/- 5%	1.935 V	2.200 V	2.341 V
7	NC	2.500 V	3.300 V	3.300 V

BOARD ID Table

Board ID	PCB Revision
0	QAL30
1	QAL31 / LP
2	QAL31 / GT
3	
4	QAL50
5	QAL51 / GS
6	
7	QAL51 / GT

PCH	USB PORT#	DESTINATION
	0	USB2/3 (Left Hand side front)
	1	USB2/3 (Left Hand side back)
	2	None
	3	None
	4	USB2 (Right Hand side front)
	5	Smart CARD
	6	None
	7	None
	8	EXPRESS CARD
	9	USB2 (Right Hand side back)
	10	CAMERA
	11	Card Reader
	12	Finger Print
13	BT Comb	

SMBUS Control Table

	SOURCE	MIINI1	BATT 0001 011x b	SODIMM 1001 000x b	SODIMM 1001 010x b	VGA Int. Thermal 0x9A	JXDP1 JXDP2
EC_SMB_CK1 EC_SMB_DA1	KB930 KB9012	X	V	X	X	X	X
EC_SMB_CK2 EC_SMB_DA2	KB930 KB9012	X	X	X	X	V	X
PCH_SMBCLK PCH_SMBDATA	PCH	V	X	V	V	X	V
PCH_SMLCLK PCH_SMLDATA	PCH	X	X	X	X	V	X

CLKOUT	DESTINATION
PCI0	PCH_LOOPBACK
PCI1	EC
PCI2	TPM
PCI3	None
PCI4	None

OPTIMUS: XDP@/D@

CLK	DIFFERENTIAL	DESTINATION	FLEX CLOCKS	DESTINATION
	CLKOUT_PCIE0	LAN	CLKOUTFLEX0	None
	CLKOUT_PCIE1	WLAN	CLKOUTFLEX1	None
	CLKOUT_PCIE2	Express Card	CLKOUTFLEX2	None
	CLKOUT_PCIE3	None	CLKOUTFLEX3	None
	CLKOUT_PCIE4	None		
	CLKOUT_PCIE5	None		
	CLKOUT_PCIE6	None		
	CLKOUT_PCIE7	None		
	CLKOUT_PEG_A	VGA		
CLKOUT_PEG_B	None			

Symbol Note :

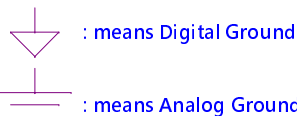

SATA	DESTINATION
SATA0	HDD
SATA1	None
SATA2	ODD
SATA3	None
SATA4	None
SATA5	None

PCI EXPRESS	DESTINATION
Lane 1	LAN
Lane 2	WLAN
Lane 3	Express Card
Lane 4	None
Lane 5	None
Lane 6	None
Lane 7	None
Lane 8	None

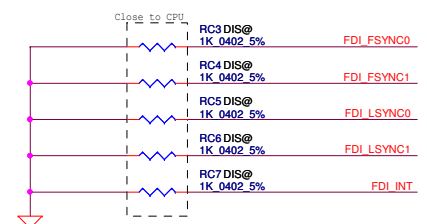
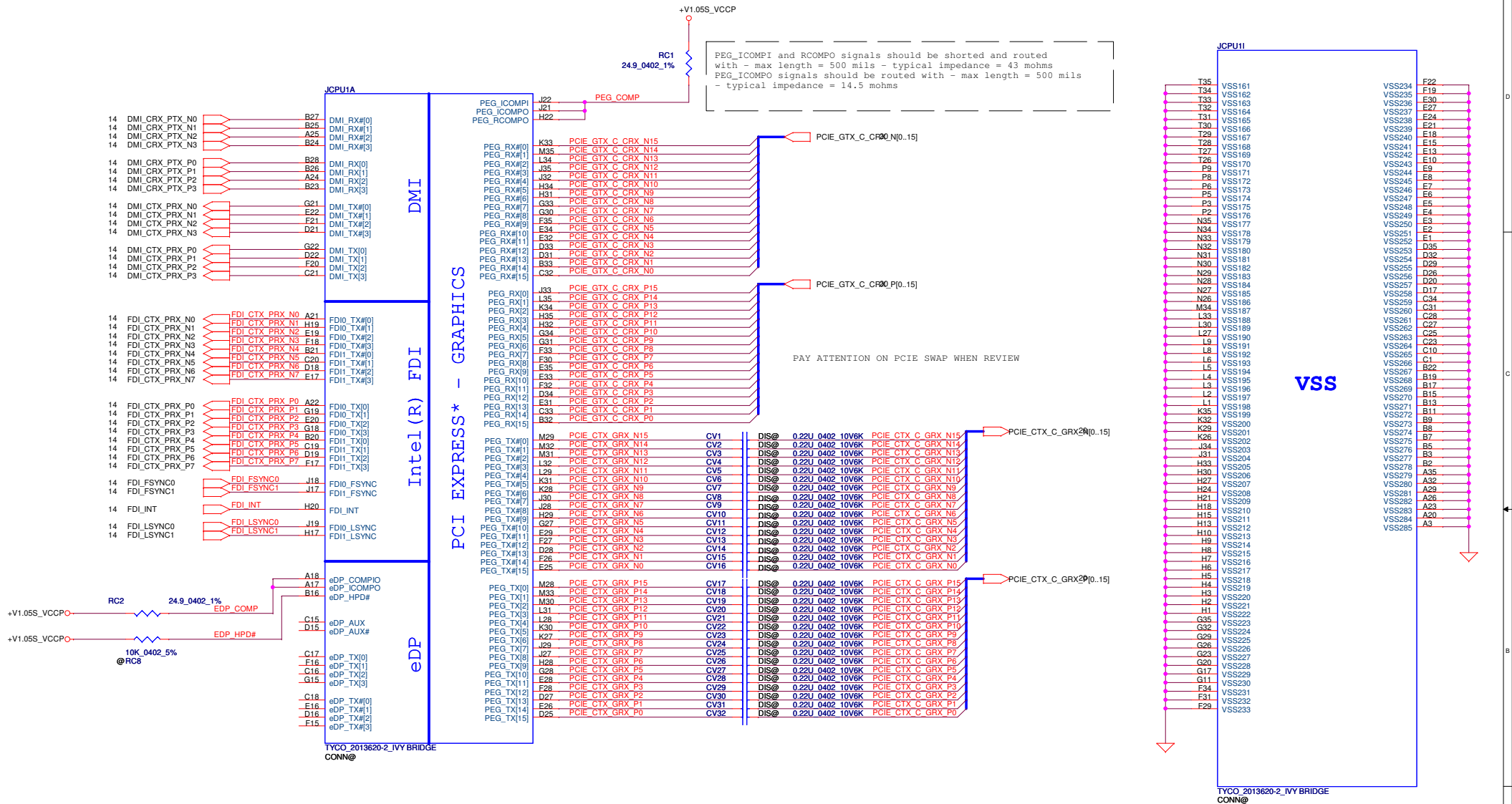

Security Classification	Compal Secret Data	
Issued Date	2011/05/23	Deciphered Date
		2012/12/31

THIS SHEET OF ENGINEERING DRAWING IS THE PROPRIETARY PROPERTY OF COMPAL ELECTRONICS, INC. AND CONTAINS CONFIDENTIAL AND TRADE SECRET INFORMATION. THIS SHEET MAY NOT BE TRANSFERRED FROM THE CUSTODY OF THE COMPETENT DIVISION OF R&D DEPARTMENT EXCEPT AS AUTHORIZED BY COMPAL ELECTRONICS, INC. NEITHER THIS SHEET NOR THE INFORMATION IT CONTAINS MAY BE USED BY OR DISCLOSED TO ANY THIRD PARTY WITHOUT PRIOR WRITTEN CONSENT OF COMPAL ELECTRONICS, INC.

Compal Electronics, Inc.		
PROCESSOR(I/6) DMI,FDI,PEG		
Title	Document Number	Rev
	QAL51, LA-7871P MB	1.0
Date:	Wednesday, March 07, 2012	Sheet 4 of 60

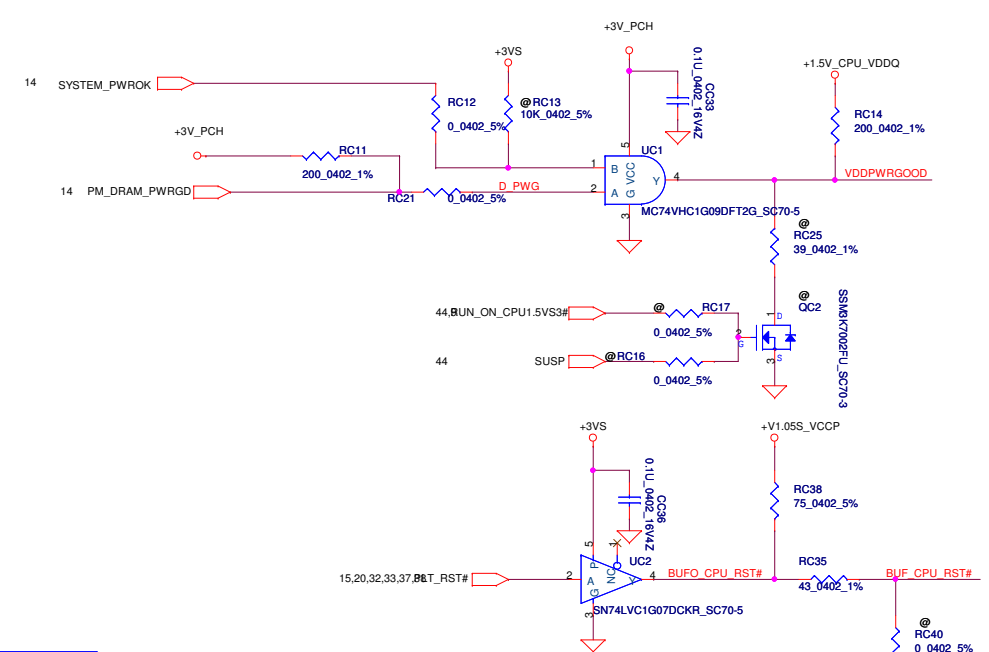
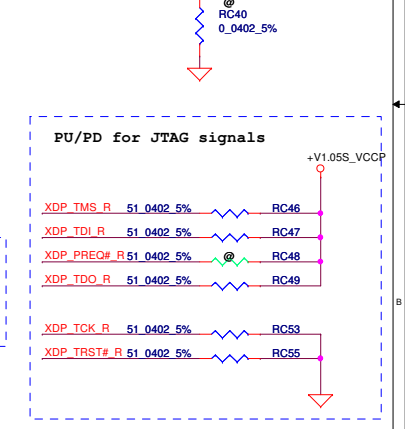
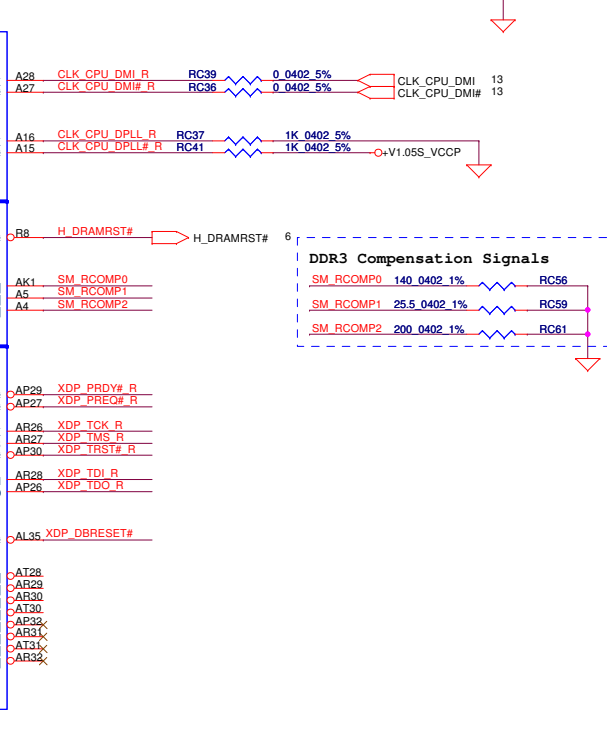
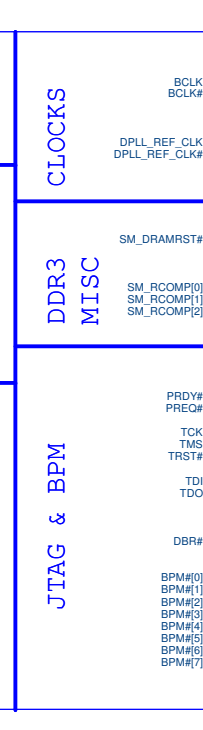
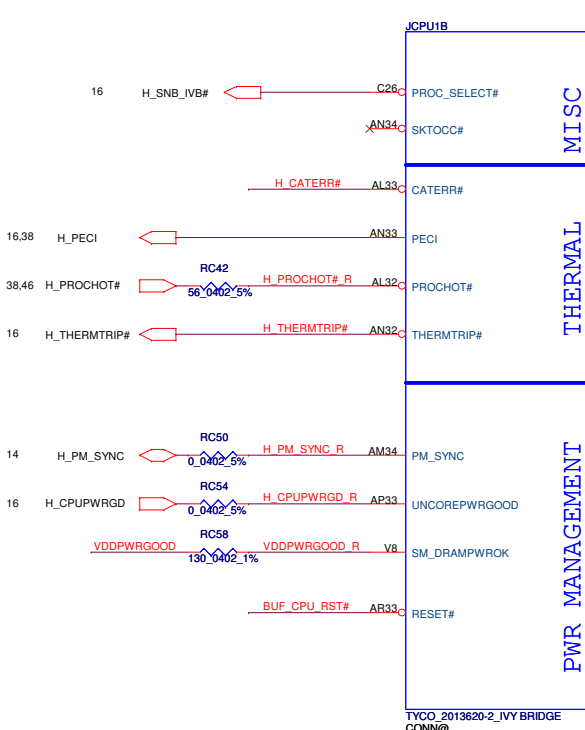
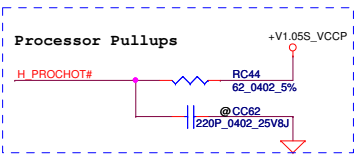

TYCO_20113620-2_IVY BRIDGE CONN@

Security Classification	Compal Secret Data	
Issued Date	2011/05/23	Deciphered Date
		2012/12/31

THIS SHEET OF ENGINEERING DRAWING IS THE PROPRIETARY PROPERTY OF COMPAL ELECTRONICS, INC. AND CONTAINS CONFIDENTIAL AND TRADE SECRET INFORMATION. THIS SHEET MAY NOT BE TRANSFERRED FROM THE CUSTODY OF THE COMPETENT DIVISION OF R&D DEPARTMENT EXCEPT AS AUTHORIZED BY COMPAL ELECTRONICS, INC. NEITHER THIS SHEET NOR THE INFORMATION IT CONTAINS MAY BE USED BY OR DISCLOSED TO ANY THIRD PARTY WITHOUT PRIOR WRITTEN CONSENT OF COMPAL ELECTRONICS, INC.

Compal Electronics, Inc.		
PROCESSOR(2/6) PM,XDP,CLK		
Size	Document Number	Rev
Custom	QAL51, LA-7871P MB	1.0
Date:	Wednesday, March 07, 2012	Sheet 5 of 60

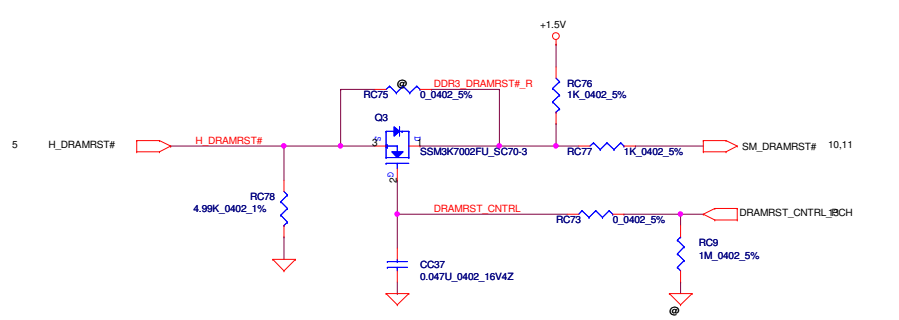
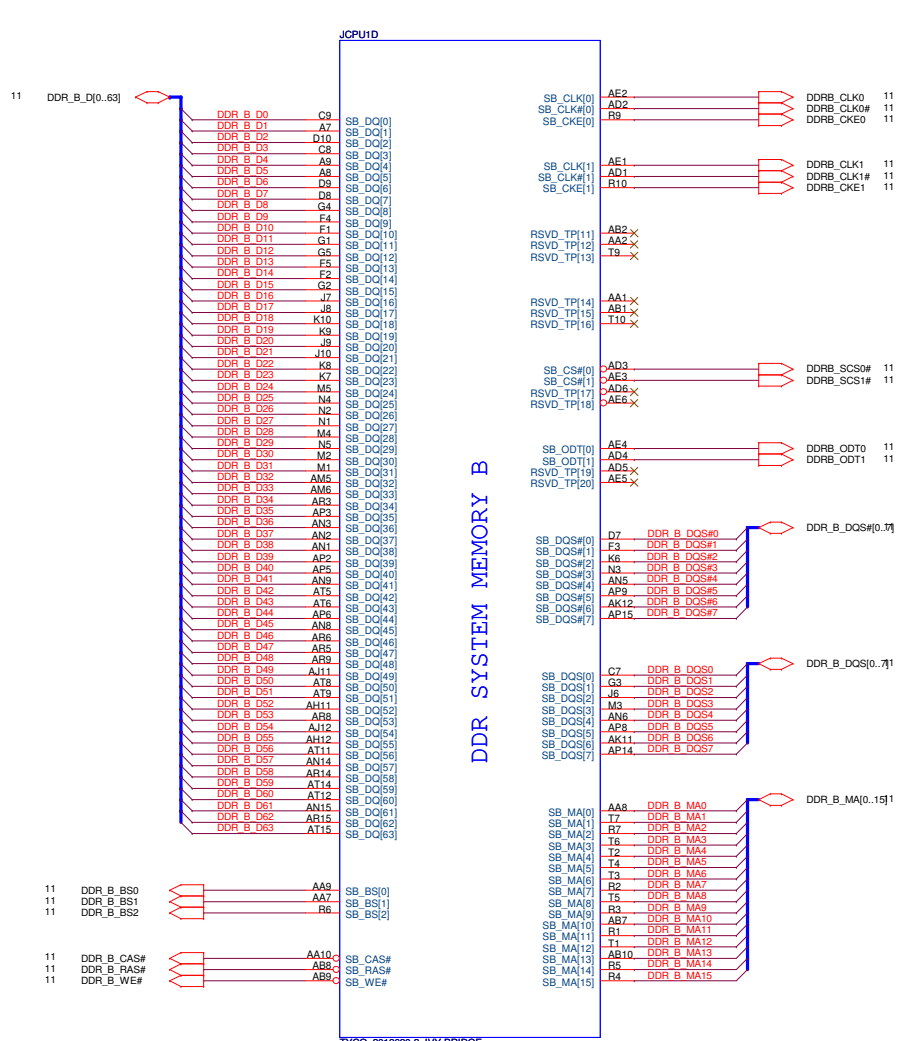
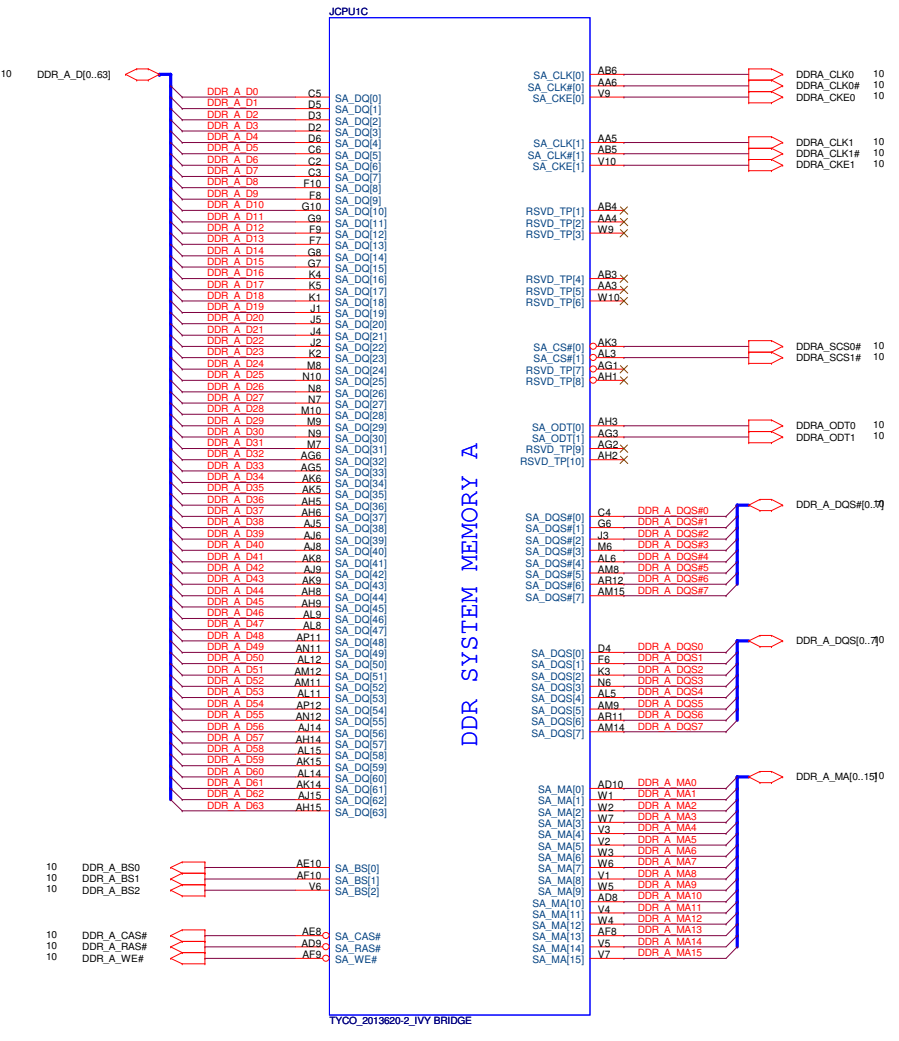

Security Classification	Compal Secret Data	
Issued Date	2011/05/23	Deciphered Date
		2012/12/31
THIS SHEET OF ENGINEERING DRAWING IS THE PROPRIETARY PROPERTY OF COMPAL ELECTRONICS, INC. AND CONTAINS CONFIDENTIAL AND TRADE SECRET INFORMATION. THIS SHEET MAY NOT BE TRANSFERRED FROM THE CUSTODY OF THE COMPETENT DIVISION OF R&D DEPARTMENT EXCEPT AS AUTHORIZED BY COMPAL ELECTRONICS, INC. NEITHER THIS SHEET NOR THE INFORMATION IT CONTAINS MAY BE USED BY OR DISCLOSED TO ANY THIRD PARTY WITHOUT PRIOR WRITTEN CONSENT OF COMPAL ELECTRONICS, INC.		

Compal Electronics, Inc.	
Title	PROCESSOR(3/6) DDRIII
Size	Document Number
Custom	QAL51_LA-7871P MB
Date	Wednesday, March 07, 2012
Sheet	6 of 60
Rev	1.0

CFG Straps for Processor

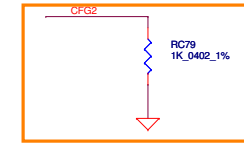
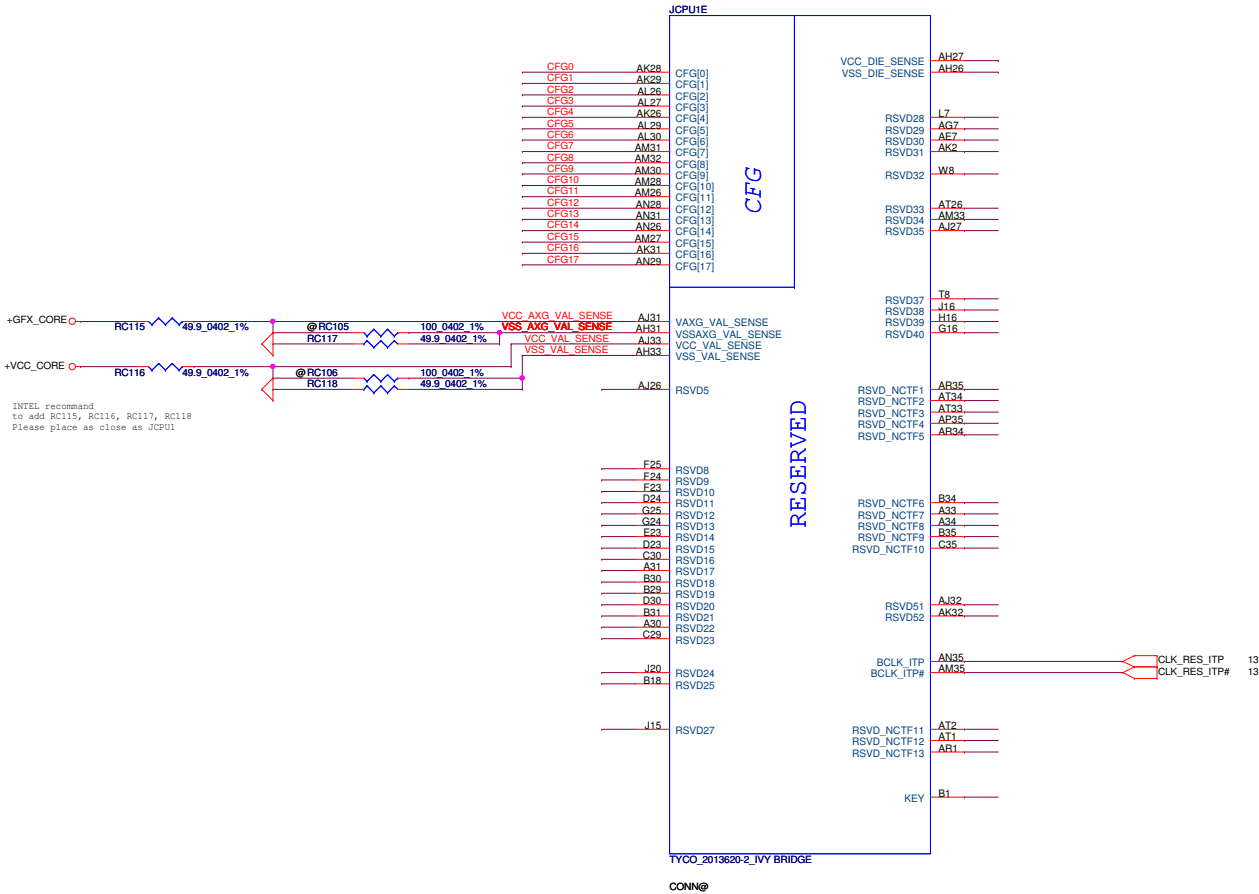

PEG Static Lane Reversal - CFG2 is for the 16x	
CFG2	1: (Default) Normal Operation; Lane # definition matches socket pin map definition 0: Lane Reversed

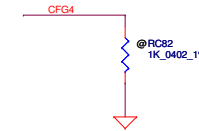

Display Port Presence Strap	
CFG4	1 : Disabled; No Physical Display Port attached to Embedded Display Port 0 : Enabled; An external Display Port device is connected to the Embedded Display Port

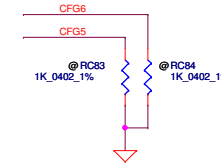

PCIe Port Bifurcation Straps	
CFG[6:5]	11: (Default) x16 - Device 1 functions 1 and 2 disabled 10: x8, x8 - Device 1 function 1 enabled ; function 2 disabled 01: Reserved - (Device 1 function 1 disabled ; function 2 enabled) 00: x8,x4,x4 - Device 1 functions 1 and 2 enabled

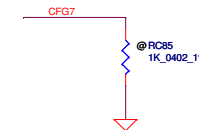

PEG DEFER TRAINING	
CFG7	1: (Default) PEG Train immediately following RESETB de assertion 0: PEG Wait for BIOS for training

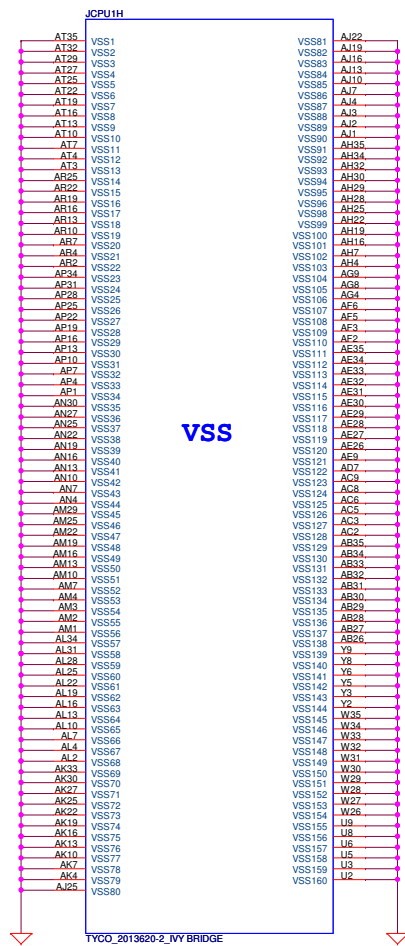

POWER

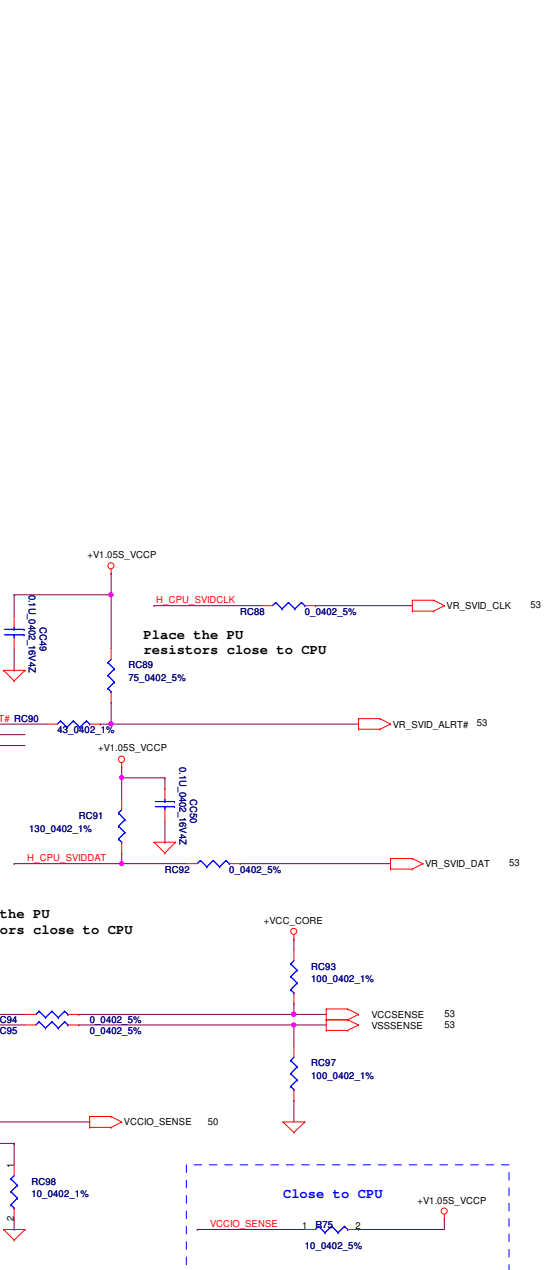
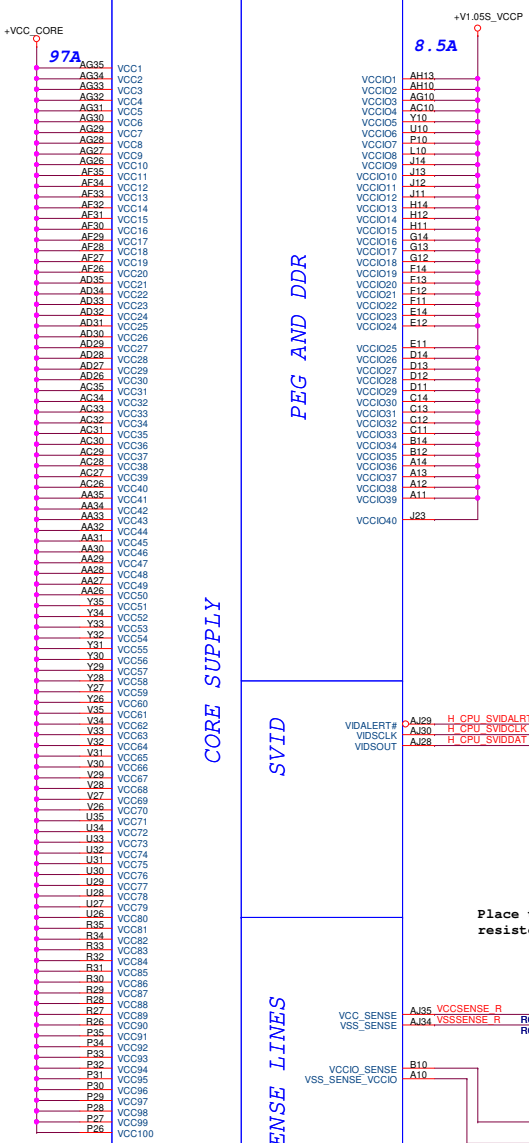

Security Classification	Compal Secret Data	
Issued Date	2011/05/23	Deciphered Date 2012/12/31
THIS SHEET OF ENGINEERING DRAWING IS THE PROPRIETARY PROPERTY OF COMPAL ELECTRONICS, INC. AND CONTAINS CONFIDENTIAL AND TRADE SECRET INFORMATION. THIS SHEET MAY NOT BE TRANSFERRED FROM THE CUSTODY OF THE COMPETENT DIVISION OF R&D DEPARTMENT EXCEPT AS AUTHORIZED BY COMPAL ELECTRONICS, INC. NEITHER THIS SHEET NOR THE INFORMATION IT CONTAINS MAY BE USED BY OR DISCLOSED TO ANY THIRD PARTY WITHOUT PRIOR WRITTEN CONSENT OF COMPAL ELECTRONICS, INC.		

Compal Electronics, Inc.	
Title	PROCESSOR(5/6) PWR,BYPASS
Document Number	QAL51_LA-7871P_MB
Size	Customer
Date	Wednesday, March 07, 2012
Sheet	8 of 60
Rev	1.0

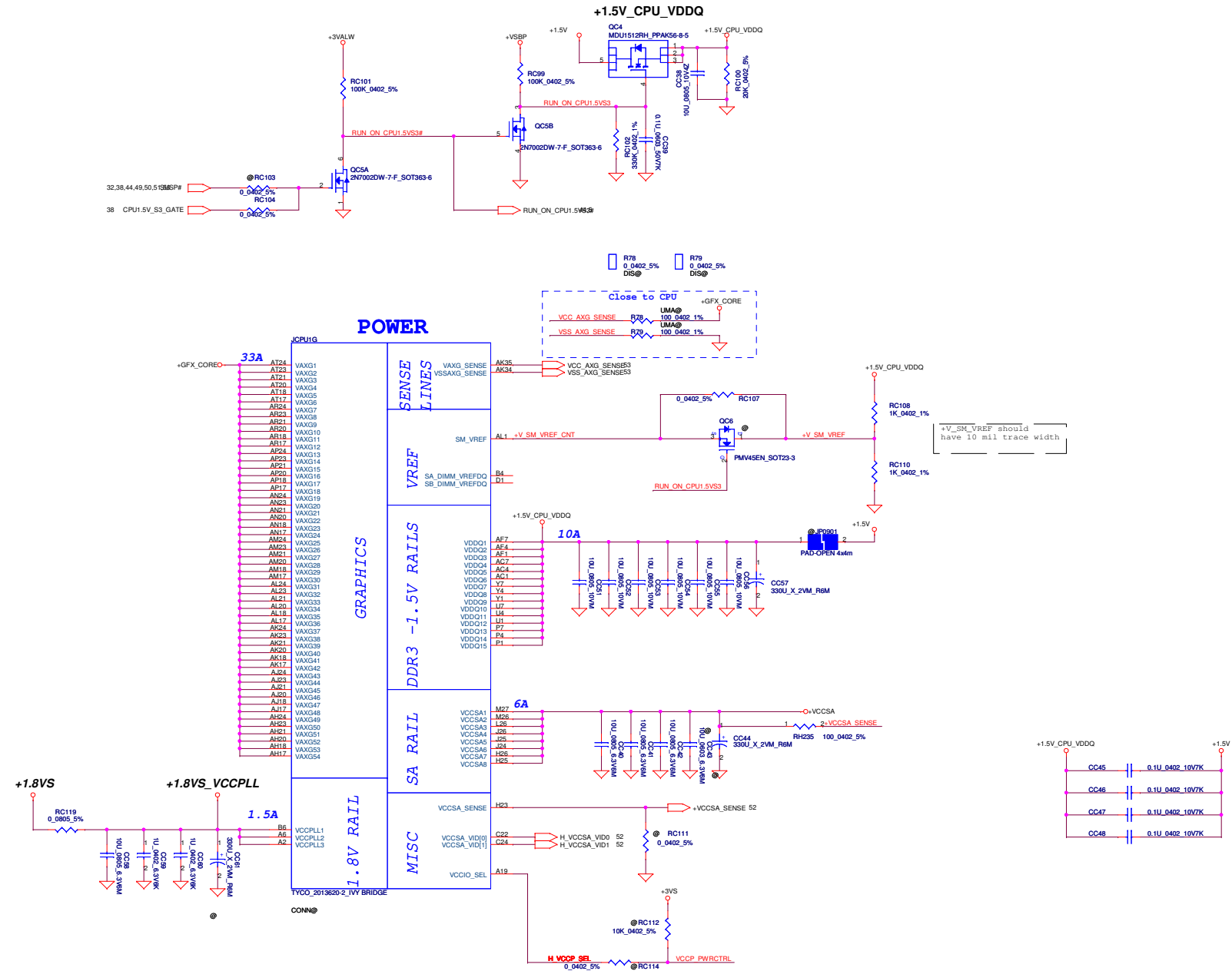

Ivy Bridge drives VCCIO_SEL low
 VCCP_PWRCTRL:0

Sandy Bridge is NC for A19
 VCCP_PWRCTRL:1

Security Classification		Compal Secret Data		Title	
Issued Date	2011/05/23	Deciphered Date	2012/12/31	PROCESOR(6/6) PWR,VSS	
THIS SHEET OF ENGINEERING DRAWING IS THE PROPRIETARY PROPERTY OF COMPAL ELECTRONICS, INC. AND CONTAINS CONFIDENTIAL AND TRADE SECRET INFORMATION. THIS SHEET MAY NOT BE TRANSFERRED FROM THE CUSTODY OF THE COMPETENT DIVISION OF R&D DEPARTMENT EXCEPT AS AUTHORIZED BY COMPAL ELECTRONICS, INC. NEITHER THIS SHEET NOR THE INFORMATION IT CONTAINS MAY BE USED BY OR DISCLOSED TO ANY THIRD PARTY WITHOUT PRIOR WRITTEN CONSENT OF COMPAL ELECTRONICS, INC.				Size	Document Number
				QAL51_LA-7871P MB	Rev
				1.0	
Date:	Wednesday, March 07, 2012	Sheet	9	of 60	

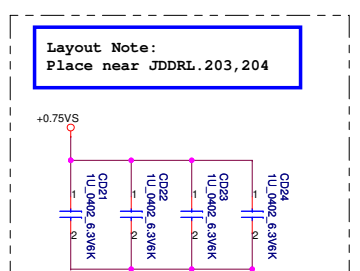
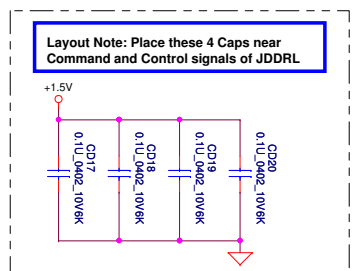
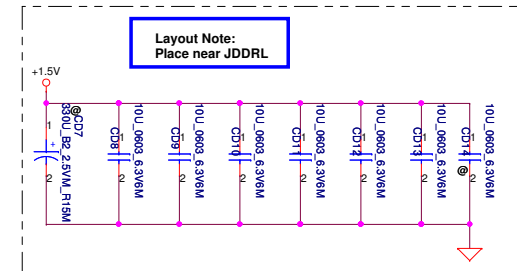
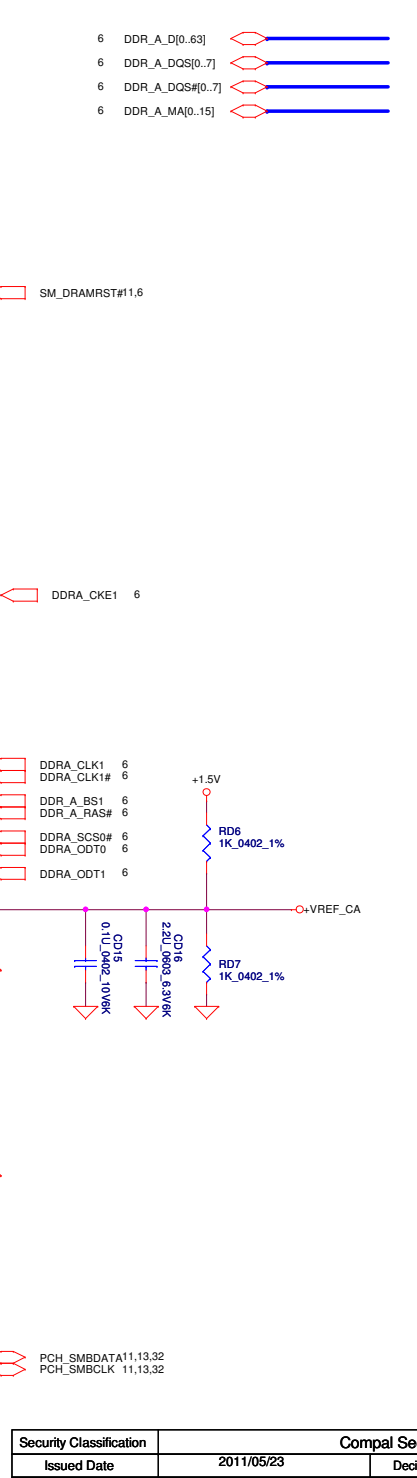
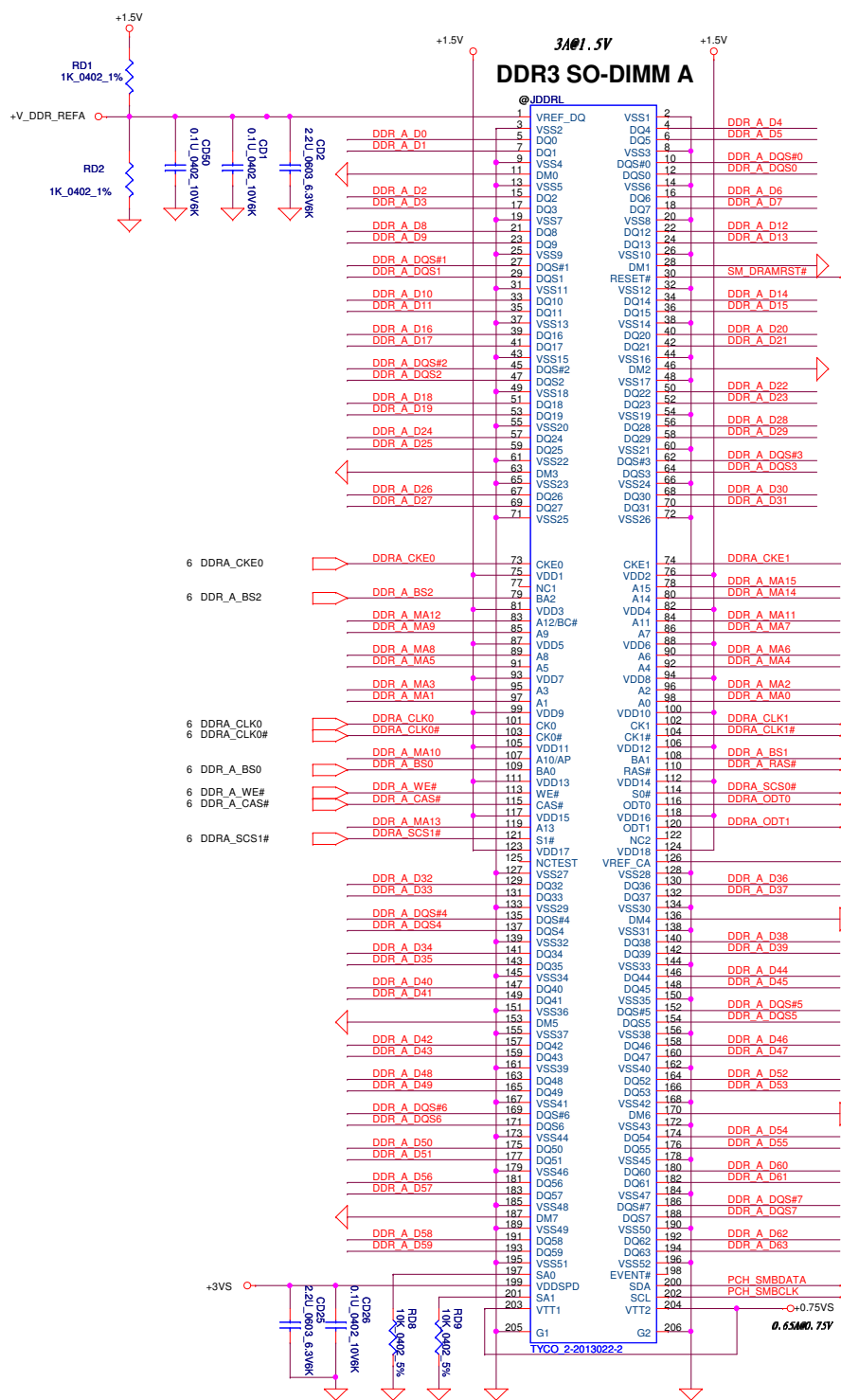

Security Classification	Compal Secret Data	
Issued Date	2011/05/23	Deciphered Date
		2012/12/31

THIS SHEET OF ENGINEERING DRAWING IS THE PROPRIETARY PROPERTY OF COMPAL ELECTRONICS, INC. AND CONTAINS CONFIDENTIAL AND TRADE SECRET INFORMATION. THIS SHEET MAY NOT BE TRANSFERRED FROM THE CUSTODY OF THE COMPETENT DIVISION OF R&D DEPARTMENT EXCEPT AS AUTHORIZED BY COMPAL ELECTRONICS, INC. NEITHER THIS SHEET NOR THE INFORMATION IT CONTAINS MAY BE USED BY OR DISCLOSED TO ANY THIRD PARTY WITHOUT PRIOR WRITTEN CONSENT OF COMPAL ELECTRONICS, INC.

Compal Electronics, Inc.		
DDRIII-DDRL		
Title	Document Number	Rev
	QAL51, LA-7871P MB	1.0
Date:	Wednesday, March 07, 2012	Sheet 10 of 60

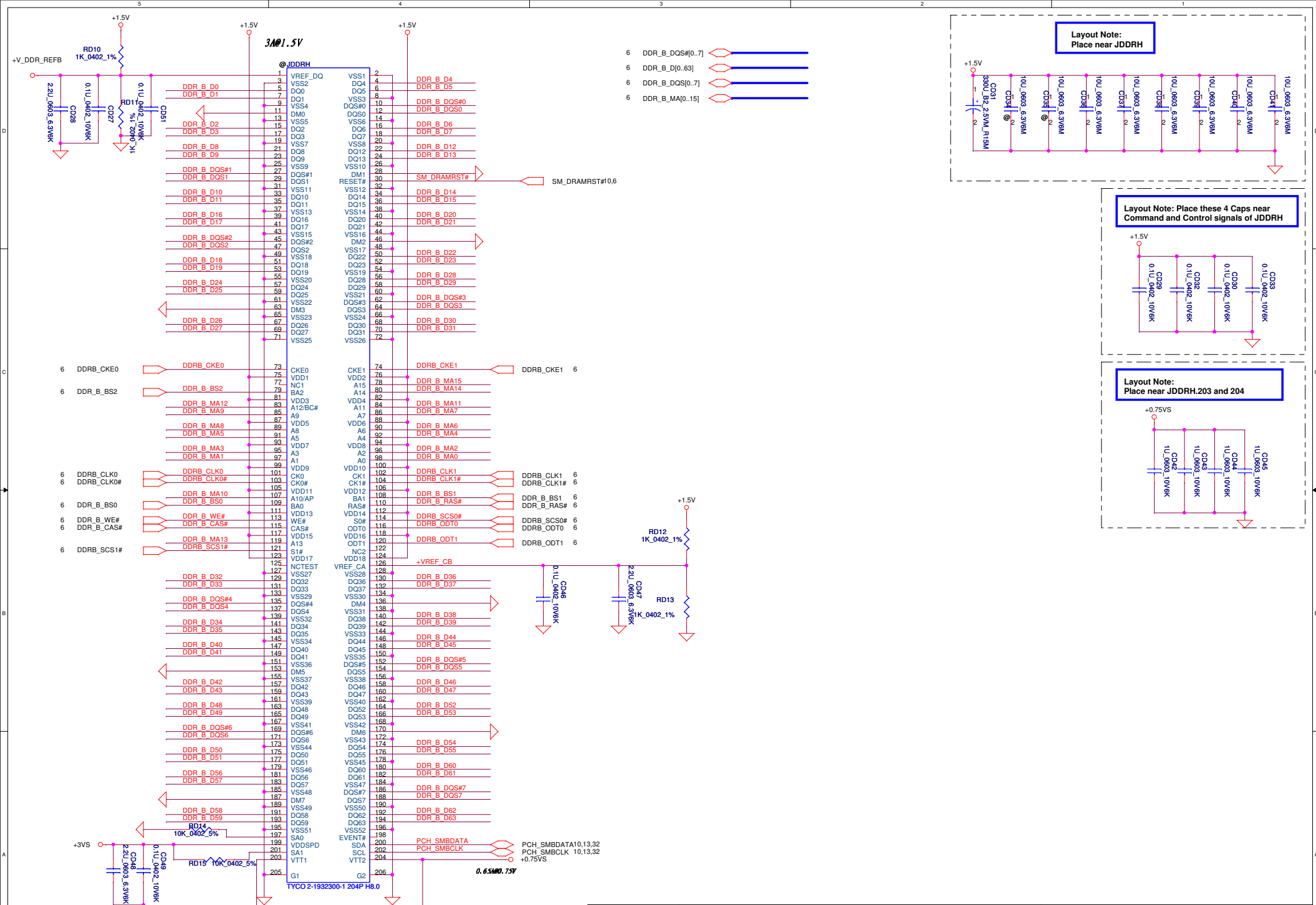

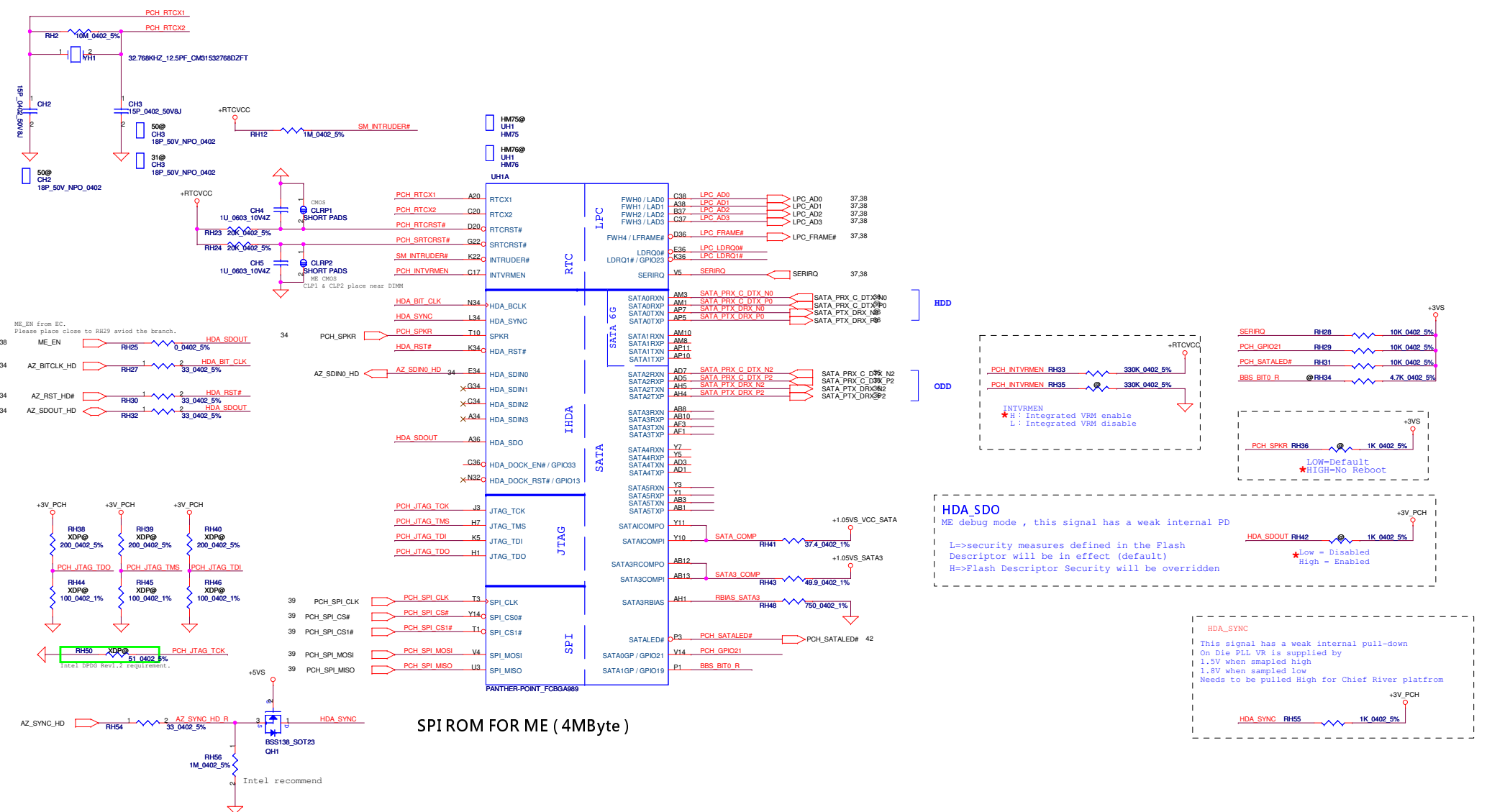

SPI ROM FOR ME (4MByte)

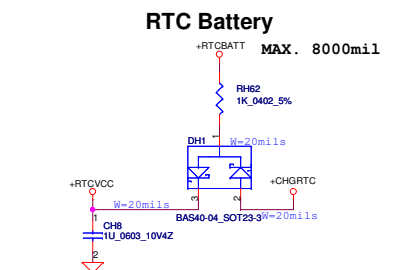
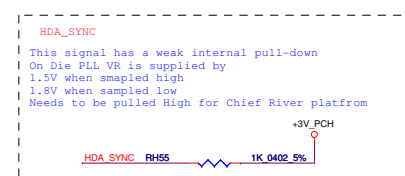
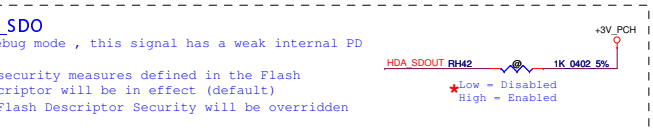
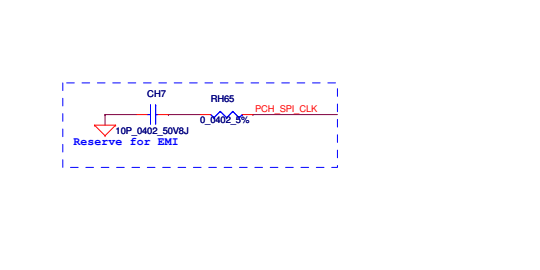

Security Classification	Compal Secret Data		Title	
Issued Date	2011/05/23	Deciphered Date	2012/12/31	Compal Electronics, Inc.
THIS SHEET OF ENGINEERING DRAWING IS THE PROPRIETARY PROPERTY OF COMPAL ELECTRONICS, INC. AND CONTAINS CONFIDENTIAL AND TRADE SECRET INFORMATION. THIS SHEET MAY NOT BE TRANSFERRED FROM THE CUSTODY OF THE COMPETENT DIVISION OF R&D DEPARTMENT EXCEPT AS AUTHORIZED BY COMPAL ELECTRONICS, INC. NEITHER THIS SHEET NOR THE INFORMATION IT CONTAINS MAY BE USED BY OR DISCLOSED TO ANY THIRD PARTY WITHOUT PRIOR WRITTEN CONSENT OF COMPAL ELECTRONICS, INC.				PCH (I/8) SATA, HDA, SPI, LPC QAL51, LA-7871P MB Rev 1.0
Date:	Wednesday, March 07 2012	Sheet	12	of 60

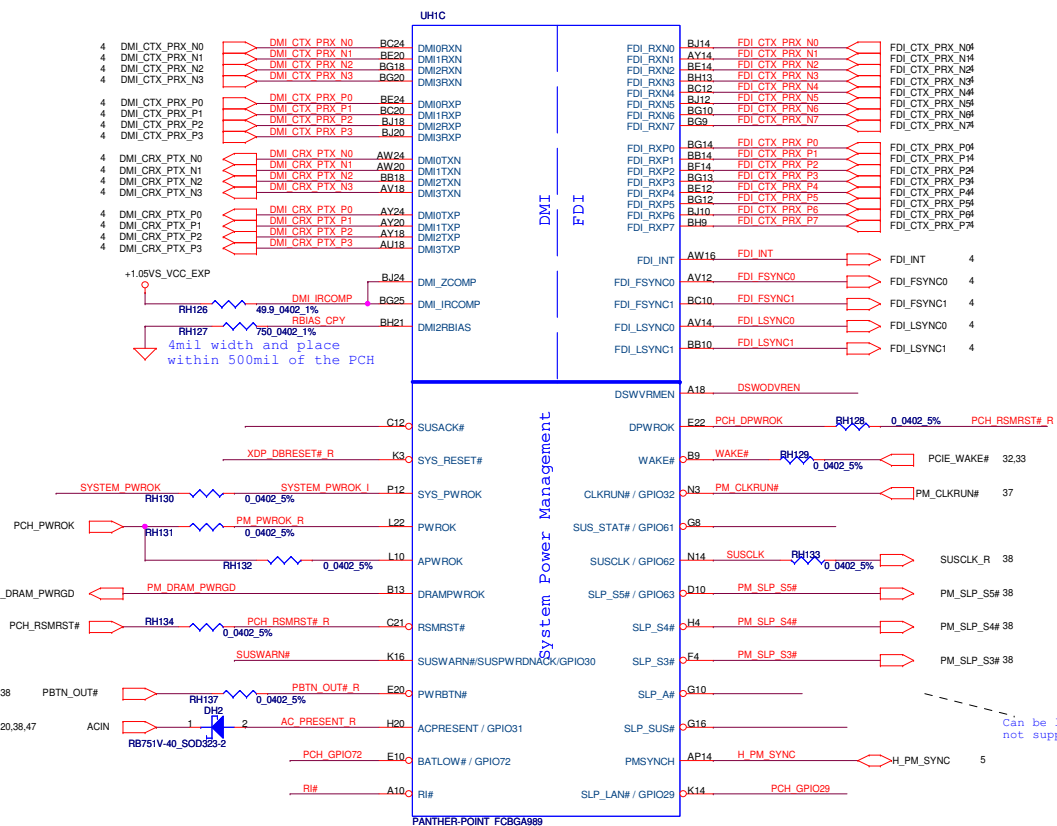

Pull high at LVDS conn side.

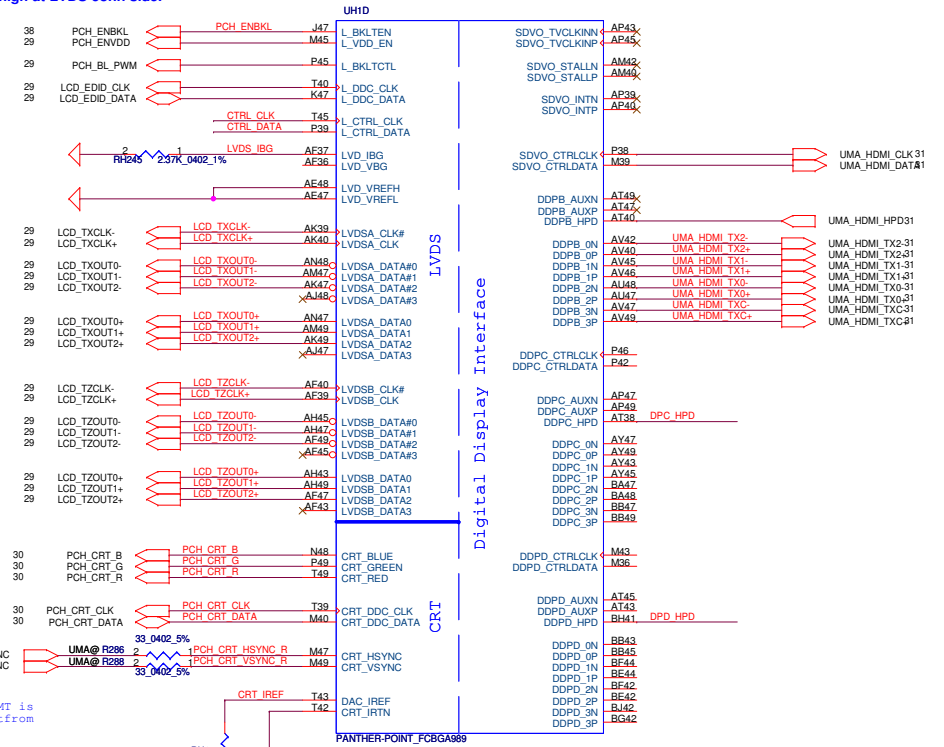

Can be left NC when IAMT is not support on the platform

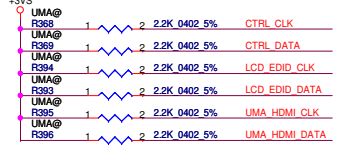
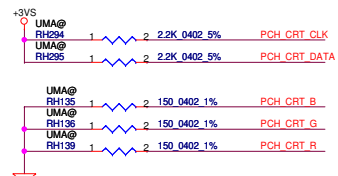
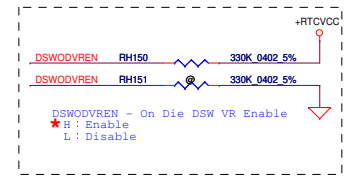
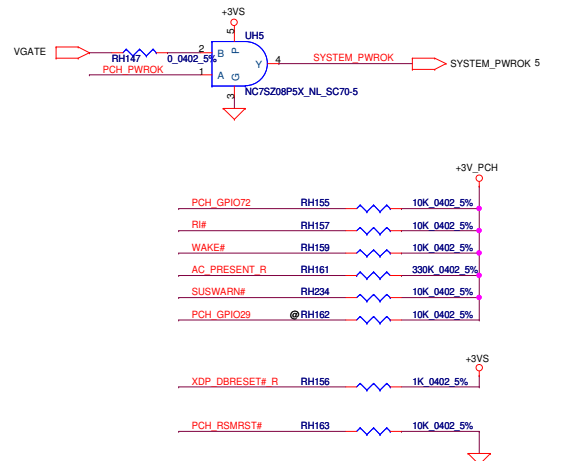

Security Classification		Compal Secret Data		Compal Electronics, Inc.	
Issued Date	2011/05/23	Deciphered Date	2012/12/31	Title	
				PCH (3/8) DMI,FDI,PM,GFX,DP	
THIS SHEET OF ENGINEERING DRAWING IS THE PROPRIETARY PROPERTY OF COMPAL ELECTRONICS, INC. AND CONTAINS CONFIDENTIAL AND TRADE SECRET INFORMATION. THIS SHEET MAY NOT BE TRANSFERRED FROM THE CUSTODY OF THE COMPETED DIVISION OF R&D DEPARTMENT EXCEPT AS AUTHORIZED BY COMPAL ELECTRONICS, INC. NEITHER THIS SHEET NOR THE INFORMATION IT CONTAINS MAY BE USED BY OR DISCLOSED TO ANY THIRD PARTY WITHOUT PRIOR WRITTEN CONSENT OF COMPAL ELECTRONICS, INC.		Date		Wednesday, March 07, 2012	
Date		Sheet		Rev	
		14		0	

USB3.0 Port0
Port 0 : Left USB3.0

USB3.0 Port1
Port 1 : Left USB3.0 with e-SATA

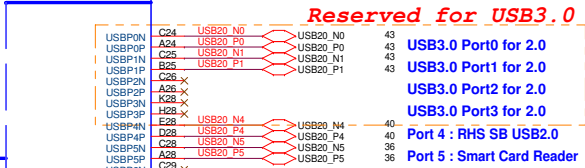
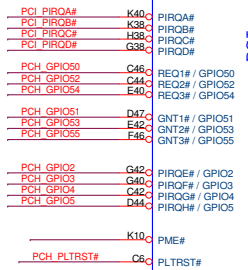
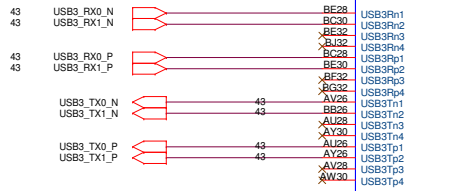

Reserved for USB3.0

- USB3.0 Port0 for 2.0
- USB3.0 Port1 for 2.0
- USB3.0 Port2 for 2.0
- USB3.0 Port3 for 2.0
- Port 4 : RHS SB USB2.0
- Port 5 : Smart Card Reader
- Port 8 : Express Card
- Port 9 : RHS SB USB2.0
- Port 10 : Int. Carema
- Port 11 : Card Reader
- Port 12 : Finger Print
- Port 13 : BT

GPIO19 => BBS_BIT0
GPIO51 => BBS_BIT1

Boot BIOS Strap		
BBS_BIT0	BBS_BIT1	Boot BIOS Location
0	0	LPC
0	1	Reserved (NAND)
1	0	Reserved
1	1	SPT *

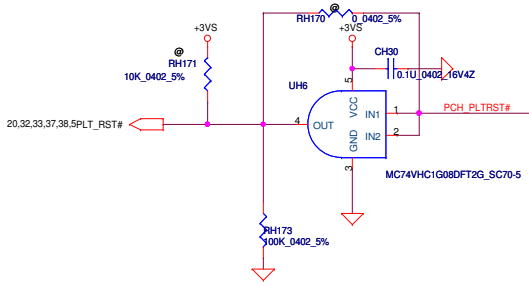
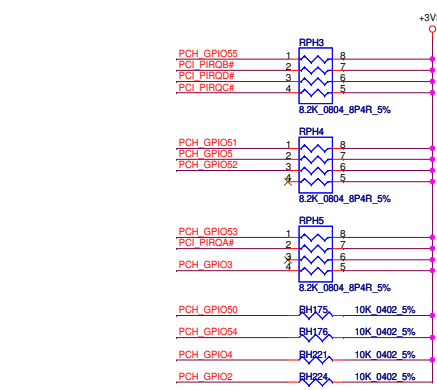
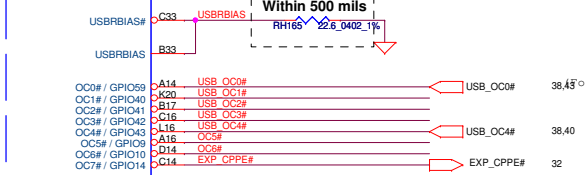
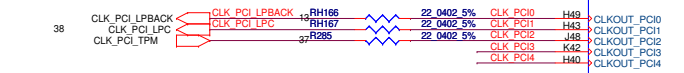
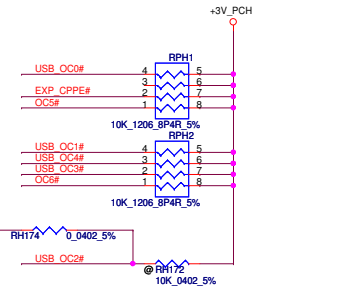
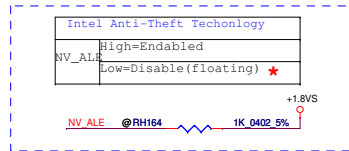

Security Classification	Compal Secret Data		Title Compal Electronics, Inc. PCH (4/8) PCI, USB, NVRAM
Issued Date	2011/05/23	Deciphered Date	
THIS SHEET OF ENGINEERING DRAWING IS THE PROPRIETARY PROPERTY OF COMPAL ELECTRONICS, INC. AND CONTAINS CONFIDENTIAL AND TRADE SECRET INFORMATION. THIS SHEET MAY NOT BE TRANSFERRED FROM THE CUSTODY OF THE COMPETENT DIVISION OF R&D DEPARTMENT EXCEPT AS AUTHORIZED BY COMPAL ELECTRONICS, INC. NEITHER THIS SHEET NOR THE INFORMATION IT CONTAINS MAY BE USED BY OR DISCLOSED TO ANY THIRD PARTY WITHOUT PRIOR WRITTEN CONSENT OF COMPAL ELECTRONICS, INC.			Size: Custom Document Number: QAL51_LA-7871P MB Date: Wednesday, March 07, 2012 Sheet: 15 of 60

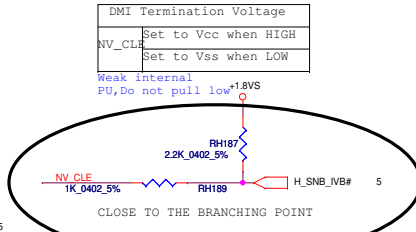
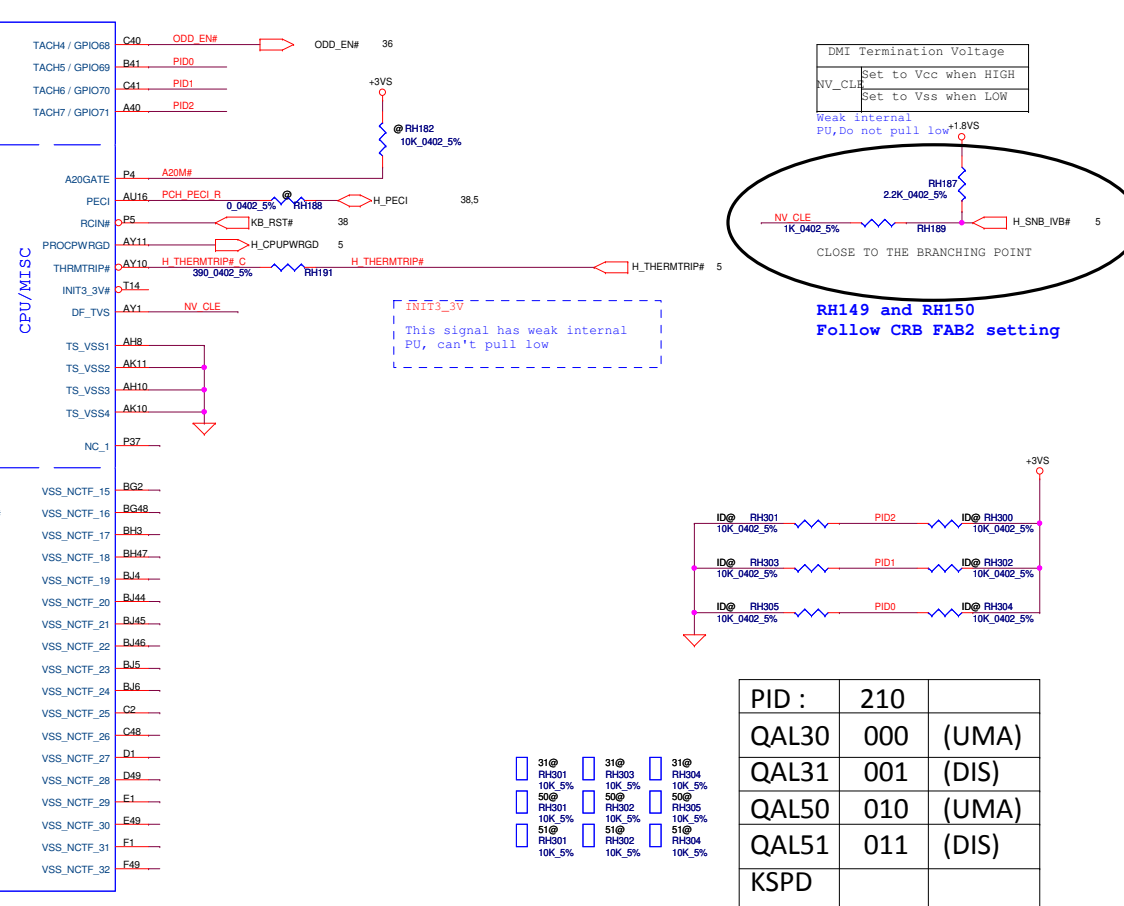
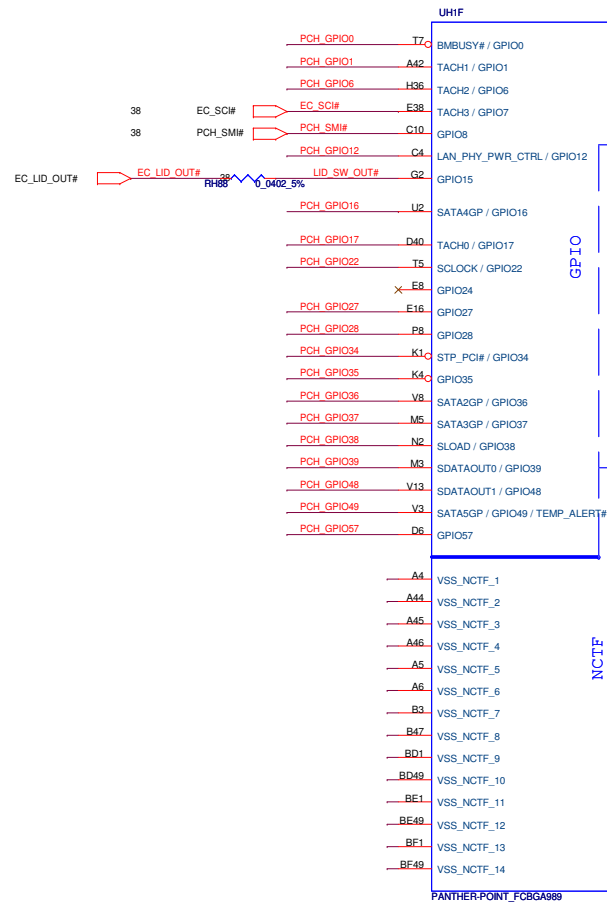
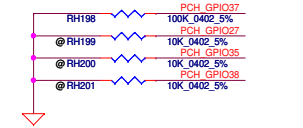
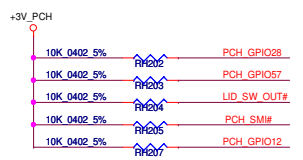
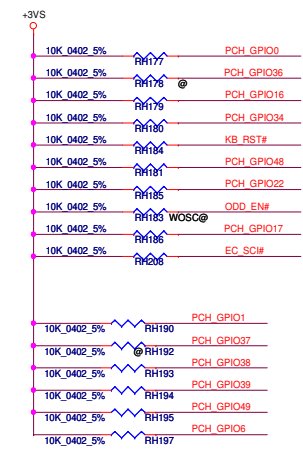

RH149 and RH150
Follow CRB FAB2 setting

INIT3_3V
This signal has weak internal PU, can't pull low

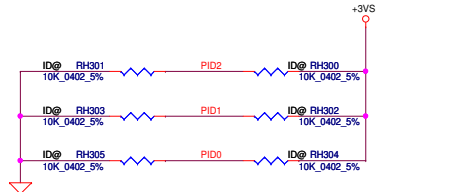

PID :	210	
QAL30	000	(UMA)
QAL31	001	(DIS)
QAL50	010	(UMA)
QAL51	011	(DIS)
KSPD		
Q0000	1XX	

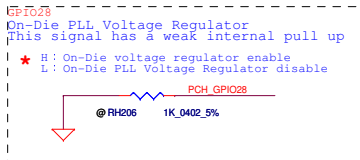

PCH_GPIO28 needs to be connected to XDP_FN8
PCH_GPIO35 needs to be connected to XDP_FN9
PCH_GPIO15 needs to be connected to XDP_FN16
Please refer to Huron River Debug Board DG 1.2

Security Classification	Compal Secret Data		Title Compal Electronics, Inc. PCH (5/8) GPIO, CPU, MISC
Issued Date	2011/05/23	Deciphered Date	
THIS SHEET OF ENGINEERING DRAWING IS THE PROPRIETARY PROPERTY OF COMPAL ELECTRONICS, INC. AND CONTAINS CONFIDENTIAL AND TRADE SECRET INFORMATION. THIS SHEET MAY NOT BE TRANSFERRED FROM THE CUSTODY OF THE COMPETENT DIVISION OF R&D DEPARTMENT EXCEPT AS AUTHORIZED BY COMPAL ELECTRONICS, INC. NEITHER THIS SHEET NOR THE INFORMATION IT CONTAINS MAY BE USED BY OR DISCLOSED TO ANY THIRD PARTY WITHOUT PRIOR WRITTEN CONSENT OF COMPAL ELECTRONICS, INC.			Size Custom
			Document Number QAL51, LA-7871P MB
			Rev 1.0
			Date: Wednesday, March 07, 2012
			Sheet 16 of 60

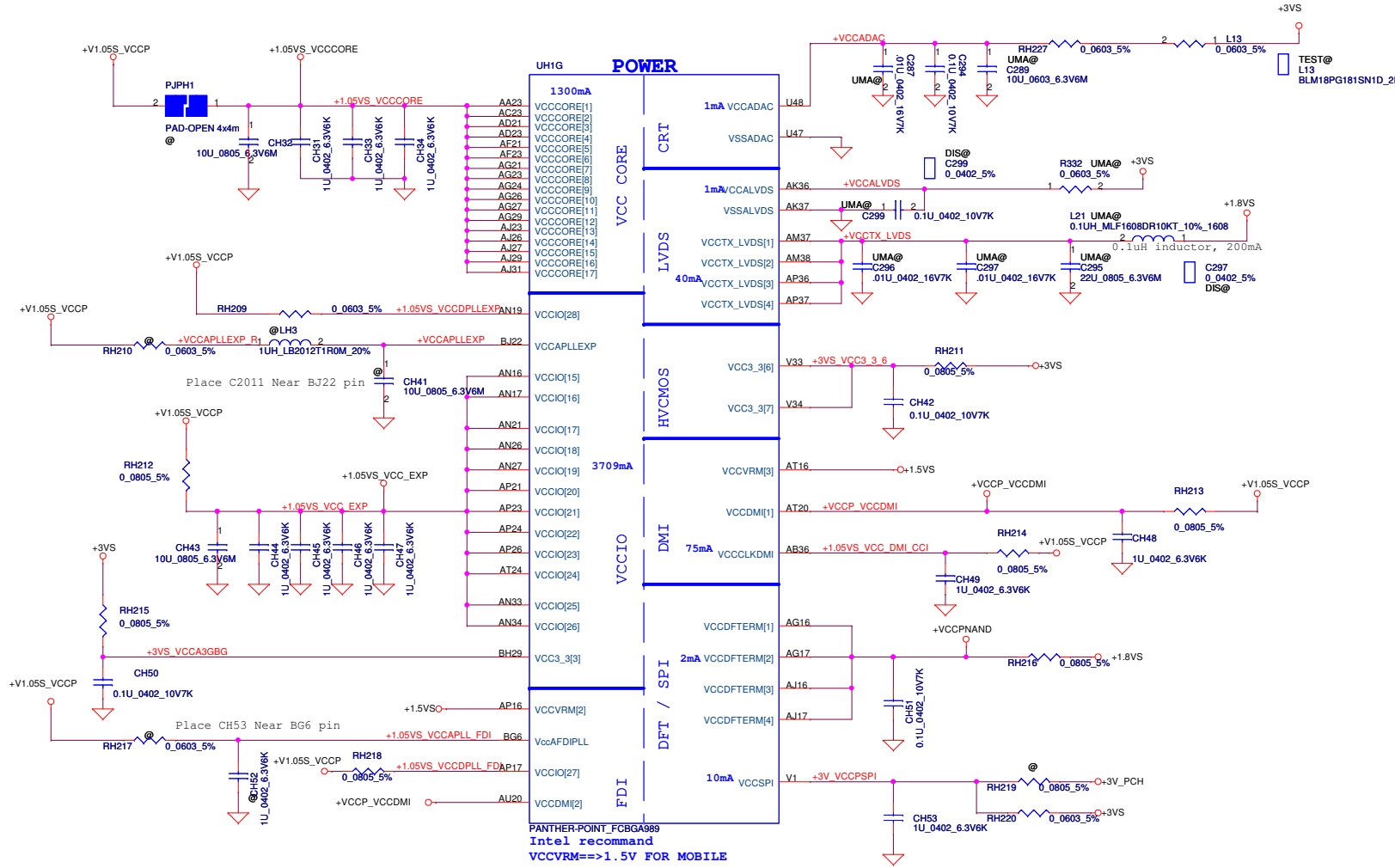

PCH Power Rail Table Refer to CPU EDS R1.5		
Voltage Rail	Voltage	SO Iccmax Current (A)
V_PROC_IO	1.05	0.001
V5REF	5	0.001
V5REF_Sus	5	0.001
Vcc3_3	3.3	0.228
VccADAC	3.3	0.001
VccADPLLA	1.05	0.075
VccADPLLB	1.05	0.075
VccCore	1.05	1.3
VccDMI	1.05	0.042
VccIO	1.05	3.709
VccASW	1.05	0.903
VccSPI	3.3	0.01
VccDSW	3.3	0.001
VccDFTERM	1.8	0.002
VccRTC	3.3	6 uA
VccSus3_3	3.3	0.065
VccSusHDA	3.3 / 1.5	0.01
VccVRM	1.8 / 1.5	0.167
VccCLKDMI	1.05	0.075
VccSSC	1.05	0.095
VccDIFFCLKN	1.05	0.055
VccALVDS	3.3	0.001
VccTX_LVDS	1.8	0.04

PANTHER-POINT_FCBGA989
Intel recommend
VCCVRM==>1.5V FOR MOBILE

Security Classification	Compal Secret Data	
Issued Date	2011/05/23	Deciphered Date
		2012/12/31
THIS SHEET OF ENGINEERING DRAWING IS THE PROPRIETARY PROPERTY OF COMPAL ELECTRONICS, INC. AND CONTAINS CONFIDENTIAL AND TRADE SECRET INFORMATION. THIS SHEET MAY NOT BE TRANSFERRED FROM THE CUSTODY OF THE COMPETENT DIVISION OF R&D DEPARTMENT EXCEPT AS AUTHORIZED BY COMPAL ELECTRONICS, INC. NEITHER THIS SHEET NOR THE INFORMATION IT CONTAINS MAY BE USED BY OR DISCLOSED TO ANY THIRD PARTY WITHOUT PRIOR WRITTEN CONSENT OF COMPAL ELECTRONICS, INC.		

Compal Electronics, Inc.		
Title	PCH (6/8) PWR	
Size	Document Number	Rev
Custom	QAL51, LA-7871P MB	1.0
Date:	Wednesday, March 07, 2012	Sheet 17 of 60

UH1H		
H5	VSS[0]	
AA17	VSS[1]	VSS[80] AK38
AA2	VSS[2]	VSS[81] AK4
AA3	VSS[3]	VSS[82] AK42
AA33	VSS[4]	VSS[83] AK46
AA34	VSS[5]	VSS[84] AK6
AB11	VSS[6]	VSS[85] AL16
AB14	VSS[7]	VSS[86] AL17
AB39	VSS[8]	VSS[87] AL19
AB4	VSS[9]	VSS[88] AL2
AB43	VSS[10]	VSS[89] AL21
AB5	VSS[11]	VSS[90] AL23
AB7	VSS[12]	VSS[91] AL26
AC19	VSS[13]	VSS[92] AL27
AC2	VSS[14]	VSS[93] AL31
AC21	VSS[15]	VSS[94] AL33
AC24	VSS[16]	VSS[95] AL34
AC33	VSS[17]	VSS[96] AL48
AC34	VSS[18]	VSS[97] AM11
AD12	VSS[19]	VSS[98] AM14
AD10	VSS[20]	VSS[99] AM36
AD11	VSS[21]	VSS[100] AM39
AD12	VSS[22]	VSS[101] AM43
AD13	VSS[23]	VSS[102] AM45
AD19	VSS[24]	VSS[103] AM46
AD24	VSS[25]	VSS[104] AM7
AD26	VSS[26]	VSS[105] AN2
AD27	VSS[27]	VSS[106] AN29
AD33	VSS[28]	VSS[107] AN3
AD34	VSS[29]	VSS[108] AN31
AD36	VSS[30]	VSS[109] AP12
AD37	VSS[31]	VSS[110] AP19
AD38	VSS[32]	VSS[111] AP28
AD39	VSS[33]	VSS[112] AP30
AD4	VSS[34]	VSS[113] AP32
AD40	VSS[35]	VSS[114] AP38
AD42	VSS[36]	VSS[115] AP4
AD43	VSS[37]	VSS[116] AP42
AD45	VSS[38]	VSS[117] AP6
AD46	VSS[39]	VSS[118] AR2
AE2	VSS[41]	VSS[120] AR48
AE3	VSS[42]	VSS[121] AT11
AF10	VSS[43]	VSS[122] AT18
AF12	VSS[44]	VSS[123] AT22
AD14	VSS[45]	VSS[124] AT26
AF16	VSS[46]	VSS[125] AT28
AF19	VSS[47]	VSS[126] AT30
AF24	VSS[48]	VSS[127] AT32
AF26	VSS[49]	VSS[128] AT34
AF26	VSS[50]	VSS[129] AT39
AF27	VSS[51]	VSS[130] AT42
AF29	VSS[52]	VSS[131] AT46
AF31	VSS[53]	VSS[132] AT7
AF38	VSS[54]	VSS[133] AU24
AF4	VSS[55]	VSS[134] AU00
AF42	VSS[56]	VSS[135] AV16
AF46	VSS[57]	VSS[136] AV20
AF5	VSS[58]	VSS[137] AV24
AF7	VSS[59]	VSS[138] AV30
AG19	VSS[60]	VSS[139] AV38
AG2	VSS[62]	VSS[140] AV4
AG31	VSS[63]	VSS[141] AV43
AG48	VSS[64]	VSS[142] AV8
AH11	VSS[65]	VSS[143] AW14
AH3	VSS[66]	VSS[144] AW18
AH36	VSS[67]	VSS[145] AW2
AH40	VSS[68]	VSS[146] AW22
AH42	VSS[69]	VSS[147] AW28
AH46	VSS[70]	VSS[148] AW28
AH7	VSS[71]	VSS[149] AW32
AJ19	VSS[72]	VSS[150] AW34
AJ21	VSS[73]	VSS[151] AW38
AJ24	VSS[74]	VSS[152] AW40
AJ24	VSS[75]	VSS[153] AW48
AJ33	VSS[76]	VSS[154] AV11
AJ34	VSS[77]	VSS[155] AY12
AK12	VSS[78]	VSS[156] AY22
AK3	VSS[79]	VSS[157] AY28
		VSS[158]

PANTHER-POINT_FCBGA989

UH1I		
AY4	VSS[159]	VSS[259] H46
AY42	VSS[160]	VSS[260] K18
AY48	VSS[161]	VSS[261] K26
AY8	VSS[162]	VSS[262] K39
B11	VSS[163]	VSS[263] K46
B15	VSS[164]	VSS[264] K7
B19	VSS[165]	VSS[265] L18
B23	VSS[166]	VSS[266] L2
B27	VSS[167]	VSS[267] L20
B31	VSS[168]	VSS[268] L26
B35	VSS[169]	VSS[269] L28
B39	VSS[170]	VSS[270] L36
B7	VSS[171]	VSS[271] L48
F45	VSS[172]	VSS[272] M12
BB12	VSS[173]	VSS[273] P16
BB16	VSS[174]	VSS[274] M18
BB20	VSS[175]	VSS[275] M22
BB22	VSS[176]	VSS[276] M24
BB24	VSS[177]	VSS[277] M30
BB28	VSS[178]	VSS[278] M32
BB30	VSS[179]	VSS[279] M34
BB38	VSS[180]	VSS[280] M38
BB4	VSS[181]	VSS[281] M4
BB46	VSS[182]	VSS[282] M42
BC14	VSS[183]	VSS[283] M46
BC18	VSS[184]	VSS[284] M8
BC2	VSS[185]	VSS[285] N18
BC22	VSS[186]	VSS[286] P20
BC26	VSS[187]	VSS[287] N47
BC32	VSS[188]	VSS[288] P11
BC34	VSS[189]	VSS[289] P18
BC36	VSS[190]	VSS[290] T33
BC40	VSS[191]	VSS[291] P40
BC42	VSS[192]	VSS[292] P43
BC48	VSS[193]	VSS[293] P47
BD5	VSS[194]	VSS[294] P7
BE22	VSS[195]	VSS[295] R48
BE26	VSS[196]	VSS[296] T12
BE26	VSS[197]	VSS[297] T12
BE40	VSS[198]	VSS[298] T31
BF10	VSS[199]	VSS[299] T37
BF12	VSS[200]	VSS[300] T4
BF16	VSS[201]	VSS[301] W34
BF20	VSS[202]	VSS[302] T46
BF22	VSS[203]	VSS[303] T47
BF24	VSS[204]	VSS[304] T8
BF26	VSS[205]	VSS[305] V11
BF28	VSS[206]	VSS[306] V17
BD3	VSS[207]	VSS[307] V26
BF30	VSS[208]	VSS[308] V27
BF38	VSS[209]	VSS[309] V29
BF40	VSS[210]	VSS[310] V31
BF8	VSS[211]	VSS[311] V36
BG17	VSS[212]	VSS[312] V39
BG21	VSS[213]	VSS[313] V43
BG33	VSS[214]	VSS[314] V7
BG44	VSS[215]	VSS[315] W17
BG8	VSS[216]	VSS[316] W19
BH11	VSS[217]	VSS[317] W2
BH15	VSS[218]	VSS[318] W27
BH17	VSS[219]	VSS[319] W48
H10	VSS[220]	VSS[320] Y12
H10	VSS[221]	VSS[321] Y38
BH27	VSS[222]	VSS[322] Y4
BH31	VSS[223]	VSS[323] Y42
BH33	VSS[224]	VSS[324] Y46
BH35	VSS[225]	VSS[325] Y8
BH39	VSS[226]	VSS[326] BG29
BH43	VSS[227]	VSS[327] N24
BH7	VSS[228]	VSS[328] A33
D3	VSS[229]	VSS[329] AD47
D12	VSS[230]	VSS[330] B43
D16	VSS[231]	VSS[331] BE10
D18	VSS[232]	VSS[332] BG41
D22	VSS[233]	VSS[333] G14
D24	VSS[234]	VSS[334] H16
D26	VSS[235]	VSS[335] T36
D30	VSS[236]	VSS[336] BG22
D32	VSS[237]	VSS[337] CG24
D34	VSS[238]	VSS[338] C22
D38	VSS[239]	VSS[339] AP13
D42	VSS[240]	VSS[340] M14
D8	VSS[241]	VSS[341] AP3
E18	VSS[242]	VSS[342] AP1
E26	VSS[243]	VSS[343] BE16
G18	VSS[244]	VSS[344] BC16
G20	VSS[245]	VSS[345] CG28
G26	VSS[246]	VSS[346] BL28
G28	VSS[247]	VSS[347]
G36	VSS[248]	VSS[348]
G48	VSS[249]	VSS[349]
H12	VSS[250]	VSS[350]
H18	VSS[251]	VSS[351]
H22	VSS[252]	VSS[352]
H24	VSS[253]	
H26	VSS[254]	
H30	VSS[255]	
H32	VSS[256]	
H34	VSS[257]	
F3	VSS[258]	

PANTHER-POINT_FCBGA989

Security Classification	Compal Secret Data		Title	
Issued Date	2011/05/23	Deciphered Date	2012/12/31	
THIS SHEET OF ENGINEERING DRAWING IS THE PROPRIETARY PROPERTY OF COMPAL ELECTRONICS, INC. AND CONTAINS CONFIDENTIAL AND TRADE SECRET INFORMATION. THIS SHEET MAY NOT BE TRANSFERRED FROM THE CUSTODY OF THE COMPETENT DIVISION OF R&D DEPARTMENT EXCEPT AS AUTHORIZED BY COMPAL ELECTRONICS, INC. NEITHER THIS SHEET NOR THE INFORMATION IT CONTAINS MAY BE USED BY OR DISCLOSED TO ANY THIRD PARTY WITHOUT PRIOR WRITTEN CONSENT OF COMPAL ELECTRONICS, INC.				
Compal Electronics, Inc. PCH (3/8) VSS			Size	Rev
Customer QAL51, LA-7871P MB			1.0	
Date:	Wednesday, March 07, 2012		Sheet	19 of 60

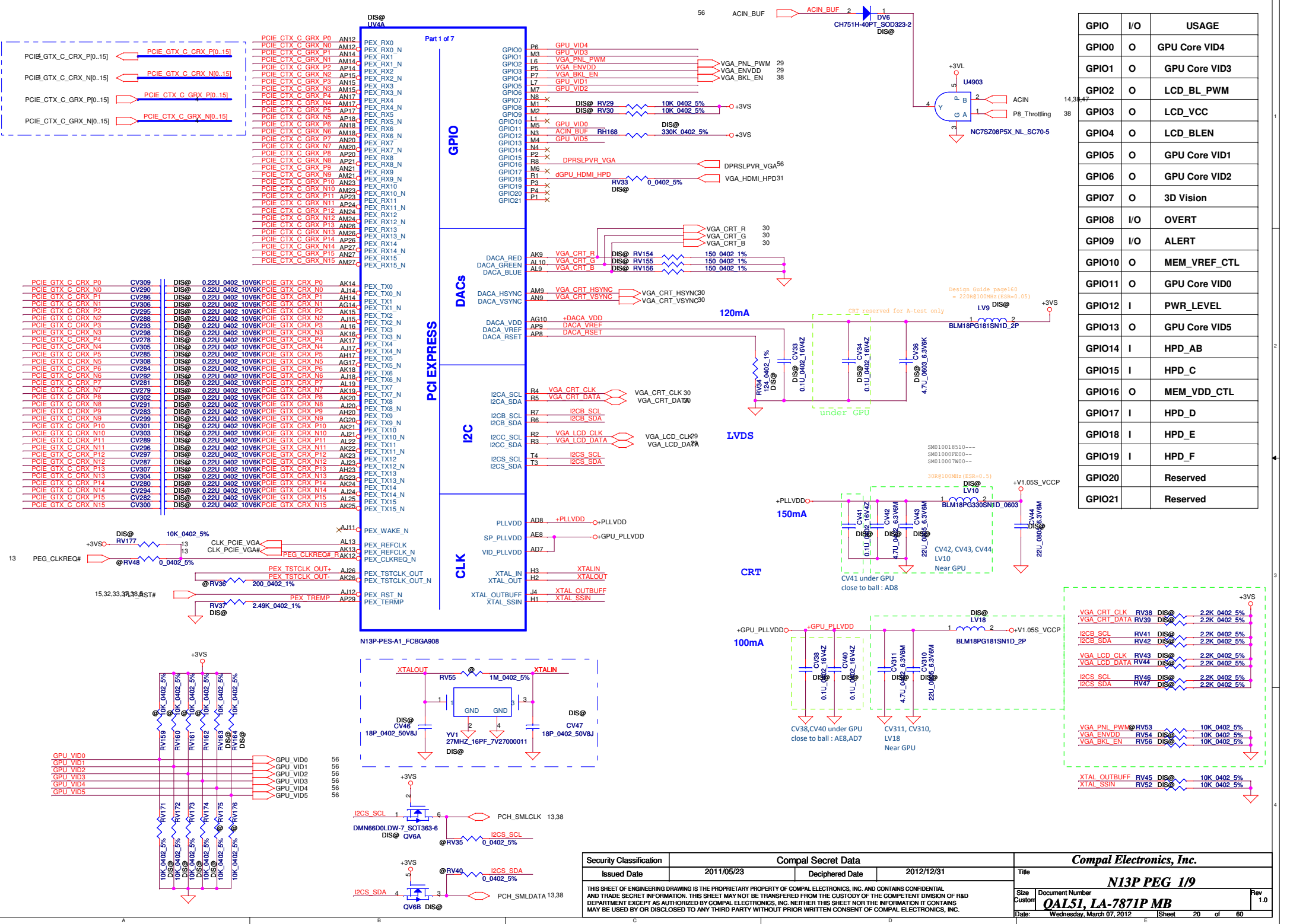

Security Classification	Compal Secret Data	
Issued Date	2011/05/23	Deciphered Date
		2012/12/31

THIS SHEET OF ENGINEERING DRAWING IS THE PROPRIETARY PROPERTY OF COMPAL ELECTRONICS, INC. AND CONTAINS CONFIDENTIAL AND TRADE SECRET INFORMATION. THIS SHEET MAY NOT BE TRANSFERRED FROM THE CUSTODY OF THE COMPETENT DIVISION OF R&D DEPARTMENT EXCEPT AS AUTHORIZED BY COMPAL ELECTRONICS, INC. NEITHER THIS SHEET NOR THE INFORMATION IT CONTAINS MAY BE USED BY OR DISCLOSED TO ANY THIRD PARTY WITHOUT PRIOR WRITTEN CONSENT OF COMPAL ELECTRONICS, INC.

Compal Electronics, Inc.			
N13P PEG 1/9			
Title	Document Number	Rev	
	QALS1, LA-7871P MB	1.0	
Date:	Wednesday, March 07, 2012	Sheet	20 of 60

VRAM Interface

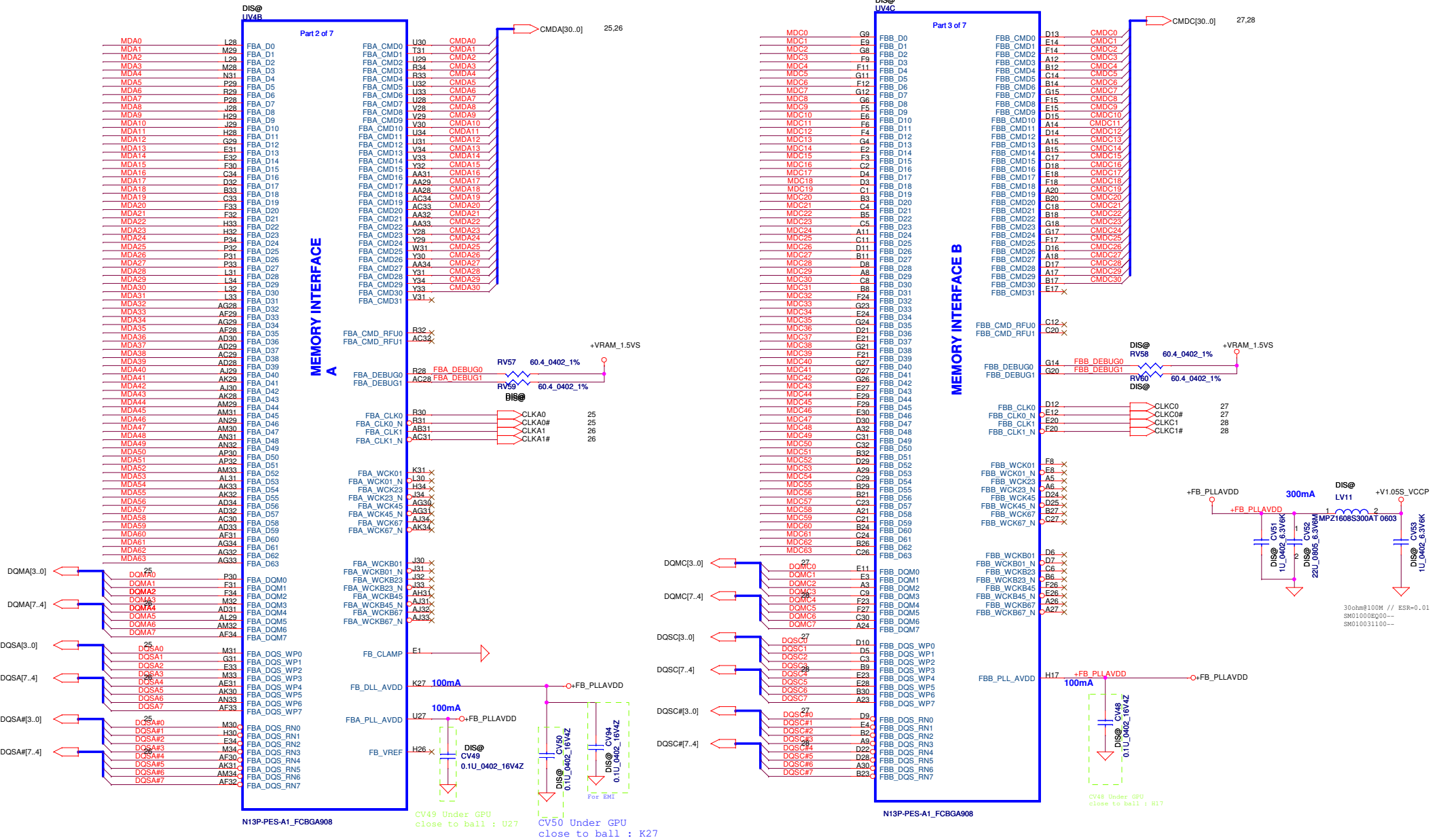
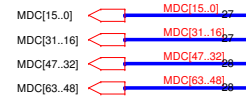
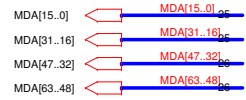

N13P-PES-A1_FCBGA908

CV49 Under GPU close to ball : U27
 CV50 Under GPU close to ball : K27

N13P-PES-A1_FCBGA908

CV48 Under GPU close to ball : H17

Security Classification	Compal Secret Data		Compal Electronics, Inc.	
Issued Date	2011/05/23	Deciphered Date	2012/12/31	
THIS SHEET OF ENGINEERING DRAWING IS THE PROPRIETARY PROPERTY OF COMPAL ELECTRONICS, INC. AND CONTAINS CONFIDENTIAL AND TRADE SECRET INFORMATION. THIS SHEET MAY NOT BE TRANSFERRED FROM THE CUSTODY OF THE COMPETENT DIVISION OF R&D DEPARTMENT EXCEPT AS AUTHORIZED BY COMPAL ELECTRONICS, INC. NEITHER THIS SHEET NOR THE INFORMATION IT CONTAINS MAY BE USED BY OR DISCLOSED TO ANY THIRD PARTY WITHOUT PRIOR WRITTEN CONSENT OF COMPAL ELECTRONICS, INC.				
Title	N13P VRAM 2/9			
Size	Document Number	Rev		1.0
Customer	QAL51, LA-7871P MB			
Date	Wednesday, March 07, 2012	Sheet	21	of 60

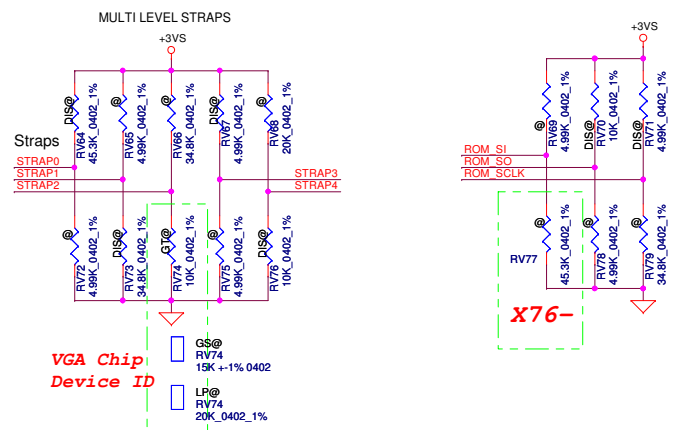
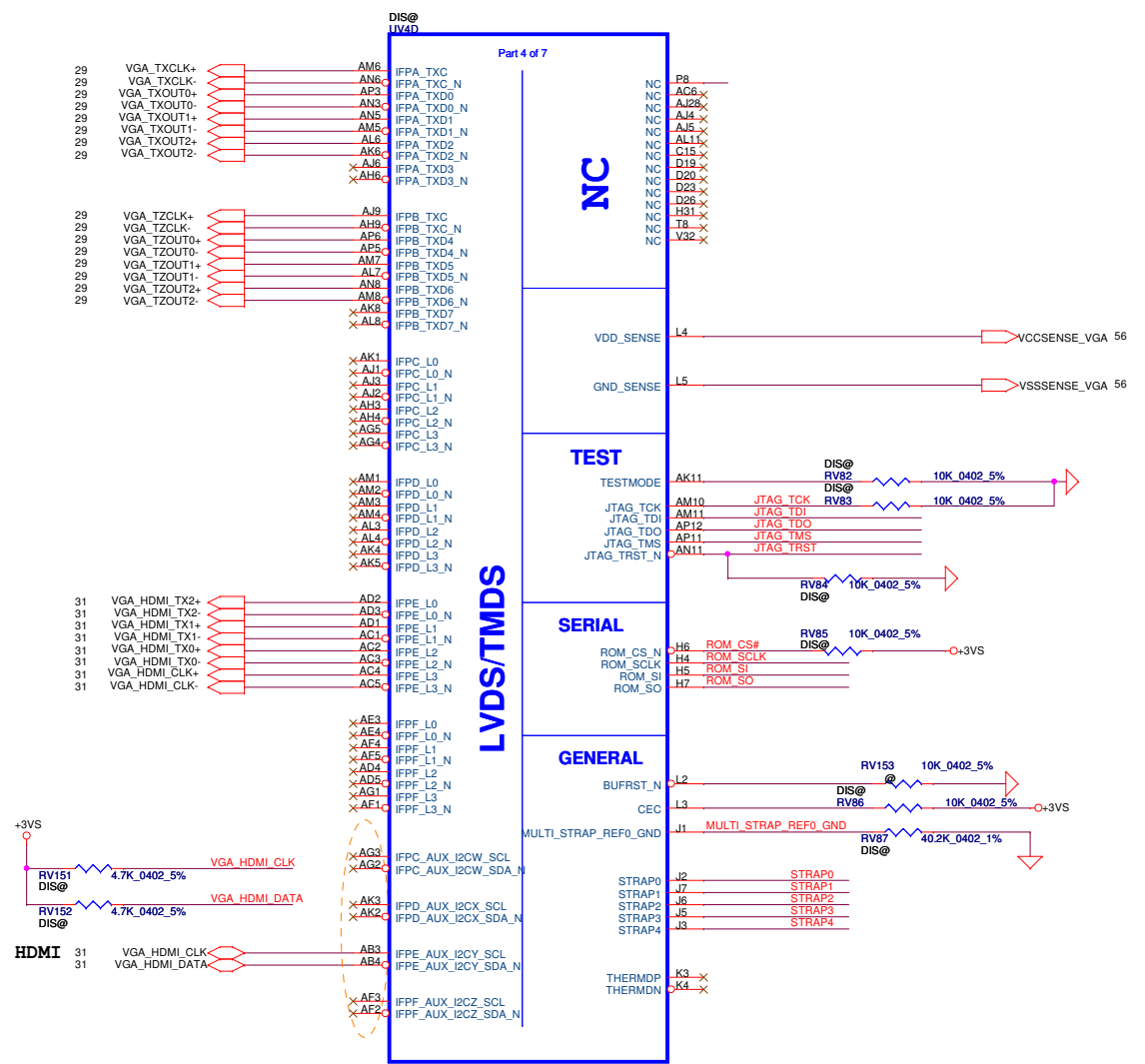

For N13P-GS/GT/LP strap table

GPU	Freq.	Memory Size	Memory Config	strap0	strap1	strap2	strap3	strap4	ROM_SI	ROM_SO	ROM_SCLK
N13P-GS	900 MHz	64M* 16* 8 1GB	Hynix SA000041S20	RV64 PU 45K	RV73 PD 35K	RV74 PD 15K	RV67 PU 5K	RV76 PD 10K	RV77 PD 15K	RV70 PU 10K	RV71 PU 5K
	900 MHz	64M* 16* 8 1GB	Samsung SA00004GS00	RV64 PU 45K	RV73 PD 35K	RV74 PD 15K	RV67 PU 5K	RV76 PD 10K	RV77 PD 20K	RV70 PU 10K	RV71 PU 5K
	900 MHz	128M* 16* 8 2GB	Hynix SA00003Y000	RV64 PU 45K	RV73 PD 35K	RV74 PD 15K	RV67 PU 5K	RV76 PD 10K	RV77 PD 35K	RV70 PU 10K	RV71 PU 5K
	900 MHz	128M* 16* 8 2GB	Samsung SA000047Q00	RV64 PU 45K	RV73 PD 35K	RV74 PD 15K	RV67 PU 5K	RV76 PD 10K	RV77 PD 45K	RV70 PU 10K	RV71 PU 5K
N13P-GT	900 MHz	64M* 16* 8 1GB	Hynix SA000041S20	RV64 PU 45K	RV73 PD 35K	RV74 PD 10K	RV67 PU 5K	RV76 PD 10K	RV77 PD 15K	RV70 PU 10K	RV71 PU 5K
	900 MHz	64M* 16* 8 1GB	Samsung SA00004GS00	RV64 PU 45K	RV73 PD 35K	RV74 PD 10K	RV67 PU 5K	RV76 PD 10K	RV77 PD 20K	RV70 PU 10K	RV71 PU 5K
	900 MHz	128M* 16* 8 2GB	Hynix SA00003Y000	RV64 PU 45K	RV73 PD 35K	RV74 PD 10K	RV67 PU 5K	RV76 PD 10K	RV77 PD 35K	RV70 PU 10K	RV71 PU 5K
	900 MHz	128M* 16* 8 2GB	Samsung SA000047Q00	RV64 PU 45K	RV73 PD 35K	RV74 PD 10K	RV67 PU 5K	RV76 PD 10K	RV77 PD 45K	RV70 PU 10K	RV71 PU 5K
N13P-LP	900 MHz	64M* 16* 8 1GB	Hynix SA000041S20	RV64 PU 45K	RV73 PD 35K	RV74 PD 20K	RV67 PU 5K	RV76 PD 10K	RV77 PD 15K	RV70 PU 10K	RV71 PU 5K
	900 MHz	64M* 16* 8 1GB	Samsung SA00004GS00	RV64 PU 45K	RV73 PD 35K	RV74 PD 20K	RV67 PU 5K	RV76 PD 10K	RV77 PD 20K	RV70 PU 10K	RV71 PU 5K
	900 MHz	128M* 16* 8 2GB	Hynix SA00003Y000	RV64 PU 45K	RV73 PD 35K	RV74 PD 20K	RV67 PU 5K	RV76 PD 10K	RV77 PD 35K	RV70 PU 10K	RV71 PU 5K
	900 MHz	128M* 16* 8 2GB	Samsung SA000047Q00	RV64 PU 45K	RV73 PD 35K	RV74 PD 20K	RV67 PU 5K	RV76 PD 10K	RV77 PD 45K	RV70 PU 10K	RV71 PU 5K

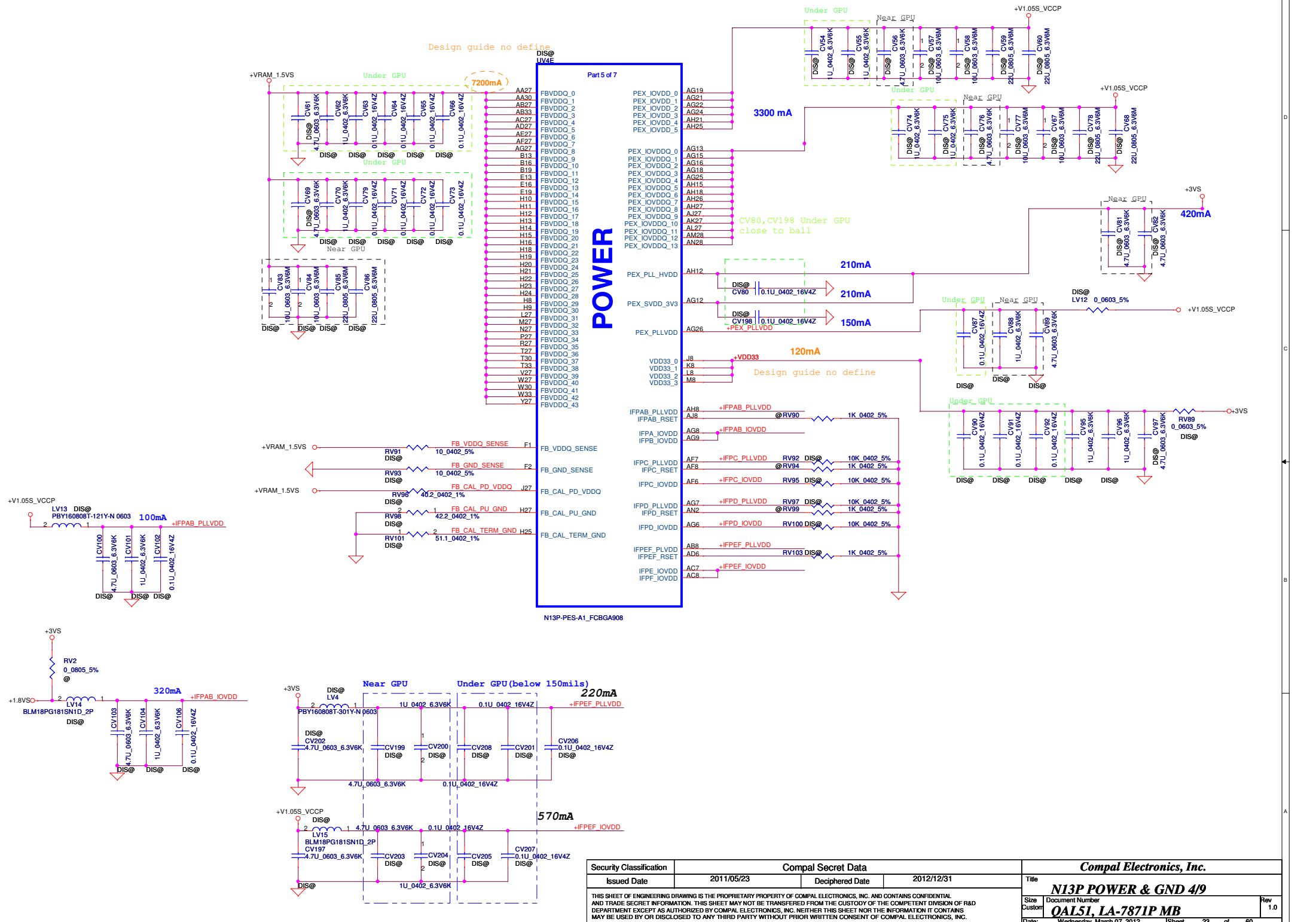

Security Classification		Compal Secret Data	
Issued Date	2011/05/23	Deciphered Date	2012/12/31

THIS SHEET OF ENGINEERING DRAWING IS THE PROPRIETARY PROPERTY OF COMPAL ELECTRONICS, INC. AND CONTAINS CONFIDENTIAL AND TRADE SECRET INFORMATION. THIS SHEET MAY NOT BE TRANSFERRED FROM THE CUSTODY OF THE COMPETENT DIVISION OF R&D DEPARTMENT EXCEPT AS AUTHORIZED BY COMPAL ELECTRONICS, INC. NEITHER THIS SHEET NOR THE INFORMATION IT CONTAINS MAY BE USED BY OR DISCLOSED TO ANY THIRD PARTY WITHOUT PRIOR WRITTEN CONSENT OF COMPAL ELECTRONICS, INC.

Compal Electronics, Inc.		
Title N13P POWER & GND 4/9		
Size Customer	Document Number QAL51_LA-7871P MB	Rev 1.0
Date:	Wednesday, March 07, 2012	Sheet 23 of 60

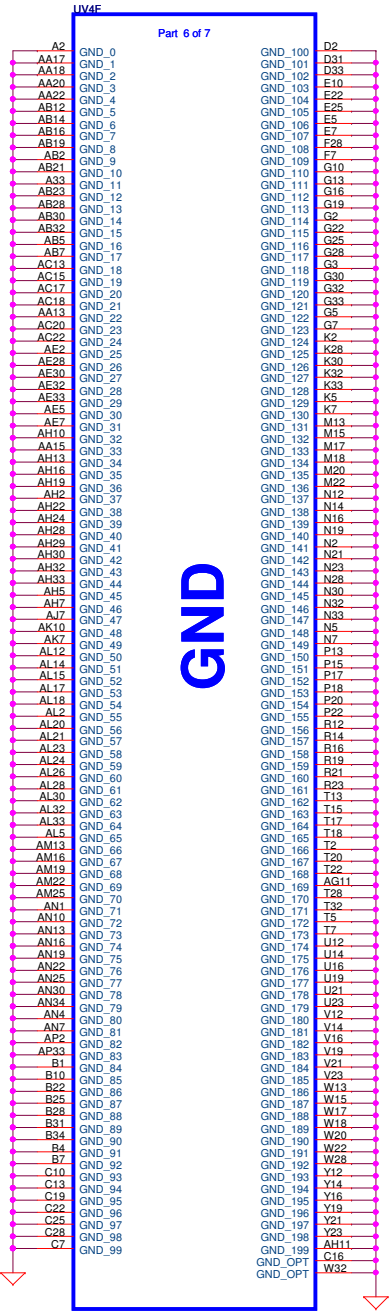

N13P-PES-A1_FCBGA908

DIS@

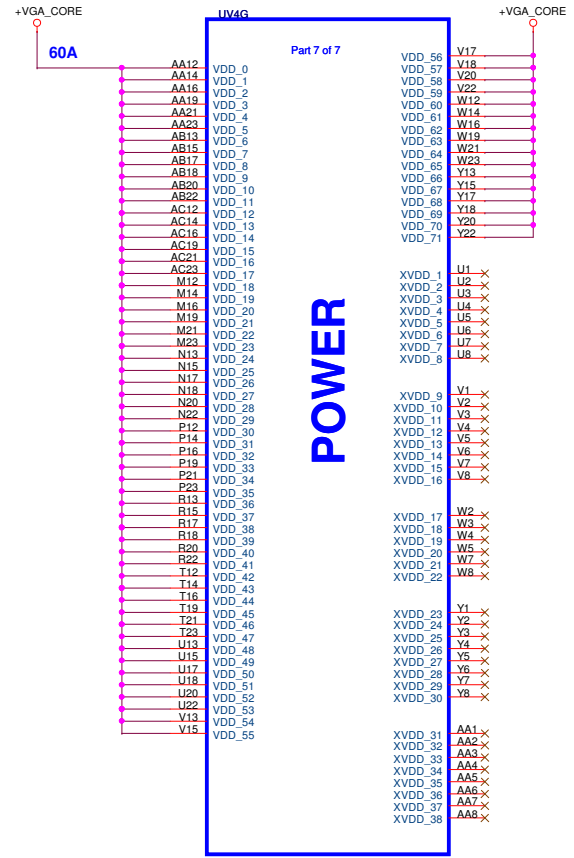

N13P-PES-A1_FCBGA908

DIS@

Security Classification		Compal Secret Data		Compal Electronics, Inc.	
Issued Date	2011/05/23	Deciphered Date	2012/12/31	Title	
THIS SHEET OF ENGINEERING DRAWING IS THE PROPRIETARY PROPERTY OF COMPAL ELECTRONICS, INC. AND CONTAINS CONFIDENTIAL AND TRADE SECRET INFORMATION. THIS SHEET MAY NOT BE TRANSFERRED FROM THE CUSTODY OF THE COMPETENT DIVISION OF R&D DEPARTMENT EXCEPT AS AUTHORIZED BY COMPAL ELECTRONICS, INC. NEITHER THIS SHEET NOR THE INFORMATION IT CONTAINS MAY BE USED BY OR DISCLOSED TO ANY THIRD PARTY WITHOUT PRIOR WRITTEN CONSENT OF COMPAL ELECTRONICS, INC.				N13P POWER & GND 5/9	
Size	Document Number	Date:		Rev	1.0
Custome	QAL51, LA-7871P MB	Wednesday, March 07, 2012		Sheet	24 of 60

VRAM DDR3 chips (1GB)

64Mx16 DDR3 *8==>1GB
128Mx16 DDR3 *8==>2GB

Mode D Address	0..31	32..63
CMD0	CS0_L#	
CMD1		
CMD2	ODT_L	
CMD3	CKE	
CMD4	A14	A14
CMD5	RST	RST
CMD6	A9	A9
CMD7	A7	A7
CMD8	A2	A2
CMD9	A0	A0
CMD10	A4	A4
CMD11	A1	A1
CMD12	BA0	BA0
CMD13	WE*	WE*
CMD14	A15	A15
CMD15	CAS*	CAS*
CMD16		CS0_H#
CMD17		
CMD18		ODT_H
CMD19		CKE_H
CMD20	A13	A13
CMD21	A8	A8
CMD22	A6	A6
CMD23	A11	A11
CMD24	A5	A5
CMD25	A3	A3
CMD26	BA2	BA2
CMD27	BA1	BA1
CMD28	A12	A12
CMD29	A10	A10
CMD30	RAS*	RAS*
Not Available	LOW	HIGH

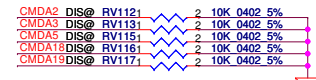
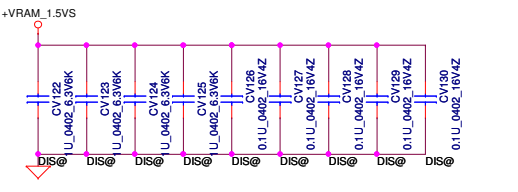
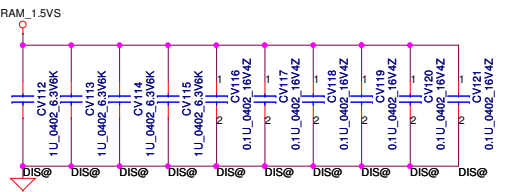
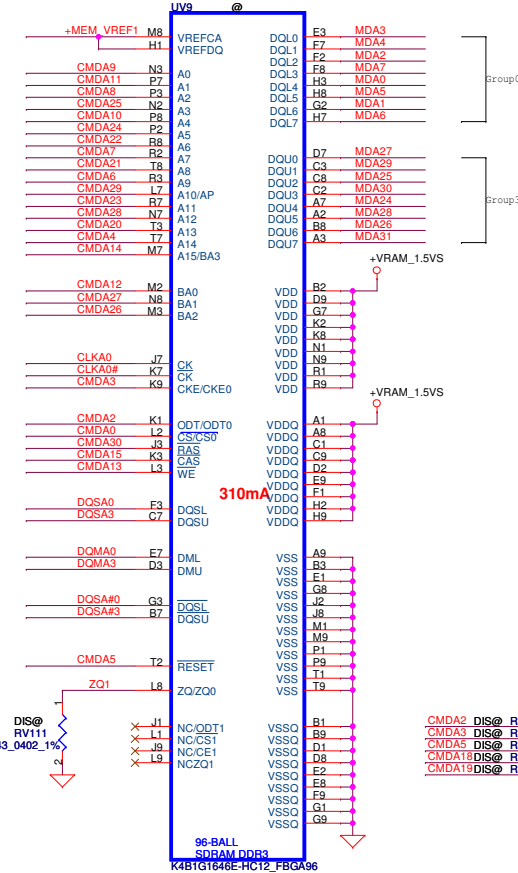
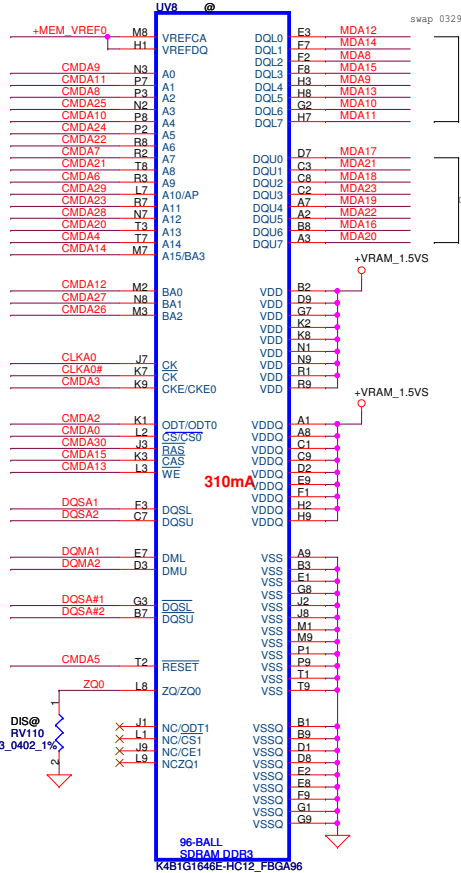
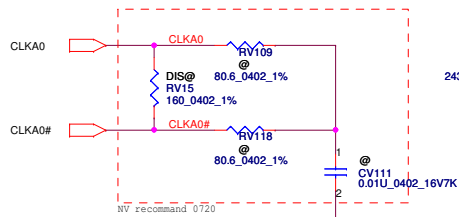
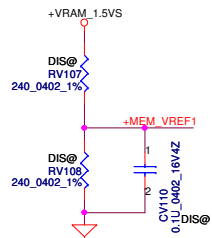
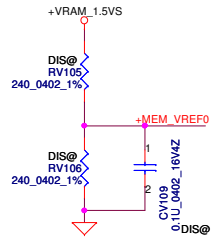
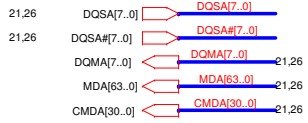

Command Bit	Default Pull-down
ODT#	10k
CKE	10k
RST	10k
CAS*	No Termination

Samsung : SA000035700 (S IC D3 64Mx16 K4W1G1646E-HC12 FBGA 96P)
 Hynix : SA000032400 (S IC D3 64Mx16 H5TQ1G63BFR-12C FBGA 1.5V)
 AMD :SA00003PF10
 (S IC D3 64M16/800 23EY2387MB-12 PG-TFPGA 96P 1.5V)

Security Classification		Compal Secret Data		Compal Electronics, Inc.	
Issued Date	2011/05/23	Deciphered Date	2012/12/31	Title	
				N13P DDR3 6/9	
				Size	Document Number
				QALS1_LA-7871P MB	
				Date	Wednesday, March 07, 2012
				Sheet	25 of 60

THIS SHEET OF ENGINEERING DRAWING IS THE PROPRIETARY PROPERTY OF COMPAL ELECTRONICS, INC. AND CONTAINS CONFIDENTIAL AND TRADE SECRET INFORMATION. THIS SHEET MAY NOT BE TRANSFERRED FROM THE CUSTODY OF THE COMPETENT DIVISION OF R&D DEPARTMENT EXCEPT AS AUTHORIZED BY COMPAL ELECTRONICS, INC. NEITHER THIS SHEET NOR THE INFORMATION IT CONTAINS MAY BE USED BY OR DISCLOSED TO ANY THIRD PARTY WITHOUT PRIOR WRITTEN CONSENT OF COMPAL ELECTRONICS, INC.

VRAM DDR3 chips (1GB)

64Mx16 DDR3 *8==>1GB

128Mx16 DDR3 *8==>2GB

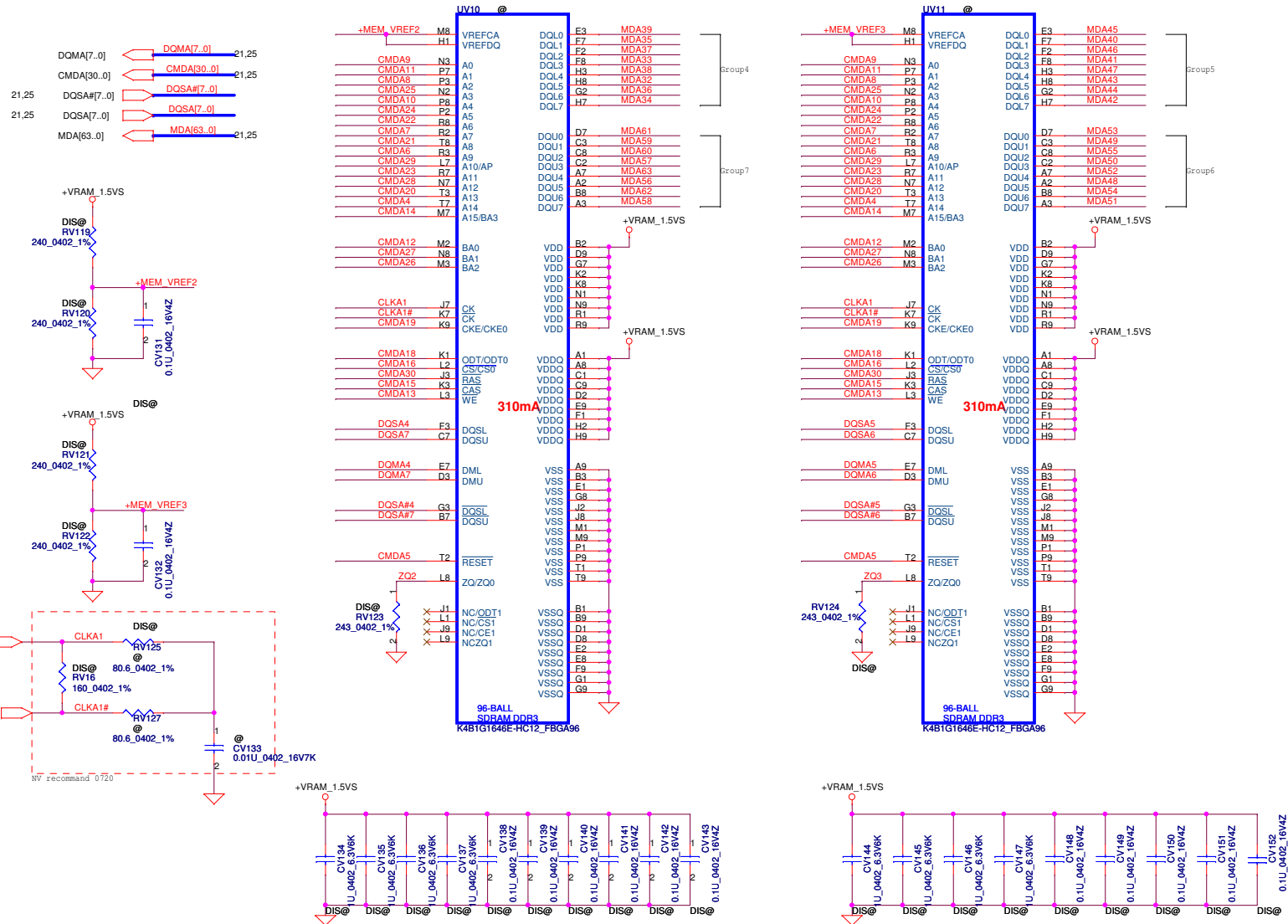

Mode D Address	0..31	32..63
CMD0	CS0_L#	
CMD1		
CMD2	ODT_L	
CMD3	CKE	
CMD4	A14	A14
CMD5	RST	RST
CMD6	A9	A9
CMD7	A7	A7
CMD8	A2	A2
CMD9	A0	A0
CMD10	A4	A4
CMD11	A1	A1
CMD12	BA0	BA0
CMD13	WE*	WE*
CMD14	A15	A15
CMD15	CAS*	CAS*
CMD16		CS0_H#
CMD17		
CMD18		ODT_H
CMD19		CKE_H
CMD20	A13	A13
CMD21	A8	A8
CMD22	A6	A6
CMD23	A11	A11
CMD24	A5	A5
CMD25	A3	A3
CMD26	BA2	BA2
CMD27	BA1	BA1
CMD28	A12	A12
CMD29	A10	A10
CMD30	RAS*	RAS*
Not Available		
		LOW HIGH

VRAM DDR3 chips (1GB)

64Mx16 DDR3 *8==>1GB

128Mx16 DDR3 *8==>2GB

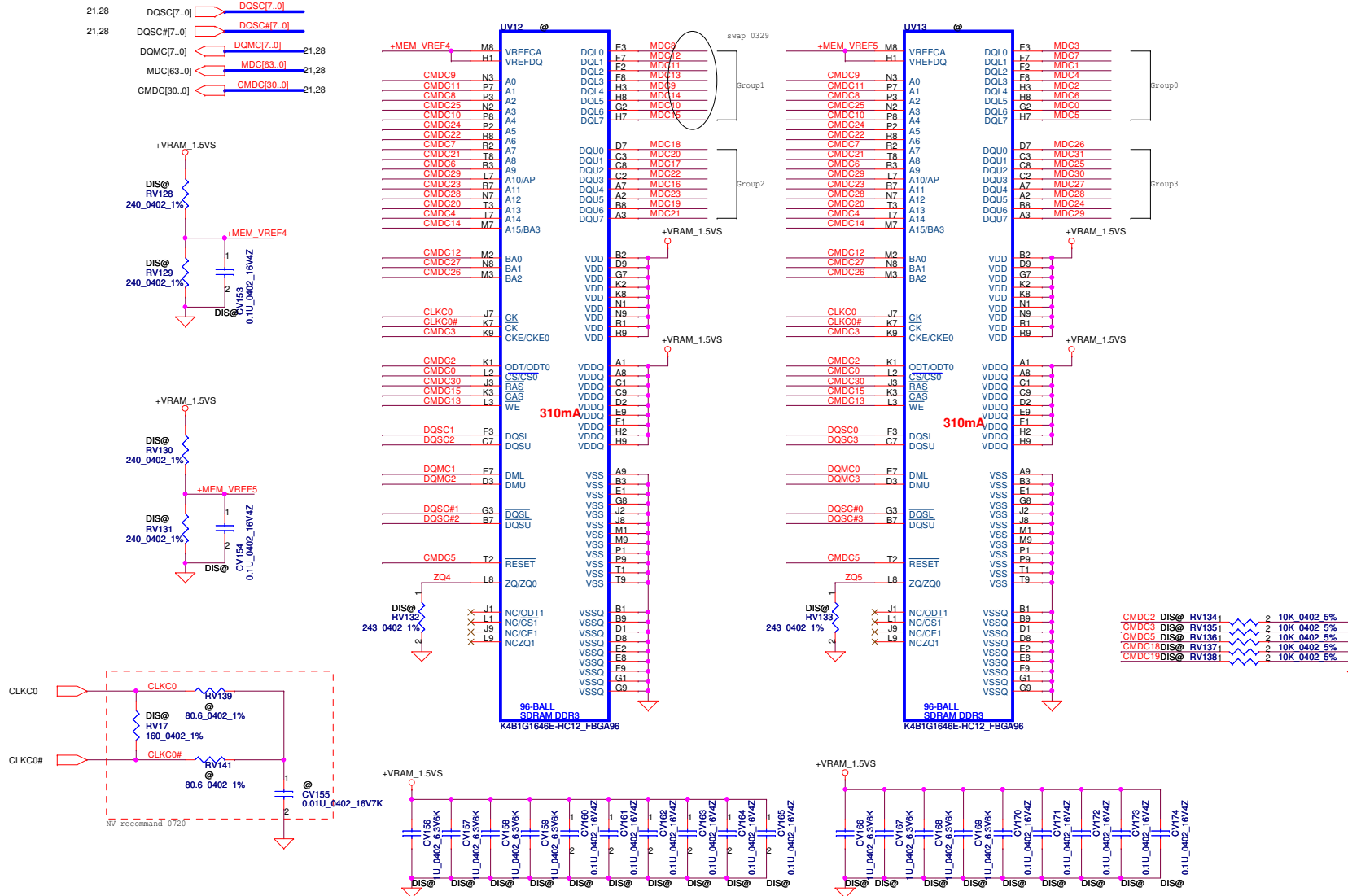

Mode D Address	0..31	32..63
CMD0	CS0_L#	
CMD1		
CMD2	ODT_L	
CMD3	CKE	
CMD4	A14	A14
CMD5	RST	RST
CMD6	A9	A9
CMD7	A7	A7
CMD8	A2	A2
CMD9	A0	A0
CMD10	A4	A4
CMD11	A1	A1
CMD12	BA0	BA0
CMD13	WE*	WE*
CMD14	A15	A15
CMD15	CAS*	CAS*
CMD16		CS0_H#
CMD17		
CMD18		ODT_H
CMD19		CKE_H
CMD20	A13	A13
CMD21	A8	A8
CMD22	A6	A6
CMD23	A11	A11
CMD24	A5	A5
CMD25	A3	A3
CMD26	BA2	BA2
CMD27	BA1	BA1
CMD28	A12	A12
CMD29	A10	A10
CMD30	RAS*	RAS*
Not Available		

Command Bit	Default Pull-down
ODTx	10k
CKEX	10k
RST	10k
CAS*	No Termination

Security Classification	Compal Secret Data			Compal Electronics, Inc.	
Issued Date	2011/05/23	Deciphered Date	2012/12/31	Title N13P DDR3 8/9	
THIS SHEET OF ENGINEERING DRAWING IS THE PROPRIETARY PROPERTY OF COMPAL ELECTRONICS, INC. AND CONTAINS CONFIDENTIAL AND TRADE SECRET INFORMATION. THIS SHEET MAY NOT BE TRANSFERRED FROM THE CUSTODY OF THE COMPETENT DIVISION OF R&D DEPARTMENT EXCEPT AS AUTHORIZED BY COMPAL ELECTRONICS, INC. NEITHER THIS SHEET NOR THE INFORMATION IT CONTAINS MAY BE USED BY OR DISCLOSED TO ANY THIRD PARTY WITHOUT PRIOR WRITTEN CONSENT OF COMPAL ELECTRONICS, INC.				Size Customer QAL51, LA-7871P MB	
				Date:	Wednesday, March 07, 2012 27 of 60

VRAM DDR3 chips (1GB)

64Mx16 DDR3 *8==>1GB

128Mx16 DDR3 *8==>2GB

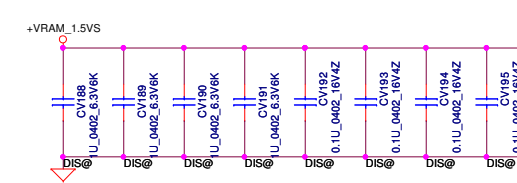
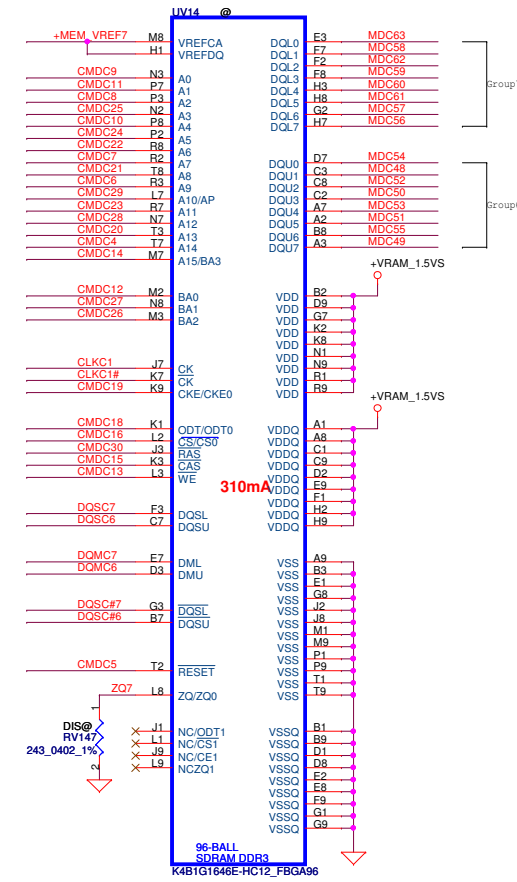
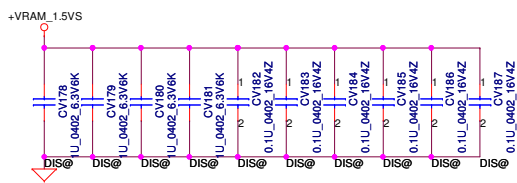
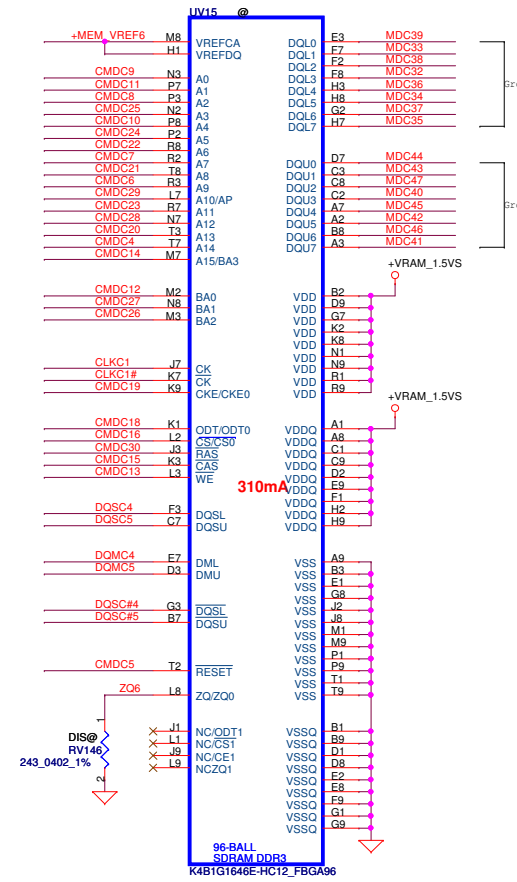
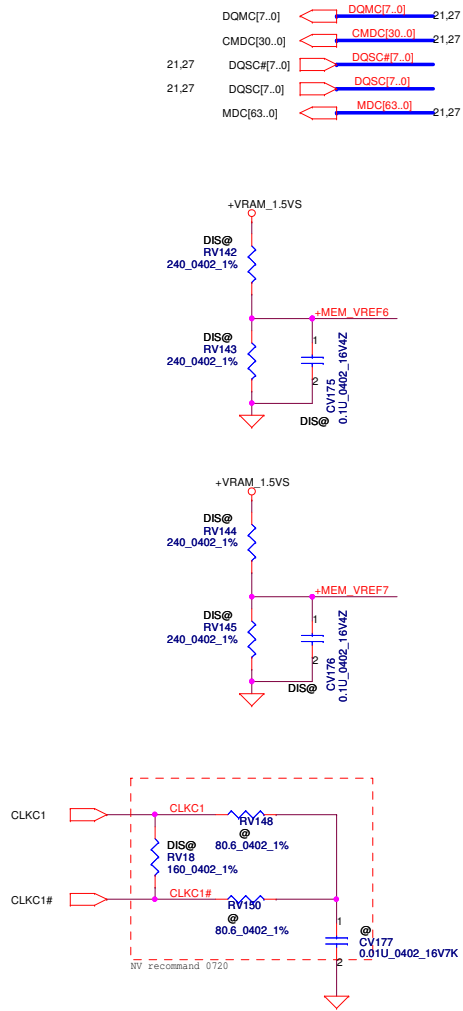

Mode D Address	0..31	32..63
CMD0	CS0_L#	
CMD1		
CMD2	ODT_L	
CMD3	CKE	
CMD4	A14	A14
CMD5	RST	RST
CMD6	A9	A9
CMD7	A7	A7
CMD8	A2	A2
CMD9	A0	A0
CMD10	A4	A4
CMD11	A1	A1
CMD12	BA0	BA0
CMD13	WE*	WE*
CMD14	A15	A15
CMD15	CAS*	CAS*
CMD16		CS0_H#
CMD17		
CMD18		ODT_H
CMD19		CKE_H
CMD20	A13	A13
CMD21	A8	A8
CMD22	A6	A6
CMD23	A11	A11
CMD24	A5	A5
CMD25	A3	A3
CMD26	BA2	BA2
CMD27	BA1	BA1
CMD28	A12	A12
CMD29	A10	A10
CMD30	RAS*	RAS*
Not Available		

LOW HIGH

Security Classification	Compal Secret Data		Compal Electronics, Inc.		
Issued Date	2011/05/23	Deciphered Date	2012/12/31	Title	
THIS SHEET OF ENGINEERING DRAWING IS THE PROPRIETARY PROPERTY OF COMPAL ELECTRONICS, INC. AND CONTAINS CONFIDENTIAL AND TRADE SECRET INFORMATION. THIS SHEET MAY NOT BE TRANSFERRED FROM THE CUSTODY OF THE COMPETENT DIVISION OF R&D DEPARTMENT EXCEPT AS AUTHORIZED BY COMPAL ELECTRONICS, INC. NEITHER THIS SHEET NOR THE INFORMATION IT CONTAINS MAY BE USED BY OR DISCLOSED TO ANY THIRD PARTY WITHOUT PRIOR WRITTEN CONSENT OF COMPAL ELECTRONICS, INC.				Size	N13P DDR3 9/9
				Customer	QAL51, LA-7871P MB
				Date	Wednesday, March 07, 2012
				Sheet	28 of 60
				Rev	1.0

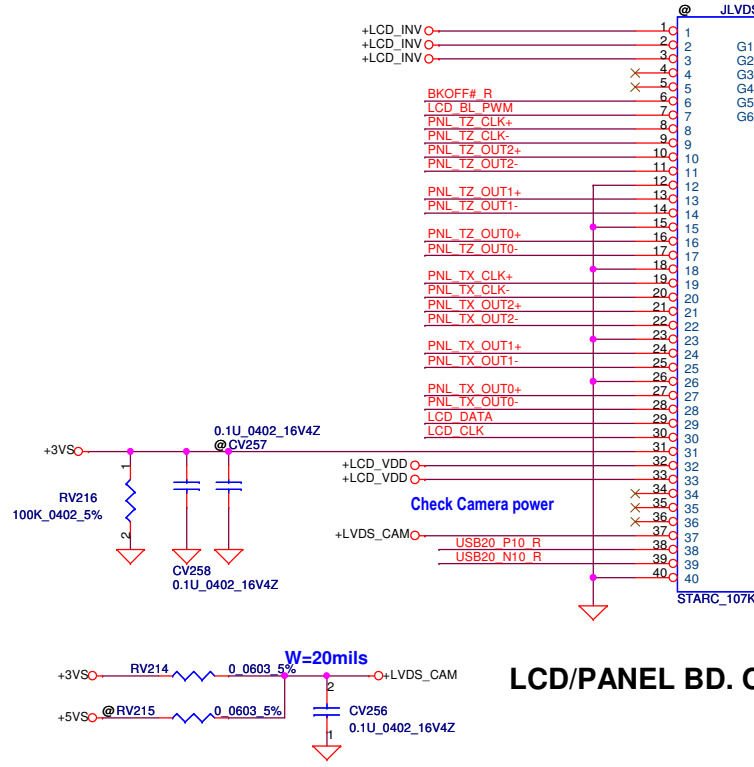
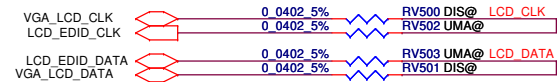
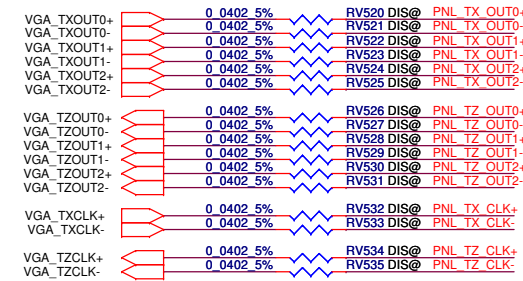
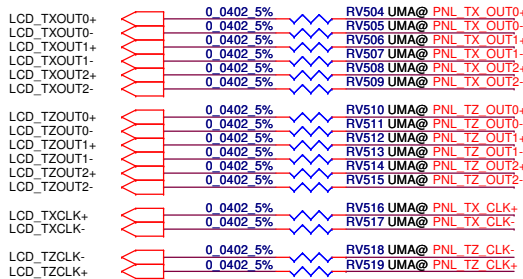
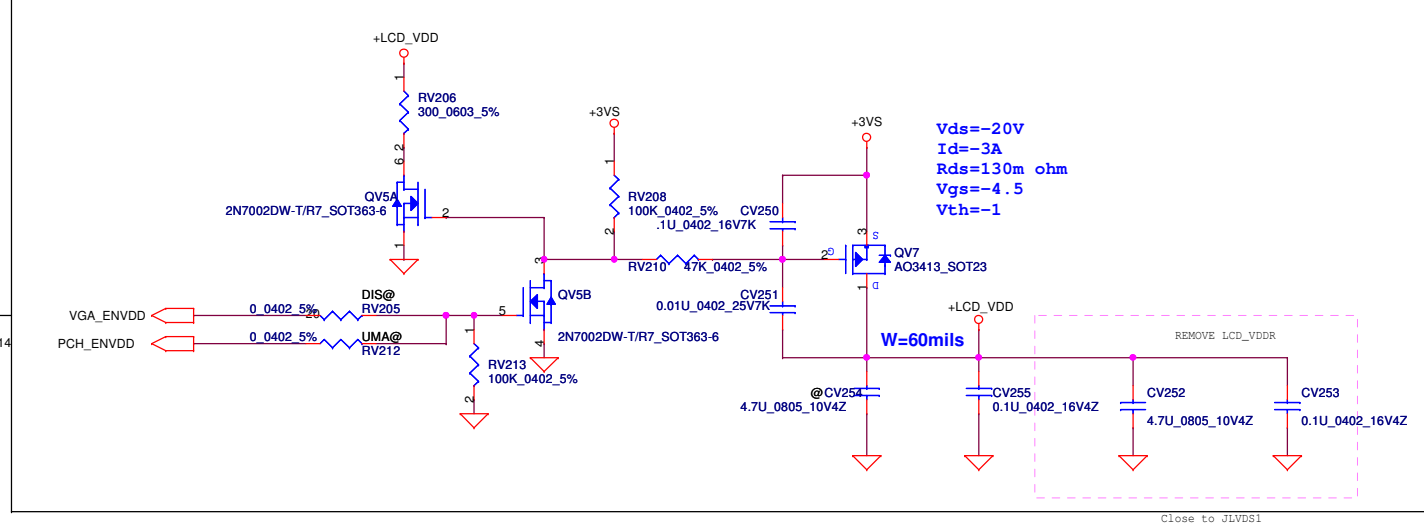
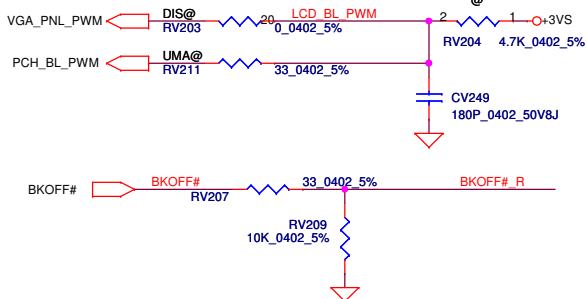

LCD/PANEL BD. Conn.

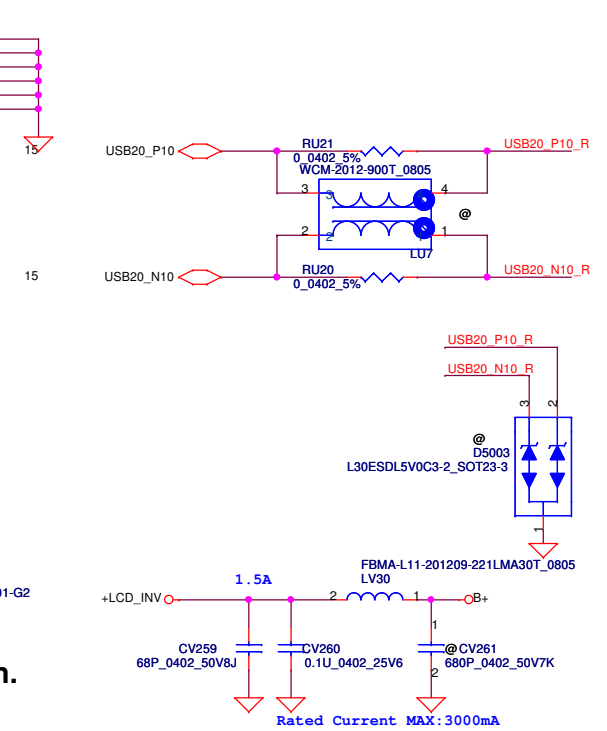

Security Classification	Compal Secret Data		Compal Electronics, Inc.	
Issued Date	2011/05/23	Deciphered Date	2012/12/31	Title
THIS SHEET OF ENGINEERING DRAWING IS THE PROPRIETARY PROPERTY OF COMPAL ELECTRONICS, INC. AND CONTAINS CONFIDENTIAL AND TRADE SECRET INFORMATION. THIS SHEET MAY NOT BE TRANSFERRED FROM THE CUSTODY OF THE COMPETENT DIVISION OF R&D DEPARTMENT EXCEPT AS AUTHORIZED BY COMPAL ELECTRONICS, INC. NEITHER THIS SHEET NOR THE INFORMATION IT CONTAINS MAY BE USED BY OR DISCLOSED TO ANY THIRD PARTY WITHOUT PRIOR WRITTEN CONSENT OF COMPAL ELECTRONICS, INC.				Size QAL51, LA-7871P MB
Date: Wednesday, March 07, 2012				Sheet 29 of 60

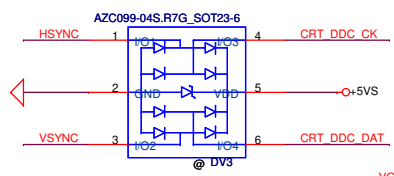
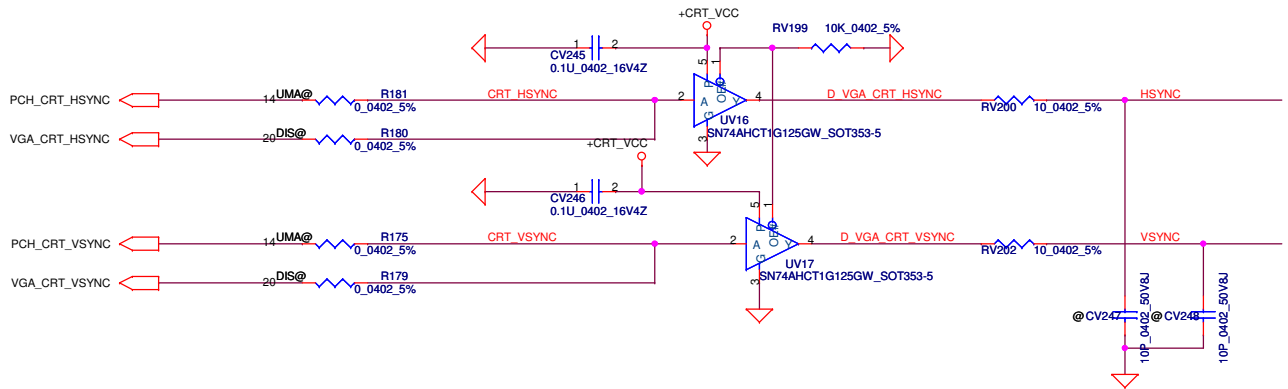
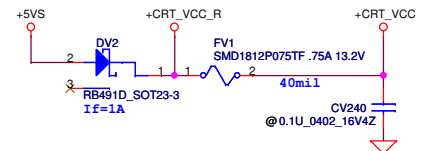
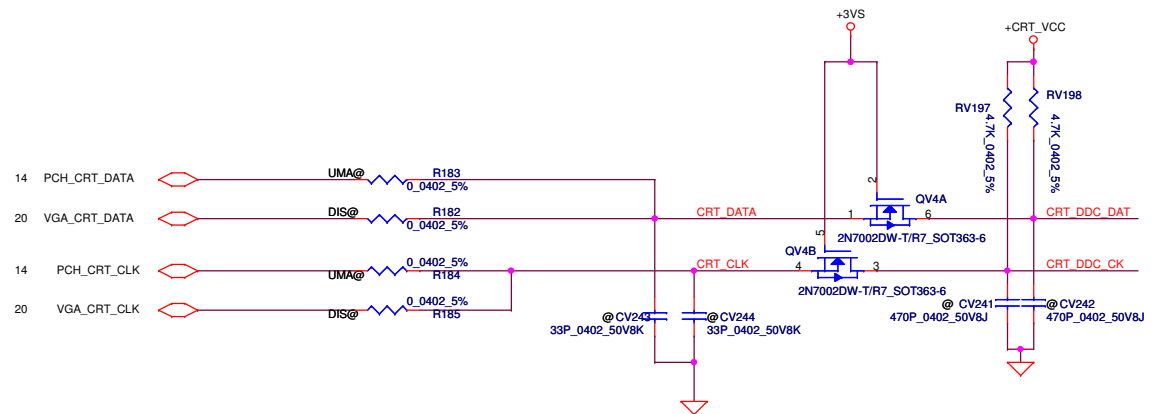
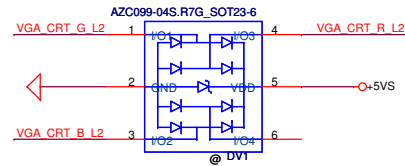
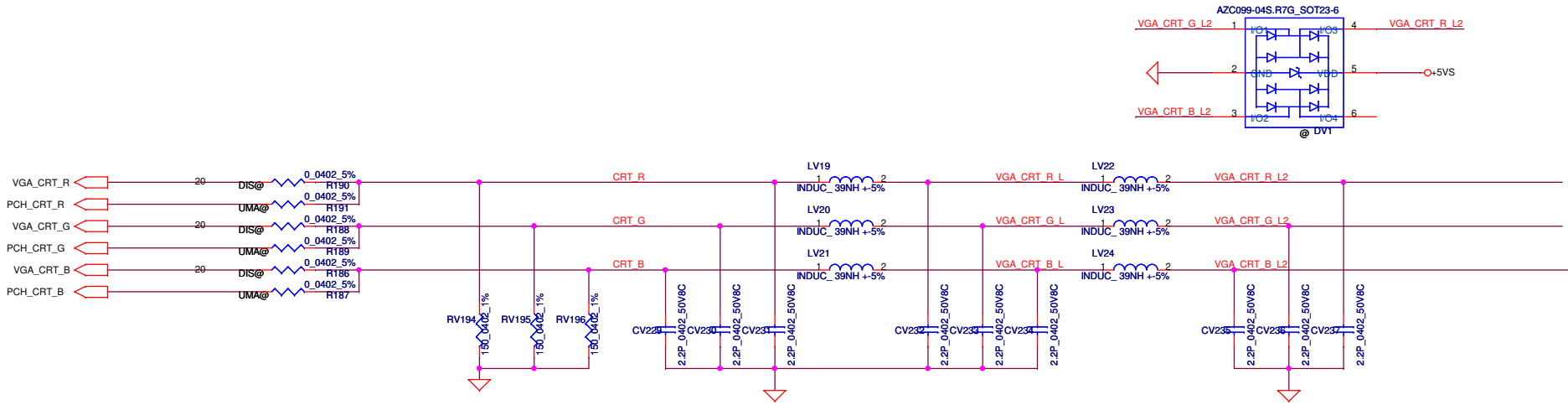

CRT CONNECTOR

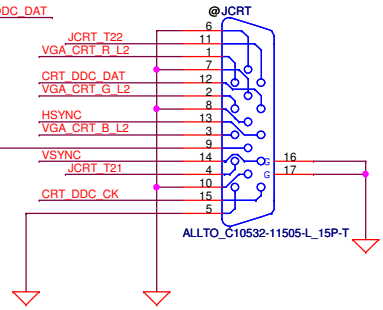

Close to CRT Connector

Security Classification	Compal Secret Data	
Issued Date	2011/05/23	Deciphered Date
		2012/12/31
THIS SHEET OF ENGINEERING DRAWING IS THE PROPRIETARY PROPERTY OF COMPAL ELECTRONICS, INC. AND CONTAINS CONFIDENTIAL AND TRADE SECRET INFORMATION. THIS SHEET MAY NOT BE TRANSFERRED FROM THE CUSTODY OF THE COMPETENT DIVISION OF R&D DEPARTMENT EXCEPT AS AUTHORIZED BY COMPAL ELECTRONICS, INC. NEITHER THIS SHEET NOR THE INFORMATION IT CONTAINS MAY BE USED BY OR DISCLOSED TO ANY THIRD PARTY WITHOUT PRIOR WRITTEN CONSENT OF COMPAL ELECTRONICS, INC.		

Title		
CRT		
Size	Document Number	Rev
	QAL51, LA-7871P MB	1.0
Date:	Wednesday, March 07, 2012	Sheet 30 of 60

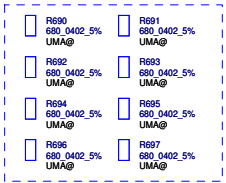
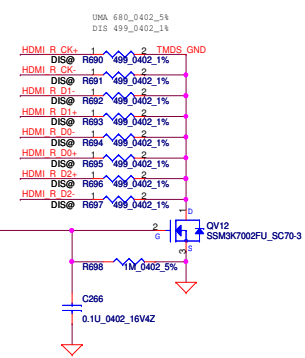
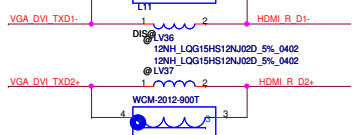
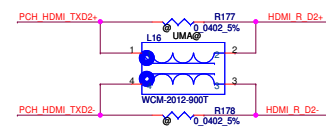
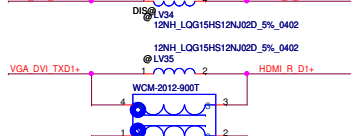
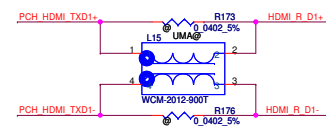
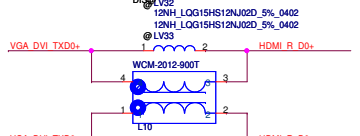
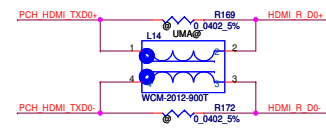
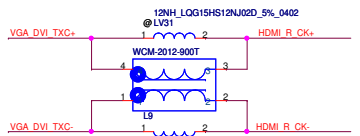
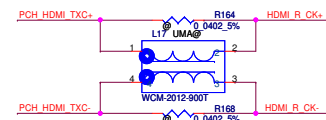
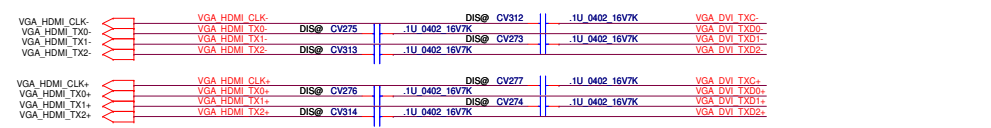
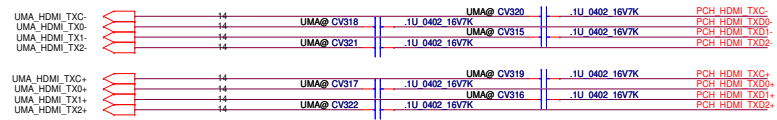
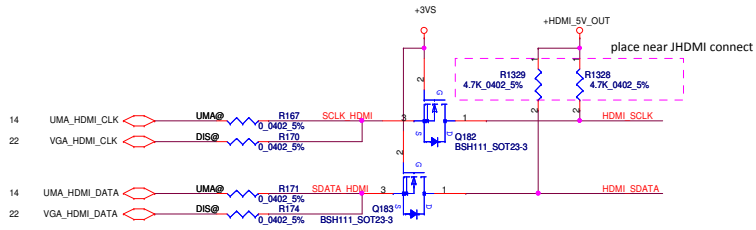
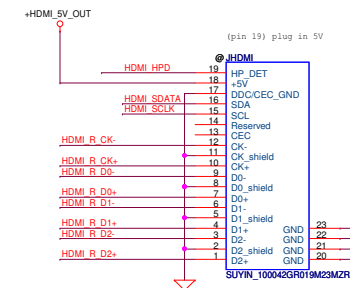
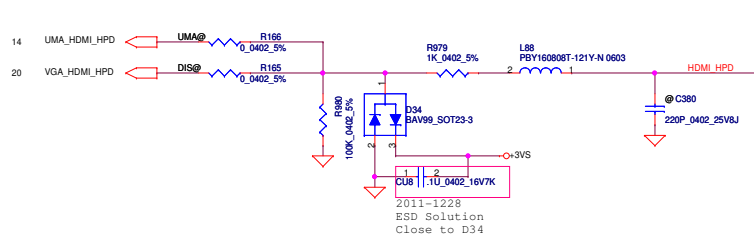
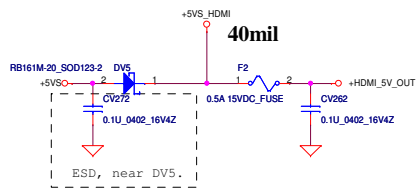

Security Classification	Compal Secret Data		Compal Electronics, Inc.	
Issued Date	2011/05/23	Deciphered Date	2012/12/31	Title
THIS SHEET OF ENGINEERING DRAWING IS THE PROPRIETARY PROPERTY OF COMPAL ELECTRONICS, INC. AND CONTAINS CONFIDENTIAL AND TRADE SECRET INFORMATION. THIS SHEET MAY NOT BE TRANSFERRED FROM THE CUSTODY OF THE COMPETENT DIVISION OF R&D DEPARTMENT EXCEPT AS AUTHORIZED BY COMPAL ELECTRONICS, INC. NEITHER THIS SHEET NOR THE INFORMATION IT CONTAINS MAY BE USED BY OR DISCLOSED TO ANY THIRD PARTY WITHOUT PRIOR WRITTEN CONSENT OF COMPAL ELECTRONICS, INC.				HDMI Connector Document Number QAL51_LA-7871P MB Date: Wednesday, March 07, 2012 Sheet 31 of 60

WLAN/BT combo

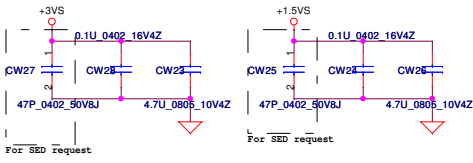
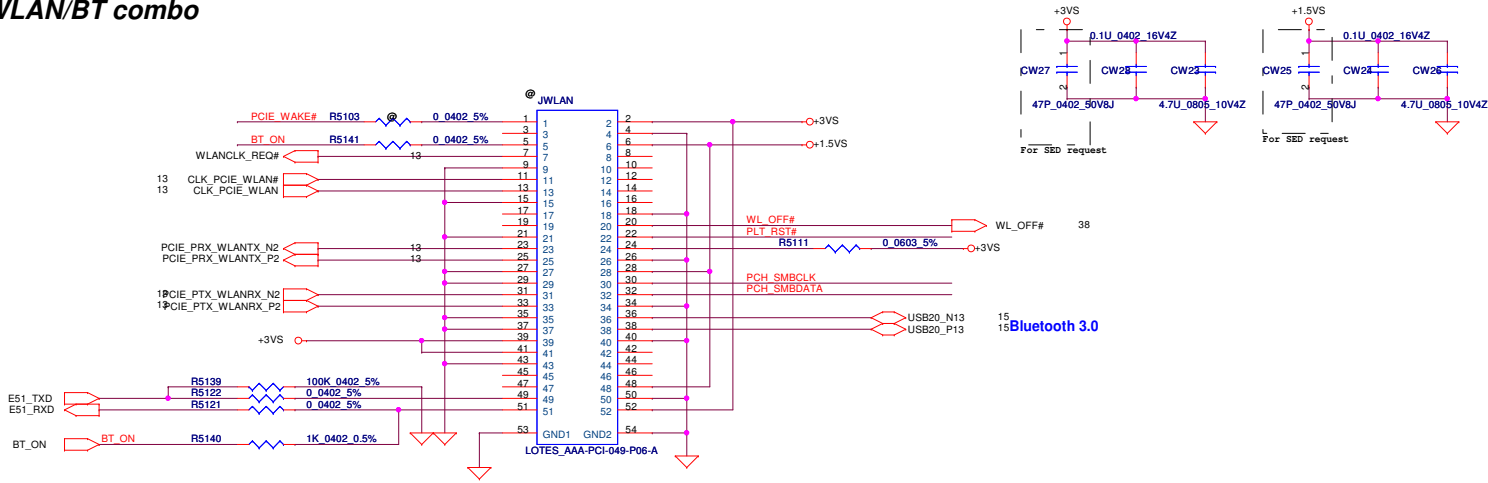

NewCard & Smart Card

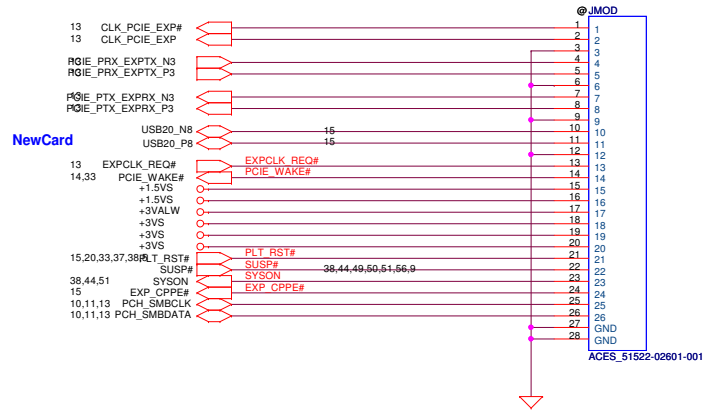

Security Classification		Compal Secret Data		Compal Electronics, Inc.	
Issued Date	2011/05/23	Deciphered Date	2012/12/31	Title	
THIS SHEET OF ENGINEERING DRAWING IS THE PROPRIETARY PROPERTY OF COMPAL ELECTRONICS, INC. AND CONTAINS CONFIDENTIAL AND TRADE SECRET INFORMATION. THIS SHEET MAY NOT BE TRANSFERRED FROM THE CUSTODY OF THE COMPETENT DIVISION OF R&D DEPARTMENT EXCEPT AS AUTHORIZED BY COMPAL ELECTRONICS, INC. NEITHER THIS SHEET NOR THE INFORMATION IT CONTAINS MAY BE USED BY OR DISCLOSED TO ANY THIRD PARTY WITHOUT PRIOR WRITTEN CONSENT OF COMPAL ELECTRONICS, INC.				Size Custom	Document Number
				WLAN/ WWAN/ m-SATA	
				Date:	Wednesday, March 07, 2012
				Sheet	32 of 60
				Rev	1.0
				QALS1, LA-7871P MB	

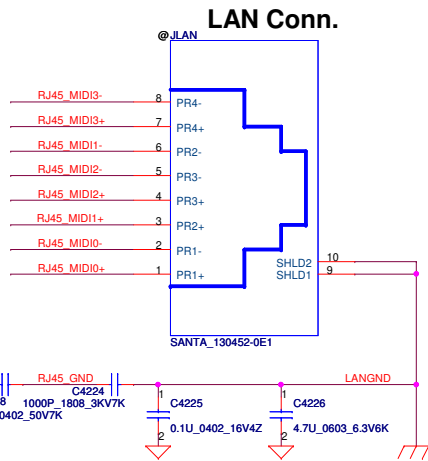
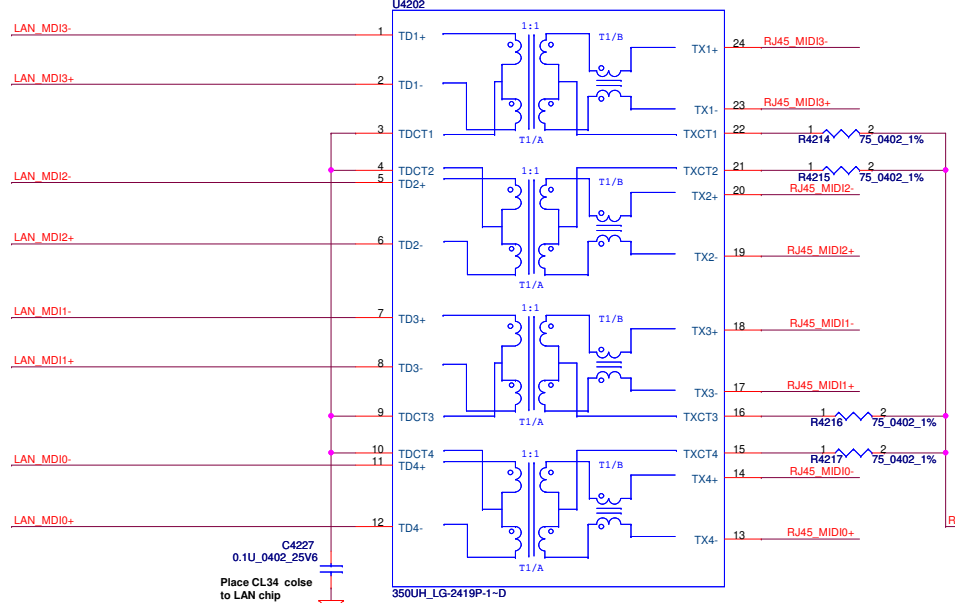
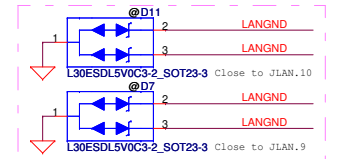
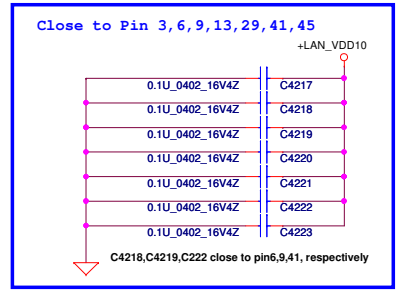
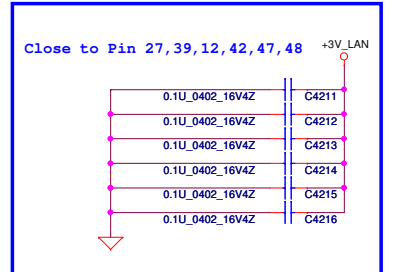
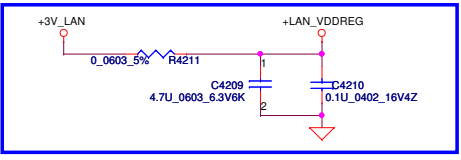
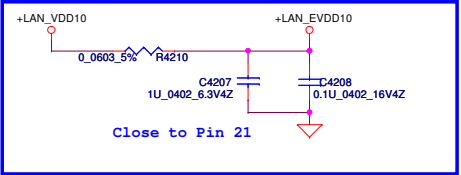
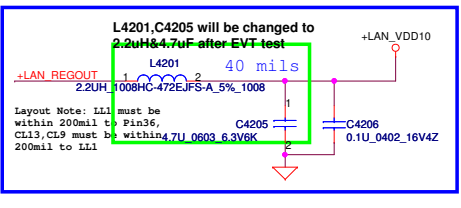
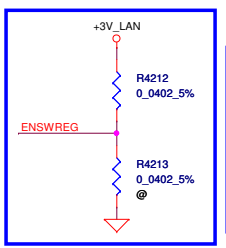
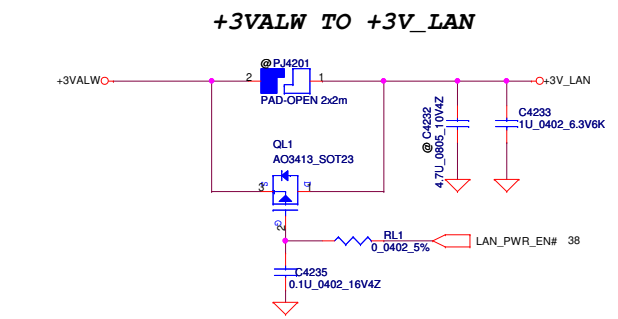
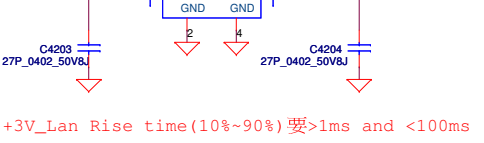
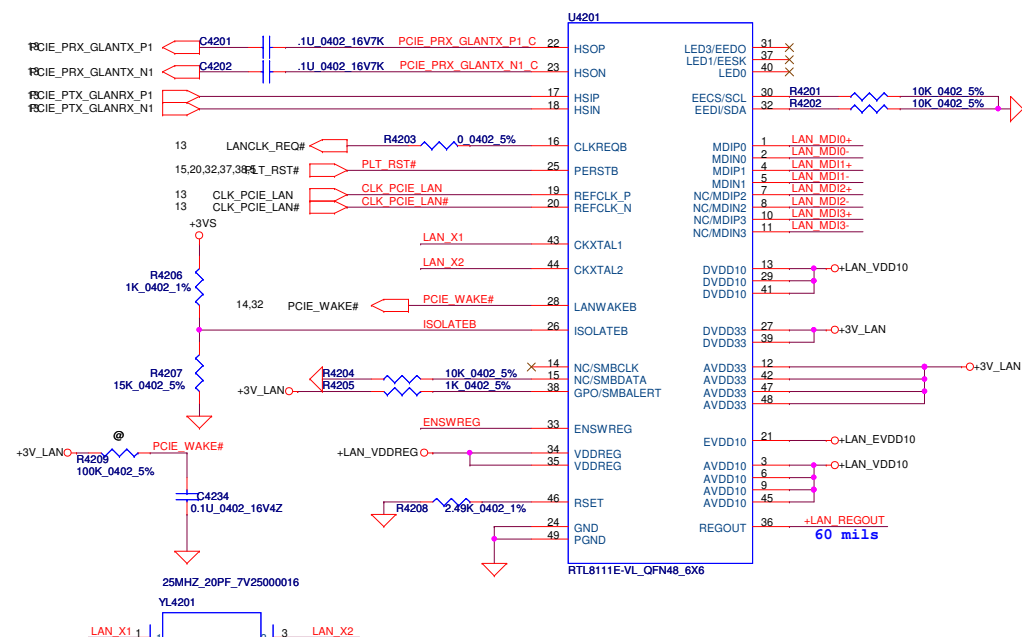

Security Classification		Compal Secret Data		Title	
Issued Date	2011/05/23	Deciphered Date	2012/12/31	PCie-LAN-RTL8111E	
THIS SHEET OF ENGINEERING DRAWING IS THE PROPRIETARY PROPERTY OF COMPAL ELECTRONICS, INC. AND CONTAINS CONFIDENTIAL AND TRADE SECRET INFORMATION. THIS SHEET MAY NOT BE TRANSFERRED FROM THE CUSTODY OF THE COMPETENT DIVISION OF R&D DEPARTMENT EXCEPT AS AUTHORIZED BY COMPAL ELECTRONICS, INC. NEITHER THIS SHEET NOR THE INFORMATION IT CONTAINS MAY BE USED BY OR DISCLOSED TO ANY THIRD PARTY WITHOUT PRIOR WRITTEN CONSENT OF COMPAL ELECTRONICS, INC.					
Size	Document Number	Rev		1.0	
Customer	QAL51, LA-7871P MB	Date:		Wednesday, March 07, 2012	
Date:		Sheet		33 of 60	

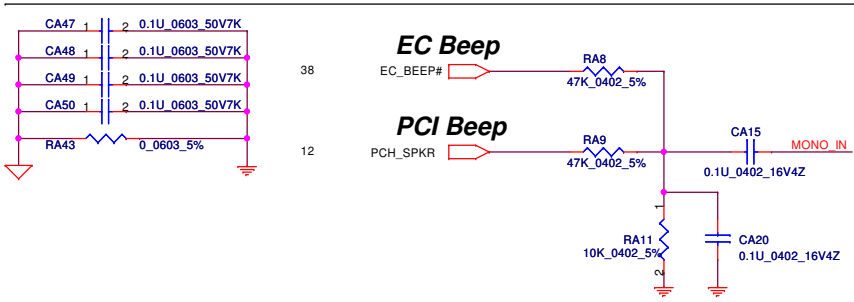
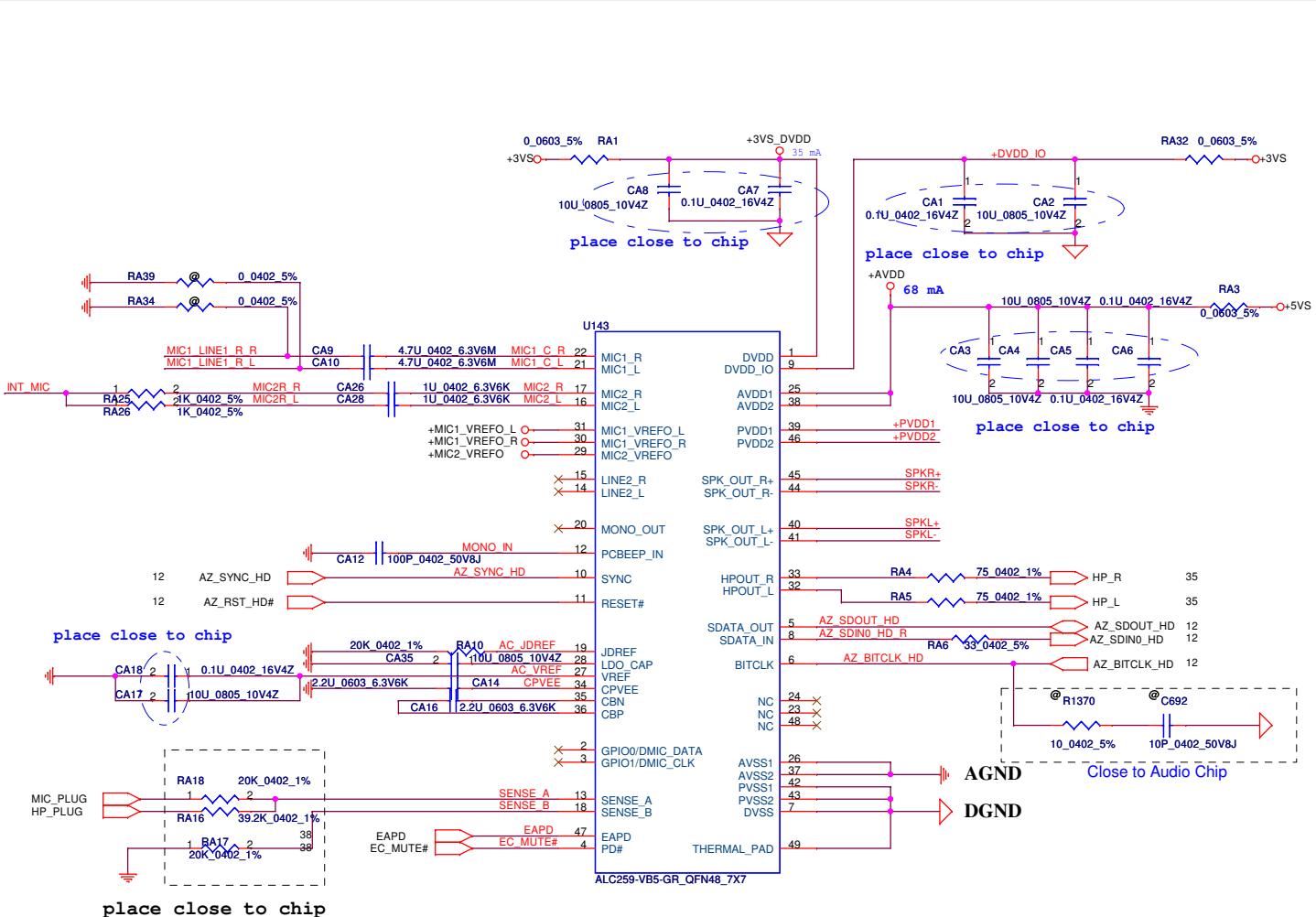

Sense Pin	Impedance	Codec Signals	Function
SENSE A	39.2K	PORT-I (PIN 32, 33)	Headphone out
	20K	PORT-B (PIN 21, 22)	Ext. MIC
SENSE B	20K	PORT-F (PIN 16, 17)	Int. MIC

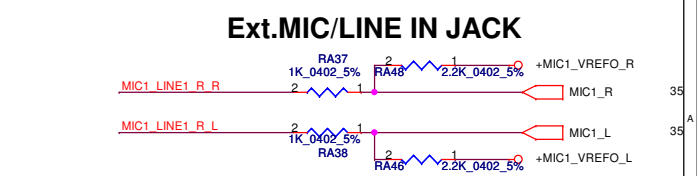
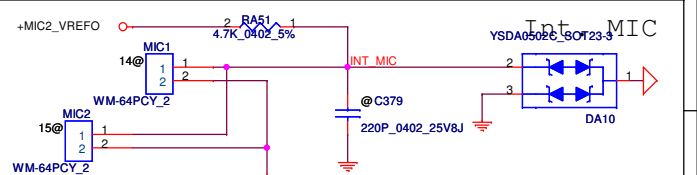
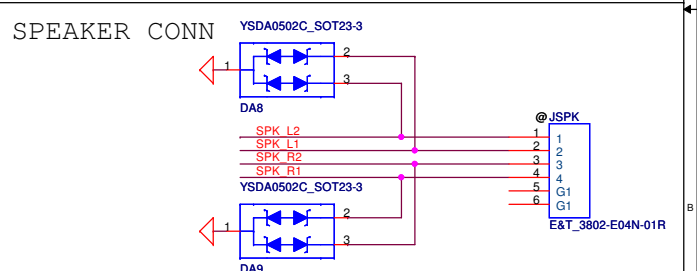
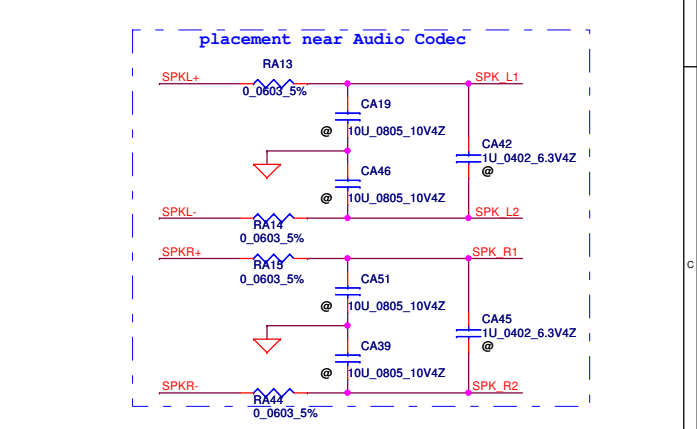
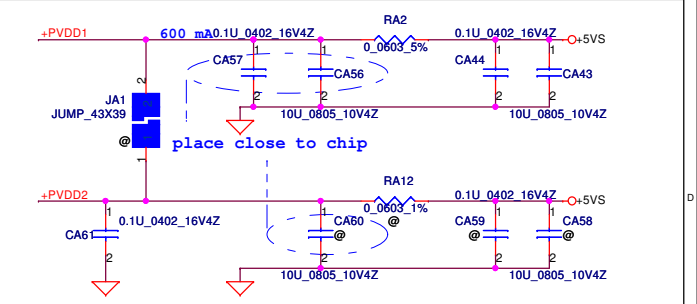

Security Classification		Compal Secret Data		Title	
Issued Date	2011/05/23	Deciphered Date	2012/12/31	HD CODEC ALC259	
THIS SHEET OF ENGINEERING DRAWING IS THE PROPRIETARY PROPERTY OF COMPAL ELECTRONICS, INC. AND CONTAINS CONFIDENTIAL AND TRADE SECRET INFORMATION. THIS SHEET MAY NOT BE TRANSFERRED FROM THE CUSTODY OF THE COMPETENT DIVISION OF R&D DEPARTMENT EXCEPT AS AUTHORIZED BY COMPAL ELECTRONICS, INC. NEITHER THIS SHEET NOR THE INFORMATION IT CONTAINS MAY BE USED BY OR DISCLOSED TO ANY THIRD PARTY WITHOUT PRIOR WRITTEN CONSENT OF COMPAL ELECTRONICS, INC.				Size	Document Number
				QAL51_LA-7871P MB	
				Date:	Wednesday, March 07, 2012
				Sheet	34 of 60

Compal Electronics, Inc.

HD CODEC ALC259

QAL51_LA-7871P MB

Date: Wednesday, March 07, 2012 Sheet 34 of 60

HEADPHONE OUT JACK

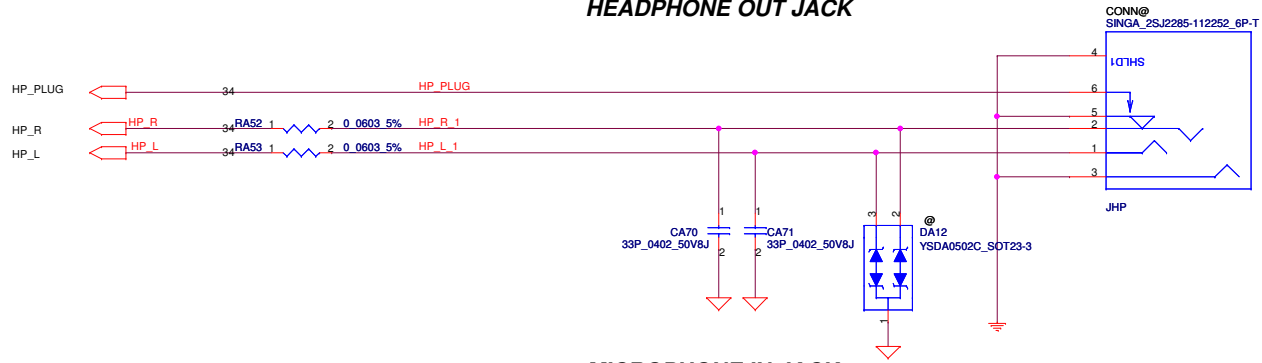

MICROPHONE IN JACK

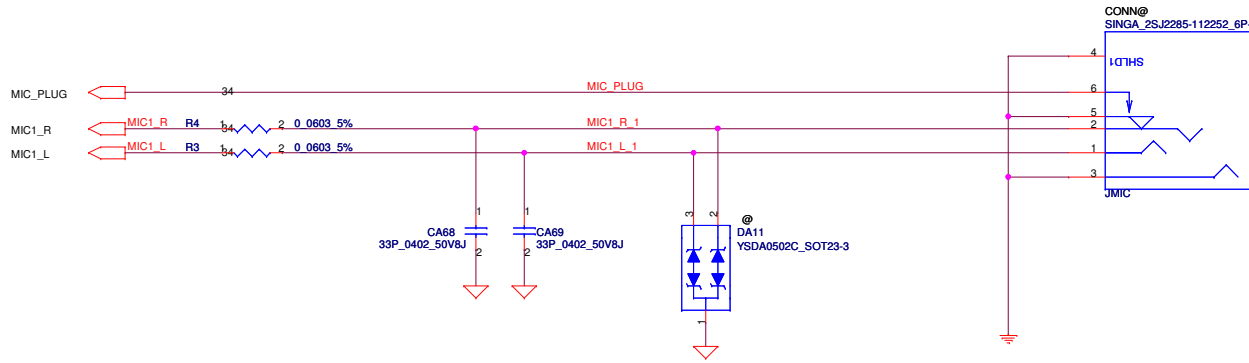

Touch/B Connector

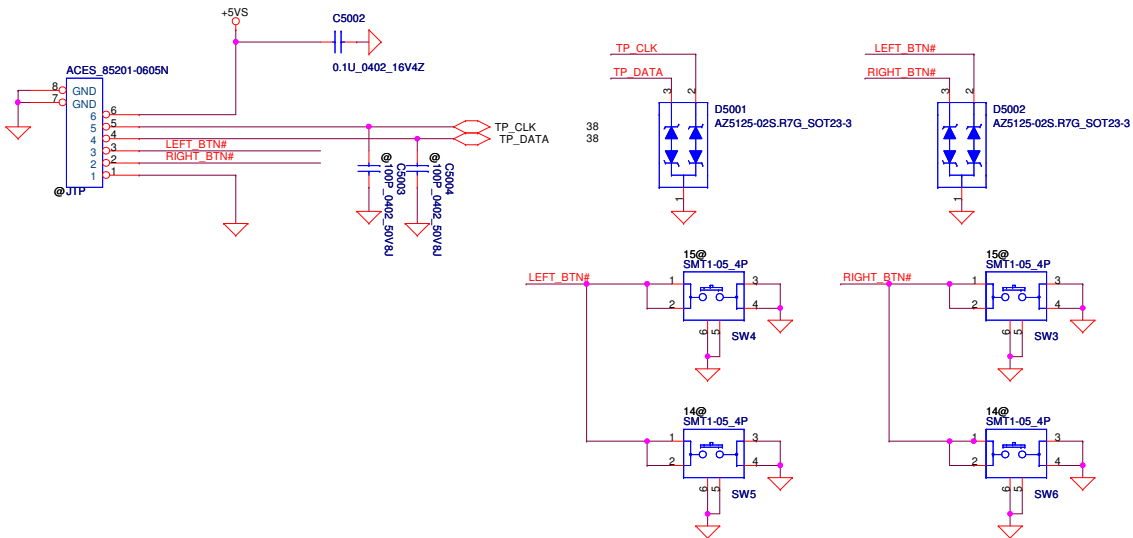

Finger Printer Connector

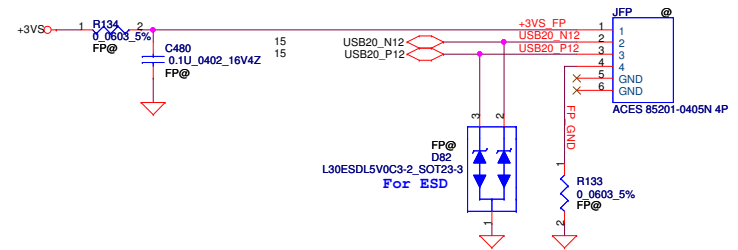

Title			
Card Reader RTSS129			
Size	Document Number	Rev	
	QAL51, LA-7871P MB	1.0	
Date:	Wednesday, March 07, 2012	Sheet	35 of 60

SATA ODD Conn.

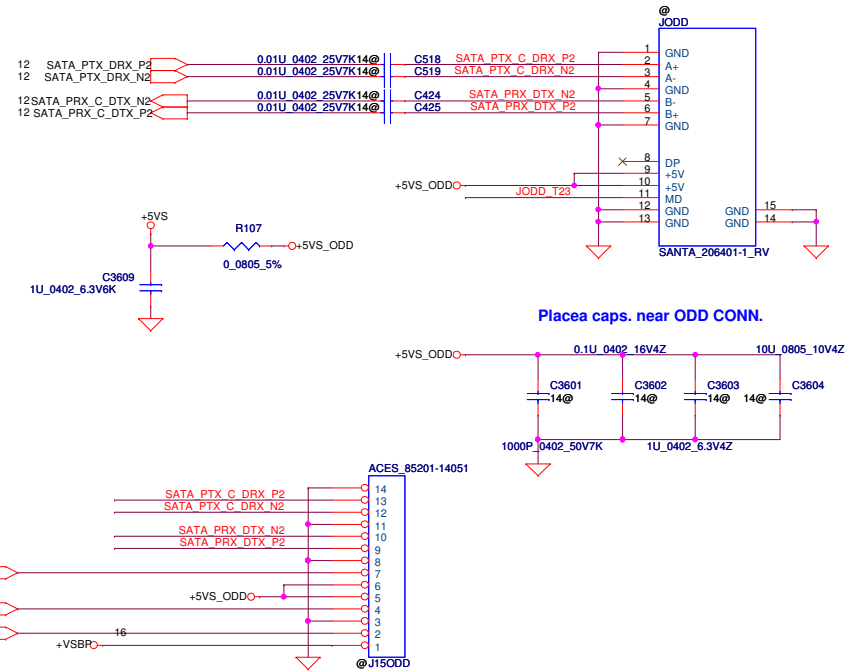

Place caps. near ODD CONN.

SATA HDD Conn.

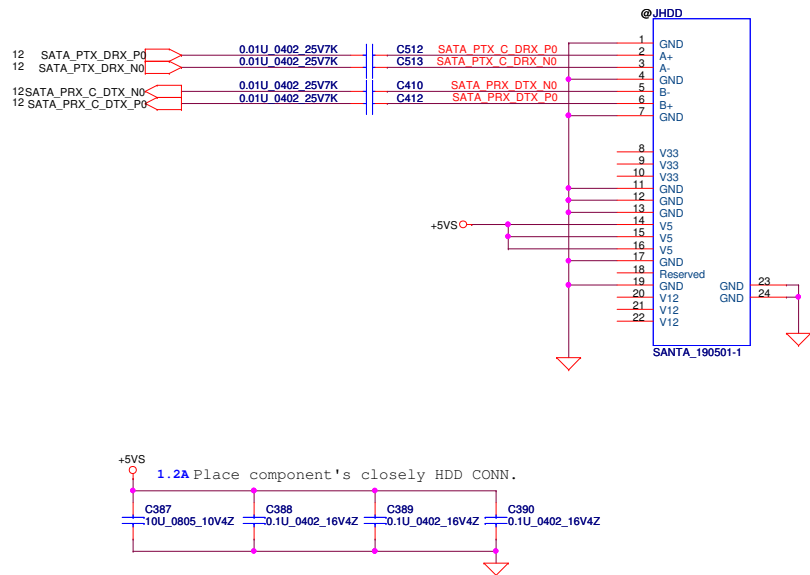

Security Classification		Compal Secret Data		Compal Electronics, Inc.	
Issued Date	2011/05/23	Deciphered Date	2012/12/31	Title	
				SATA HDD / ODD	
THIS SHEET OF ENGINEERING DRAWING IS THE PROPRIETARY PROPERTY OF COMPAL ELECTRONICS, INC. AND CONTAINS CONFIDENTIAL AND TRADE SECRET INFORMATION. THIS SHEET MAY NOT BE TRANSFERRED FROM THE CUSTODY OF THE COMPETENT DIVISION OF R&D DEPARTMENT EXCEPT AS AUTHORIZED BY COMPAL ELECTRONICS, INC. NEITHER THIS SHEET NOR THE INFORMATION IT CONTAINS MAY BE USED BY OR DISCLOSED TO ANY THIRD PARTY WITHOUT PRIOR WRITTEN CONSENT OF COMPAL ELECTRONICS, INC.				Size	Document Number
				Custom	QALS1, LA-7871P MB
				Date	Wednesday, March 07, 2012
				Sheet	36 of 60
				Rev	1.0

SPI ROM For Basic ME ROM size
(w/o Braidwood & system BIOS):
4MByte

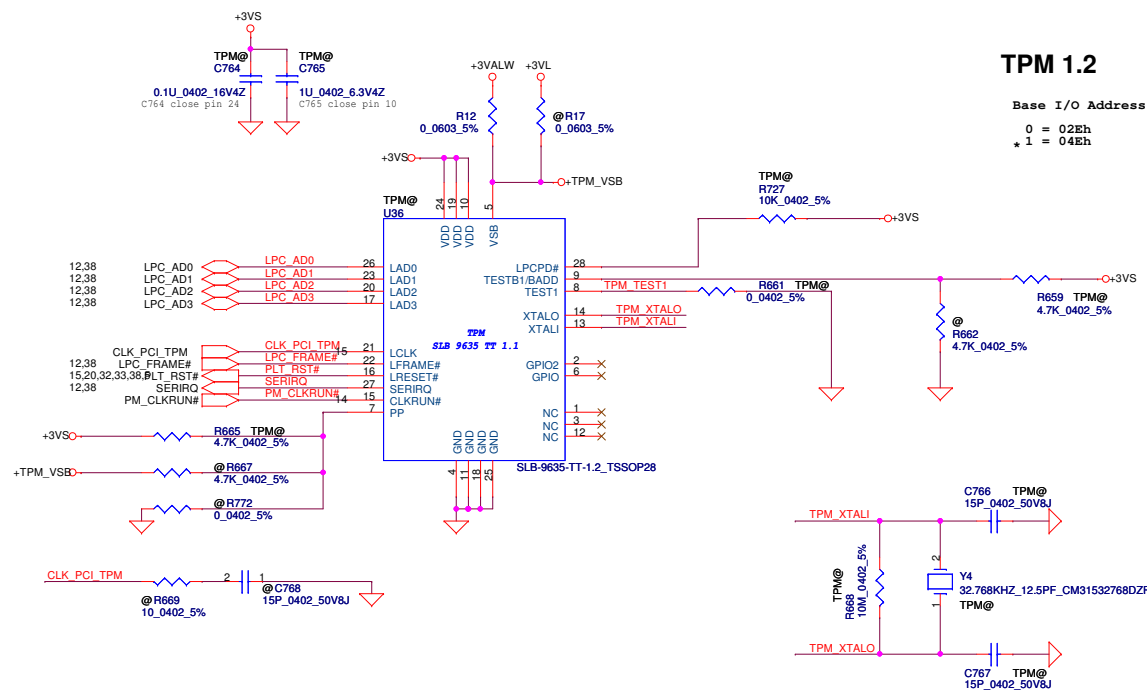

TPM 1.2
Base I/O Address
0 = 02Eh
1 = 04Eh

Security Classification		Compal Secret Data		Title	
Issued Date	2011/05/23	Deciphered Date	2012/12/31	TPM	
THIS SHEET OF ENGINEERING DRAWING IS THE PROPRIETARY PROPERTY OF COMPAL ELECTRONICS, INC. AND CONTAINS CONFIDENTIAL AND TRADE SECRET INFORMATION. THIS SHEET MAY NOT BE TRANSFERRED FROM THE CUSTODY OF THE COMPETENT DIVISION OF R&D DEPARTMENT EXCEPT AS AUTHORIZED BY COMPAL ELECTRONICS, INC. NEITHER THIS SHEET NOR THE INFORMATION IT CONTAINS MAY BE USED BY OR DISCLOSED TO ANY THIRD PARTY WITHOUT PRIOR WRITTEN CONSENT OF COMPAL ELECTRONICS, INC.				Size	Document Number
				Date	Wednesday, March 07, 2012
				Rev	
				1.0	
				QAL51, LA-7871P MB	

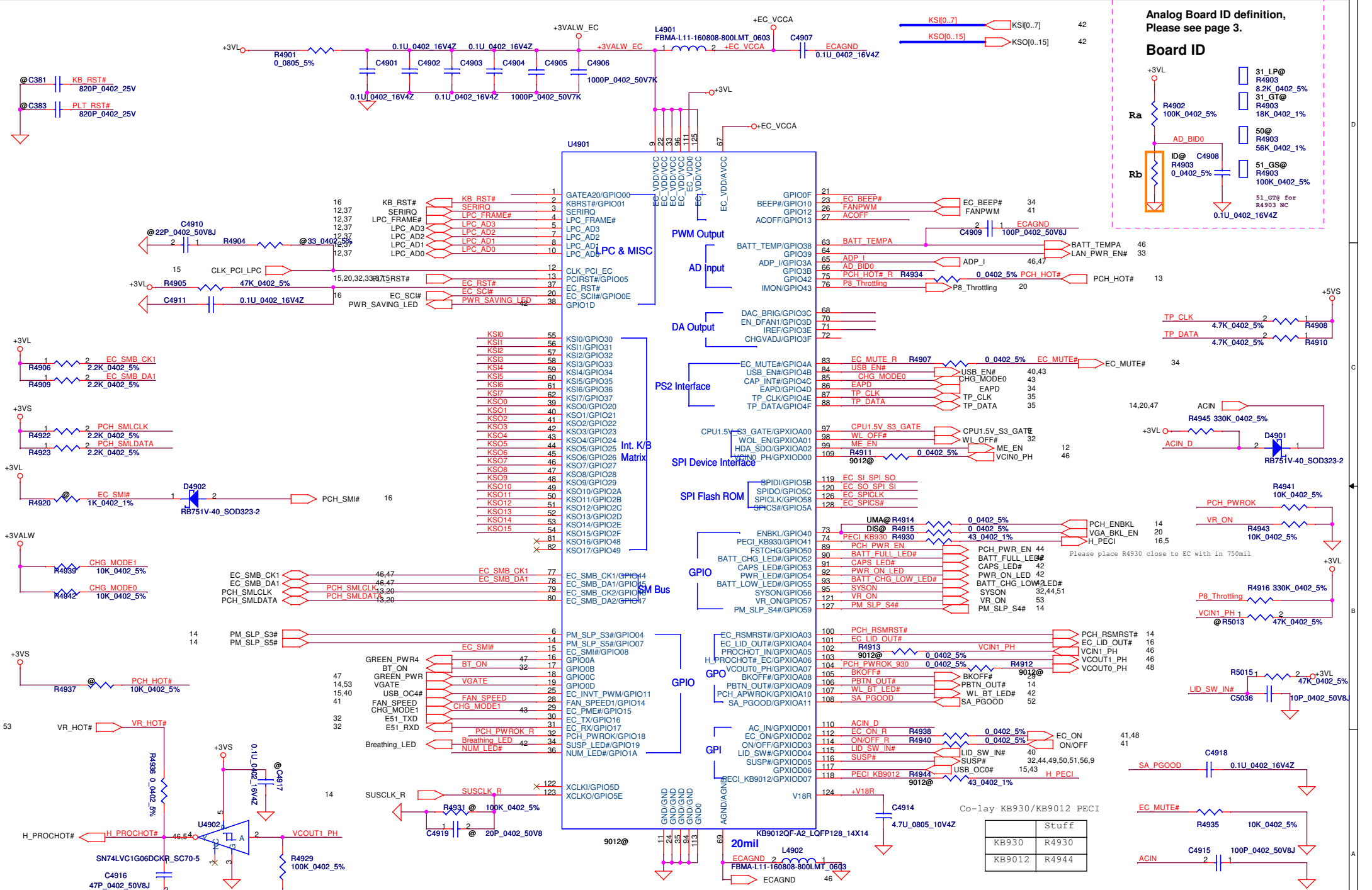

Analogue Board ID definition, Please see page 3.

Board ID

- 31_LP@ R4903
- 8.2K_0402_5% R4903
- 31_GT@ R4903
- 18K_0402_1% R4903
- 50@ R4903
- 56K_0402_1% R4903
- 51_GS@ R4903
- 100K_0402_5% R4903
- 51_G78 for R4903 NC

Security Classification		Compal Secret Data	
Issued Date	2011/05/23	Deciphered Date	2012/12/31

THIS SHEET OF ENGINEERING DRAWING IS THE PROPRIETARY PROPERTY OF COMPAL ELECTRONICS, INC. AND CONTAINS CONFIDENTIAL AND TRADE SECRET INFORMATION. THIS SHEET MAY NOT BE TRANSFERRED FROM THE CUSTODY OF THE COMPETENT DIVISION OF R&D DEPARTMENT EXCEPT AS AUTHORIZED BY COMPAL ELECTRONICS, INC. NEITHER THIS SHEET NOR THE INFORMATION IT CONTAINS MAY BE USED BY OR DISCLOSED TO ANY THIRD PARTY WITHOUT PRIOR WRITTEN CONSENT OF COMPAL ELECTRONICS, INC.

Compal Electronics, Inc.

EC ENE-KB930/Co-lay 9012

Size B	Document Number	Rev 1.0
Date:	Wednesday, March 07, 2012	Sheet 38 of 60

BIOS Bus switch
SPI ROM For Basic ME ROM size
4MByte

BIOS SPI Flash (4MByte*1)

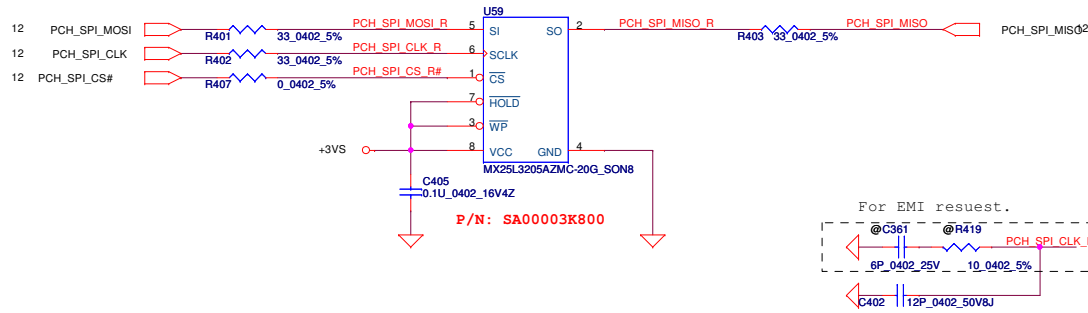

BIOS SPI Flash (2MByte*1) For Win8

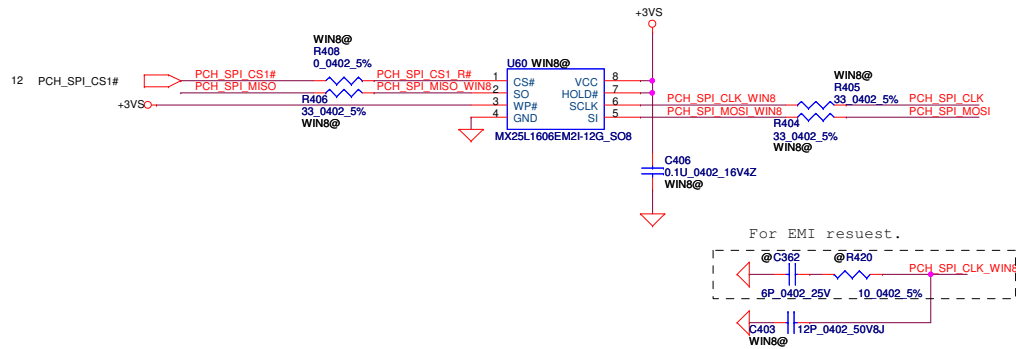

Security Classification	Compal Secret Data			Compal Electronics, Inc. SBIOS & EC ROM		
Issued Date	2011/05/23	Deciphered Date	2012/12/31			
<small>THIS SHEET OF ENGINEERING DRAWING IS THE PROPRIETARY PROPERTY OF COMPAL ELECTRONICS, INC. AND CONTAINS CONFIDENTIAL AND TRADE SECRET INFORMATION. THIS SHEET MAY NOT BE TRANSFERRED FROM THE CUSTODY OF THE COMPETENT DIVISION OF R&D DEPARTMENT EXCEPT AS AUTHORIZED BY COMPAL ELECTRONICS, INC. NEITHER THIS SHEET NOR THE INFORMATION IT CONTAINS MAY BE USED BY OR DISCLOSED TO ANY THIRD PARTY WITHOUT PRIOR WRITTEN CONSENT OF COMPAL ELECTRONICS, INC.</small>				Size	Document Number	Rev
				Date:	Wednesday, March 07, 2012	Sheet 39 of 60

USB + Audio SB

HeadPhone/LINE Out JACK

Ext.MIC/LINE IN JACK

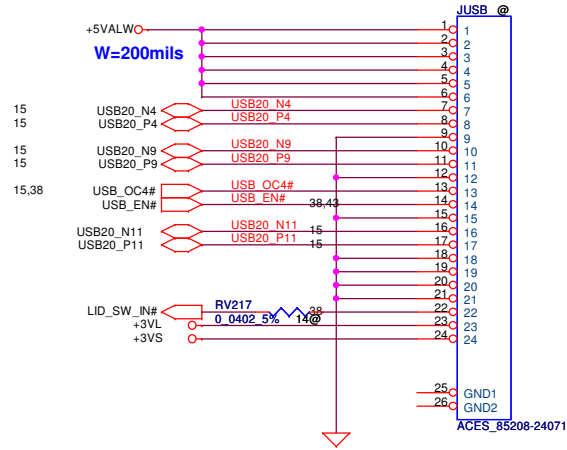

Lid Switch

(Hall Effect Switch)

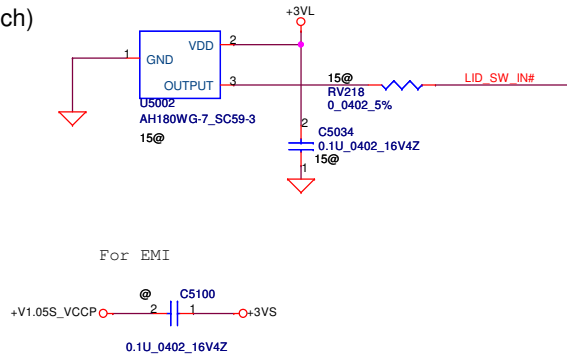

Security Classification		Compal Secret Data		Compal Electronics, Inc.	
Issued Date	2011/05/23	Deciphered Date	2012/12/31	Title Function Board	
THIS SHEET OF ENGINEERING DRAWING IS THE PROPRIETARY PROPERTY OF COMPAL ELECTRONICS, INC. AND CONTAINS CONFIDENTIAL AND TRADE SECRET INFORMATION. THIS SHEET MAY NOT BE TRANSFERRED FROM THE CUSTODY OF THE COMPETENT DIVISION OF R&D DEPARTMENT EXCEPT AS AUTHORIZED BY COMPAL ELECTRONICS, INC. NEITHER THIS SHEET NOR THE INFORMATION IT CONTAINS MAY BE USED BY OR DISCLOSED TO ANY THIRD PARTY WITHOUT PRIOR WRITTEN CONSENT OF COMPAL ELECTRONICS, INC.				Size	Document Number
				QAL51, LA-7871P MB	
Date: Wednesday, March 07, 2012		Sheet 40 of 60			

LED

SATA

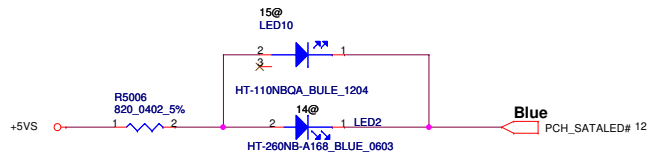

Battery

14" Battery LED 要換料號

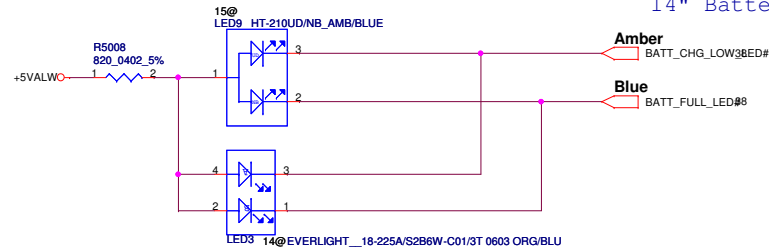

Wireless

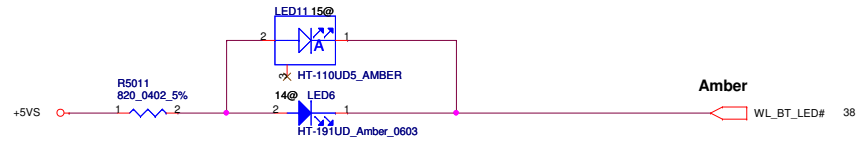

Power

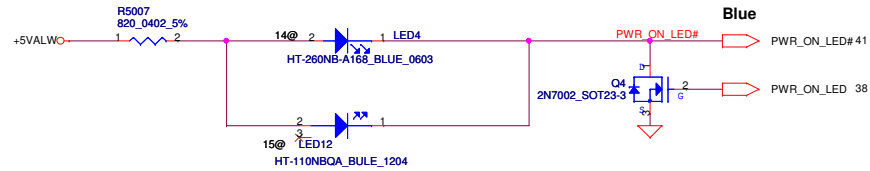

INT_KBD Conn.



CAP Lock

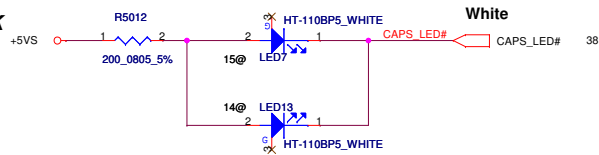

Breathing

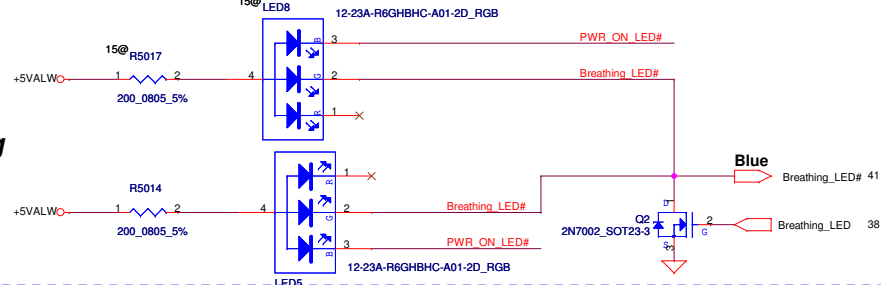

Power Saving

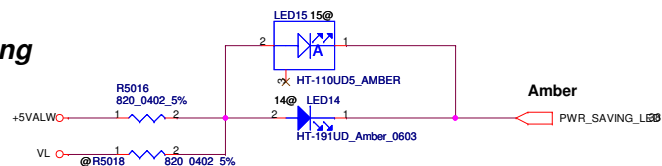

Security Classification	Compal Secret Data 1		Compal Electronics, Inc.	
Issued Date	2011/05/23	Deciphered Date	2012/12/31	Title
THIS SHEET OF ENGINEERING DRAWING IS THE PROPRIETARY PROPERTY OF COMPAL ELECTRONICS, INC. AND CONTAINS CONFIDENTIAL AND TRADE SECRET INFORMATION. THIS SHEET MAY NOT BE TRANSFERRED FROM THE CUSTODY OF THE COMPETENT DIVISION OF R&D DEPARTMENT EXCEPT AS AUTHORIZED BY COMPAL ELECTRONICS, INC. NEITHER THIS SHEET NOR THE INFORMATION IT CONTAINS MAY BE USED BY OR DISCLOSED TO ANY THIRD PARTY WITHOUT PRIOR WRITTEN CONSENT OF COMPAL ELECTRONICS, INC.				KB/EC ROM/TP/FUN/LED
Size	Document Number		Rev	1.0
B	QAL51, LA-7871P MB		Date:	Wednesday, March 07, 2012
			Sheet	42 of 60

USB3.0 Port 0

USB3.0 Port0
Port 0 : Left USB3.0

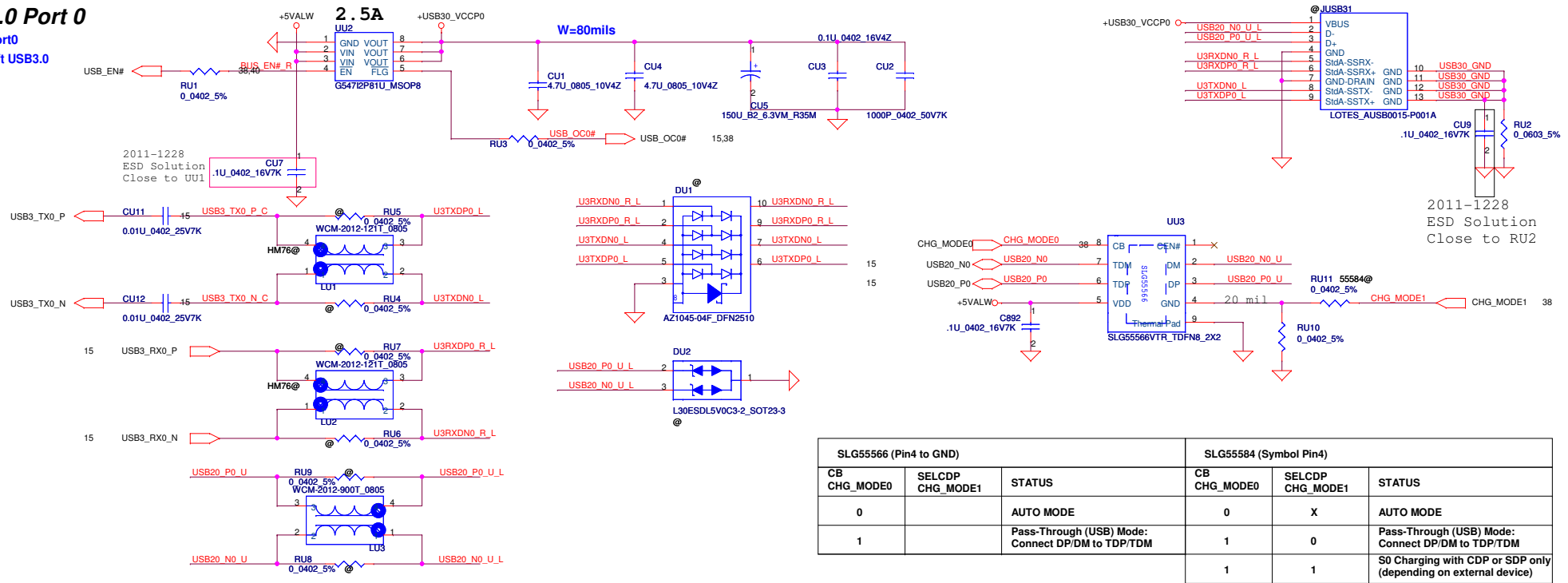

USB3.0 Port 1

USB3.0 Port1
Port 1 : Left USB3.0 with e-SATA

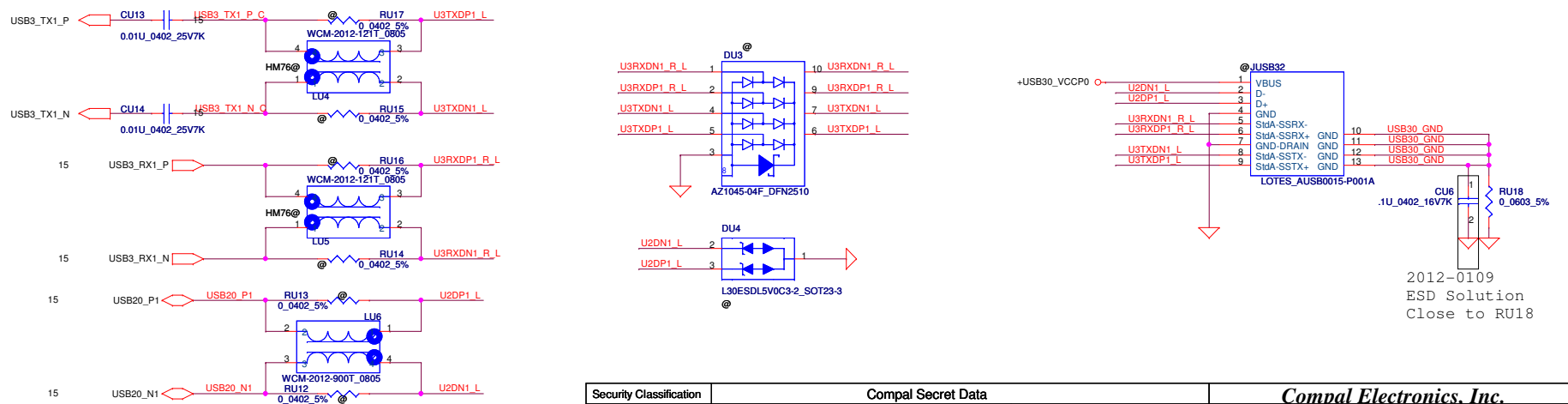

Security Classification	Compal Secret Data			Compal Electronics, Inc.	
Issued Date	2011/05/23	Deciphered Date	2012/12/31	Title	Power share ENE3810
THIS SHEET OF ENGINEERING DRAWING IS THE PROPRIETARY PROPERTY OF COMPAL ELECTRONICS, INC. AND CONTAINS CONFIDENTIAL AND TRADE SECRET INFORMATION. THIS SHEET MAY NOT BE TRANSFERRED FROM THE CUSTODY OF THE COMPETENT DIVISION OF R&D DEPARTMENT EXCEPT AS AUTHORIZED BY COMPAL ELECTRONICS, INC. NEITHER THIS SHEET NOR THE INFORMATION IT CONTAINS MAY BE USED BY OR DISCLOSED TO ANY THIRD PARTY WITHOUT PRIOR WRITTEN CONSENT OF COMPAL ELECTRONICS, INC.				Size	Document Number
				Custom	QALS1_LA-781P MB
				Date	Wednesday, March 07, 2012
				Sheet	43 of 60
				Rev	1.0

+5VALW to +5VS

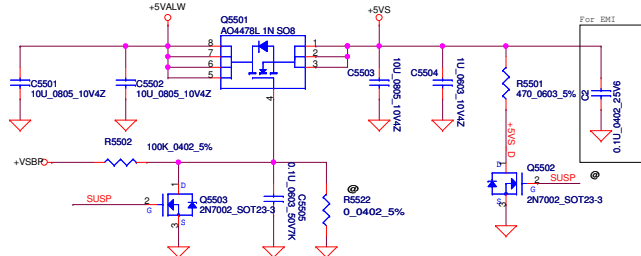

+1.5V to +VRAM_1.5VS

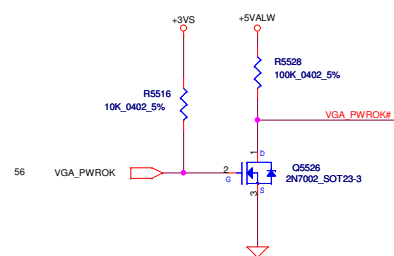
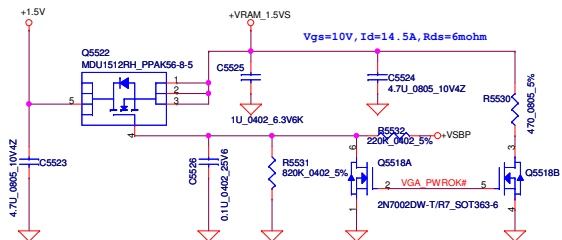

+3VALW to +3VS

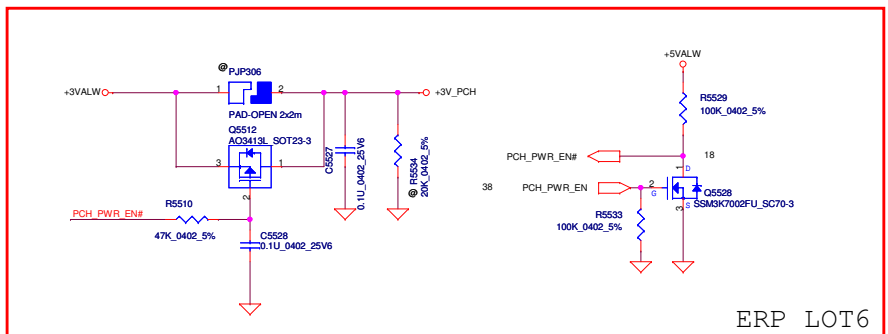
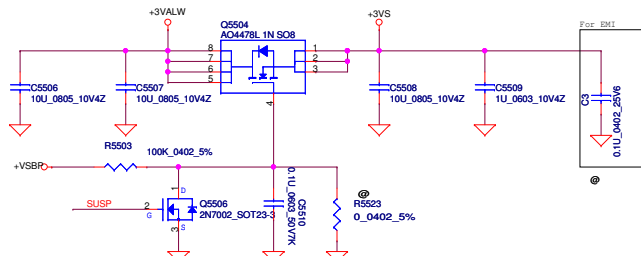

ERP LOT6

+1.5V To +1.5VS

CHECK WITH CPU memory power

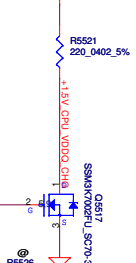
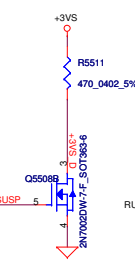
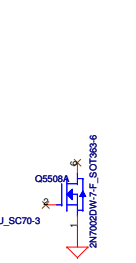
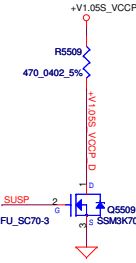
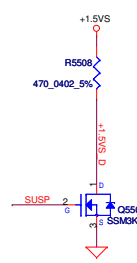
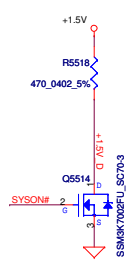
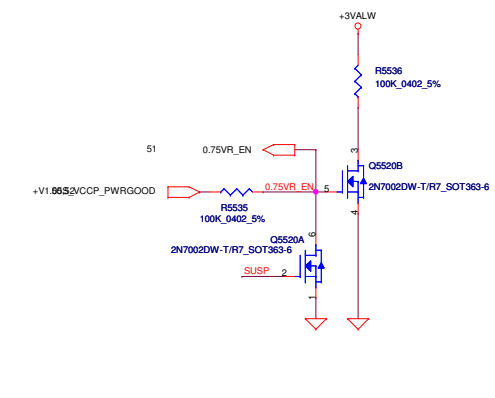
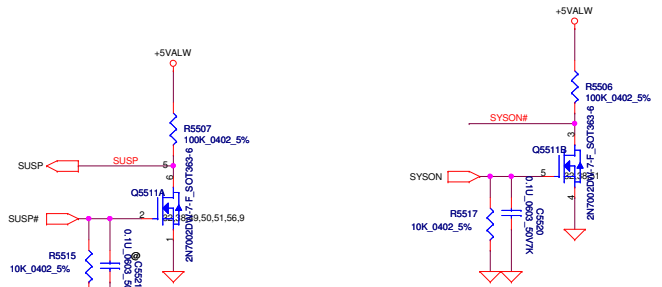
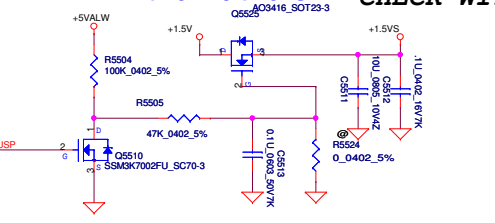

Security Classification	Compal Secret Data	
Issued Date	2011/05/23	Deciphered Date
		2012/12/31
THIS SHEET OF ENGINEERING DRAWING IS THE PROPRIETARY PROPERTY OF COMPAL ELECTRONICS, INC. AND CONTAINS CONFIDENTIAL AND TRADE SECRET INFORMATION. THIS SHEET MAY NOT BE TRANSFERRED FROM THE CUSTODY OF THE COMPETENT DIVISION OF RAD DEPARTMENT EXCEPT AS AUTHORIZED BY COMPAL ELECTRONICS, INC. NEITHER THIS SHEET NOR THE INFORMATION IT CONTAINS MAY BE USED BY OR DISCLOSED TO ANY THIRD PARTY WITHOUT PRIOR WRITTEN CONSENT OF COMPAL ELECTRONICS, INC.		

Compal Electronics, Inc.	
Title DC/DC Interface	
Size	Document Number
Custom	QAL51_LA-7871P MB
Date	Wednesday, March 07, 2012
Sheet	44 of 60
Rev	1.0

www.s-manuals.com