

TPC02 MLB

PAGE 01 : COVER PAGE
PAGE 02 : SYSTEM BLOCK DIAGRAM
PAGE 03 : CPU-1
PAGE 04 : CPU-2
PAGE 05 : NB-1
PAGE 06 : NB-2
PAGE 07 : NB-3
PAGE 08 : SB-1
PAGE 09 : SB-2
PAGE 10 : SB-3
PAGE 11 : CLOCK
PAGE 12 : DDR SODIMM
PAGE 13 : DDR_TERMINATOR & VTT CAP
PAGE 14 : CB-1410 CONTROLLER
PAGE 15 : MINI PCI & PCMCIA CONN.
PAGE 16 : 1394a
PAGE 17 : LAN
PAGE 18 : LPC
PAGE 19 : KBC/EC PC87591
PAGE 20 : LVDS & INVERTER CONN.
PAGE 21 : TV ENCODER
PAGE 22 : CRT CONN & FAN CONN
PAGE 23 : Audio Codec, MIC
PAGE 24 : AUDIO SPRK, MDC
PAGE 25 : HDD & CDROM CONN.
PAGE 26 : PRT , POWERGD , RESET SW
PAGE 27 : USB PORT & LEDs
PAGE 28 : RTC & SUSPEND POWER
PAGE 29 : DCIN & CHARGER
PAGE 30 : SYSTEM POWER I(MAX1999)
PAGE 31 : SYSTEM POWER II&DDR1V25
PAGE 32 : VCORE & CPU1V5
PAGE 33 : HISTORY

www.hocnghetructuyen.vn

www.hocnghetructuyen.vn

www.hocnghetructuyen.vn

www.hocnghetructuyen.vn

	
Title	Cover Page
Document Number	<i>TPC02-A-0.0</i>
Date: Sunday, February 01, 2004	Sheet 1 of 33
	Rev A

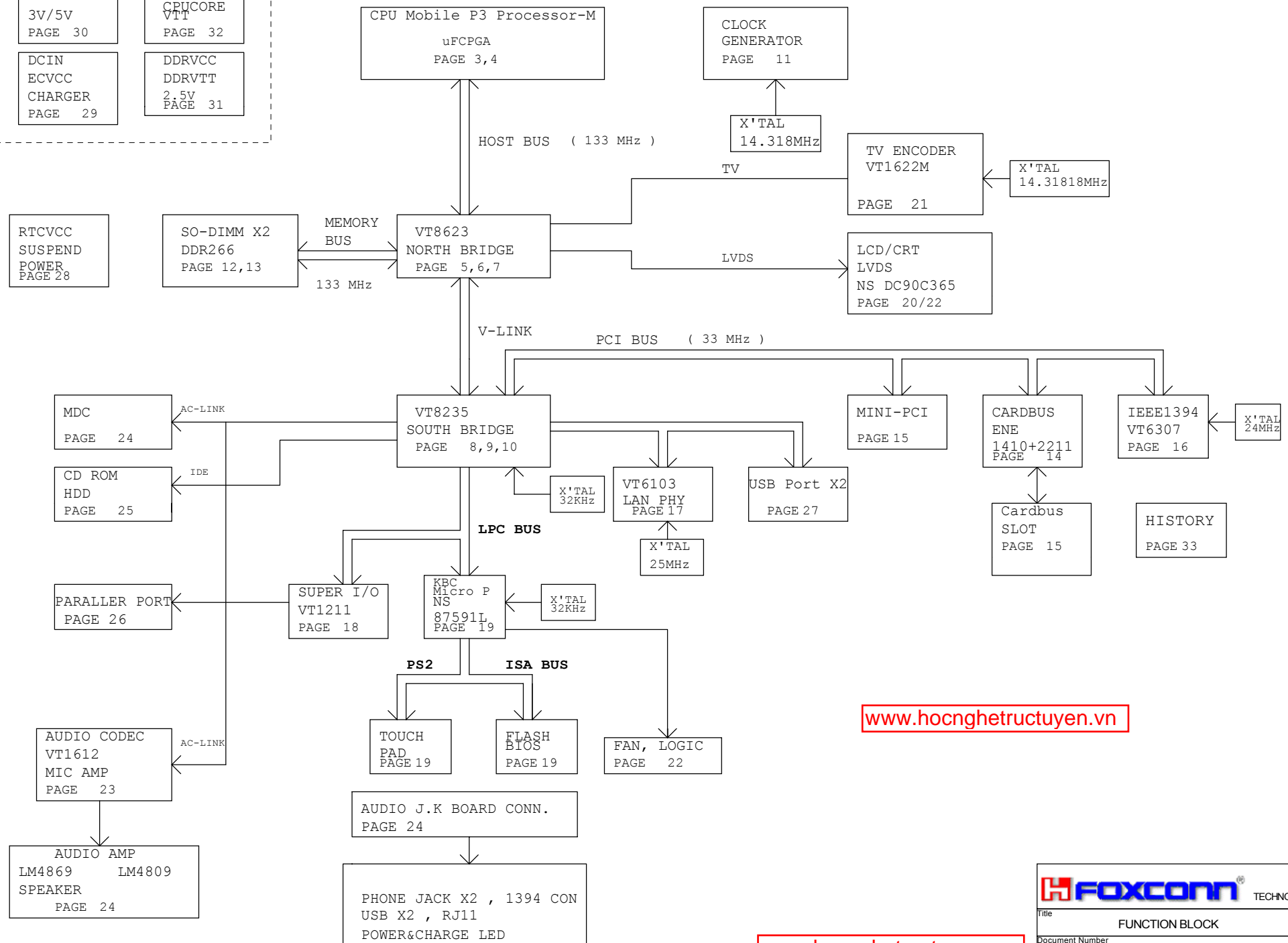
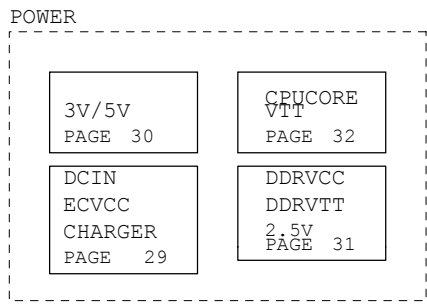

www.hocnghetructuyen.vn

www.hocnghetructuyen.vn

FOXCONN TECHNOLOGY CORP.

Title: **FUNCTION BLOCK**

Document Number: **TPC02-A-0.0**

Date: Sunday, February 01, 2004

Sheet 2 of 33

Rev: **A**

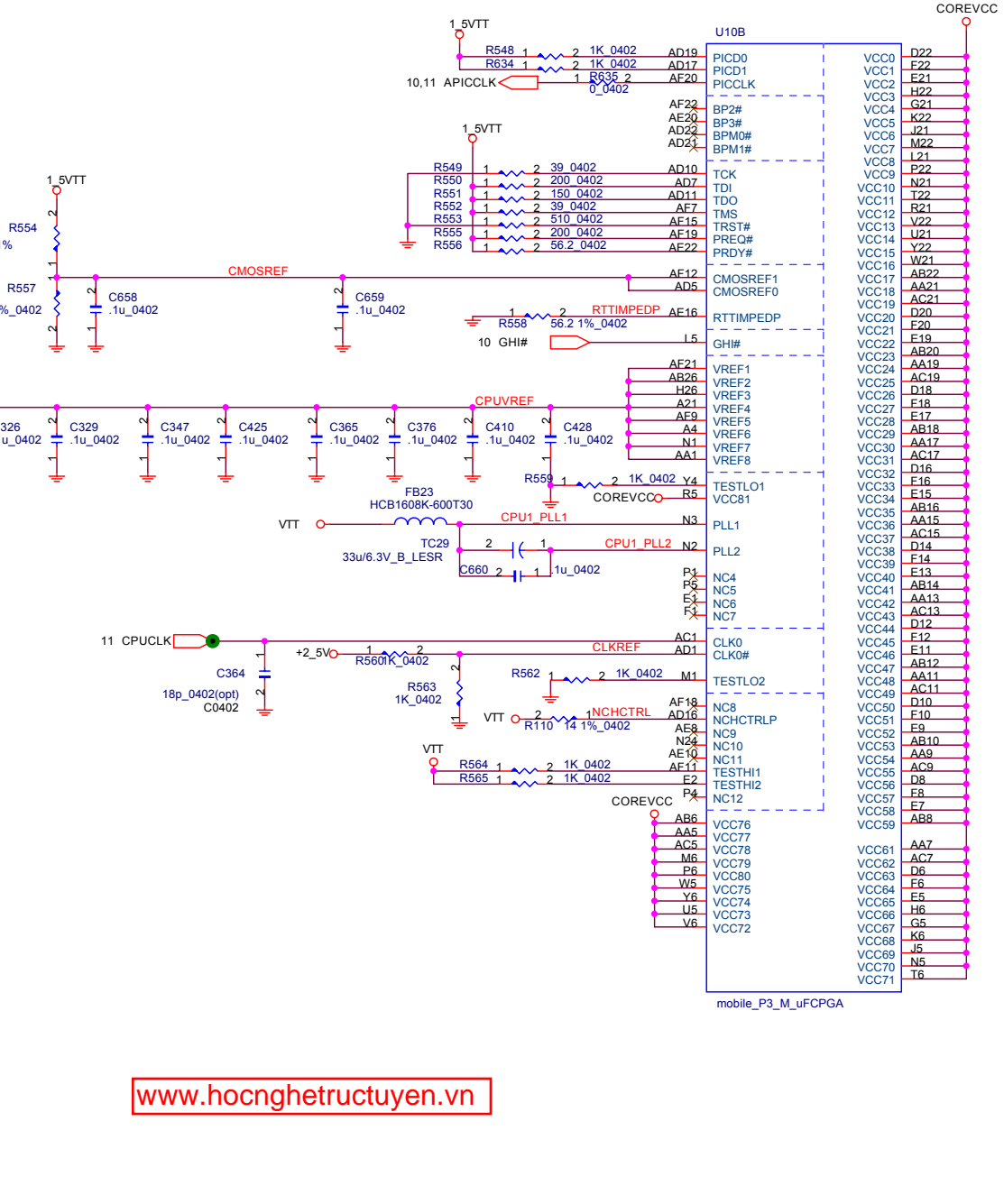
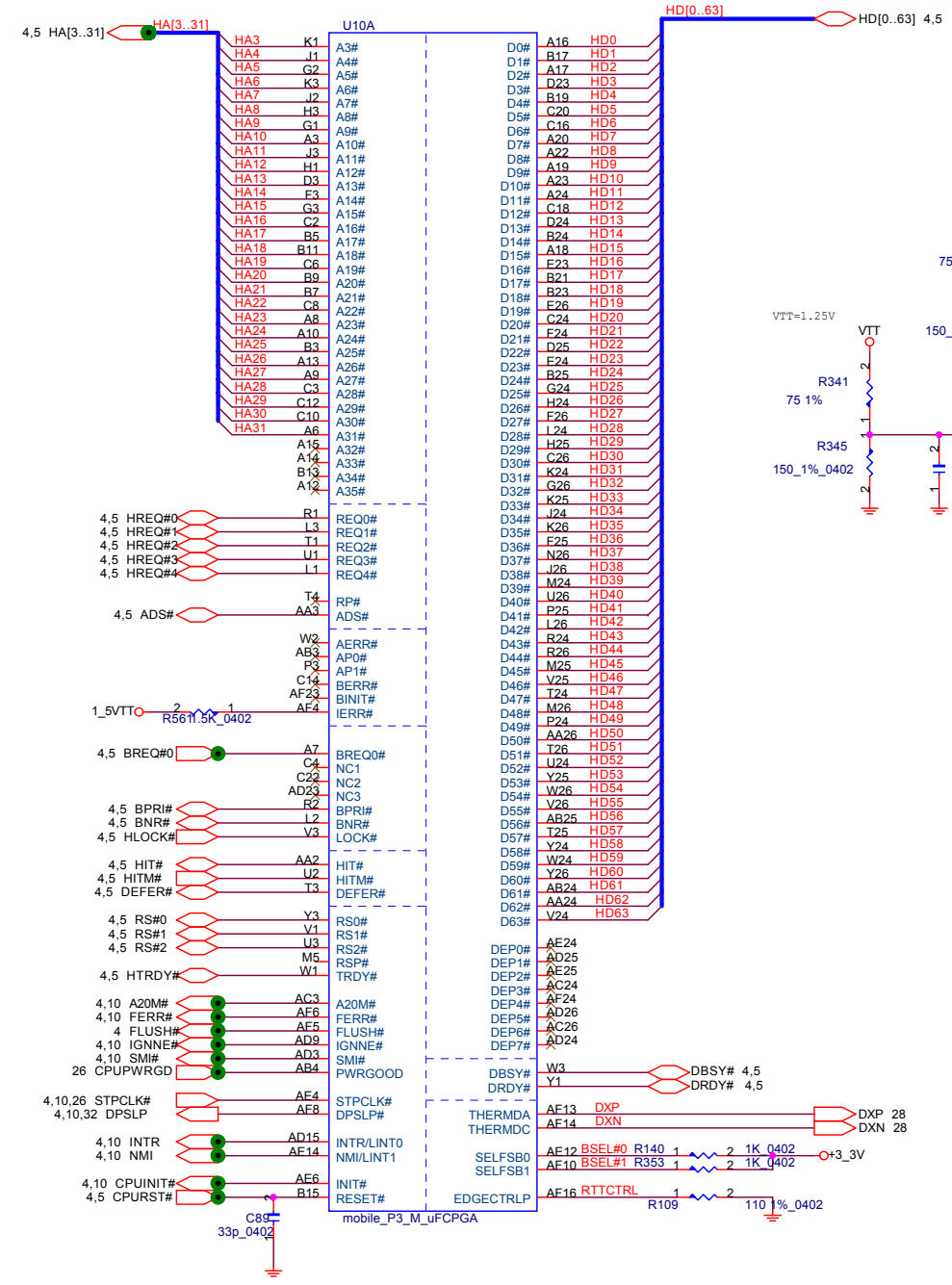

www.hocnghetructuyen.vn

FOXCONN TECHNOLOGY COPR.

Title: PROCESSOR

Document Number: TPC02-A-0.0

Date: Sunday, February 01, 2004

Sheet 3 of 33

Rev A

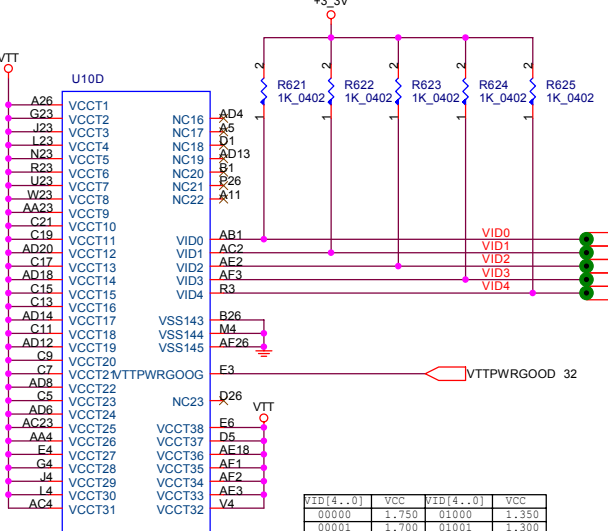
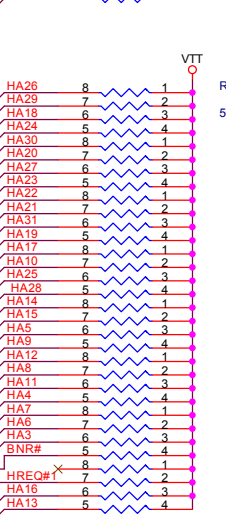
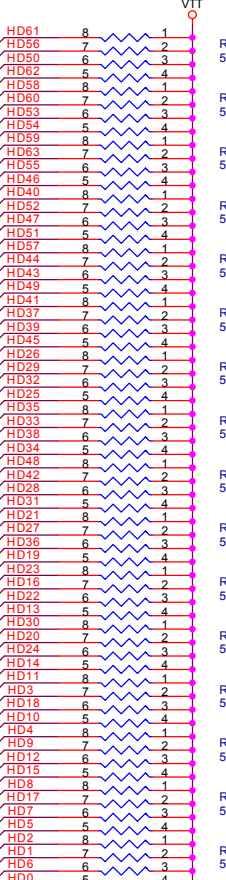
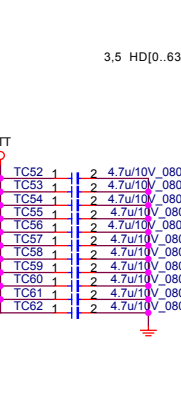
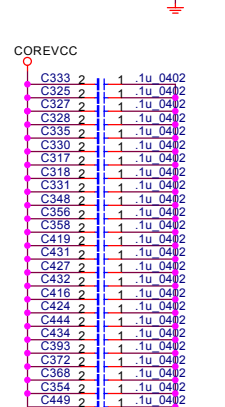
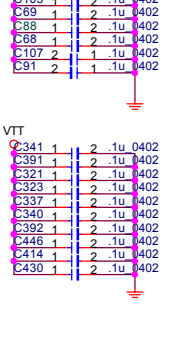
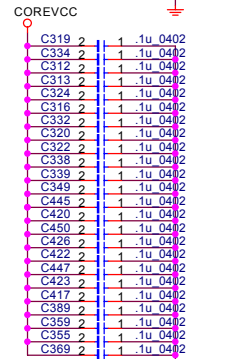
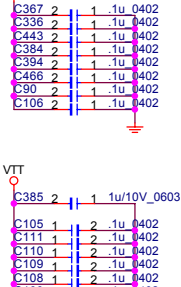
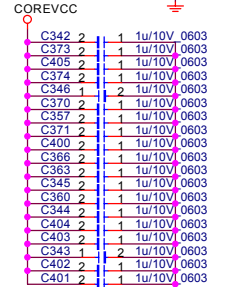
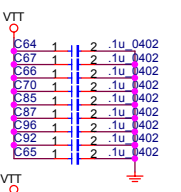
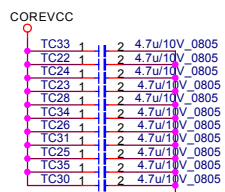

VID[4..0]	VCC	VID[4..0]	VCC
00000	1.750	01000	1.350
00001	1.700	01001	1.300
00010	1.650	01010	1.250
00011	1.600	01011	1.200
00100	1.550	01100	1.150
00101	1.500	01101	1.100
00110	1.450	01110	1.050
00111	1.400	01111	1.000

VID[4..0]	VCC	VID[4..0]	VCC
10000	0.975	01000	0.775
10001	0.950	01001	0.750
10010	0.925	01010	0.725
10011	0.900	01011	0.700
10100	0.875	01100	0.675
10101	0.850	01101	0.650
10110	0.825	01110	0.625
10111	0.800	01111	0.600

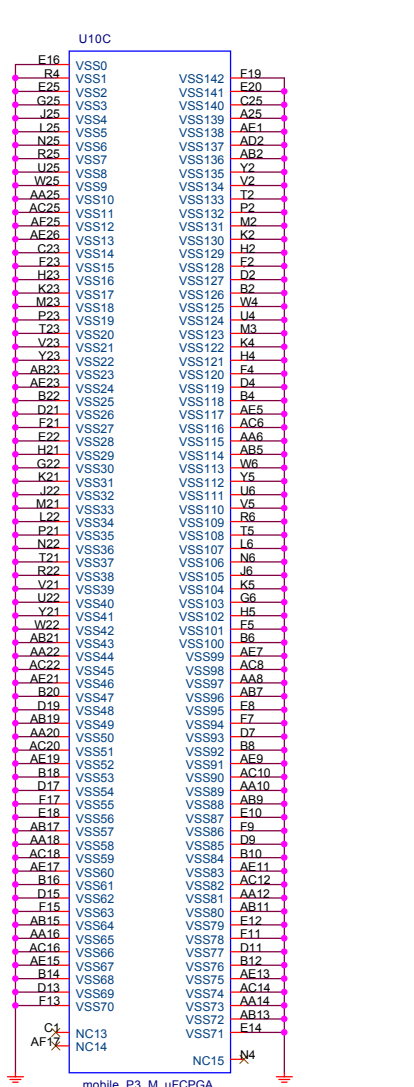
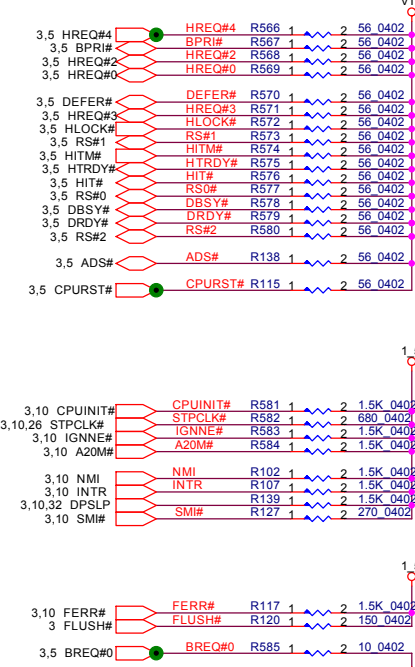

www.hocnghetructuyen.vn

FOXCONN TECHNOLOGY CORP.

Title: PROCESSOR

Document Number: TPC02-A-0.0

Date: Sunday, February 01, 2004 Sheet 4 of 33

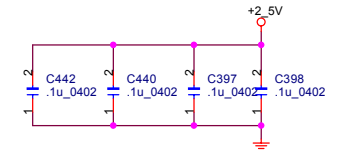
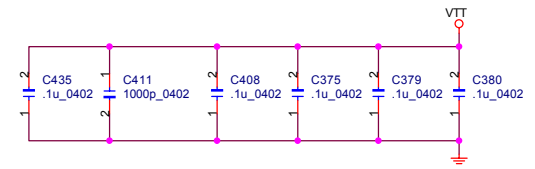
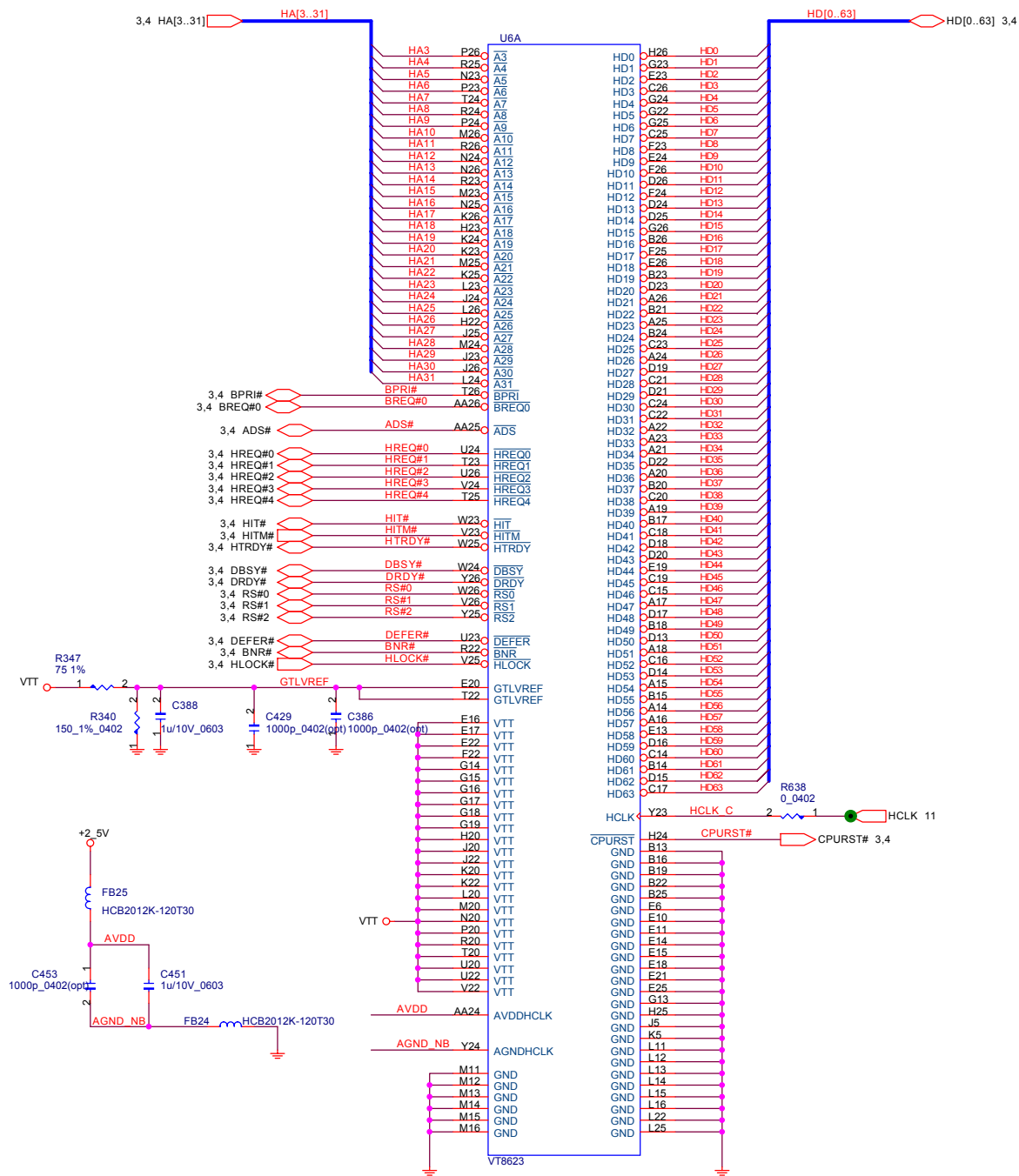

www.hocnghetructuyen.vn

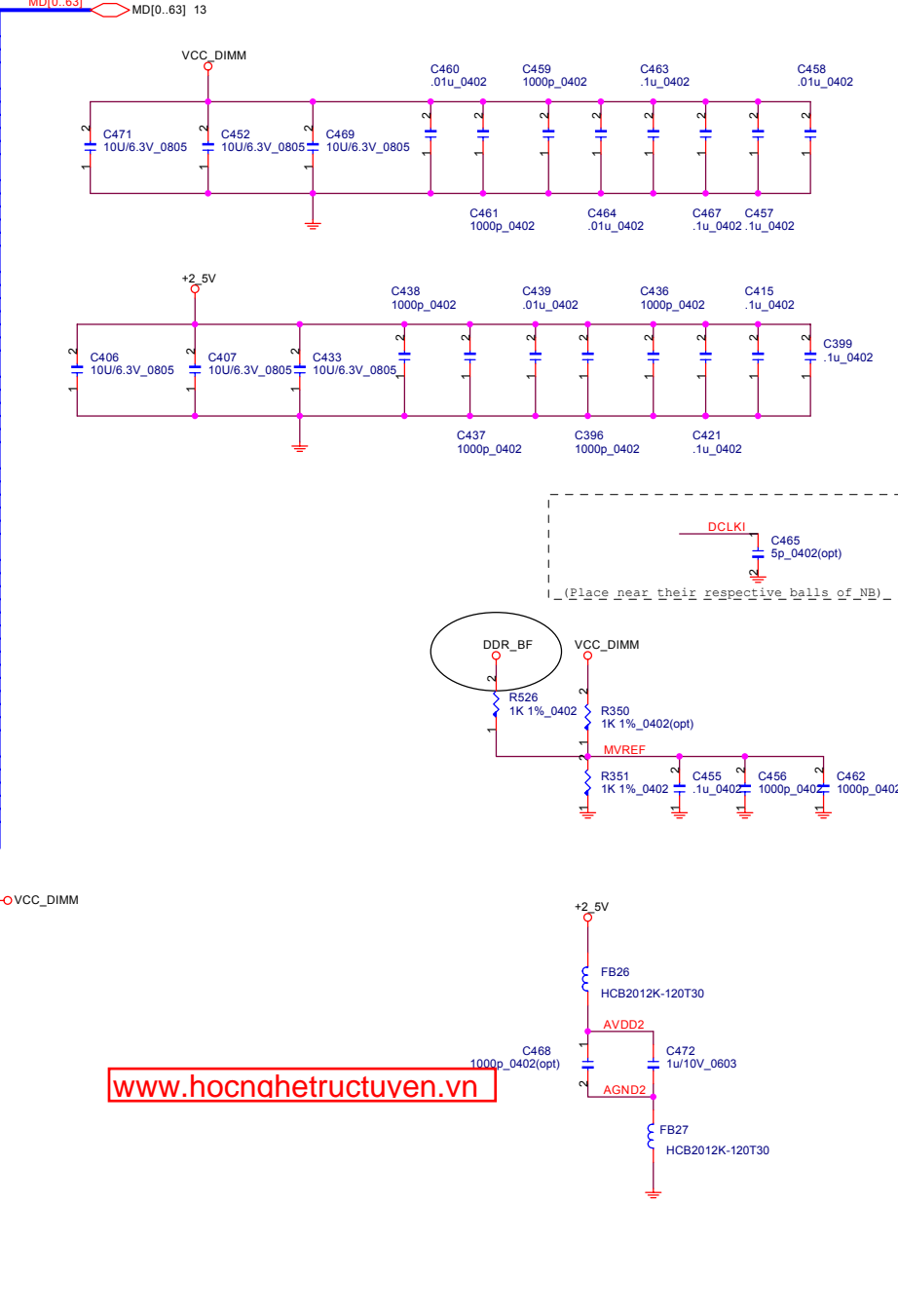
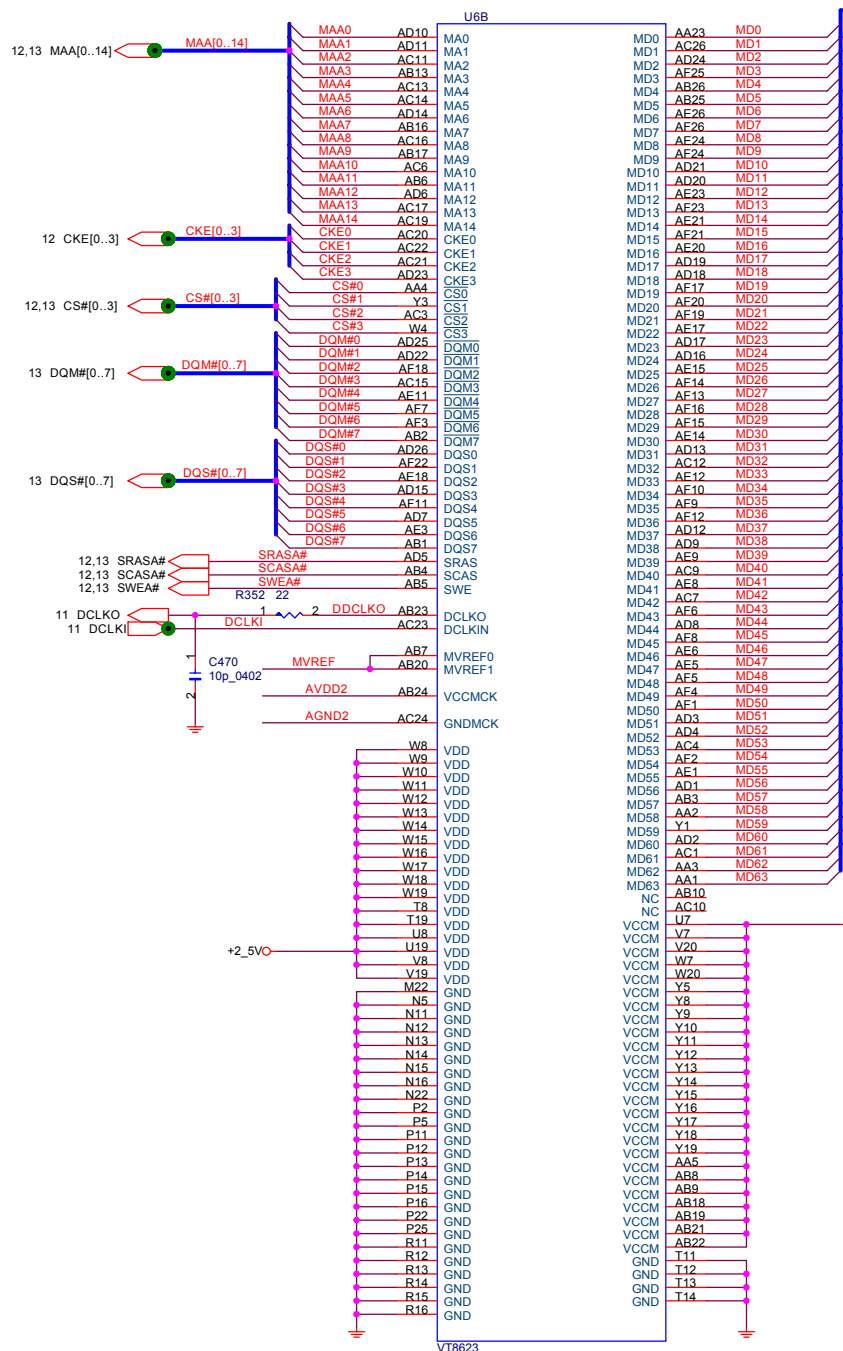

www.hocnhetructuven.vn

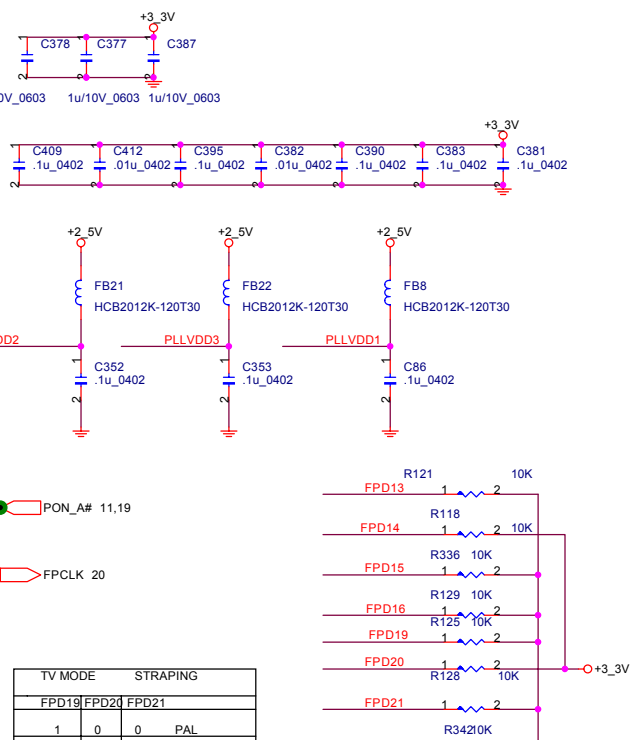
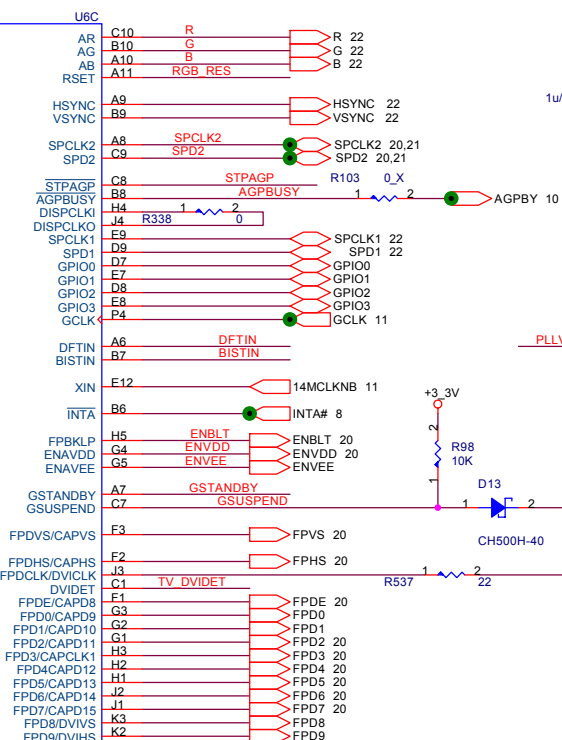
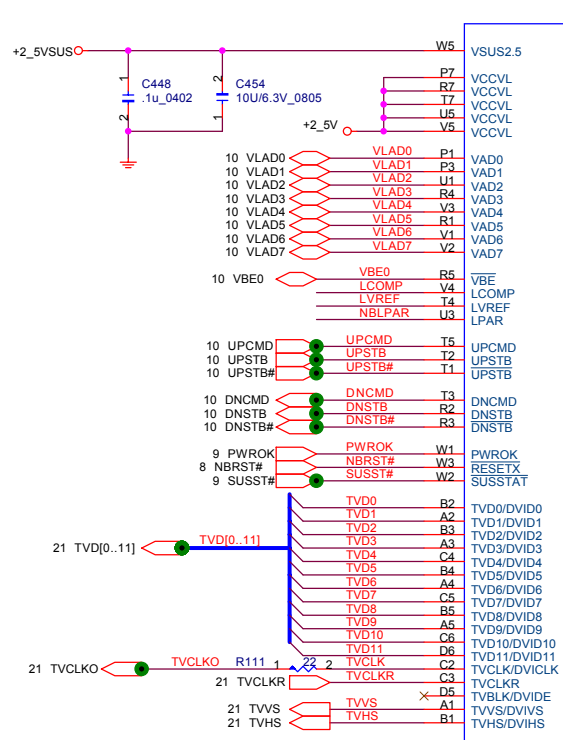

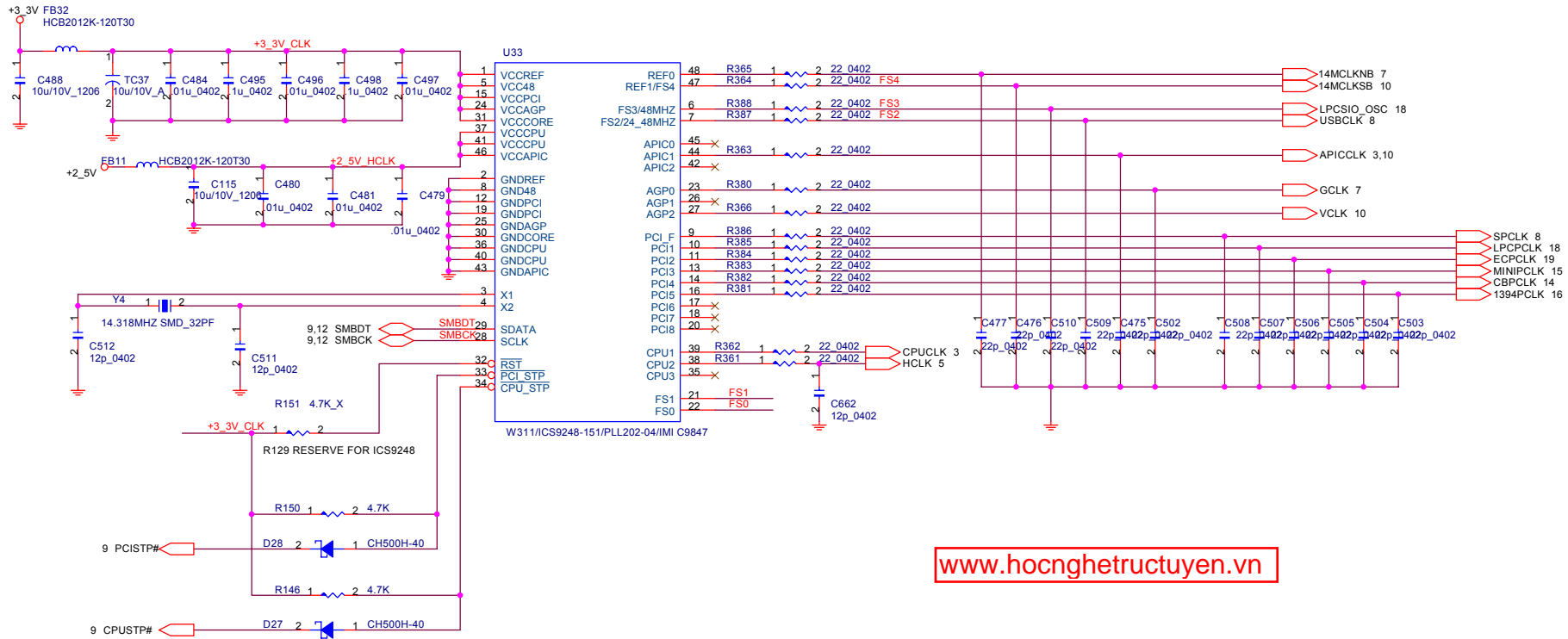

www.hocnghetructuyen.vn

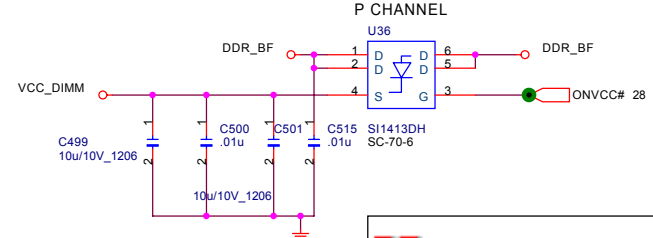
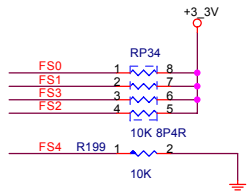
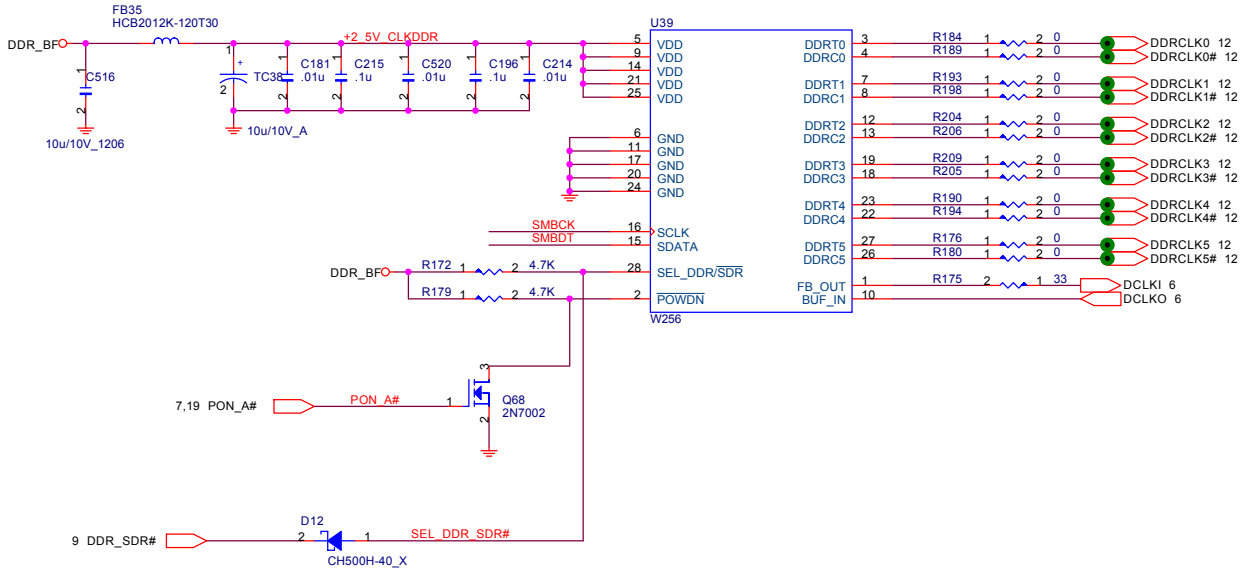

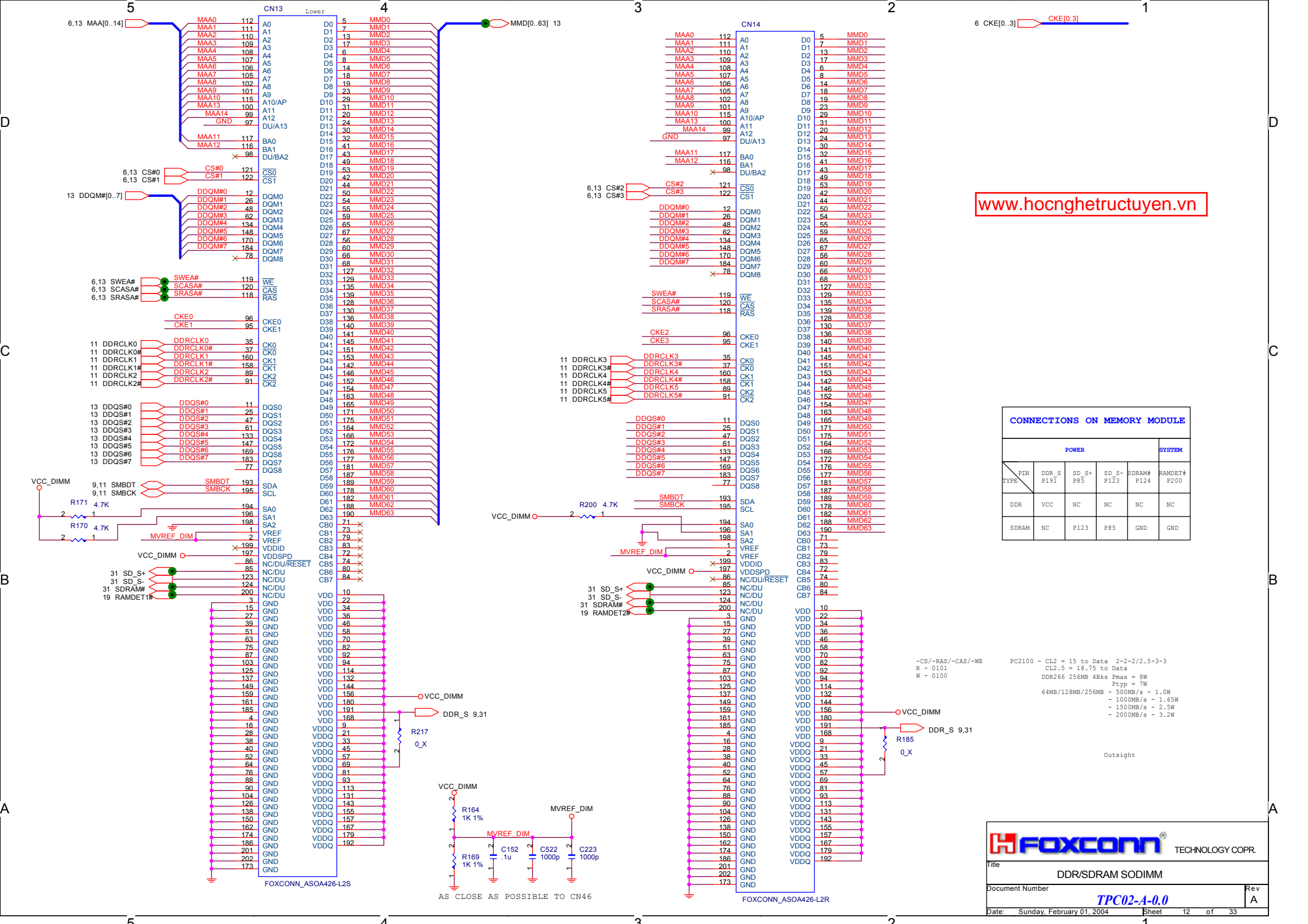

www.hocnghetructuyen.vn

CONNECTIONS ON MEMORY MODULE

		POWER				SYSTEM
PIN	TYPE	DDR_S P192	SD_S+ P85	SD_S- P123	SDRAM# P124	RAMDET# P200
DDR	VCC	VCC	NC	NC	NC	NC
SDRAM	NC	NC	P123	P85	GND	GND

PC2100 - CL2 = 15 to Data 2-2-2/2.5-3-3
 CL2.5 = 18.75 to Data
 DDR266 256MB 4Bks Pmax = 8W
 Ptyp = 7W
 64MB/128MB/256MB - 500MB/s - 1.0W
 - 1000MB/s - 1.65W
 - 1500MB/s - 2.5W
 - 2000MB/s - 3.2W

FOXCONN TECHNOLOGY COPR.

title
 DDR/SDRAM SODIMM
 Document Number
TPC02-A-0.0
 Date: Sunday, February 01, 2004

Rev
 A

Sheet 12 of 33

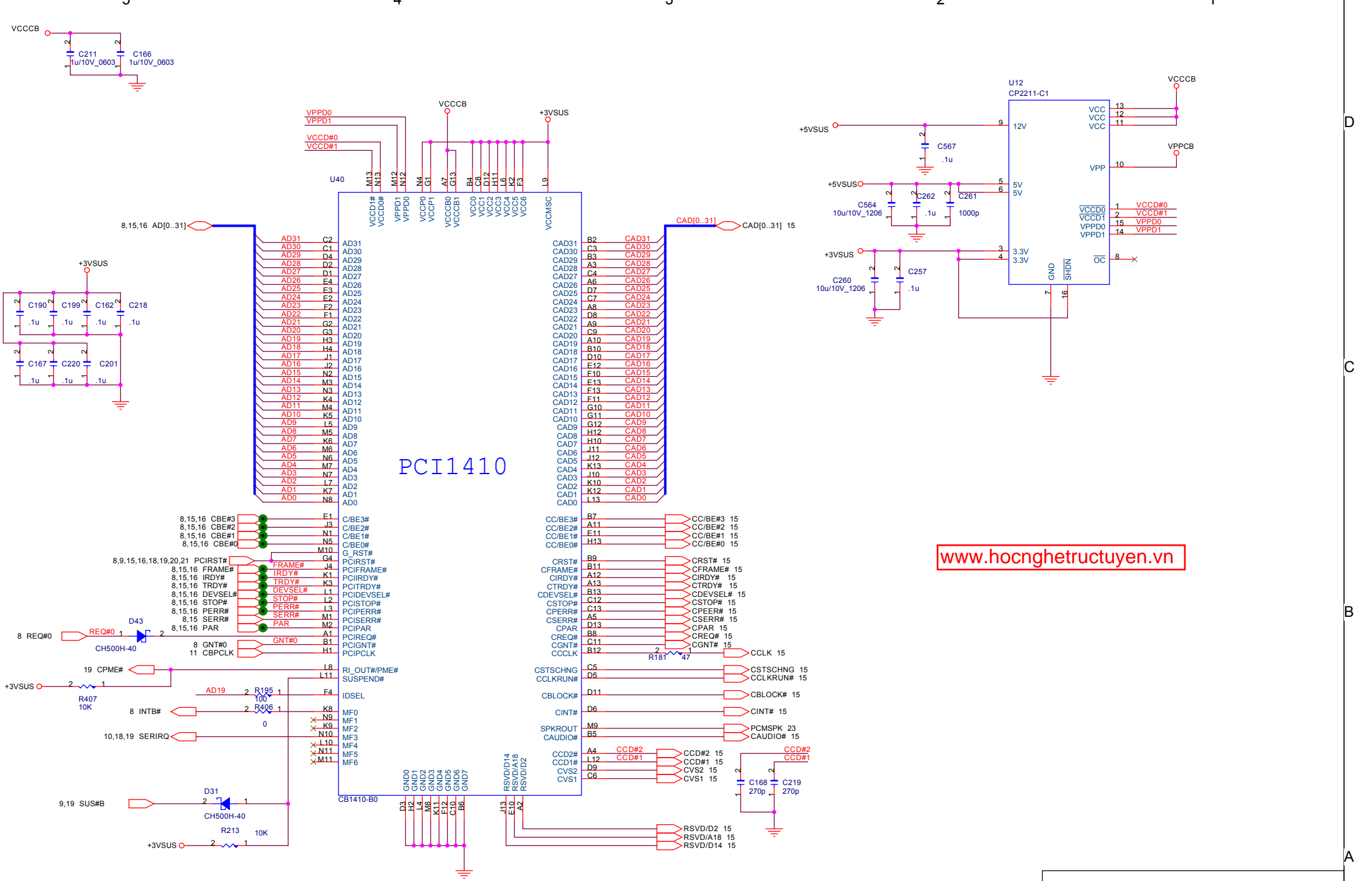

PCI1410

www.hocnghetructuyen.vn

FOXCONN TECHNOLOGY CORP.	
Title CARD BUS EN1410	
Document Number	Rev A
TPC02-A-0.0	
Date: Sunday, February 01, 2004	Sheet 14 of 33

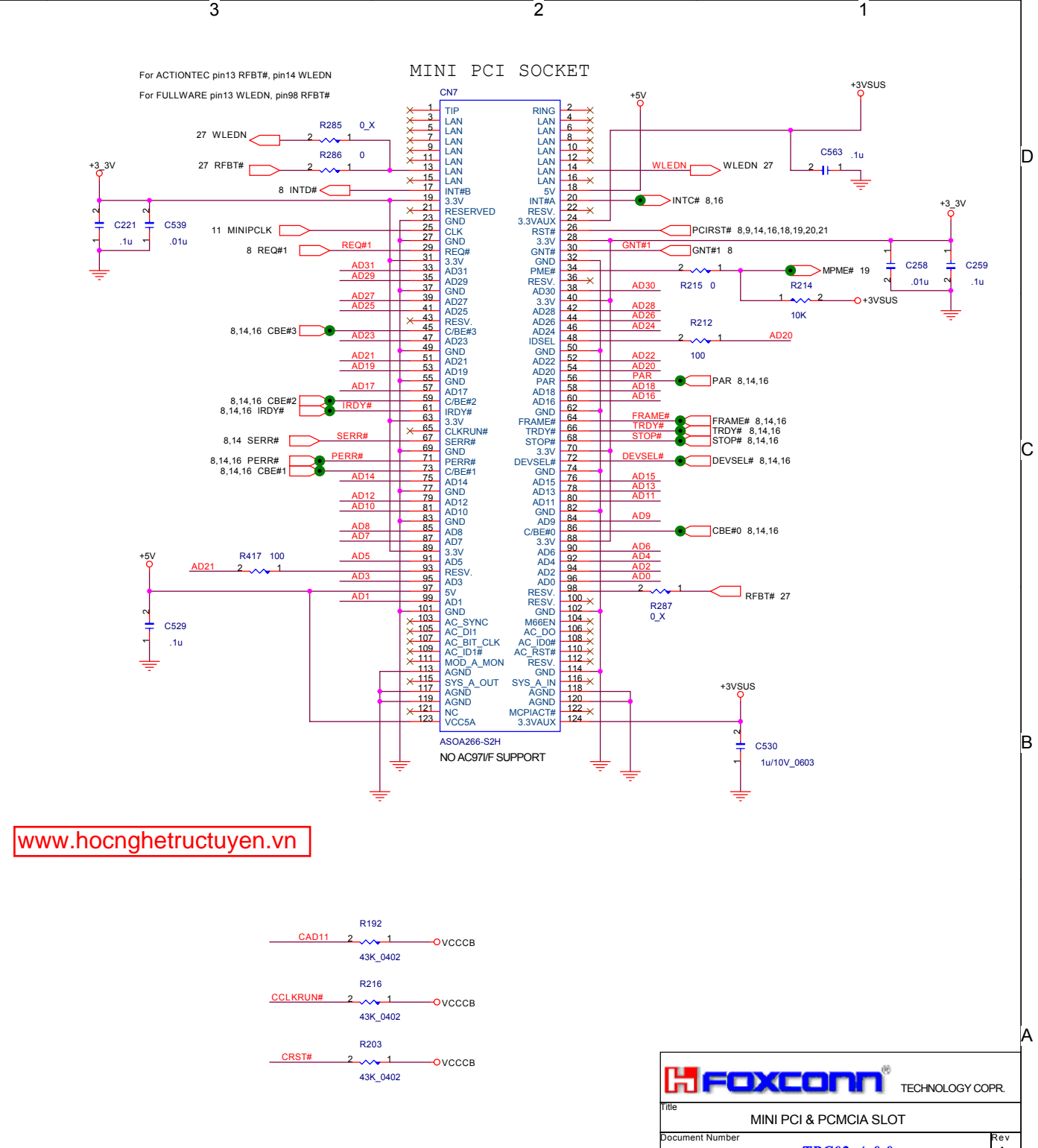
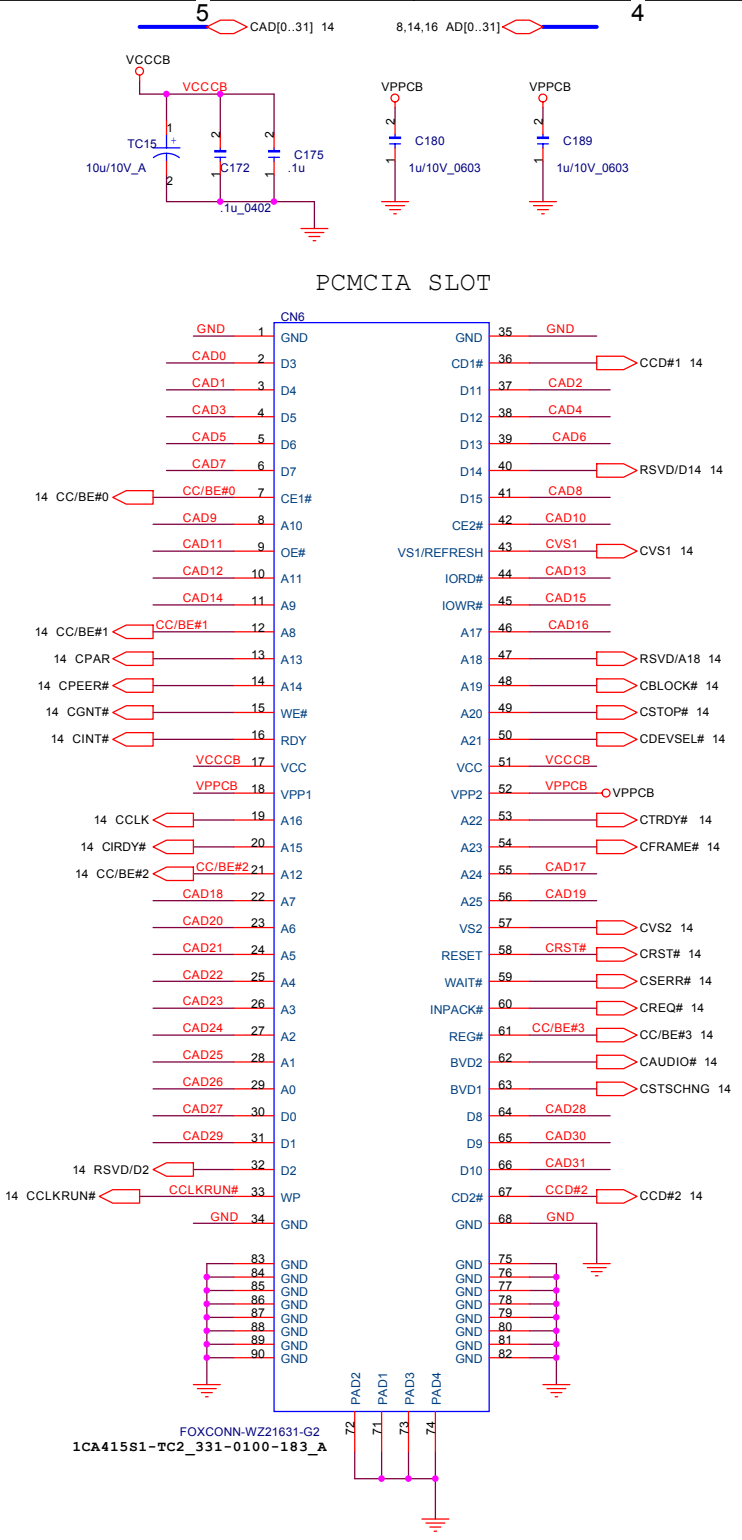

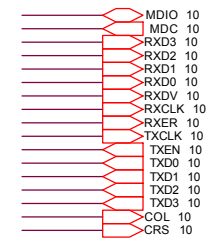
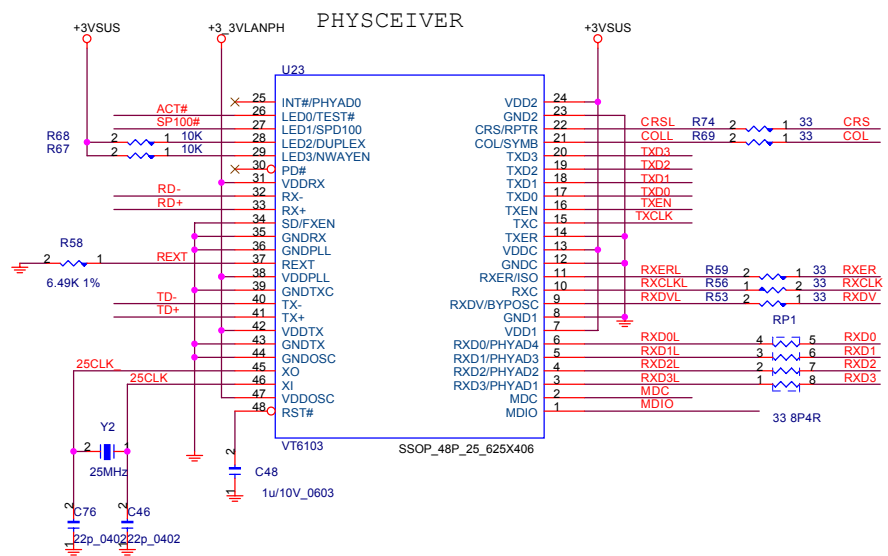
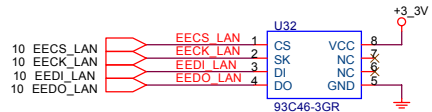
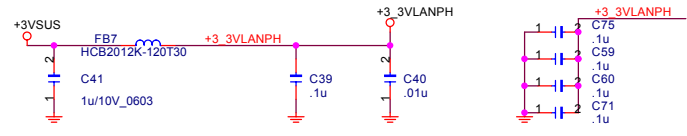

www.hocnghetructuyen.vn

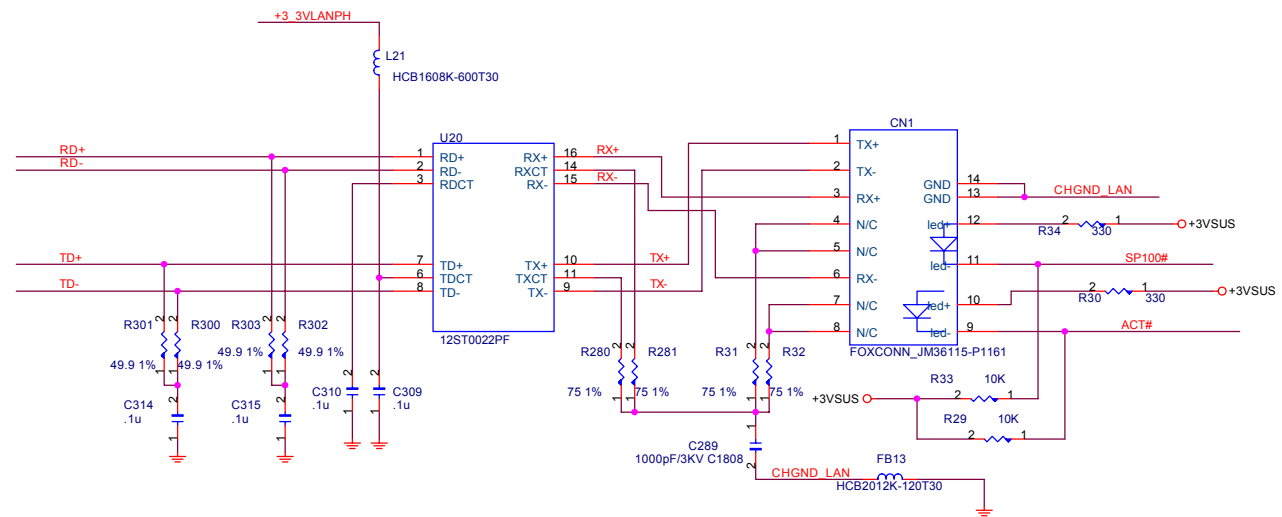

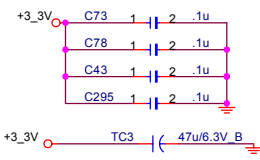
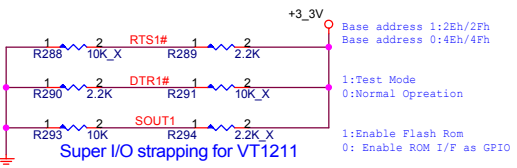
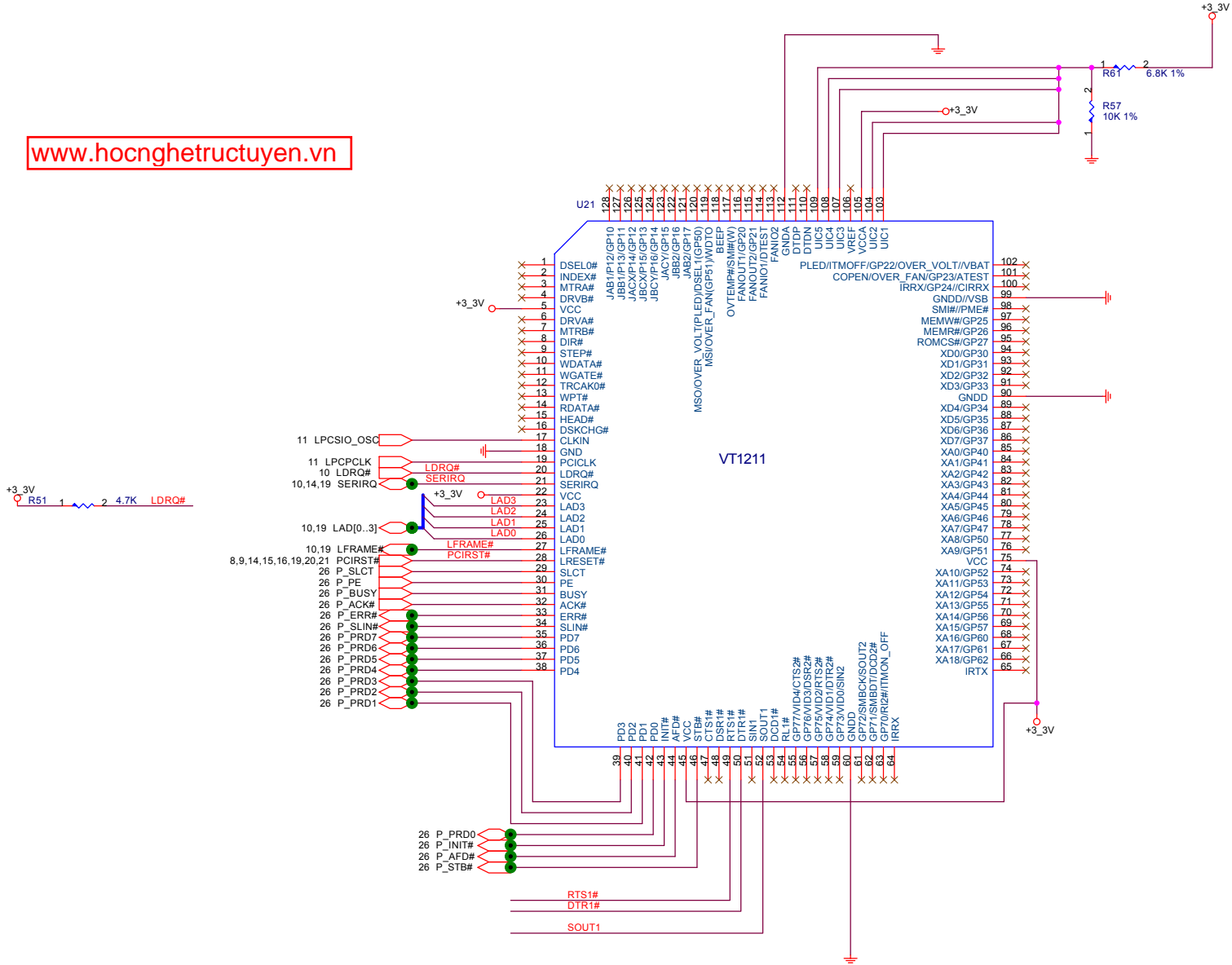

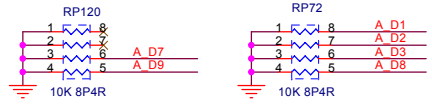

NEED PULL DOWN
AS A/D & D/A UNUSED

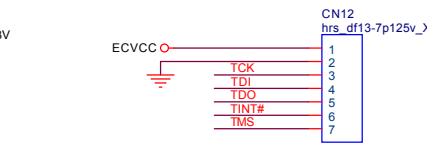
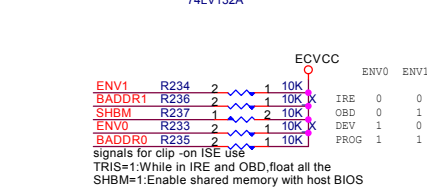
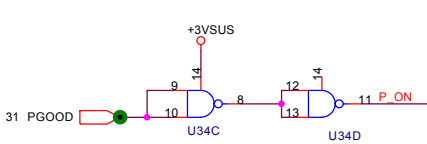
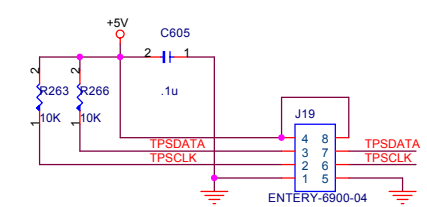
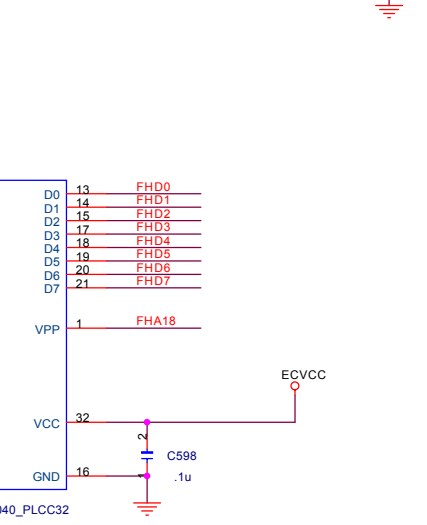
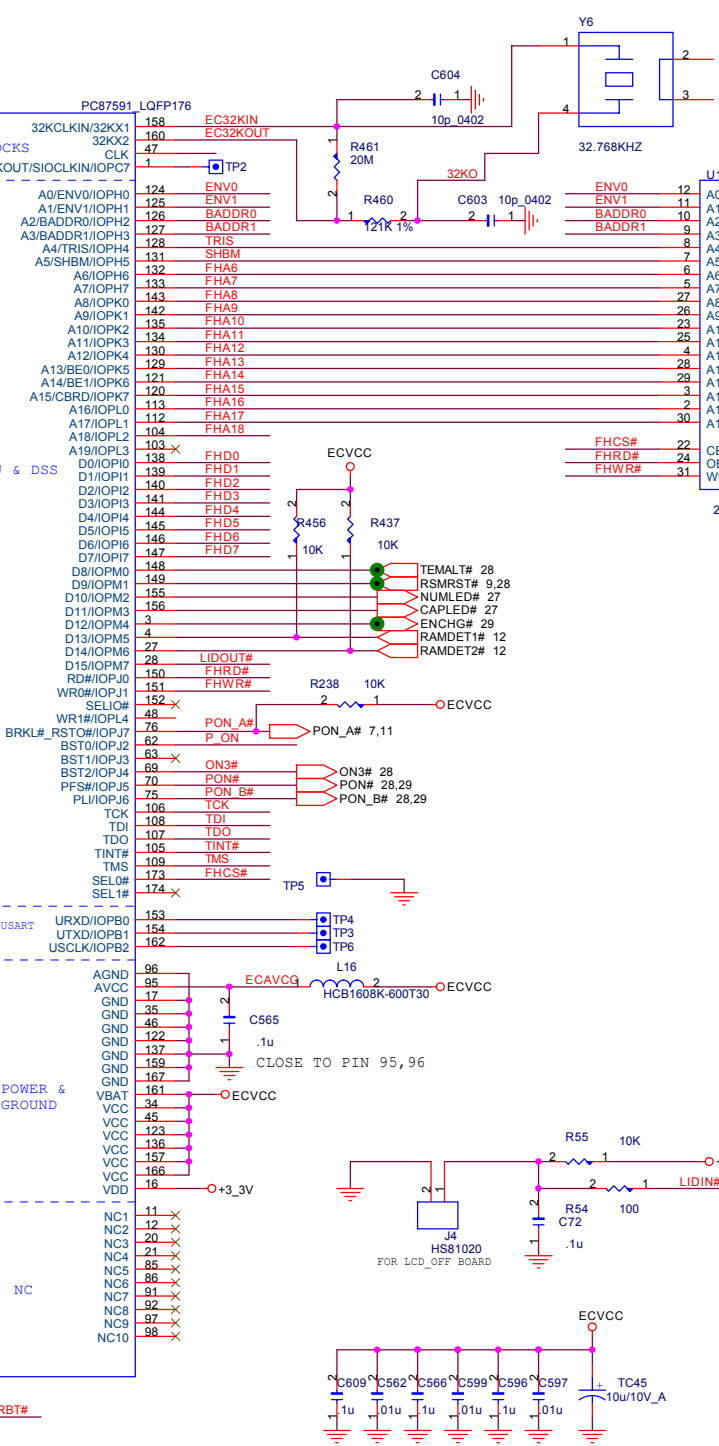
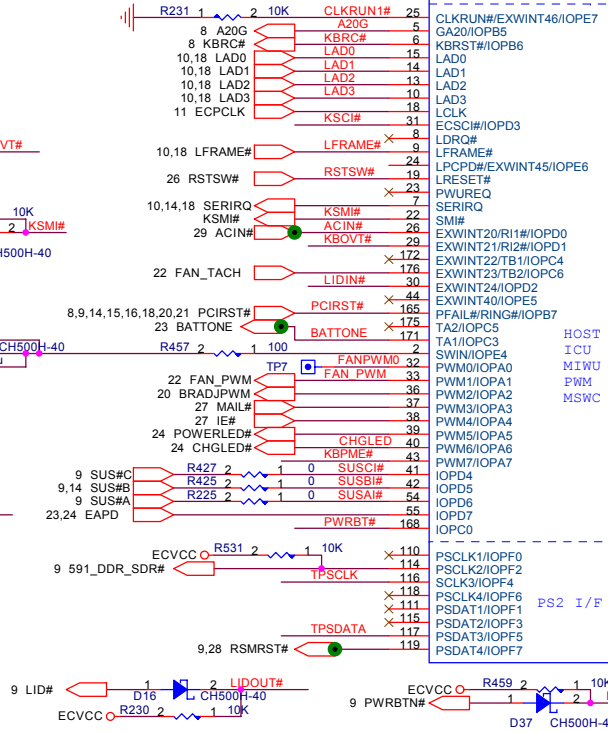
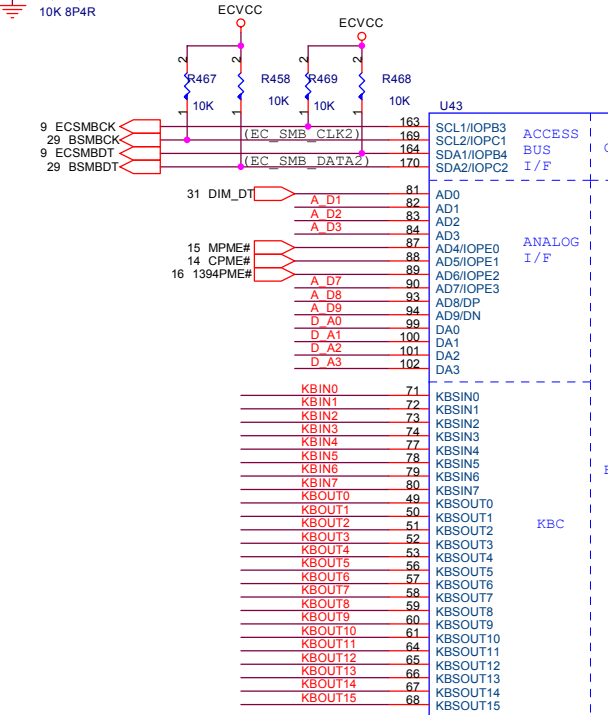
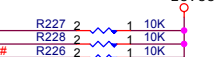
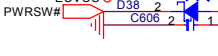
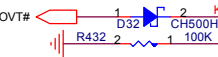
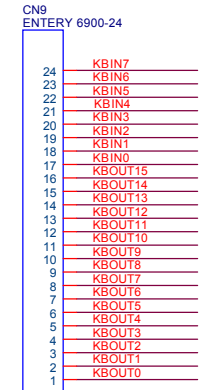
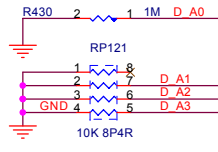

FOXCONN TECHNOLOGY COPR.
Title: KBC/EC PC87591
Document Number: TPC02-A-0.0
Date: Sunday, February 01, 2004
Sheet 19 of 33

LVDS TRANSMITTER

U7

FFPD18	44	TA0	VCC	2
FFPD19	45	TA1	VCC	8
FFPD20	47	TA2	VCC	21
FFPD21	48	TA3	R/F(NC)	14
FFPD22	1	TA4		
FFPD23	3	TA5		
FFPD10	4	TA6		
FFPD11	6	TB0	TA+	40
FFPD12	7	TB1	TA-	41
FFPD13	9	TB2	TC+	38
FFPD14	10	TB3	TC-	39
FFPD15	12	TB4	TCLK+	34
FFPD2	13	TB5	TCLK-	35
FFPD3	15	TB6	LL1C+	32
			LL1C-	33
FFPD4	16	TC0	PLLVC	29
FFPD5	18	TC1	PLLGN	28
FFPD6	19	TC2	PLLGN	30
FFPD7	20	TC3	LVDS VCC	37
FFPD8	21	TC4	LVDS GND	31
FFPD9	22	TC5	LVDS GND	36
FFPD1	23	TC6	LVDS GND	42
FFPD2	24	TC6	NC	43
FFPD3	25	TC6	GND	5
			GND	11
			GND	17
			GND	24
			GND	46

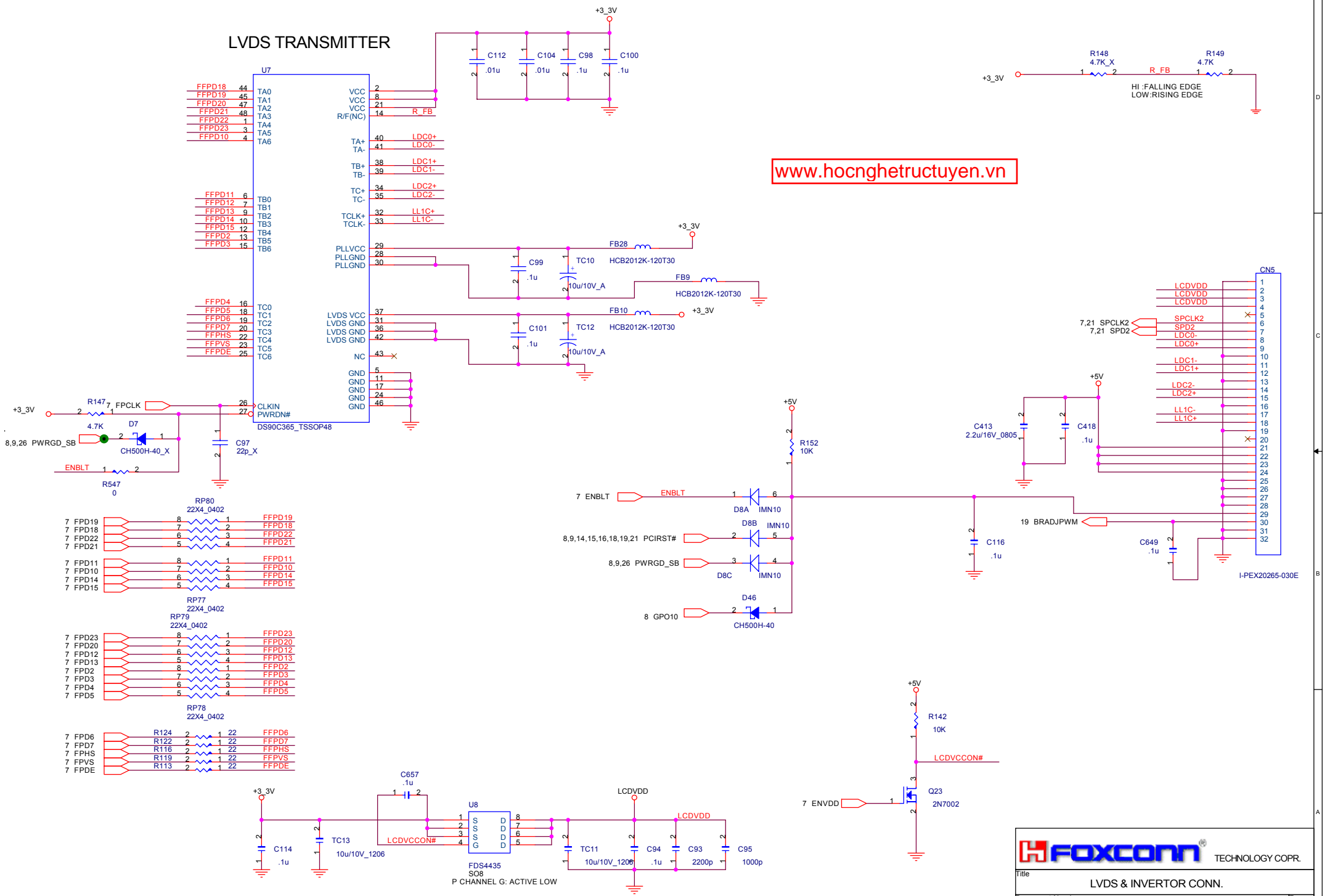

www.hocnghetructuyen.vn

FOXCONN TECHNOLOGY CORP.

Title: LVDS & INVERTOR CONN.

Document Number: TPC02-A-0.0

Date: Sunday, February 01, 2004

Sheet 20 of 33

Rev A

7 TVD[0..11] TVD[0..11]

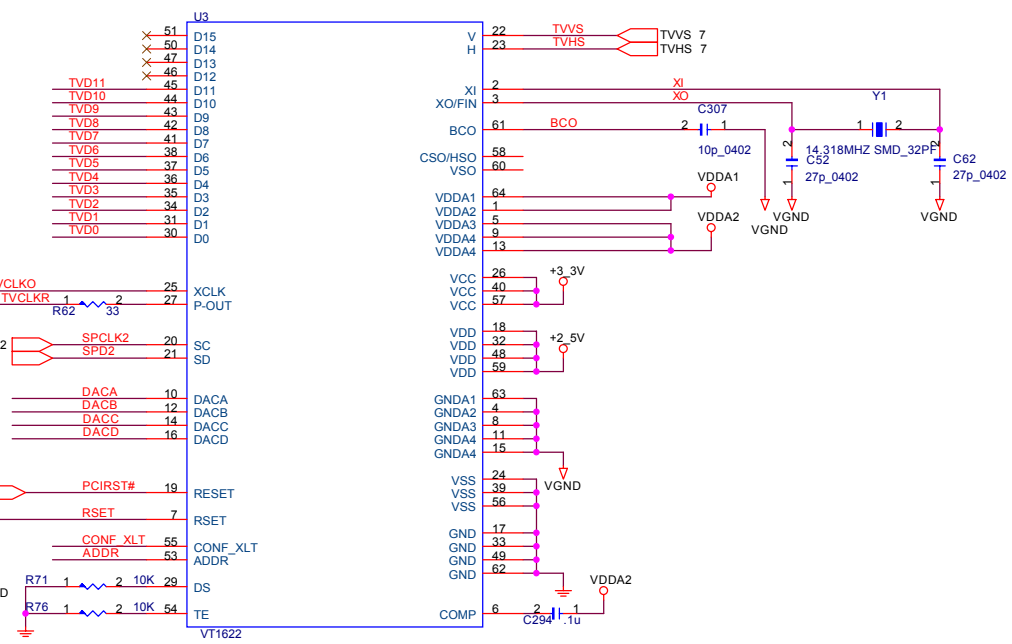
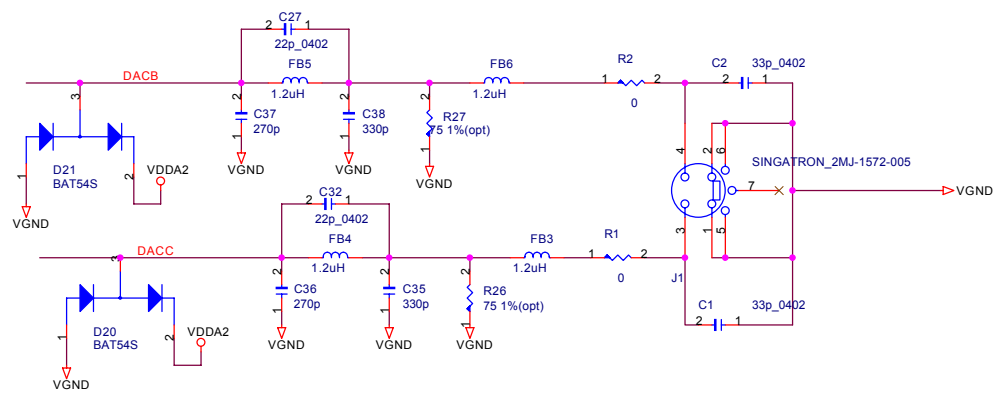

www.hocnghetructuyen.vn

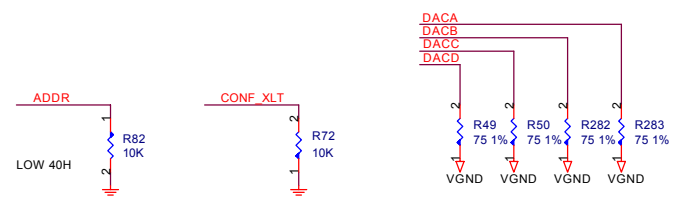
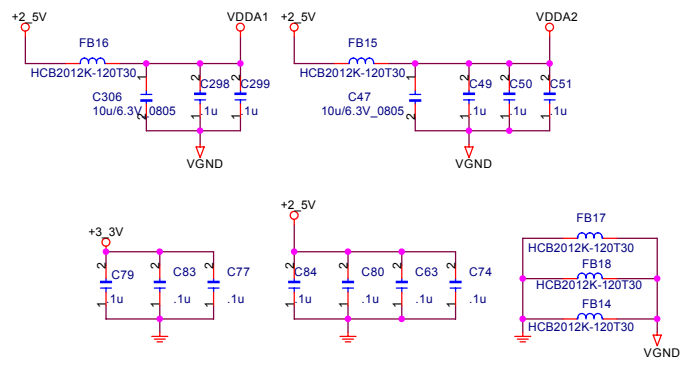

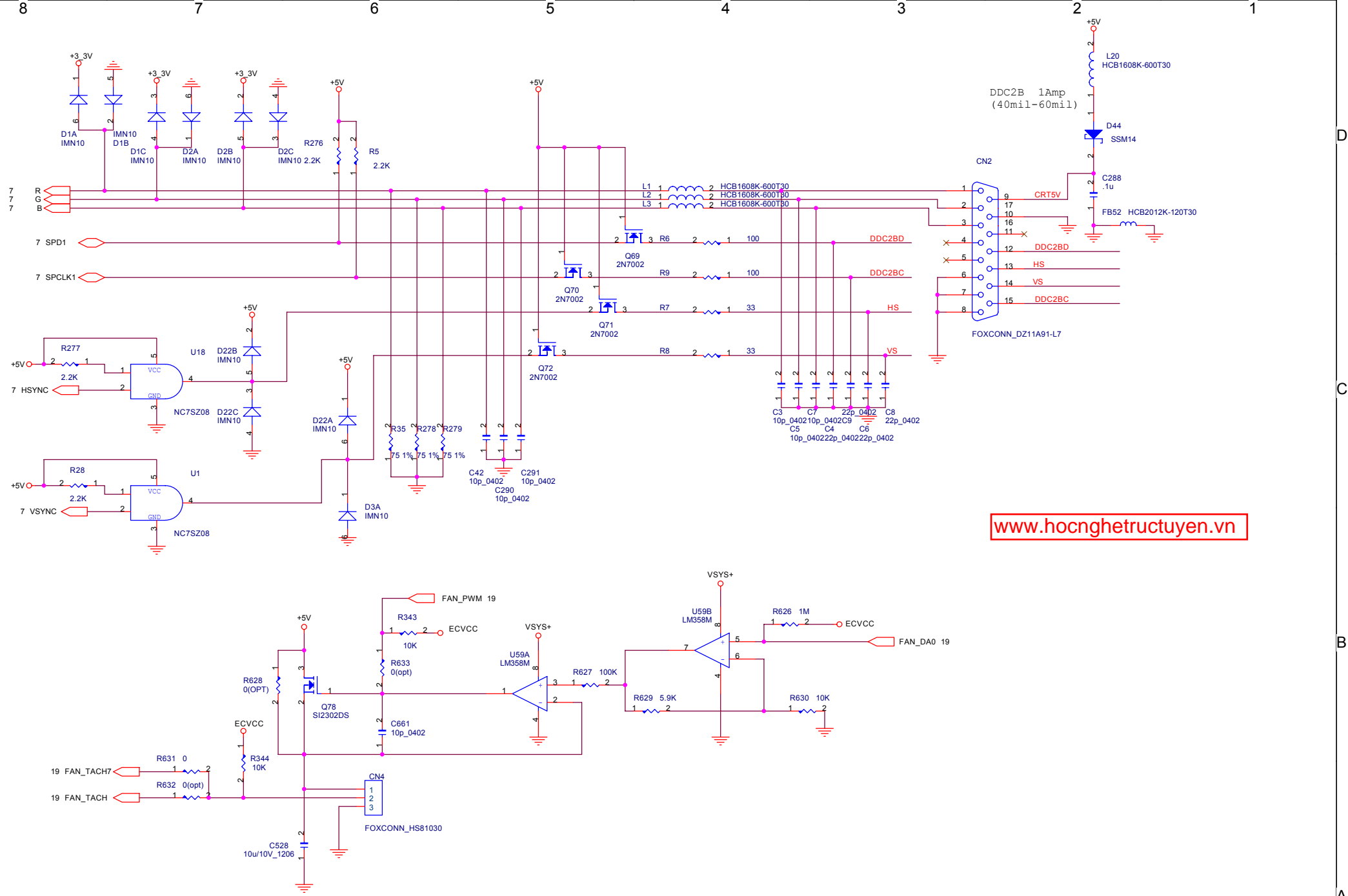

www.hocnghetructuyen.vn

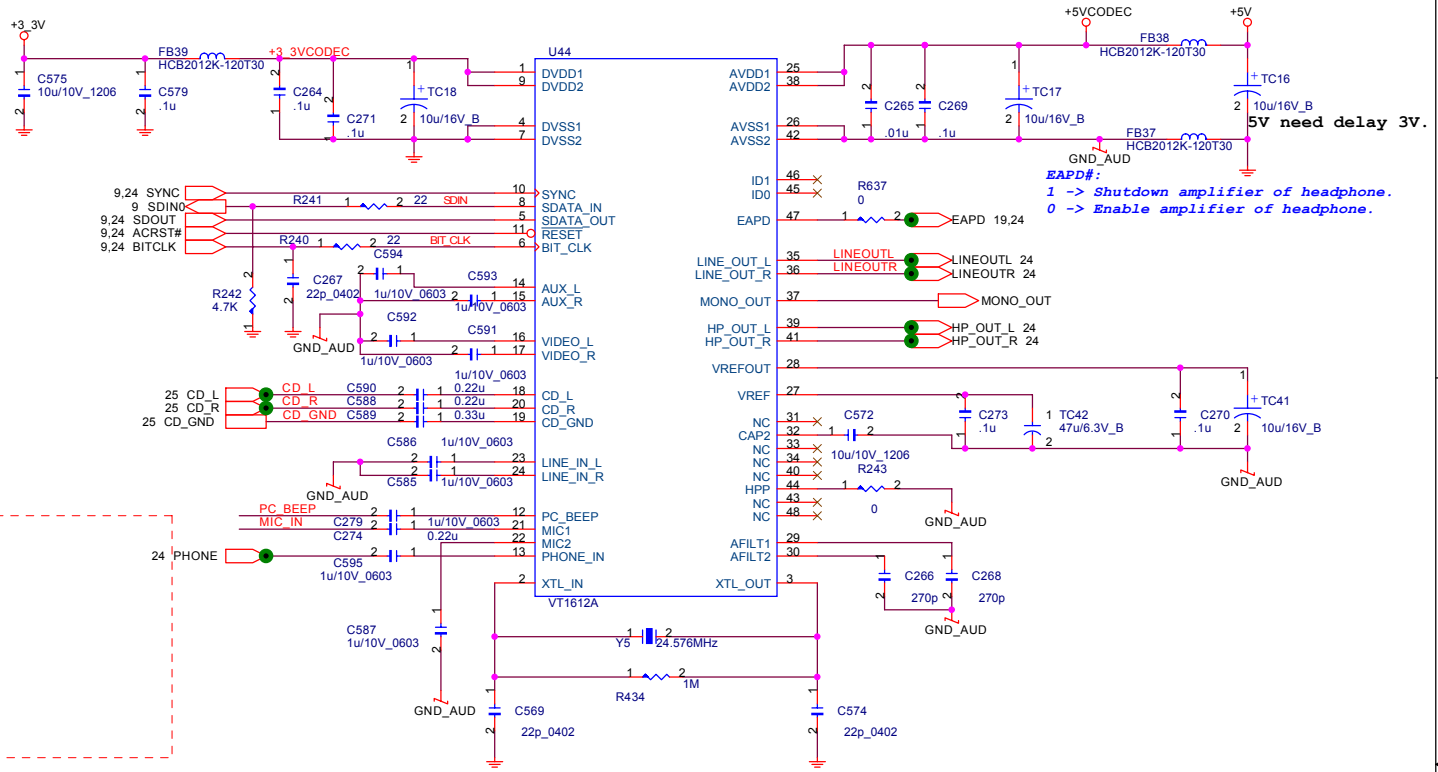
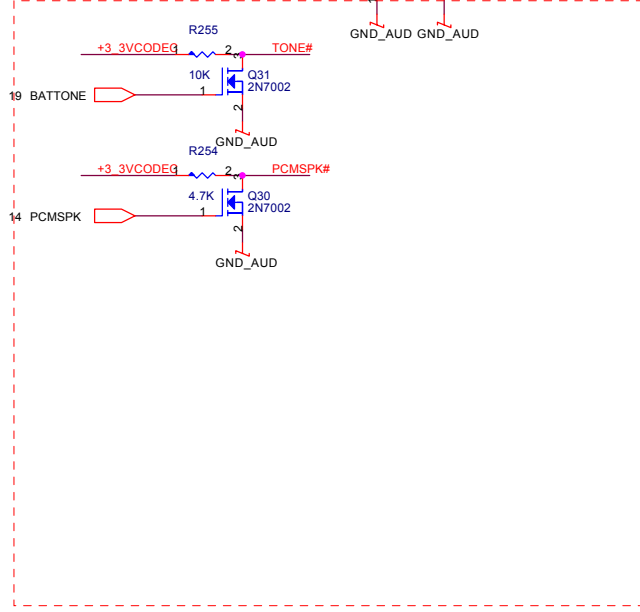
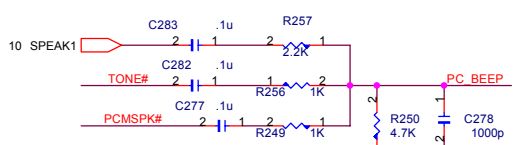

EAPD#:
 1 -> Shutdown amplifier of headphone.
 0 -> Enable amplifier of headphone.

Must be to close to internal MIC

Must be to close to AC97 Codec

www.hocnghetructuyen.vn

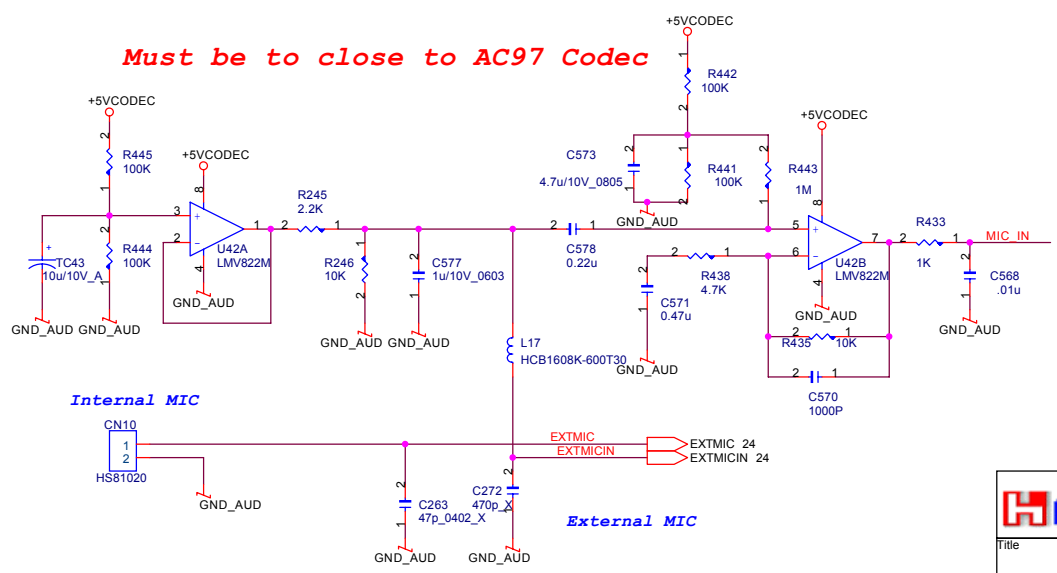

FOXCONN TECHNOLOGY CORP.

Title: AC97 CODEC & AUDIO MIC

Document Number: TPC02-A-0.0

Date: Sunday, February 01, 2004

Sheet 23 of 33

Rev A

Gain0, Gain1:
 00: 6dB (Av=2) <= Default
 01: 10dB
 10: 15.6dB
 11: 21.6dB

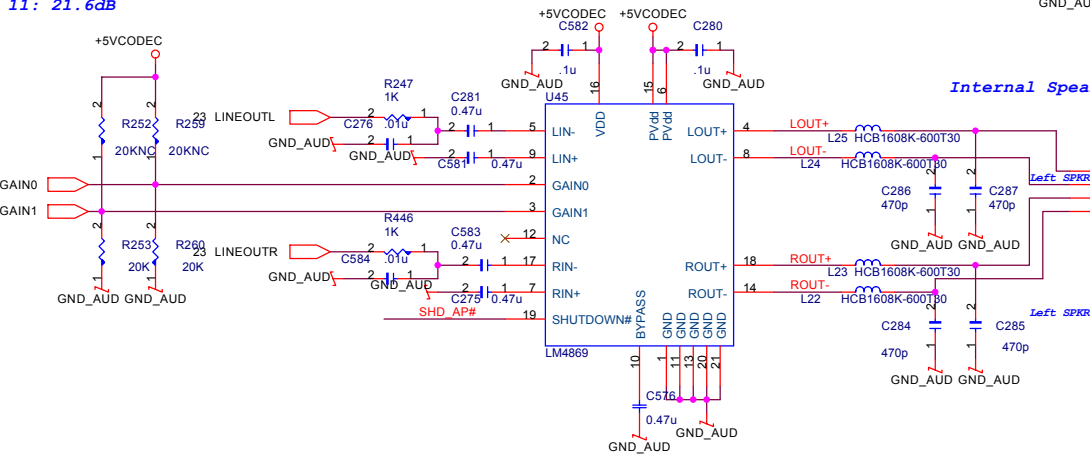

Internal Speaker

www.hocnghetructuyen.vn

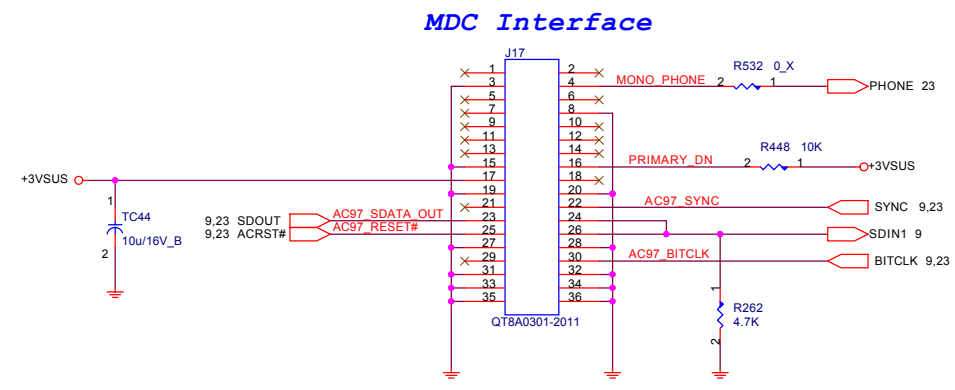

MDC Interface

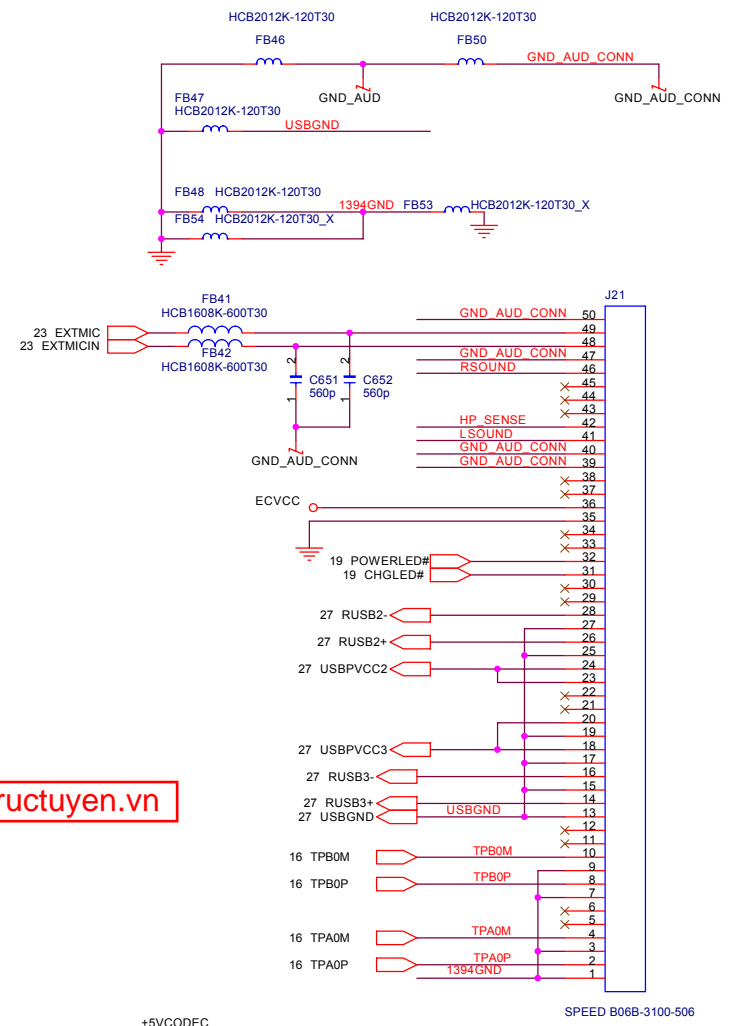
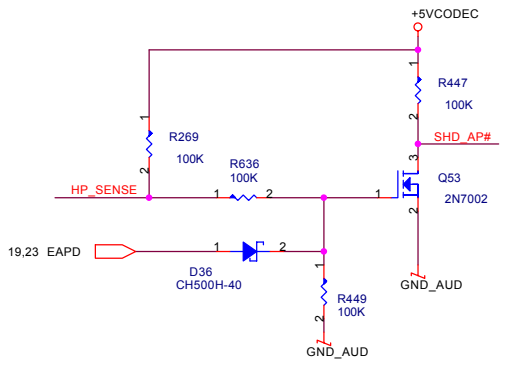

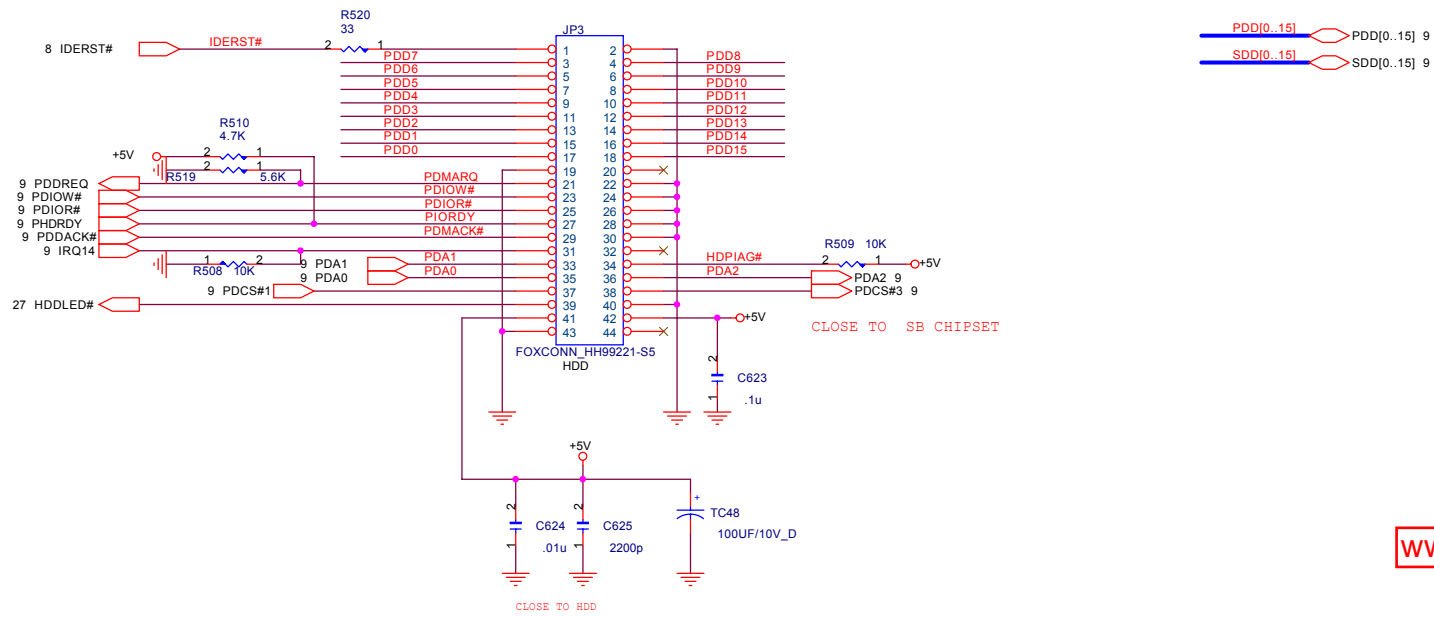

www.hocnghetructuyen.vn

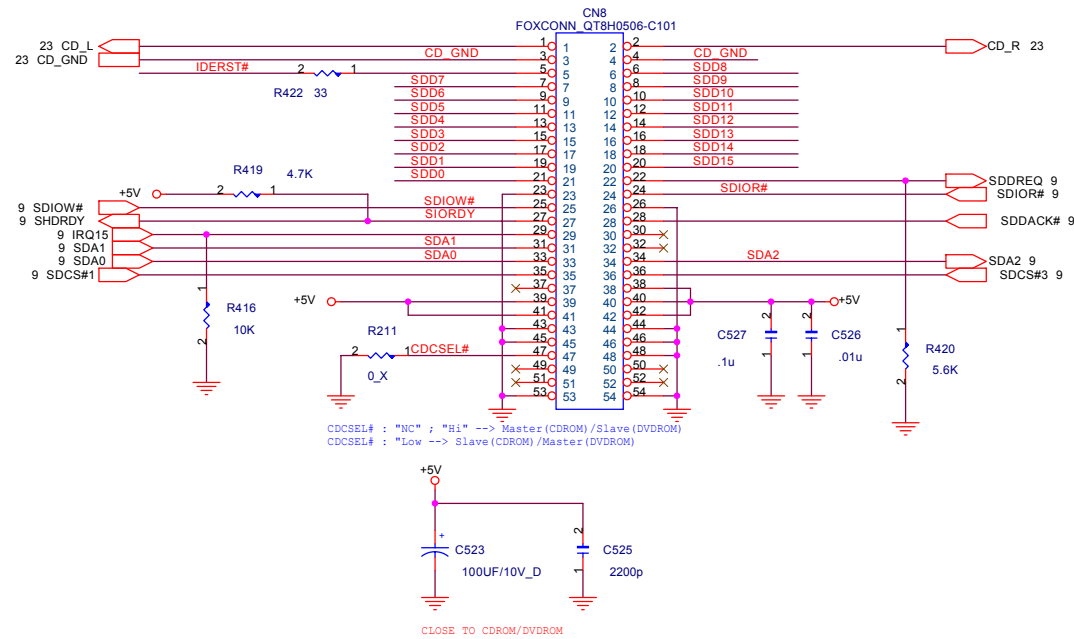

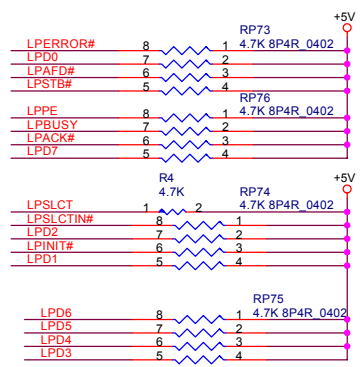
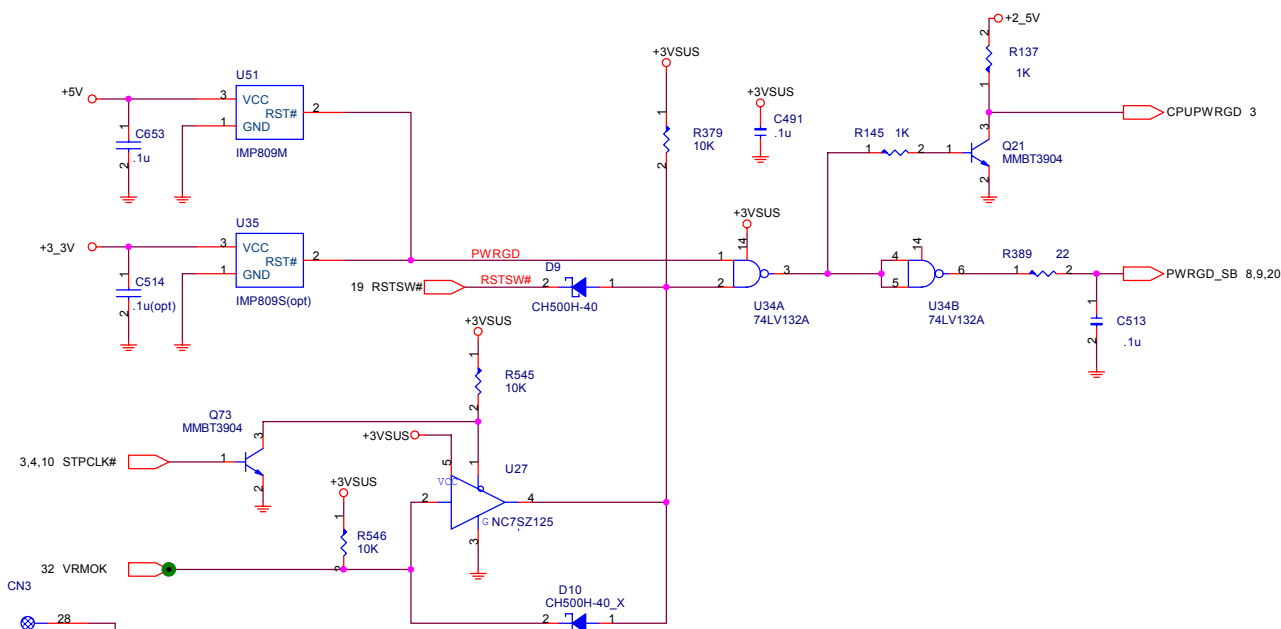

www.hocnghetructuyen.vn

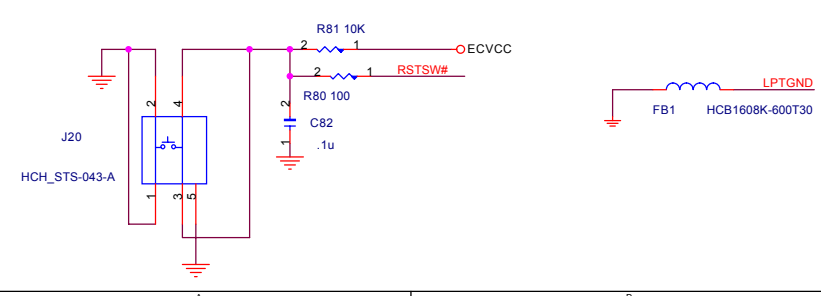
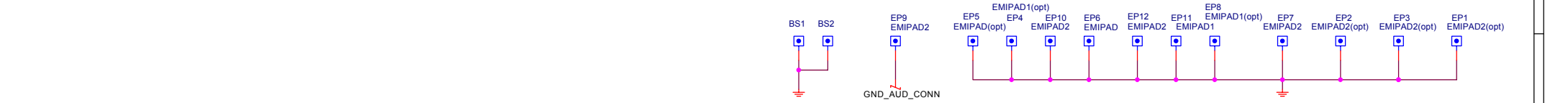
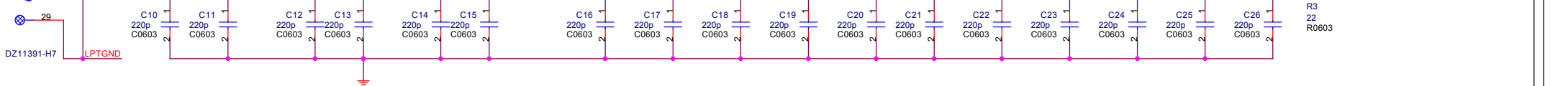
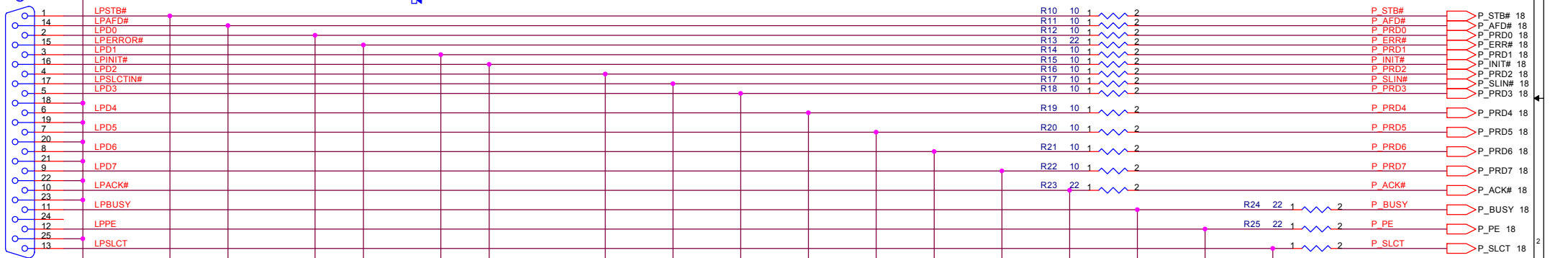

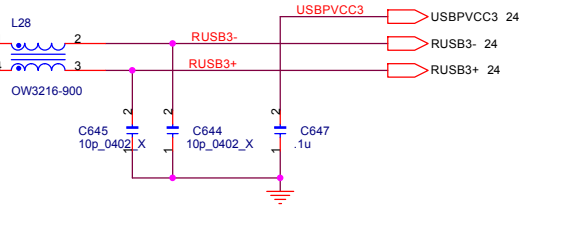
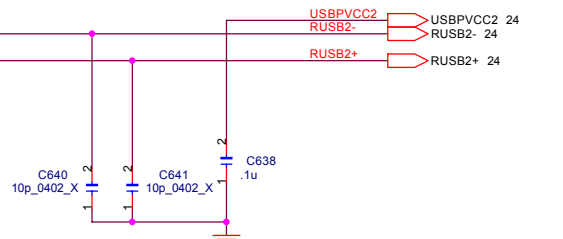
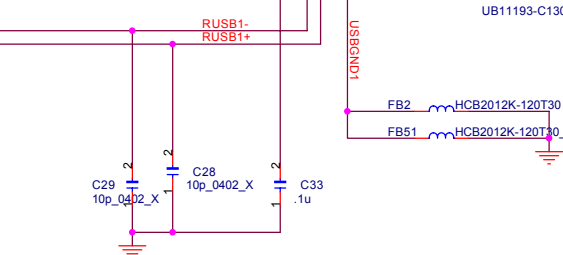
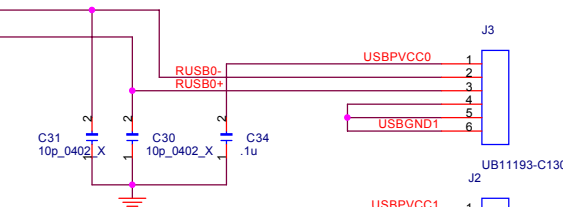
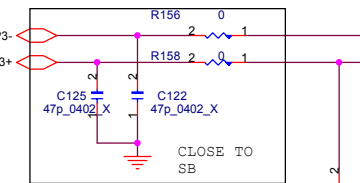
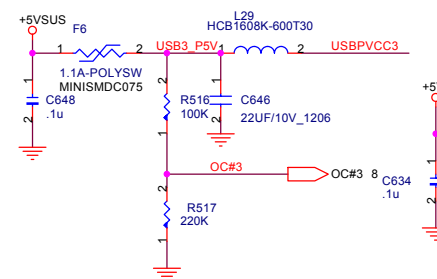
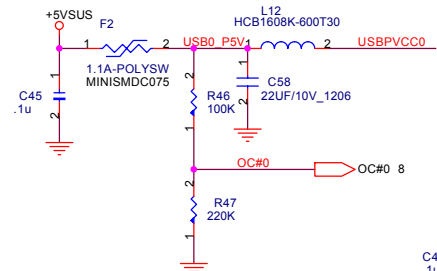
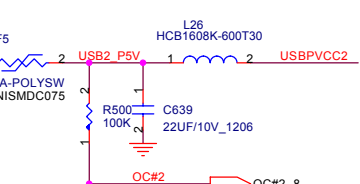
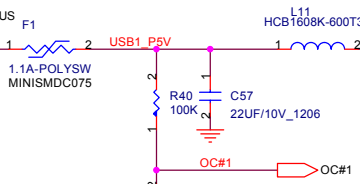
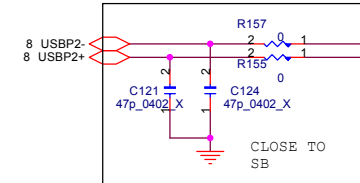
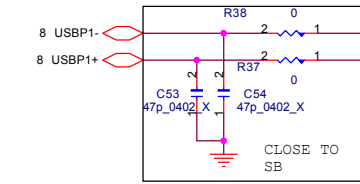
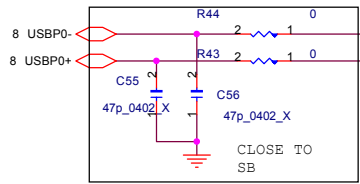
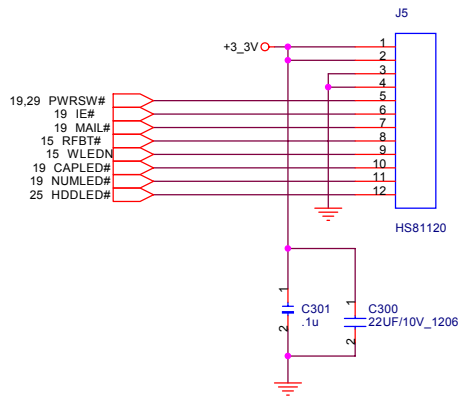

www.hocnghetructuyen.vn

FOXCONN TECHNOLOGY COPR.	
Title USB, LED BUTTON	
Document Number	Rev A
Date: Sunday, February 01, 2004 Sheet 27 of 33 TPC02-A-0.0	

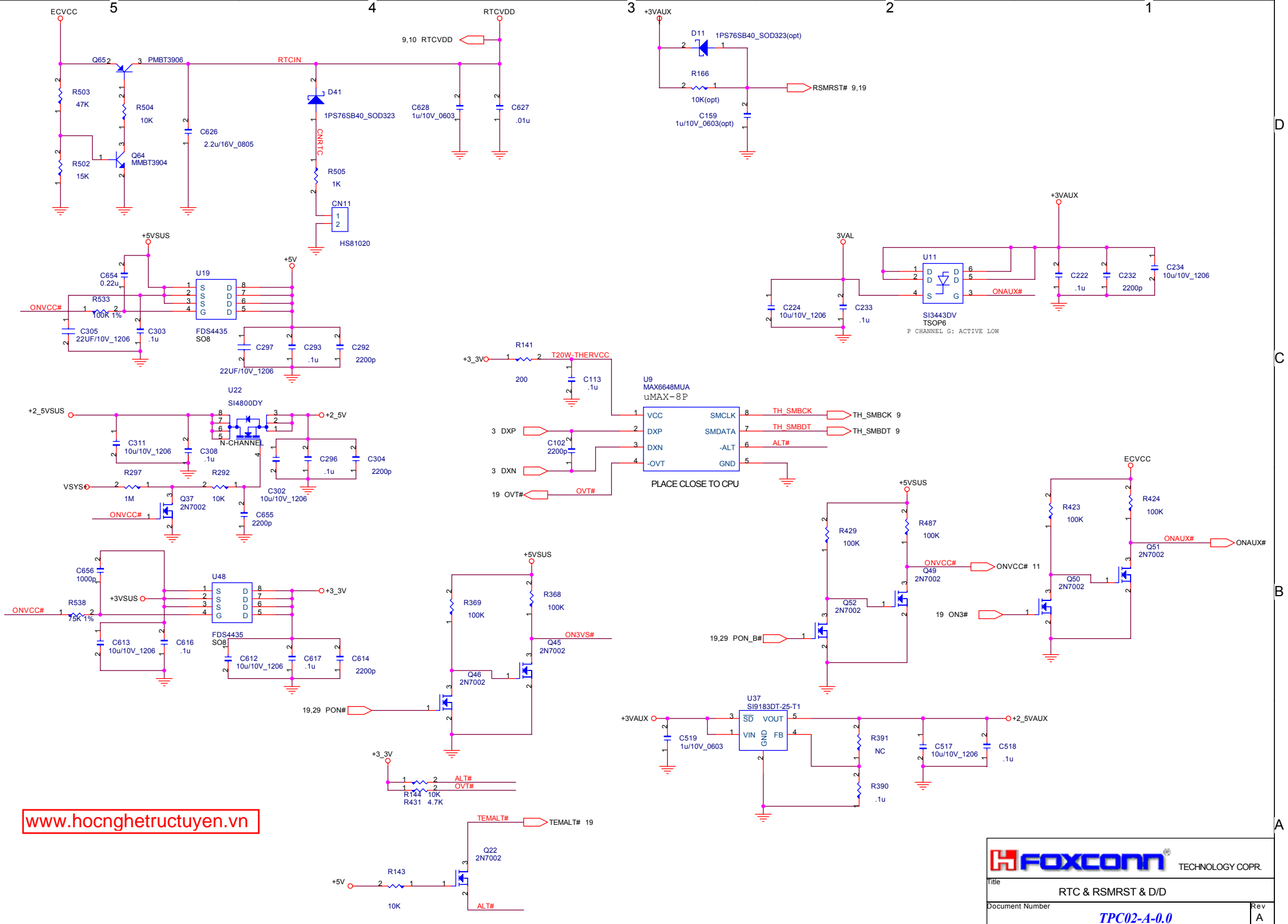

www.hocnghetructuyen.vn

FOXCONN TECHNOLOGY COPR.	
Title RTC & RSMRST & D/D	
Document Number	Rev A
TPC02-A-0.0	
Date: Sunday, February 01, 2004	Sheet 28 of 33

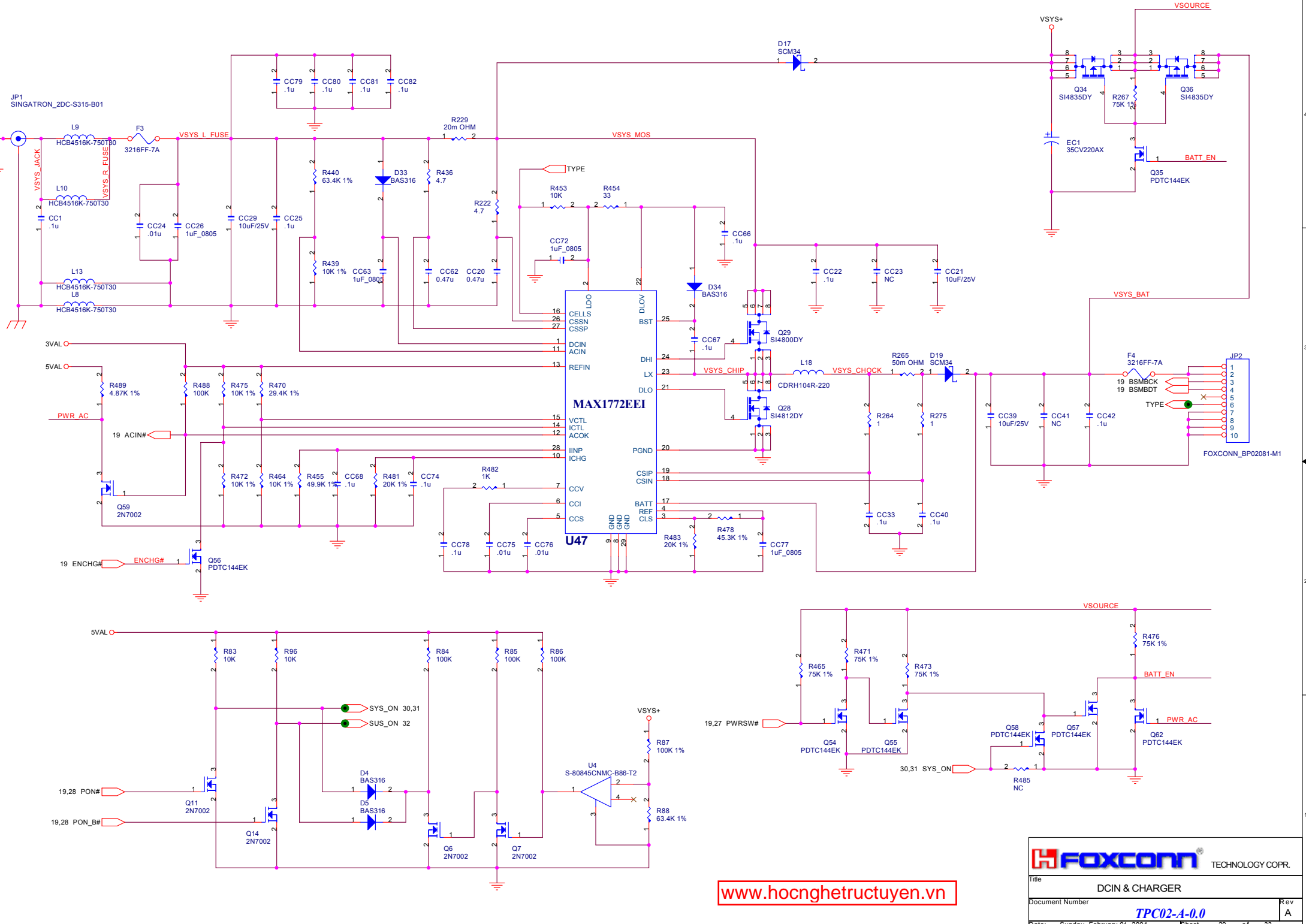

www.hocnghetructuyen.vn

www.hocnghetructuyen.vn

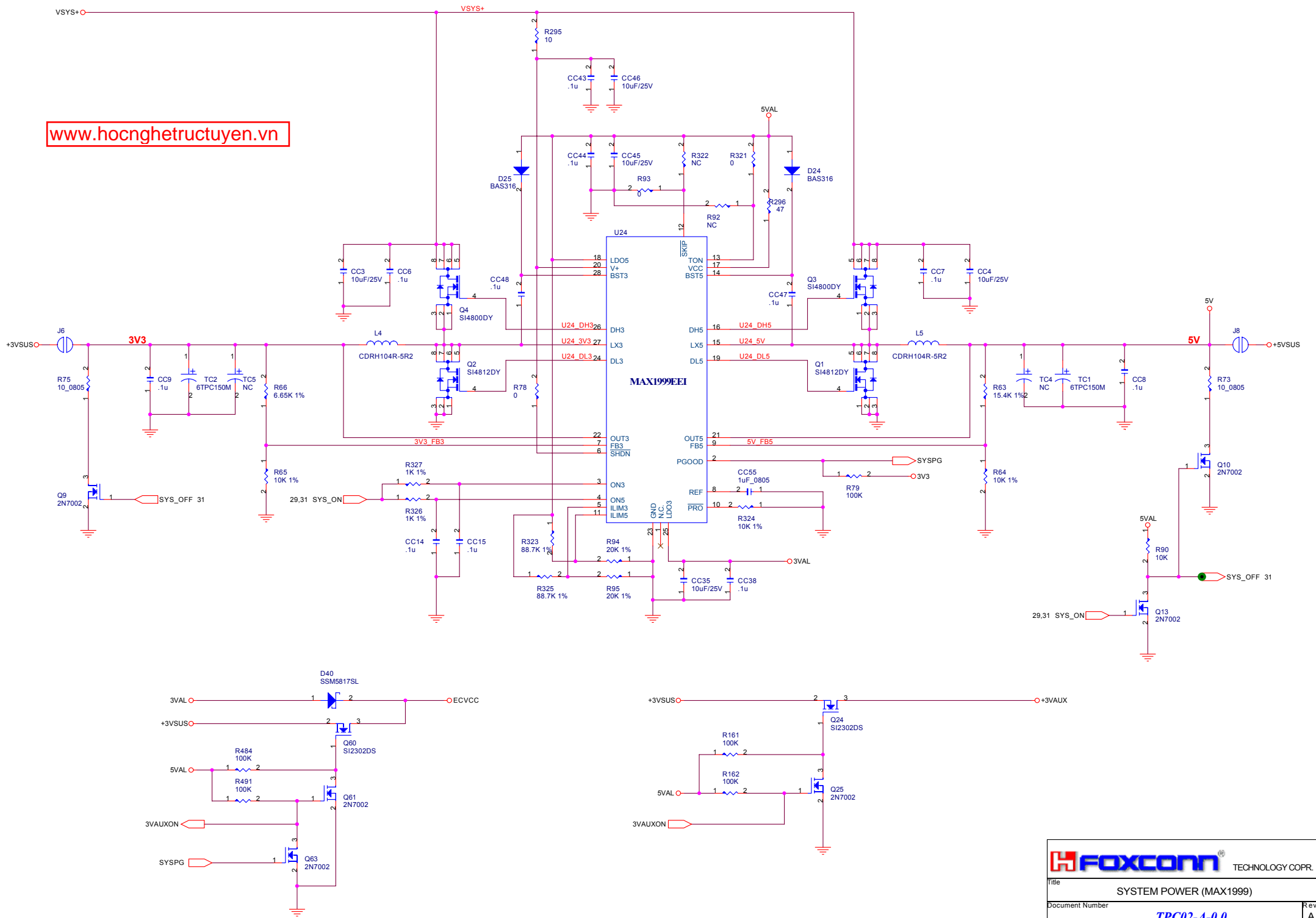

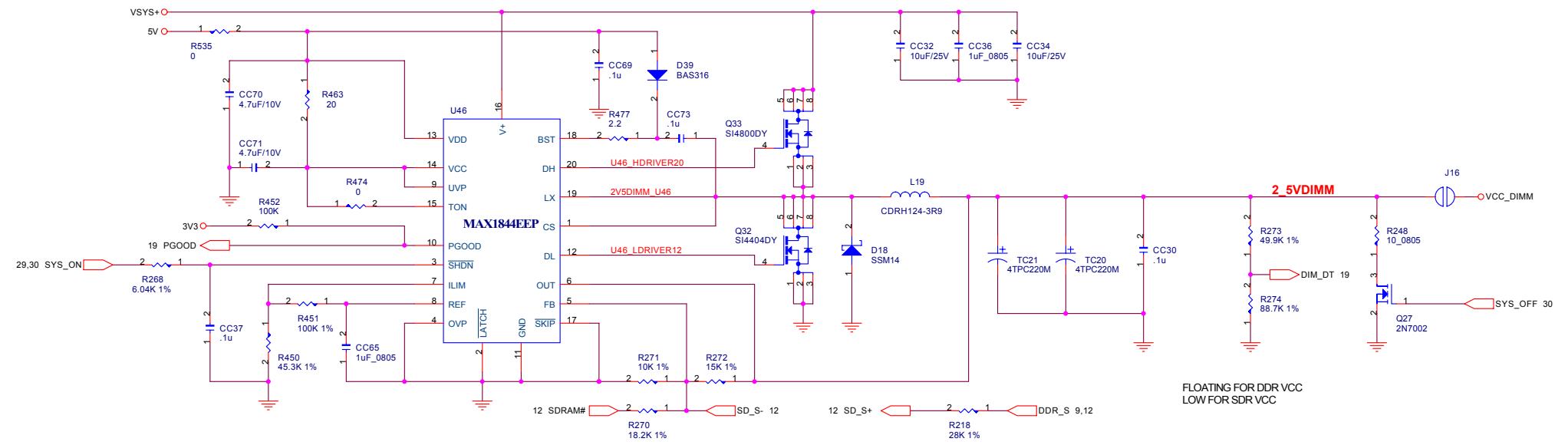
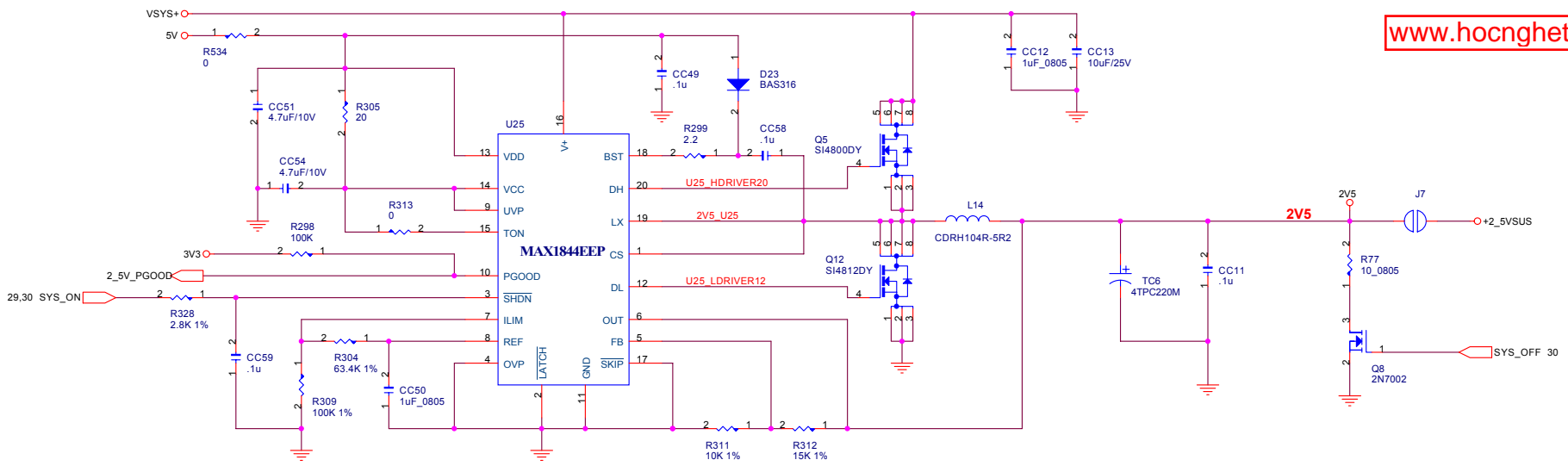

FLOATING FOR DDR VCC
LOW FOR SDR VCC

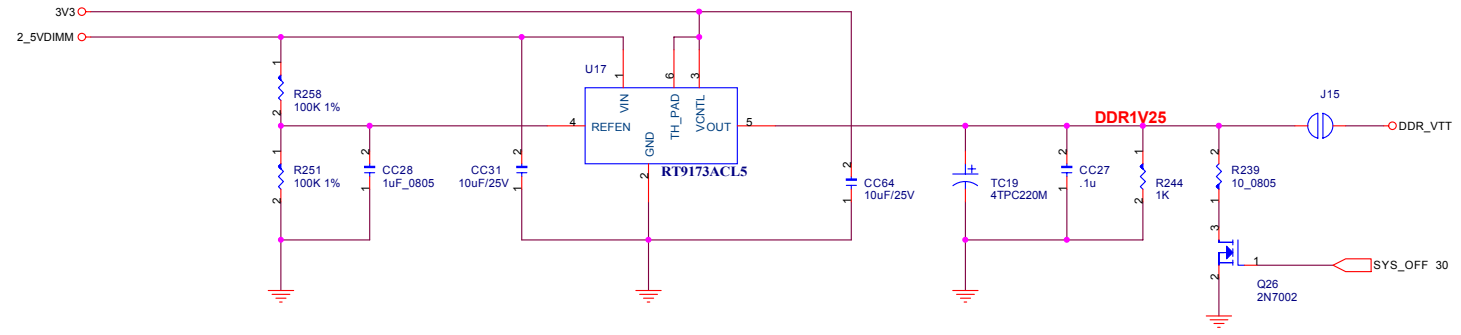

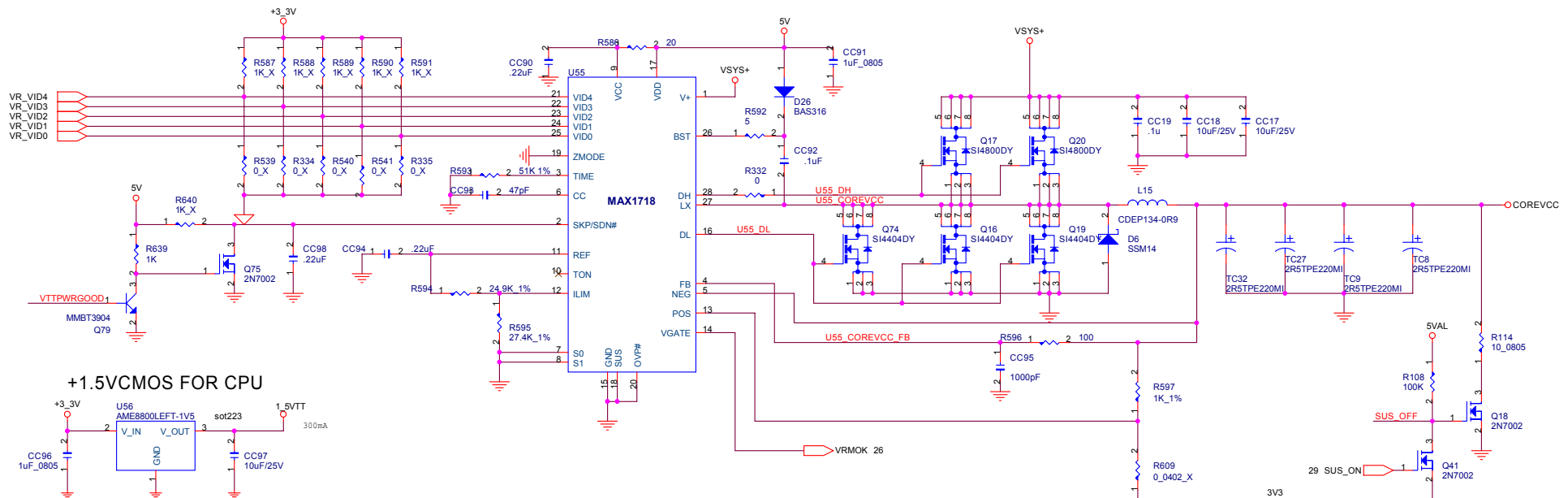

+1.5VCMOS FOR CPU

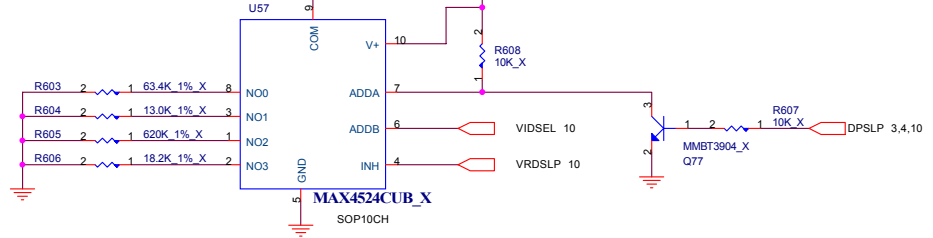
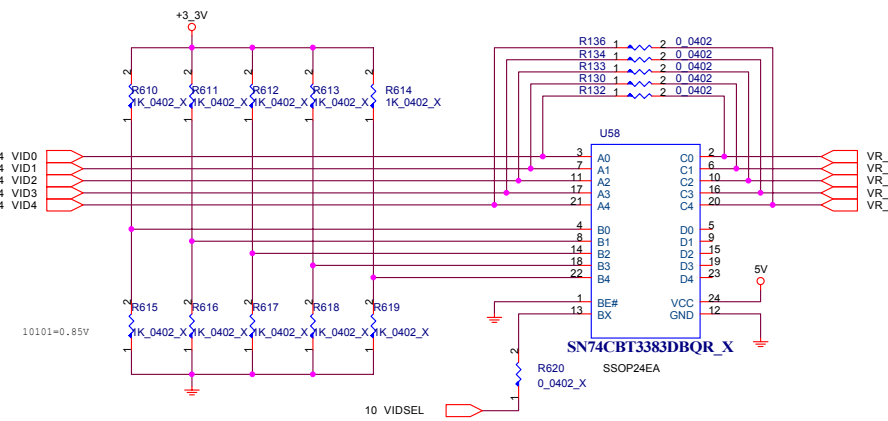
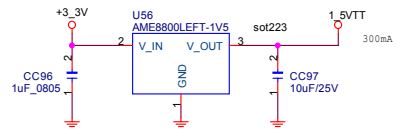

www.hocnghetructuyen.vn

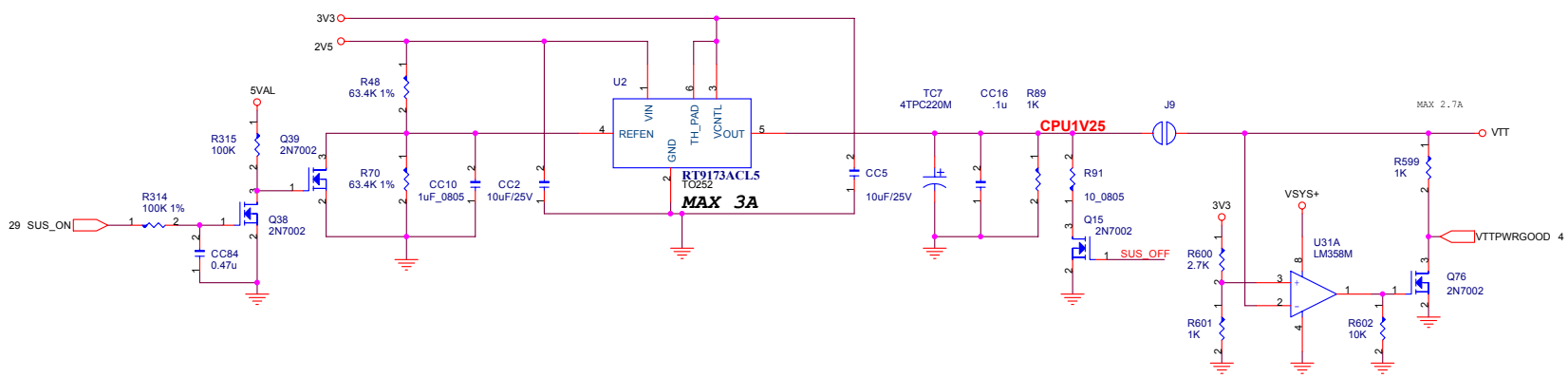

FOXCONN TECHNOLOGY CORP.

Title: CPU POWER

Document Number: TPC02-A-0.0

Date: Sunday, February 01, 2004

Sheet 32 of 33

Rev: A

www.hocnghetructuyen.vn

	
Title HISTROY	
Document Number <i>TPC02-A-0.0</i>	Rev A
Date: Sunday, February 01, 2004	Sheet 33 of 33