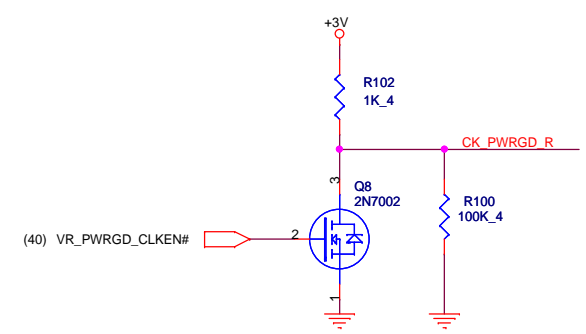
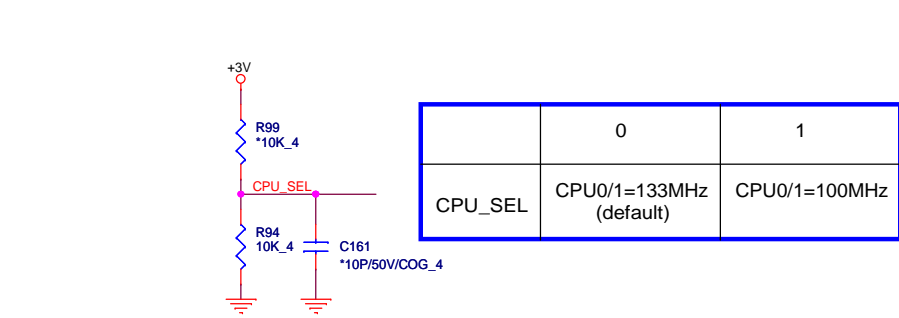
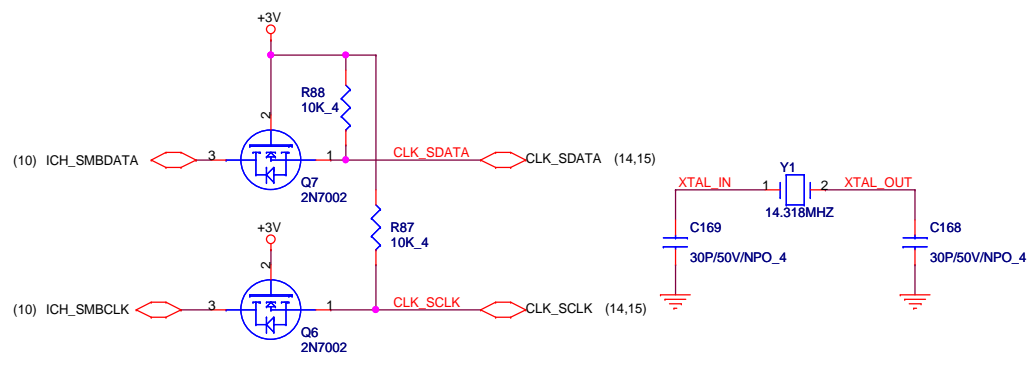
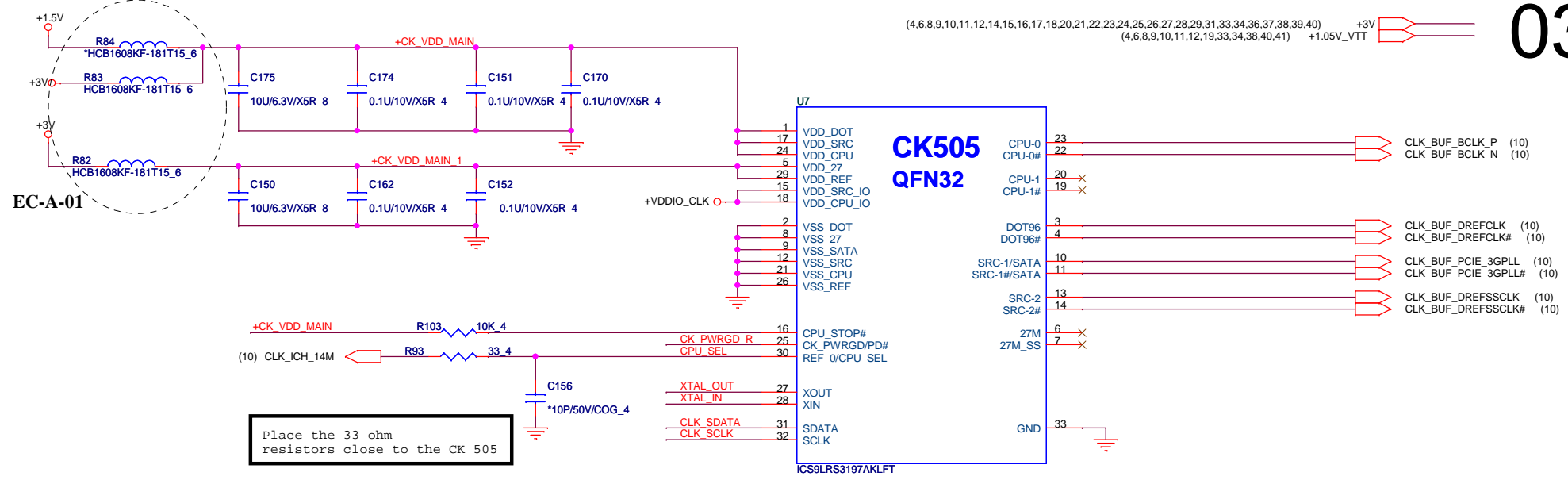

Table of Contents

PAGE	DESCRIPTION
1	Schematic Block Diagram
2	Front Page
3	CLOCK GENERATOR
4-7	Auburndale CPU
8-13	Ibex Peak-M
14-15	DDRIII SO-DIMM
16-22	Discreate VGA (M92-XT)
23	LCD + Camera Conn.
24	HDMI Conn.
25	CRT Conn.
26	Audio Codec ALC269
27	RTL8111DL
28	SATA HDD & ODD
29	USB x 2 & ESATA
30	USB X2/SIM_CARD/LEDs/RF
31	MINI-Card (UWB & WWAN)
32	MINI-Card (WLAN)
33	ONFI
34	Express Card
35	K/B & T/P
36	BLUETOOTH
37	FAN & Thermal
38	G-Sensor
39	B To B Conn.
40	iTPM & RFID EEPROM
41	KBC IT8502E
42	HOLD & SKEW
43	Discharge
44	Charger
45	DDR3 (TPS5116REGR)
46	1.05V_VTT & 1.05_PCH (RT8204)
47	3V/5V (MAX17101)
48	CPU (MAX17082)
49	DIS_GFX_VCC (MAX8792)
50	DIS_1.8V_RUN (OZ8116LN)
51	Power Block Dianram
52	XDP
53	Revision & Schematic Value Description
54	BOM Matrix Table

Power States

POWER PLANE	VOLTAGE	PAGE	DESCRIPTION	CONTROL SIGNAL	ACTIVE IN
VIN	10V~+20V	23,32,43,44,45,46,47,48,49,50	MAIN POWER		S0-S5
+3VRTC	+3.0V~+3.3V	9,12,41	RTC		S0-S5
3VPCU	+3.3V	9,23,27,30,32,35,39,41,43,44,47	ITE8052 POWER	3V5V_EN	S0-S5
5VPCU	+5V	14,43,44,45,46,47,49,50	DC/DC POWER IC SOURCE	3V5V_EN	S0-S5
+15V	+15V	23,38,43,45,46,47	LARGE POWER	3V5V_EN	S0-S5
LANVCC	+3.3V	27,43	LAN POWER	LAN_ON	
5V_S5	+5V	12,29,30,43	PCH SUS POWER	S5_ON	S0-S3
3V_S5	+3.3V	8,9,10,11,12,43,52	Sys Management,PCH Resume Well,Intel HD Audio,USB,WLAN WiMAX POWER	S5_ON	S0-S3
5VSUS	+5V	23,39,43,48	SLP_S4# CTRLD POWER	SUSON	S0-S3
3VSUS	+3.3V	14,15,30,34,41,43,49	SLP_S4# CTRLD POWER	SUSON	S0-S3
1.5VSUS	+1.5V	4,6,14,15,43,45,46,49,50	SODIMM POWER	SUSON	S0-S3
0.75VSMDDR_VTERM	+0.75V	14,15,43,45	DDR3 SODIMM REFERENCE POWER	MAIN_ON	S0
+5V	+5V	12,18,23,24,25,26,28,35,37,41,43,44	SLP_S3# CTRLD POWER	MAIN_ON	S0
+3V	+3.3V	3,4,8,9,10,11,12,14,15,17,23,25,26,27,28,29,30,31,32,33,34,36,37,38,39,40,41,43,44,45,46,47,48,50,52	SLP_S3# CTRLD POWER	MAIN_ON	S0
+1.8V	+1.8V	6,12,17,18,21,22,33,43,50	LVDS,NVM POWER	MAIN_ON	S0
+1.5V	+1.5V	12,18,19,20,31,32,34,45,46	Mini PCIe,Express Card POWER	MAIN_ON	S0
+1.05V_VTT	+1.05V	4,6,11,12,43,46,48,52	AuBurndale VTT POWER	MAIN_ON	S0
+1.05V_PCH	+1.05V	3,10,12,43,46,52	PCH CORE POWER	1.05V_RUN_ON	S0
+VCC_GFX_CORE	+0.9V~+1.2V	18,21,43,49	VGA CORE POWER	GFXVR_EN	S0
VCC_CORE		6,43,48	CPU CORE POWER	VRON	S0
LCDVCC	+3.3V	23	LCD Power	ENVDD	S0
+5V_ODD	+5V	28	ODD Power	MAIN_ON	S0
+5V_HDD	+5V	28	HDD Power	MAIN_ON	S0
BAT-V	+10V~+17V	44	MAIN BATTERY	CHG_PBATT	S0-S5



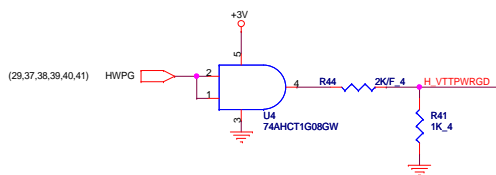
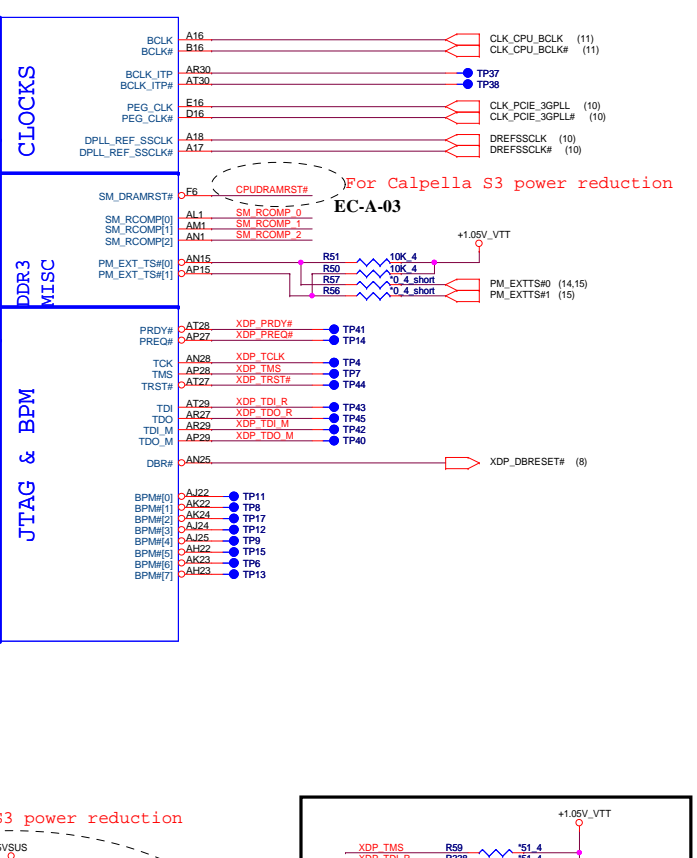
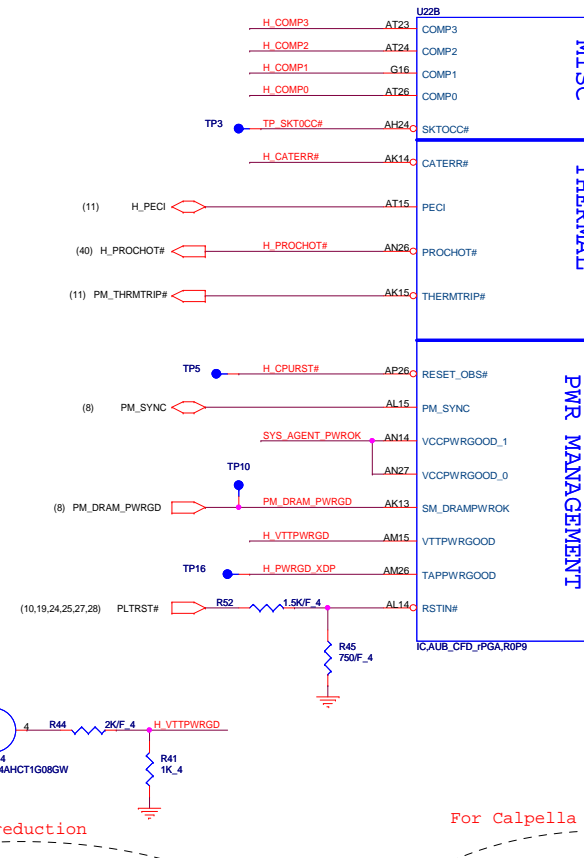
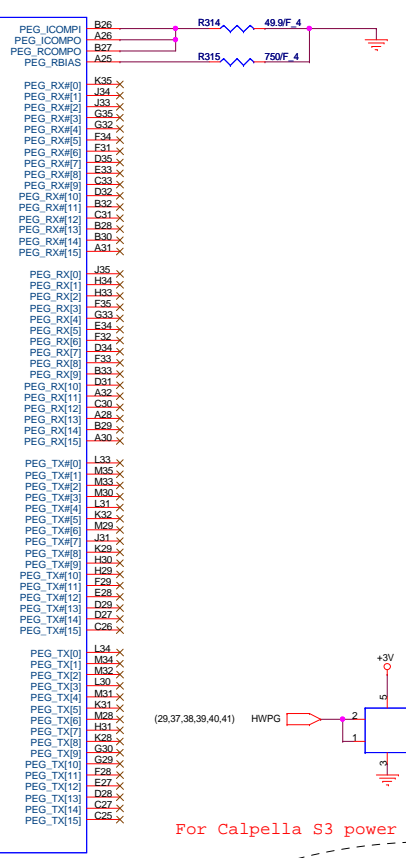
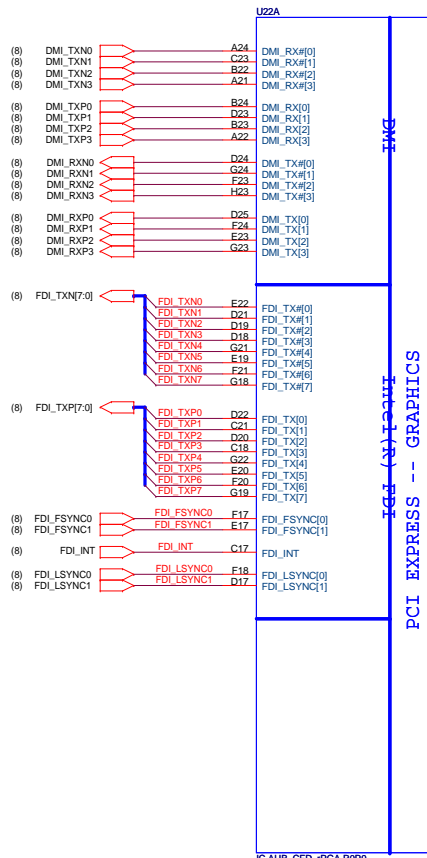

For Calpella S3 power reduction

For Calpella S3 power reduction

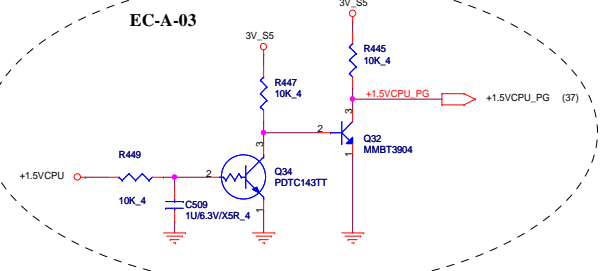
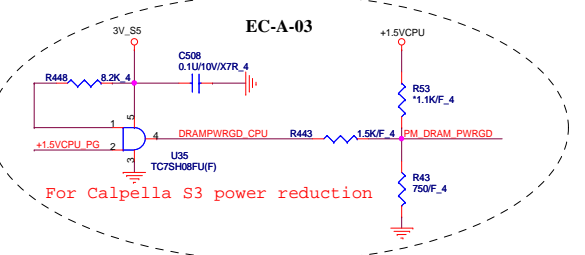

For Calpella S3 power reduction

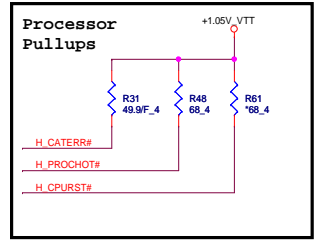
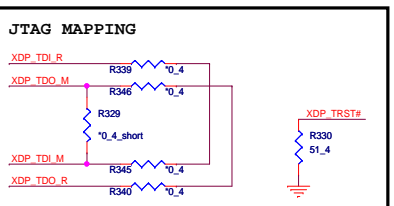
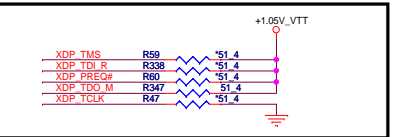
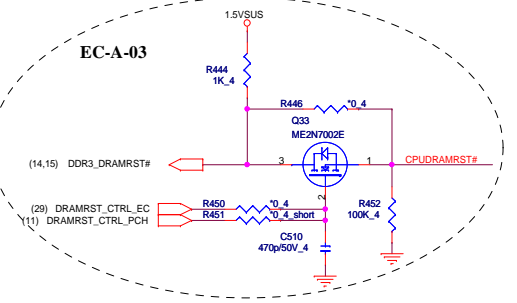

(8,40) DELAY_VR_PWRGOOD
 (11) H_PWRGOOD

Platform	ERB	CRB
REFDES	STUFF	NO_STUFF
R80	STUFF	NO_STUFF
R84	NO_STUFF	STUFF

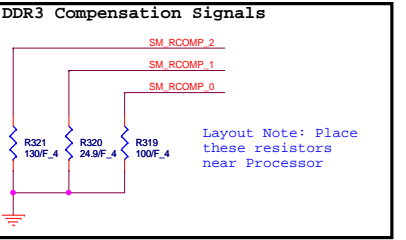
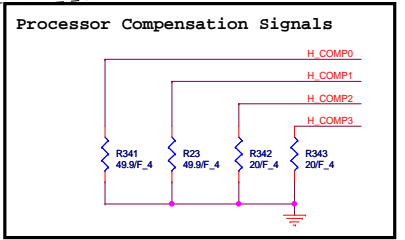

Scan Chain (Default)	STUFF -> R421, R411, R422 NO STUFF -> R430, R429
CPU Only	STUFF -> R421, R430 NO STUFF -> R411, R429, R422
GMCH Only	STUFF -> R429, R422 NO STUFF -> R421, R430, R411

AUBURNDALE PROCESSOR (DDR3)

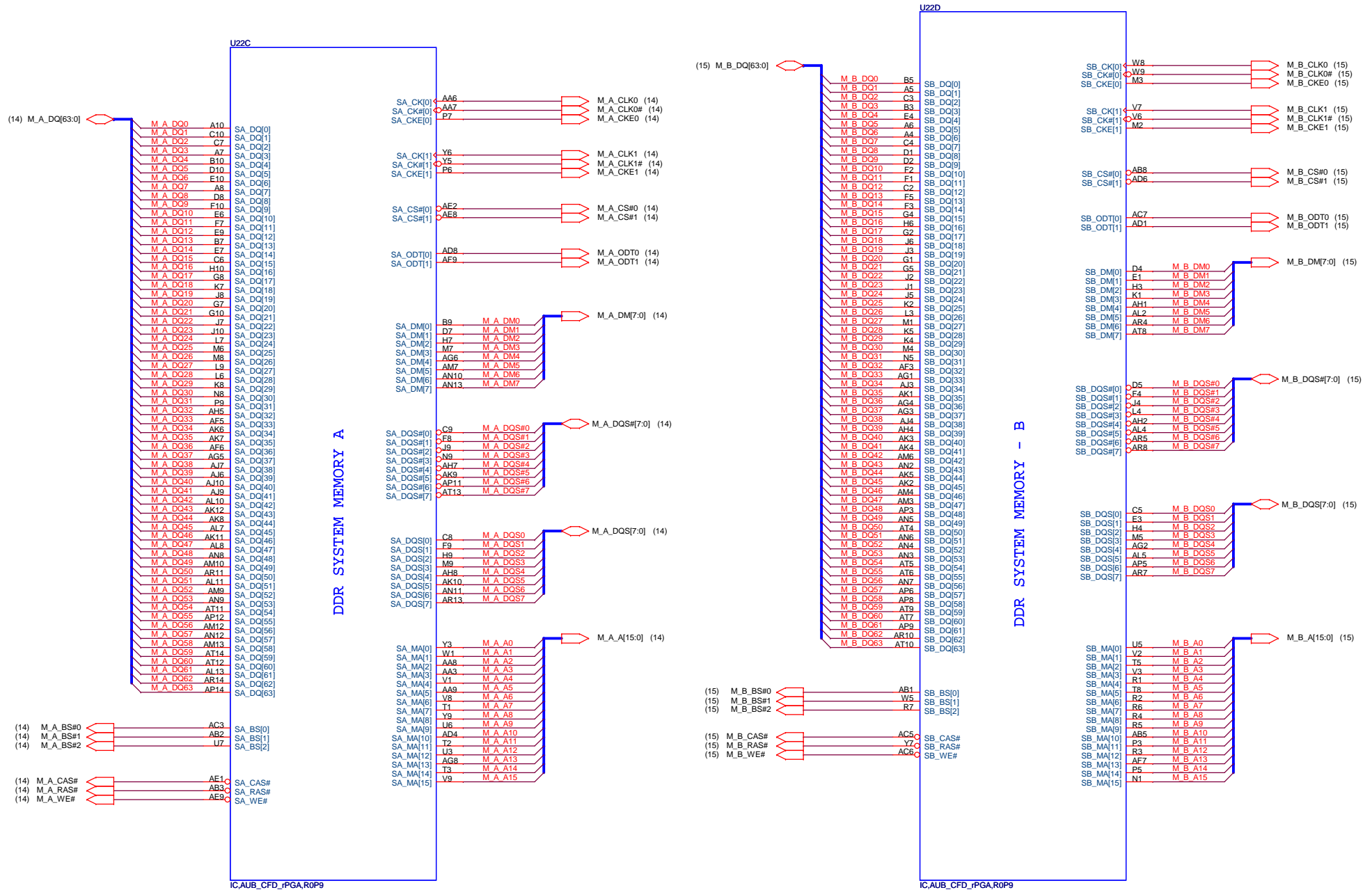

(3,4,8,9,10,11,12,19,33,34,38,40,41) +1.8V_VTT
(6,34,37) +1.8V_CPU
(10,12,33,34,41) +1.8V

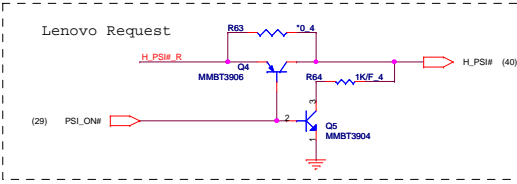
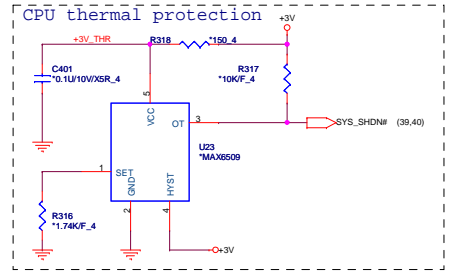
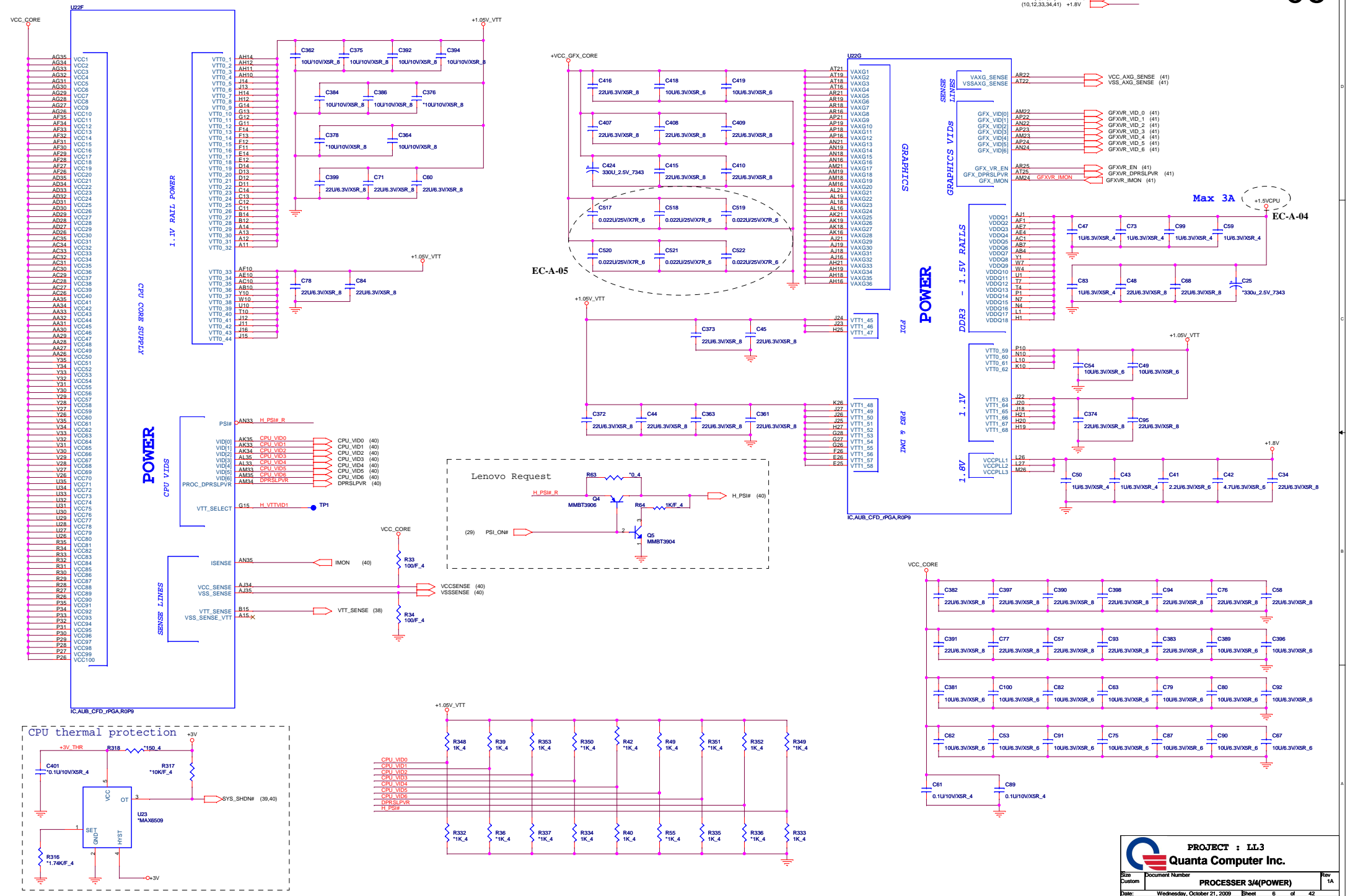

AUBURNDALE PROCESSOR (GND)

AUBURNDALE PROCESSOR(RESERVED, CFG)

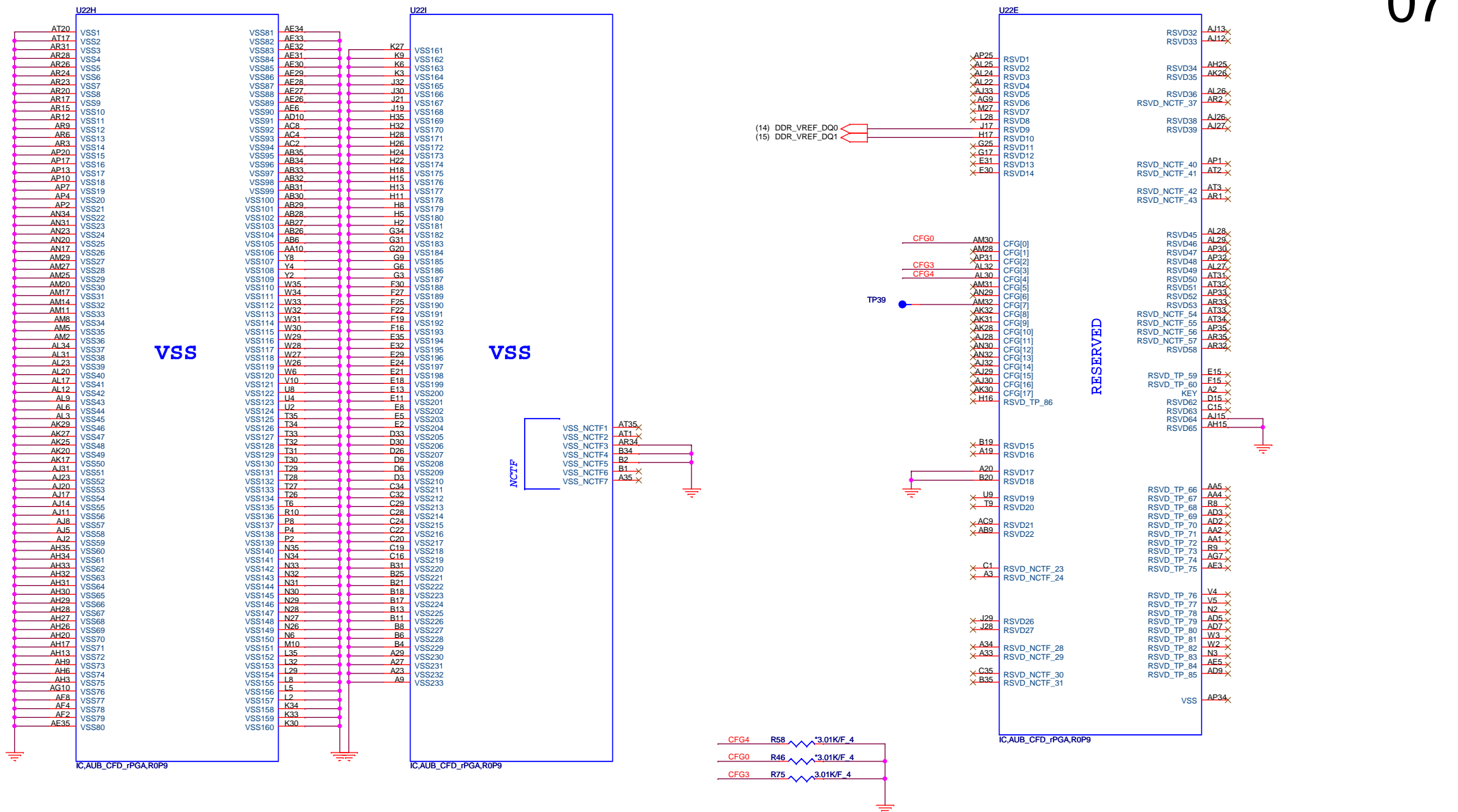

PROJECT : LL3
Quanta Computer Inc.

Size Custom Document Number **PROCESSOR 4/4(GND)** Rev 1A

Date: Wednesday, October 21, 2009 Sheet 7 of 42

IBEX PEAK-M (DMI, FDI, GPIO)

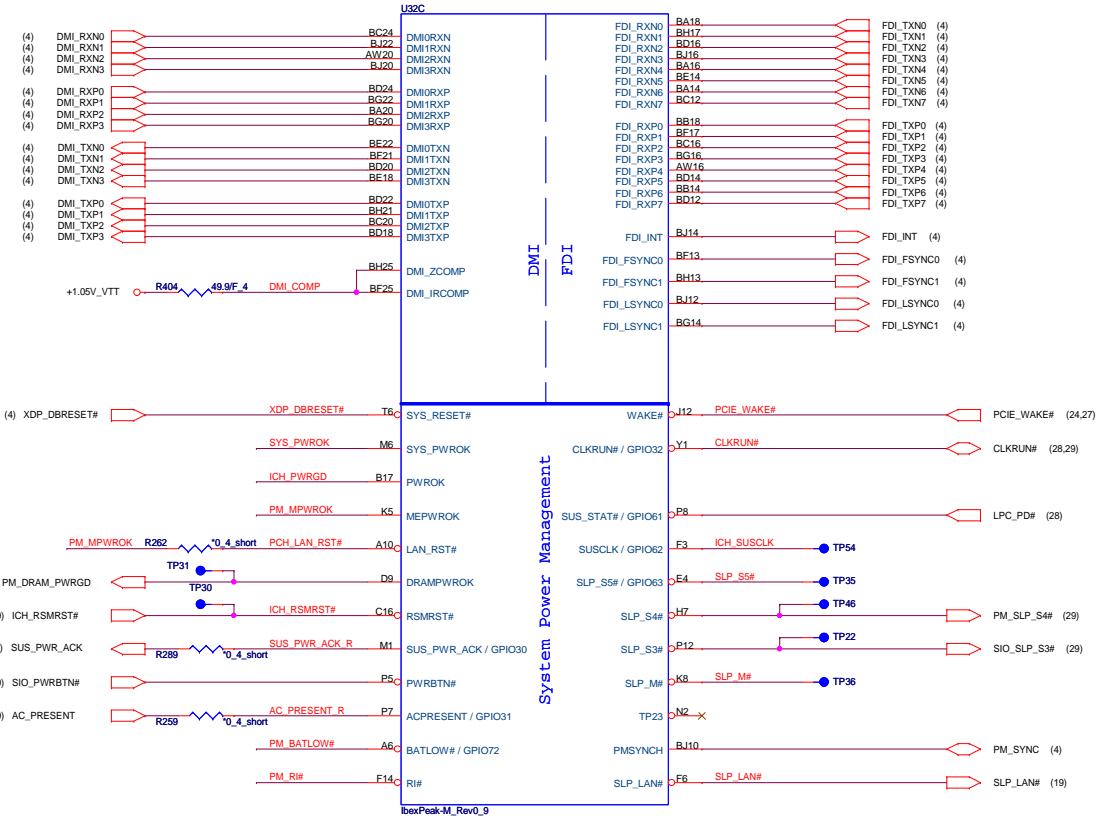

IBEX PEAK-M (LVDS, DDI)

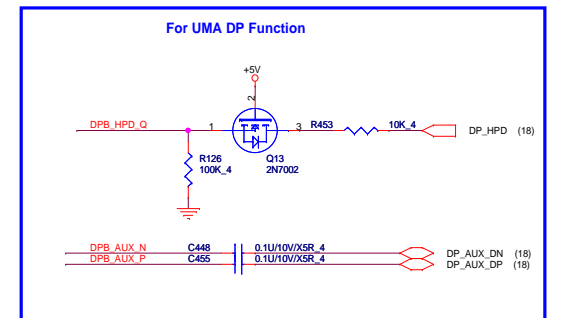
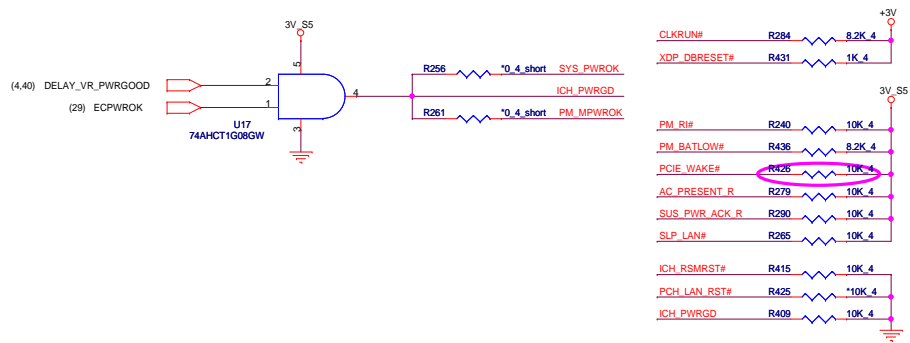
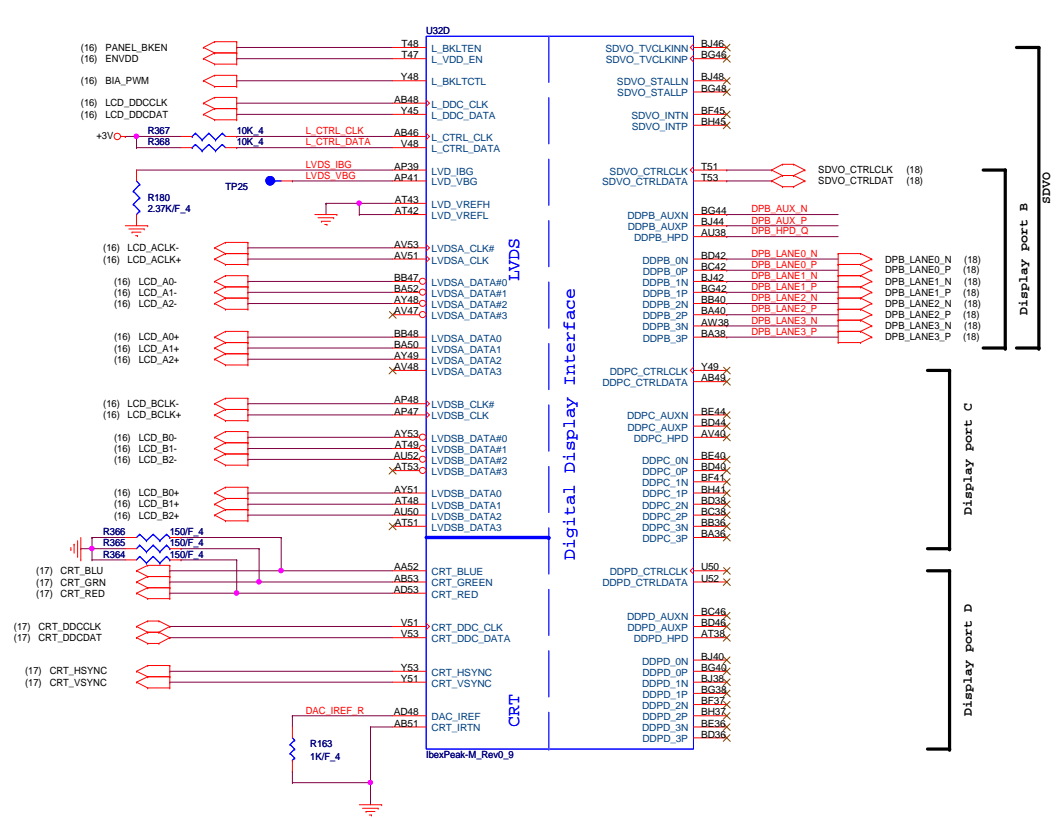

RTC Circuitry

CMOS Settings		J5
Clear CMOS		1-2
Save CMOS		1-X (Default)

TPM Settings		J4
Clear ME RTC registers		1-2
Save ME RTC registers		1-X (Default)

INTVRMEN - Integrated SUS 1.1V VRM Enable
 High - Enable Internal VRs

IBEX PEAK-M (HDA, JTAG, SATA)

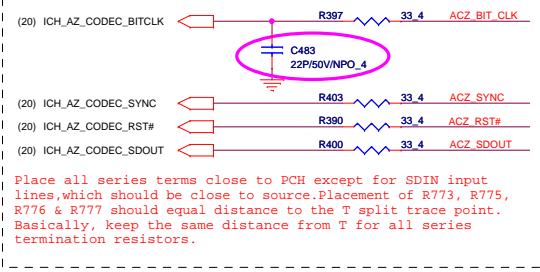
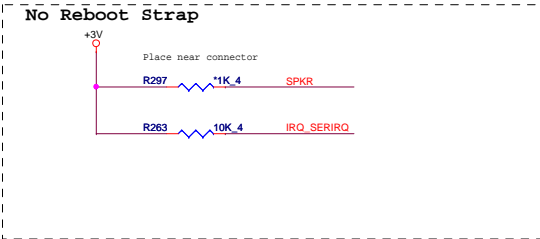
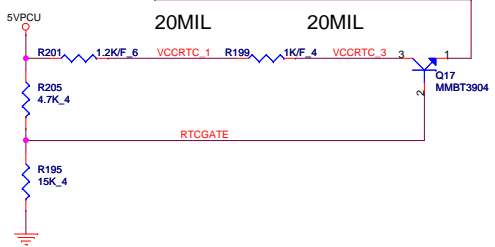
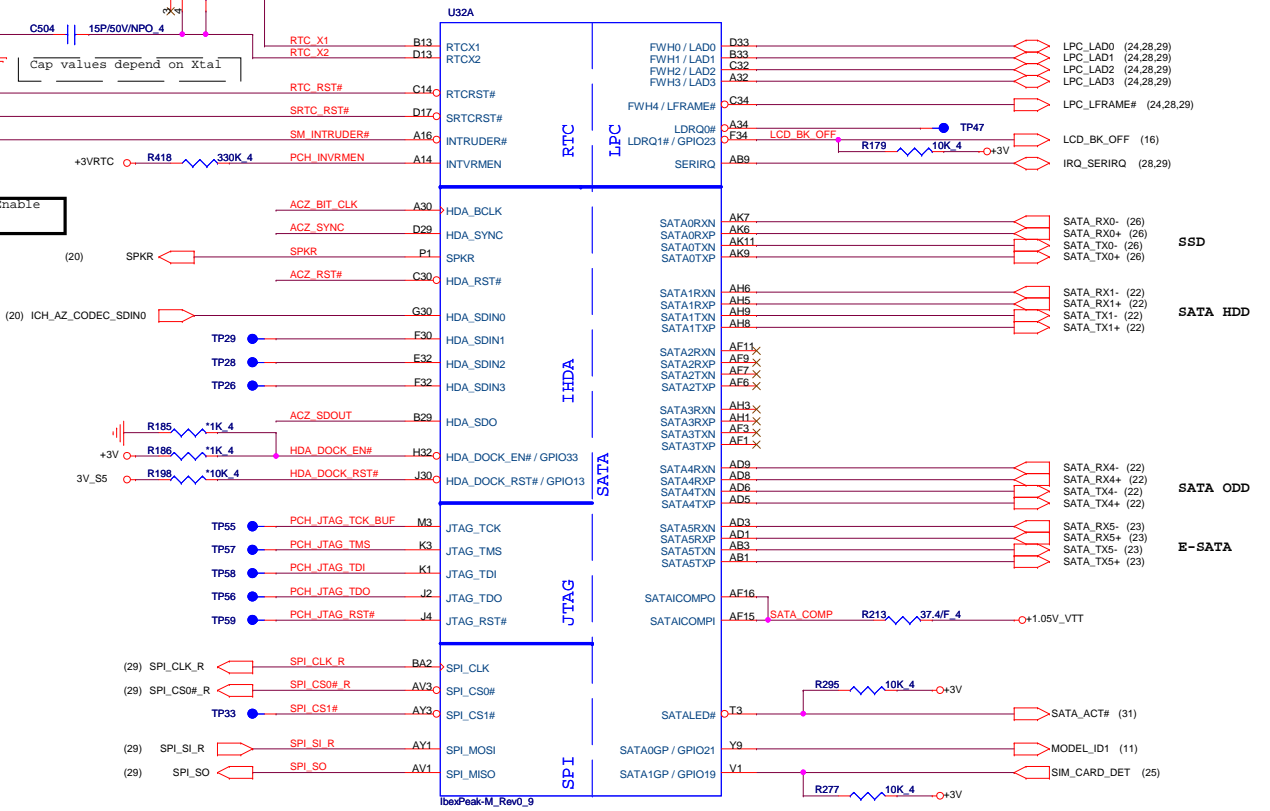

iTPM ENABLE/DISABLE

TPM Function	R292
Enable	Stuff
Disable	NC (Default)

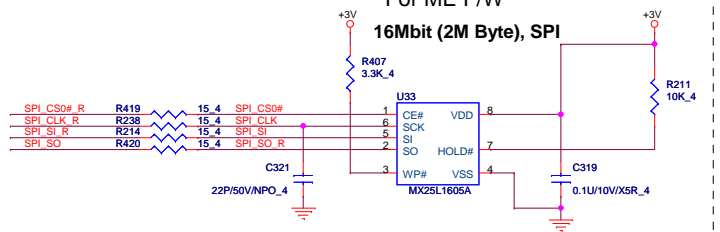

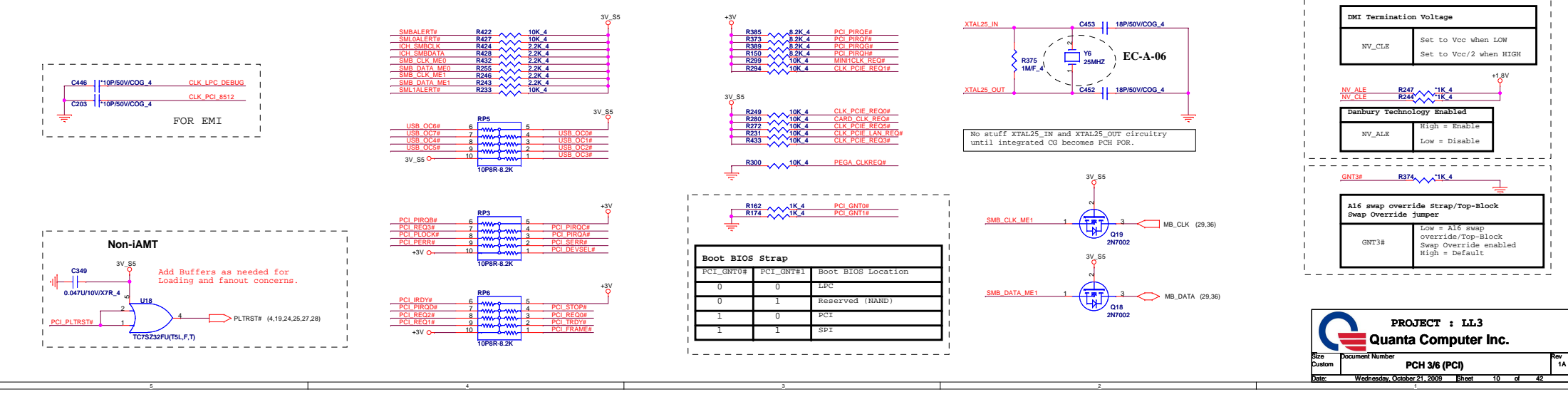
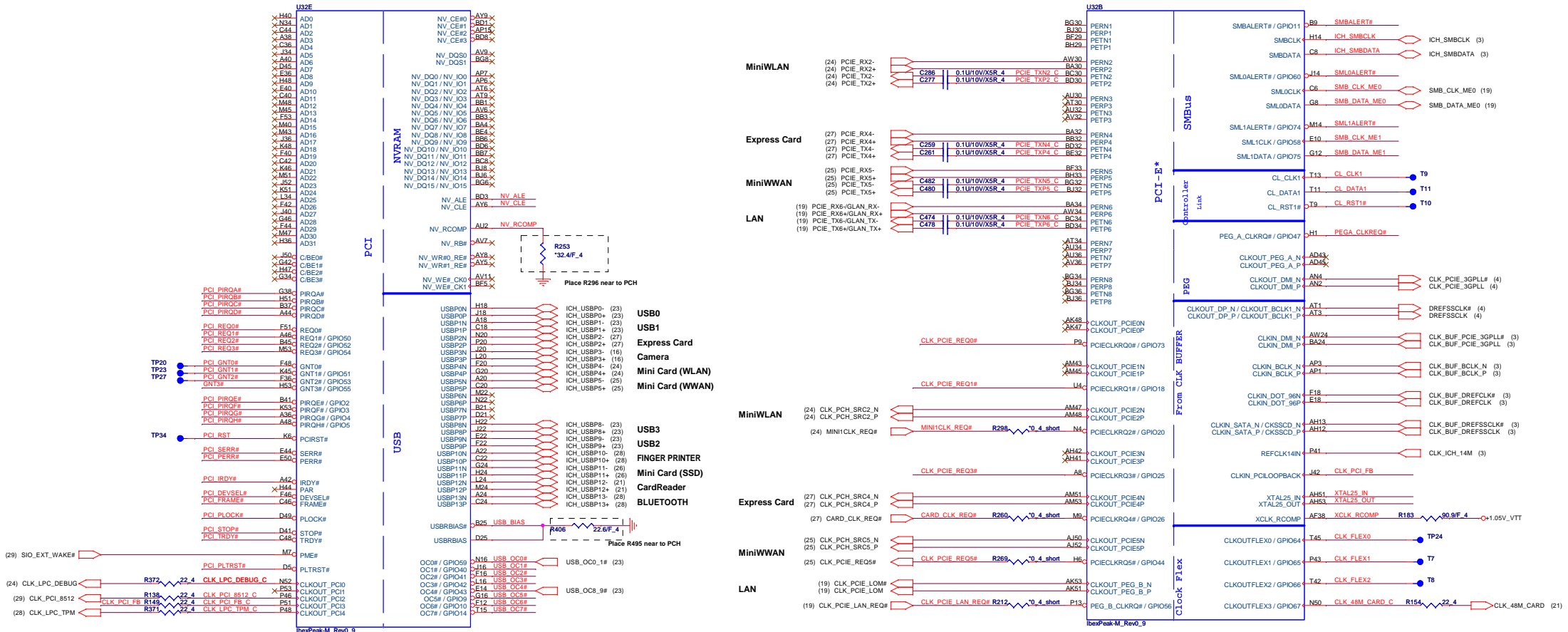

IBEX PEAK-M (GPIO,VSS_NCTF,RSVD)

(3,4,6,8,9,10,12,14,15,16,17,18,20,21,22,23,24,25,26,27,28,29,31,33,34,36,37,38,39,40)
 (4,8,9,10,12,19,24,33,34)
 (3,4,6,8,9,10,12,19,33,34,38,40,41)

+3V
 3V_SS
 +1.05V_VTT

11

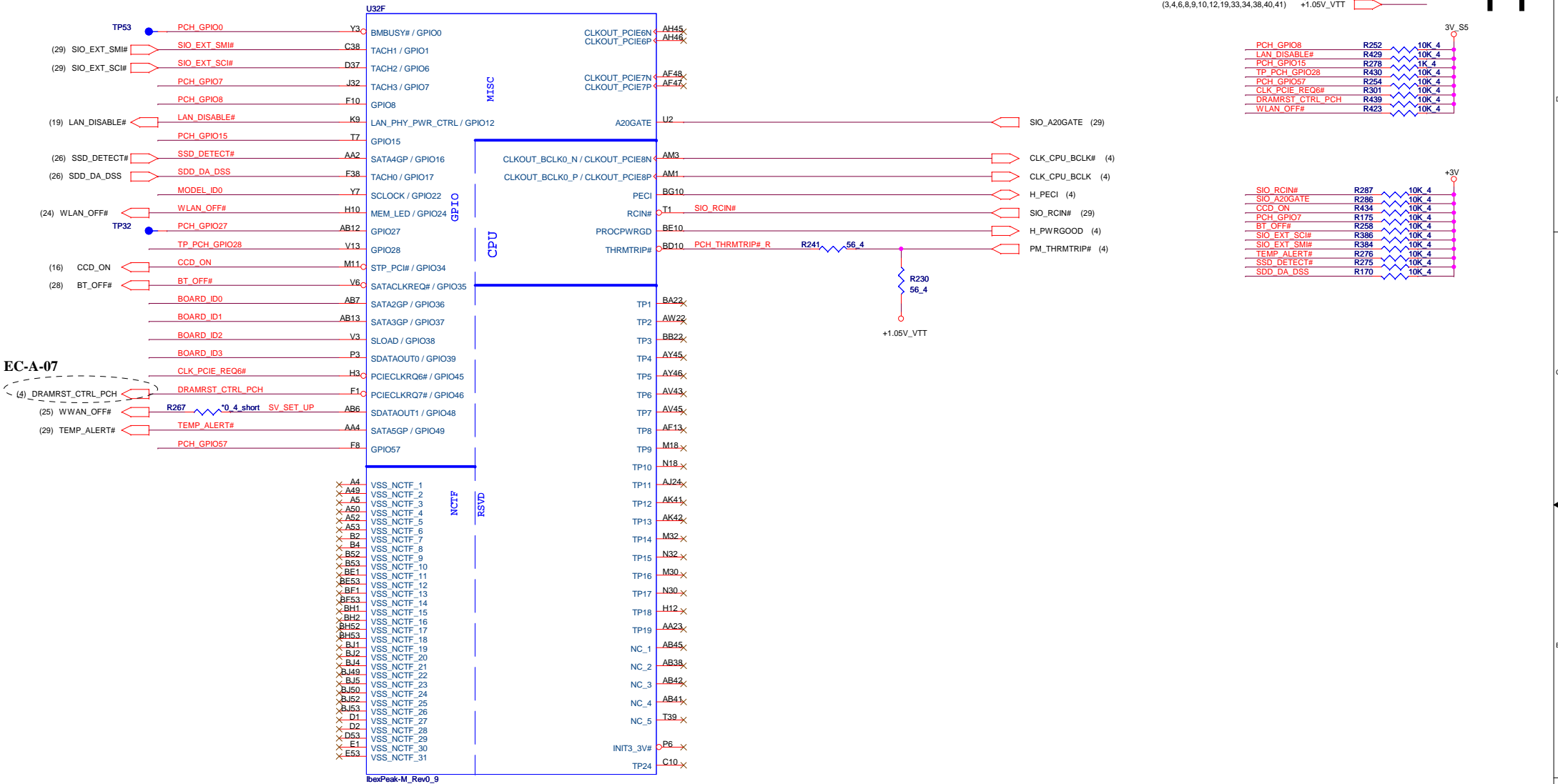

EC-A-07

Board ID

Board ID For Function	ID3 GPIO39	ID2 GPIO38	ID1 GPIO37	ID0 GPIO36
SDV	0	0	0	0
SIV	0	0	0	1
SIT	0	0	1	0
SVT	0	0	1	1
SOVP	0	1	0	0

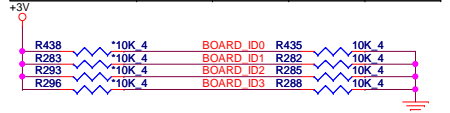

Model ID

Model ID	MODEL_ID0	MODEL_ID1
LL3/LL3A	0	0
LL5/LL5A	0	1
	1	0
	1	1

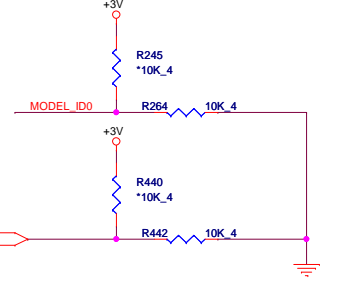

SV_SET_UP 1-X High = Strong (Default)

PROJECT : LL3
Quanta Computer Inc.

Size Custom Document Number **PCH 4/6 (GPIO)** Rev 1A

Date: Wednesday, October 21, 2009 Sheet 11 of 42

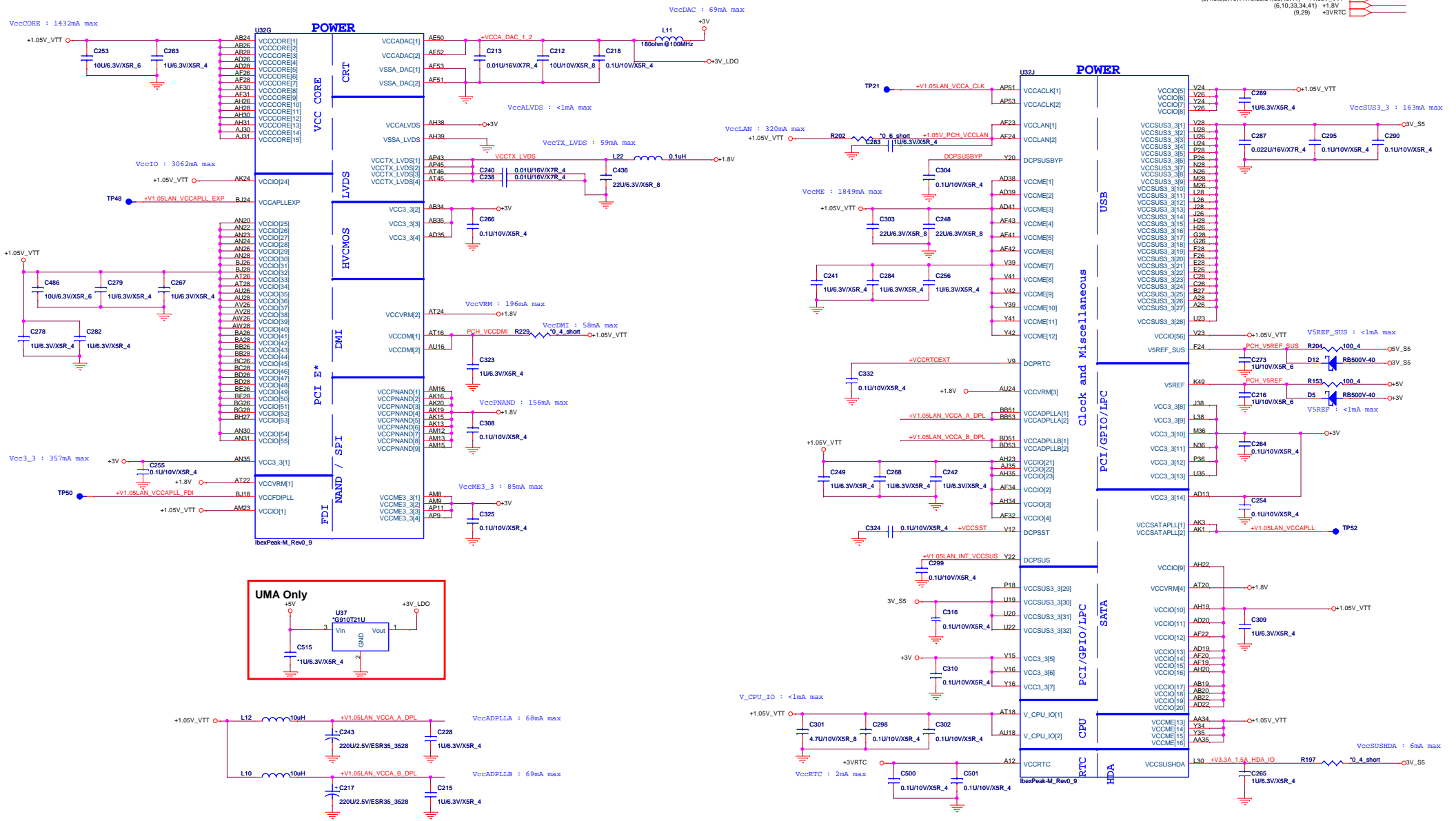

IBEX PEAK-M (GND)

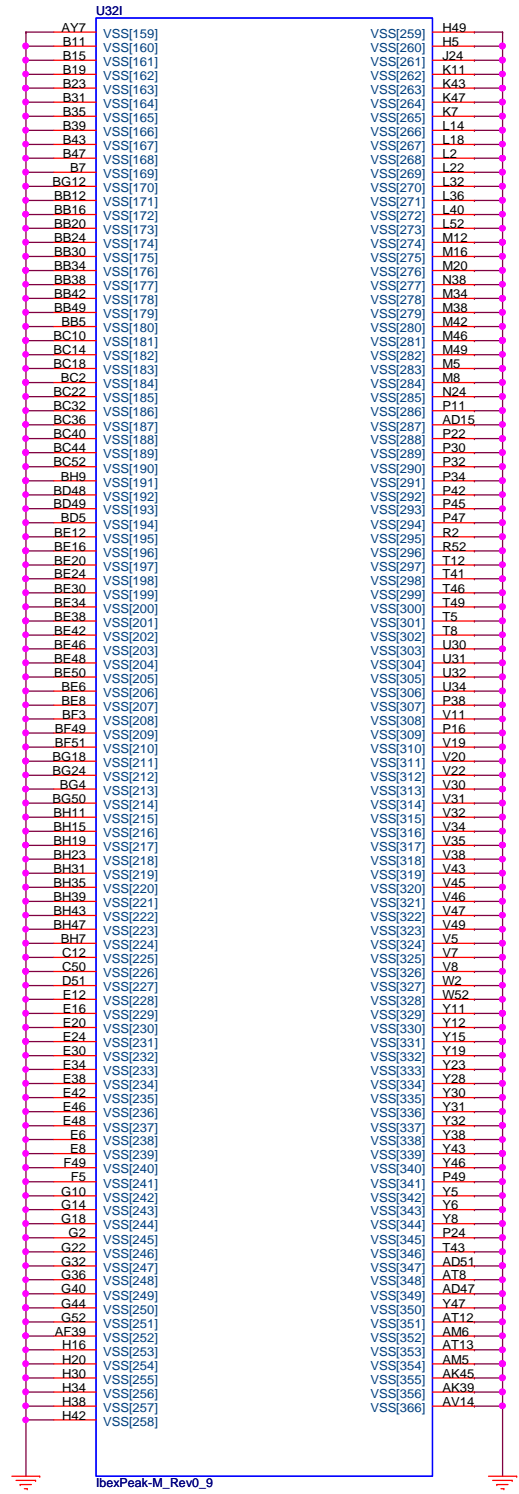
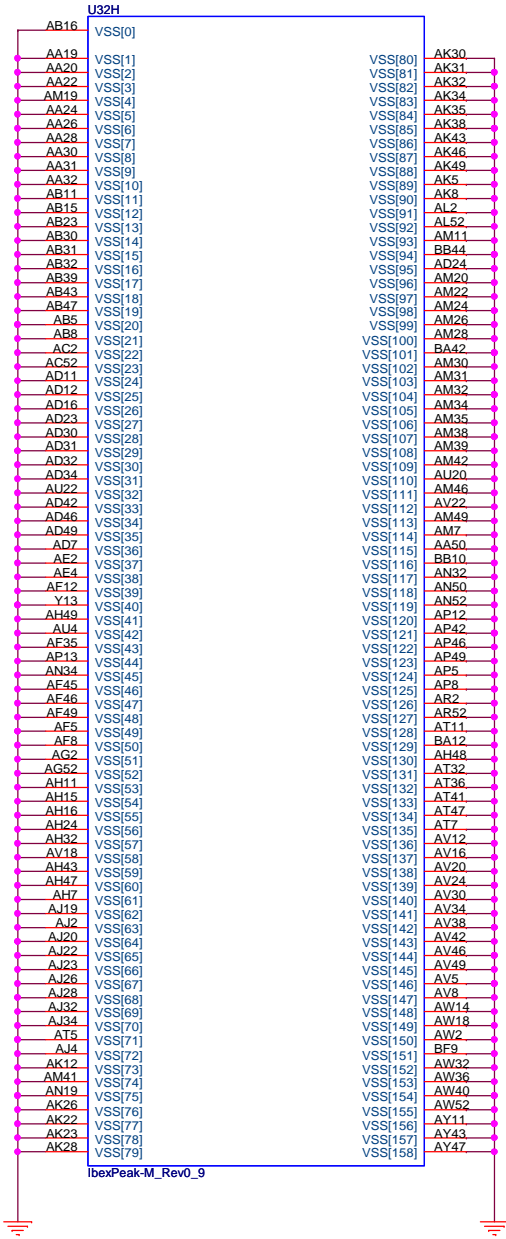

PROJECT : LL3
Quanta Computer Inc.

Size Custom Document Number **PCH 6/6 (GND)** Rev 1A

Date: Wednesday, October 21, 2009 Sheet 13 of 42

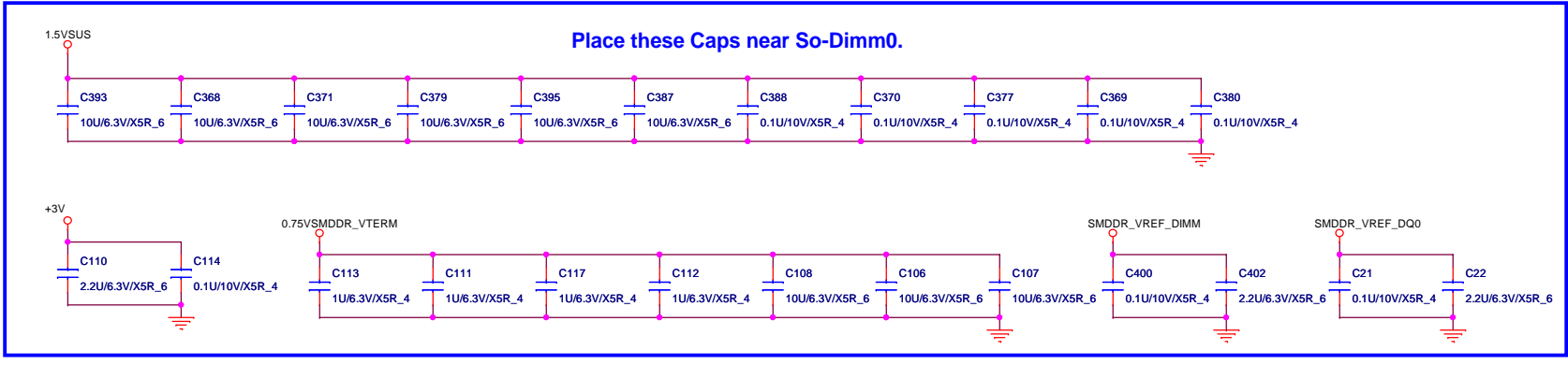
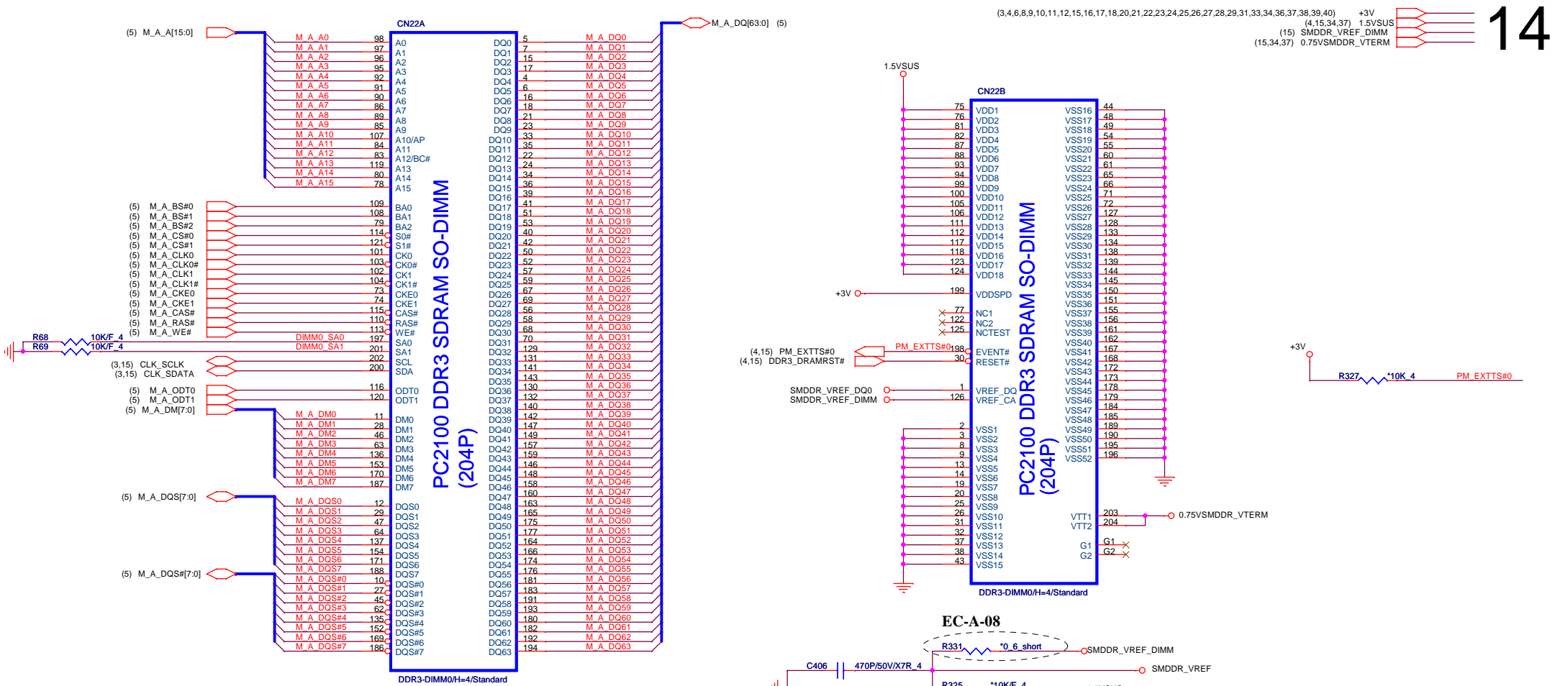

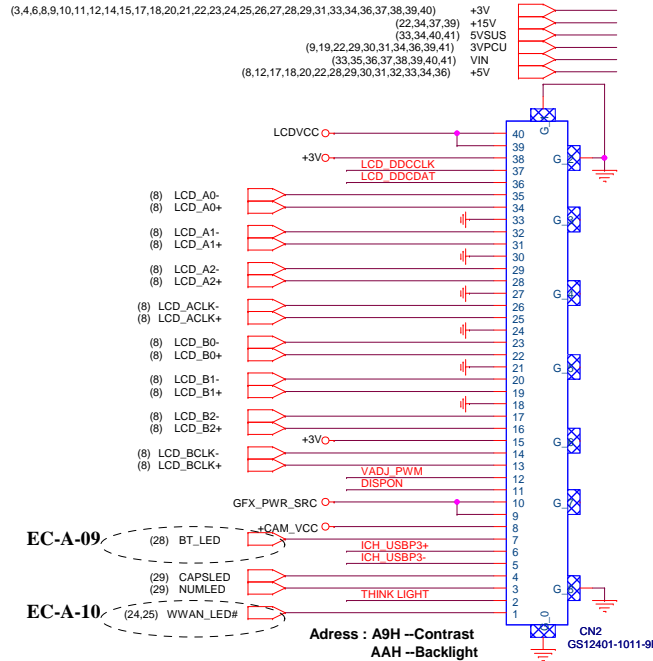
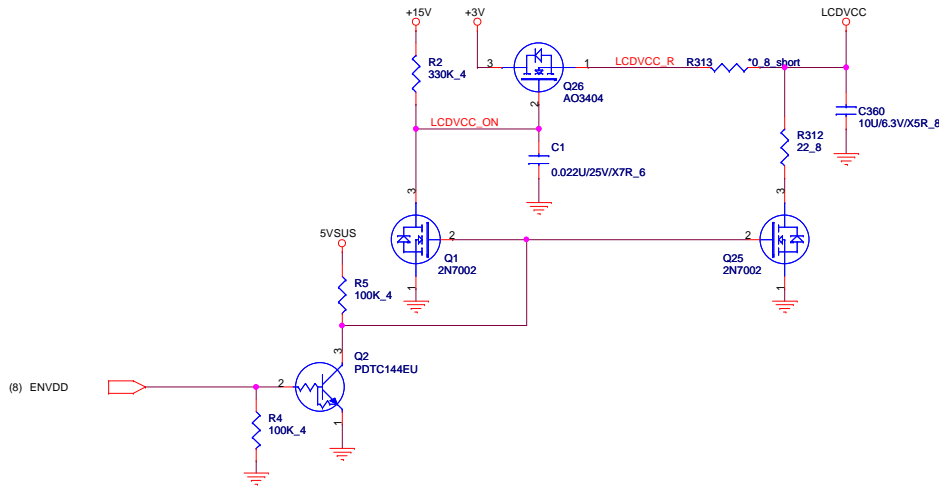

back light

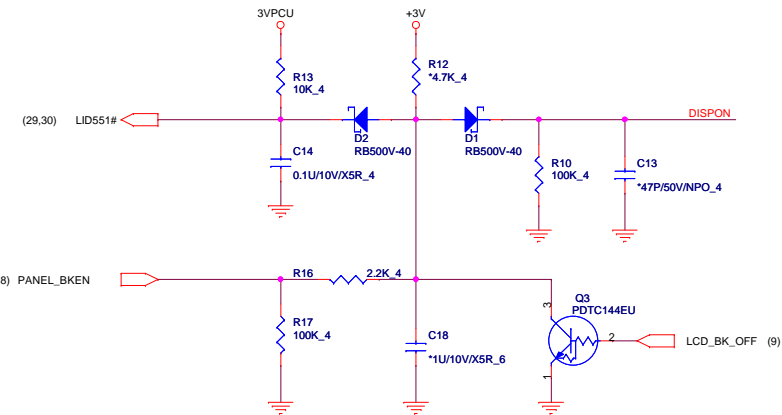

THINK LIGHT LED ON

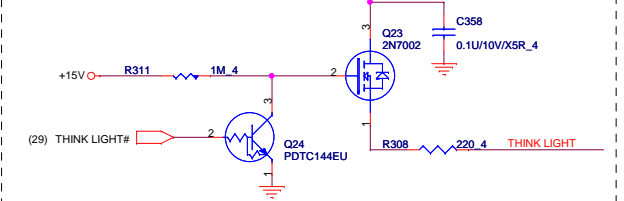

CAMERA VCC Control

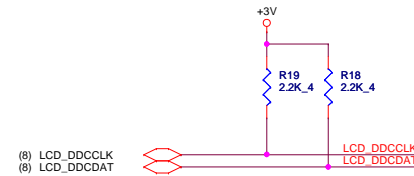
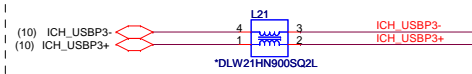
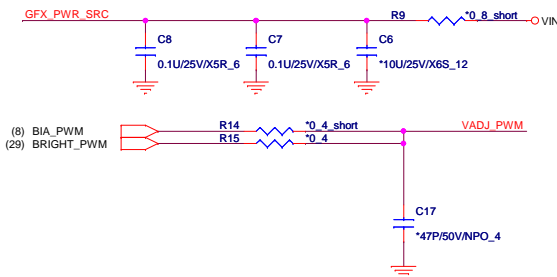
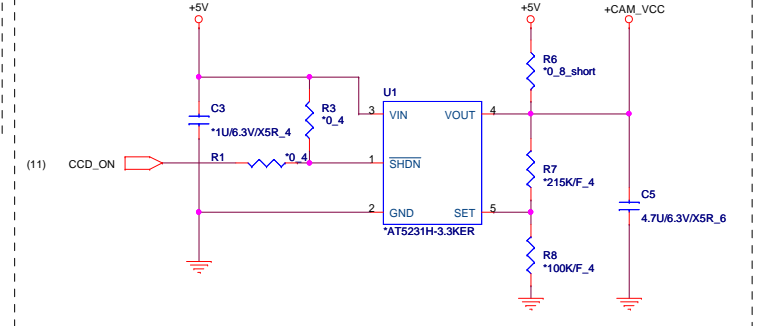

Layout Note:
Setting R,G,B trace
impedance to 50 ohm.

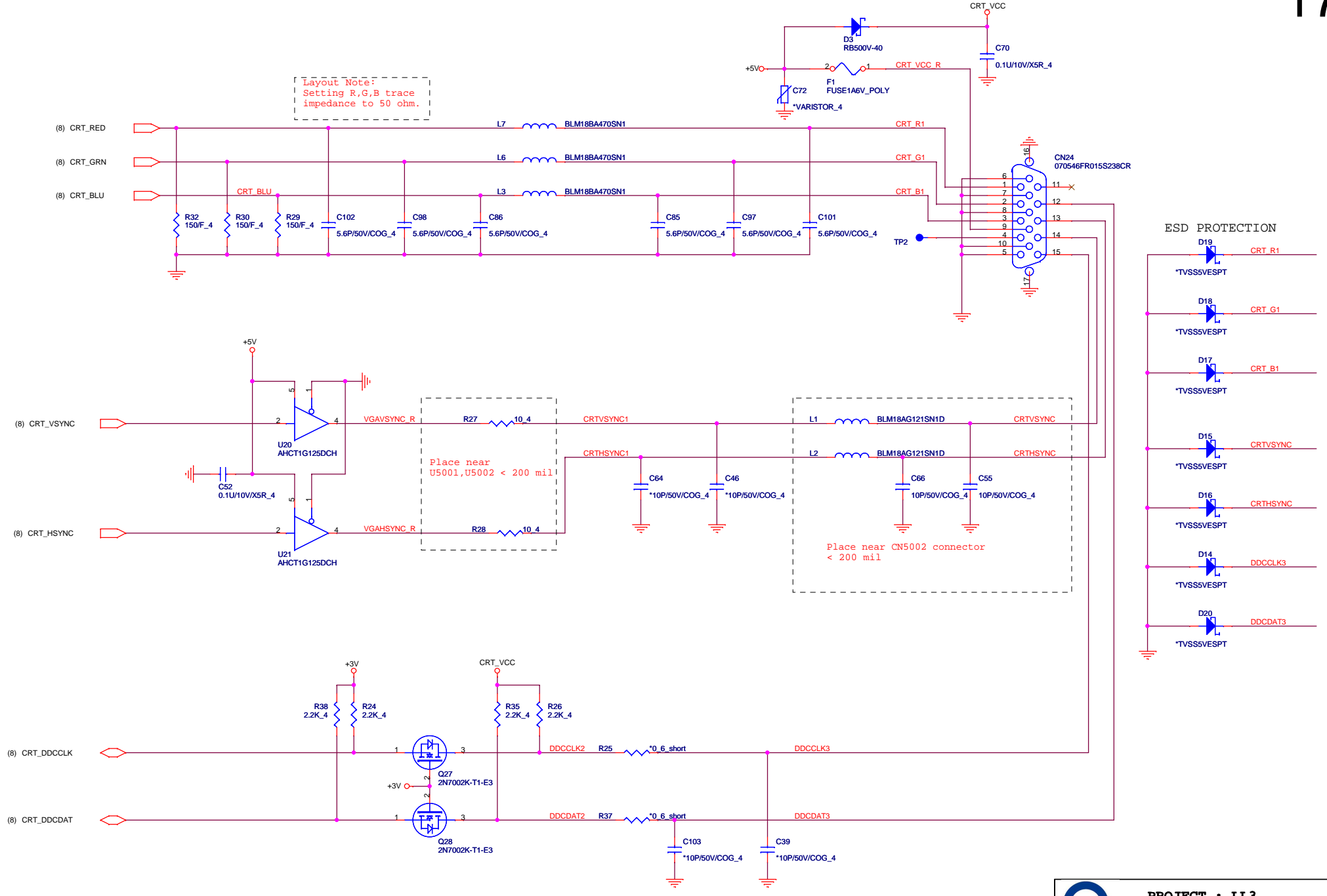

PROJECT : LL3
Quanta Computer Inc.

Size Custom	Document Number CRT CONN	Rev 1A
Date: Wednesday, October 21, 2009 Sheet 17 of 42		

DisplayPort

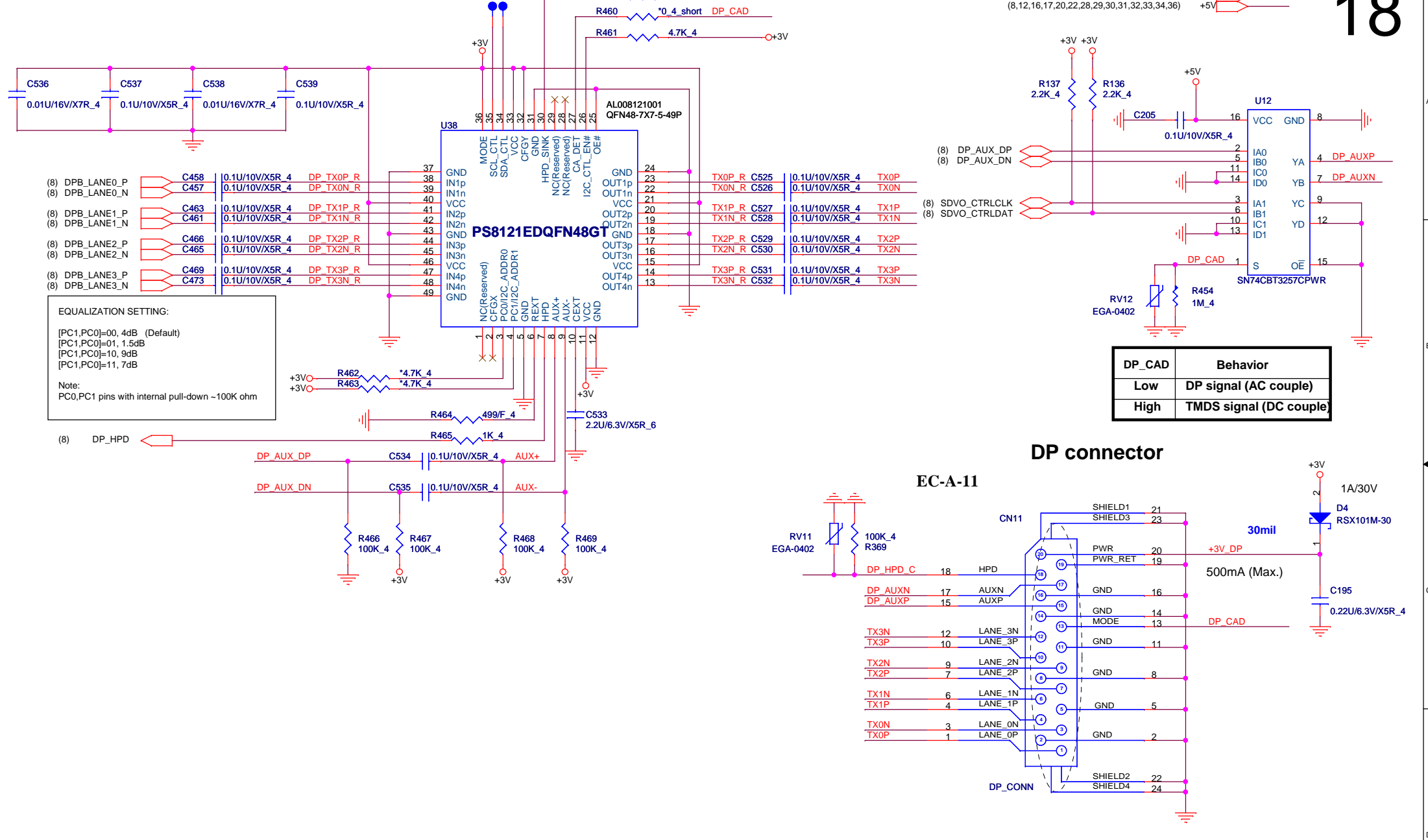

EQUALIZATION SETTING:
 [PC1,PC0]=00, 4dB (Default)
 [PC1,PC0]=01, 1.5dB
 [PC1,PC0]=10, 9dB
 [PC1,PC0]=11, 7dB
 Note:
 PC0,PC1 pins with internal pull-down ~100K ohm

DP_CAD	Behavior
Low	DP signal (AC couple)
High	TMDS signal (DC couple)

DP connector

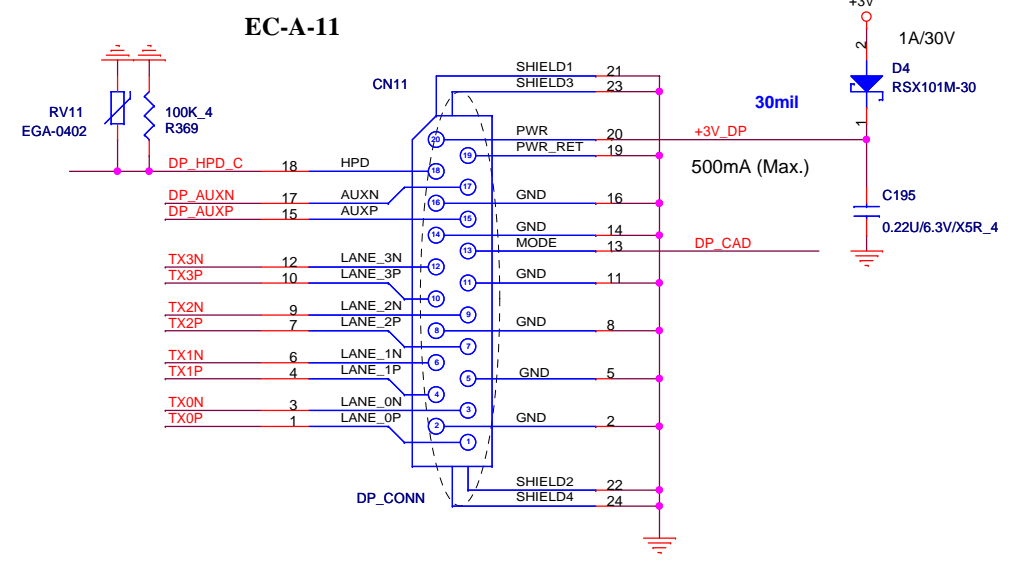



PROJECT : LL3
Quanta Computer Inc.

Size Custom	Document Number DISPLAYPORT CONN	Rev 1A
Date:	Wednesday, October 21, 2009	Sheet 18 of 42

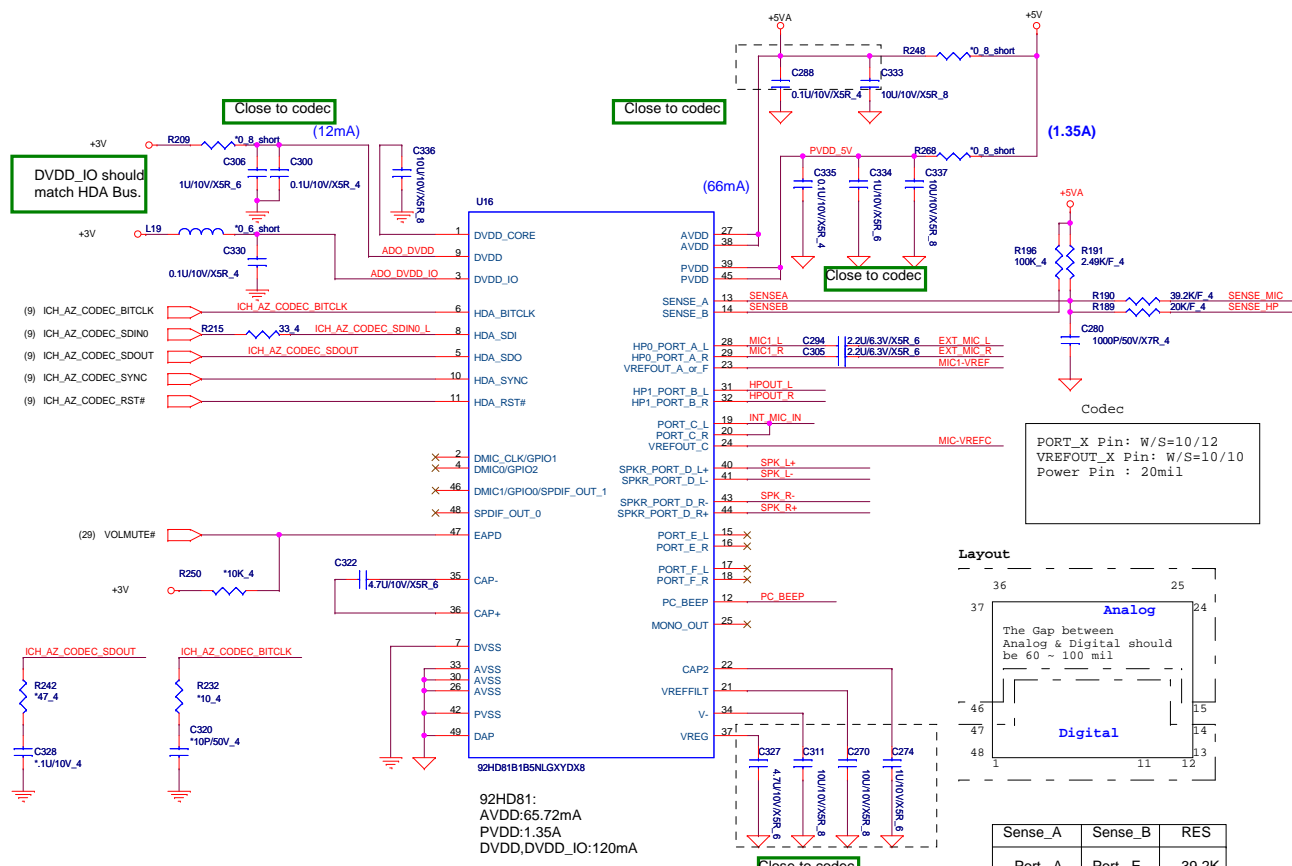

Codec
 PORT_X Pin: W/S=10/12
 VREFOUT_X Pin: W/S=10/10
 Power Pin : 20mil

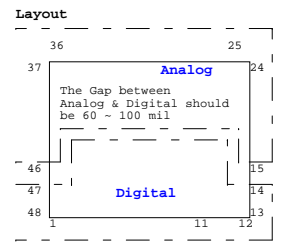

Sense_A	Sense_B	RES
Port_A	Port_E	39.2K
Port_B	Port_F	20K

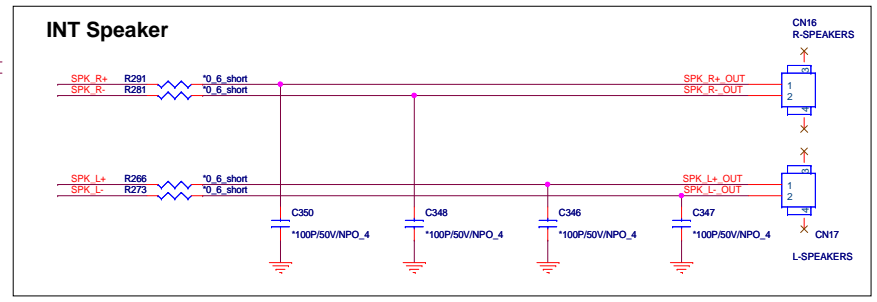

Headphone out

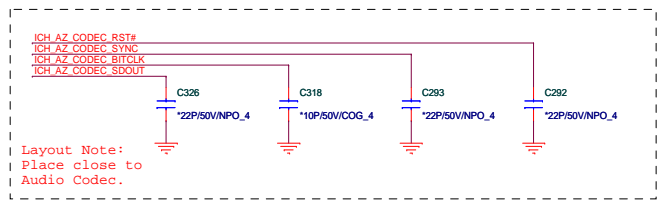
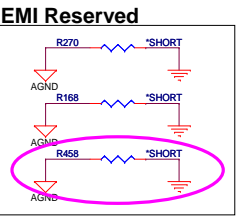
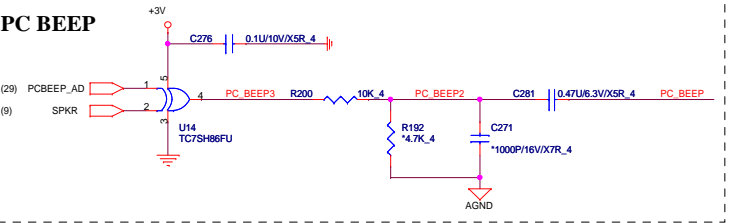
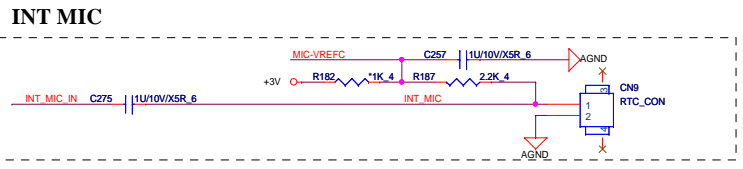
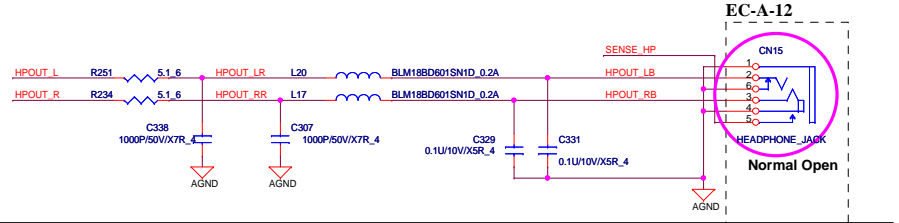

Layout Note:
 Place close to
 Audio Codec.

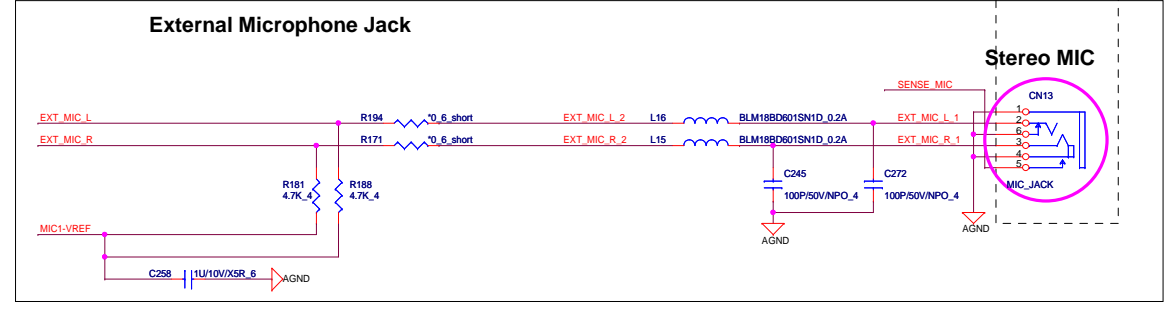

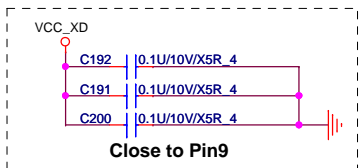
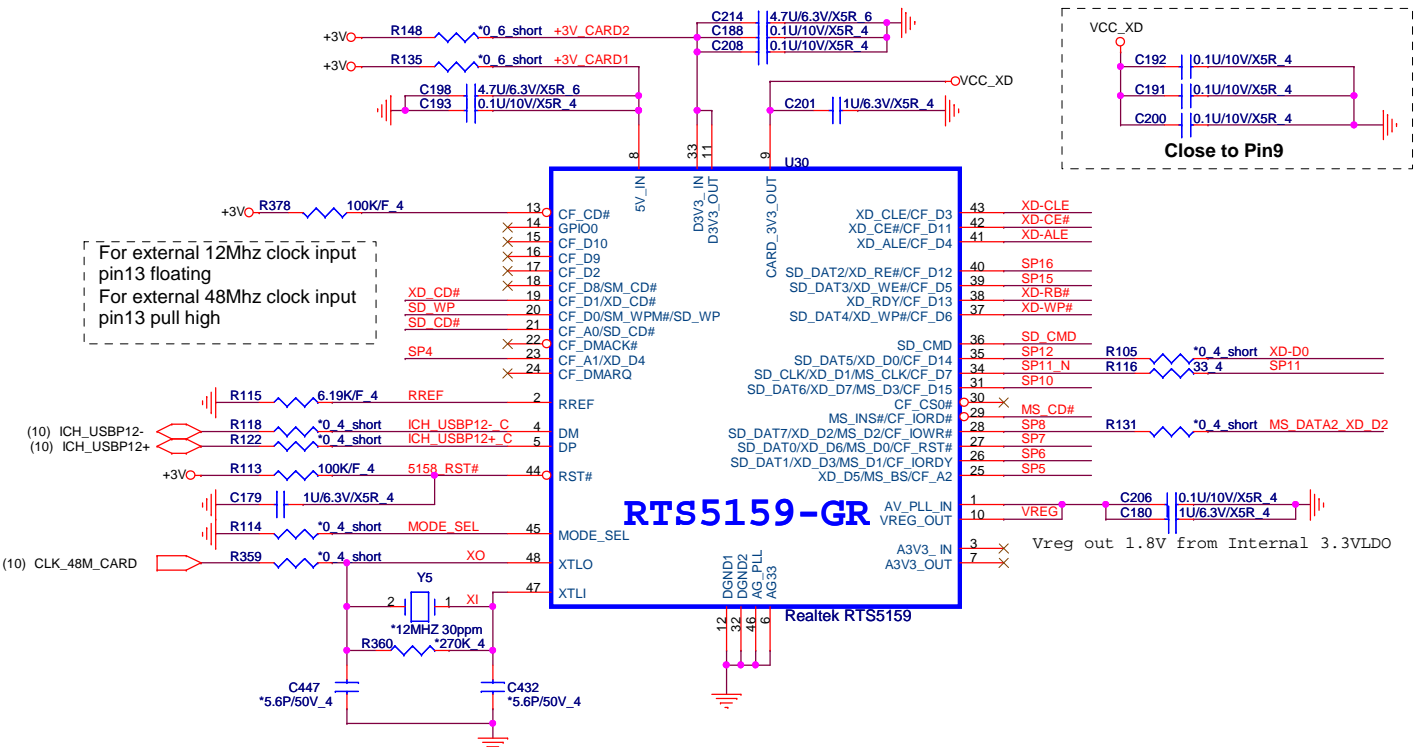

Note:

SP0	SD/MMC	MS	XD
SP1			XD_CD#
SP2	SD_WP		
SP3	SD_CD#		
SP4	SD_DAT1		XD_D4
SP5		MS_BS	XD_D5
SP6		MS_D1	XD_D3
SP7	SD_DAT0	MS_D0	XD_D6
SP8	SD_DAT7	MS_D2	XD_D2
SP9		MS_IN#	
SP10	SD_DAT6	MS_D3	XD_D7
SP11	SD_CLK	MS_SCLK	XD_D1
SP12	SD_DAT5		XD_D0
SP13	SD_DAT4		XD_WP#
SP14			XD_RB#
SP15	SD_DAT3		XD_WE#
SP16	SD_DAT2		XD_RE#
SP17			XD_ALE
SP18			XD_CE#
SP19			XD_CLE

For RTS5159

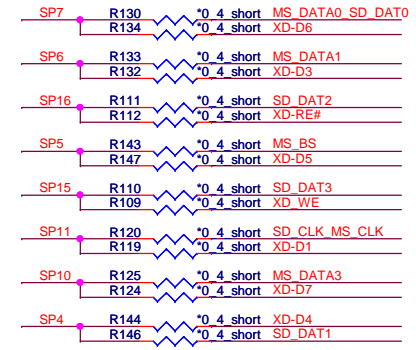

5 IN1 CARD READER XD, MMC/SD, MS/MSP

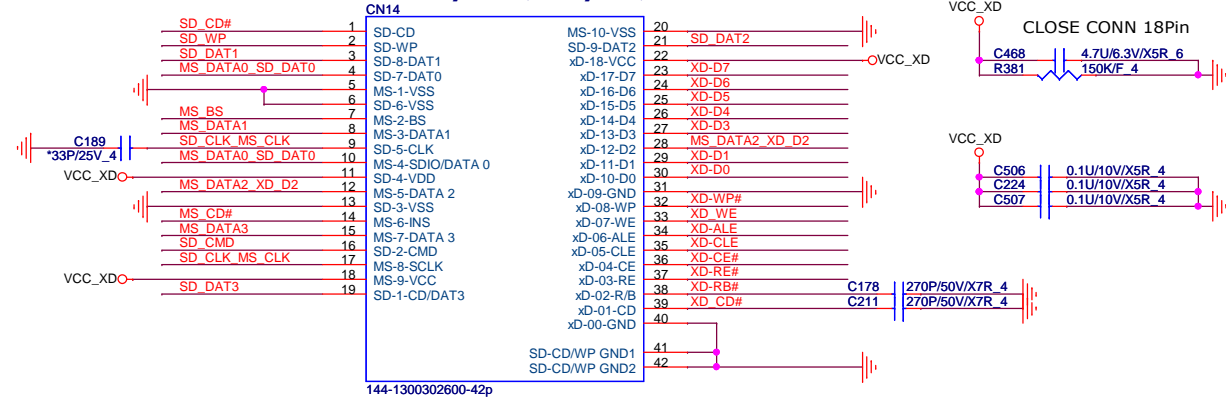

PROJECT : LL3
Quanta Computer Inc.

Size B	Document Number	Rev 1A
	Card Reader (RTS5159)	
Date:	Wednesday, October 21, 2009	Sheet 21 of 42

SATA-HDD CONNECTOR

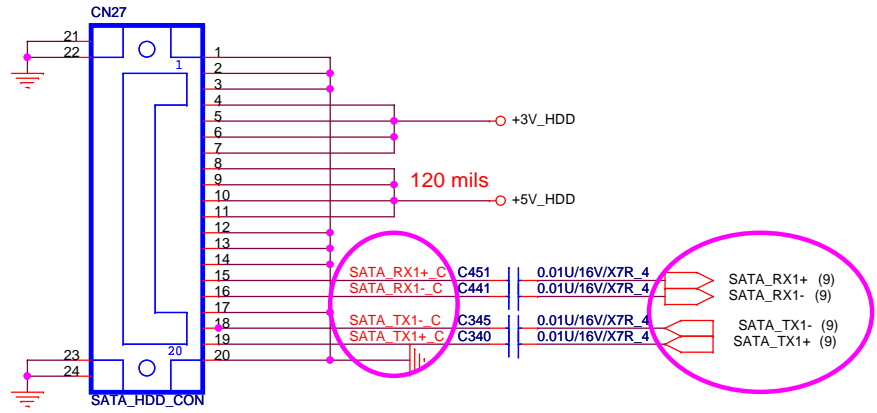

(3,4,6,8,9,10,11,12,14,15,16,17,18,20,21,23,24,25,26,27,28,29,31,33,34,36,37,38,39,40)
 (8,12,16,17,18,20,28,29,30,31,32,33,34,36)

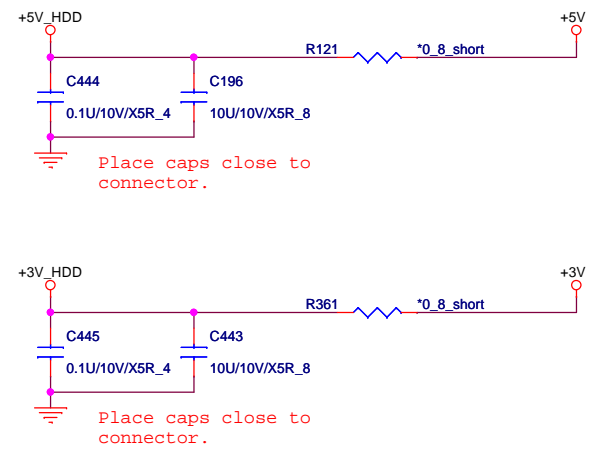
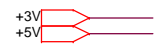

SATA CD-ROM

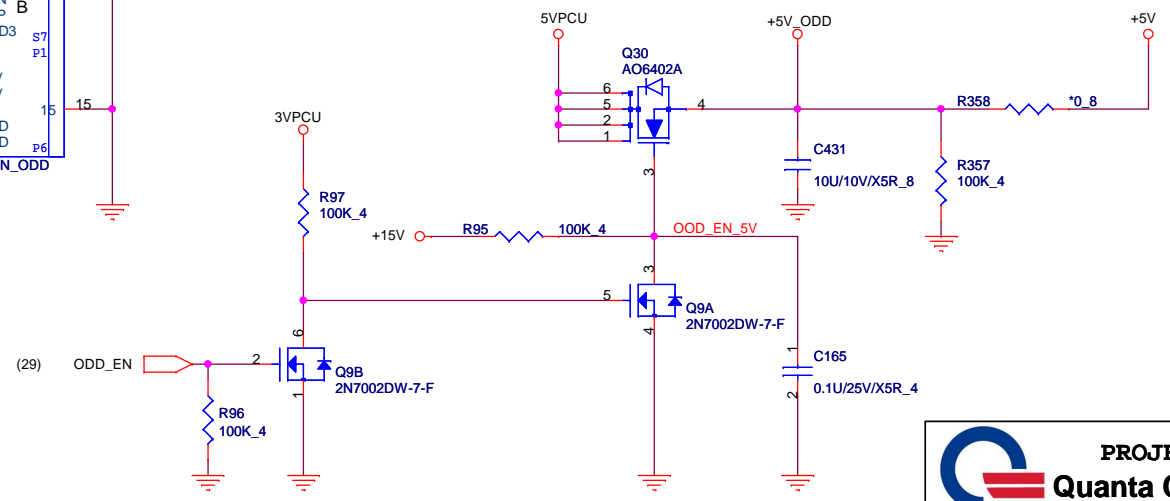
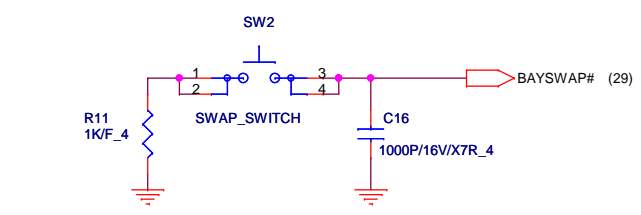
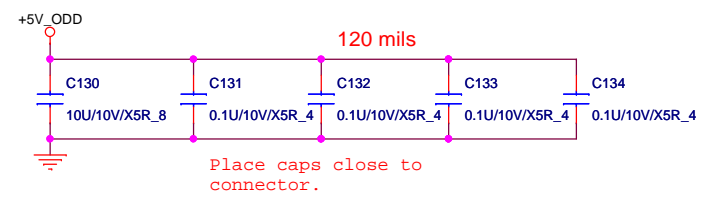
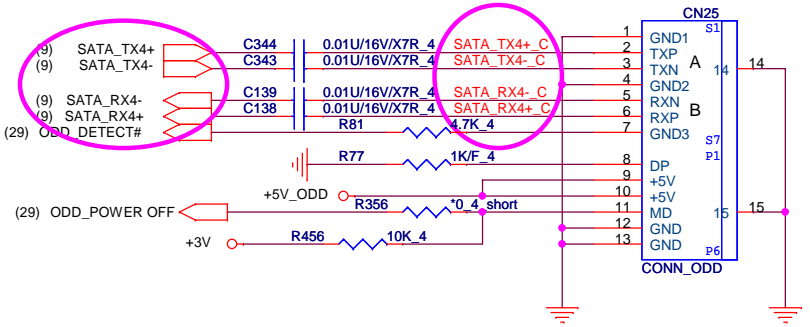

PROJECT : LL3
Quanta Computer Inc.

Size Custom	Document Number	Rev 1A
HDD/ODD		
Date: Wednesday, October 21, 2009	Sheet 22 of 42	

USB 3

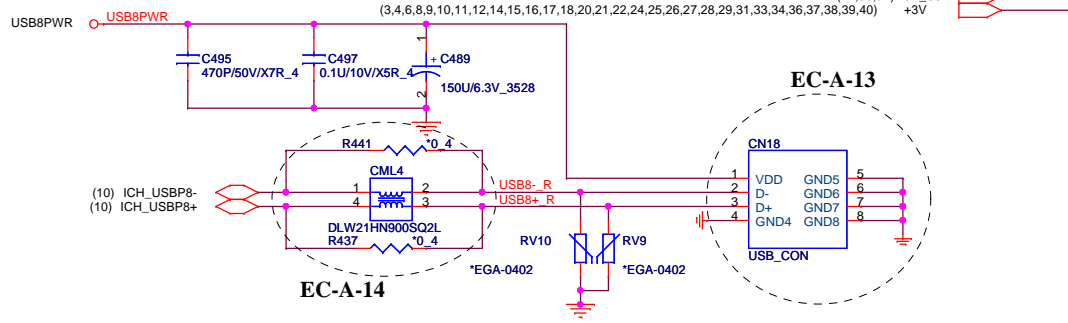
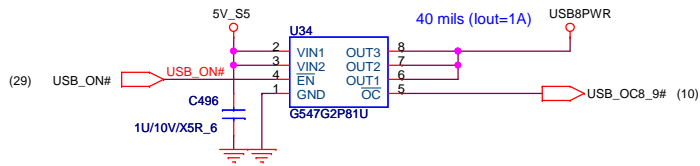

USB 2

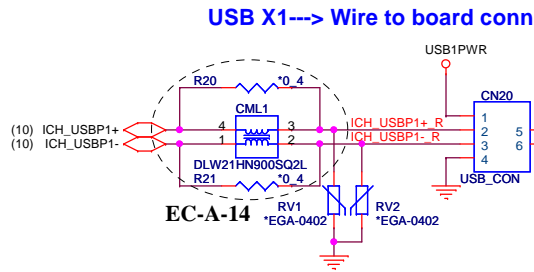
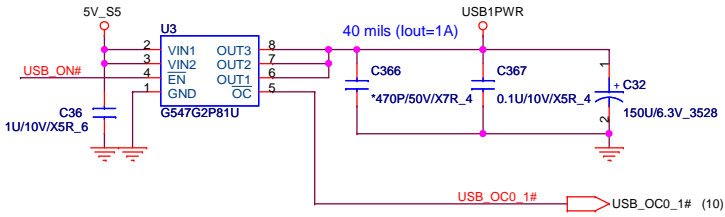

USB 4

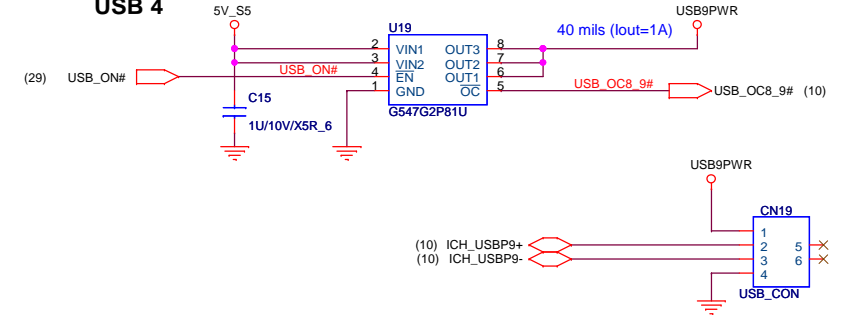

USB 1

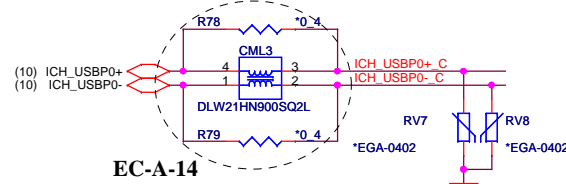
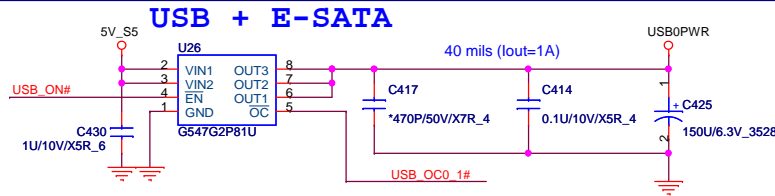

E-SATA RE-DRIVER

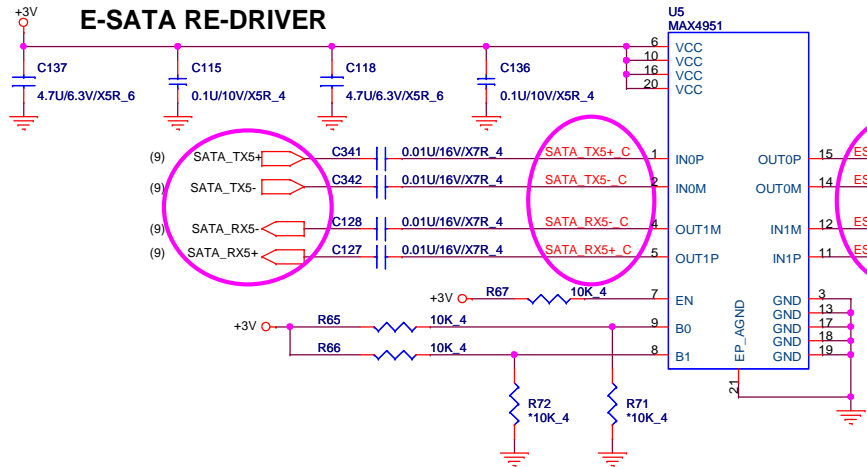

EN	B0	B1	FUNCTION
0	X	X	Standby
1	0	0	Standard SATA Output
1	1	0	Ch 0 Boost Output
1	0	1	Ch 1 Boost Output
1	1	1	Ch 0,1 Boost Output

PROJECT : LL3
Quanta Computer Inc.

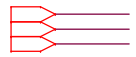

MiniCard WLAN/WiMAX connector

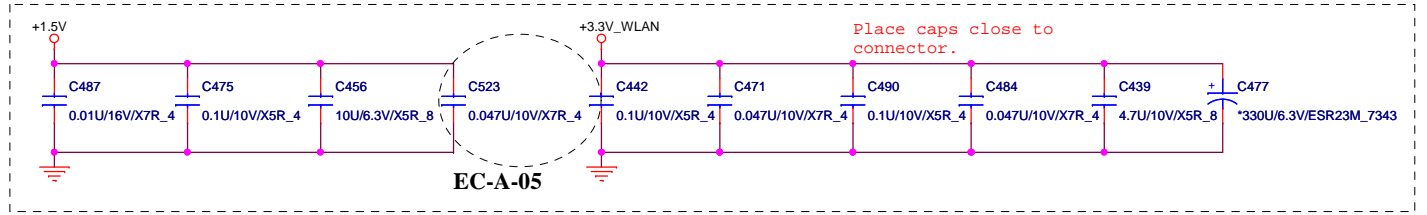
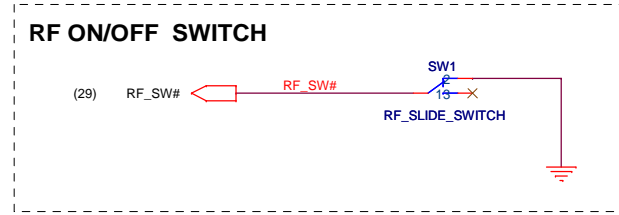
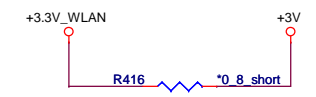
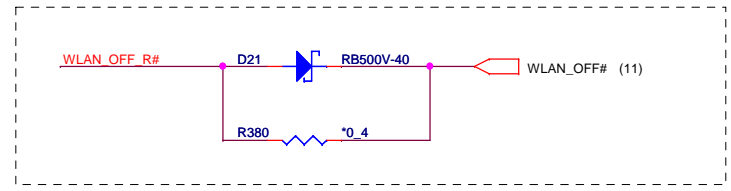
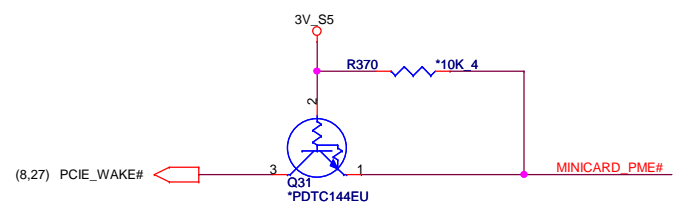
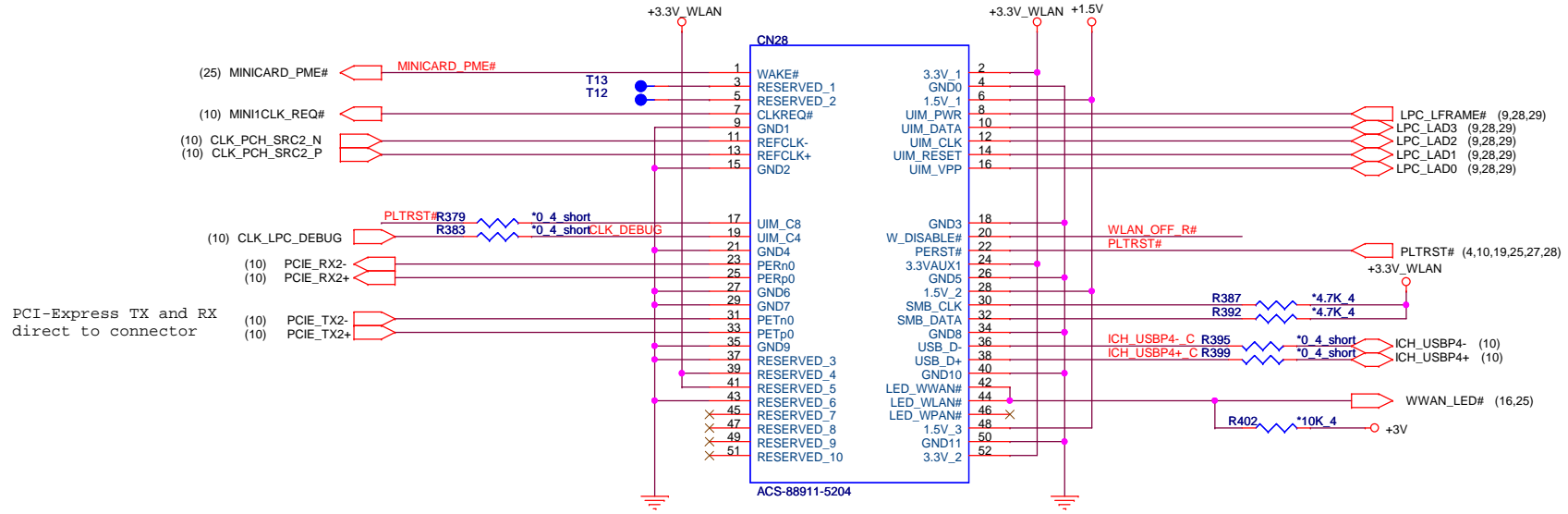



MiniCard WWAN connector

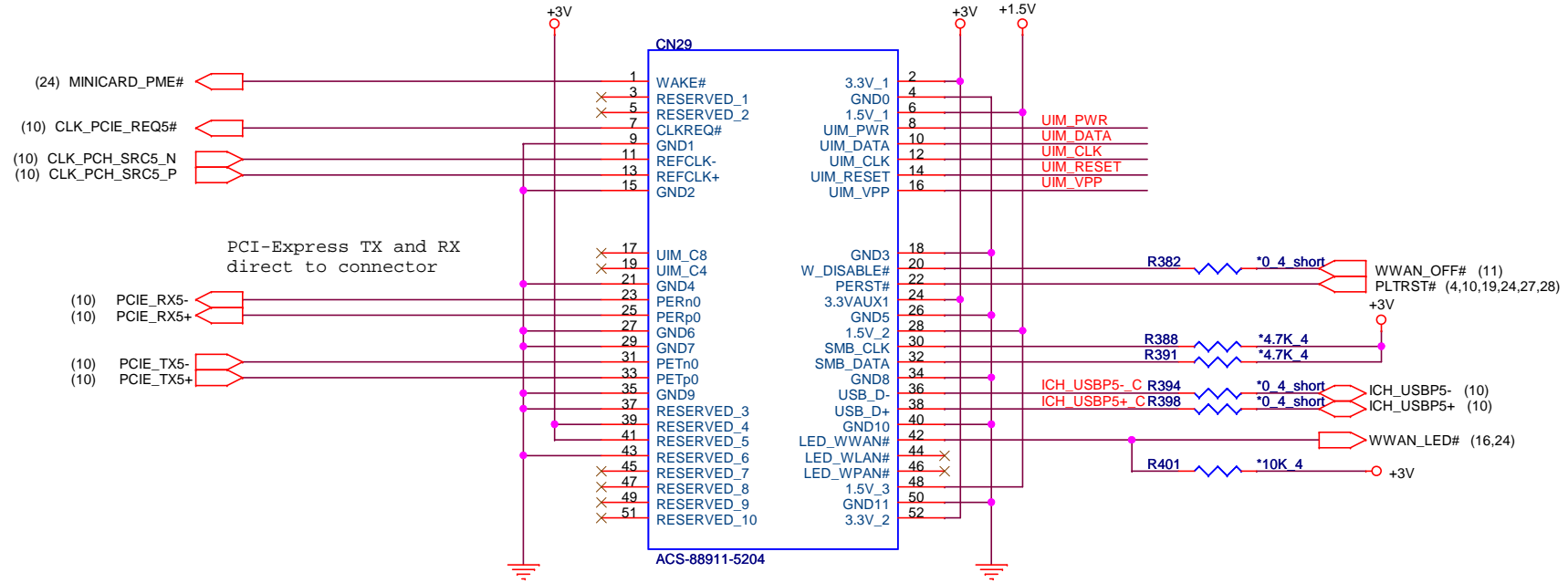

SIM Card CONN

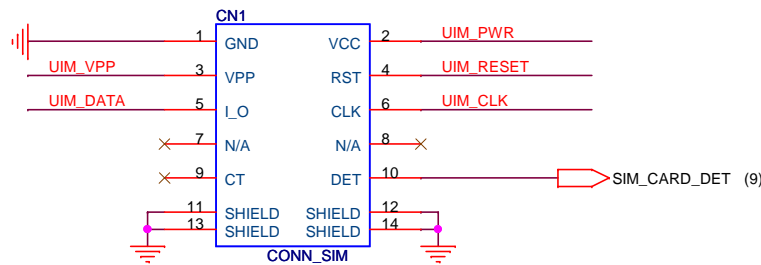

Layout Note:
 UIM_RESET, UIM_CLK, UIM_DATA routing as short as possible

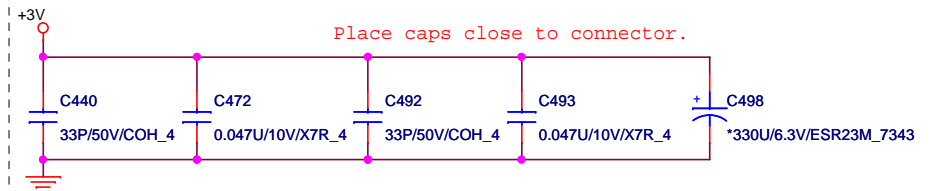
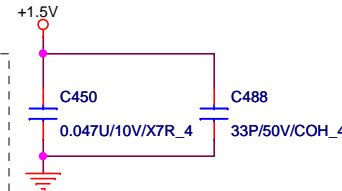
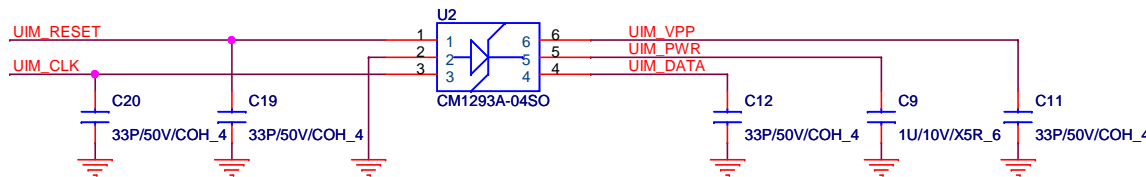

		PROJECT : LL3	
		Quanta Computer Inc.	
Size Custom	Document Number	MINI-Card (WWAN)	
Date:	Wednesday, October 21, 2009	Sheet	25 of 42
			Rev 1A

Mini PCI-E Card 3 SSD

(3,4,6,8,9,10,11,12,14,15,16,17,18,20,21,22,23,24,25,27,28,29,31,33,34,36,37,38,39,40) +1.5V
 (3,24,25,27,37) +3V

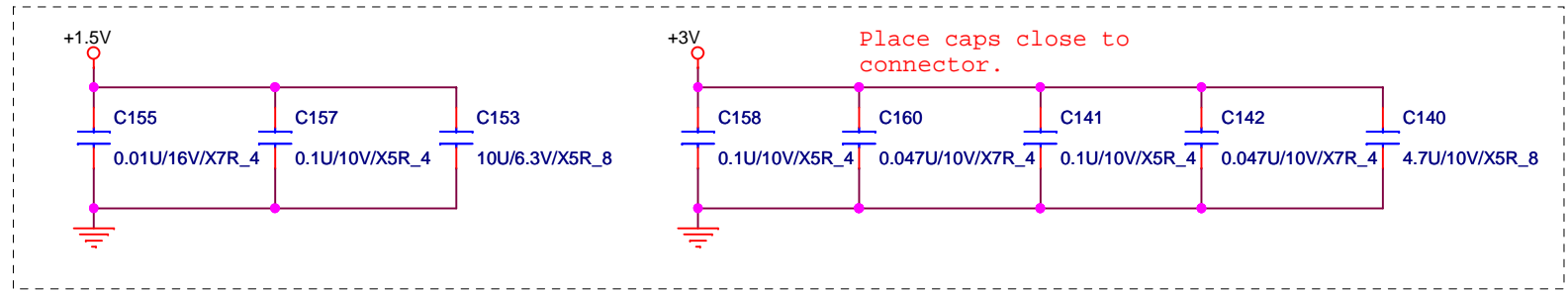
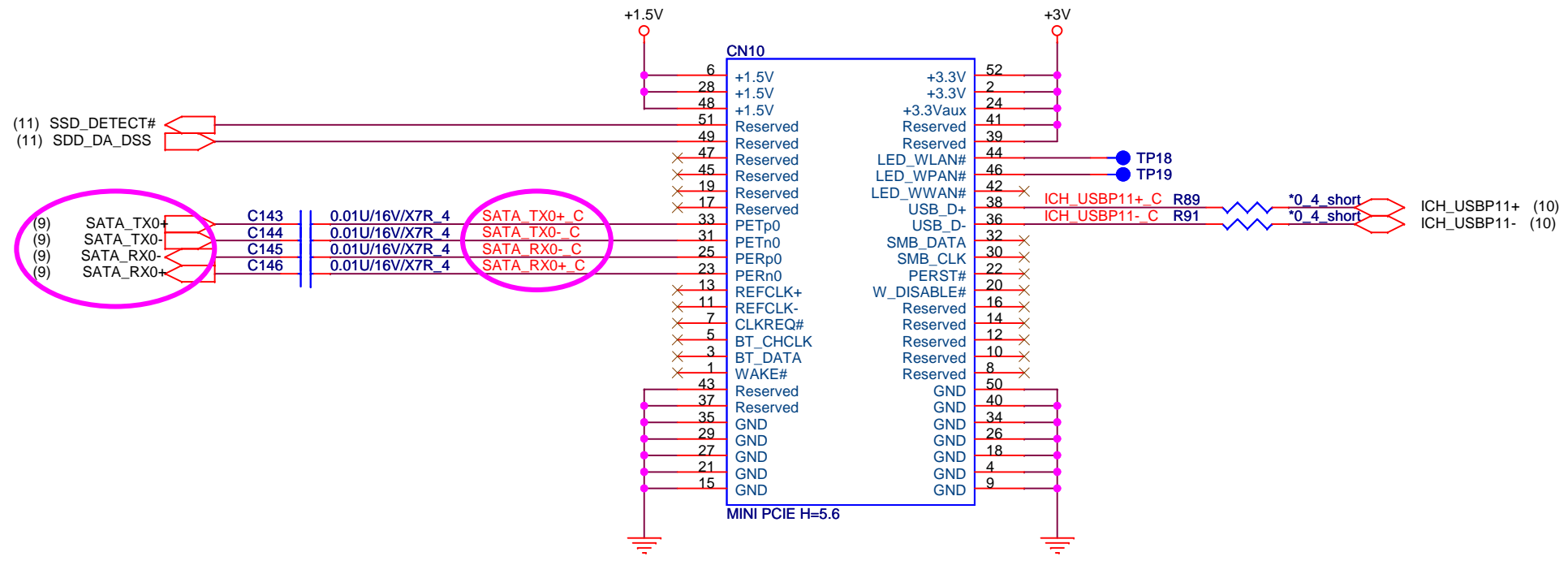

PROJECT : LL3
Quanta Computer Inc.

Size Custom	Document Number	Rev 1A
Date: Wednesday, October 21, 2009		Sheet 26 of 42
MINI Card (SSD)		

Express Card

(3,4,6,8,9,10,11,12,14,15,16,17,18,20,21,22,23,24,25,26,28,29,31,33,34,36,37,38,39,40) +3V
 (3,24,25,26,37) +1.5V
 (28,29,34,41) 3VSUS

27

+1.5V_CARD Max. 650mA, Average 500mA.
 +3.3V_CARD Max. 1300mA, Average 1000mA.

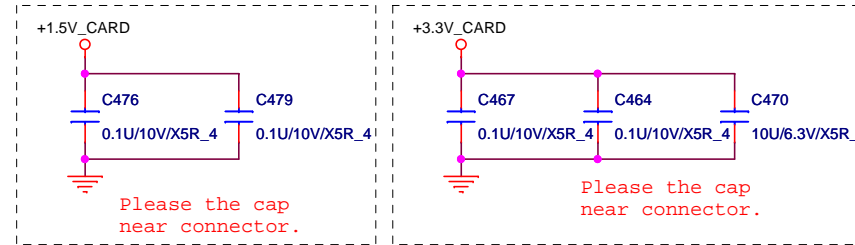
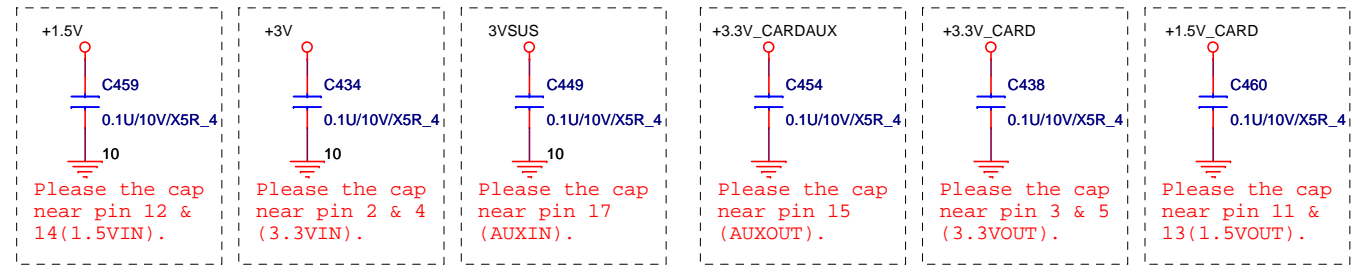
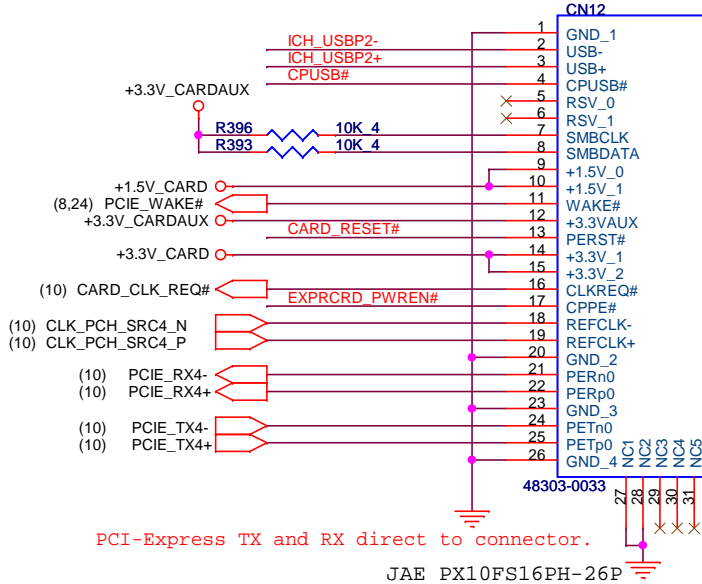
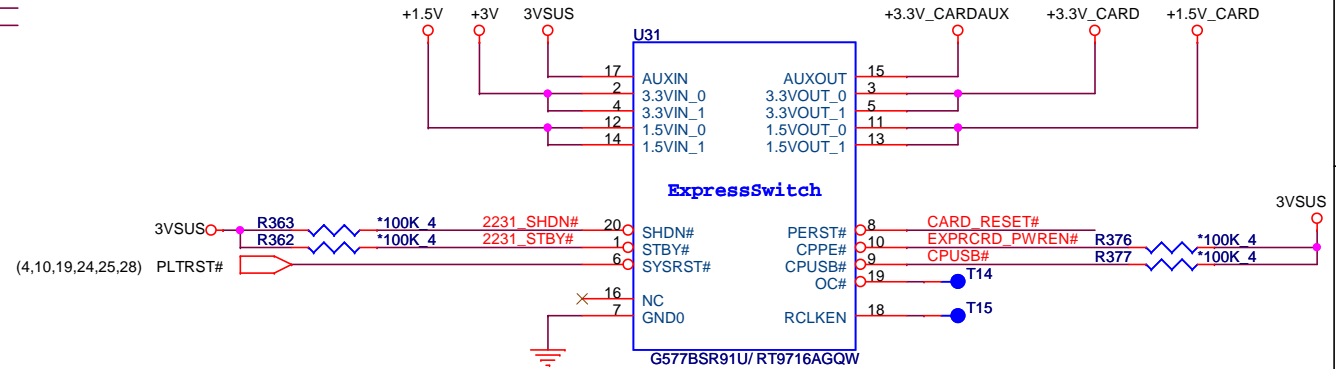
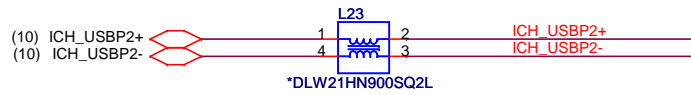

PROJECT : LL3
Quanta Computer Inc.

Size Custom	Document Number	Rev 1A
Express Card		
Date:	Wednesday, October 21, 2009	Sheet 27 of 42

BLUETOOTH

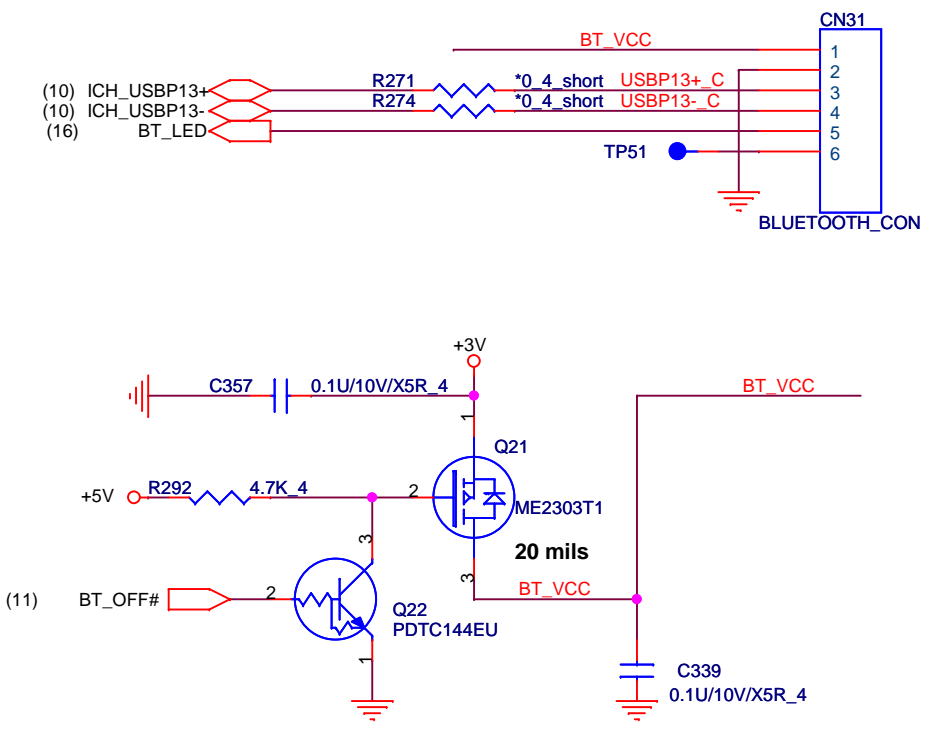

FINGER PRINTER

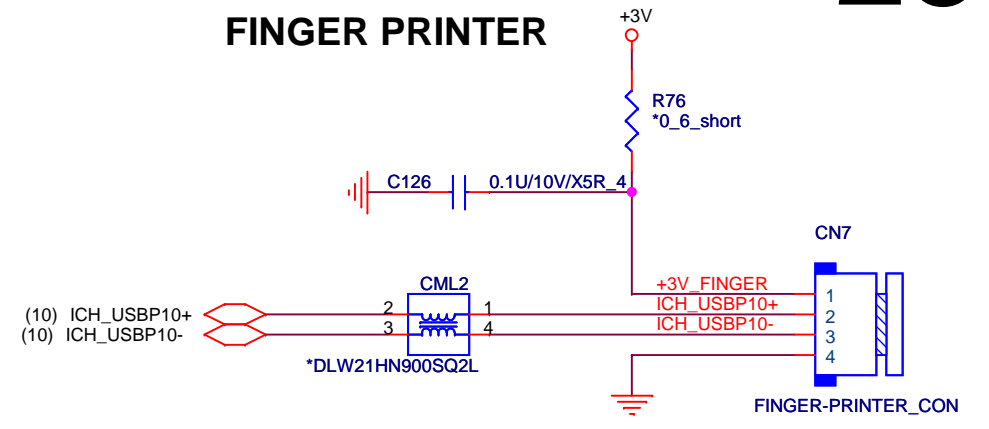

TPM

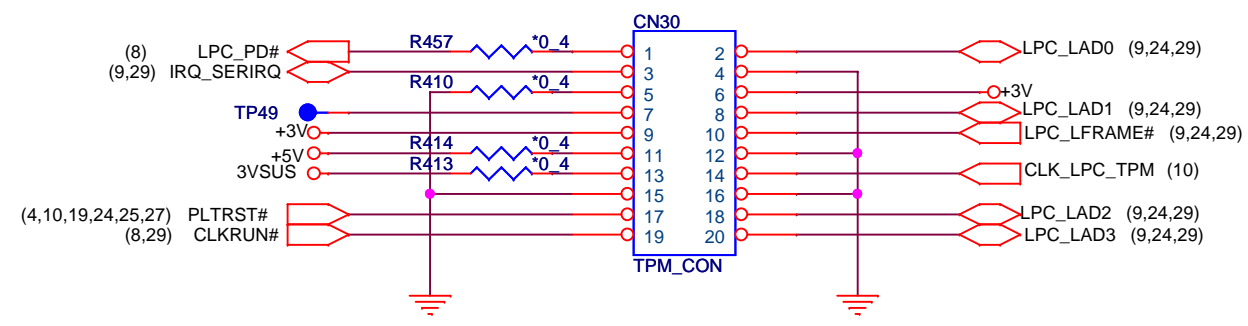

 PROJECT : LL3 Quanta Computer Inc.		Size	Document Number	Rev
		Custom	BT/FP/TPM	1A
Date:	Wednesday, October 21, 2009	Sheet	28	of 42

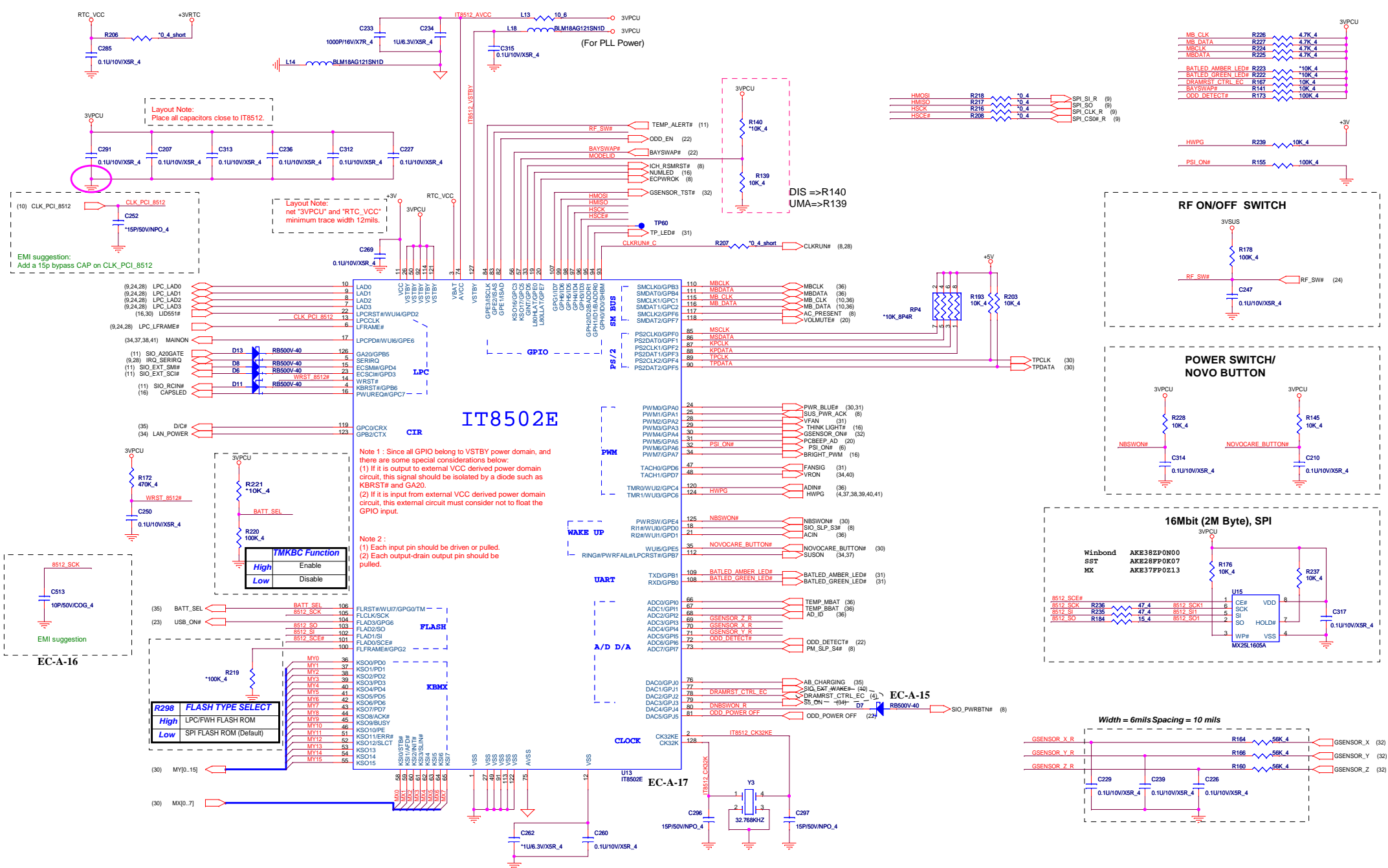

Layout Note:
Place all capacitors close to IT8512.

Layout Note:
net "3VPCU" and "RTC_VCC"
minimum trace width 12mils.

EMI suggestion:
Add a 15p bypass CAP on CLK_PCI_8512

Note 1 : Since all GPIO belong to VSTBY power domain, and there are some special considerations below:
(1) If it is output to external VCC derived power domain circuit, this signal should be isolated by a diode such as KBRST# and GA20.
(2) If it is input from external VCC derived power domain circuit, this external circuit must consider not to float the GPIO input.

Note 2 :
(1) Each input pin should be driven or pulled.
(2) Each output-drain output pin should be pulled.

TMKBC Function

High	Enable
Low	Disable

R298 FLASH TYPE SELECT

High	LPC/FWH FLASH ROM
Low	SPI FLASH ROM (Default)

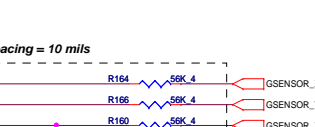
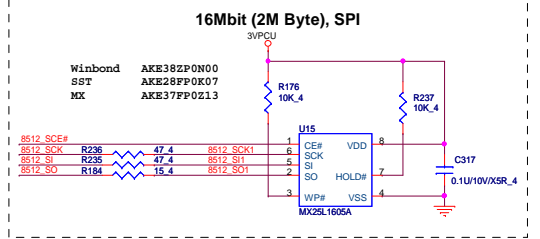
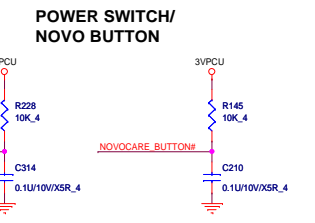
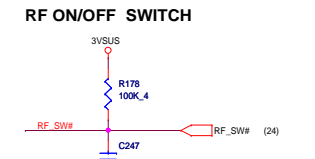
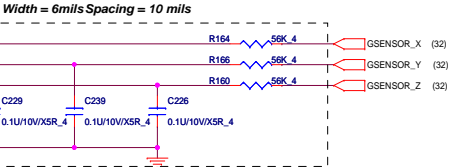

KEYBOARD

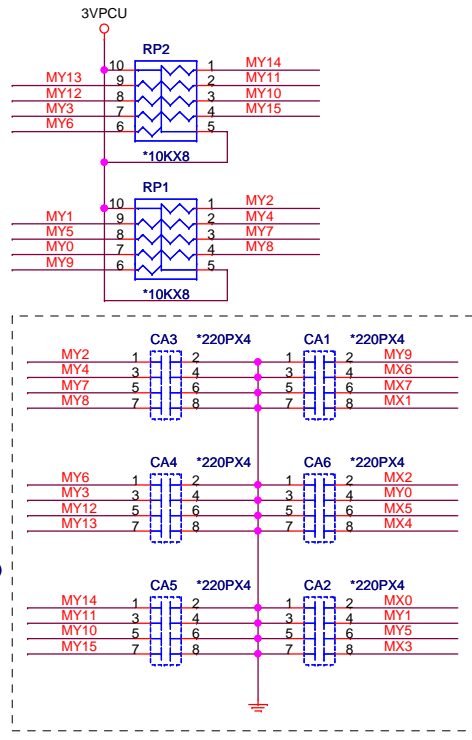
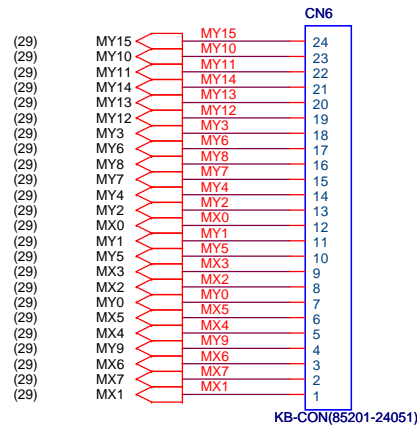

FUNCTION BUTTON BOARD

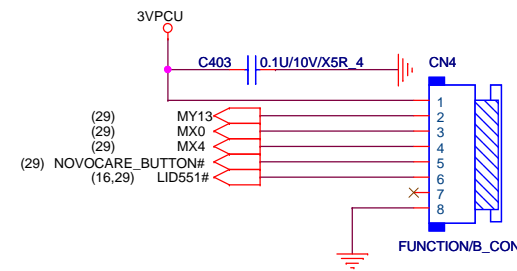

TOUCH PAD

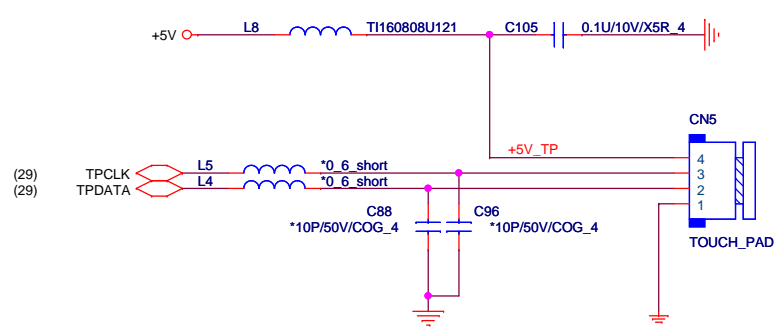

POWER BUTTON BOARD

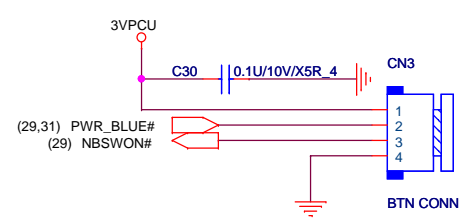

LED

(3,4,6,8,9,10,11,12,14,15,16,17,18,20,21,22,23,24,25,26,27,28,29,33,34,36,37,38,39,40)
 (8,12,16,17,18,20,22,28,29,30,32,33,34,36)
 (9,16,19,22,29,30,34,36,39,41)

+3V
 +5V
 3VPCU

31

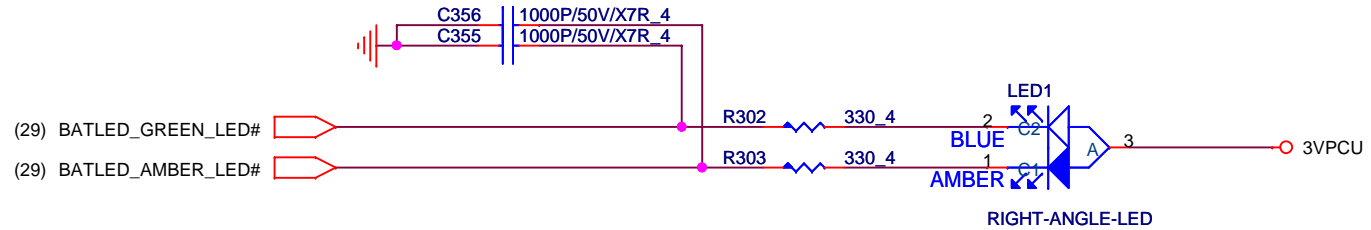
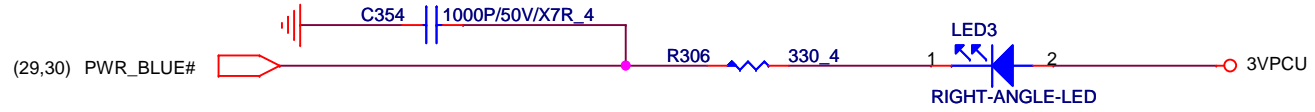

EC-A-18

FAN CONTROL

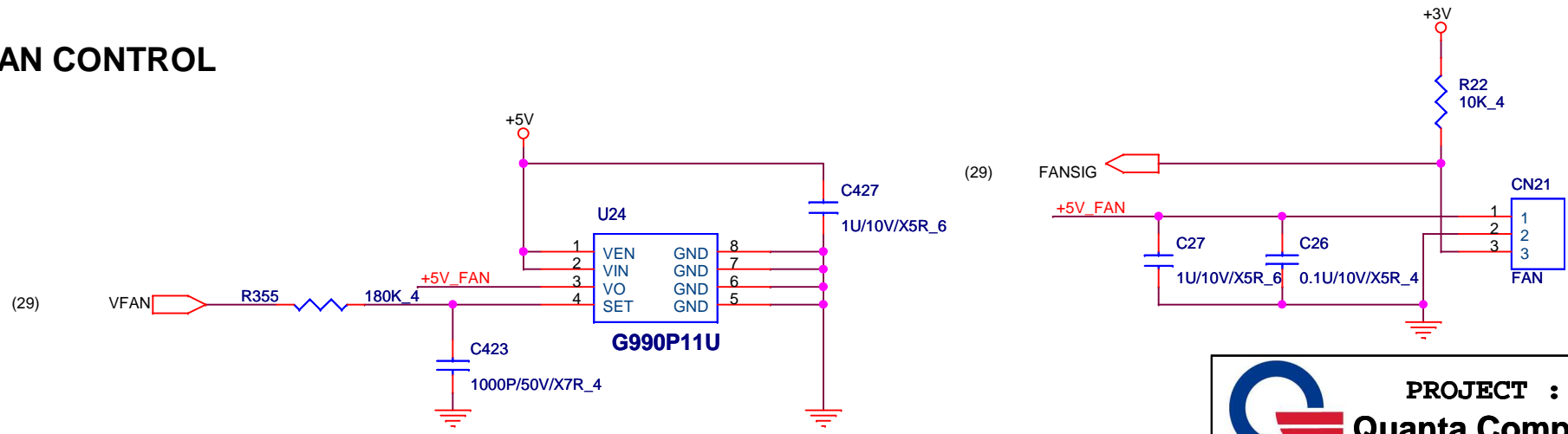

PROJECT : LL3
Quanta Computer Inc.

Size Custom	Document Number LED/FAN	Rev 1A
Date: Wednesday, October 21, 2009		Sheet 31 of 42

G-SENSOR (2-Axial)

(8,12,16,17,18,20,22,28,29,30,31,33,34,36) +5V

32

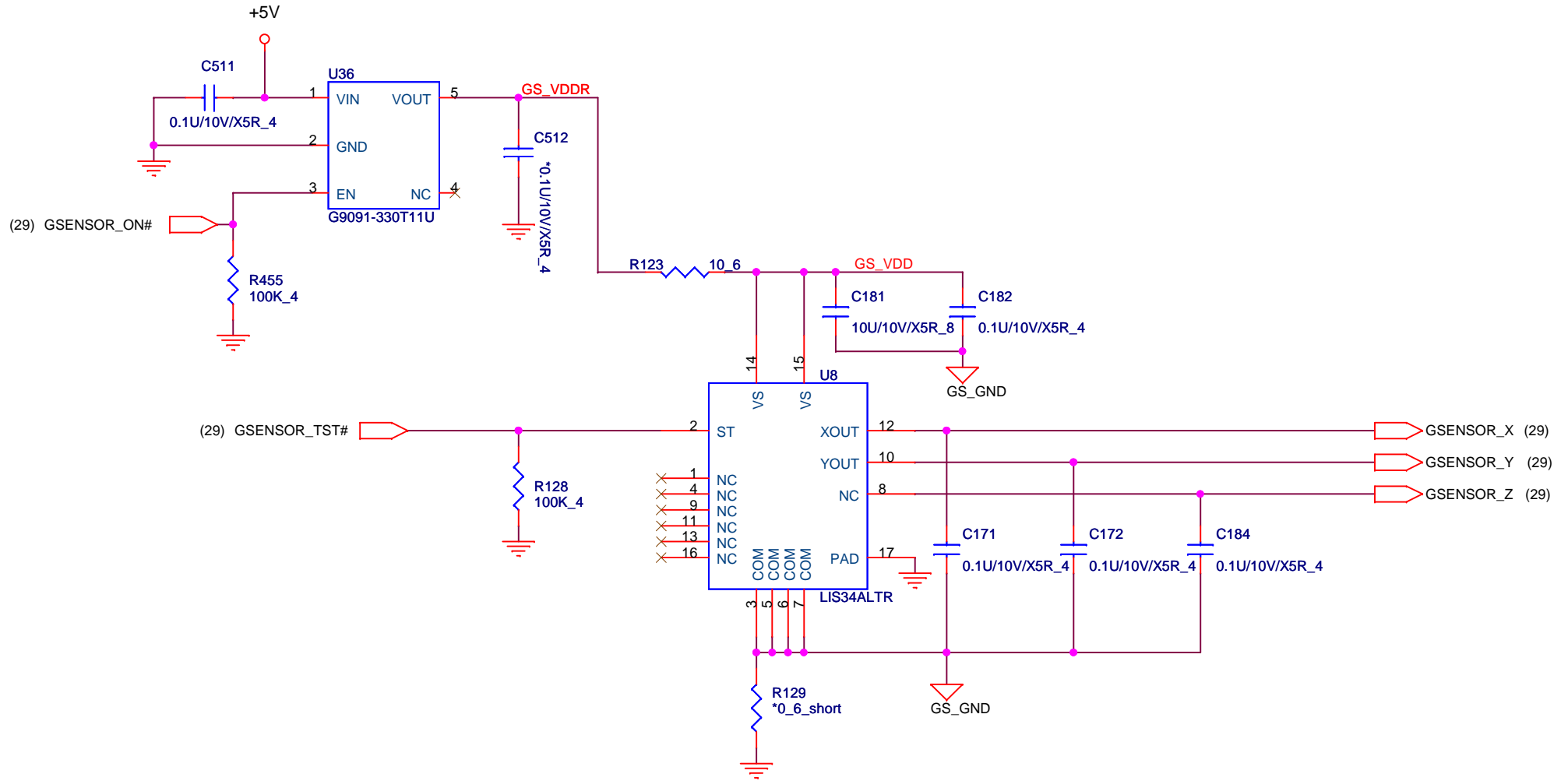

		PROJECT : LL3	
		Quanta Computer Inc.	
Size Custom	Document Number	G-SENSOR	
Date:	Wednesday, October 21, 2009	Sheet	32 of 42
			Rev 1A

Hole for CPU support

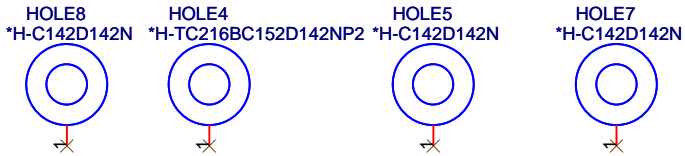

MINI CARD nut (SSD)

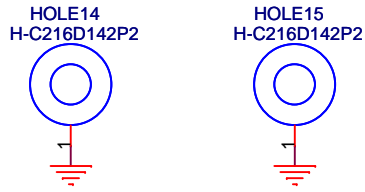

Hole for PCH Thermal

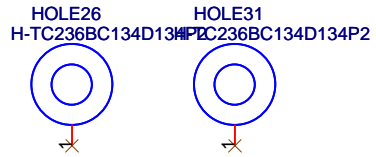

Drink Hole

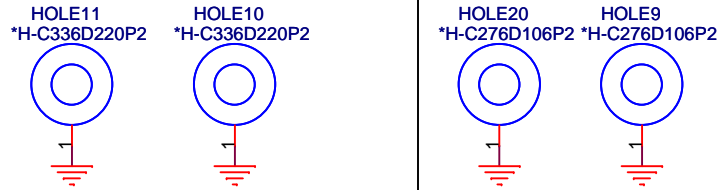

MINI CARD nut (WLAN)

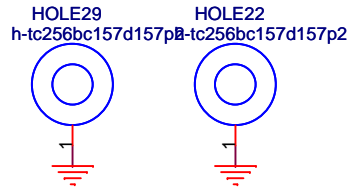

MINI CARD nut (WWAN)

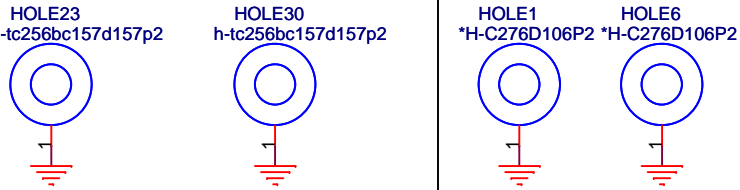

Hole for TPM Module

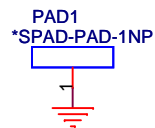
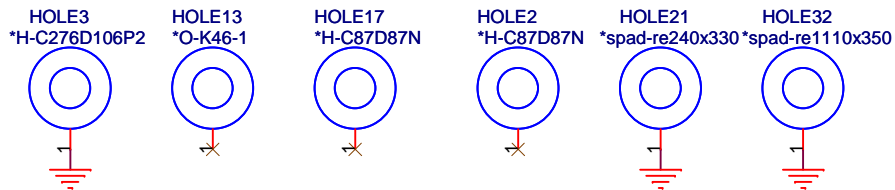
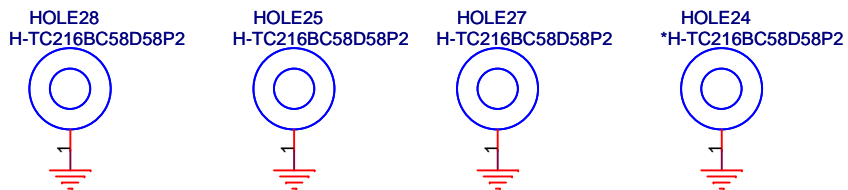

For EMI

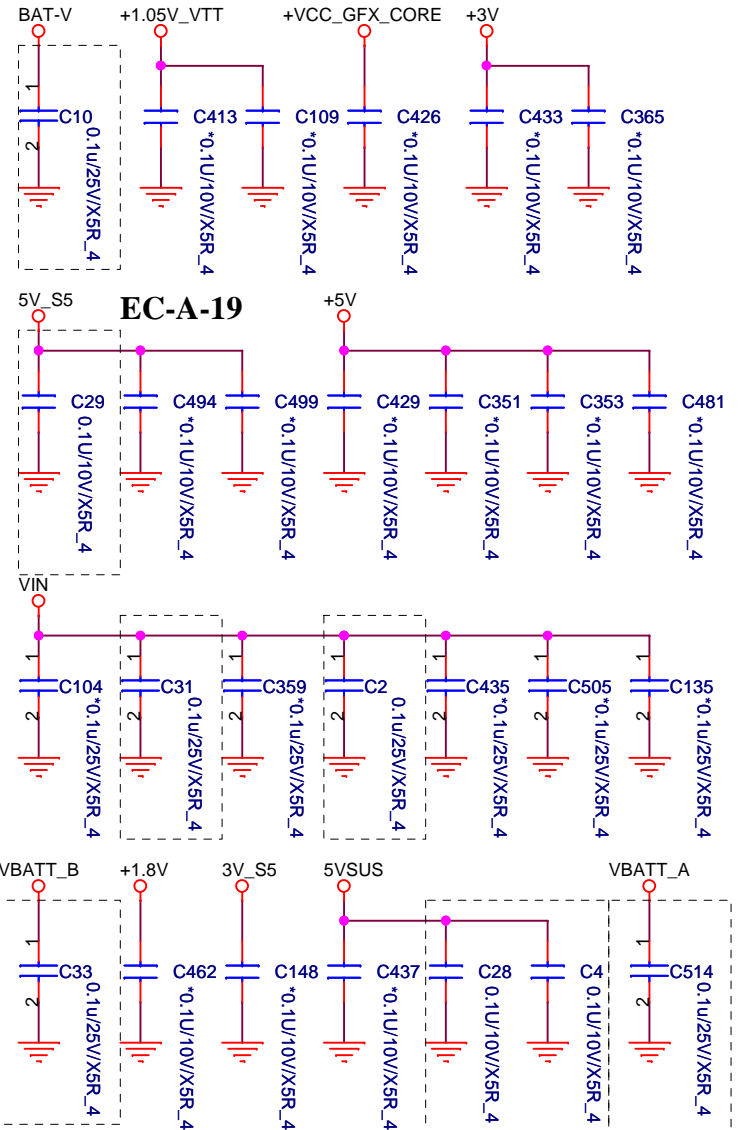

PROJECT : LL3

Quanta Computer Inc.

Size Custom	Document Number HOLD & SKEW	Rev 1A
Date: Wednesday, October 21, 2009	Sheet 33	of 42

DISCHARGE

+3.3V, +5V

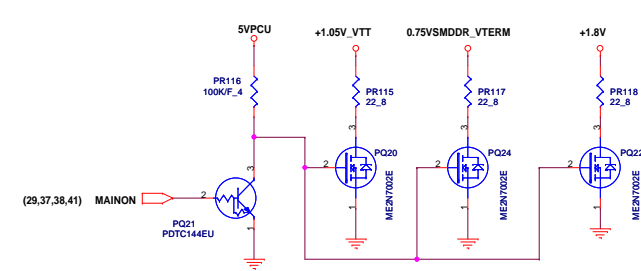
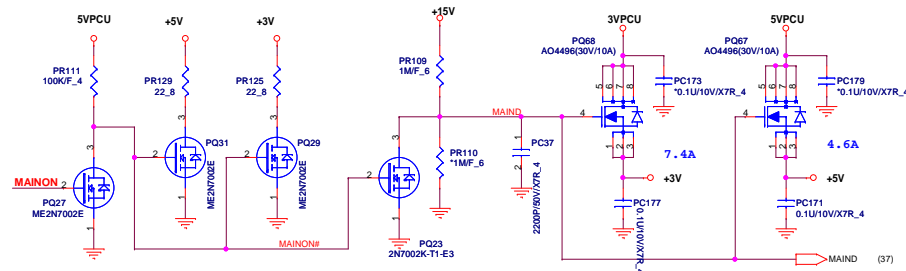

3V_S5, 5V_S5

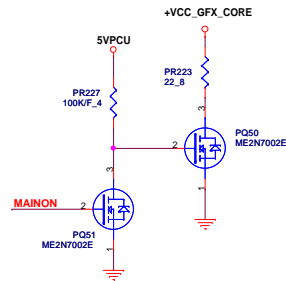
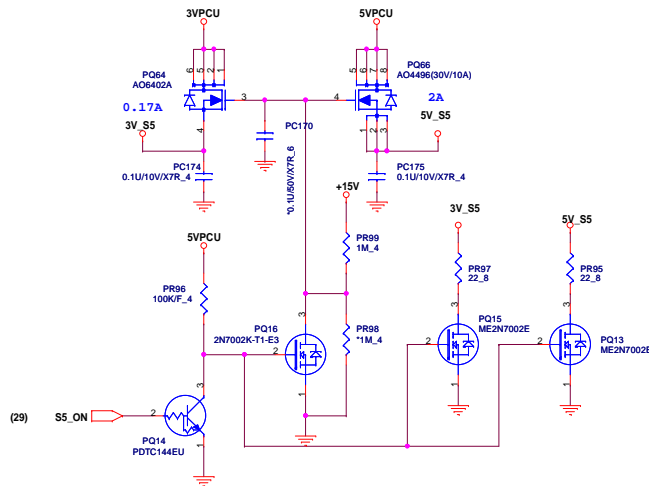

LANVCC

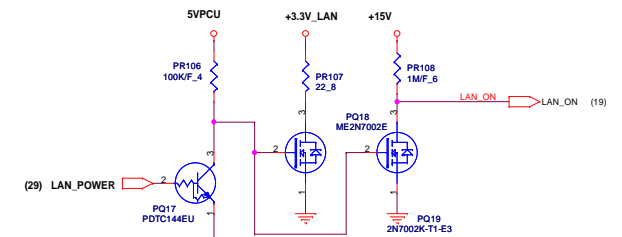

3VSUS, 5VSUS

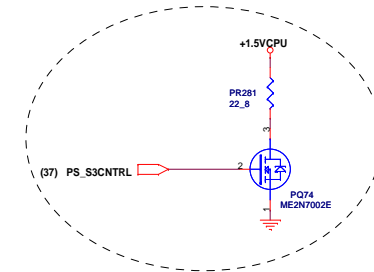
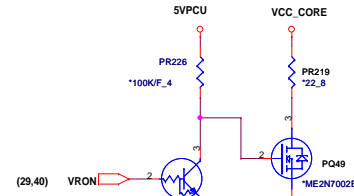
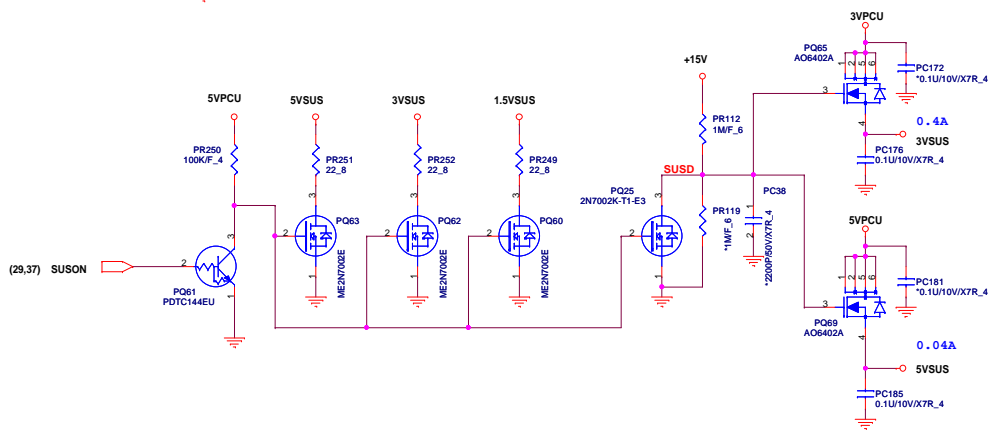

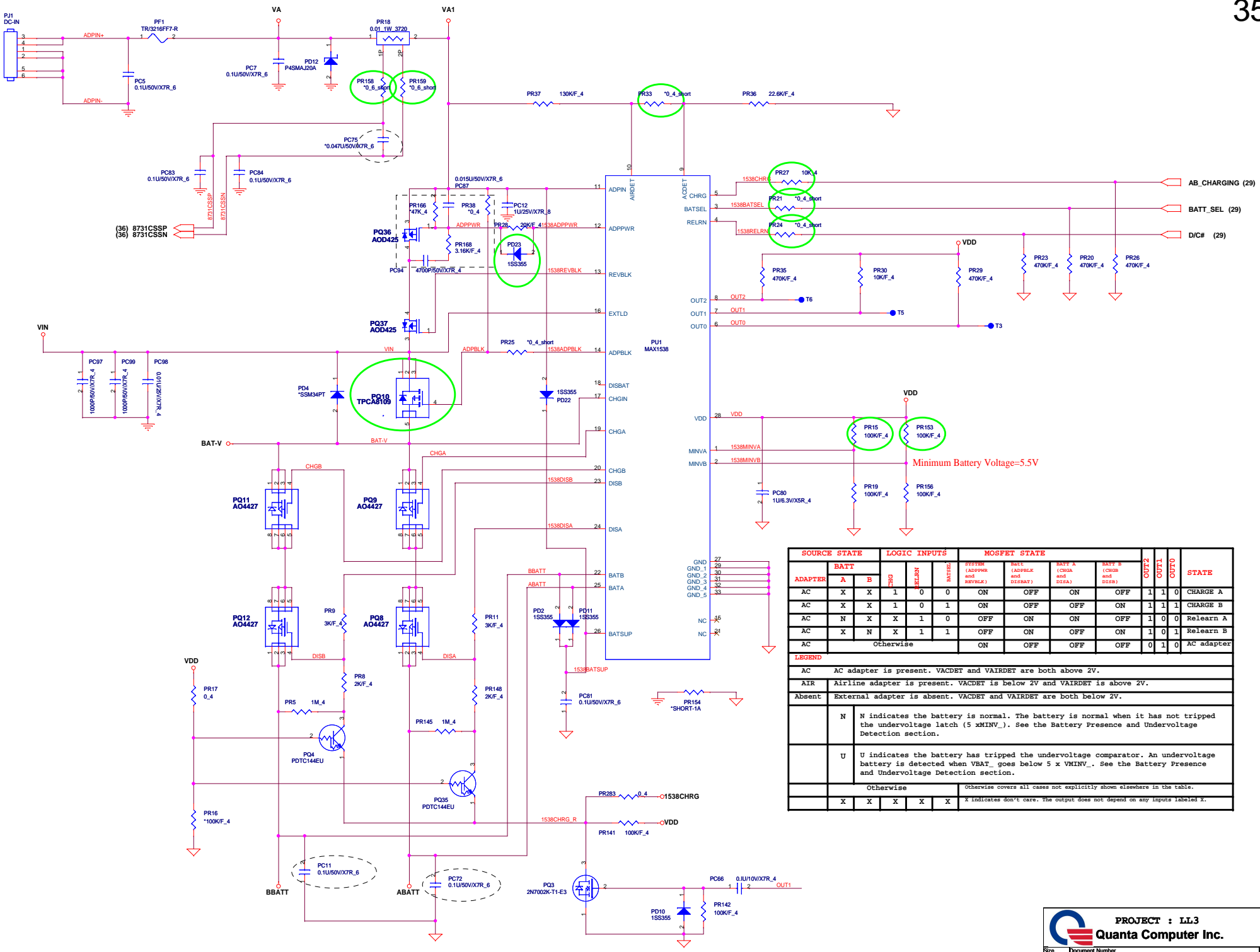

ADAPTER	BATT		LOGIC INPUTS				MOSFET STATE				OUT2	OUT1	STATE
	A	B	CHG	RELE	BATSEL	SYSTEM (ADPPWR and REVBLK)	BATT (ADPBLK and DISBAT)	BATT A (CHGA and DISA)	BATT B (CHGB and DISB)				
AC	X	X	1	0	0	ON	OFF	ON	OFF	1	1	0	CHARGE A
AC	X	X	1	0	1	ON	OFF	OFF	OFF	1	1	1	CHARGE B
AC	N	X	X	1	0	OFF	ON	ON	OFF	1	0	0	Relearn A
AC	X	N	X	1	1	OFF	ON	OFF	ON	1	0	1	Relearn B
AC	Otherwise					ON	OFF	OFF	OFF	0	1	0	AC adapter
LEGEND													
AC	AC adapter is present. VACDET and VAIRDET are both above 2V.												
AIR	Airline adapter is present. VACDET is below 2V and VAIRDET is above 2V.												
Absent	External adapter is absent. VACDET and VAIRDET are both below 2V.												
N	N indicates the battery is normal. The battery is normal when it has not tripped the undervoltage latch (5 xMINV_). See the Battery Presence and Undervoltage Detection section.												
U	U indicates the battery has tripped the undervoltage comparator. An undervoltage battery is detected when VBAT_ goes below 5 x VMINV_ . See the Battery Presence and Undervoltage Detection section.												
Otherwise						Otherwise covers all cases not explicitly shown elsewhere in the table.							
X	X	X	X	X	X	X indicates don't care. The output does not depend on any inputs labeled X.							

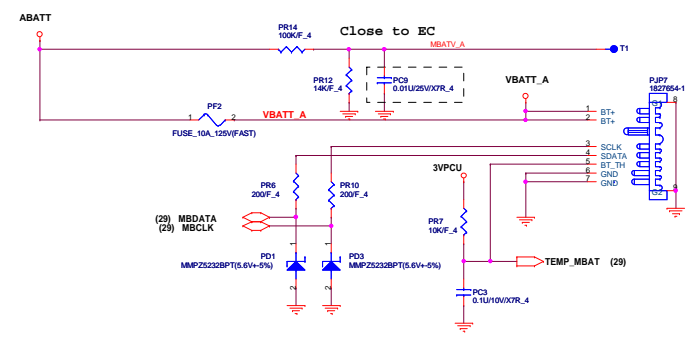
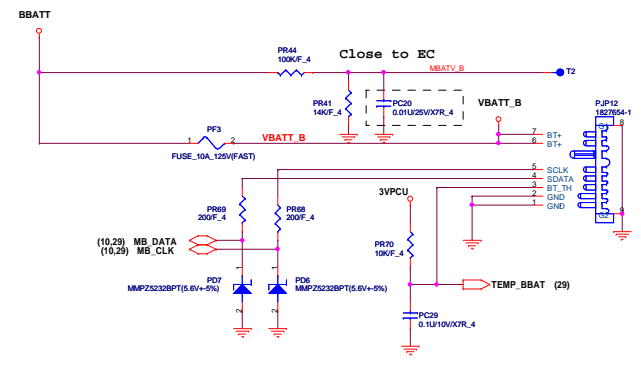
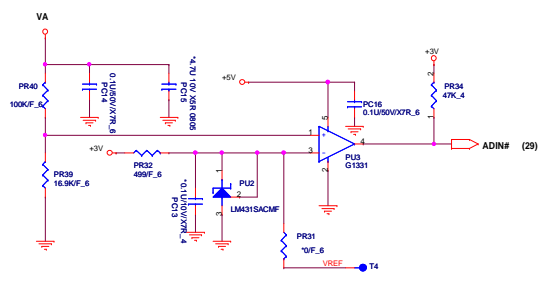
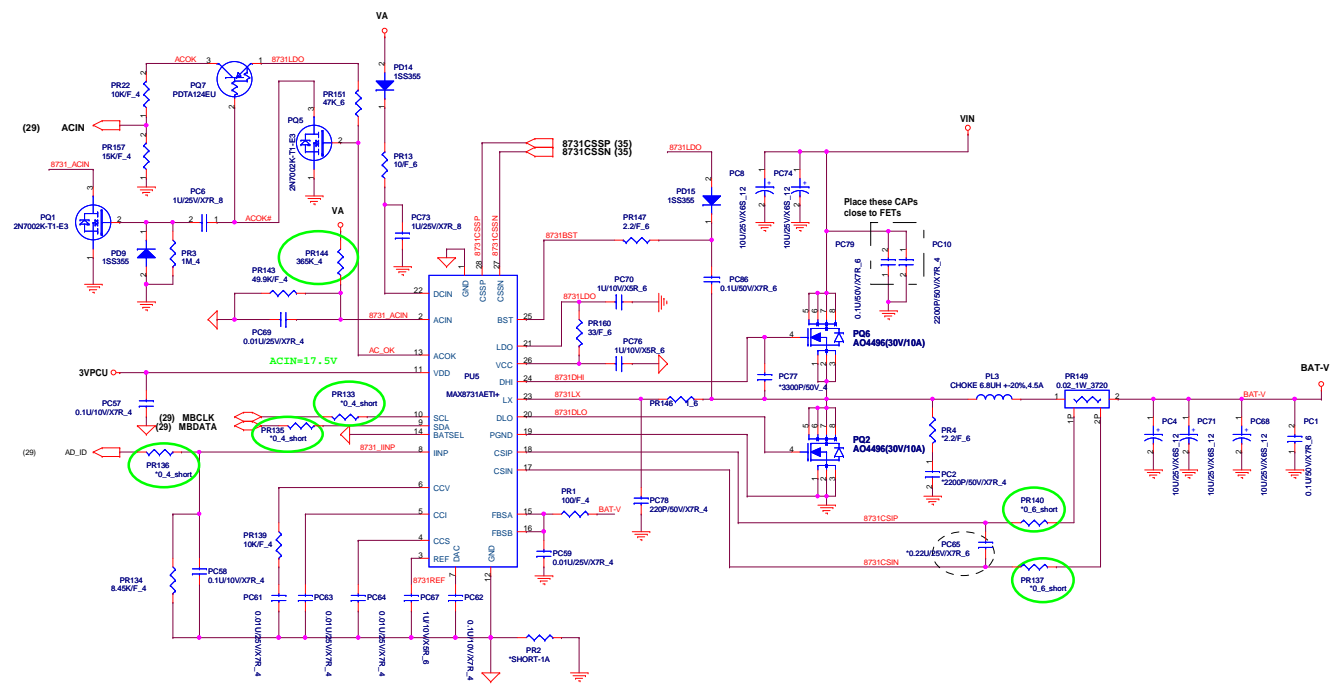

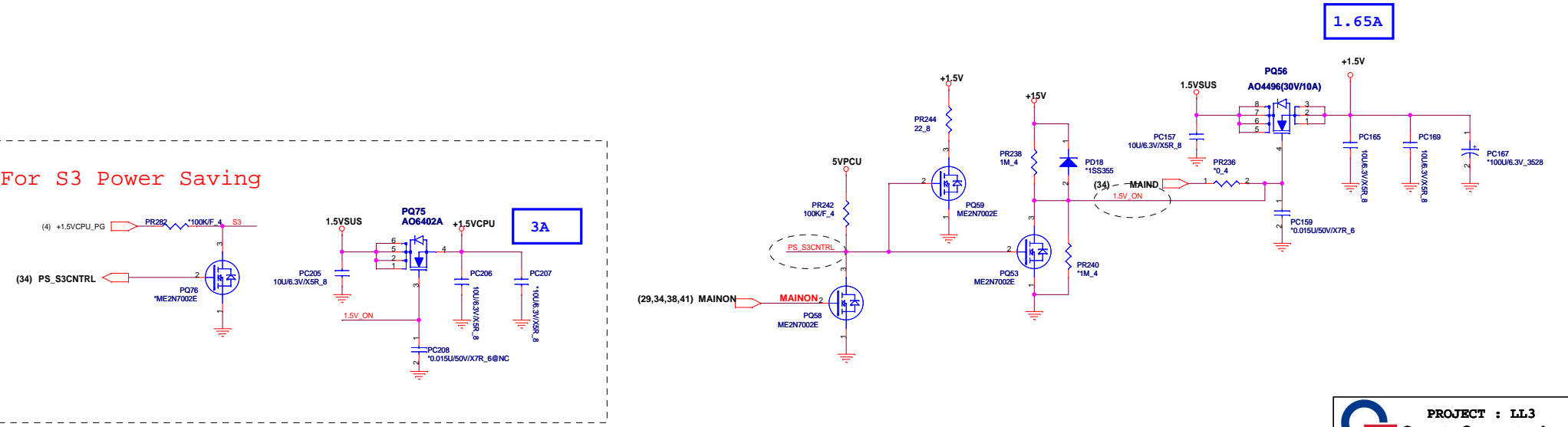
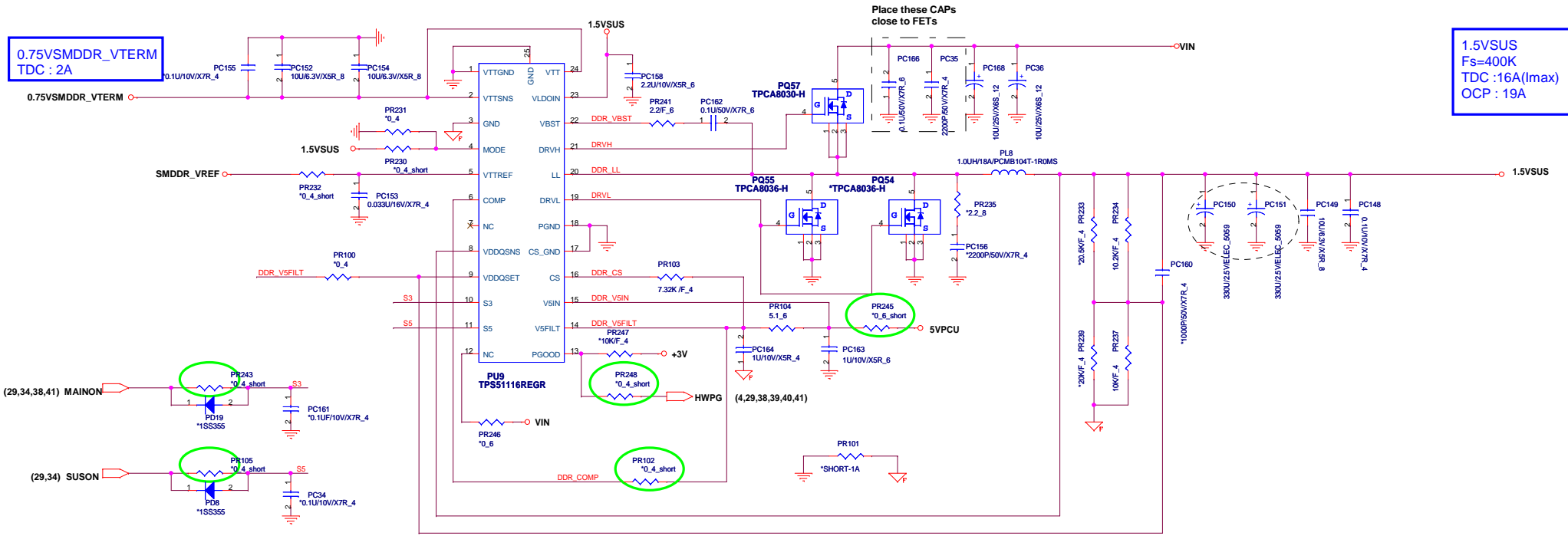

1.65A

For S3 Power Saving

3A

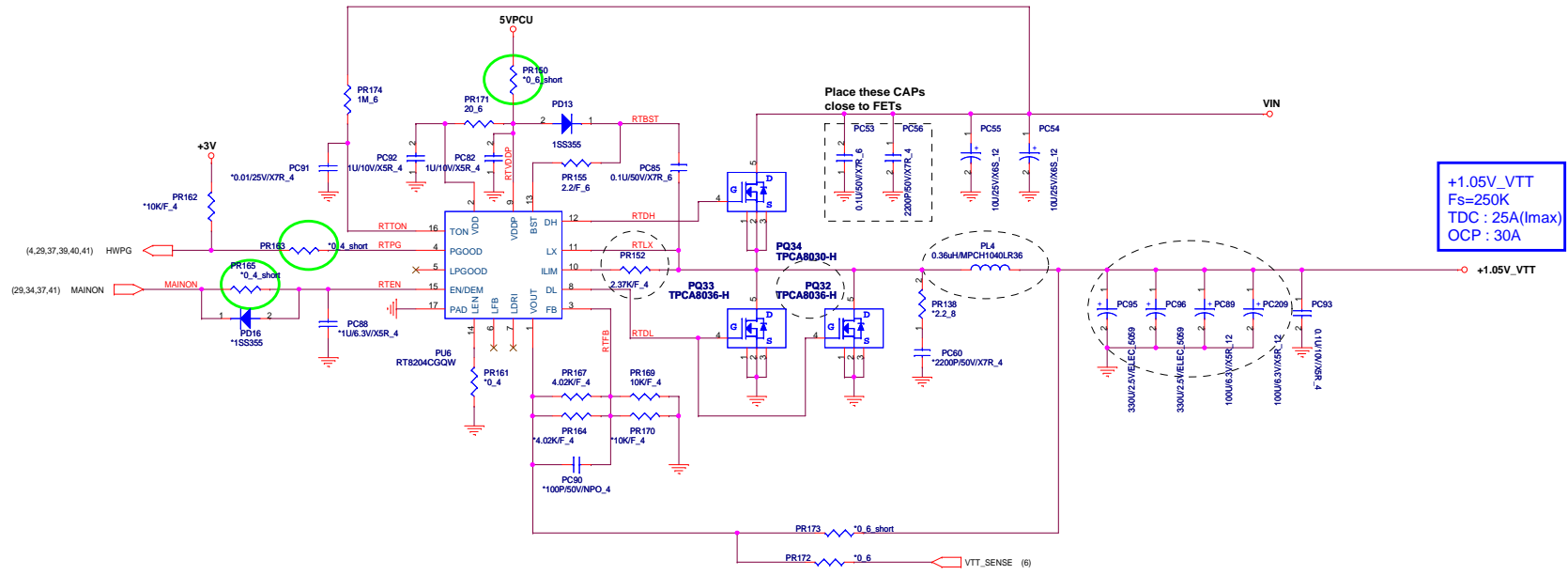

+1.05V_VTT
 Fs=250K
 TDC : 25A(I_{max})
 OCP : 30A

(9,16,19,22,29,30,31,34,36,41) 3VPCU
(9,22,34,37,38,41) 5VPCU
(16,22,34,37) +15V
(16,33,35,36,37,38,40,41) VIN

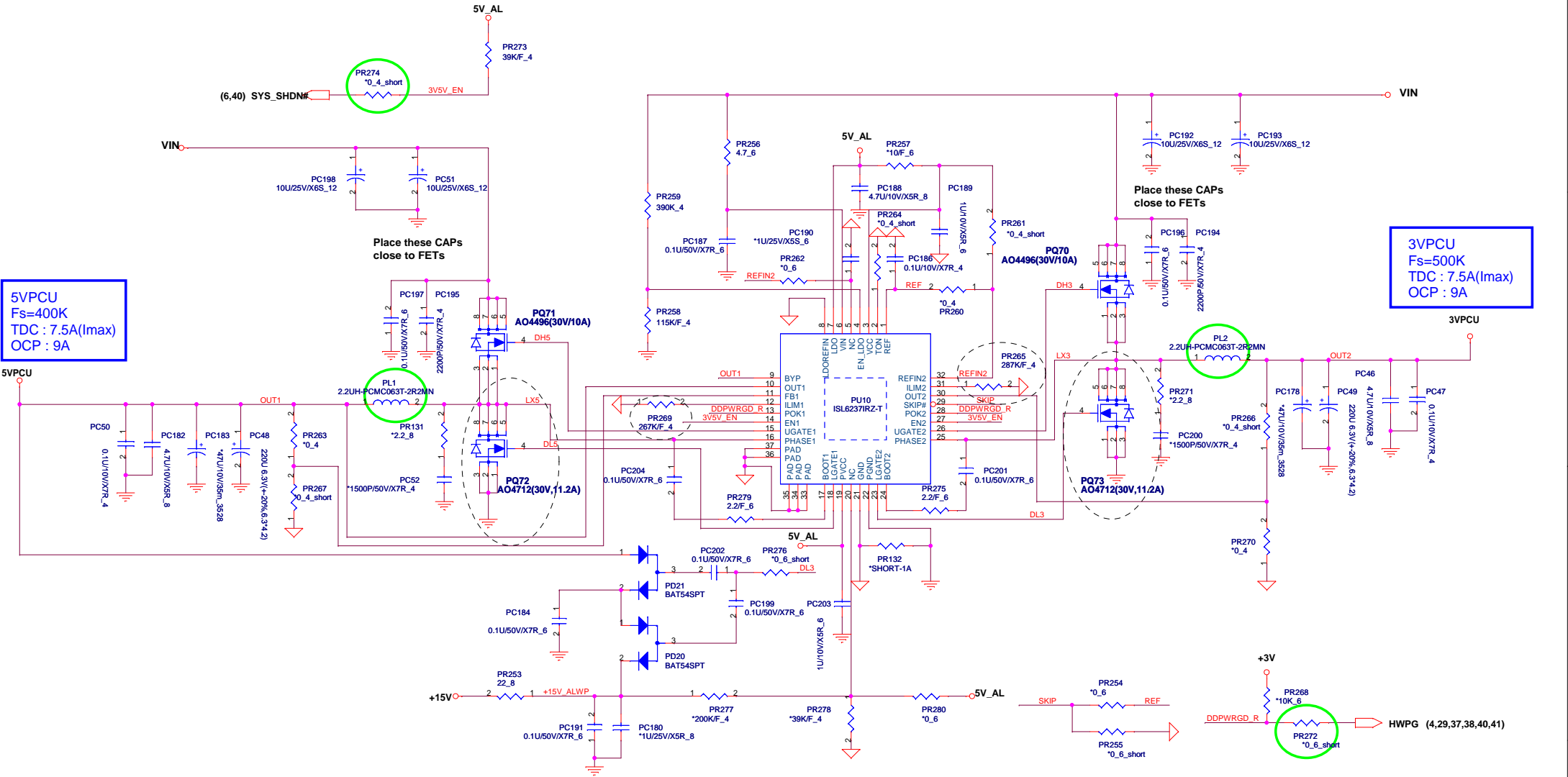

PROJECT : LL3
Quanta Computer Inc.

Size Custom	Document Number 3V/5V (ISL6237IRZ-T)	Rev 1A
Date: Wednesday, October 21, 2009	Sheet 39	of 42

