

POTOMAC 10G

CS BUILD

2008.1.21

6050A2171501

DRAWER	EE	DATE	POWER	DATE	INVENTEC
DESIGN					
CHECK					
RESPONSIBLE					
TITLE					<i>Potomac 10G</i>
SIZE =	3	VER :			SIZE
FILE NAME :	XXXX-XXXXXX-XX				A3 CS
P/N	XXXXXXXXXXXX				DOC. NUMBER
					Model No
					SHEET 1 OF 63
					REV
					X01

DATE	CHANGE NO.	REV

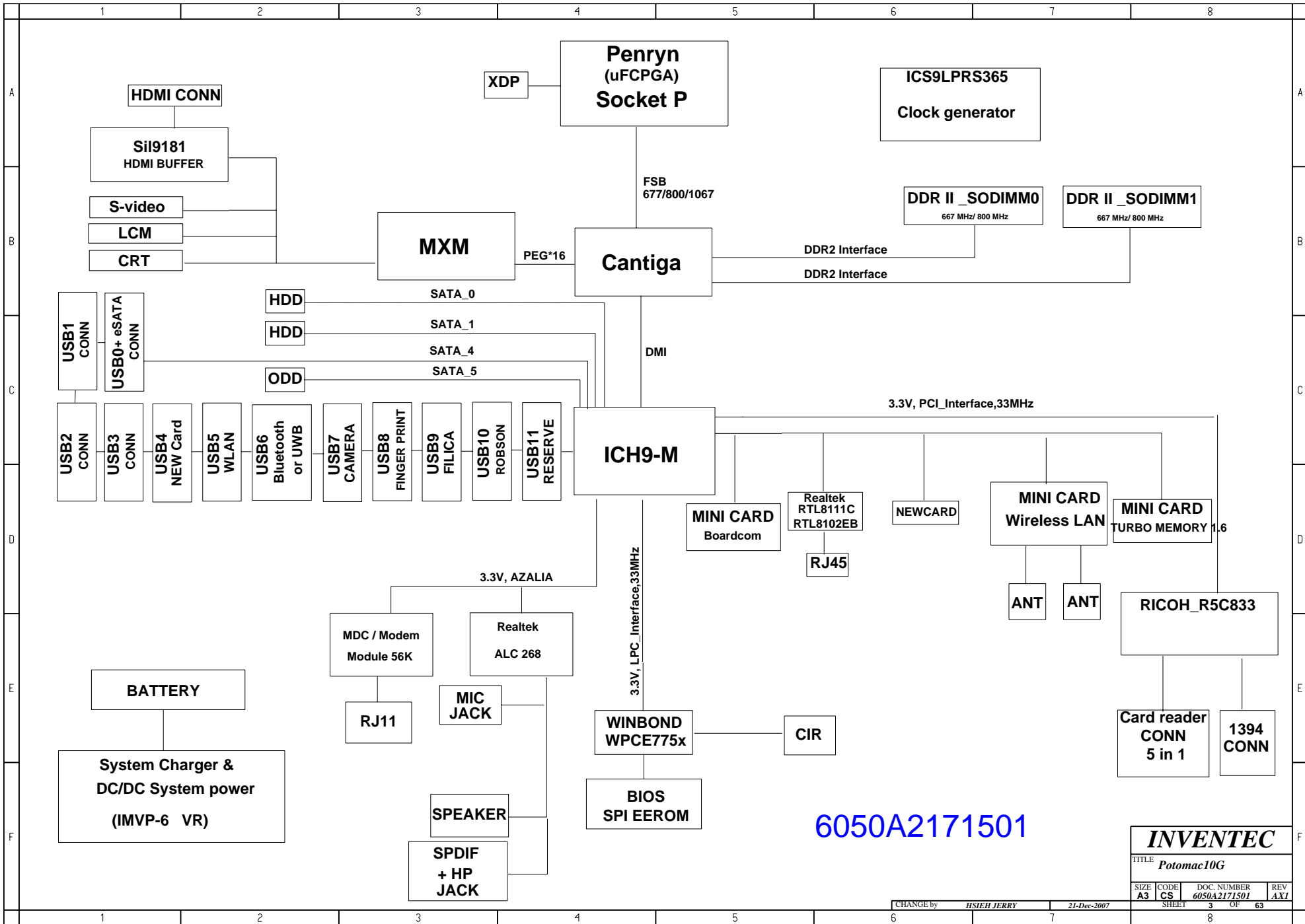

6050A2171501

INVENTEC

TITLE Potomac10G

SIZE	CODE	DOC. NUMBER	REV
A3	CS	6050A2171501	AXI

CHANGE by HSEH JERRY 21-Dec-2007

SHEET 3 OF 63

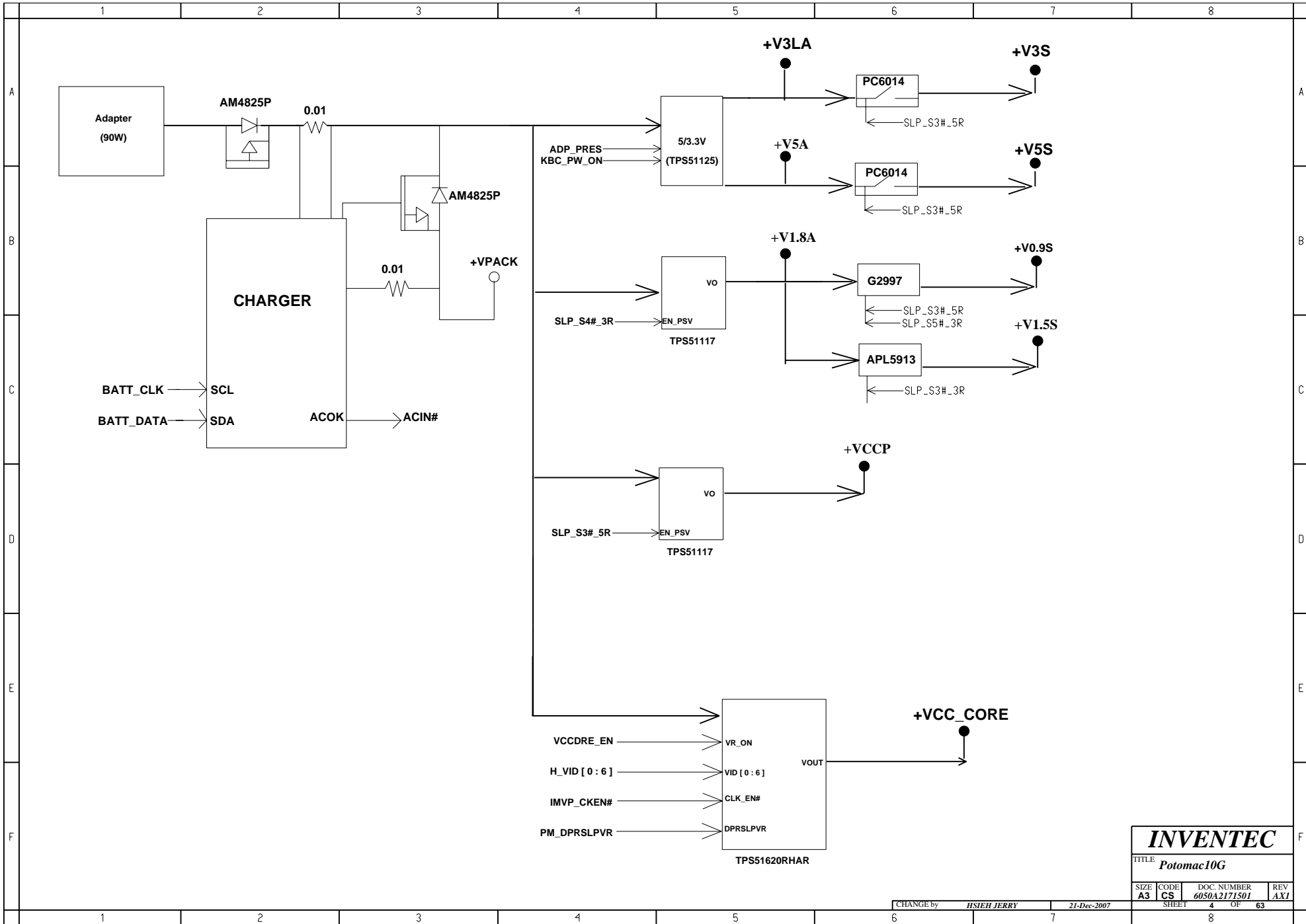

INVENTEC			
TITLE Potomac10G			
SIZE A3	CODE CS	DOC. NUMBER 6050A2171501	REV AX1
CHANGE by HSEH JERRY		21-Dec-2007	
SHEET 4		OF 63	

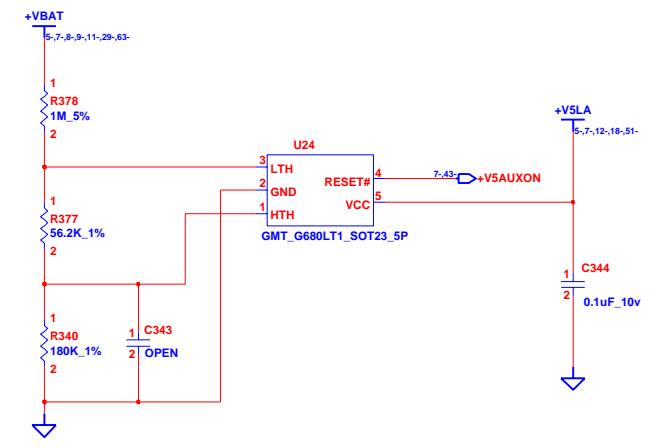
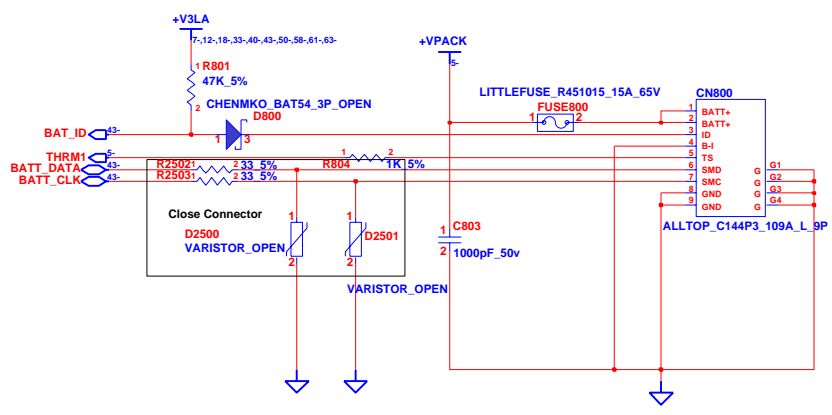

INVENTEC			
TITLE			
<i>SELECT & BATTERY CONN</i>			
SIZE	CODE	DOC. NUMBER	REV
A3	CS	6050A2171501	AX1
CHANGE by		DATE	SHEET
HSHIEH JERRY		21-Dec-2007	6 OF 63
1	2	3	8

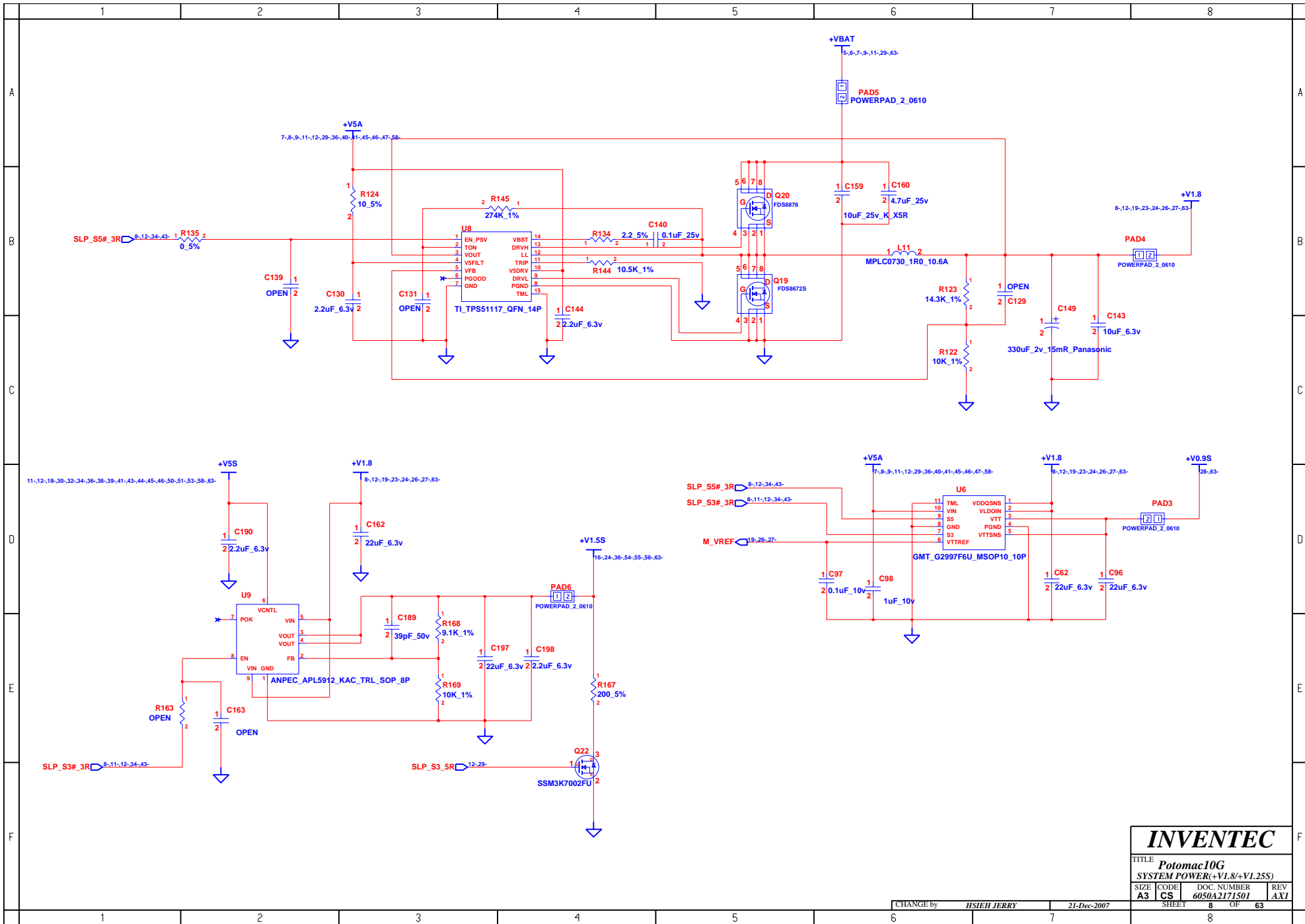

INVENTEC

TITLE
Potomac10G
 SYSTEM POWER(+V1.8/+V1.25S)

SIZE A3	CODE CS	DOC. NUMBER 6050A2171501	REV AX1
------------	------------	-----------------------------	------------

CHANGE by HSEH JERRY 21-Dec-2007

SHEET 8 OF 63

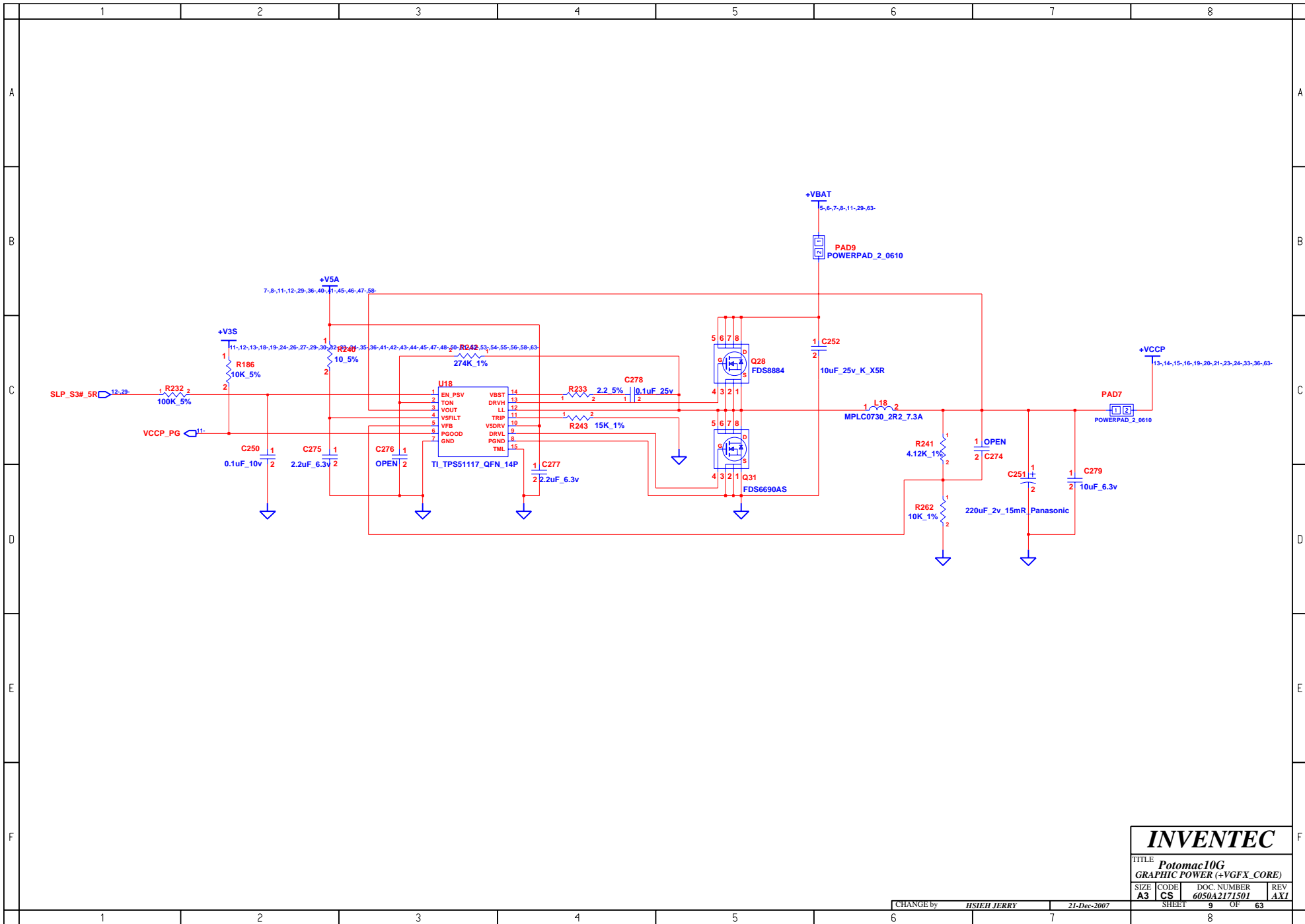

INVENTEC

TITLE
Potomac10G
GRAPHIC POWER (+VGF_XCORE)

SIZE A3	CODE CS	DOC. NUMBER 6050A2171501	REV AXI
-------------------	-------------------	------------------------------------	-------------------

CHANGE by HSEH JERRY	21-Dec-2007	SHEET 9	OF 63
--------------------------------	--------------------	-------------------	-----------------

BLANK

INVENTEC			
TITLE Potomac10G			
SYSTEM POWER(+VCCP/A-V1.5S)			
SIZE	CODE	DOC. NUMBER	REV
A3	CS	6050A2171501	AX1
CHANGE by HSEH JERRY		21-Dec-2007	SHEET 10 OF 63

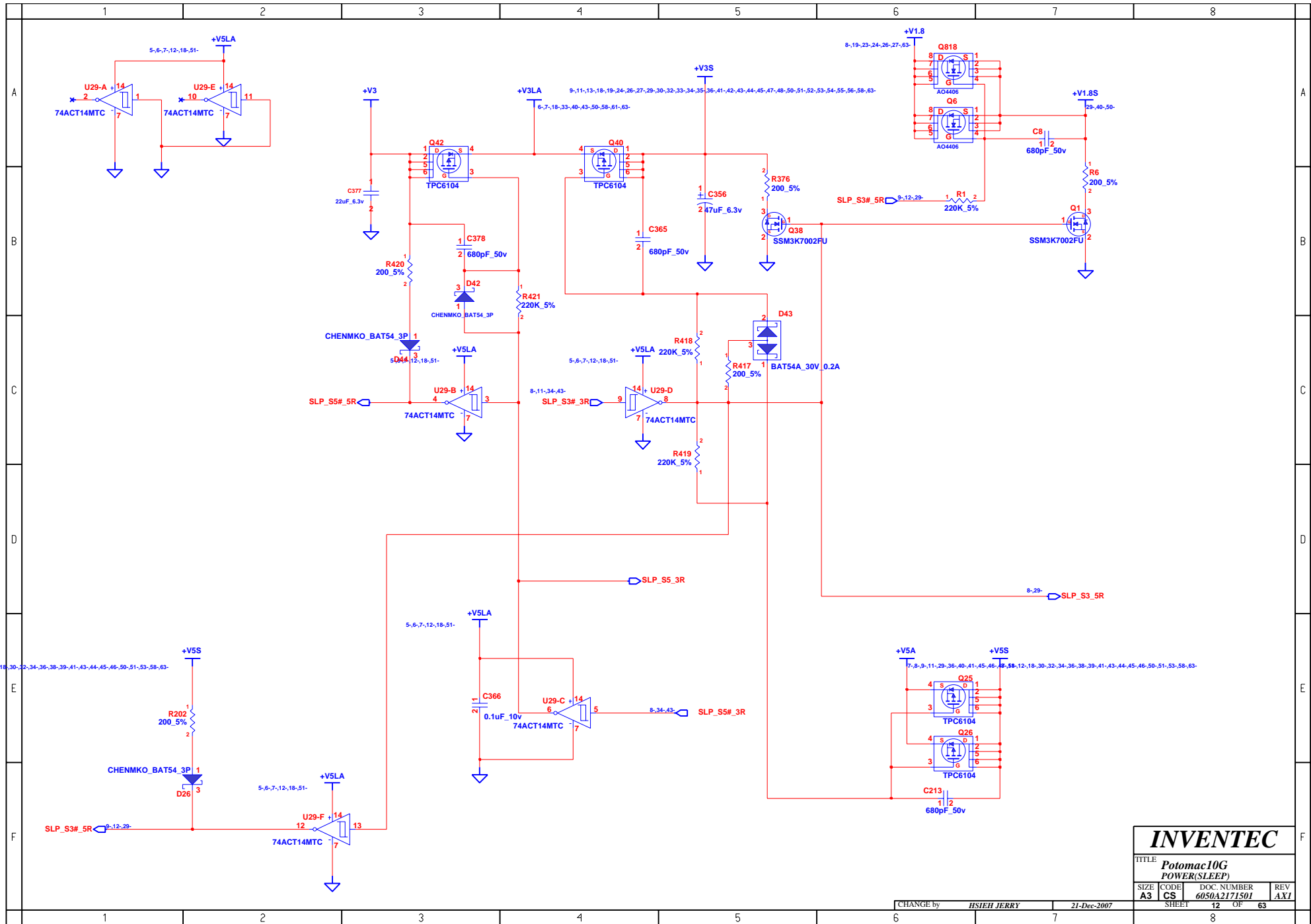

INVENTEC			
TITLE Potomac10G POWER(SLEEP)			
SIZE A3	CODE CS	DOC. NUMBER 6050A2171501	REV AX1
CHANGE by HSIEH JERRY		21-Dec-2007	SHEET 12 OF 63

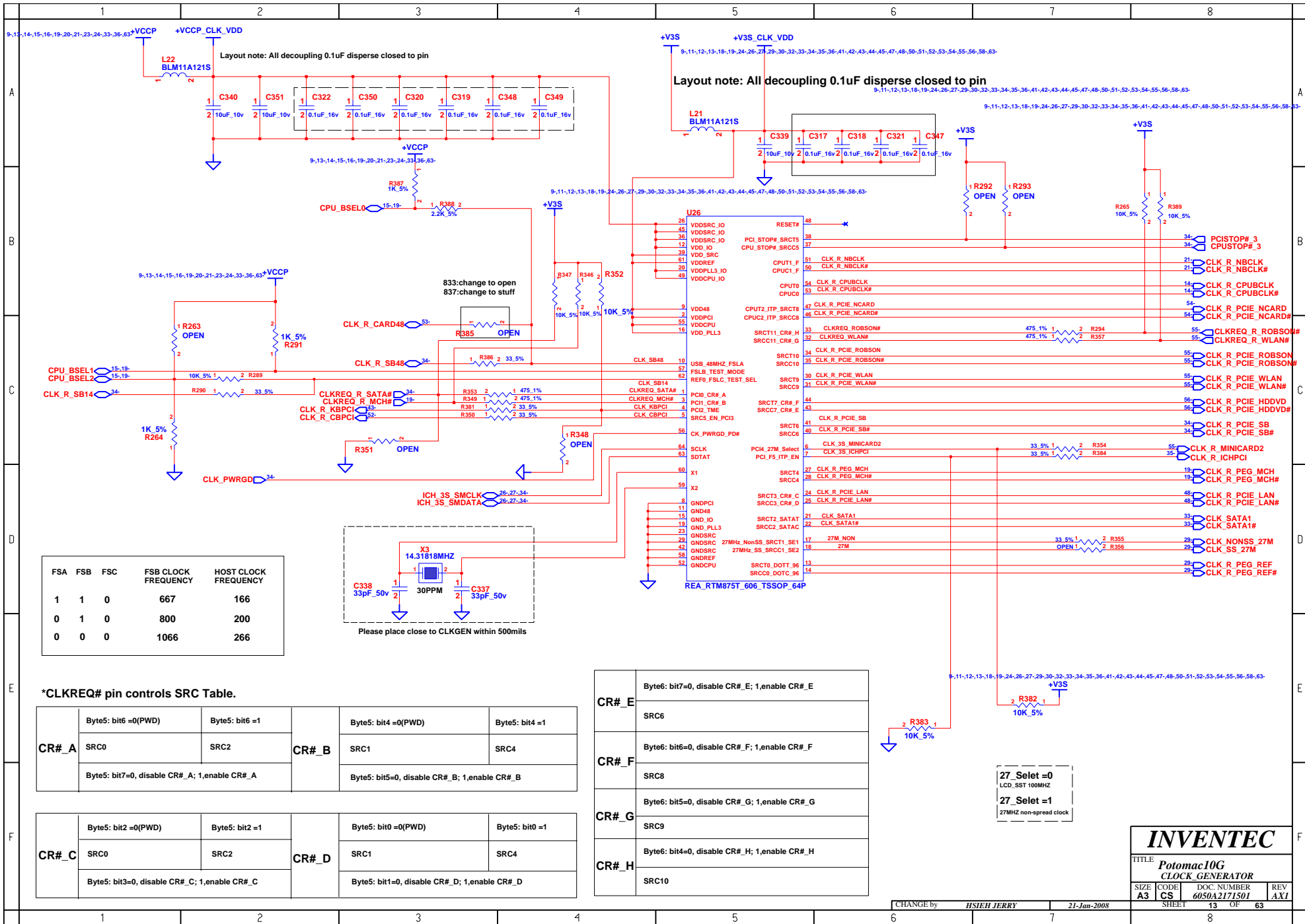

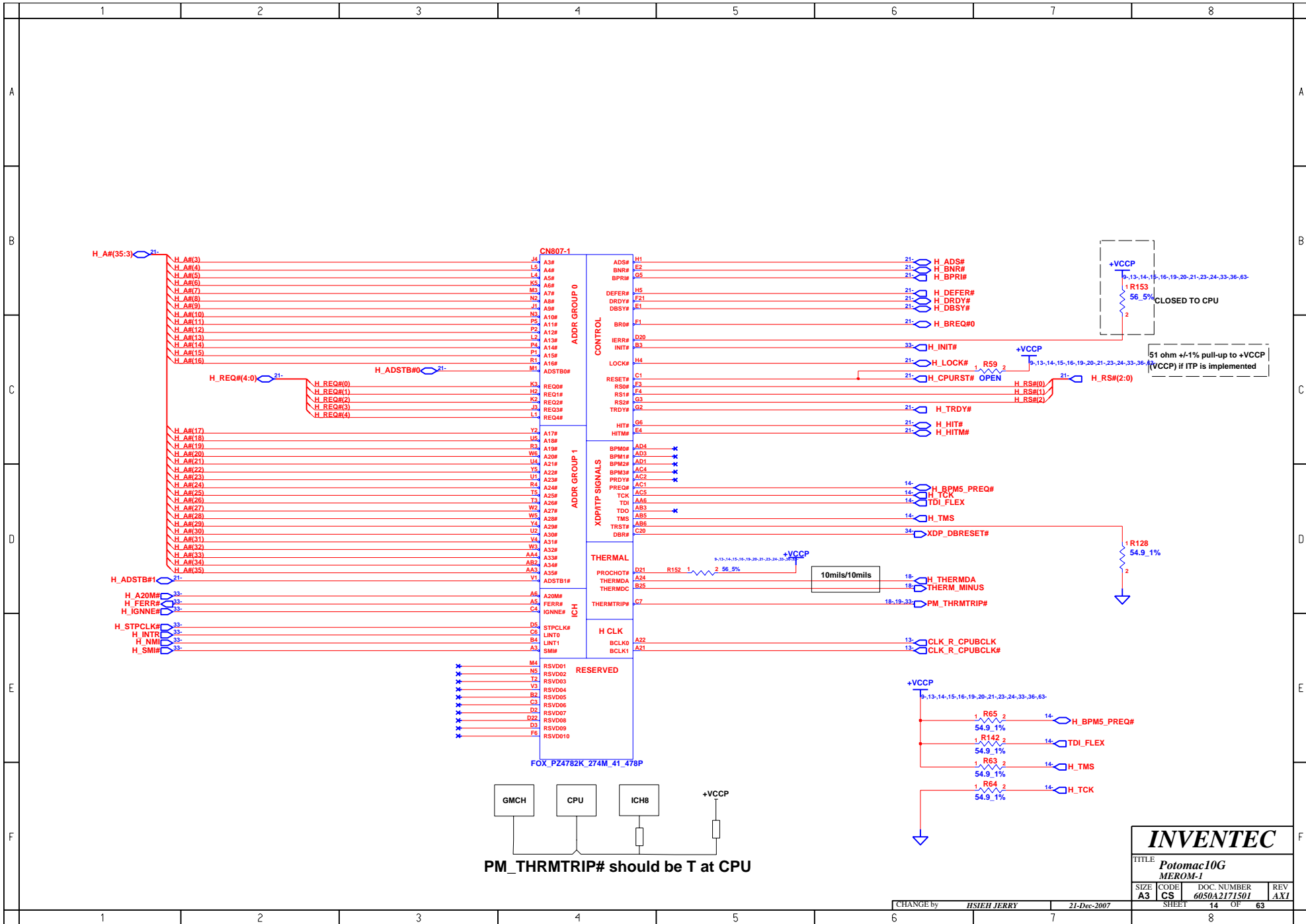

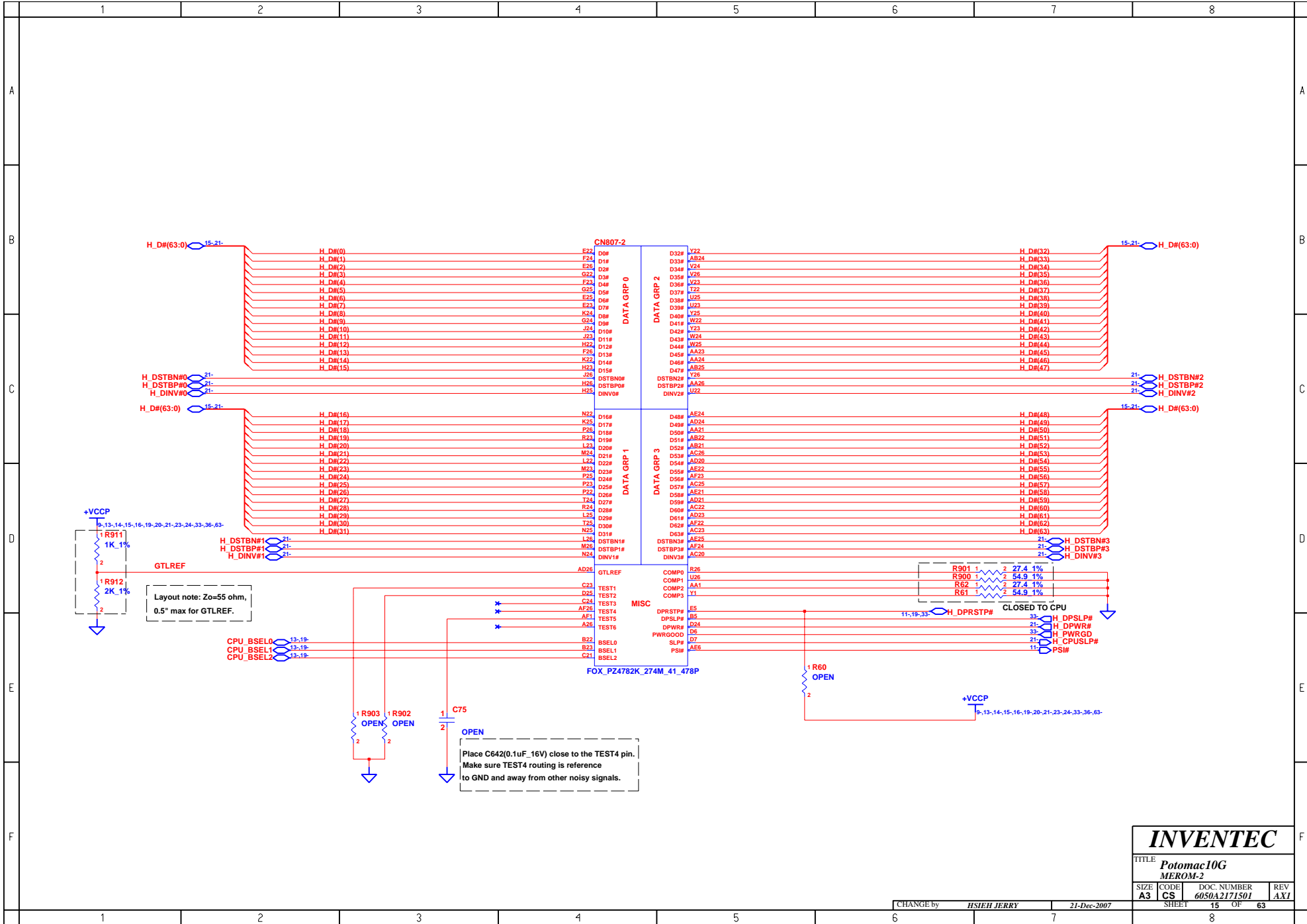

INVENTEC			
TITLE Potomac10G			
MEROM-2			
SIZE A3	CODE CS	DOC. NUMBER 6050A2171501	REV AX1
CHANGE by HSEIH JERRY		21-Dec-2007	
SHEET 15		OF 63	

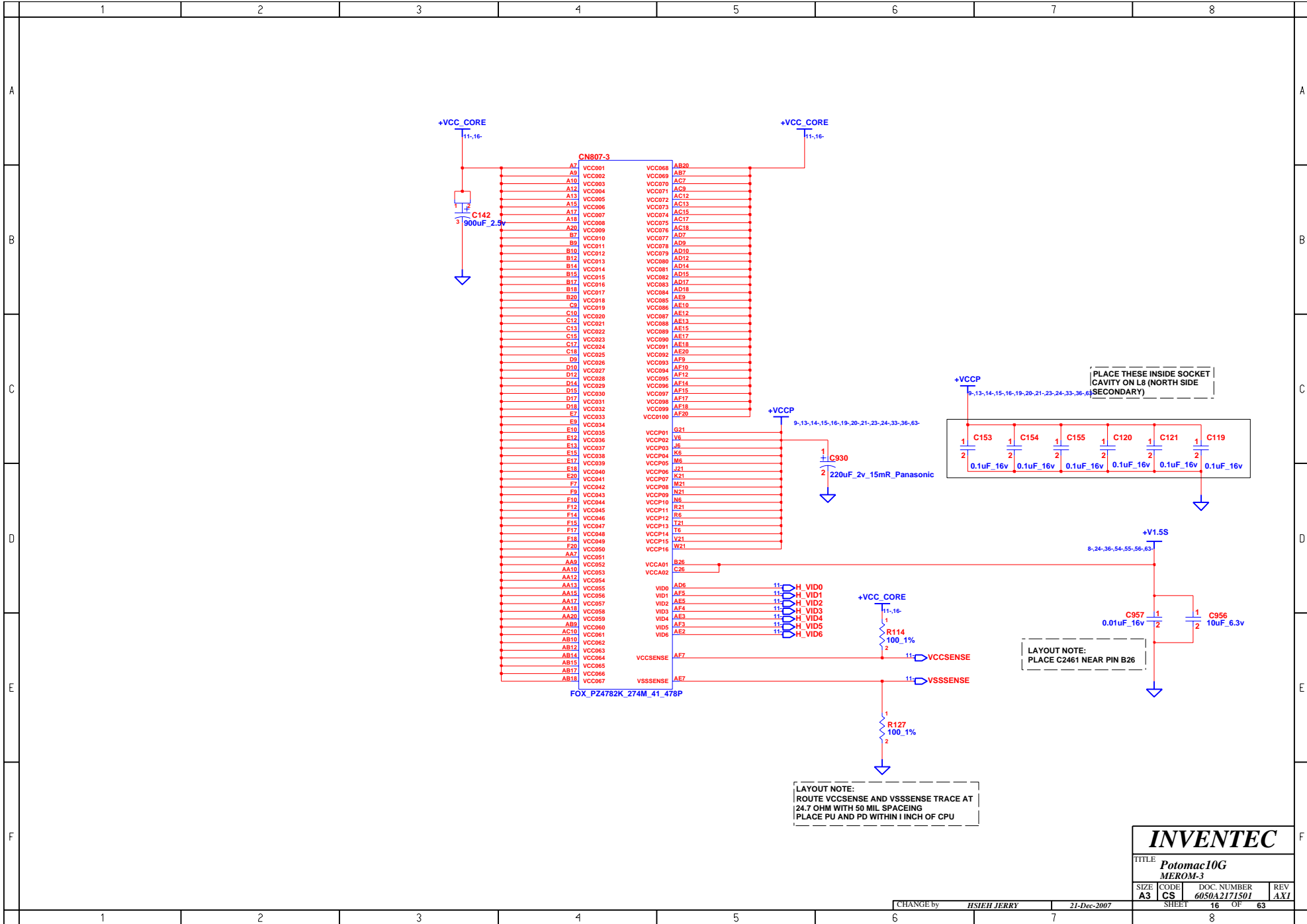

PLACE THESE INSIDE SOCKET
CAVITY ON L8 (NORTH SIDE
SECONDARY)

LAYOUT NOTE:
PLACE C2461 NEAR PIN B26

LAYOUT NOTE:
ROUTE VCCSENSE AND VSSSENSE TRACE AT
24.7 OHM WITH 50 MIL SPACING
PLACE PU AND PD WITHIN 1 INCH OF CPU

INVENTEC

TITLE			
Potomac10G MEROM-3			
SIZE	CODE	DOC. NUMBER	REV
A3	CS	6050A2171501	AX1
CHANGE by		SHEET	
HSEIH JERRY		16 OF 63	

	1	2	3	4	5	6	7	8																																																																																																																																																																																																																																																																																																																																									
A	<p style="color: red; font-weight: bold;">CN807-4</p> <table border="1" style="margin: auto; border-collapse: collapse;"> <tr><td style="color: red;">A4</td><td>VSS001</td><td>VSS002</td><td>P6</td></tr> <tr><td style="color: red;">A8</td><td>VSS002</td><td>VSS003</td><td>P21</td></tr> <tr><td style="color: red;">A11</td><td>VSS003</td><td>VSS004</td><td>P24</td></tr> <tr><td style="color: red;">A14</td><td>VSS004</td><td>VSS005</td><td>R2</td></tr> <tr><td style="color: red;">A16</td><td>VSS005</td><td>VSS006</td><td>R5</td></tr> <tr><td style="color: red;">A19</td><td>VSS006</td><td>VSS007</td><td>R22</td></tr> <tr><td style="color: red;">A23</td><td>VSS007</td><td>VSS008</td><td>R25</td></tr> <tr><td style="color: red;">AF2</td><td>VSS008</td><td>VSS009</td><td>T1</td></tr> <tr><td style="color: red;">B6</td><td>VSS009</td><td>VSS010</td><td>T4</td></tr> <tr><td style="color: red;">B8</td><td>VSS010</td><td>VSS011</td><td>T23</td></tr> <tr><td style="color: red;">B11</td><td>VSS011</td><td>VSS012</td><td>T28</td></tr> <tr><td style="color: red;">B13</td><td>VSS012</td><td>VSS013</td><td>U3</td></tr> <tr><td style="color: red;">B16</td><td>VSS013</td><td>VSS014</td><td>U6</td></tr> <tr><td style="color: red;">B19</td><td>VSS014</td><td>VSS015</td><td>U21</td></tr> <tr><td style="color: red;">B21</td><td>VSS015</td><td>VSS016</td><td>U24</td></tr> <tr><td style="color: red;">B24</td><td>VSS016</td><td>VSS017</td><td>V2</td></tr> <tr><td style="color: red;">C5</td><td>VSS017</td><td>VSS018</td><td>V5</td></tr> <tr><td style="color: red;">C8</td><td>VSS018</td><td>VSS019</td><td>V22</td></tr> <tr><td style="color: red;">C11</td><td>VSS019</td><td>VSS020</td><td>V25</td></tr> <tr><td style="color: red;">C14</td><td>VSS020</td><td>VSS021</td><td>W1</td></tr> <tr><td style="color: red;">C16</td><td>VSS021</td><td>VSS022</td><td>W4</td></tr> <tr><td style="color: red;">C19</td><td>VSS022</td><td>VSS023</td><td>W23</td></tr> <tr><td style="color: red;">C2</td><td>VSS023</td><td>VSS024</td><td>W26</td></tr> <tr><td style="color: red;">C22</td><td>VSS024</td><td>VSS025</td><td>Y3</td></tr> <tr><td style="color: red;">C25</td><td>VSS025</td><td>VSS026</td><td>Y6</td></tr> <tr><td style="color: red;">D1</td><td>VSS026</td><td>VSS027</td><td>Y21</td></tr> <tr><td style="color: red;">D4</td><td>VSS027</td><td>VSS028</td><td>Y24</td></tr> <tr><td style="color: red;">D8</td><td>VSS028</td><td>VSS029</td><td>AA2</td></tr> <tr><td style="color: red;">D11</td><td>VSS029</td><td>VSS030</td><td>AA5</td></tr> <tr><td style="color: red;">D13</td><td>VSS030</td><td>VSS031</td><td>AA8</td></tr> <tr><td style="color: red;">D16</td><td>VSS031</td><td>VSS032</td><td>AA11</td></tr> <tr><td style="color: red;">D19</td><td>VSS032</td><td>VSS033</td><td>AA14</td></tr> <tr><td style="color: red;">D23</td><td>VSS033</td><td>VSS034</td><td>AA16</td></tr> <tr><td style="color: red;">D26</td><td>VSS034</td><td>VSS035</td><td>AA19</td></tr> <tr><td style="color: red;">E3</td><td>VSS035</td><td>VSS036</td><td>AA22</td></tr> <tr><td style="color: red;">E6</td><td>VSS036</td><td>VSS037</td><td>AA25</td></tr> <tr><td style="color: red;">E8</td><td>VSS037</td><td>VSS038</td><td>AB1</td></tr> <tr><td style="color: red;">E11</td><td>VSS038</td><td>VSS039</td><td>AB4</td></tr> <tr><td style="color: red;">E14</td><td>VSS039</td><td>VSS040</td><td>AB8</td></tr> <tr><td style="color: red;">E16</td><td>VSS040</td><td>VSS041</td><td>AB11</td></tr> <tr><td style="color: red;">E19</td><td>VSS041</td><td>VSS042</td><td>AB13</td></tr> <tr><td style="color: red;">E21</td><td>VSS042</td><td>VSS043</td><td>AB16</td></tr> <tr><td style="color: red;">E24</td><td>VSS043</td><td>VSS044</td><td>AB18</td></tr> <tr><td style="color: red;">F5</td><td>VSS044</td><td>VSS045</td><td>AB23</td></tr> <tr><td style="color: red;">F8</td><td>VSS045</td><td>VSS046</td><td>AB26</td></tr> <tr><td style="color: red;">F11</td><td>VSS046</td><td>VSS047</td><td>AC3</td></tr> <tr><td style="color: red;">F13</td><td>VSS047</td><td>VSS048</td><td>AC6</td></tr> <tr><td style="color: red;">F16</td><td>VSS048</td><td>VSS049</td><td>AC8</td></tr> <tr><td style="color: red;">F19</td><td>VSS049</td><td>VSS050</td><td>AC11</td></tr> <tr><td style="color: red;">F2</td><td>VSS050</td><td>VSS051</td><td>AC14</td></tr> <tr><td style="color: red;">F22</td><td>VSS051</td><td>VSS052</td><td>AC16</td></tr> <tr><td style="color: red;">F25</td><td>VSS052</td><td>VSS053</td><td>AC19</td></tr> <tr><td style="color: red;">G4</td><td>VSS053</td><td>VSS054</td><td>AC21</td></tr> <tr><td style="color: red;">G1</td><td>VSS054</td><td>VSS055</td><td>AC24</td></tr> <tr><td style="color: red;">G23</td><td>VSS055</td><td>VSS056</td><td>AD2</td></tr> <tr><td style="color: red;">G26</td><td>VSS056</td><td>VSS057</td><td>AD5</td></tr> <tr><td style="color: red;">H3</td><td>VSS057</td><td>VSS058</td><td>AD8</td></tr> <tr><td style="color: red;">H6</td><td>VSS058</td><td>VSS059</td><td>AD11</td></tr> <tr><td style="color: red;">H21</td><td>VSS059</td><td>VSS060</td><td>AD13</td></tr> <tr><td style="color: red;">H24</td><td>VSS060</td><td>VSS061</td><td>AD16</td></tr> <tr><td style="color: red;">J4</td><td>VSS061</td><td>VSS062</td><td>AD19</td></tr> <tr><td style="color: red;">J5</td><td>VSS062</td><td>VSS063</td><td>AD22</td></tr> <tr><td style="color: red;">J22</td><td>VSS063</td><td>VSS064</td><td>AD25</td></tr> <tr><td style="color: red;">J25</td><td>VSS064</td><td>VSS065</td><td>AE1</td></tr> <tr><td style="color: red;">K1</td><td>VSS065</td><td>VSS066</td><td>AE4</td></tr> <tr><td style="color: red;">K4</td><td>VSS066</td><td>VSS067</td><td>AE8</td></tr> <tr><td style="color: red;">K23</td><td>VSS067</td><td>VSS068</td><td>AE11</td></tr> <tr><td style="color: red;">K26</td><td>VSS068</td><td>VSS069</td><td>AE14</td></tr> <tr><td style="color: red;">L3</td><td>VSS069</td><td>VSS070</td><td>AE16</td></tr> <tr><td style="color: red;">L6</td><td>VSS070</td><td>VSS071</td><td>AE19</td></tr> <tr><td style="color: red;">L21</td><td>VSS071</td><td>VSS072</td><td>AE23</td></tr> <tr><td style="color: red;">L24</td><td>VSS072</td><td>VSS073</td><td>AE26</td></tr> <tr><td style="color: red;">M2</td><td>VSS073</td><td>VSS074</td><td>AF</td></tr> <tr><td style="color: red;">M5</td><td>VSS074</td><td>VSS075</td><td>AF6</td></tr> <tr><td style="color: red;">M22</td><td>VSS075</td><td>VSS076</td><td>AF8</td></tr> <tr><td style="color: red;">M25</td><td>VSS076</td><td>VSS077</td><td>AF11</td></tr> <tr><td style="color: red;">N1</td><td>VSS077</td><td>VSS078</td><td>AF13</td></tr> <tr><td style="color: red;">N4</td><td>VSS078</td><td>VSS079</td><td>AF16</td></tr> <tr><td style="color: red;">N23</td><td>VSS079</td><td>VSS080</td><td>AF19</td></tr> <tr><td style="color: red;">N26</td><td>VSS080</td><td>VSS081</td><td>AF21</td></tr> <tr><td style="color: red;">P3</td><td>VSS081</td><td></td><td>AF25</td></tr> <tr><td style="color: red;">P6</td><td></td><td></td><td>AF25</td></tr> </table> <p style="color: blue; font-weight: bold; text-align: center;">FOX_PZ4782K_274M_41_478P</p>									A4	VSS001	VSS002	P6	A8	VSS002	VSS003	P21	A11	VSS003	VSS004	P24	A14	VSS004	VSS005	R2	A16	VSS005	VSS006	R5	A19	VSS006	VSS007	R22	A23	VSS007	VSS008	R25	AF2	VSS008	VSS009	T1	B6	VSS009	VSS010	T4	B8	VSS010	VSS011	T23	B11	VSS011	VSS012	T28	B13	VSS012	VSS013	U3	B16	VSS013	VSS014	U6	B19	VSS014	VSS015	U21	B21	VSS015	VSS016	U24	B24	VSS016	VSS017	V2	C5	VSS017	VSS018	V5	C8	VSS018	VSS019	V22	C11	VSS019	VSS020	V25	C14	VSS020	VSS021	W1	C16	VSS021	VSS022	W4	C19	VSS022	VSS023	W23	C2	VSS023	VSS024	W26	C22	VSS024	VSS025	Y3	C25	VSS025	VSS026	Y6	D1	VSS026	VSS027	Y21	D4	VSS027	VSS028	Y24	D8	VSS028	VSS029	AA2	D11	VSS029	VSS030	AA5	D13	VSS030	VSS031	AA8	D16	VSS031	VSS032	AA11	D19	VSS032	VSS033	AA14	D23	VSS033	VSS034	AA16	D26	VSS034	VSS035	AA19	E3	VSS035	VSS036	AA22	E6	VSS036	VSS037	AA25	E8	VSS037	VSS038	AB1	E11	VSS038	VSS039	AB4	E14	VSS039	VSS040	AB8	E16	VSS040	VSS041	AB11	E19	VSS041	VSS042	AB13	E21	VSS042	VSS043	AB16	E24	VSS043	VSS044	AB18	F5	VSS044	VSS045	AB23	F8	VSS045	VSS046	AB26	F11	VSS046	VSS047	AC3	F13	VSS047	VSS048	AC6	F16	VSS048	VSS049	AC8	F19	VSS049	VSS050	AC11	F2	VSS050	VSS051	AC14	F22	VSS051	VSS052	AC16	F25	VSS052	VSS053	AC19	G4	VSS053	VSS054	AC21	G1	VSS054	VSS055	AC24	G23	VSS055	VSS056	AD2	G26	VSS056	VSS057	AD5	H3	VSS057	VSS058	AD8	H6	VSS058	VSS059	AD11	H21	VSS059	VSS060	AD13	H24	VSS060	VSS061	AD16	J4	VSS061	VSS062	AD19	J5	VSS062	VSS063	AD22	J22	VSS063	VSS064	AD25	J25	VSS064	VSS065	AE1	K1	VSS065	VSS066	AE4	K4	VSS066	VSS067	AE8	K23	VSS067	VSS068	AE11	K26	VSS068	VSS069	AE14	L3	VSS069	VSS070	AE16	L6	VSS070	VSS071	AE19	L21	VSS071	VSS072	AE23	L24	VSS072	VSS073	AE26	M2	VSS073	VSS074	AF	M5	VSS074	VSS075	AF6	M22	VSS075	VSS076	AF8	M25	VSS076	VSS077	AF11	N1	VSS077	VSS078	AF13	N4	VSS078	VSS079	AF16	N23	VSS079	VSS080	AF19	N26	VSS080	VSS081	AF21	P3	VSS081		AF25	P6			AF25
A4	VSS001	VSS002	P6																																																																																																																																																																																																																																																																																																																																														
A8	VSS002	VSS003	P21																																																																																																																																																																																																																																																																																																																																														
A11	VSS003	VSS004	P24																																																																																																																																																																																																																																																																																																																																														
A14	VSS004	VSS005	R2																																																																																																																																																																																																																																																																																																																																														
A16	VSS005	VSS006	R5																																																																																																																																																																																																																																																																																																																																														
A19	VSS006	VSS007	R22																																																																																																																																																																																																																																																																																																																																														
A23	VSS007	VSS008	R25																																																																																																																																																																																																																																																																																																																																														
AF2	VSS008	VSS009	T1																																																																																																																																																																																																																																																																																																																																														
B6	VSS009	VSS010	T4																																																																																																																																																																																																																																																																																																																																														
B8	VSS010	VSS011	T23																																																																																																																																																																																																																																																																																																																																														
B11	VSS011	VSS012	T28																																																																																																																																																																																																																																																																																																																																														
B13	VSS012	VSS013	U3																																																																																																																																																																																																																																																																																																																																														
B16	VSS013	VSS014	U6																																																																																																																																																																																																																																																																																																																																														
B19	VSS014	VSS015	U21																																																																																																																																																																																																																																																																																																																																														
B21	VSS015	VSS016	U24																																																																																																																																																																																																																																																																																																																																														
B24	VSS016	VSS017	V2																																																																																																																																																																																																																																																																																																																																														
C5	VSS017	VSS018	V5																																																																																																																																																																																																																																																																																																																																														
C8	VSS018	VSS019	V22																																																																																																																																																																																																																																																																																																																																														
C11	VSS019	VSS020	V25																																																																																																																																																																																																																																																																																																																																														
C14	VSS020	VSS021	W1																																																																																																																																																																																																																																																																																																																																														
C16	VSS021	VSS022	W4																																																																																																																																																																																																																																																																																																																																														
C19	VSS022	VSS023	W23																																																																																																																																																																																																																																																																																																																																														
C2	VSS023	VSS024	W26																																																																																																																																																																																																																																																																																																																																														
C22	VSS024	VSS025	Y3																																																																																																																																																																																																																																																																																																																																														
C25	VSS025	VSS026	Y6																																																																																																																																																																																																																																																																																																																																														
D1	VSS026	VSS027	Y21																																																																																																																																																																																																																																																																																																																																														
D4	VSS027	VSS028	Y24																																																																																																																																																																																																																																																																																																																																														
D8	VSS028	VSS029	AA2																																																																																																																																																																																																																																																																																																																																														
D11	VSS029	VSS030	AA5																																																																																																																																																																																																																																																																																																																																														
D13	VSS030	VSS031	AA8																																																																																																																																																																																																																																																																																																																																														
D16	VSS031	VSS032	AA11																																																																																																																																																																																																																																																																																																																																														
D19	VSS032	VSS033	AA14																																																																																																																																																																																																																																																																																																																																														
D23	VSS033	VSS034	AA16																																																																																																																																																																																																																																																																																																																																														
D26	VSS034	VSS035	AA19																																																																																																																																																																																																																																																																																																																																														
E3	VSS035	VSS036	AA22																																																																																																																																																																																																																																																																																																																																														
E6	VSS036	VSS037	AA25																																																																																																																																																																																																																																																																																																																																														
E8	VSS037	VSS038	AB1																																																																																																																																																																																																																																																																																																																																														
E11	VSS038	VSS039	AB4																																																																																																																																																																																																																																																																																																																																														
E14	VSS039	VSS040	AB8																																																																																																																																																																																																																																																																																																																																														
E16	VSS040	VSS041	AB11																																																																																																																																																																																																																																																																																																																																														
E19	VSS041	VSS042	AB13																																																																																																																																																																																																																																																																																																																																														
E21	VSS042	VSS043	AB16																																																																																																																																																																																																																																																																																																																																														
E24	VSS043	VSS044	AB18																																																																																																																																																																																																																																																																																																																																														
F5	VSS044	VSS045	AB23																																																																																																																																																																																																																																																																																																																																														
F8	VSS045	VSS046	AB26																																																																																																																																																																																																																																																																																																																																														
F11	VSS046	VSS047	AC3																																																																																																																																																																																																																																																																																																																																														
F13	VSS047	VSS048	AC6																																																																																																																																																																																																																																																																																																																																														
F16	VSS048	VSS049	AC8																																																																																																																																																																																																																																																																																																																																														
F19	VSS049	VSS050	AC11																																																																																																																																																																																																																																																																																																																																														
F2	VSS050	VSS051	AC14																																																																																																																																																																																																																																																																																																																																														
F22	VSS051	VSS052	AC16																																																																																																																																																																																																																																																																																																																																														
F25	VSS052	VSS053	AC19																																																																																																																																																																																																																																																																																																																																														
G4	VSS053	VSS054	AC21																																																																																																																																																																																																																																																																																																																																														
G1	VSS054	VSS055	AC24																																																																																																																																																																																																																																																																																																																																														
G23	VSS055	VSS056	AD2																																																																																																																																																																																																																																																																																																																																														
G26	VSS056	VSS057	AD5																																																																																																																																																																																																																																																																																																																																														
H3	VSS057	VSS058	AD8																																																																																																																																																																																																																																																																																																																																														
H6	VSS058	VSS059	AD11																																																																																																																																																																																																																																																																																																																																														
H21	VSS059	VSS060	AD13																																																																																																																																																																																																																																																																																																																																														
H24	VSS060	VSS061	AD16																																																																																																																																																																																																																																																																																																																																														
J4	VSS061	VSS062	AD19																																																																																																																																																																																																																																																																																																																																														
J5	VSS062	VSS063	AD22																																																																																																																																																																																																																																																																																																																																														
J22	VSS063	VSS064	AD25																																																																																																																																																																																																																																																																																																																																														
J25	VSS064	VSS065	AE1																																																																																																																																																																																																																																																																																																																																														
K1	VSS065	VSS066	AE4																																																																																																																																																																																																																																																																																																																																														
K4	VSS066	VSS067	AE8																																																																																																																																																																																																																																																																																																																																														
K23	VSS067	VSS068	AE11																																																																																																																																																																																																																																																																																																																																														
K26	VSS068	VSS069	AE14																																																																																																																																																																																																																																																																																																																																														
L3	VSS069	VSS070	AE16																																																																																																																																																																																																																																																																																																																																														
L6	VSS070	VSS071	AE19																																																																																																																																																																																																																																																																																																																																														
L21	VSS071	VSS072	AE23																																																																																																																																																																																																																																																																																																																																														
L24	VSS072	VSS073	AE26																																																																																																																																																																																																																																																																																																																																														
M2	VSS073	VSS074	AF																																																																																																																																																																																																																																																																																																																																														
M5	VSS074	VSS075	AF6																																																																																																																																																																																																																																																																																																																																														
M22	VSS075	VSS076	AF8																																																																																																																																																																																																																																																																																																																																														
M25	VSS076	VSS077	AF11																																																																																																																																																																																																																																																																																																																																														
N1	VSS077	VSS078	AF13																																																																																																																																																																																																																																																																																																																																														
N4	VSS078	VSS079	AF16																																																																																																																																																																																																																																																																																																																																														
N23	VSS079	VSS080	AF19																																																																																																																																																																																																																																																																																																																																														
N26	VSS080	VSS081	AF21																																																																																																																																																																																																																																																																																																																																														
P3	VSS081		AF25																																																																																																																																																																																																																																																																																																																																														
P6			AF25																																																																																																																																																																																																																																																																																																																																														
B																																																																																																																																																																																																																																																																																																																																																	
C																																																																																																																																																																																																																																																																																																																																																	
D																																																																																																																																																																																																																																																																																																																																																	
E																																																																																																																																																																																																																																																																																																																																																	
F																																																																																																																																																																																																																																																																																																																																																	
	1	2	3	4	5	6	7	8																																																																																																																																																																																																																																																																																																																																									

INVENTEC

TITLE
Potomac10G
MEROM-4

SIZE A3	CODE CS	DOC. NUMBER 6050A2171501	REV AX1
-------------------	-------------------	------------------------------------	-------------------

CHANGE by **HSEIH JERRY** 21-Dec-2007

SHEET 17 OF 63

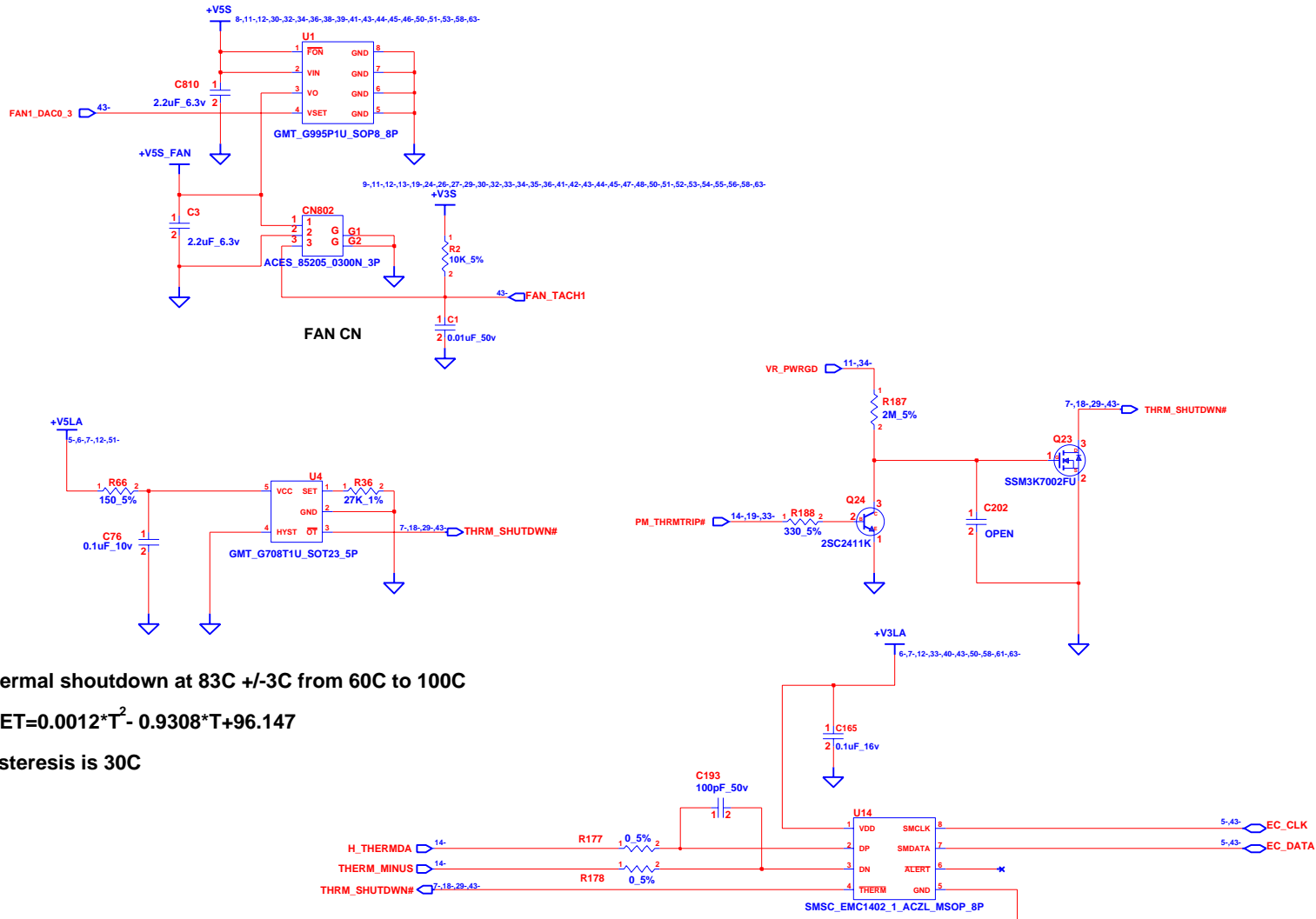

Thermal shutdown at 83C +/-3C from 60C to 100C
 $RSET=0.0012*T^2 - 0.9308*T+96.147$
 Hysteresis is 30C

Thermal Sensor For CPU
 LAYOUT NOTES: PUT THE THERMAL SENSOR CLOSE TO CPU

INVENTEC			
TITLE Potomac10G THERMAL&FAN CONTROLLER			
SIZE A3	CODE CS	DOC NUMBER 6050A2171501	REV AX1
CHANGE by HSEH JERRY		21-Dec-2007	
SHEET 18		OF 63	

CLOSE to NB

PEG_TXN15	20-	C883	1	2	0.1uF 10v	29-	PEG_C_TXN15
PEG_TXN14	20-	C867	1	2	0.1uF 10v	29-	PEG_C_TXN14
PEG_TXN13	20-	C881	1	2	0.1uF 10v	29-	PEG_C_TXN13
PEG_TXN12	20-	C865	1	2	0.1uF 10v	29-	PEG_C_TXN12
PEG_TXN11	20-	C879	1	2	0.1uF 10v	29-	PEG_C_TXN11
PEG_TXN10	20-	C863	1	2	0.1uF 10v	29-	PEG_C_TXN10
PEG_TXN9	20-	C877	1	2	0.1uF 10v	29-	PEG_C_TXN9
PEG_TXN8	20-	C861	1	2	0.1uF 10v	29-	PEG_C_TXN8
PEG_TXN7	20-	C875	1	2	0.1uF 10v	29-	PEG_C_TXN7
PEG_TXN6	20-	C859	1	2	0.1uF 10v	29-	PEG_C_TXN6
PEG_TXN5	20-	C873	1	2	0.1uF 10v	29-	PEG_C_TXN5
PEG_TXN4	20-	C857	1	2	0.1uF 10v	29-	PEG_C_TXN4
PEG_TXN3	20-	C871	1	2	0.1uF 10v	29-	PEG_C_TXN3
PEG_TXN2	20-	C855	1	2	0.1uF 10v	29-	PEG_C_TXN2
PEG_TXN1	20-	C869	1	2	0.1uF 10v	29-	PEG_C_TXN1
PEG_TXN0	20-	C853	1	2	0.1uF 10v	29-	PEG_C_TXN0
PEG_TXP15	20-	C882	1	2	0.1uF 10v	29-	PEG_C_TXP15
PEG_TXP14	20-	C866	1	2	0.1uF 10v	29-	PEG_C_TXP14
PEG_TXP13	20-	C880	1	2	0.1uF 10v	29-	PEG_C_TXP13
PEG_TXP12	20-	C864	1	2	0.1uF 10v	29-	PEG_C_TXP12
PEG_TXP11	20-	C878	1	2	0.1uF 10v	29-	PEG_C_TXP11
PEG_TXP10	20-	C862	1	2	0.1uF 10v	29-	PEG_C_TXP10
PEG_TXP9	20-	C876	1	2	0.1uF 10v	29-	PEG_C_TXP9
PEG_TXP8	20-	C860	1	2	0.1uF 10v	29-	PEG_C_TXP8
PEG_TXP7	20-	C874	1	2	0.1uF 10v	29-	PEG_C_TXP7
PEG_TXP6	20-	C858	1	2	0.1uF 10v	29-	PEG_C_TXP6
PEG_TXP5	20-	C872	1	2	0.1uF 10v	29-	PEG_C_TXP5
PEG_TXP4	20-	C856	1	2	0.1uF 10v	29-	PEG_C_TXP4
PEG_TXP3	20-	C870	1	2	0.1uF 10v	29-	PEG_C_TXP3
PEG_TXP2	20-	C854	1	2	0.1uF 10v	29-	PEG_C_TXP2
PEG_TXP1	20-	C868	1	2	0.1uF 10v	29-	PEG_C_TXP1
PEG_TXP0	20-	C852	1	2	0.1uF 10v	29-	PEG_C_TXP0

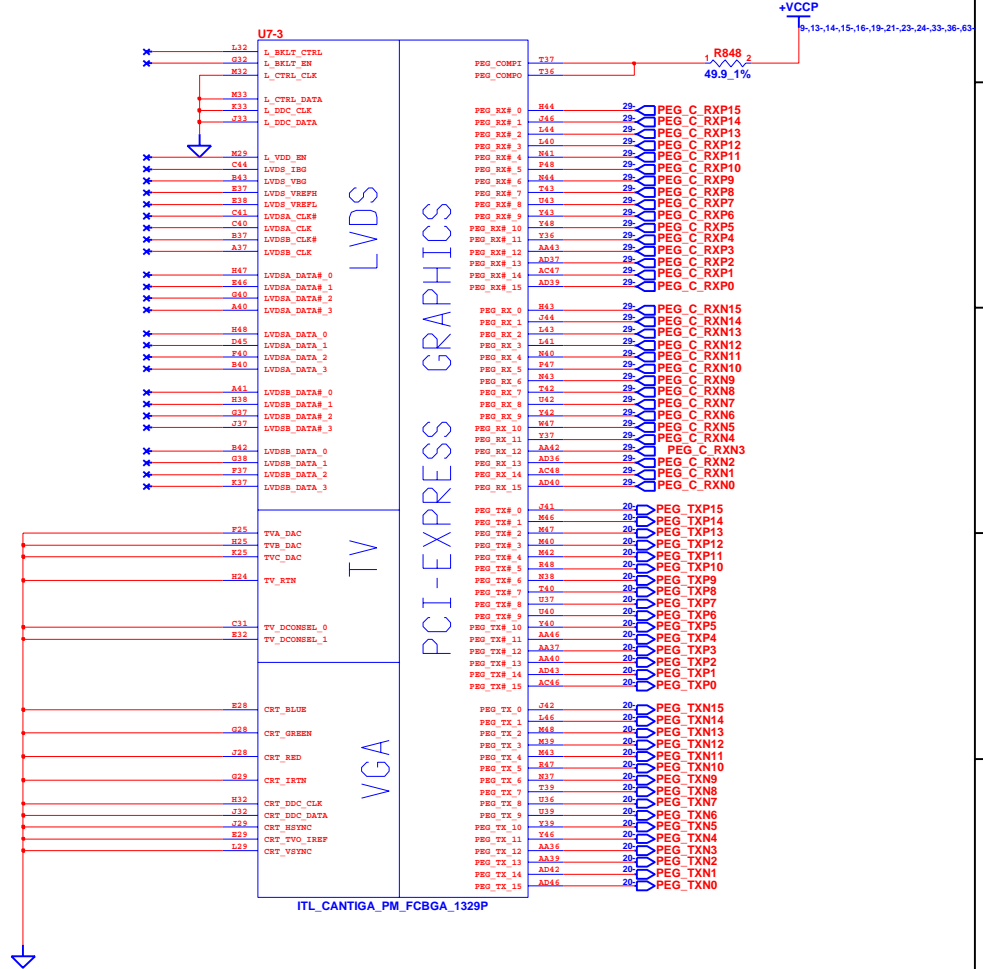

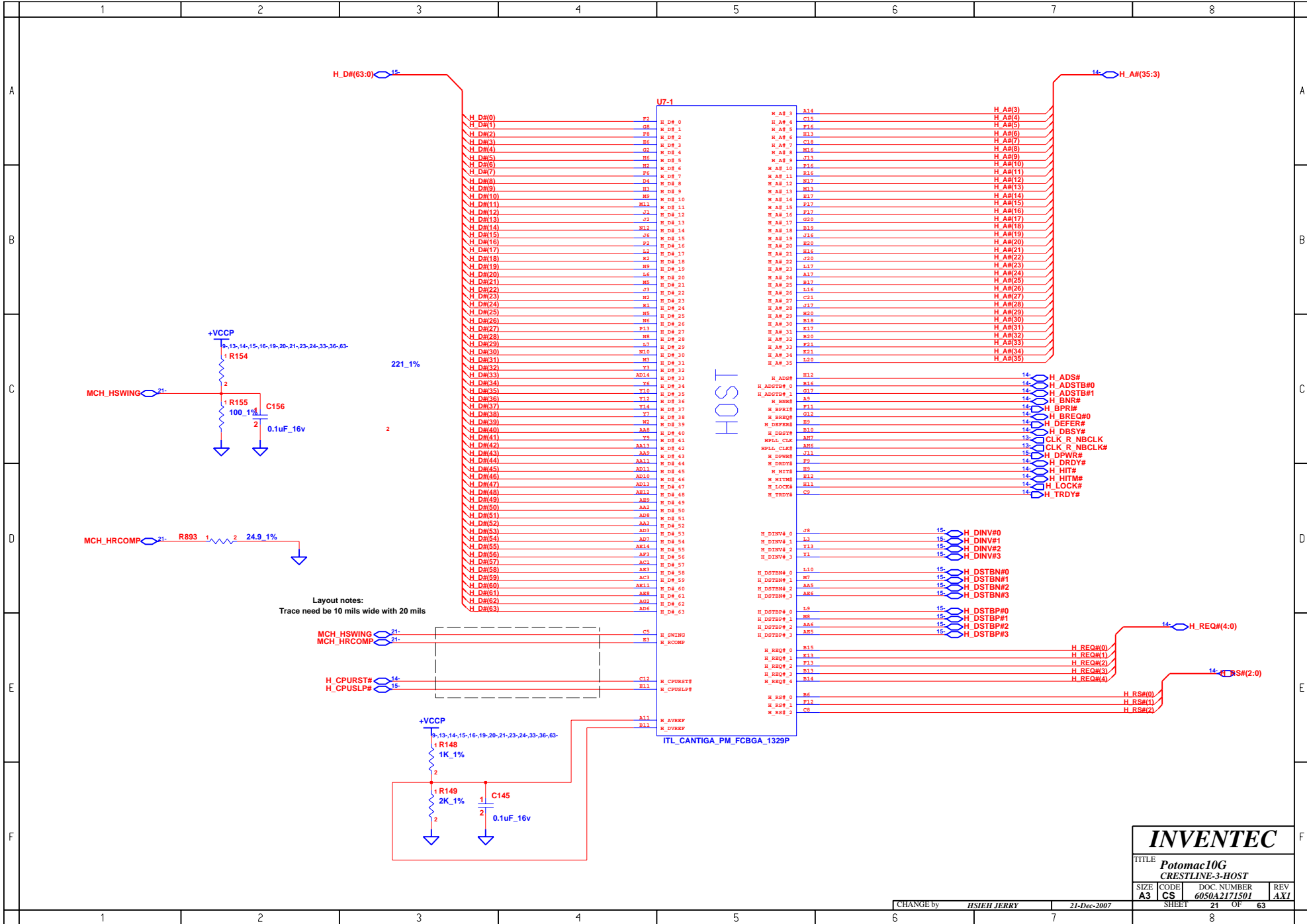

Layout notes:
Trace need be 10 mils wide with 20 mils

INVENTEC

TITLE
Potomac10G
CRESTLINE-3-HOST

SIZE A3	CODE CS	DOC. NUMBER 6050A2171501	REV AX1
CHANGE by HSEH JERRY		21-Dec-2007	
SHEET 21		OF 63	

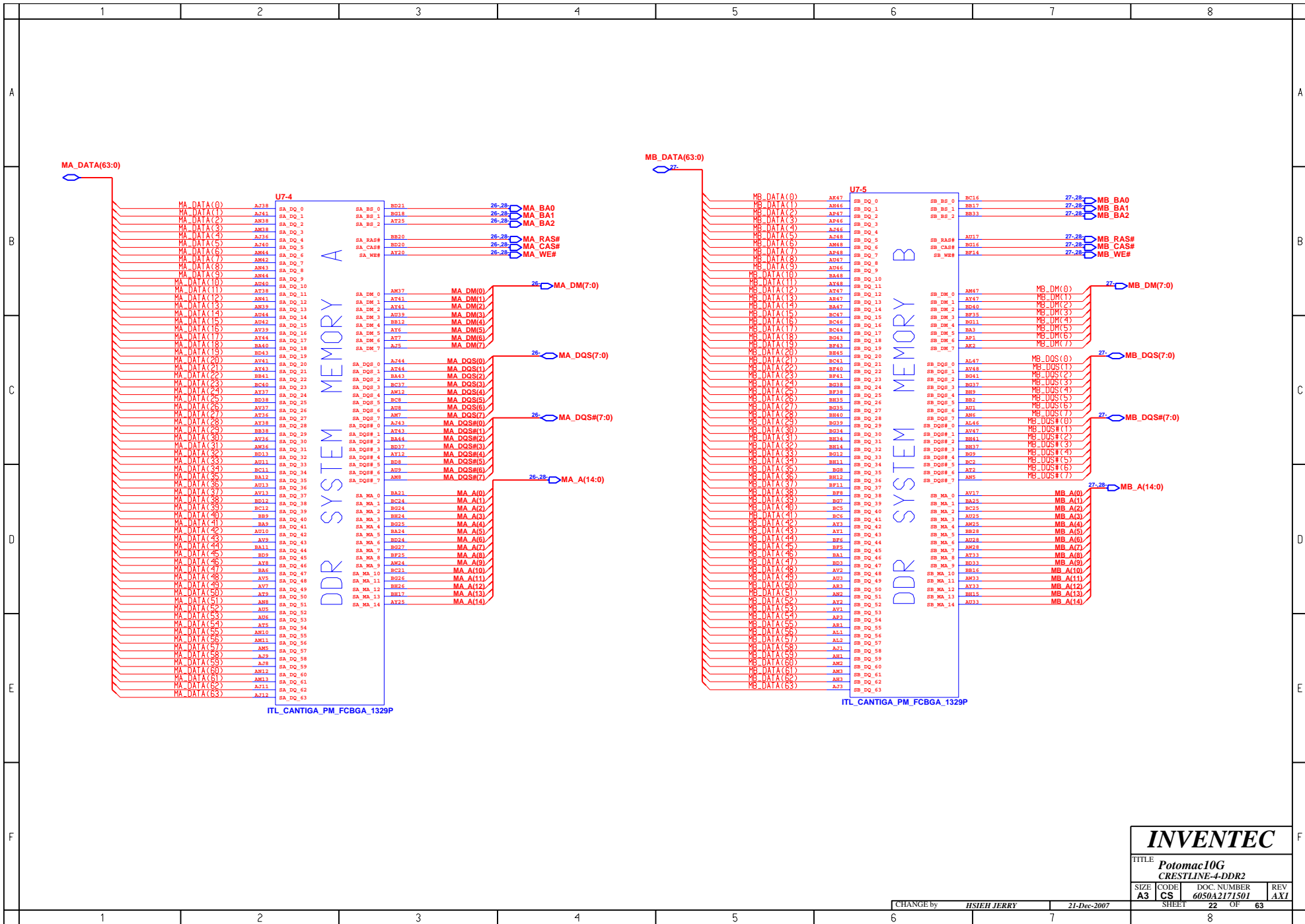

INVENTEC			
TITLE Potomac10G CRESTLINE-4-DDR2			
SIZE A3	CODE CS	DOC. NUMBER 6050A2171501	REV AX1
CHANGE by HSEIH JERRY		21-Dec-2007	
SHEET 22		OF 63	

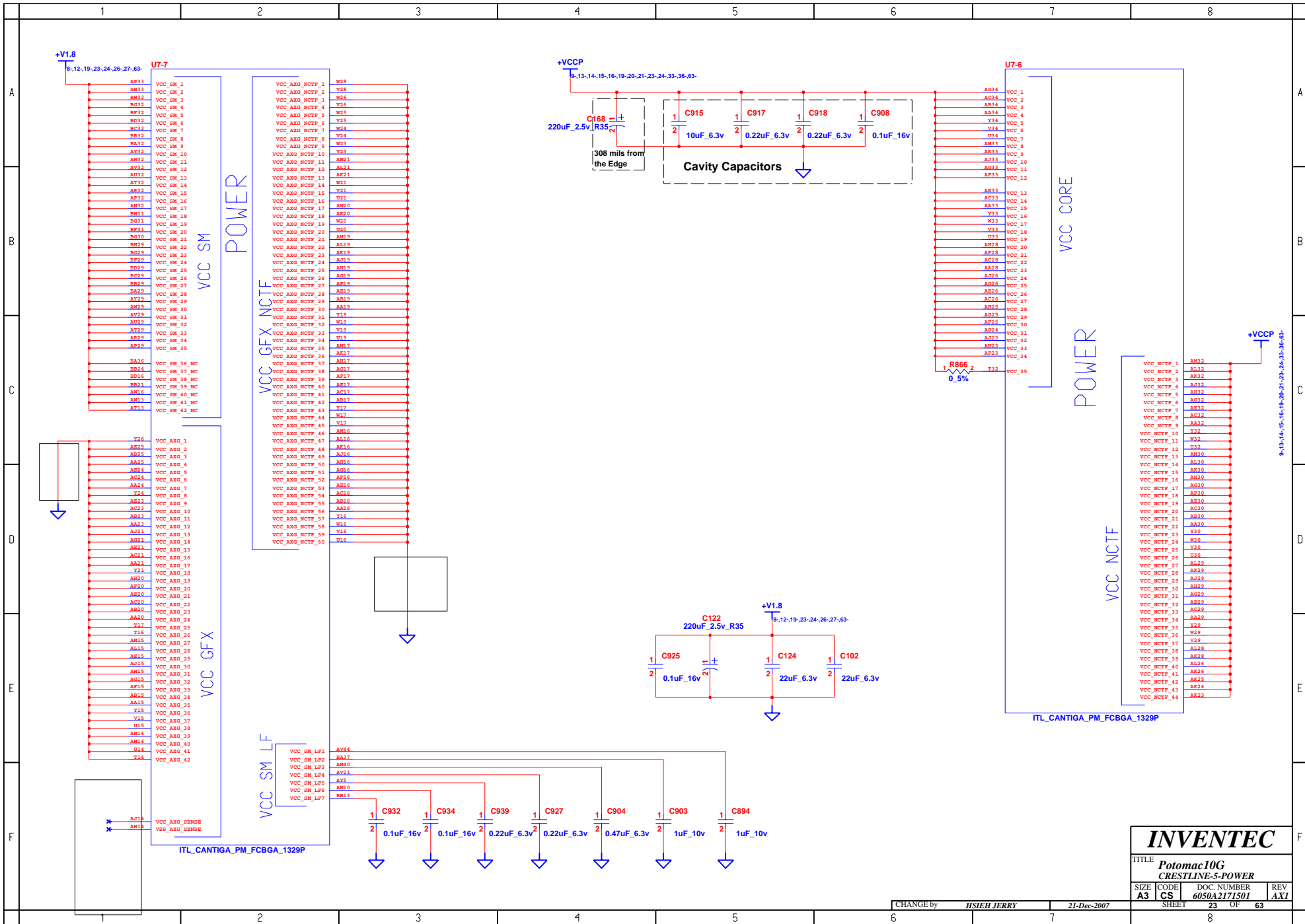

INVENTEC			
TITLE Potomac10G CRESTLINE-5-POWER			
SIZE A3	CODE CS	DOC. NUMBER 6050A2171501	REV AX1
CHANGE by HSEIH JERRY		21-Dec-2007	
SHEET 23		OF 63	

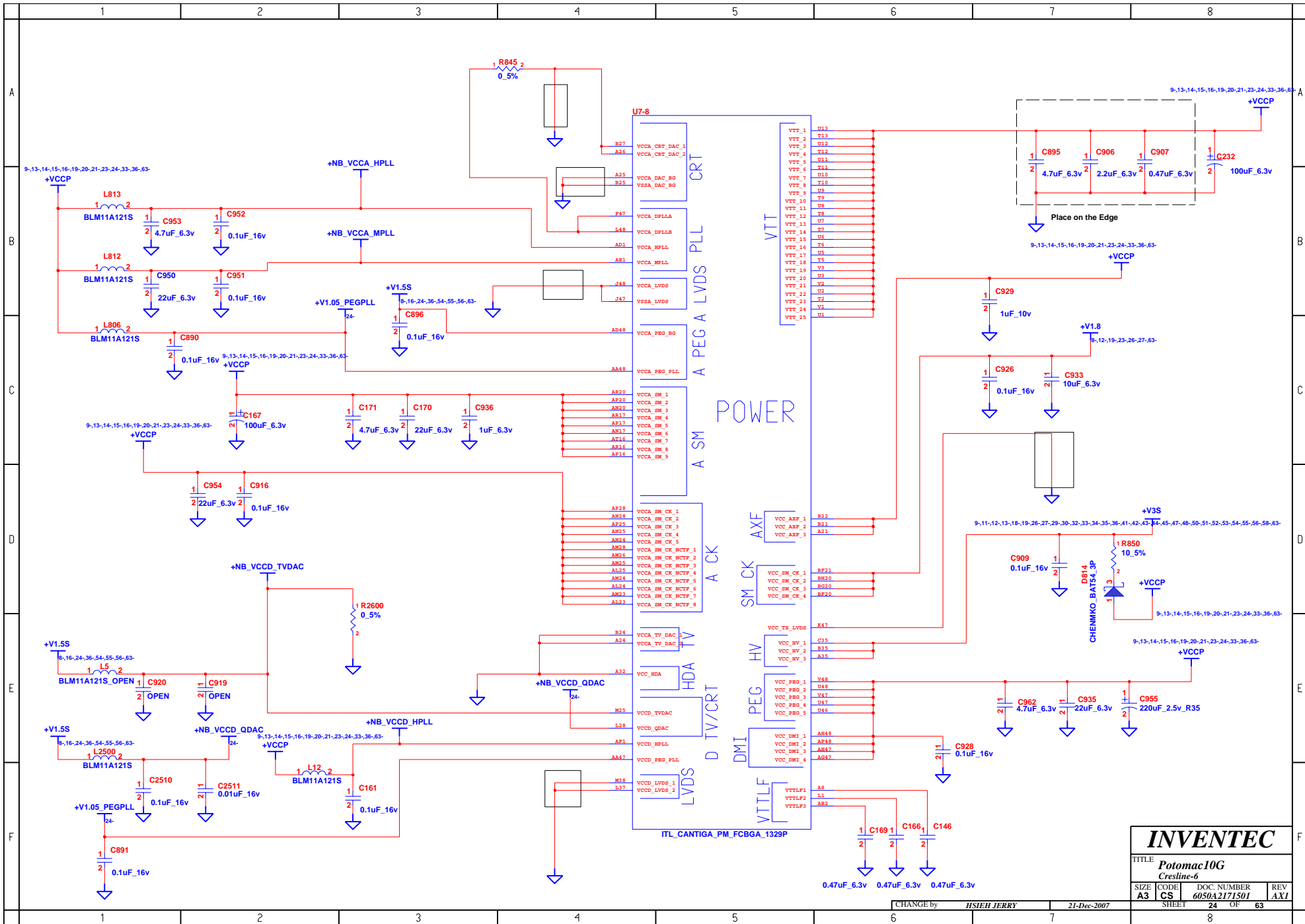

INVENTEC			
TITLE Potomac10G Cresline-6			
SIZE A3	CODE CS	DOC. NUMBER 6050A217501	REV AX1
CHANGE by HSEH JERRY		21-Dec-2007	
SHEET 24		OF 63	

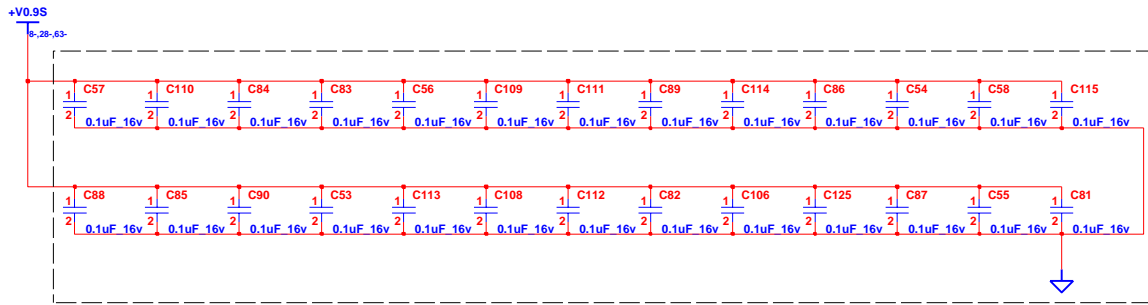

LAYOUT NOTES : PLACE ONE CAP CLOSE TO EVERY 2 PULL UP RESISTOR TERMINATED TO +V0.9S

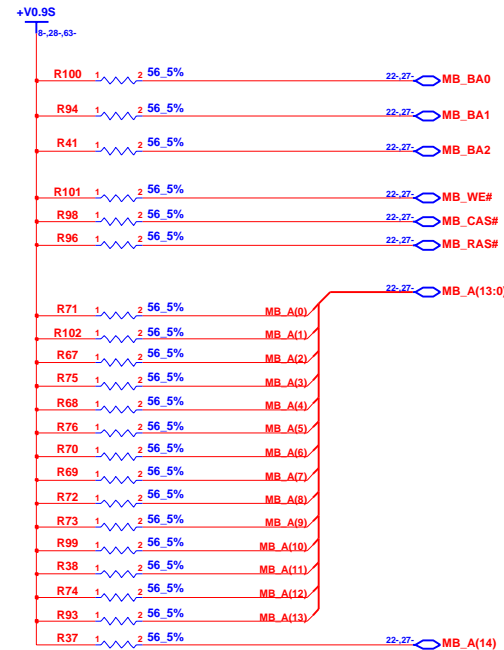
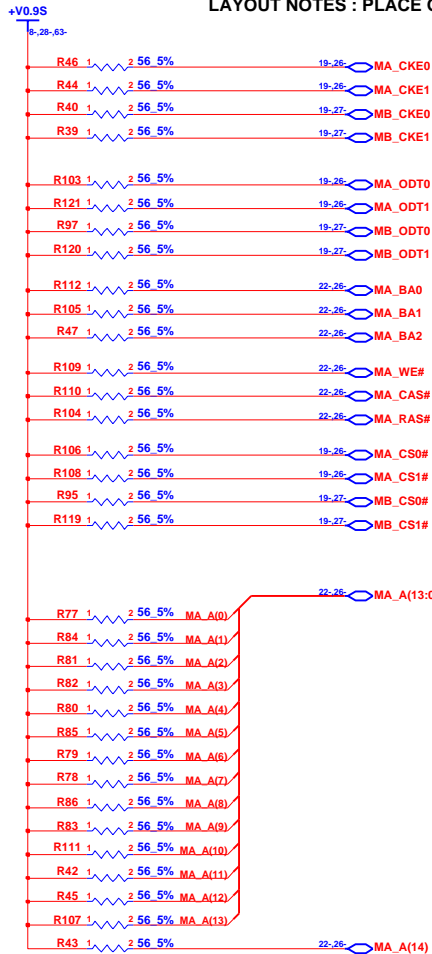

INVENTEC			
TITLE Potomac10G DDR2-DAMPING			
SIZE A3	CODE CS	DOC. NUMBER 6050A2171501	REV AX1
CHANGE by HSIEH JERRY		27-Sep-2003	
SHEET 28		OF 63	

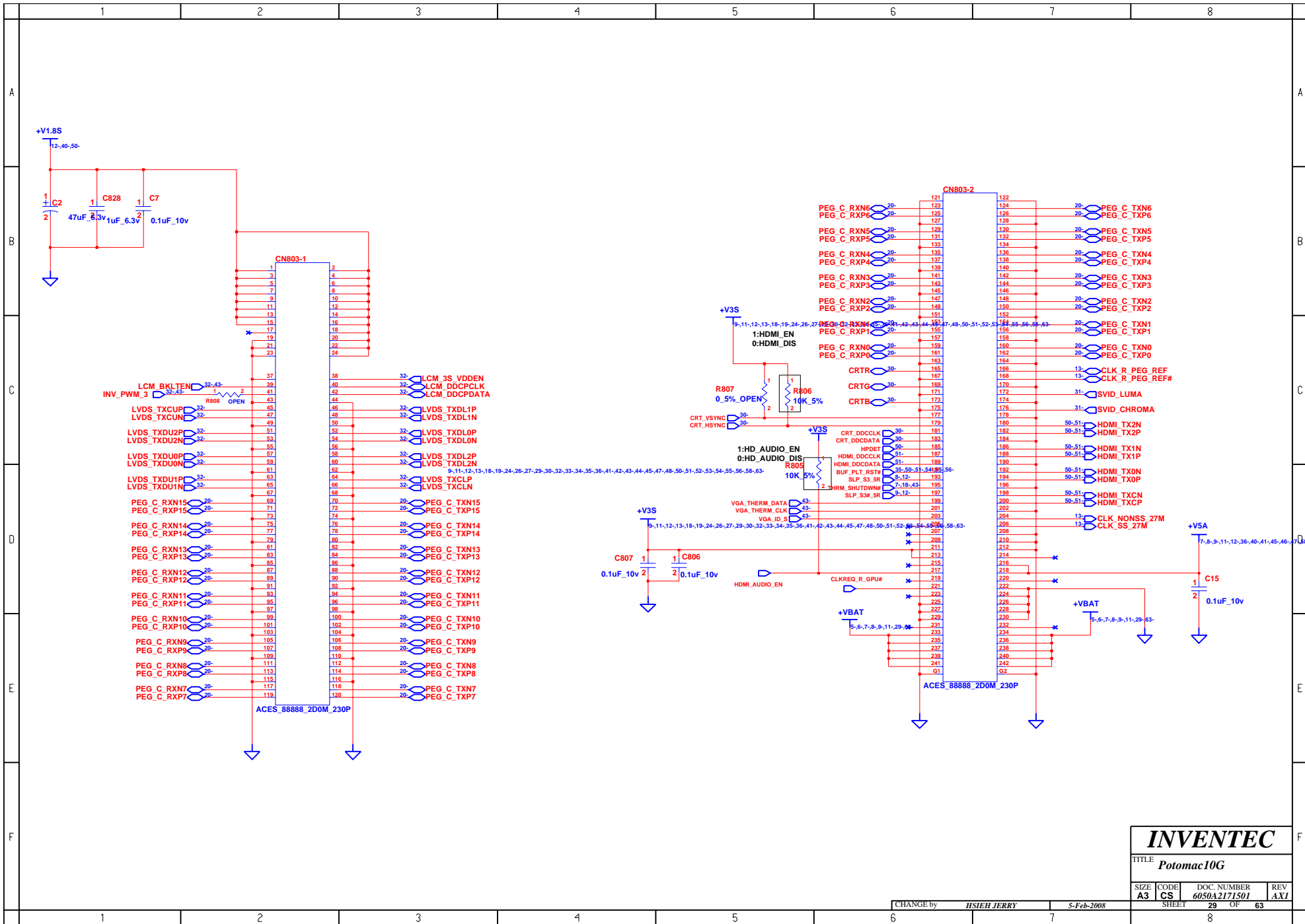

INVENTEC			
TITLE Potomac10G			
SIZE A3	CODE CS	DOC. NUMBER 6050A2171501	REV AX1
CHANGE by HSEH JERRY		5-Feb-2008	
SHEET 29		OF 63	

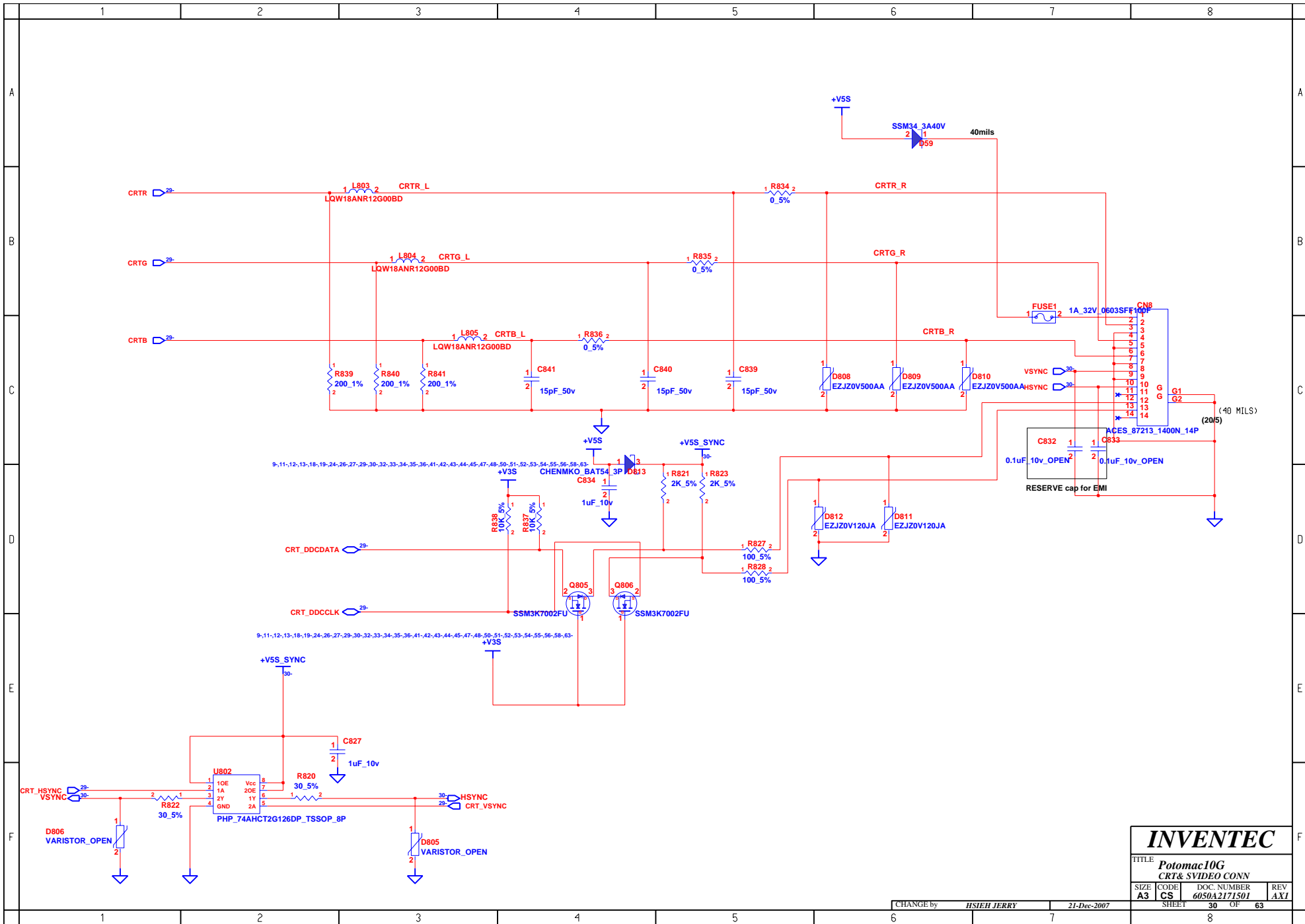

INVENTEC			
TITLE Potomac10G CRT & SVIDEO CONN			
SIZE A3	CODE CS	DOC. NUMBER 6050A2171501	REV AX1
CHANGE by HSEIH JERRY		21-Dec-2007	
SHEET 30		OF 63	

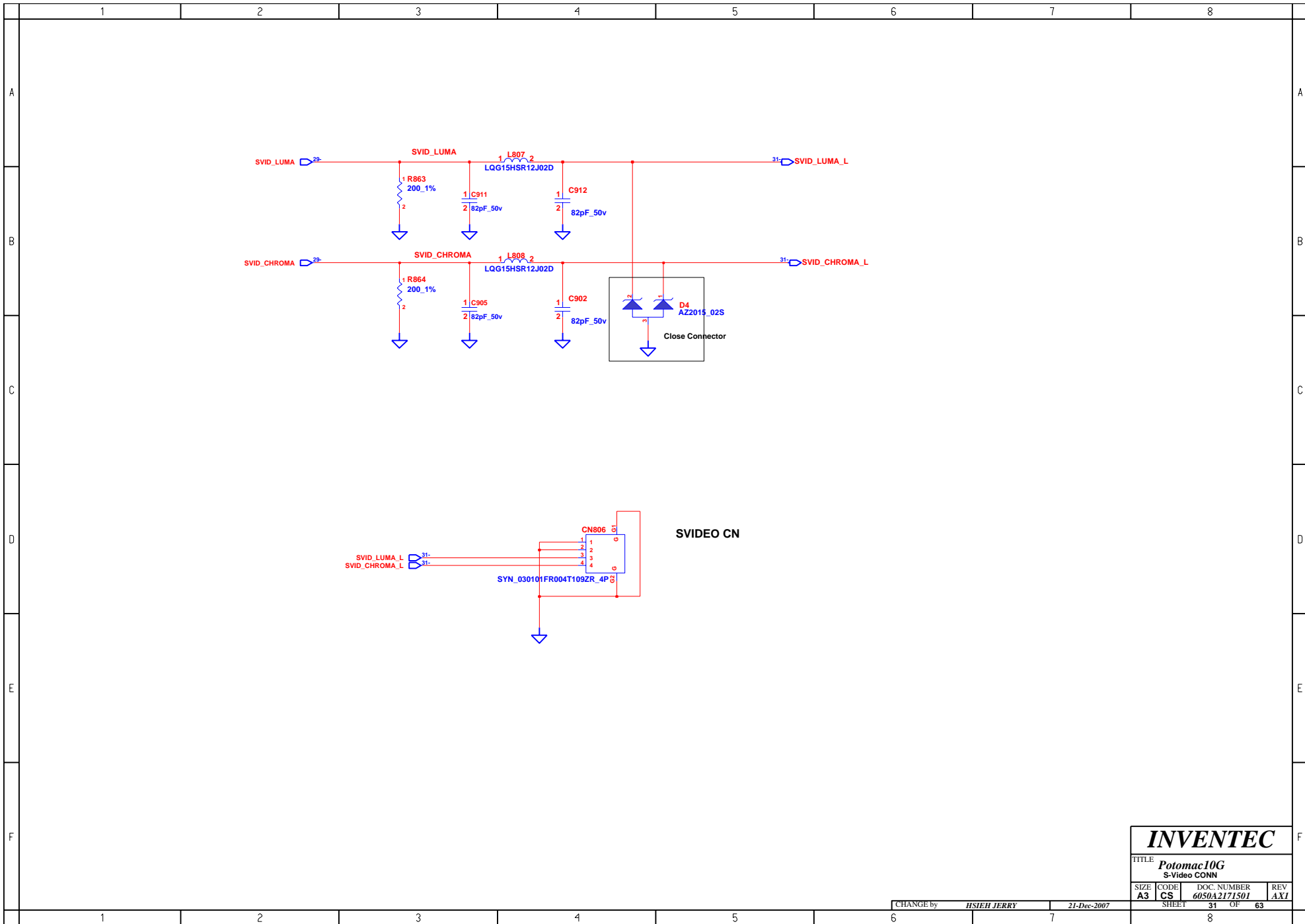

INVENTEC

TITLE **Potomac10G**
S-Video CONN

SIZE A3	CODE CS	DOC. NUMBER 6050A2171501	REV AXI
-------------------	-------------------	------------------------------------	-------------------

CHANGE by **HSEH JERRY** 21-Dec-2007

SHEET 31 OF 63

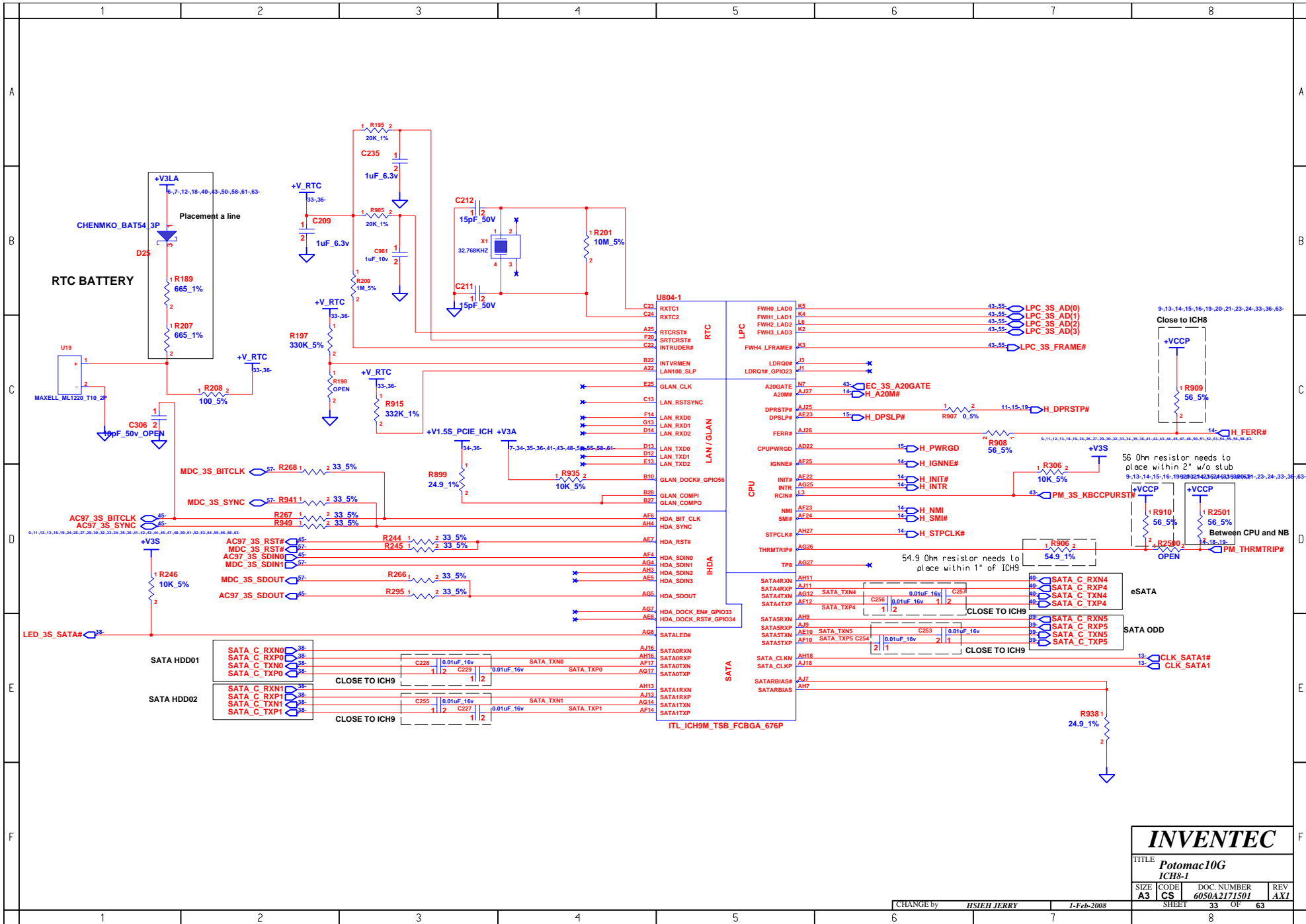

INVENTEC

TITLE
Potomac10G
IC8S-1

SIZE	CODE	DOC. NUMBER	REV
A3	CS	6050A2171501	AX1

hexainf@hotmail.com
 GRATIS - FOR FREE

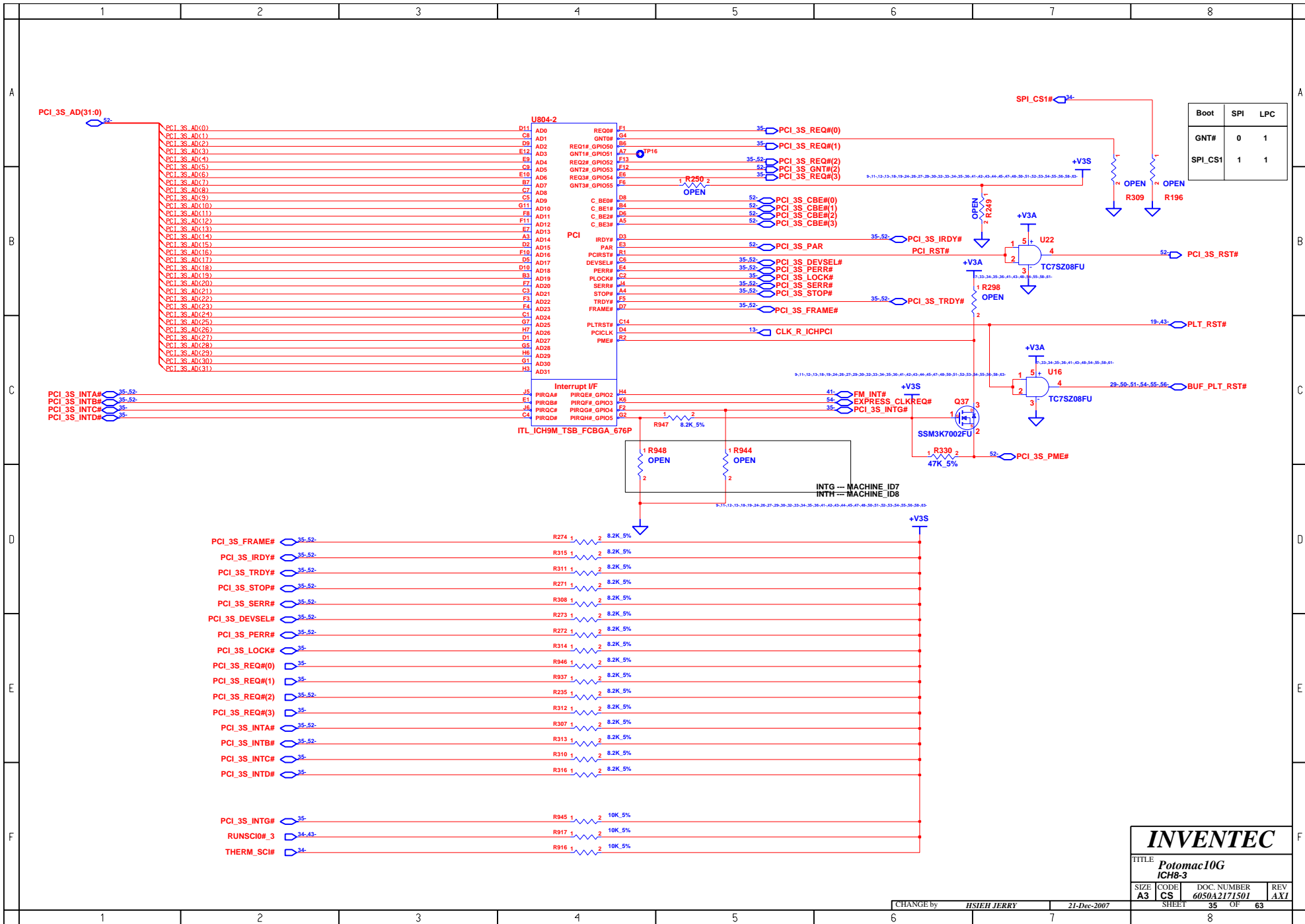

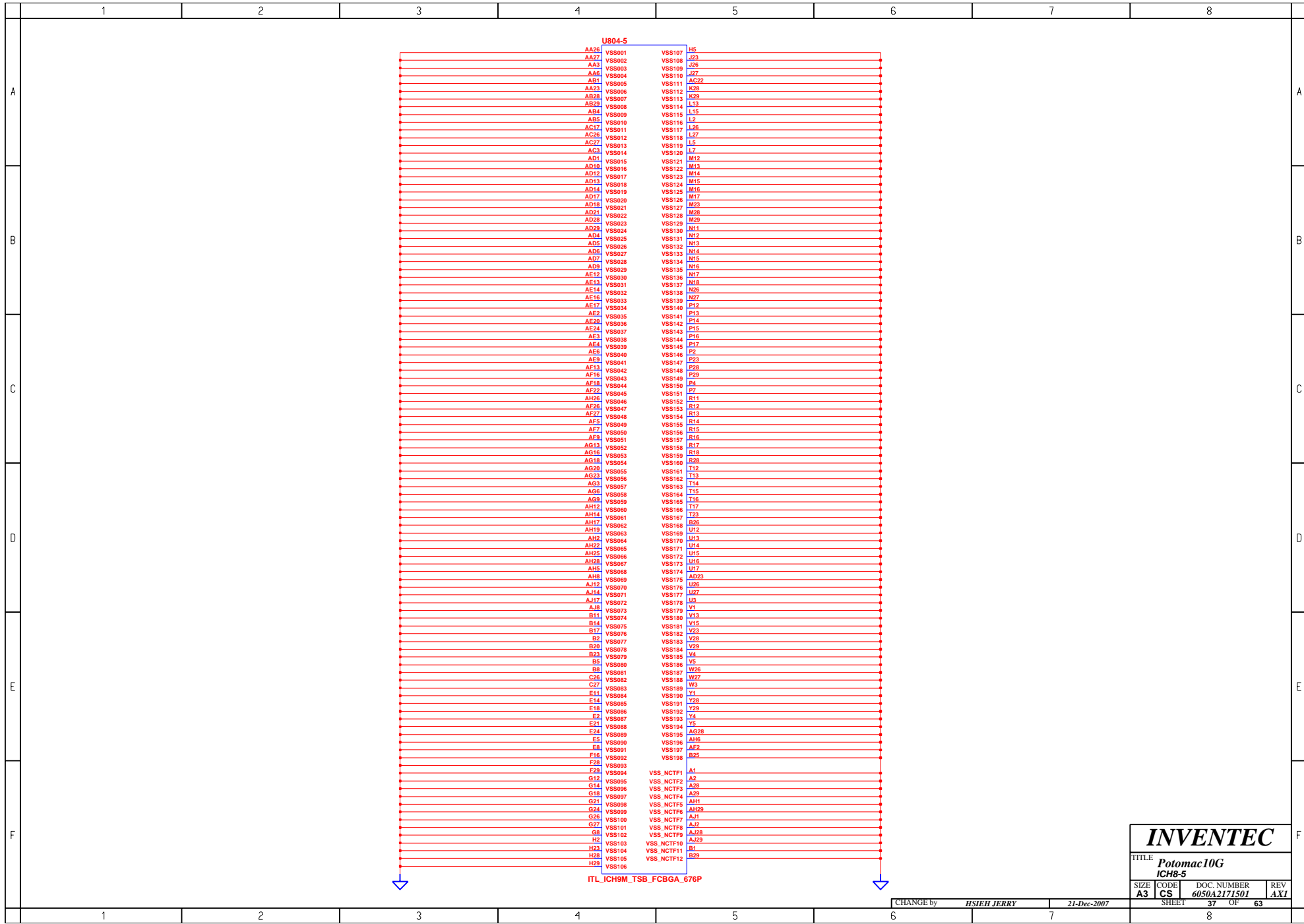

INVENTEC			
TITLE Potomac10G ICH8-5			
SIZE A3	CODE CS	DOC. NUMBER 6050A2171501	REV AX1
CHANGE by HSEH JERRY		21-Dec-2007	
SHEET 37		OF 63	

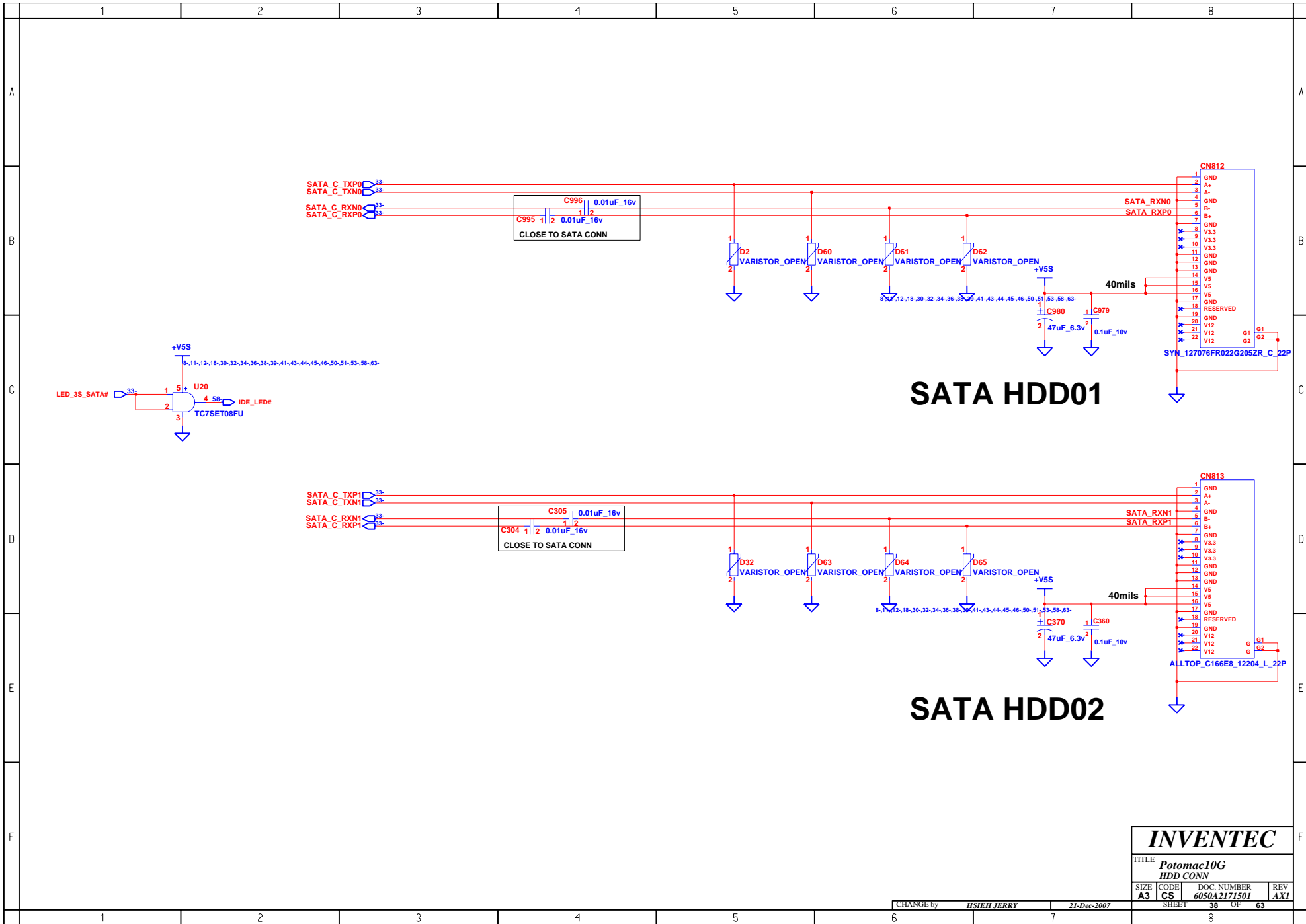

SATA HDD01

SATA HDD02

INVENTEC			
TITLE Potomac10G HDD CONN			
SIZE A3	CODE CS	DOC. NUMBER 6050A2171501	REV AX1
CHANGE by HSEIH JERRY		21-Dec-2007	
SHEET 38		OF 63	

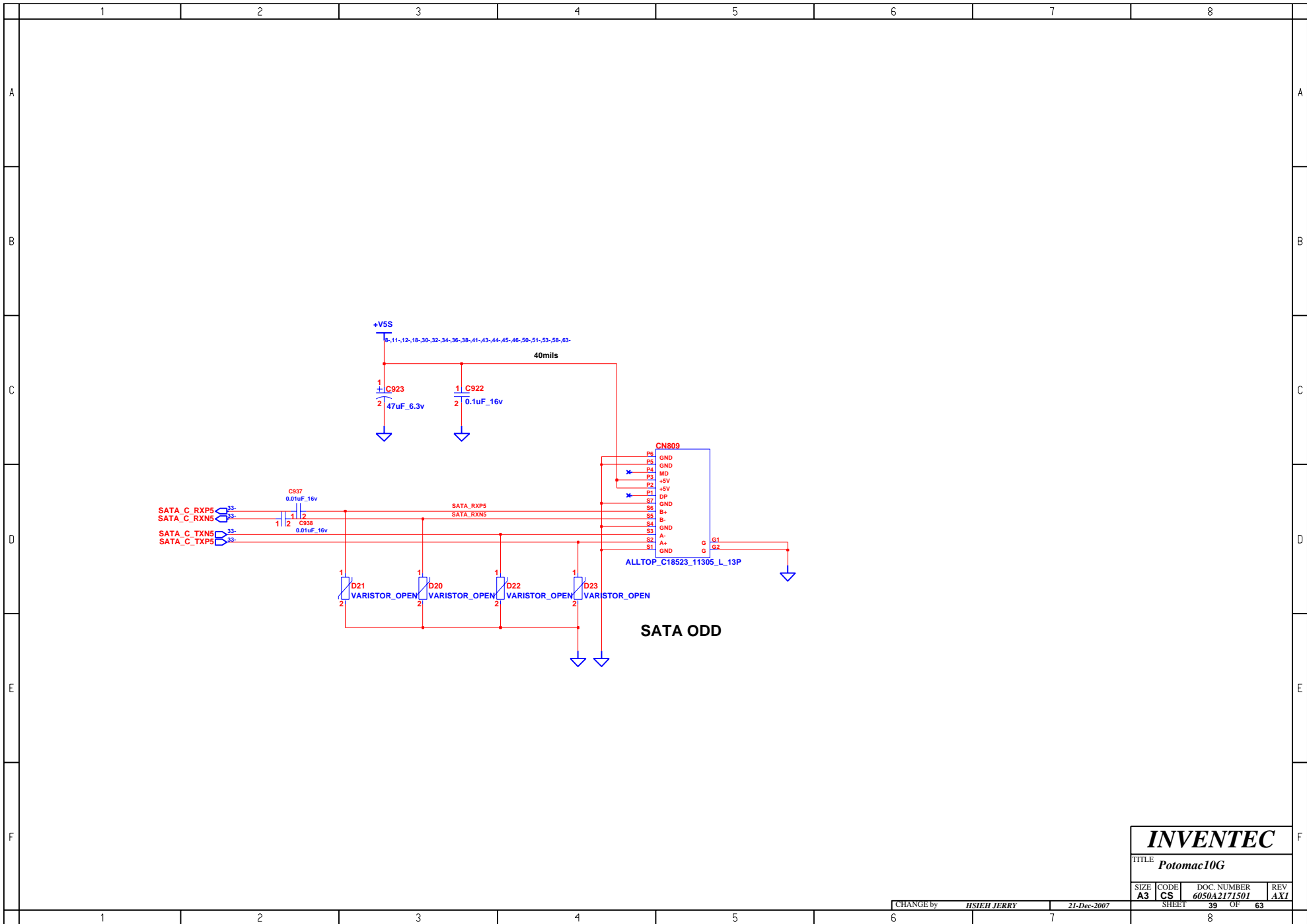

INVENTEC

TITLE
Potomac10G

SIZE A3	CODE CS	DOC. NUMBER 6050A2171501	REV AX1
-------------------	-------------------	------------------------------------	-------------------

CHANGE by **HSEIH JERRY** 21-Dec-2007

SHEET 39 OF 63

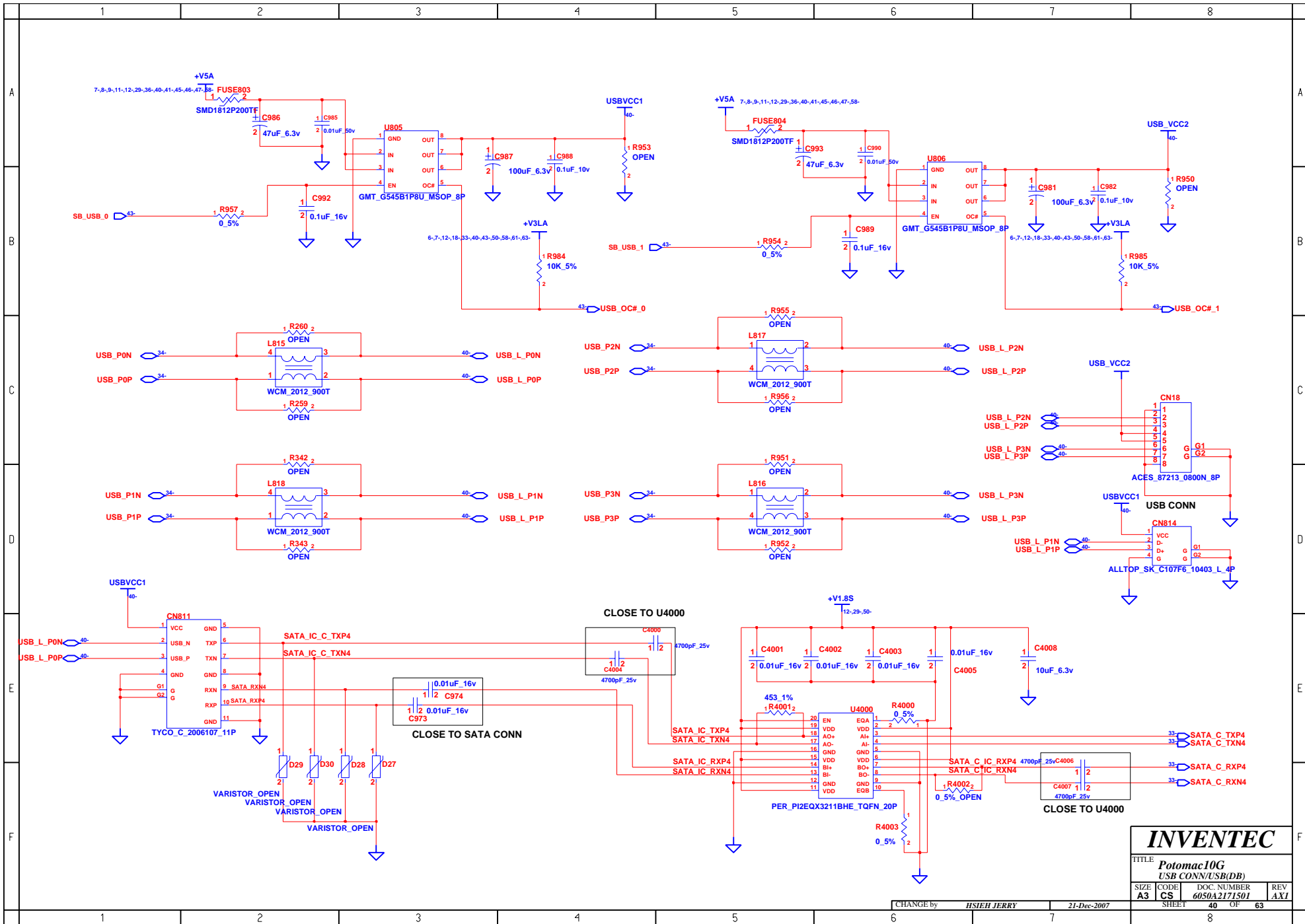

INVENTEC			
TITLE Potomac10G USB CONN/USB(DB)			
SIZE A3	CODE CS	DOC. NUMBER 6050A2171501	REV AX1
CHANGE by HSEH JERRY		21-Dec-2007	
SHEET 40		OF 63	

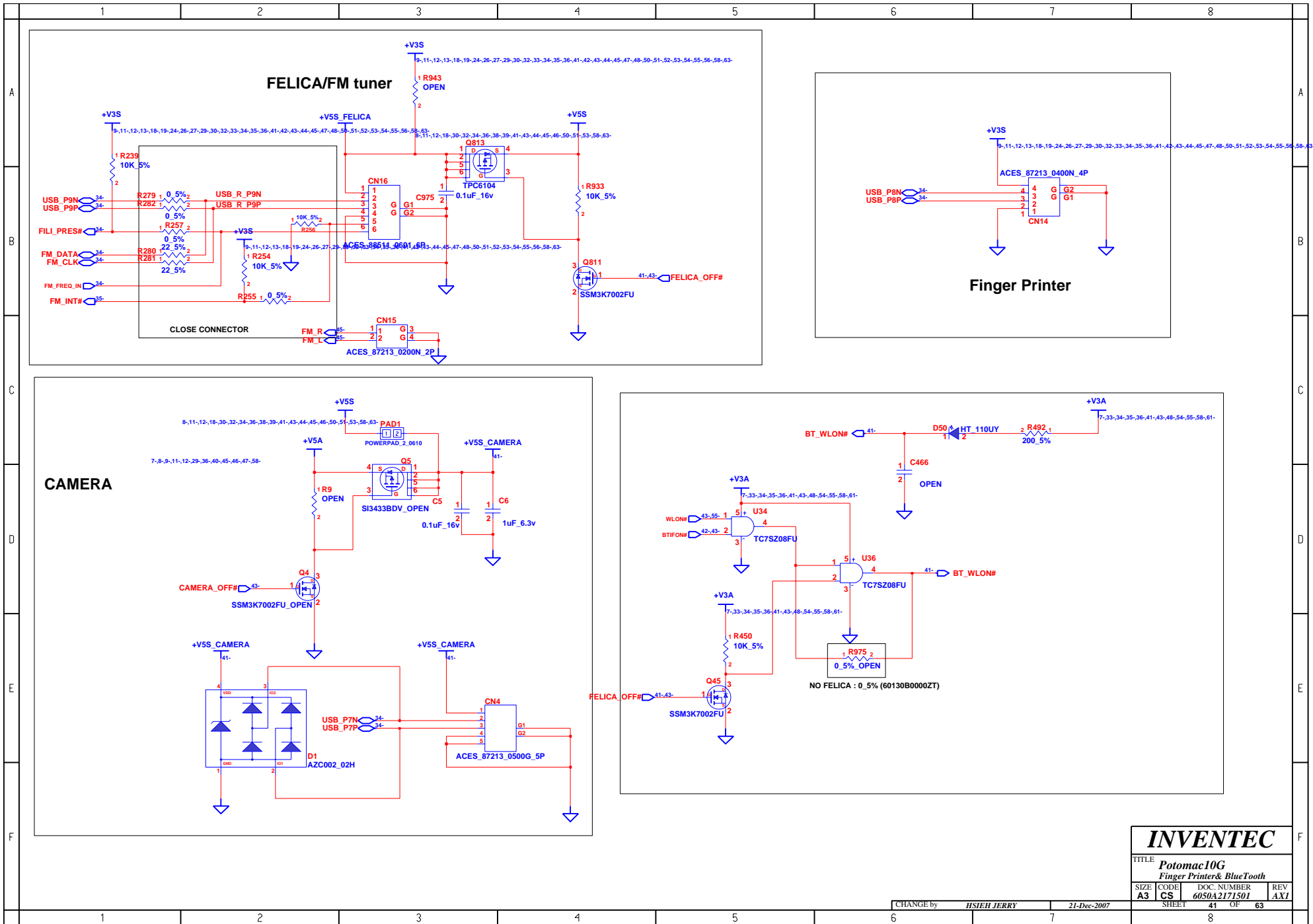

INVENTEC			
TITLE Potomac10G			
Finger Printer& Bluetooth			
SIZE A3	CODE CS	DOC. NUMBER 6050A2171501	REV AX1
CHANGE by HSEIH JERRY		21-Dec-2007	SHEET 41 OF 63

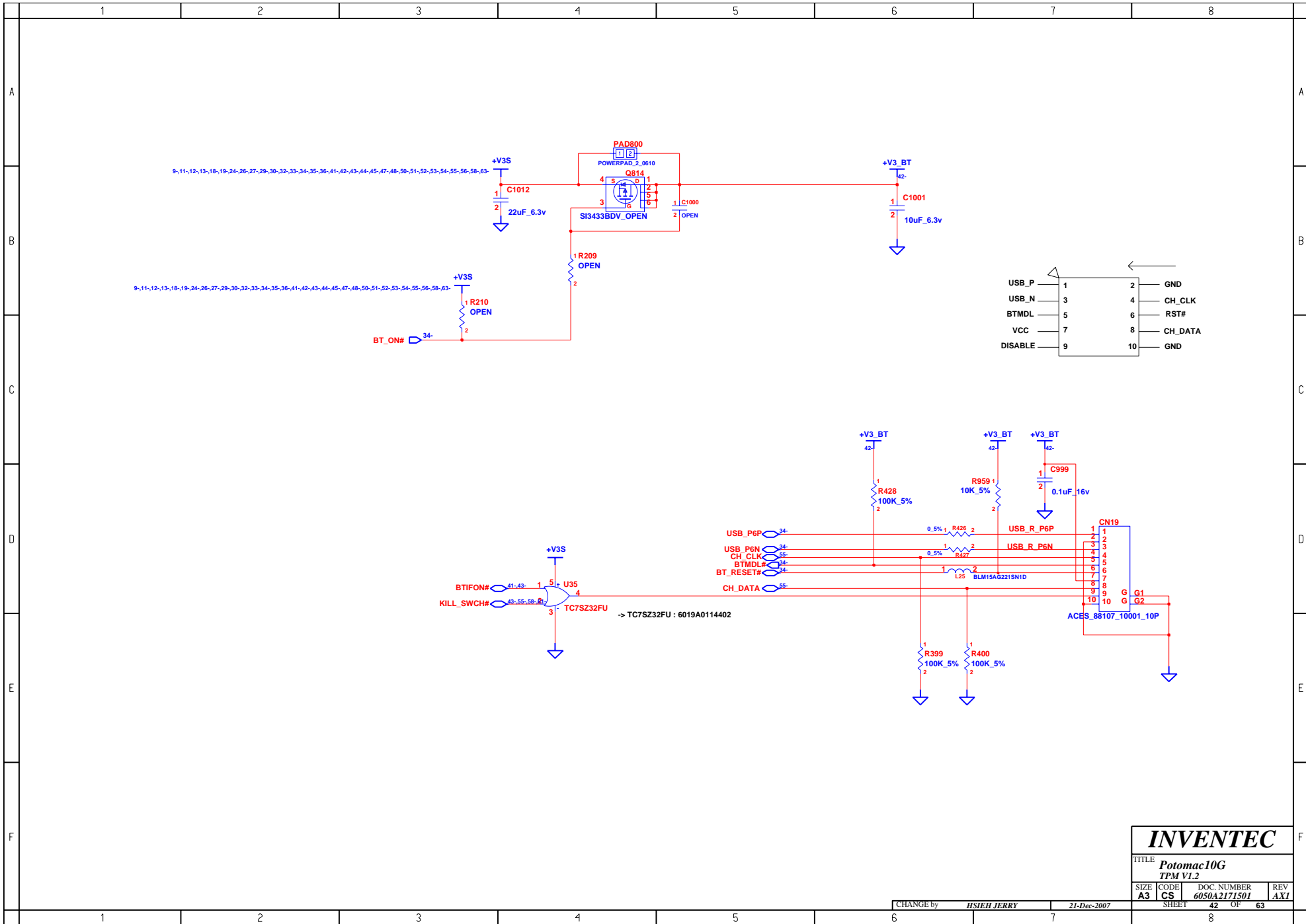

INVENTEC

TITLE
Potomac10G
 TPM V1.2

SIZE	CODE	DOC. NUMBER	REV
A3	CS	6050A2171501	AX1

CHANGE by **HSEIH JERRY** 21-Dec-2007

SHEET 42 OF 63

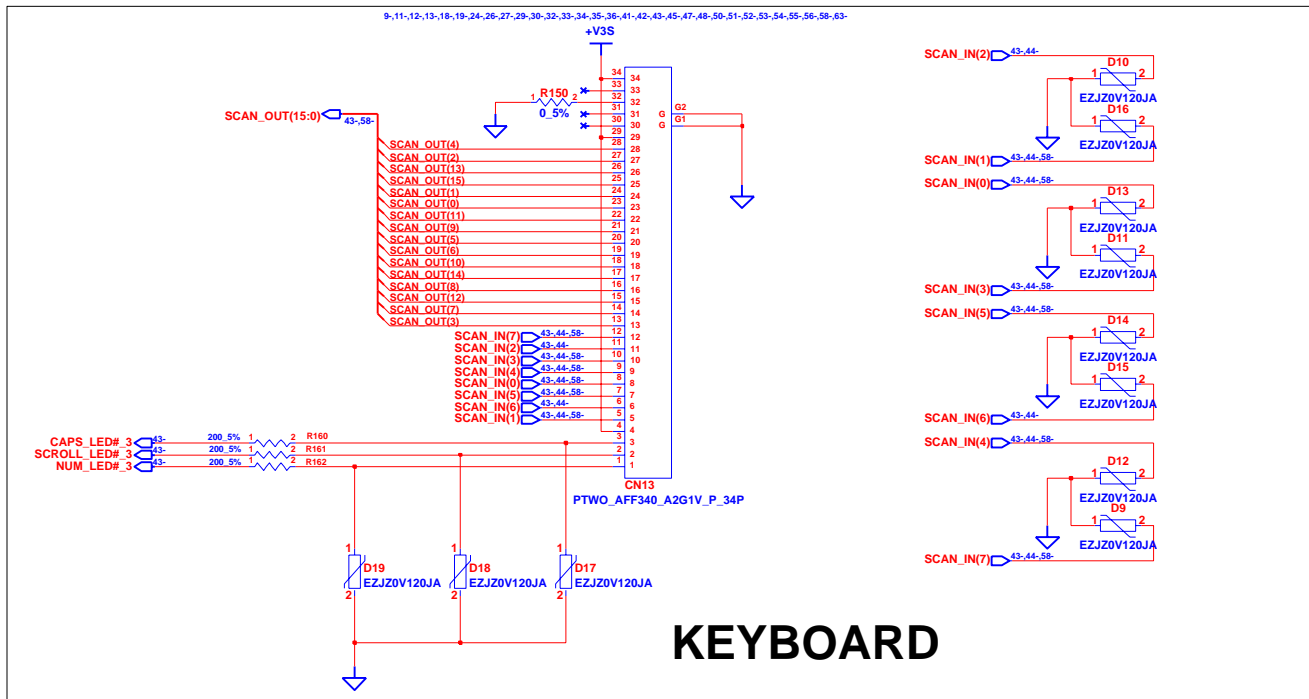

KEYBOARD

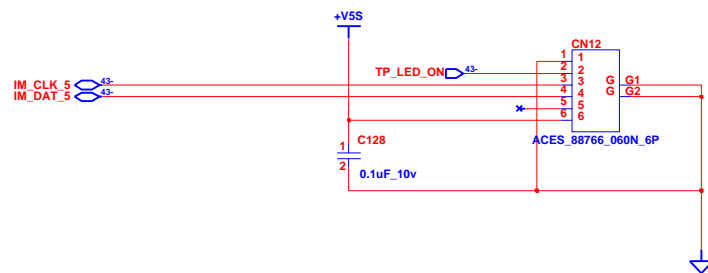

INVENTEC

TITLE			
Potomac10G INT.KBC/POINT DEVICES			
SIZE	CODE	DOC. NUMBER	REV
A3	CS	6050A2171501	AXI
CHANGE by		SHEET	OF
HSEH JERRY		44	63

21-Dec-2007

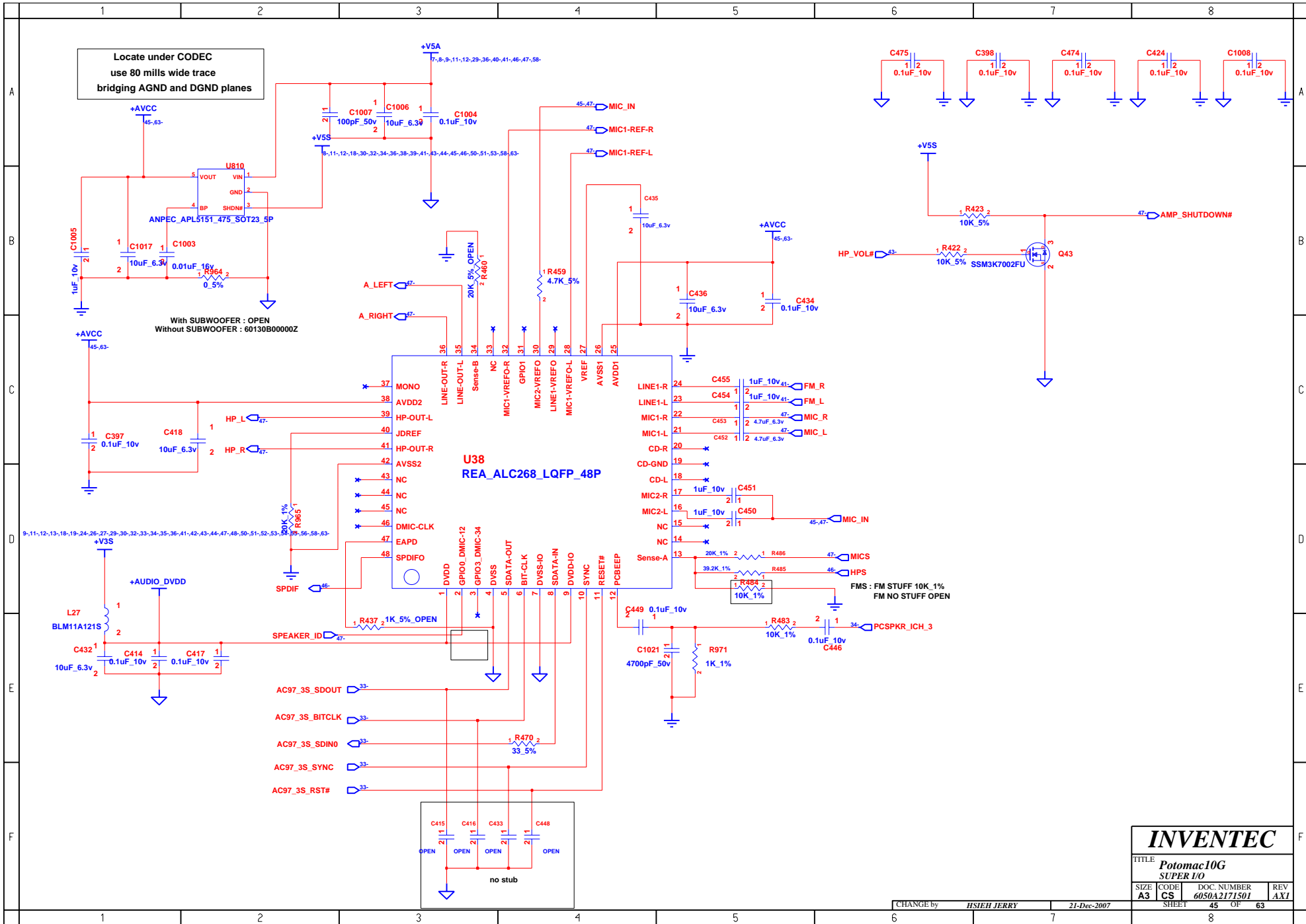

INVENTEC			
TITLE Potomac10G SUPER I/O			
SIZE A3	CODE CS	DOC. NUMBER 6050A2171501	REV AX1
CHANGE by HSEH JERRY		21-Dec-2007	
SHEET 45		OF 63	

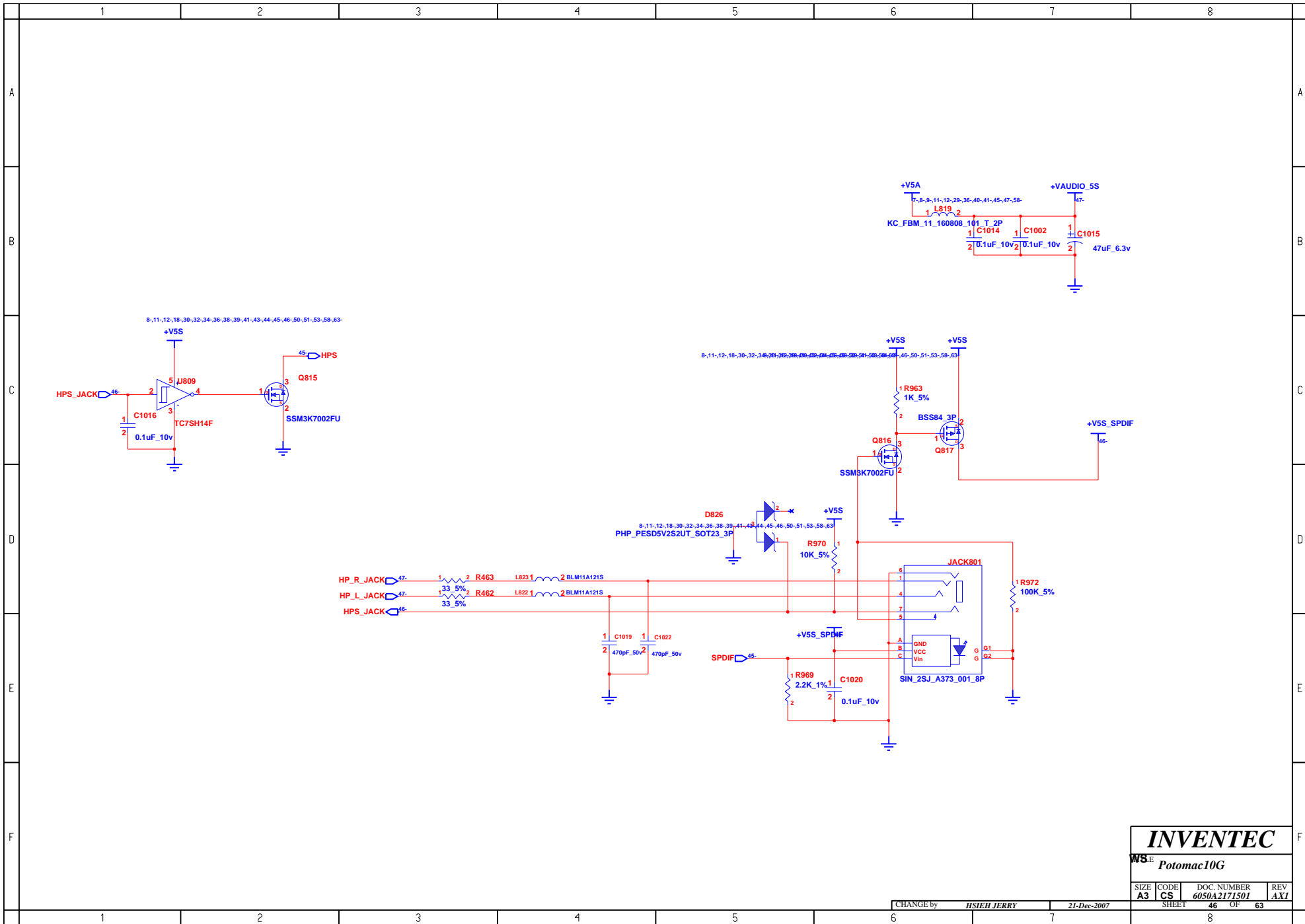

INVENTEC

WS^E Potomac10G

SIZE A3	CODE CS	DOC. NUMBER 6050A2171501	REV AX1
------------	------------	-----------------------------	------------

CHANGE by HSEIH JERRY 21-Dec-2007

SHEET 46 OF 63

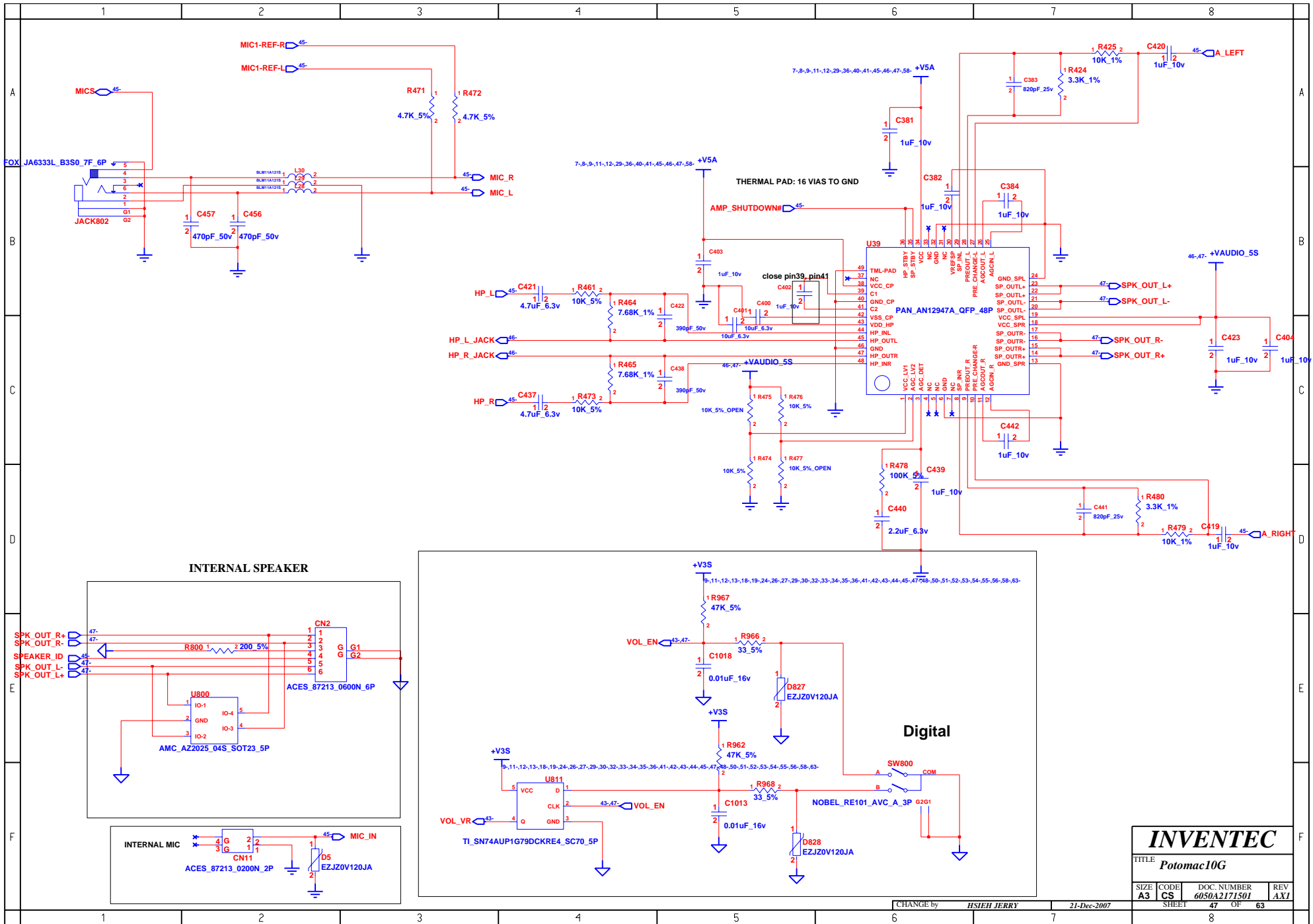

INTERNAL SPEAKER

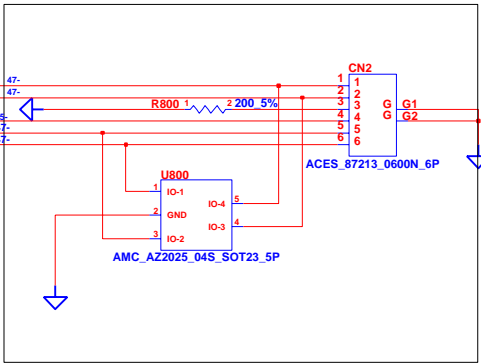

INTERNAL MIC

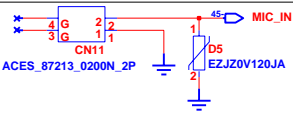

Digital

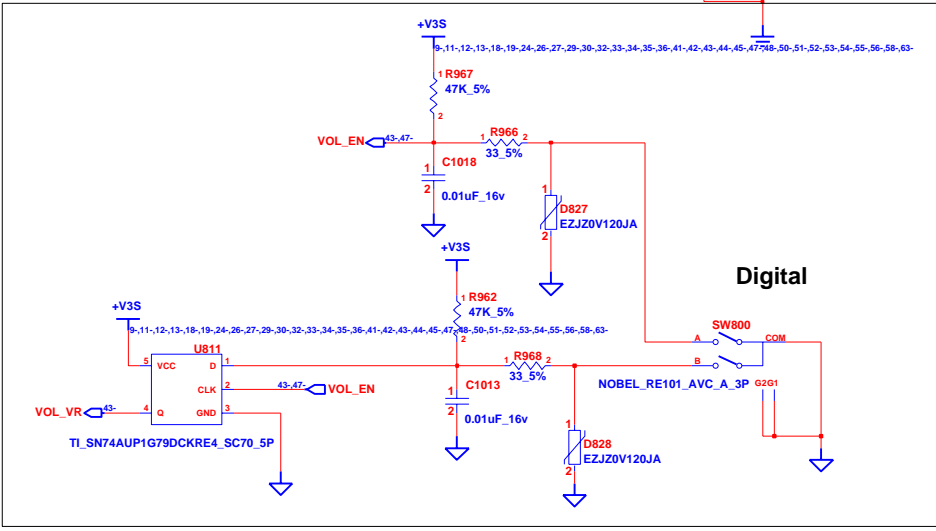

INVENTEC

TITLE **Potomac10G**

SIZE	CODE	DOC. NUMBER	REV
A3	CS	6050A2171501	AX1

CHANGE by **HSHH JERRY** 21-Dec-2007

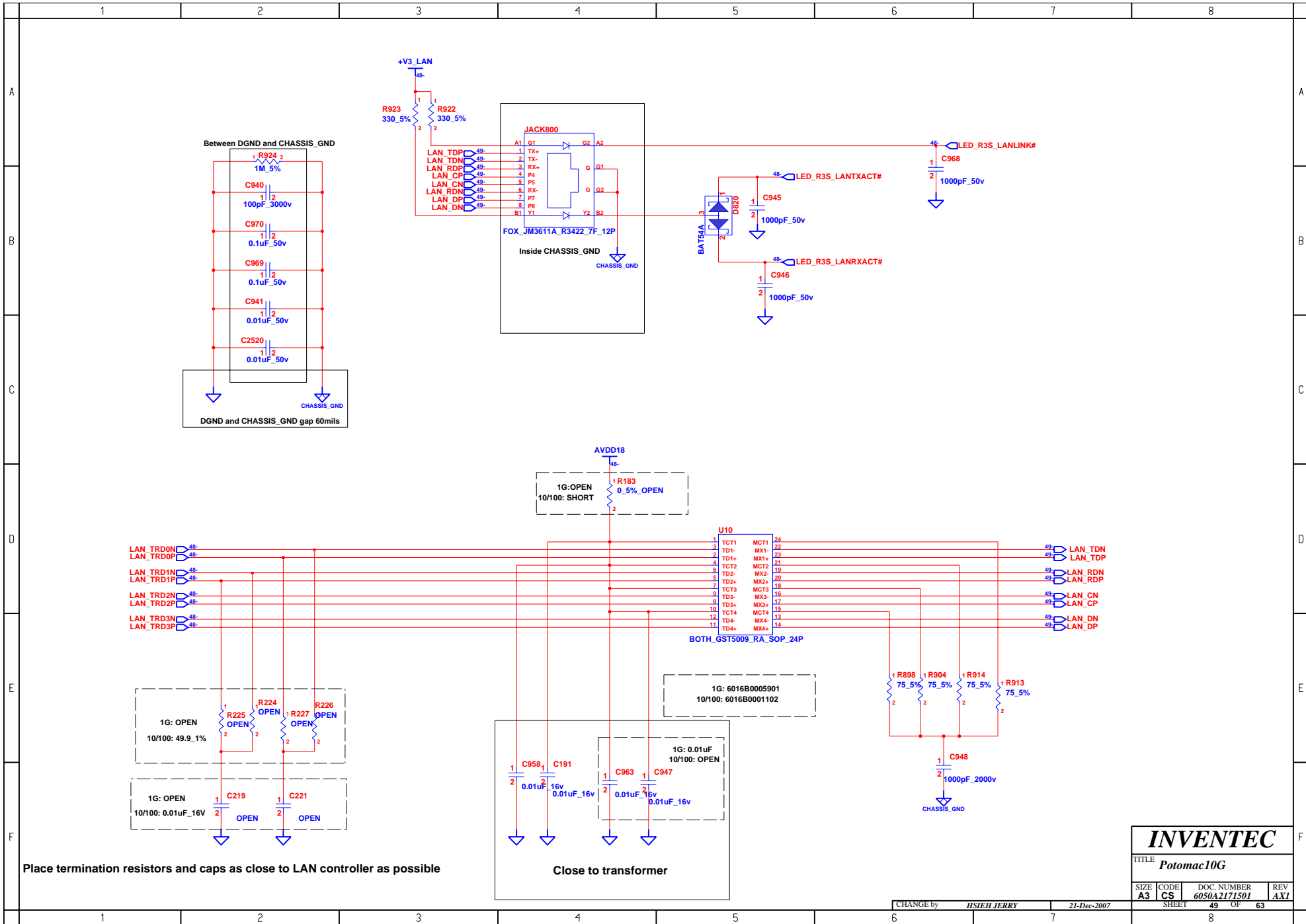

Place termination resistors and caps as close to LAN controller as possible

Close to transformer

INVENTEC			
TITLE <i>Potomac10G</i>			
SIZE A3	CODE CS	DOC. NUMBER 6050A2171501	REV AX1
CHANGE by <i>HSEIH JERRY</i>		21-Dec-2007	
SHEET 49		OF 63	

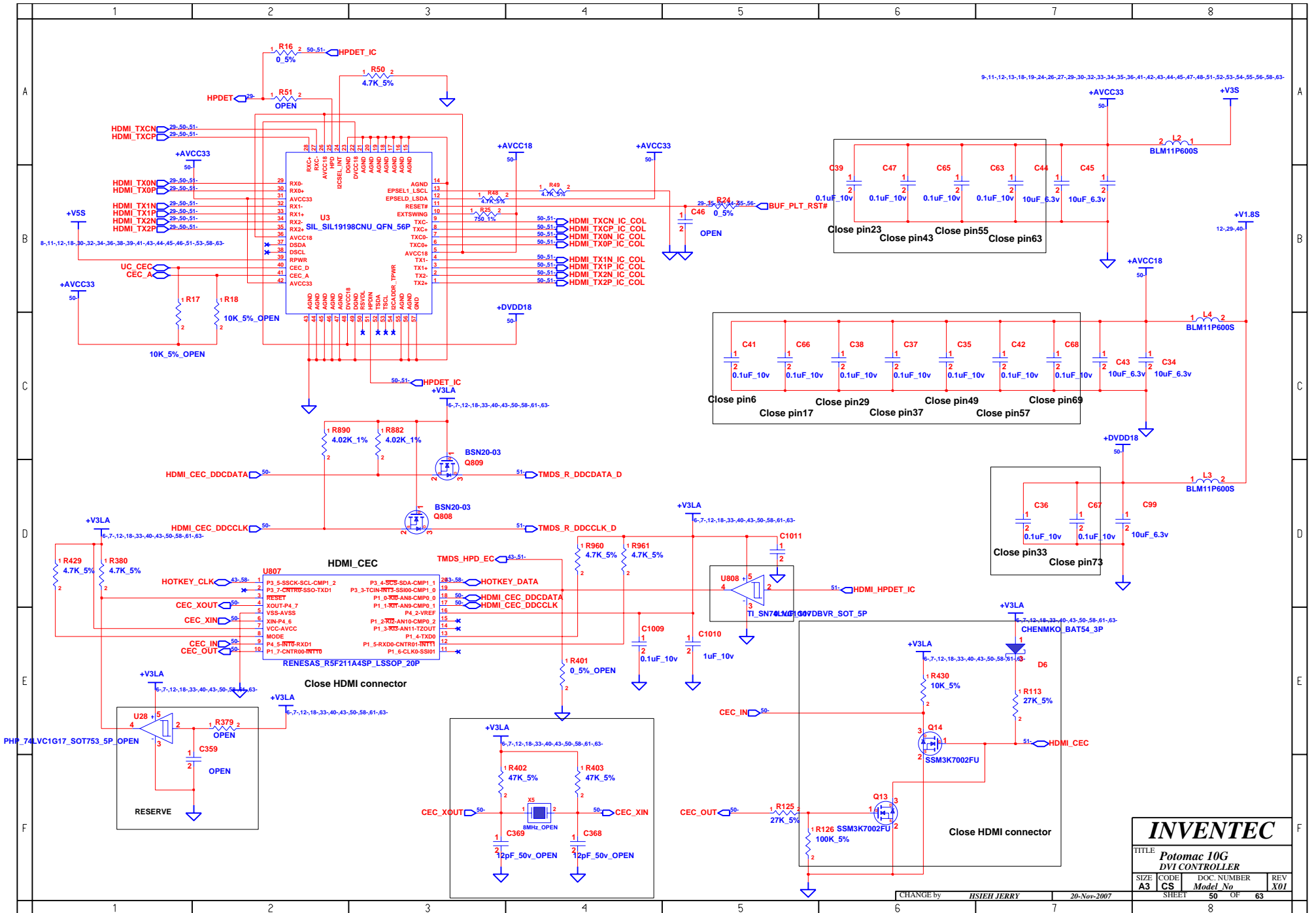

INVENTEC

TITLE
Potomac 10G
DVI CONTROLLER

SIZE	CODE	DOC. NUMBER	REV
A3	CS	Model No	X01

CHANGE by **HSIEH JERRY** 20-Nov-2007
 SHEET 50 OF 63

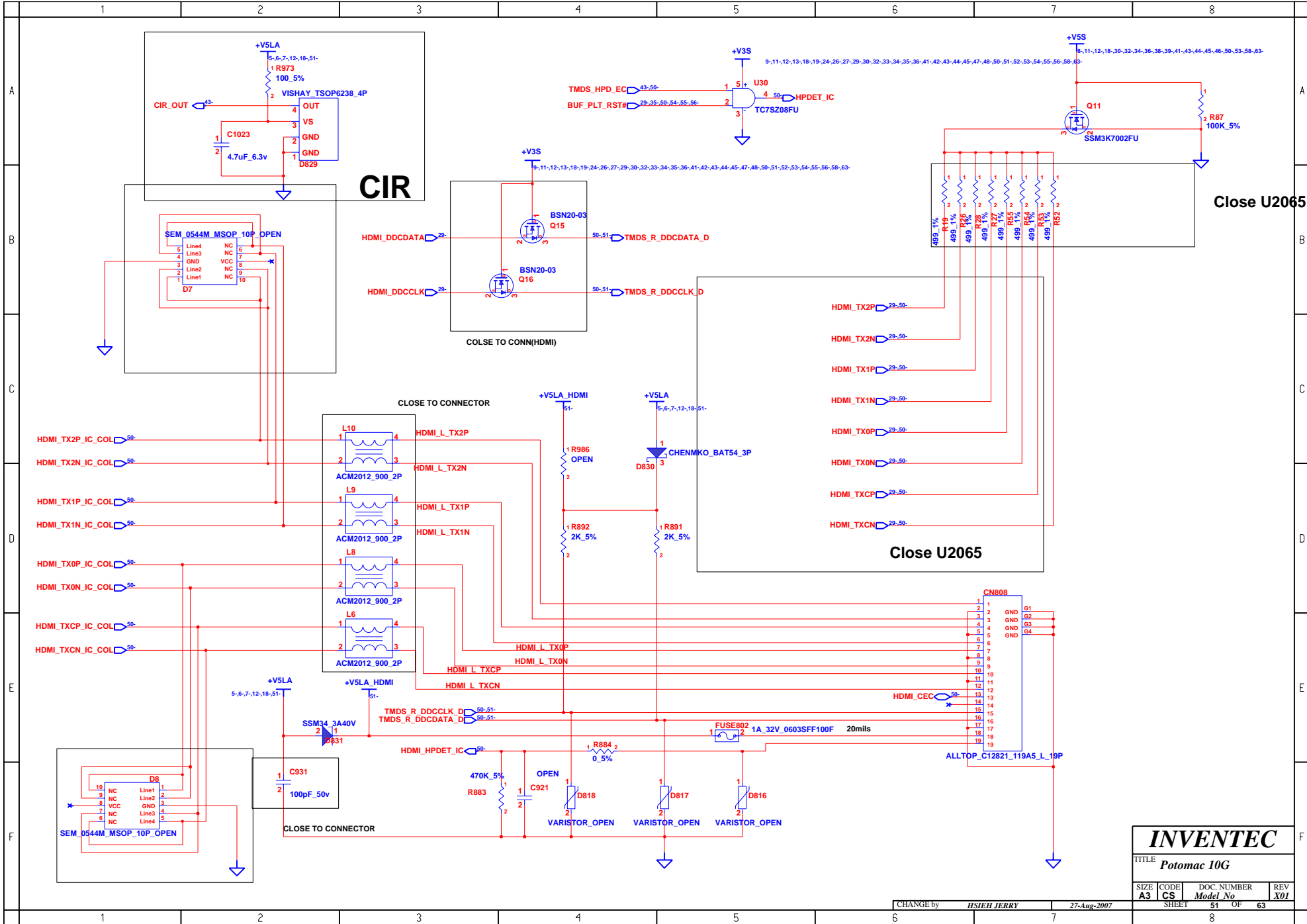

INVENTEC			
TITLE Potomac 10G			
SIZE A3	CODE CS	DOC. NUMBER <i>Model No</i>	REV X01
CHANGE by <i>HSEH JERRY</i>		27-Aug-2007	
SHEET 51		OF 63	

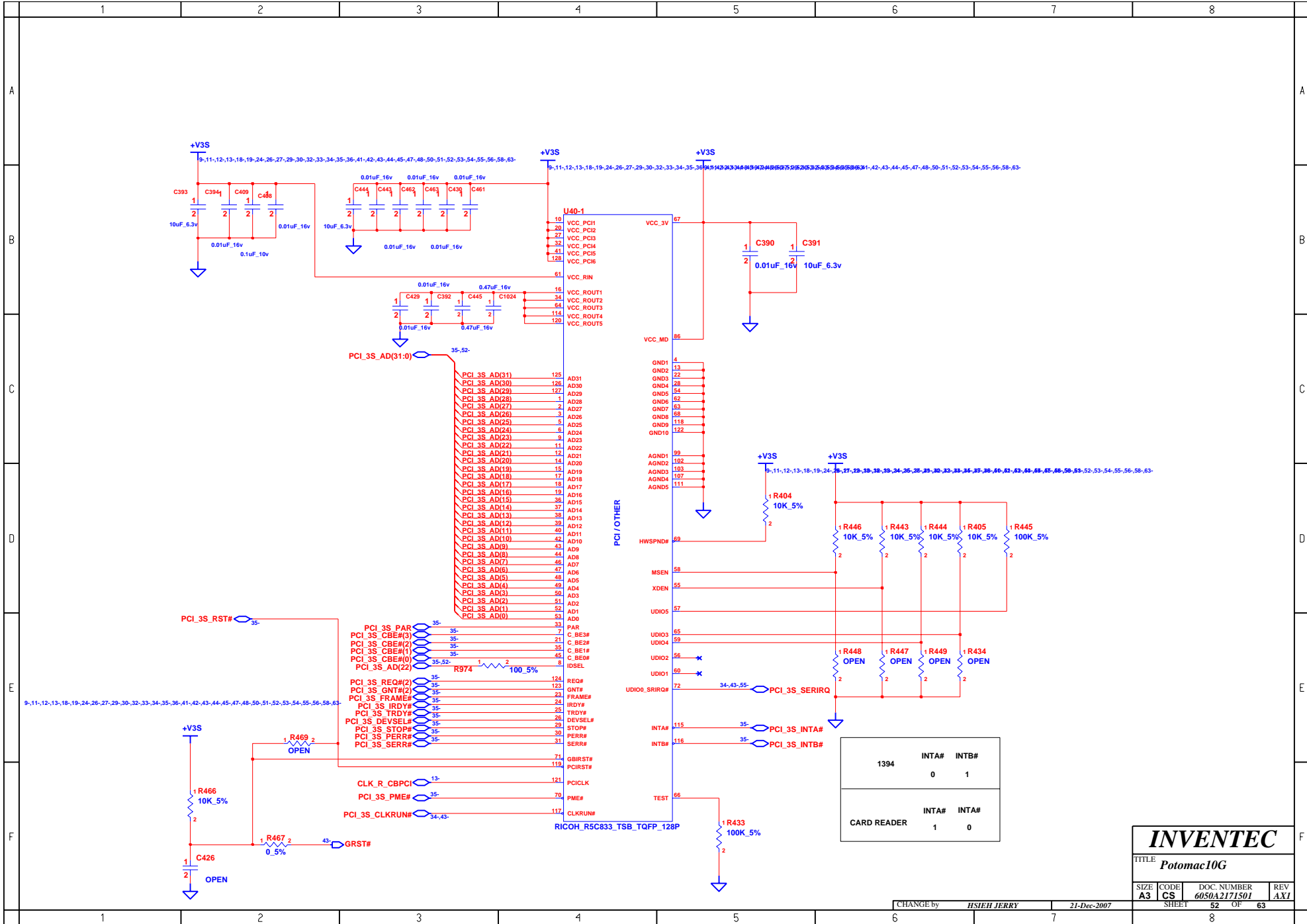

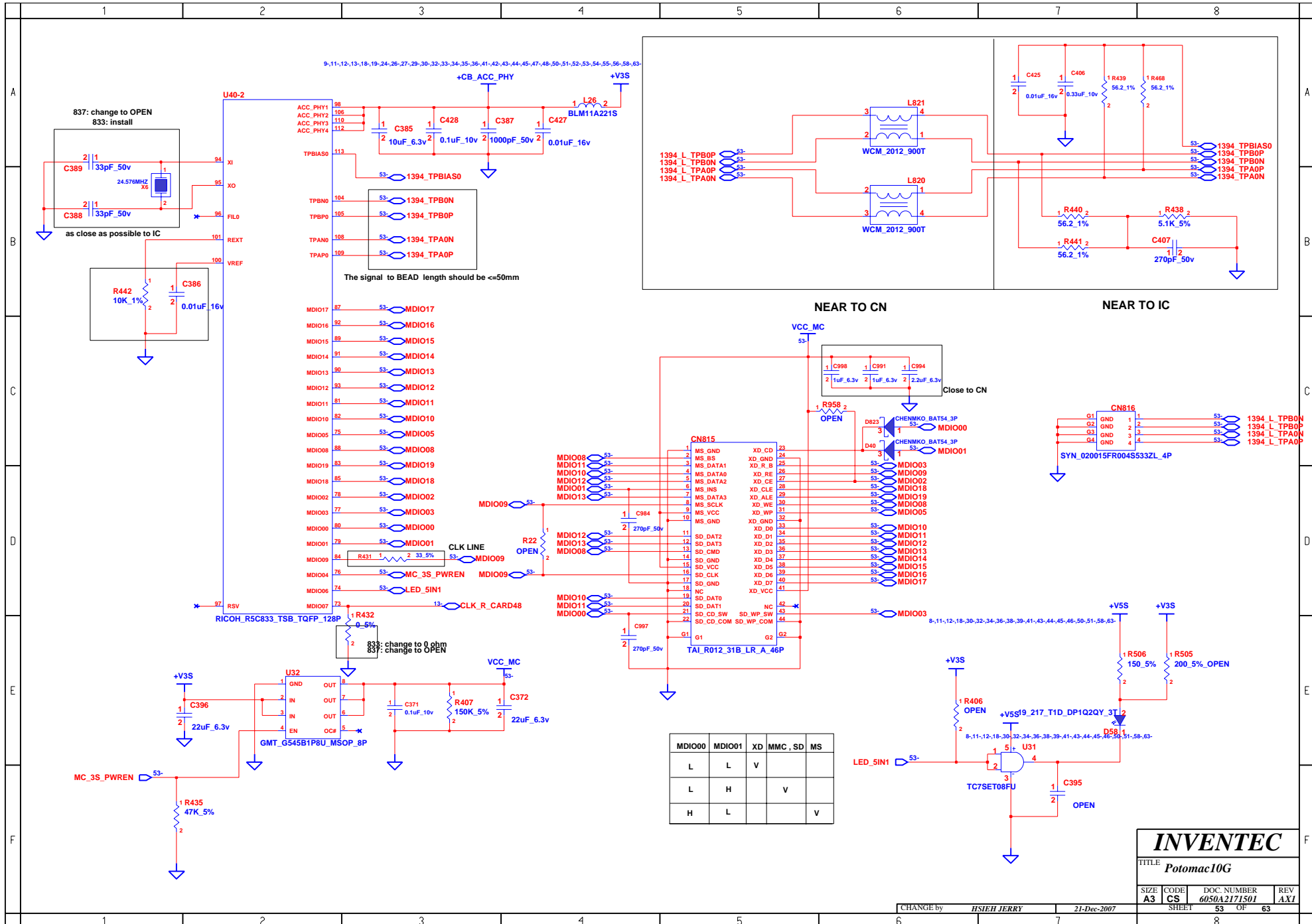

INVENTEC

TITLE
Potomac10G

SIZE	CODE	DOC. NUMBER	REV
A3	CS	6050A2171501	AX1

CHANGE by **HSEIH JERRY** 21-Dec-2007

SHEET 53 OF 63

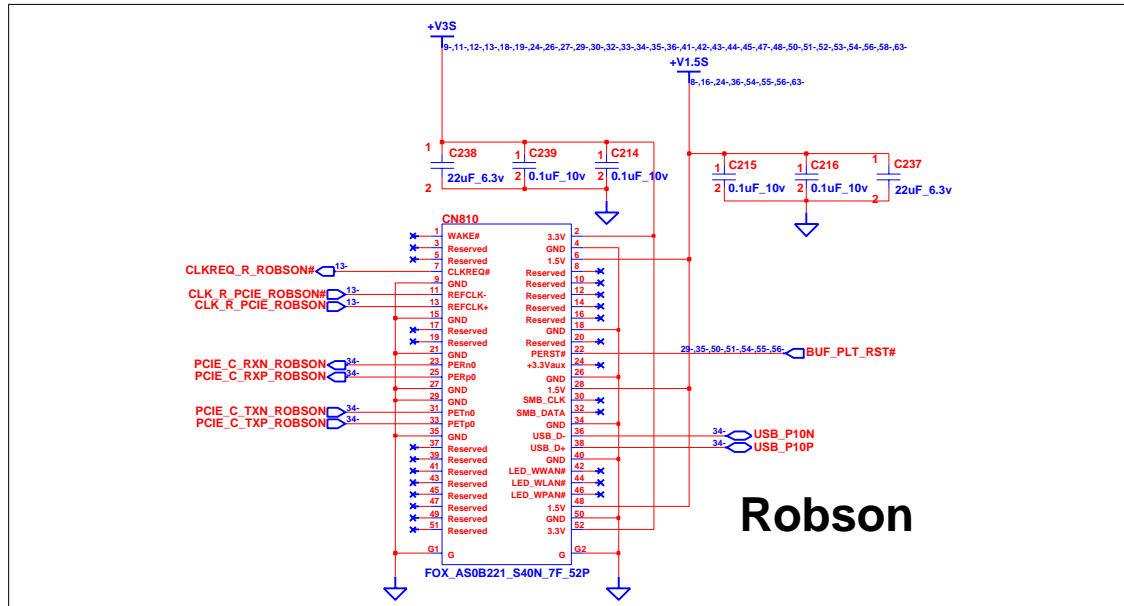

Robson

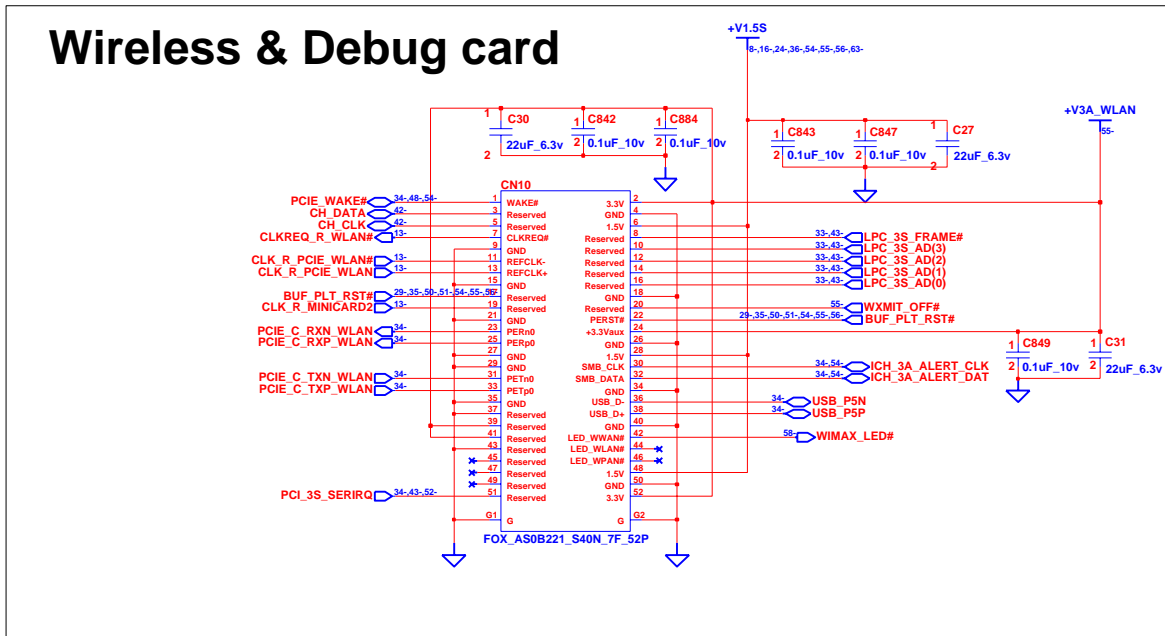

Wireless & Debug card

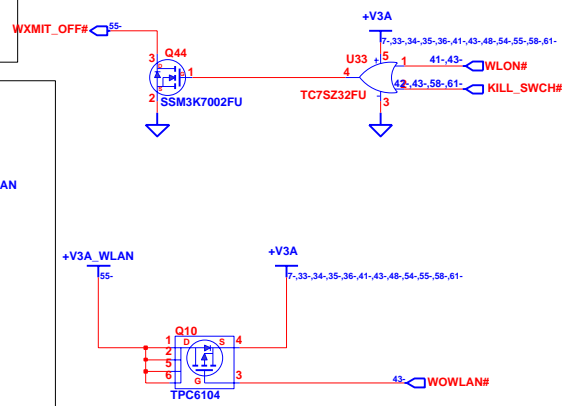

INVENTEC			
TITLE Potomac10G MINI CARD & SIM			
SIZE A3	CODE CS	DOC. NUMBER 6050A2171501	REV AX1
CHANGE by HSEIH JERRY		21-Dec-2007	
SHEET 55		OF 63	

HD-DVD Bordcom

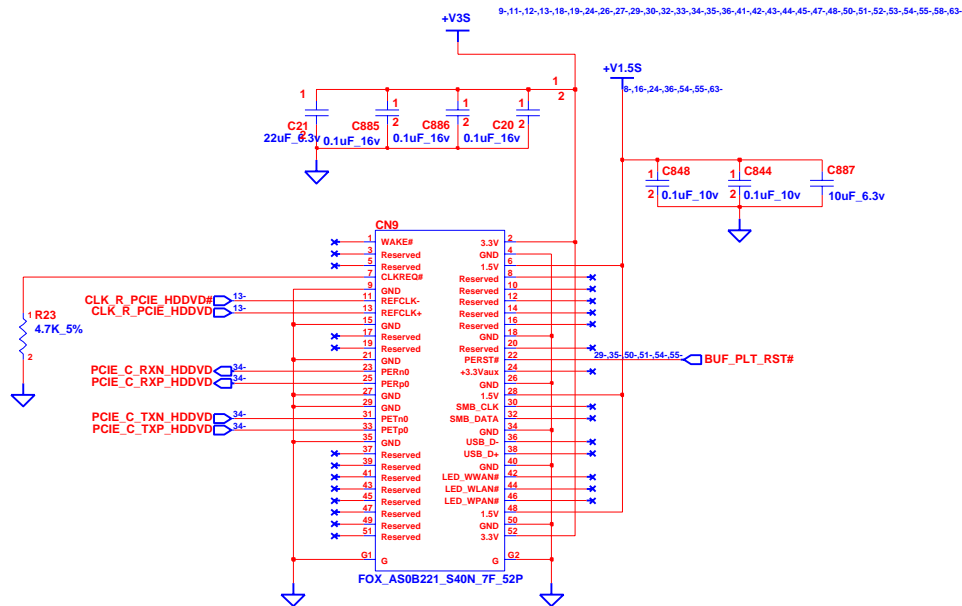

INVENTEC			
TITLE Potomac10G			
SIZE A3	CODE CS	DOC. NUMBER 6050A2171501	REV AX1
CHANGE by HSEH JERRY		21-Dec-2007	
SHEET 56		OF 63	

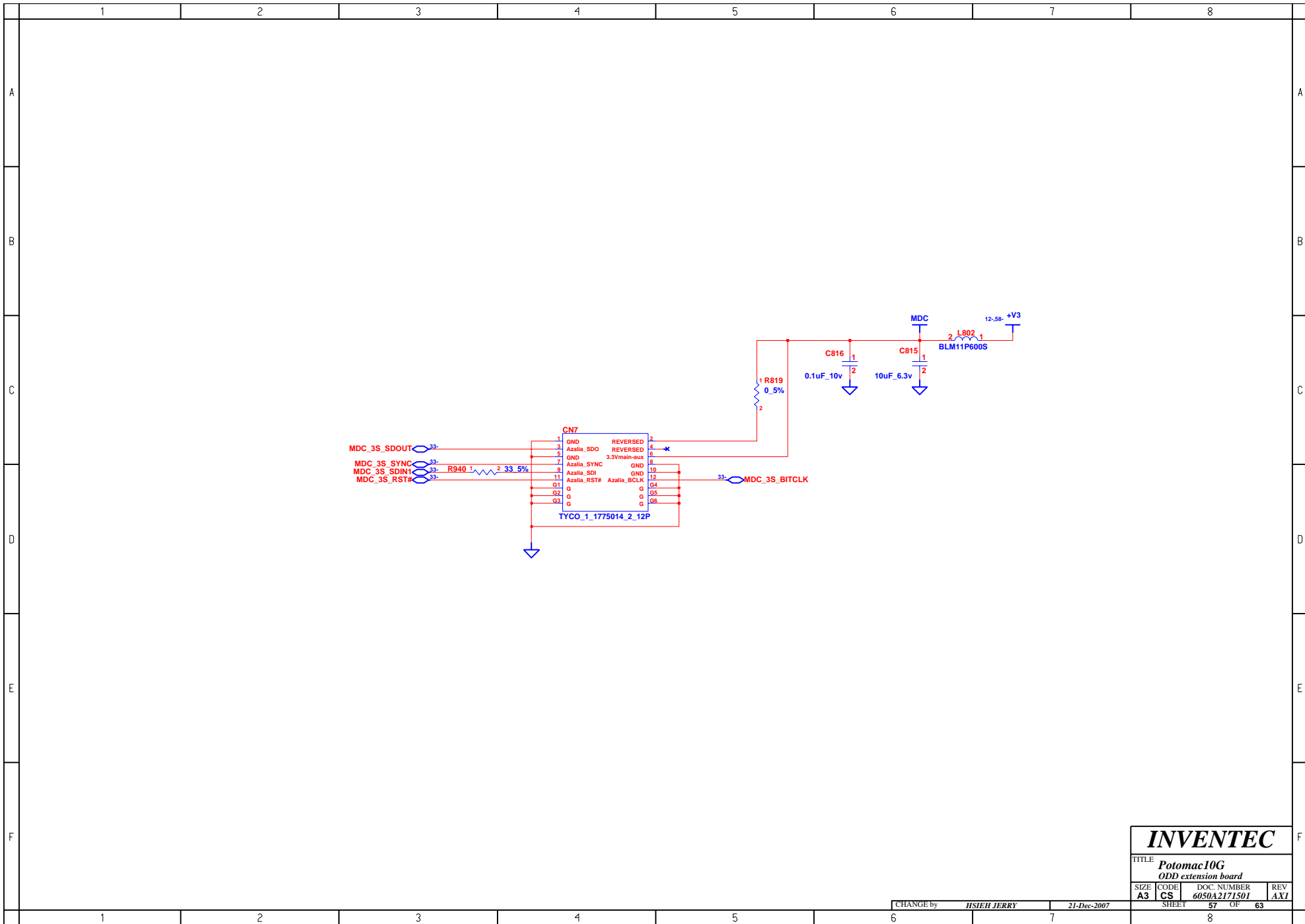

INVENTEC

TITLE			
Potomac10G			
ODD extension board			
SIZE	CODE	DOC. NUMBER	REV
A3	CS	6050A2171501	AX1

CHANGE by	HSEH JERRY	21-Dec-2007	SHEET	57	OF	63
-----------	------------	-------------	-------	----	----	----

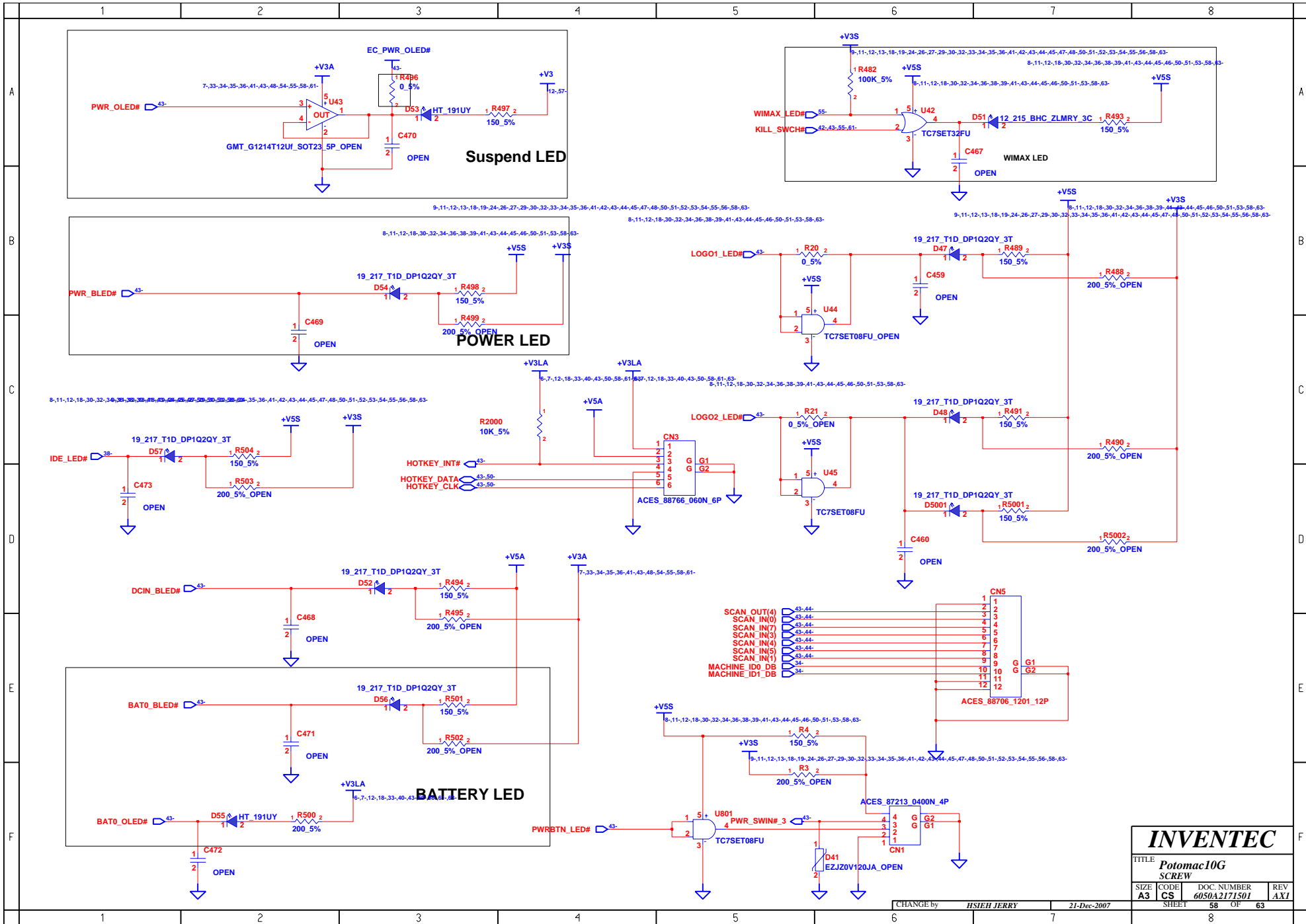

INVENTEC			
TITLE Potomac10G SCREW			
SIZE A3	CODE CS	DOC. NUMBER 6050A2171501	REV AX1
CHANGE by HSEIH JERRY		21-Dec-2007	
SHEET 58		OF 63	

Finger Print Reader DB

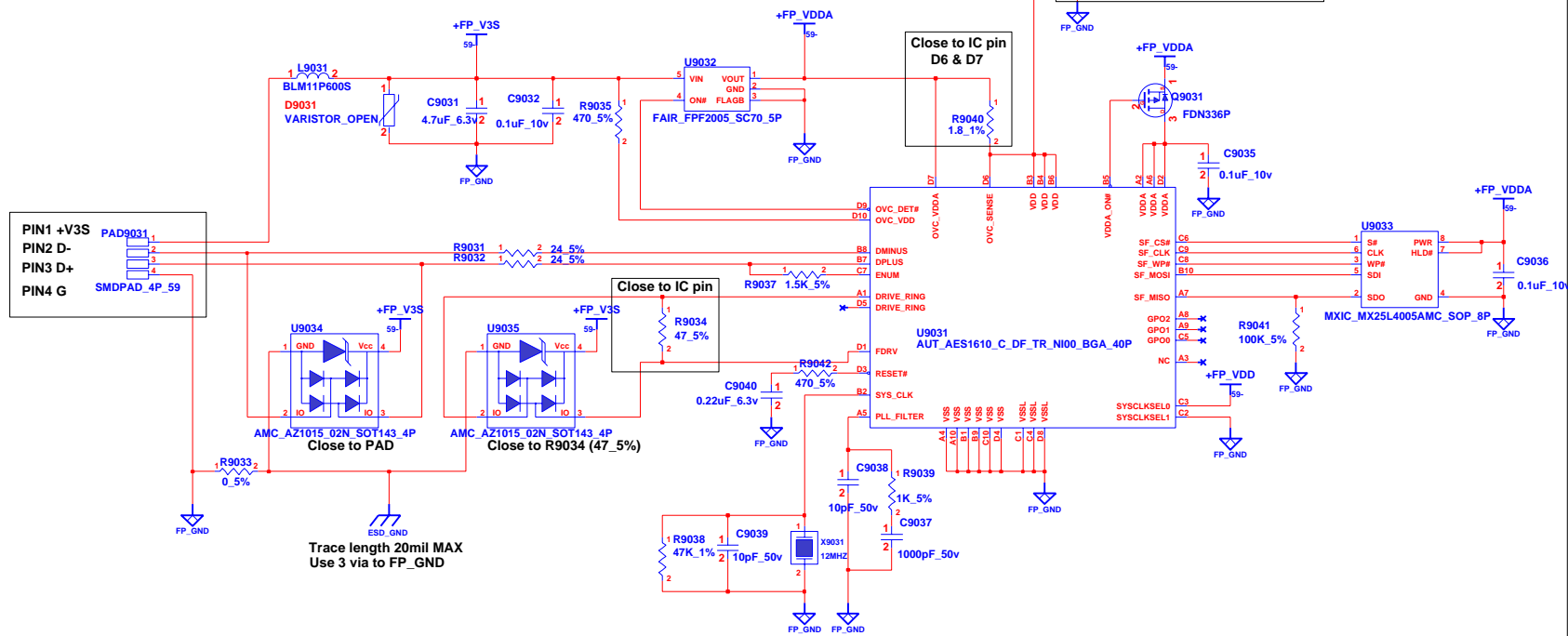

Trace length 20mil MAX
Use 3 via to FP_GND

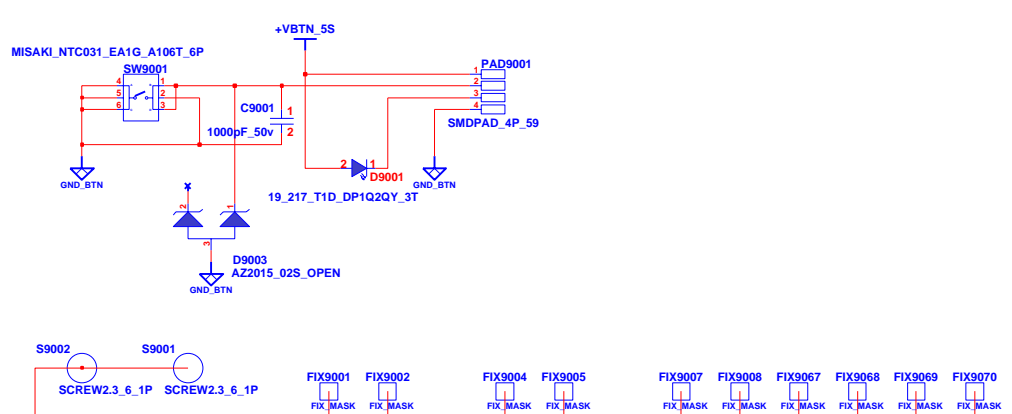

POWER BOARD

INVENTEC			
TITLE Potomac10G Switch board Conn			
SIZE A3	CODE CS	DOC NUMBER 6050A2171501	REV AX1
CHANGE by HSEH JERRY		21-Feb-2008	
SHEET 59		OF 63	

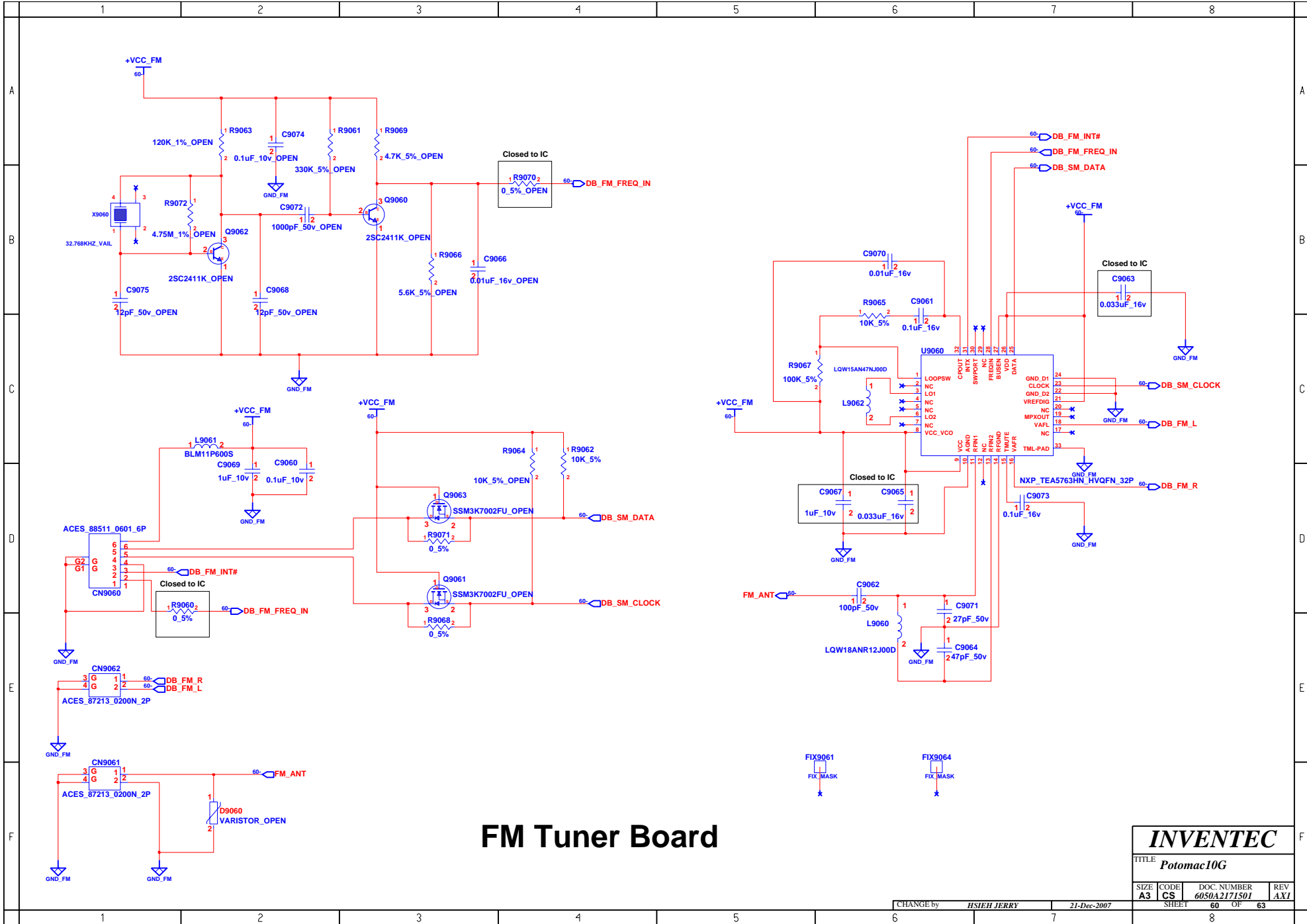

FM Tuner Board

INVENTEC			
TITLE <i>Potomac10G</i>			
SIZE A3	CODE CS	DOC. NUMBER 6050A2171501	REV AX1
CHANGE by HSEIH JERRY		21-Dec-2007	
SHEET 60		OF 63	

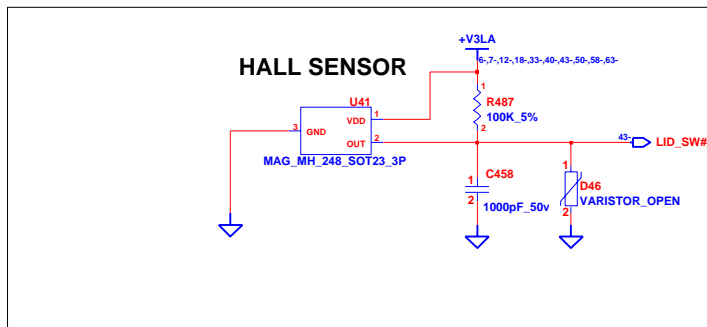
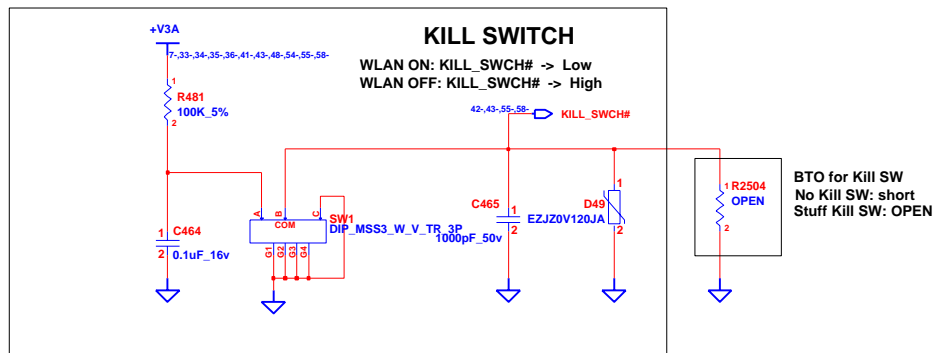

INVENTEC

TITLE			
Potomac10G Finger Print board			
SIZE	CODE	DOC. NUMBER	REV
A3	CS	6050A2171501	AX1
SHEET		61	OF 63

CHANGE by HSEH JERRY 21-Dec-2007

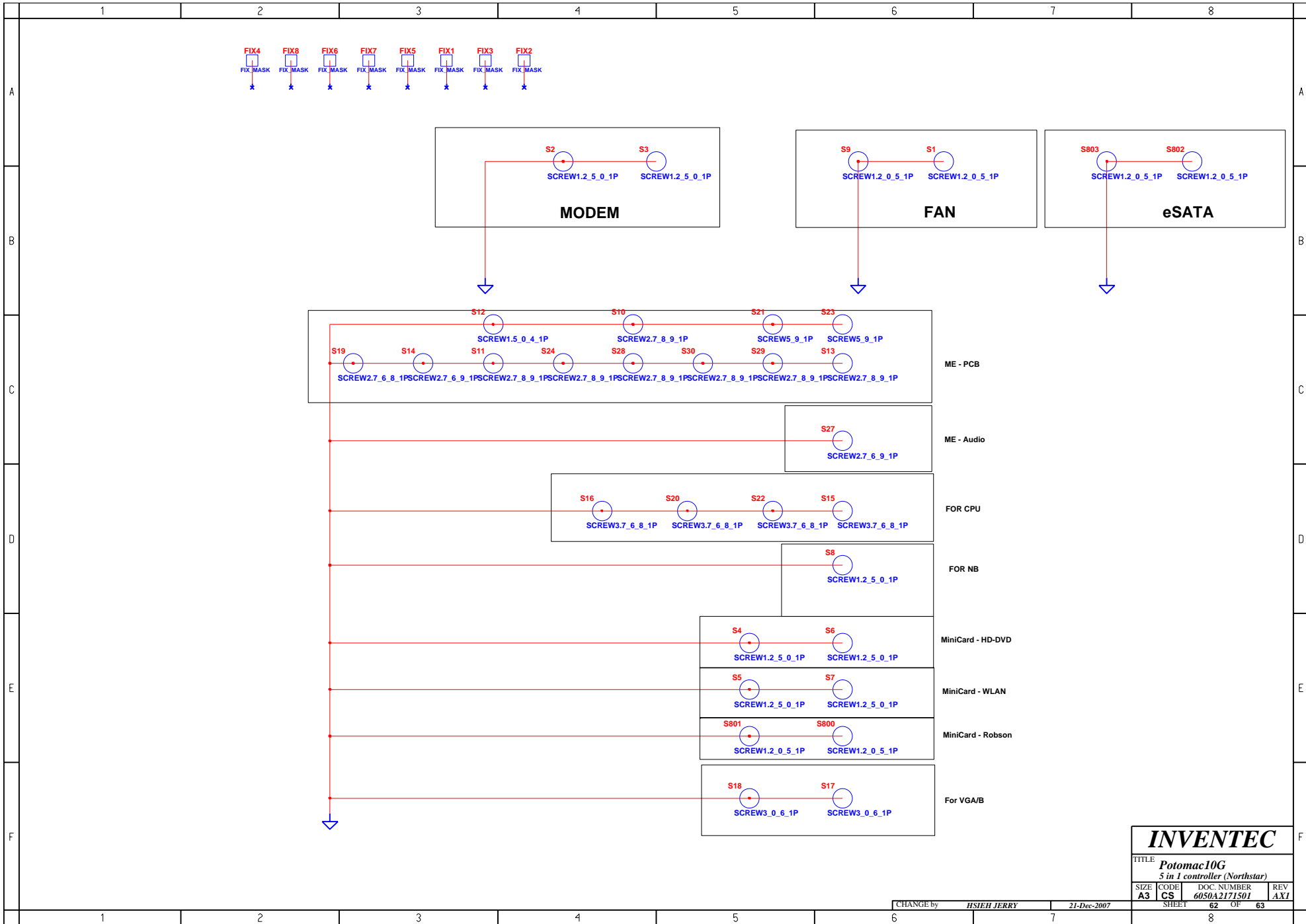

INVENTEC			
TITLE Potomac10G 5 in 1 controller (Northstar)			
SIZE A3	CODE CS	DOC. NUMBER 6050A2171501	REV AX1
CHANGE by HSEIH JERRY		21-Dec-2007	
SHEET		62 OF 63	

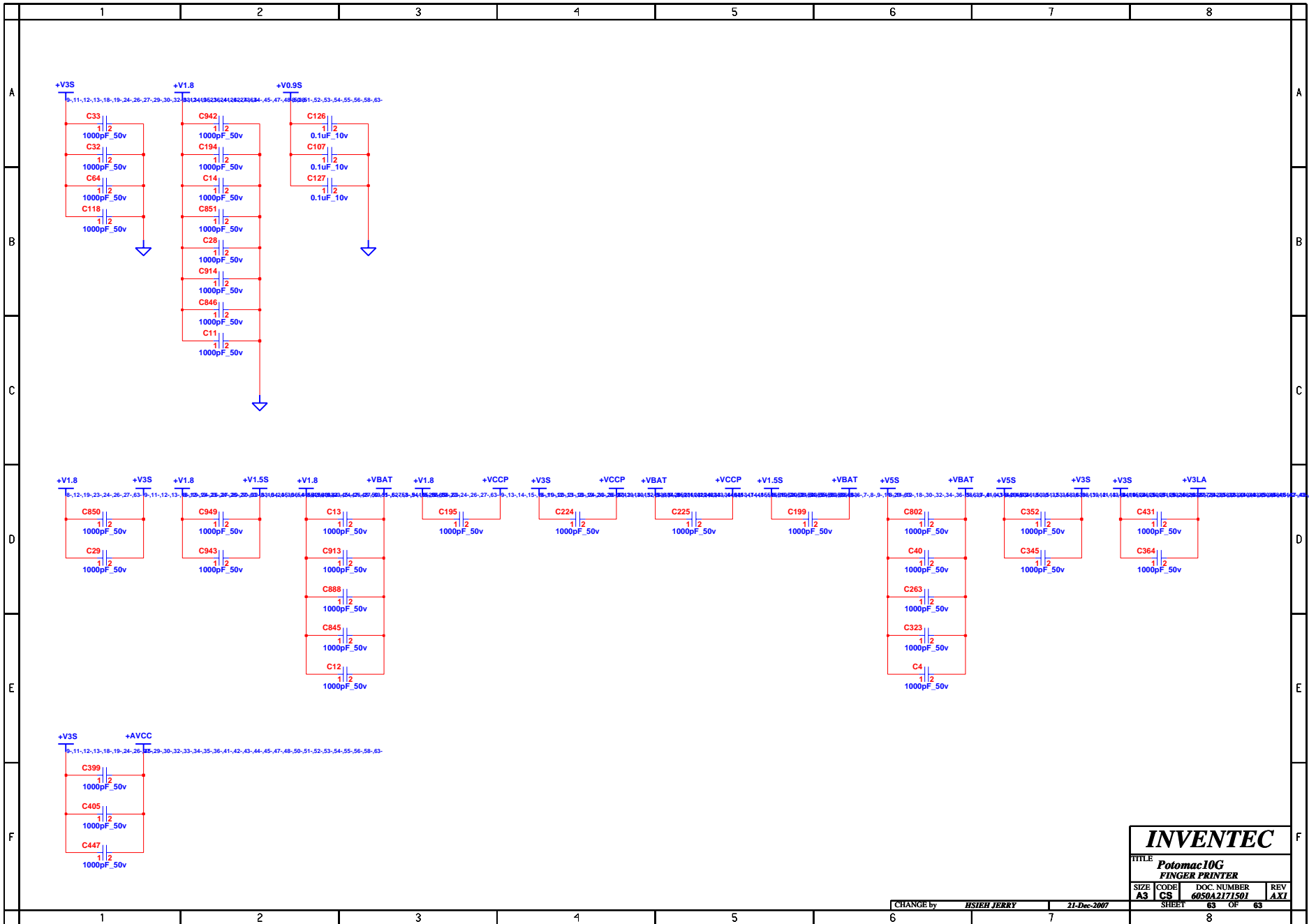

INVENTEC

TITLE **Potomac10G**
FINGER PRINTER

SIZE A3	CODE CS	DOC NUMBER 6050A2171501	REV AX1
----------------	----------------	--------------------------------	----------------

CHANGE by **HSIEH JERRY** 21-Dec-2007 SHEET **63** OF **63**