

Mariana Block Diagram

VTERM(+0.9V)
 VTT(+1.05V)
 +1.5VSUS
 +1.5V
 +1.8VSUS
 +1.8V
 +2.5V
 3VPCU
 +3.3V
 +3.3VSUS
 LCD_3.3V
 LCD_5V
 +5V

XDP

Thermal Sensor

8.9" or 12" LCD

CRT

**Diamondville
FCBGA8 437**
 VCORE:+1.196 ~ +0.748
 VCCP:+1.05V
 VCCA:+1.8V or +1.5V

**945GMS/GSE
FCBGA 998**

**ICH7M
BGA 652**

**CPU VCORE
IMVP 6**

**Clock Gengerator
CK505M**

**DDR2
400/533
SO-DIMM
RANK 2
(Up to 1GB)**

**DDR2 400/533
512MB DOWN
RANK 1
64M X 16 X 4**

RJ-45

**10/100 Ethernet
BCM5906**

HP/Mic
Audio
Jack

Int. Mic

**HDA CODEC
ALC269**

Int. SPK Amplify

34mm New Card

Int. KB

T/P

**ENE
KB3310**

**SPI
Flash**

Battery

Charger

VID[0:6]
 +/- CPU CLK
 +/- HCLK

SATA
 IDE
 PCI-e/USB
 USB
 USB
 USB
 USB

FSB 533MHz

CHB

SATA

IDE

PCI-e/USB

USB

USB

USB

USB

2.5" HDD

**SSD 4/8/16GB
(Option)**

Mini PCIe Slot

**Card Reader
RTL5158E**

USB PORT X 2

Camera Conn.

**Bluetooth
(Option)**

CHA

WLAN / WWAN Module

**4 in 1 Socket
SD/MMC/MS/MS-Pro**

**Camera Module
(Option)**

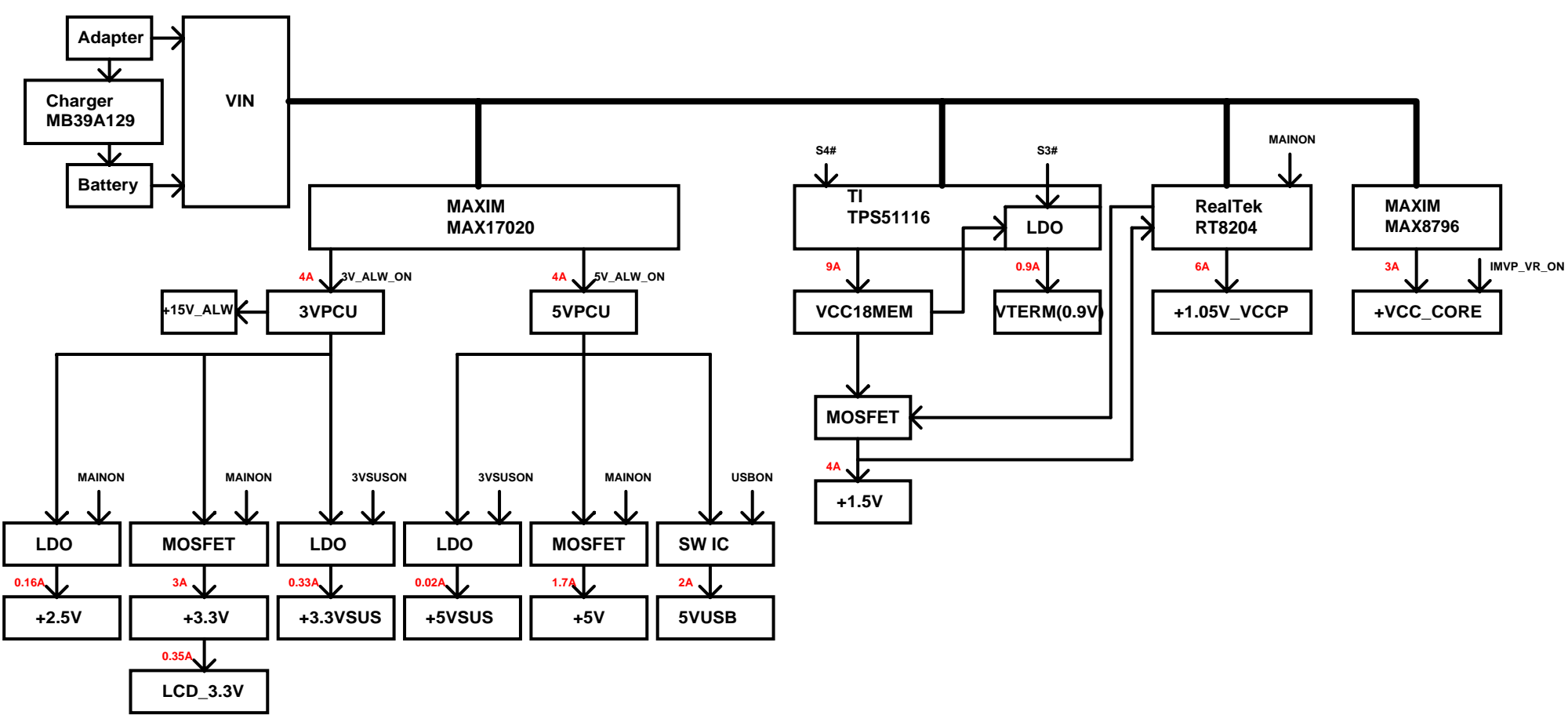

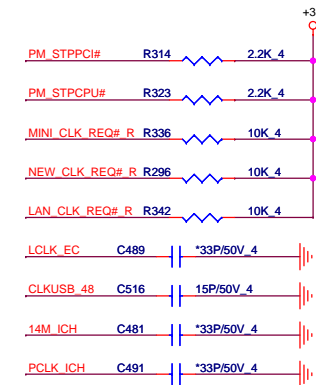
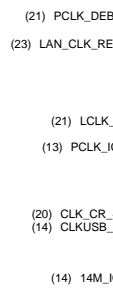
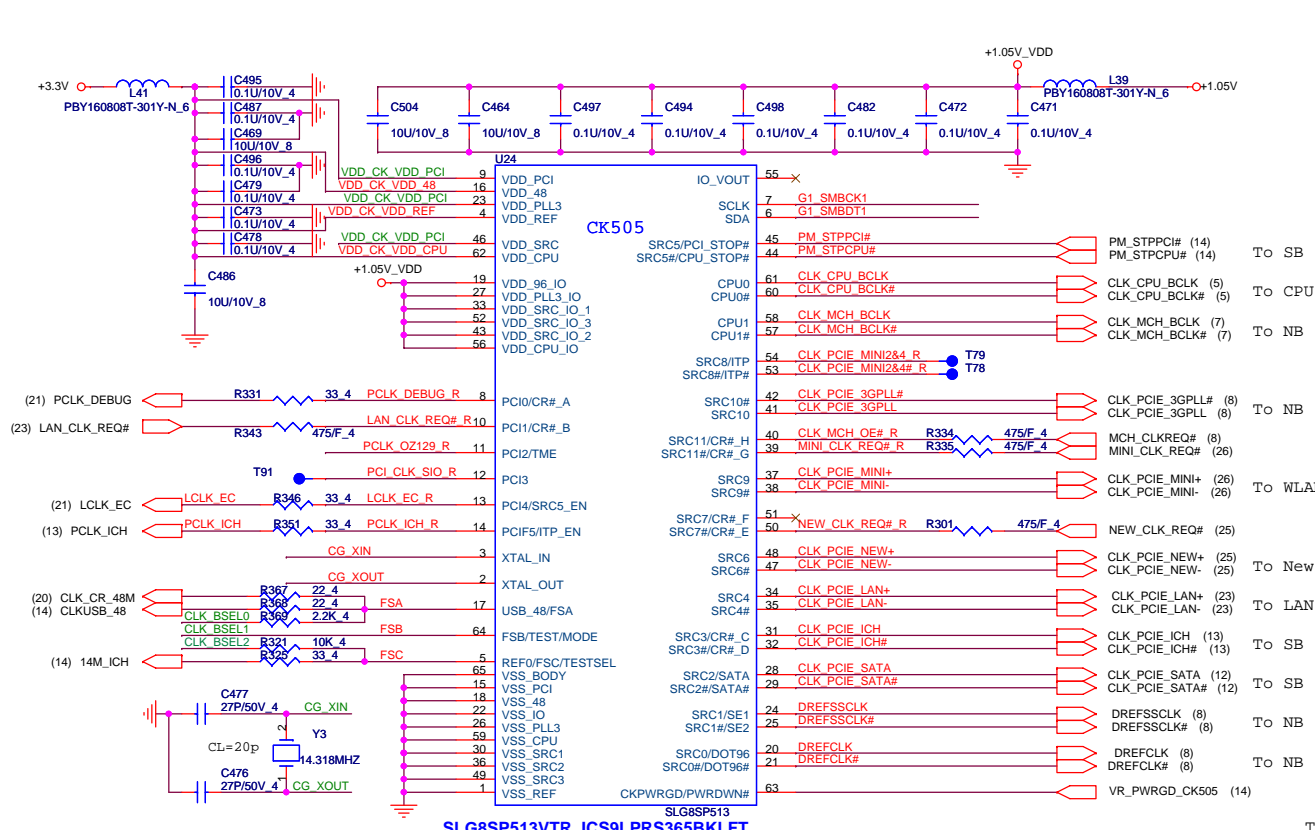

SEL2 SEL1 SEL0 Frequency select

FSC	FSB	FSA	CPU	SRC	PCI
1	0	1	100	100	33
0	0	1	133	100	33
0	1	1	166	100	33
0	1	0	200	100	33
0	0	0	266	100	33
1	0	0	333	100	33
1	1	0	400	100	33
1	1	1	Reserved		

Default

Pin	Signal	Configuration	Default
Pin 11	PCI2/TME	PCI2/TME Internal PD	NO OVERCLOCKING (default)
Pin 12	PCI-3	PCI-3/SRC5_EN Internal PD	PIN37/38 IS SRC5
Pin 13	PCI-4/27M_SEL	PCI-4/27M_SEL Internal PD	PIN 17/18 IS 27MHz
Pin 14	PCIF-5/ITP_EN	PCIF-5/ITP_EN Internal PD	PIN 46/47 IS CPUITP

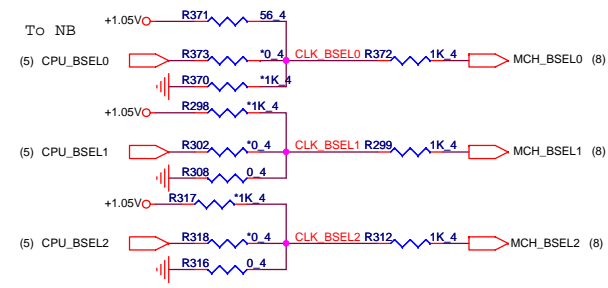
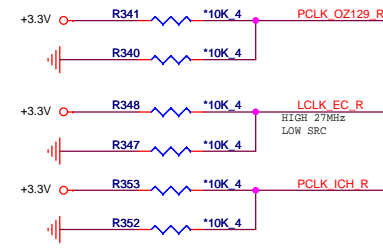

Clock Gen I2C

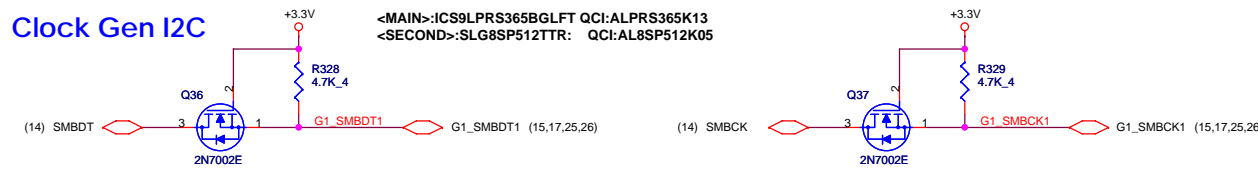

<MAIN>:ICS9LPRS365BGLFT QCI:ALPRS365K13
 <SECOND>:SLG8SP512TTR: QCI:AL8SP512K05

SM_BUS_Group1

1. Clock Gen
2. Memory Rom
3. Mini Card
4. New Card
5. CPU Thermal Monitor

Quanta Computer Inc.
 PROJECT : FL1

Size	Document Number	Rev
		1A
CLOCK GENERATOR		
Date:	Saturday, June 07, 2008	Sheet 4 of 34

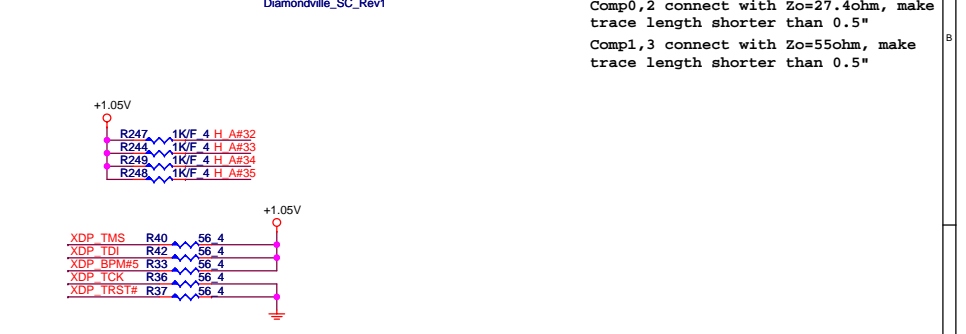
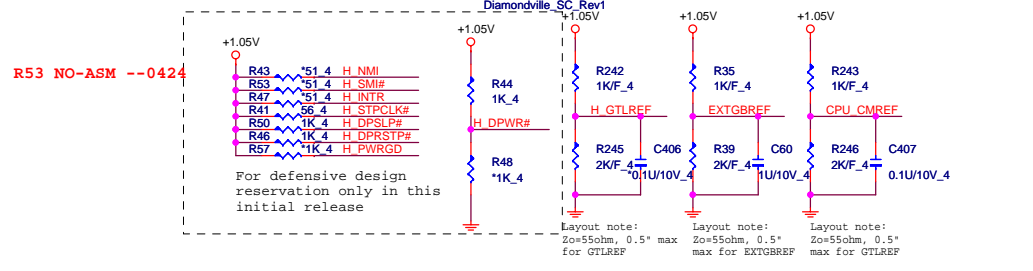
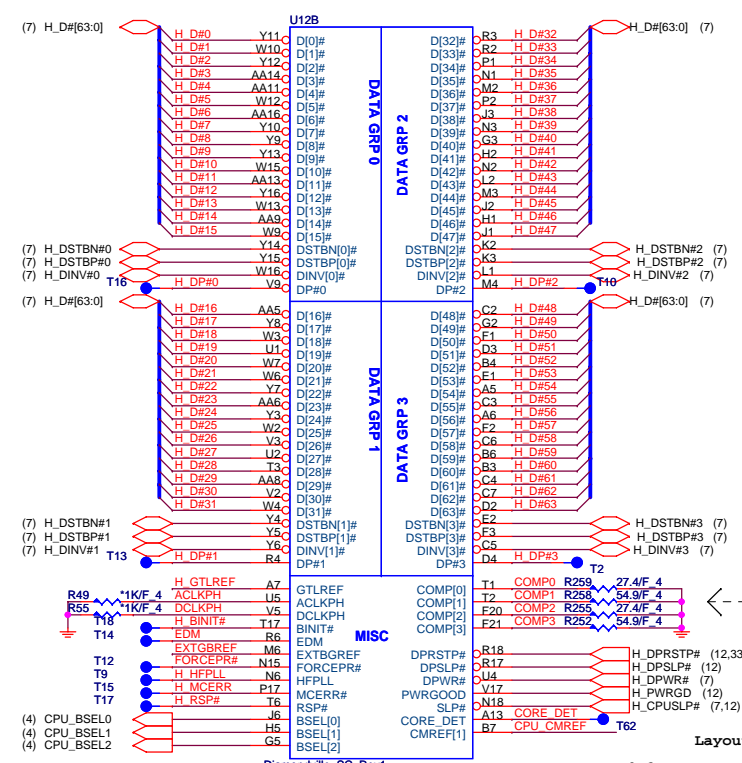
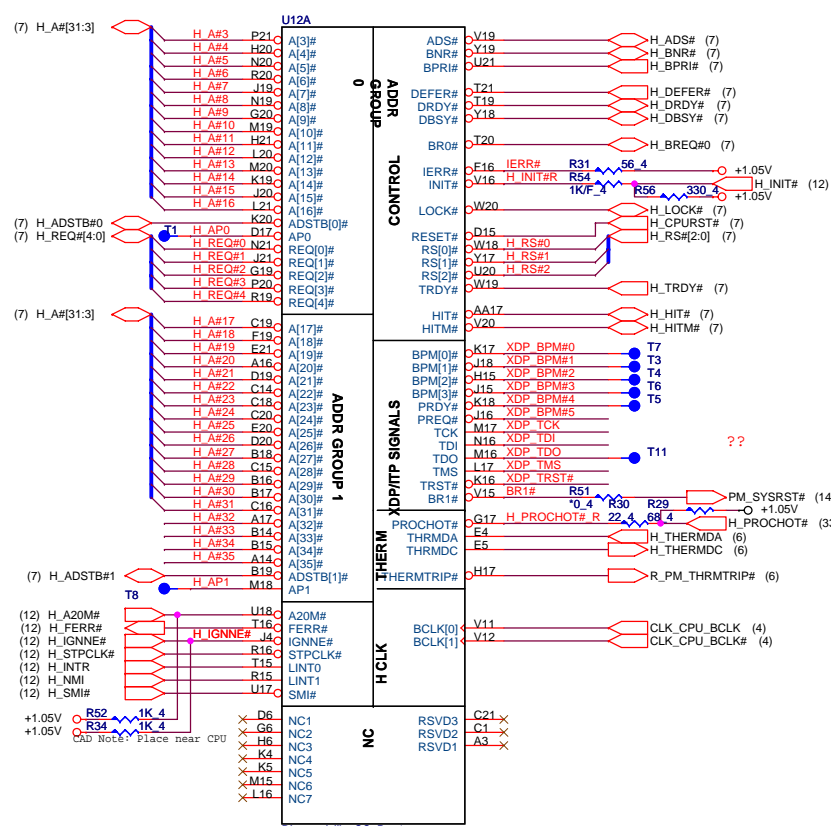

Layout note:
 Comp0,2 connect with Zo=27.4ohm, make trace length shorter than 0.5"
 Comp1,3 connect with Zo=55ohm, make trace length shorter than 0.5"

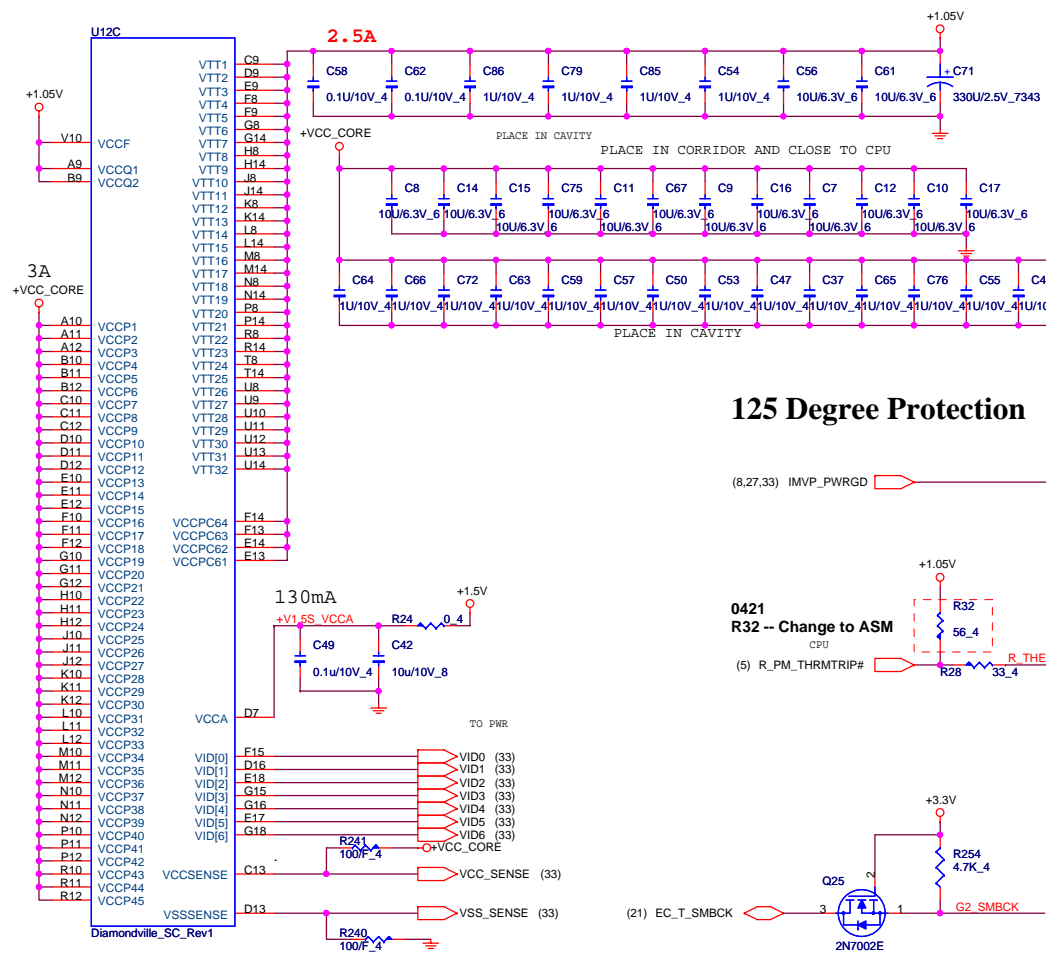
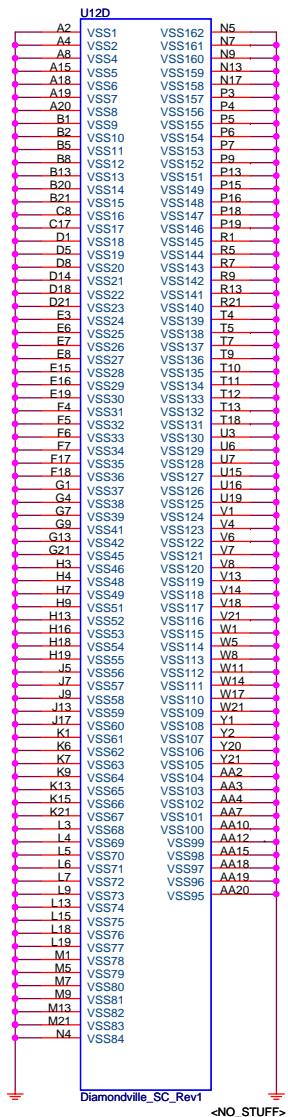

125 Degree Protection

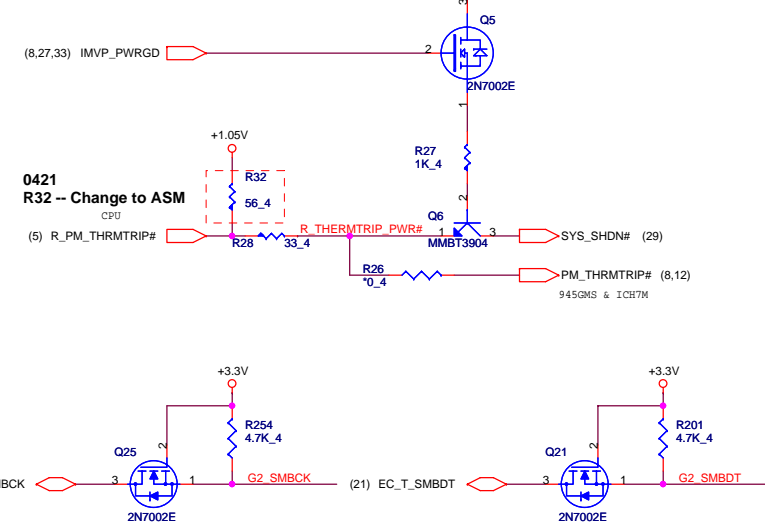

CPU Thermal monitor

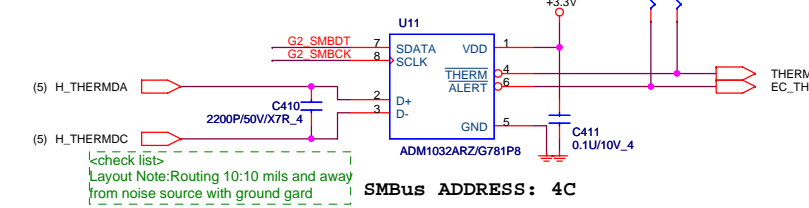

Check list:
Layout Note: Routing 10:10 mils and away from noise source with ground guard

SMBus ADDRESS: 4C

Quanta Computer Inc.
PROJECT : FL1

Size	Document Number	Rev
Date: Saturday, June 07, 2008	Diamondville (2/2)	1A
Sheet	6	of 34

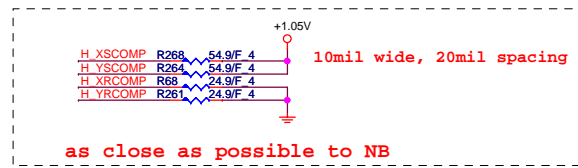
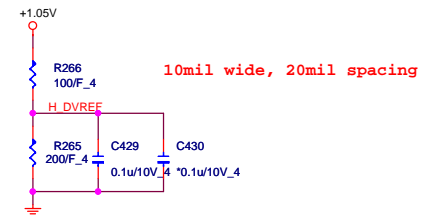
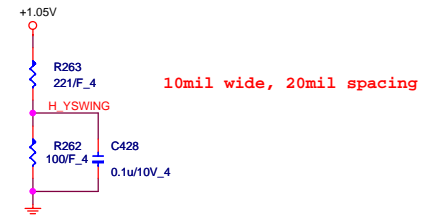
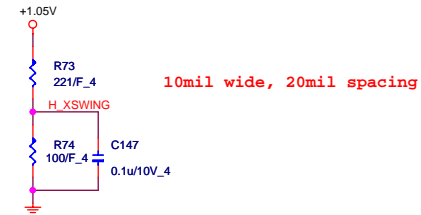
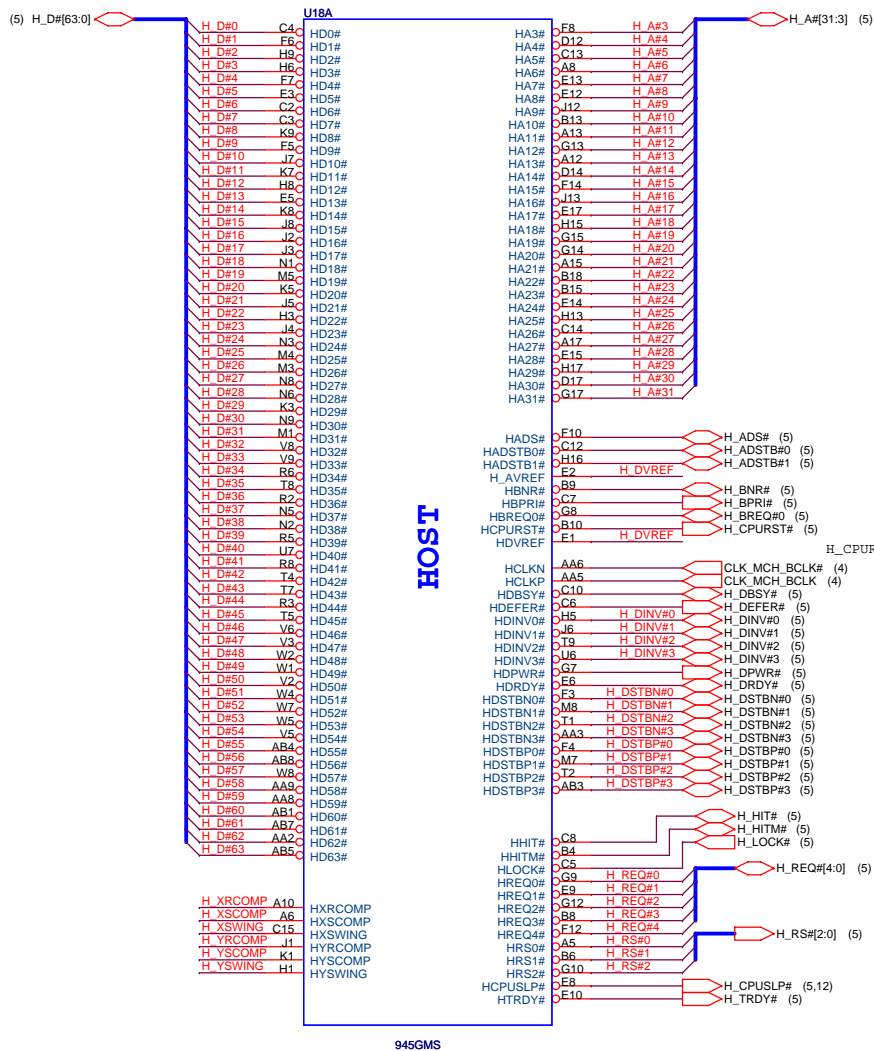

H_CPURST# has T topology

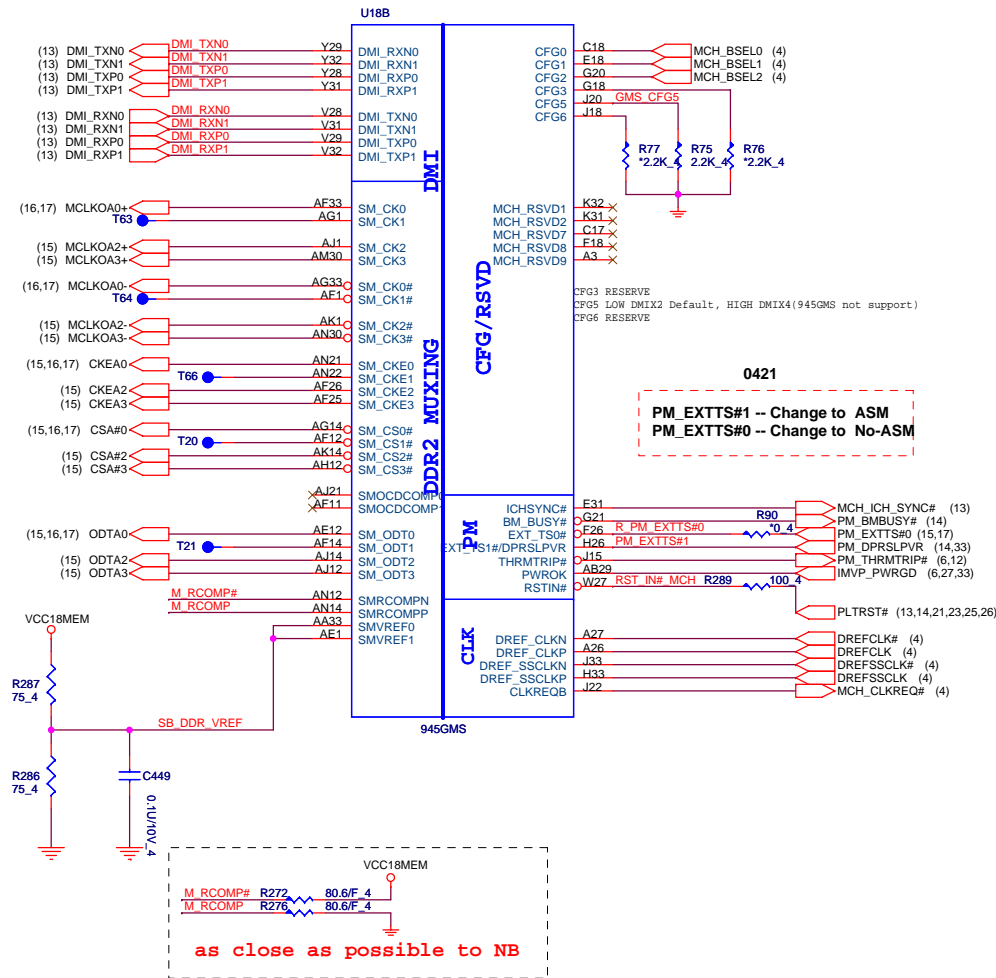

as close as possible to NB
 VGA_BLU -- R (150)
 VGA_GRN -- R (150)
 VGA_RED -- R (150)

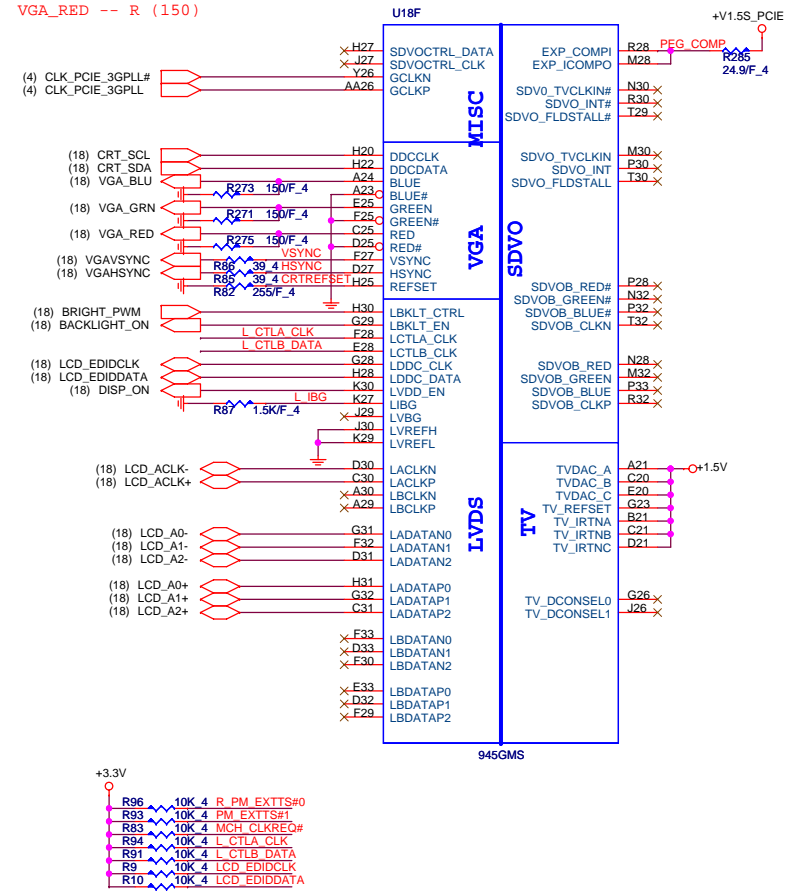

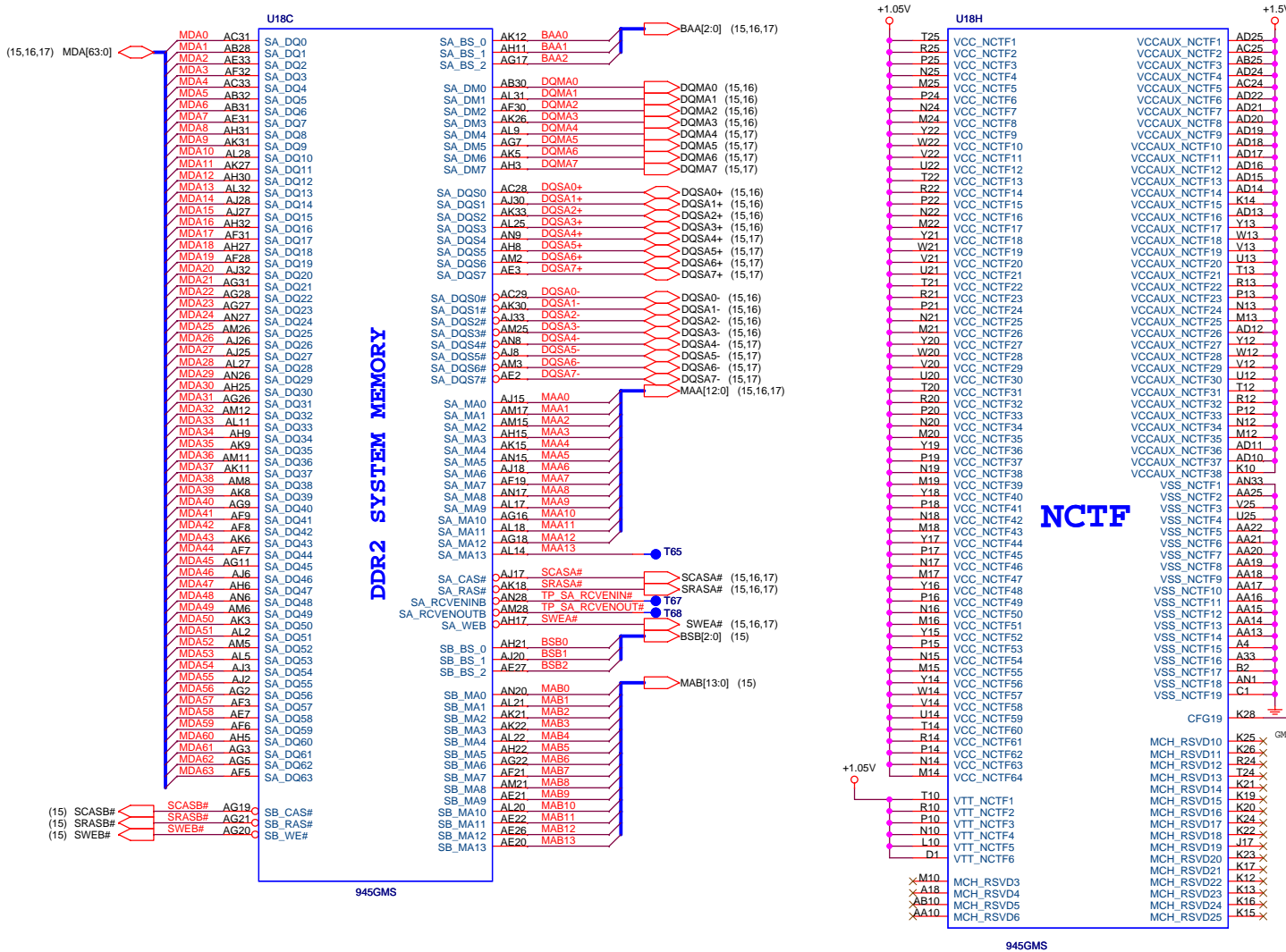

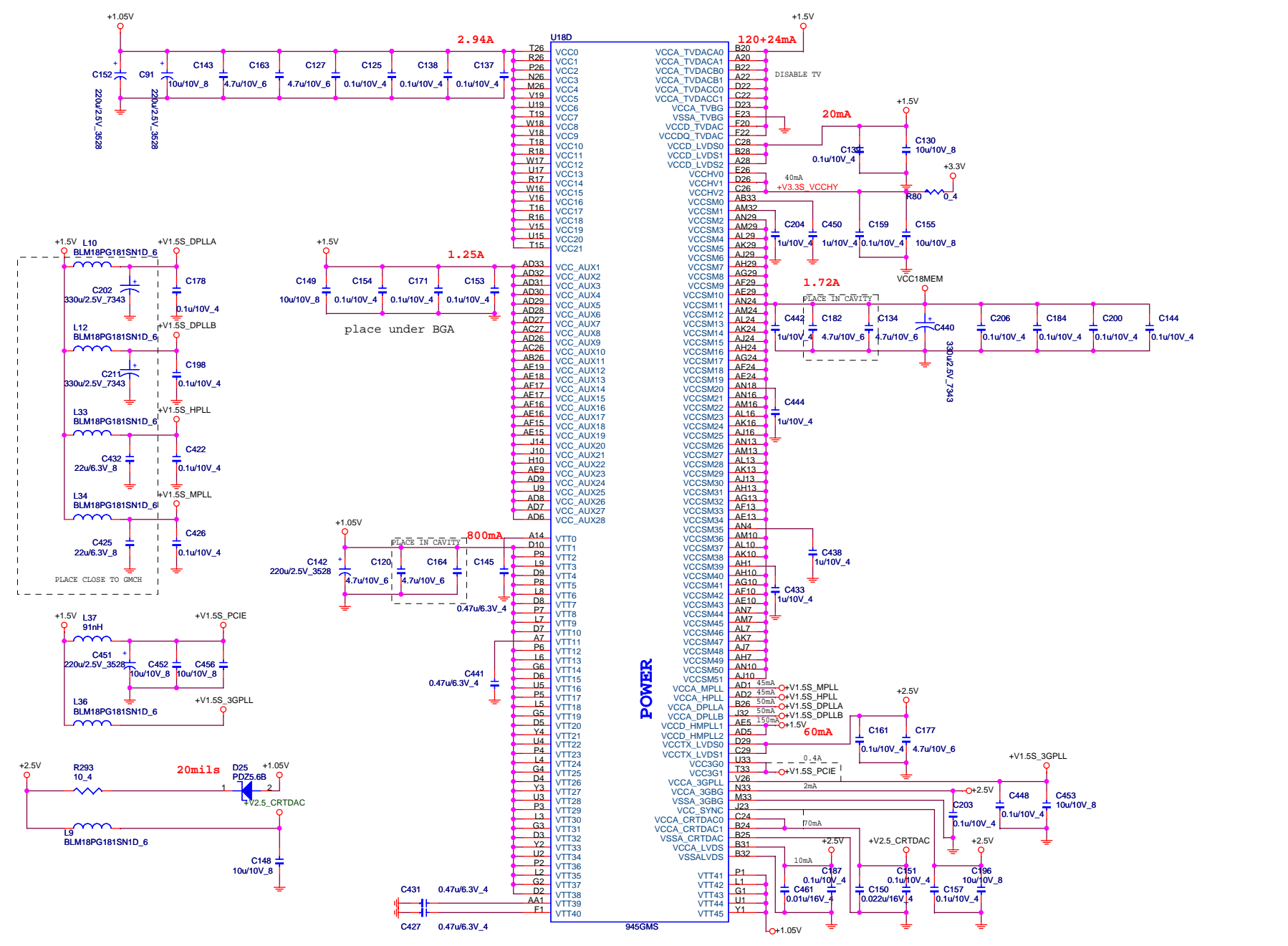

POWER

Quanta Computer Inc.
PROJECT : FL1

Size	Document Number	Rev
	945GMS_POWER	1A
Date:	Saturday, June 07, 2008	Sheet 10 of 34

U18E

AH33	VSS1	J16
Y33	VSS2	AL15
V33	VSS3	AG15
R33	VSS4	W15
G33	VSS5	R15
AK32	VSS6	F15
AG32	VSS7	D15
AE32	VSS8	AM14
AC32	VSS9	AH14
AA32	VSS10	VSS119
U32	VSS11	VSS120
H32	VSS12	VSS121
E32	VSS13	H14
C32	VSS14	B14
AM31	VSS15	VSS122
AJ31	VSS16	VSS123
AA31	VSS17	VSS124
U31	VSS18	VSS125
T31	VSS19	VSS126
R31	VSS20	VSS127
P31	VSS21	VSS128
M31	VSS22	VSS129
J31	VSS23	VSS130
F31	VSS24	VSS131
AL30	VSS25	VSS132
AG30	VSS26	VSS133
AE30	VSS27	VSS134
AC30	VSS28	VSS135
AA30	VSS29	VSS136
Y30	VSS30	VSS137
V30	VSS31	VSS138
U30	VSS32	VSS139
G30	VSS33	VSS140
E30	VSS34	VSS141
B30	VSS35	VSS142
AA29	VSS36	VSS143
U29	VSS37	VSS144
R29	VSS38	VSS145
P29	VSS39	VSS146
N29	VSS40	VSS147
M29	VSS41	VSS148
H29	VSS42	VSS149
E29	VSS43	VSS150
B29	VSS44	VSS151
AK28	VSS45	VSS152
AH28	VSS46	VSS153
AE28	VSS47	VSS154
AA28	VSS48	VSS155
U28	VSS49	VSS156
T28	VSS50	VSS157
J28	VSS51	VSS158
D28	VSS52	VSS159
AM27	VSS53	VSS160
AF27	VSS54	VSS161
AB27	VSS55	VSS162
AA27	VSS56	VSS163
Y27	VSS57	VSS164
U27	VSS58	VSS165
T27	VSS59	VSS166
R27	VSS60	VSS167
P27	VSS61	VSS168
N27	VSS62	VSS169
M27	VSS63	VSS170
G27	VSS64	VSS171
E27	VSS65	VSS172
C27	VSS66	VSS173
B27	VSS67	VSS174
AL26	VSS68	VSS175
AH26	VSS69	VSS176
W26	VSS70	VSS177
U26	VSS71	VSS178
AN25	VSS72	VSS179
AK25	VSS73	VSS180
AG25	VSS74	VSS181
AE25	VSS75	VSS182
J25	VSS76	VSS183
G25	VSS77	VSS184
A25	VSS78	VSS185
H23	VSS79	
F23	VSS80	
B23	VSS81	
AM22	VSS82	
AJ22	VSS83	
AF22	VSS84	
G22	VSS85	
F22	VSS86	
J21	VSS87	
H21	VSS88	
F21	VSS89	
AM20	VSS90	
AK20	VSS91	
AH20	VSS92	
AF20	VSS93	
D20	VSS94	
W19	VSS95	
R19	VSS96	
AM18	VSS97	
AH18	VSS98	
AF18	VSS99	
U18	VSS100	
H18	VSS101	
D18	VSS102	
AK17	VSS103	
V17	VSS104	
T17	VSS105	
F17	VSS106	
B17	VSS107	
AH16	VSS108	
U16	VSS109	
	VSS110	

VSS

U18G

>W33	NC1	NC61	W30
>AM33	NC2	NC62	Y6
>AL33	NC3	NC63	AL1
>C33	NC4	NC64	Y5
>B33	NC5	NC65	Y10
>AN32	NC6	NC66	W10
>A32	NC7	NC67	W25
>AM31	NC8	NC68	W24
>W28	NC9	NC69	V10
>V27	NC10	NC70	U10
>W29	NC11	NC71	K18
>J24	NC12	NC72	
>H24	NC13		
>W32	NC14		
>G24	NC15		
>F24	NC16		
>E24	NC17		
>D24	NC18		
>K33	NC19		
>A31	NC20		
>E21	NC21		
>C23	NC22		
>AN19	NC23		
>AM19	NC24		
>AL19	NC25		
>J19	NC26		
>A19	NC27		
>AH19	NC28		
>AN3	NC29		
>Y3	NC30		
>H19	NC31		
>G19	NC32		
>F19	NC33		
>E19	NC34		
>D19	NC35		
>C19	NC36		
>B19	NC37		
>A19	NC38		
>Y8	NC40		
>G16	NC41	MCH_RSVD26	Y25
>F16	NC42	MCH_RSVD27	Y24
>E16	NC43	MCH_RSVD28	AB22
>D16	NC44	MCH_RSVD29	AB21
>C16	NC45	MCH_RSVD30	AB19
>B16	NC46	MCH_RSVD31	AB18
>AN2	NC47	MCH_RSVD32	AB14
>A16	NC48	MCH_RSVD33	AA12
>Y7	NC49	MCH_RSVD34	W24
>AM4	NC50	MCH_RSVD35	AB24
>AF4	NC51	MCH_RSVD36	AB20
>AD4	NC52	MCH_RSVD37	AB18
>V4	NC53	MCH_RSVD38	AB15
>AK4	NC54	MCH_RSVD39	AB13
>W31	NC55	MCH_RSVD40	AB12
>A14	NC56	MCH_RSVD41	AB17
>AH4	NC57	MCH_RSVD42	
>AG4	NC58		
>AE4	NC59		
>AM1	NC60		

NC

945GMS

945GMS

 Quanta Computer Inc. PROJECT : FL1		Rev	1A
		Size	1A
Date: Saturday, June 07, 2008		Sheet 11 of 34	
Document Number		945GMS_GND	

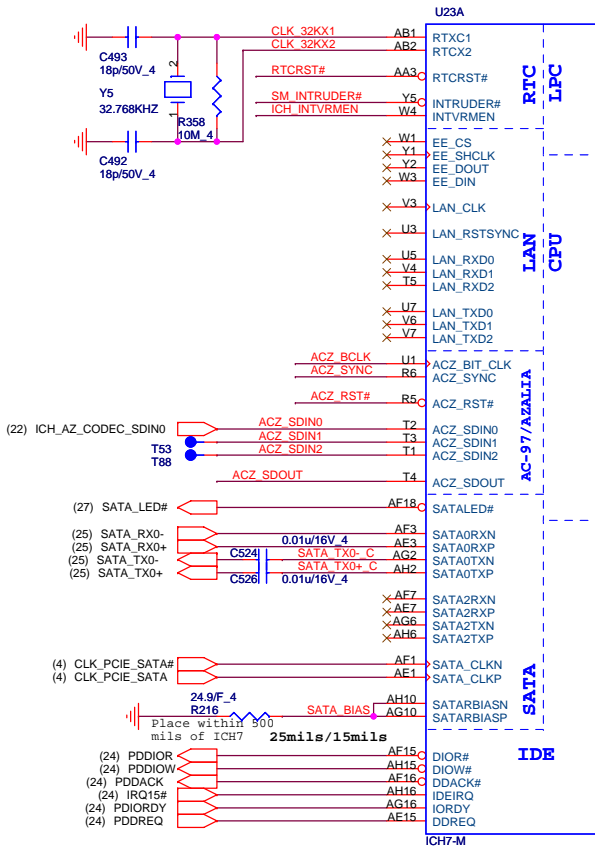

Pull-UP

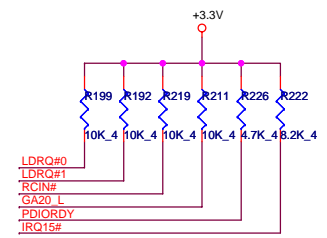

RTC

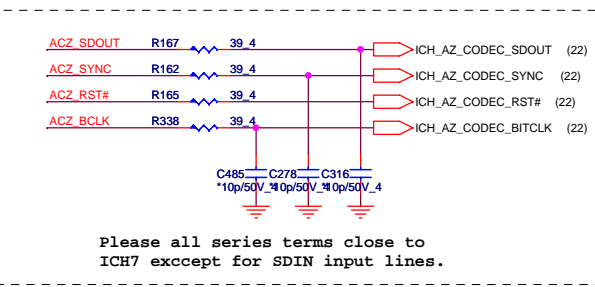
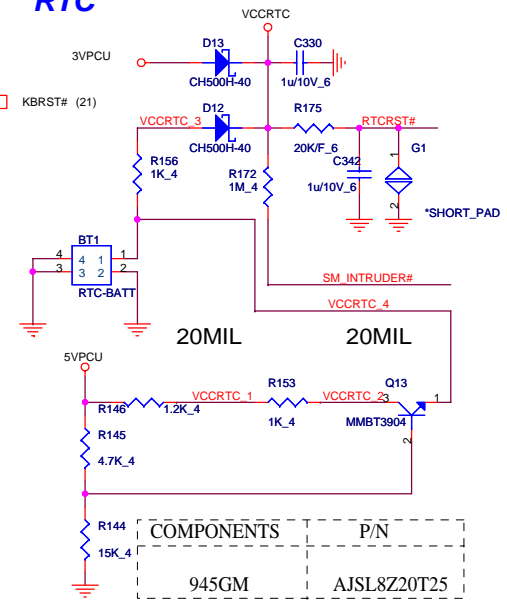

	INTVRMEN
Enable (default)	1
Disable	0

ICH7 internal VR enable strap

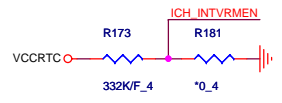

PCIE distribution

PCIE1	Ethernet Controller
PCIE2	New Card
PCIE3	MINI PCI-E Card
PCIE4	NC
PCIE5	NC
PCIE6	NC

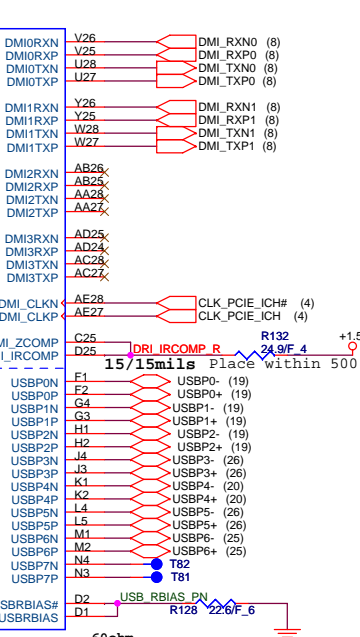
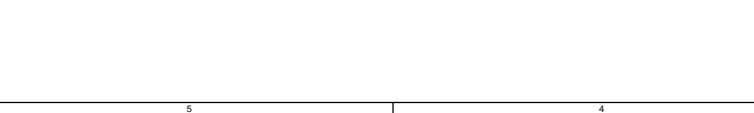
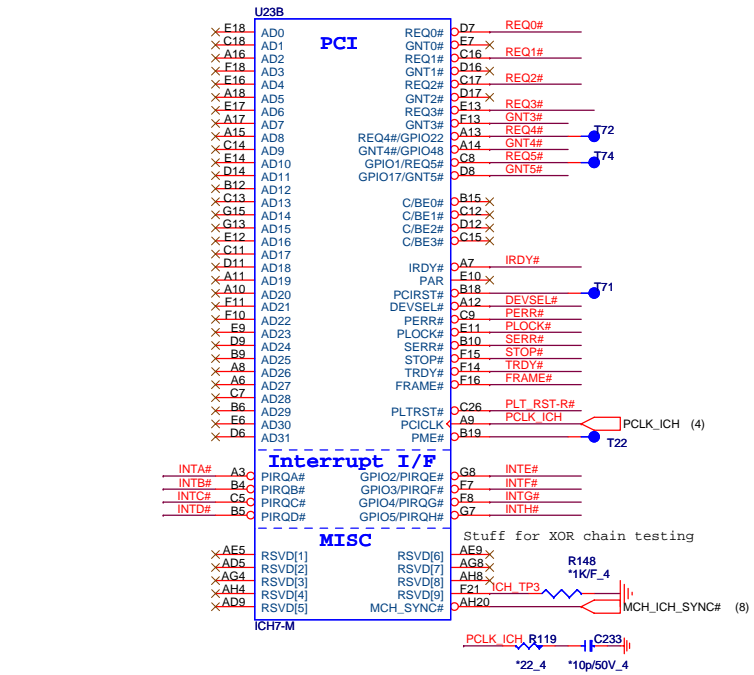

60ohm Place within 500 mils of ICH7

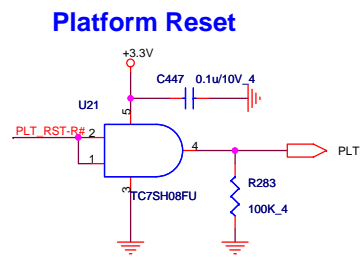
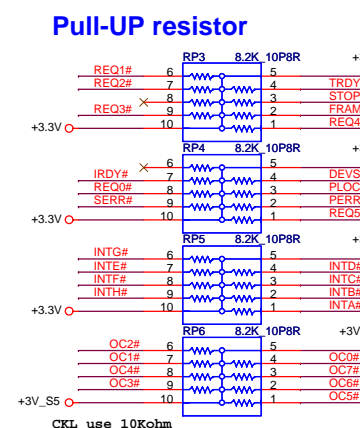

USB distribution

USB0	USB Port 1
USB1	USB Port 2
USB2	Camera
USB3	Bluetooth
USB4	Card Reader
USB5	MINI PCI-E CARD
USB6	New Card
USB7	Reserve

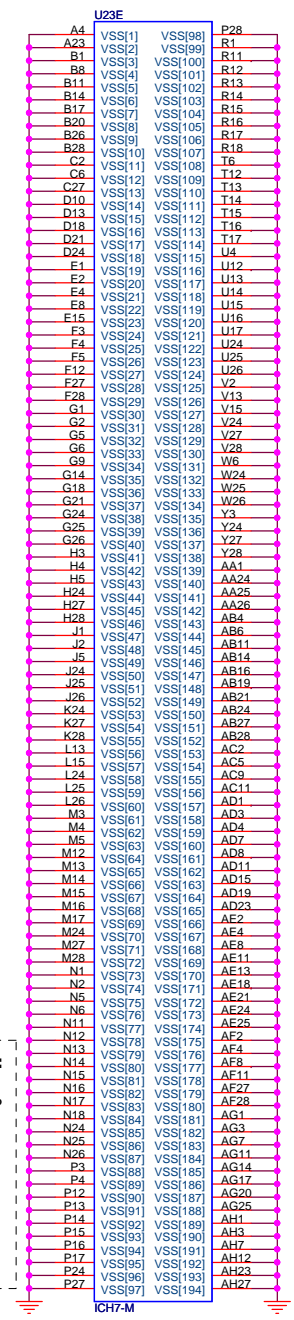
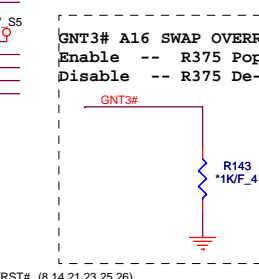
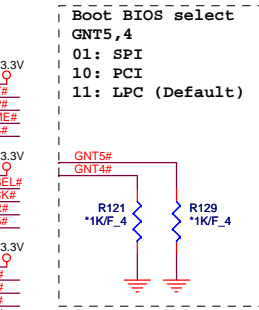

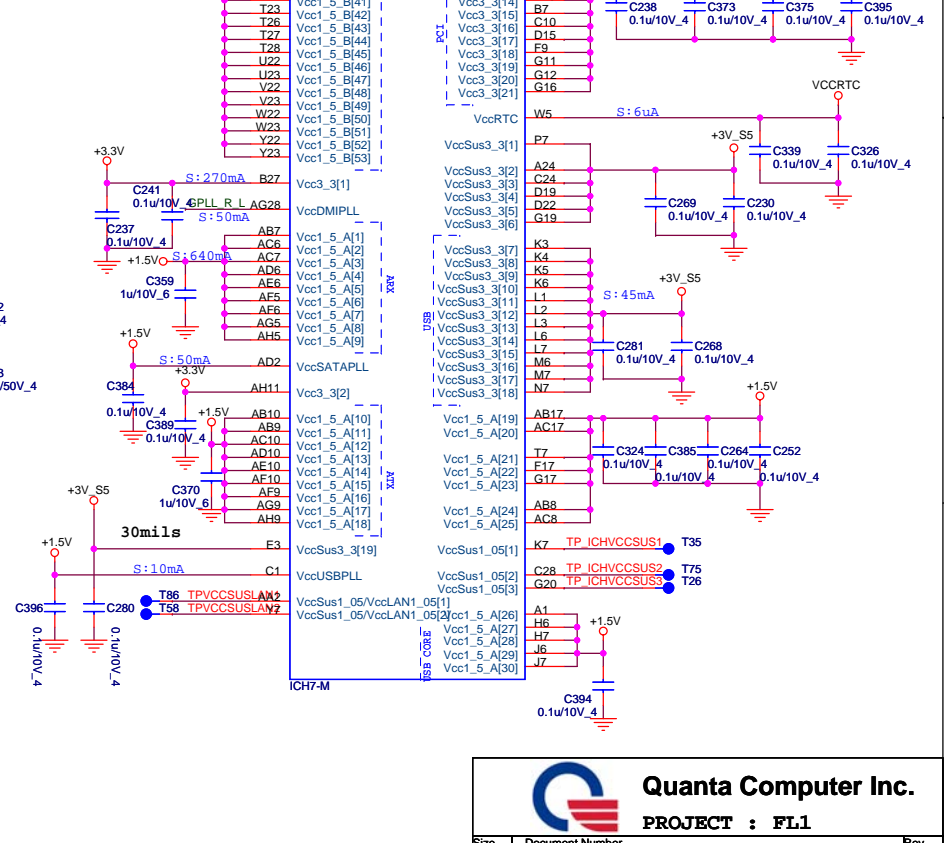
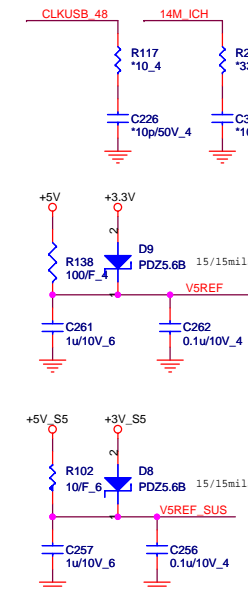
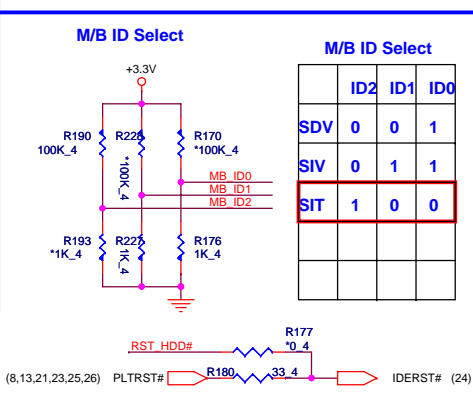
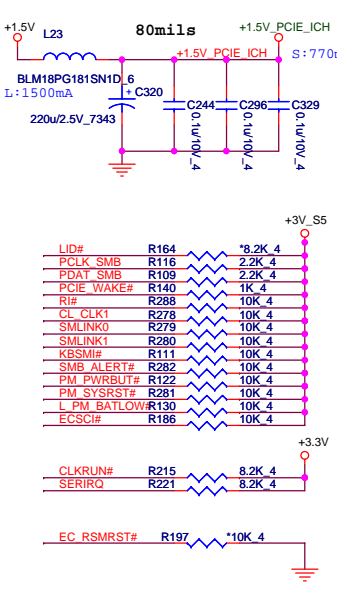
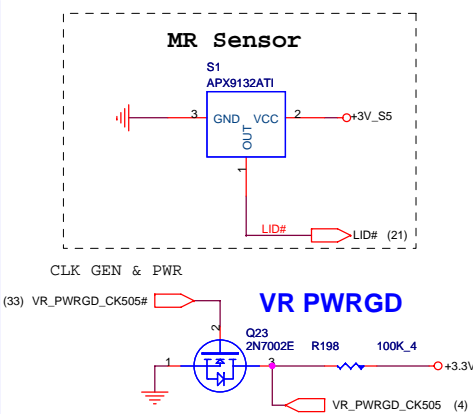
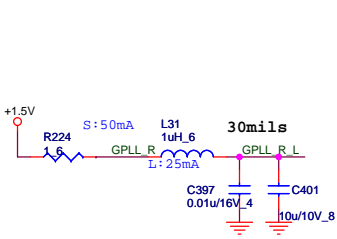
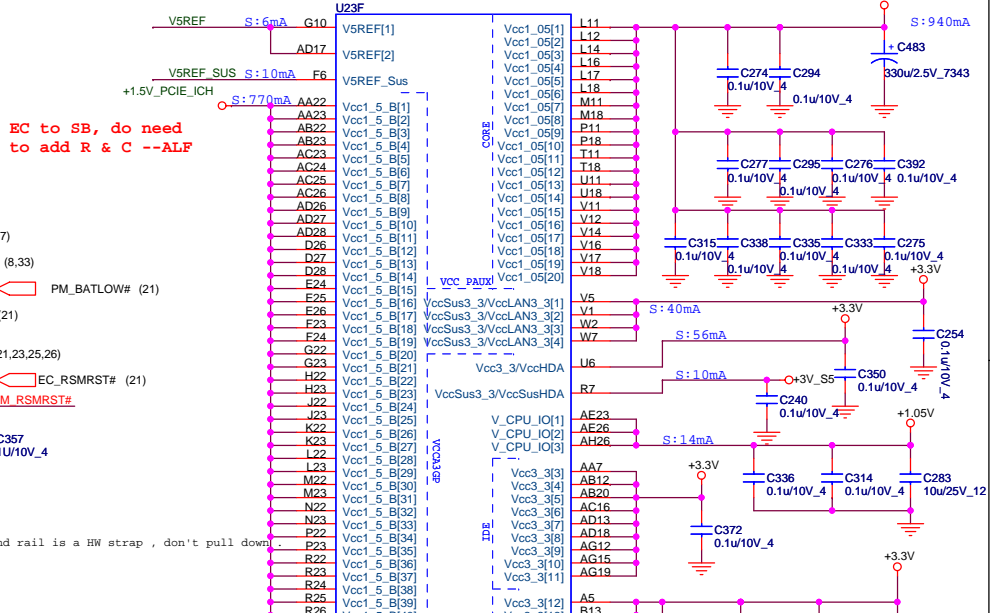
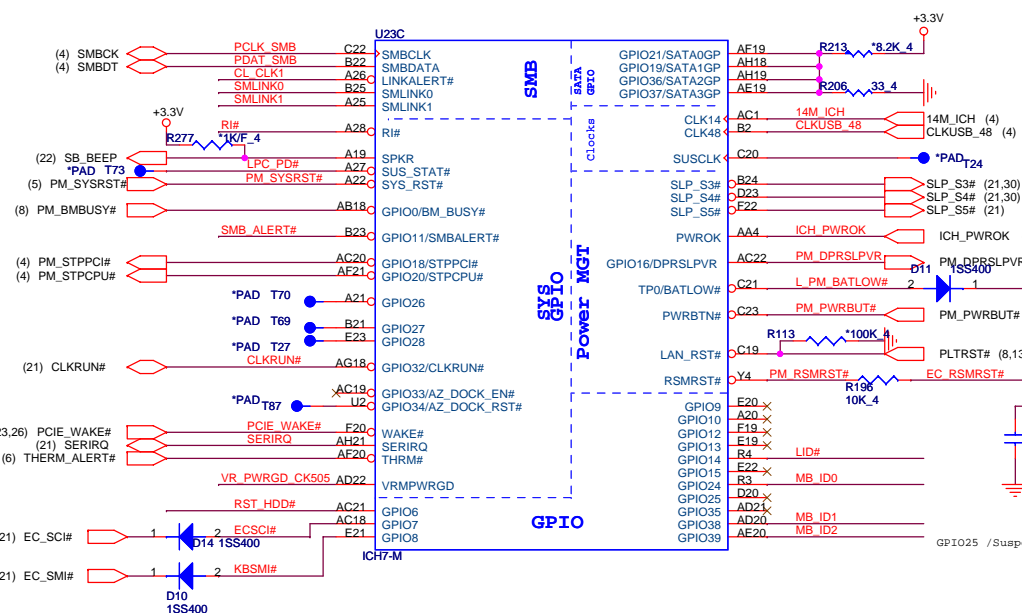

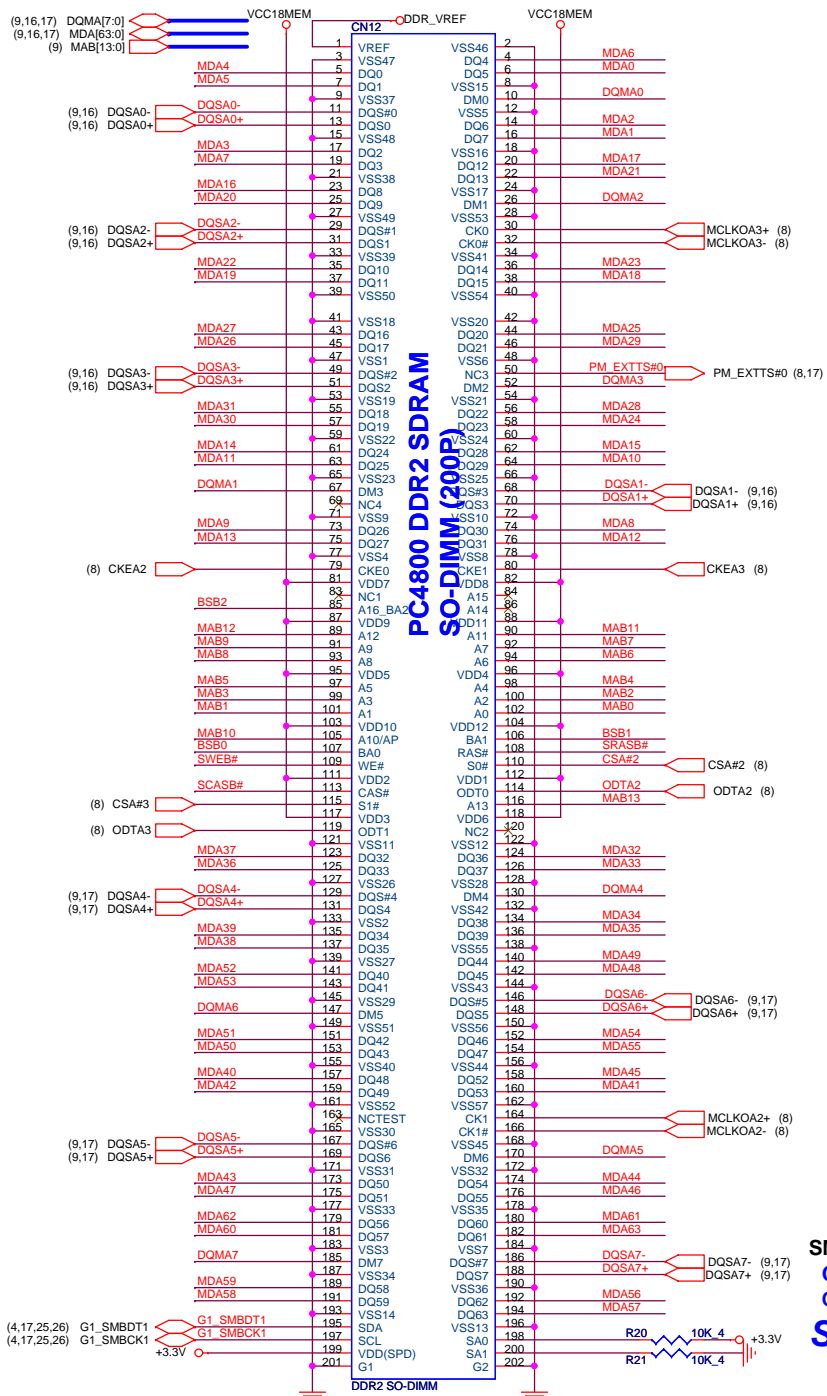

Close to SO-DIMM

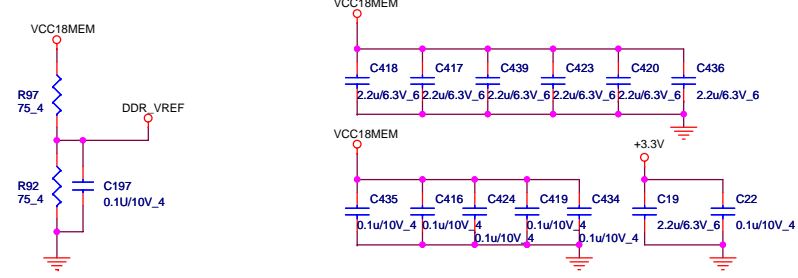

Termination resistor

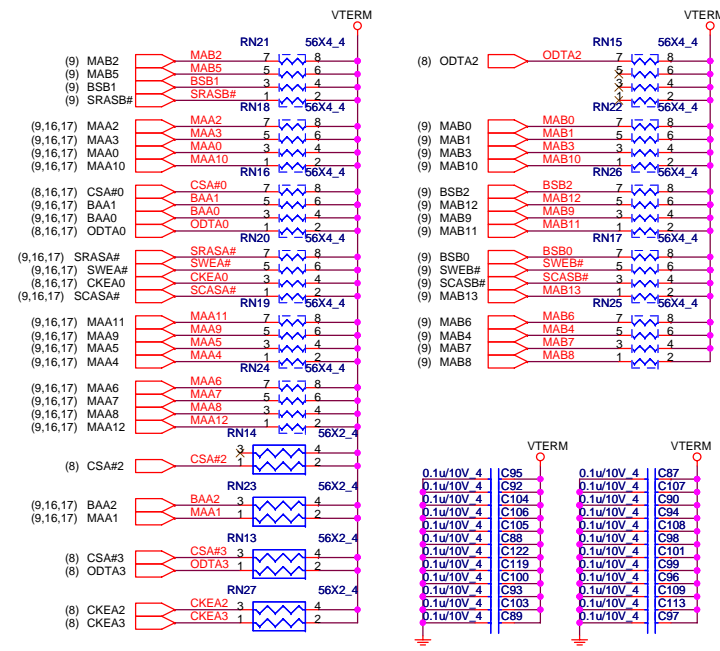

SMbus address A1
CLOCK 1,2
CKE 2,3
Standard Type H: 5.2mm

Quanta Computer Inc.
PROJECT : FL1

Size Document Number **DDR2 SO-DIMM(200P)** Rev 1A

Date: Saturday, June 07, 2008 Sheet 15 of 34

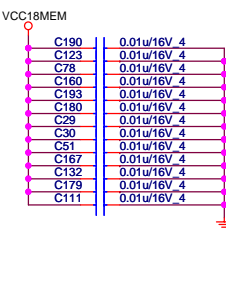
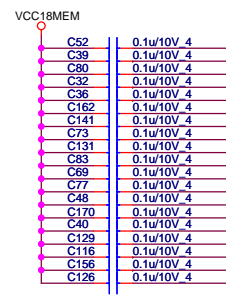
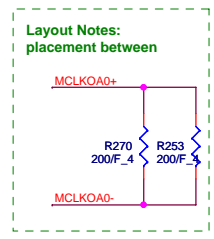
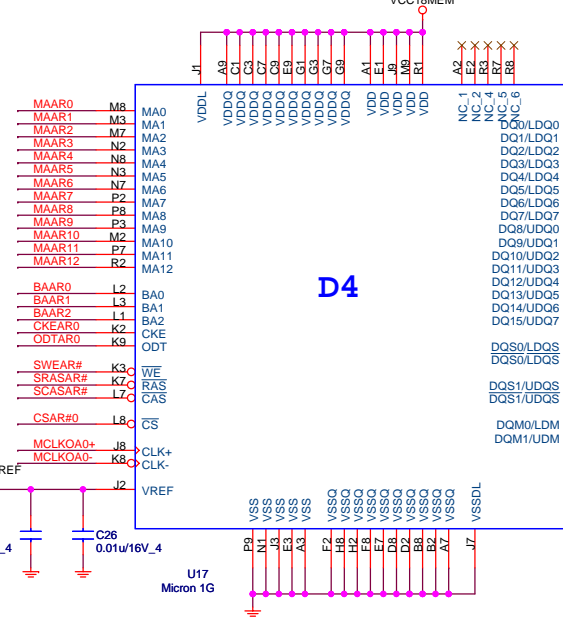
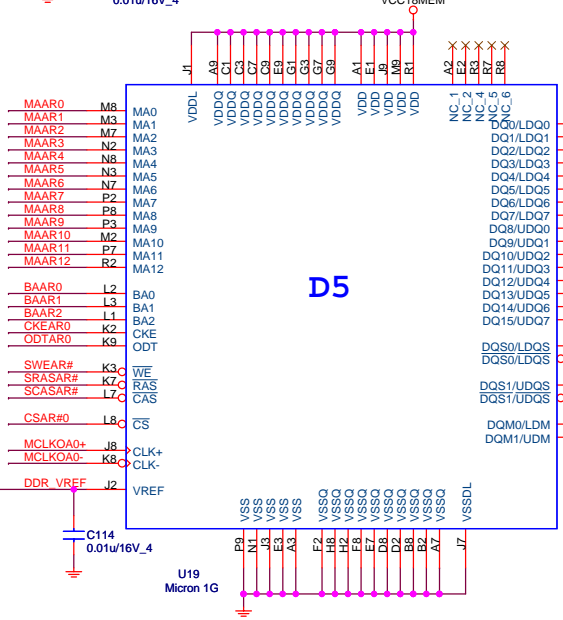
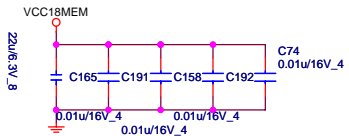
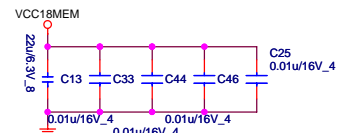
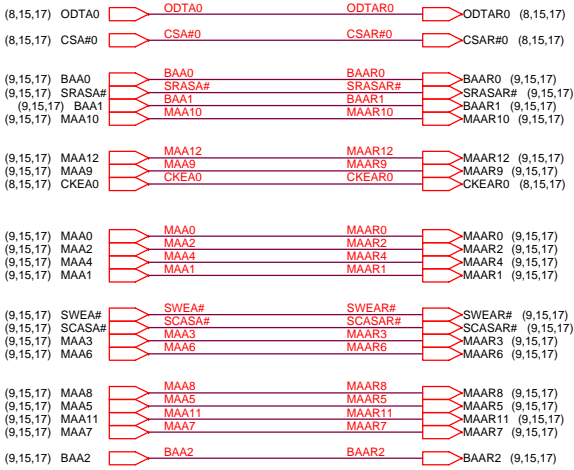
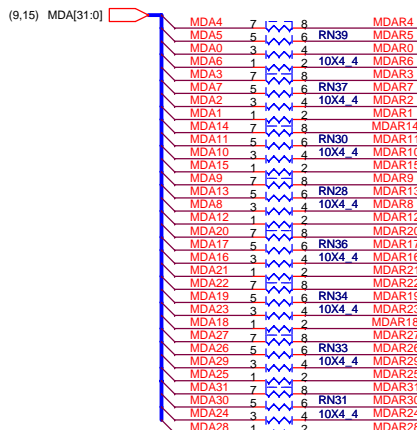
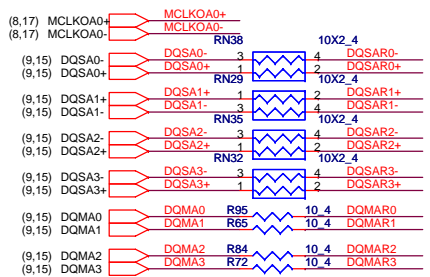

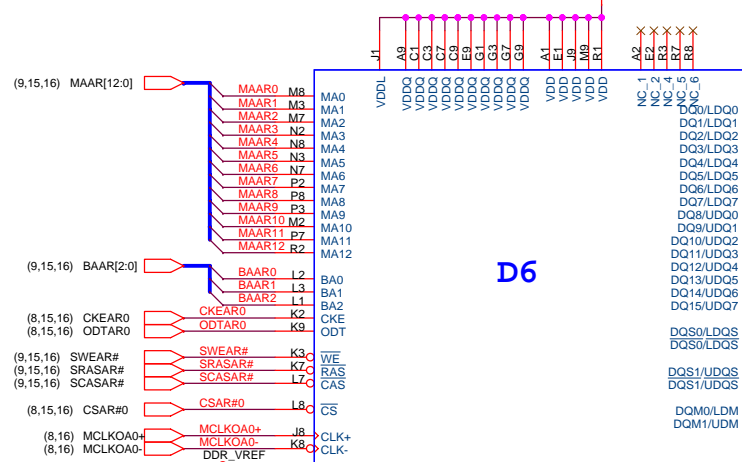
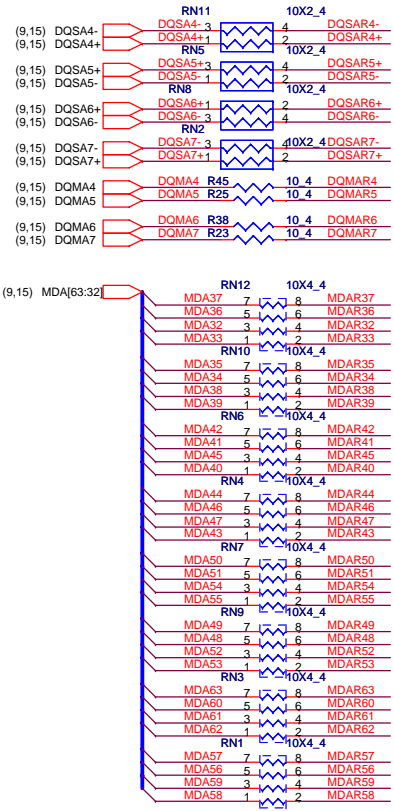
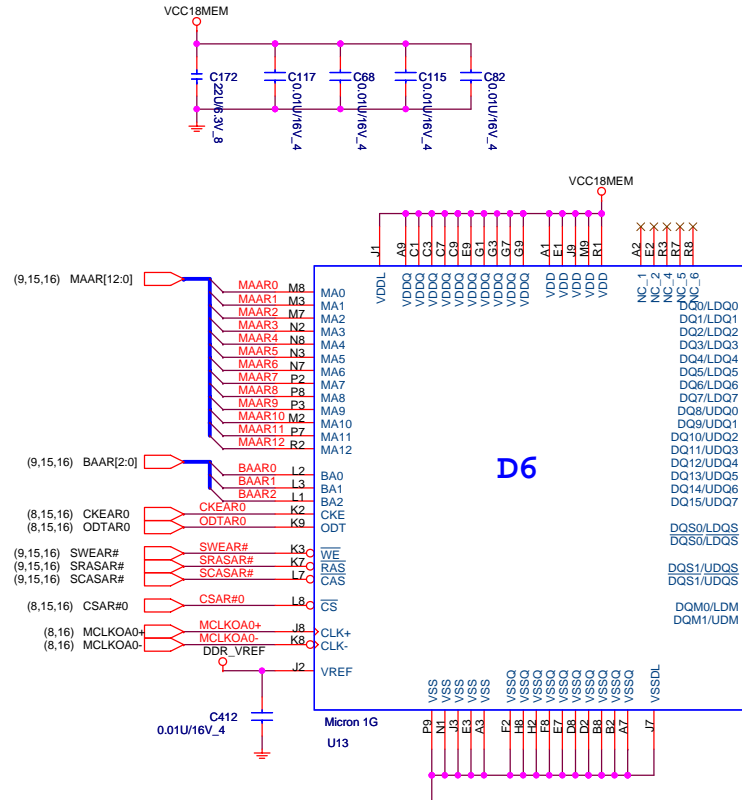
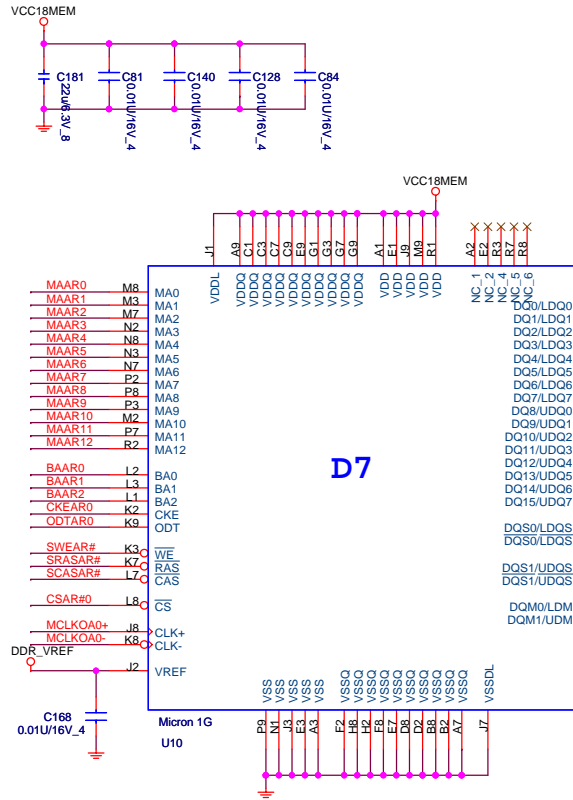

Reserve for On-Board RAM

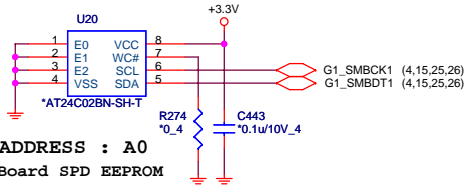
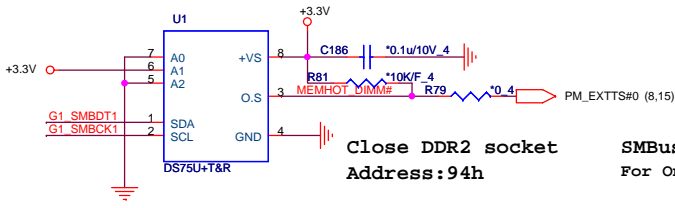

Quanta Computer Inc.
PROJECT : FL1

Size	Document Number	Rev
	DDR2_MODULE_RANK2	1A
Date:	Saturday, June 07, 2008	Sheet 17 of 34

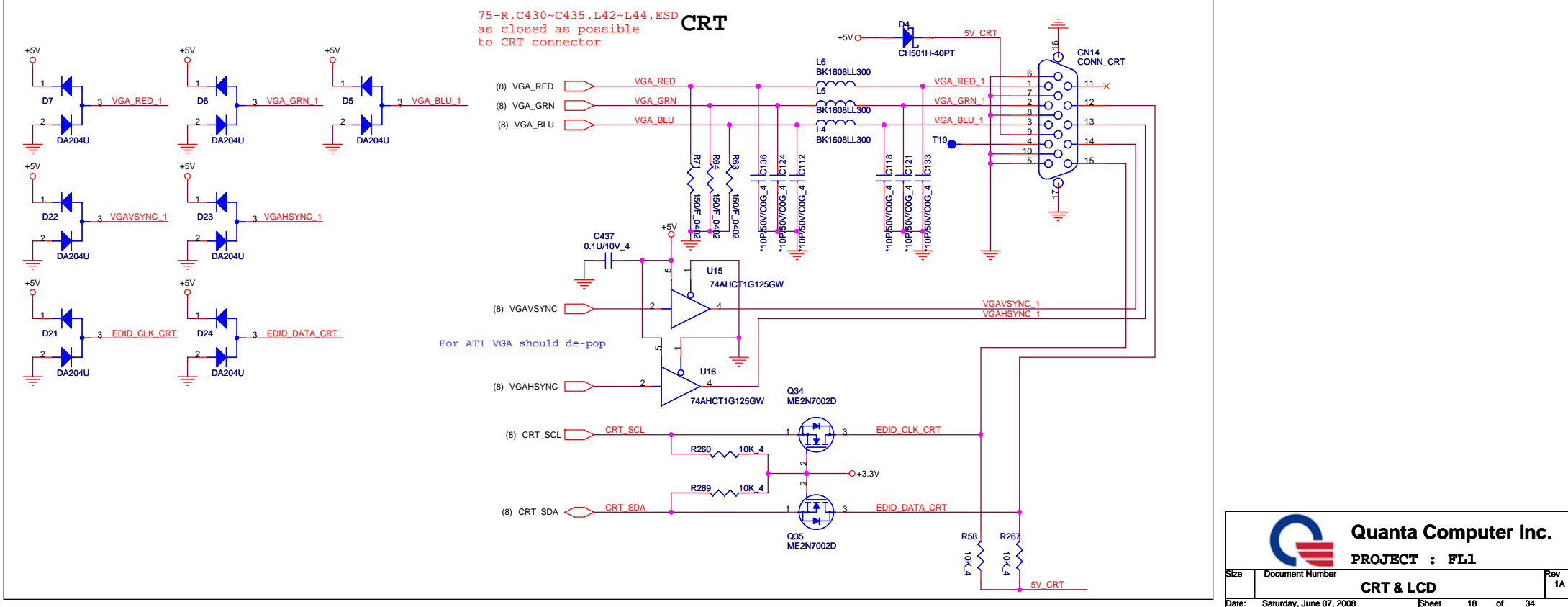
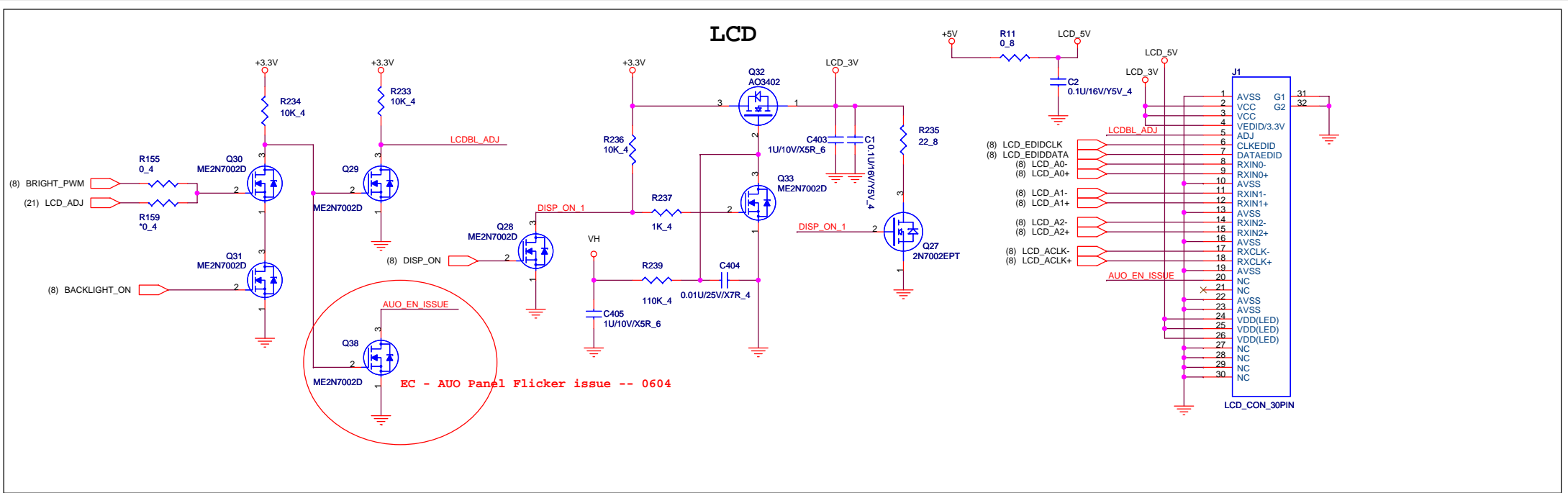

FAN

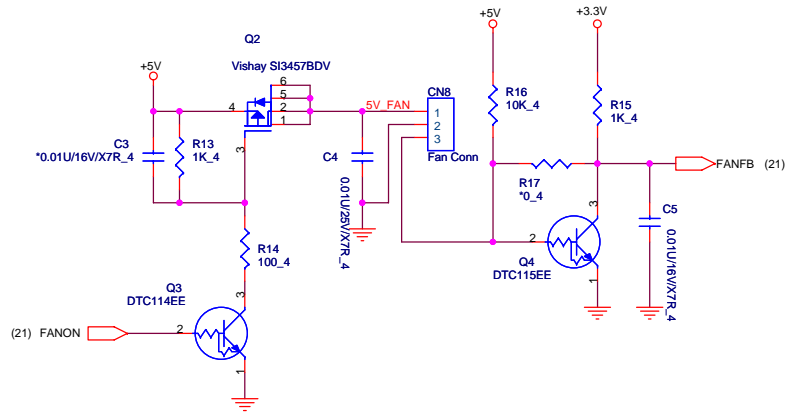

CAMERA

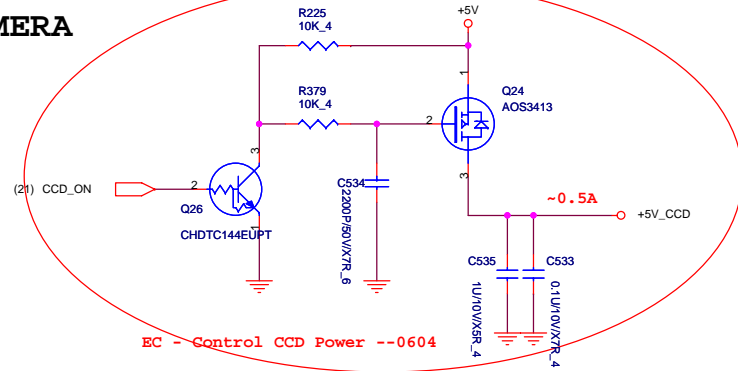

EC - Control CCD Power --0604

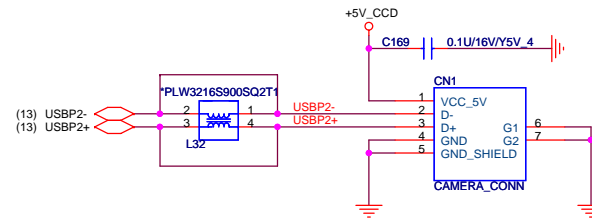

USB X 2 PORTS

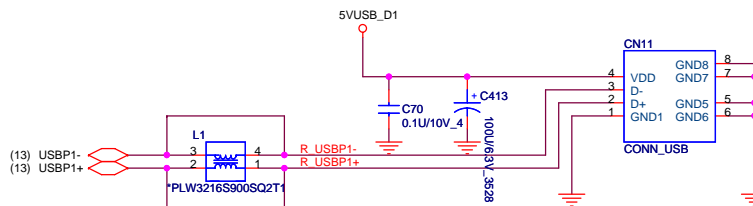
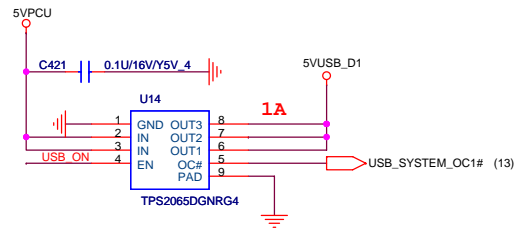
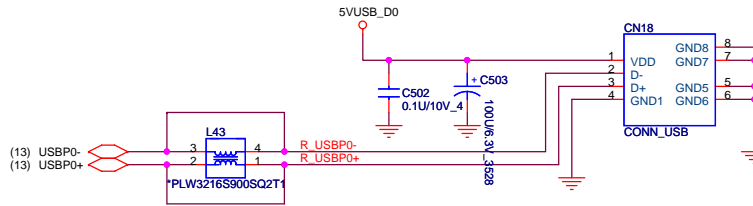
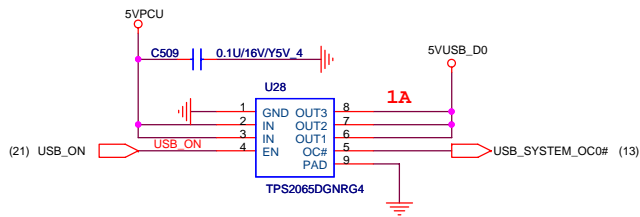

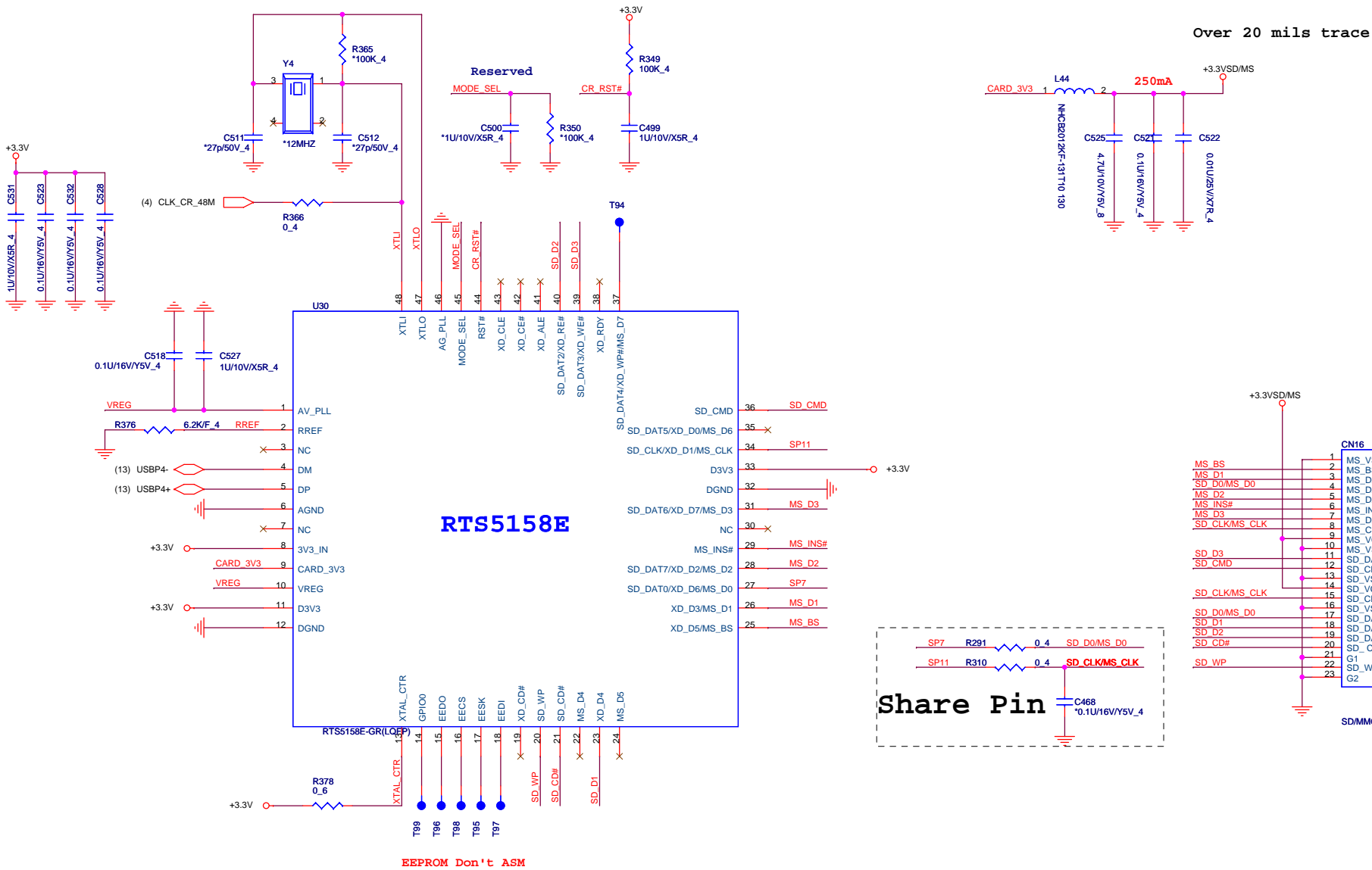

Over 20 mils trace

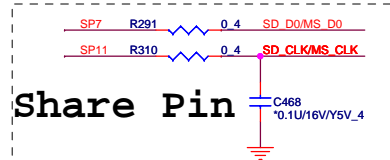

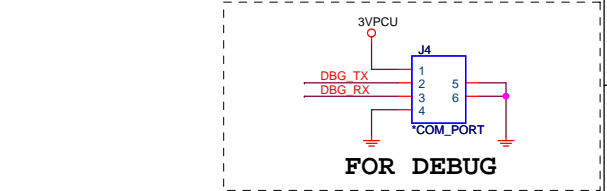
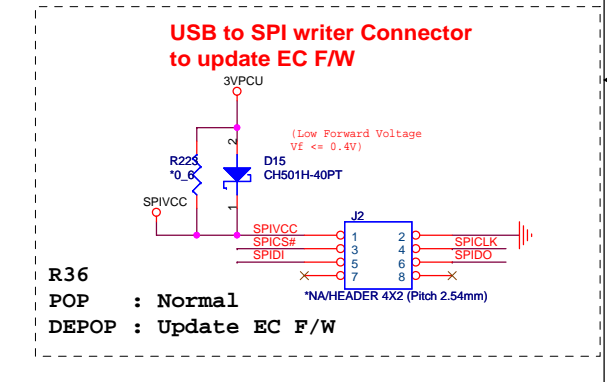
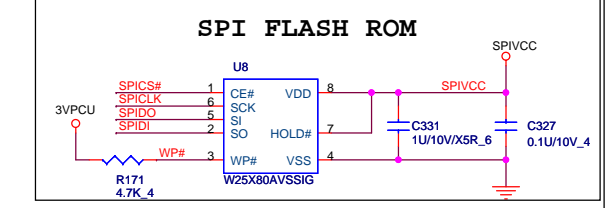
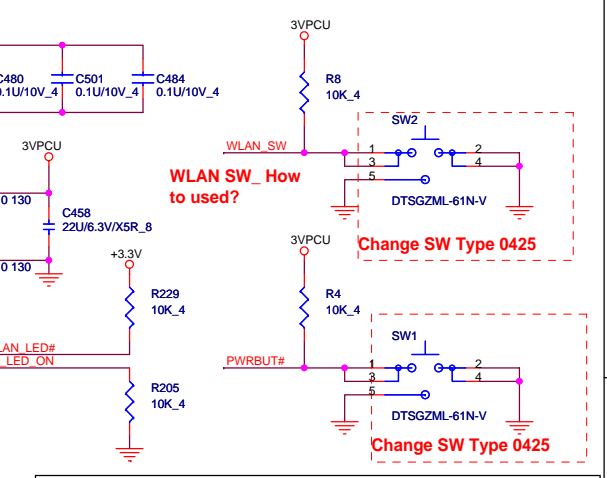
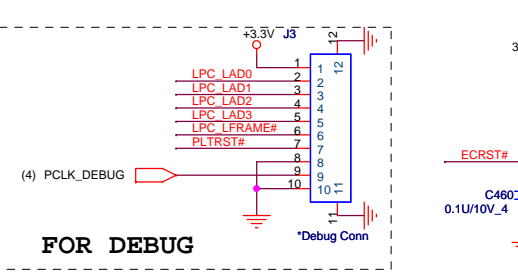
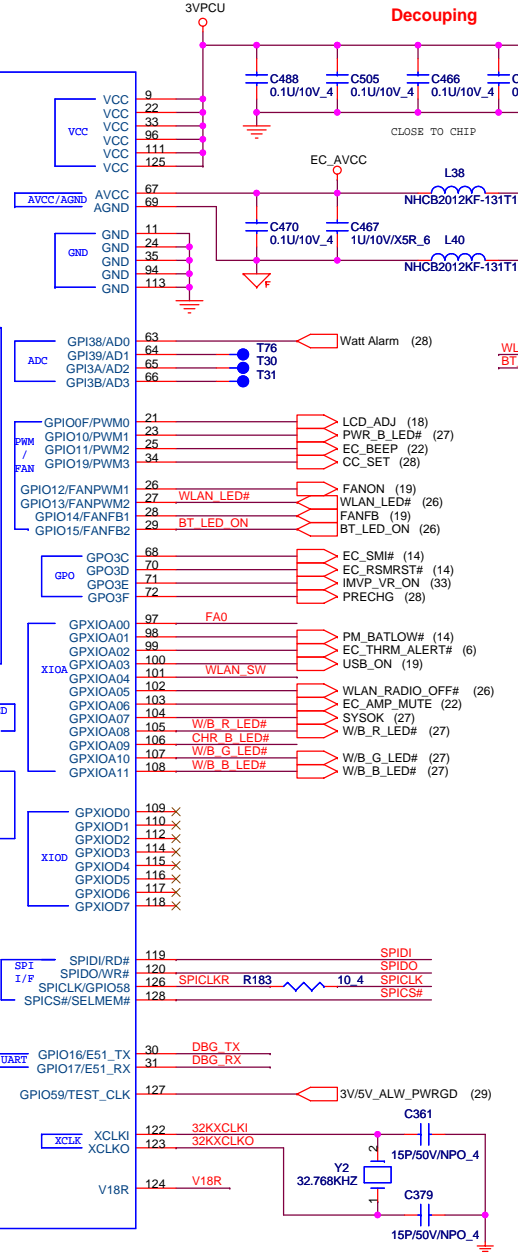
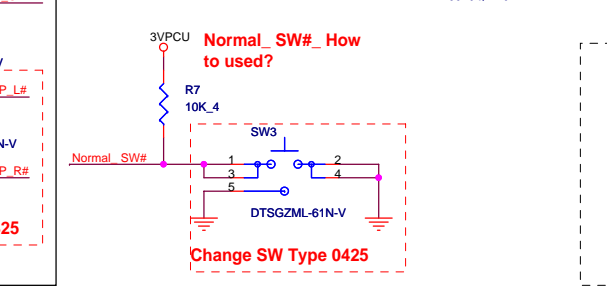
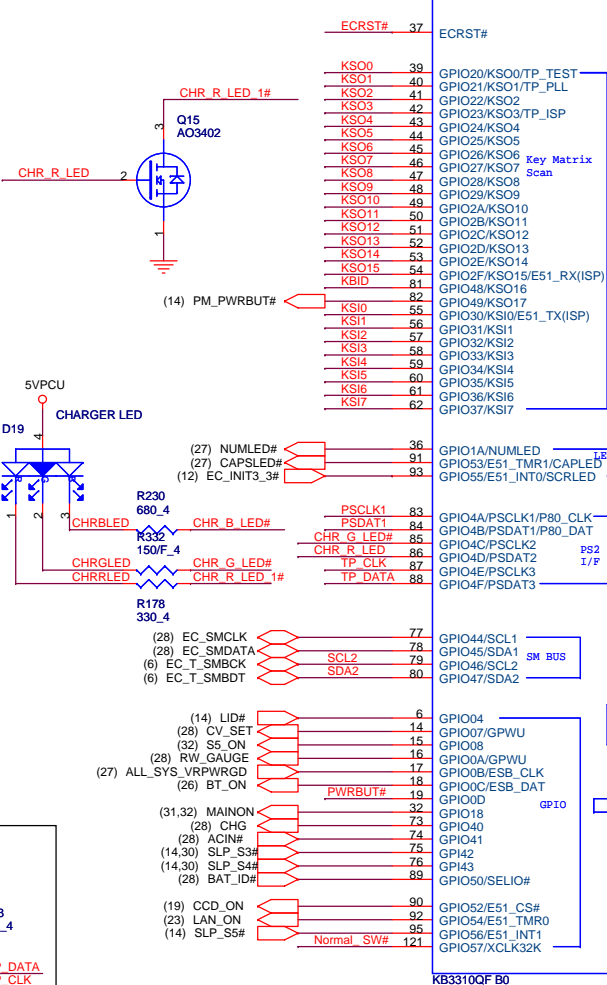
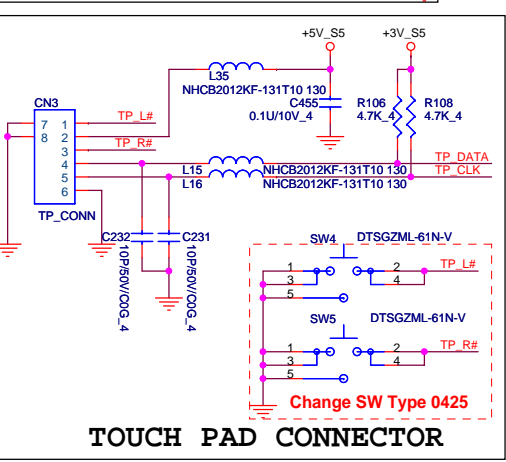
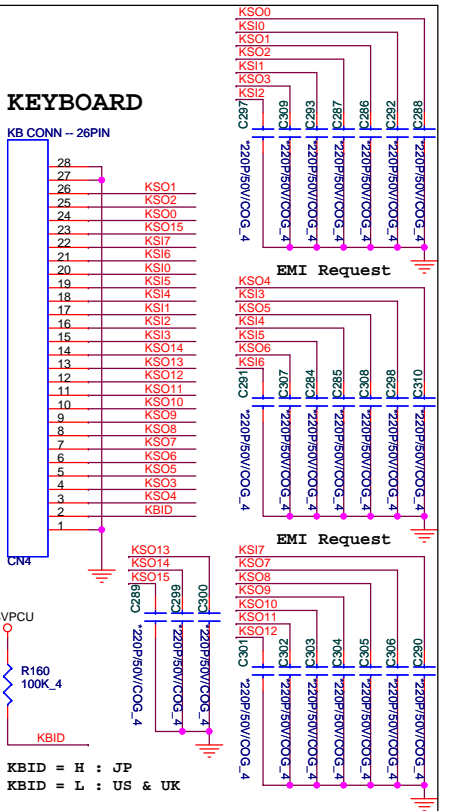
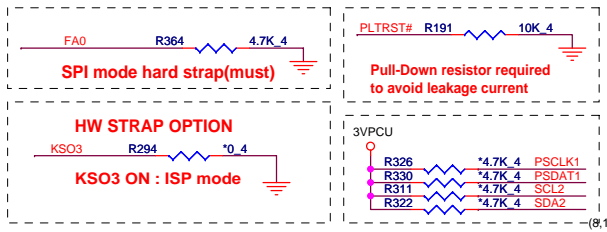

FOR DEBUG
V18R connections: C515 4.7U/10V/V5V_8, C510 0.1U/10V_4.

Quanta Computer Inc.
PROJECT : FL1

EC KB3310

Size: Document Number: Rev 1A

Date: Saturday, June 07, 2008 Sheet 21 of 34

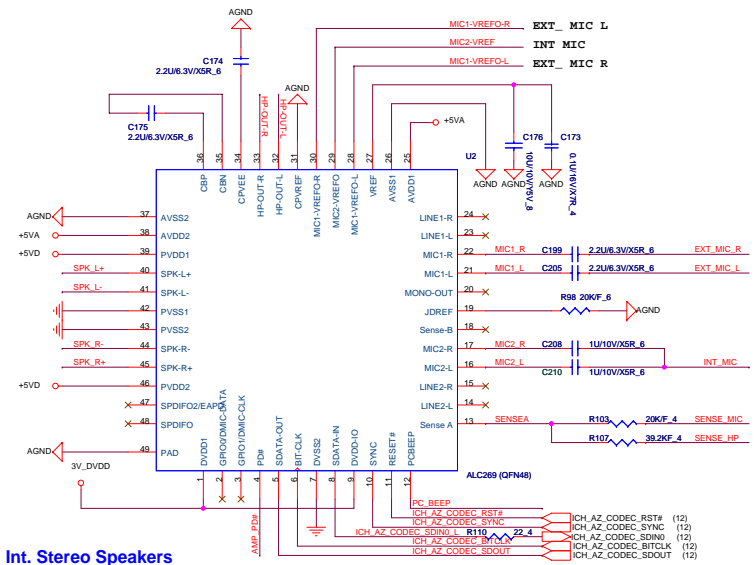

Int. Stereo Speakers
5V / 4 Ohm / 1.5W

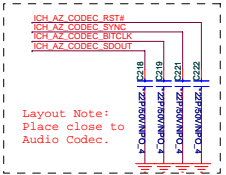
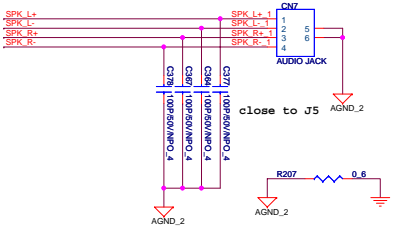

EC_AMP_MUTE	HP_PLUG	AMP_SHDN#
0	0	1
0	1	0
1	0	0
1	1	0

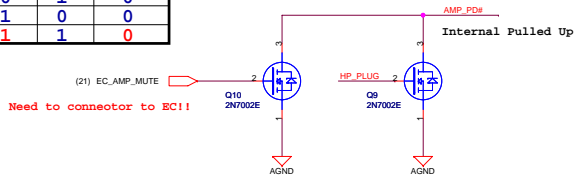

PC BEEP CONTROL

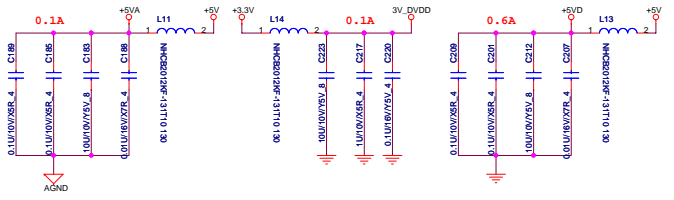
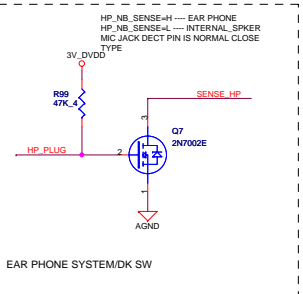
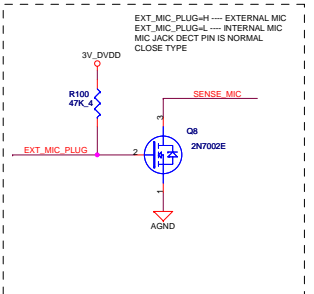
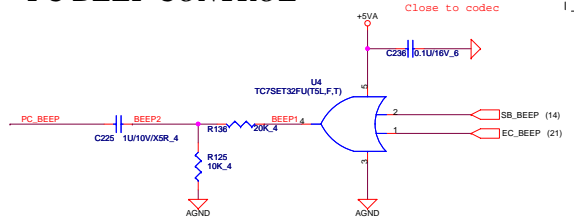

External Microphone Jack
Stereo MIC

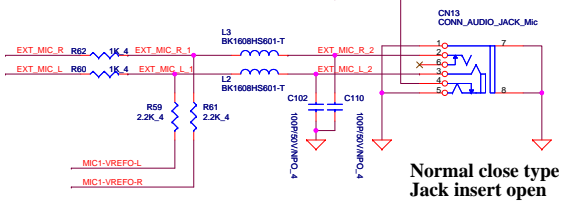

Normal close type Jack insert open

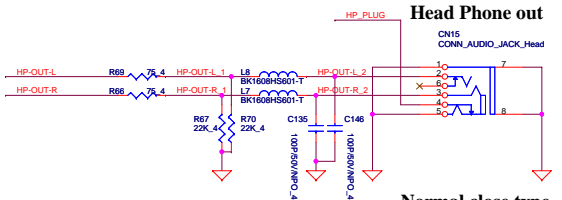

Head Phone out

Normal close type Jack insert open

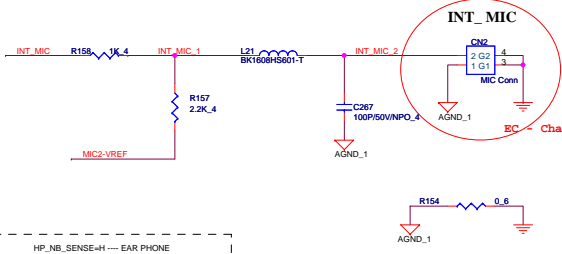

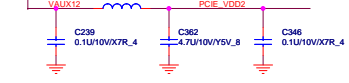
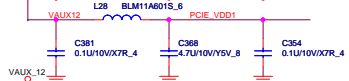
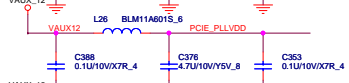
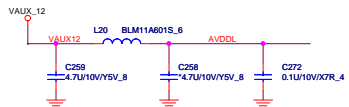
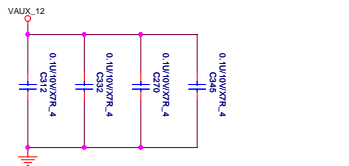

- (13) PCIE_LAN_RX1+
- (13) PCIE_LAN_RX1-
- (13) PCIE_LAN_TX1+
- (13) PCIE_LAN_TX1-

- (8,13,14,21,25,26) PLTRST#
- (4) CLK_PCIE_LAN#
- (6) CLK_PCIE_LAN#

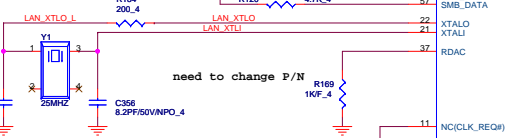

(4) LAN_CLK_REQ#

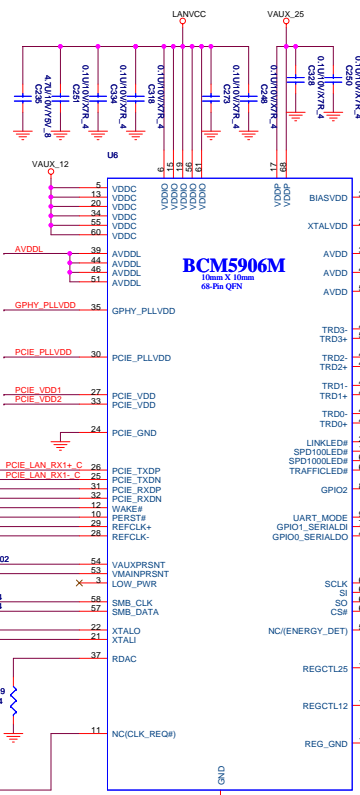
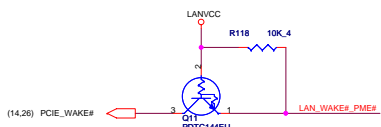

BCM5906M
10mm X 10mm
68-Pin QFN

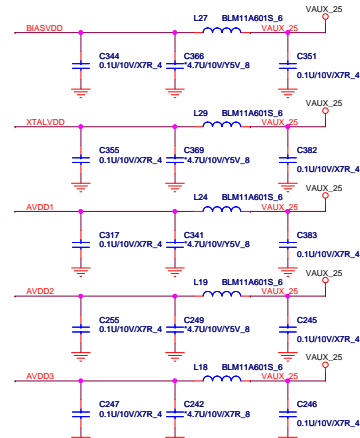

Placed near PHY chip

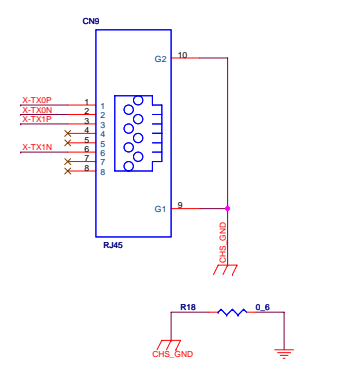
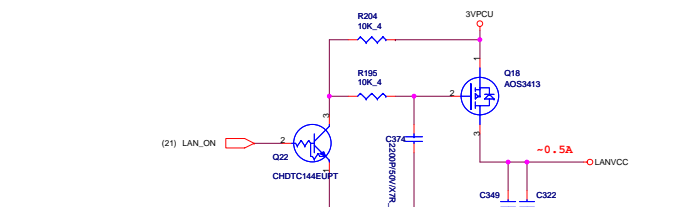
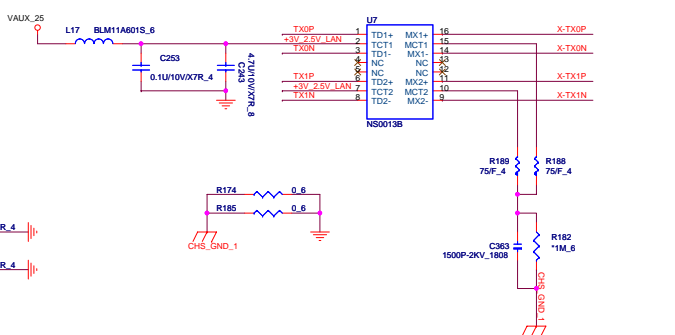
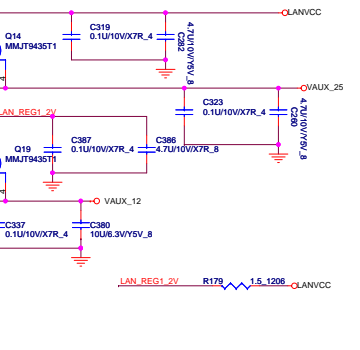
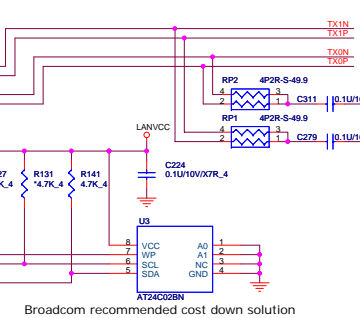

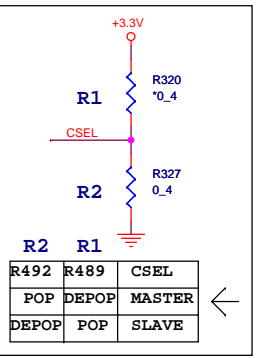
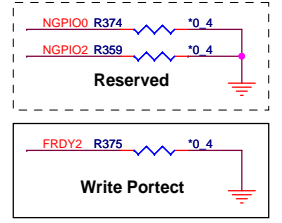
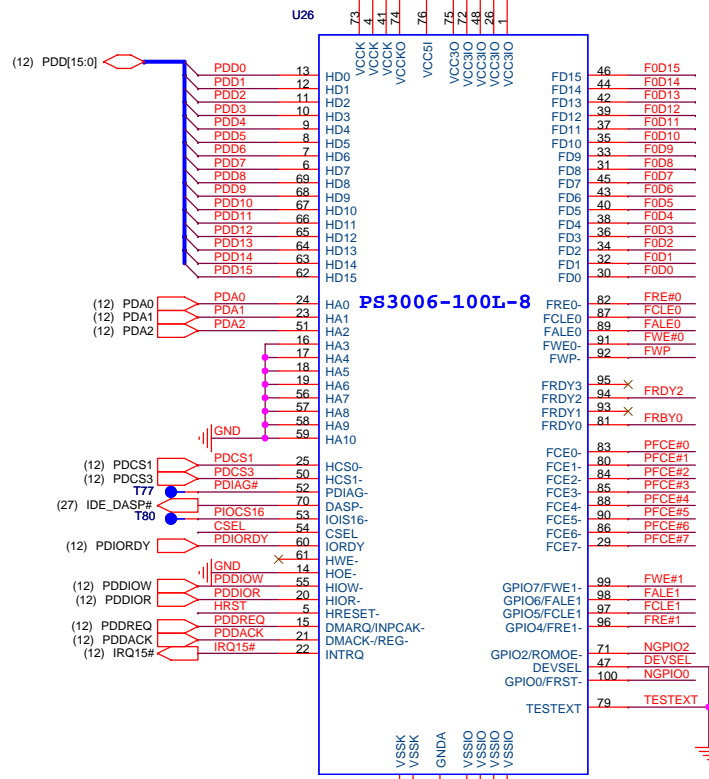
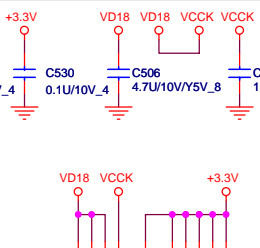
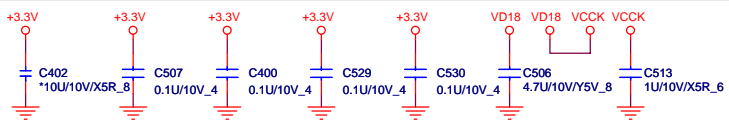

R2	R1	
R492	R489	CSEL
POP	DEPOP	MASTER
DEPOP	POP	SLAVE

1CE	RF0
2CE	RF0, RF1
4CE	RF0, RF1, RF2

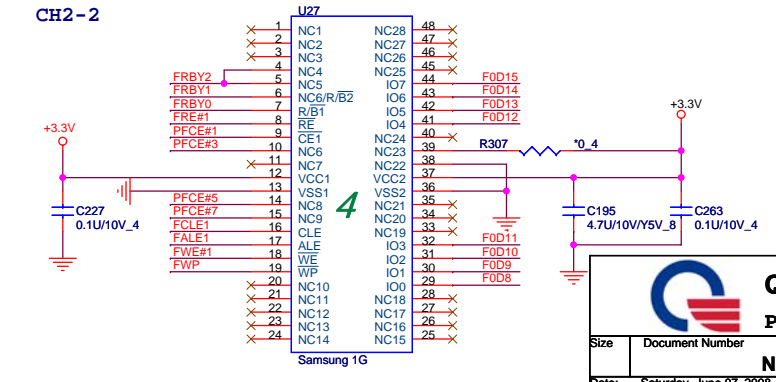
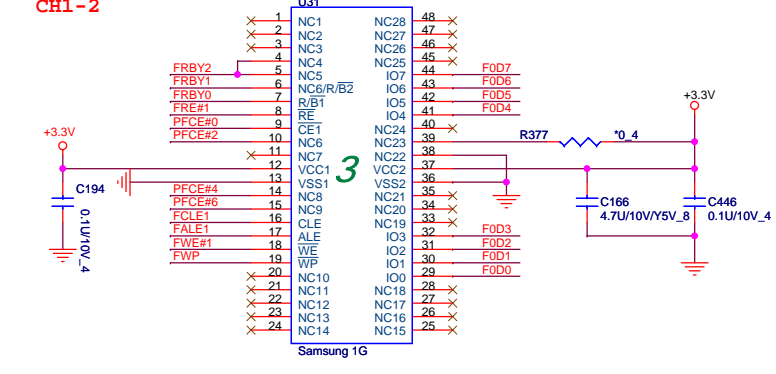
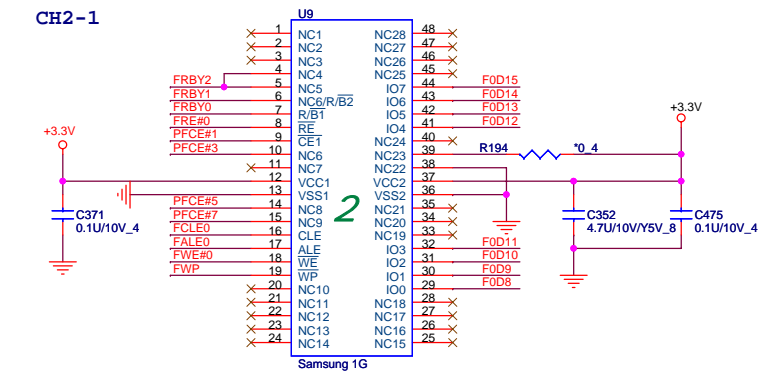
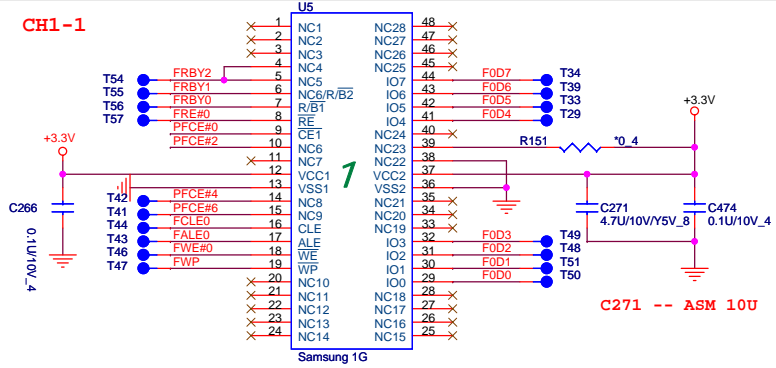

Quanta Computer Inc.

PROJECT : FL1

Date:	Saturday, June 07, 2008	Sheet	24 of 34
-------	-------------------------	-------	----------

NAND FLASH PS3006

Rev 1A

NEW CARD

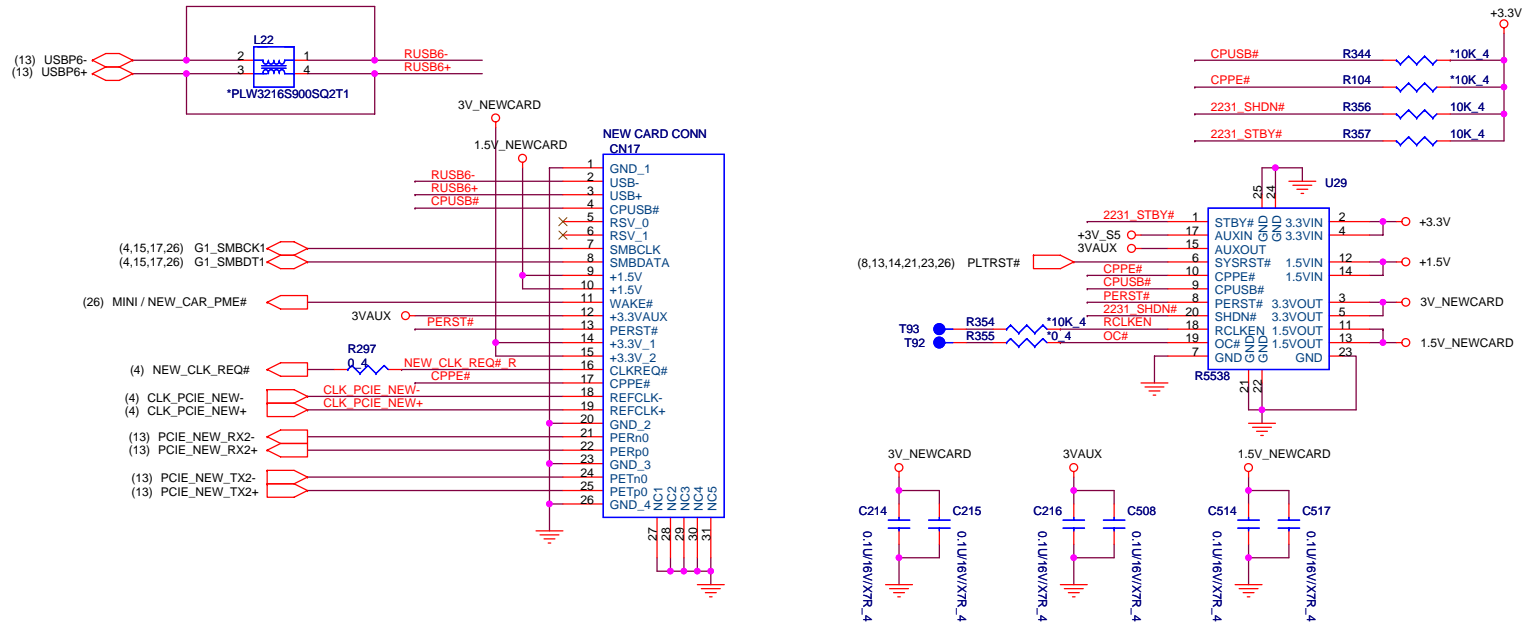

SATA CONNECTOR

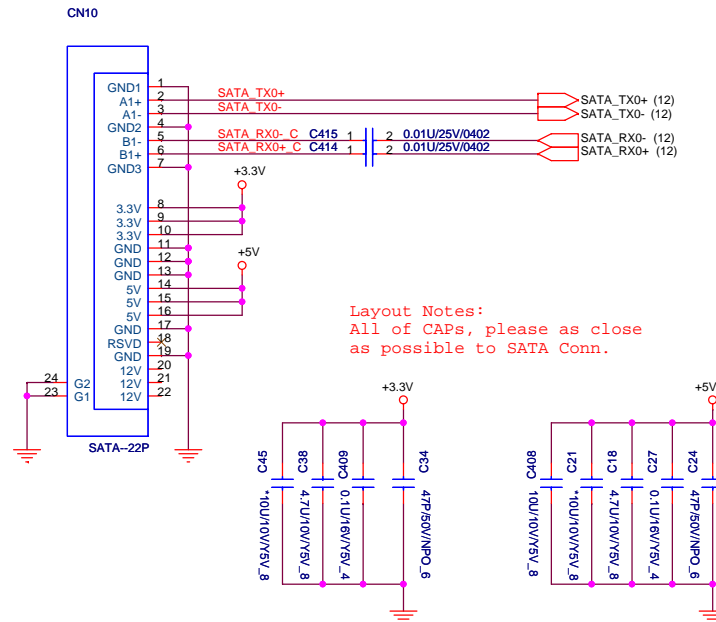

MiniCard WLAN connector

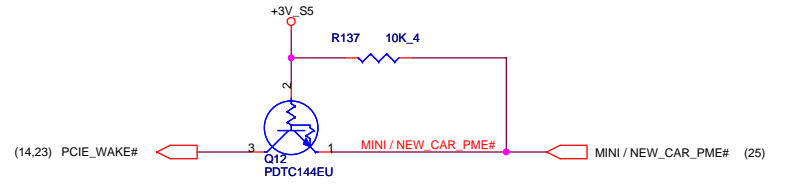
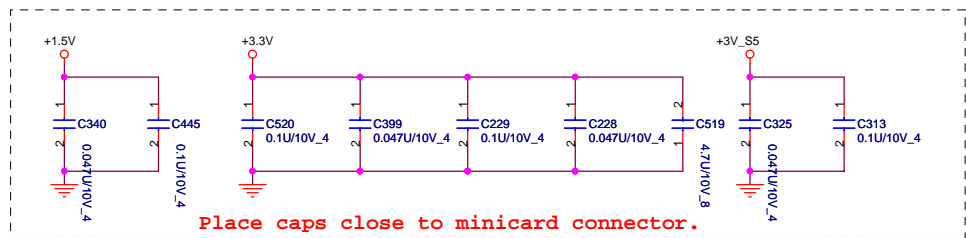
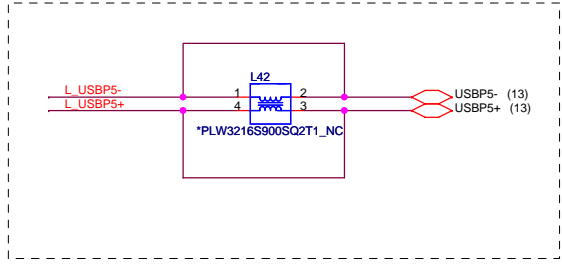
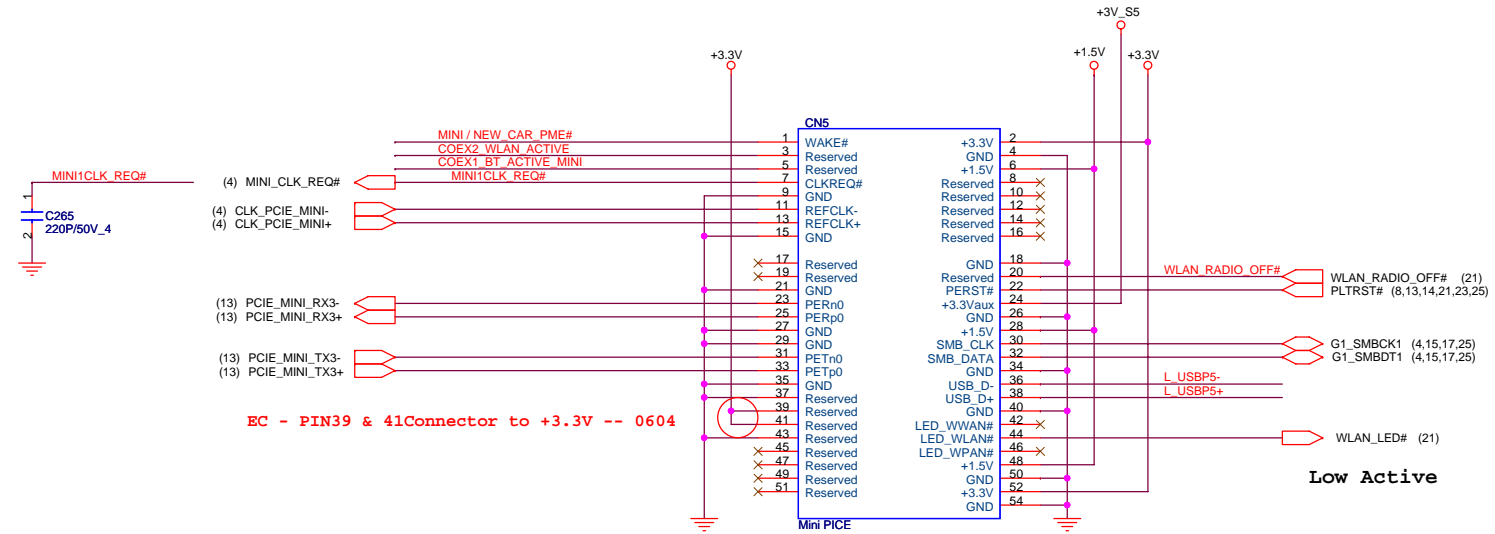

Bluetooth

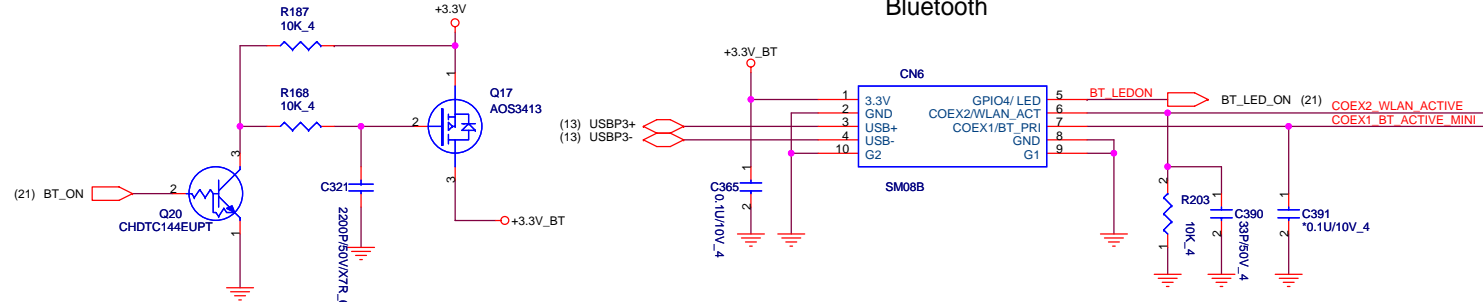

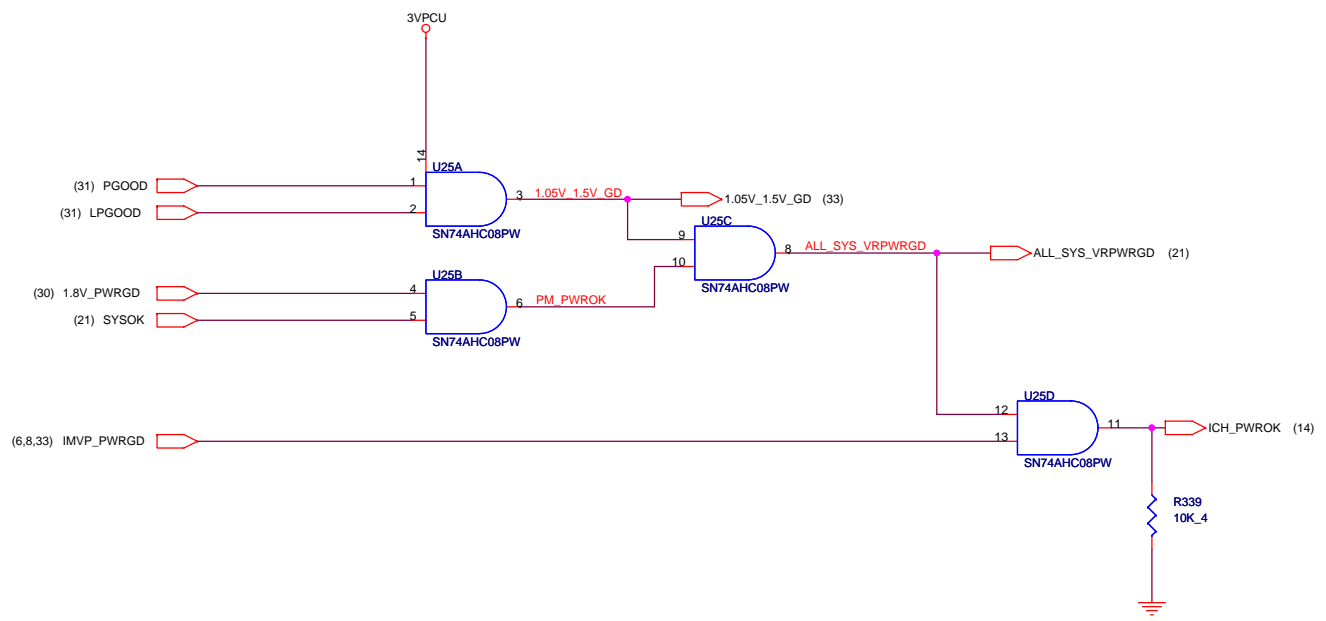

SATA/PATA LED

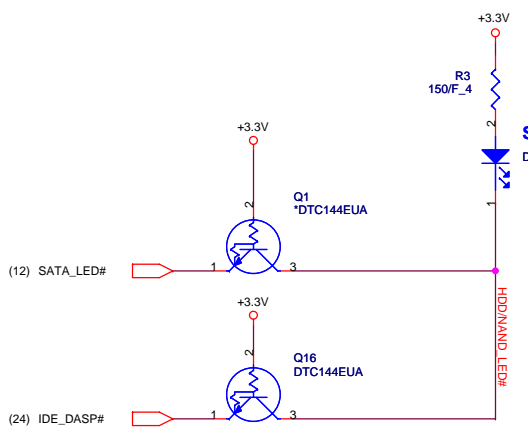

WLAN & BlueTooth LED

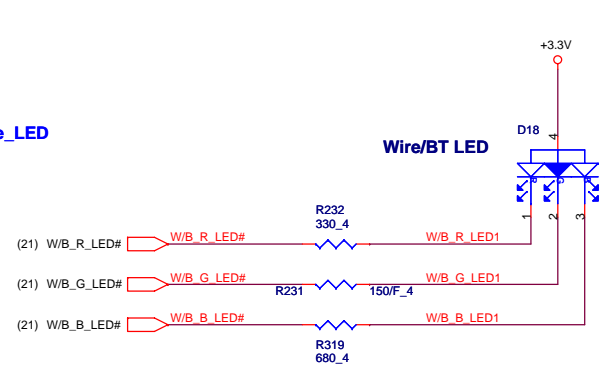

Number & CAPS Lock LED

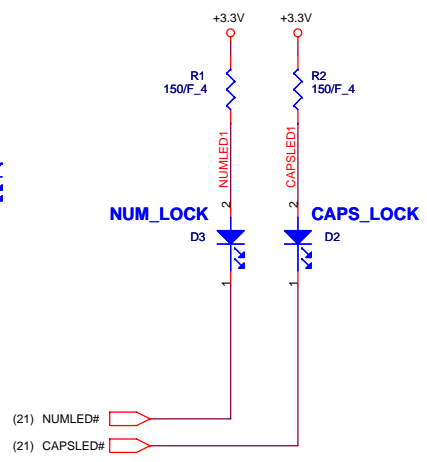

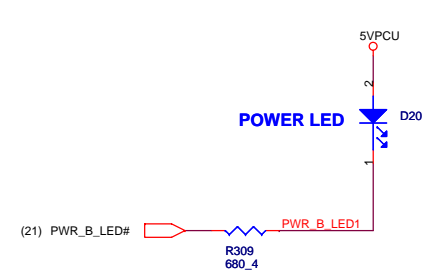

Power Button LED

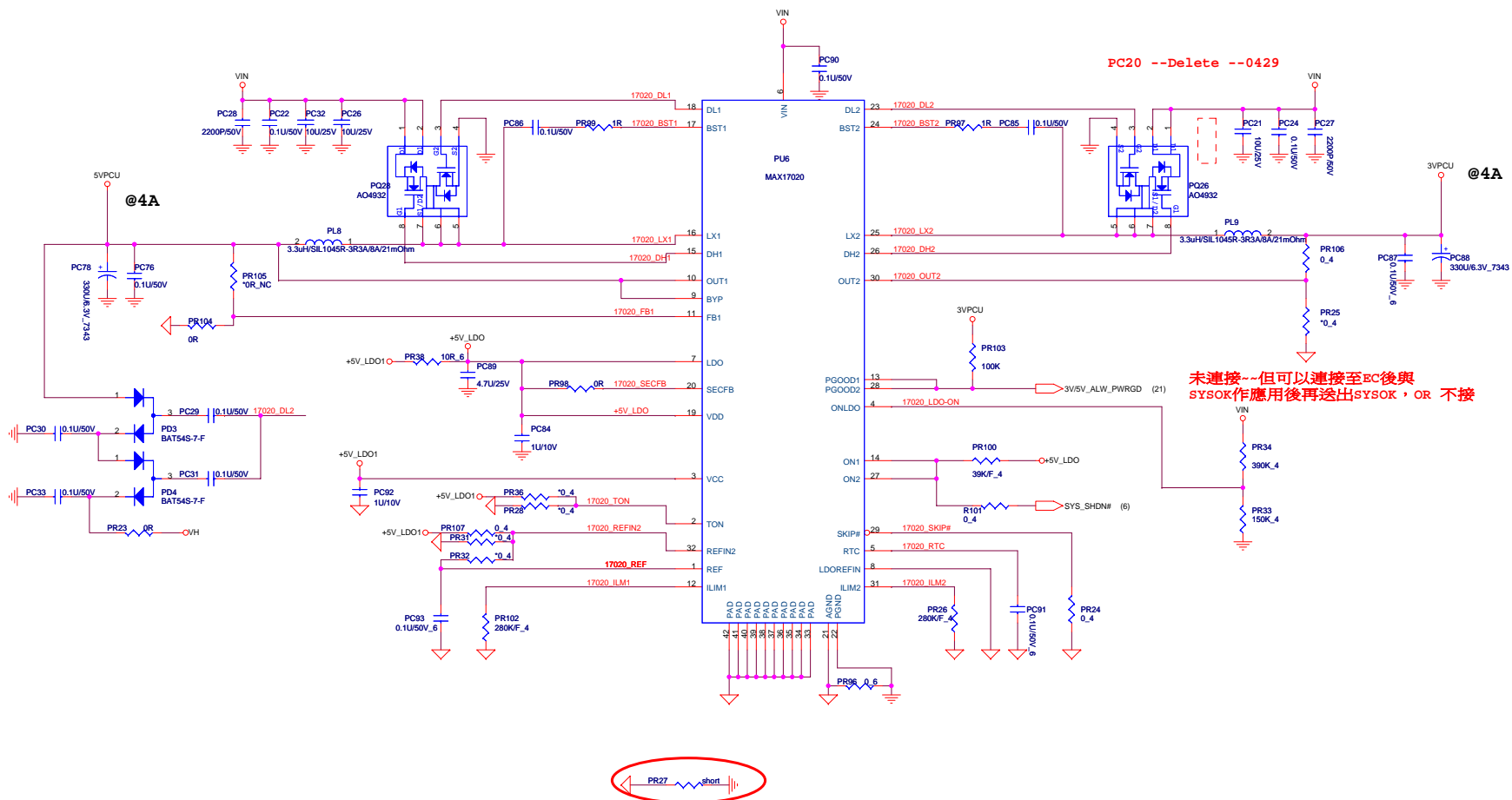

	Q1 & R5	Q16 & R6
SATA	ASM	No-ASM
PATA	No-ASM	ASM

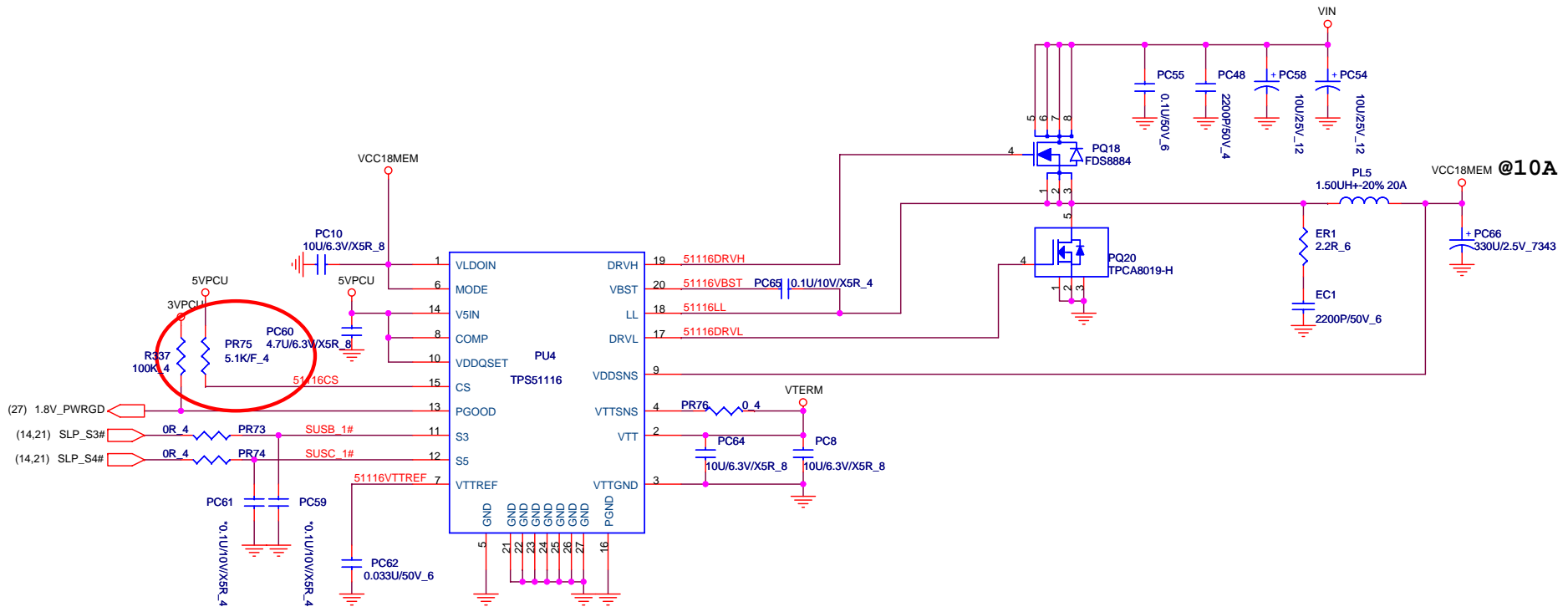



 Quanta Computer Inc. PROJECT : FL1		Rev 1A
Date: Saturday, June 07, 2008		Sheet 30 of 34

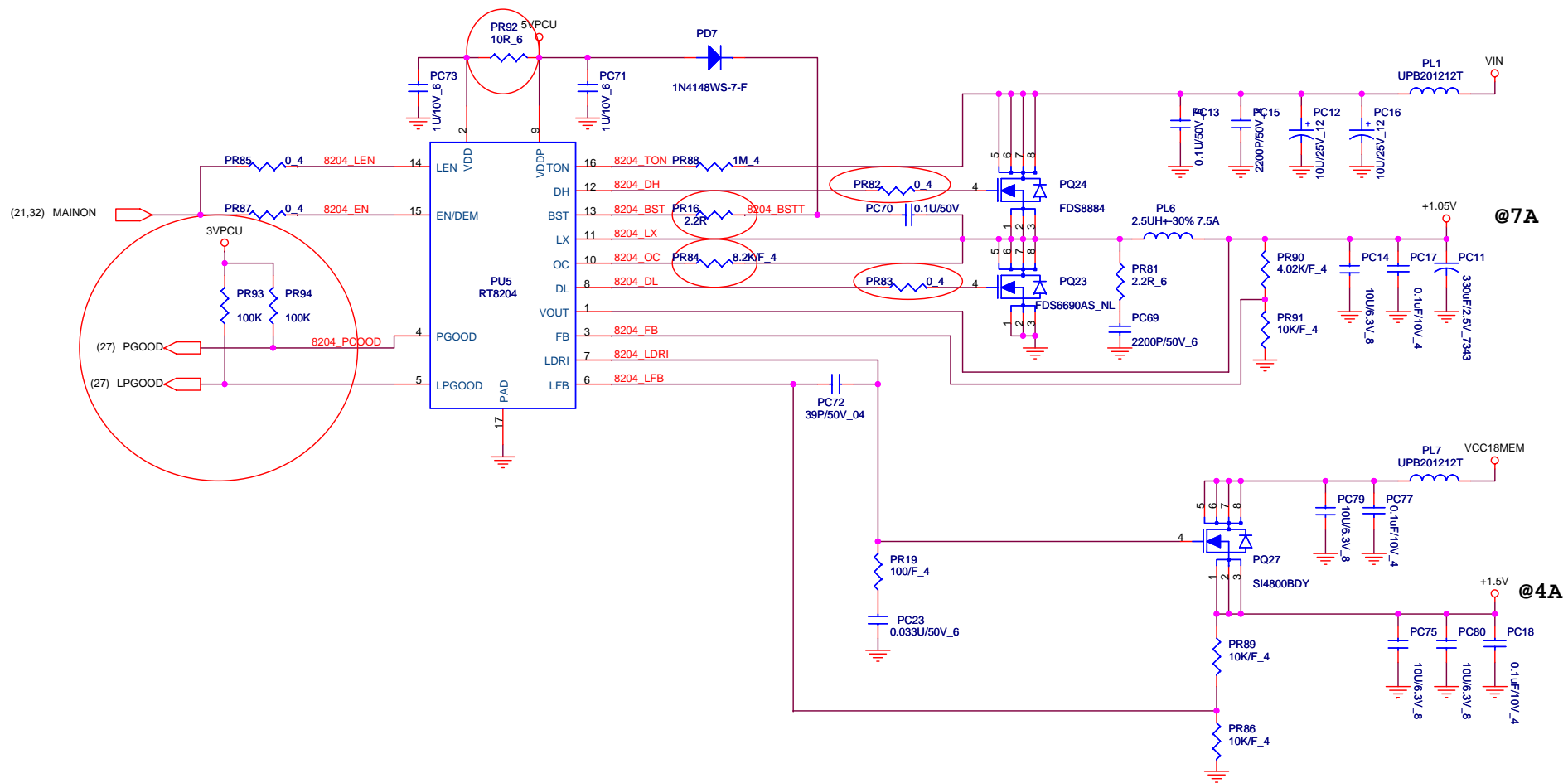

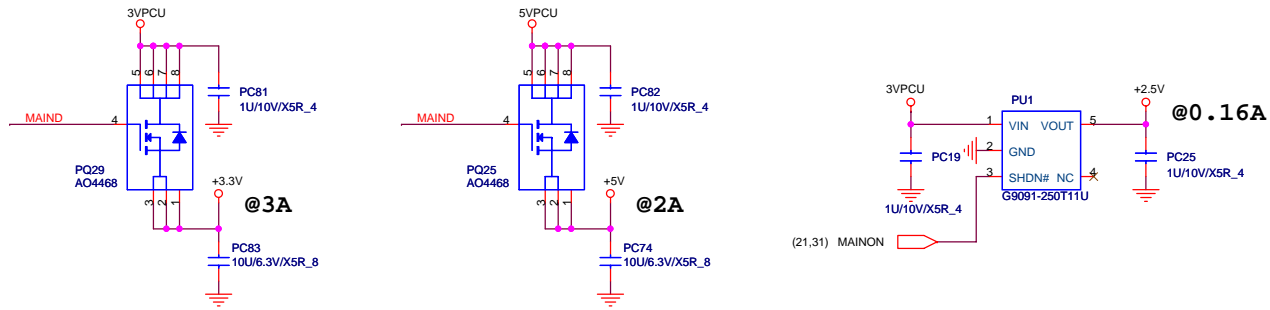

Discharge Circuit Controller by MAINON

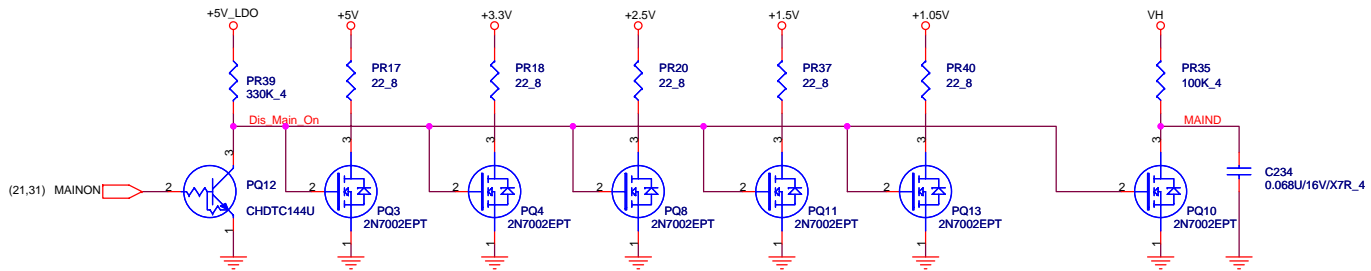

Discharge Circuit Controller by S5_ON

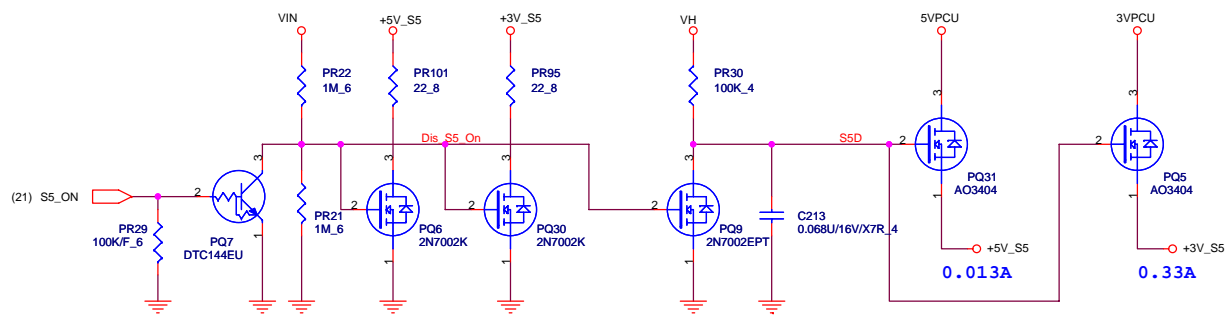

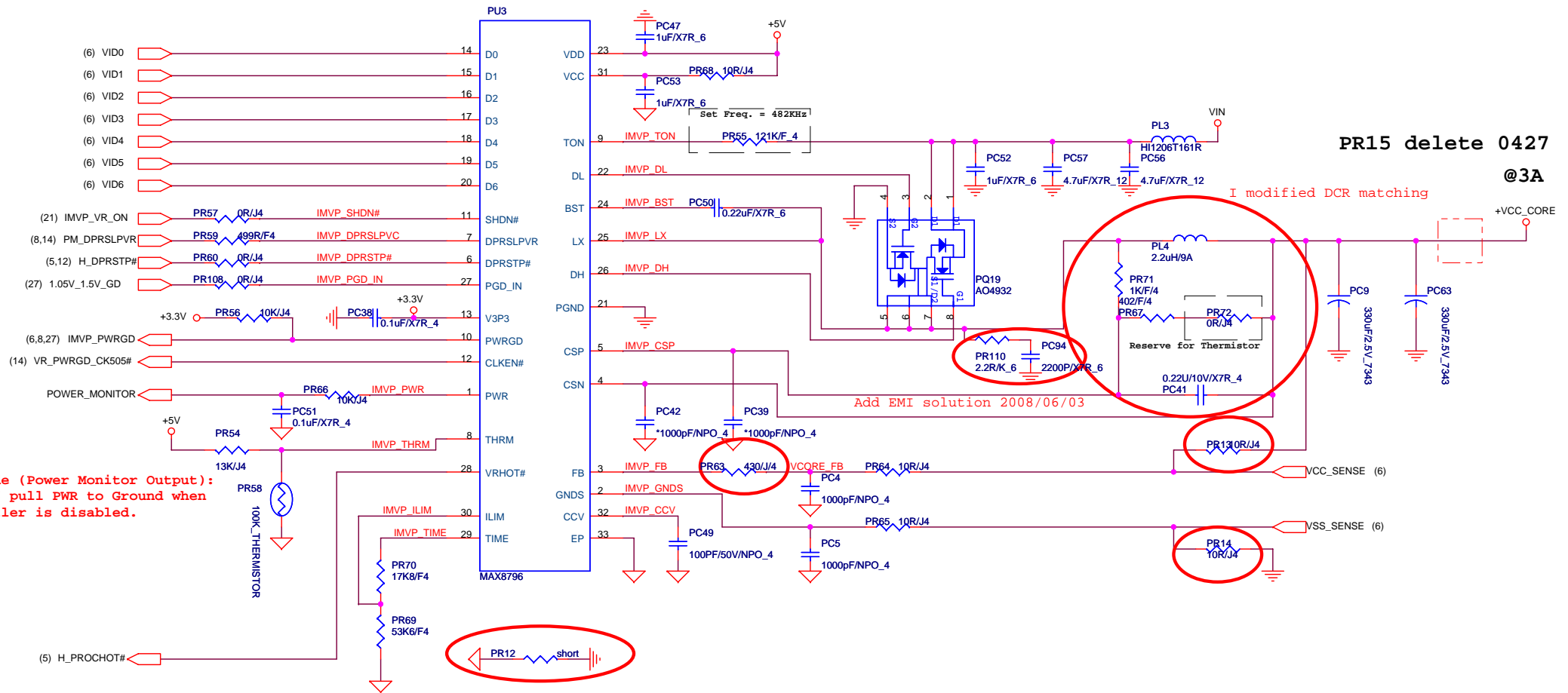

SCREW HOLE

正面沒有接地銅箔,背面有

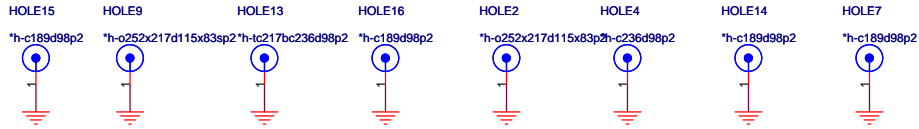

(d: 鑽孔的孔徑)背面有露銅

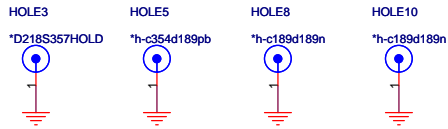

108HOLD



HDD -- HOLD

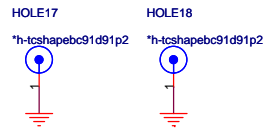

240HOLD

