

R13 INTEL UMA/DISCRETE SYSTEM DIAGRAM

01

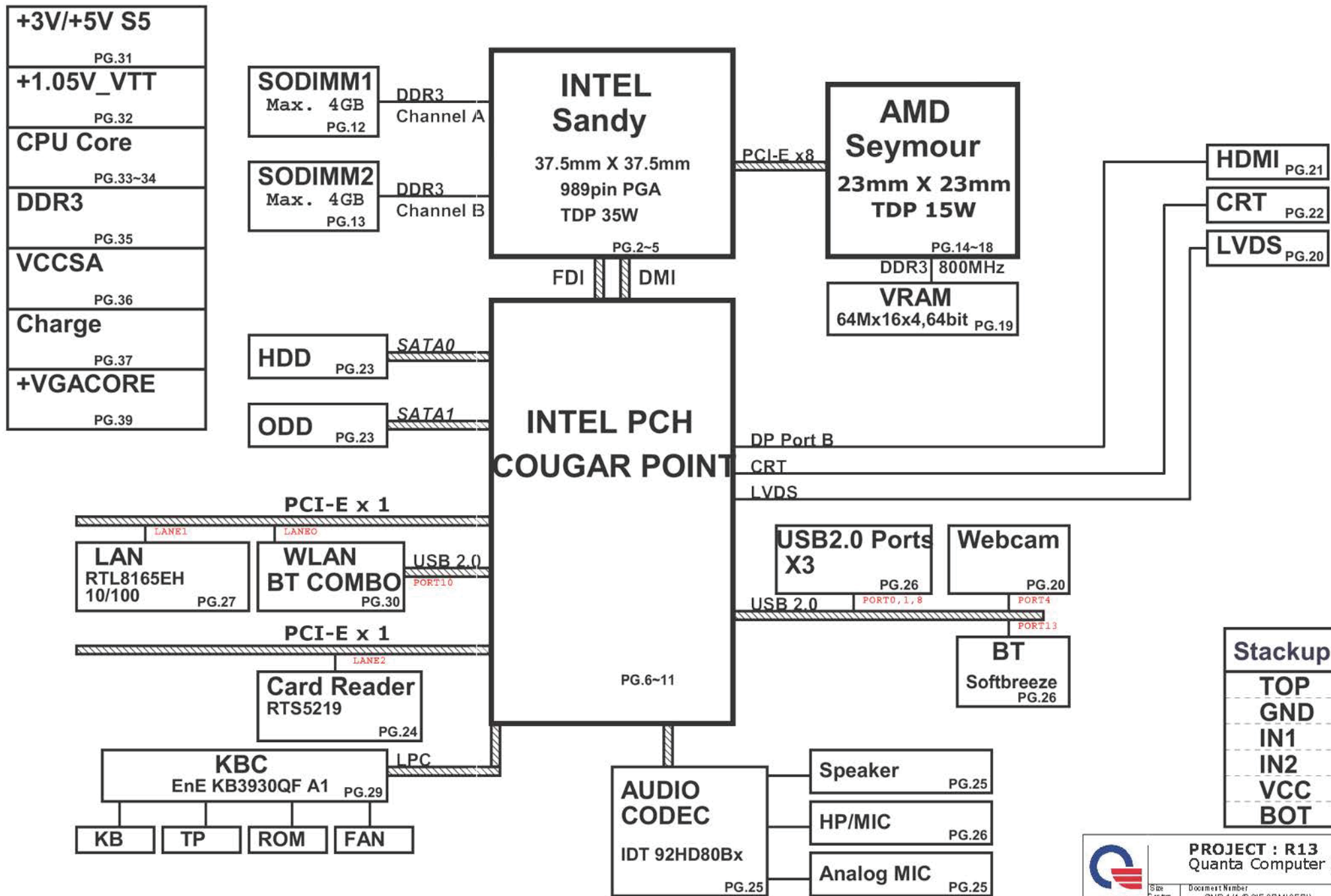

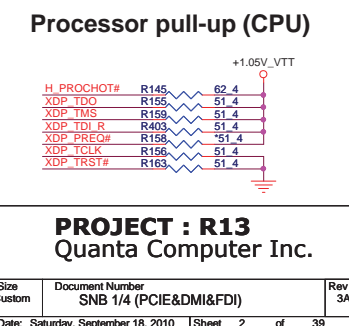
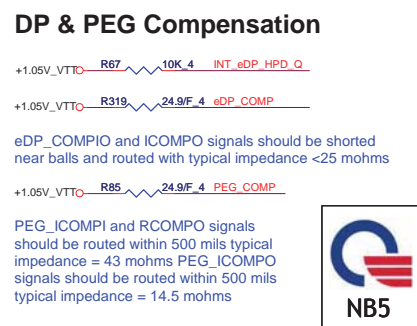
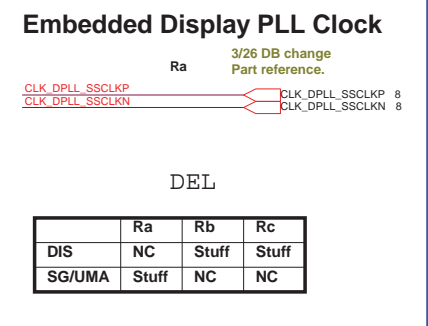
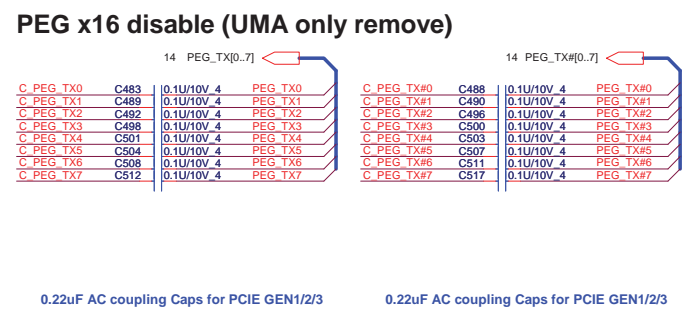
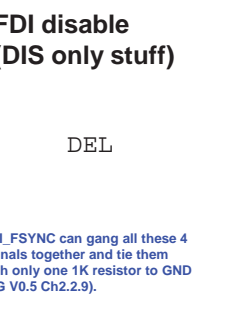
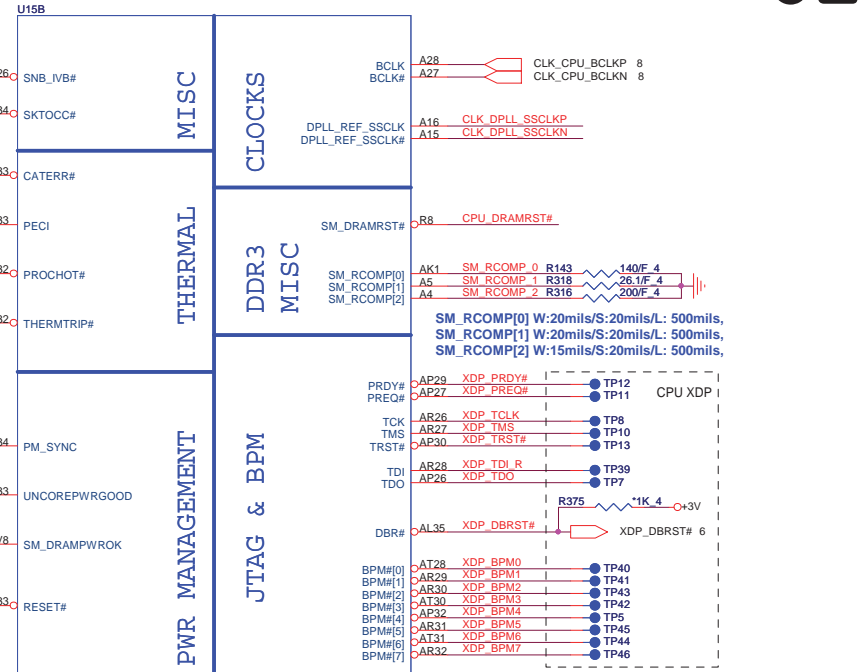
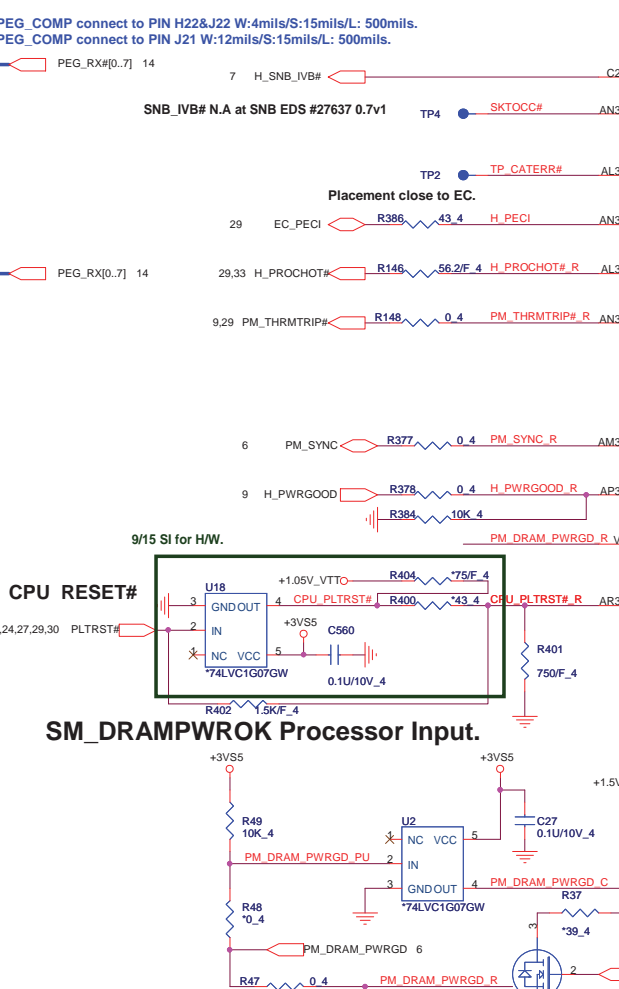
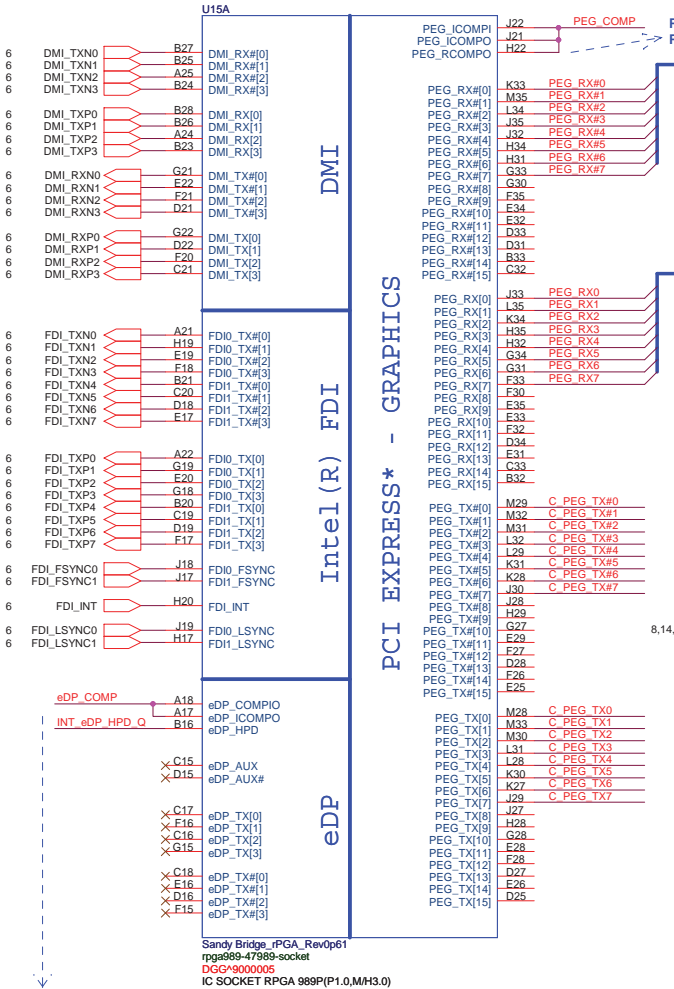

Sandy Bridge Processor (DDR3)

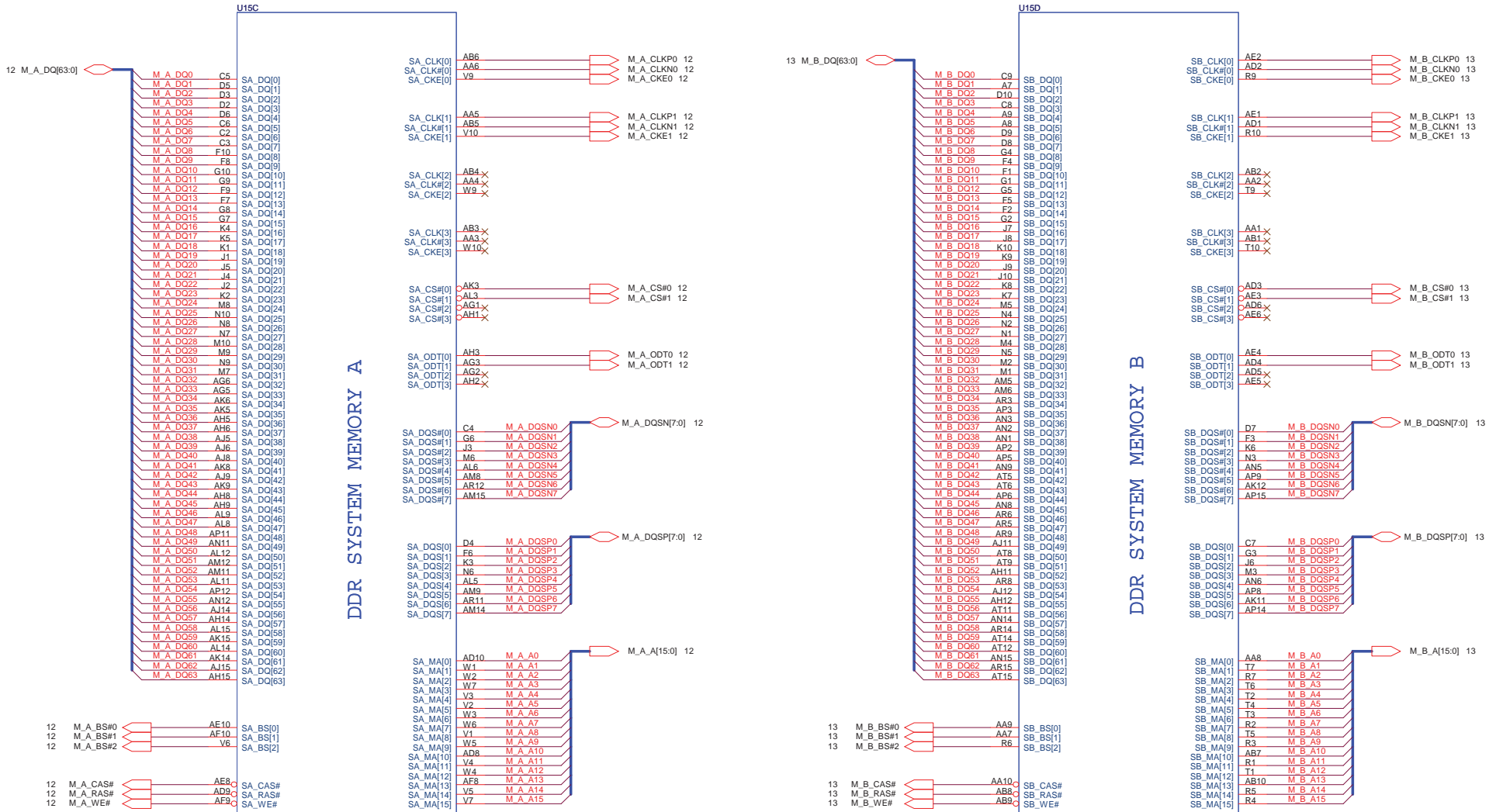

Sandy Bridge_rPGA_Rev0p61
 rpg989-47989-socket
 DGG-9000005
 IC SOCKET RPGA 989P(P1.0,MH3.0)

Sandy Bridge_rPGA_Rev0p61
 rpg989-47989-socket
 DGG-9000005
 IC SOCKET RPGA 989P(P1.0,MH3.0)

	PROJECT : R13		Rev 3A
	Quanta Computer Inc.		
	Size Custom Document Number SNB 2/4 (DDR3 I/F)	Date: Saturday, September 18, 2010	

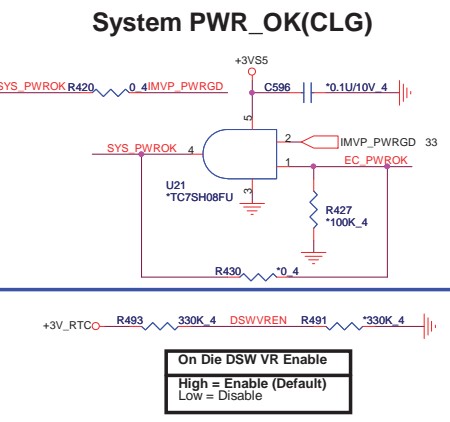
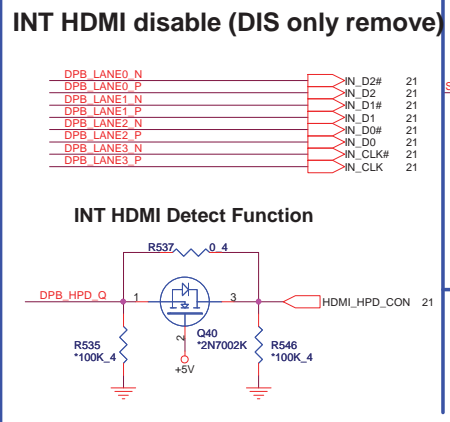
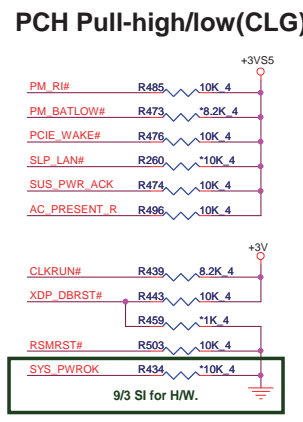
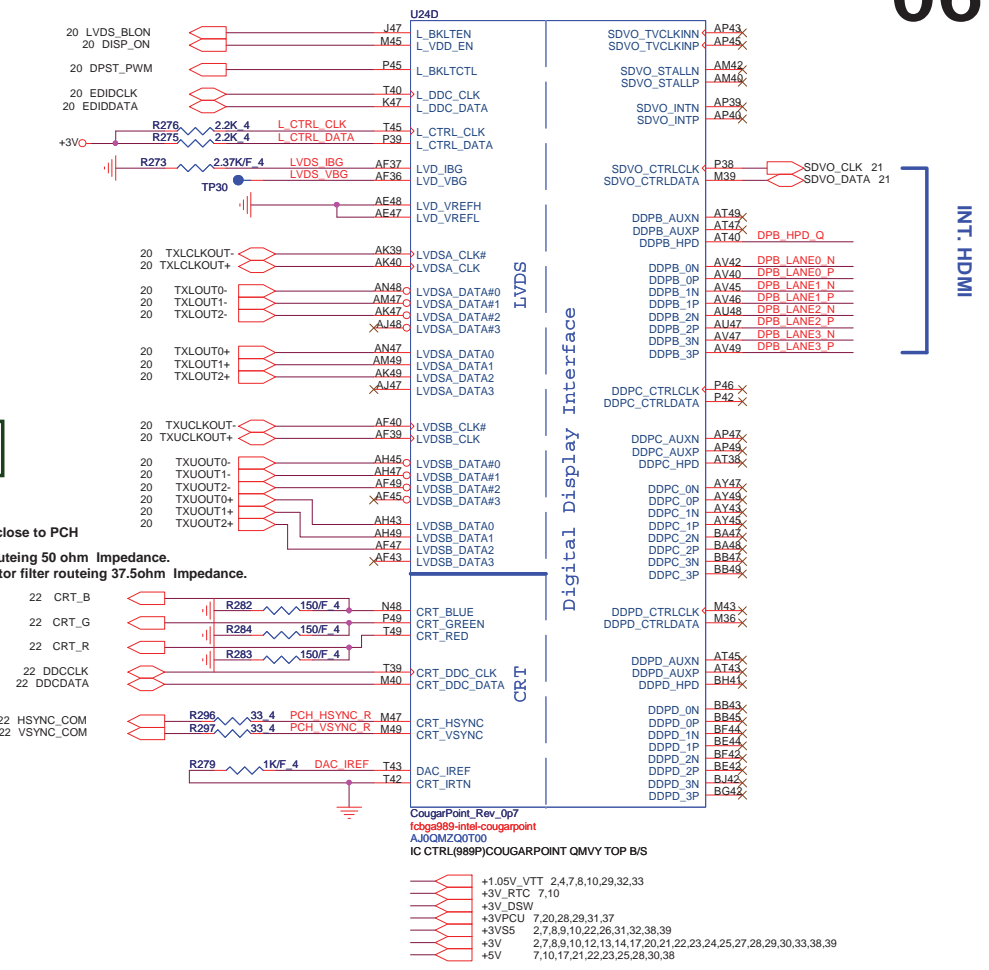
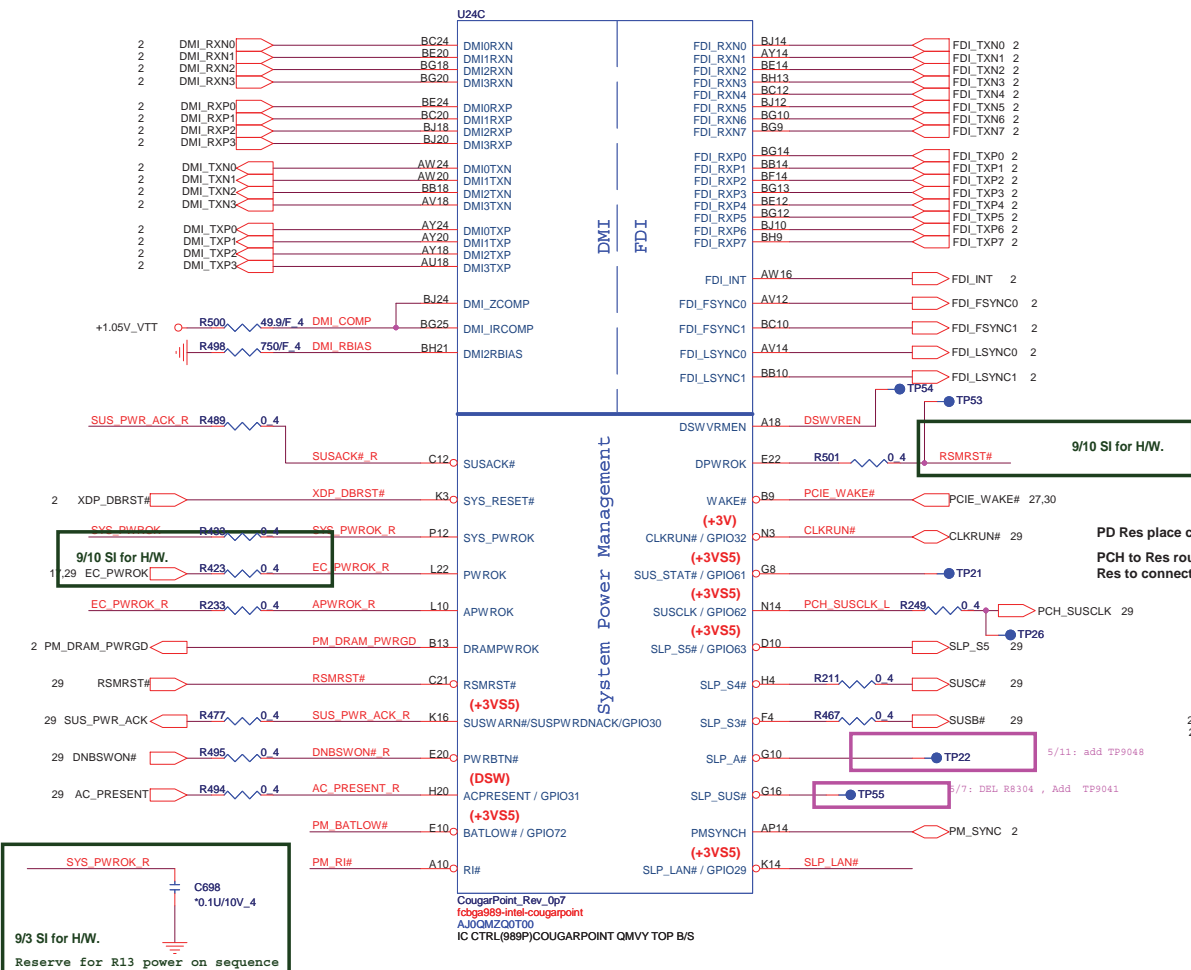

PROJECT : R13
Quanta Computer Inc.

Size Custom Document Number PCH 1/6 (DMI/FDI/VIDEO) Rev 3A

Date: Saturday, September 18, 2010 Sheet 6 of 39

Cougar Point (HDA, JTAG, SATA)

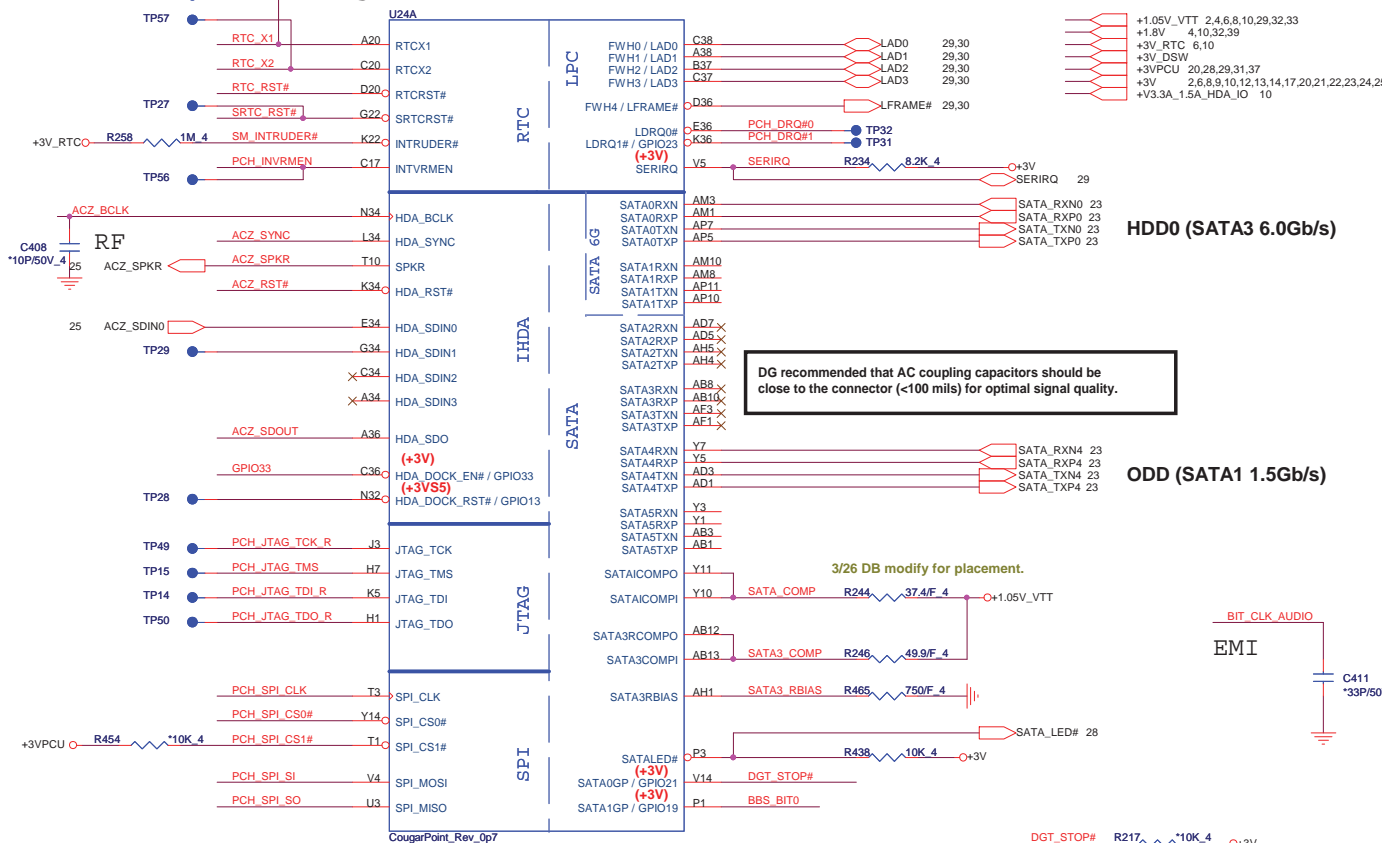

RTC Clock 32.768KHz

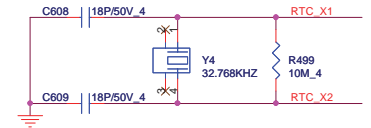

HDD0 (SATA3 6.0Gb/s)



ODD (SATA1 1.5Gb/s)

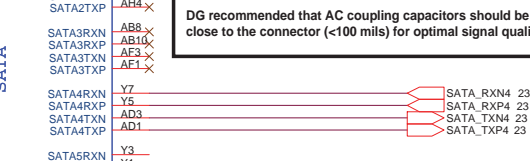

DG recommended that AC coupling capacitors should be close to the connector (<100 mils) for optimal signal quality.

RTC Circuitry(RTC)

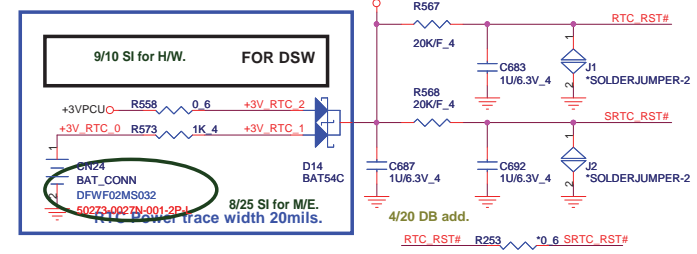

HDA Bus(CLG)

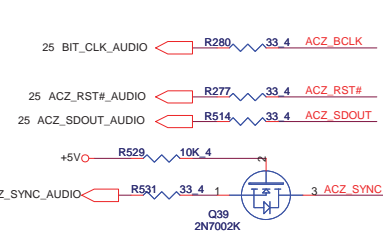

PCH JTAG Debug(CLG)

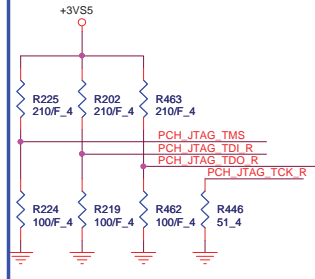

PCH Strap Table

Pin Name	Strap description	Sampled	Configuration	Circuit
SPKR	Different from Calpella No reboot mode setting	PWR0K	0 = Default (weak pull-down 20K) 1 = Setting to No-Reboot mode	ACZ_SPKR R435 *1K 4 +3V
GNT3# / GPIO55	Top-Block Swap Override	PWR0K	0 = "top-block swap" mode 1 = Default (weak pull-up 20K)	R522 *1K 4 R521 10K 4 +3V PCI_GNT3# 8
INTVRMEN	Integrated 1.05V VRM enable	ALWAYS	Should be always pull-up	PCH_INVRMEN R497 330K 4 +3V_RTC
HDA_DOCK_EN#/GPIO33	Flash Descriptor Security Only for Interposer	PWR0K	0 = Override 1 = Default (weak pull-up 20K)	GPIO33 R508 1K 4 GPIO33_E 29
GNT1# / GPIO51	Boot BIOS Selection 1 [bit-1]	PWR0K	[Need external pull-down for LPC BIOS] Default weak pull-up on GNT0/1#	R455 *1K 4 BBS_BIT0
GPIO19	Different from Calpella Boot BIOS Selection 0 [bit-0]	PWR0K		R523 *1K 4 BBS_BIT1 8
GNT2# / GPIO53	ESI strap (Server only)	PWR0K	Should not be pull-down (weak pull-up 20K)	USE GPIO PIN
NV_ALE	Intel Anti-Theft HDD protection Only for Interposer	PWR0K	0 = Disable (Internal pull-down 20kohm)	+1.8V R468 *1K 4 NV_ALE 8
NV_CLE	DMI Termination voltage	PWR0K	weak pull-down 20kohm	+1.8V R470 2.2K 4 R469 4.7K 4 NV_CLE 8 N.A at CPT EDS 0.7 H_SNB_IVB# 2
HDA_SYNC	On-Die PLL VR Voltage Select	RSMRST	0 = Support by 1.8V (weak pull-down) 1 = Support by 1.5V	+3V5 R278 1K 4 ACZ_SYNC
HDA_SDO	Flash Descriptor Security	PWR0K	0 = Override 1 = Default (weak pull-up 20K)	ACZ_SDOUT R510 *1K 4 +V3.3A_1.5A_HDA_IO
GPIO8	Integrated Clock Chip Enable	RSMRST#	Should be pull-down (weak pull-up 20K)	R483 *1K 4 ICC_EN# 9
GPIO28	Different from Calpella On-die PLL Voltage Regulator	RSMRST#	0 = Disable 1 = Enable (Default)	R447 *1K 4 PLL_OVDR_EN 9
SPI_MOSI	iTPM function Disable	APWR0K	0 = Default (weak pull-down 20K) 1 = Enable	PCH_SPI_SI R198 1K 4 +3V

PCH SPI ROM(CLG)

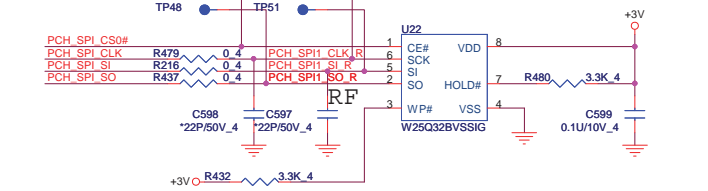

Vender	Size	P/N
EON	4MB	AKE39FN0Q00 (EN25F32-100HIP)
Winbond	4MB	AKE391P0N00 (W25Q32BVSSIG)
Socket		DG008000031

PROJECT : R13

Quanta Computer Inc.

Size	Document Number	Rev
Custom	PCH 2/6 (SATA/HDA/SPI)	3A
Date: Saturday, September 18, 2010 Sheet 7 of 39		

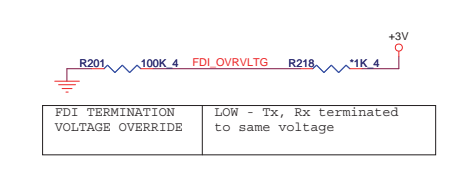
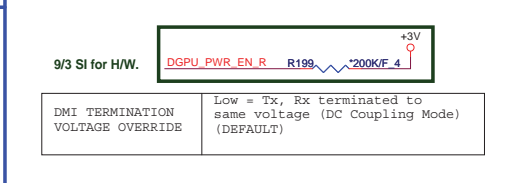
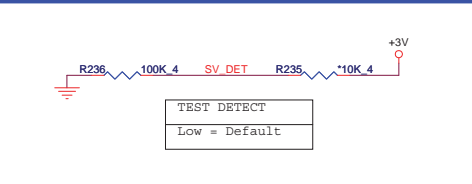
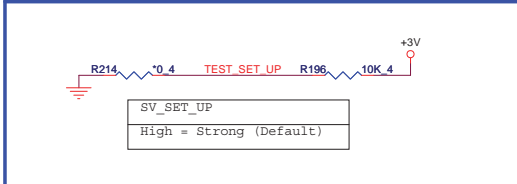
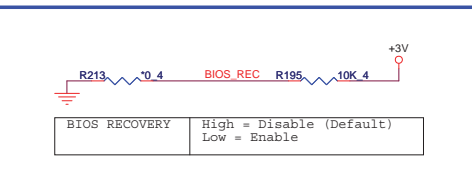
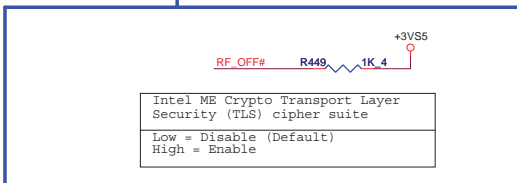
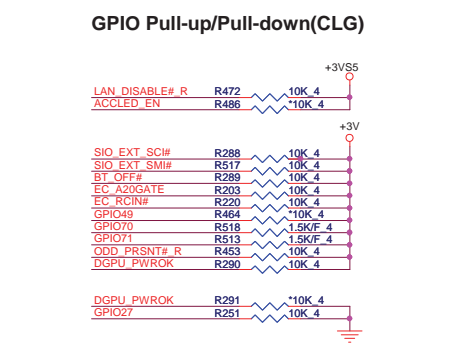
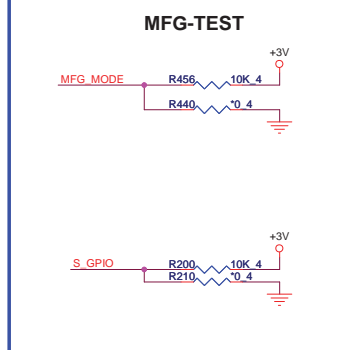
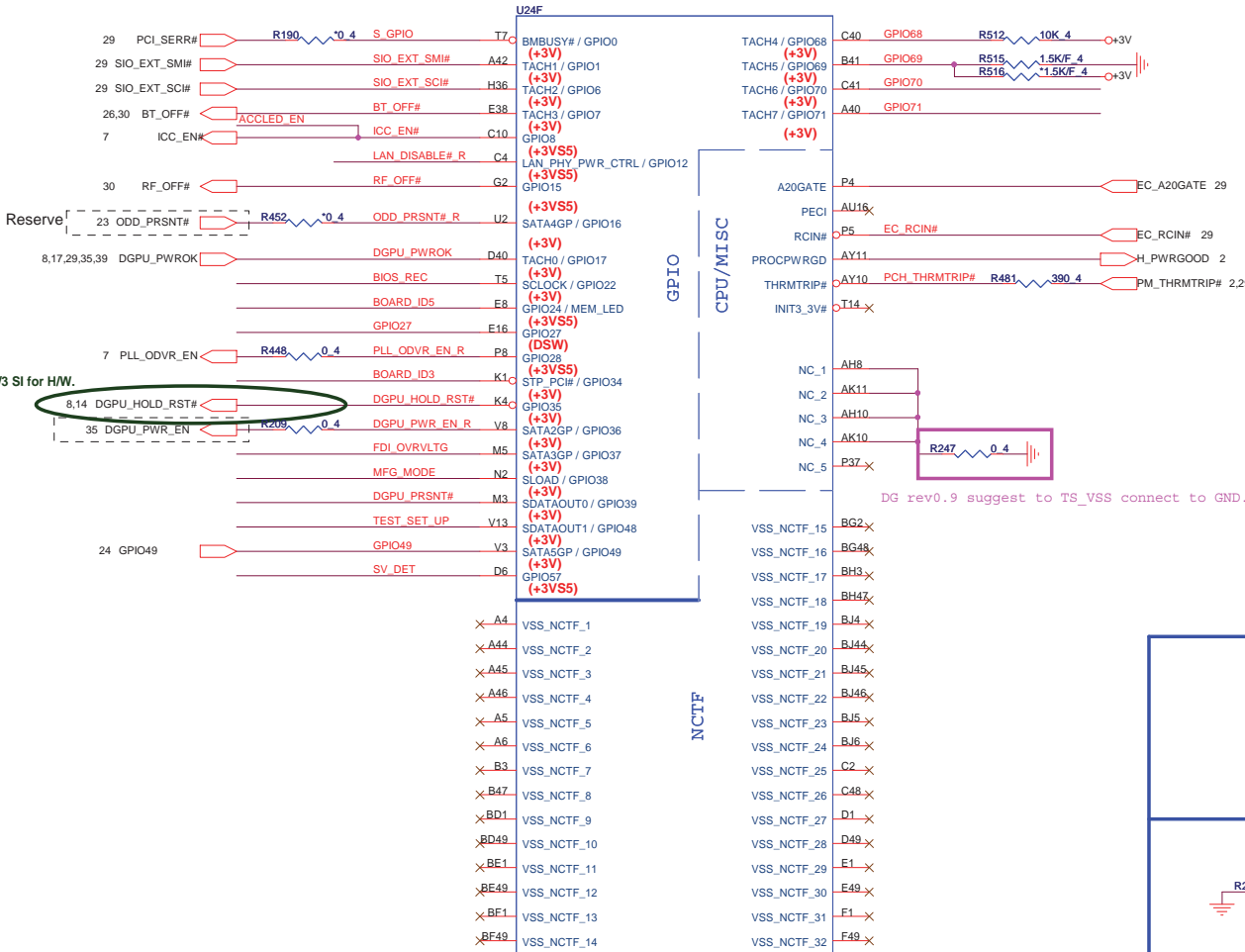

BOARD ID SETTING

Model	BOARD_ID5	BOARD_ID4	BOARD_ID3	BOARD_ID2	BOARD_ID1	BOARD_ID0
R13 UMA	0	0	0	0	0	0
R13 DIS	0	0	0	0	0	1
	0	0	0	0	0	0
	0	0	0	0	0	0
	0	0	0	0	0	0

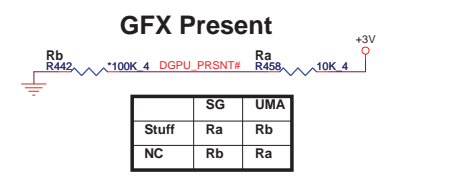
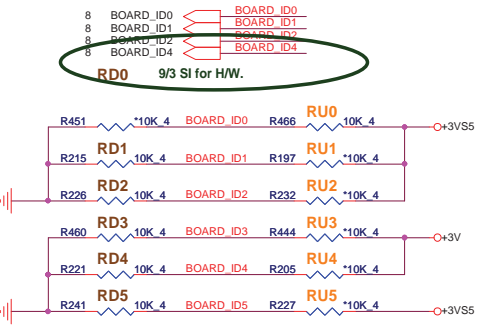

Cougar Point-M (POWER)

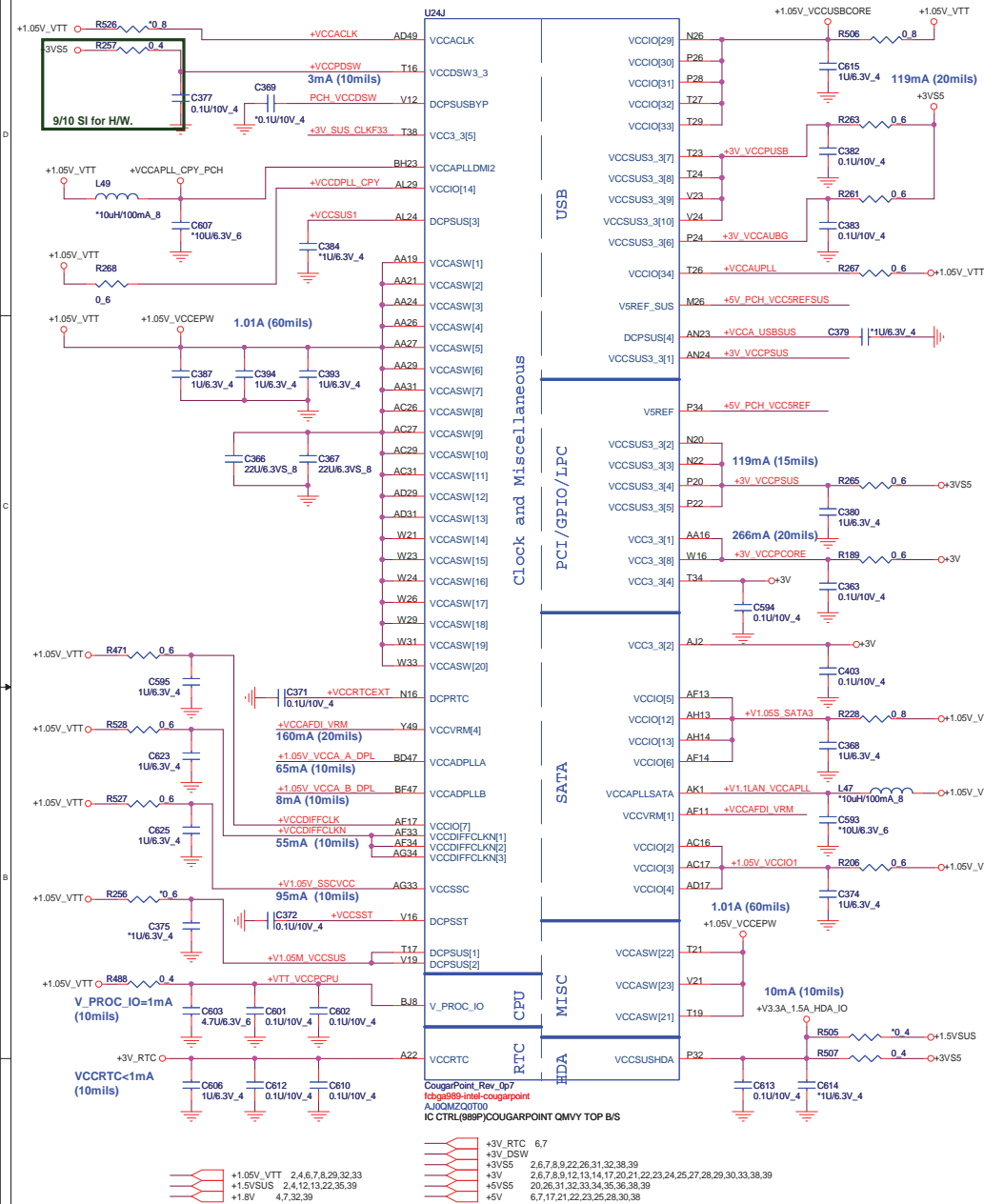

- +3V_RTC 6,7
- +3V_DSWS 2,6,7,8,9,22,26,31,32,38,39
- +3V_S5 2,6,7,8,9,12,13,14,17,20,21,22,23,24,25,27,28,29,30,33,38,39
- +3V 2,6,7,8,9,12,13,14,17,20,21,22,23,24,25,27,28,29,30,33,38,39
- +3V_S5 2,6,7,8,9,12,13,14,17,20,21,22,23,24,25,27,28,29,30,33,38,39
- +5V 6,7,17,21,22,23,25,28,30,38

COUGAR POINT (POWER)

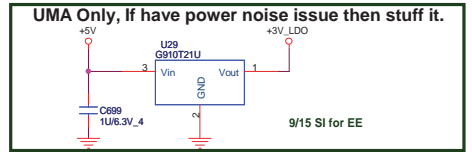
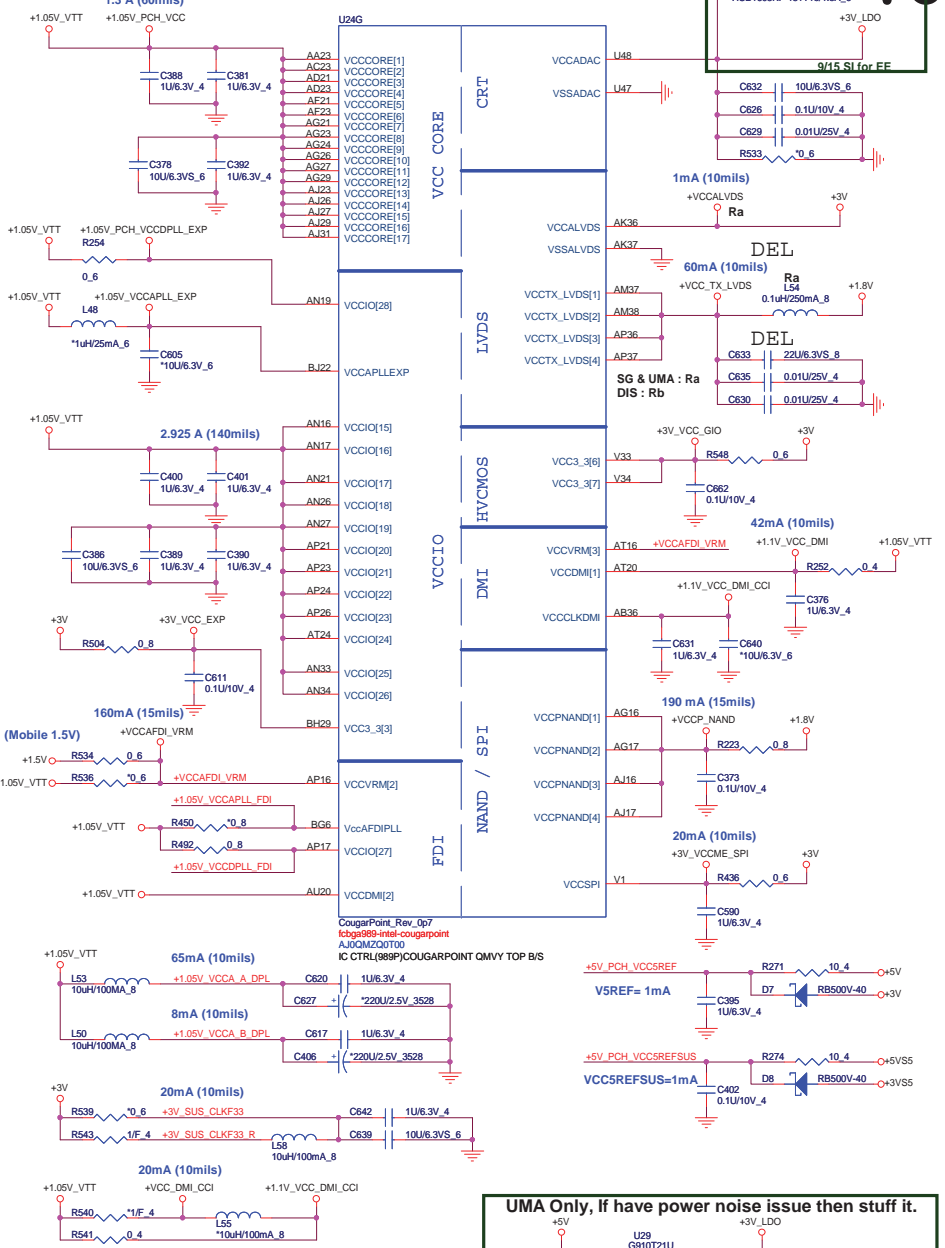

<http://laptop-motherboard-schematic.blogspot.com/>

PROJECT : R13
Quanta Computer Inc.

Size Custom	Document Number PCH 5/6 (POWER)	Rev 3A
Date: Saturday, September 18, 2010 Sheet 10 of 39		

IBEX PEAK-M (GND)

IBEX PEAK-M (GND)

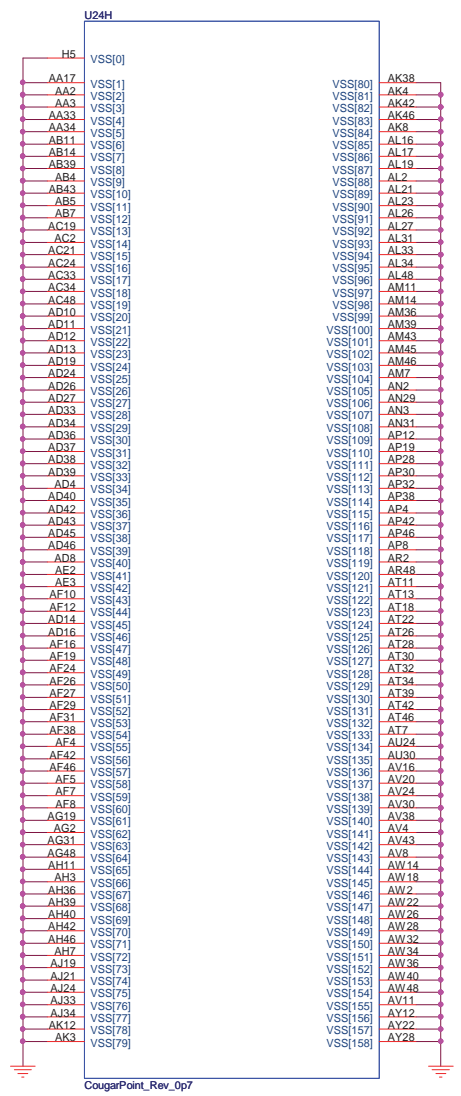
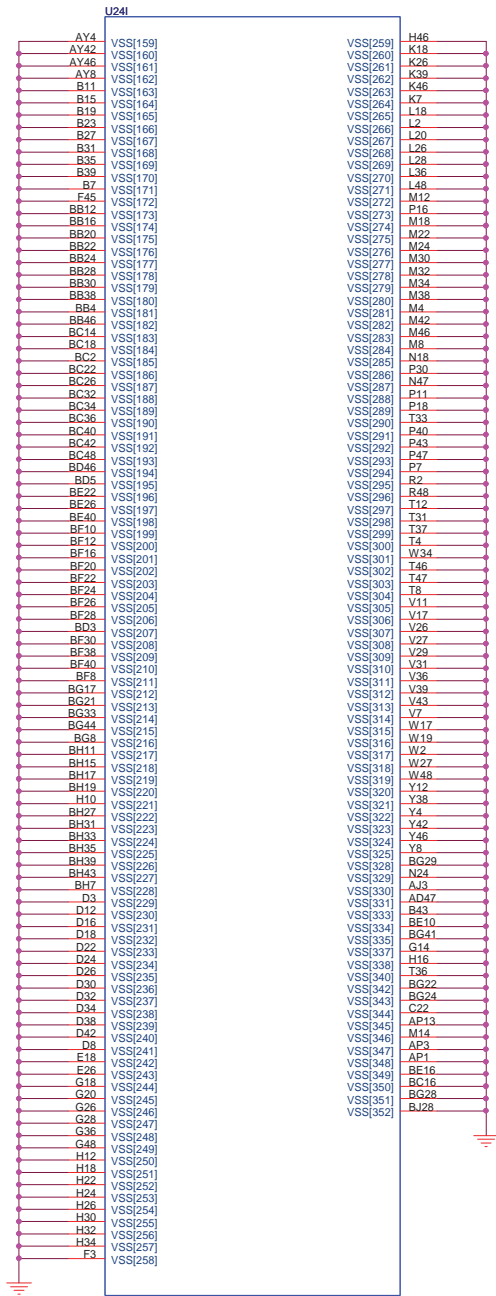

	PROJECT : R13		Rev 3A
	Quanta Computer Inc.		
	Size Custom Document Number PCH 6/6 (GND)	Date: Saturday, September 18, 2010	

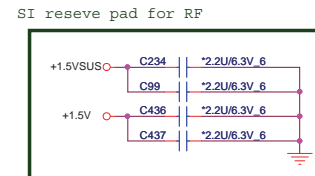
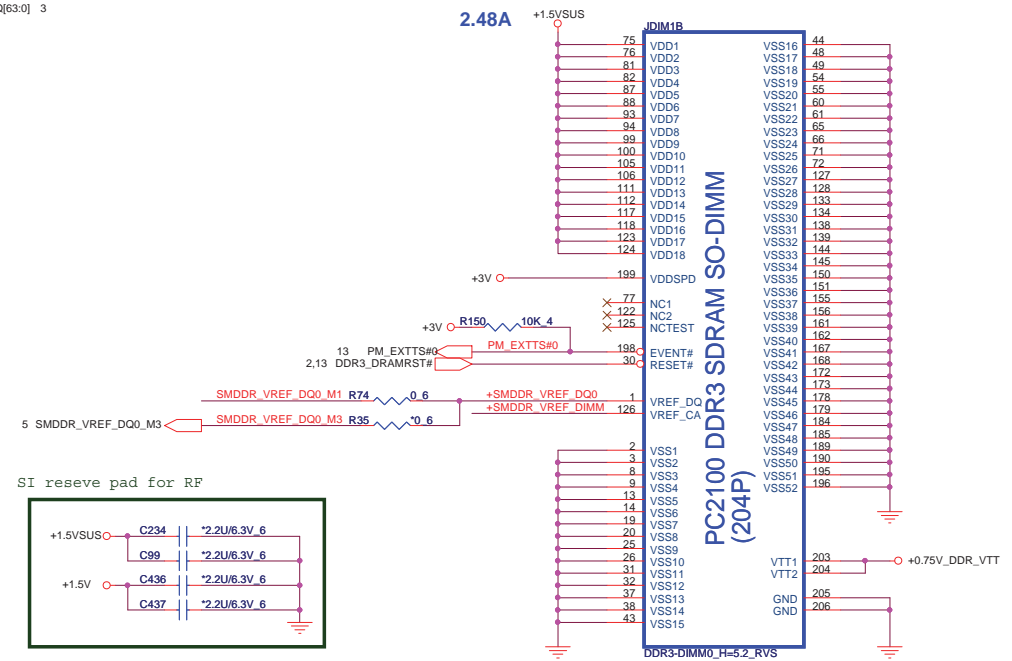
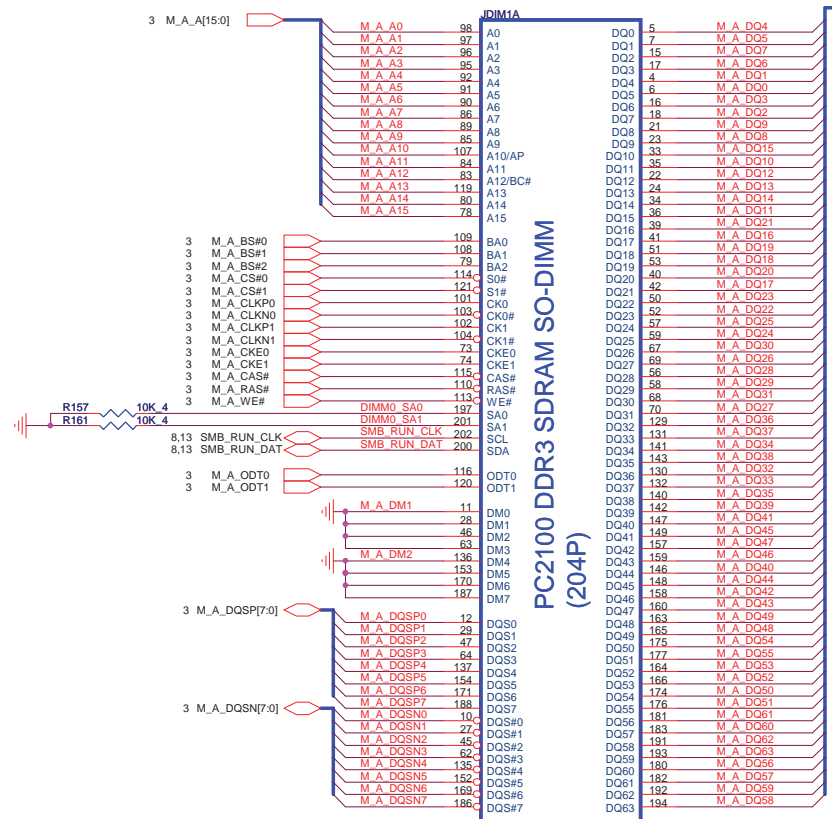

- +0.75V_DDR_VTT 13,35,38
- +1.5VSUS 2,4,10,13,22,35,39
- +3VPCU 7,20,28,29,31,37
- +3V 2,6,7,8,9,10,13,14,17,20,21,22,23,24,25,27,28,29,30,33,38,39
- +5VPCU 29,31,37

VREF DQ0 M2 Solution

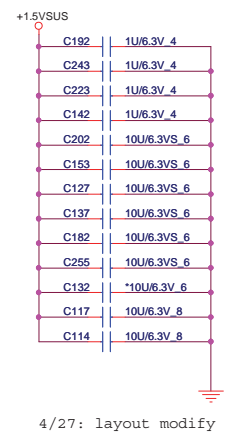

4/27: layout modify

Place these Caps near So-Dimm0.

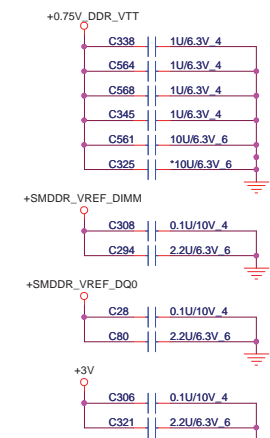

VREF DQ0 M1 Solution

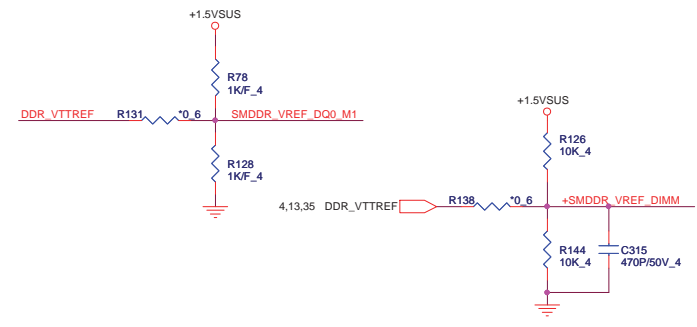

del M2 solution

PROJECT : R13
Quanta Computer Inc.

Size Custom Document Number DDR3 DIMM0-RVS (5.2H) Rev 3A

Date: Saturday, September 18, 2010 Sheet 12 of 39

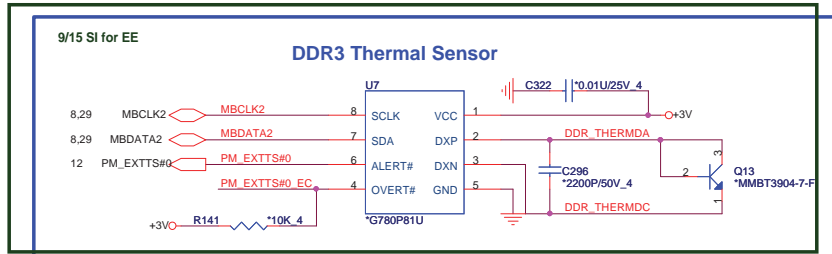
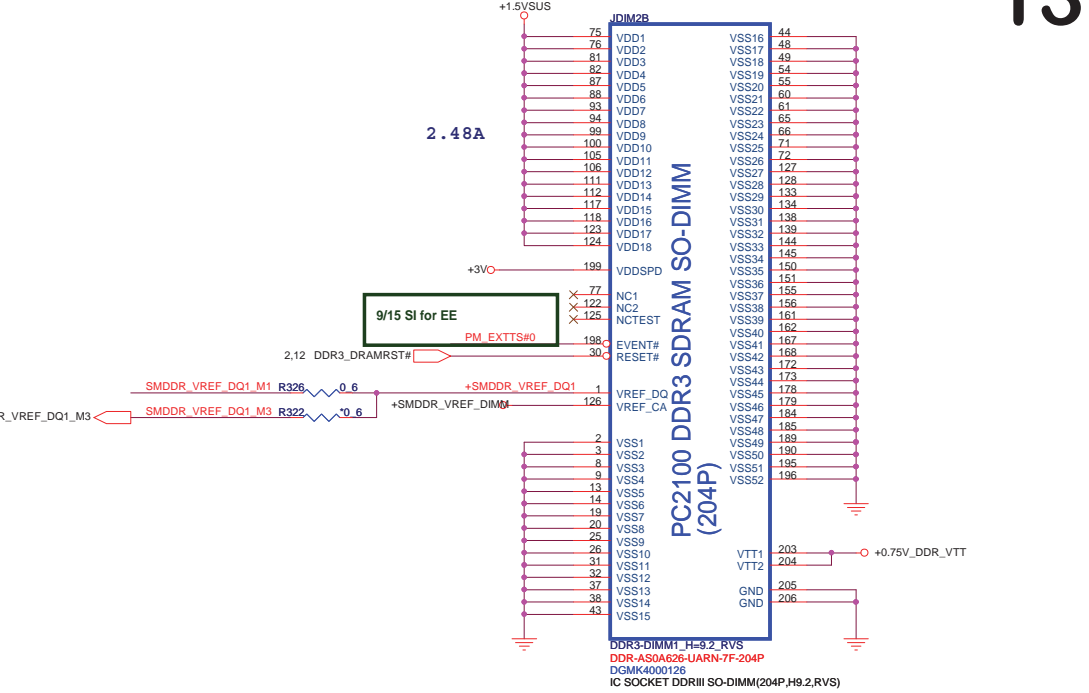
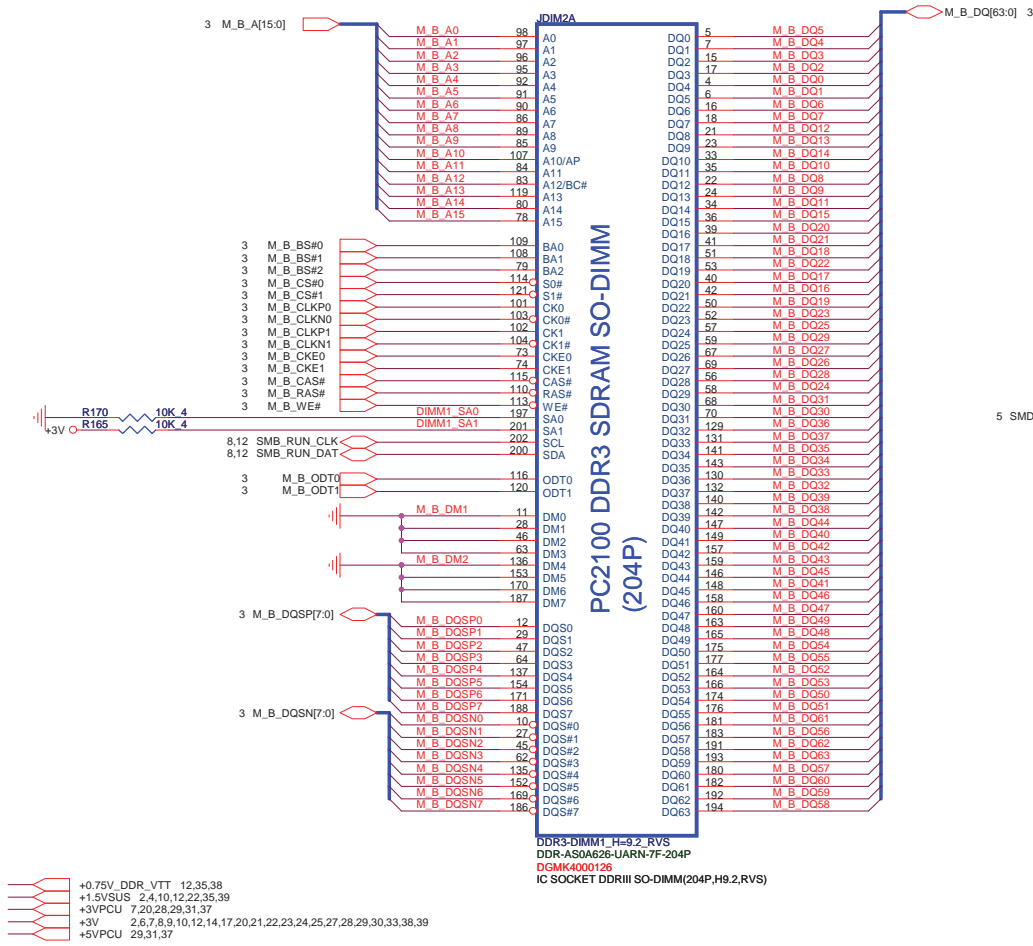

del M2 solution

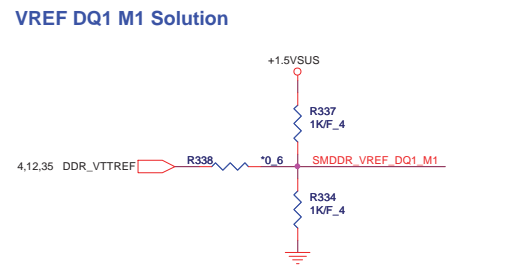
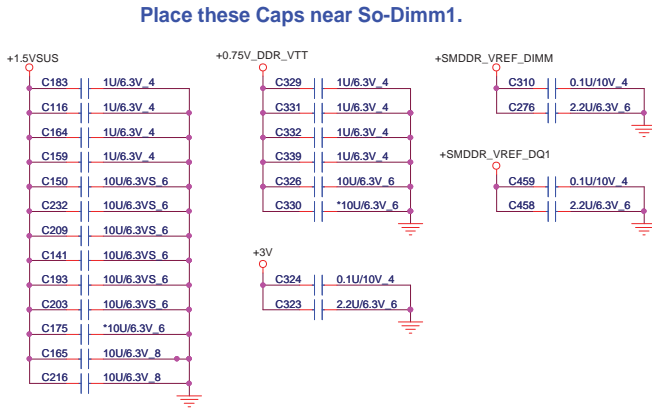

PROJECT : R13
Quanta Computer Inc.

NB5

Size Custom	Document Number DDR3 DIMM1-RVS (9.2H)	Rev 3A
Date: Saturday, September 18, 2010		Sheet 13 of 39

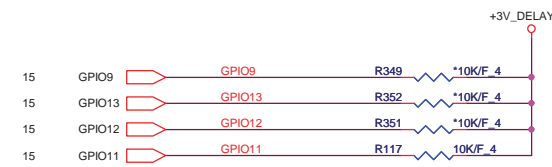
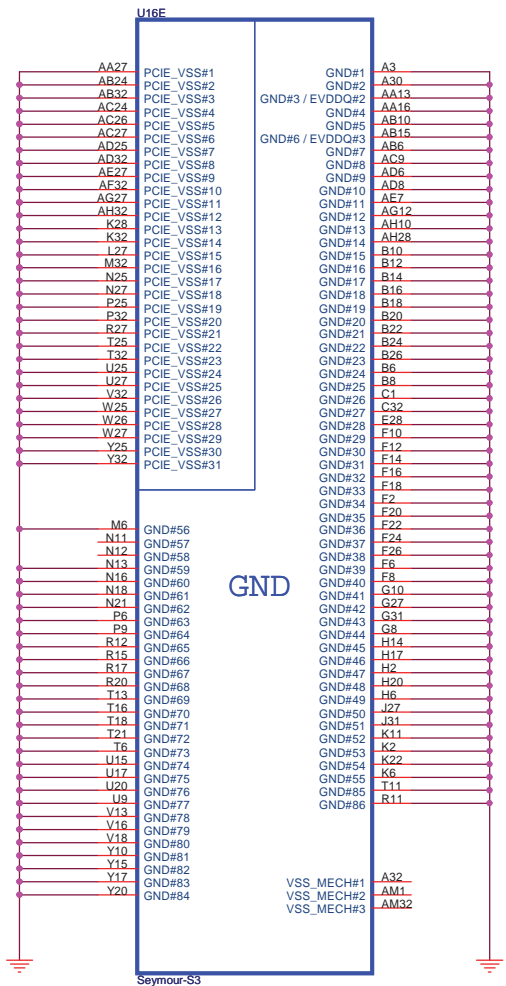

CONFIGURATION STRAPS			RECOMMENDED SETTINGS 0= DO NOT INSTALL RESISTOR 1 = INSTALL 10K RESISTOR X = DESIGN DEPENDANT NA = NOT APPLICABLE
STRAPS	PIN	DESCRIPTION OF DEFAULT SETTINGS	
ALLOW FOR PULLUP PADS FOR THESE STRAPS AND IF THESE GPIOs ARE USED, THEY MUST NOT CONFLICT DURING RESET			
TX_PWRS_ENB	GPIO0	Transmitter Power Savings Enable 0: 50% Tx output swing for mobile mode 1: full Tx output swing (Default setting for Desktop)	1
TX_DEEMPH_EN	GPIO1	PCI Express Transmitter De-emphasis Enable 0: Tx de-emphasis disabled for mobile mode 1: Tx de-emphasis enabled (Default setting for Desktop)	1
BIF_GEN2_EN_A	GPIO2	Enable CLKREQ# Power Management 0 - CLKREQ# power management capability is disabled 1 - CLKREQ# power management capability is enabled	0
RSVD BIF_VGA_DIS RSVD	GPIO8 GPIO9 GPIO21	VGA ENABLED	0 0 0
BIOS_ROM_EN	GPIO_22_ROMCSB	ENABLE EXTERNAL BIOS ROM	0
ROMIDCFG(2:0)	GPIO[13:11]	SERIAL ROM TYPE OR MEMORY APERTURE SIZE SELECT	0 0 1
VIP_DEVICE_STRAP_ENA	V2SYNC	IGNORE VIP DEVICE STRAPS	0
RSVD AUD[1] AUD[0]	GENERICC HSYNC VSYNC	AUD[1] AUD[0] 0 0 No audio function 0 1 Audio for DisplayPort and HDMI if dongle is detected 1 0 Audio for DisplayPort only 1 1 Audio for both DisplayPort and HDMI	0 0 11

AMD RESERVED CONFIGURATION STRAPS		
ALLOW FOR PULLUP PADS FOR THESE STRAPS AND IF THESE GPIOs ARE USED, THEY MUST NOT CONFLICT DURING RESET		
H2SYNC	GENERICC	
PULLUP PADS ARE NOT REQUIRED FOR THESE STRAPS BUT IF THESE GPIOs ARE USED, THEY MUST NOT CONFLICT DURING RESET		
GPIO21_BB_EN		

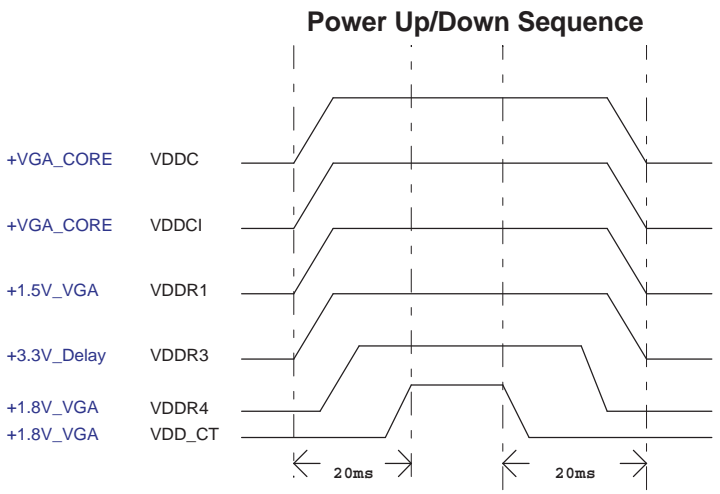

Memory Aperture size					
GPIO9	GPIO13	GPIO12	GPIO11		
BIOSROM	ROMIDCFG2	ROMIDCFG1	ROMIDCFG0		
0	128M	0	0	0	
0	256M	0	0	1	
0	64M	0	1	0	
0	32M	0	1	1	
0	512M	1	0	0	
0	1G	1	0	1	
0	2G	1	1	0	
0	4G	1	1	1	

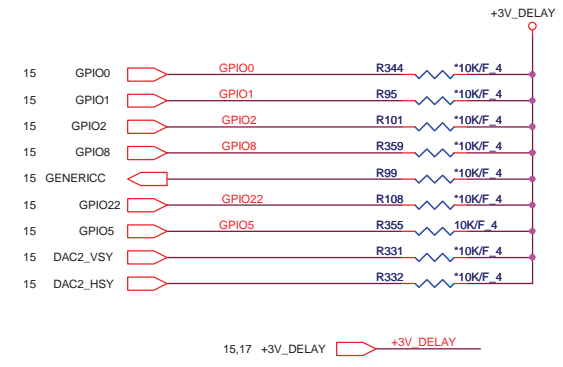

It is a shared pin strap with CONFIG[2:0] if BIOS_ROM_EN is set to 0.

<http://laptop-motherboard-schematic.blogspot.com/>

PROJECT : R13
Quanta Computer Inc.

Size Custom	Document Number	Rev 3A
Seymour GND / LVDS/ Straps		
Date: Saturday, September 18, 2010	Sheet 16	of 39

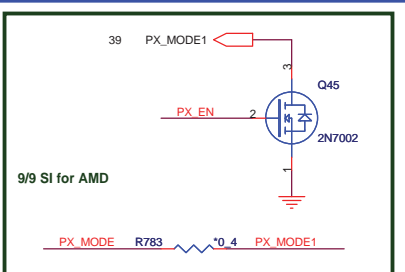
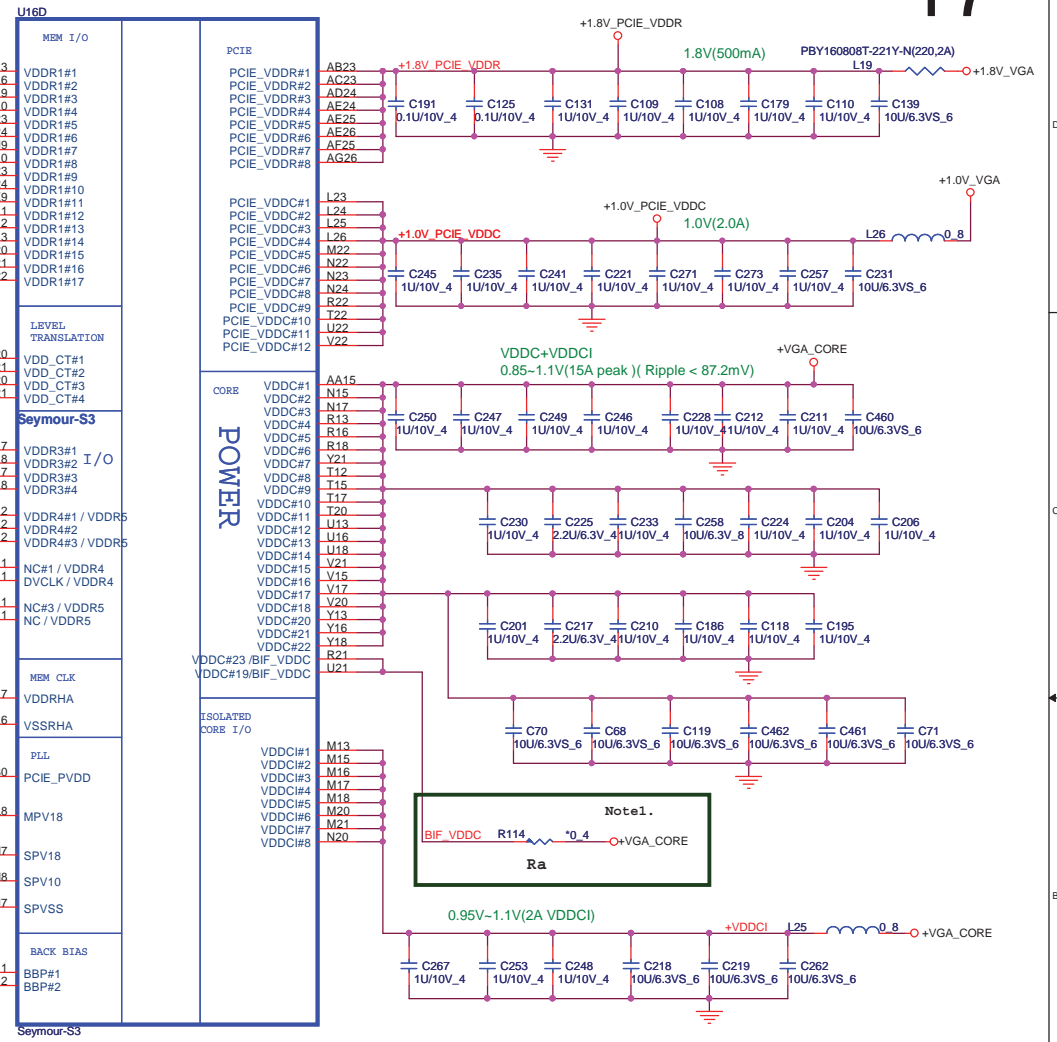
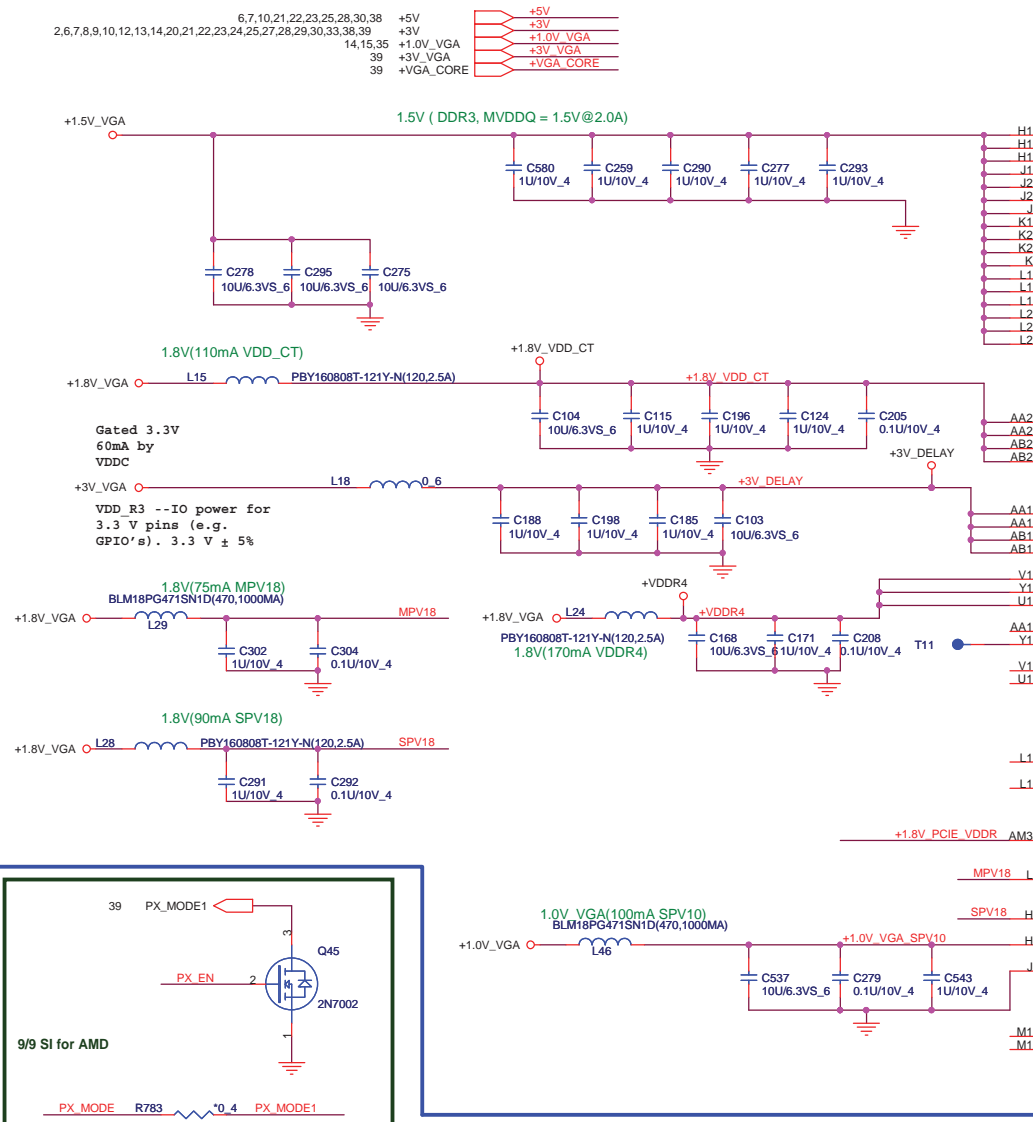

Support BACO Mode

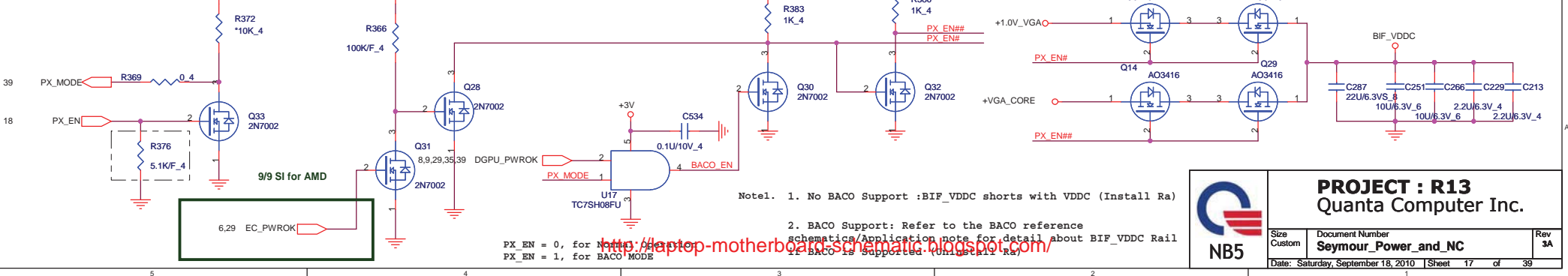

Note1. 1. No BACO Support :BIF_VDDC shorts with VDDC (Install Ra)
 2. BACO Support: Refer to the BACO reference schematics/Application note for detail about BIF_VDDC rail. BACO is supported only on Ra.

PROJECT : R13
Quanta Computer Inc.

NB5

Size Custom	Document Number Seymour_Power_and_NC	Rev 3A
Date: Saturday, September 18, 2010		Sheet 17 of 39

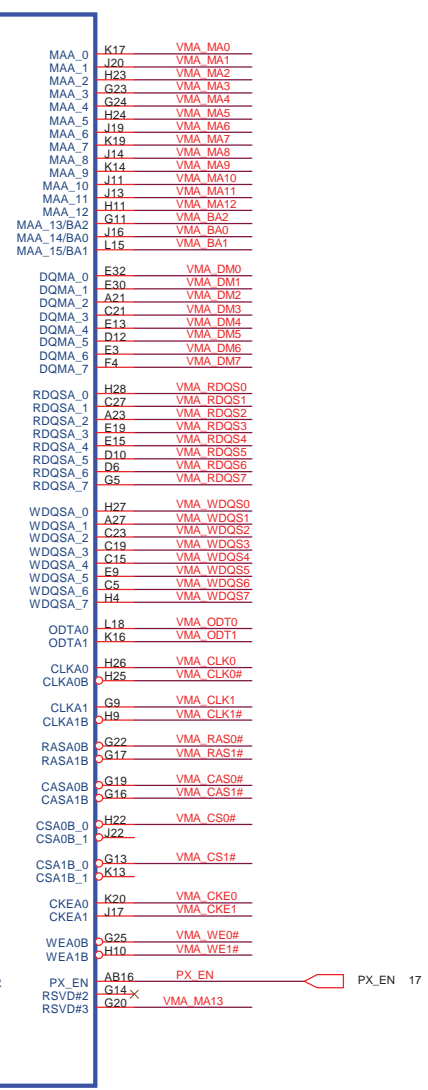
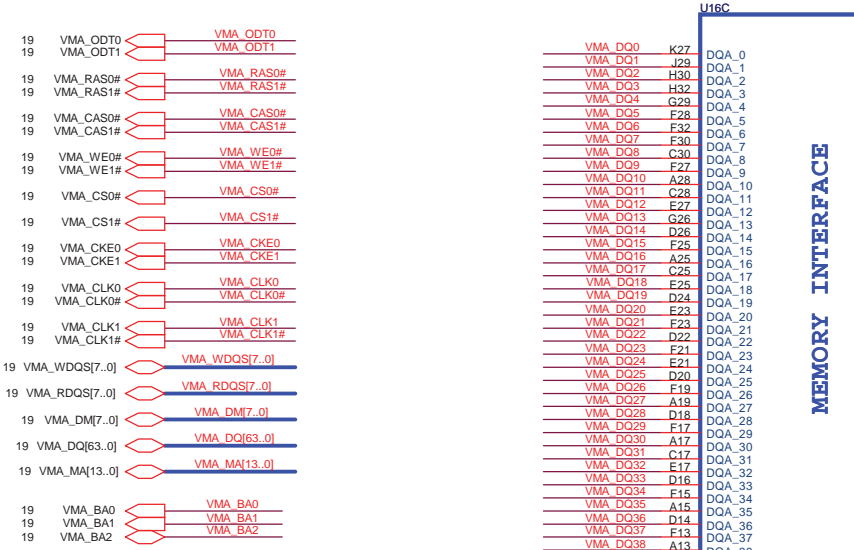

MEMORY INTERFACE

support 1Gbit
VRAM (64M X 16)

DIVIDER RESISTORS	GDDR5	DDR3
MVREF TO 1.8V (Ra)	40.2R	40.2R
MVREF TO GND (Rb)	100R	100R

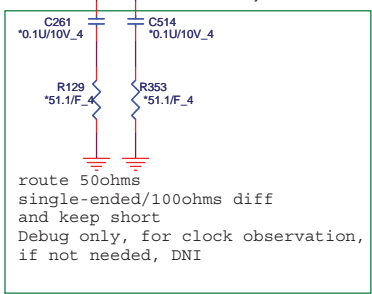
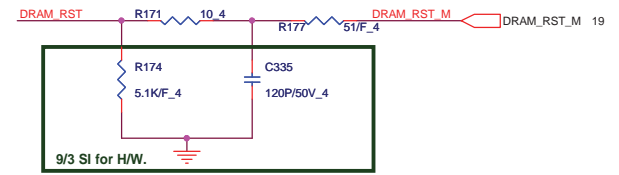
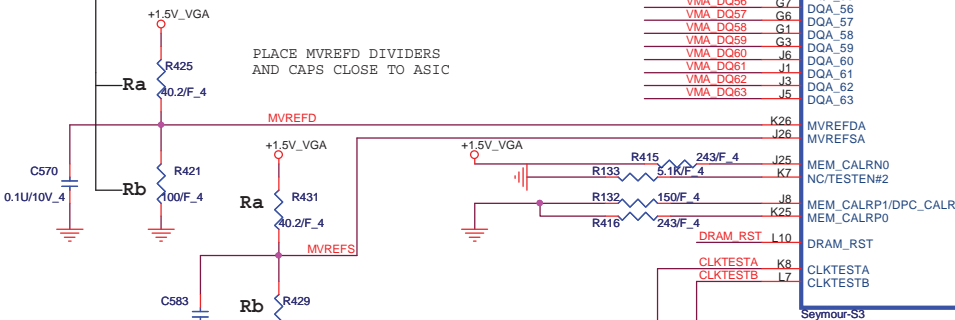

route 50ohms
single-ended/100ohms diff
and keep short
Debug only, for clock observation,
if not needed, DNI

PROJECT : R13
Quanta Computer Inc.

Size Custom	Document Number Seymour/MEM_Interface	Rev 3A
Date: Saturday, September 18, 2010 Sheet 18 of 39		

512MB DDR3

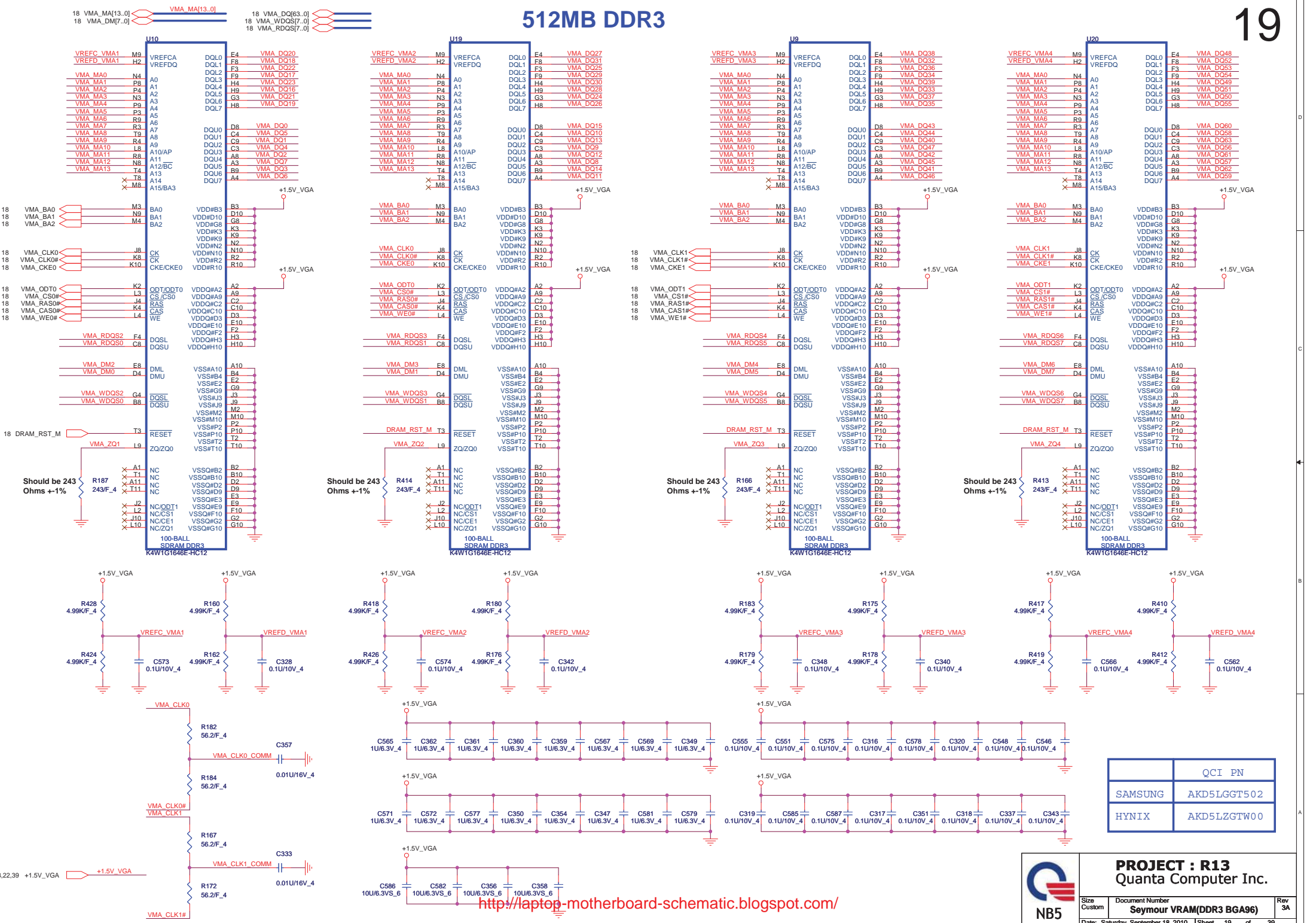

	QCI PN
SAMSUNG	AKD5LGGT502
HYNIX	AKD5LZGTW00

PROJECT : R13
Quanta Computer Inc.

Size Custom Document Number **Seymour VRAM(DDR3 BGA96)** Rev 3A
 Date: Saturday, September 18, 2010 | Sheet 19 of 39

<http://laptop-motherboard-schematic.blogspot.com/>

LID Switch

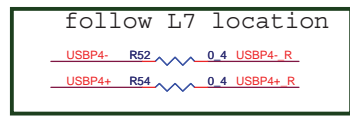
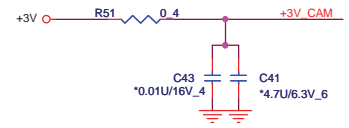
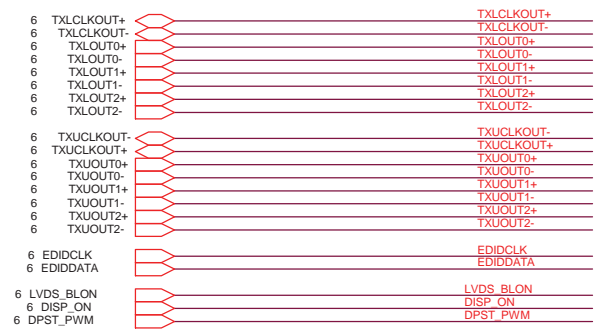
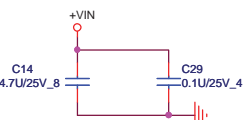
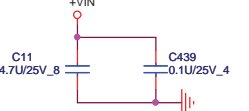
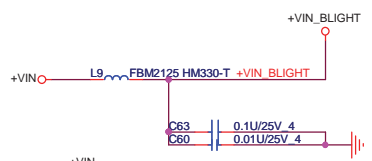
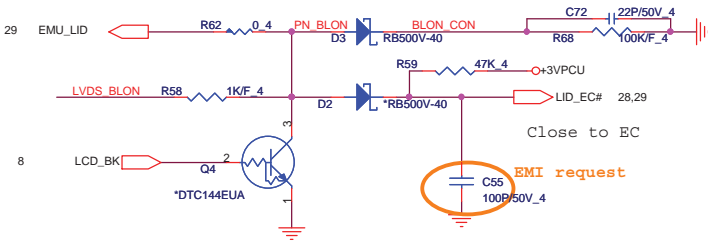

Please note that 2011 camera is +3V as we do not need to use 5V -> 3.95V regulator!

change to +5VS5

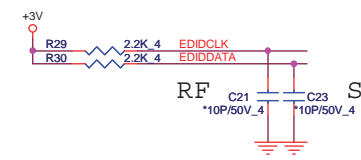
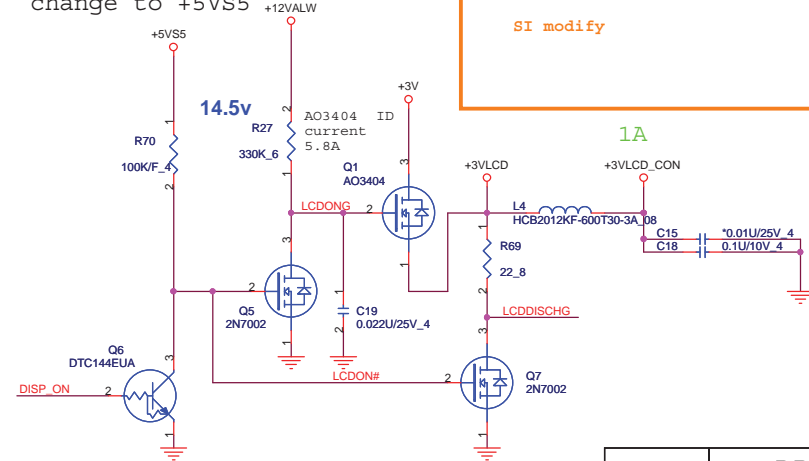

SI change to AX type

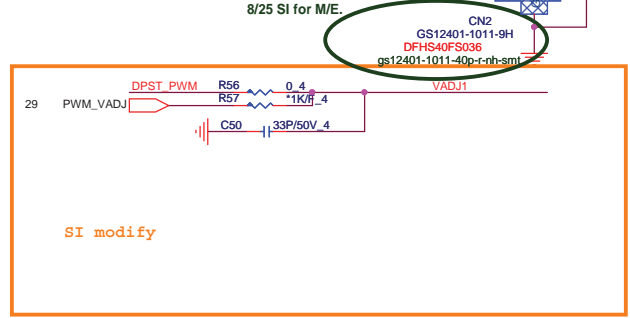
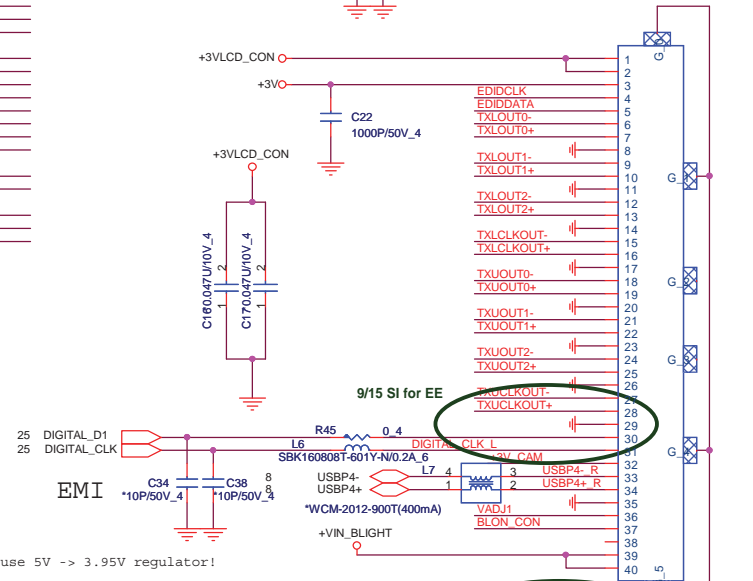

SI modify

1A



<http://laptop-motherboard-schematic.blogspot.com>



PROJECT : R13
Quanta Computer Inc.

Size Custom	Document Number LCD CONN/LID/CAM	Rev 3A
Date: Saturday, September 18, 2010		Sheet 20 of 39

close to HDMI conn

6	IN_CLK#	IN_CLK#	C290	0.1U/10V_4	C_TXC_HDMI-
6	IN_CLK	IN_CLK	C298	0.1U/10V_4	C_TXC_HDMI+
6	IN_DO#	IN_DO#	C307	0.1U/10V_4	C_TX0_HDMI-
6	IN_DO	IN_DO	C309	0.1U/10V_4	C_TX0_HDMI+
6	IN_D1#	IN_D1#	C298	0.1U/10V_4	C_TX1_HDMI-
6	IN_D1	IN_D1	C303	0.1U/10V_4	C_TX1_HDMI+
6	IN_D2#	IN_D2#	C313	0.1U/10V_4	C_TX2_HDMI-
6	IN_D2	IN_D2	C314	0.1U/10V_4	C_TX2_HDMI+



DISCRETE HDMI I2C SELECT Close to HDMI Connector

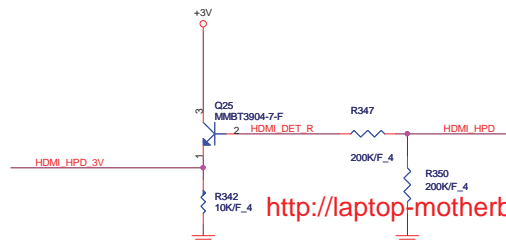
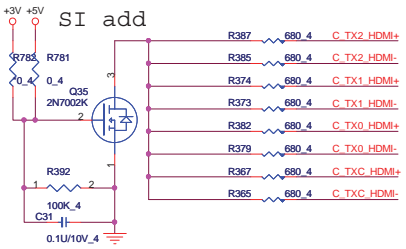
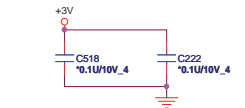
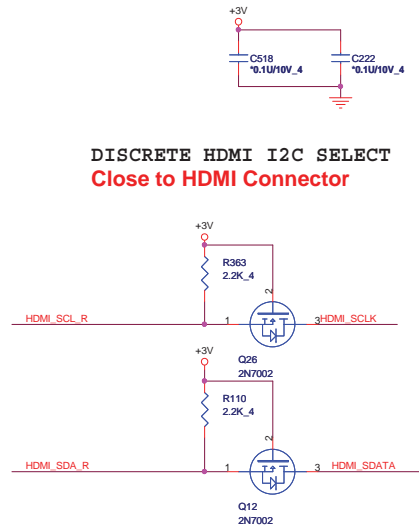

<http://laptop-motherboard-schematic.blogspot.com/>

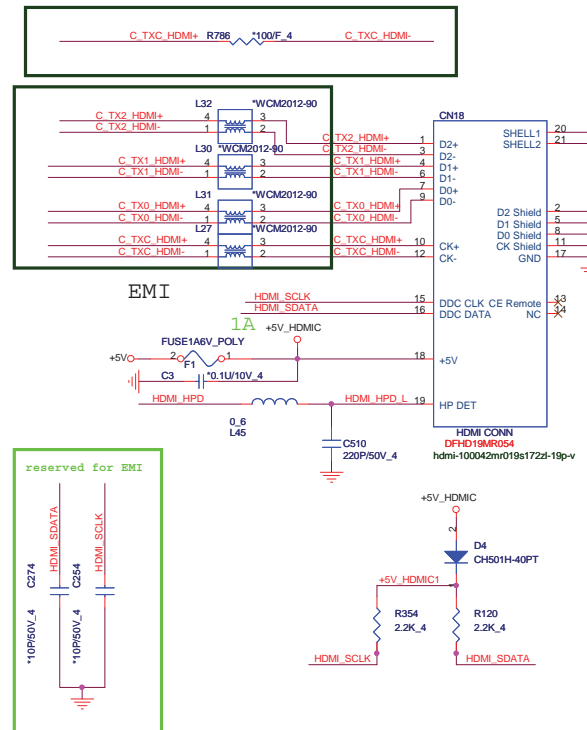

PROJECT : R13
Quanta Computer Inc.

NB5

Size Custom Document Number **HDMI CONN** Rev 3A

Date: Saturday, September 18, 2010 Sheet 21 of 38

CRT PORT

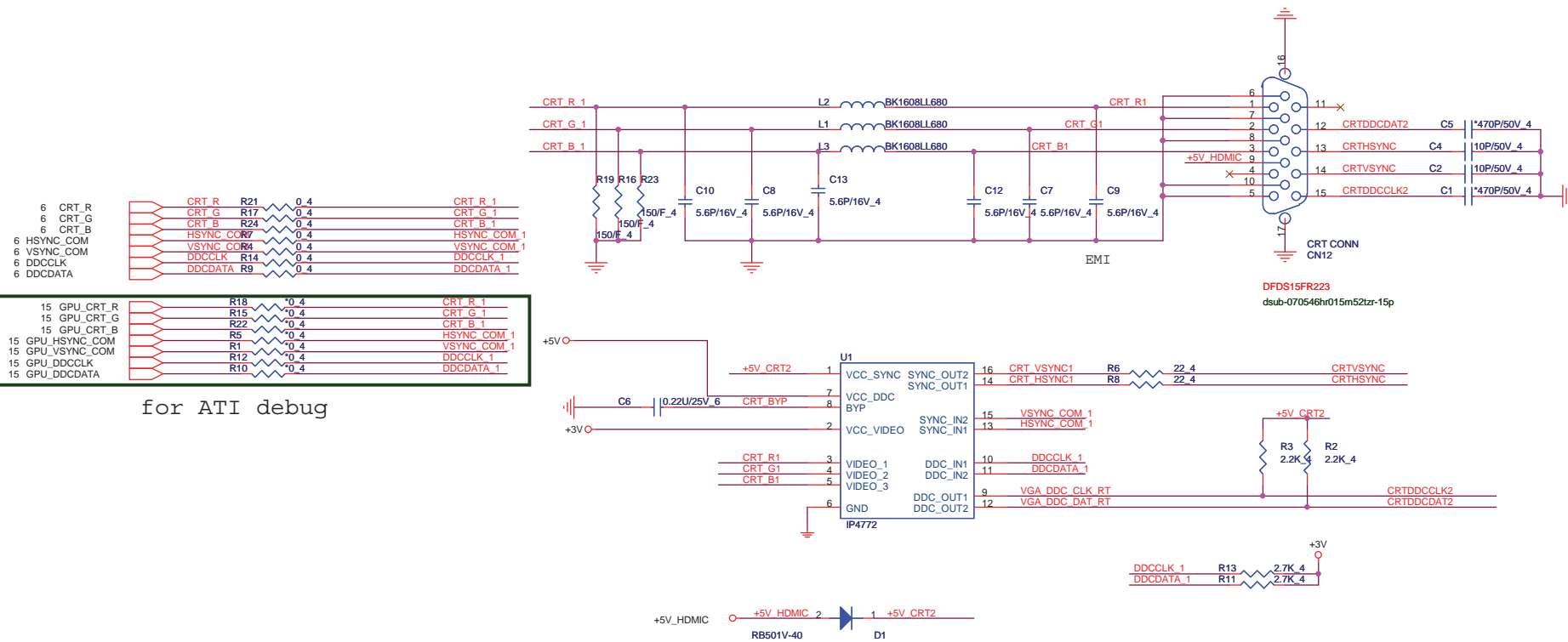

HOLE

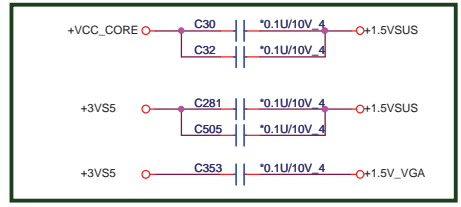
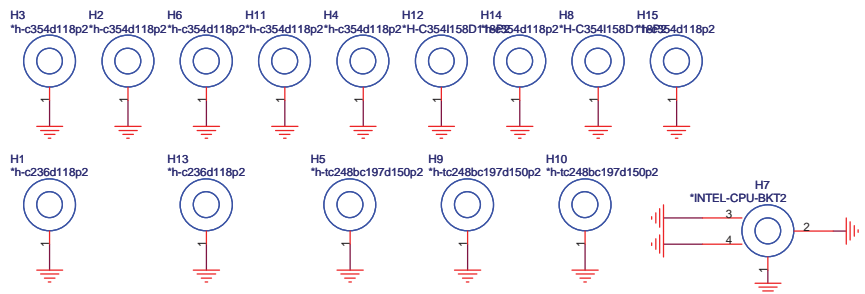

RF solution

<http://laptop-motherboard-schematic.blogspot.com/>

	PROJECT : R13	
	Quanta Computer Inc.	
Size Custom	Document Number CRT,Hole	Rev 3A
Date: Saturday, September 18, 2010	Sheet 22	of 39

CPU FAN

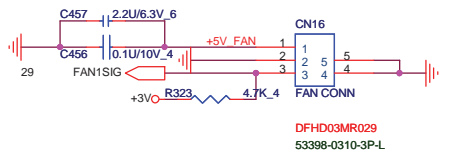

DFHD03MR029
53398-0310-3P-L

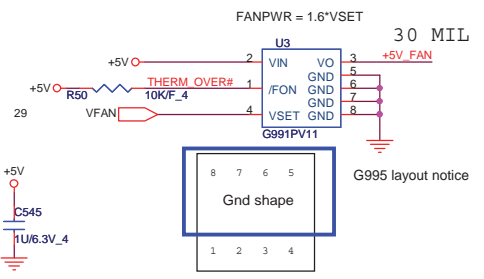

G995 layout notice

SATA HDD CONNECTOR

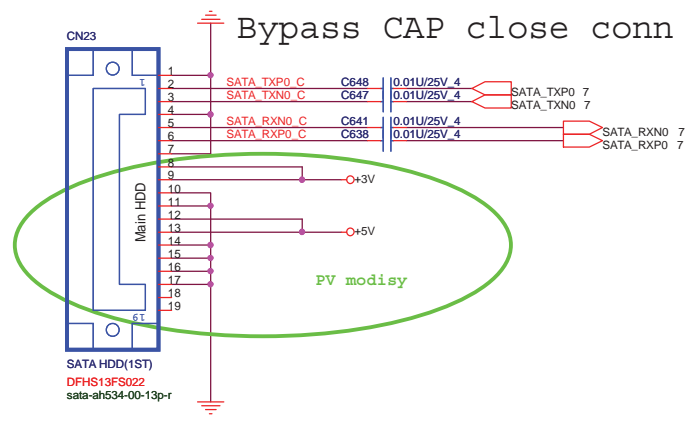

Bypass CAP close conn

SATA HDD(1ST)
DFHS13FS022
sata-ah534-00-13p-r

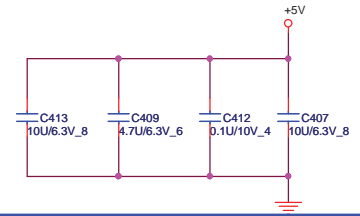

SATA ODD CONNECTOR

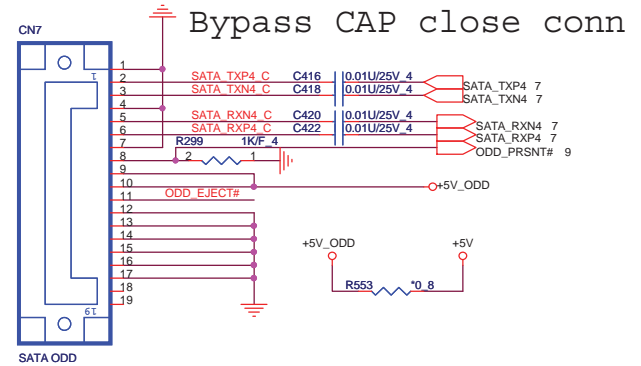

Bypass CAP close conn

DFHS13FS022
sata-ah534-00-13p-r

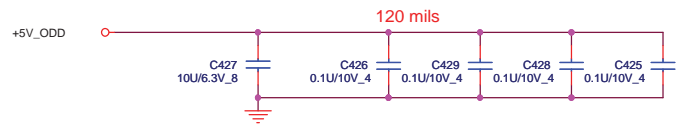

follow INTEL DG change eject PU to +3V.

High : ODD power down
Low : ODD power on

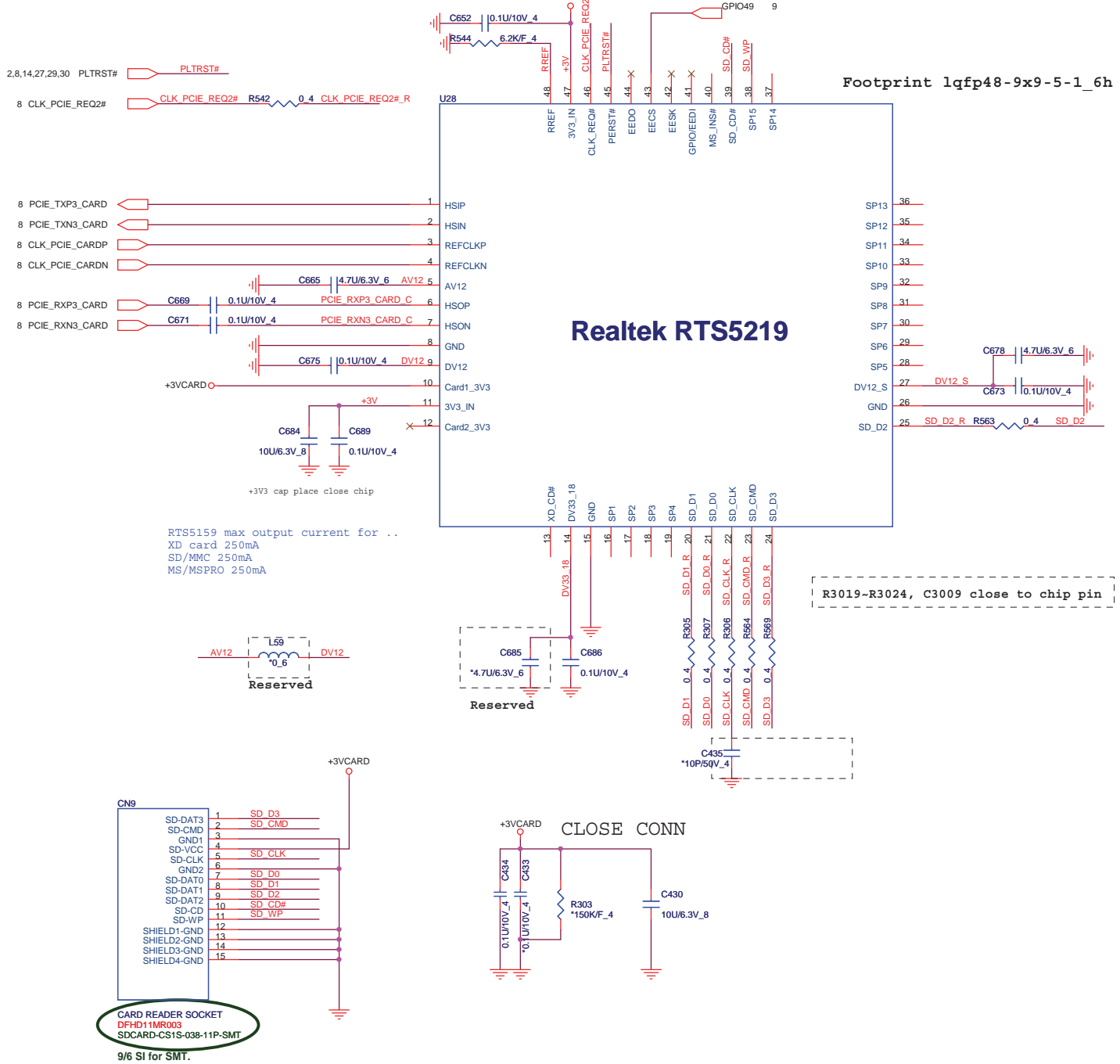

	PROJECT : R13		
	Quanta Computer Inc.		
	Size Custom	Document Number	Rev 3A
RTS5219 & CR SOCKET & HOLE		Date: Saturday, September 18, 2010	Sheet 24 of 39

BLUETOOTH

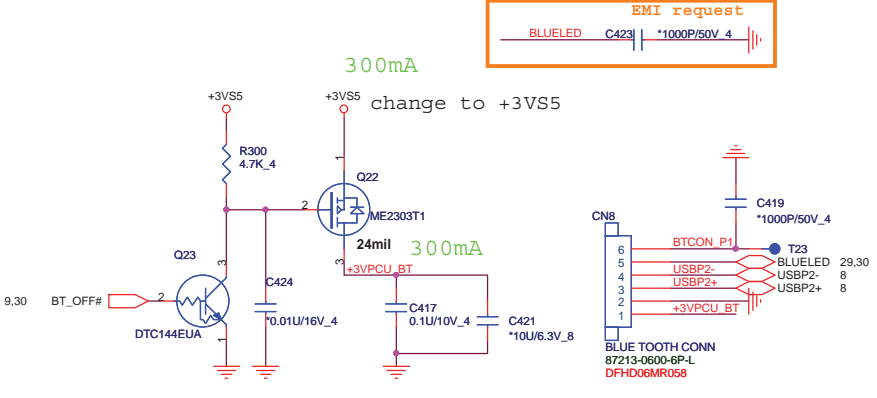

LEFT SIDE USB2

change to AL000547005

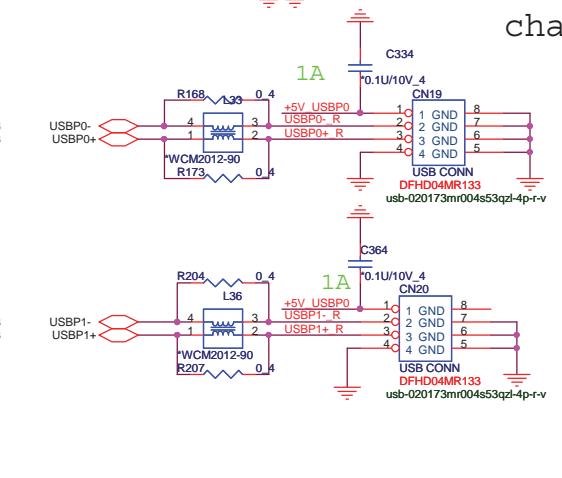
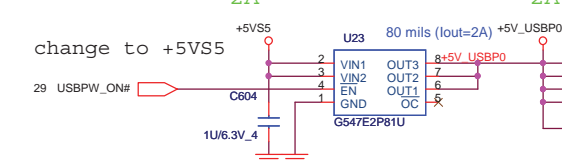

change to ELEC CAP

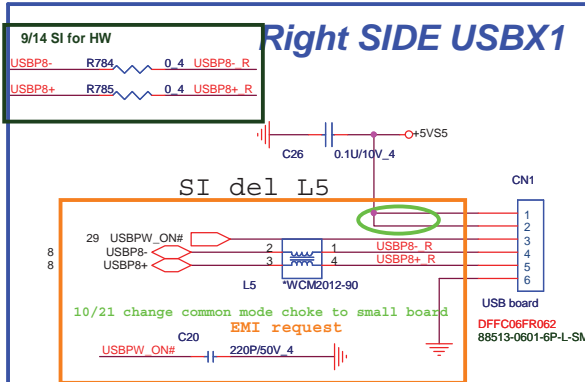

Line out

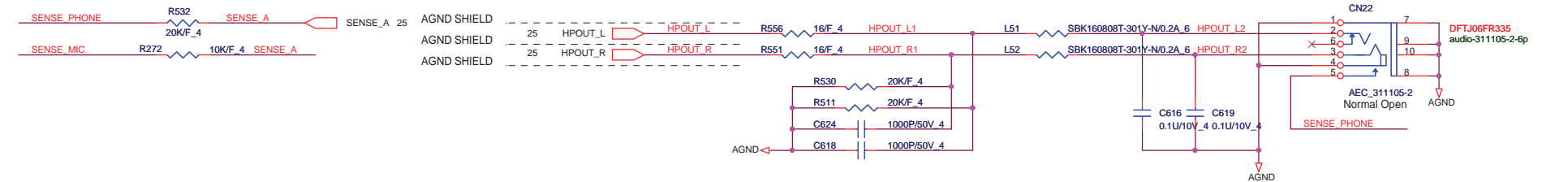

MIC

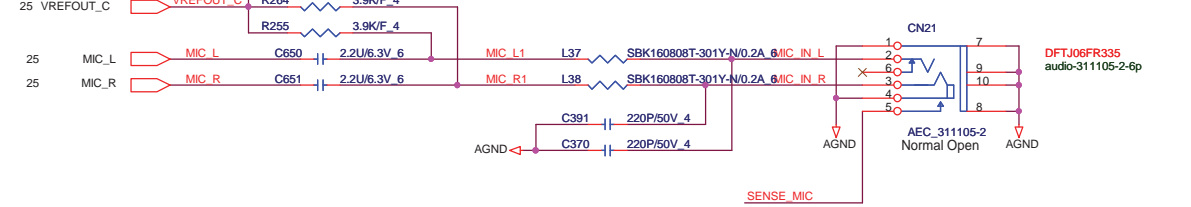

PROJECT : R13
Quanta Computer Inc.

Size Custom Document Number **USB/BT/Audio Jack** Rev 3A

Date: Saturday, September 18, 2010 Sheet 26 of 39

POWER BOTTON CONNECT

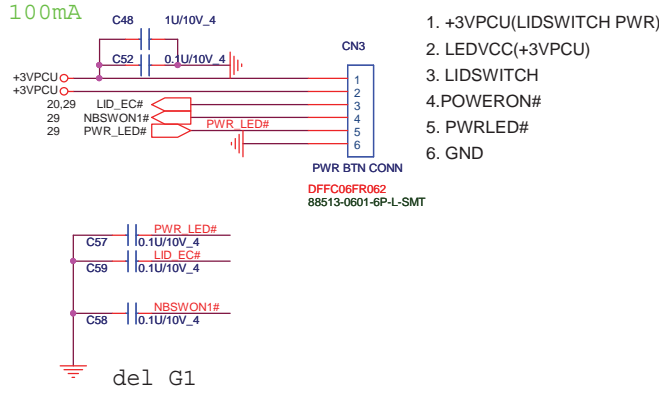

KEYBOARD Con.

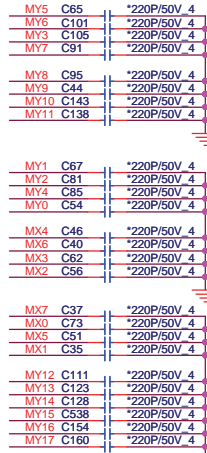

SI un-install

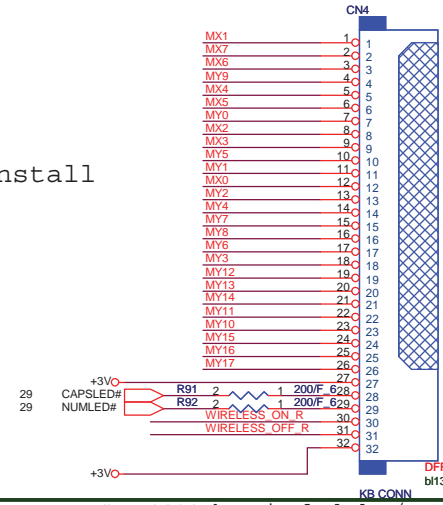

KEYBOARD PULL-UP

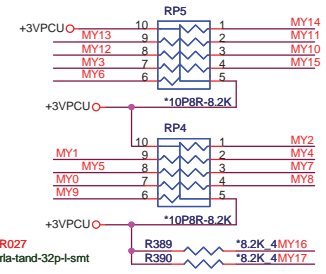

EC KB3930 has included K/B pull-up resistor and function

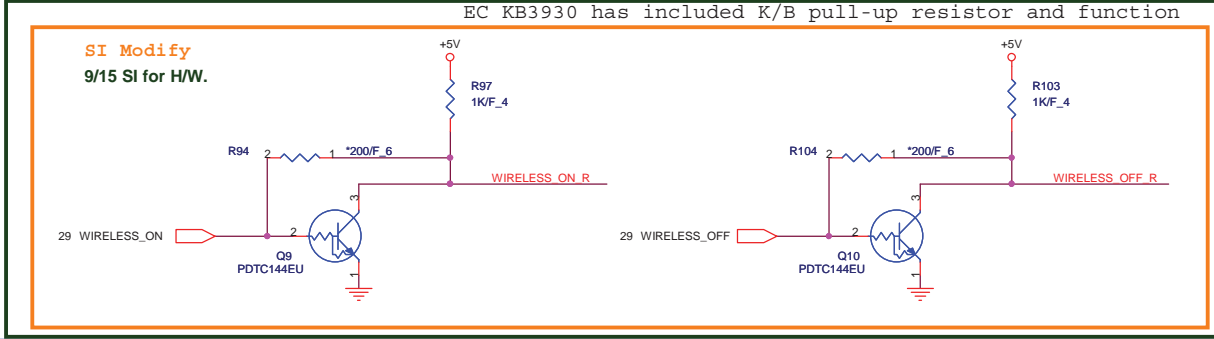

LED Con.

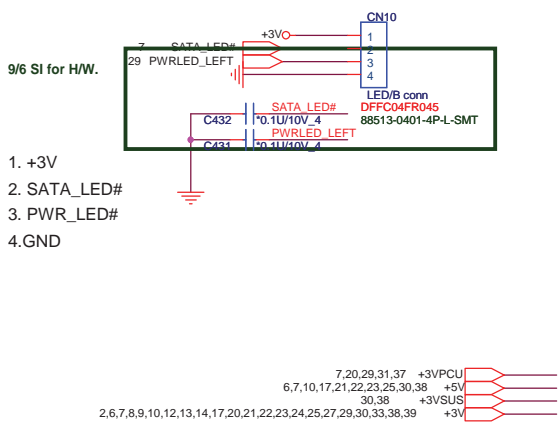

TOUCH PAD Con.

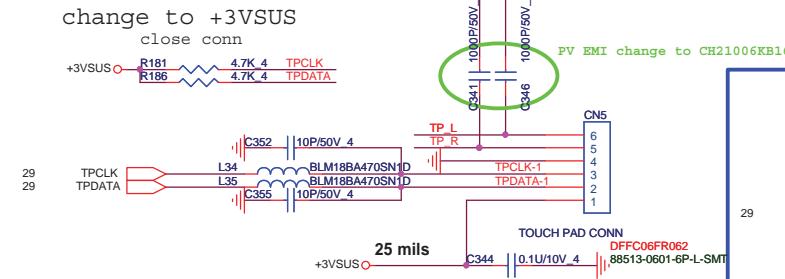

To TOUCH PAD SW board

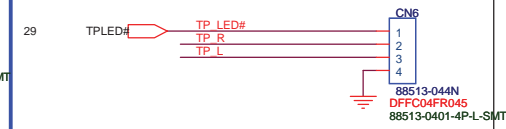

PROJECT : R13
 Quanta Computer Inc.

Size Custom Document Number LED/KB/SW/TP Rev 3A
 Date: Saturday, September 18, 2010 Sheet 28 of 39

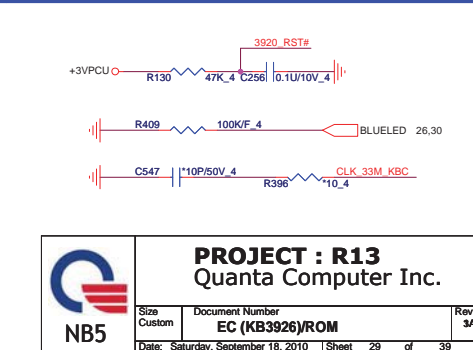
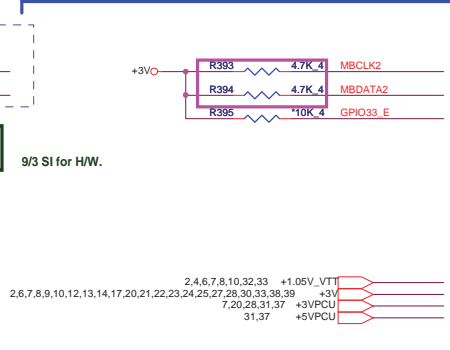
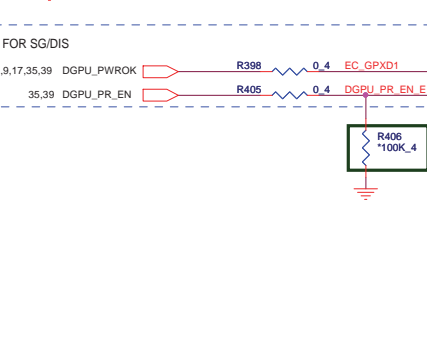
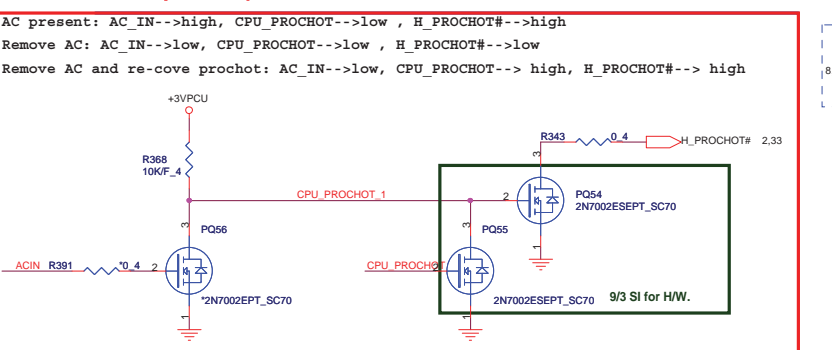
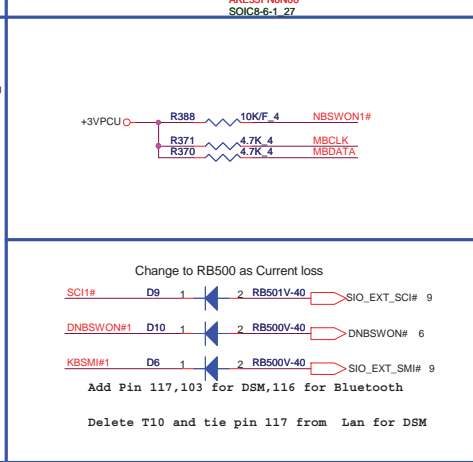
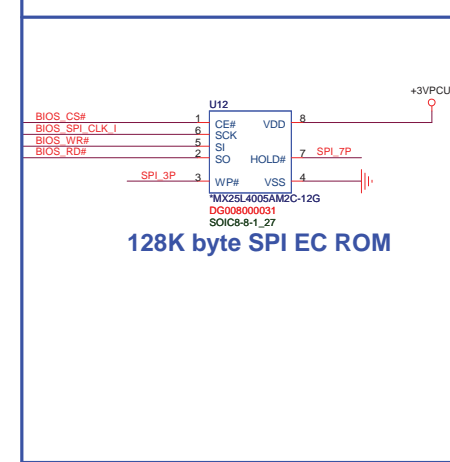
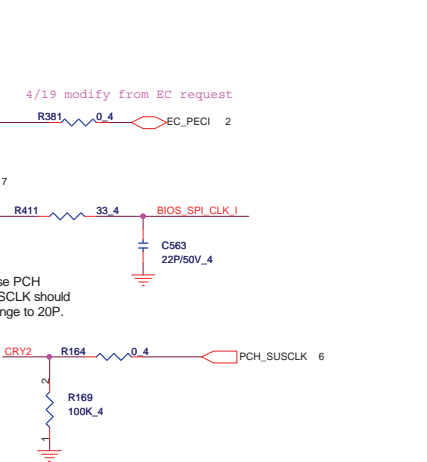
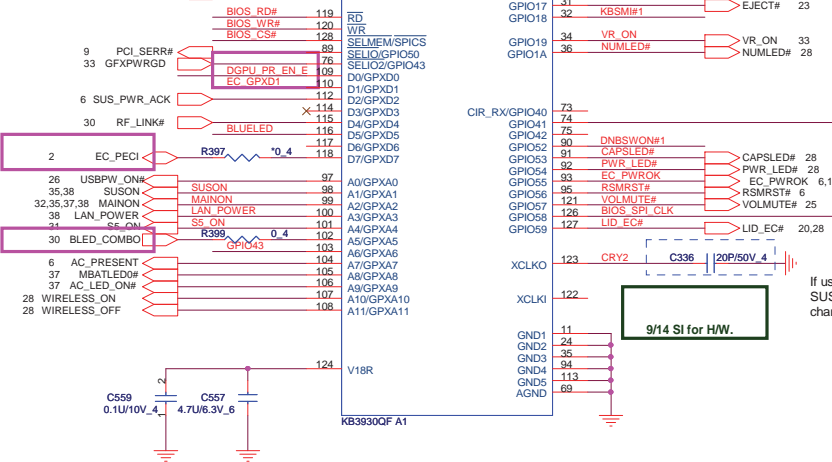
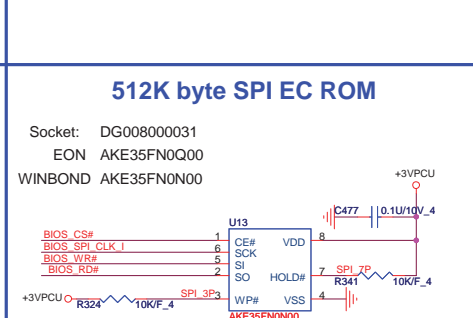
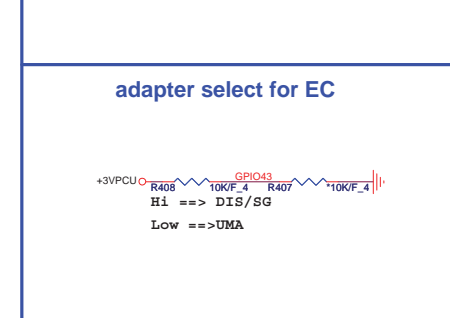
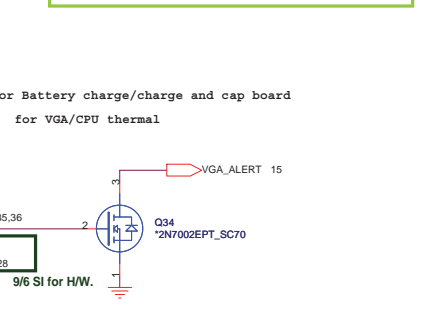
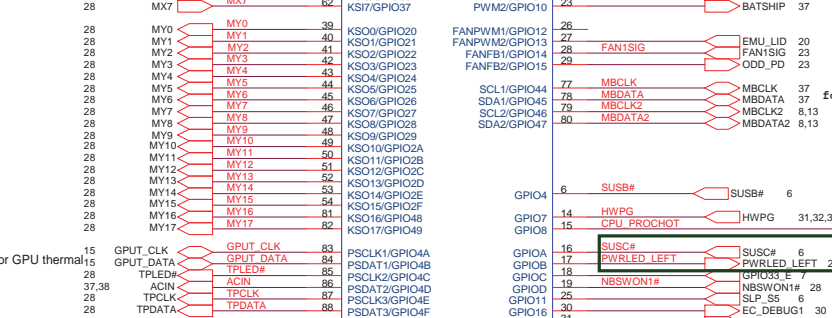
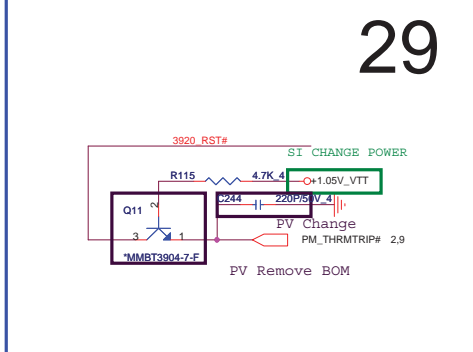
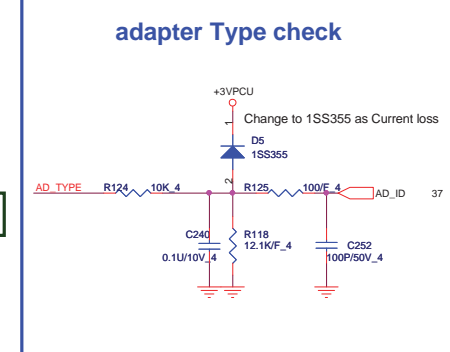
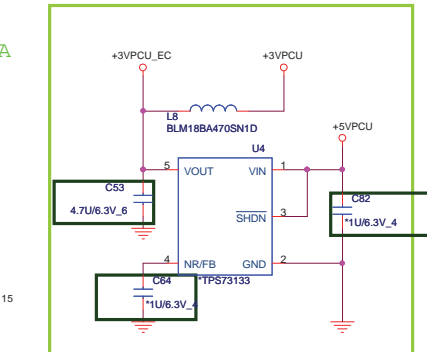
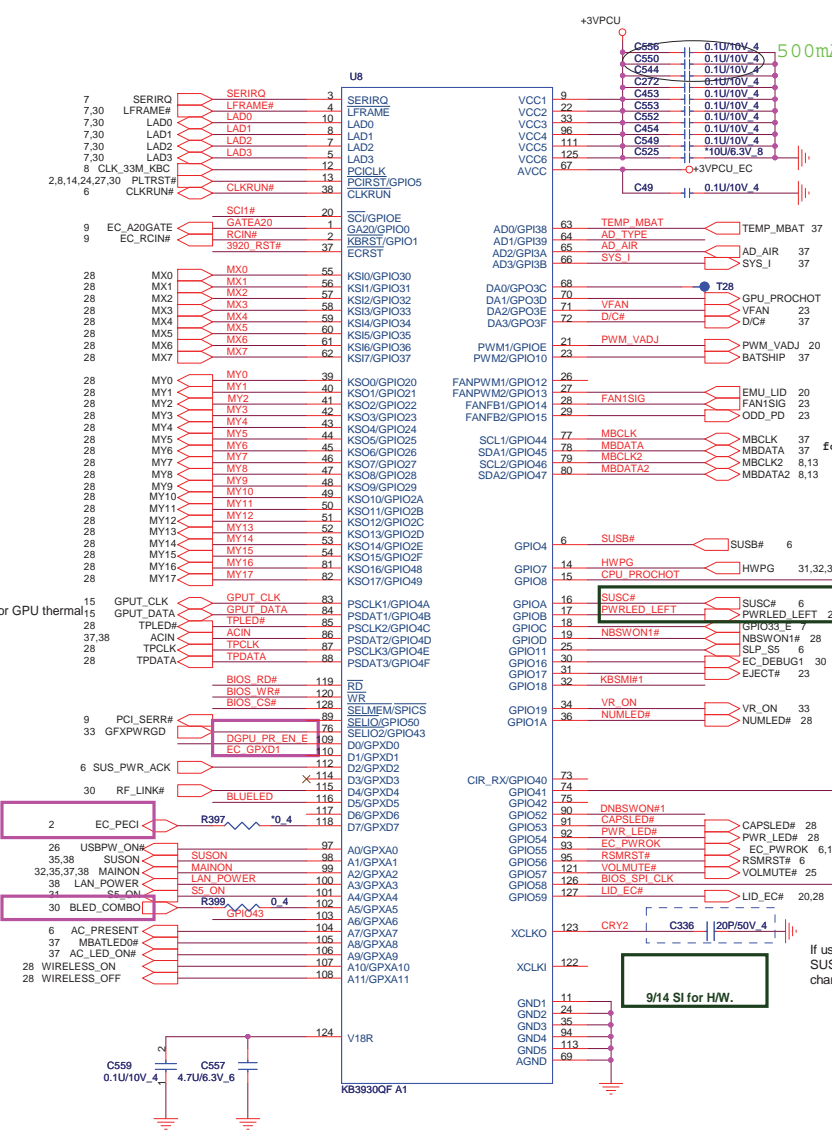

Mini PCI-E Card 1 WLAN

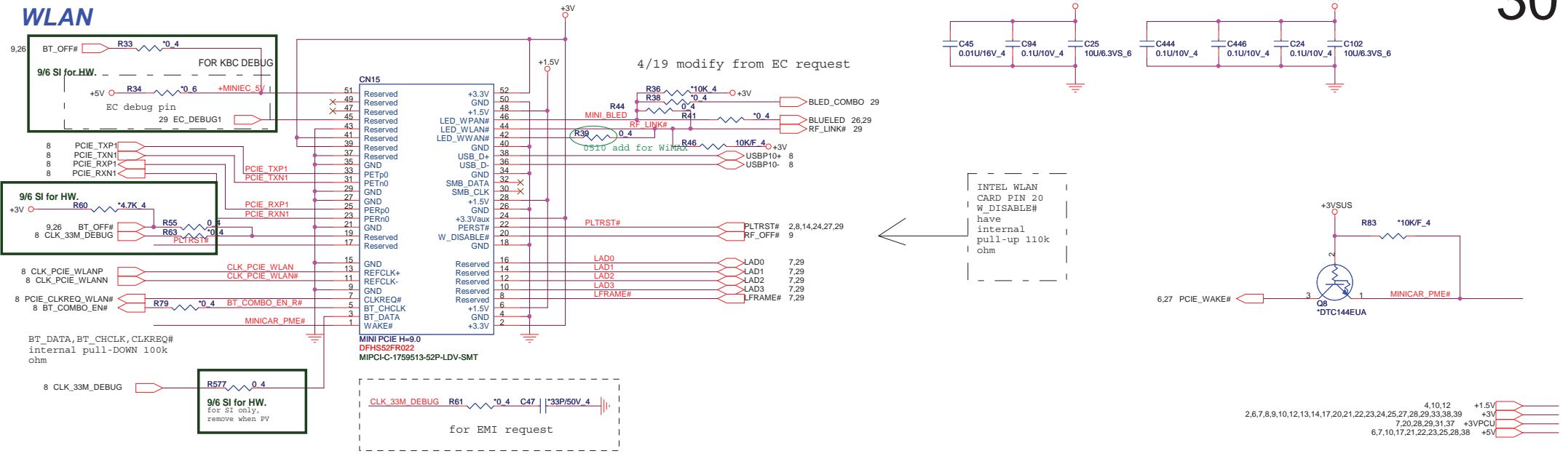

	PROJECT : R13 Quanta Computer Inc.		
	Size Custom	Document Number MINI PCI-E CONN X1	Rev 3A
	Date: Saturday, September 18, 2010 Sheet 30 of 39		

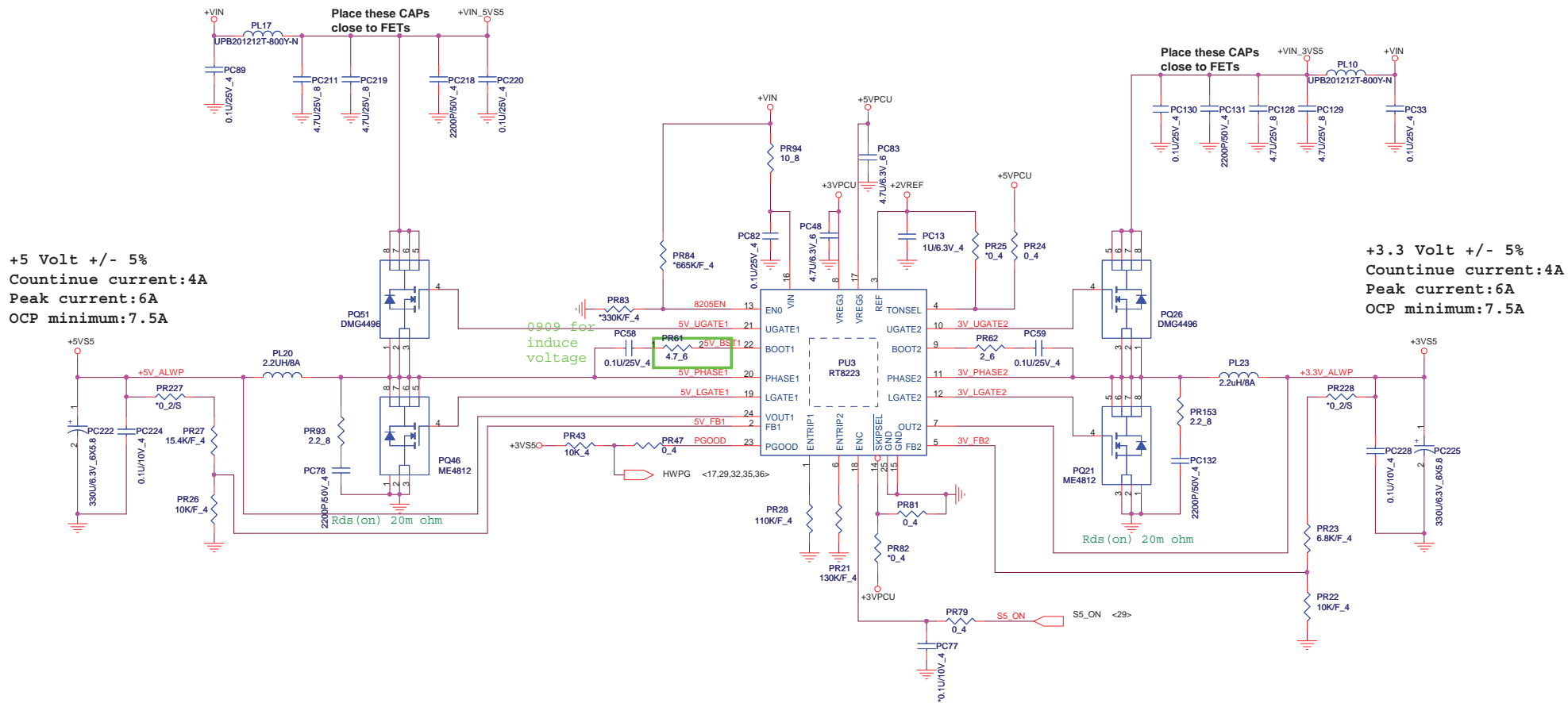

	PROJECT : R13		Rev 3A
	Quanta Computer Inc.		
	Size Custom	Document Number +5V/+3V (RT8206B)	
Date: Saturday, September 18, 2010		Sheet 31 of 39	

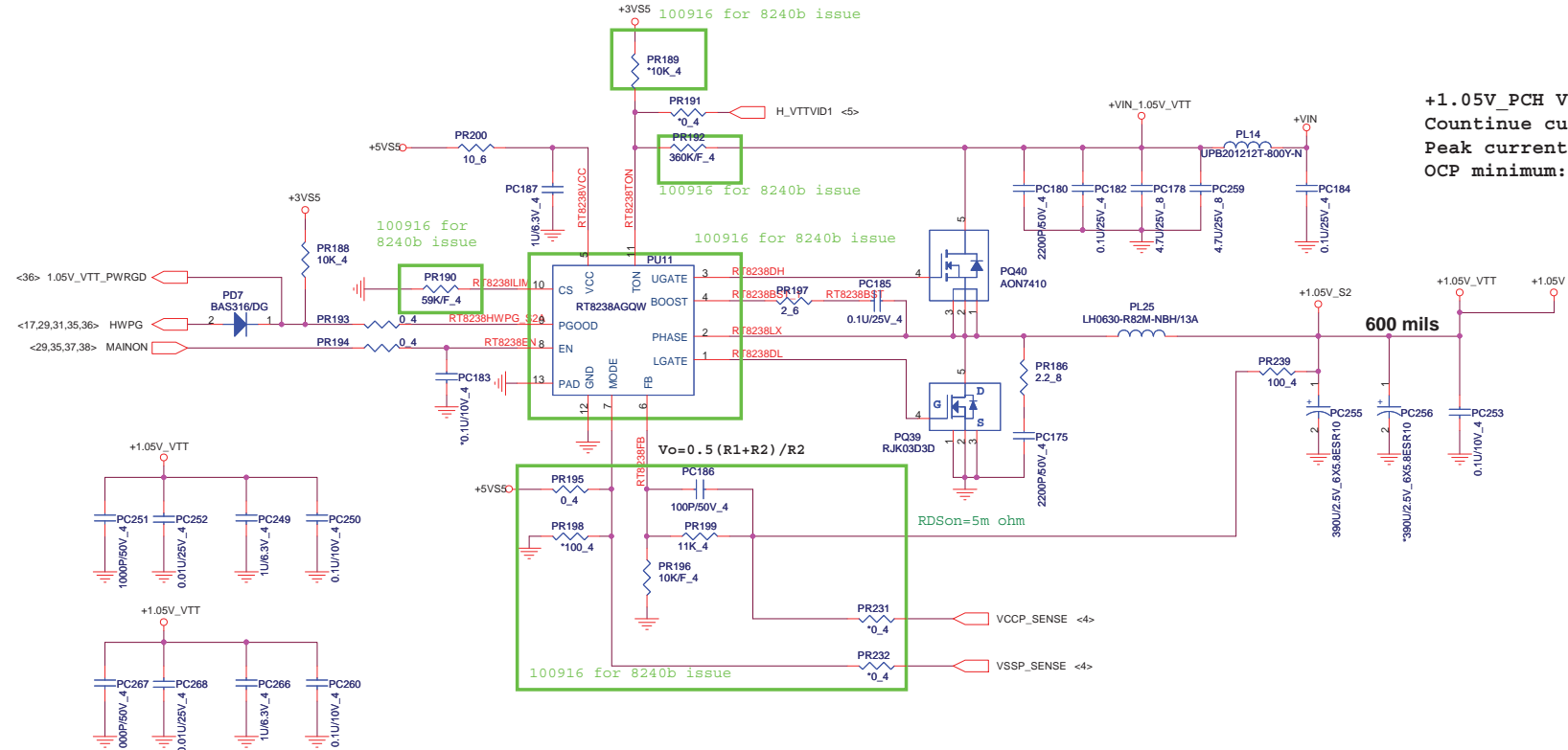

+1.05V_PCH Volt +/- 5%
 Countinue current:10A
 Peak current: 12A
 OCP minimum: 14.5A

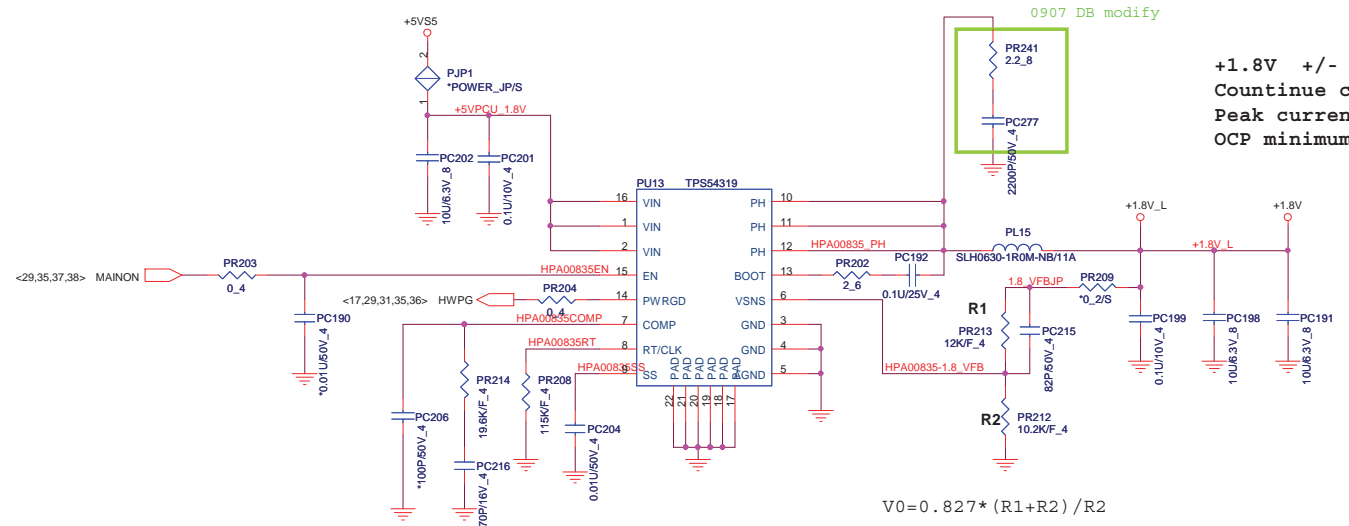
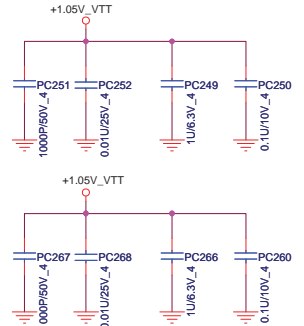

+1.8V +/- 5%
 Countinue current:1.5A
 Peak current:2.5A
 OCP minimum 4A

$$V0 = 0.827 * (R1 + R2) / R2$$

	PROJECT : R13		Rev 3A
	Quanta Computer Inc.		
	Size Custom	Document Number +1.1V VTT / PCH	

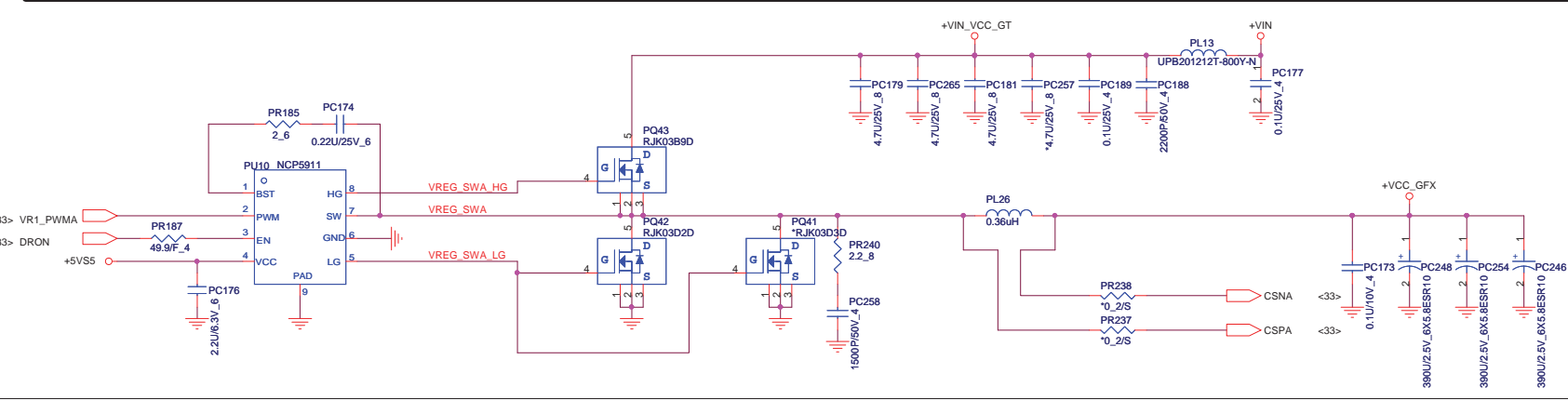
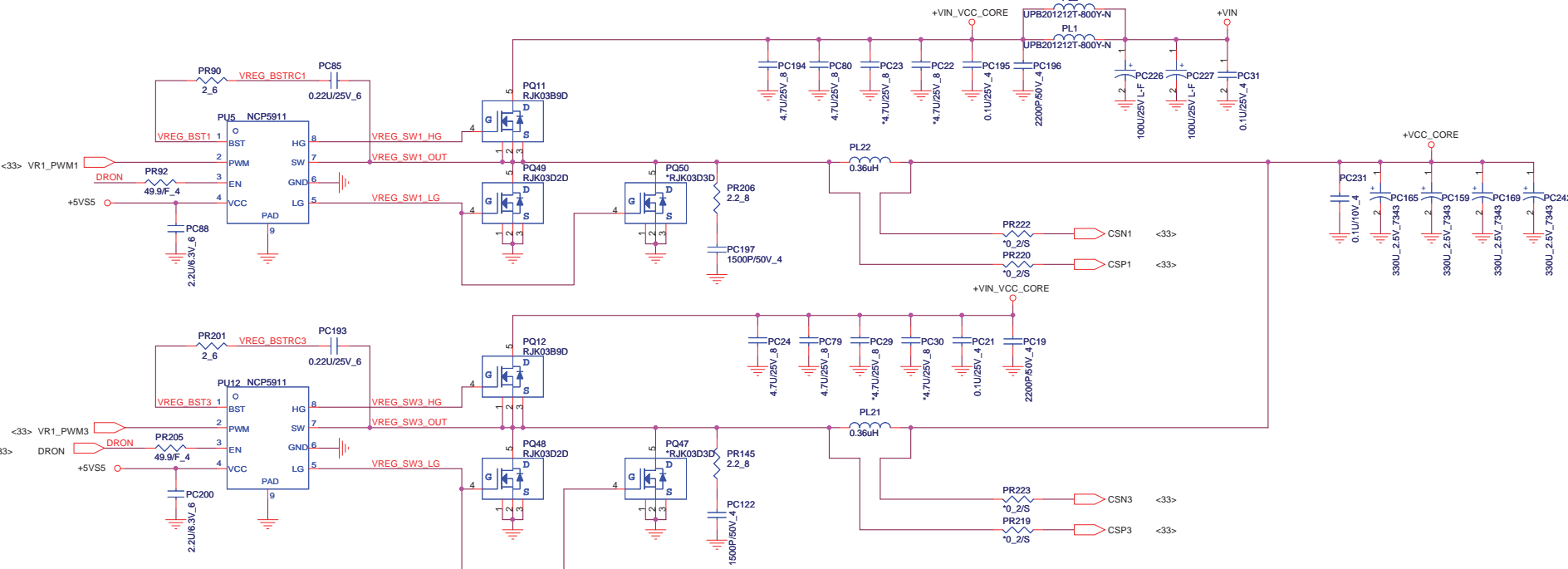

 NB5	PROJECT : R13		Rev 3A
	Quanta Computer Inc.		
Size Custom	Document Number CPU Core2 (NCP5911)	Date: Saturday, September 18, 2010 Sheet 34 of 39	

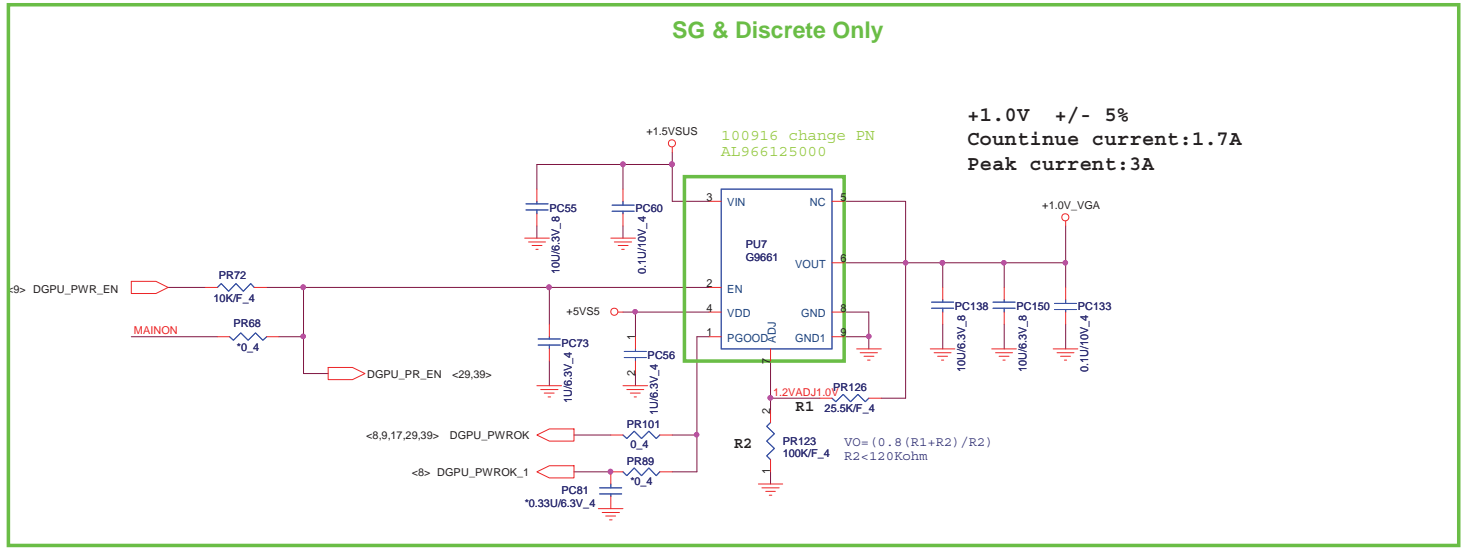
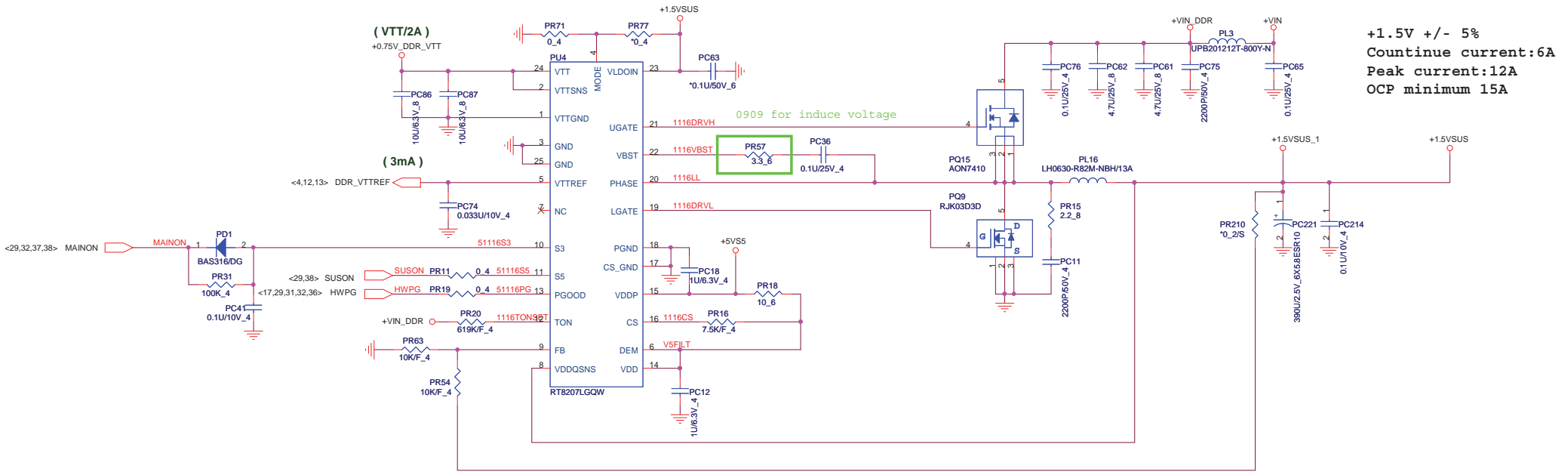

	PROJECT : R13		Rev 3A
	Quanta Computer Inc.		
	Size Custom	Document Number DDR3 (RT8207)	
Date: Saturday, September 18, 2010 Sheet 35 of 39			

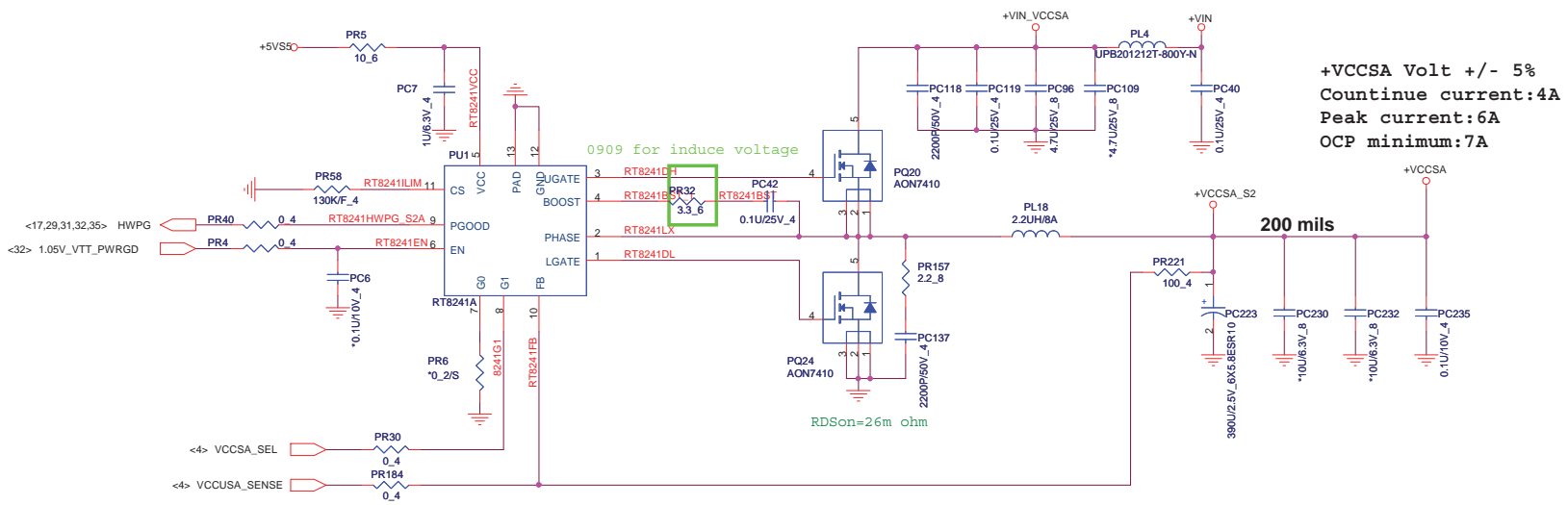

+VCCSA Volt +/- 5%
 Countinue current:4A
 Peak current:6A
 OCP minimum:7A

200 mils

RDSon=26m ohm

0909 for induce voltage

	PROJECT : R13		Rev 3A
	Quanta Computer Inc.		
	Size Custom	Document Number +1.1V VTT / PCH	
Date: Saturday, September 18, 2010		Sheet 36 of 39	

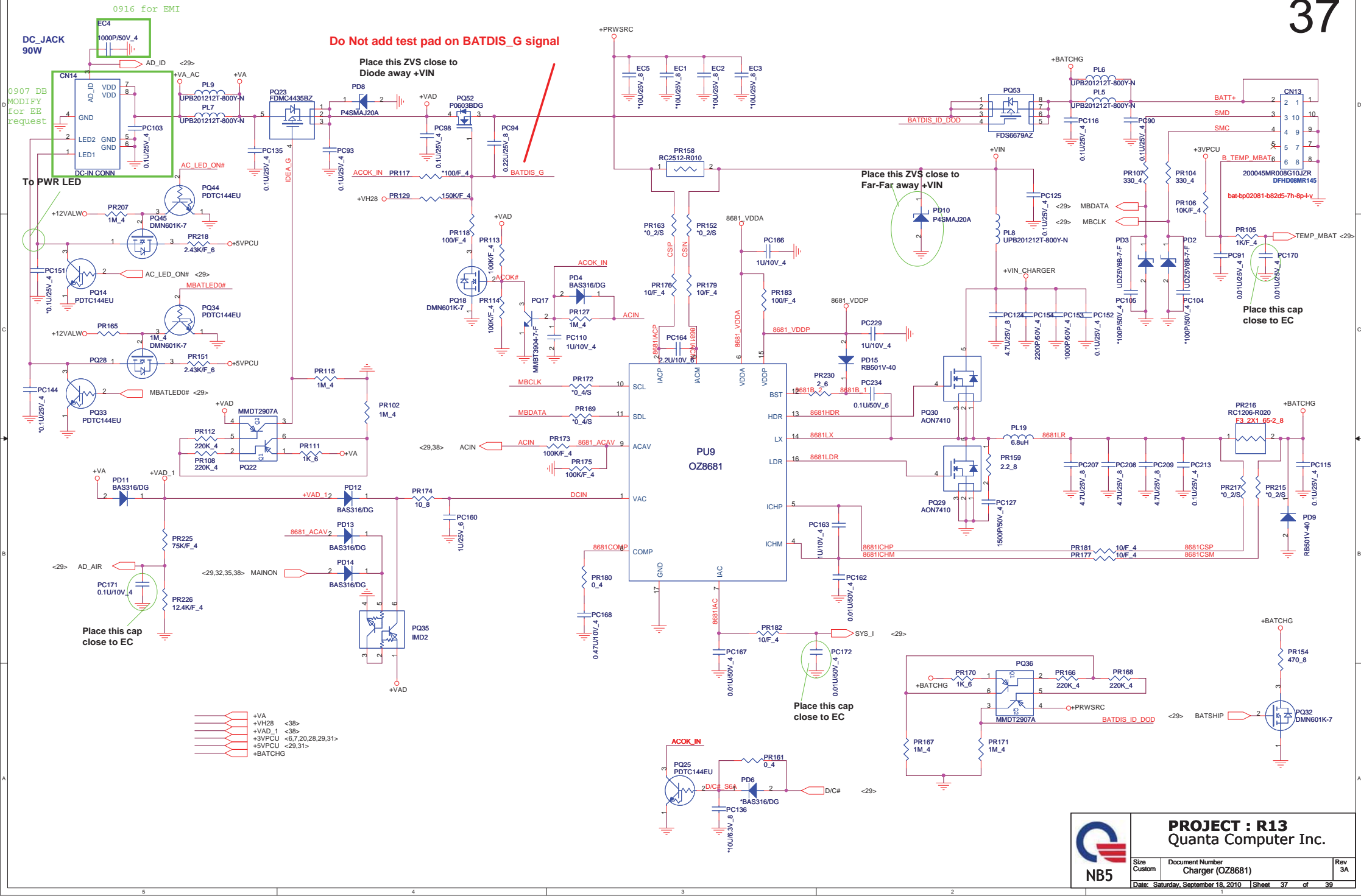

Do Not add test pad on BATDIS_G signal

Place this ZVS close to Diode away +VIN

Place this ZVS close to Far-Far away +VIN

Place this cap close to EC

Place this cap close to EC

Place this cap close to EC

- +VA
- +VH28 <38>
- +VAD_1 <38>
- +3VPCU <6,7,20,28,29,31>
- +5VPCU <29,31>
- +BATCHG

	PROJECT : R13	
	Quanta Computer Inc.	
	Size Custom	Document Number Charger (OZ8681)
Date: Saturday, September 18, 2010 Sheet 37 of 39		

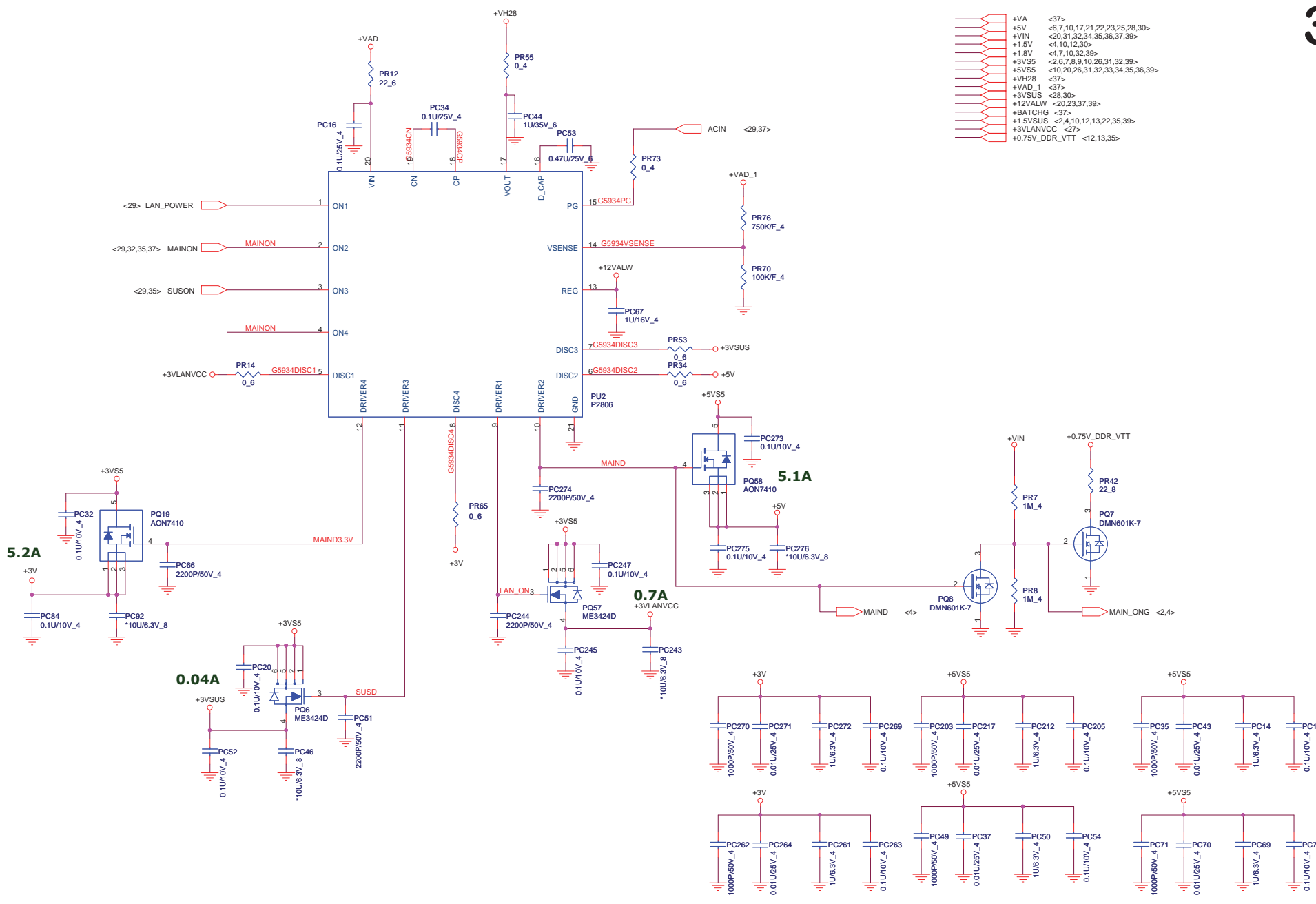

- +VA <37>
- +5V <6,7,10,17,21,22,23,25,28,30>
- +VIN <20,31,32,34,35,36,37,39>
- +1.5V <4,10,12,30>
- +1.8V <4,7,10,32,39>
- +3VS5 <2,6,7,8,9,10,26,31,32,39>
- +5VS5 <10,20,26,31,32,33,34,35,36,39>
- +VH28 <37>
- +VAD_1 <37>
- +3VSUS <28,30>
- +12VALW <20,23,37,39>
- +BATCHG <37>
- +1.5VSUS <2,4,10,12,13,22,35,39>
- +3VLANVCC <27>
- +0.75V_DDR_VTT <12,13,35>

	PROJECT : R13	
	Quanta Computer Inc.	
Size Custom	Document Number Dis-charge IC (G5934)	Rev 3A
Date: Saturday, September 18, 2010 Sheet 38 of 39		

+VGACORE +/- 5%
Countinue current:10A
Peak current:14A
OCp minimum 16A

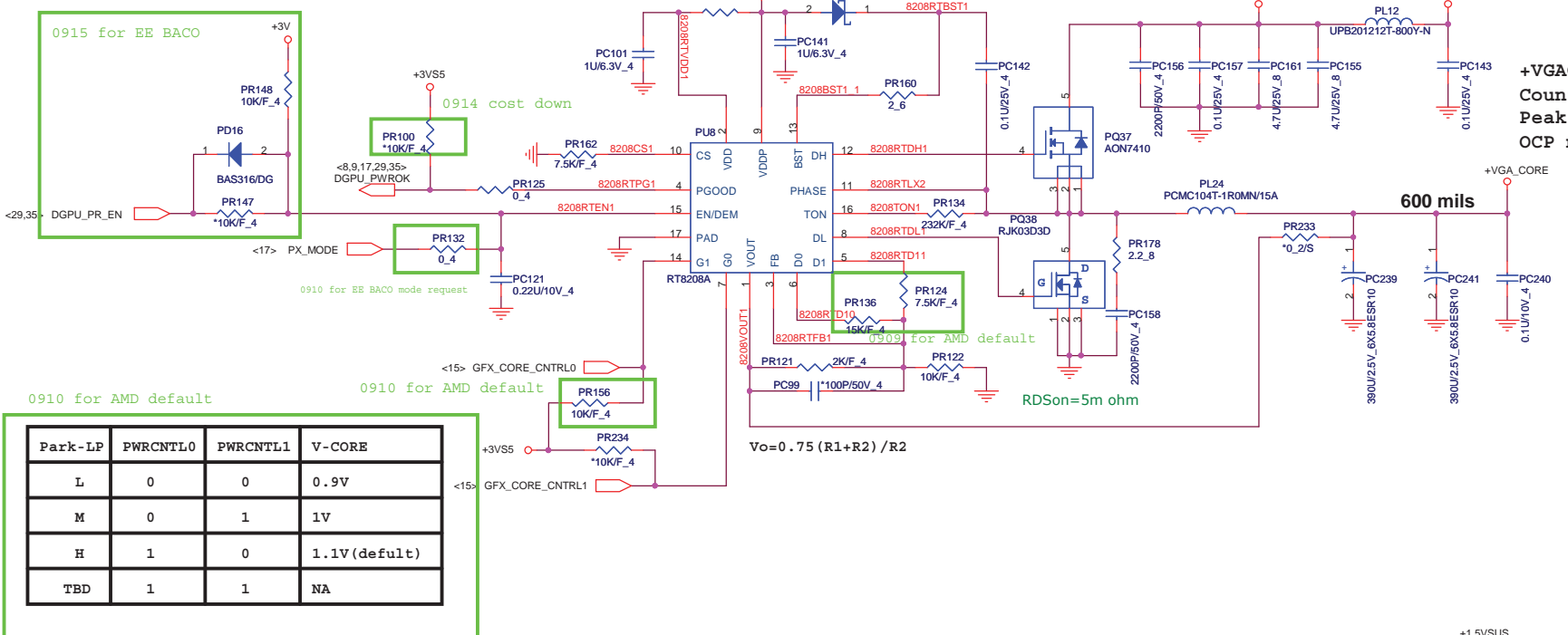

0910 for AMD default

Park-LP	PWRCNTL0	PWRCNTL1	V-CORE
L	0	0	0.9V
M	0	1	1V
H	1	0	1.1V (default)
TBD	1	1	NA

