

Miata2.0 (NM3) Block Diagram

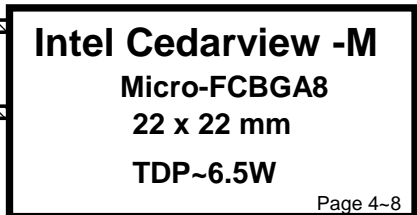

PCB STACK UP 6L

- LAYER 1 : TOP
- LAYER 2 : SGND
- LAYER 3 : IN1
- LAYER 4 : IN2
- LAYER 5 : VCC
- LAYER 6 : BOT

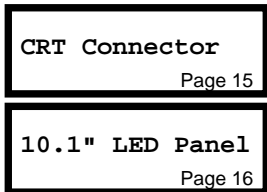

DDR3 1066MT/s (Single Channel)

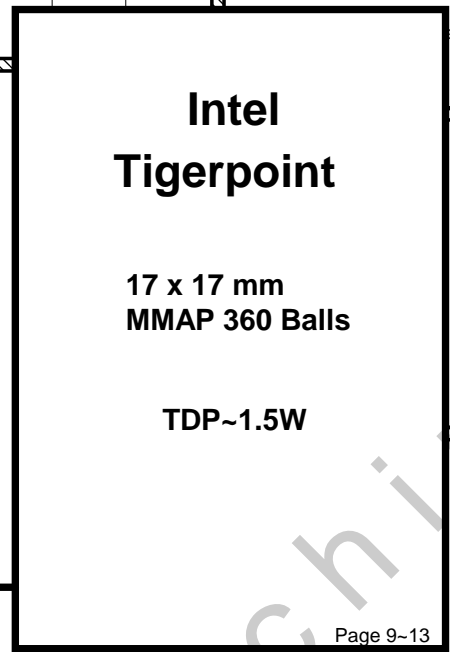
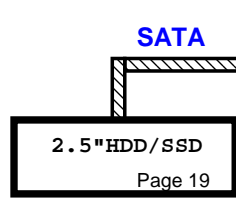
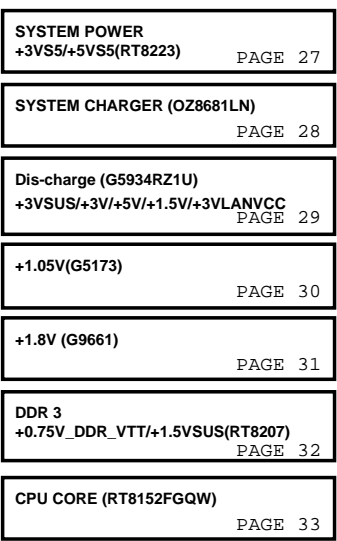
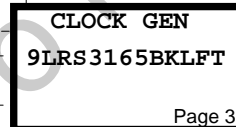
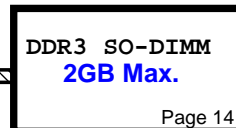

32.768KHz
DMI x2
CLK_PCI_DMI,CLK_PCI_DMI#
HCLK_CPU,HCLK_CPU#; HCLK_MCH,HCLK_MCH#
DREFSSCLK,DREFSSCLK#; DREFCLK,DREFCLK#
CLK_PCIE_ICH,CLK_PCIE_ICH#,CLK_USB_48,CLK14M_ICH
CLK_PCIE_SATA,CLK_PCIE_SATA#,PCLK_ICH

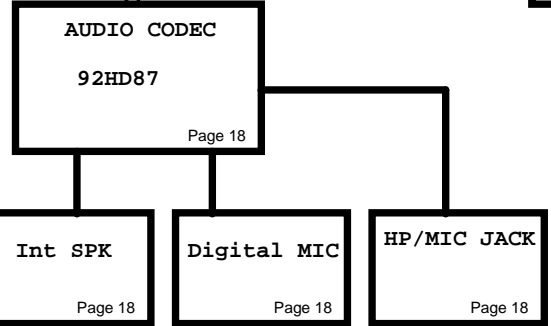
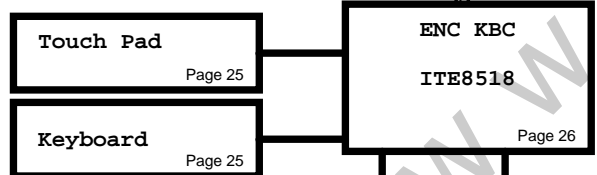
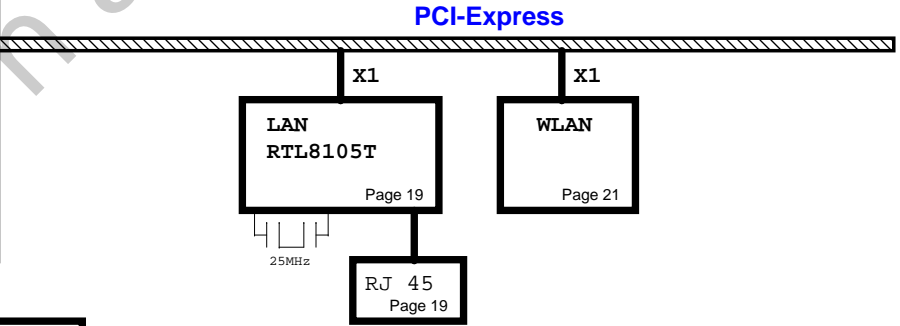
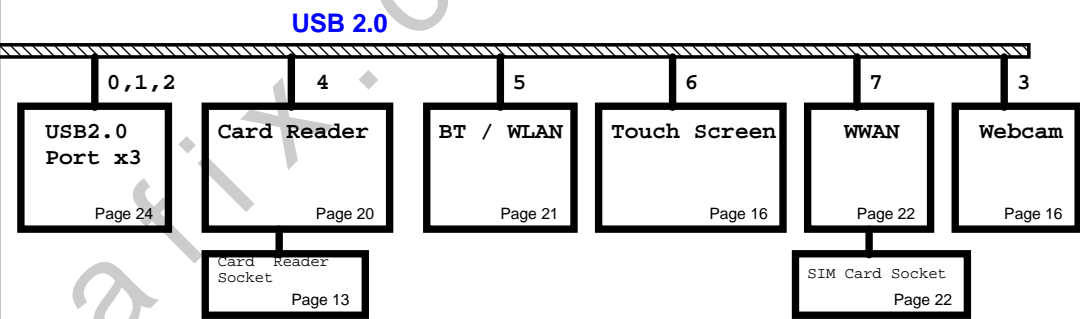

Quanta Computer Inc.
PROJECT : Miata (NM3)

Size	Document Number	Rev
	Block Diagram	1A
Date:	Thursday, April 07, 2011	Sheet 1 of 32

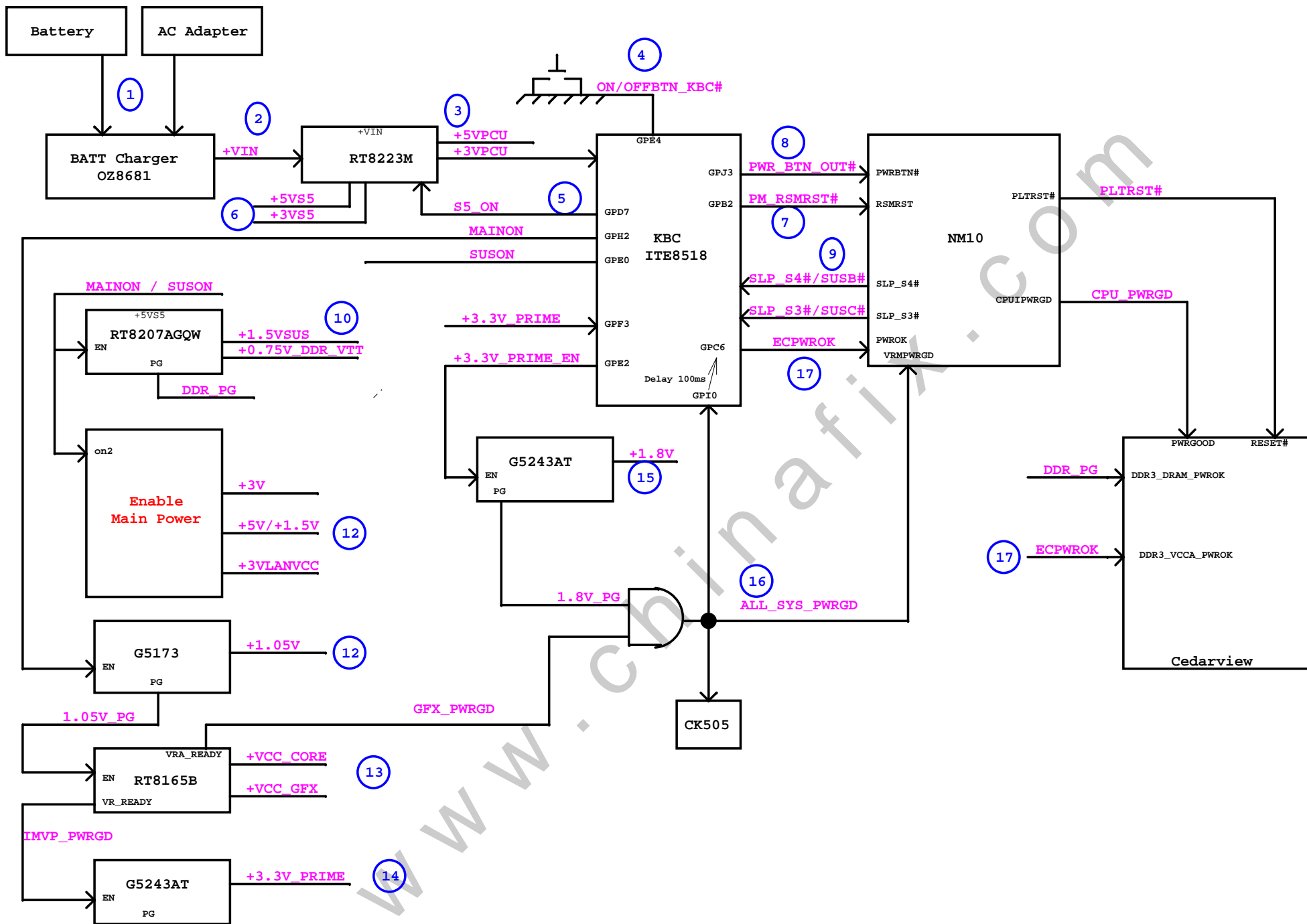

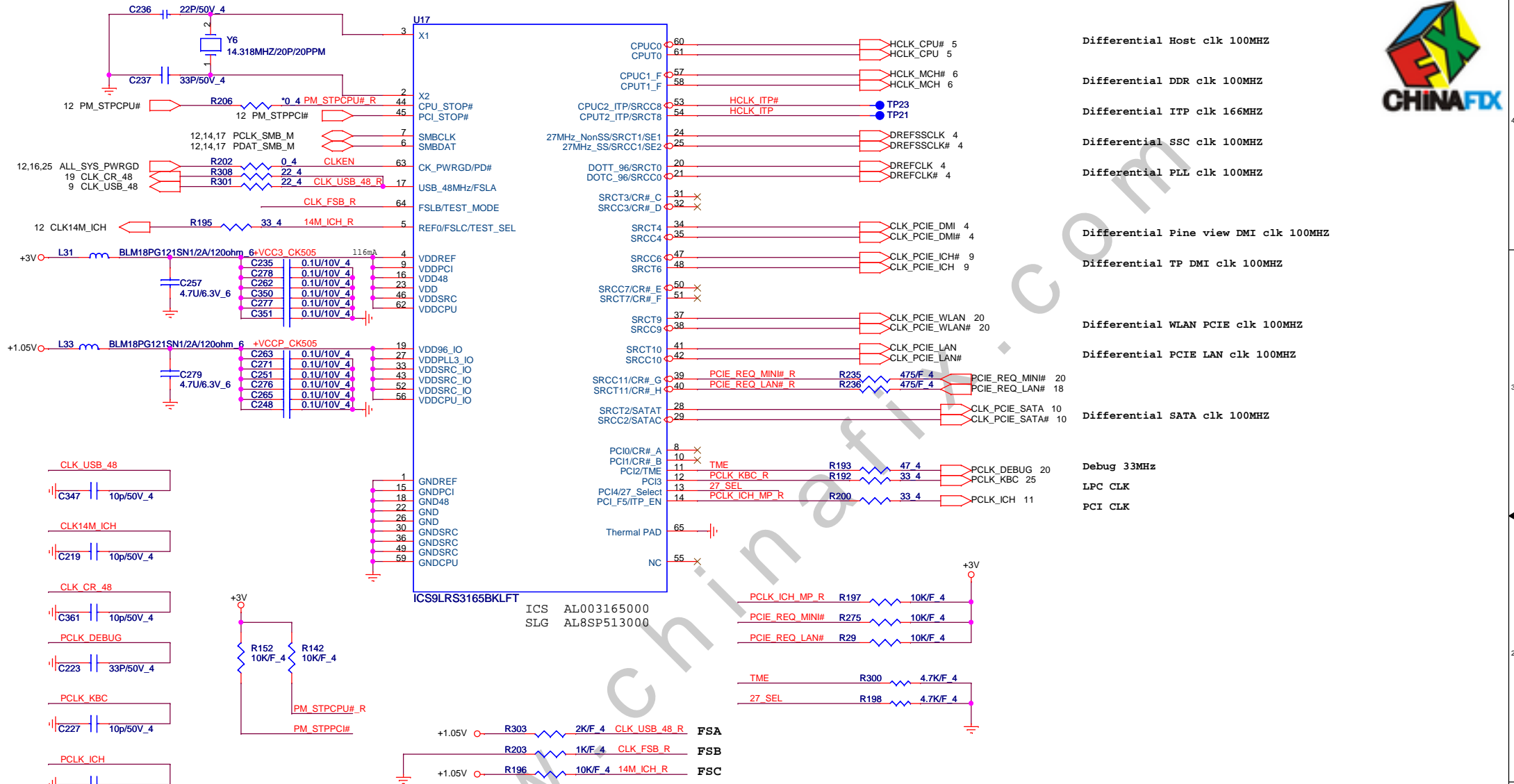

FSC	FSB	FSA	CPU	SRC	PCI	REF	USB	DOT	Spread %
0	0	0	266.66	100	33.33	14.318	48	96	0.5 Down
0	0	1	133.33	100	33.33	14.318	48	96	0.5 Down
0	1	0	200.00	100	33.33	14.318	48	96	0.5 Down
0	1	1	166.66	100	33.33	14.318	48	96	0.5 Down
1	0	0	333.33	100	33.33	14.318	48	96	0.5 Down
1	0	1	100.00	100	33.33	14.318	48	96	0.5 Down
1	1	0	400.00	100	33.33	14.318	48	96	0.5 Down
1	1	1							RESERVED

27 Select	PIN 20/21	PIN 24/25
PIN13		
* 0	DOT_96 / DOT_96#	LCDCLK / LCDCLK#
1	SRC_0 / SRC_0#	27M / 27M_SS

ITP_EN (PIN14)	PIN53/54
0	SRC8#/SRC8
* 1	ITP/ITP#

Quanta Computer Inc.
PROJECT : Miata(NM3)

Size: Document Number
Clock Generator
Date: Friday, April 08, 2011
Sheet 3 of 32
Rev 1A

sualaptop365.edu.vn

Cedar View (CPU)



Disable Display Port

Disable Display Port

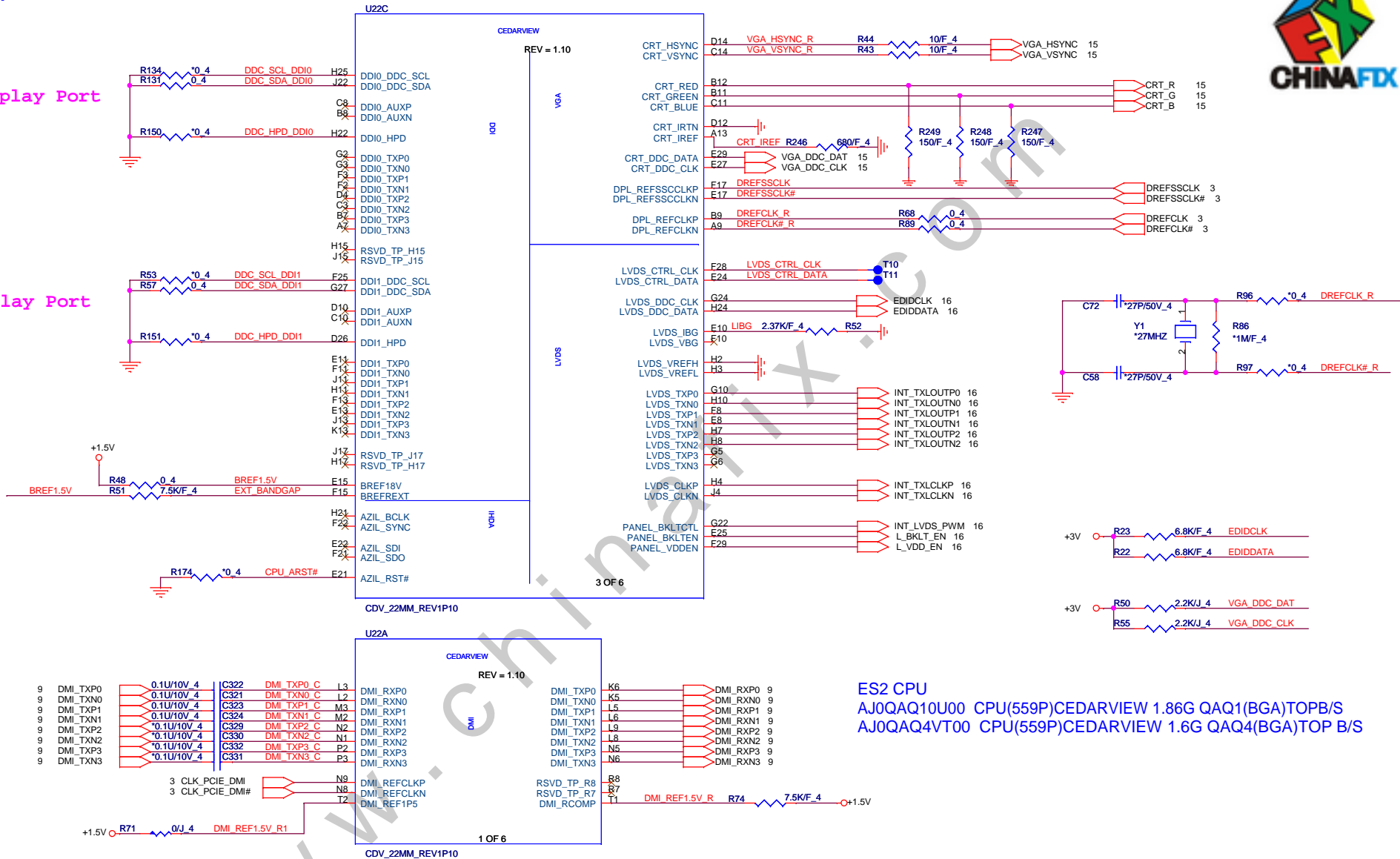

ES2 CPU
 AJ0QAQ10U00 CPU(559P)CEDARVIEW 1.86G QAQ1(BGA)TOPB/S
 AJ0QAQ4VT00 CPU(559P)CEDARVIEW 1.6G QAQ4(BGA)TOP B/S

Quanta Computer Inc.
 PROJECT : Miata(NM3)

Size	Document Number	Rev
	Cedarview DMI/Display(1/5)	1A
Date:	Thursday, April 07, 2011	Sheet 4 of 32

Cedar View (CPU)

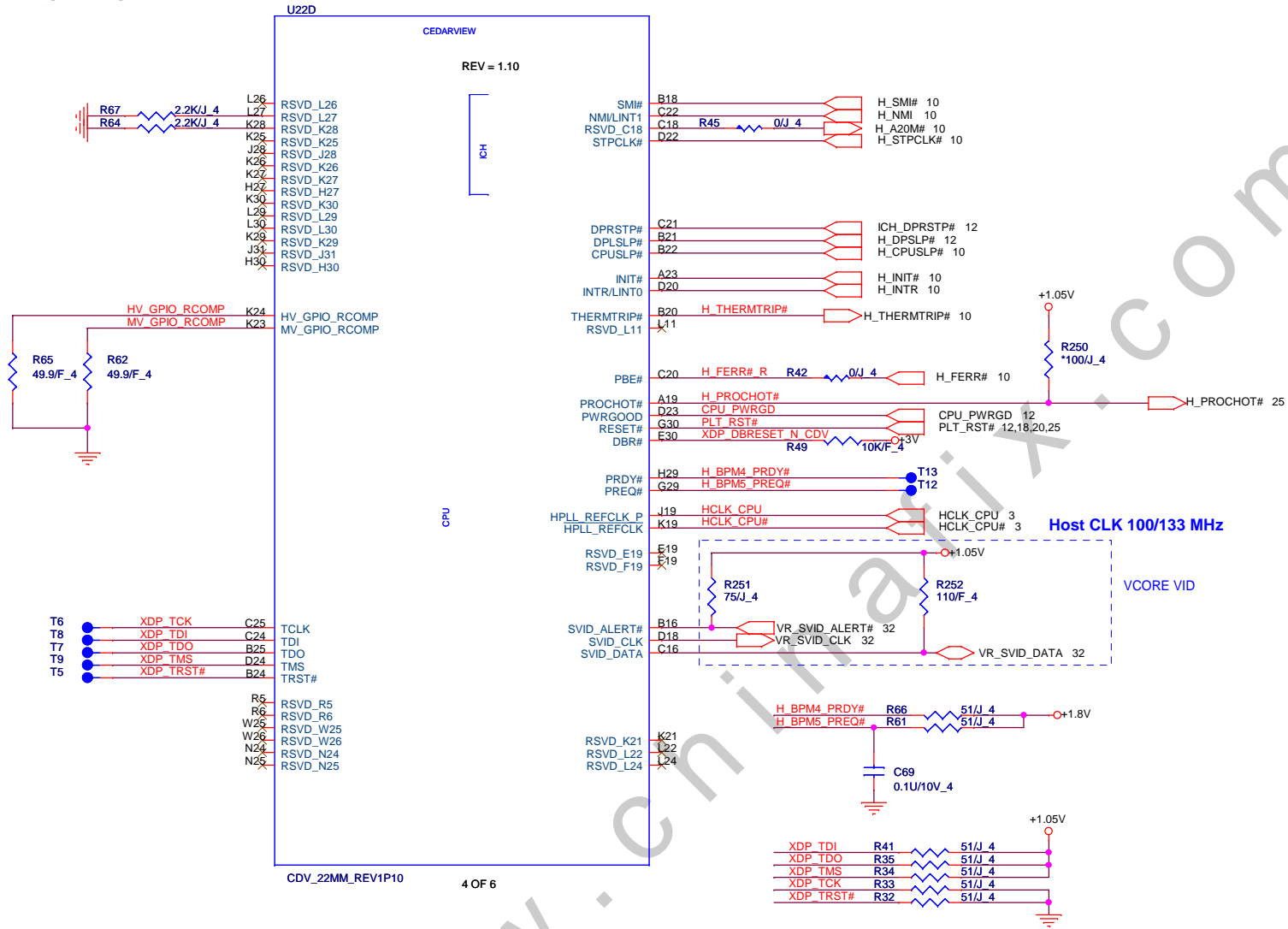

Quanta Computer Inc. PROJECT : Miata(NM3)		Rev
		1A
Size	Document Number	
Cedarview Miscellaneous(2/5)		
Date:	Thursday, April 07, 2011	Sheet 5 of 32

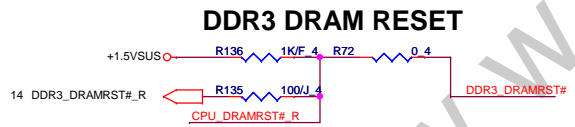
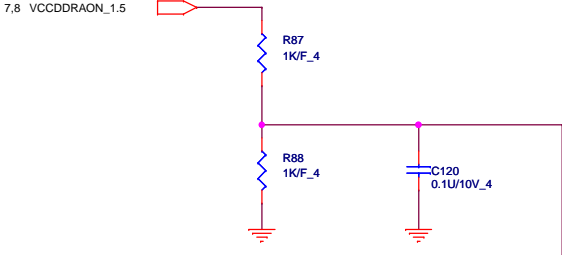
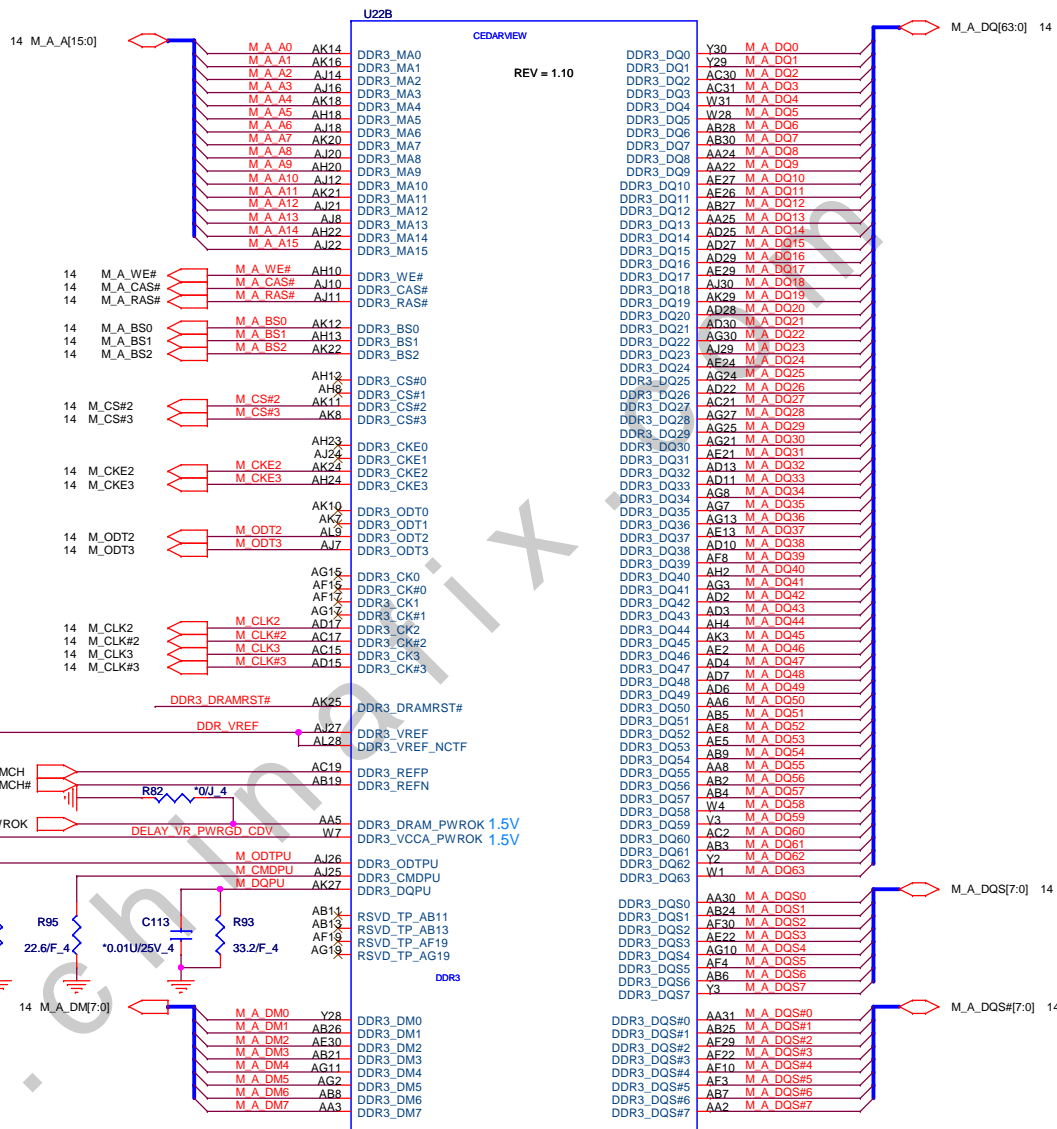

CDV_22MM_REV1P10 2 OF 6

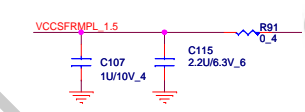
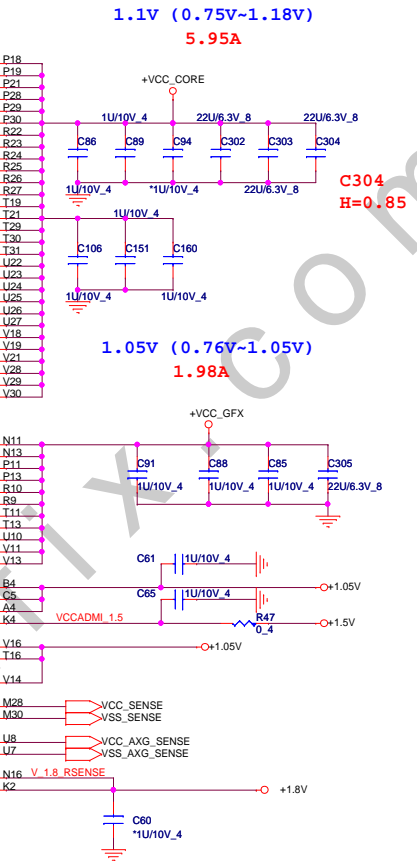
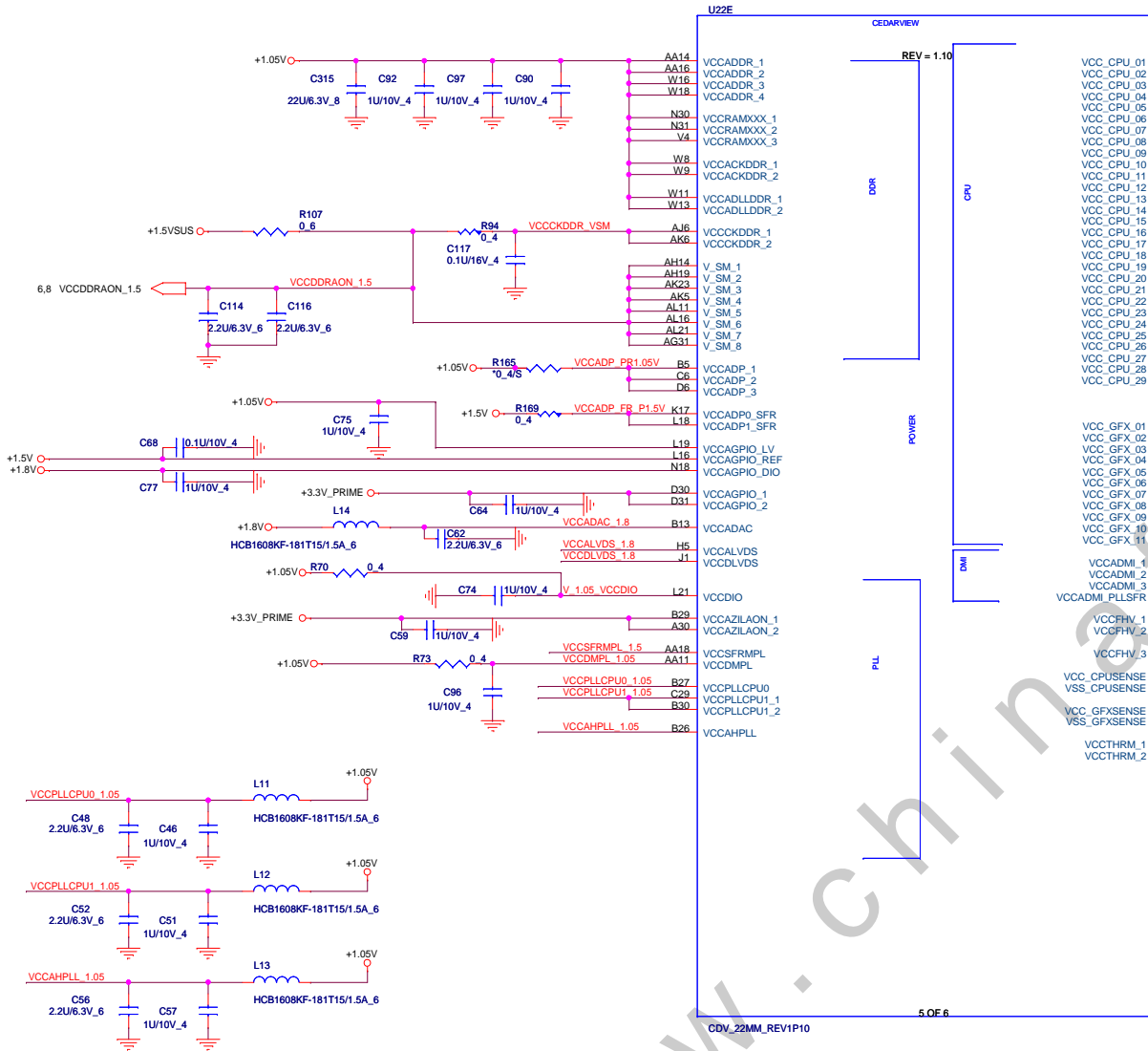

Cedar View LVDS Power

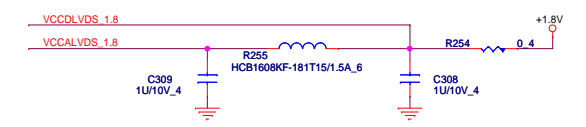

Cedar View (CPU)

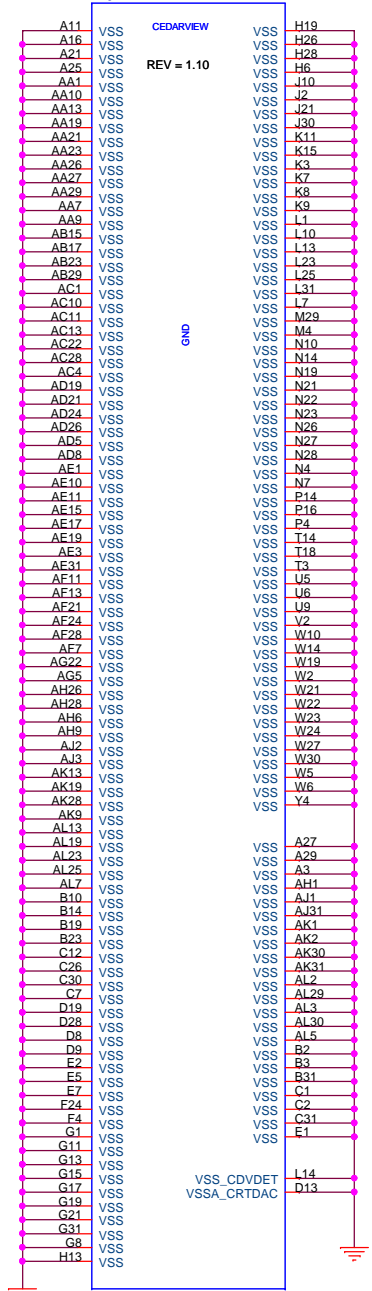

6 OF 6
CDV_22MM_REV1P10

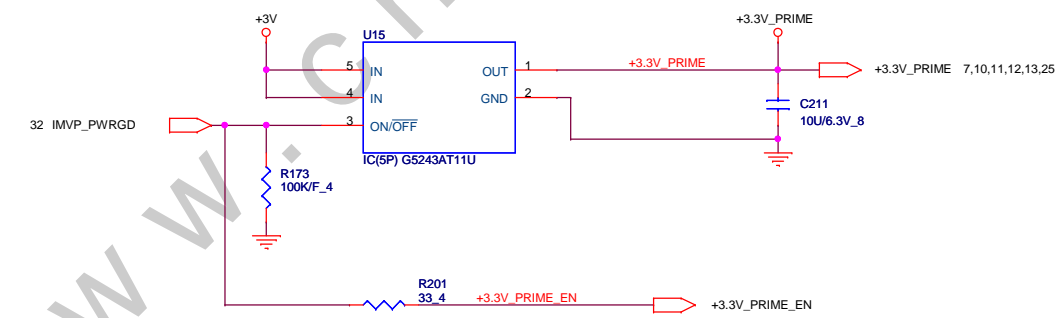
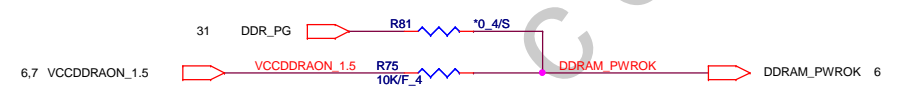
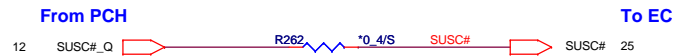

		Quanta Computer Inc. PROJECT : Miata(NM3)	
		Size: Document Number Cedarview Deep Standby(5/5)	Rev: 1A
Date: Thursday, April 07, 2011		Sheet 8 of 32	

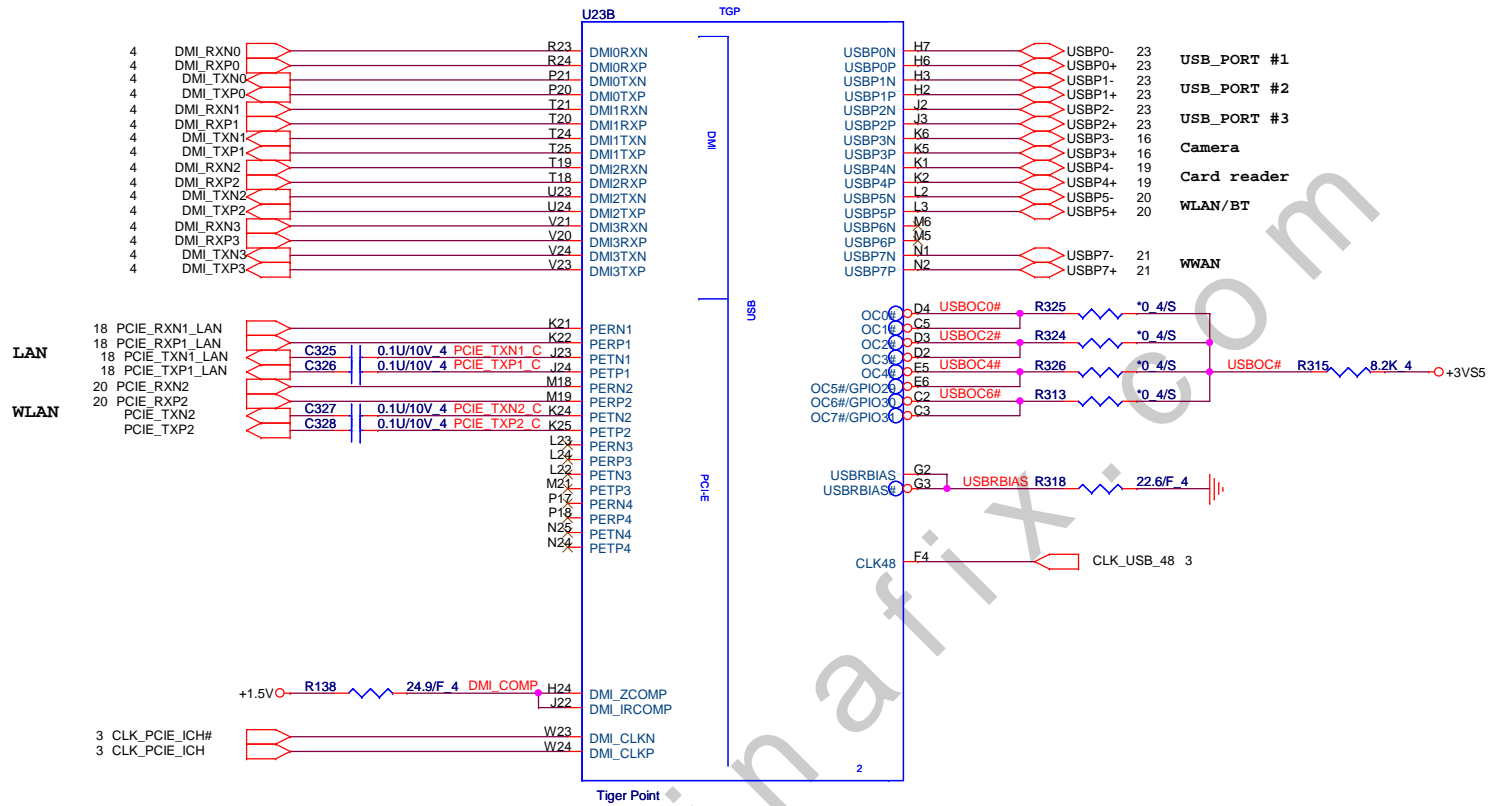

www.chinafix.com

 Quanta Computer Inc. PROJECT : Miata(NM3)		Rev 1A
Size	Document Number	
Tigerpoint DMI/PCIE(1/6)		
Date:	Thursday, April 07, 2011	Sheet 9 of 32

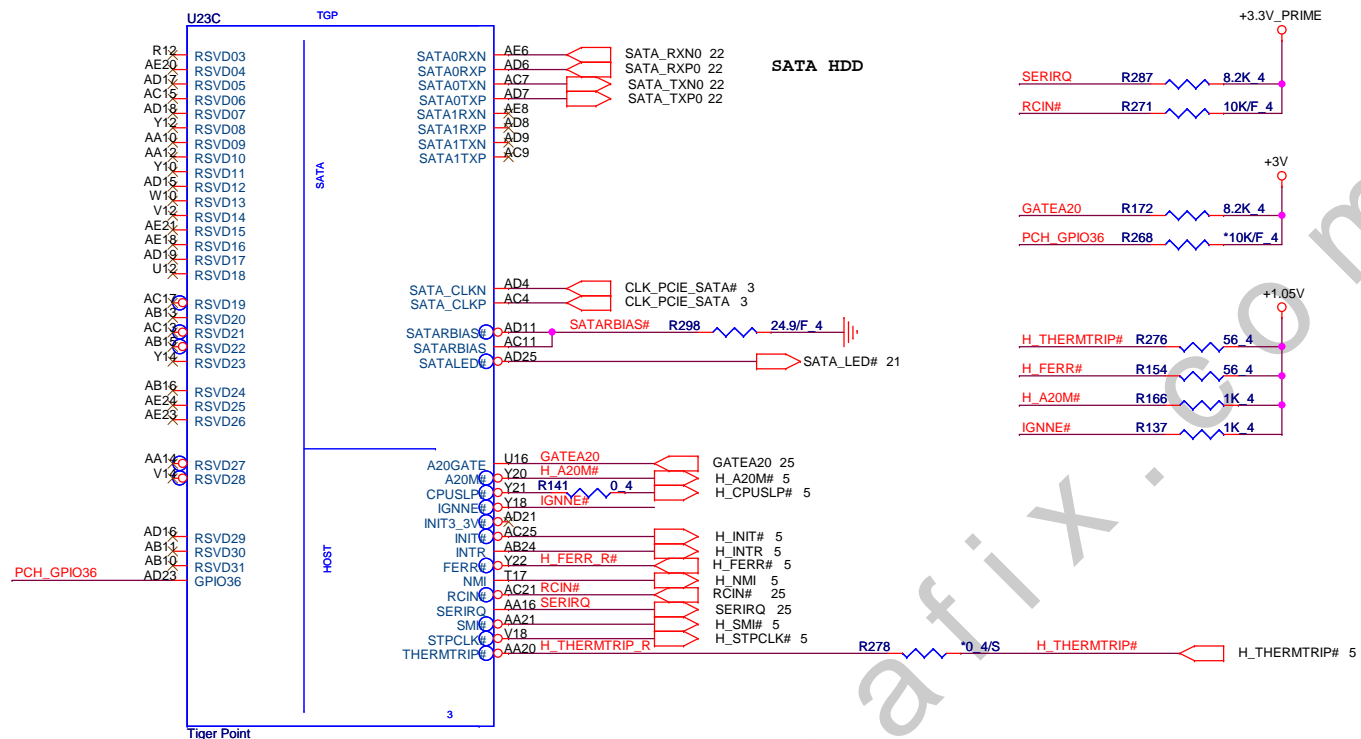

www.chinafix.com

		Quanta Computer Inc.
		PROJECT : Miata(NM3)
Size	Document Number	Rev
	Tigerpoint SATA/Host(2/6)	1A
Date:	Thursday, April 07, 2011	Sheet 10 of 32



ICH Boot BIOS select

PCH_GPIO17 (INT PU)	PCH_GPIO48 (INT PU)	Boot BIOS Location
0	1	SPI
1	0	PCI
1	1	LPC (Default)

A16 SWAP Override strap

PCH_A16WP (INT PU)	Low = A16 swap override enabled High = Default

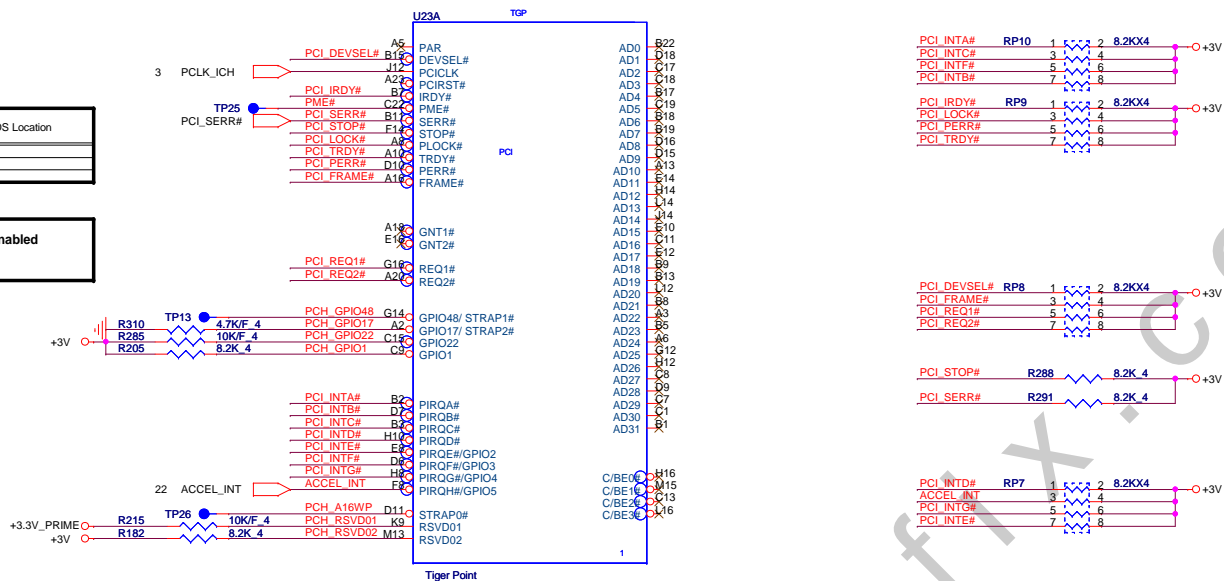

IRQ	Description
PIRQA	USB UHCI Controller #1, #4
PIRQB	AC97 Codec; option for SMBUS
PIRQC	USB UH Controller #3; SATA/IDE Native Mode
PIRQD	USB UHCI Controller #2
PIRQE	Internal LAN; Option for SCI, TCO, HPET#0,1,2
PIRQF	Option for SCI, TCO, HPET#0,1,2
PIRQG	Option for SCI, TCO, HPET#0,1,2
PIRQH	USB EHCI Controller; Option for SCI, TCO, HPET#0,1,2
PCI_GNT#2	Internal PU Should not be PD

Quanta Computer Inc.
PROJECT : Miata (NM3)

Size	Document Number	Rev
	Tigerpoint PCI(3/6)	1A
Date:	Thursday, April 07, 2011	Sheet 11 of 32

4.5,8,10,20,25,28,32 +3V

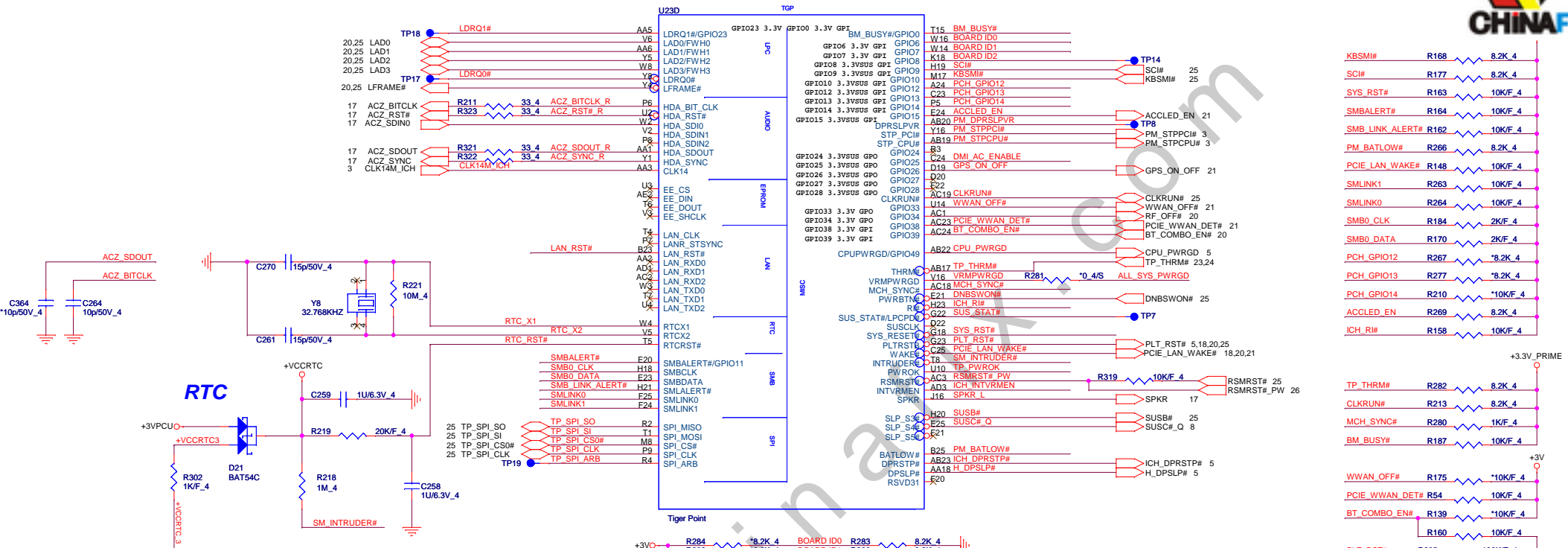

Firmware Reversion:

	Beats	non-Beats
BOARD_ID0 (GPIO6)	0 (Low)	1 (High)

	INTVRMEN
Enable (default)	1
Disable	0

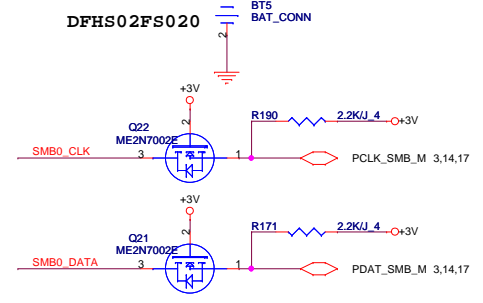

GPIO25 This signal has a weak internal pull-up. If the signal is sampled high, the DMI interface is strapped to operate in DC coupled mode (No coupling capacitors are required on DMI differential pairs). If the signal is sampled low, the DMI interface is strapped to operate in AC coupled mode (Coupling capacitors are required on DMI differential pairs). NOTE: Board designer must ensure that DMI implementation matches the strap selection.

DMI_AC_ENABLE R132 1K/F 4

ACZ_SDOUT (INT PD)	ACZ_SYNC (INT PD)	Description
0	0	* 4 x 1s
1	0	Reserved
0	1	Reserved
1	1	1 x 4s(1 port/4 lanes)

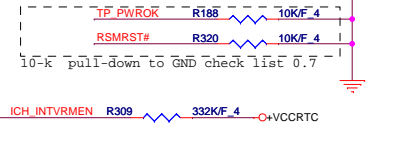
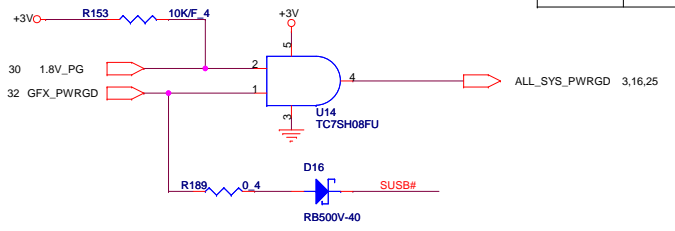

Quanta Computer Inc.
PROJECT : Miata (NM3)

Size Document Number Tigerpoint GPIO(4/6) Rev 1A
Date: Thursday, April 07, 2011 Sheet 12 of 32

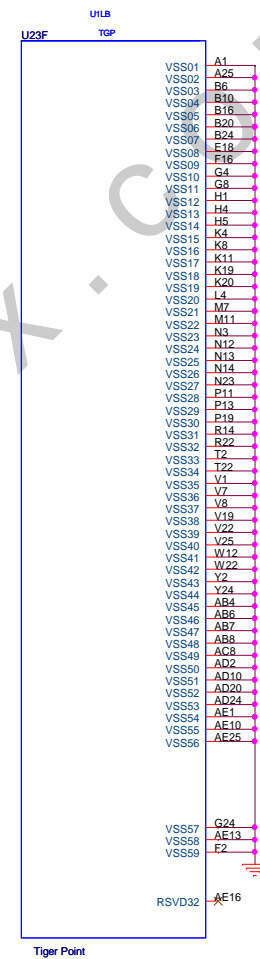
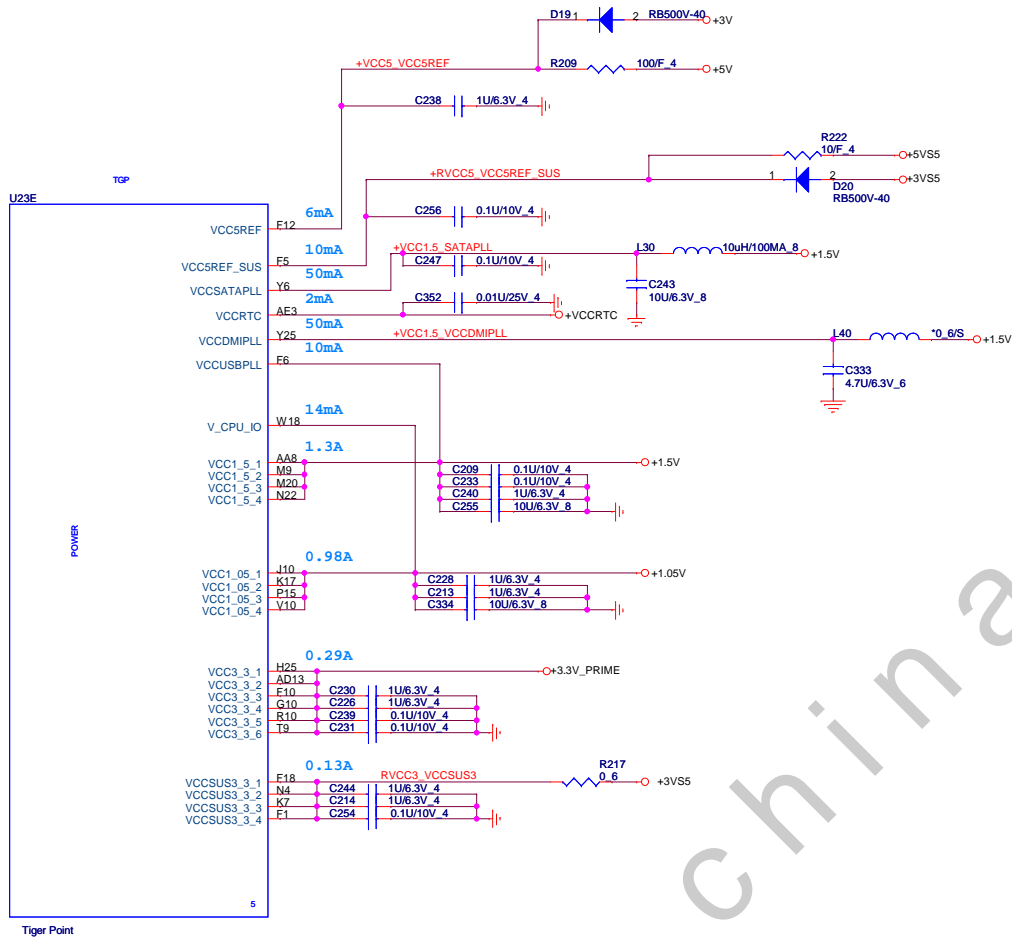

Quanta Computer Inc.
PROJECT : Miata (NM3)

Size	Document Number	Rev
	Tigerpoint Power(5/6)	1A
Date:	Thursday, April 07, 2011	Sheet 13 of 32

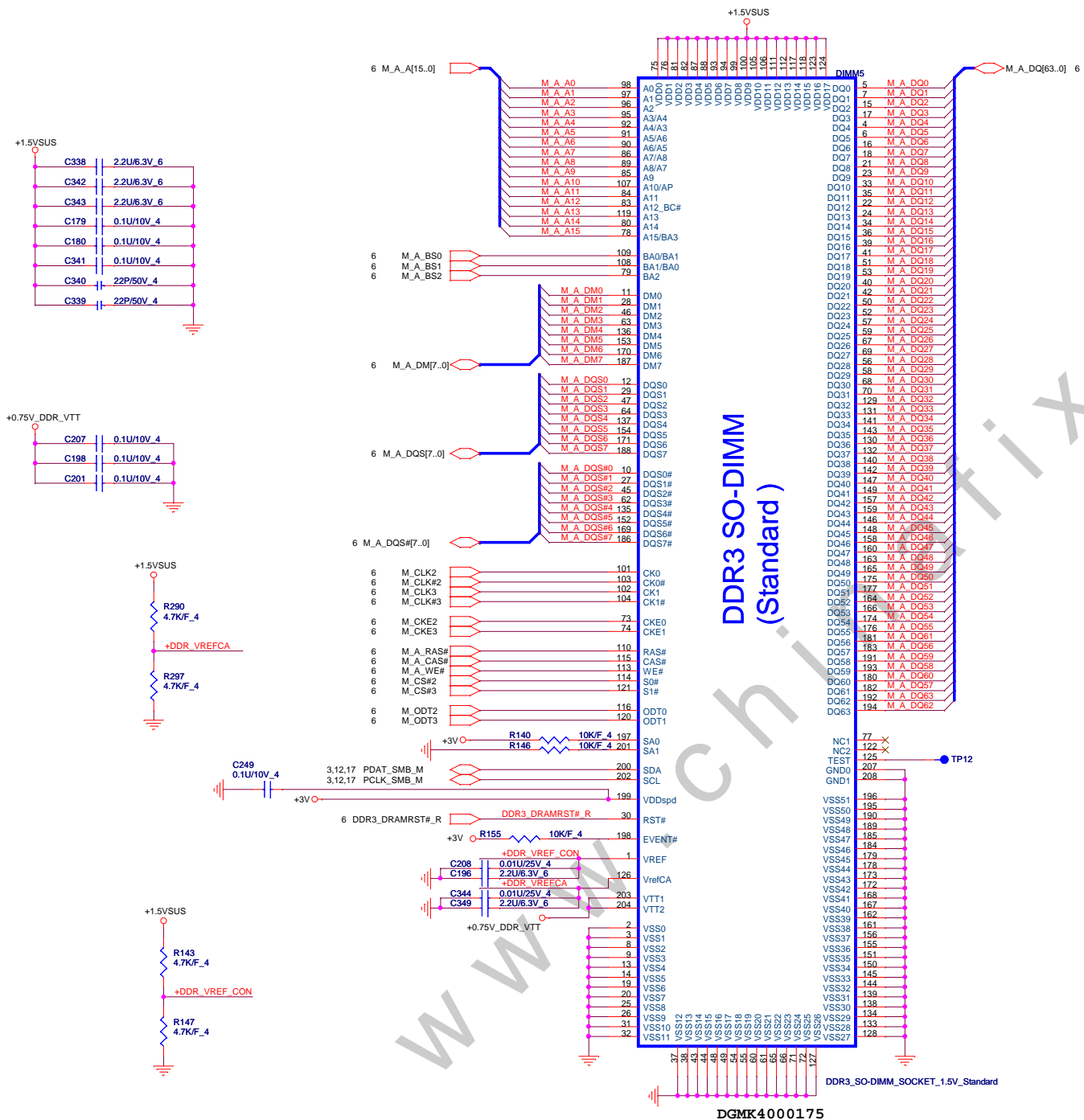



DDR3 SO-DIMM
 (Standard)

		Quanta Computer Inc. PROJECT : Miata (NM3)	
		Date: Thursday, April 07, 2011	Sheet 14 of 32
Size:	Document Number:	DDRIII SODIMM	Rev: 1A

4,5,8,10,20,25,28,32 +3V
5,7,10,22,28,29,32 +1.05V

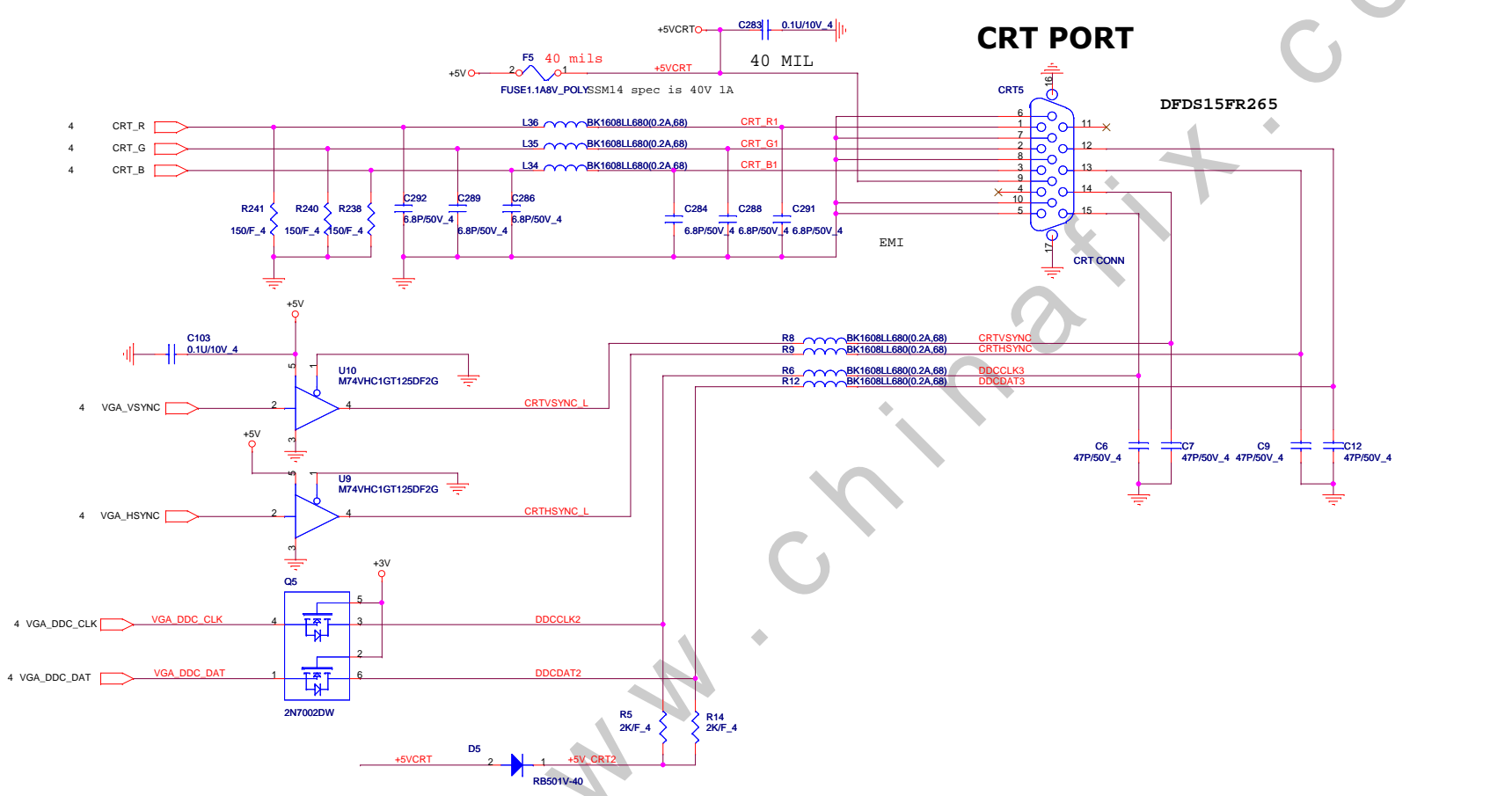
CRT PORT



 Quanta Computer Inc. PROJECT : Miata (NM3)		Rev. 1A
CRT Connector		
Date:	Friday, April 08, 2011	Sheet 15 of 32

LED Panel(LDS)

Backlight Control(LDS)

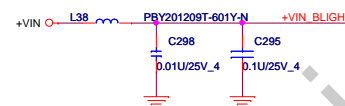
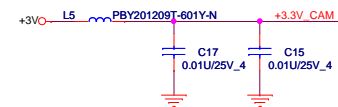
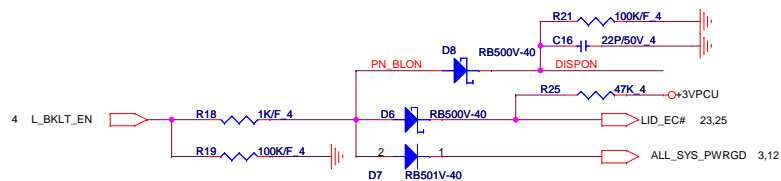

Close to LCD Connector

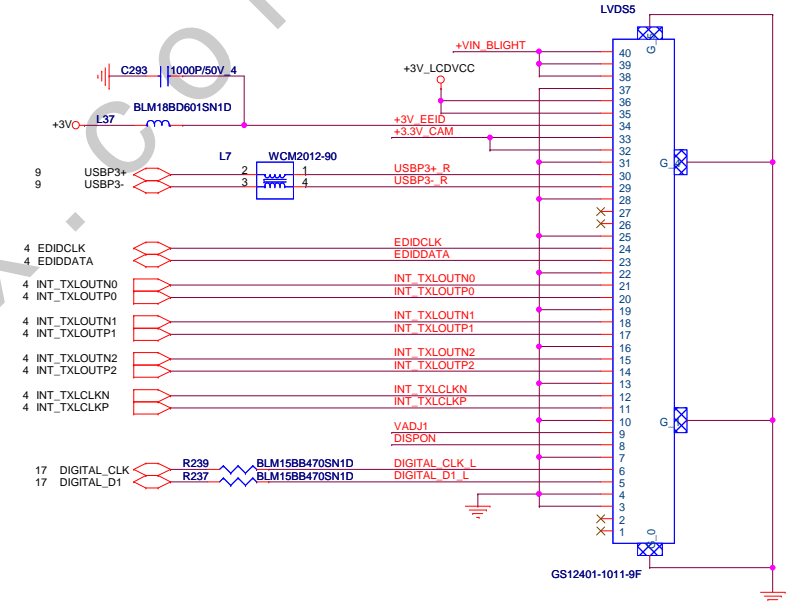
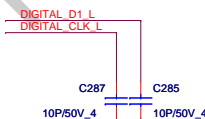
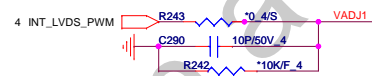

DFHS40FS030
DFHS40FS036
DFHS40FS047

LCD POWER SWITCH

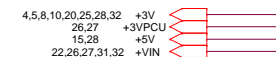
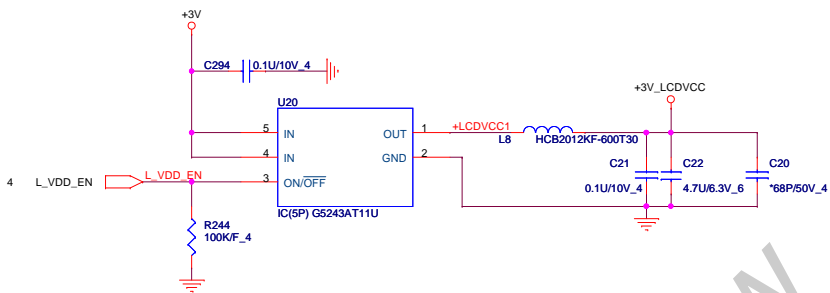

		Quanta Computer Inc. PROJECT : Miata (NM3)	
		Size Document Number LCD Panel/Camera/TP Screen	Rev 1A
Date: Thursday, April 07, 2011		Sheet 16 of 32	

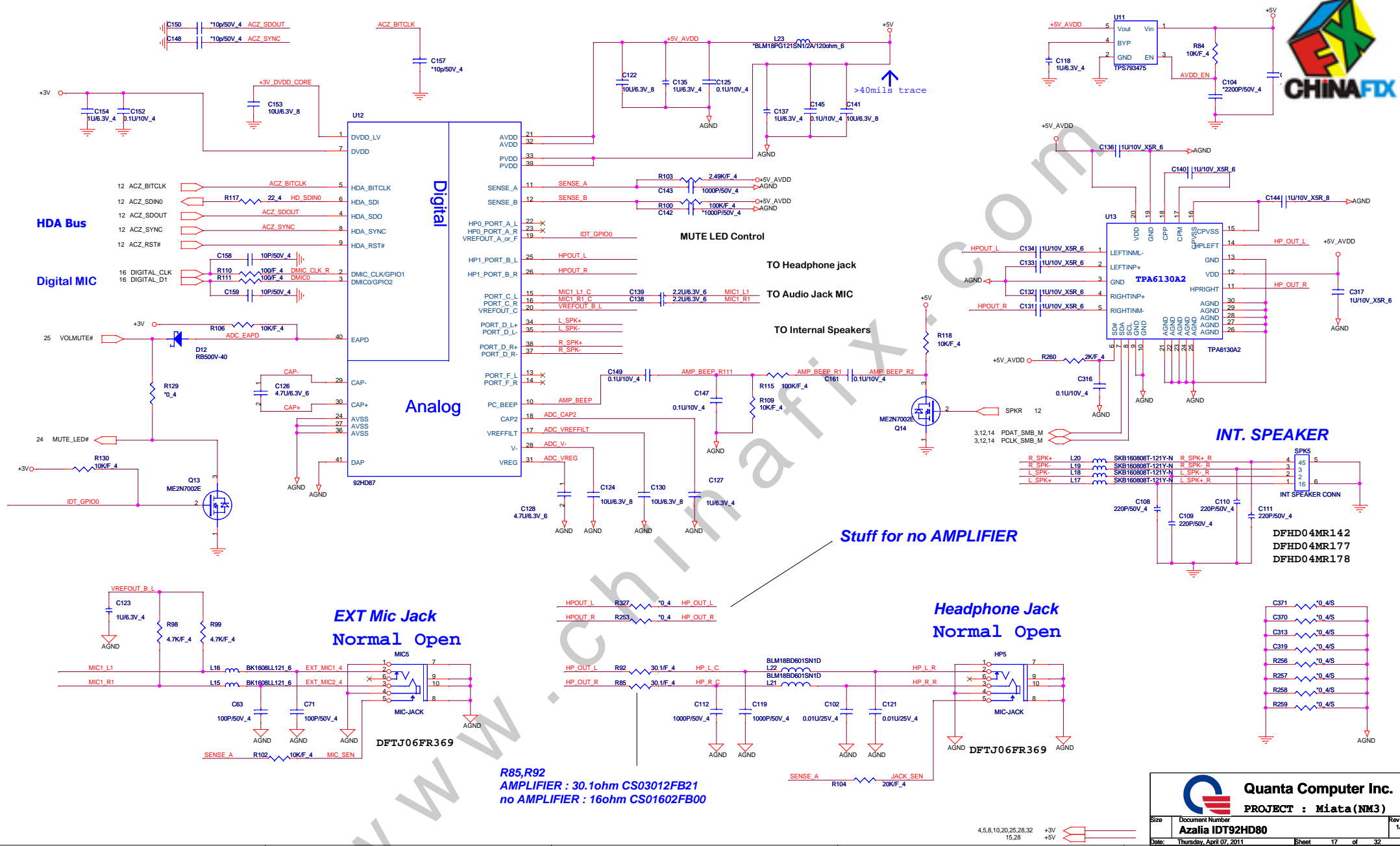

R85,R92
AMPLIFIER : 30.1ohm CS03012FB21
no AMPLIFIER : 16ohm CS01602FB00

Quanta Computer Inc.
PROJECT : Miata(NM3)

Size	Document Number	Rev
4.5,8,10,20,25,28,32	Azalia IDT92HD80	1A
15,28		

Date: Thursday, April 07, 2011 Sheet 17 of 32



For EMI 0 ~ 22 ohm

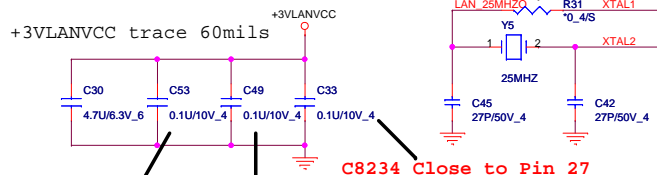

C8233 Close to Pin 19

C8234 Close to Pin 27

C8232 Close to Pin 1

+1.14V_LAN

+1.14V trace 60mils

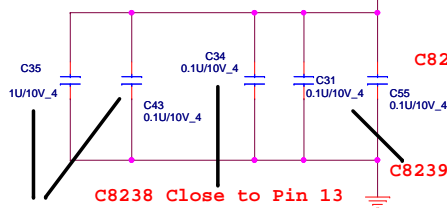

C8241 Close to Pin 21

C8238 Close to Pin 13

C8247 Close to Pin 31

WWW.Chinafox.com

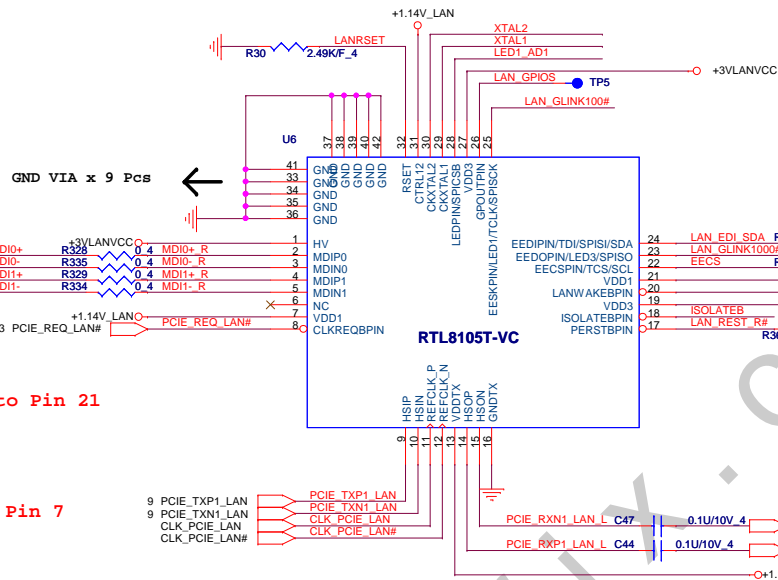

GND VIA x 9 Pcs

EEDI must 10K pull down for autoload
EECS must 10K pull down for test mode

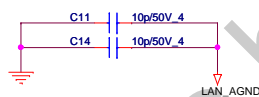
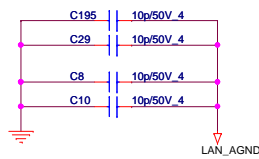

Transformer for 10/100

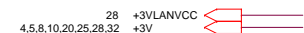
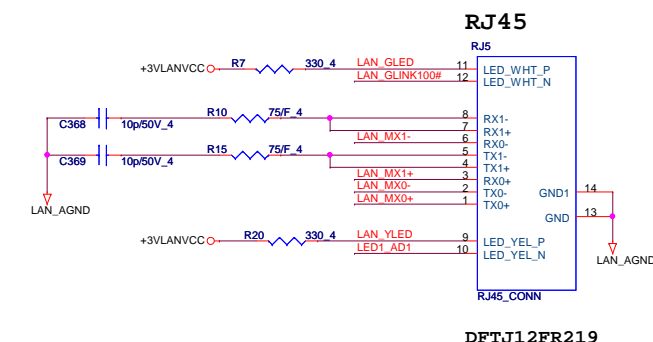
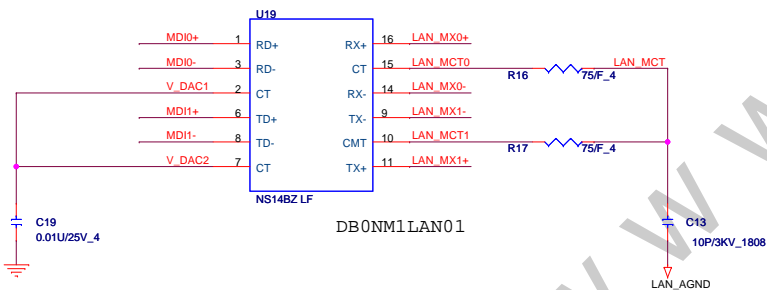

Quanta Computer Inc.
PROJECT : Miata (NM3)

Size	Document Number	Rev
	RTL8105T-VC/RJ45	1A
Date:	Thursday, April 07, 2011	Sheet 18 of 32

Share Pin

	XD_CD#			
SP1	XD_RDY#	SD_WP	MS_CLK	
SP2	XD_RE#		MS_INS#	
SP3	XD_CE#	SD_D1		
SP4	XD_CLE	SD_D0	MS_D7	
SP5	XD_ALE	SD_D7	MS_D3	
SP6	XD_WE#	SD_CD#		
SP7	XD_WP	SD_D6	MS_D6	
SP8	XD_D0	SD_CLK	MS_D2	
SP9	XD_D1	SD_D5	MS_D0	
SP10	XD_D2	SD_CMD		
SP11	XD_D3	SD_D4	MS_D4	
SP12	XD_D4	SD_D3	MS_D1	
SP13	XD_D5	SD_D2	MS_D5	
SP14	XD_D6		MS_BS	
	XD_D7			

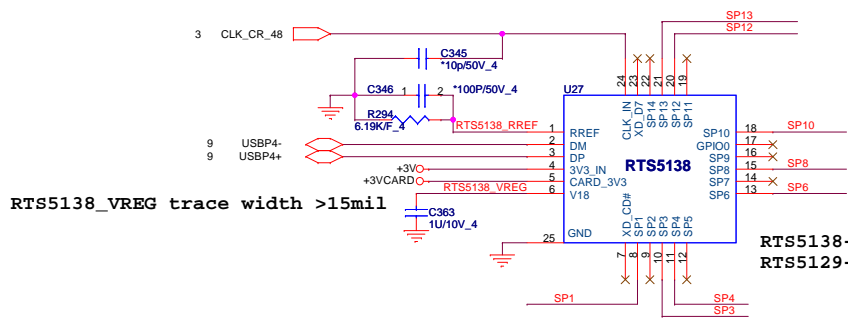

RTS5138-GRT --> AL005138000
 RTS5129-GRT --> AL005129000

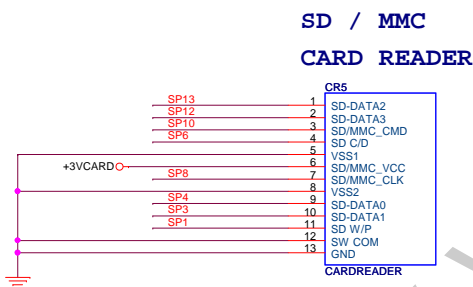
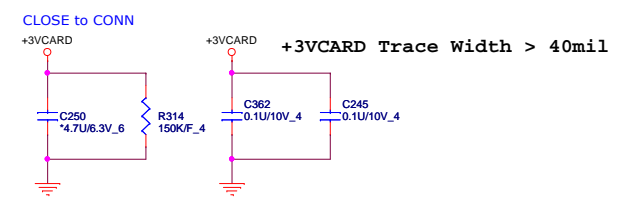
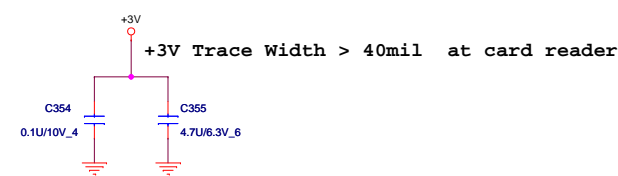

DFHS11FR079
 DFHS11FR081

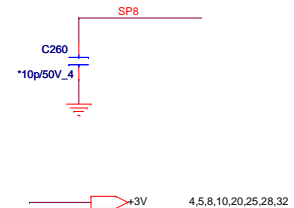

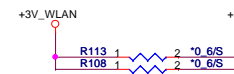
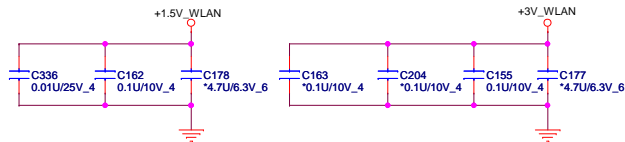
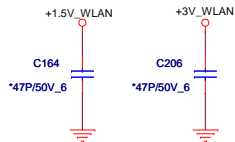

Mini PCI-E Card 1 Half Mini PCI-E WLAN

The value of the capacitor is suggest by Siemens HQ expert.
For against 900MHz RF interference. The value of capacitor is 27pF.
For against 1800MHz RF interference. The value of capacitor is 10pF.
1nF/10nF value capacitor use for against ESD purpose.

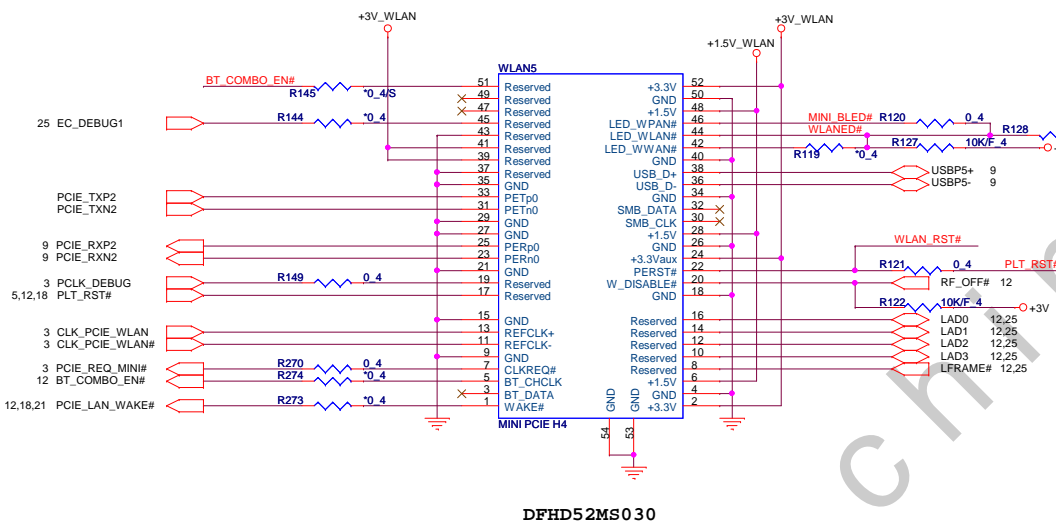

IF add WLAN_RST# schematic
R278 must change to 10K

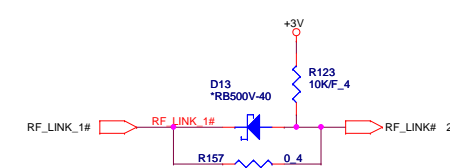

DFHD52MS030

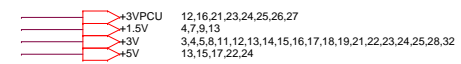

		Quanta Computer Inc. PROJECT : Miata(NM3)	
		Size Document Number Mini PCI-E(WLAN)	Rev 1A
Date: Thursday, April 07, 2011		Sheet 20 of 32	

Full mini PCIE for WWAN Mini PCI-E Card 2

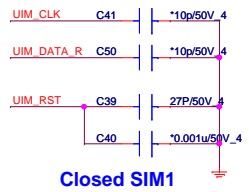
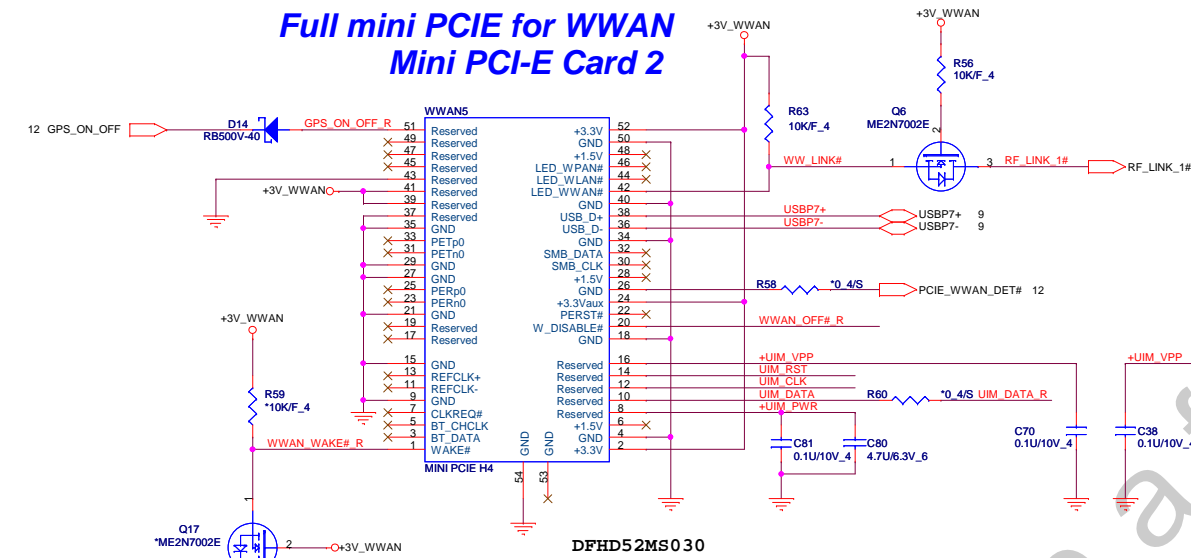

SIM CARD SIGNALS ROUTE PARALLEL

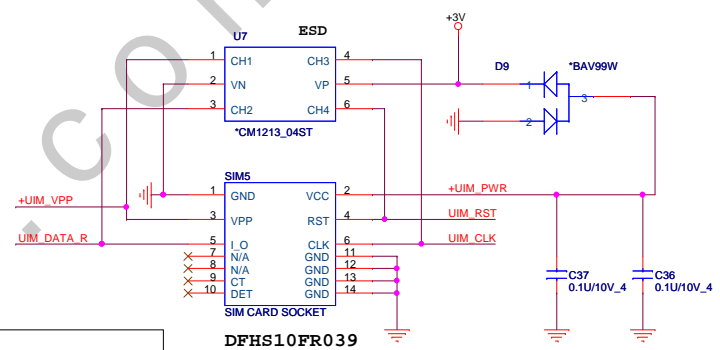

DFHS10FR039 SIM CARD

RF solution

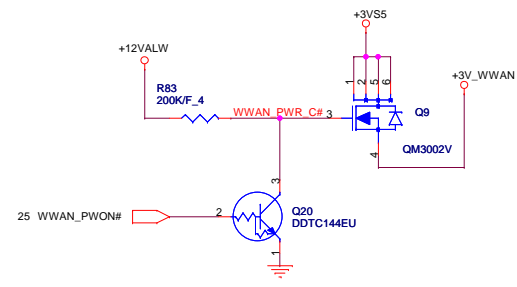
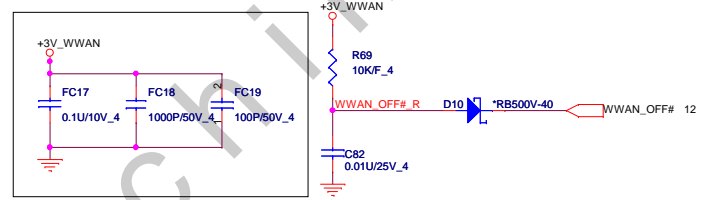

Charging & Discharging/LED

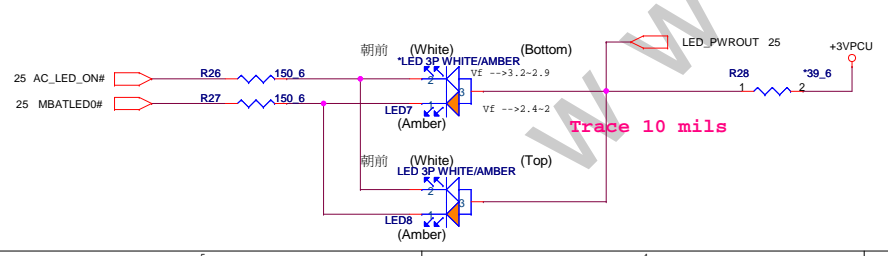

SATA/G sensor LED

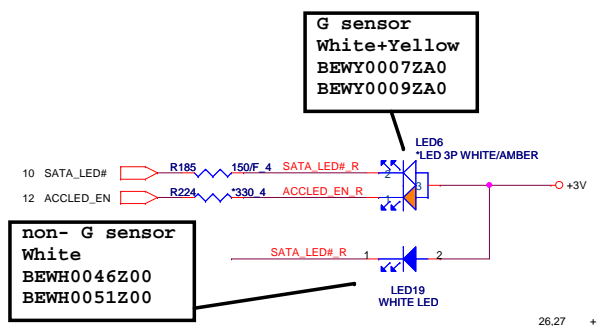

Touchpad LED

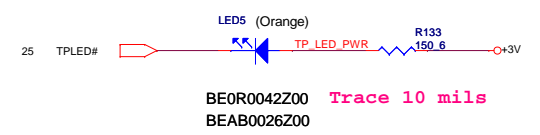

Quanta Computer Inc.
 PROJECT : Miata(NM3)

Size	Document Number	Rev
	Mini PCIE(WWAN)/LED	1A
Date:	Thursday, April 07, 2011	Sheet 21 of 32

2.5" SATA HDD OR SSD(TOSHIBA)

DFHD20MR023

DC Current rating: 0.5 A

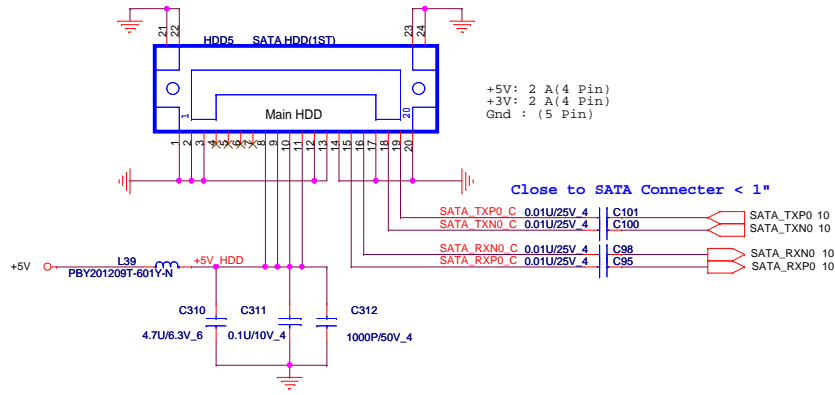

Accelerometer Sensor

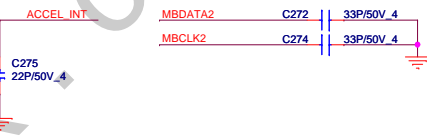
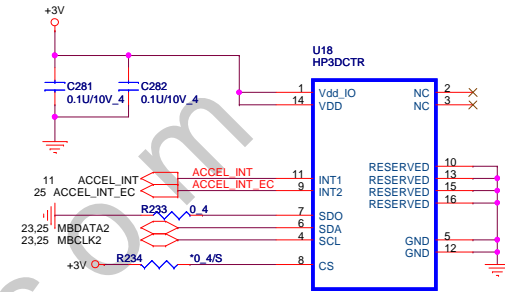

RF solution

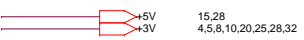
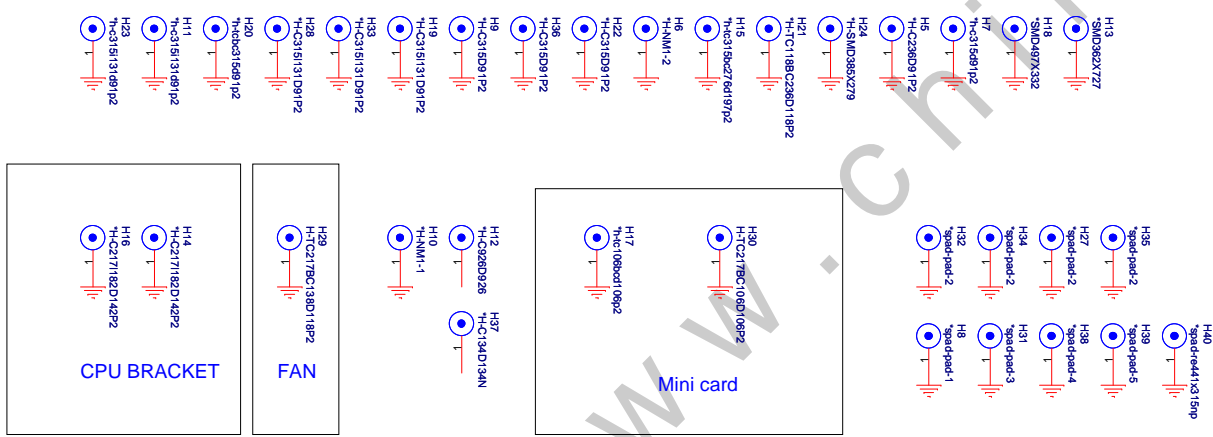
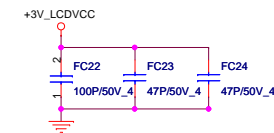
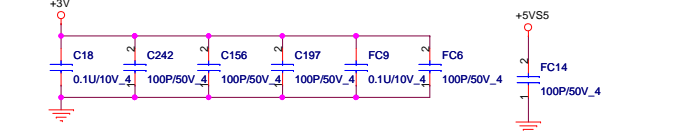
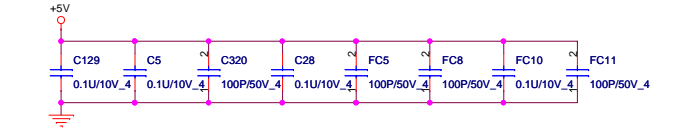
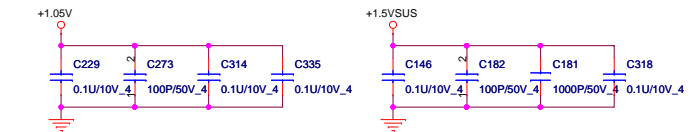
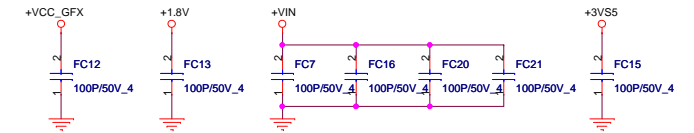

Quanta Computer Inc.
PROJECT : Miata (NM3)

Size	Document Number	Rev
	HDD/Hole/G Senser/RF	1A
Date:	Thursday, April 07, 2011	Sheet 22 of 32

1x Left side USB port supports Keyed USB.

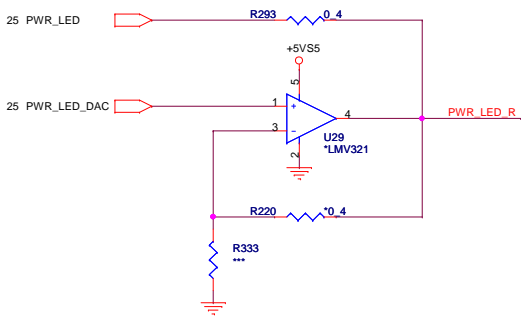
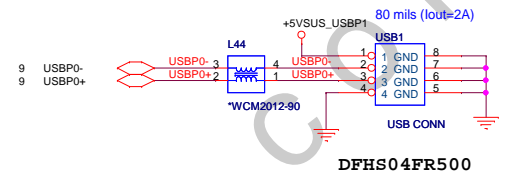
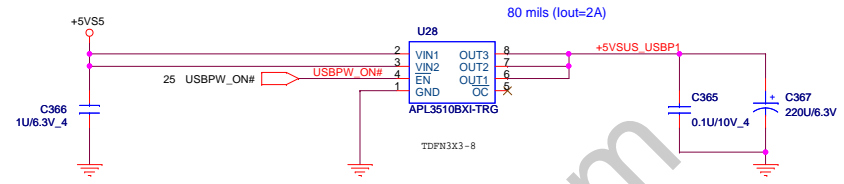
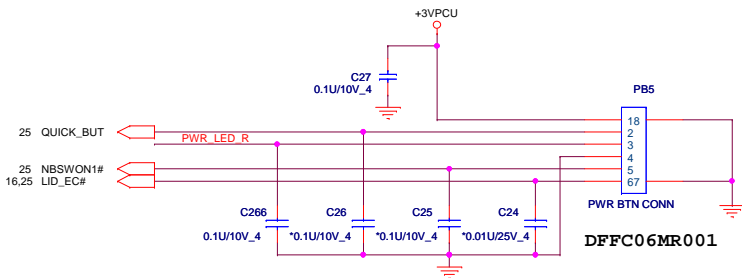

For Right 2xUSB Ports PWR

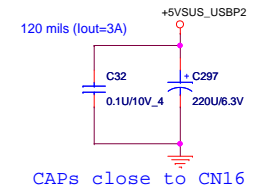
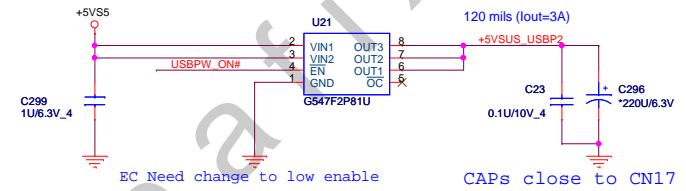

CPU Thermal

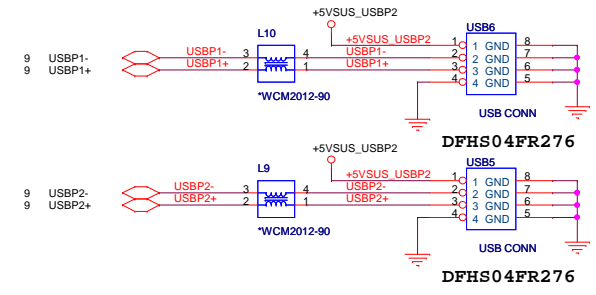
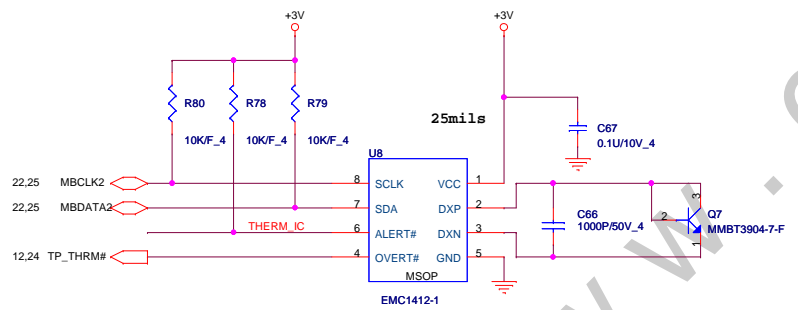

+3VPCU 26,27
+3V 4,5,8,10,20,25,28,32

Quanta Computer Inc.
PROJECT : Miata (NM3)

Size	Document Number	Rev
	Power Board/USB	1A
Date:	Thursday, April 07, 2011	Sheet 23 of 32

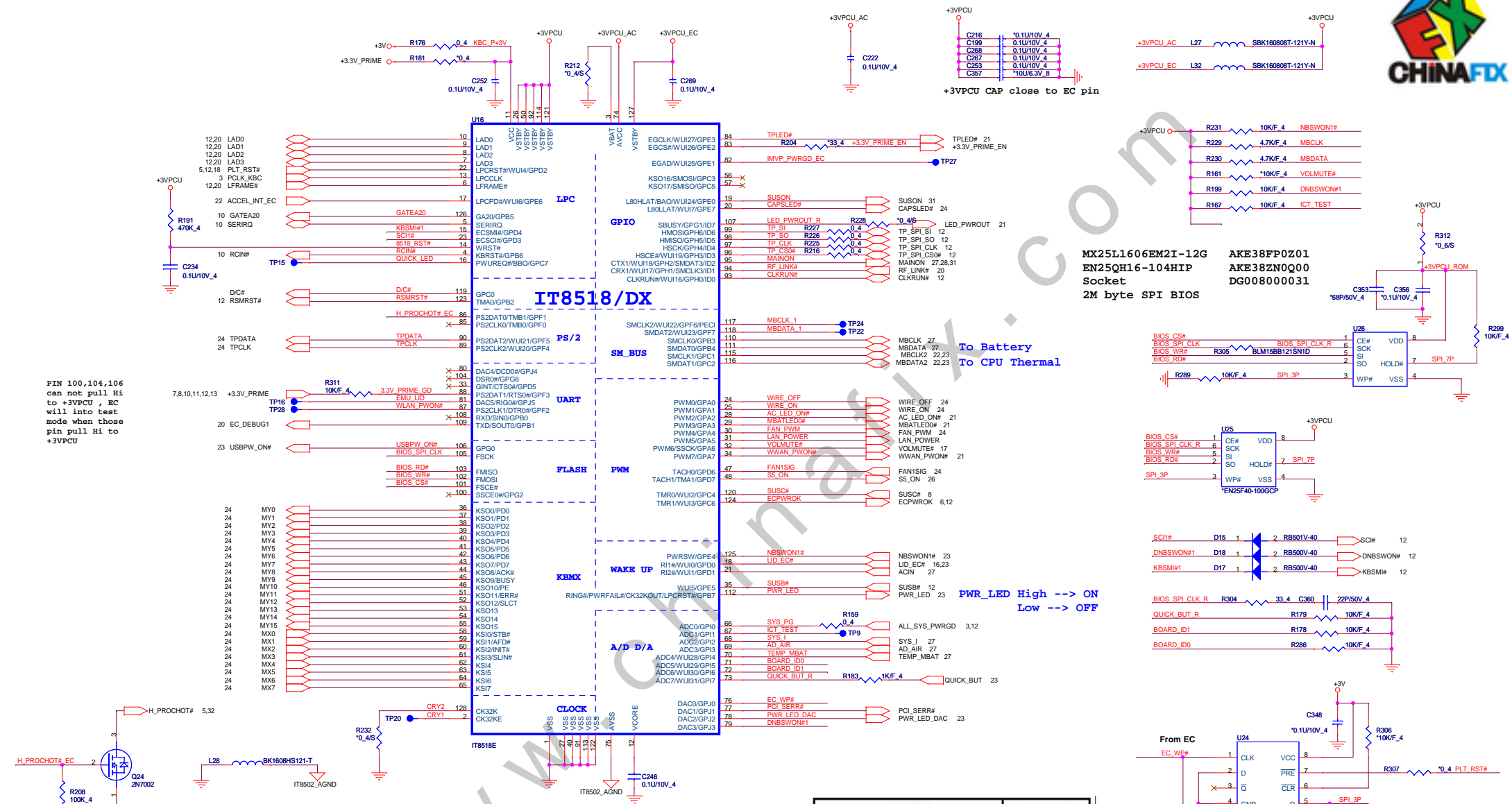

PIN 100,104,106 can not pull Hi to +3VPCU, EC will into test mode when those pin pull Hi to +3VPCU

MX25L1606EM2I-12G
EN25QH16-104HIP
Socket
2M byte SPI BIOS

AKE38FP0Z01
AKE38ZNQ000
DG008000031

To Battery
To CPU Thermal

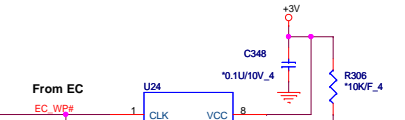
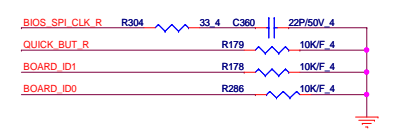
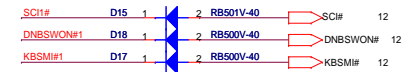
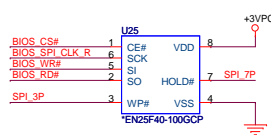
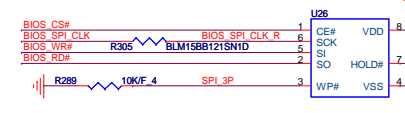

Firmware Reversion:

	Old Fan	New Fan
	Old LED	New LED
BOARD_ID0 (GPI5)	1 (High)	0 (Low)

	NM1	NM3
BOARD_ID1 (GPI6)	1 (High)	0 (Low)

		INPUTS		OUTPUTS	
PRE	CLR	CLK	D	Q	Q _b
L	H	X	X	H	L
H	L	X	X	L	H
L	L	X	X	H ₍₀₎	H ₍₁₎
H	H	↑	H	H	L
H	H	↑	L	L	H
H	H	L	X	Q _b	Q _b

FLASH

LOCK

Quanta Computer Inc.
PROJECT : Miata (NM3)

Size: Document Number: **KBC ITE8518/ROM** Rev: 1A

Date: Thursday, April 07, 2011 Sheet: 25 of 32

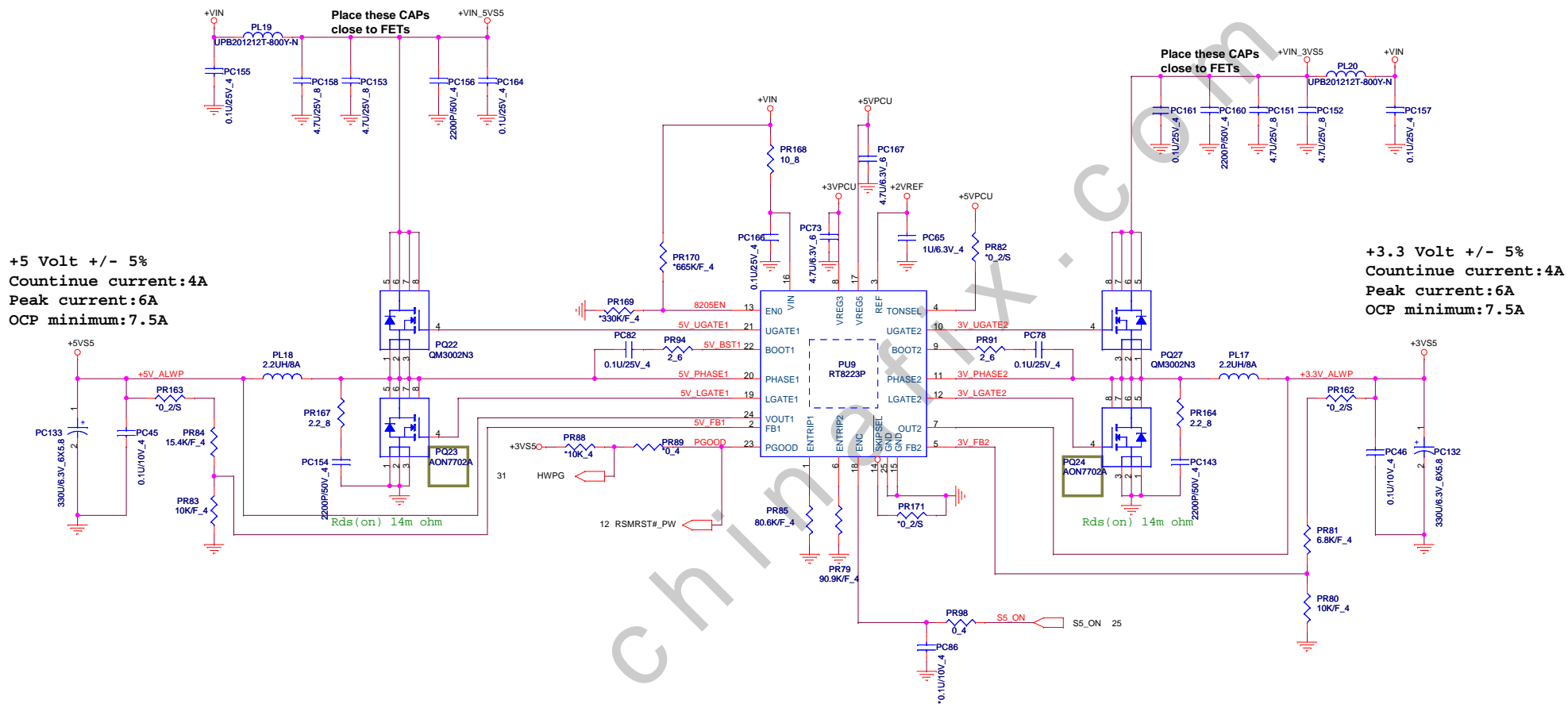

+5 Volt +/- 5%
Countinue current:4A
Peak current:6A
OCP minimum:7.5A

+3.3 Volt +/- 5%
Countinue current:4A
Peak current:6A
OCP minimum:7.5A

WWW.CHINAFOX.COM

		Quanta Computer Inc. PROJECT : Miata(NM3)	
		Size Document Number 3VPCU/5VPCU(RT8223)	Rev 1A
Date: Friday, April 08, 2011		Sheet 26	of 32



Main DFHD04MR146
Sec DFHD04MR246

Do Not add test pad on BATDIS_G signal

Place this ZVS close to Diode away +VIN

Place this ZVS close to Far-Far away +VIN

DFHD05MR130

Place this cap close to EC

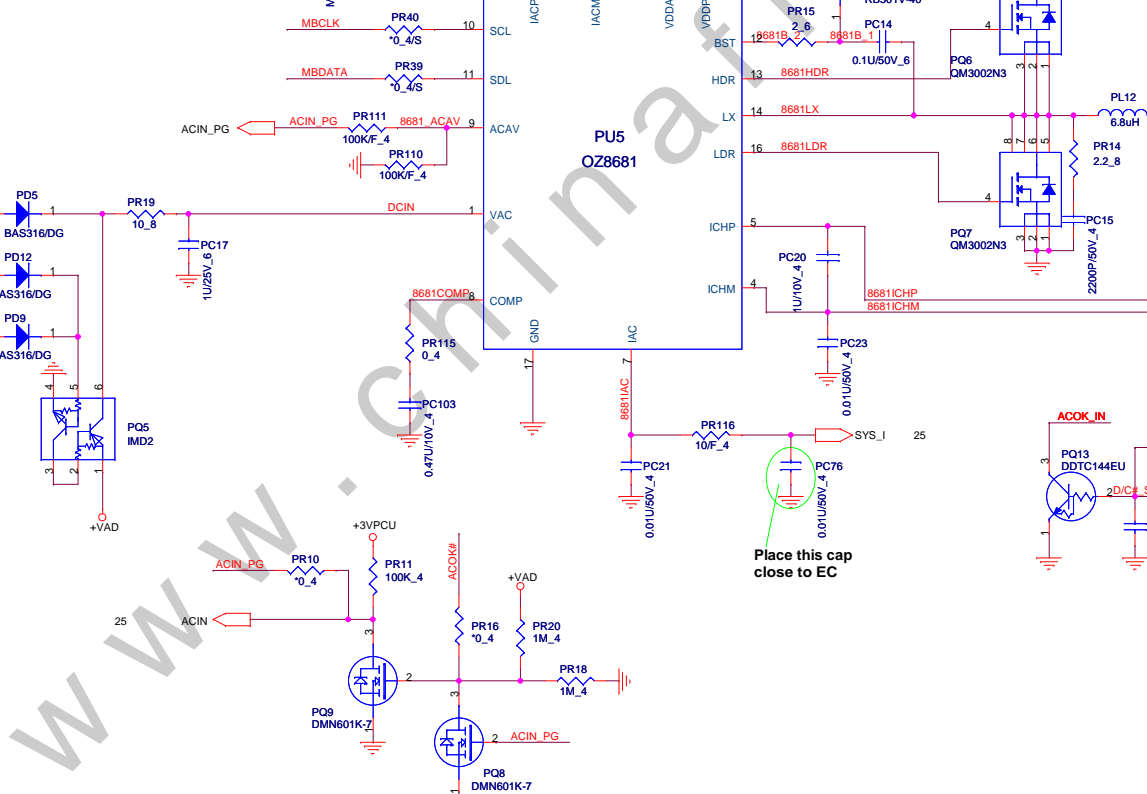
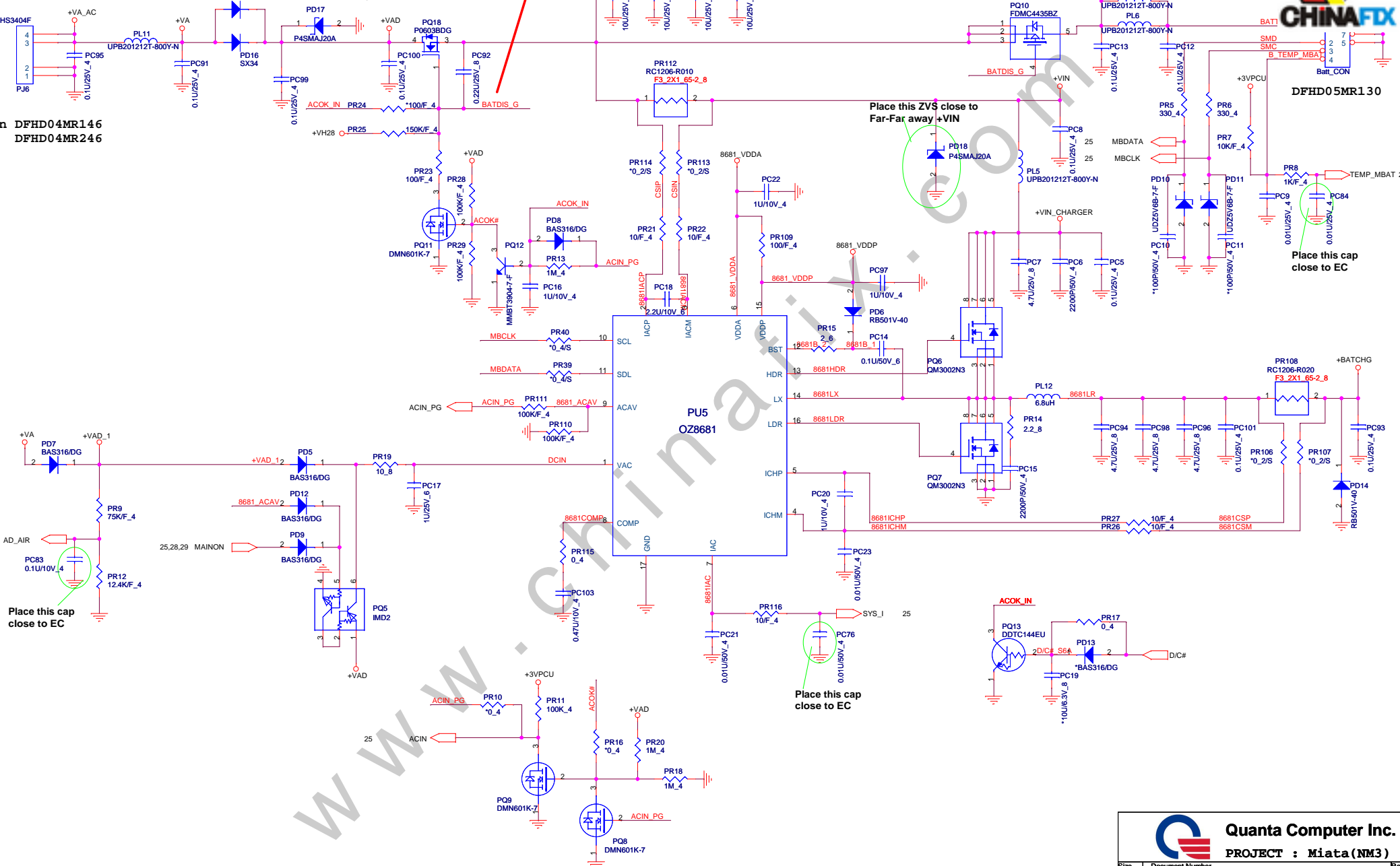

Quanta Computer Inc.
PROJECT : Miata (NM3)

Size	Document Number	Rev
	CHARGER (OZ8681)	1A
Date:	Friday, April 08, 2011	Sheet 27 of 32

- +VAD 27
- +5V 13,15,17,22,24
- +VIN 16,22,26,27,31,32
- +1.5V 4,7,9,13
- +3VS5 9,12,13,21,22,26,29,30
- +5VS5 13,22,23,26,29,30,31,32
- +VH28 27
- +VAD_1 27
- +1.5VSUS 6,7,14,22,31
- +3VLAVCC 18

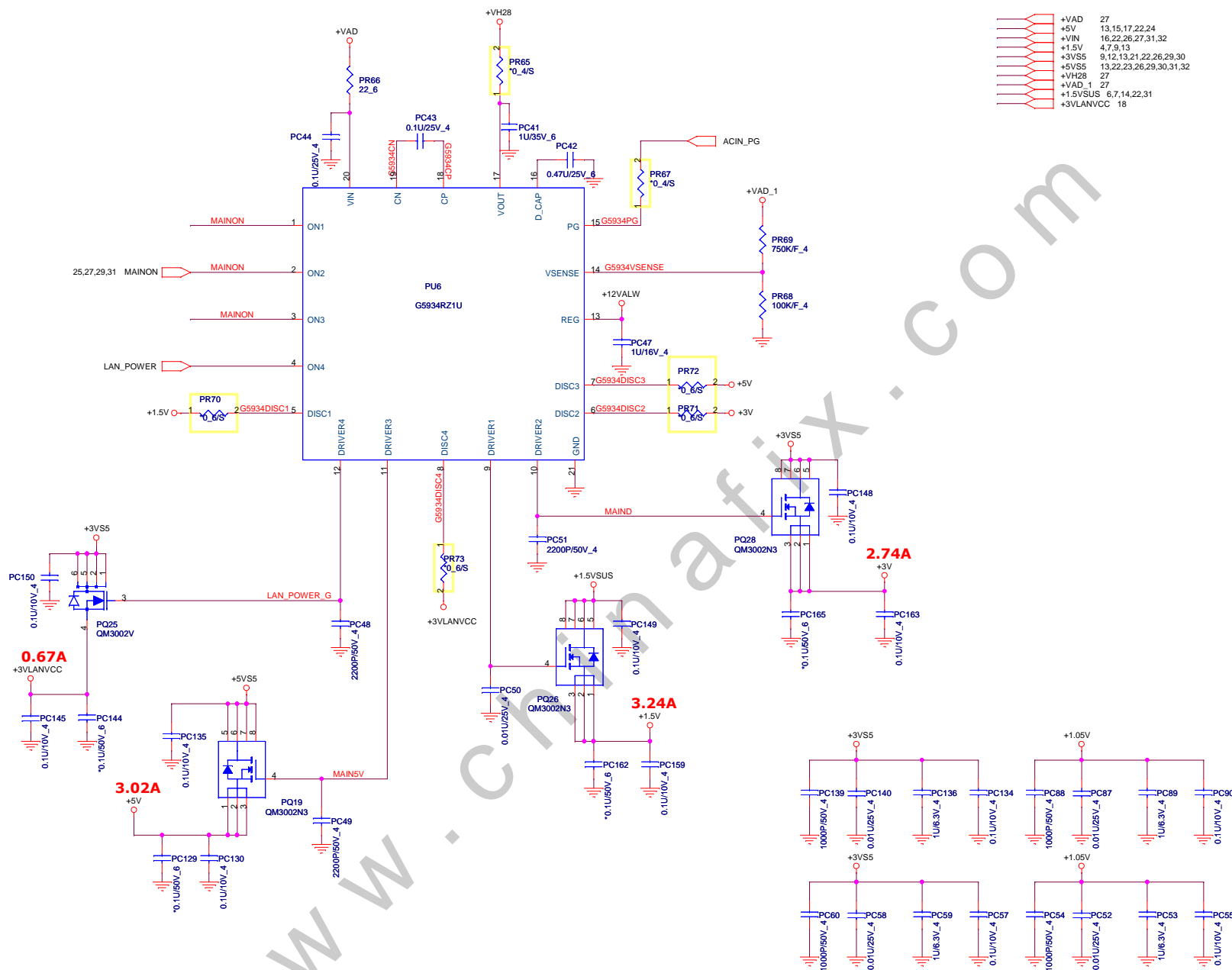

VCCP1.05V

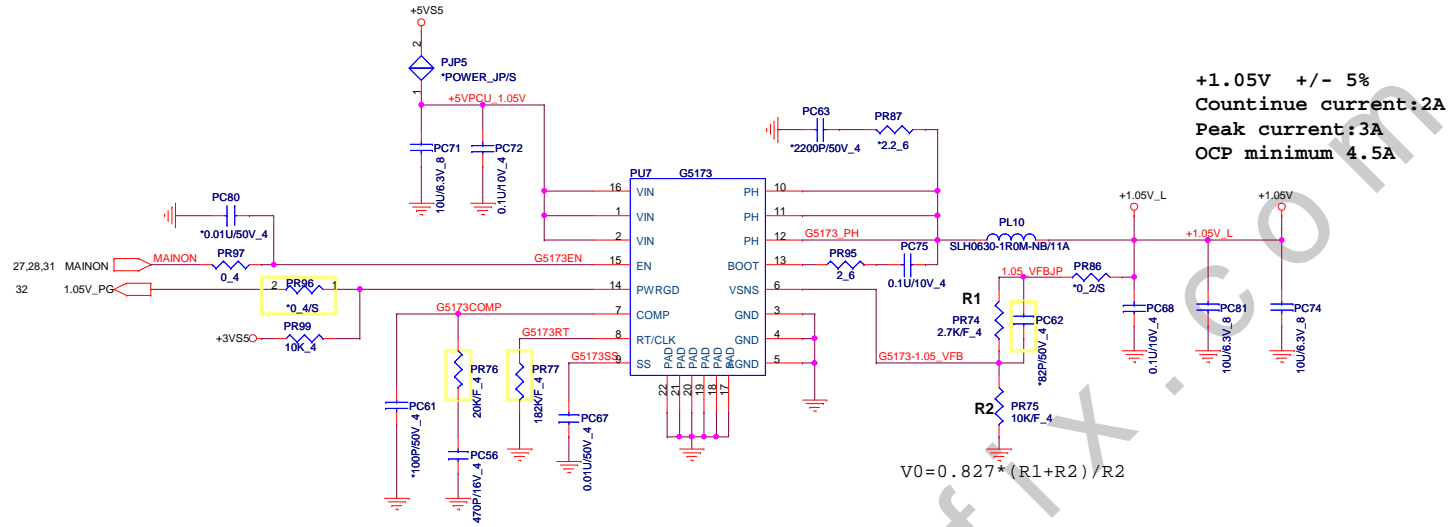

www.chinafix.com

Quanta Computer Inc. PROJECT : Miata (NM3)		
Size	Document Number	Rev
	1.05V(G5173)/1.2V(G9661)	1A
Date:	Thursday, April 07, 2011	Sheet 29 of 32

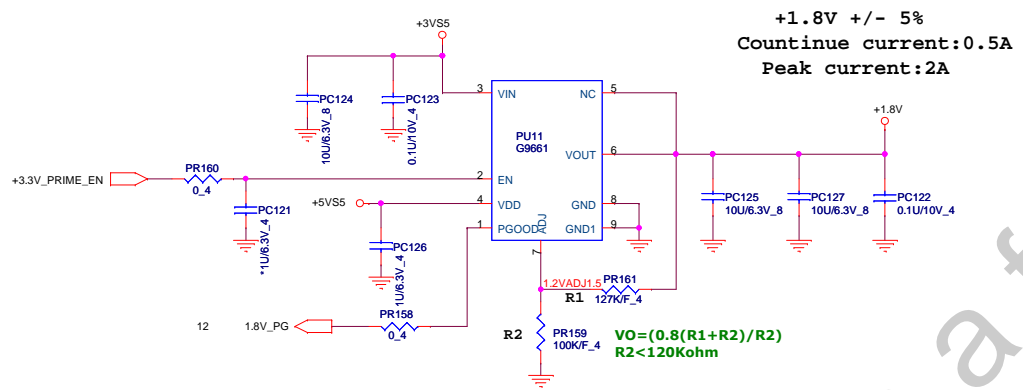

www.chinafix.com



+1.5V +/- 5%
Countinue curr
Peak current:8
OCP minimum 12

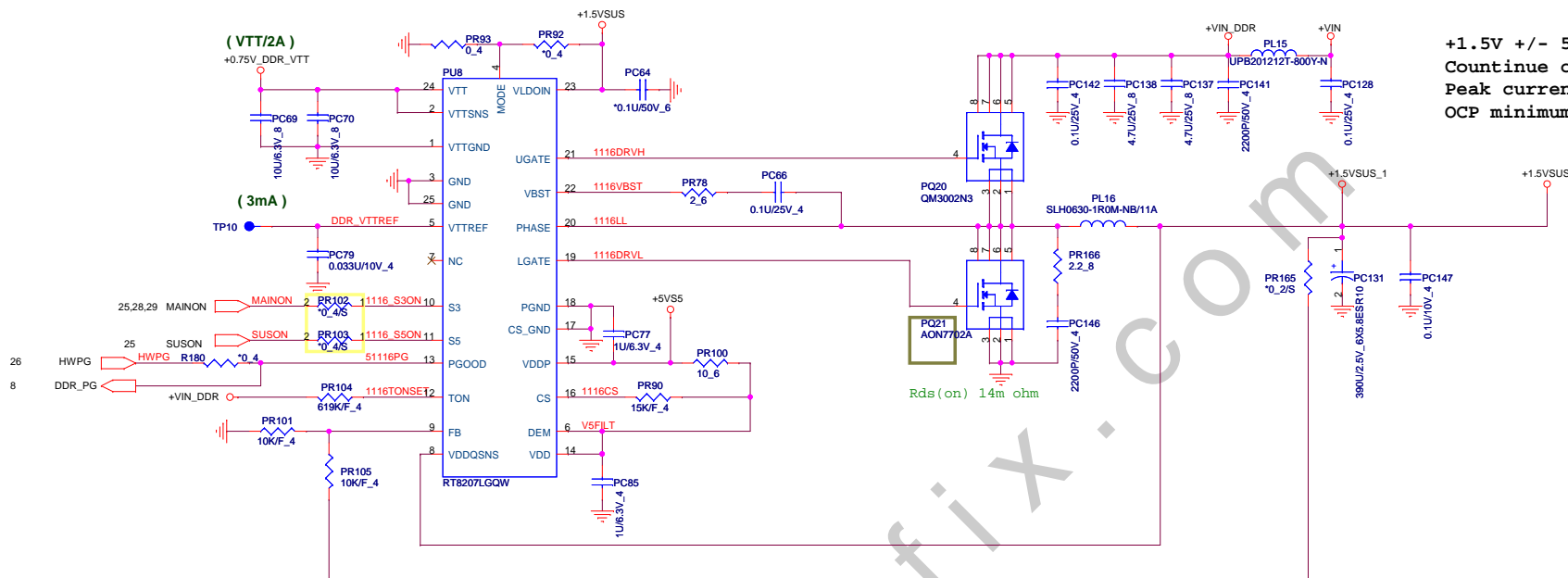

www.chinafix.com

		Quanta Computer Inc.	
		PROJECT : Miata(NM3)	
Size	Document Number	DDR2 +1.5VSUS/+0.75V	Rev. 1A
Date:	Friday, April 08, 2011	Sheet	31 of 32



+CPUV
 Countinue current:5A
 Peak current:6.1A
 OCP minimum:9A

+GFXORE Volt +/- 5%
 Countinue current:1.5A
 Peak current:2A
 OCP minimum:3A

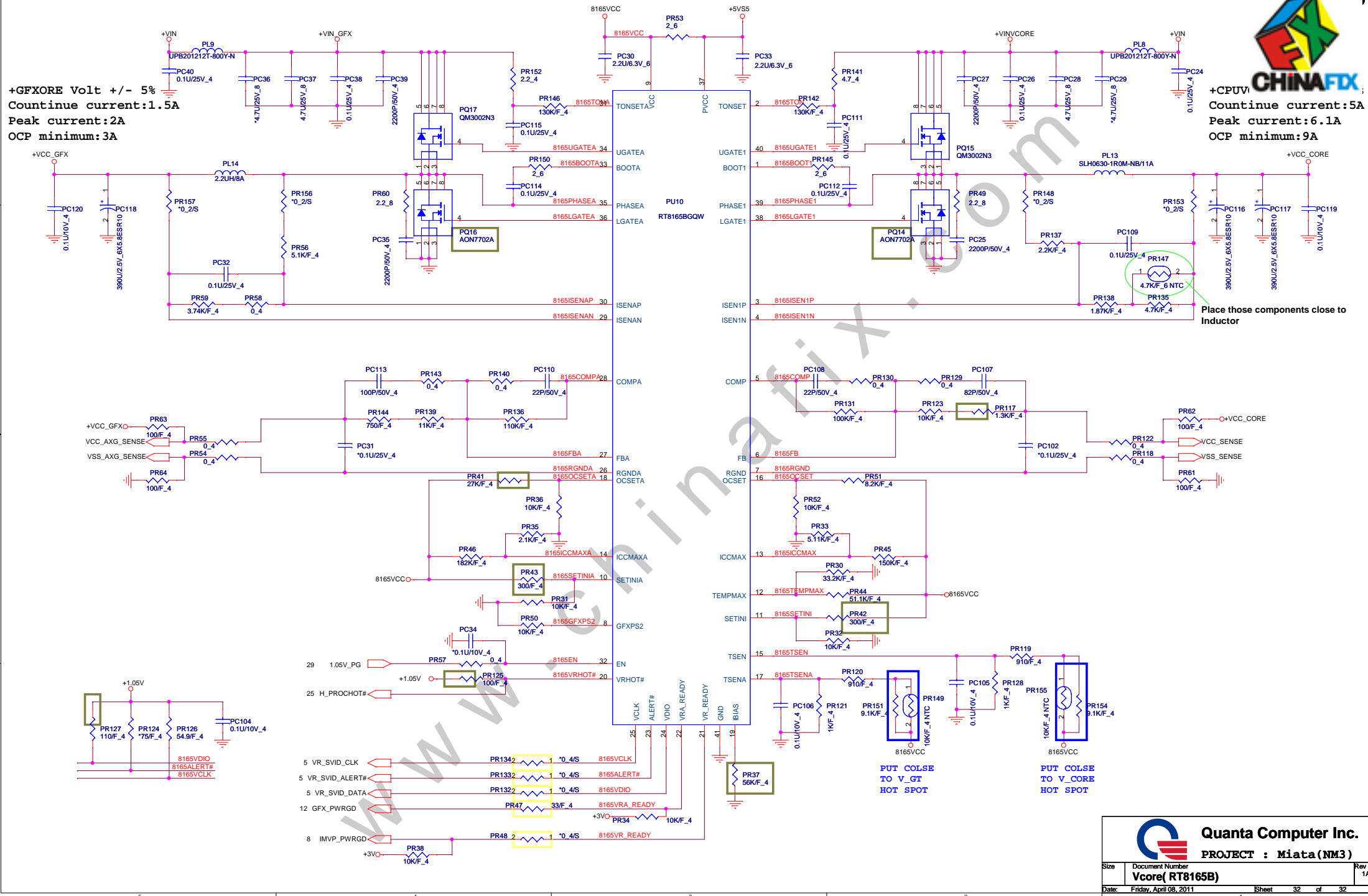

Quanta Computer Inc.
 PROJECT : Miata (NM3)

Size	Document Number	Rev
	Vcore (RT8165B)	1A
Date:	Friday, April 08, 2011	Sheet 32 of 32