

TABLE OF CONTENTS

PAGE

- 5- DC& BATTERY CHARGER
- 6- SELECT & BATTERY CONN
- 7- SYSTEM POWER(3V/5V)
- 8- SYSTEM POWER(+V1.05M_LAN/+V1.5)
- 9- SYSTEM POWER(+V1.8S)
- 10- SYSTEM POWER(+VCCP)
- 11- CPU POWER(VCC_CORE)
- 12- GRAPHIC POWER(+VGFX_CORE)
- 13- POWER(SLEEP)
- 14- POWER(SEQUENCE)
- 15- CLOCK_GENERATOR
- 16- FAN
- 17-ARRANDALE1
- 18-ARRANDALE2
- 19-ARRANDALE3 & XDP
- 20-ARRANDALE4
- 21-ARRANDALE5
- 22-ARRANDALE6
- 23- DDR3-DIMM0
- 24- DDR3-DIMM1
- 25- PCH1
- 26- PCH2
- 27- PCH3
- 28- PCH4
- 29- PCH5
- 30- PCH6
- 31- PCH7-POWER
- 32- PCH8-POWER
- 33- PCH9

PAGE

- 34- CRT / DISPLAY PORT CNTR
- 35- LCM & CAMERA
- 36- SATA & ODD CNTR
- 37- LEFT USB & ESATA COMBO
- 38- BLUE TOOTH & FINGER PRINTER CNTR
- 39- ACCELEMOTOR
- 40- KBC & SPI
- 41- KEYBOARD & STICK POINT
- 42- SUPER I/O
- 43- TPM & MDC
- 44- LAN INTERFACE
- 45- LAN RJ45 CNTR
- 46- WWAN & WLAN & SIM
- 47- DOCKING CNTR
- 48- CNTR FOR DAUGHTER BOARD
- 49- SCREW & EMI
- 50- CARD READER DB-1
- 51- CARD READER DB-2
- 52- ODD DB
- 53- SERIAL DB
- 54- POWER BUTTON DB
- 55- EXPRESS CARD & Audio DB-1
- 56- EXPRESS CARD & Audio DB-2
- 57- EXPRESS CARD & Audio DB-3
- 58- EXPRESS CARD & Audio DB-4
- 59- EXPRESS CARD & Audio DB-5
- 60- CAP SENSOR BOARD DB(SMSC) 14"
- 61- CAP SENSOR BOARD DB(SMSC) 15"

INVENTEC

TITLE			
<i>Diesel10 - UMA</i>			
Page List			
SIZE	CODE	DOC. NUMBER	REV
A3	CS	1310A2326601-0-MTR	A01
SHEET		OF	61
2			

CHANGE by Y.S. Chu 25-Jan-2010

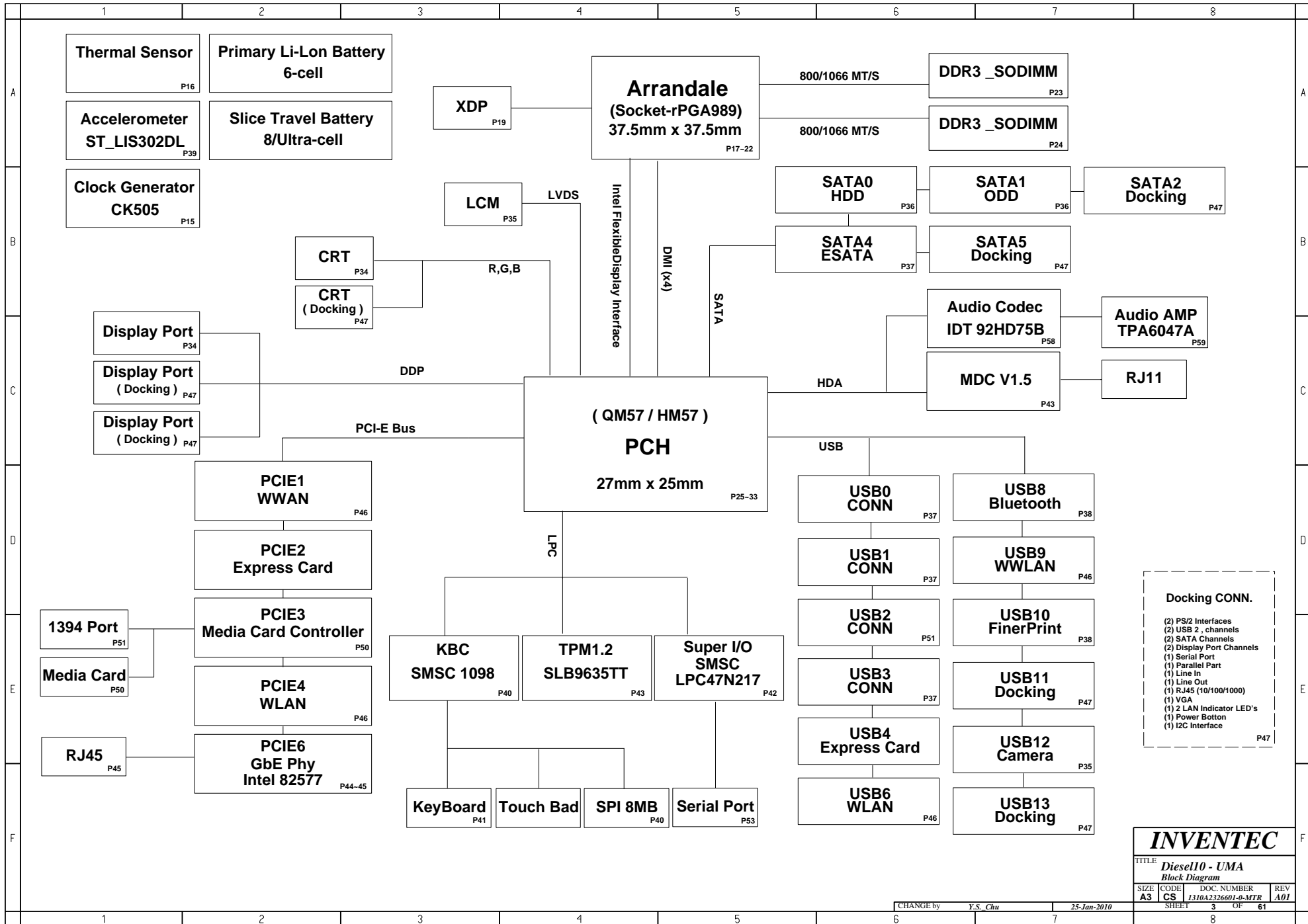

- Docking CONN.**
- (2) PS/2 Interfaces
 - (2) USB 2. channels
 - (2) SATA Channels
 - (2) Display Port Channels
 - (1) Serial Port
 - (1) Parallel Port
 - (1) Line In
 - (1) Line Out
 - (1) RJ45 (10/100/1000)
 - (1) VGA
 - (1) 2 LAN Indicator LED's
 - (1) Power Button
 - (1) I2C Interface

INVENTEC			
TITLE Diesel10 - UMA			
Block Diagram			
SIZE	CODE	DOC. NUMBER	REV
A3	CS	1310A2326601-0-MTR	A01
CHANGE by		Y.S. Chu	25-Jan-2010
SHEET		3	OF 61

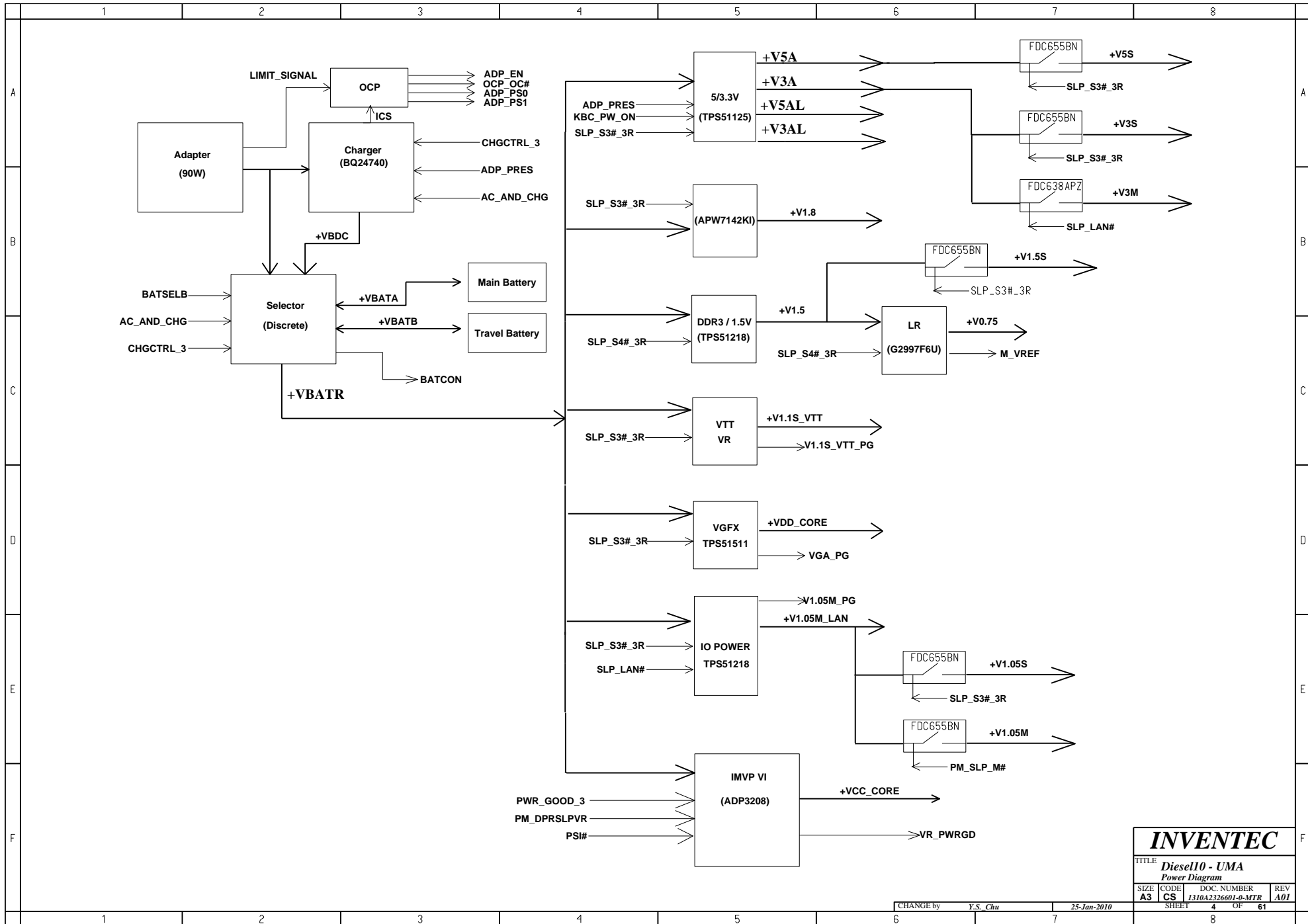

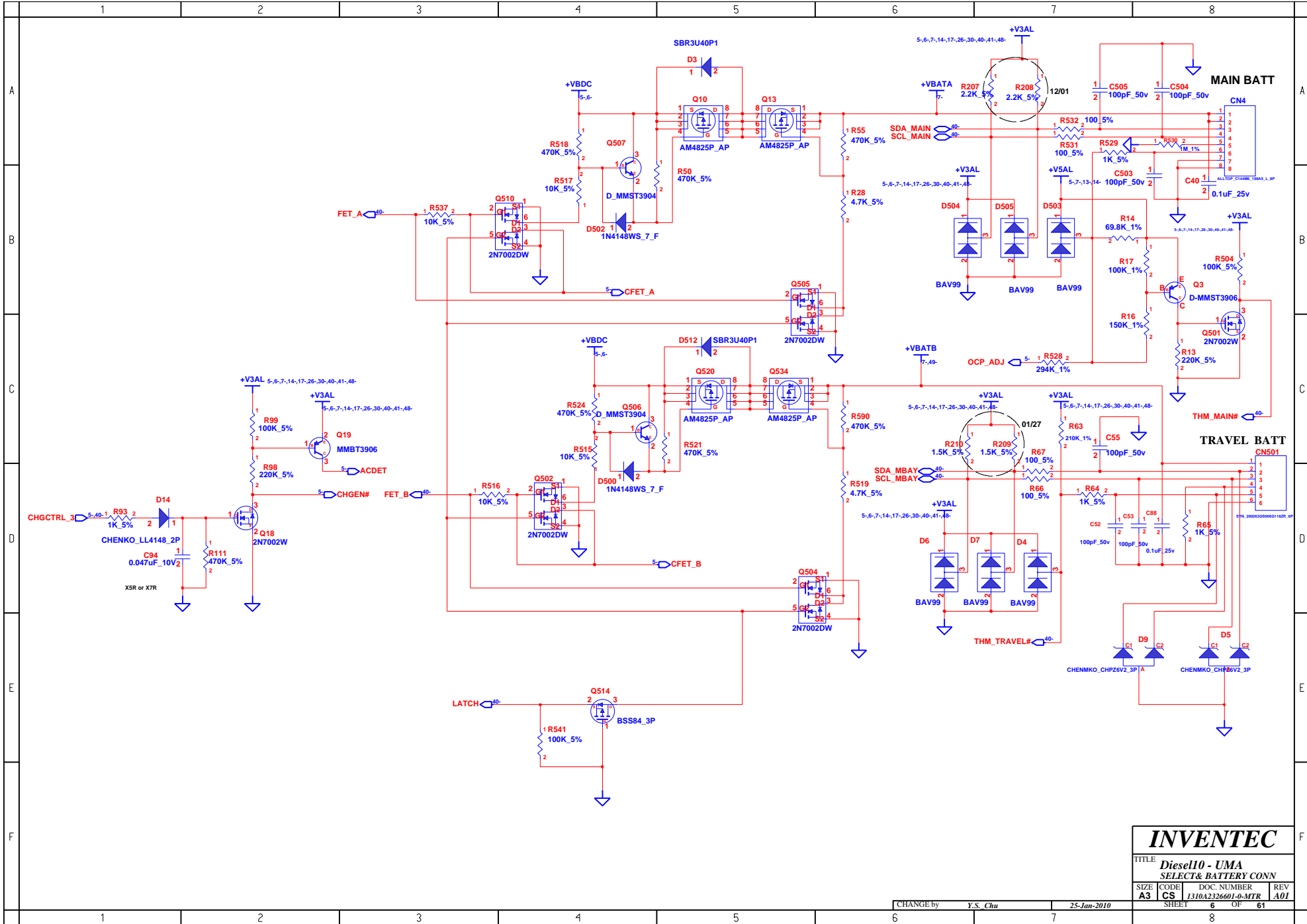

INVENTEC			
TITLE Diesel10 - UMA			
SELECT & BATTERY CONN			
SIZE A3	CODE CS	DOC. NUMBER 1310A2326601-0-MTR	REV A01
CHANGE by Y.S. Chu		25-Jan-2010	
SHEET 6		OF 61	

<http://sualaptop365.edu.vn>

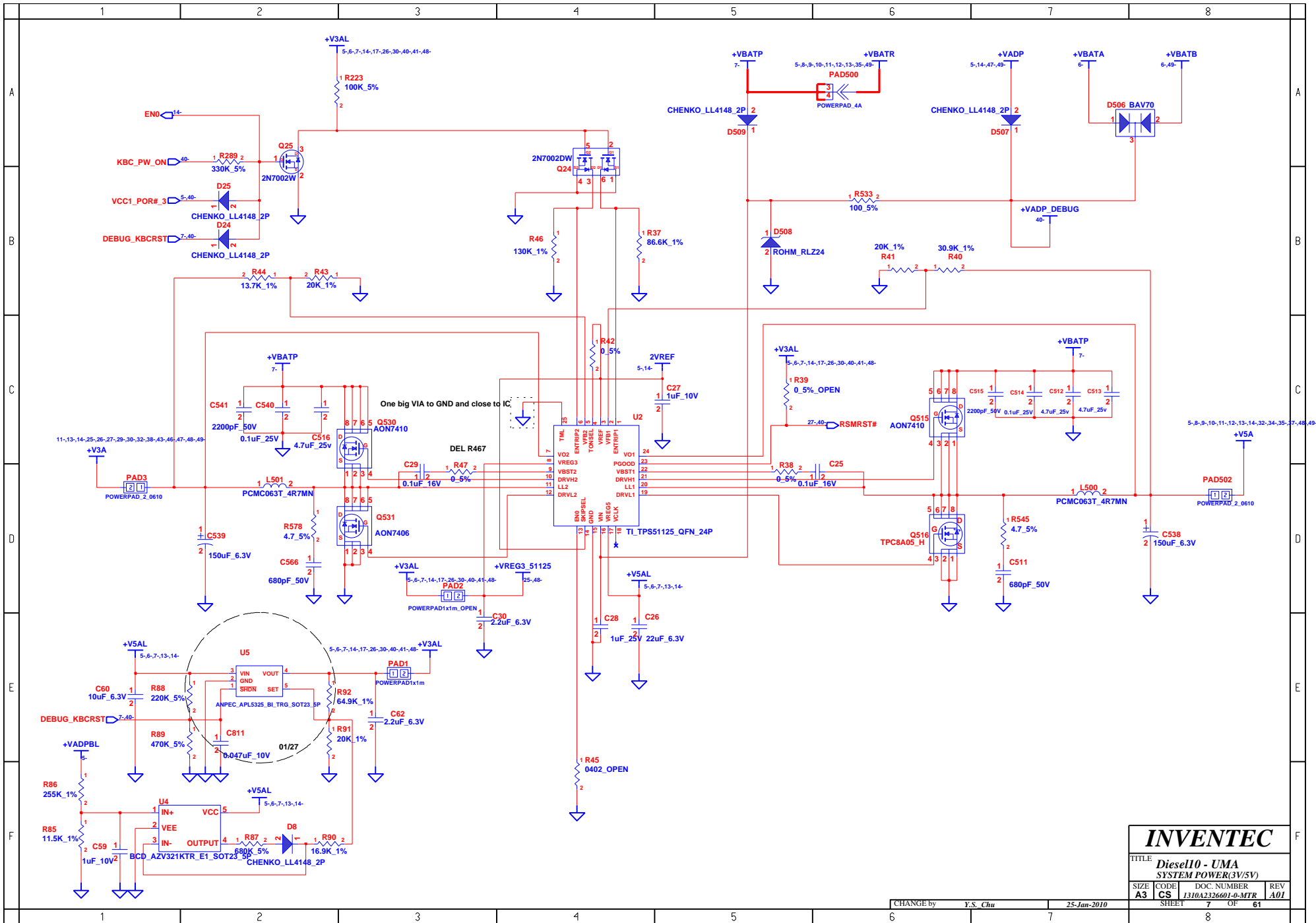

INVENTEC			
TITLE Diesel10 - UMA SYSTEM POWER(3V/5V)			
SIZE A3	CODE CS	DOC. NUMBER 1310A2326601-0-MTR	REV A01
CHANGE by Y.S. Chu		25-Jan-2010	
SHEET 7		OF 61	

<http://sualaptop365.edu.vn>

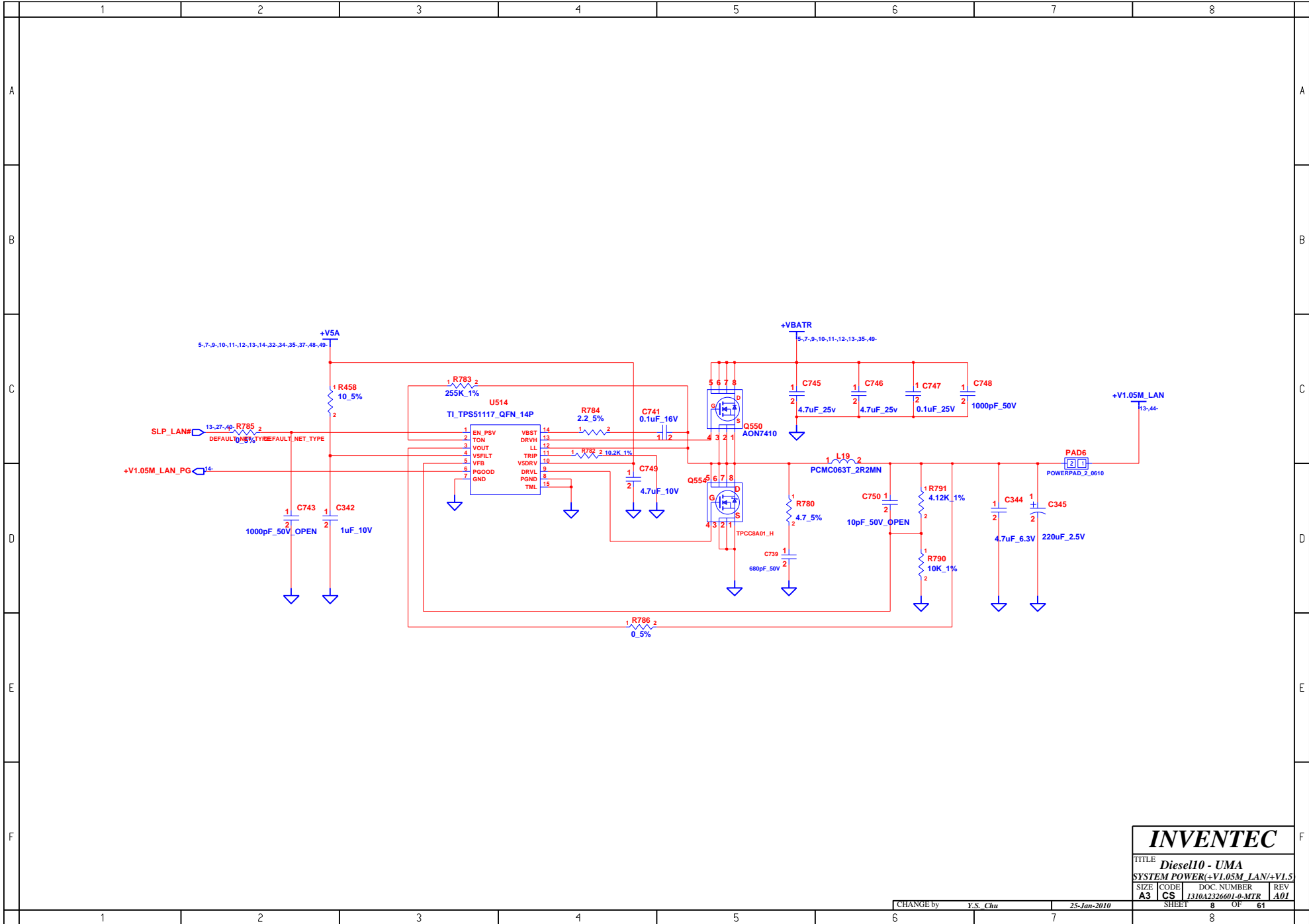

INVENTEC			
TITLE Diesel10 - UMA			
SYSTEM POWER(+V1.05M_LAN/+V1.5			
SIZE A3	CODE CS	DOC. NUMBER 1310A2326601-0-MTR	REV A01
CHANGE by Y.S. Chu		25-Jan-2010	
SHEET 8		OF 61	

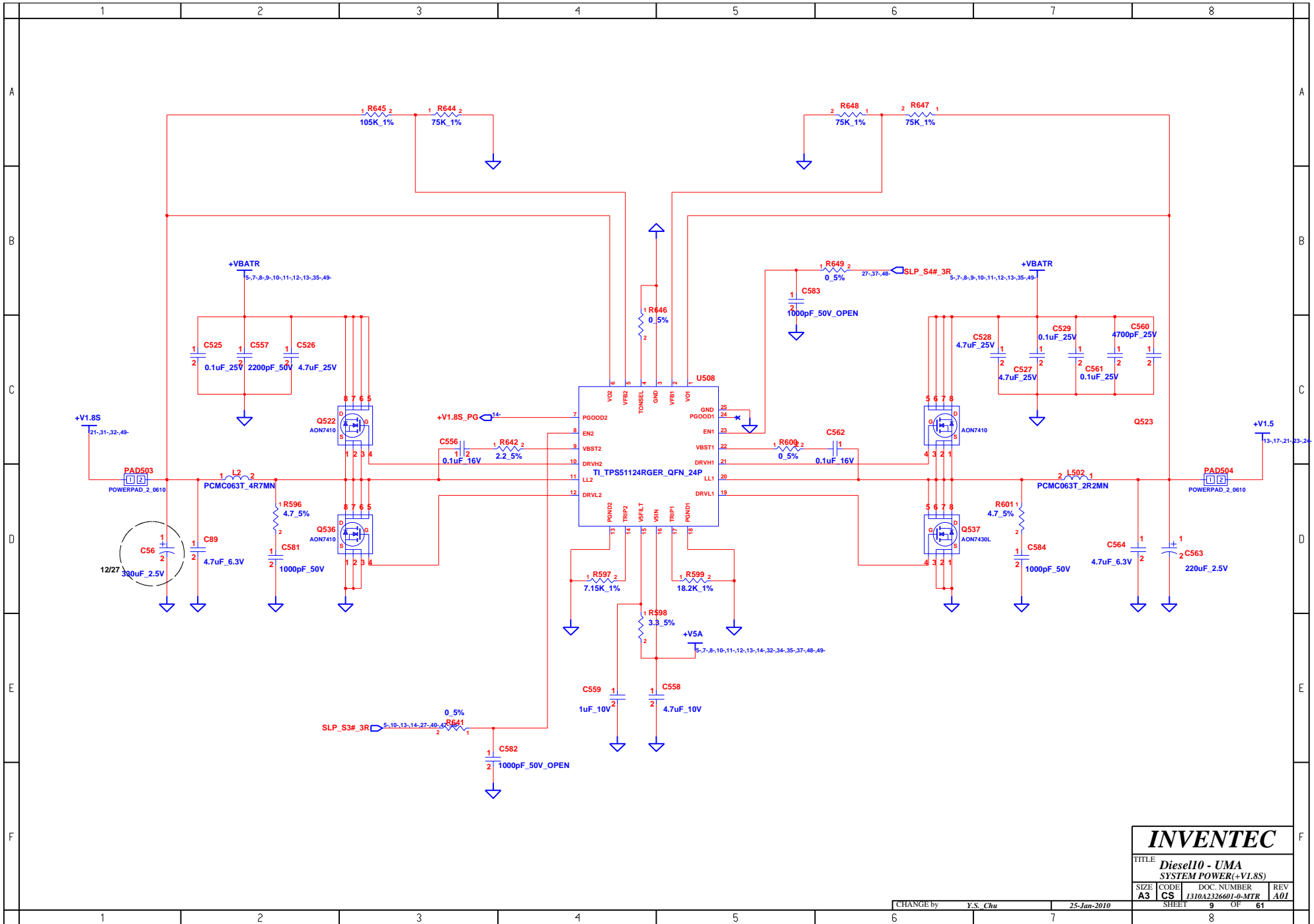

INVENTEC			
TITLE Diesel10 - UMA SYSTEM POWER(+V1.8S)			
SIZE A3	CODE CS	DOC. NUMBER 1310A2326601-0-MTR	REV A01
CHANGE by Y.S. Chu		25-Jan-2010	
SHEET 9		OF 61	

<http://sualaptop365.edu.vn>

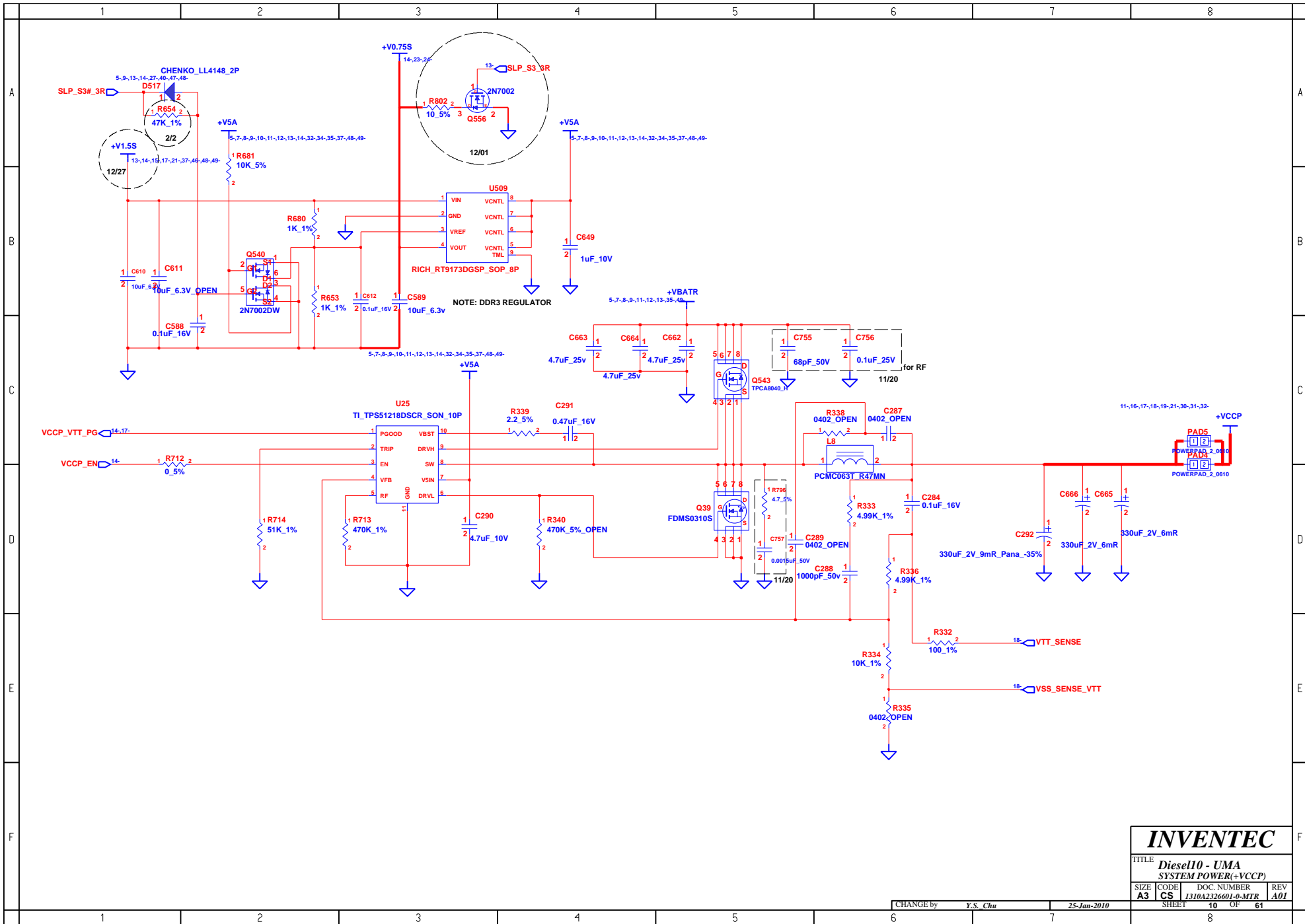

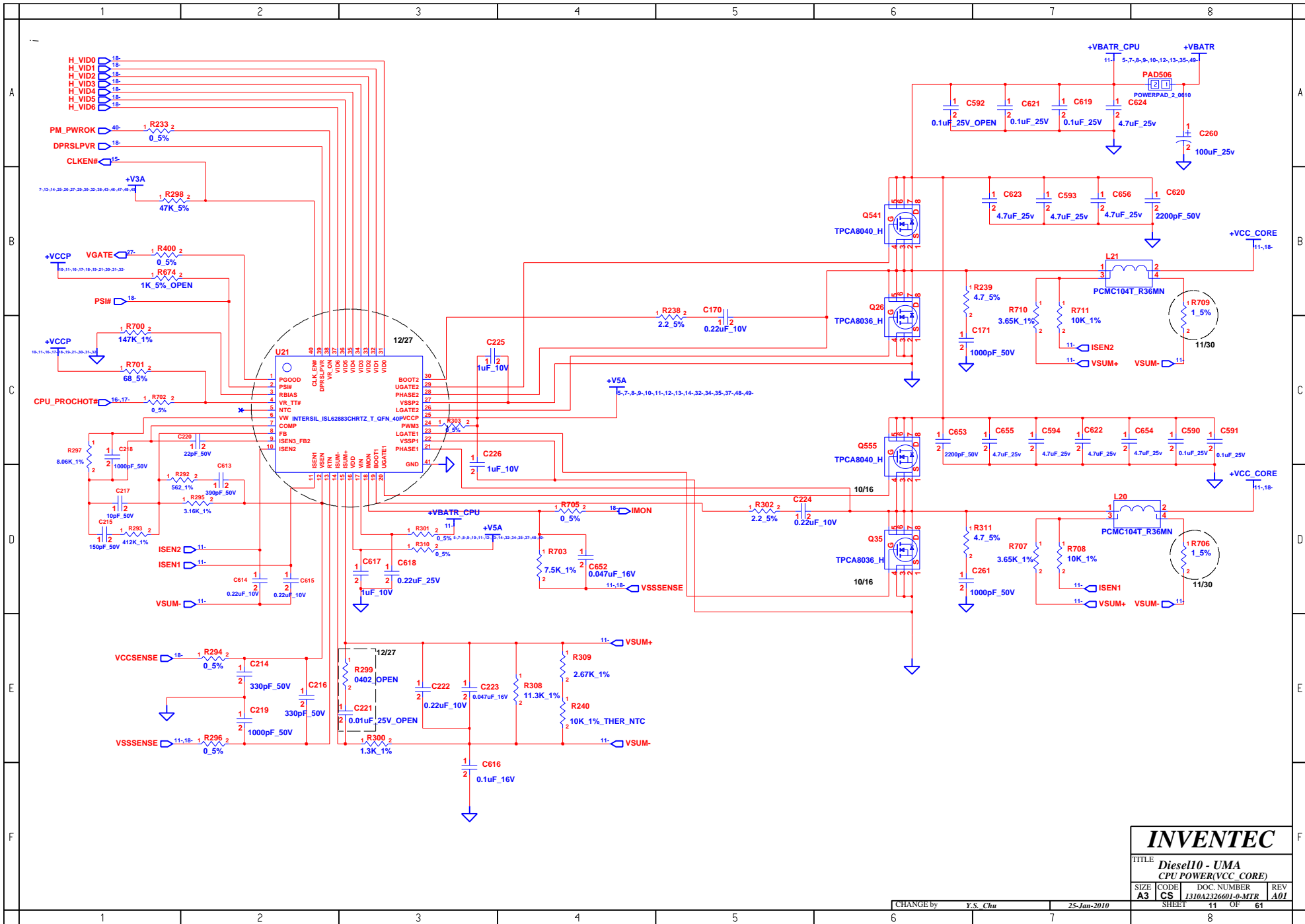

INVENTEC			
TITLE Diesel10 - UMA CPU POWER(VCC_CORE)			
SIZE A3	CODE CS	DOC NUMBER 1310A2326601-p-MTR	REV A01
CHANGE by Y.S. Chu		25-Jan-2010	
SHEET 11		OF 61	

<http://sualaptop365.edu.vn>

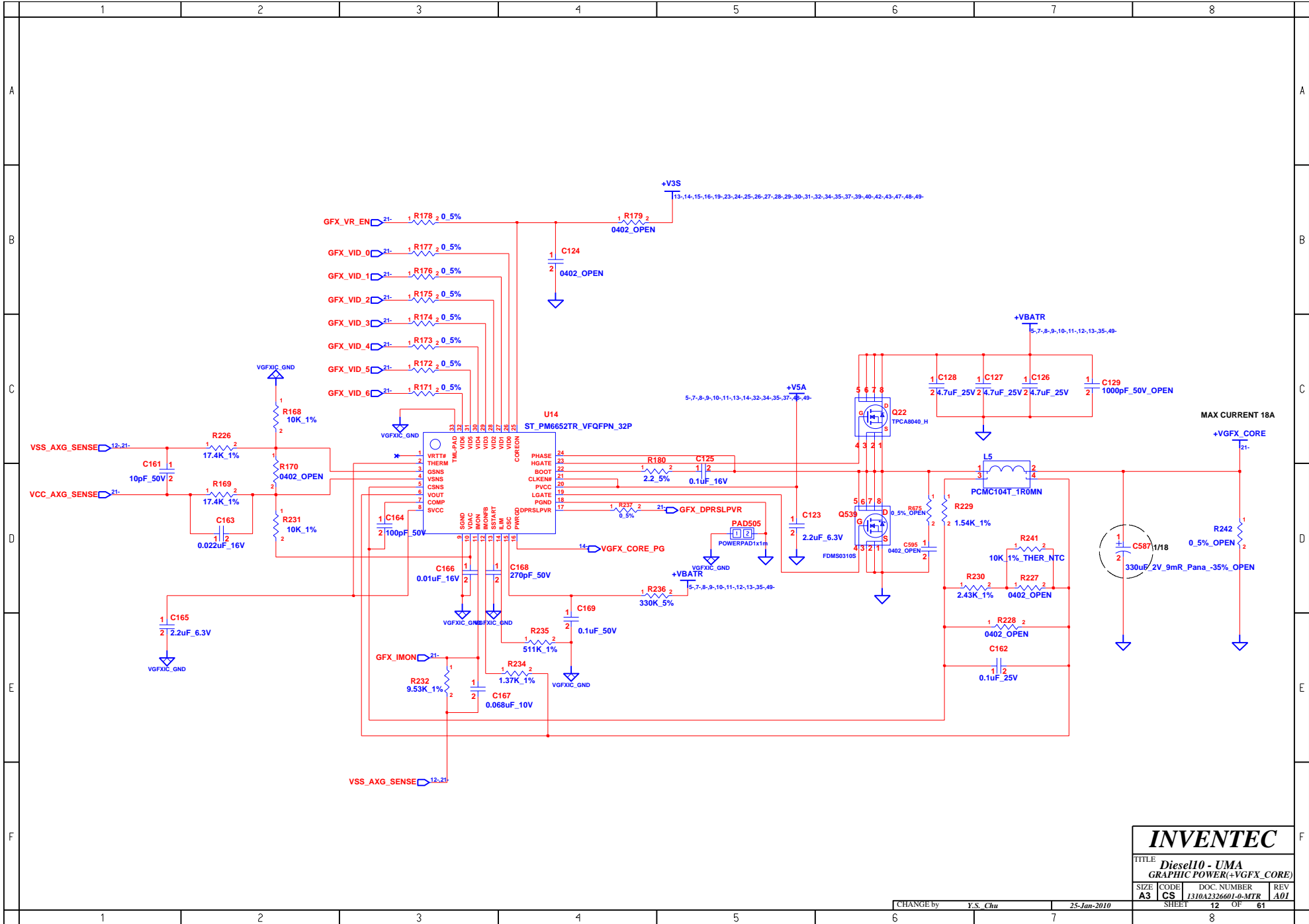

INVENTEC			
TITLE Diesel10 - UMA GRAPHIC POWER(+VGFX_CORE)			
SIZE A3	CODE CS	DOC NUMBER 1310A2326601-0-MTR	REV A01
CHANGE by Y.S. Chu		25-Jan-2010	
SHEET 12		OF 61	

<http://sualaptop365.edu.vn>

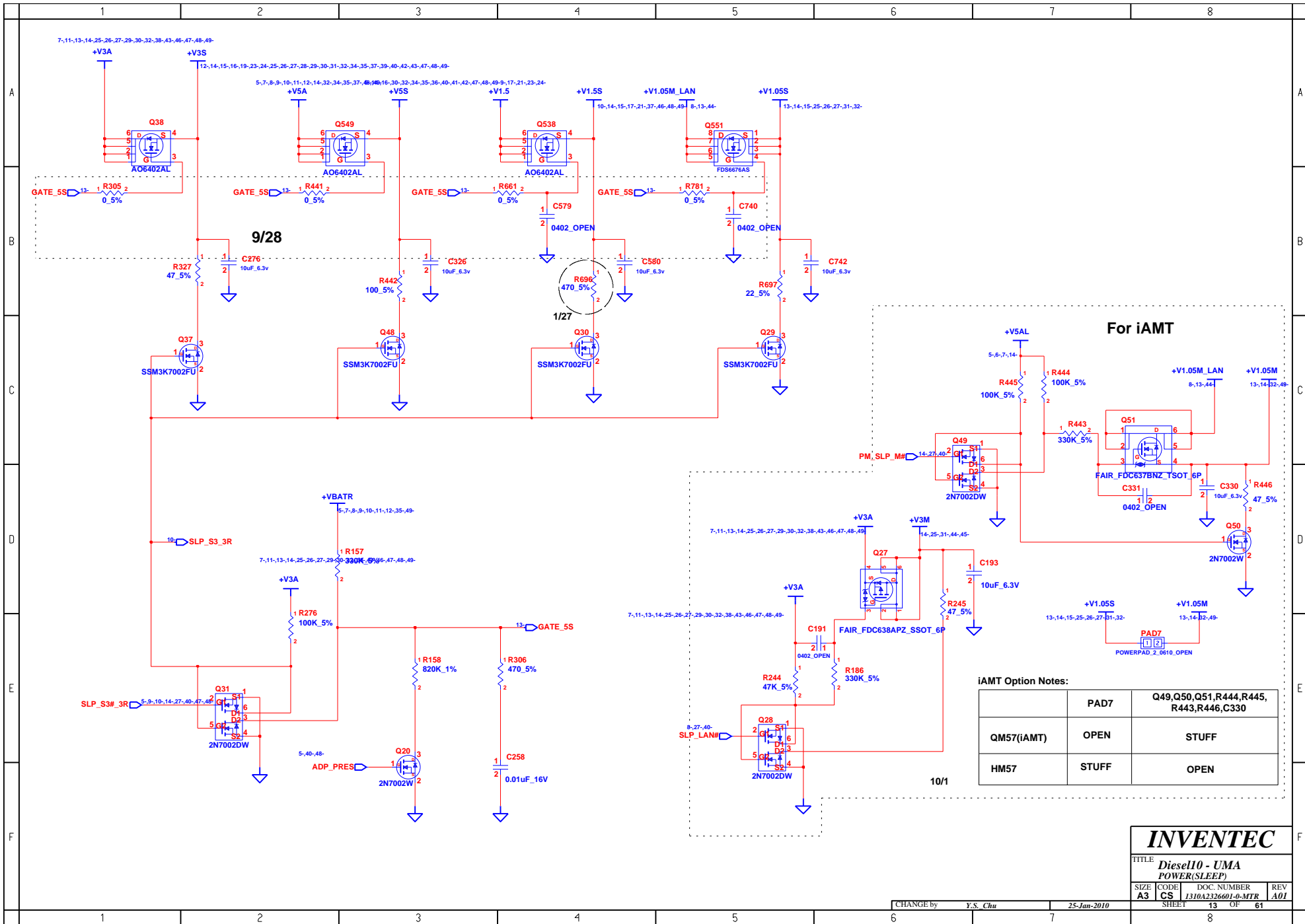

	R1138	R1139
STANDARD POWER	OPEN	STUFF
LOW POWER	STUFF	OPEN

CPU Frequency Select Table

PIN 30	CPU_0 MHz	CPU_1 MHz
0(Default)	133.33	133.33
1	100.00	100.00

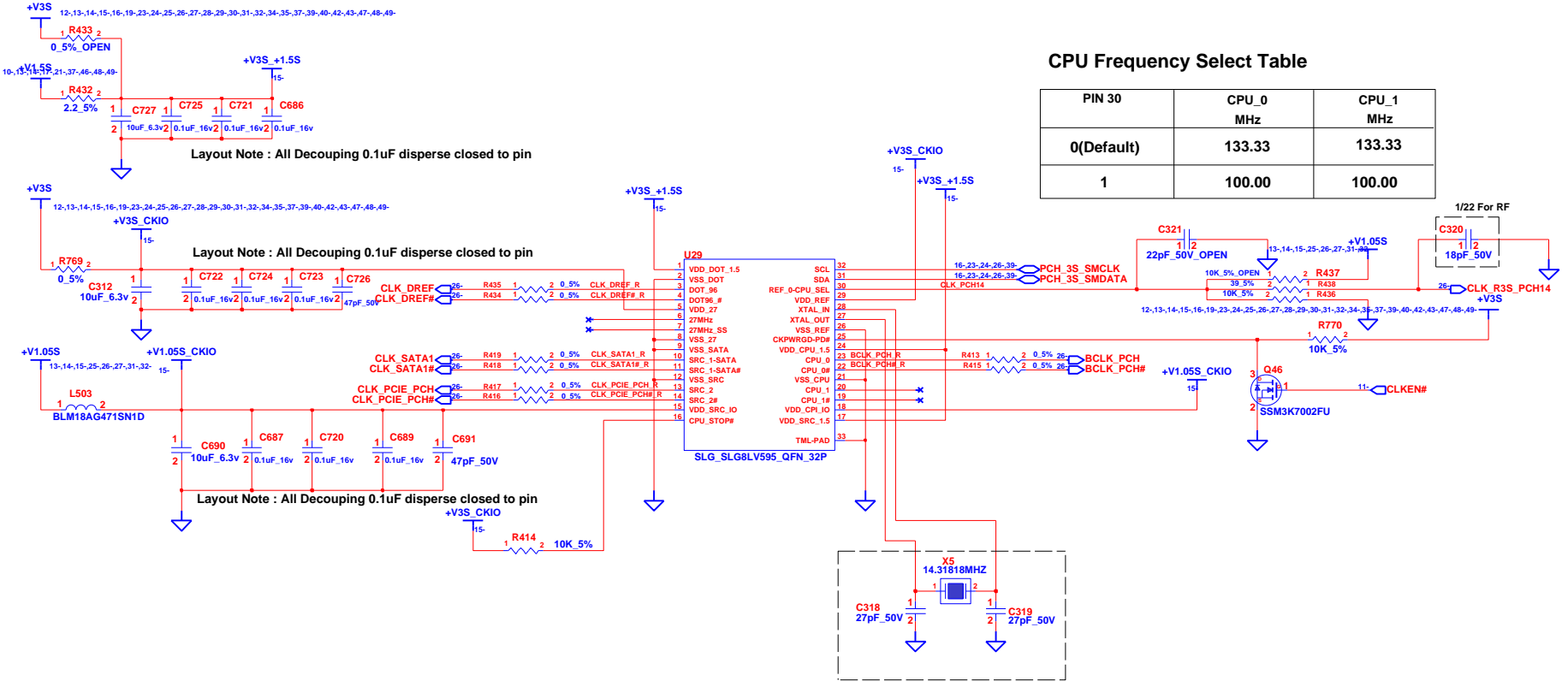

Layout Note: All Decoupling 0.1uF disperse closed to pin

Layout Note: Place close to CLKGEN within 500 mils

INVENTEC			
TITLE Diesel10 - UMA CLOCK GENERATOR			
SIZE A3	CODE CS	DOC NUMBER 1310A232601-p-MTR	REV A01
CHANGE by Y.S. Chu		25-Jan-2010	
SHEET 15		OF 61	

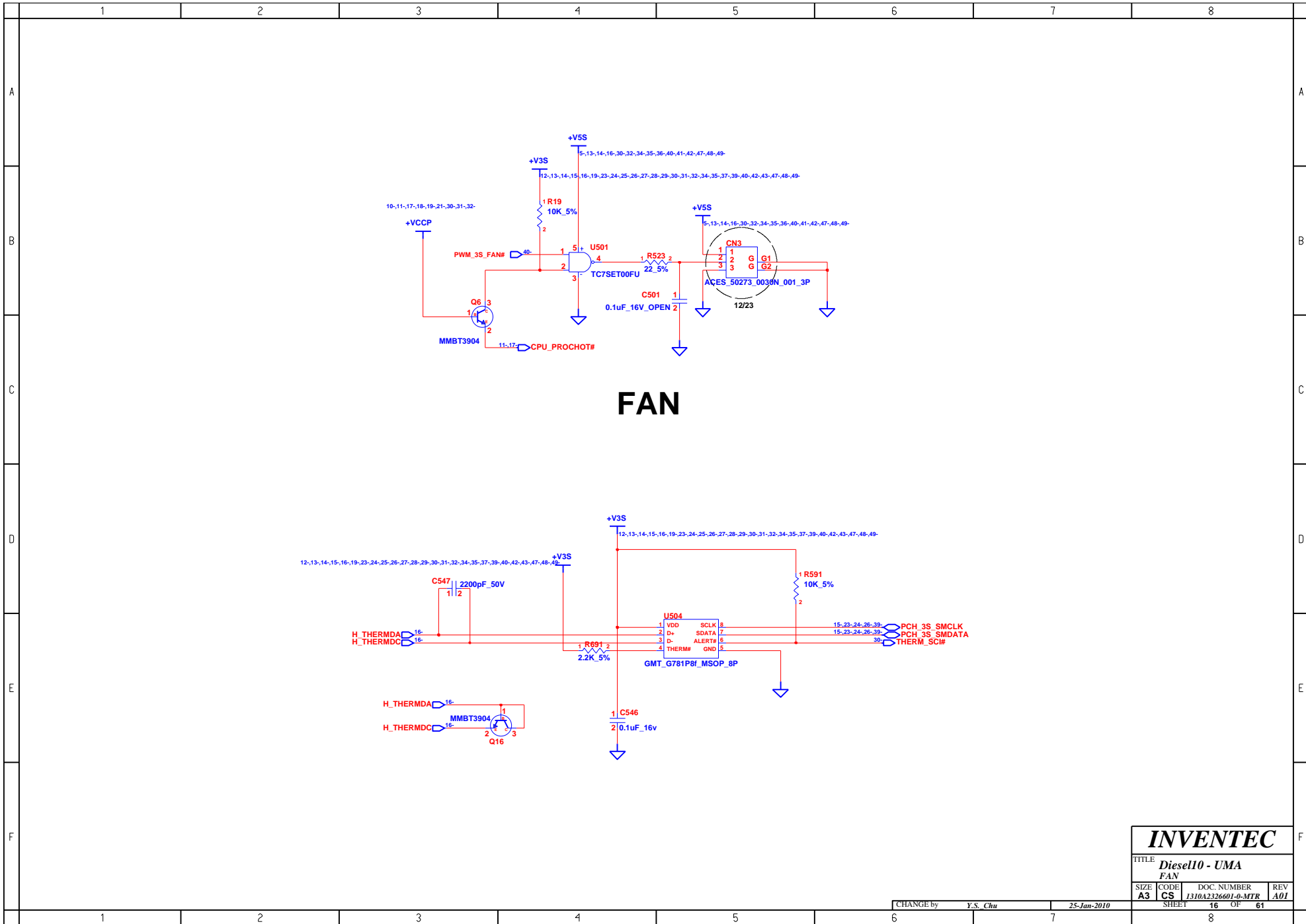

INVENTEC			
TITLE Diesel10 - UMA			
FAN			
SIZE A3	CODE CS	DOC. NUMBER 1310A2326601-0-MTR	REV A01
CHANGE by Y.S. Chu		25-Jan-2010	
SHEET 16		OF 61	

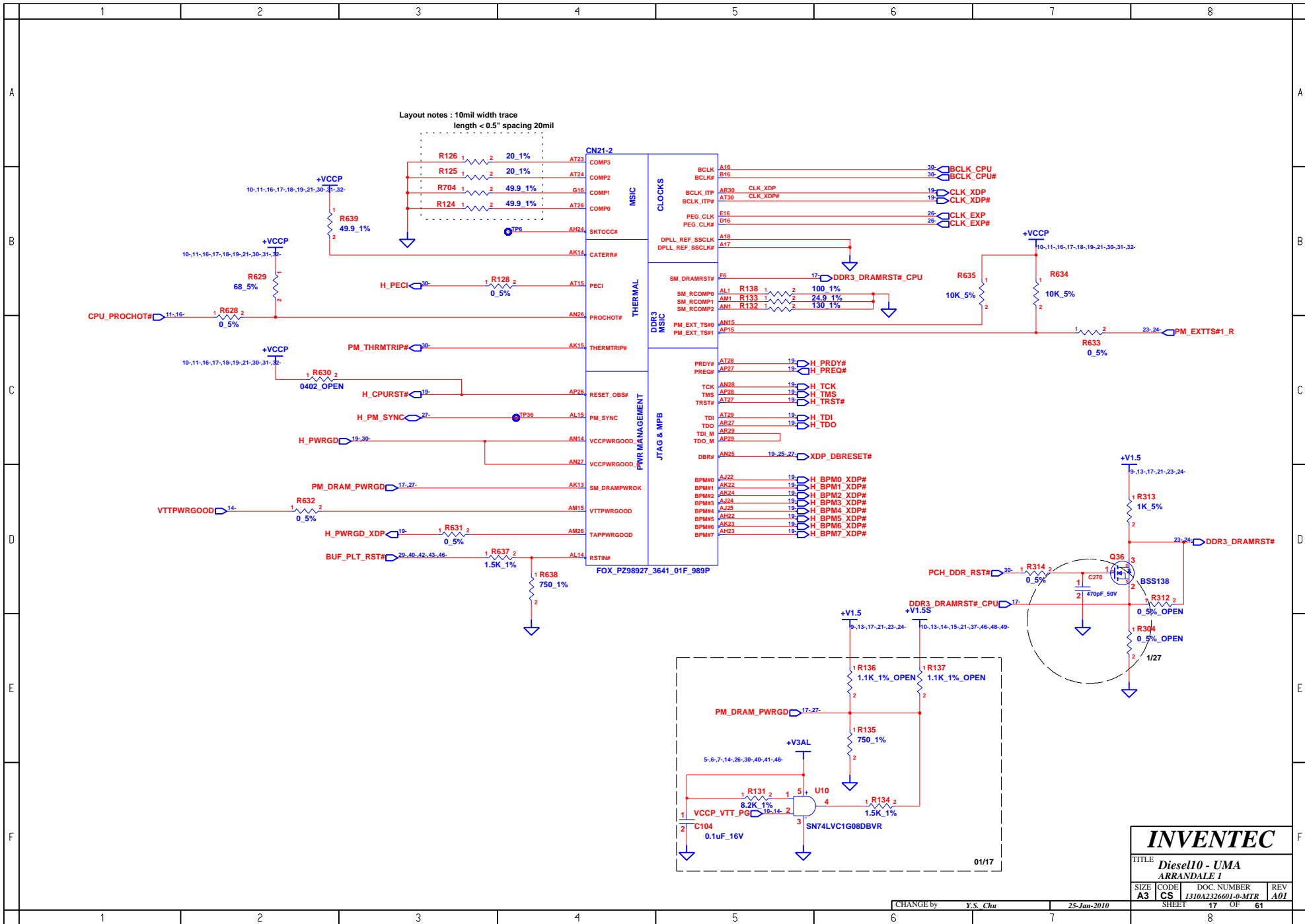

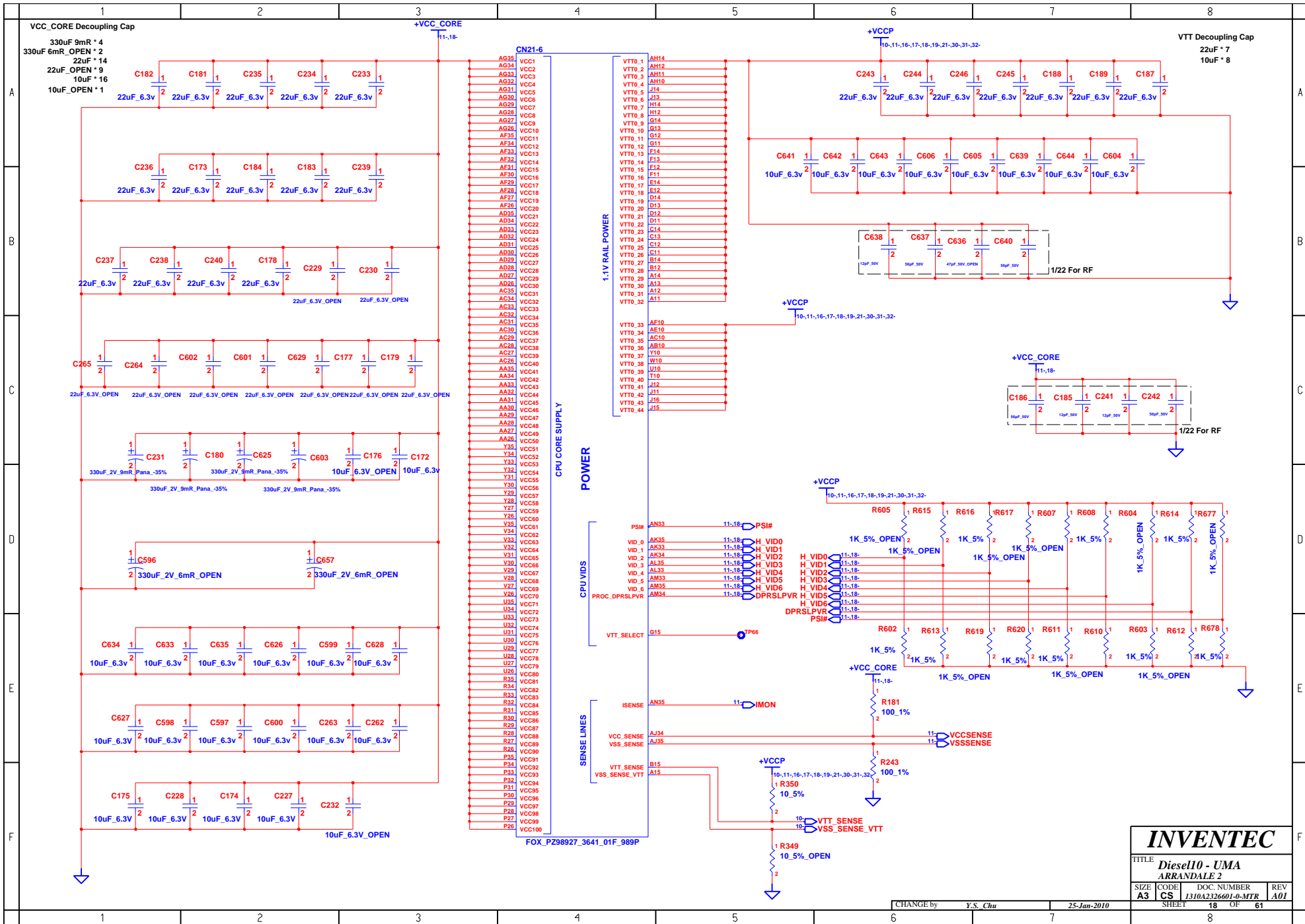

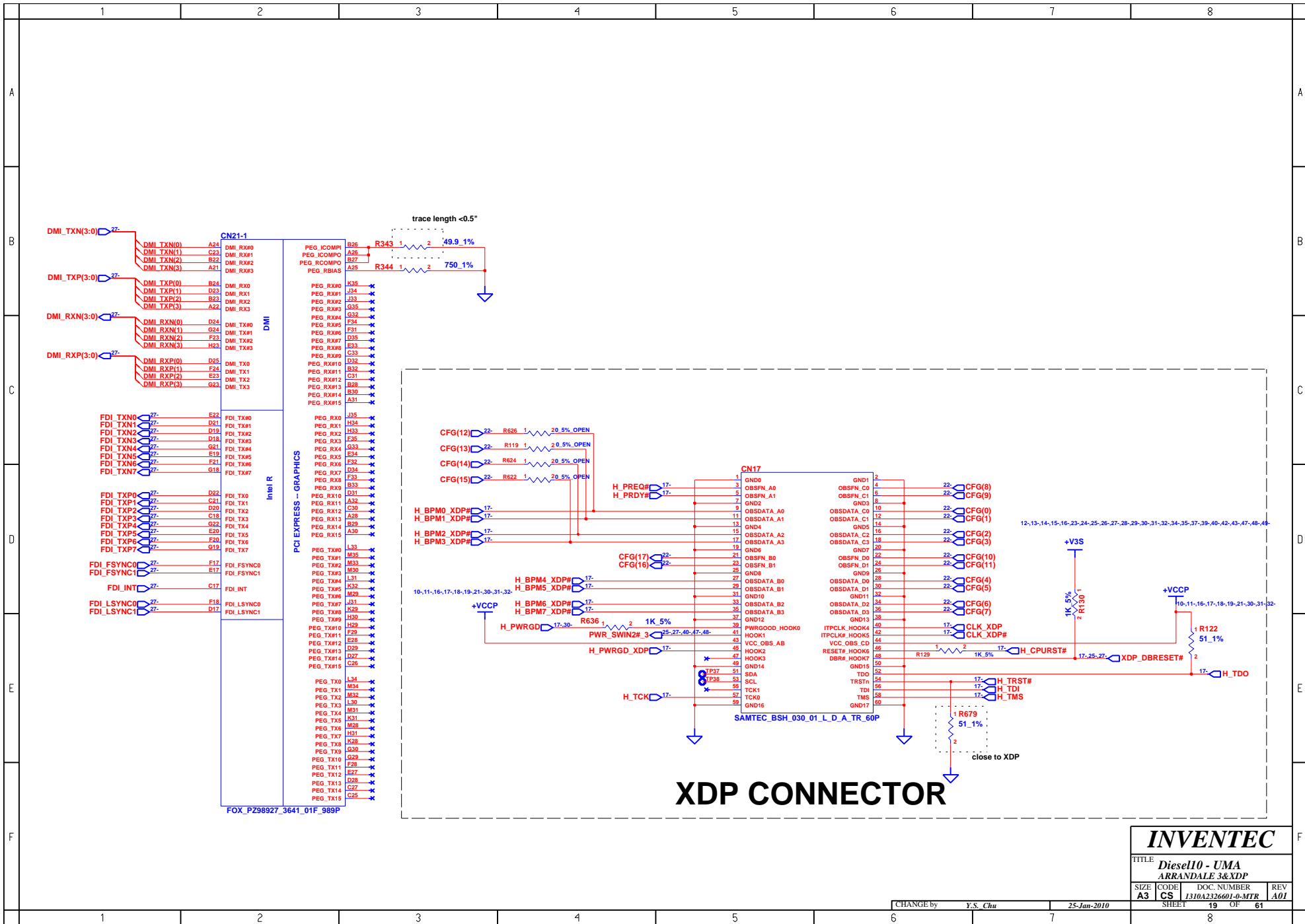

XDP CONNECTOR

INVENTEC

TITLE			
Diesel10 - UMA			
ARRANDALE 3&XDP			
SIZE	CODE	DOC NUMBER	REV
A3	CS	1310A232601-0-MTR	A01
SHEET			OF
19			61

CHANGE by Y.S. Chu 25-Jan-2010

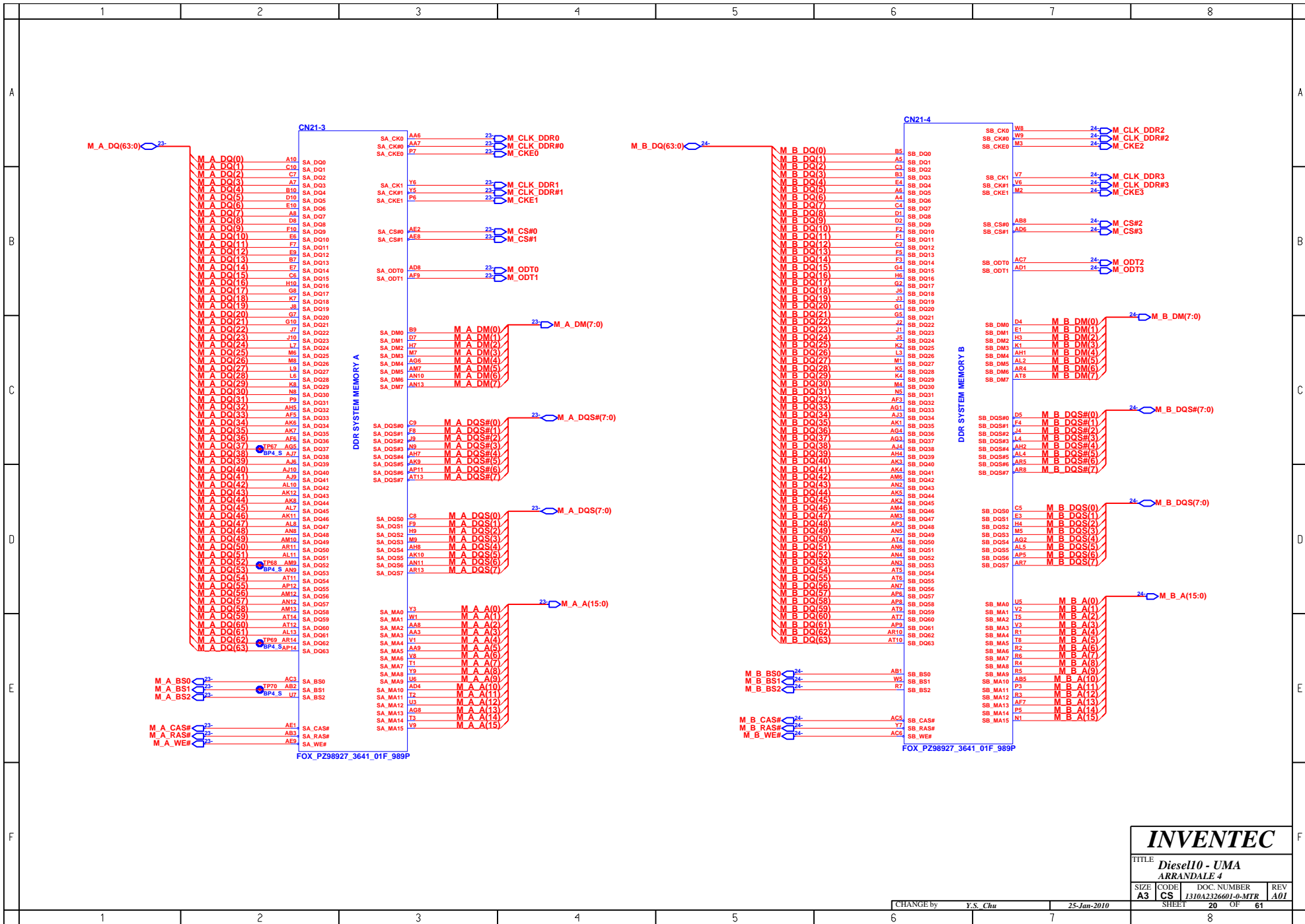

INVENTEC

TITLE: Diesel10 - UMA
ARRANDALE 4

SIZE	CODE	DOC. NUMBER	REV
A3	CS	1310A232601-0-MTR	A01

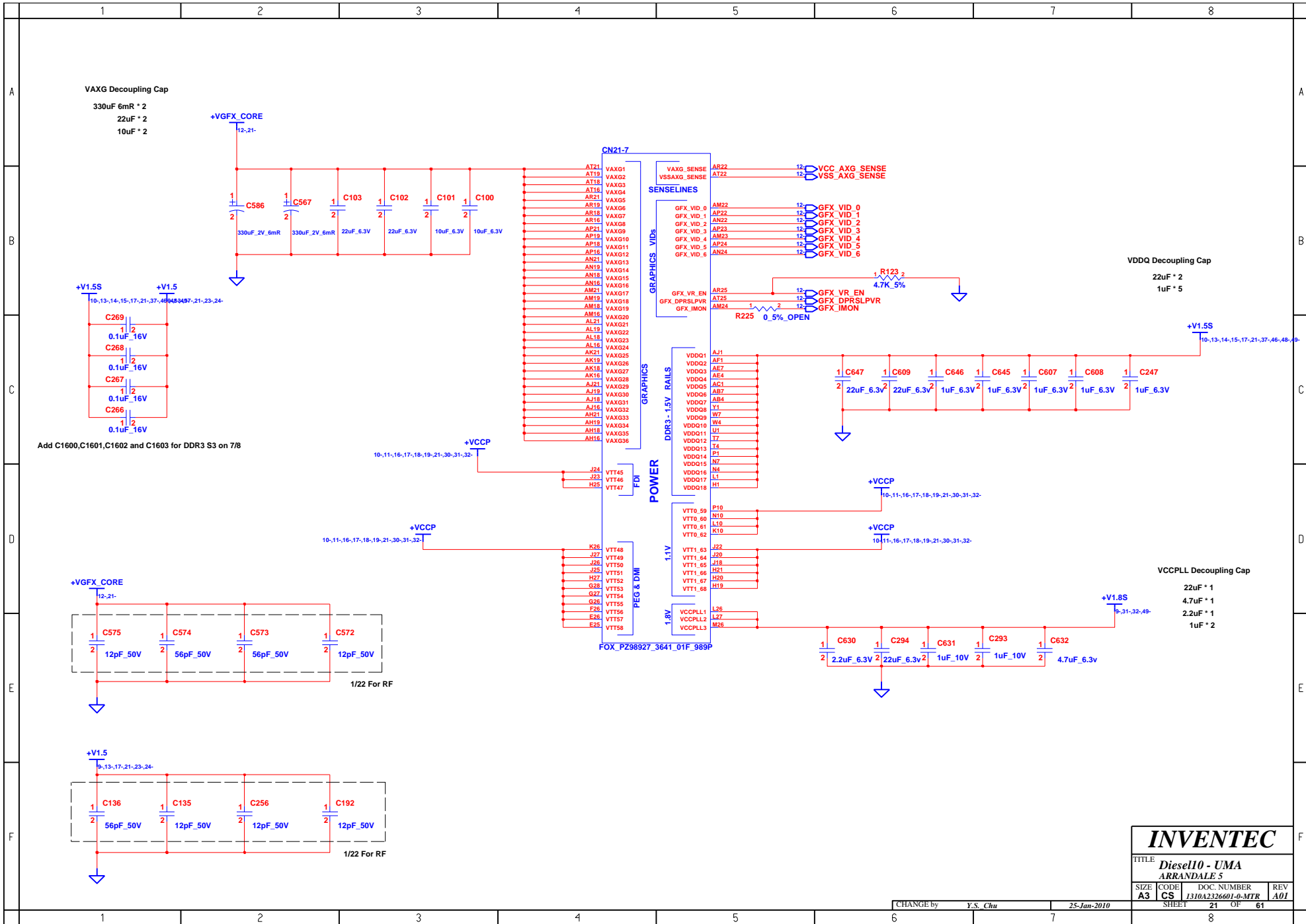

INVENTEC			
TITLE Diesel10 - UMA ARRANDALE 5			
SIZE A3	CODE CS	DOC. NUMBER 1310A2326001-p-MTR	REV A01
CHANGE by Y.S. Chu		25-Jan-2010	
SHEET 21		OF 61	

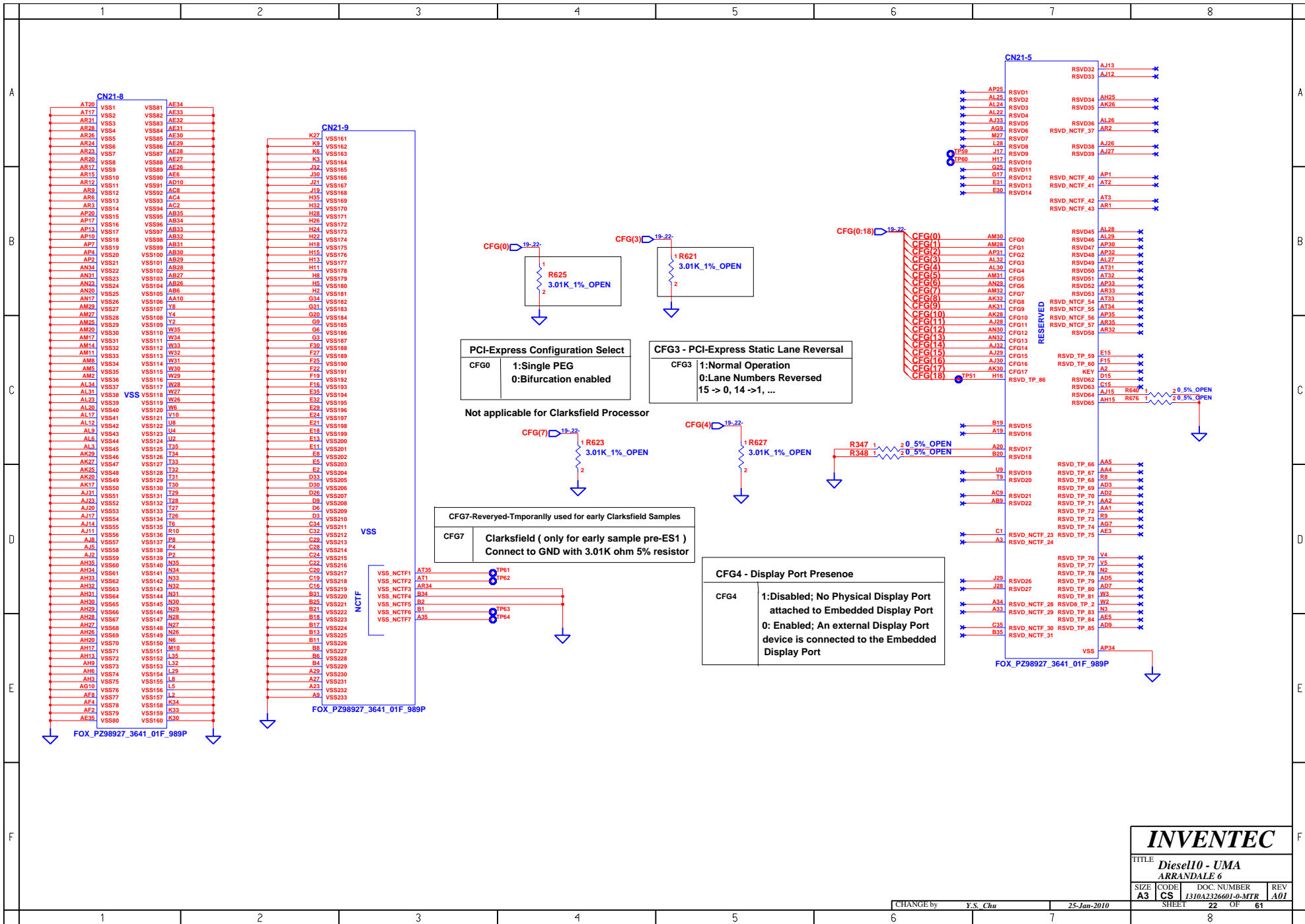

INVENTEC			
TITLE Diesel10 - UMA ARRANDALE 6			
SIZE A3	CODE CS	DOC. NUMBER 1310A2326601-0-MTR	REV A01
CHANGE by Y.S. Chu		25-Jan-2010	
SHEET 22		OF 61	

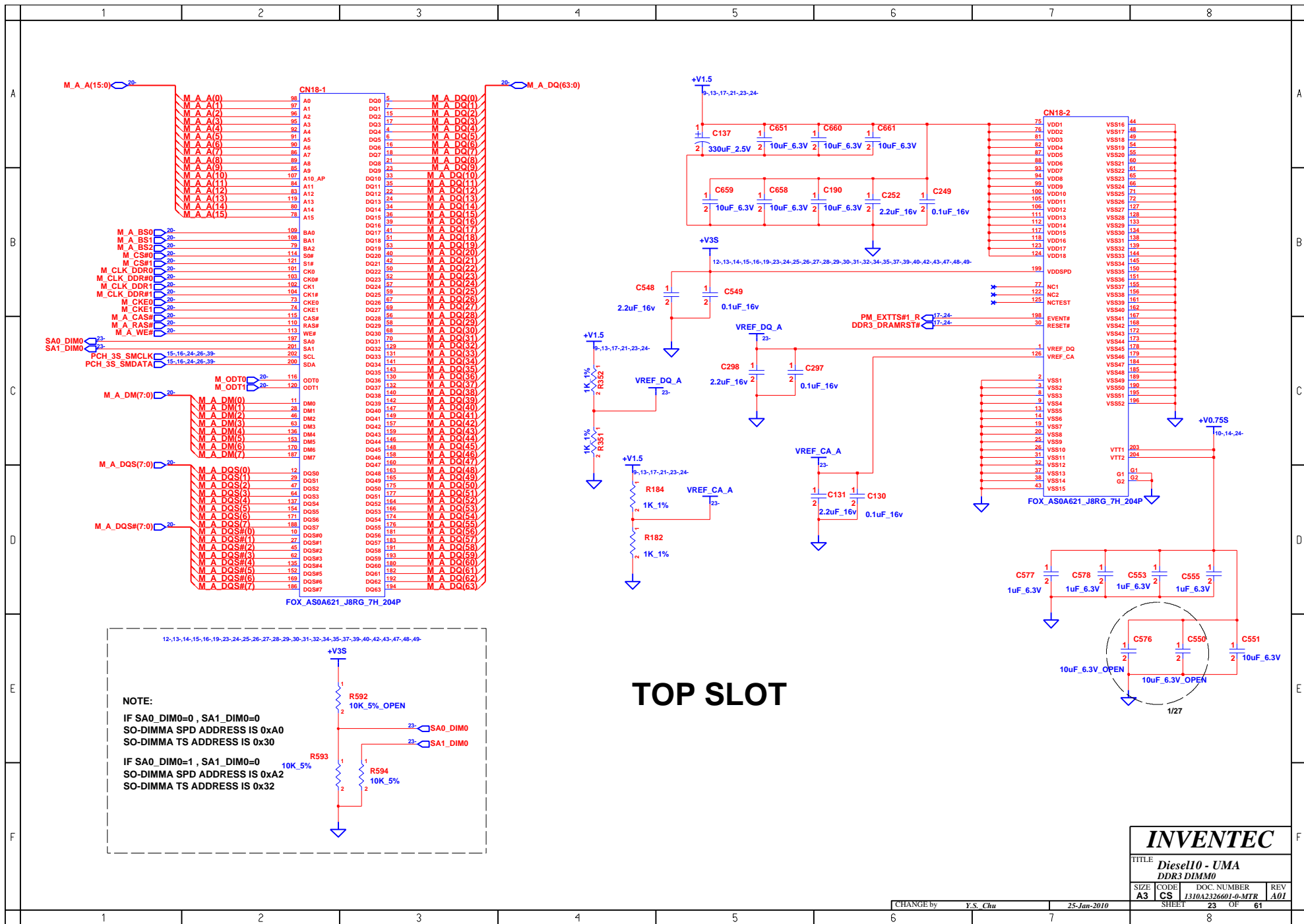

NOTE:

IF SA0_DIM0=0, SA1_DIM0=0
 SO-DIMMA SPD ADDRESS IS 0xA0
 SO-DIMMA TS ADDRESS IS 0x30

IF SA0_DIM0=1, SA1_DIM0=0
 SO-DIMMA SPD ADDRESS IS 0xA2
 SO-DIMMA TS ADDRESS IS 0x32

TOP SLOT

INVENTEC			
TITLE Diesel10 - UMA DDR3 DIMM0			
SIZE A3	CODE CS	DOC. NUMBER 1310A2326601-0-MTR	REV A01
CHANGE by Y.S. Chu		25-Jan-2010	
SHEET 23		OF 61	

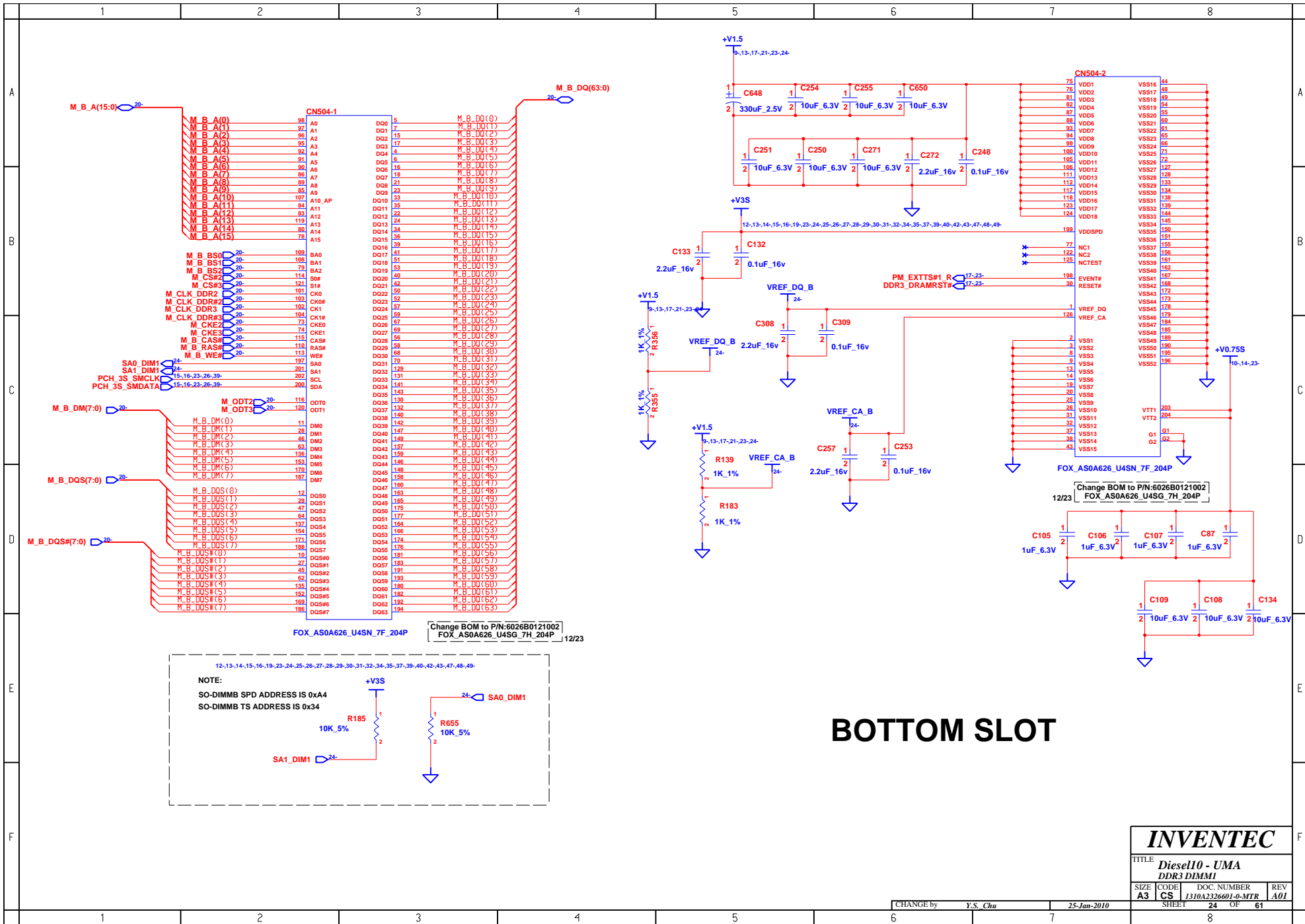

BOTTOM SLOT

INVENTEC			
TITLE Diesel10 - UMA DDR3 DIMM1			
SIZE A3	CODE CS	DOC. NUMBER 1310A2326601-0-MTR	REV A01
CHANGE by Y.S. Chu		25-Jan-2010	
SHEET 24		OF 61	

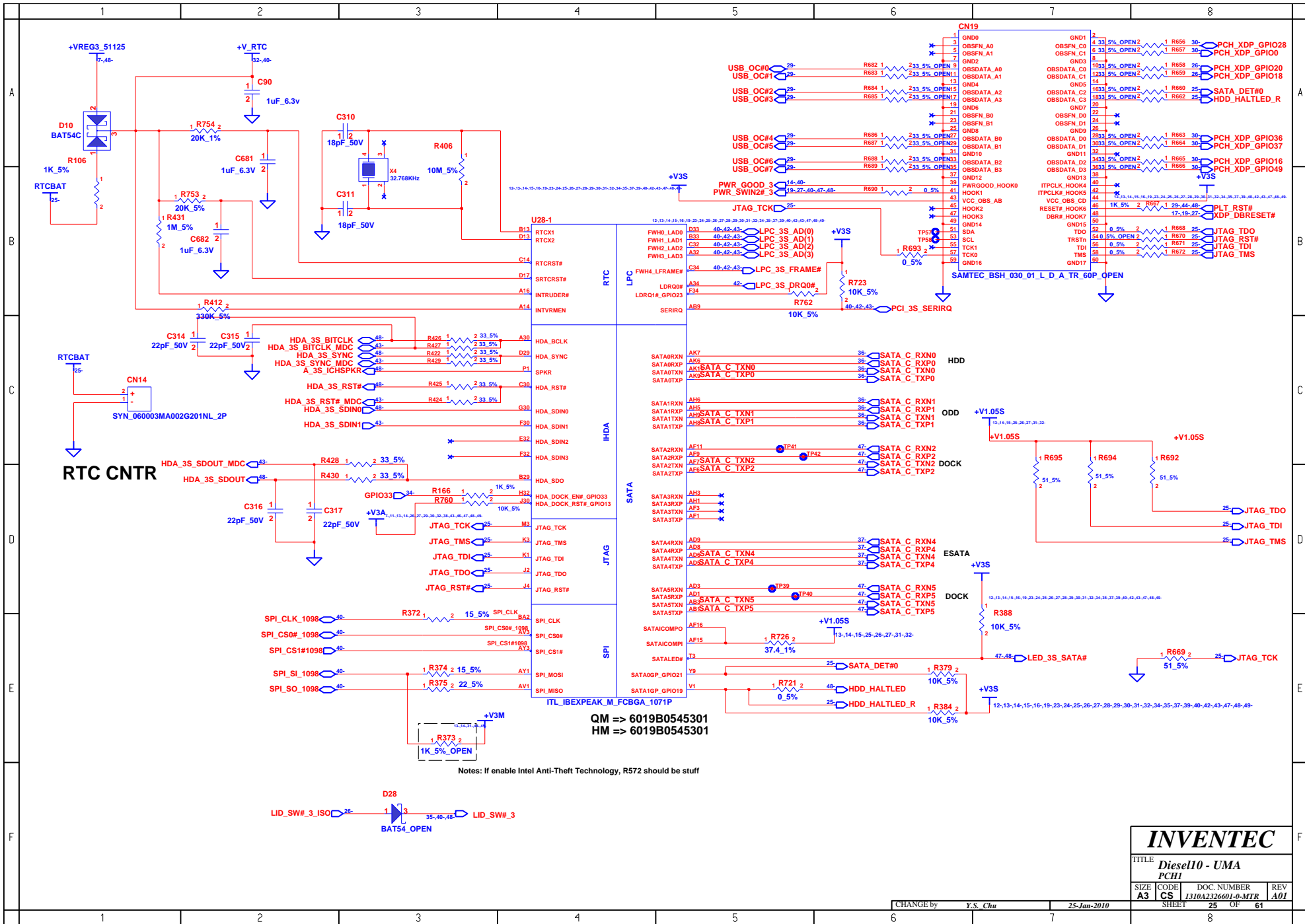

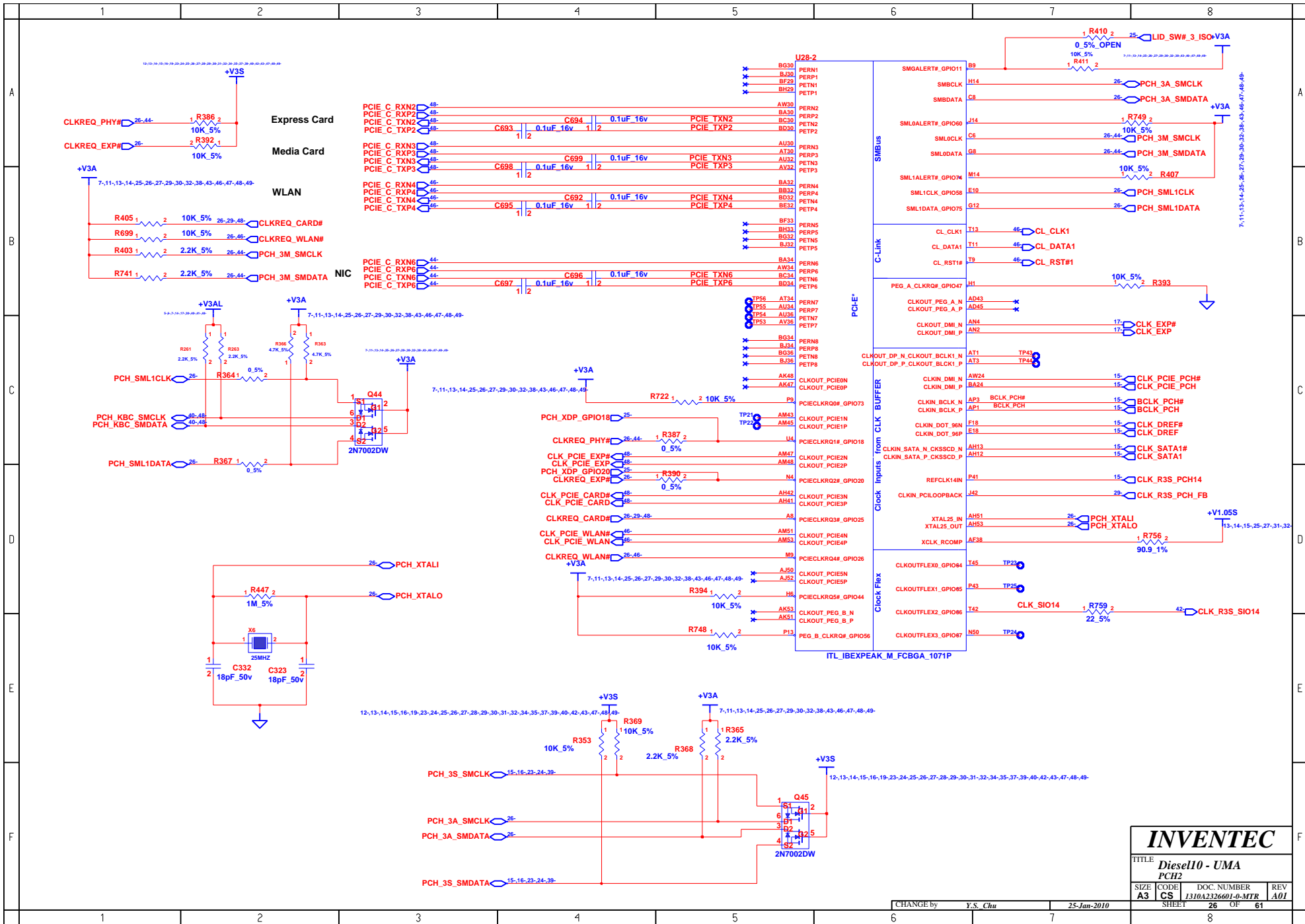

INVENTEC			
TITLE Diesel10 - UMA PCH2			
SIZE A3	CODE CS	DOC. NUMBER 1310A2326001-0-MTR	REV A01
CHANGE by Y.S. Chu		25-Jan-2010	
SHEET 26		OF 61	

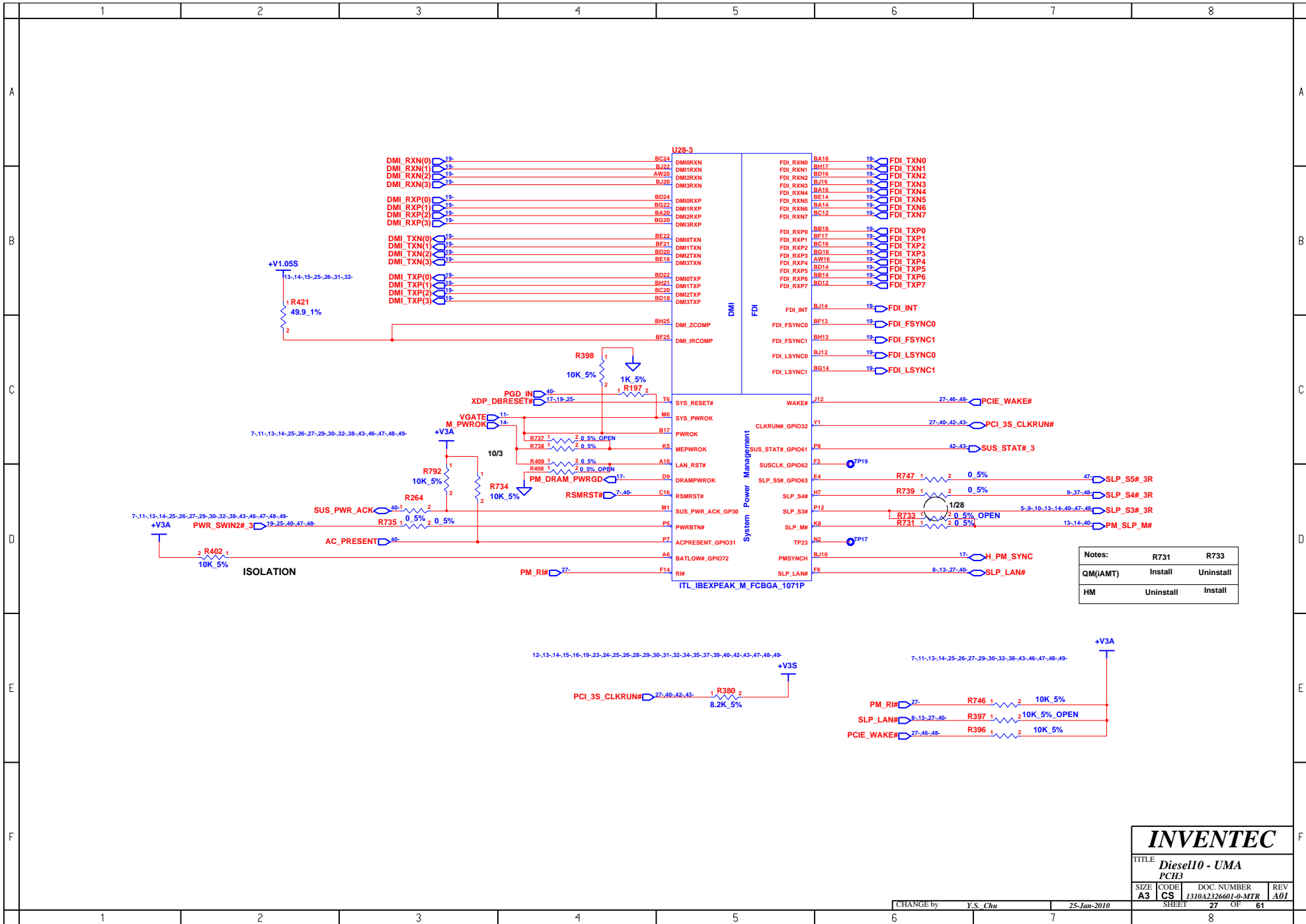

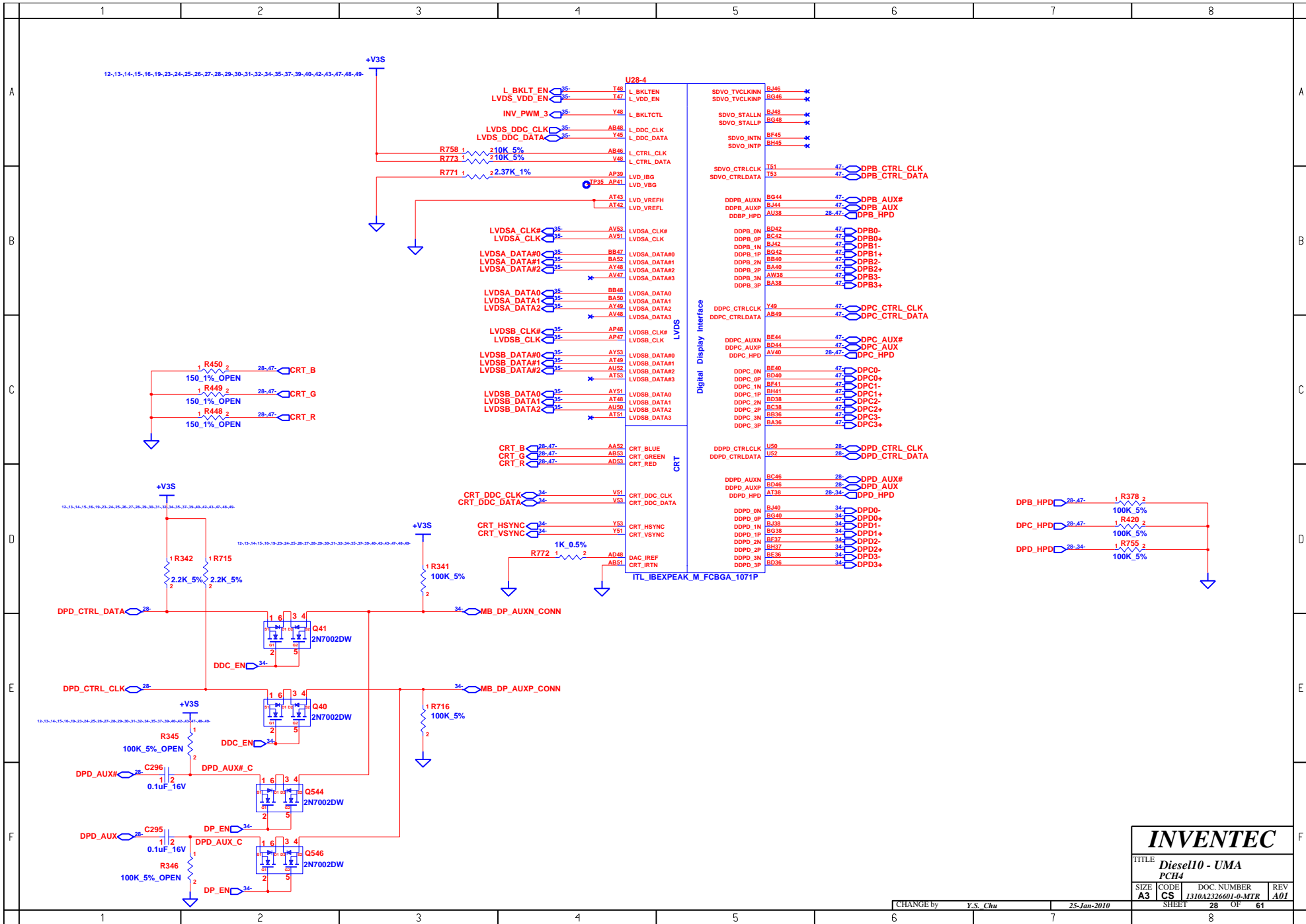

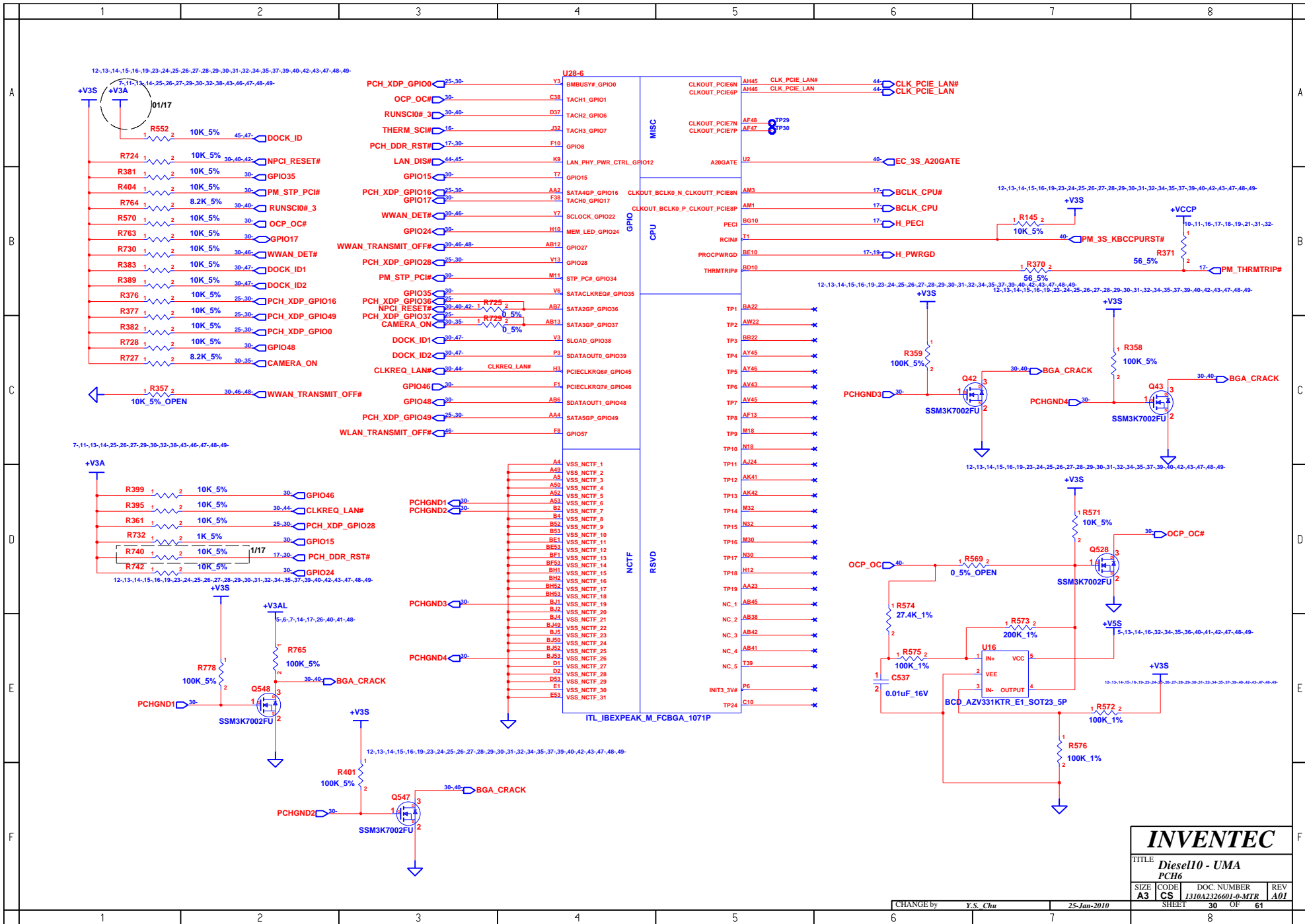

INVENTEC

TITLE: Diesel10 - UMA
PCH6

SIZE	CODE	DOC. NUMBER	REV
A3	CS	1310A232601-0-MTR	A01

CHANGE by Y.S. Chu 25-Jan-2010

SHEET 30 OF 61

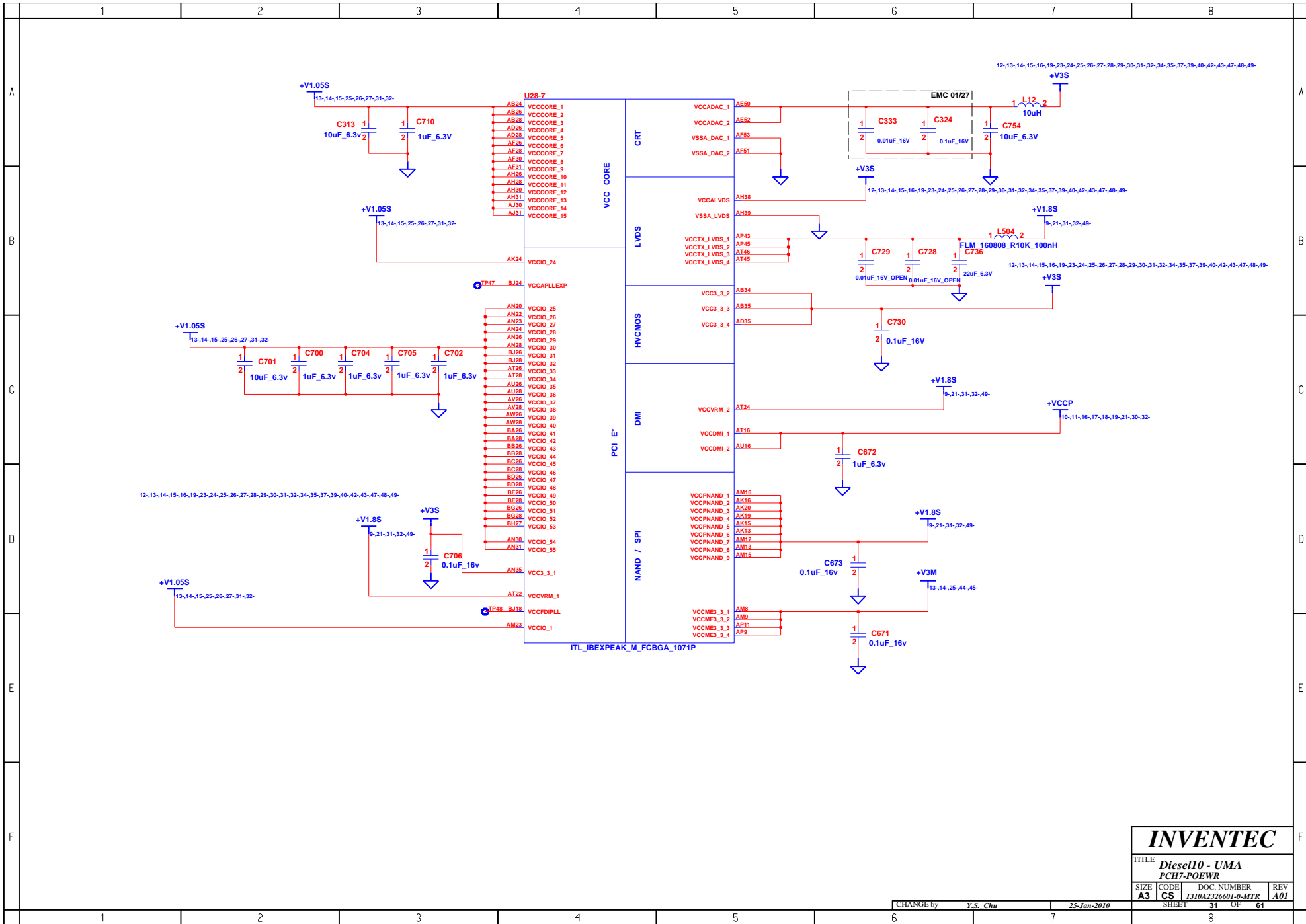

INVENTEC			
TITLE Diesel10 - UMA PCH7-POEWR			
SIZE A3	CODE CS	DOC. NUMBER 1310A2326601-0-MTR	REV A01
CHANGE by Y.S. Chu		25-Jan-2010	
SHEET 31		OF 61	

<http://sualaptop365.edu.vn>

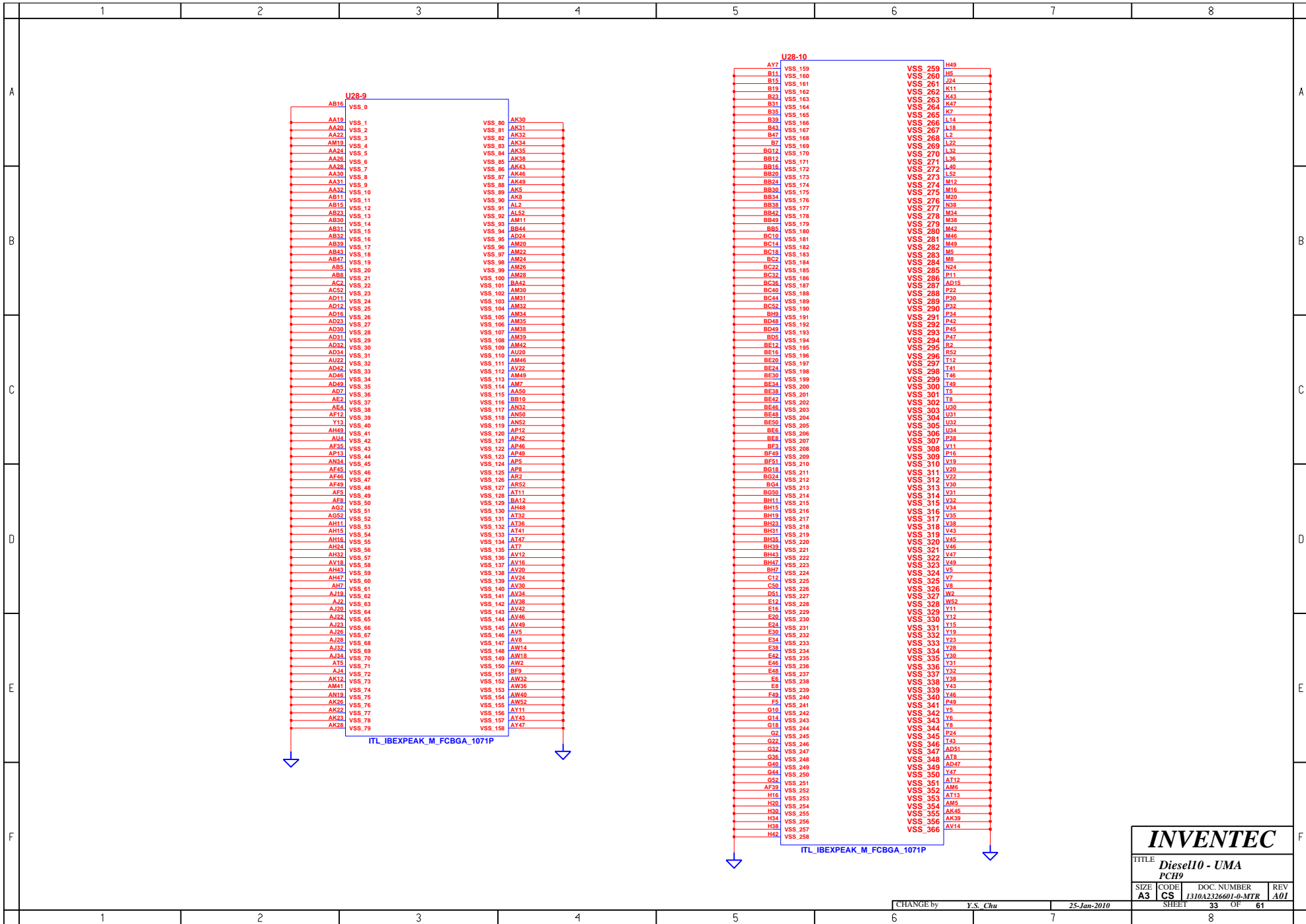

INVENTEC

TITLE: Diesel10 - UMA
PCH9

SIZE A3	CODE CS	DOC. NUMBER 1310A232601-0-MTR	REV A01
SHEET		33	OF 61

<http://sualaptop365.edu.vn>

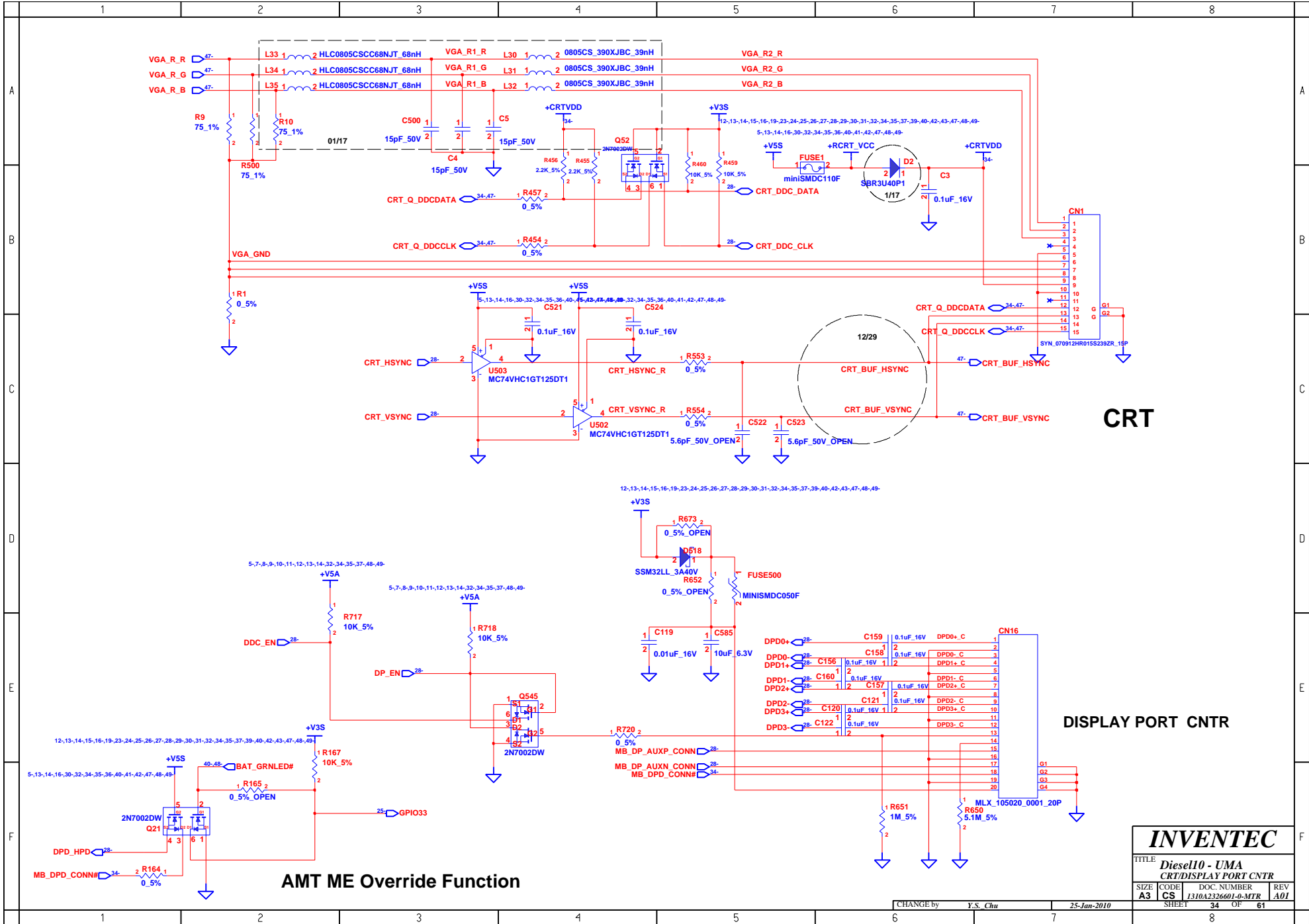

INVENTEC			
TITLE Diesel10 - UMA CRT/DISPLAY PORT CNTR			
SIZE A3	CODE CS	DOC NUMBER 1310A232601-0-MTR	REV A01
SHEET		34 OF 61	

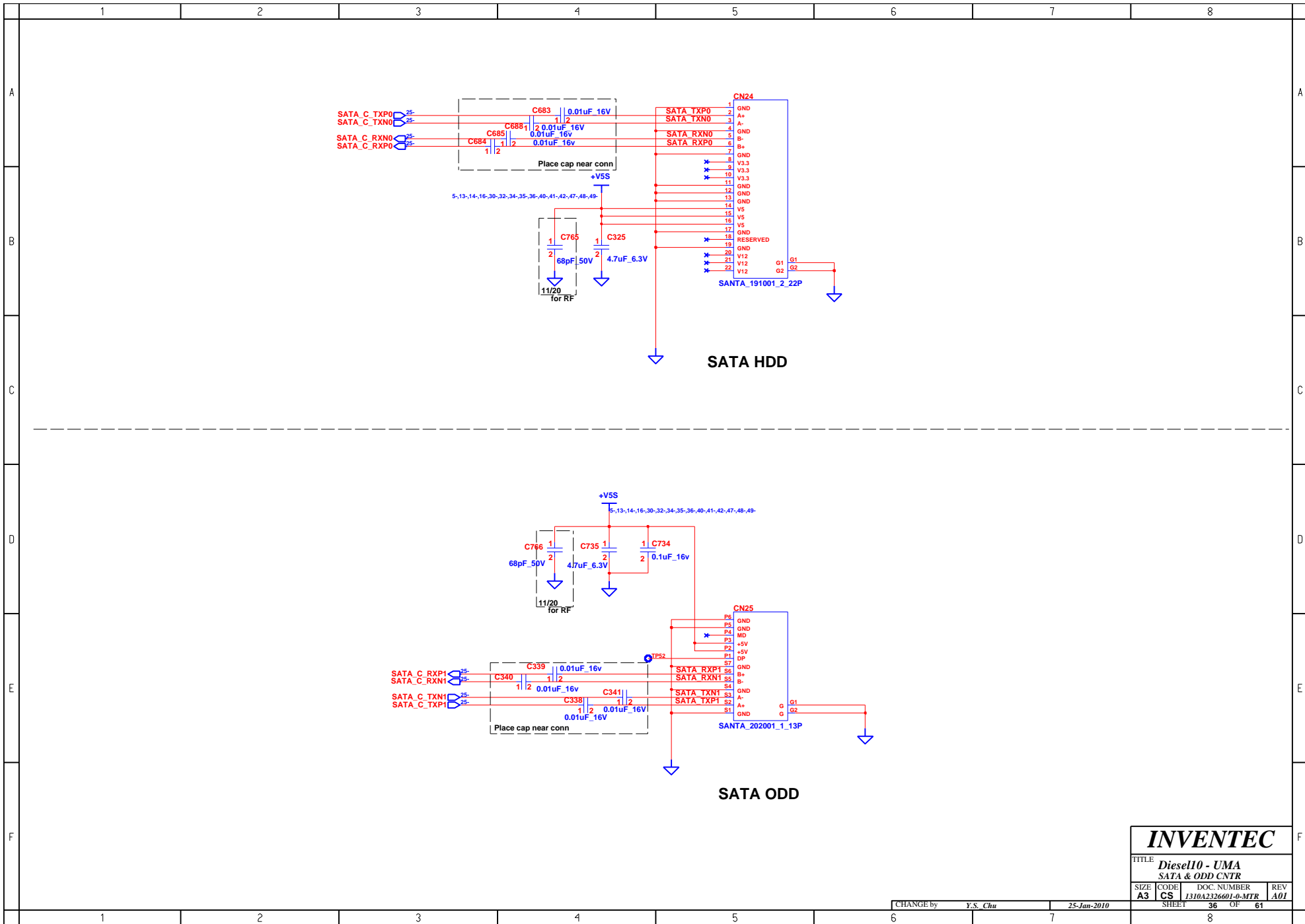

INVENTEC

TITLE Diesel10 - UMA
SATA & ODD CNTR

SIZE	CODE	DOC. NUMBER	REV
A3	CS	1310A2326601-0-MTR	A01

CHANGE by Y.S. Chu 25-Jan-2010

SHEET 36 OF 61

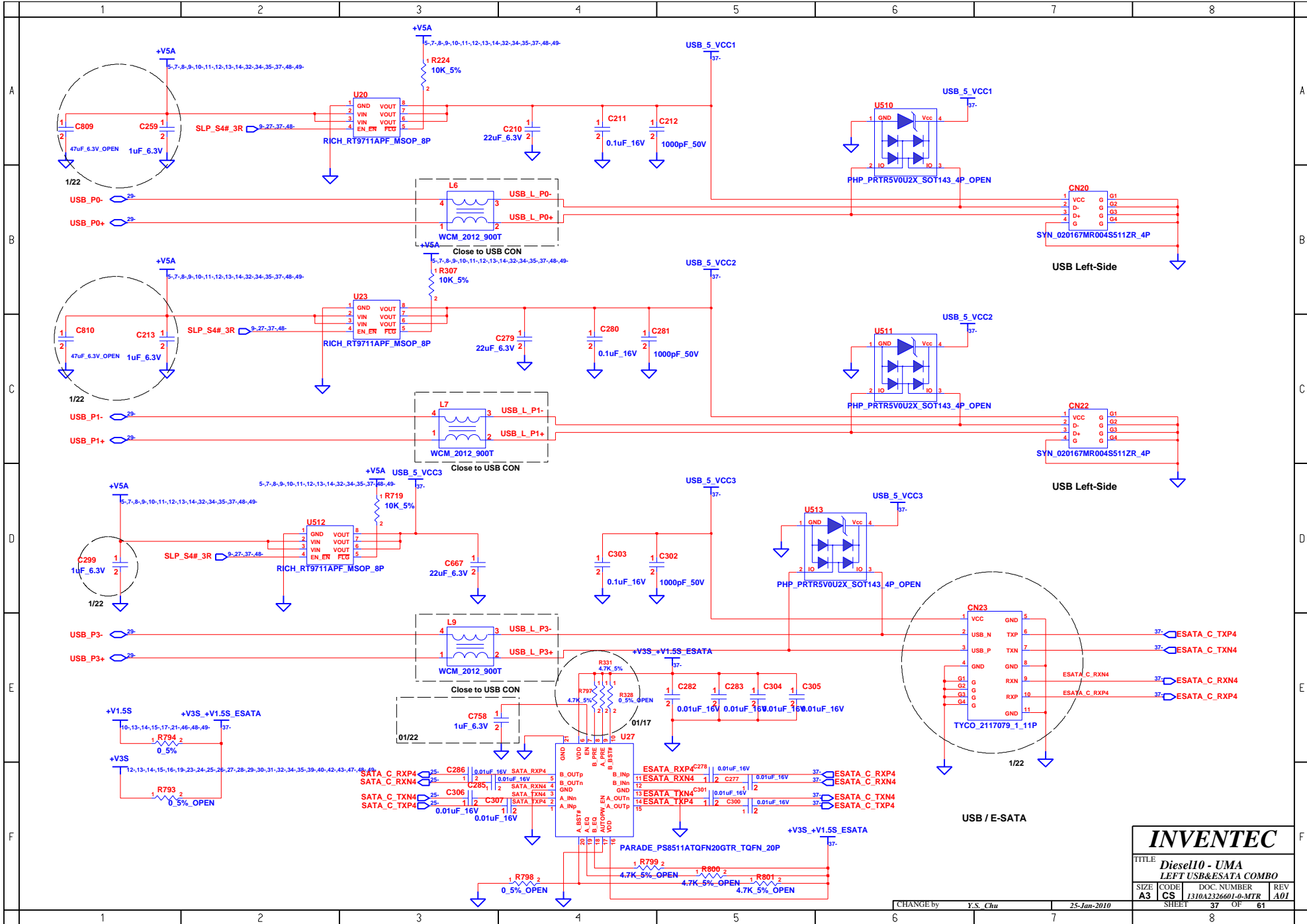

INVENTEC			
TITLE Diesel10 - UMA LEFT USB&ESATA COMBO			
SIZE A3	CODE CS	DOC NUMBER 1310A2326001-0-MTR	REV A01
SHEET 37		OF 61	

CHANGE by Y.S. Chu 25-Jan-2010

<http://sualaptop365.edu.vn>

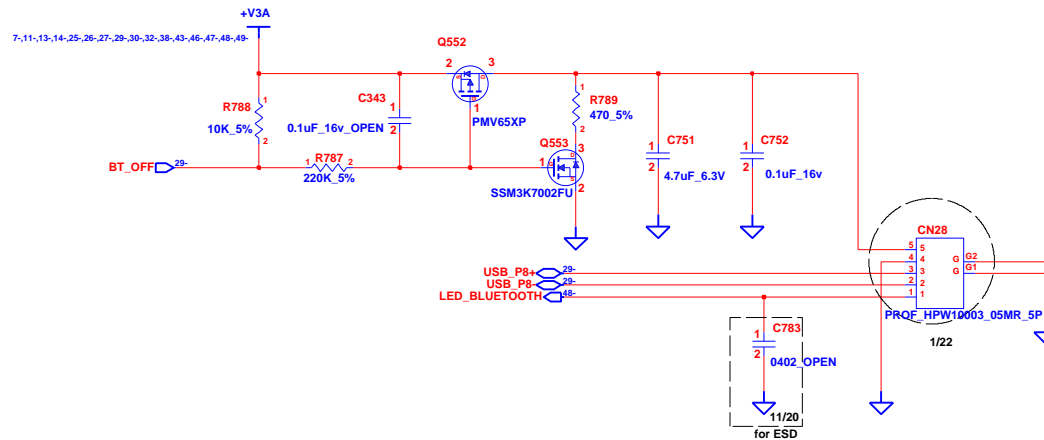

BLUETOOTH

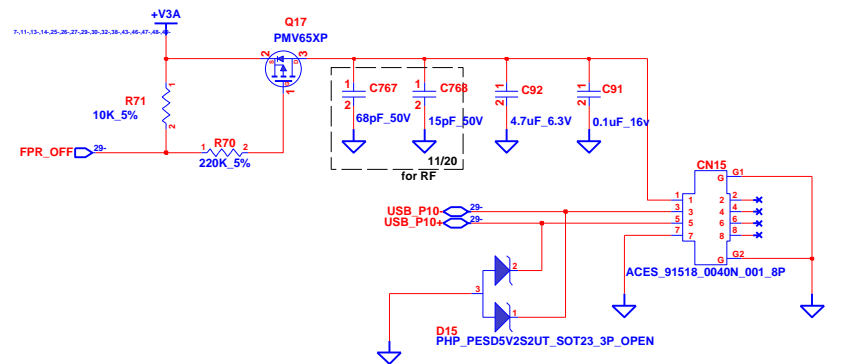

FINGER PRINTER CNTR

INVENTEC			
TITLE Diesel10 - UMA			
BLUETOOTH&FINGER PRINTER			
SIZE A3	CODE CS	DOC. NUMBER 1310A2326601-0-MTR	REV A01
CHANGE by Y.S. Chu		25-Jan-2010	SHEET 38 OF 61

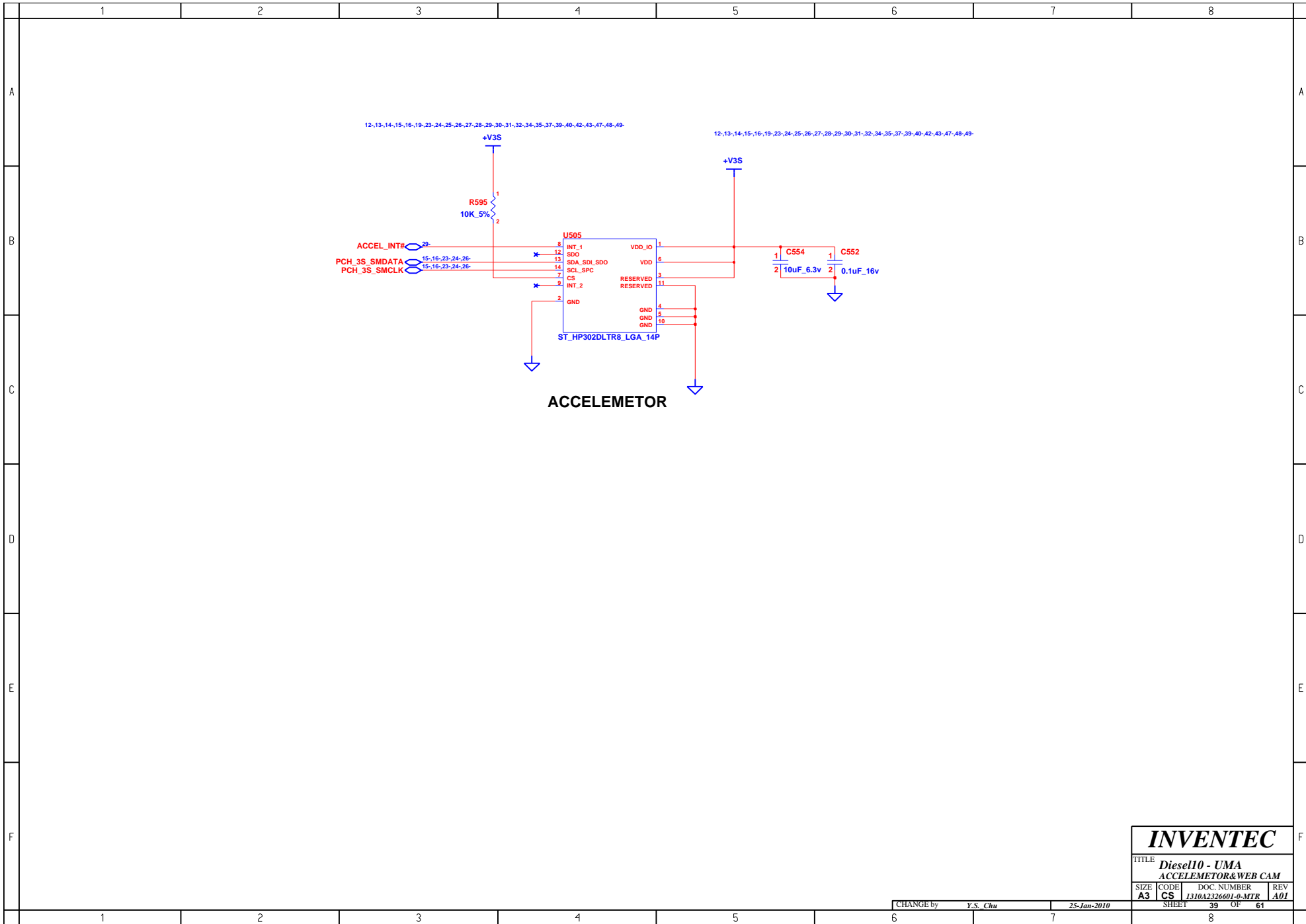

INVENTEC

TITLE **Diesel10 - UMA
ACCELEMETOR&WEB CAM**

SIZE A3	CODE CS	DOC. NUMBER 1310A2326601-0-MTR	REV A01
-------------------	-------------------	--	-------------------

CHANGE by **Y.S. Chu** 25-Jan-2010

SHEET **39** OF **61**

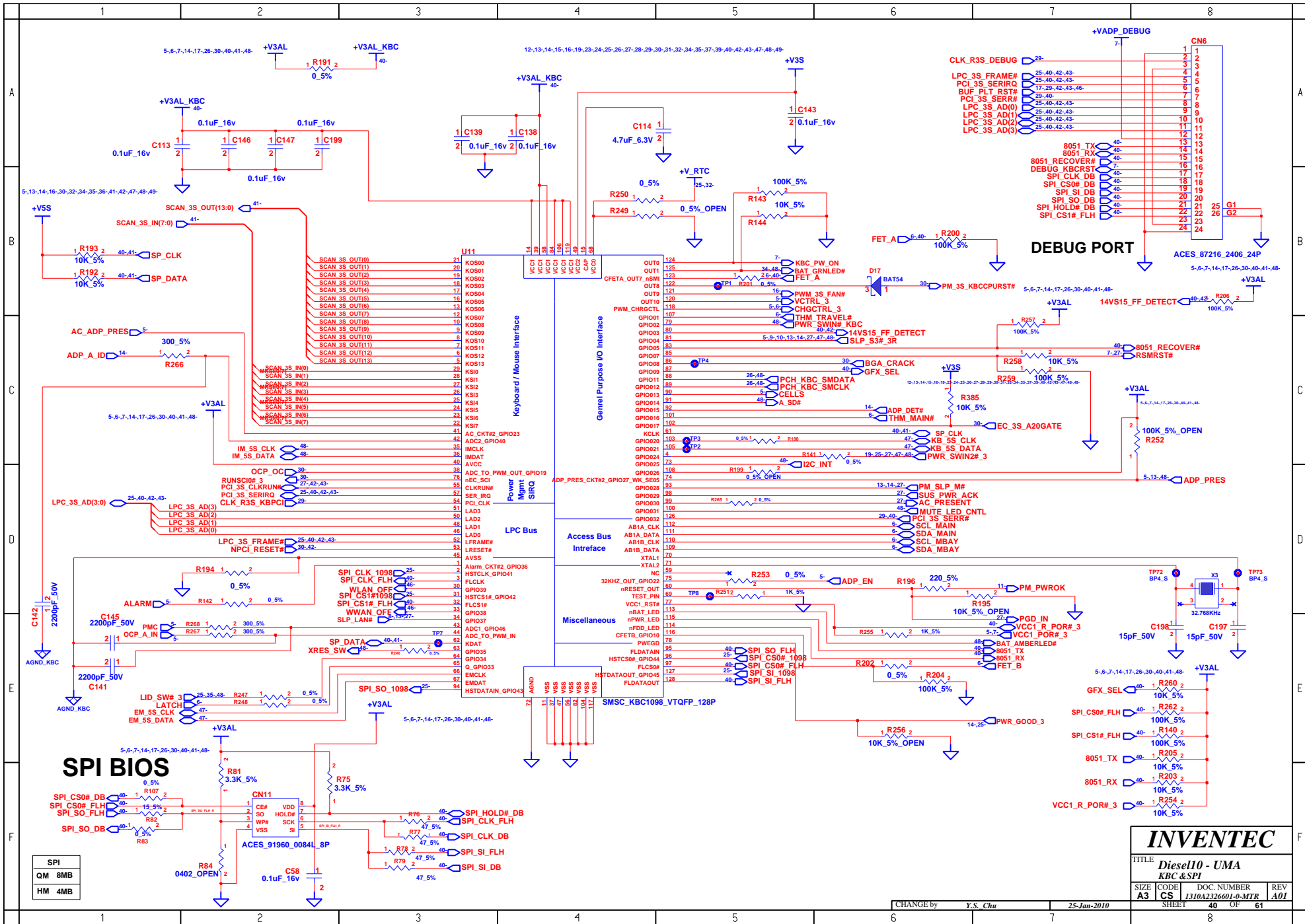

SPI	
QM	8MB
HM	4MB

INVENTEC			
TITLE Diesel10-UMA KBC & SPI			
SIZE	CODE	DOC. NUMBER	REV
A3	CS	1310A2326601-0-MTR	A01
SHEET	40	OF	61

CHANGE by Y.S. Chu 25-Jan-2010

<http://sualaptop365.edu.vn>

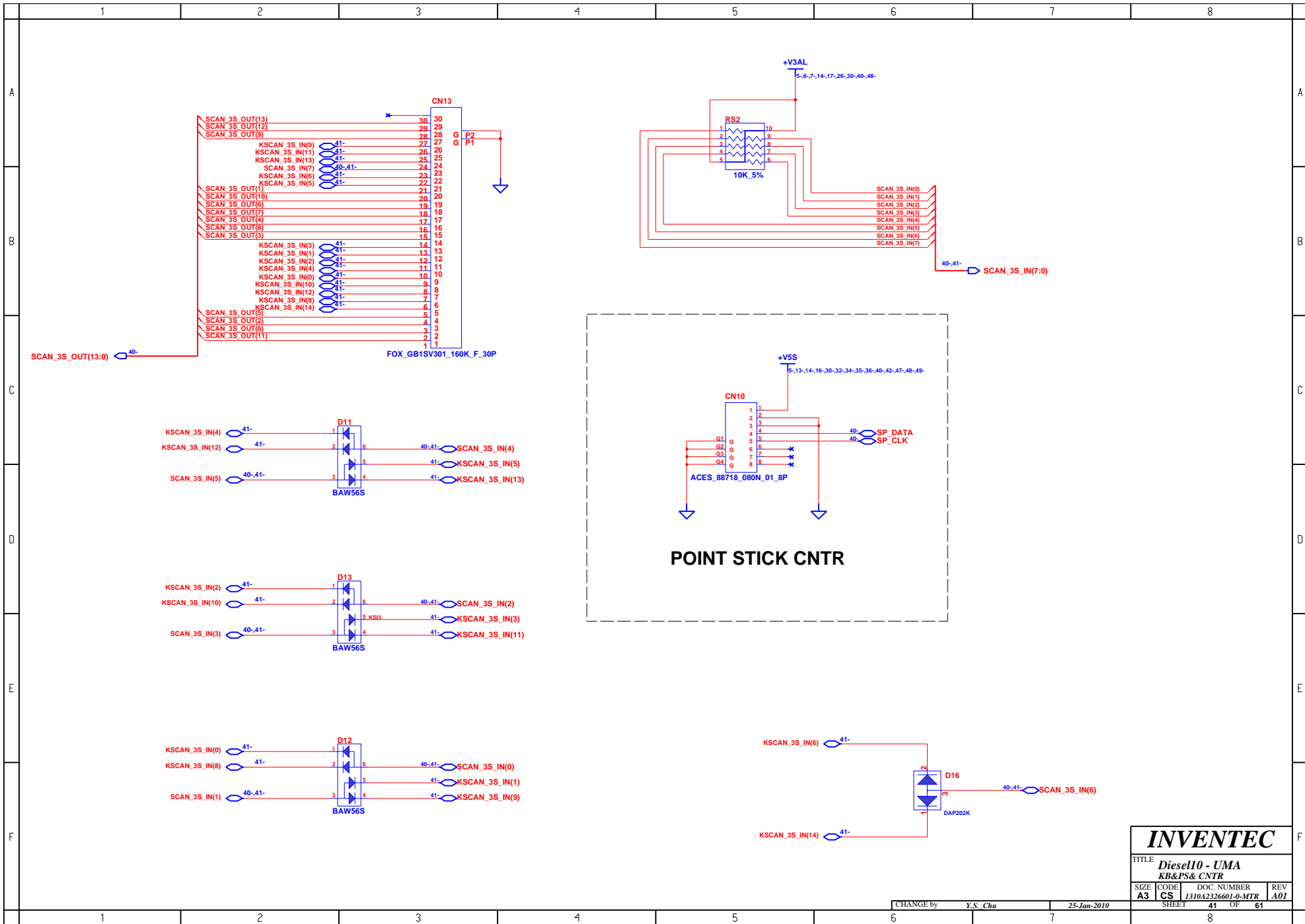

INVENTEC			
TITLE Diesel10 - UMA KB&PS& CNTR			
SIZE A3	CODE CS	DOC NUMBER 1310A2326601-0-MTR	REV A01
CHANGE by Y.S. Chu		25-Jan-2010	
SHEET 41		OF 61	

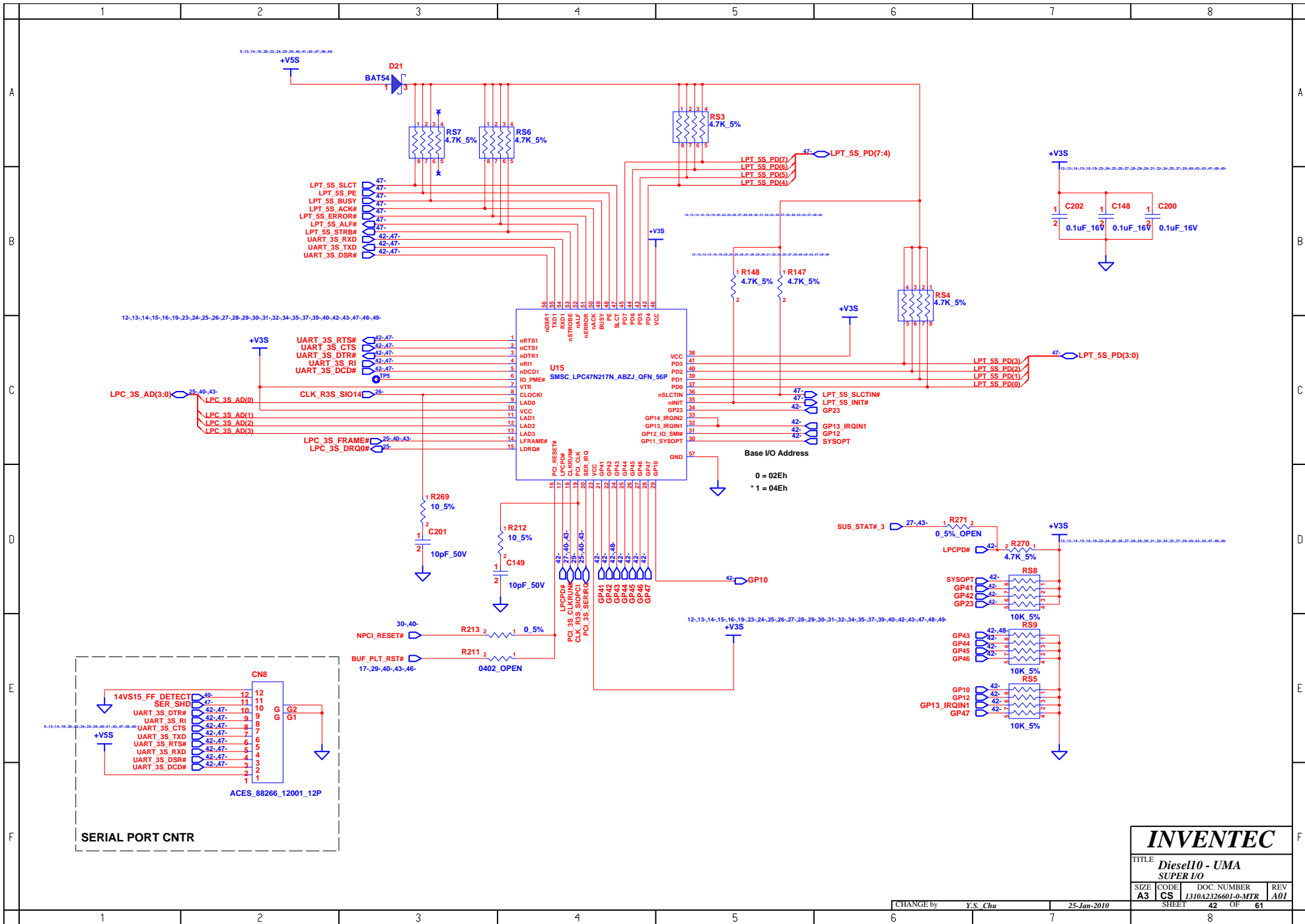

INVENTEC			
TITLE Diesel10 - UMA SUPER I/O			
SIZE A3	CODE CS	DOC. NUMBER 1310A232601-0-MTR	REV A01
CHANGE by Y.S. Chu		25-Jan-2010	
SHEET 42		OF 61	

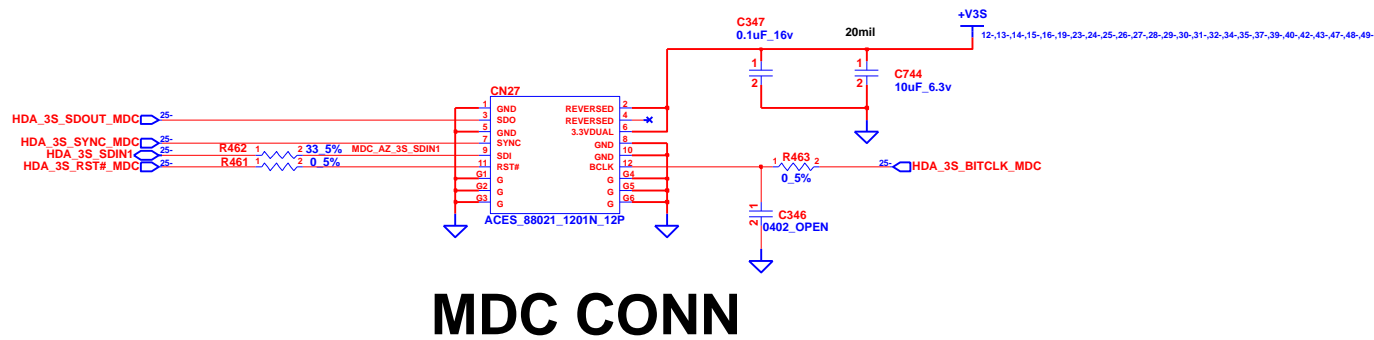
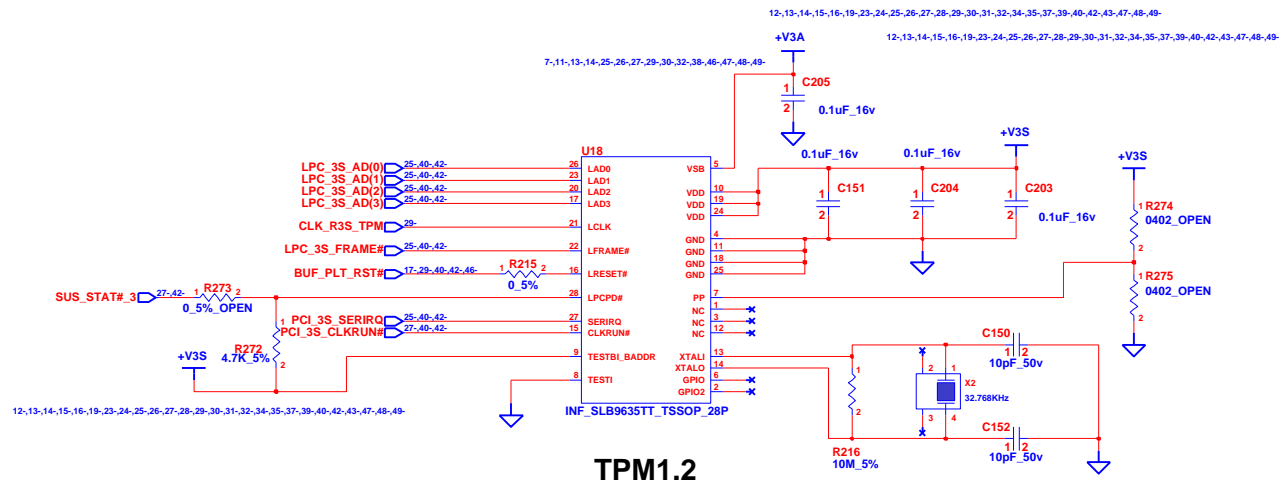

INVENTEC			
TITLE <i>Diesel10 - UMA</i> <i>TPM & MDC</i>			
SIZE A3	CODE CS	DOC. NUMBER <i>1310A2326601-p-MTR</i>	REV A01
CHANGE by <i>Y.S. Chu</i>		25-Jan-2010	
SHEET 43		OF 61	

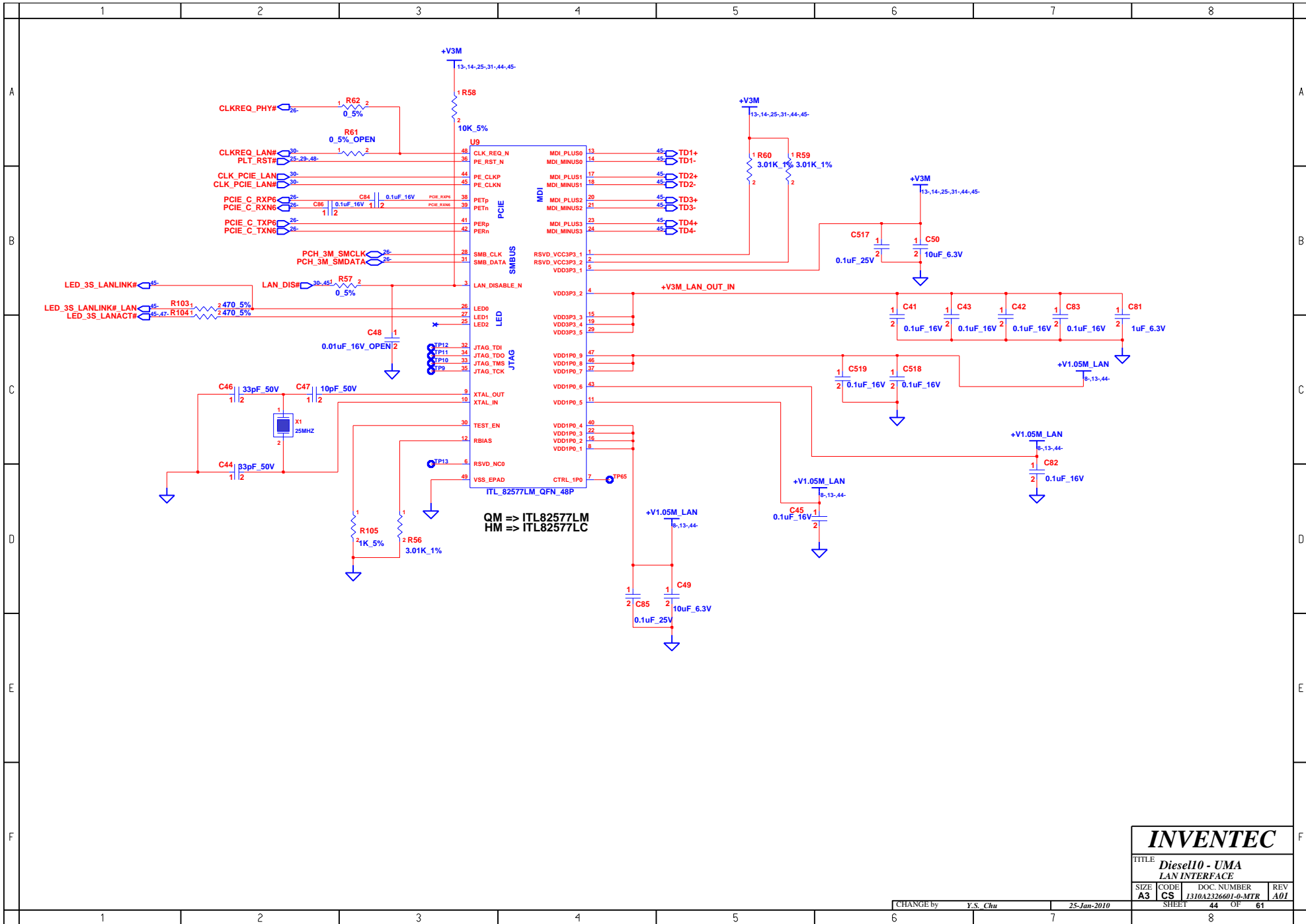

INVENTEC			
TITLE Diesel10 - UMA LAN INTERFACE			
SIZE A3	CODE CS	DOC. NUMBER 1310A2326601-0-MTR	REV A01
CHANGE by Y.S. Chu		25-Jan-2010	
SHEET 44		OF 61	

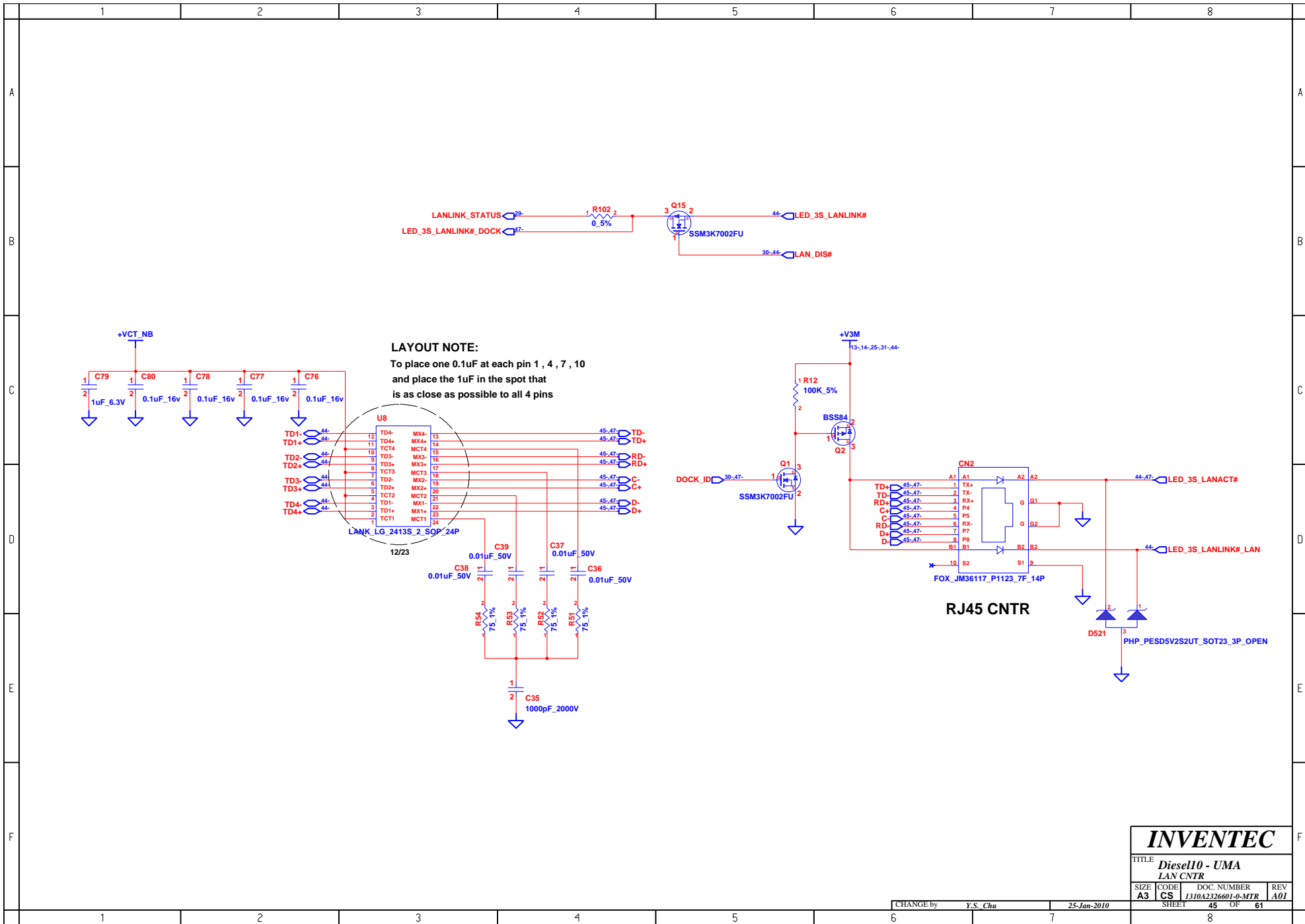

INVENTEC			
TITLE Diesel10 - UMA LAN CNTR			
SIZE A3	CODE CS	DOC. NUMBER 1310A2326601-0-MTR	REV A01
CHANGE by Y.S. Chu		25-Jan-2010	
SHEET 45		OF 61	

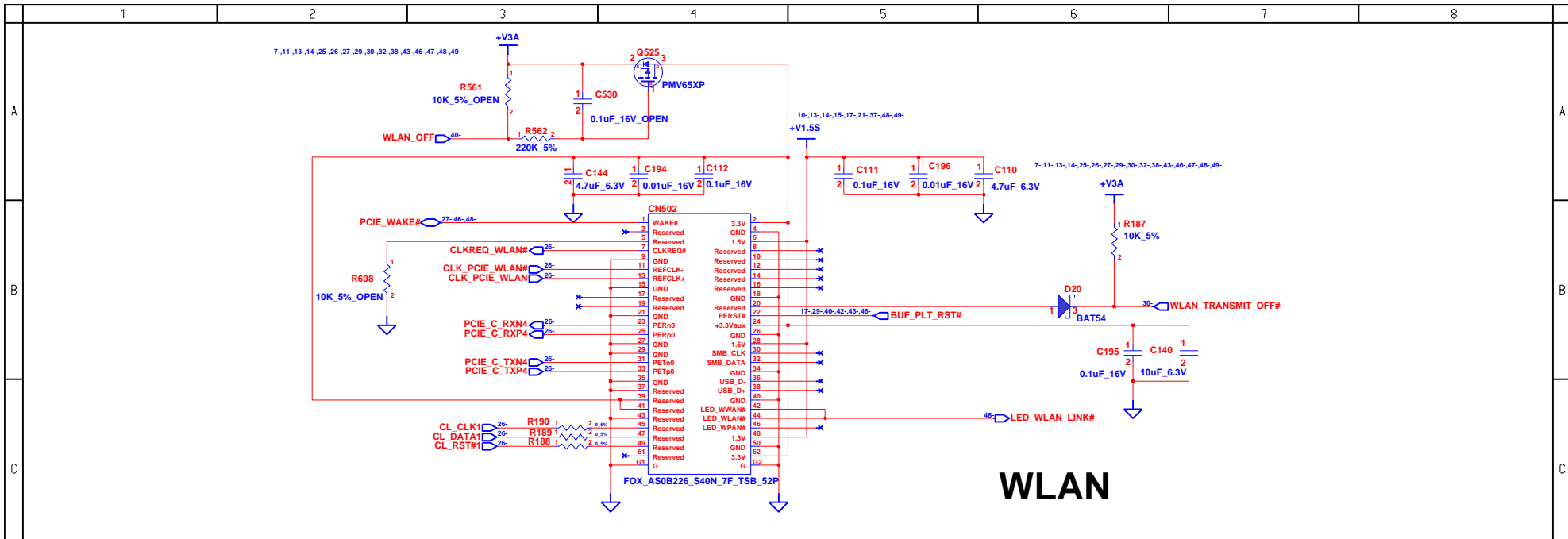

WLAN

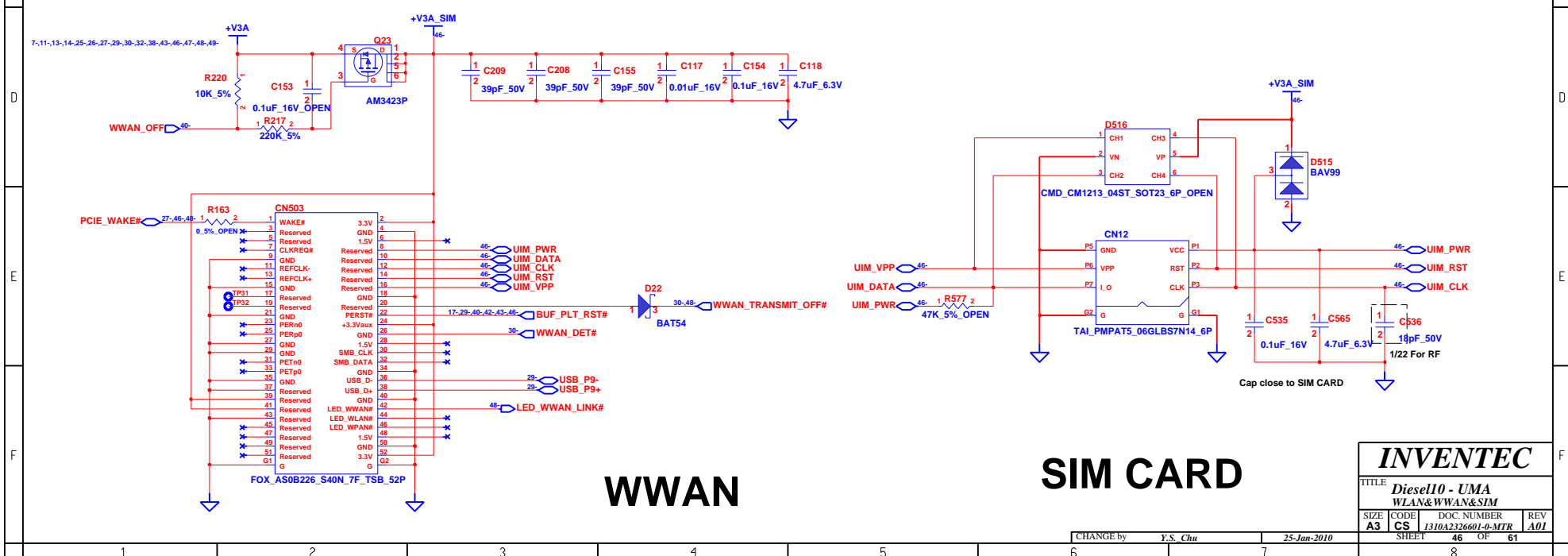

WWAN

SIM CARD

INVENTEC			
TITLE Diesel10 - UMA WLAN&WWAN&SIM			
SIZE A3	CODE CS	DOC. NUMBER 1310A232601-0-MTR	REV A01
CHANGE by Y.S. Chu		25-Jan-2010	
SHEET 46		OF 61	

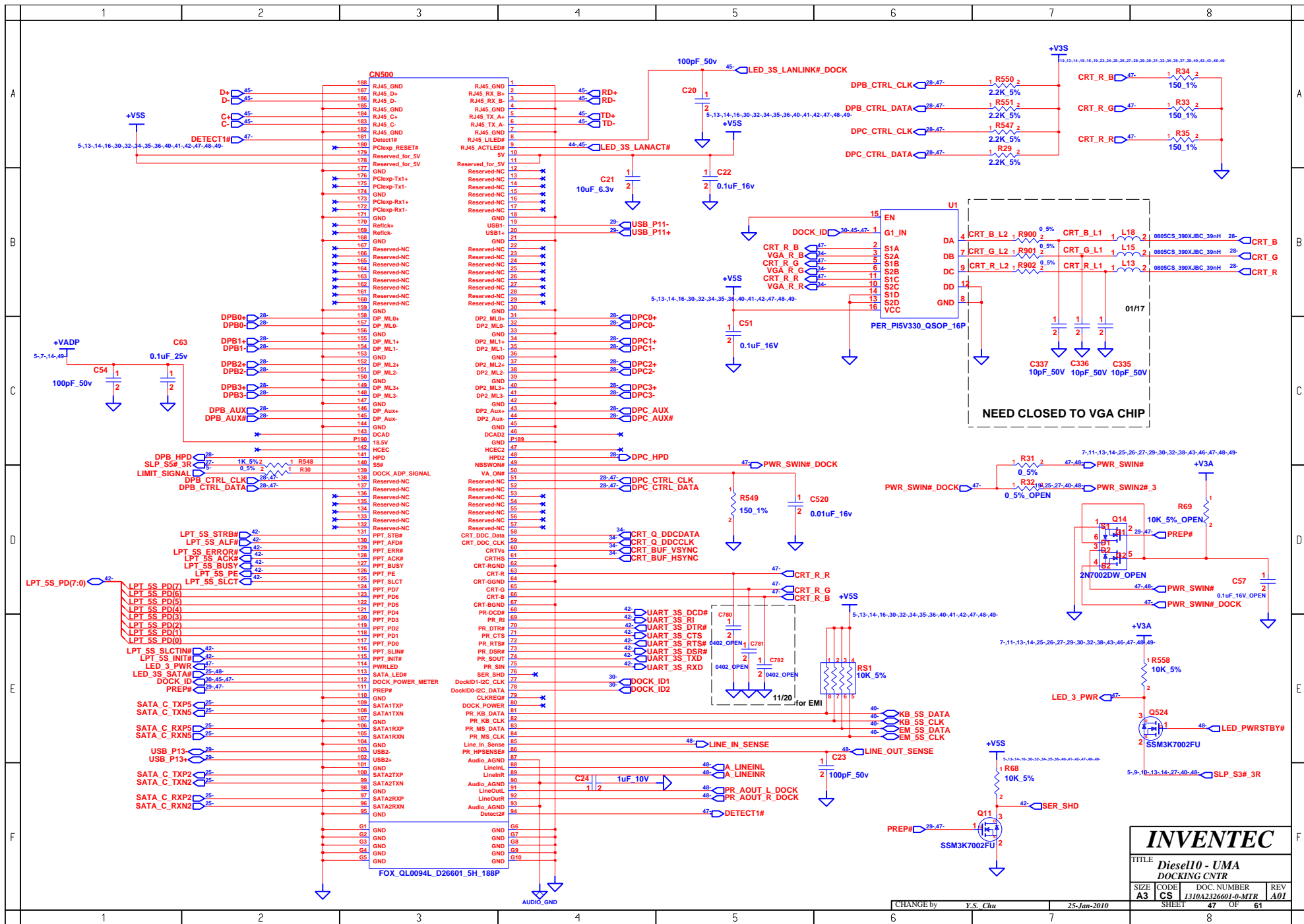

INVENTEC			
TITLE Diesel10 - UMA DOCKING CNTR			
SIZE A3	CODE CS	DOC. NUMBER 1310A2326601-0-MTR	REV A01
SHEET 47		OF 61	

CHANGE by **Y.S. Chu** 25-Jan-2010

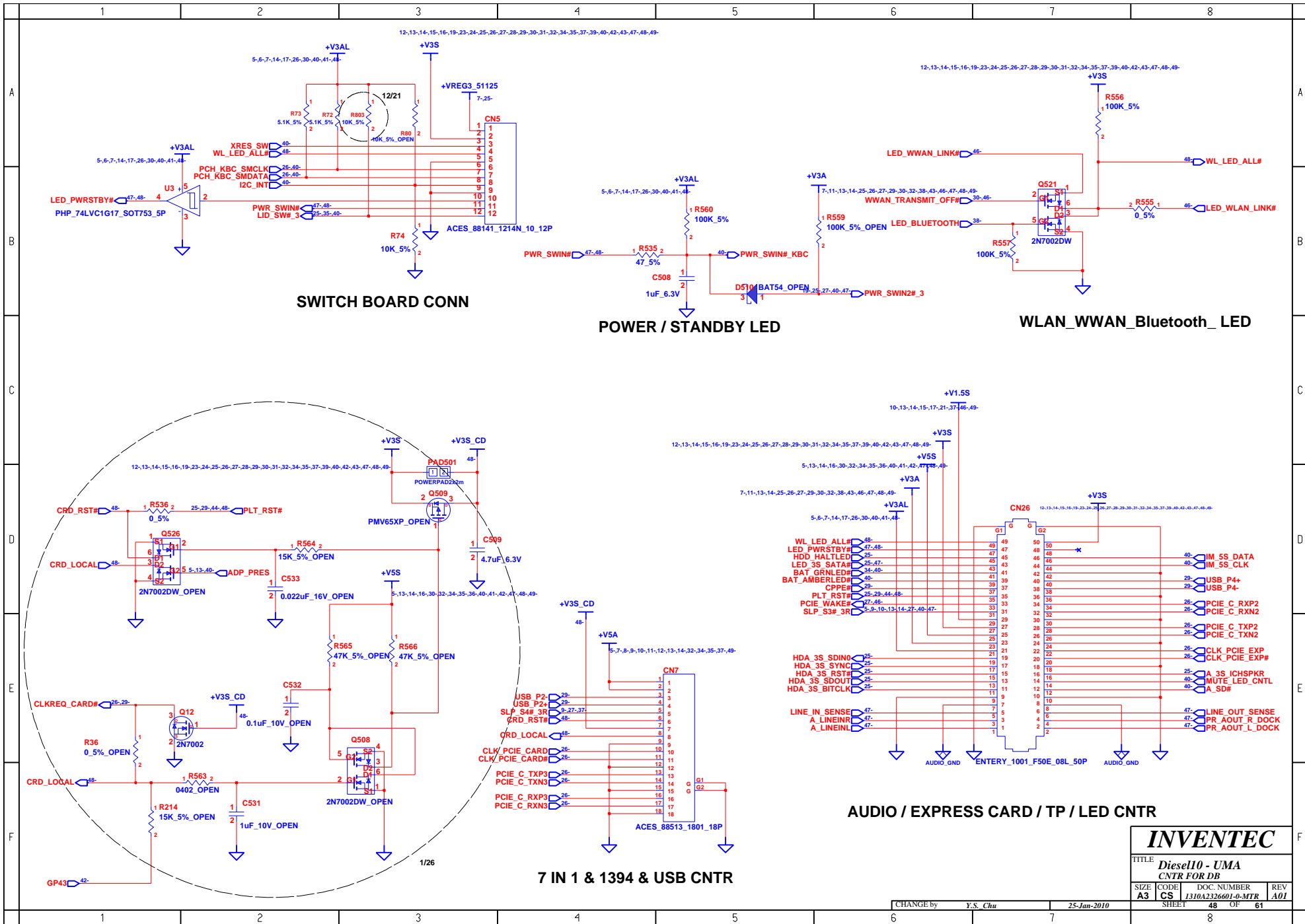

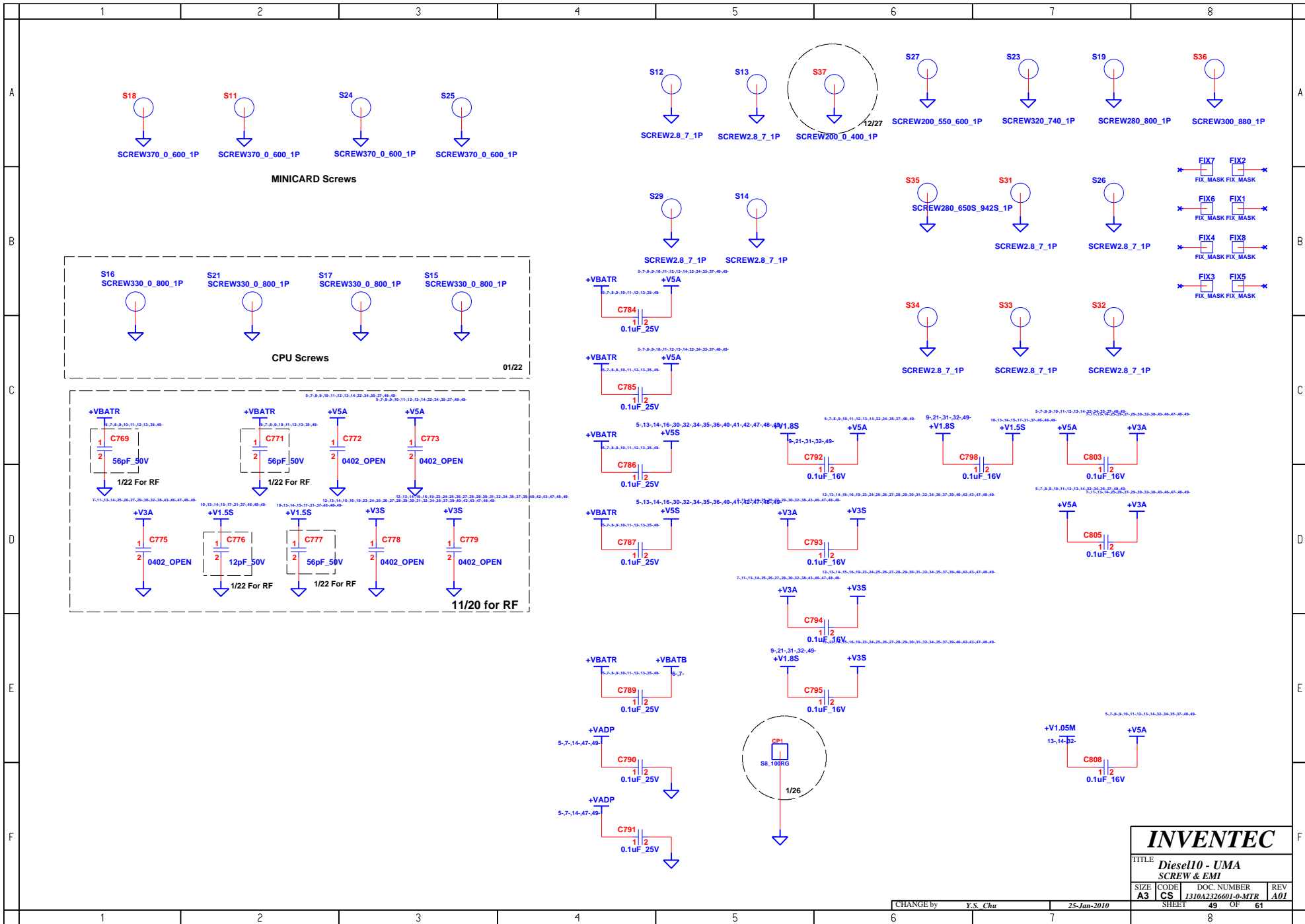

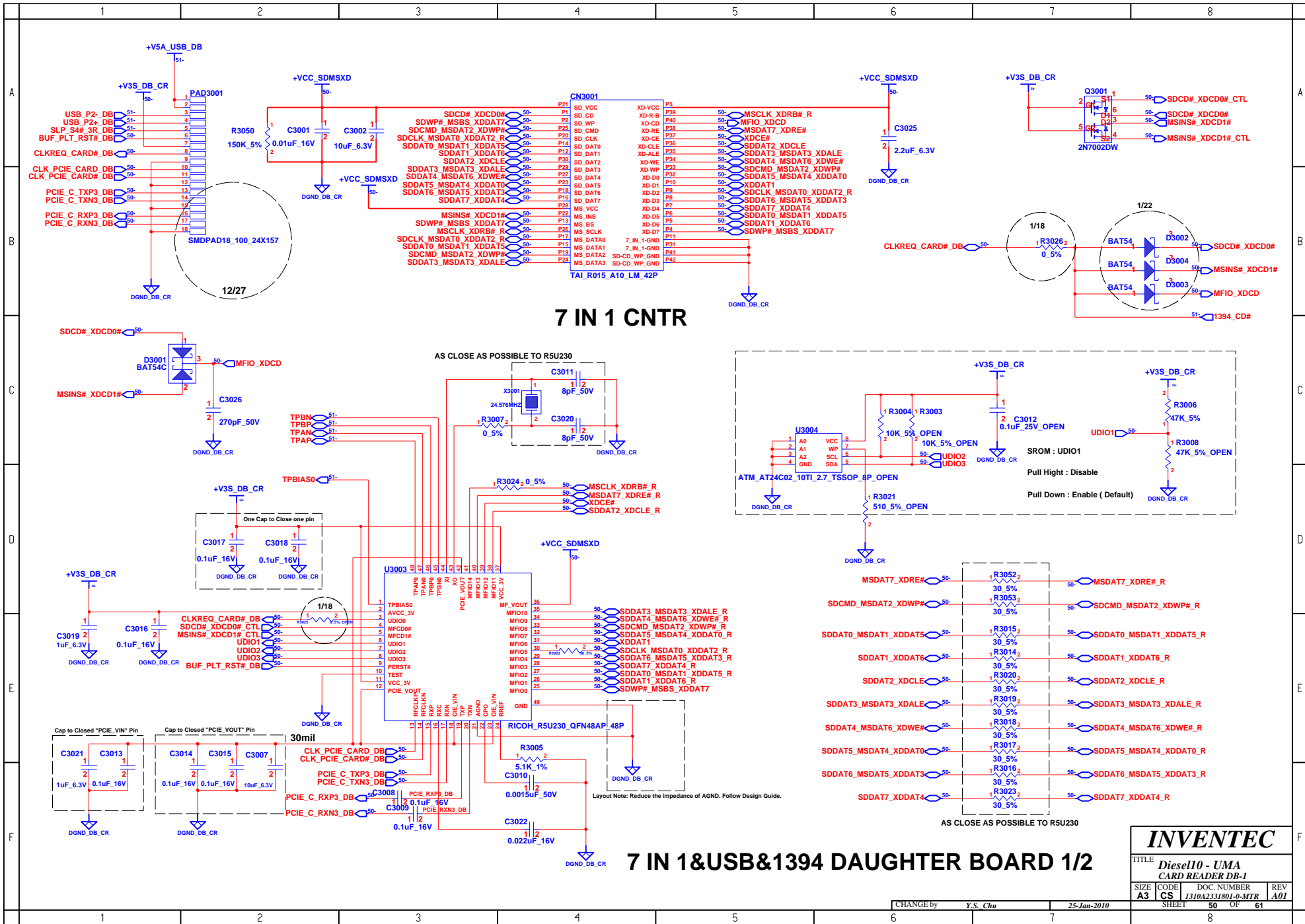

<http://sualaptop365.edu.vn>

INVENTEC			
TITLE: Diesel10 - UMA CARD READER DB-1			
SIZE: A3	CODE: CS	DOC. NUMBER: 1310A231801-0-MTR	REV: A01
SHEET: 50		OF: 61	

CHANGE by: Y.S. Chu 25-Jan-2010

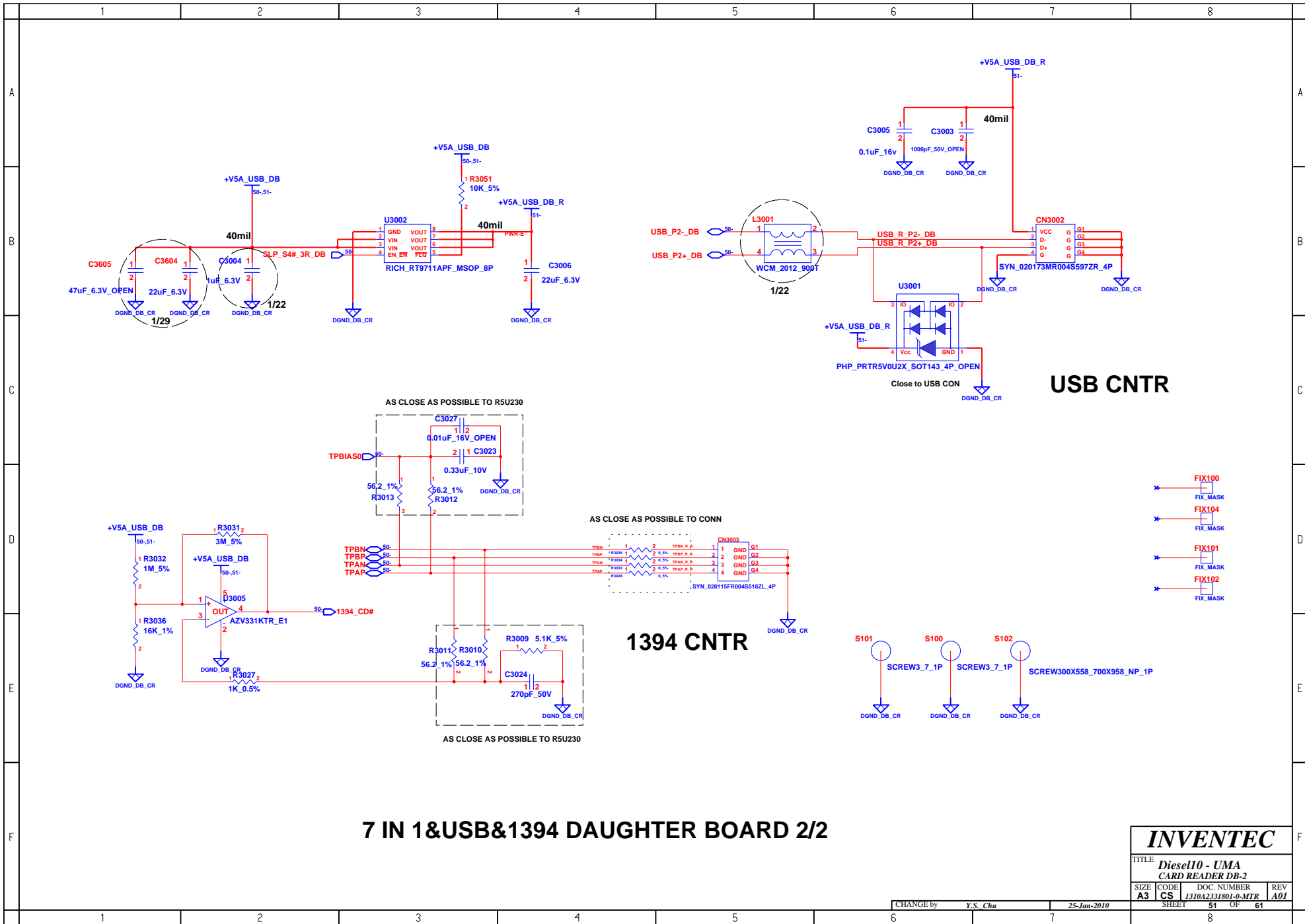

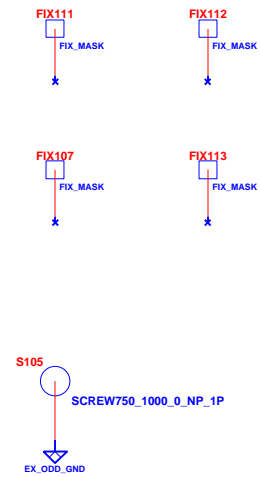
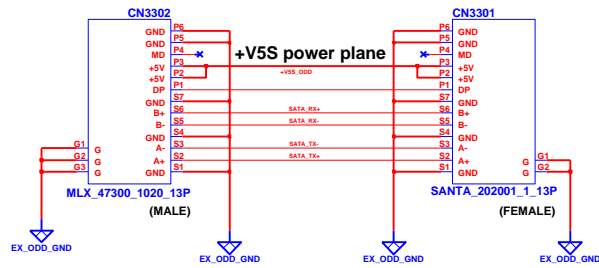

15" only

ODD Extension Board

INVENTEC			
TITLE <i>Diesel10 - UMA ODD DB</i>			
SIZE A3	CODE CS	DOC. NUMBER <i>1310A231701-p-MTR</i>	REV A01
CHANGE by <i>Y.S. Chu</i>		DATE <i>25-Jan-2010</i>	
SHEET 52		OF 61	

WIRELESS LED

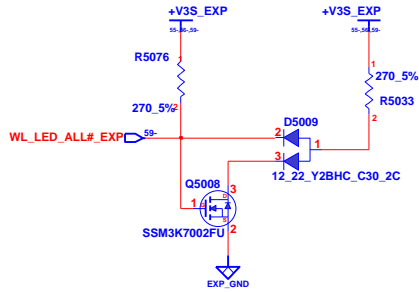

POWER LED

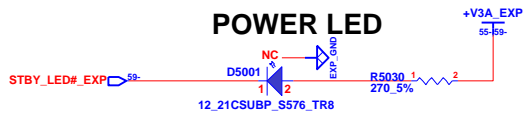

BATTERY LED

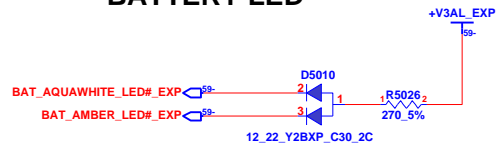

SATA LED & HDD-HALTED LED

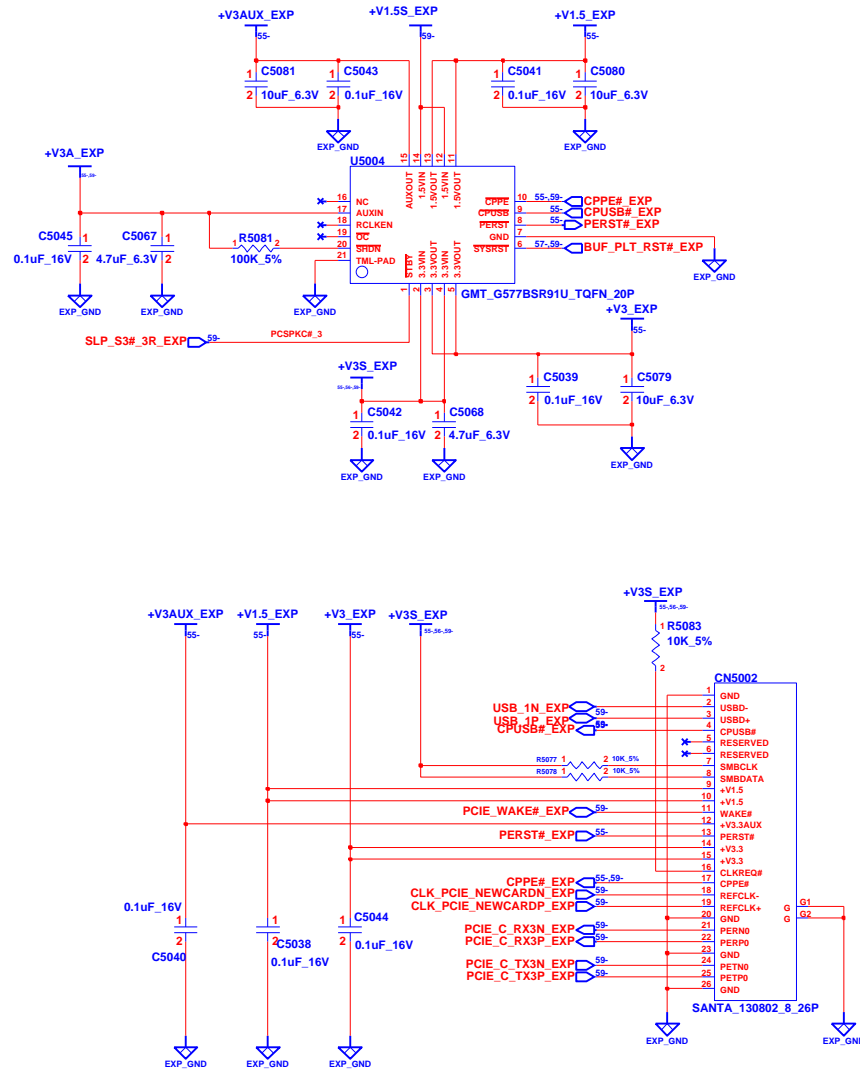
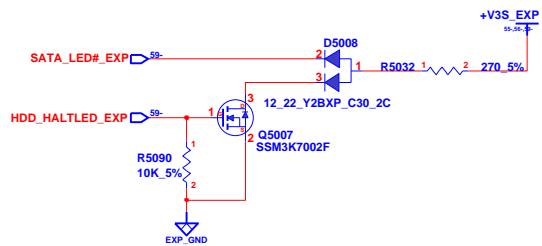

EXPRESS CARD

INVENTEC

TITLE			
Diesel10 - UMA			
EXPRESS CARD & AUDIO DB - 1			
SIZE	CODE	DOC. NUMBER	REV
A3	CS	1310A231601-b-MTR	A01
SHEET		55	OF 61

CHANGE by Y.S. Chu 25-Jan-2010

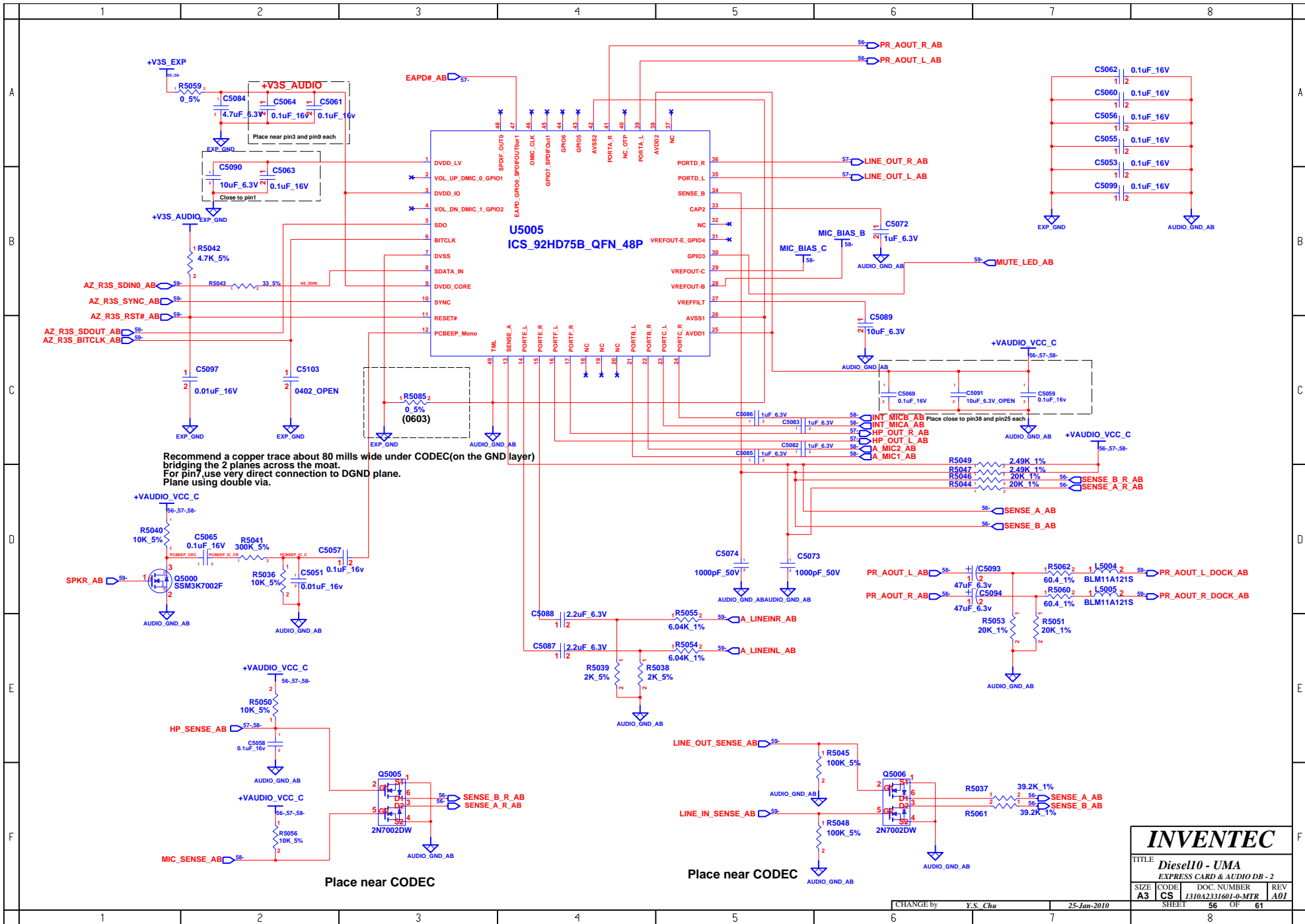

Recommend a copper trace about 80 mills wide under CODEC(on the GND layer) bridging the 2 planes across the moat. For pin7, use very direct connection to DGND plane. Plane using double via.

Place near CODEC

Place near CODEC

INVENTEC			
TITLE: Diesel10 - UMA			
EXPRESS CARD & AUDIO DB - 2			
SIZE	CODE	DOC. NUMBER	REV
A3	CS	1310A2331601-b-MTR	A01
SHEET		56	OF 61

CHANGE by Y.S. Chu 25-Jan-2010

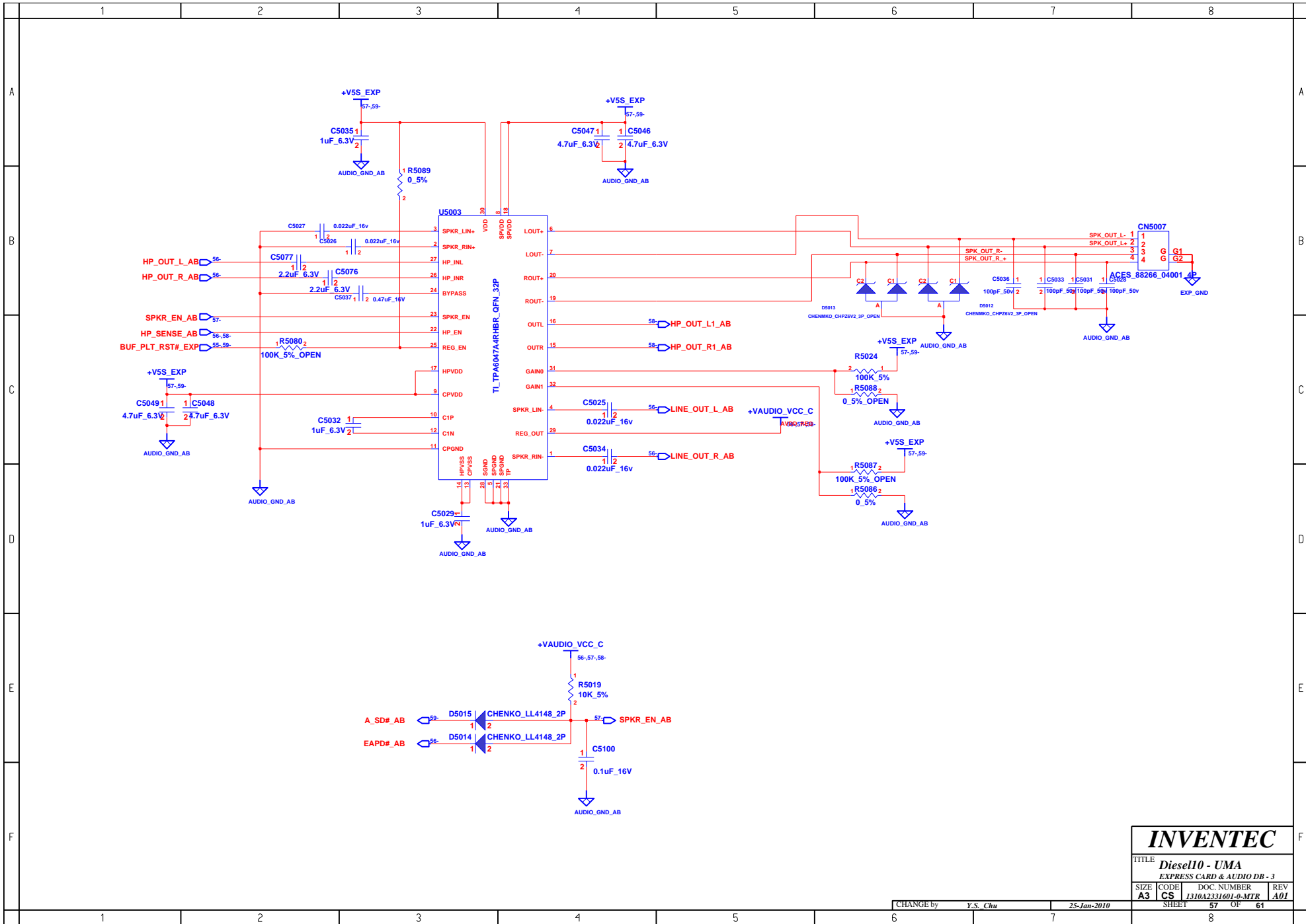

INVENTEC			
TITLE Diesel10 - UMA EXPRESS CARD & AUDIO DB - 3			
SIZE A3	CODE CS	DOC. NUMBER 1310A231601-b-MTR	REV A01
CHANGE by Y.S. Chu		25-Jan-2010	
SHEET 57		OF 61	

<http://sualaptop365.edu.vn>

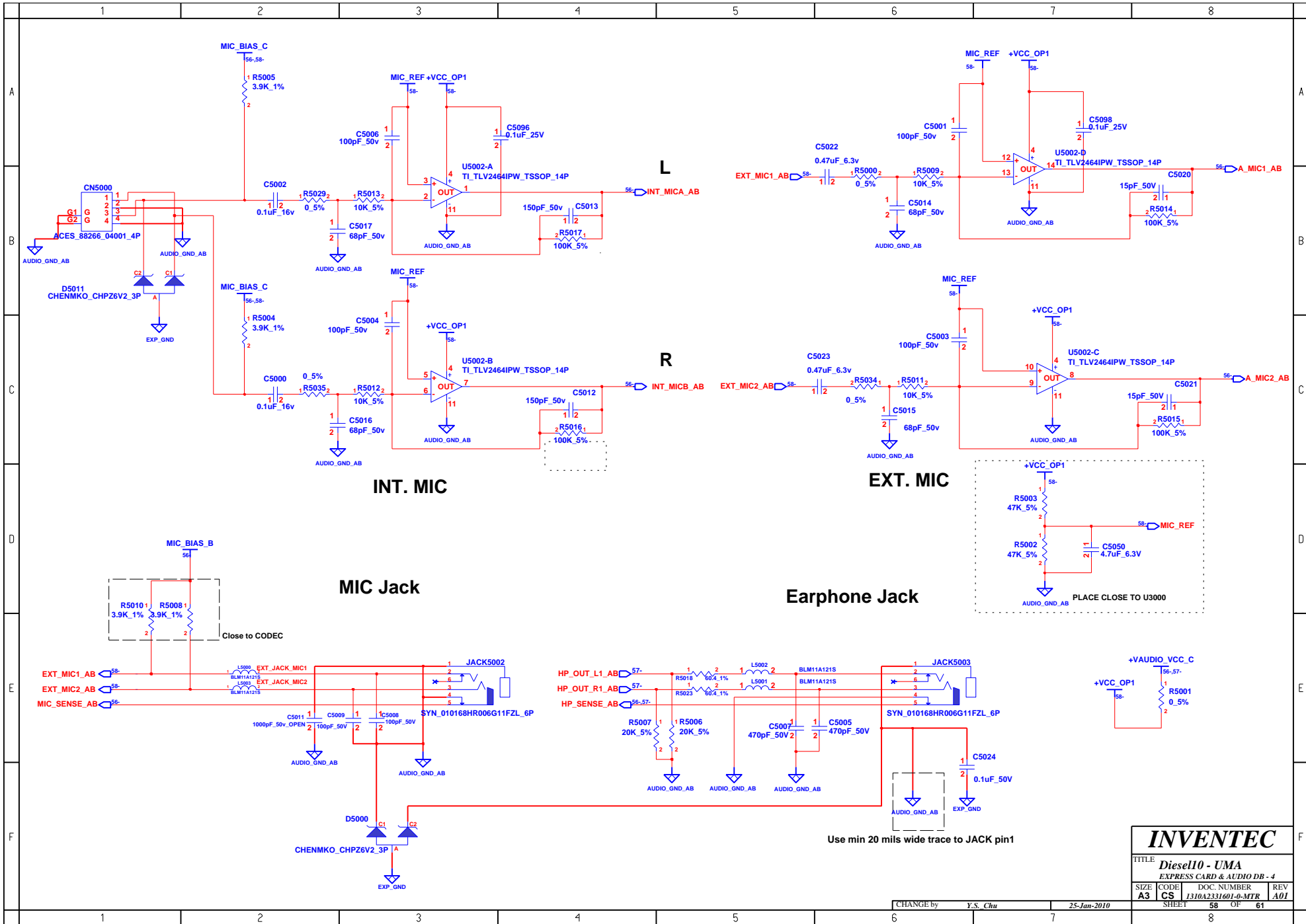

<http://sualaptop365.edu.vn>

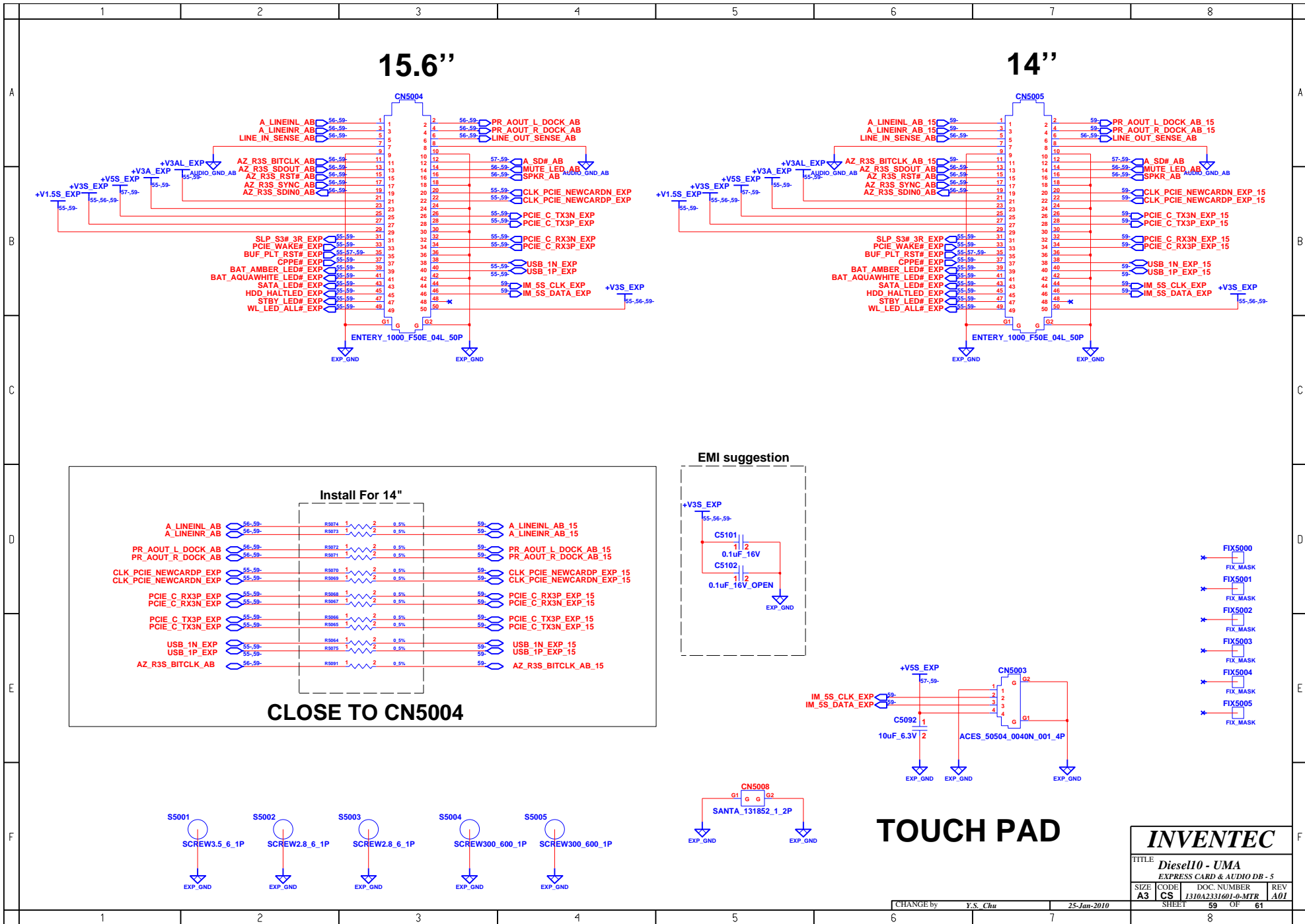

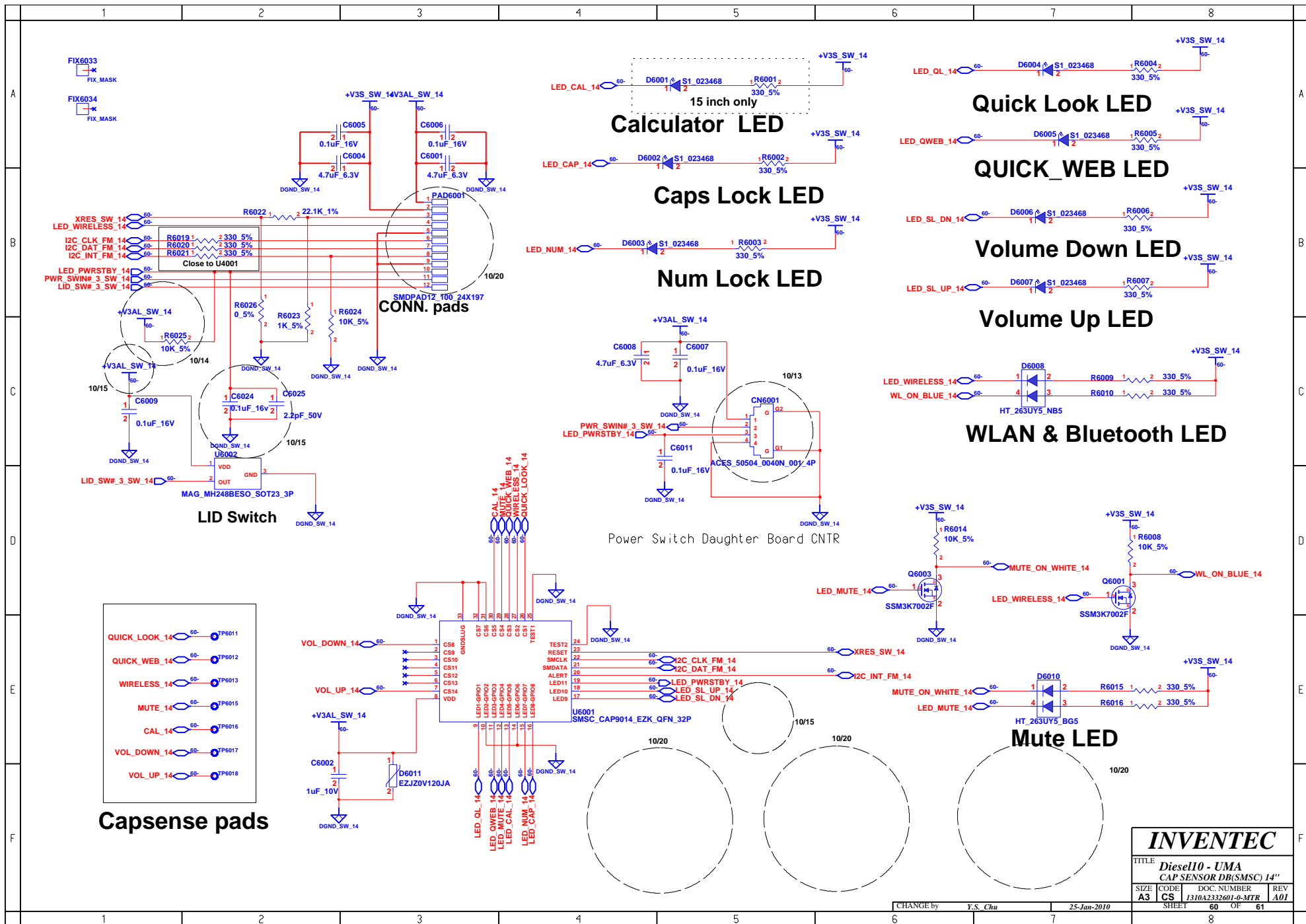

INVENTEC			
TITLE Diesel10 - UMA			
CAP SENSOR DB(SMSC) 14"			
SIZE A3	CODE CS	DOC NUMBER 1310A232601-p-MTR	REV A01
CHANGE by Y.S. Chu		25-Jan-2010	
SHEET 60		OF 61	

