

SHEET TITLE

01	COVER SHEET
02	BOM & PCB MODIFY HISTORY
03	BLOCK DIAGRAM
04	TABLE LIST
05	P4 LGA775 A
06	P4 LGA775 B,D
07	P4 LGA775 C
08	P4 LGA775 E,F,G,H
09	GMCH-BEARLAKE HOST
10	GMCH-BEARLAKE DDRII
11	GMCH-BEARLAKE PCI E, DMI
12	GMCH-BEARLAKE VGA
13	GMCH-BEARLAKE GND
14	GMCH-BEARLAKE PWR
15	DDRII CHANNEL A 1,2
16	DDRII CHANNEL B 1,2
17	DDRII TERMINATION
18	PCI EXPRESS*16 SLOT
19	ICH9 PCI, USB, DMI, LAN
20	ICH9 GPIO, CTRL
21	ICH9 SATA, FAN PWM
22	ICH9 VCC, GND
23	CLOCK GEN CK505
24	PCI EXPRESS*4 ,PCI SLOT 1,2
25	ITE8718GB
26	COM,LPT,CPU FAN,-PROHOT
27	BIOS,CI,HWM,KB/MS

SHEET TITLE

28	AZALIA ALC889
29	AUDIO JACK
30	VCORE PWM ISL6327-6 PHASE
31	DISCRETE POWER
32	ATX POWER,SYS FAN
33	JMicron 1P PATA-JMB368
34	1394 TI TSB43AB23
35	LAN REALTEK RTL8111B/C
36	FRONT PANEL,FUSB,FDD

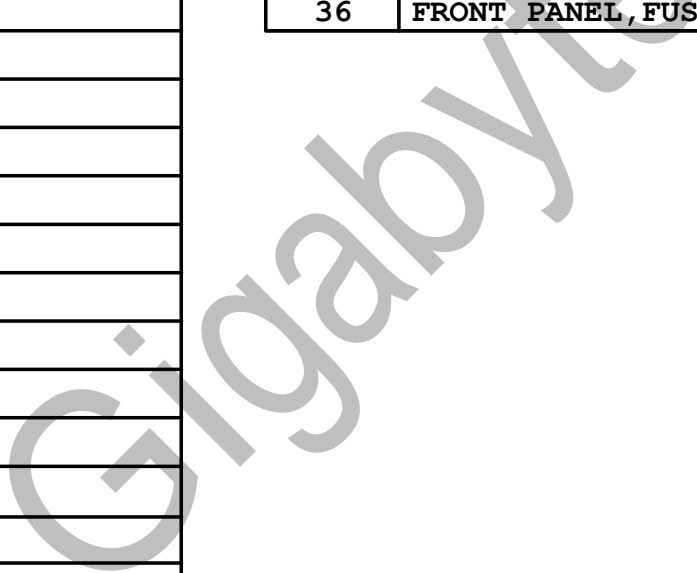



# BLOCK DIAGRAM

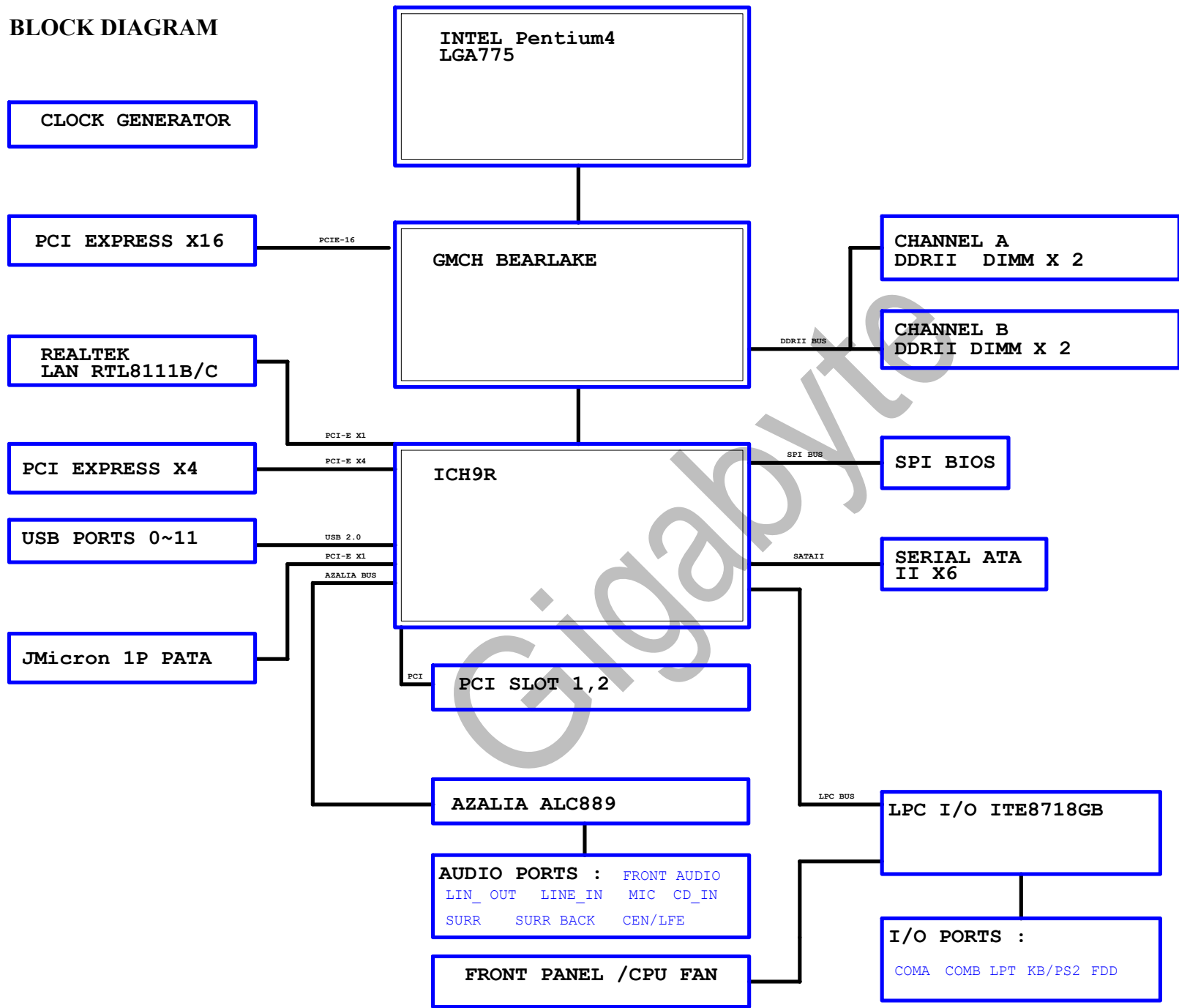

ICH8 GPIO LIST TABLE

PIN NAME	PWR WELL	AFTER/ FLTRST	USAGE	NOTE
GP0	MAIN	IN	-ACZ_DET	P/U 8.2K VCC3
GP1/TACH1	MAIN	IN	N/A	P/U 8.2K VCC3
GP2/PIRQE#	MAIN	IN	-PIRQE	P/U 8.2K VCC3
GP3/PIRQF#	MAIN	IN	-PIRQF	P/U 8.2K VCC3
GP4/PIRQG#	MAIN	IN	-PIRQG	P/U 8.2K VCC3
GP5/PIRQH#	MAIN	IN	-PIRQH	P/U 8.2K VCC3
GP6/TACH2	MAIN	IN	N/A	P/U 8.2K VCC3
GP7/TACH3	MAIN	IN	N/A	P/U 8.2K VCC3
GP8	STBY	IN	GPIO8	P/U 8.2K 3VDUAL
GP9	STBY	OUT	WOL_ONLY	P/D 100K GND
GP10	STBY	OUT	GPIO10	P/U 8.2K 3VDUAL
GP11/SMBALERT#	STBY	OUT	-SMBALRT	P/U 8.2K 3VDUAL
GP12	STBY	IN	MB_ID3	P/U 8.2K 3VDUAL
GP13	STBY	IN	-LPCPME	P/U 8.2K 3VDUAL
GP14	STBY	IN	GPIO14	P/U 8.2K 3VDUAL
GP15	STBY	OUT	GPIO15 (TP)	N/A
GP16	MAIN	IN	MB_ID1	P/U 8.2K VCC3
GP17/TACH0	MAIN	IN	N/A (OPT-ITE)	P/U 8.2K VCC3
GP18	MAIN	IN	MB_ID2	P/U 8.2K VCC3
GP19	MAIN	IN	GPIO19	P/U 8.2K VCC3
GP20	MAIN	OUT	GPIO20	N/A
GP21	MAIN	IN	GPIO21	P/U 8.2K VCC3
GP22	MAIN	IN	GPIO22	P/U 8.2K VCC3
GP23	MAIN	OUT	-LDRQ1	P/U 8.2K VCC3
GP24	STBY	OUT	GPIO24 (TP)	N/A
GP25	STBY	IN	MB_ID4	P/U 8.2K 3VDUAL
GP26/S4_STATE#	STBY	OUT	GPIO26	P/U 8.2K 3VDUAL
GP27	STBY	LOW	GPIO27	ENERGY-LAKE LED:GREEN
GP28	STBY	LOW	GPIO28	ENERGY-LAKE LED:YEL
GP29/OC5#	STBY	IN	-USBOC_F	P/U FUSEVCC1
GP30/OC6#	STBY	IN	-USBOC_F	P/U FUSEVCC1
GP31/OC7#	STBY	IN	-USBOC_F	P/U FUSEVCC1
GP32	MAIN	IN	MB_ID0	P/U 8.2K VCC3
GP33	MAIN	IN	GPIO33	P/U 8.2K VCC3
GP34	MAIN	IN	GPIO34	P/U 8.2K VCC3
GP35	MAIN	IN	N/A (TP)	N/A
GP36	MAIN	IN	GPIO36	P/U 8.2K VCC3
GP37	MAIN	IN	GPIO37	P/U 8.2K VCC3
GP38	MAIN	IN	GPIO38	P/U 8.2K VCC3
GP39	MAIN	IN	GPIO39	P/D 8.2K GND
GP48	MAIN	IN	GPIO48	P/U 8.2K VCC3
GP49	MAIN	IN	CPUPWROK	P/U 100 VTT_OL

VCORE:3 PHASE PWM--ISL6312

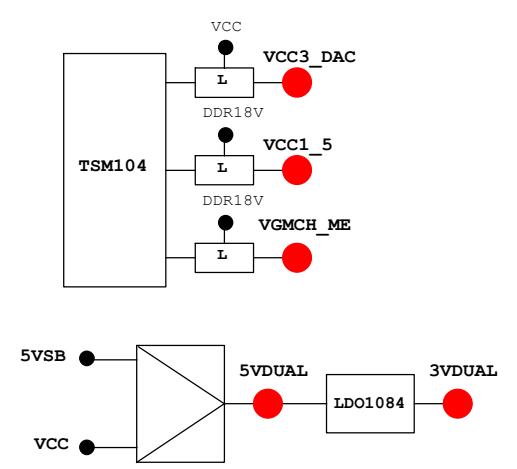
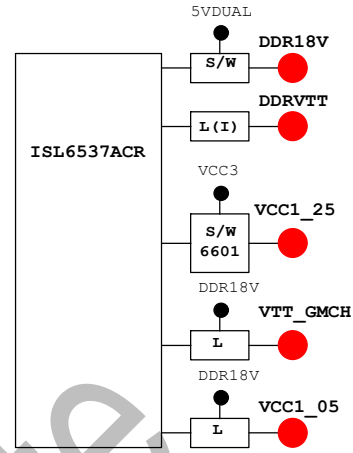
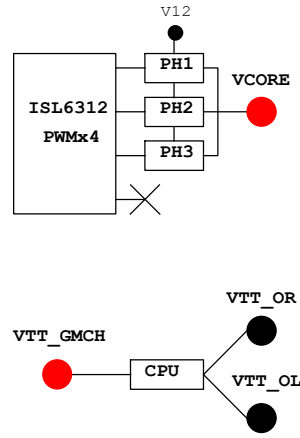

Gigabyte Technology			
Title			
TABLE LIST			
Size B	Document Number	G33M-DS2R	Rev 1.01
Date:	Tuesday, April 03, 2007	Sheet 4	of 36

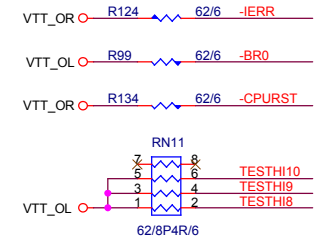
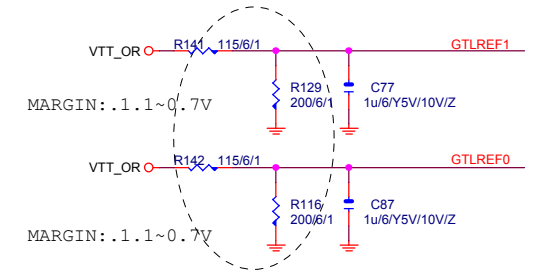
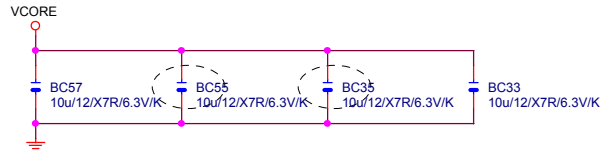
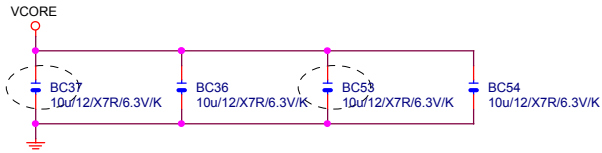

LGA775-39: FOOTPRINT

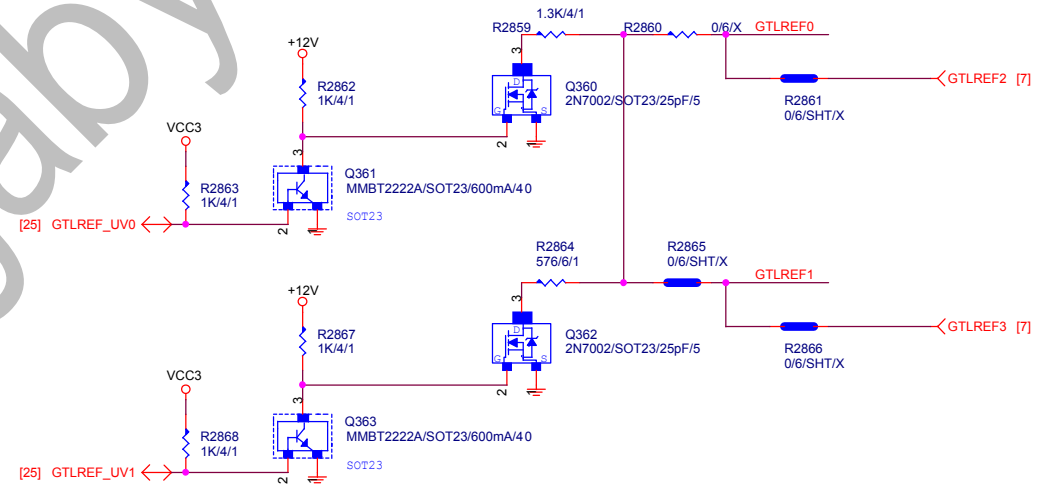
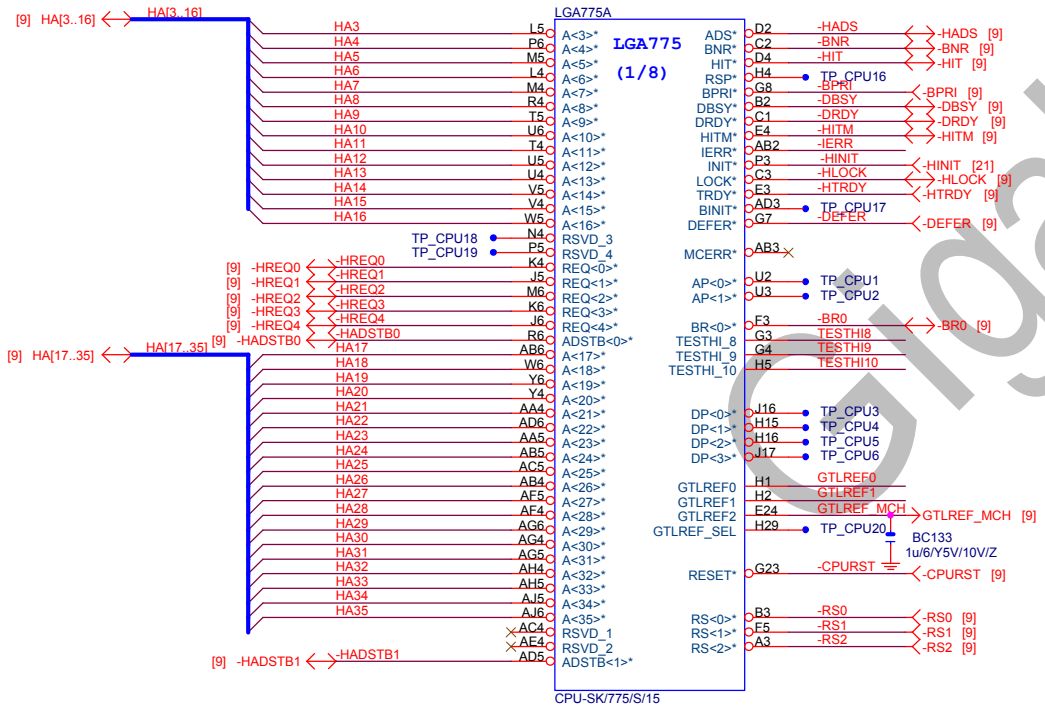

<b>Gigabyte Technology</b>		
Title		
<b>P4_LGA775-A</b>		
Size	Document Number	Rev
B	<b>G33M-DS2R</b>	<b>1.01</b>
Date:	Tuesday, April 03, 2007	Sheet 5 of 36

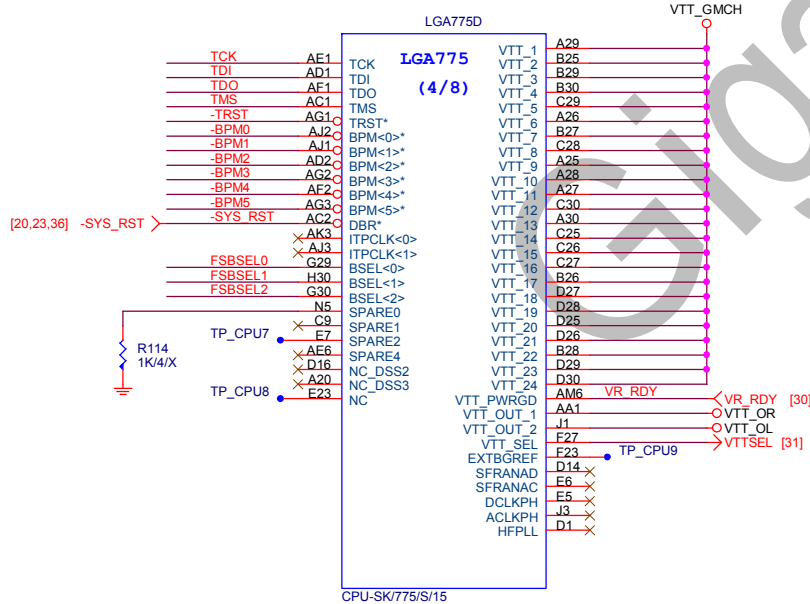
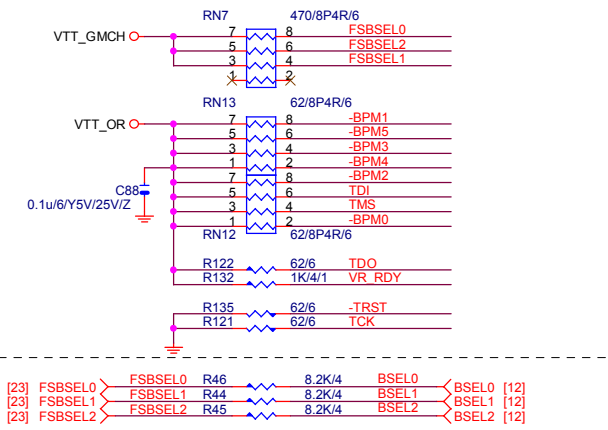
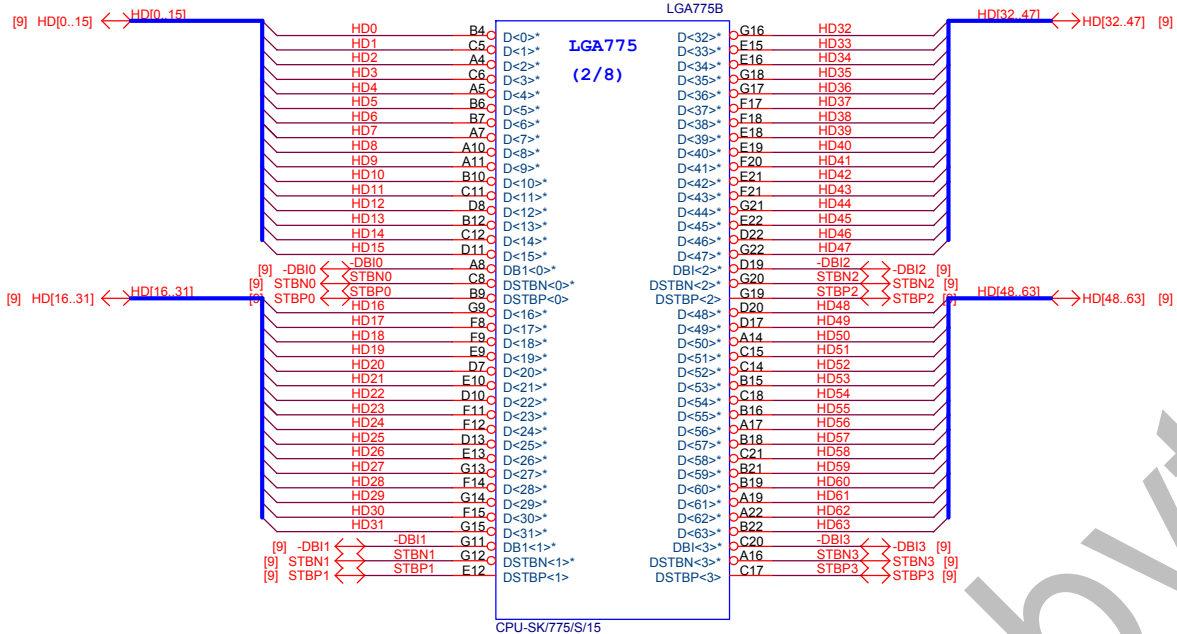

<b>Gigabyte Technology</b>		
Title <b>P4_LGA775-B,D</b>		
Size B	Document Number <b>G33M-DS2R</b>	Rev <b>1.01</b>
Date:	Tuesday, April 03, 2007	Sheet 6 of 36

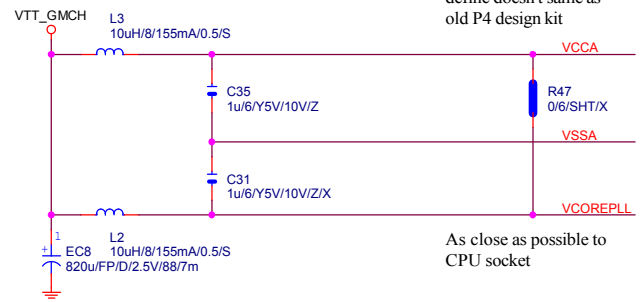

**Note:**  
VCCA & VCOREPLL  
define doesn't same as  
old P4 design kit

Trace width doesn't  
less than 12 Mil

As close as possible to  
CPU socket

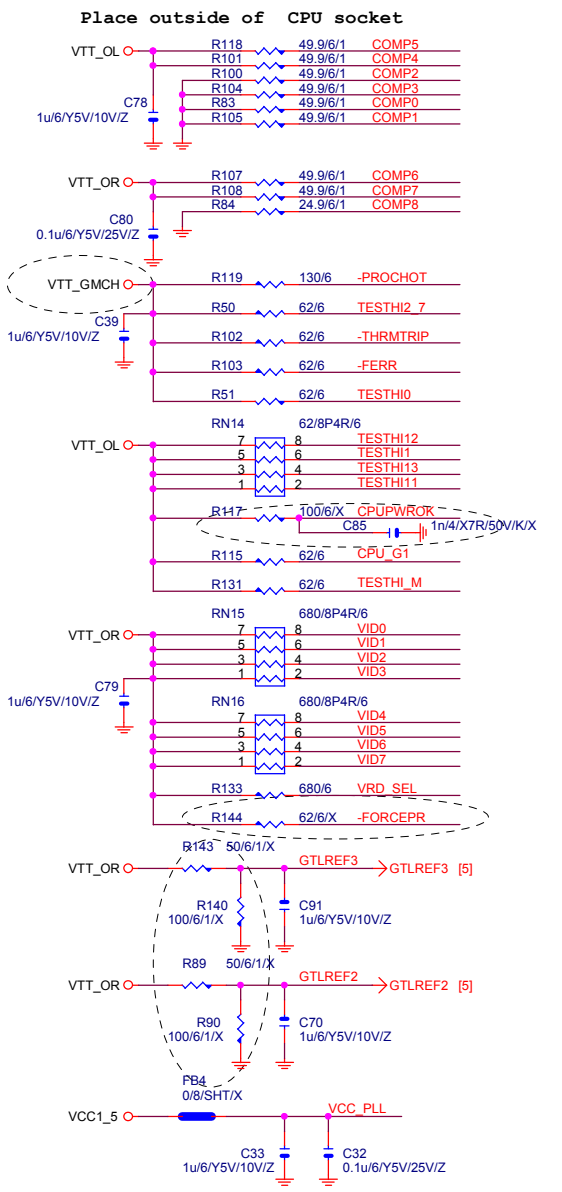
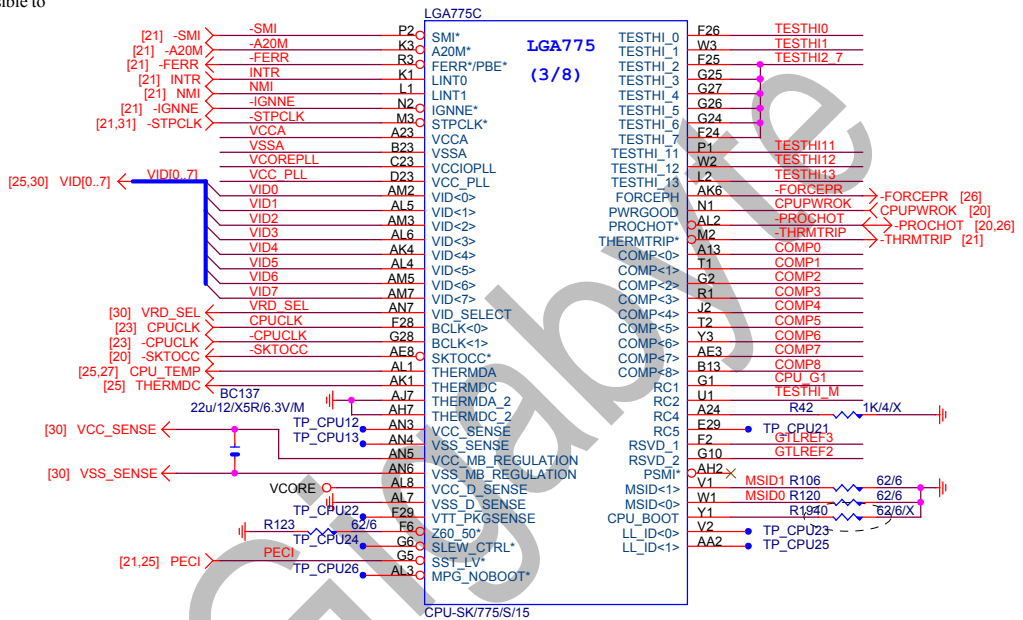

**Gigabyte Technology**

Title		
<b>P4_LGA775-C</b>		
Size B	Document Number	Rev
	<b>G33M-DS2R</b>	<b>1.01</b>
Date:	Tuesday, April 03, 2007	Sheet 7 of 36

PECI:Platform Environment Control Interface

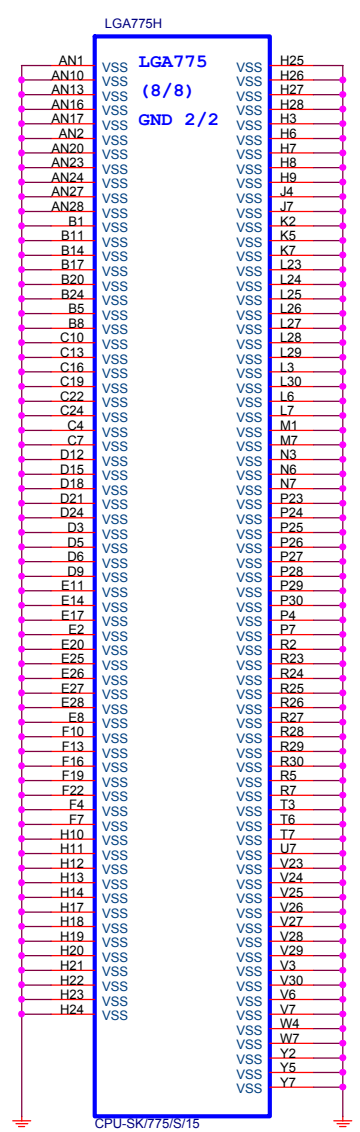
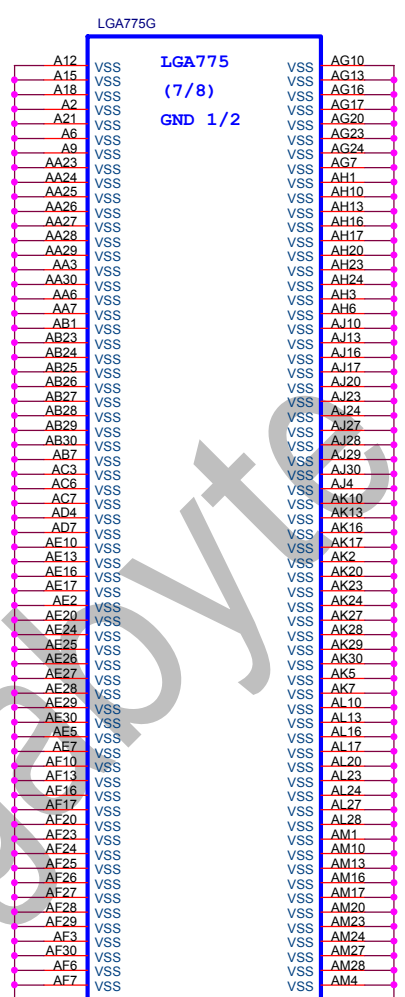
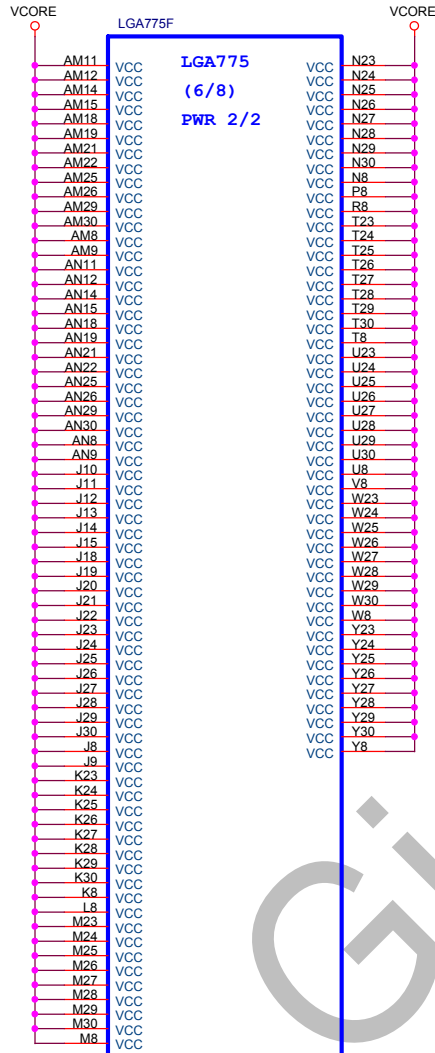
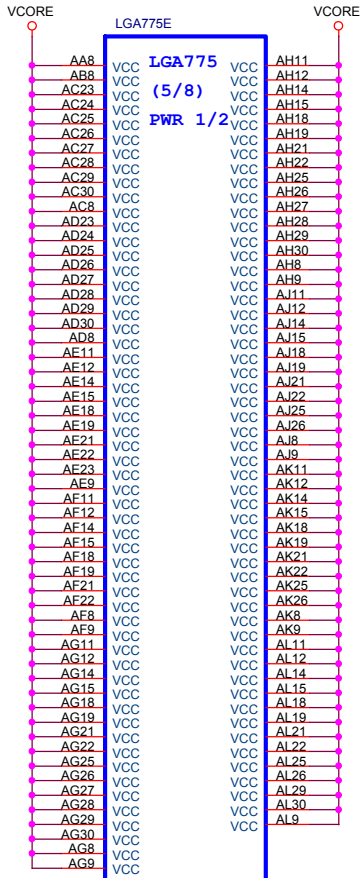

**Gigabyte Technology**

Title			P4_LGA775-E,F,G,H		
Size	Document Number	G33M-DS2R			Rev
B					1.01
Date:	Tuesday, April 03, 2007	Sheet	8	of	36



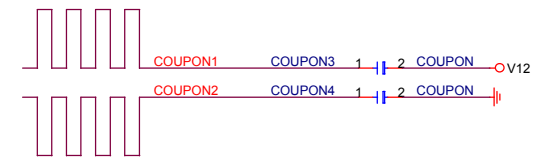
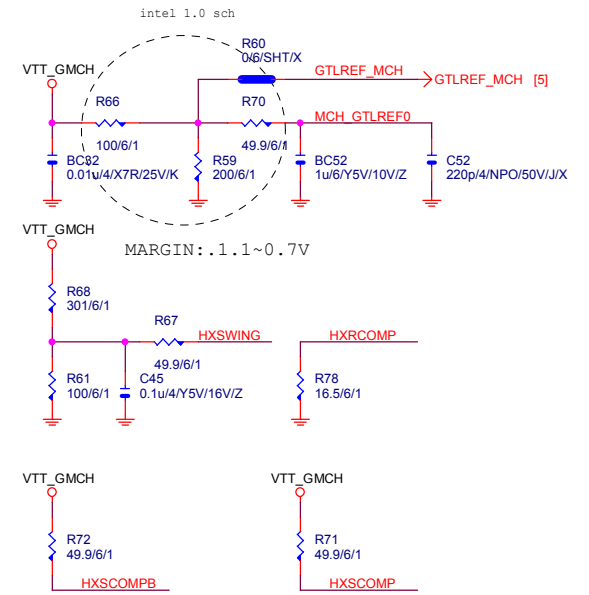
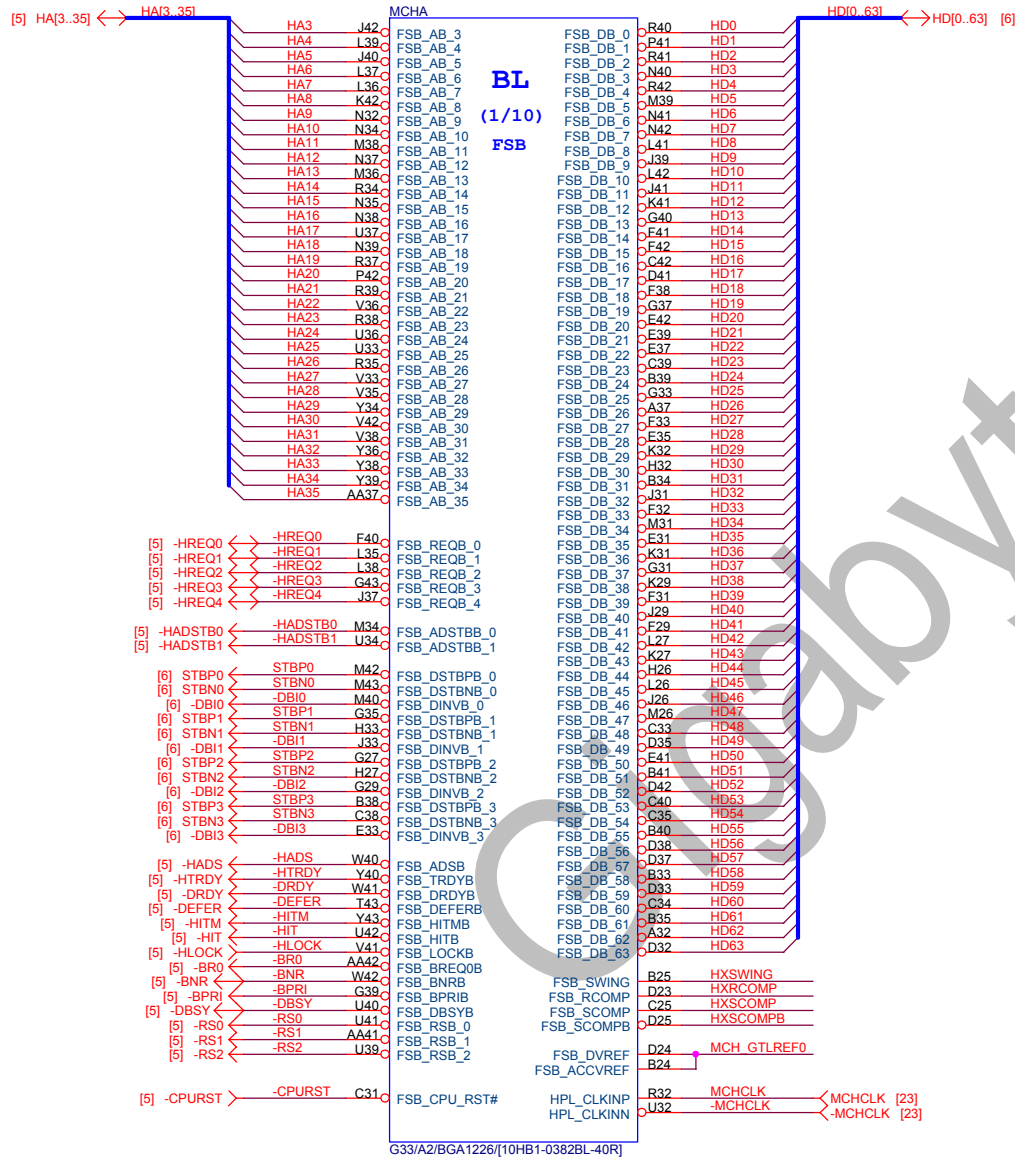

<b>Gigabyte Technology</b>		
Title		
<b>GMCH-HOST</b>		
Size	Document Number	Rev
B	<b>G33M-DS2R</b>	<b>1.01</b>
Date:	Tuesday, April 03, 2007	Sheet 9 of 36



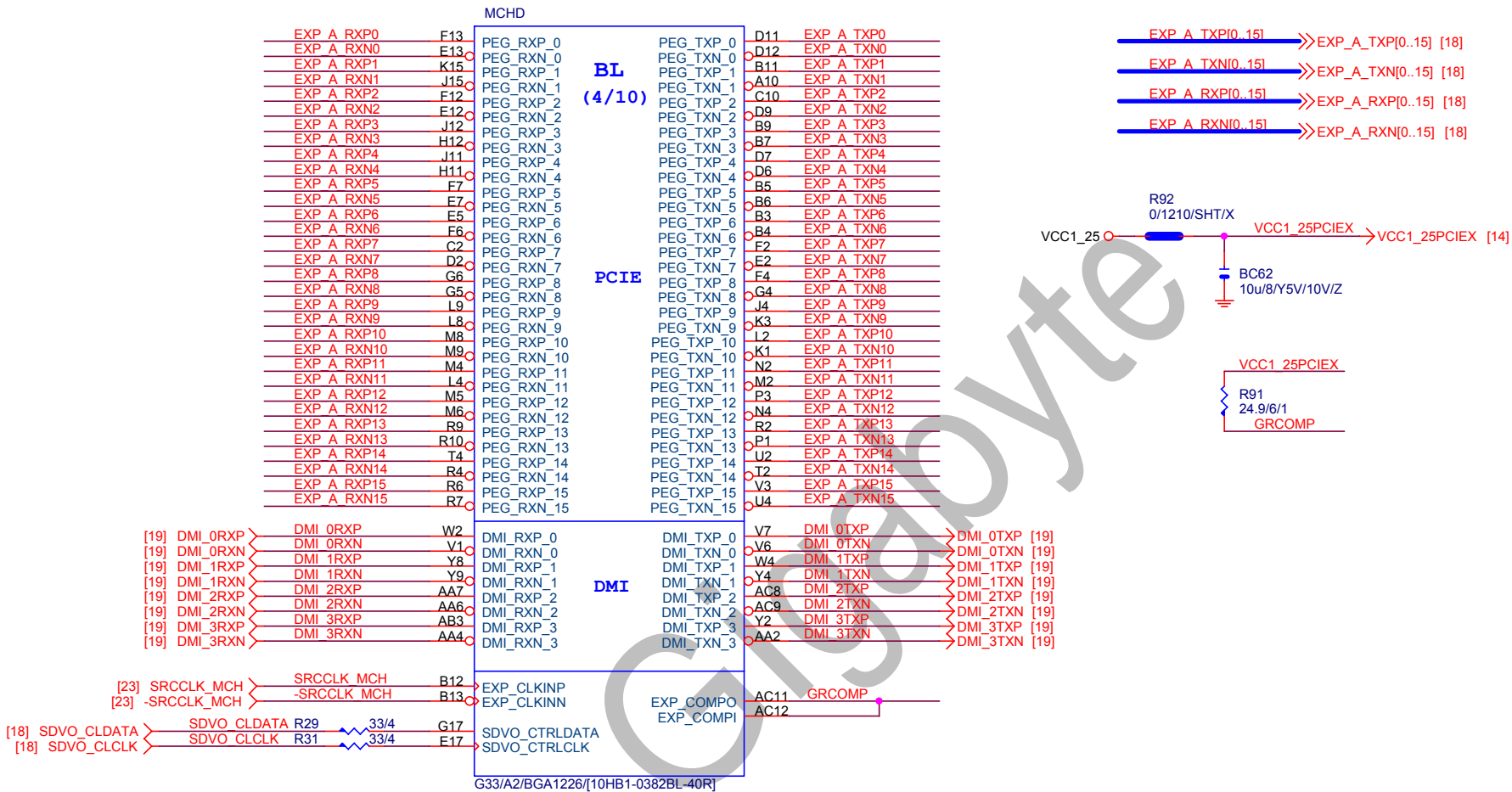

G33/A2/BGA1226([10HB1-0382BL-40R])

**Gigabyte Technology**

Title		
GMCH-PCI E & DMI		
Size	Document Number	Rev
Custom	<b>G33M-DS2R</b>	<b>1.01</b>
Date:	Tuesday, April 03, 2007	Sheet 11 of 36

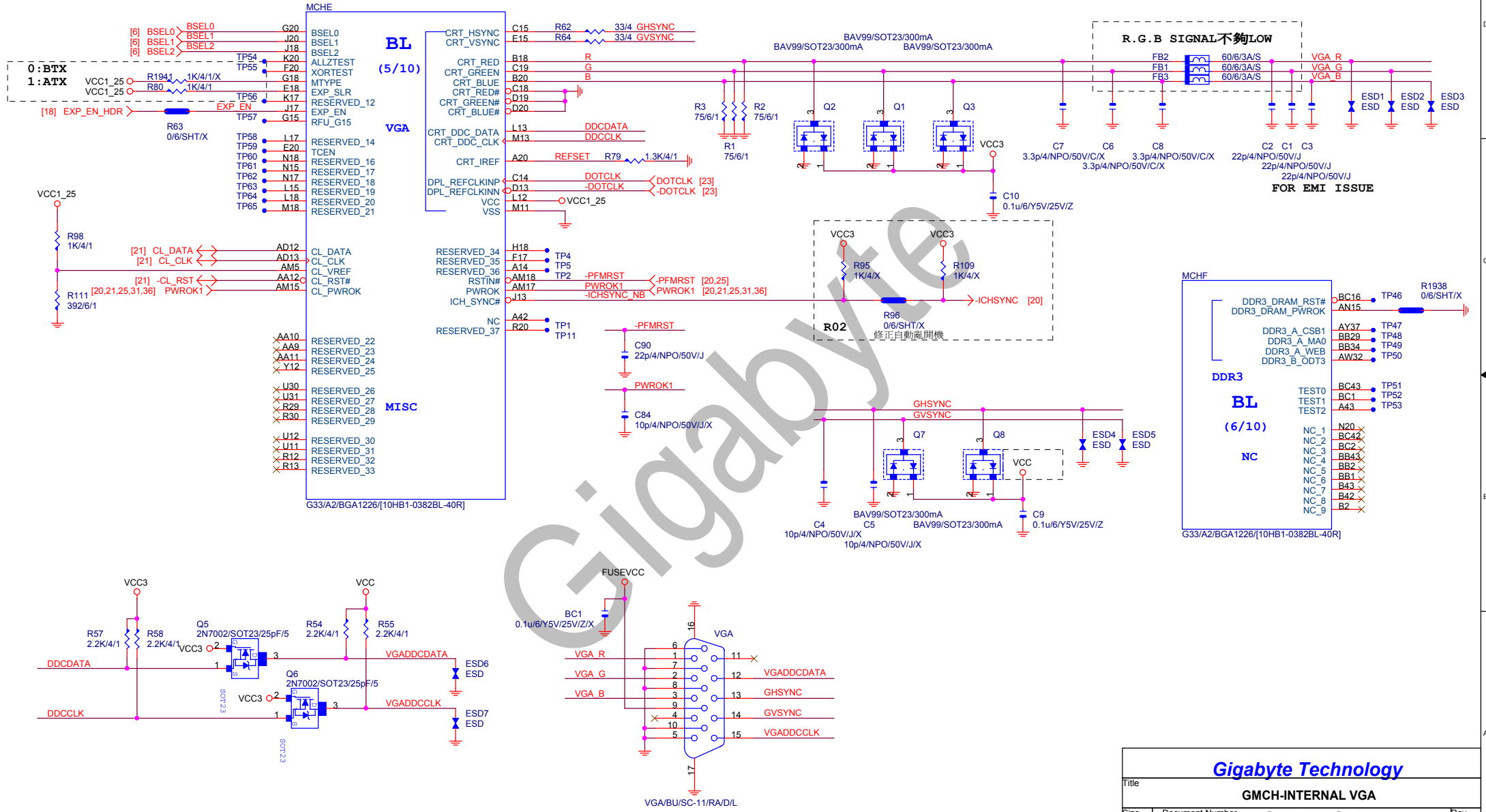

<b>Gigabyte Technology</b>		
Title <b>GMCH-INTERNAL VGA</b>		
Size B	Document Number <b>G33M-DS2R</b>	Rev <b>1.01</b>
Date: Tuesday, April 03, 2007	Sheet 12	of 36

MCHG		
BC37	VSS_1	VSS_181
BC32	VSS_2	VSS_182
BC28	VSS_3	VSS_183
BC24	VSS_4	VSS_184
BC10	VSS_5	VSS_185
BC5	VSS_6	VSS_186
BB7	VSS_7	VSS_187
AY41	VSS_8	VSS_188
AY4	VSS_9	VSS_189
AW43	VSS_10	VSS_190
AW41	VSS_11	VSS_191
AV37	VSS_12	VSS_192
AV35	VSS_13	VSS_193
AV27	VSS_14	VSS_194
AV23	VSS_15	VSS_195
AV21	VSS_16	VSS_196
AV17	VSS_17	VSS_197
AV11	VSS_18	VSS_198
AV9	VSS_19	VSS_199
AV7	VSS_20	VSS_200
AV2	VSS_21	VSS_201
AU42	VSS_22	VSS_202
AU38	VSS_23	VSS_203
AU32	VSS_24	VSS_204
AU24	VSS_25	VSS_205
AU20	VSS_26	VSS_206
AU6	VSS_27	VSS_207
AL4	VSS_28	VSS_208
AT31	VSS_29	VSS_209
AT29	VSS_30	VSS_210
AT15	VSS_31	VSS_211
AT13	VSS_32	VSS_212
AT12	VSS_33	VSS_213
AR38	VSS_34	VSS_214
AR33	VSS_35	VSS_215
AR32	VSS_36	VSS_216
AR27	VSS_37	VSS_217
AR26	VSS_38	VSS_218
AR23	VSS_39	VSS_219
AR21	VSS_40	VSS_220
AR20	VSS_41	VSS_221
AR17	VSS_42	VSS_222
AR9	VSS_43	VSS_223
AR6	VSS_44	VSS_224
AP43	VSS_45	VSS_225
AP24	VSS_46	VSS_226
AP18	VSS_47	VSS_227
AP1	VSS_48	VSS_228
AN38	VSS_49	VSS_229
AN31	VSS_50	VSS_230
AN29	VSS_51	VSS_231
AN24	VSS_52	VSS_232
AN23	VSS_53	VSS_233
AN20	VSS_54	VSS_234
AN13	VSS_55	VSS_235
AN12	VSS_56	VSS_236
AN11	VSS_57	VSS_237
AN4	VSS_58	VSS_238
AM42	VSS_59	VSS_239
AM40	VSS_60	VSS_240
AM36	VSS_61	VSS_241
AM33	VSS_62	VSS_242
AM29	VSS_63	VSS_243
AM24	VSS_64	VSS_244
AM23	VSS_65	VSS_245
AM20	VSS_66	VSS_246
AM11	VSS_67	VSS_247
AM9	VSS_68	VSS_248
AM7	VSS_69	VSS_249
AM4	VSS_70	VSS_250
AL36	VSS_71	VSS_251
AL33	VSS_72	VSS_252
AL31	VSS_73	VSS_253
AK43	VSS_74	VSS_254
AJ39	VSS_75	VSS_255
AJ36	VSS_76	VSS_256
AJ33	VSS_77	VSS_257
AJ32	VSS_78	VSS_258
AH42	VSS_79	VSS_259
AG37	VSS_80	VSS_260
AG34	VSS_81	VSS_261
AF43	VSS_82	VSS_262
AF37	VSS_83	VSS_263
AF36	VSS_84	VSS_264
AF10	VSS_85	VSS_265
AF9	VSS_86	VSS_266
AF8	VSS_87	VSS_267
AF7	VSS_88	VSS_268
AF6	VSS_89	VSS_269
AF5	VSS_90	VSS_270

G33/A2/BGA1226/(10HB1-0382BL-40R)

BL  
(7/10)  
GND

MCHH		
N5	VSS_91	VSS_271
M37	VSS_92	VSS_272
M35	VSS_93	VSS_273
M33	VSS_94	VSS_274
M27	VSS_95	VSS_275
M21	VSS_96	VSS_276
M20	VSS_97	VSS_277
M17	VSS_98	VSS_278
M15	VSS_99	VSS_279
M10	VSS_100	VSS_280
M7	VSS_101	VSS_281
M1	VSS_102	VSS_282
L40	VSS_103	VSS_283
L33	VSS_104	VSS_284
L32	VSS_105	VSS_285
L31	VSS_106	VSS_286
L29	VSS_107	VSS_287
L24	VSS_108	VSS_288
L20	VSS_109	VSS_289
L11	VSS_110	VSS_290
L7	VSS_111	VSS_291
AC7	VSS_112	VSS_292
AC5	VSS_113	VSS_293
AB43	VSS_114	VSS_294
AB25	VSS_115	VSS_295
AB23	VSS_116	VSS_296
AB21	VSS_117	VSS_297
AB19	VSS_118	VSS_298
AB2	VSS_119	VSS_299
AB1	VSS_120	VSS_300
AA38	VSS_121	VSS_301
AA35	VSS_122	VSS_302
AA24	VSS_123	VSS_303
AA22	VSS_124	VSS_304
AA20	VSS_125	VSS_305
AA8	VSS_126	VSS_306
AA5	VSS_127	VSS_307
Y42	VSS_128	VSS_308
H31	VSS_129	VSS_309
H29	VSS_130	VSS_310
H21	VSS_131	VSS_311
H20	VSS_132	VSS_312
H17	VSS_133	VSS_313
H15	VSS_134	VSS_314
H13	VSS_135	VSS_315
G42	VSS_136	VSS_316
G38	VSS_137	VSS_317
G32	VSS_138	VSS_318
G21	VSS_139	VSS_319
G13	VSS_140	VSS_320
G12	VSS_141	VSS_321
G11	VSS_142	VSS_322
G9	VSS_143	VSS_323
G7	VSS_144	VSS_324
G1	VSS_145	VSS_325
F37	VSS_146	VSS_326
F35	VSS_147	VSS_327
F27	VSS_148	VSS_328
F21	VSS_149	VSS_329
F18	VSS_150	VSS_330
F15	VSS_151	VSS_331
F3	VSS_152	VSS_332
E43	VSS_153	VSS_333
E32	VSS_154	VSS_334
E24	VSS_155	VSS_335
E21	VSS_156	VSS_336
E11	VSS_157	VSS_337
E9	VSS_158	VSS_338
E3	VSS_159	VSS_339
D40	VSS_160	VSS_340
D31	VSS_161	VSS_341
D21	VSS_162	VSS_342
D17	VSS_163	VSS_343
D15	VSS_164	VSS_344
D3	VSS_165	VSS_345
C26	VSS_166	VSS_346
C11	VSS_167	VSS_347
C6	VSS_168	VSS_348
C5	VSS_169	VSS_349
C4	VSS_170	VSS_350
B37	VSS_171	VSS_351
B32	VSS_172	VSS_352
B31	VSS_173	VSS_353
B26	VSS_174	VSS_354
B23	VSS_175	VSS_355
B22	VSS_176	VSS_356
B19	VSS_177	VSS_357
B14	VSS_178	VSS_358
D16	VSS_179	VSS_359
M11	VSS_180????	VSS_360

G33/A2/BGA1226/(10HB1-0382BL-40R)

BL  
(8/10)  
GND

B10	VSS_271
A39	VSS_272
A34	VSS_273
A26	VSS_274
A18	VSS_275
A12	VSS_276
A7	VSS_277
BC41	VSS_278
BC3	VSS_279
BA1	VSS_280
AY40	VSS_281
AF23	VSS_282
AF21	VSS_283
AF19	VSS_284
AE18	VSS_285
AC18	VSS_286
AA18	VSS_287
V29	VSS_288
U29	VSS_289
U27	VSS_290
R21	VSS_291
E1	VSS_292
C43	VSS_293
C1	VSS_294
A41	VSS_295
A5	VSS_296
A3	VSS_297
V30	VSS_298

**Gigabyte Technology**

Title		
GMCH-GND		
Size Custom	Document Number	Rev
	<b>G33M-DS2R</b>	<b>1.01</b>
Date:	Tuesday, April 03, 2007	Sheet 13 of 36









# DDR TERMINATION CHANNEL A

## DDRVTT Decouple

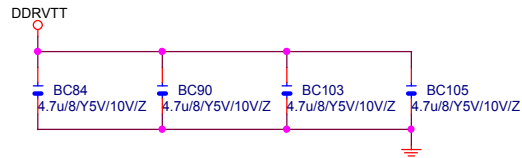
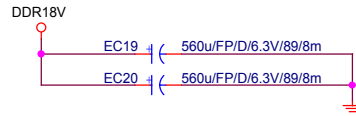
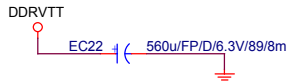

## DDR18V Decouple

## DDRVTT Decouple

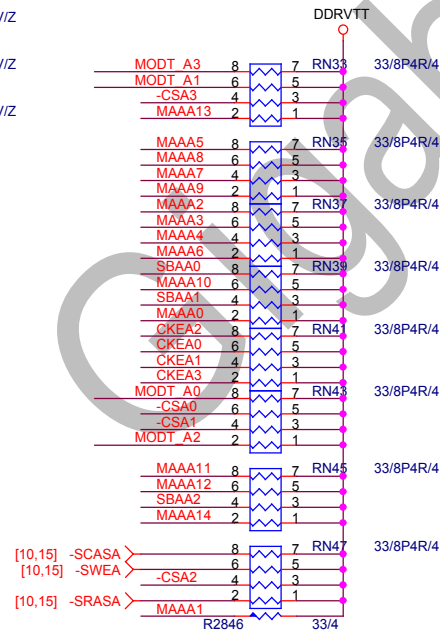
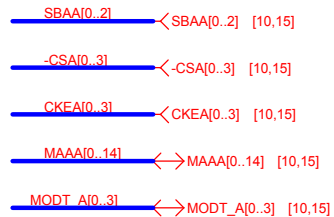
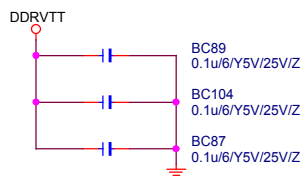
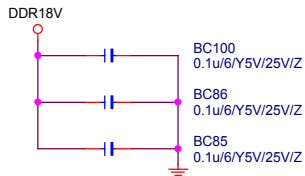

# DDR TERMINATION CHANNEL B

## DDR18V Decouple

## DDRVTT Decouple

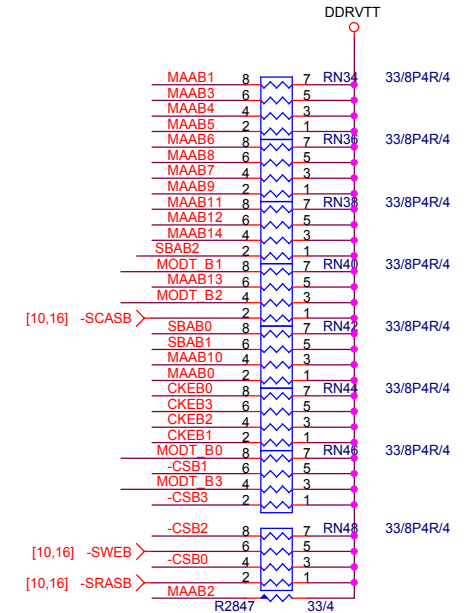
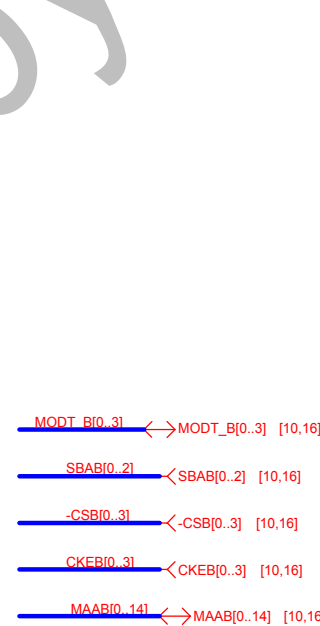
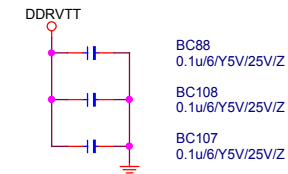
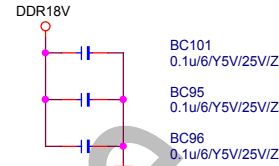

Gigabyte Technology

Title			DDR II TERMINATOR		
Size	Document Number	G33M-DS2R			Rev
Custom					1.01
Date:	Tuesday, April 03, 2007	Sheet	17	of	36

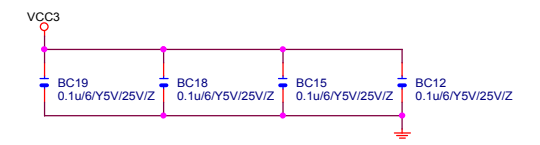
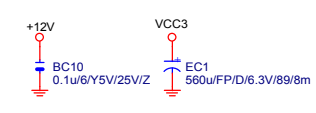
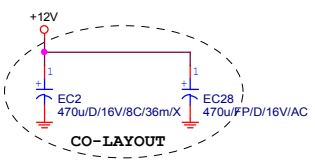

EXP A TXP0\_15] >>> EXP\_A\_TXP0[0..15] [11]  
 EXP A TXN0\_15] >>> EXP\_A\_TXN0[0..15] [11]

EXP A TXP0	C28	0.1u4/Y5V/16V/Z	EXP A TXP0C
EXP A TXN0	C27	0.1u4/Y5V/16V/Z	EXP A TXN0C
EXP A TXP1	C29	0.1u4/Y5V/16V/Z	EXP A TXP1C
EXP A TXN1	C34	0.1u4/Y5V/16V/Z	EXP A TXN1C
EXP A TXP2	C37	0.1u4/Y5V/16V/Z	EXP A TXP2C
EXP A TXN2	C38	0.1u4/Y5V/16V/Z	EXP A TXN2C
EXP A TXP3	C40	0.1u4/Y5V/16V/Z	EXP A TXP3C
EXP A TXN3	C41	0.1u4/Y5V/16V/Z	EXP A TXN3C
EXP A TXP4	C43	0.1u4/Y5V/16V/Z	EXP A TXP4C
EXP A TXN4	C44	0.1u4/Y5V/16V/Z	EXP A TXN4C
EXP A TXP5	C47	0.1u4/Y5V/16V/Z	EXP A TXP5C
EXP A TXN5	C46	0.1u4/Y5V/16V/Z	EXP A TXN5C
EXP A TXP6	C49	0.1u4/Y5V/16V/Z	EXP A TXP6C
EXP A TXN6	C48	0.1u4/Y5V/16V/Z	EXP A TXN6C
EXP A TXP7	C51	0.1u4/Y5V/16V/Z	EXP A TXP7C
EXP A TXN7	C50	0.1u4/Y5V/16V/Z	EXP A TXN7C
EXP A TXP8	C55	0.1u4/Y5V/16V/Z	EXP A TXP8C
EXP A TXN8	C56	0.1u4/Y5V/16V/Z	EXP A TXN8C
EXP A TXP9	C59	0.1u4/Y5V/16V/Z	EXP A TXP9C
EXP A TXN9	C60	0.1u4/Y5V/16V/Z	EXP A TXN9C
EXP A TXP10	C64	0.1u4/Y5V/16V/Z	EXP A TXP10C
EXP A TXN10	C61	0.1u4/Y5V/16V/Z	EXP A TXN10C
EXP A TXP11	C66	0.1u4/Y5V/16V/Z	EXP A TXP11C
EXP A TXN11	C65	0.1u4/Y5V/16V/Z	EXP A TXN11C
EXP A TXP12	C68	0.1u4/Y5V/16V/Z	EXP A TXP12C
EXP A TXN12	C67	0.1u4/Y5V/16V/Z	EXP A TXN12C
EXP A TXP13	C71	0.1u4/Y5V/16V/Z	EXP A TXP13C
EXP A TXN13	C69	0.1u4/Y5V/16V/Z	EXP A TXN13C
EXP A TXP14	C73	0.1u4/Y5V/16V/Z	EXP A TXP14C
EXP A TXN14	C72	0.1u4/Y5V/16V/Z	EXP A TXN14C
EXP A TXP15	C75	0.1u4/Y5V/16V/Z	EXP A TXP15C
EXP A TXN15	C74	0.1u4/Y5V/16V/Z	EXP A TXN15C

PCIESLOT-164DN-2

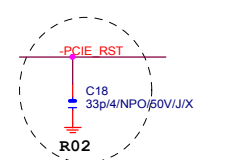
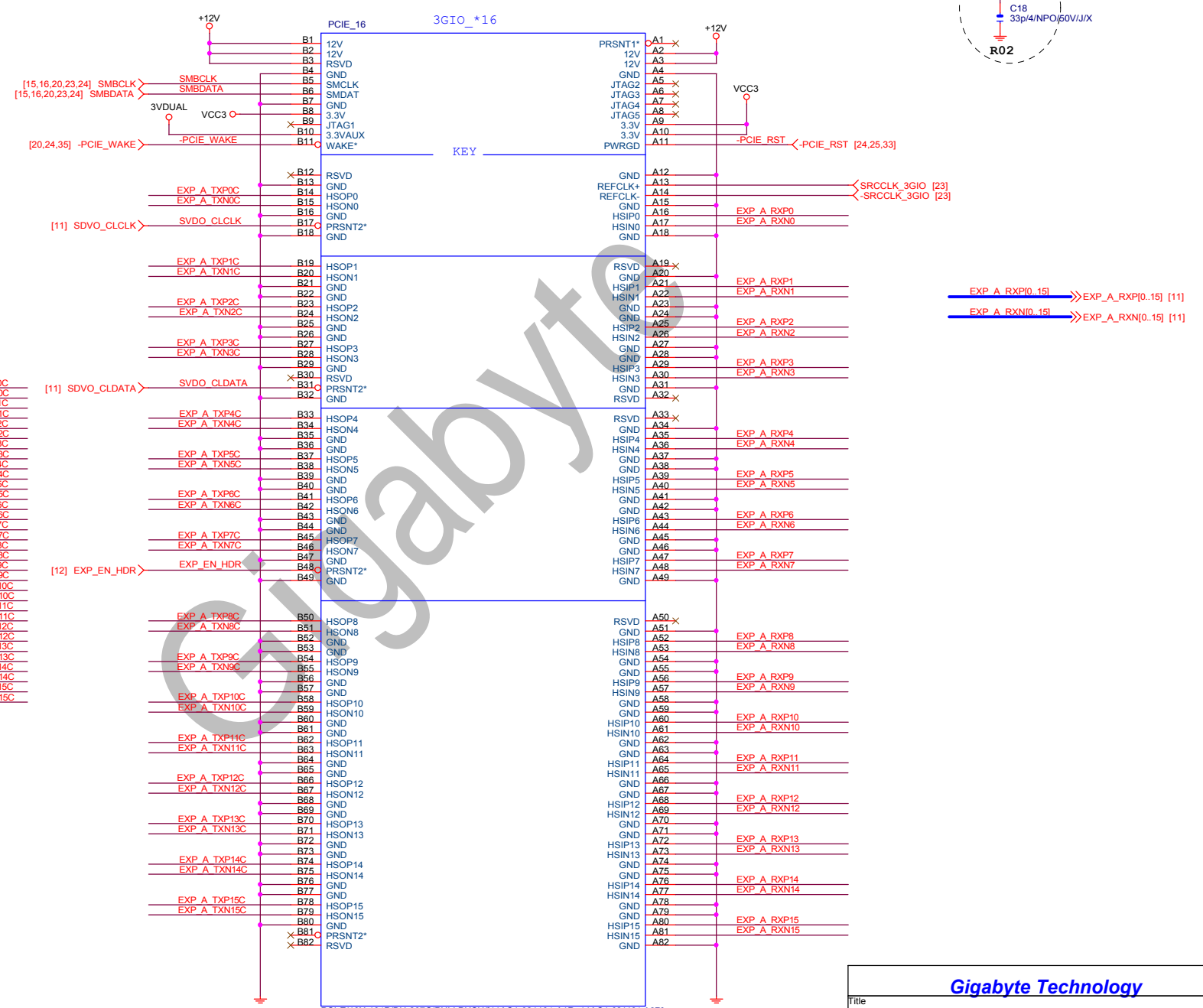

Gigabyte Technology

Title		
PCI EXPRESS * 16		
Size	Document Number	Rev
Custom	G33M-DS2R	1.01
Date:	Tuesday, April 03, 2007	Sheet 18 of 36

BLUE

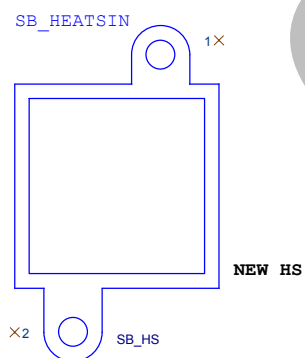
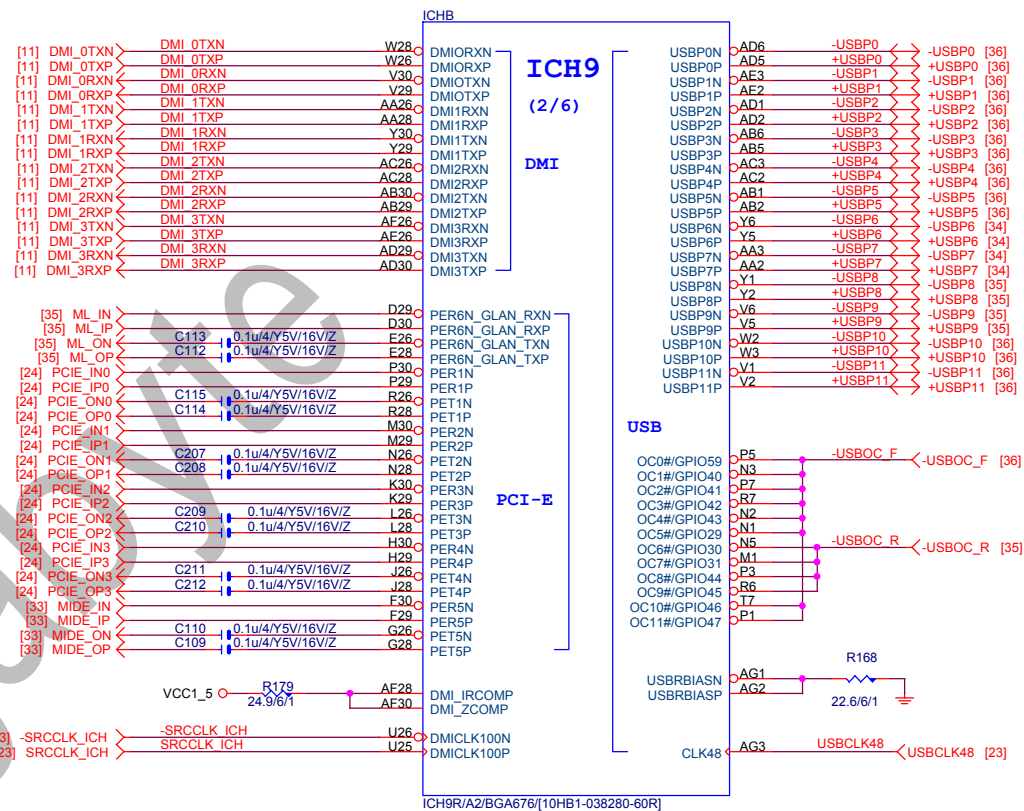
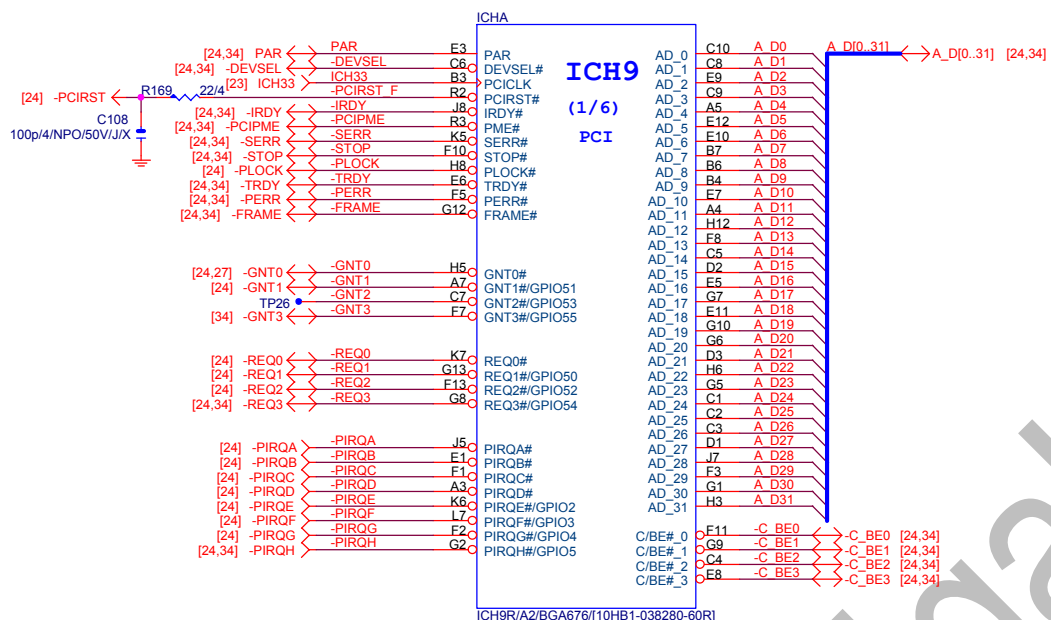

<b>Gigabyte Technology</b>		
Title <b>ICH9-PCI, DMI, LAN, USB</b>		
Size B	Document Number <b>G33M-DS2R</b>	Rev <b>1.0</b>
Date:	Tuesday, April 03, 2007	Sheet 19 of 36



修改成VCC3,  
否則造成不開機  
,-PCIRST/-PFMRST不會打

INTEL NOTE:SATAII PORT  
ICH9: 4(0/1/4/5 PORT,2/3:N/A)

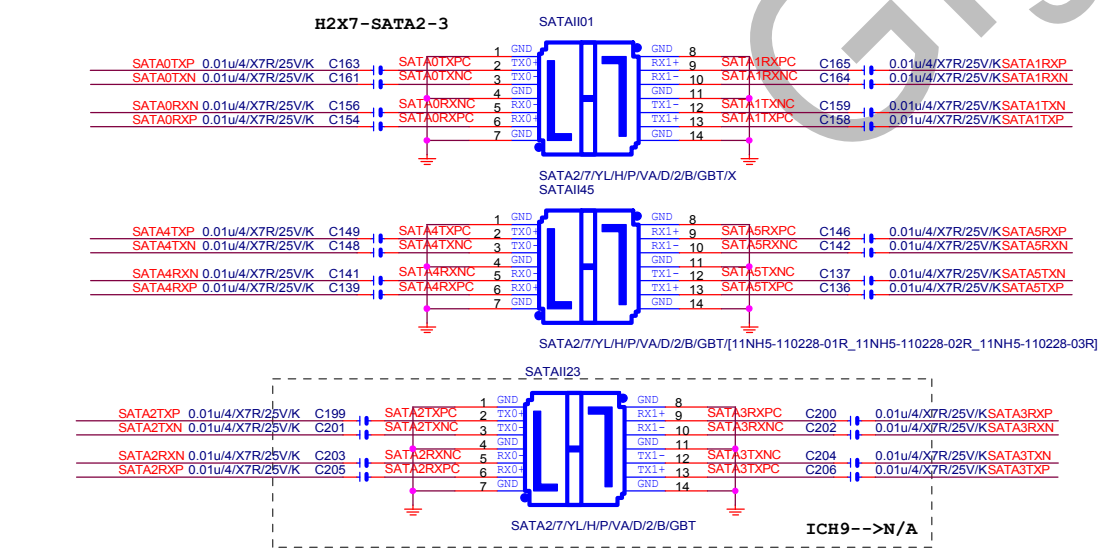
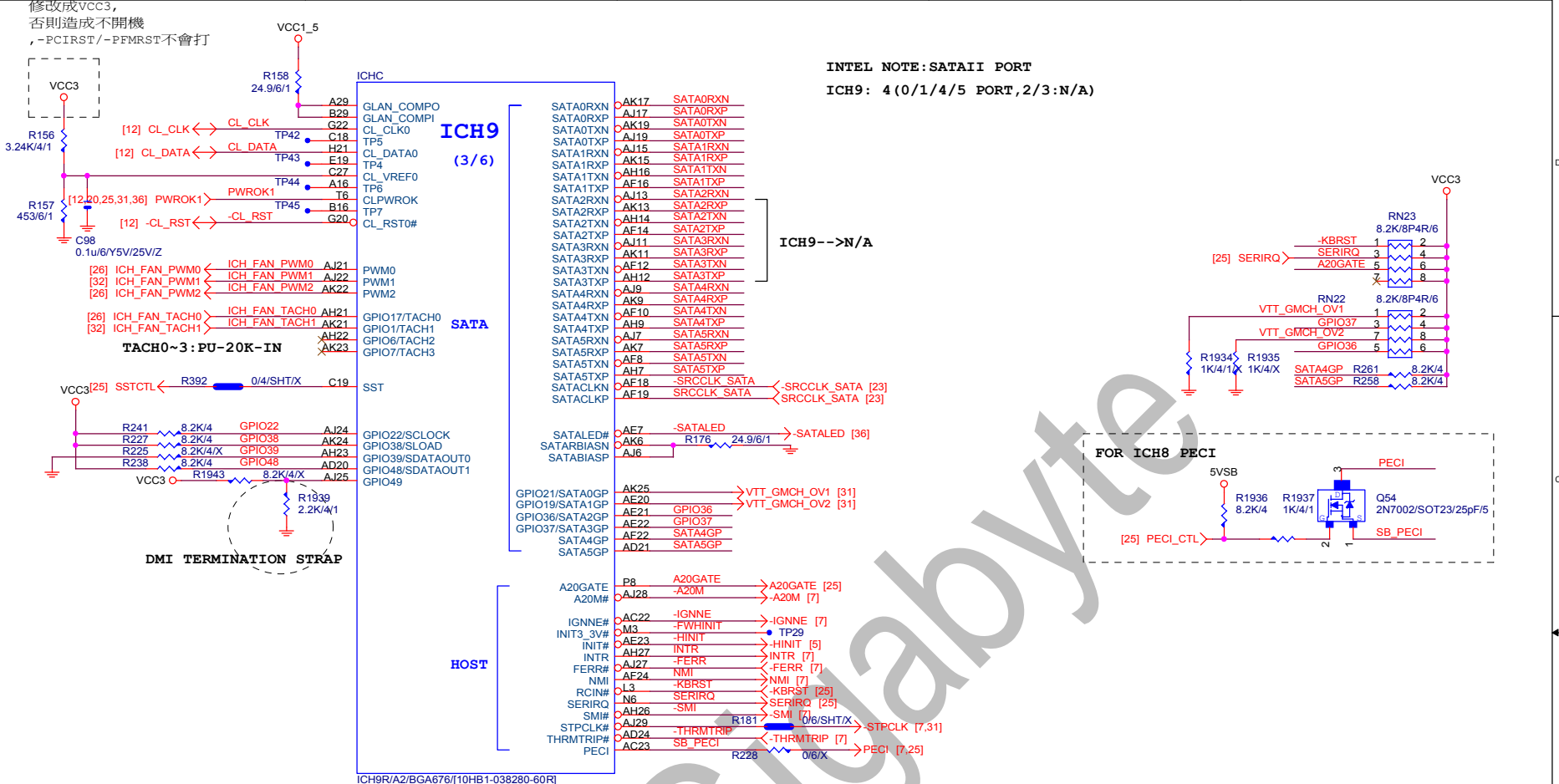

<b>Gigabyte Technology</b>		
Title <b>ICH9- SATA, FAN CTRL</b>		
Size Custom	Document Number <b>G33M-DS2R</b>	Rev <b>1.01</b>
Date: Tuesday, April 03, 2007	Sheet 21	of 36

G30	VSS_100	H13
G29	VSS_101	H19
G28	VSS_102	H22
G16	VSS_103	H25
F9	VSS_104	H26
F8	VSS_105	H9
F28	VSS_106	H29
F26	VSS_107	J29
F21	VSS_108	J30
F12	VSS_109	J6
E30	VSS_110	K26
E29	VSS_111	K28
E22	VSS_112	L2
E2	VSS_113	L23
E18	VSS_114	L29
E15	VSS_115	L30
D28	VSS_116	M14
D8	VSS_117	M16
B5	VSS_118	M28
B28	VSS_119	M8
B25	VSS_120	M28
B22	VSS_121	M8
B2	VSS_122	M13
B19	VSS_123	M14
B17	VSS_124	M16
B14	VSS_125	M28
B11	VSS_126	N17
AK3	VSS_127	N18
AK30	VSS_128	N23
AK29	VSS_129	N29
AK2	VSS_130	N30
AK16	VSS_131	AA23
AK14	VSS_132	AA24
AK12	VSS_133	AA25
A18	VSS_134	P14
A15	VSS_135	P15
A126	VSS_136	P16
A123	VSS_137	P17
A120	VSS_138	P18
A116	VSS_139	P19
A114	VSS_140	P2
A112	VSS_141	P26
AH8	VSS_142	P28
AH6	VSS_143	P6
AH20	VSS_144	R13
AH2	VSS_145	R14
AH19	VSS_146	R15
AH15	VSS_147	R16
AH13	VSS_148	R17
AG28	VSS_149	R18
AF9	VSS_150	R23
AF7	VSS_151	R29
AF29	VSS_152	R30
AF25	VSS_153	R8
AF23	VSS_154	T12
AF20	VSS_155	T13
AF15	VSS_156	T14
AF13	VSS_157	T16
AE9	VSS_158	T16
AE8	VSS_159	T17
AE6	VSS_160	T18
AE5	VSS_161	T19
AE25	VSS_162	T2
AE19	VSS_163	T29
AE18	VSS_164	T5
AE16	VSS_165	U13
AE15	VSS_166	U15
AE14	VSS_167	U16
AE13	VSS_168	U16
AE12	VSS_169	U17
AE10	VSS_170	U23
AD9	VSS_171	V13
AD7	VSS_172	V14
AD3	VSS_173	V15
AD22	VSS_174	V16
AD19	VSS_175	V17
AD18	VSS_176	V18
AD16	VSS_177	V26
AD15	VSS_178	V28
AD14	VSS_179	V3
AC8	VSS_180	V3
AC5	VSS_181	V18
AC3	VSS_182	W14
AC30	VSS_183	W16
AC24	VSS_184	W23
AC12	VSS_185	W30
AC1	VSS_186	W5
AB28	VSS_187	W6
AB26	VSS_188	Y28
AA6	VSS_189	Y3
AA5	VSS_190	Y7
AK27	VSS_191	AA29
AH29	VSS_192	AA1
AJ4	VSS_193	AA2
AF3	VSS_194	AA3
B27	VSS_195	AA4
	VSS_196	AA5
	VSS_197	AA6
	VSS_198	AA7
	VSS_199	AA8
	VSS_200	AA9
	VSS_201	AA10

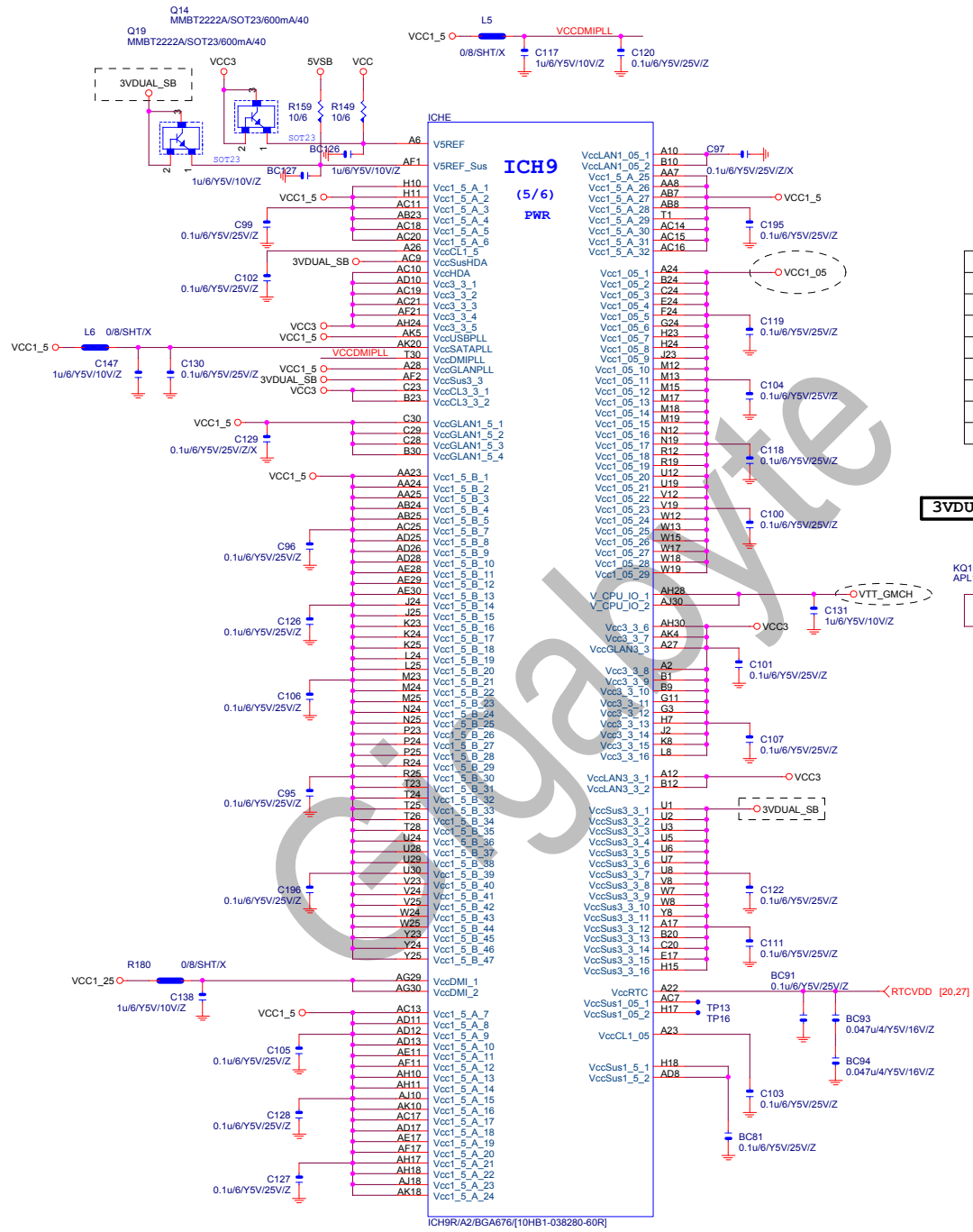

SIGNAL NAME	NO LAN
VccCL_1_05	de-CAP
VccCL3_3	Vcc3_3
VccCL1_5	de-CAP
VccGLAN1_5	Vcc1_5
VccGLAN3_3	Vcc3_3
VccGLANPLL	Vcc1_5
VccLAN1_05	N/A
VccLAN3_3	Vcc3_3

**3VDUAL\_SB**

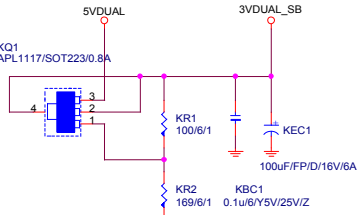

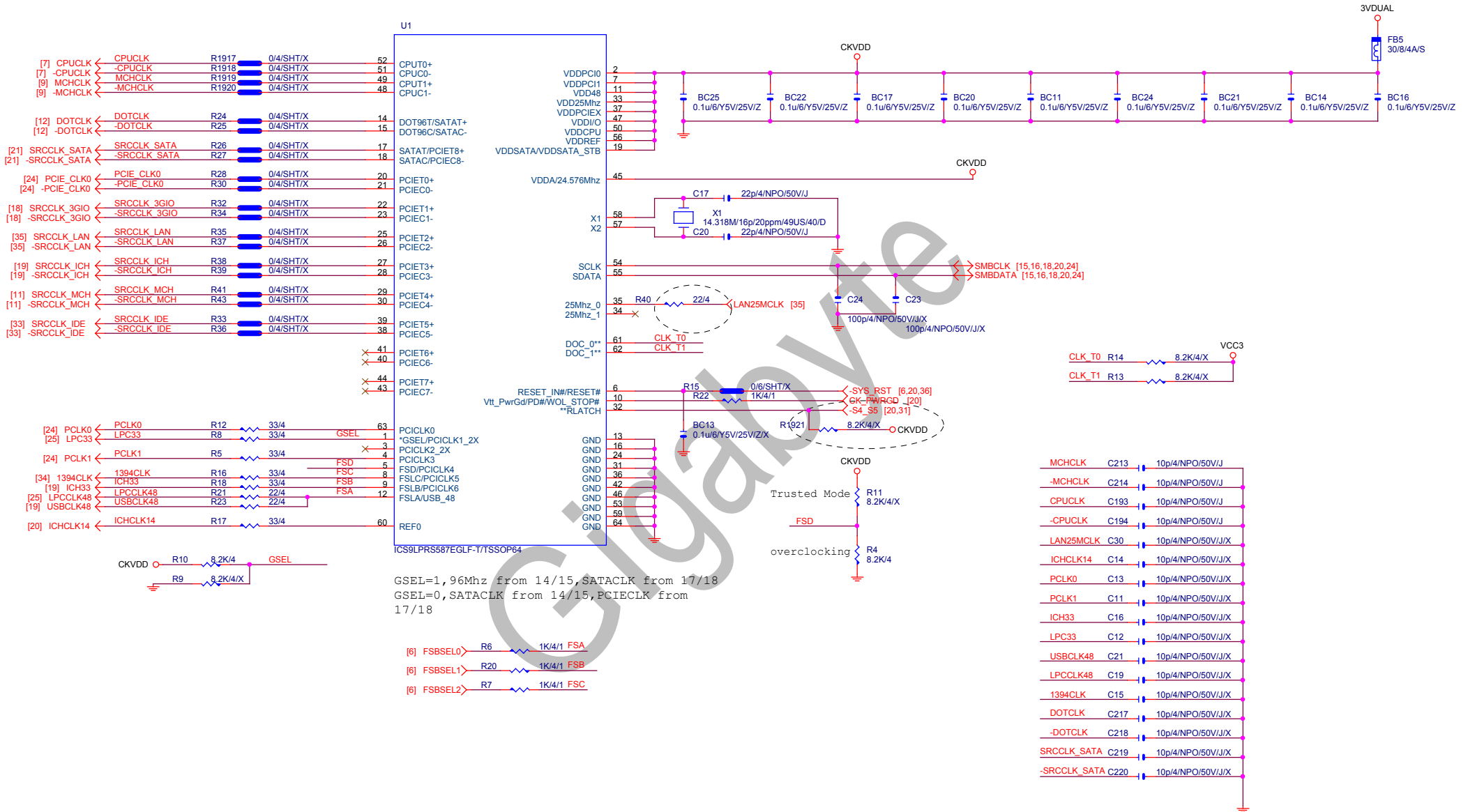





**IT8712F LPC I/O**

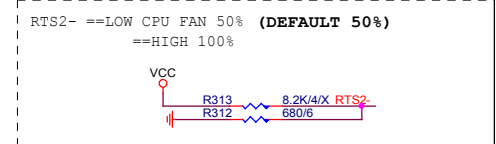
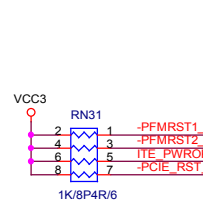
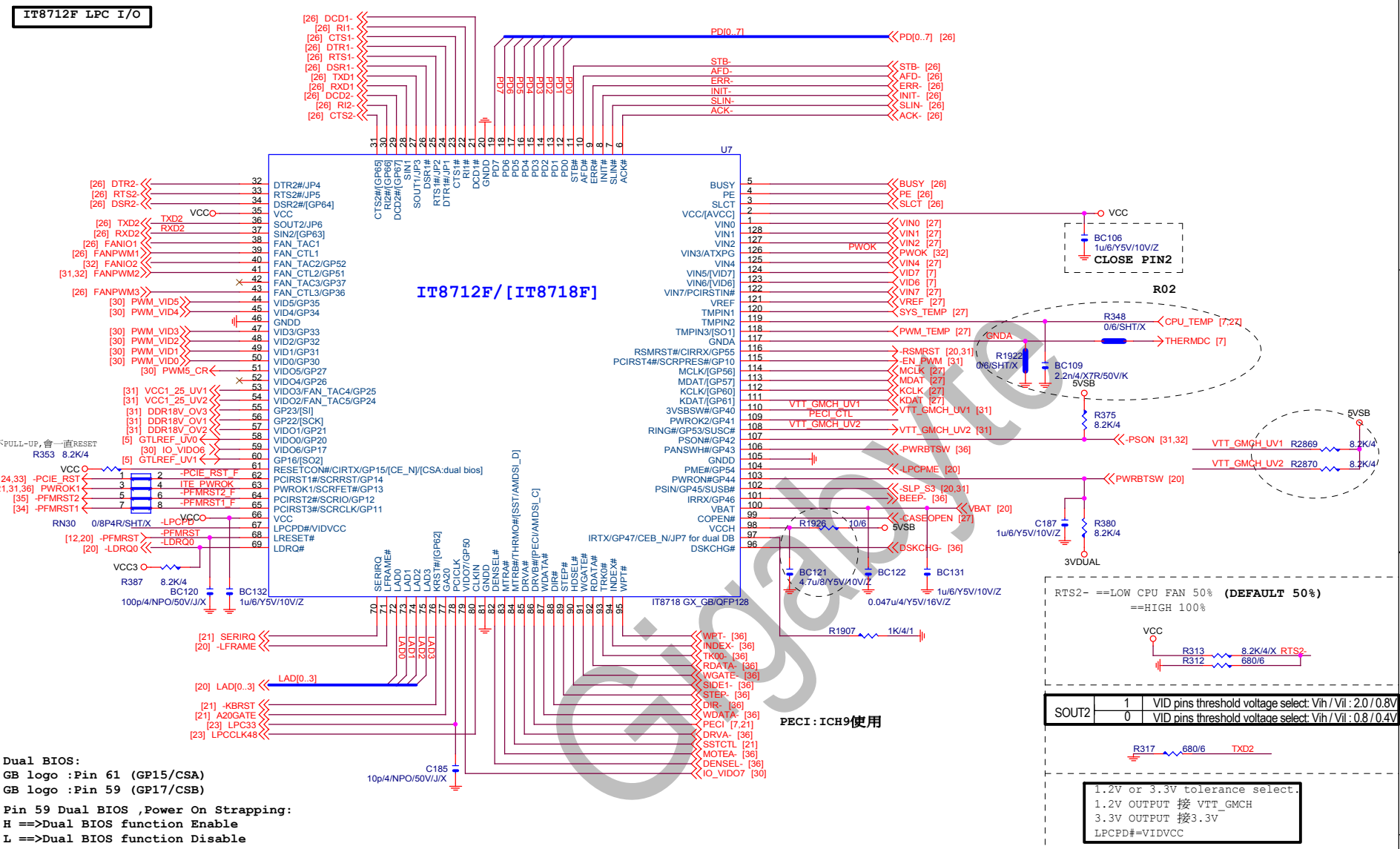

SOUT2	1	VID pins threshold voltage select: Vih / Vil : 2.0 / 0.8V
	0	VID pins threshold voltage select: Vih / Vil : 0.8 / 0.4V

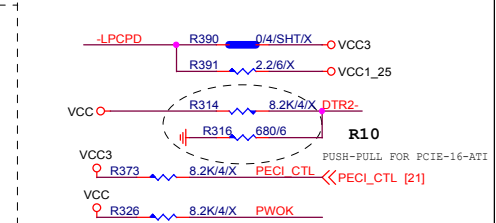
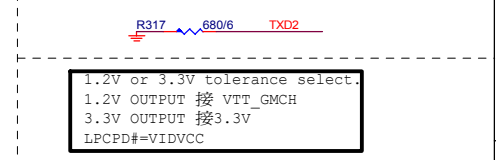

**COMA**

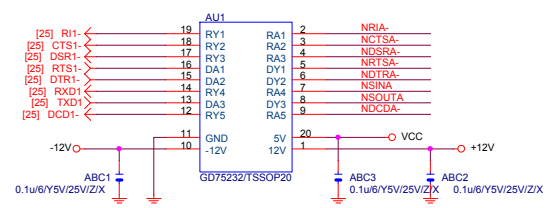

**COM RI**

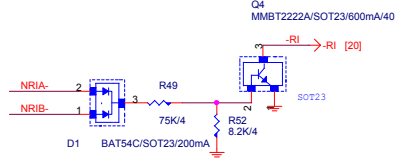

**EXTERNAL COMA**

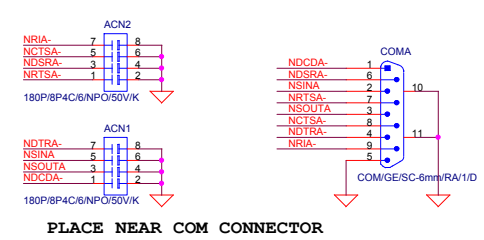

**COMB**

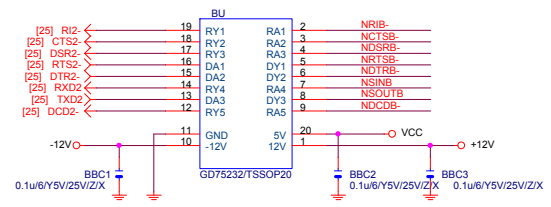

**INTERNAL COMB**

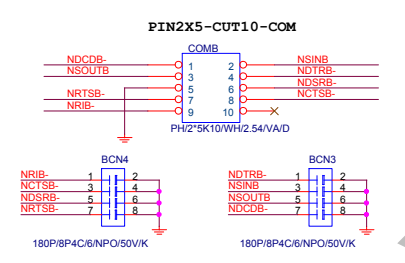

**LPT PORT**

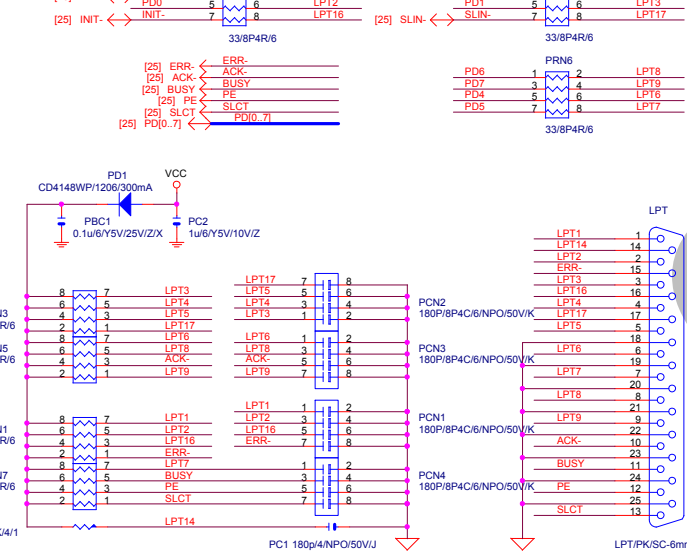

**-PROHOT**

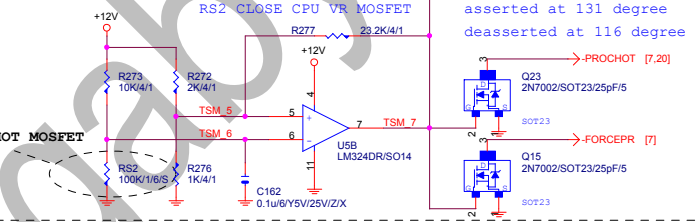

**CPU SMART FAN**

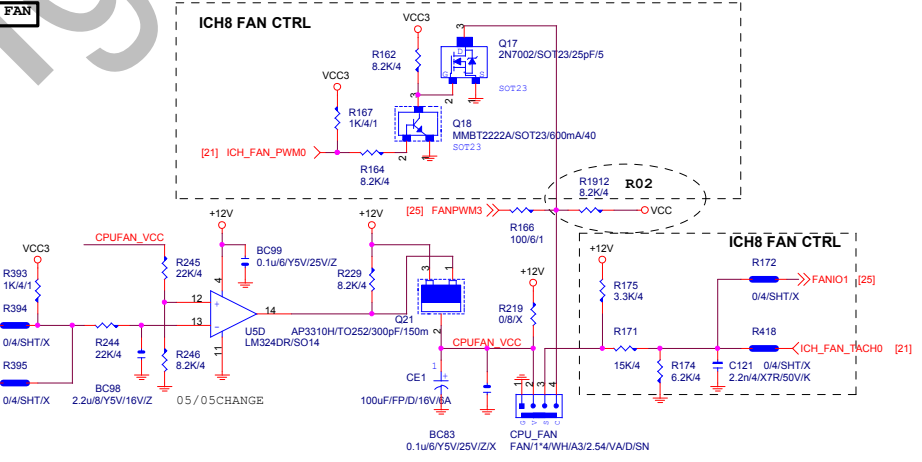

**TEMP H/W MONITOR**

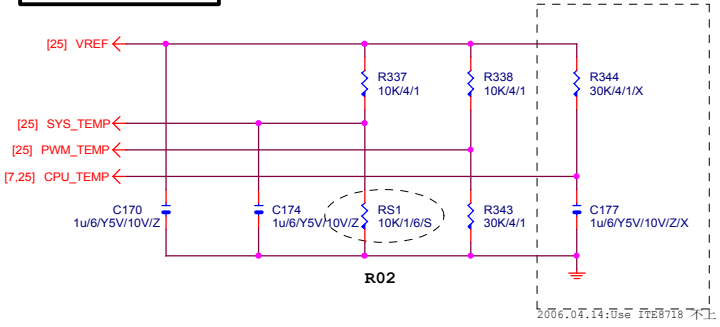

**CASE OPEN**

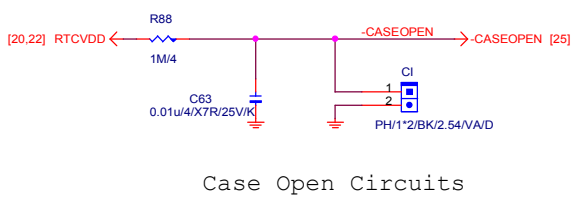

**KB/MS**

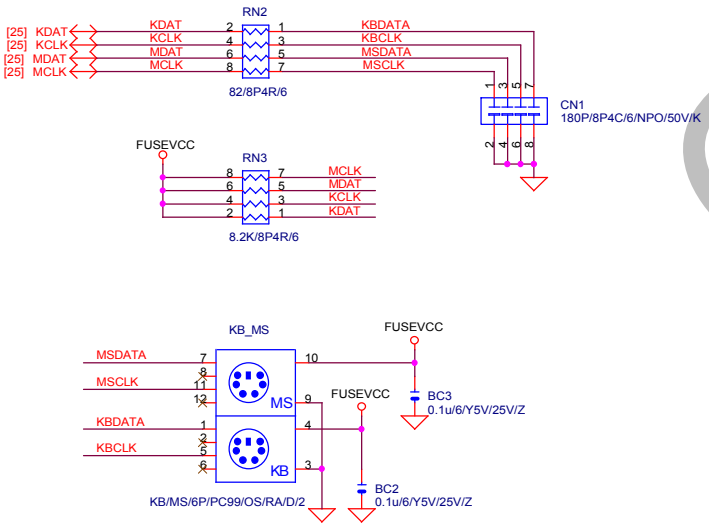

**VOLTAGE-- H/W MONITOR**

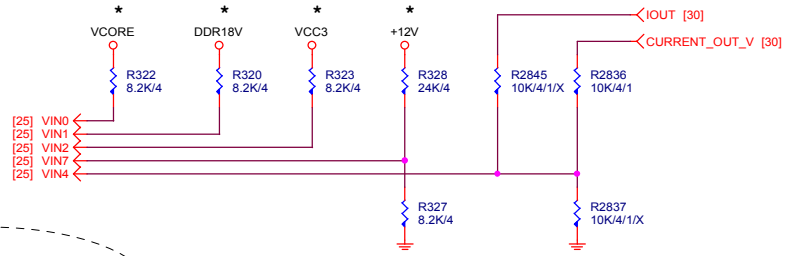

**SPI BIOS**

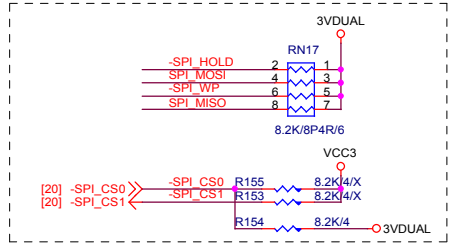
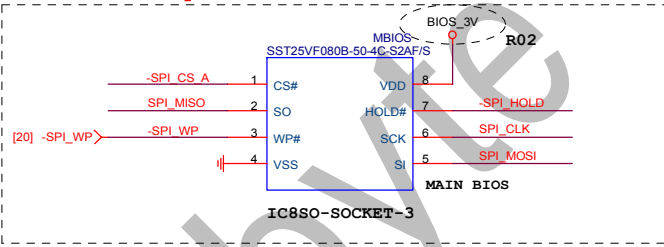
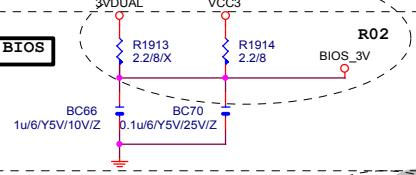

**FOR ICH BIOS**

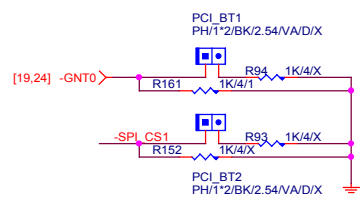
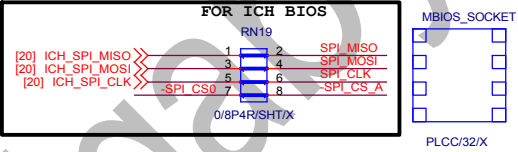

BOOT DEVICE	GNT0	CS1
SPI	0	1
PCI	1	0
FWH	1	1

	ALC889A	ALC999
GPI00	LOW	N/A
GPI01	LOW	LOW

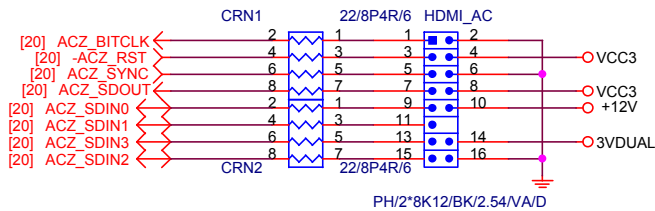
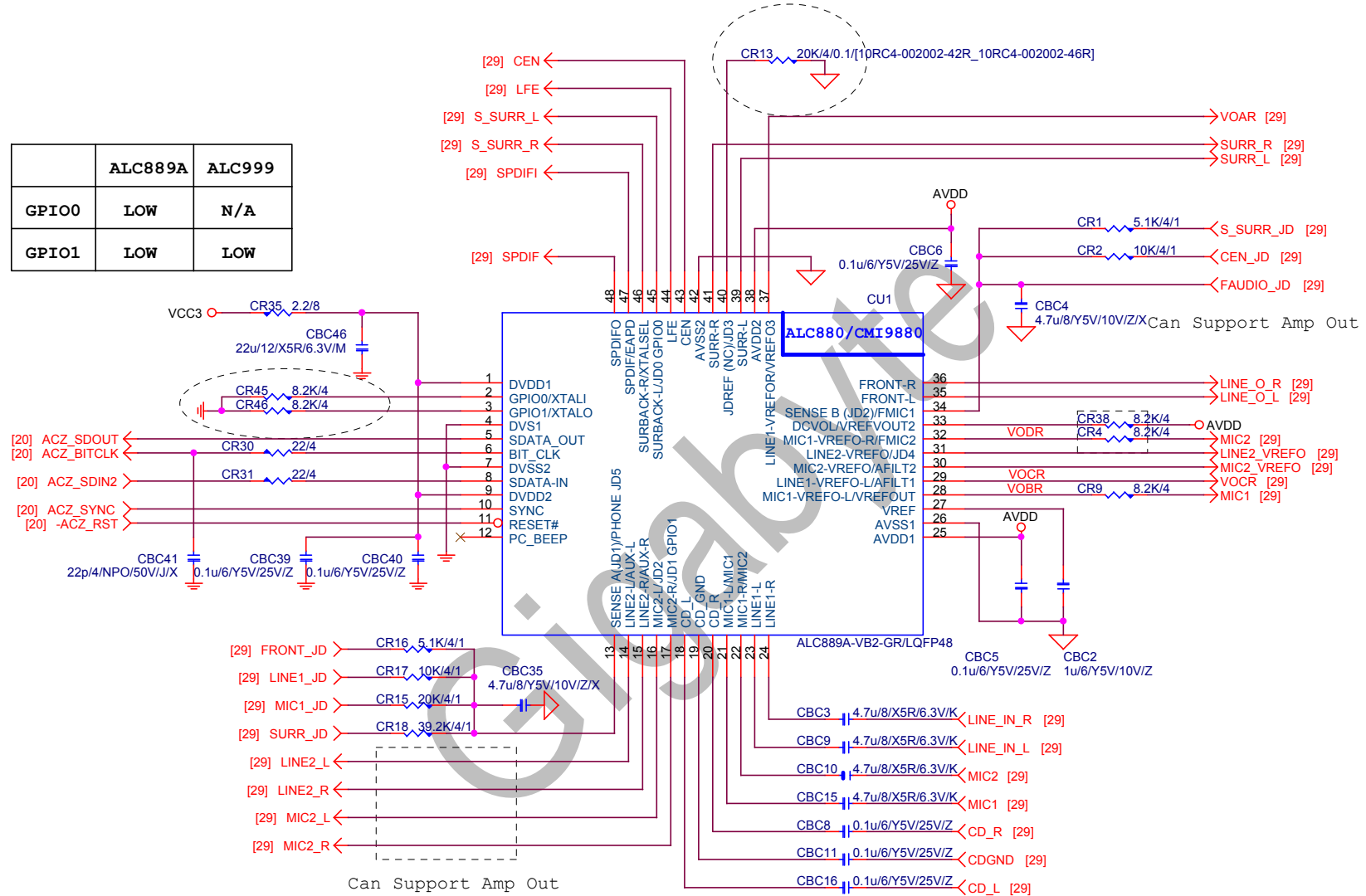

**Gigabyte Technology**

**AZALIA ALC889**

**G33M-DS2R**

Rev **1.01**

Date: Tuesday, April 03, 2007      Sheet 28 of 36

**CODEC POWER/EMI PAD**

**CO-LAYOUT**

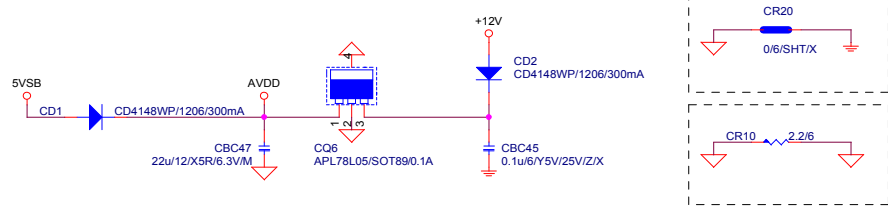

**CD IN**

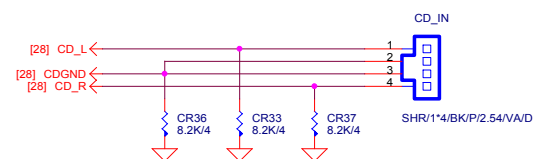

**SPDIF**

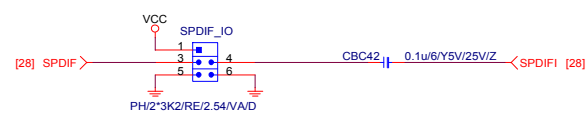

**AZALIA JACK**

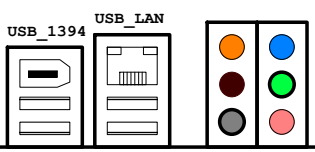

**BTX AZALIA CONNECTOR**

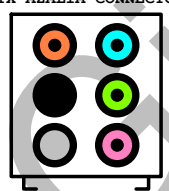

3RP/26P/OR, BK, GY, BU, GE, PK/RA/D/1/B  
VISTA規範: REAR-->BLK, CEN/SUB-->ORG

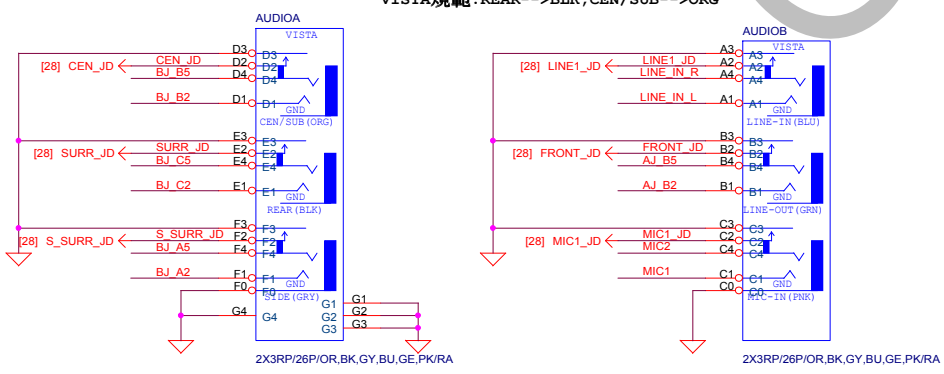

**LINE-OUT**

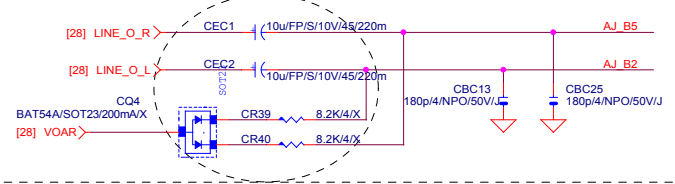

**LINE-IN**

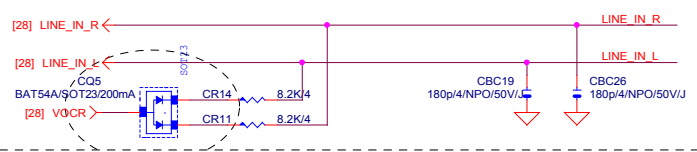

**MIC-IN**

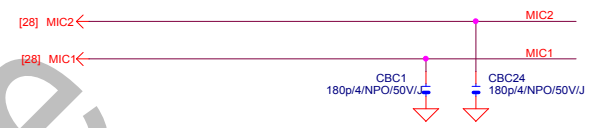

**SURROUND**

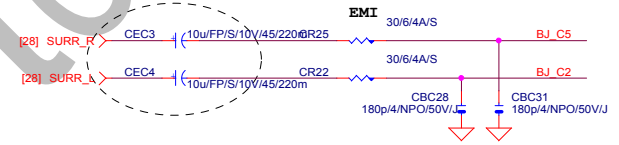

**CEN/LFE**

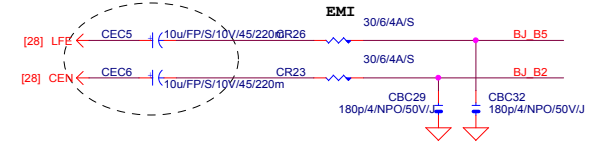

**SURRBACK**

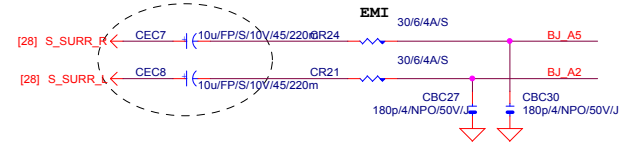

**AZALIA FRONT PANEL**

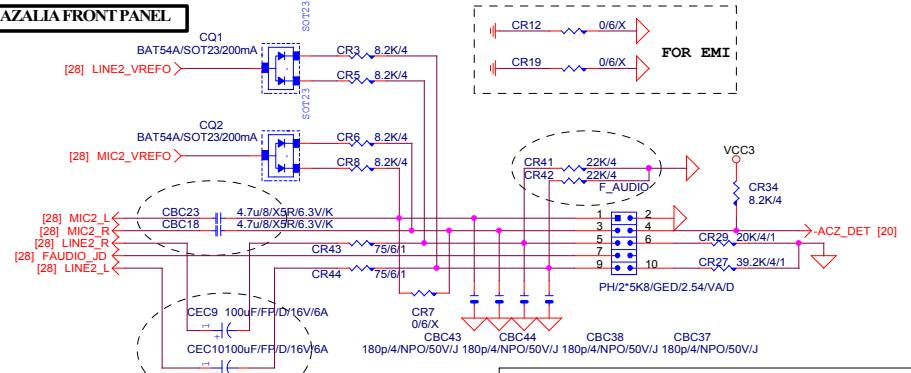

<b>Gigabyte Technology</b>		
<b>AUDIO JACK</b>		
<b>G33M-DS2R</b>		
Title	Document Number	Rev
Size	Custom	1.01
Date: Tuesday, April 03, 2007	Sheet 29	of 36

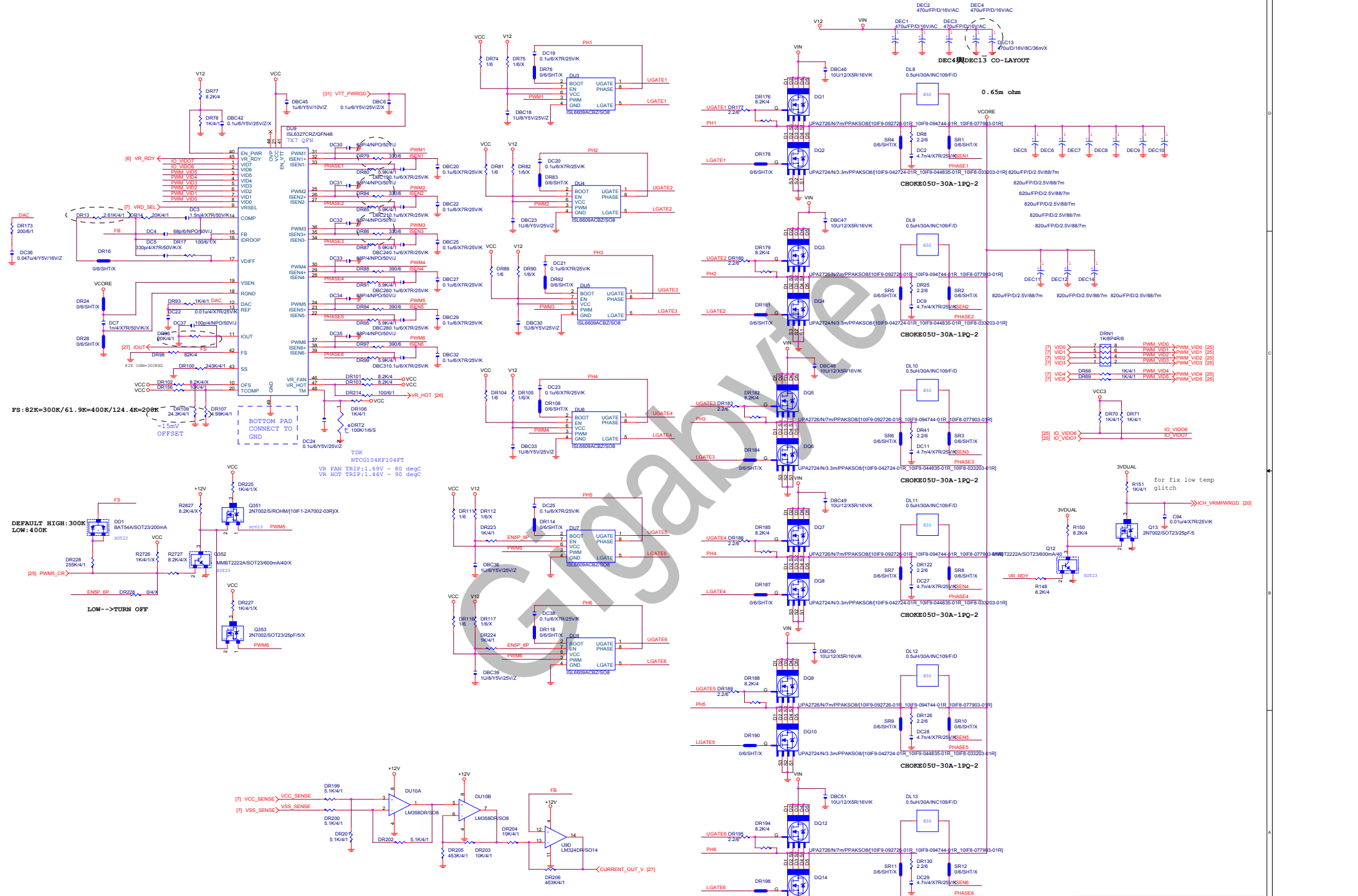

FS: 82K=300K/61.9K=400K/124.4K=200K

DEFAULT HIGH: 300K  
LOW: 400K

LOW --> TURN OFF

[7] VCC\_SENSE  
[7] VSS\_SENSE

[7] VCC\_SENSE  
[7] VSS\_SENSE

[7] VCC\_SENSE  
[7] VSS\_SENSE

[7] VCC\_SENSE  
[7] VSS\_SENSE

[7] VCC\_SENSE  
[7] VSS\_SENSE



# ATX POWER CONNECTOR

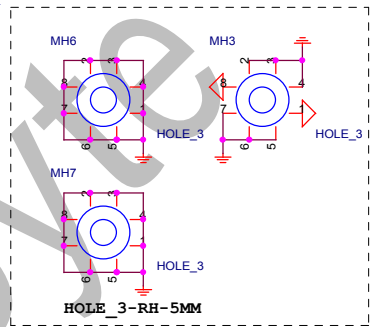
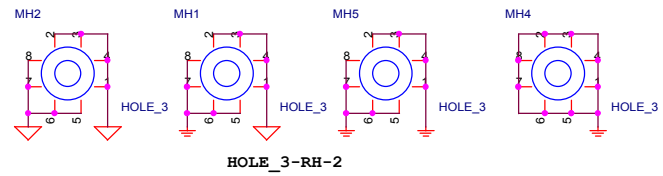
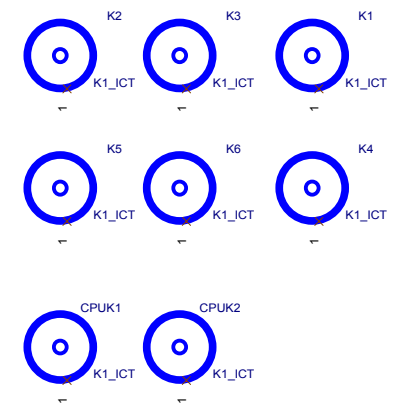
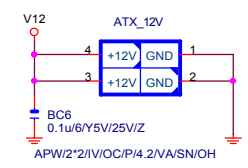
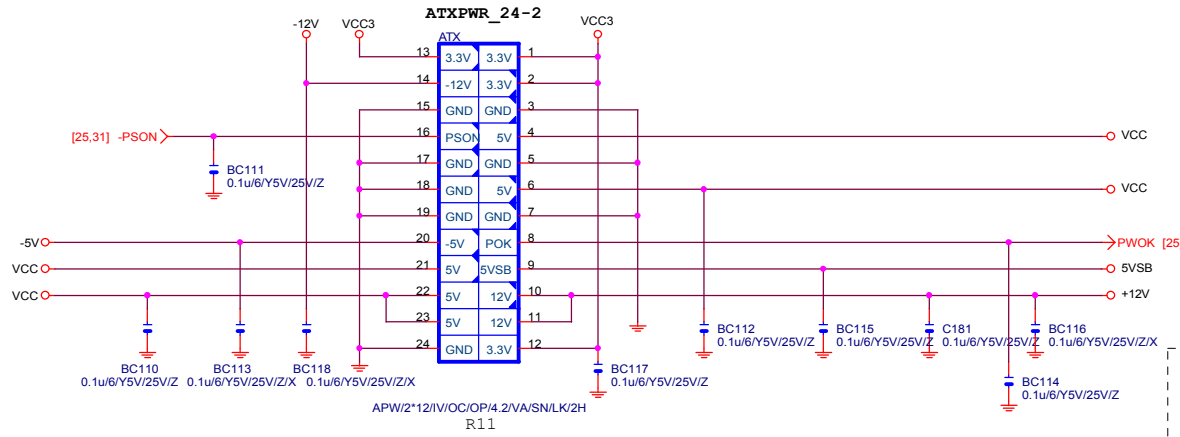

## SYS SMART FAN

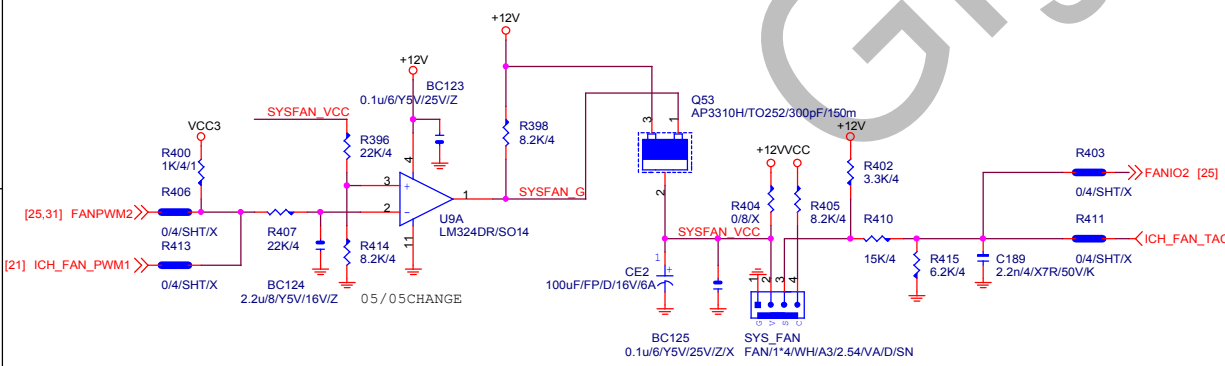

- Position (1635,-7765) , 0.01uF cap DDR18V to GND
- Position (1980,-7715) , 0.01uF cap DDR18V to VCC3
- Position (2195,-7795) , 0.01uF cap DDR18V to VCC3
- Position (5405,-430) , 0.01uF cap FuseVcc to GND
- Position (7945,-1345) , 0.01uF cap 5VDual to GND
- Position (4725,-8935) , 0.01uF cap 5Vdual to GND
- Position (-245,-1425) , 0.01uF cap 3Vdual to GND
- Position (-680,-705) , 0.01uF cap 3Vdual to GND
- Position (-845,-3750) , 0.01uF cap BUSVCC0 to GND
- Position (-175,-1325) , 0.01uF cap BUSVCC0 to GND

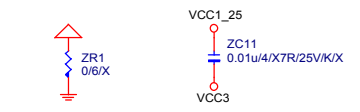
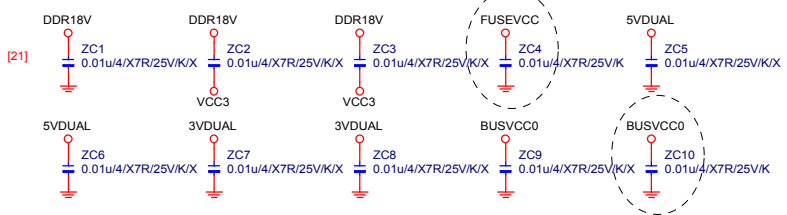

<b>Gigabyte Technology</b>		
<b>ATX PWR/SYS FAN</b>		
<b>G33M-DS2R</b>		Rev <b>1.01</b>
Date:	Tuesday, April 03, 2007	Sheet 32 of 36



JMicron 1P PATA

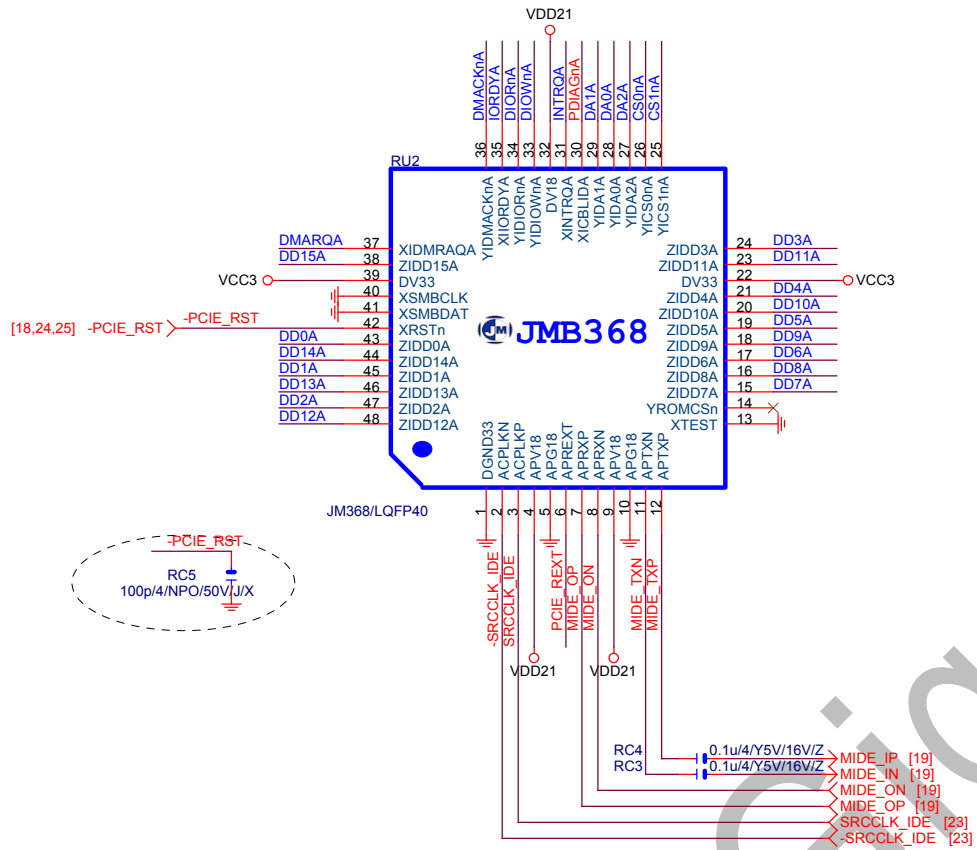

3.3V to 2.1V Voltage Regulator

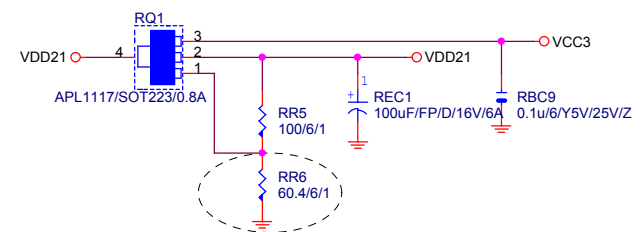

JMicron suggest JMB368 to 2.1V

Active LED

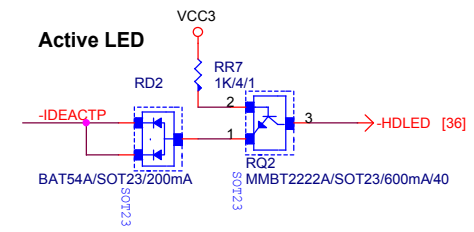

Near to PIN

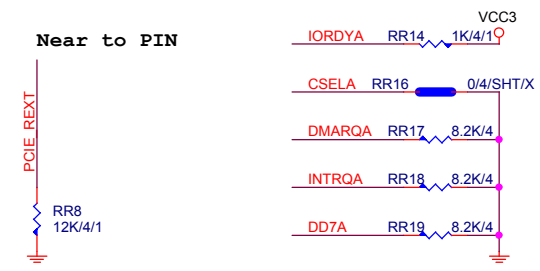

IDE Connector

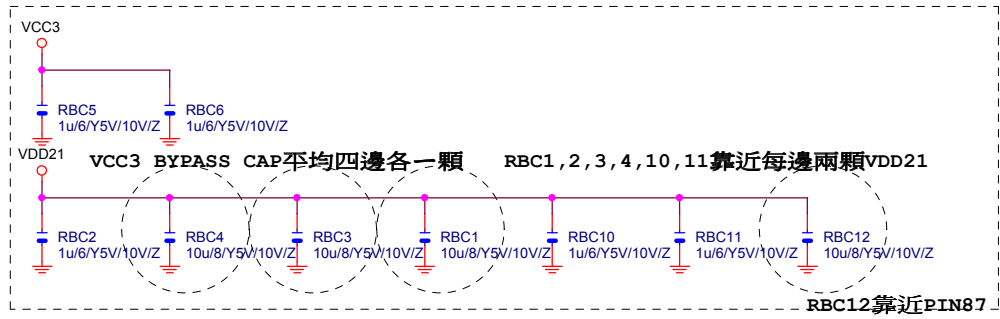
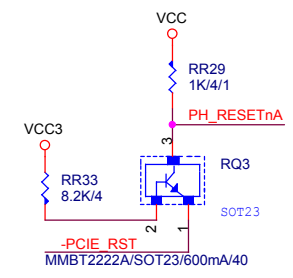
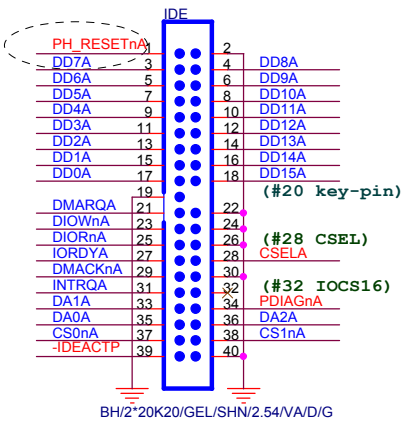

Gigabyte Technology		
Title JMicron 1P PATA		
Size	Document Number	Rev
	G33M-DS2R	1.01
Date:	Tuesday, April 03, 2007	Sheet 33 of 36

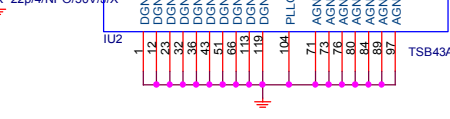
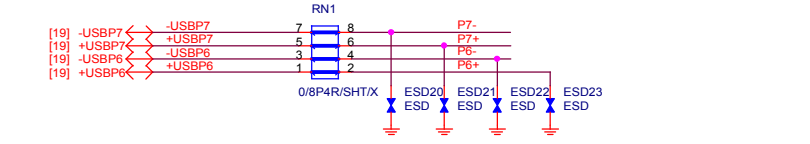
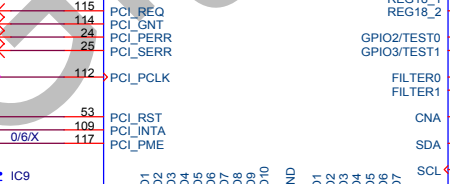
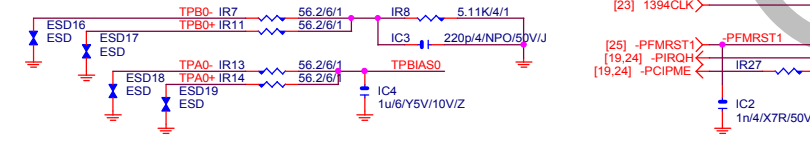
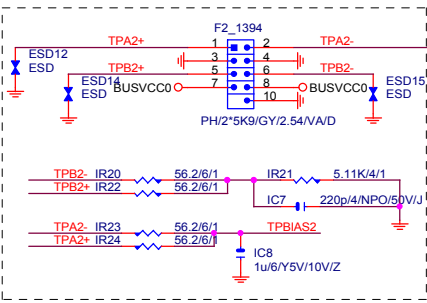
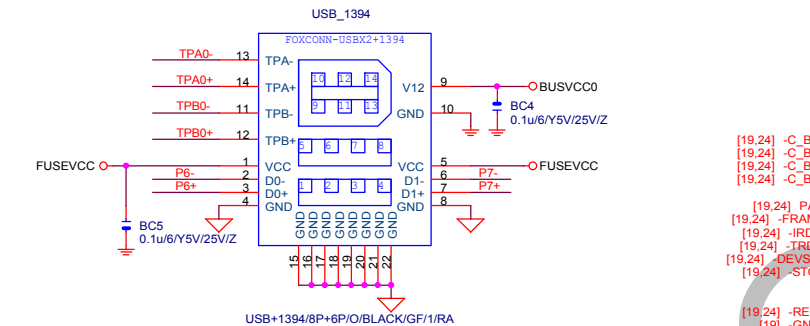
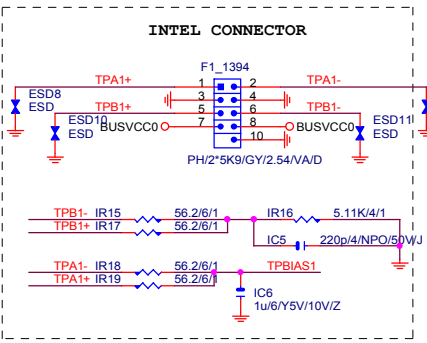
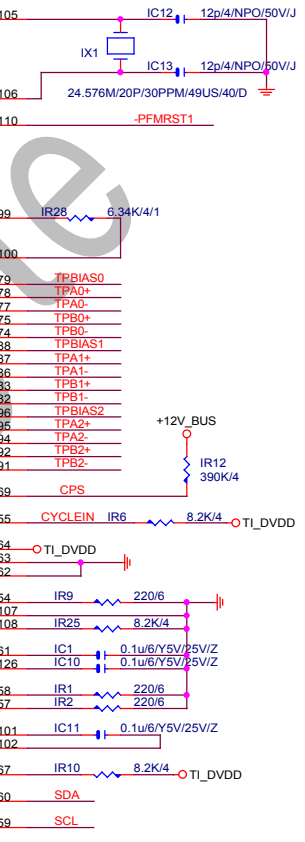
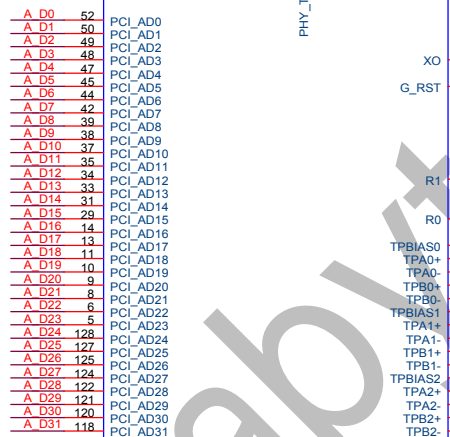
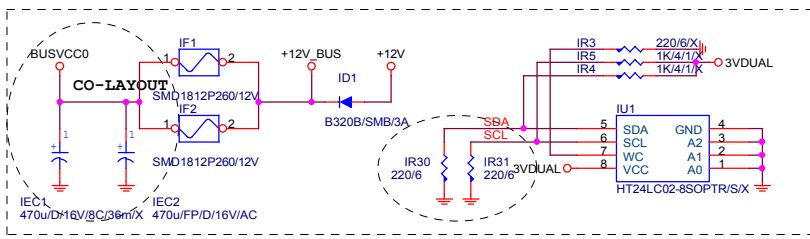
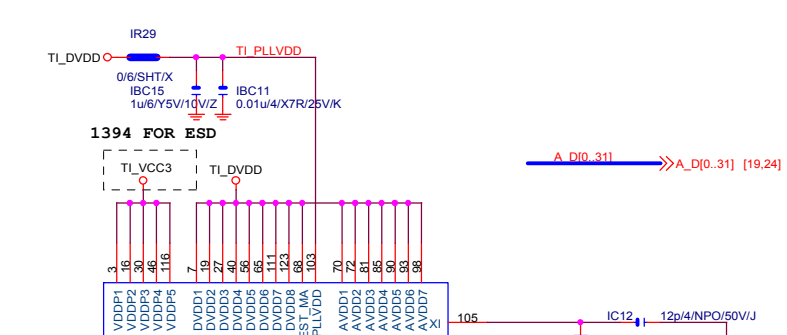
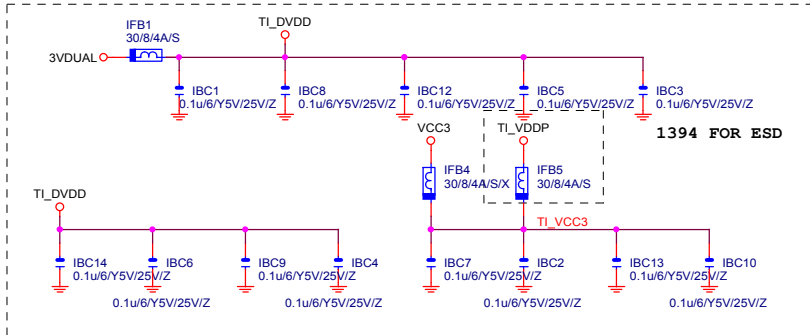

**PCIe-1G LAN**

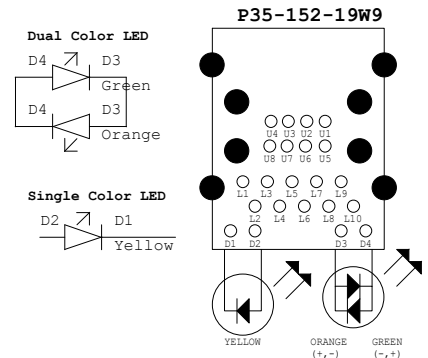
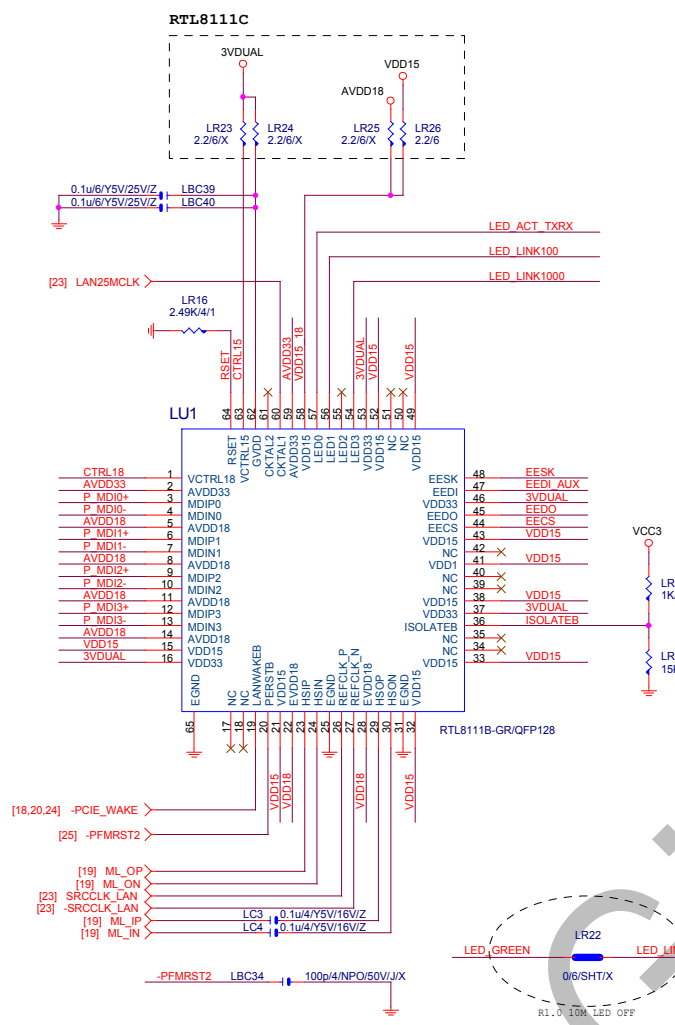

**Power domain chart**

	RTL8111B / RTL8101E	RTL8111C
AVDD33	3.3V	3.3V
AVDD18	1.8V	1.2V
EVDD18	1.8V	1.2V
DVDD15	1.5V	1.2V

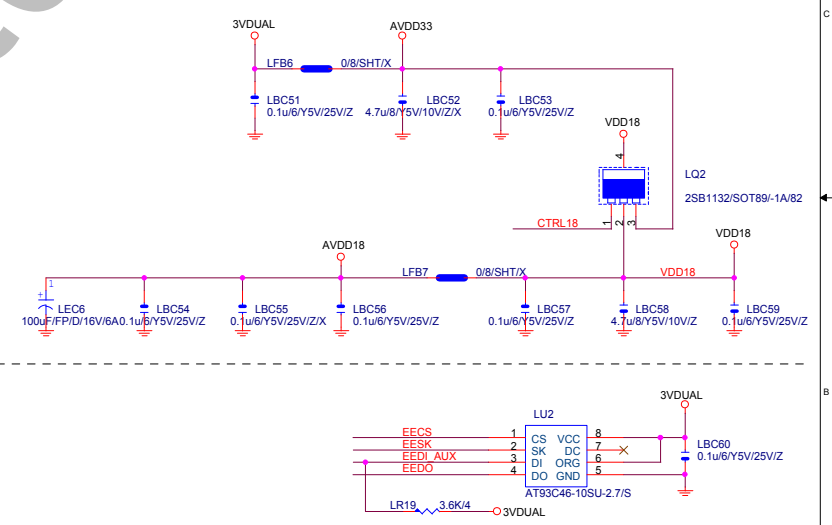
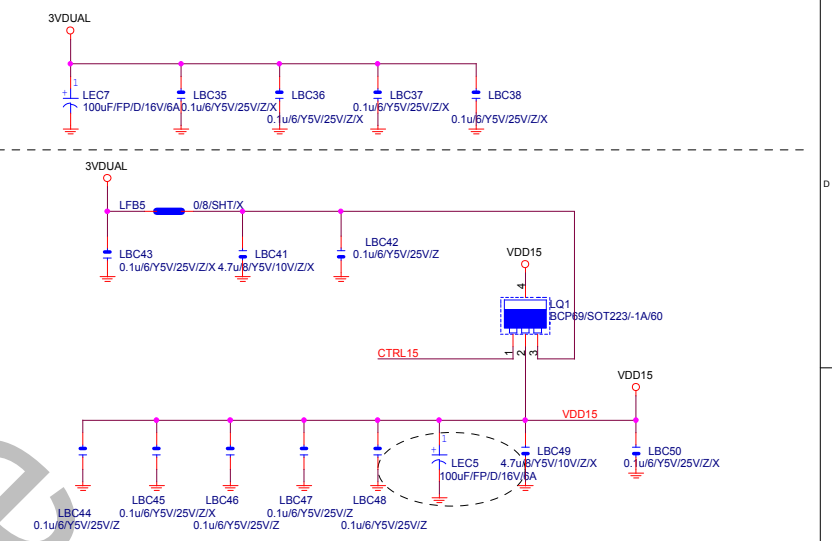

**USB LAN CONNECTOR**

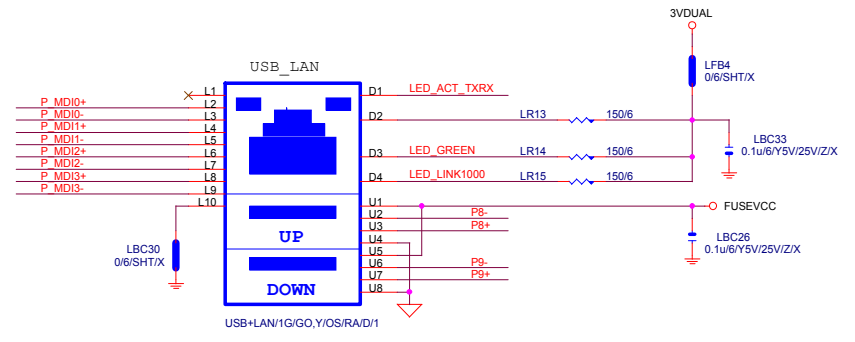

**USB LAN**

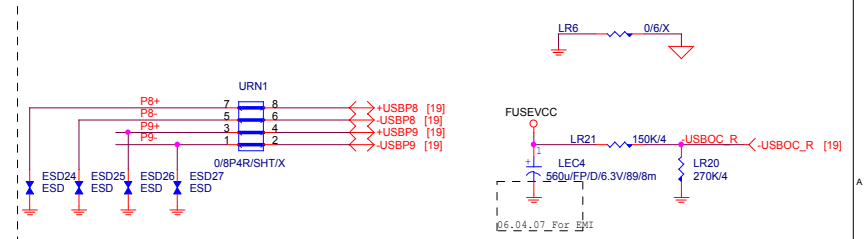

**Gigabyte Technology**

Title: **REALTEK RTL8111B/C**

Size Custom: Document Number **G33M-DS2R** Rev **1.01**

Date: Tuesday, April 03, 2007 Sheet 35 of 36

**FRONT USB1** 0,1,2,3,4,5,10,11-->EHCI#1  
6,7,8,9-->EHCI#2

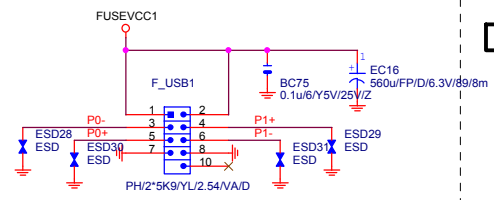
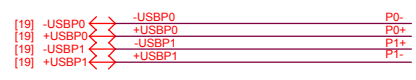

**FRONT USB2**

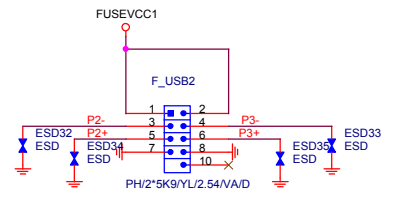
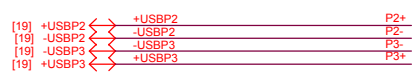

**FRONT USB3**

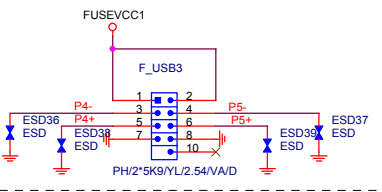

**FRONT USB4**

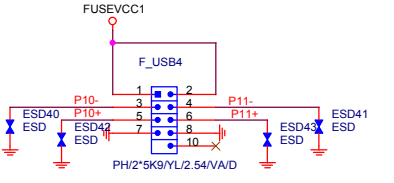
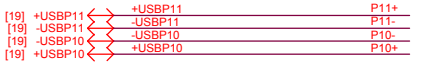

**USB DROP**

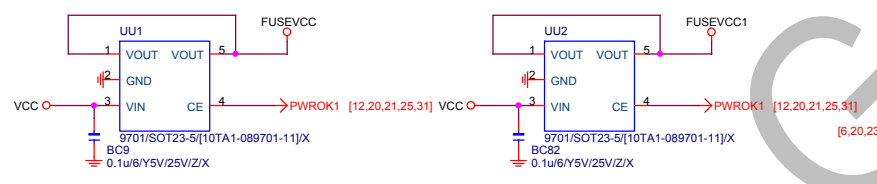

**FRONT USB OC1**

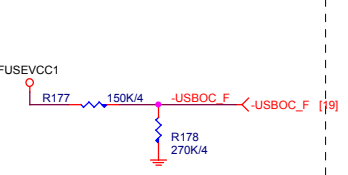

**USB POWER**

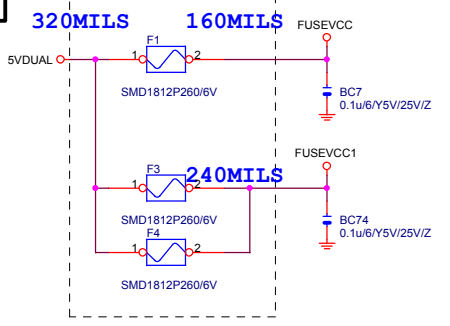

**FLOPPY**

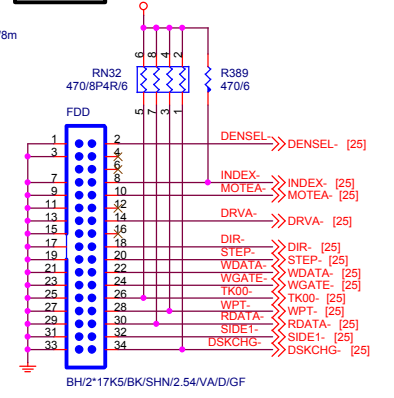

**SATA LED**

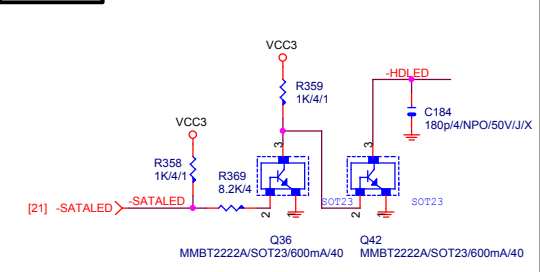

**BUZZER**

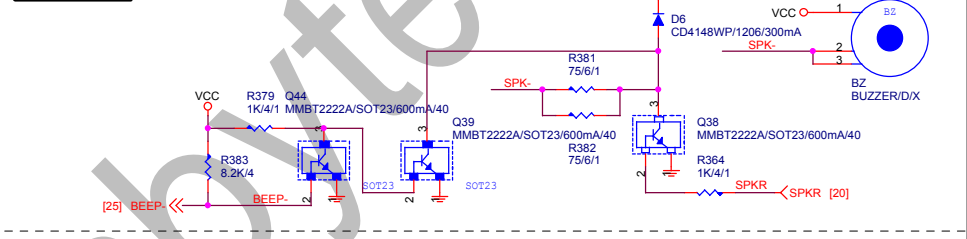

**INTEL FRONT PANEL**

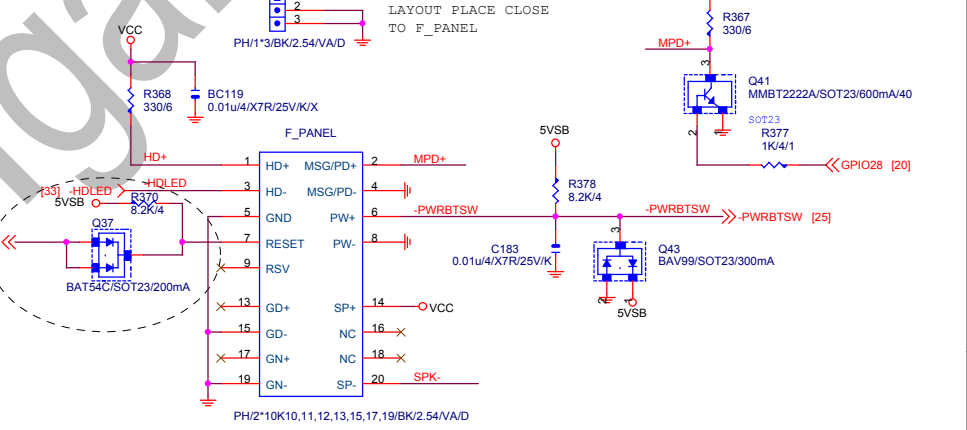

<b>Gigabyte Technology</b>			
Title <b>FP,F_USB,USB PWR,FDD,BZ</b>			
Size	Document Number	Rev	
Custom	<b>G33M-DS2R</b>	<b>1.01</b>	
Date:	Tuesday, April 03, 2007	Sheet	31 of 36