

SHEET

TITLE

01	COVER SHEET
02	BLOCK DIAGRAM
03	BOM & PCB MODIFY HISTORY
04	P4 LGA775 A
05	P4 LGA775 B,D
06	P4 LGA775 C
07	P4 LGA775 E,F,G,H
08	G31 HOST
09	G31 DDRII
10	G31 PCI E, DMI
11	G31 VGA
12	G31 GND
13	G31 PWR
14	PCI EXPRESS*16 SLOT
15	DDRII CHANNEL A
16	DDRII CHANNEL B
17	DDRII TERMINATION
18	ICH7 PCI, USB, DMI, LAN
19	ICH7 IDE, GPIO, SATA, CTRL
20	ICH7 VCC, GND
21	CK505 CLOCK.
22	PCI SLOT 1,2,PCIE*1
23	IDE/FLOPPY
24	ITE 8718 GB/GX
25	COM LPT
26	CI, HWM, KB/MS, BIOS
27	ALC888

SHEET

TITLE

28	REAR AUDIO JACK
29	DISCRETE POWER
30	VCORE PWM ISL6334
31	ATX, OTHERS POWER
32	FRONT PANEL
33	REALTEK RTL8111C/8101E

<b>Gigabyte Technology</b>			
Title <b>Cover Sheet</b>			
Size	Document Number	EG31M-S2	Rev
Custom			1.02
Date:	Thursday, April 10, 2008	Sheet	1 of 33

# BLOCK DIAGRAM

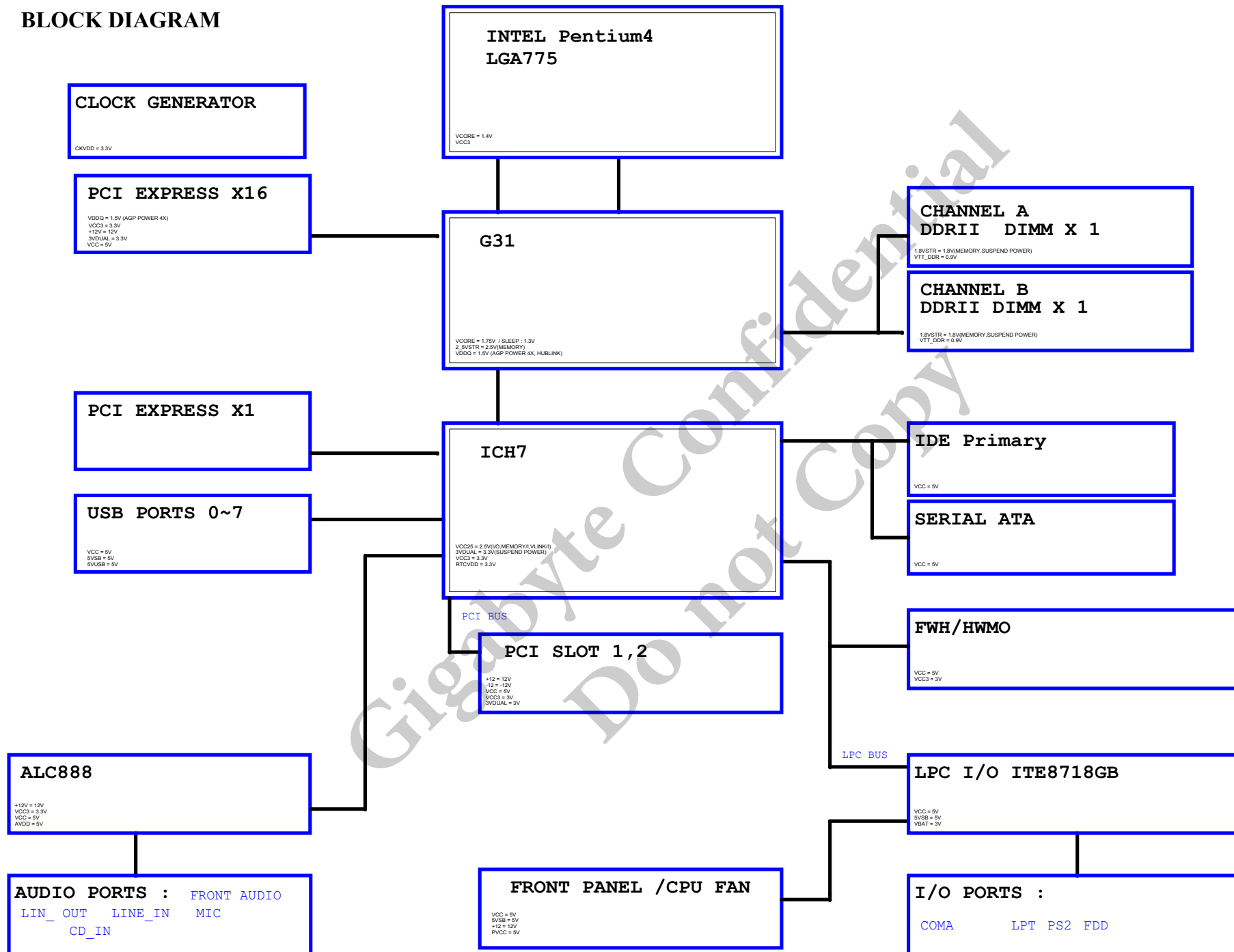



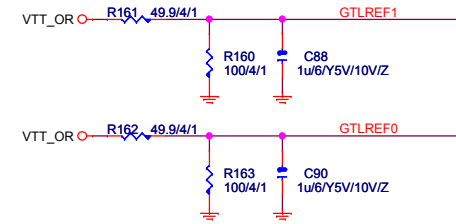
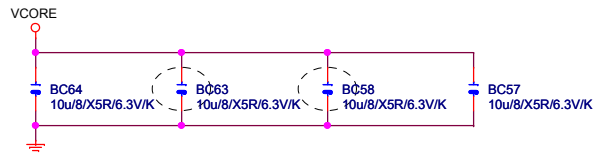
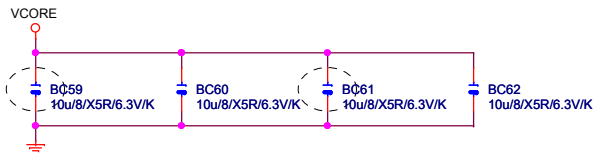

中間値 0.9V

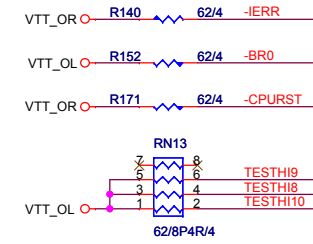

LGA775-39

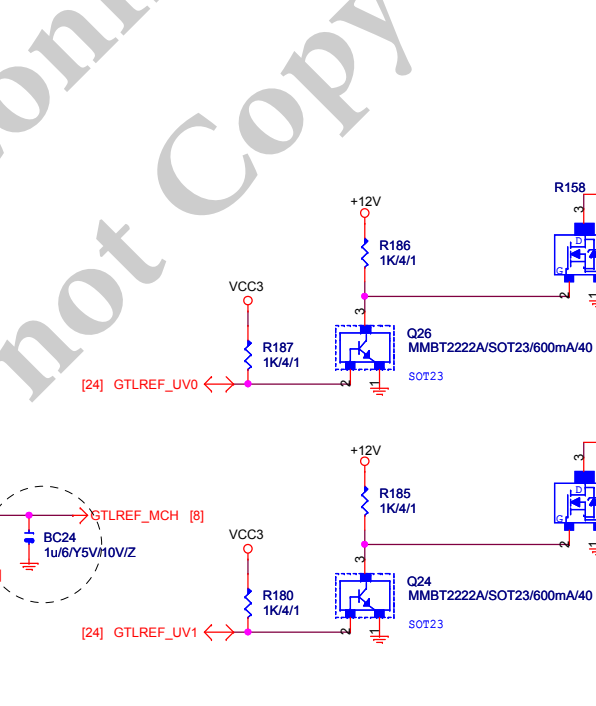
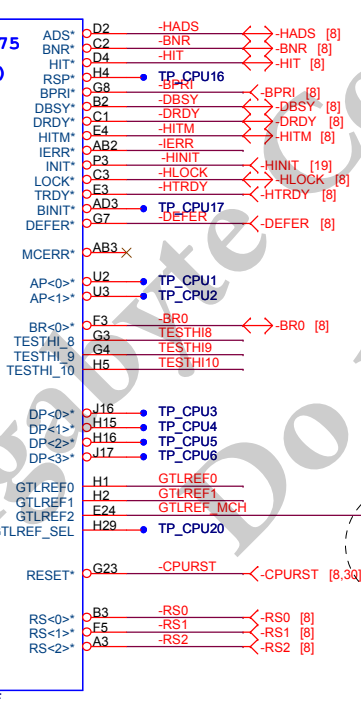
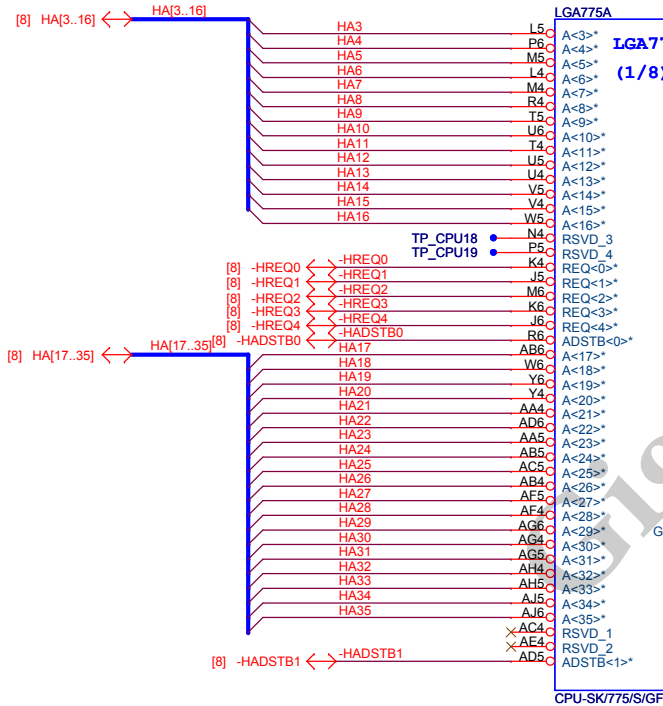

<b>Gigabyte Technology</b>		
Title		
<b>P4_LGA775-A</b>		
Size	Document Number	Rev
3	<b>EG31M-S2</b>	<b>1.02</b>
Date:	Thursday, April 10, 2008	Sheet 4 of 33

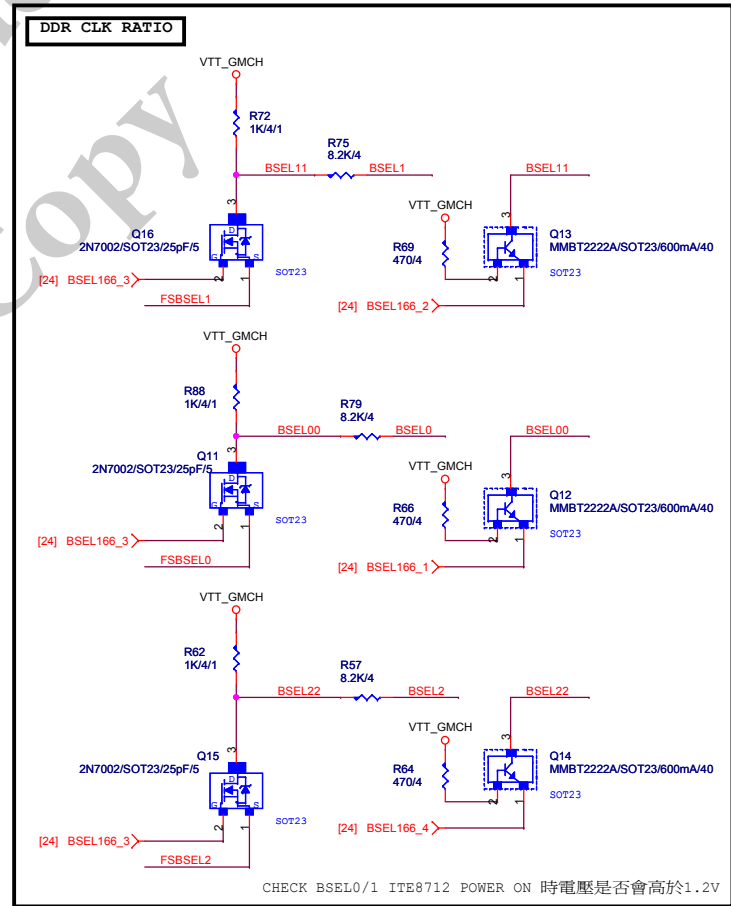
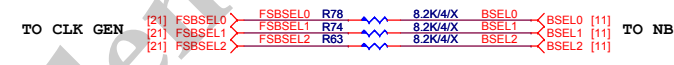
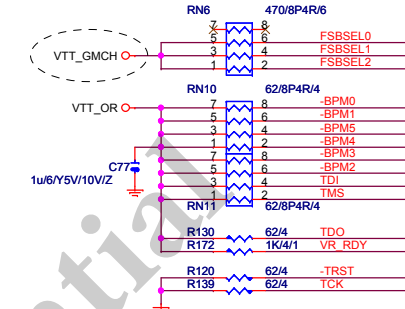
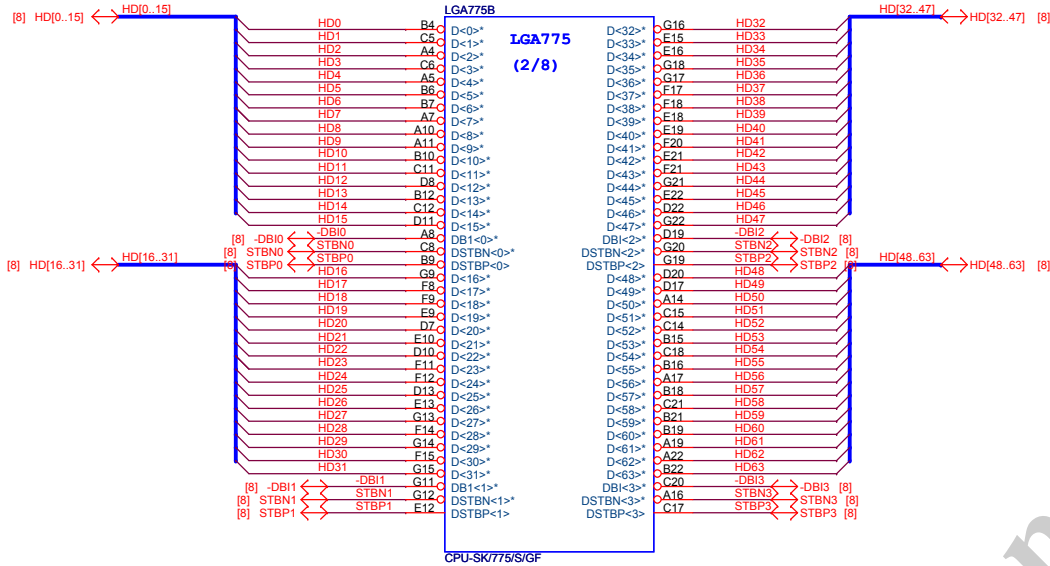

CHECK BSEL0/1 ITE8712 POWER ON 時電壓是否會高於1.2V

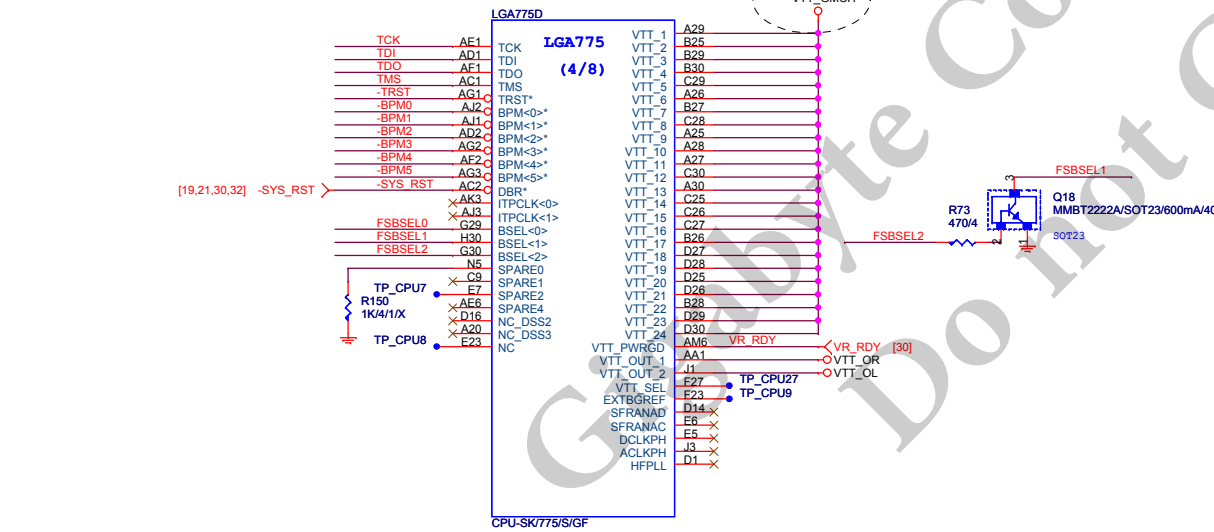

**CPU**

NA	FSB	FSA	Clock
FSBSEL3	FSBSEL1	FSBSEL0	Clock
1	0	1	100MHz
0	0	1	133MHz
0	1	1	166MHz
0	1	0	200MHz
0	0	0	266MHz

FSA	FSB	FSC	Clock
FSBSEL0	FSBSEL1	FSBSEL2	Clock
1	0	1	100MHz
1	0	0	133MHz
0	1	0	200MHz
0	0	1	333MHz

400/533  
400/533/667/800  
533/667/800/1066  
667/800

**Gigabyte Technology**

Title: **P4\_LGA775-B,D**

Size Custom: Document Number **EG31M-S2** Rev **1.02**

Date: Thursday, April 10, 2008 Sheet 5 of 33

**Note:**  
VCCA & VCOREPLL  
define doesn't same as  
old P4 design kit

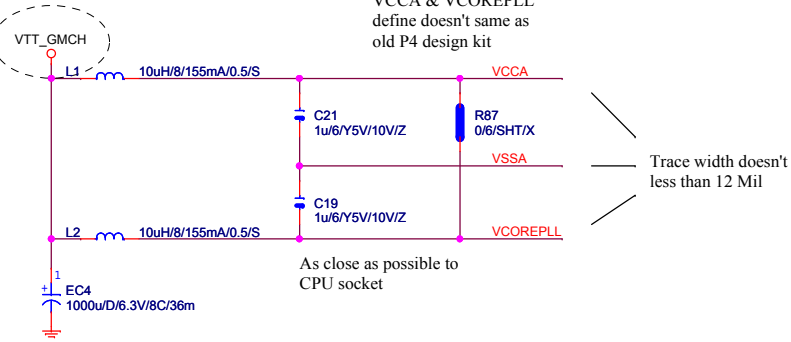

Place outside of CPU socket

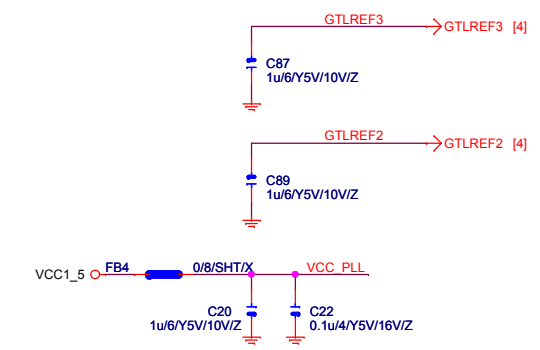
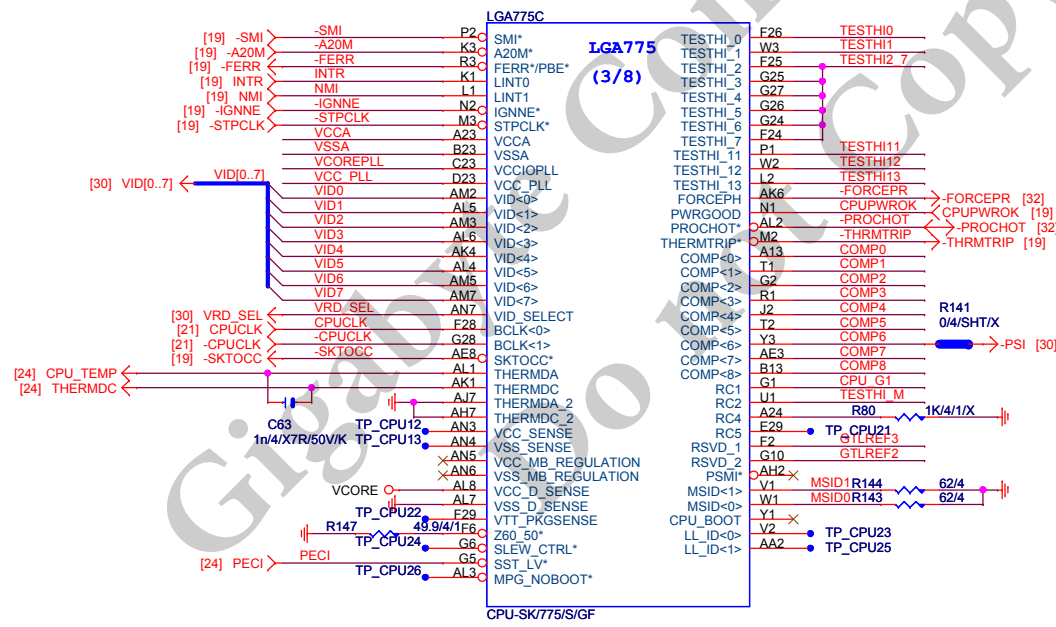
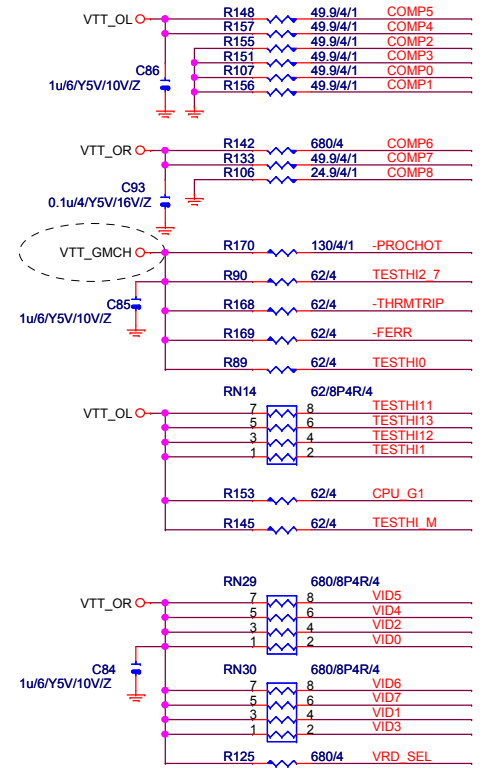

<b>Gigabyte Technology</b>		
<b>P4_LGA775-C</b>		
Size	Document Number	Rev
B	<b>EG31M-S2</b>	<b>1.02</b>
Date:	Thursday, April 10, 2008	Sheet 6 of 33

PECI: Platform Environment Control Interface

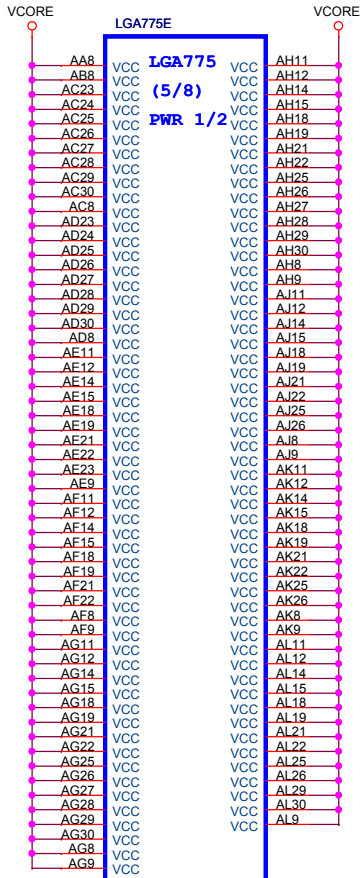

CPU-SK/775/S/GF

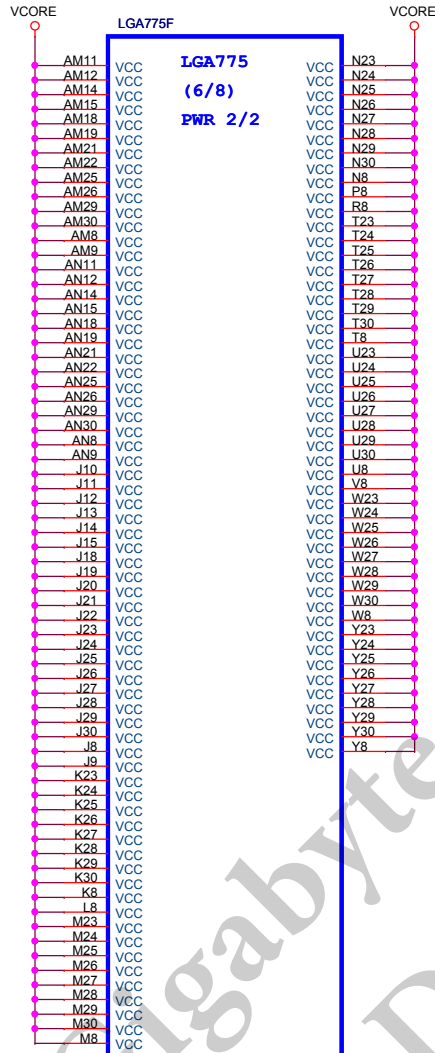

CPU-SK/775/S/GF

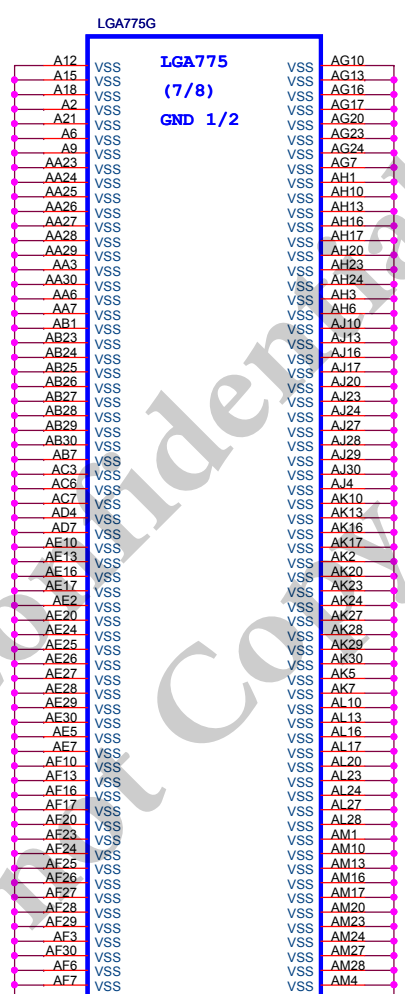

CPU-SK/775/S/GF

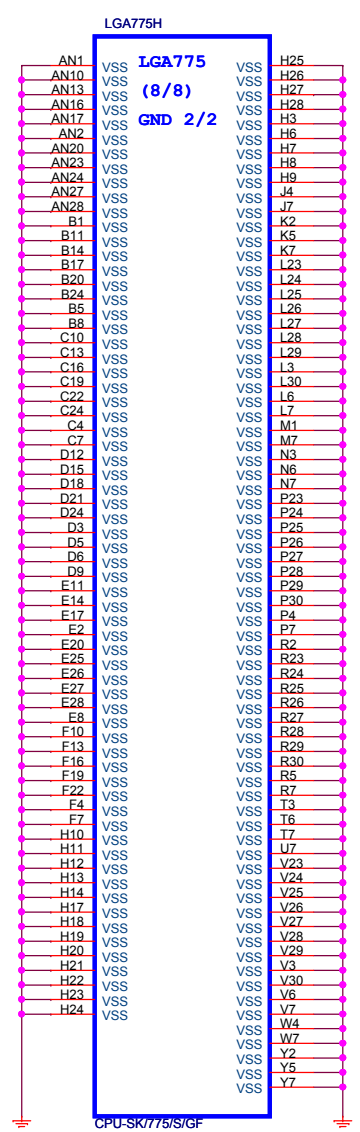

CPU-SK/775/S/GF

**Gigabyte Technology**

Title: **P4\_LGA775-E,F,G,H**

Size	Document Number	Rev
	<b>EG31M-S2</b>	<b>1.02</b>
Date:	Thursday, April 10, 2008	Sheet 7 of 33

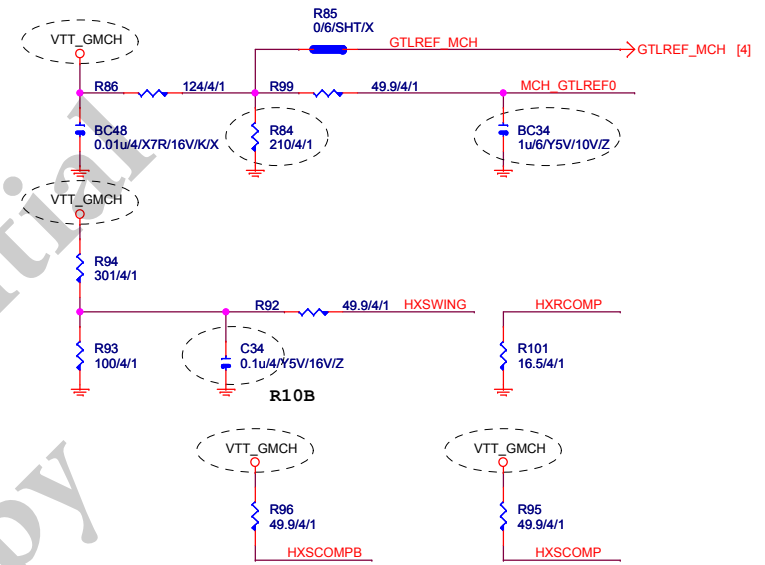
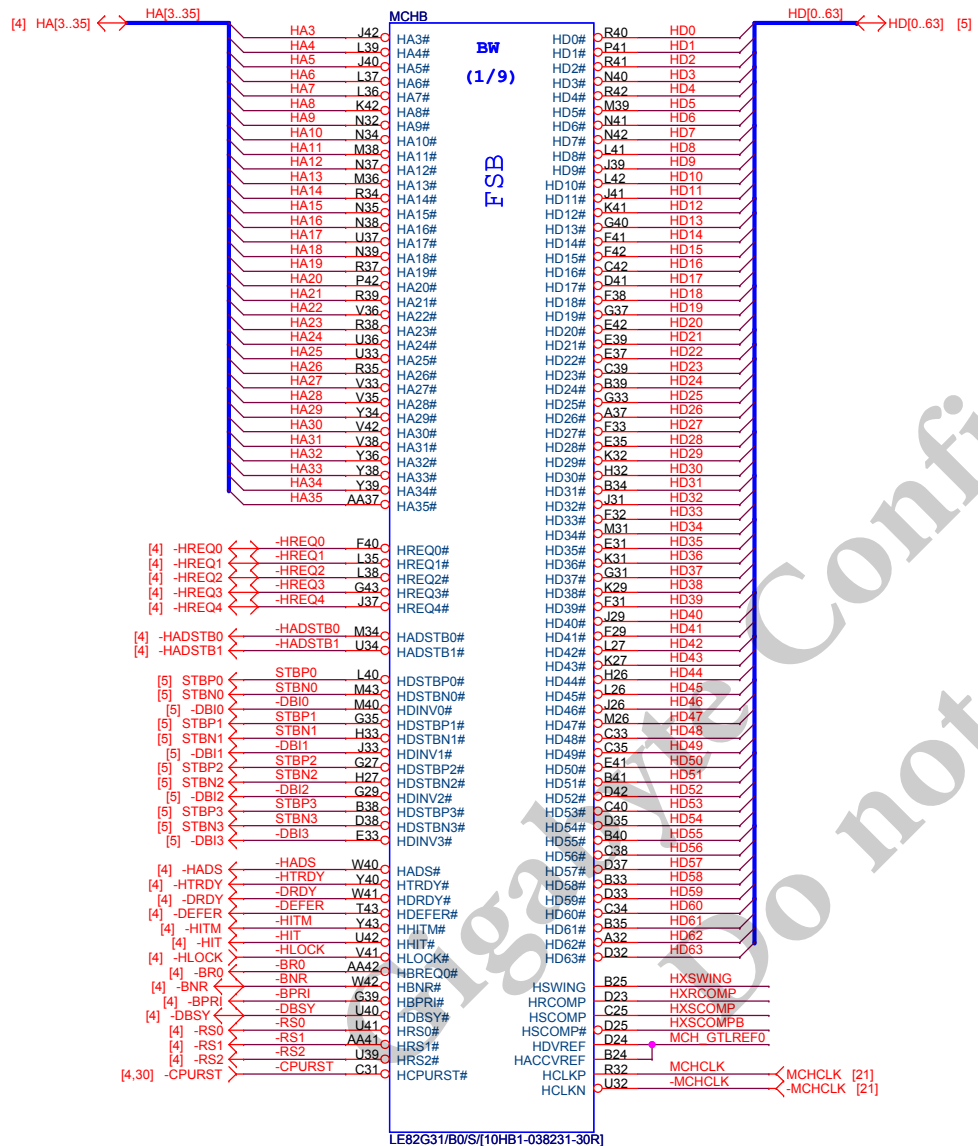

TOP層 COUPON REF VCC層  
 BOT層 COUPON REF GND層  
 不可同時接VCC+GND, 會造成測試不準



<b>Gigabyte Technology</b>		
Title <b>GMCH-HOST</b>		
Size	Document Number <b>EG31M-S2</b>	Rev <b>1.02</b>
Date: Thursday, April 10, 2008	Sheet 8	of 33



MCHC

Table listing MCHC components including SMA, SDQS, SDQ, and SCKE pins with their corresponding component IDs and values.

DDR\_0

RESERVED

AN21

MCHD

Table listing MCHD components including SMA, SDQS, SDQ, SCKE, and DCLK pins with their corresponding component IDs and values.

DDR\_1

RESERVED\_7

MCH\_VREF

SVREF

RESERVED\_8

RESERVED\_9

RESERVED\_10

RESERVED\_11

RESERVED\_12

RESERVED\_13

RESERVED\_14

RESERVED\_15

RESERVED\_16

RESERVED\_17

RESERVED\_18

RESERVED\_19

RESERVED\_20

RESERVED\_21

RESERVED\_22

RESERVED\_23

Table listing MCHD components including MODT, DQSB, and DQSB pins with their corresponding component IDs and values.

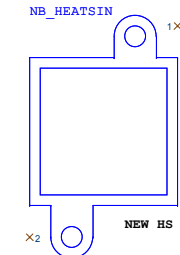
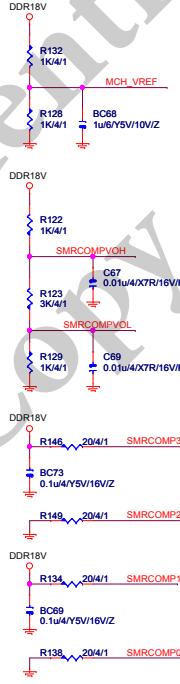

NB\_HS[12SP2-04F004-01R\_12SP2-04F004-02R\_12SP2-04F004-03R\_12SP2-04F004-04R]

LE82G31B0S[10HB1-038231-30R] CHANNEL A

LE82G31B0S[10HB1-038231-30R] CHANNEL B

Gigabyte Technology

Table with columns: Title (GMCH-DDRII), Document Number (EG31M-S2), Rev (1.02), Date (Thursday, April 10, 2008), Sheet (9 of 33).

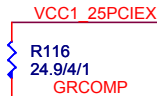
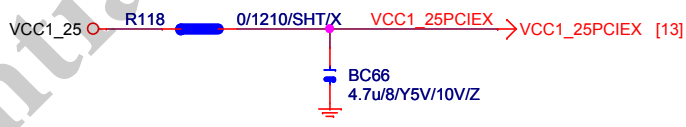
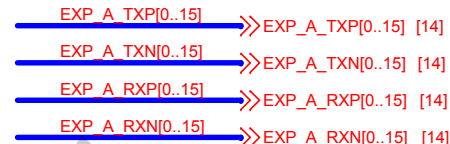
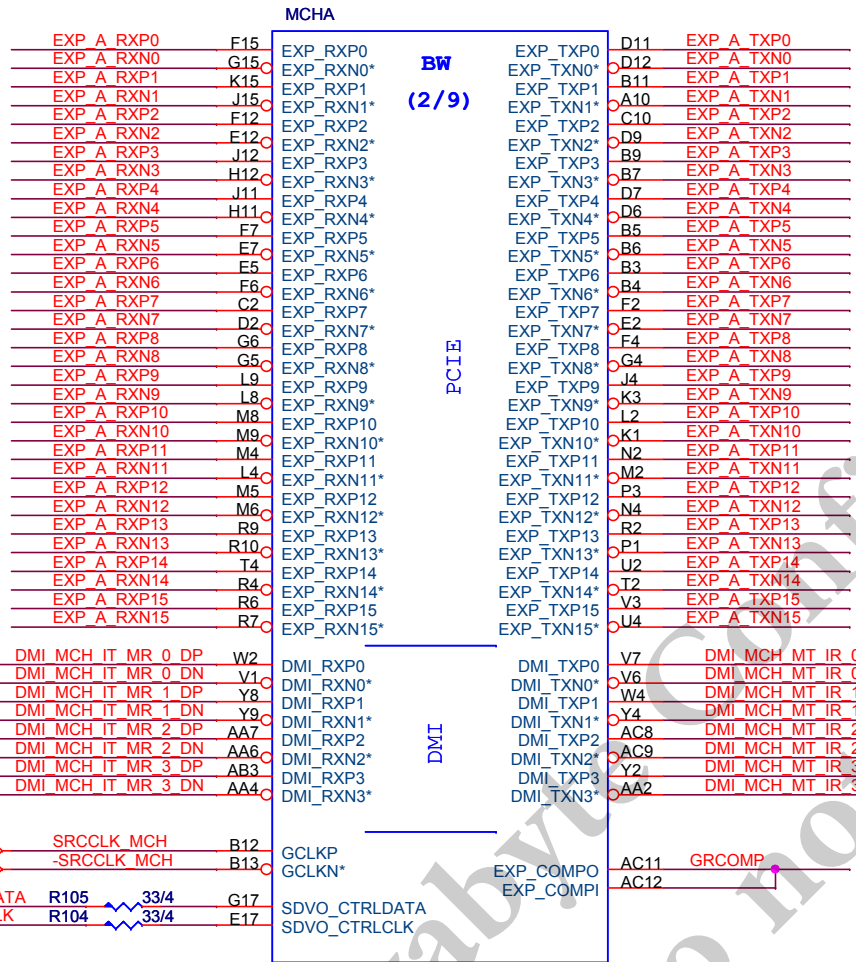

**Close to MCH**

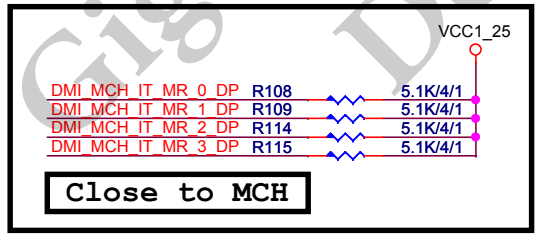
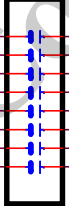

<b>Gigabyte Technology</b>			
Title <b>GMCH-PCI E &amp; DMI</b>			
Size Custom	Document Number <b>EG31M-S2</b>	Rev <b>1.02</b>	
Date: Thursday, April 10, 2008	Sheet 10	of 33	

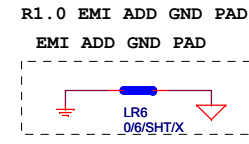
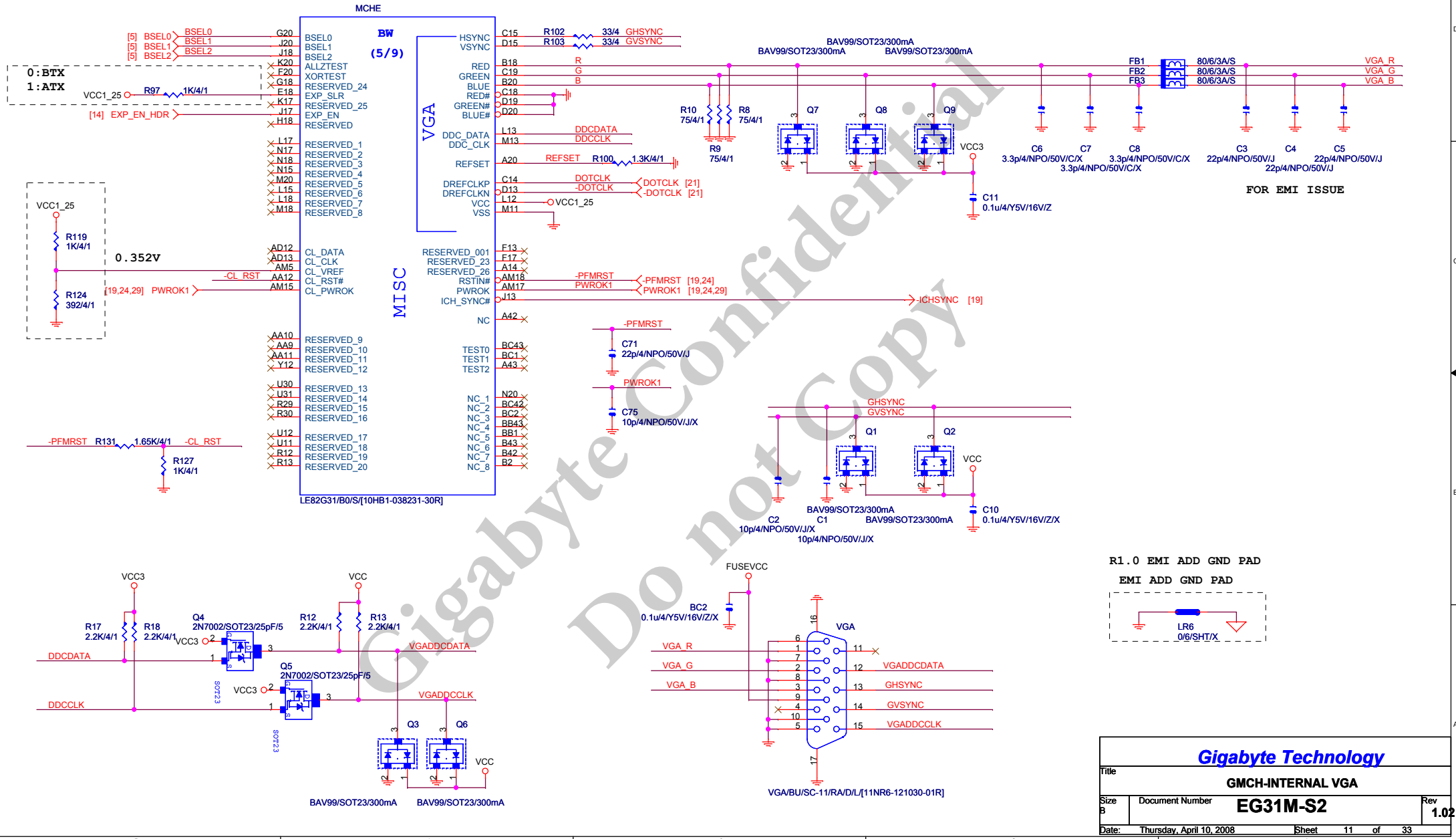

<b>Gigabyte Technology</b>		
<b>GMCH-INTERNAL VGA</b>		
Size B	Document Number	Rev 1.02
		<b>EG31M-S2</b>
Date:	Thursday, April 10, 2008	Sheet 11 of 33

**MCHG**

BC37	VSS_1	<b>BW</b>	VSS_181	AF5
BC32	VSS_2	(7/9)	VSS_182	AF3
BC28	VSS_3		VSS_183	AF2
BC24	VSS_4		VSS_184	AF1
BC10	VSS_5		VSS_185	AD42
BC5	VSS_6	<b>GND 1/2</b>	VSS_186	AD39
BB7	VSS_7		VSS_187	AD37
AY41	VSS_8		VSS_188	AD35
AY4	VSS_9		VSS_189	AD33
AW43	VSS_10		VSS_190	AD25
AW41	VSS_11		VSS_191	AD23
AV37	VSS_12		VSS_192	AD21
AV35	VSS_13		VSS_193	AD19
AV27	VSS_14		VSS_194	AC38
AV23	VSS_15		VSS_195	AC35
AV21	VSS_16		VSS_196	AC24
AV17	VSS_17		VSS_197	AC22
AV11	VSS_18		VSS_198	AC20
AV9	VSS_19		VSS_199	AC10
AV7	VSS_20		VSS_200	AC7
AU42	VSS_21		VSS_201	AC5
AU38	VSS_22		VSS_202	AB43
AU32	VSS_23		VSS_203	AB25
AU24	VSS_24		VSS_204	AB23
AU20	VSS_25		VSS_205	AB21
AU6	VSS_26		VSS_206	AB19
AU2	VSS_27		VSS_207	AB2
AT31	VSS_28		VSS_208	AB1
AT29	VSS_29		VSS_209	AA38
AT15	VSS_30		VSS_210	AA35
AT13	VSS_31		VSS_211	AA24
AT12	VSS_32		VSS_212	AA22
AR38	VSS_33		VSS_213	AA20
AR33	VSS_34		VSS_214	AA8
AR32	VSS_35		VSS_215	AA5
AR27	VSS_36		VSS_216	H21
AR26	VSS_37		VSS_217	Y42
AR23	VSS_38		VSS_218	Y37
AR21	VSS_39		VSS_219	Y35
AR20	VSS_40		VSS_220	Y33
AR17	VSS_41		VSS_221	Y25
AR9	VSS_42		VSS_222	Y23
AR6	VSS_43		VSS_223	Y21
AF43	VSS_44		VSS_224	Y19
AF24	VSS_45		VSS_225	Y10
AF18	VSS_46		VSS_226	Y7
AP1	VSS_47		VSS_227	Y5
AN38	VSS_48		VSS_228	Y1
AN31	VSS_49		VSS_229	W3
AN29	VSS_50		VSS_230	V43
AN24	VSS_51		VSS_231	V39
AN23	VSS_52		VSS_232	V37
AN20	VSS_53		VSS_233	V34
AN15	VSS_54		VSS_234	V27
AN13	VSS_55		VSS_235	V22
AN12	VSS_56		VSS_236	V11
AN11	VSS_57		VSS_237	V8
AN4	VSS_58		VSS_238	V5
AM42	VSS_59		VSS_239	V2
AM40	VSS_60		VSS_240	U38
AM36	VSS_61		VSS_241	U35
AM33	VSS_62		VSS_242	U8
AM29	VSS_63		VSS_243	U7
AM24	VSS_64		VSS_244	U5
AM23	VSS_65		VSS_245	T42
AM20	VSS_66		VSS_246	T1
AM11	VSS_67		VSS_247	R36
AM9	VSS_68		VSS_248	R33
AM7	VSS_69		VSS_249	R31
AM4	VSS_70		VSS_250	R11
AM2	VSS_71		VSS_251	R8
AM1	VSS_72		VSS_252	R5
AL36	VSS_73		VSS_253	R3
AL33	VSS_74		VSS_254	P43
Ak43	VSS_75		VSS_255	P30
AJ38	VSS_76		VSS_256	P21
AJ33	VSS_77		VSS_257	P17
AH42	VSS_78		VSS_258	P2
AG37	VSS_79		VSS_259	N36
AG34	VSS_80		VSS_260	N33
AF43	VSS_81		VSS_261	N27
AF37	VSS_82		VSS_262	N21
AF36	VSS_83		VSS_263	N13
AF10	VSS_84		VSS_264	N10
AF9	VSS_85		VSS_265	N7
AF8	VSS_86		VSS_266	N5
AF7	VSS_87		VSS_267	M42
AF6	VSS_88		VSS_268	M37
	VSS_89		VSS_269	M35
	VSS_90		VSS_270	M33

LE82G31/B0/S[10HB1-038231-30R]

**MCHI**

M27	VSS_91	<b>BW</b>	VSS_271	BC41
M21	VSS_92	(9/9)	VSS_272	BC3
M17	VSS_93		VSS_273	BA1
M15	VSS_94		VSS_274	AY40
M10	VSS_95	<b>GND 2/2</b>	VSS_275	AF23
M7	VSS_96		VSS_276	AF21
M1	VSS_97		VSS_277	AF19
L33	VSS_98		VSS_278	AF24
L32	VSS_99		VSS_279	AE22
L31	VSS_100		VSS_280	AE20
L29	VSS_101		VSS_281	AE18
L21	VSS_102		VSS_282	AC18
L20	VSS_103		VSS_283	AA18
L11	VSS_104		VSS_284	W24
L7	VSS_105		VSS_285	W22
L5	VSS_106		VSS_286	W20
L3	VSS_107		VSS_287	R21
K43	VSS_108		VSS_288	E1
K26	VSS_109		VSS_289	C43
K21	VSS_110		VSS_290	C1
K18	VSS_111		VSS_291	A41
K13	VSS_112		VSS_292	A5
K12	VSS_113		VSS_293	A3
K2	VSS_114			
J38	VSS_115			
J35	VSS_116			
J32	VSS_117			
J27	VSS_118			
J21	VSS_119			
J9	VSS_120			
J7	VSS_121			
J5	VSS_122			
H31	VSS_123			
H29	VSS_124			
H21	VSS_125			
H20	VSS_126			
H17	VSS_127			
H15	VSS_128			
H13	VSS_129			
G42	VSS_130			
G38	VSS_131			
G32	VSS_132			
G21	VSS_133			
G13	VSS_134			
G12	VSS_135			
G11	VSS_136			
G9	VSS_137			
G7	VSS_138			
G1	VSS_139			
F37	VSS_140			
F35	VSS_141			
F27	VSS_142			
F21	VSS_143			
F18	VSS_144			
F3	VSS_145			
F43	VSS_146			
E32	VSS_147			
E24	VSS_148			
E21	VSS_149			
E20	VSS_150			
E15	VSS_151			
E13	VSS_152			
E11	VSS_153			
E9	VSS_154			
E3	VSS_155			
D40	VSS_156			
D31	VSS_157			
D21	VSS_158			
D17	VSS_159			
D3	VSS_160			
C26	VSS_161			
C11	VSS_162			
C6	VSS_163			
C5	VSS_164			
C4	VSS_165			
B37	VSS_166			
B32	VSS_167			
B31	VSS_168			
B26	VSS_169			
B23	VSS_170			
B22	VSS_171			
B19	VSS_172			
B14	VSS_173			
B10	VSS_174			
A39	VSS_175			
A34	VSS_176			
A26	VSS_177			
A18	VSS_178			
A12	VSS_179			
A7	VSS_180			

LE82G31/B0/S[10HB1-038231-30R]

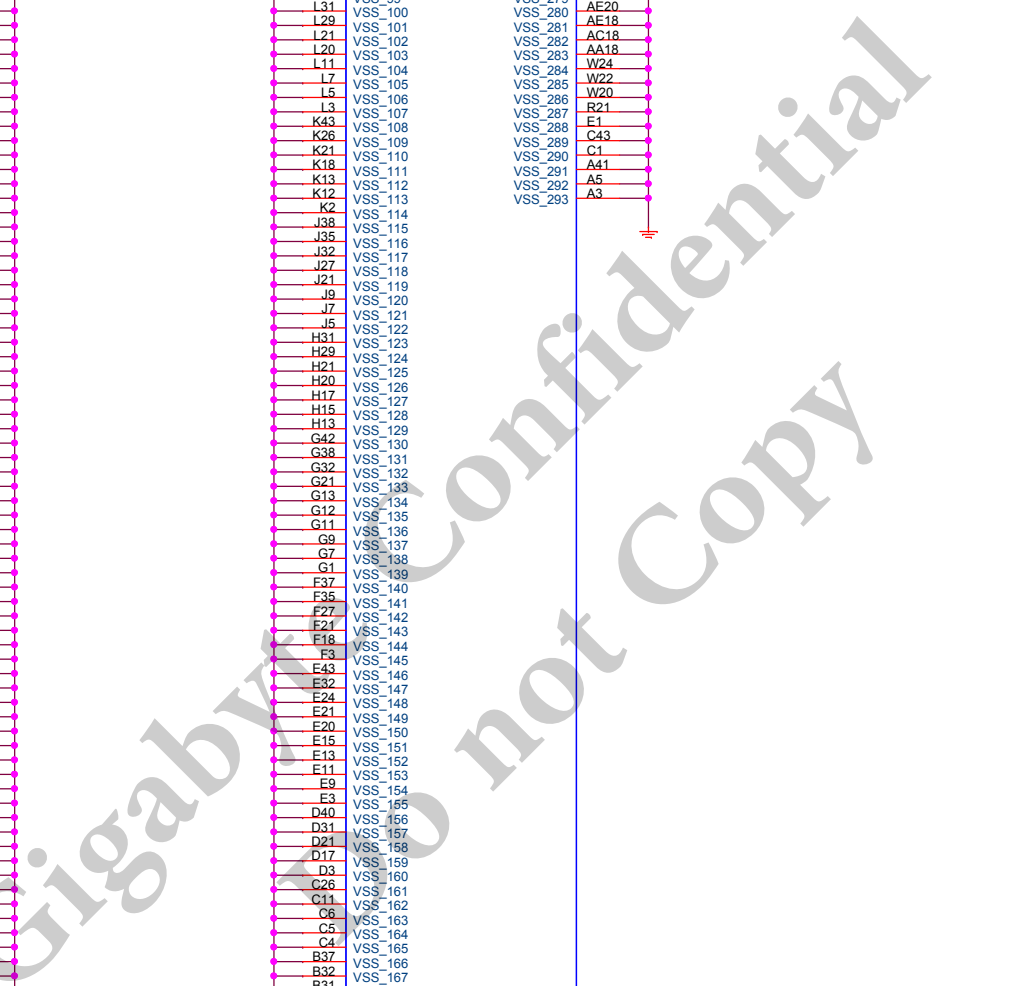
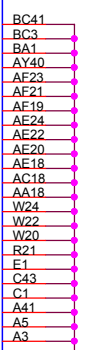

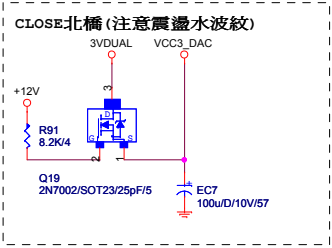
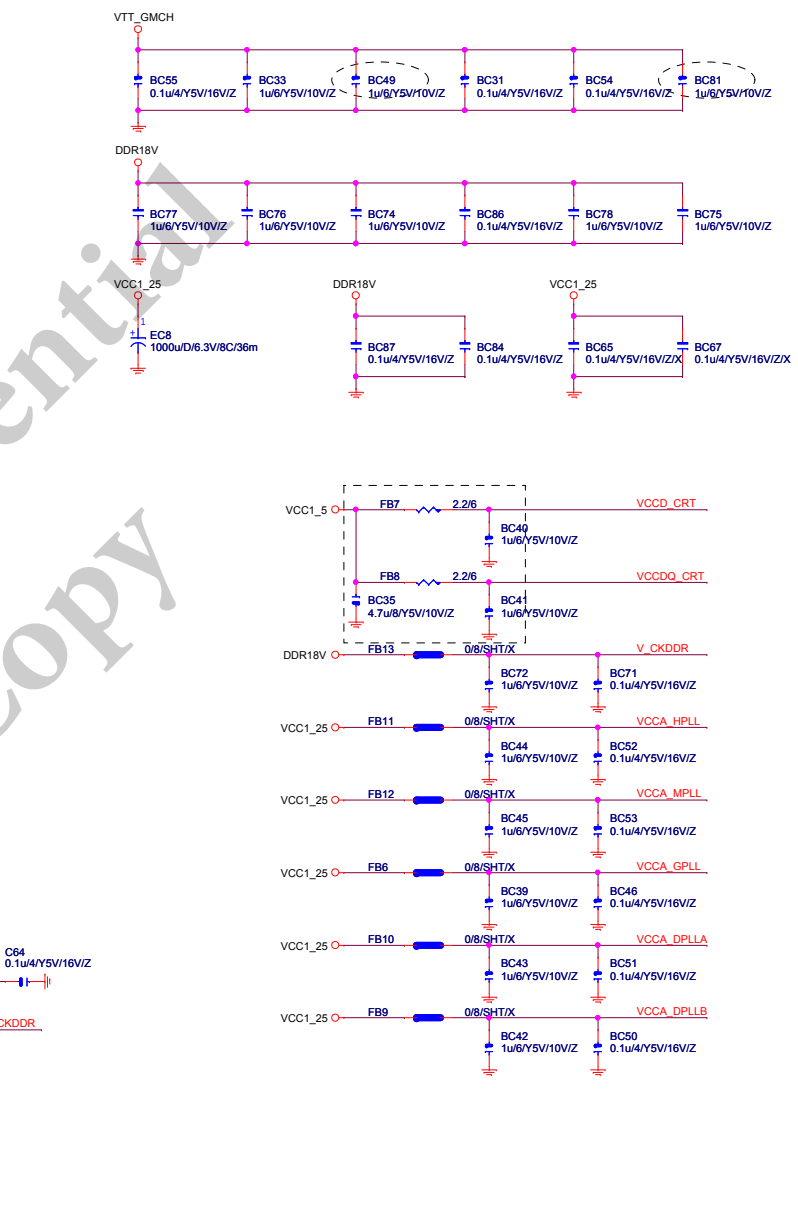
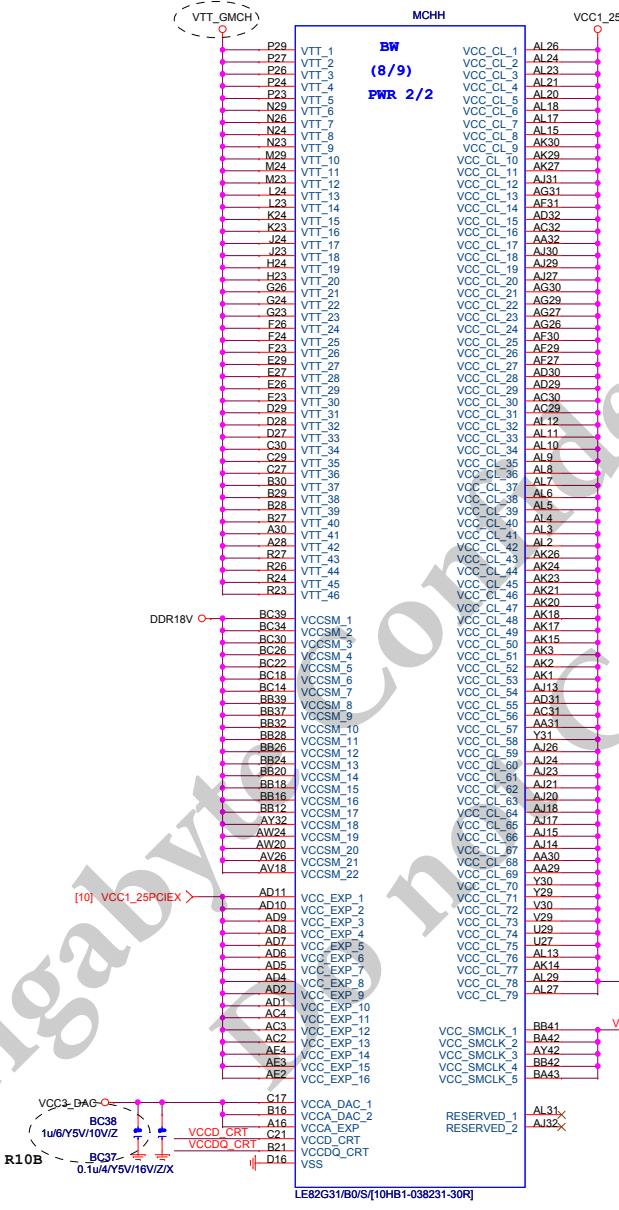
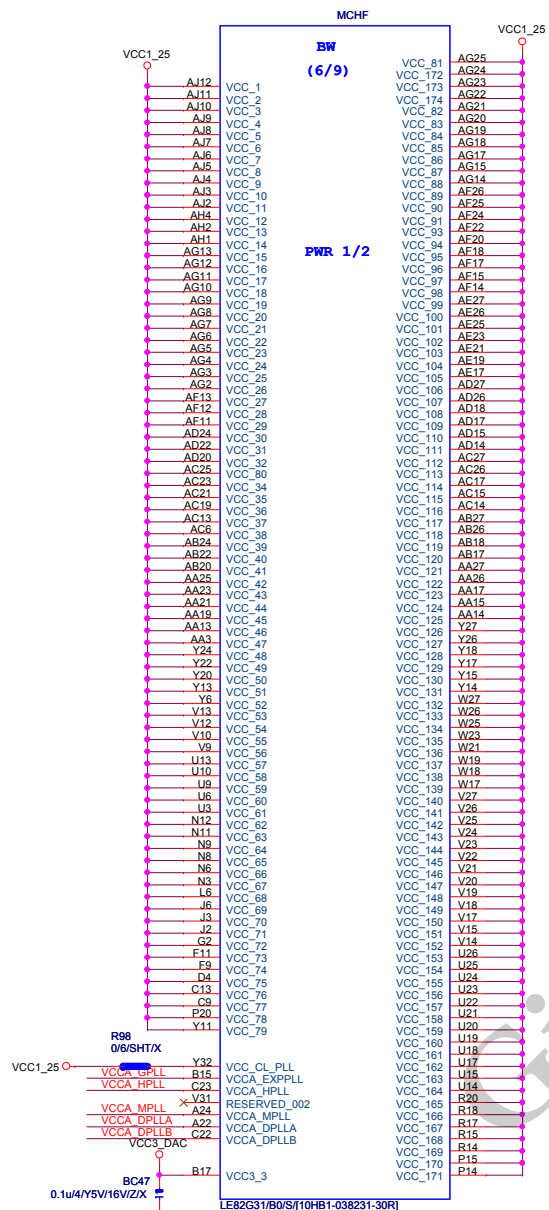

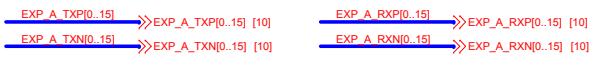
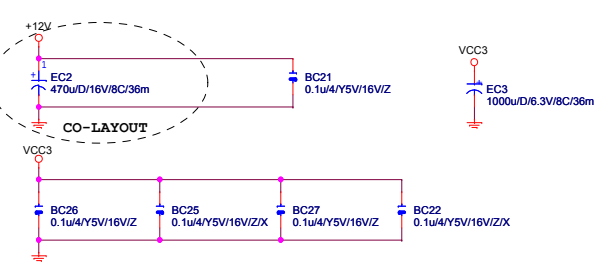

EXP_A_TXP0	C36	0.1uF/4Y5V/16V/Z	EXP_A_TXP0C
EXP_A_TXN0	C35	0.1uF/4Y5V/16V/Z	EXP_A_TXN0C
EXP_A_TXP1	C37	0.1uF/4Y5V/16V/Z	EXP_A_TXP1C
EXP_A_TXN1	C38	0.1uF/4Y5V/16V/Z	EXP_A_TXN1C
EXP_A_TXP2	C39	0.1uF/4Y5V/16V/Z	EXP_A_TXP2C
EXP_A_TXN2	C40	0.1uF/4Y5V/16V/Z	EXP_A_TXN2C
EXP_A_TXP3	C41	0.1uF/4Y5V/16V/Z	EXP_A_TXP3C
EXP_A_TXN3	C42	0.1uF/4Y5V/16V/Z	EXP_A_TXN3C
EXP_A_TXP4	C43	0.1uF/4Y5V/16V/Z	EXP_A_TXP4C
EXP_A_TXN4	C44	0.1uF/4Y5V/16V/Z	EXP_A_TXN4C
EXP_A_TXP5	C46	0.1uF/4Y5V/16V/Z	EXP_A_TXP5C
EXP_A_TXN5	C45	0.1uF/4Y5V/16V/Z	EXP_A_TXN5C
EXP_A_TXP6	C48	0.1uF/4Y5V/16V/Z	EXP_A_TXP6C
EXP_A_TXN6	C47	0.1uF/4Y5V/16V/Z	EXP_A_TXN6C
EXP_A_TXP7	C50	0.1uF/4Y5V/16V/Z	EXP_A_TXP7C
EXP_A_TXN7	C49	0.1uF/4Y5V/16V/Z	EXP_A_TXN7C
EXP_A_TXP8	C51	0.1uF/4Y5V/16V/Z	EXP_A_TXP8C
EXP_A_TXN8	C53	0.1uF/4Y5V/16V/Z	EXP_A_TXN8C
EXP_A_TXP9	C65	0.1uF/4Y5V/16V/Z	EXP_A_TXP9C
EXP_A_TXN9	C66	0.1uF/4Y5V/16V/Z	EXP_A_TXN9C
EXP_A_TXP10	C70	0.1uF/4Y5V/16V/Z	EXP_A_TXP10C
EXP_A_TXN10	C68	0.1uF/4Y5V/16V/Z	EXP_A_TXN10C
EXP_A_TXP11	C73	0.1uF/4Y5V/16V/Z	EXP_A_TXP11C
EXP_A_TXN11	C72	0.1uF/4Y5V/16V/Z	EXP_A_TXN11C
EXP_A_TXP12	C76	0.1uF/4Y5V/16V/Z	EXP_A_TXP12C
EXP_A_TXN12	C74	0.1uF/4Y5V/16V/Z	EXP_A_TXN12C
EXP_A_TXP13	C79	0.1uF/4Y5V/16V/Z	EXP_A_TXP13C
EXP_A_TXN13	C78	0.1uF/4Y5V/16V/Z	EXP_A_TXN13C
EXP_A_TXP14	C81	0.1uF/4Y5V/16V/Z	EXP_A_TXP14C
EXP_A_TXN14	C80	0.1uF/4Y5V/16V/Z	EXP_A_TXN14C
EXP_A_TXP15	C83	0.1uF/4Y5V/16V/Z	EXP_A_TXP15C
EXP_A_TXN15	C82	0.1uF/4Y5V/16V/Z	EXP_A_TXN15C

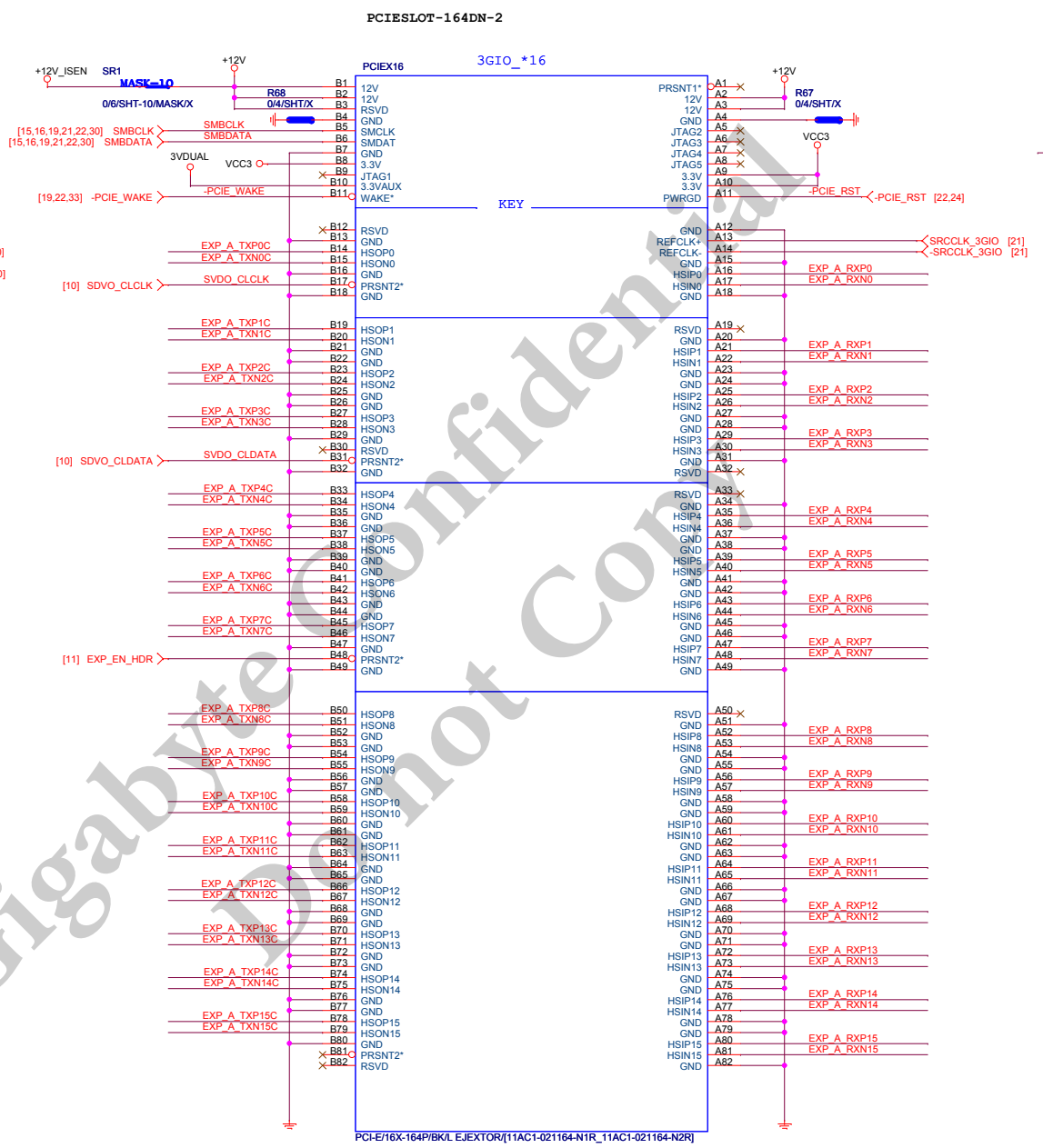

Gigabyte Confidential

LEFT BLUE

<b>Gigabyte Technology</b>		
Title		
PCI EXPRESS * 16		
Size	Document Number	Rev
Custom	<b>EG31M-S2</b>	<b>1.02</b>
Date:	Thursday, April 10, 2008	Sheet 14 of 33



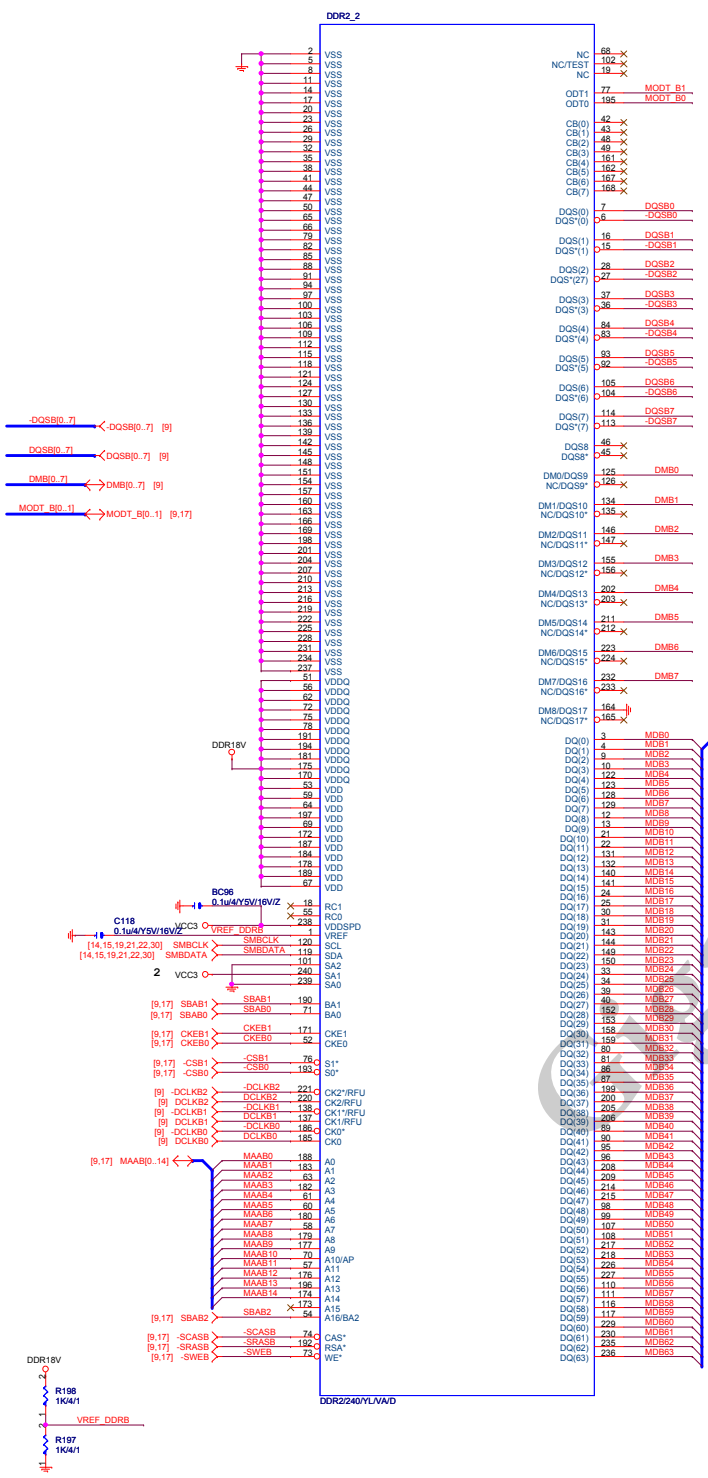



# DDR TERMINATION CHANNEL A

## DDRVTT Decouple

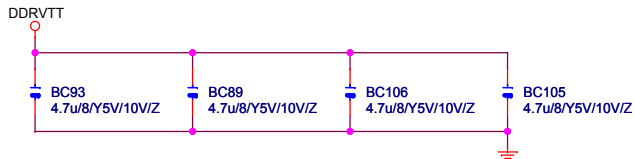
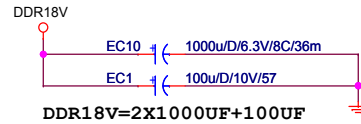

## DDR18V Decouple

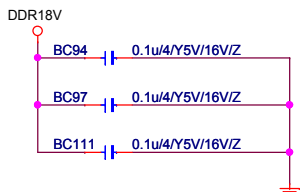

## DDRVTT Decouple

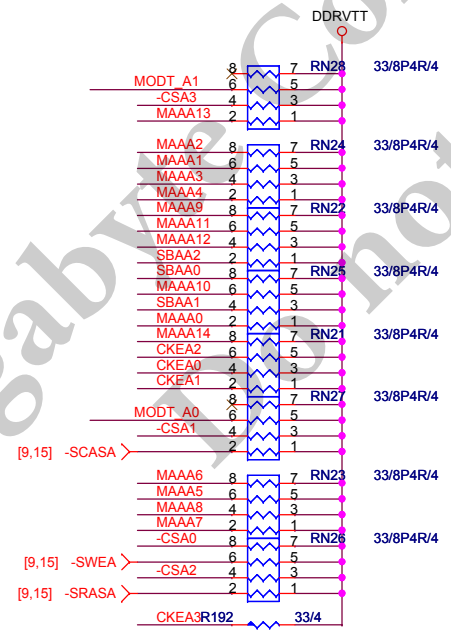
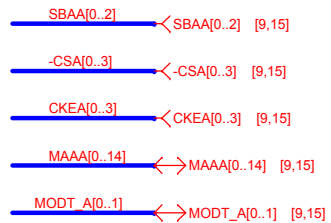
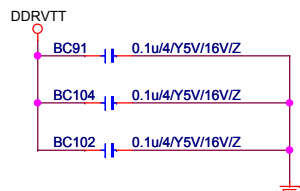

# DDR TERMINATION CHANNEL B

## DDR18V Decouple

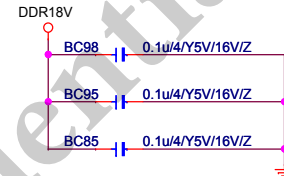

## DDRVTT Decouple

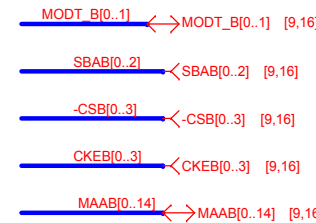
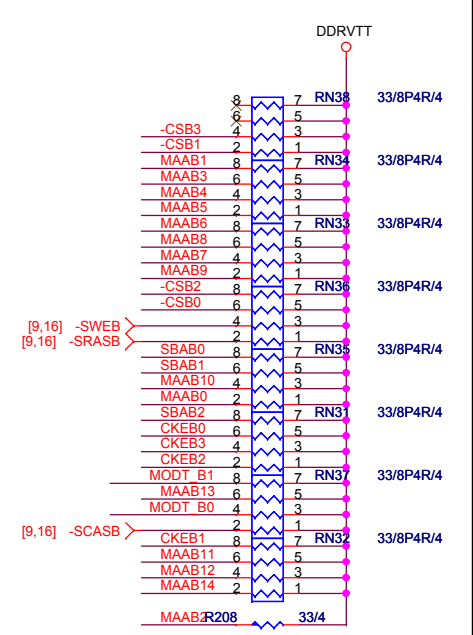
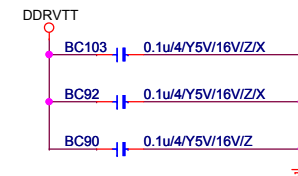

**Gigabyte Technology**

Title		
DDR II TERMINATOR		
Size	Document Number	Rev
Custom	EG31M-S2	1.02
Date:	Thursday, April 10, 2008	Sheet 17 of 33





ICHF		
A4	VSS1	R14
A23	VSS2	R15
B1	VSS3	R16
B8	VSS4	R17
B11	VSS5	R18
B14	VSS6	T1
B17	VSS7	T2
B20	VSS8	T3
B26	VSS9	T4
B28	VSS10	T5
C2	VSS11	T6
D6	VSS12	T7
D10	VSS13	T8
D13	VSS14	T9
D18	VSS15	T10
D21	VSS16	T11
D24	VSS17	T12
E1	VSS18	T13
E2	VSS19	T14
E8	VSS20	T15
E15	VSS21	T16
F3	VSS22	T17
F4	VSS23	T18
F5	VSS24	T19
F12	VSS25	T20
F27	VSS26	T21
F28	VSS27	T22
G1	VSS28	T23
G2	VSS29	T24
G5	VSS30	T25
G6	VSS31	T26
G9	VSS32	T27
G14	VSS33	T28
G18	VSS34	T29
G21	VSS35	T30
G24	VSS36	T31
G25	VSS37	T32
G26	VSS38	T33
H3	VSS39	T34
H4	VSS40	T35
H5	VSS41	T36
H24	VSS42	T37
H27	VSS43	T38
H28	VSS44	T39
J1	VSS45	T40
J5	VSS46	T41
J24	VSS47	T42
J25	VSS48	T43
J26	VSS49	T44
J26	VSS50	T45
K24	VSS51	T46
K27	VSS52	T47
K28	VSS53	T48
L13	VSS54	T49
L15	VSS55	T50
L24	VSS56	T51
L25	VSS57	T52
L26	VSS58	T53
M3	VSS59	T54
M4	VSS60	T55
M12	VSS61	T56
M13	VSS62	T57
M14	VSS63	T58
M15	VSS64	T59
M16	VSS65	T60
M17	VSS66	T61
M24	VSS67	T62
M27	VSS68	T63
M28	VSS69	T64
N1	VSS70	T65
N2	VSS71	T66
N5	VSS72	T67
N6	VSS73	T68
N11	VSS74	T69
N12	VSS75	T70
N13	VSS76	T71
N14	VSS77	T72
N15	VSS78	T73
N16	VSS79	T74
N17	VSS80	T75
N18	VSS81	T76
N24	VSS82	T77
N25	VSS83	T78
N26	VSS84	T79
P3	VSS85	T80
P4	VSS86	T81
P12	VSS87	T82
P13	VSS88	T83
P14	VSS89	T84
P15	VSS90	T85
P16	VSS91	T86
P17	VSS92	T87
P24	VSS93	T88
P27	VSS94	T89
P28	VSS95	T90
R1	VSS96	T91
R11	VSS97	T92
R12	VSS98	T93
R13	VSS99	T94
	VSS100	T95

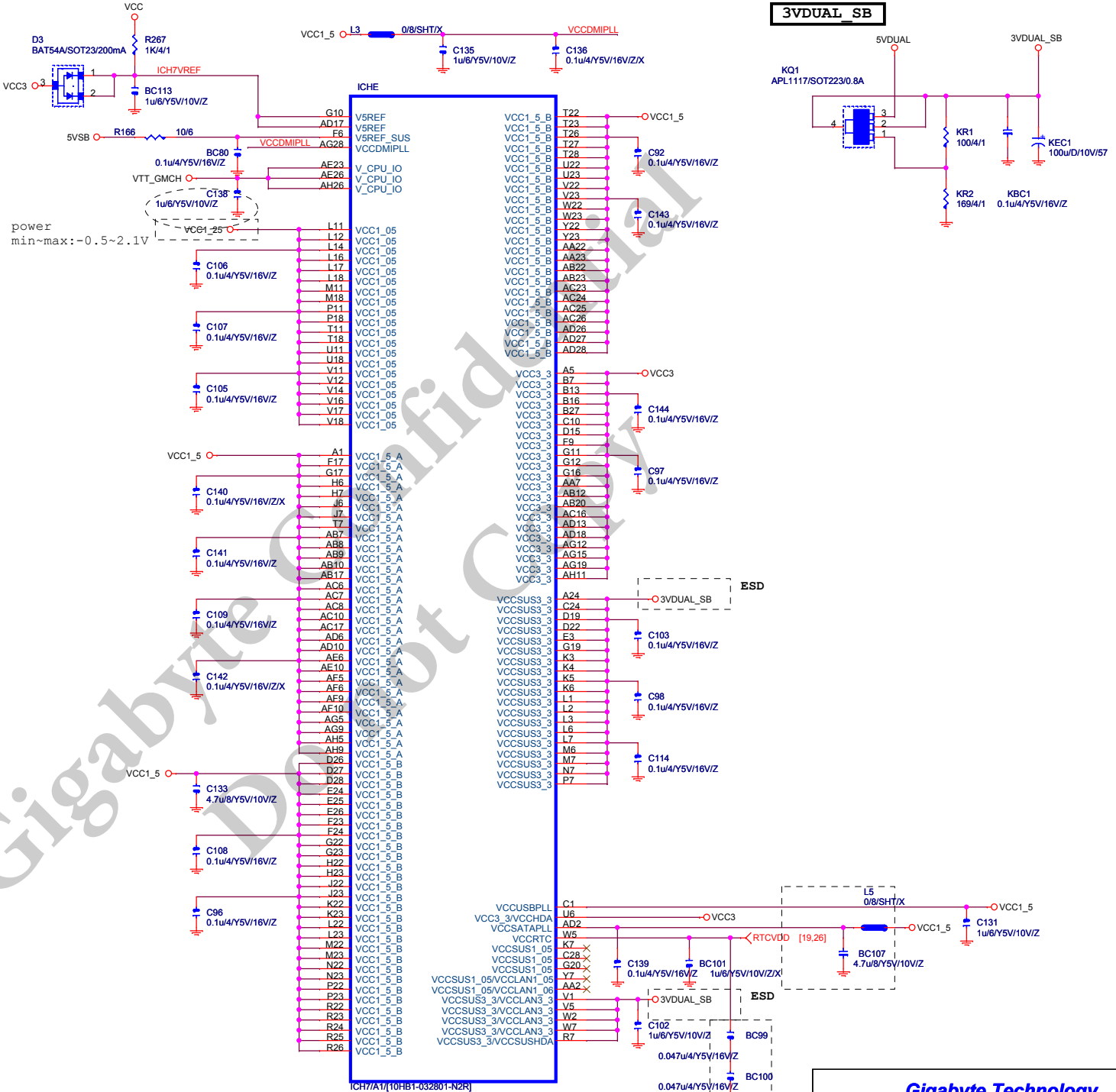

**3VDUAL\_SB**

**Gigabyte Technology**

Title		<b>ICH7-PWR &amp; GND</b>	
Size	Document Number	<b>EG31M-S2</b>	
Date:	Thursday, April 10, 2008	Sheet	20 of 33

Rev **1.02**

FOR  
漏電

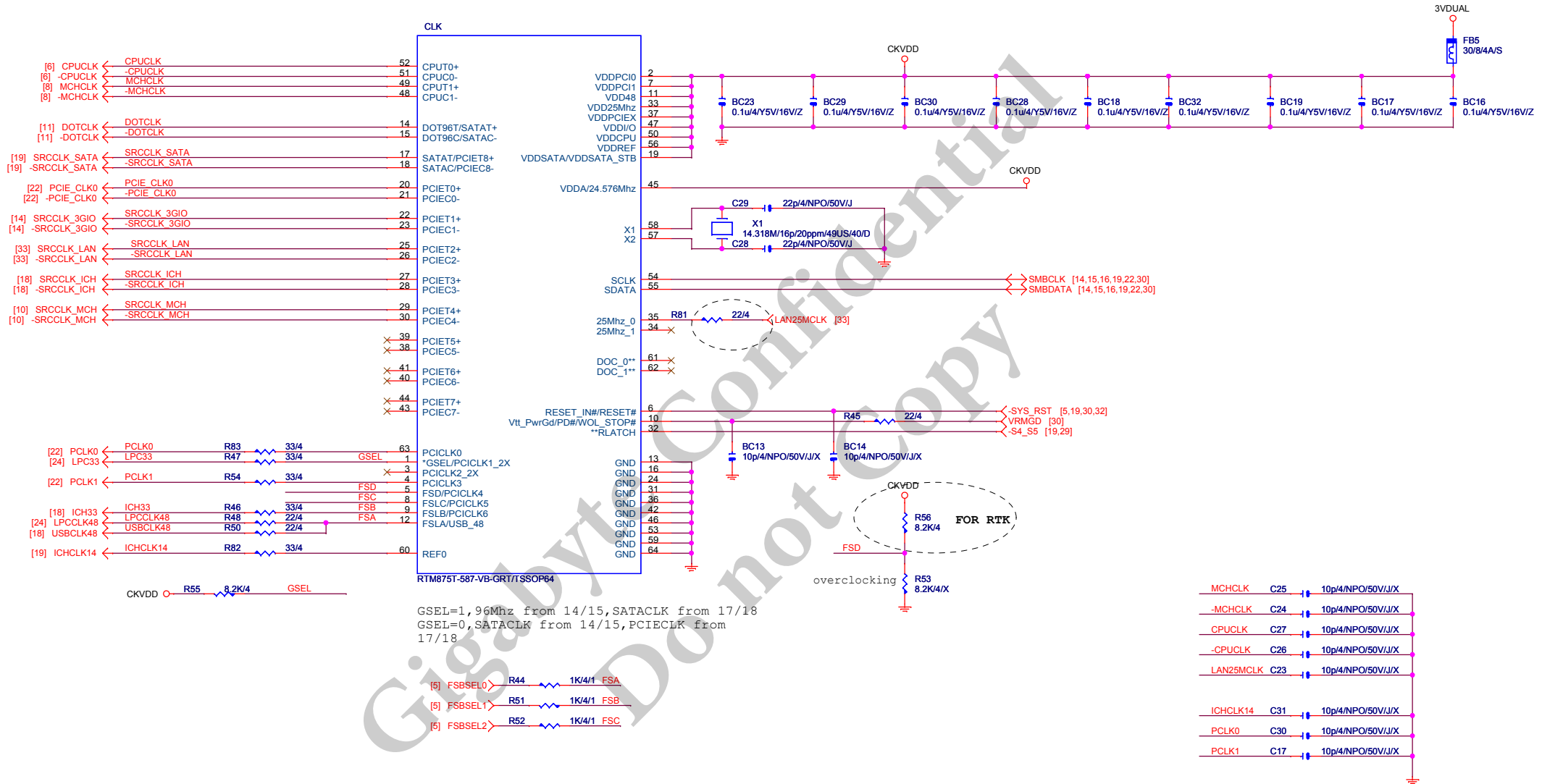

**PCI1, 2 SLOT**

**PCIEX1**

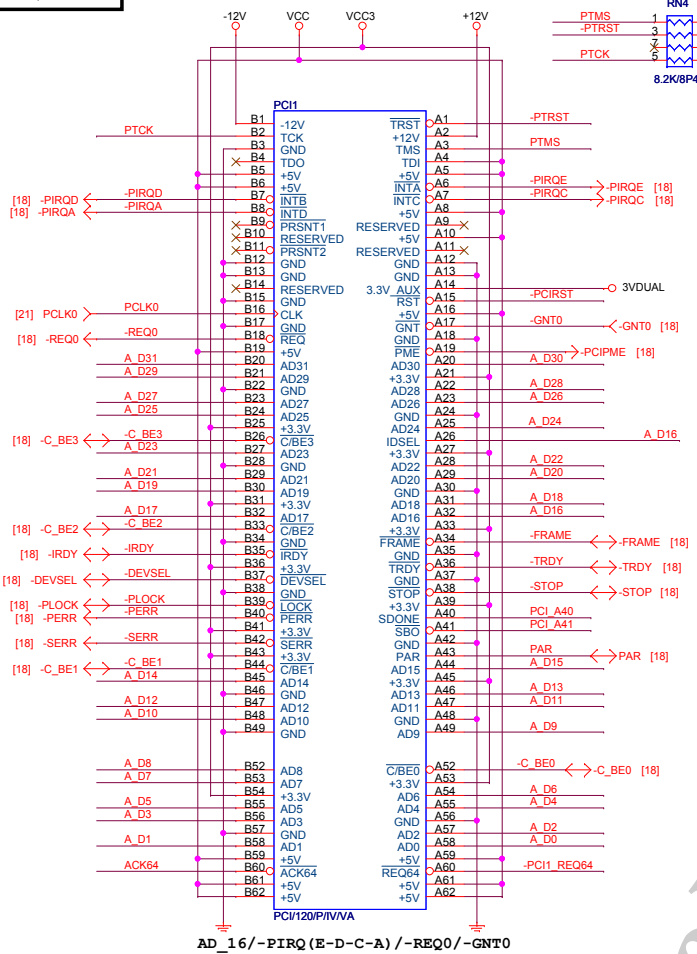

AD\_16/-PIRQ (E-D-C-A) /-REQ0/-GNT0

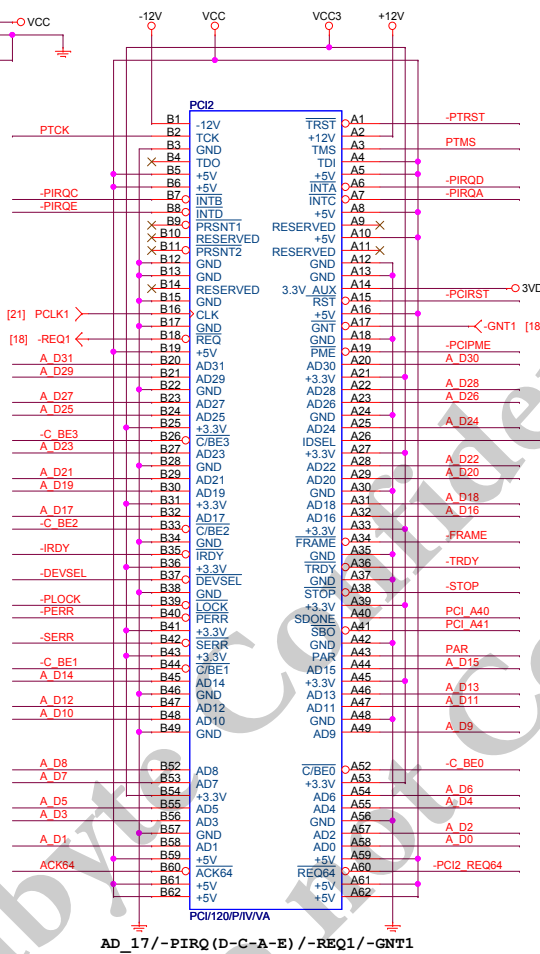

AD\_17/-PIRQ (D-C-A-E) /-REQ1/-GNT1

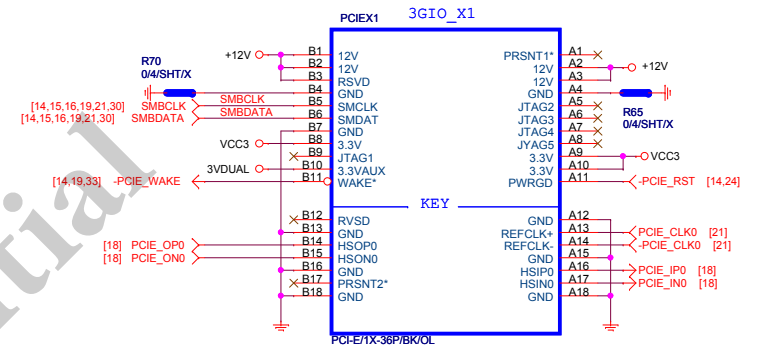

PCIEX1 3GIO\_X1

PCI-E/1X-36P/BK/OL

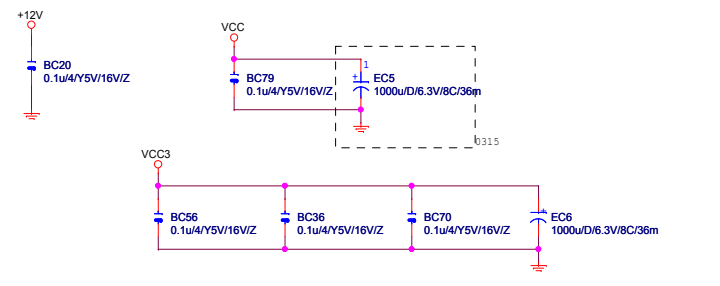
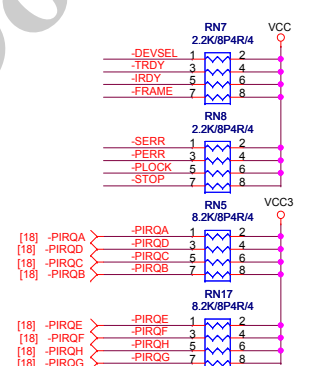
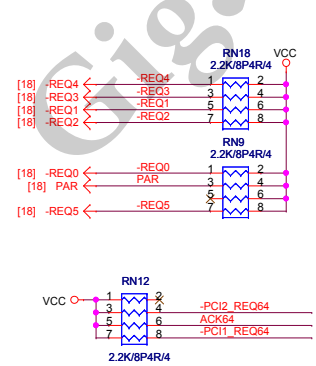
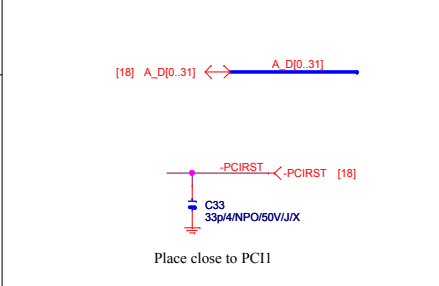

<b>Gigabyte Technology</b>		
<b>PCI SLOT 1, 2/PCIEX1</b>		
<b>EG31M-S2</b>		
File	Document Number	Rev
Custom		1.02
Date:	Thursday, April 10, 2008	Sheet 22 of 33

**IDE/SATA LED**

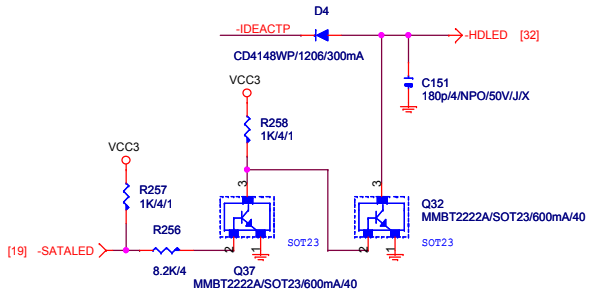

**IDE RESET**

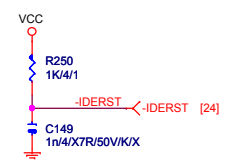

**FLOPPY**

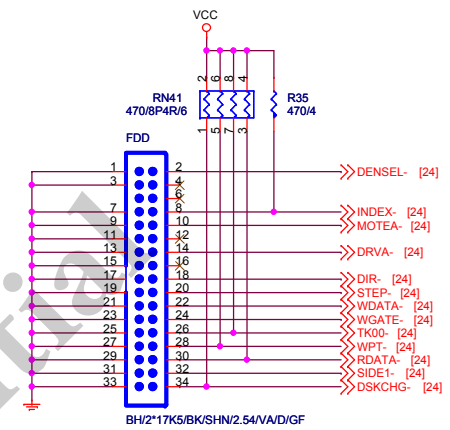

**IDE**

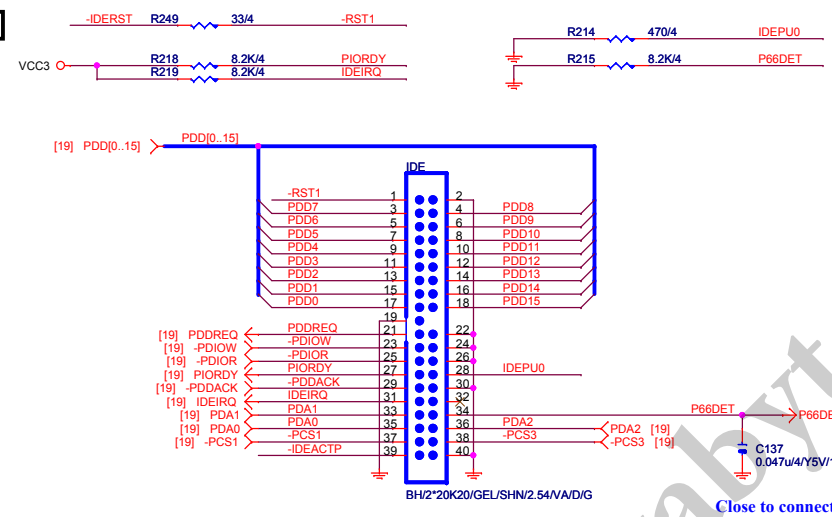

**FRONT USB1**

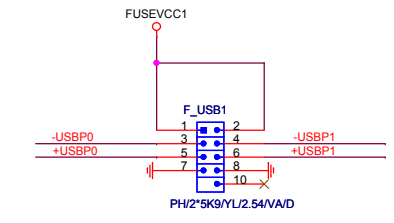
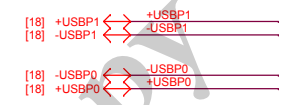

**FRONT USB2**

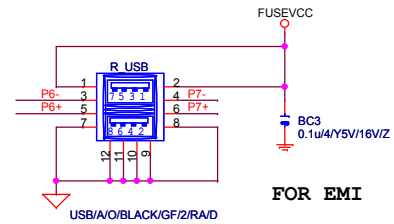
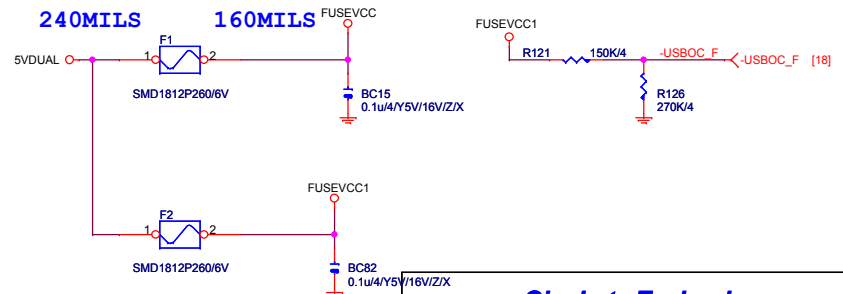
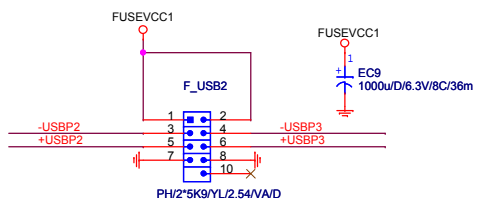
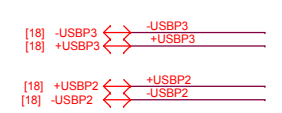

**Gigabyte Technology**

Title		
IDE,FDD,F_USB		
Size	Document Number	Rev
B	EG31M-S2	1.02
Date:	Thursday, April 10, 2008	Sheet 23 of 33





**COMA**

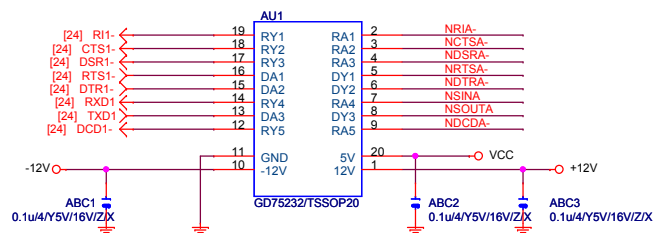

**RING IN**

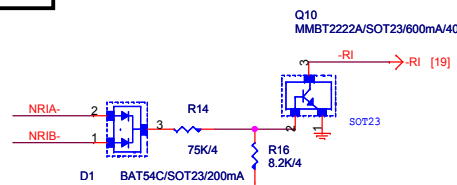

**EXTERNAL COMA**

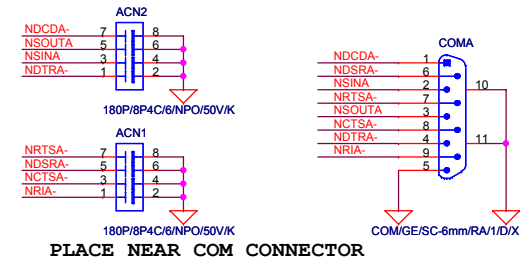

**COMB**

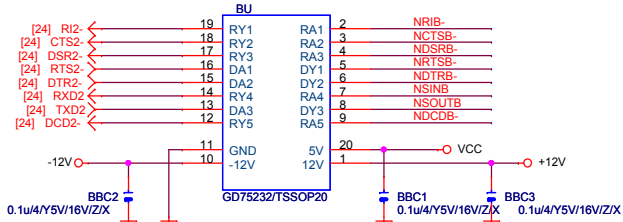

**INTERNAL COMB**

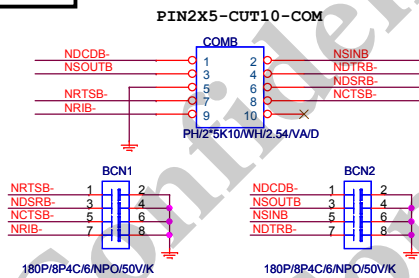

**LPT PORT**

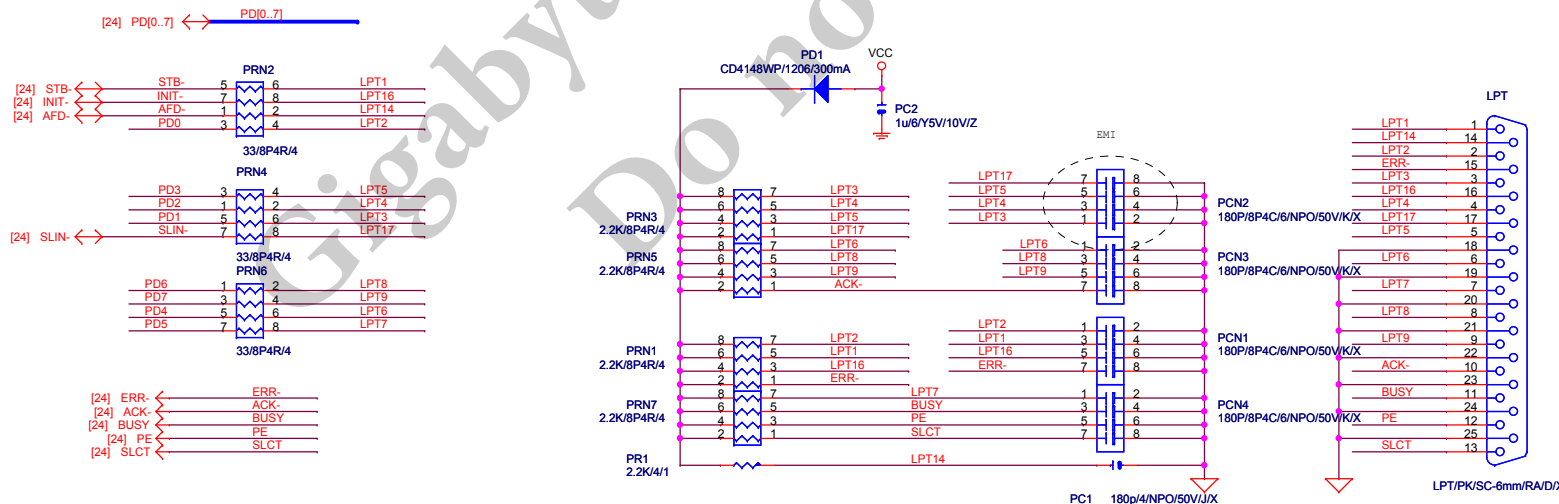

**TEMP H/W MONITOR**

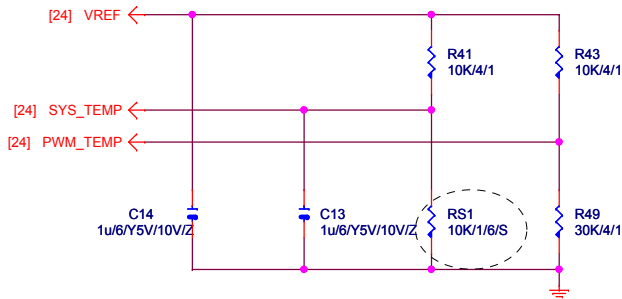

CI	ST	ST status
0	1	OK
1	0	OK
0	0	FAIL
1	1	FAIL

**VOLTAGE-- H/W MONITOR**

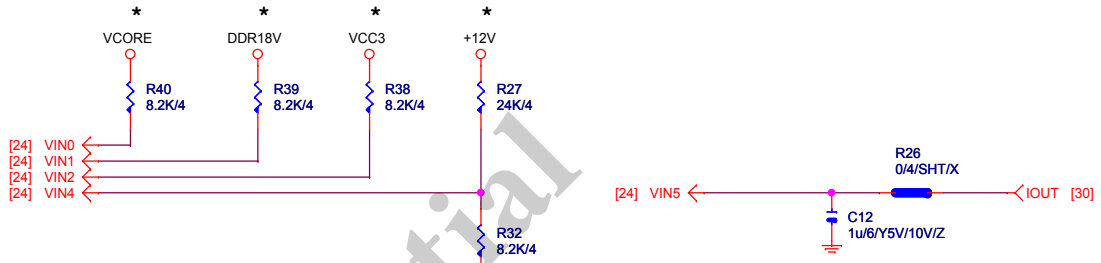

**CASE OPEN** Case Open Circuits

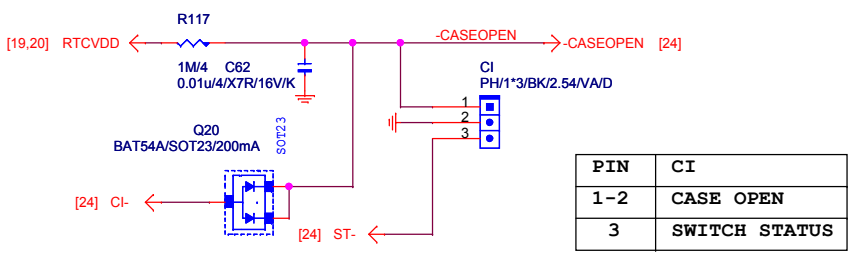

PIN	CI
1-2	CASE OPEN
3	SWITCH STATUS

**BIOS**

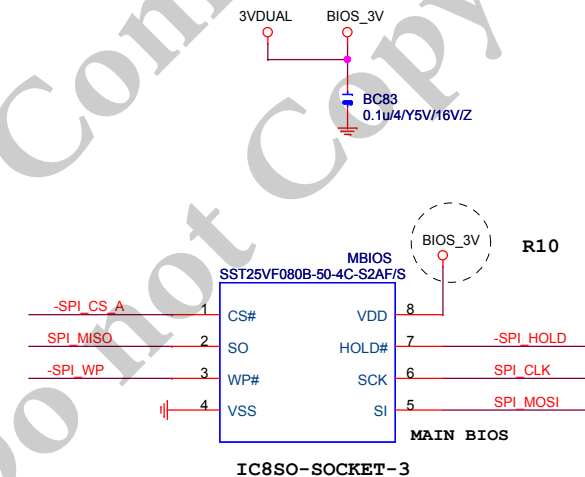

**KB/MS**

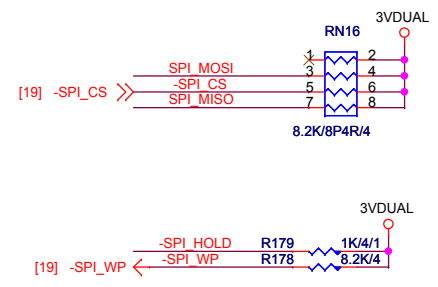
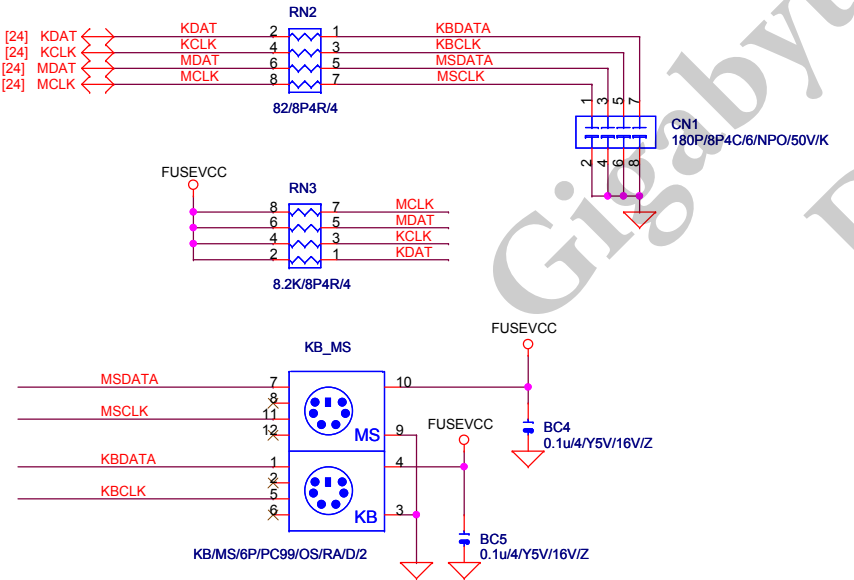

**Gigabyte Technology**

**HW-MONITOR/CI/KB/MS/BIOS**

**EG31M-S2**

Date: Thursday, April 10, 2008      Sheet 26 of 33      Rev 1.02

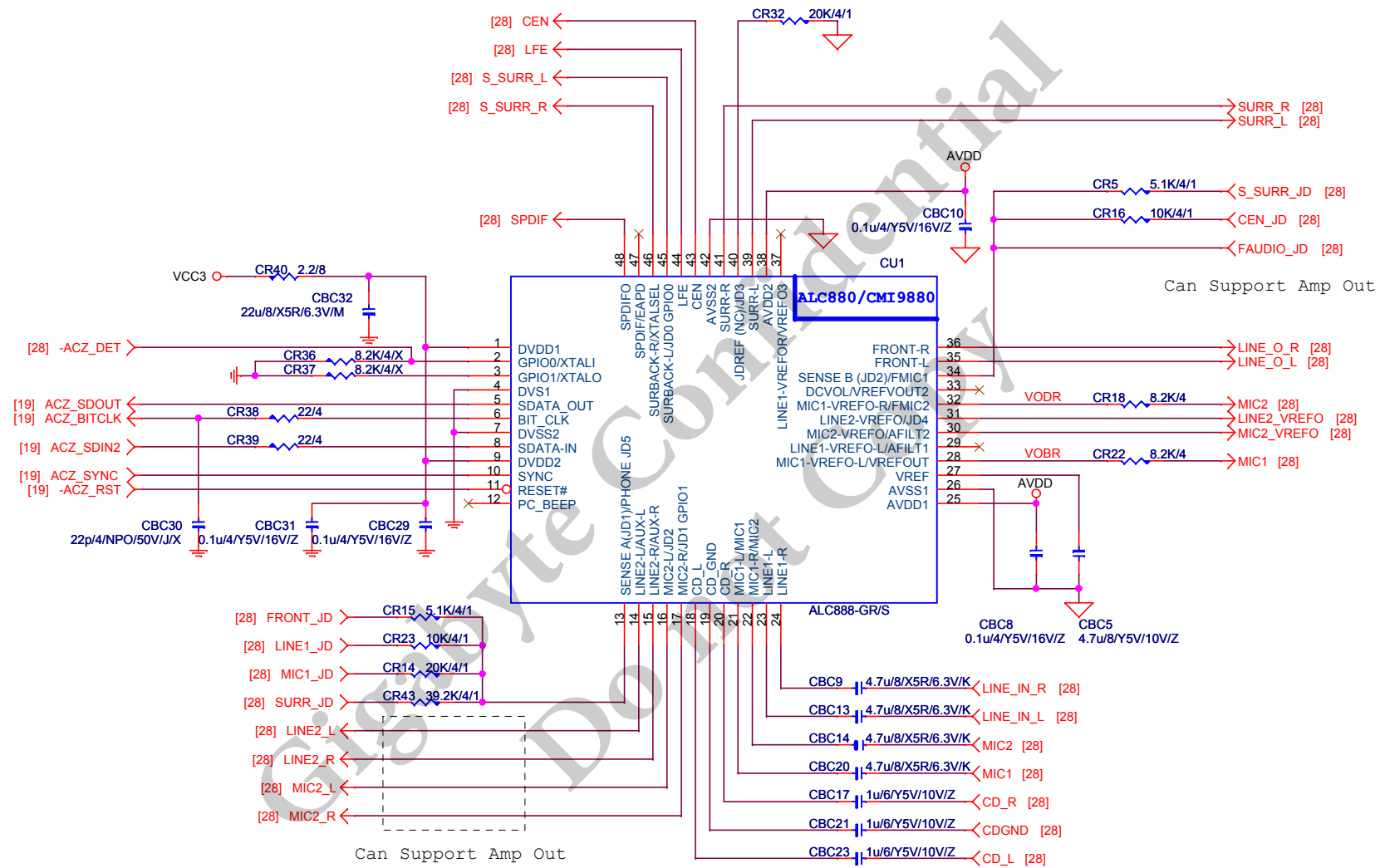

**Gigabyte Technology**

Title		
AZALIA ALC888		
Size	Document Number	Rev
Custom	EG31M-S2	1.02
Date:	Thursday, April 10, 2008	Sheet 27 of 33

**CODEC POWER/EMI PAD**

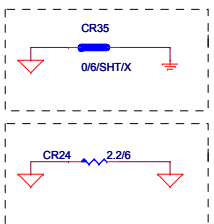
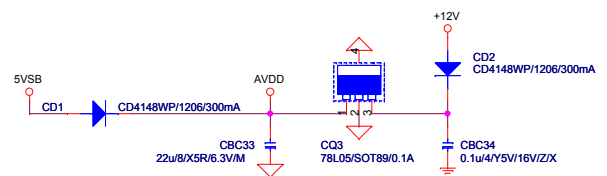

**CD IN**

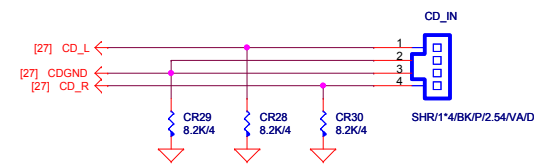

**SPDIF**

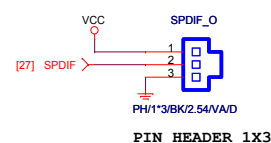

**AZALIA JACK**

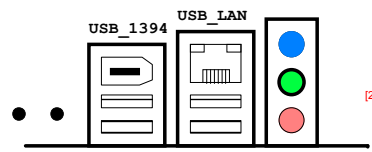

-SUR\_DET: cable detect to SB or I/O  
default : high  
insert cable : low

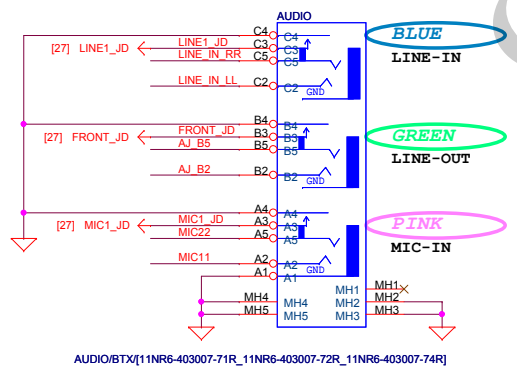
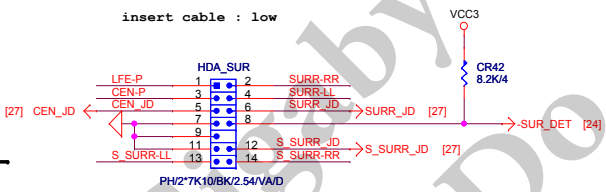

AUDIO/8TX[11NR6-403007-71R\_11NR6-403007-72R\_11NR6-403007-74R]

**LINE-OUT**

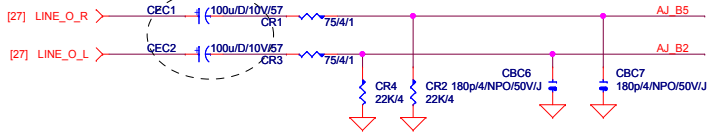

**LINE-IN**

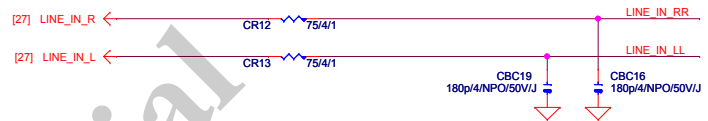

**MIC-IN**

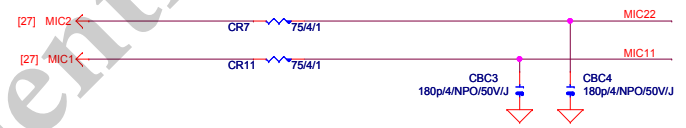

**SURROUND**

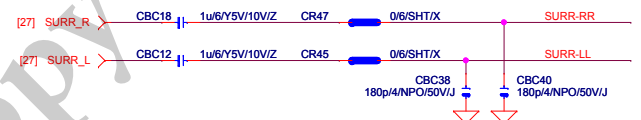

**CEN/LFE**

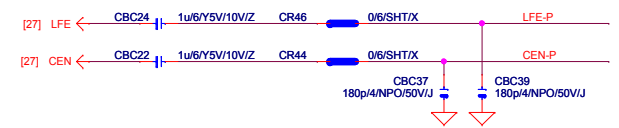

**SURR BACK**

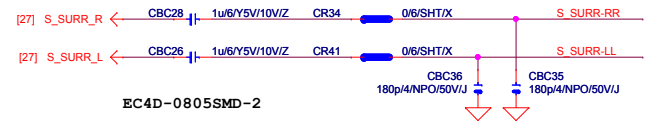

**AZALIA FRONT PANEL**

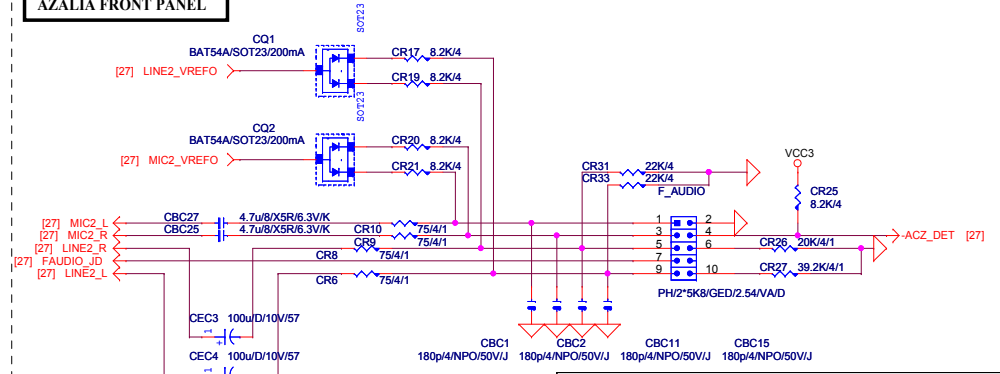

**Gigabyte Technology**

**AUDIO JACK**

**EG31M-S2**

Rev 1.02

Date: Thursday, April 10, 2008 Sheet 28 of 33

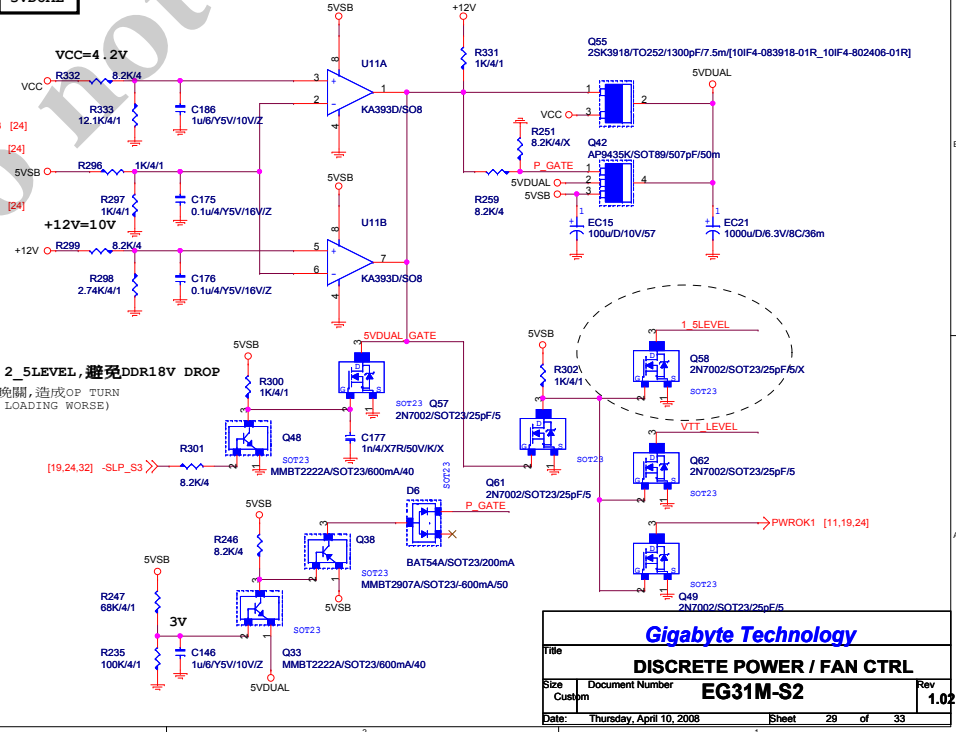
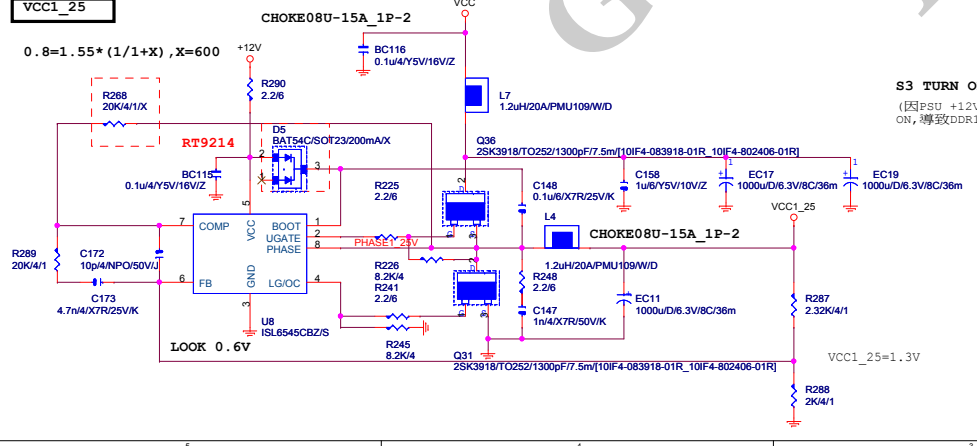
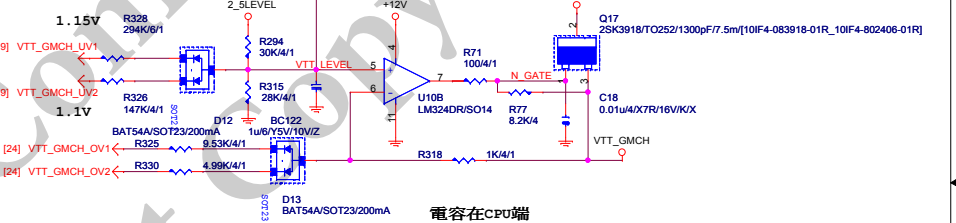
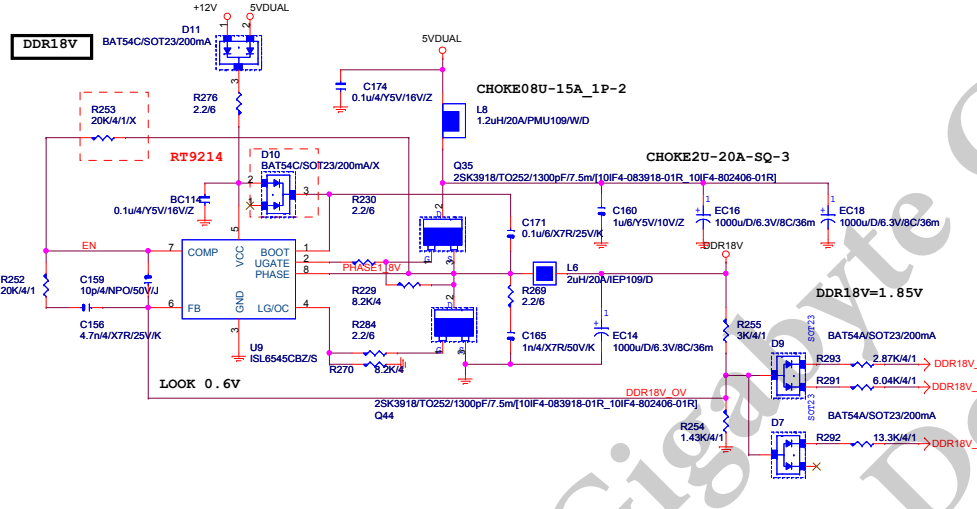
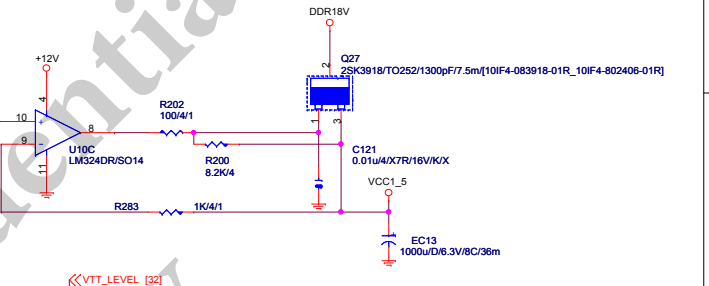
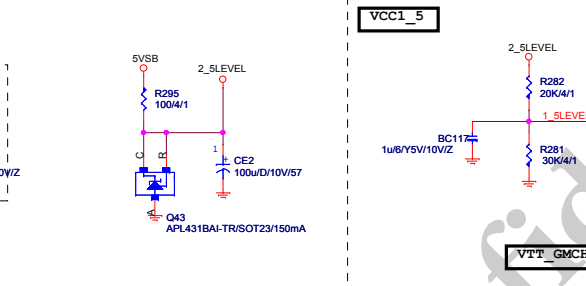
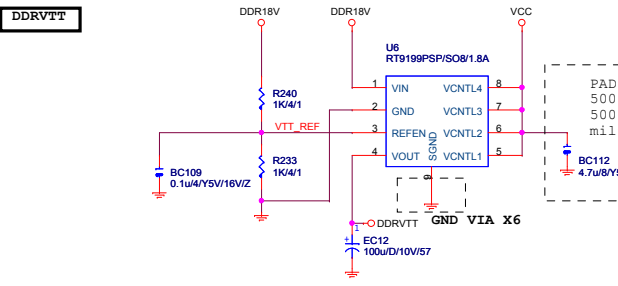
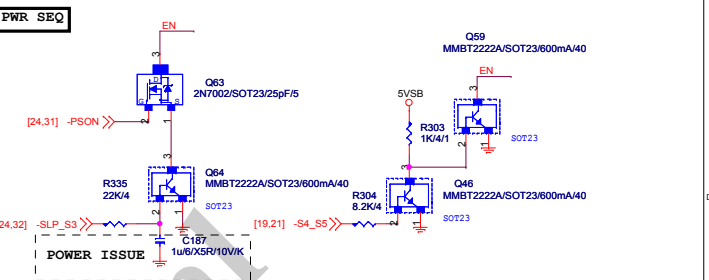
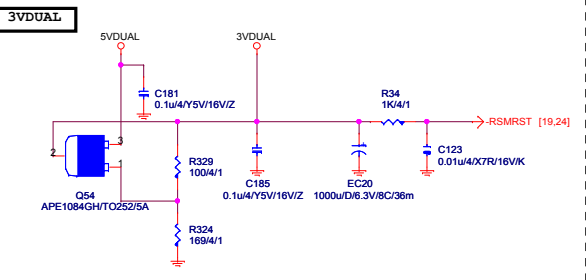
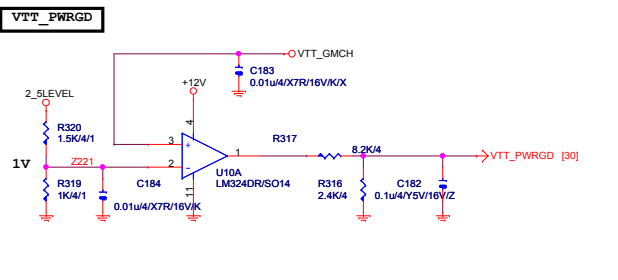

S3 TURN OFF 2\_5LEVEL, 避免DDR18V DROP  
(因PSU +12V太晚關, 造成OP TURN ON, 導致DDR18V LOADING WORSE)

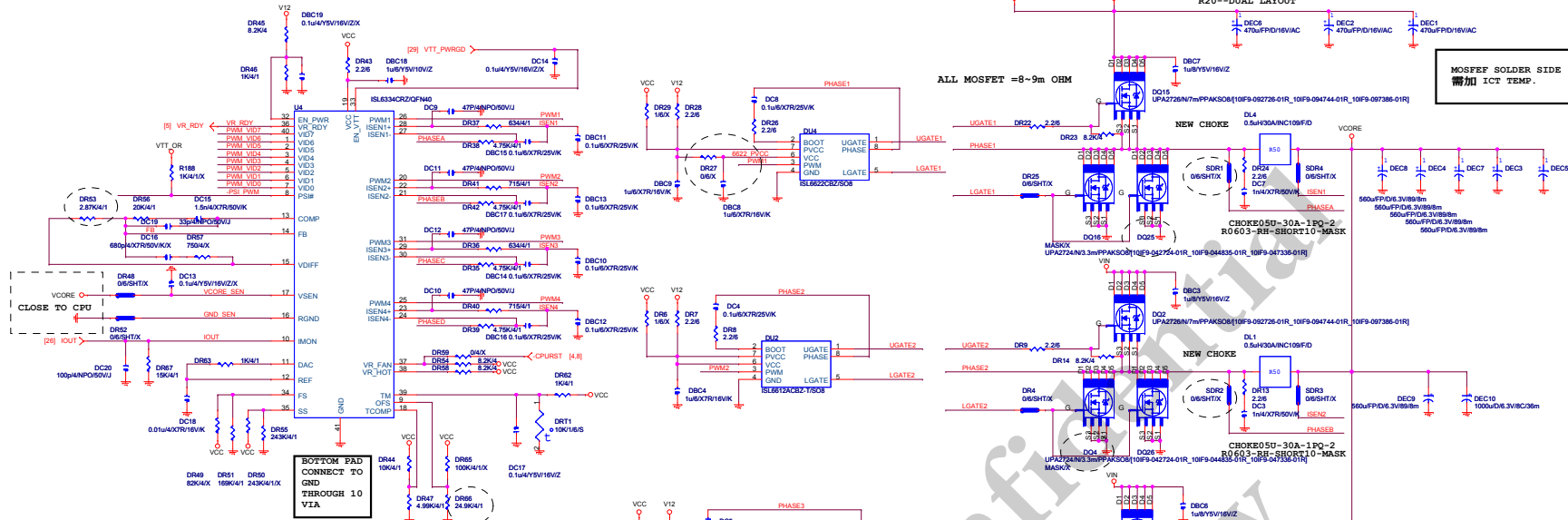

MOSFET SOLDER SIDE  
增加 ICT TEMP.

ALL MOSFET = 8-9m OHM

NEW CHOKE  
CHOK050-30A-1PQ-2  
R0603-RH-SHORT10-MASK

l=0.5uR(DL1)/DCR=1.1mΩ/C=0.1uF(DC24)  
L/DCR=BC=0.5u/1.05m=530.1u (R(DR87)\*4=75KΩ)  
因為ISL6327 OCP threshold is 85uA,  
所以一般我們將I<sub>sen</sub>設定為50uA,代入公式可得到I<sub>isen</sub> / 假設: IL=125A  
DCR=1.05mΩ I<sub>sen</sub>=50uA, I<sub>isen</sub>= (212A\*1.05mΩ)  
/(85uA\*4Phase)=654Ω (DR143), 那代表IL=212A 會OCP  
VDROOP=I<sub>avg</sub>\*R<sub>FB</sub>, 假設 =125A\*1mΩ=125mV, I<sub>avg</sub>=  
50uA, 可得到 = 125mV / 50uA = 2.5KΩ (DR98)

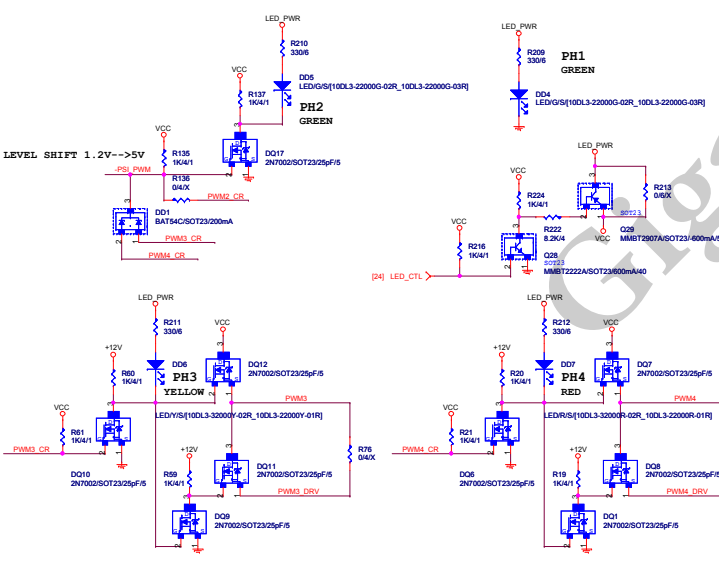

PHM PHASE CONTROL FIX WOLFDALDE/YORKFIELD -PSI ERROR ISSUE

	ITE8268 GPIO2	ITE8268 GPIO1	ITE8268 GPIO0
1 PHASE	L	L	L
2 PHASE	X	L	L
3 PHASE	X	X	L
4 PHASE	X	X	X

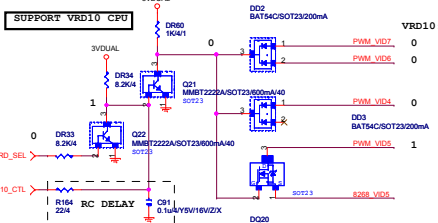
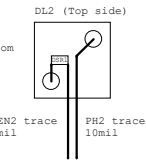
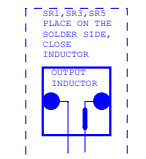
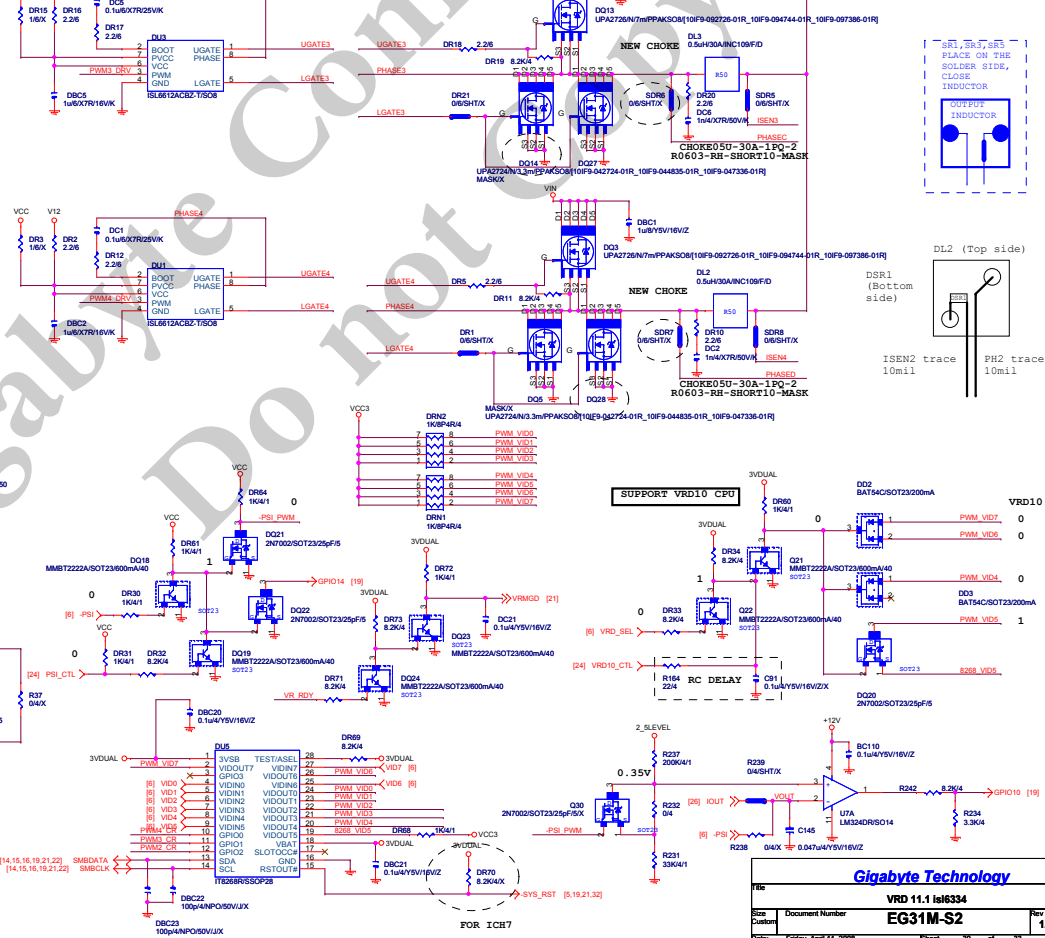

**Gigabyte Technology**

File: VRD 11.1 Isl6334  
 Document Number: EG31M-S2  
 Rev: 1.02

Date: Friday, April 11, 2008

# ATX POWER CONNECTOR

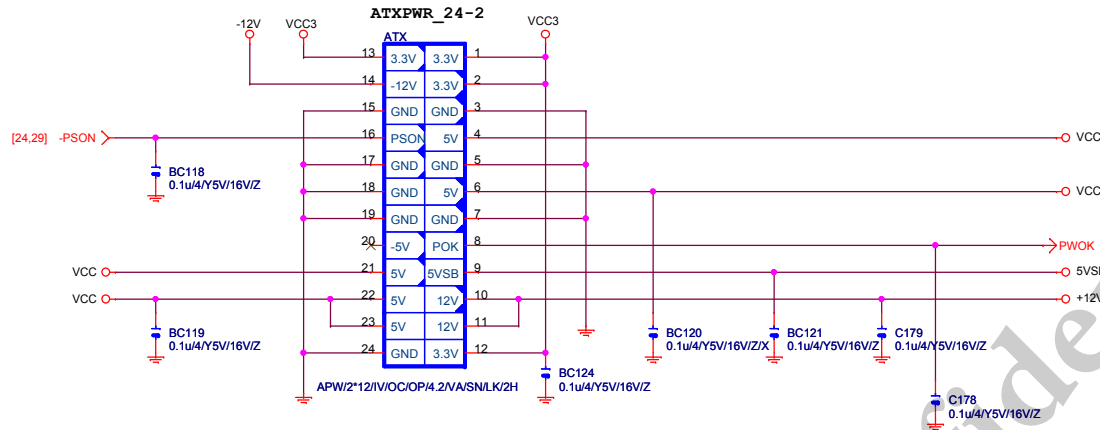

## FIX PWR AcBel (ATX-400C-A2ADB)

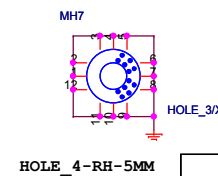
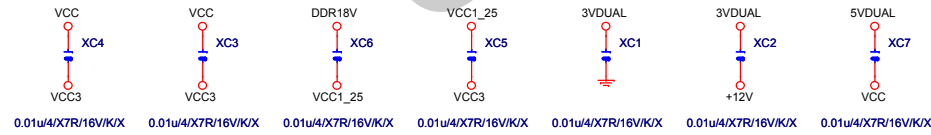
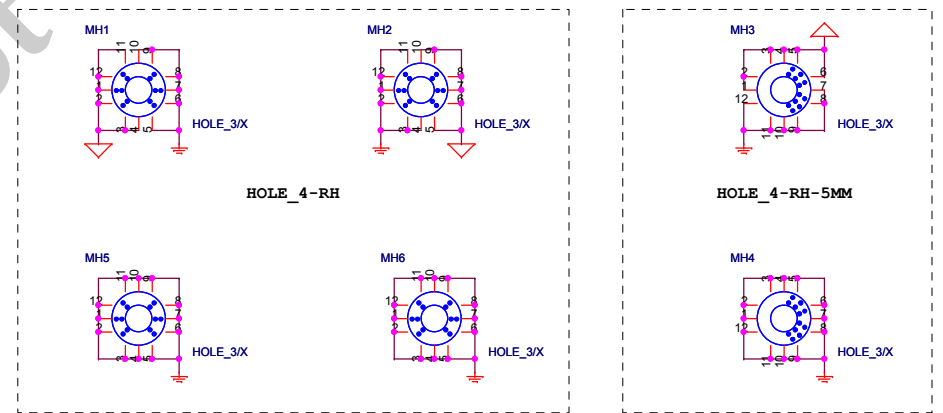
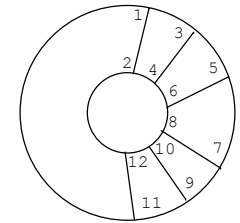
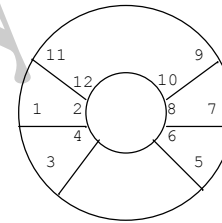
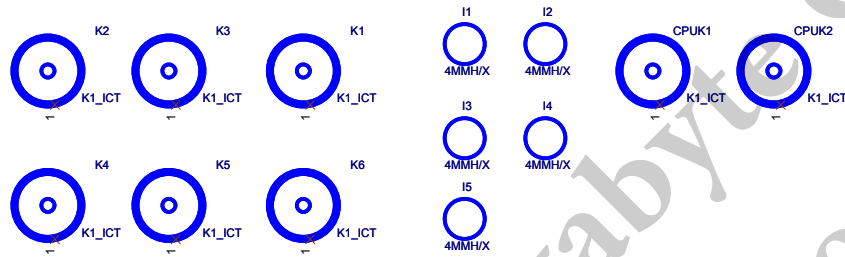
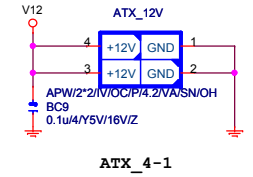
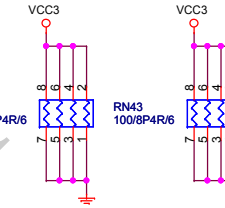

**Gigabyte Technology**

Title		
<b>ATX POWER CONNECTOR</b>		
Size	Document Number	Rev
B	<b>EG31M-S2</b>	<b>1.02</b>
Date:	Thursday, April 10, 2008	Sheet 31 of 33

**CPU SMART FAN SMART FAN**

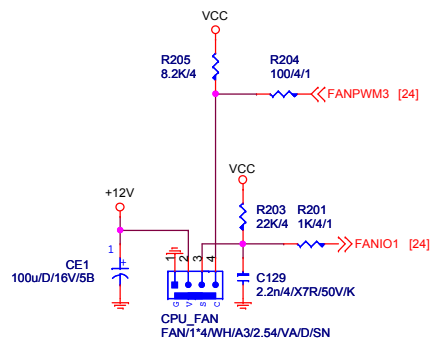

**PROCESSOR HOT**

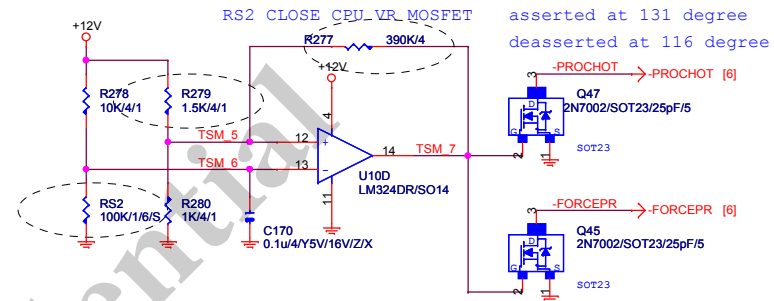

**INTEL FRONT PANEL**

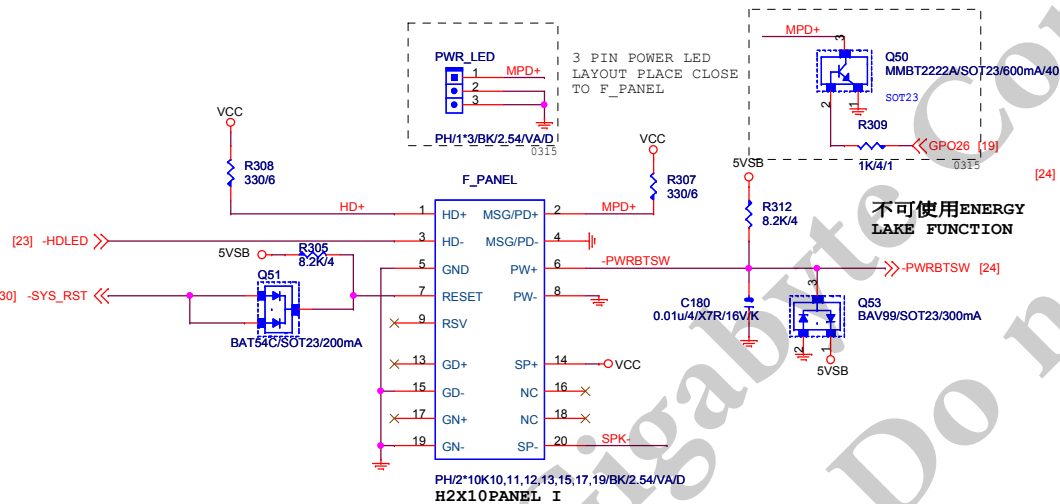

**SYS SMART FAN**

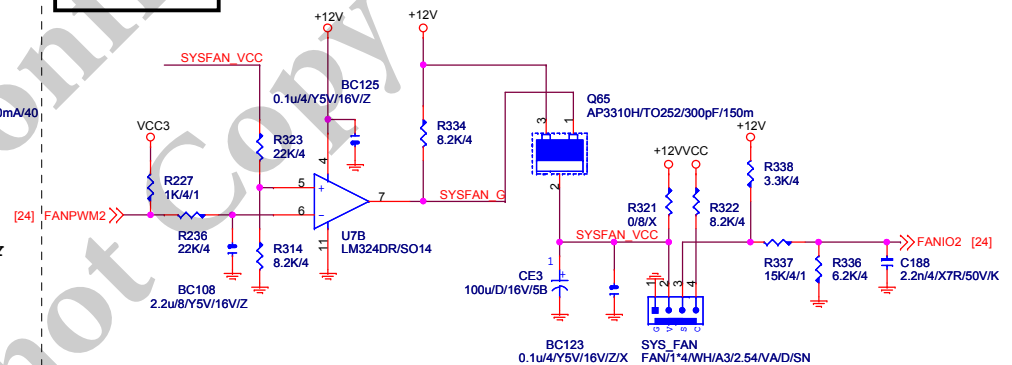

**BUZZER**

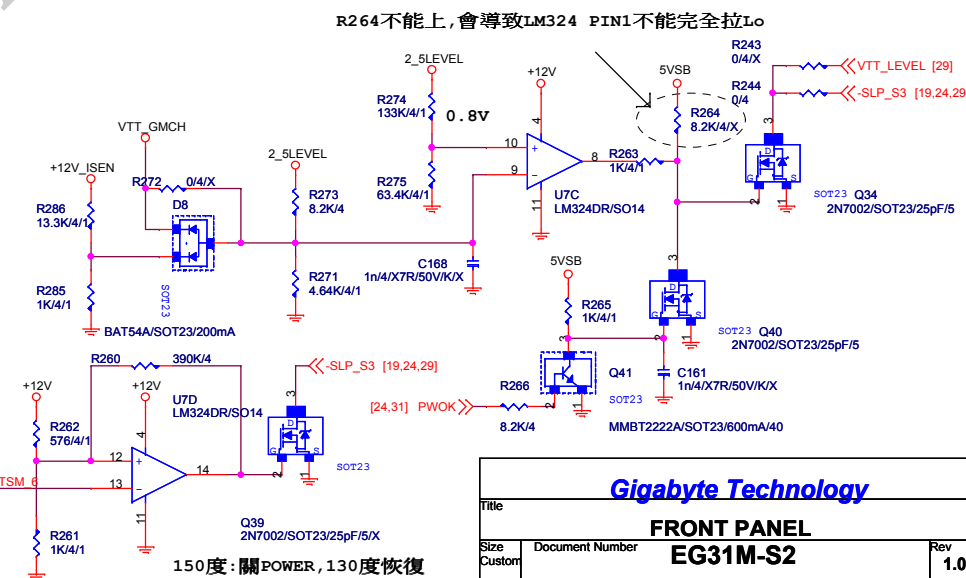
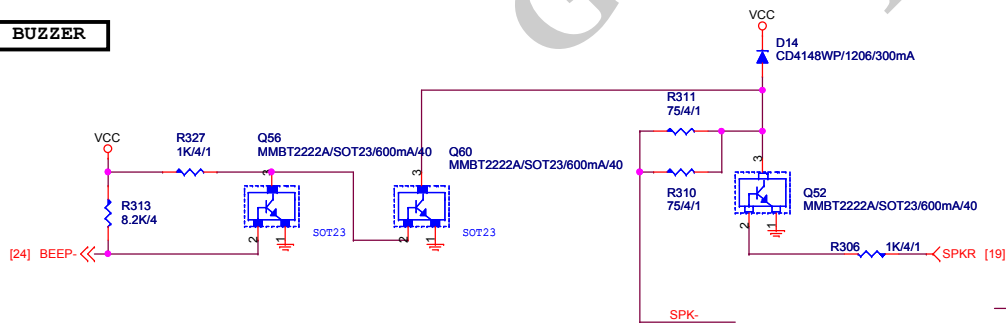

<b>Gigabyte Technology</b>		
<b>FRONT PANEL</b>		
<b>EG31M-S2</b>		
Size Custom	Document Number	Rev 1.02
Date: Thursday, April 10, 2008	Sheet 32	of 33



