

SHEET

TITLE

01	COVER SHEET
02	BOM & PCB MODIFY HISTORY
03	BLOCK DIAGRAM
04	CPU_LGA1155-A
05	CPU_LGA1155-B
06	CPU_LGA1155-C
07	DDR III CHANNEL A 1,2
08	DDR III CHANNEL B 1,2
09	PCH_FDI,DMI,USB,PCIE,NVRAM
10	PCH_DP,CLK BUFFER
11	PCH_HOST,SATA,PCI
12	PCH_GPIO,CTRL,AUDIO
13	PCH_PWR,GND
14	PCI EXPRESS*16 SLOT
15	PCI EXPRESS*4 SLOT
16	PCI SLOT1,2
17	ITE 8728 LPC IO
18	COM,KB_MS_USB,USB30_20
19	HWM,FAN CTRL,OV,-PROCHOT
20	DUAL BIOS
21	FP,FUSB,SPK,SATALED
22	Realtek ALC887-VD2
23	REAR AUDIO JACK
24	REALTEK RTL8111F-VL
25	DISCRETE POWER
26	ATX,CLK GEN
27	RT8120_CPU_VTT

SHEET

TITLE

28	VCORE ISL95836_1
29	VCORE ISL95836_2
30	RT8120_DDR POWER
31	LPT,TPM,M3 POWER
32	HDMI,DVI

Gigabyte Technology

Title			
Cover Sheet			
Size	Document Number	Rev	
Custom	GA-B75M-D3H	1.1	
Date:	Friday, June 08, 2012	Sheet	1 of 33

Model Name: GA-B75M-D3H

Revision 1.1

Circuit or PCB layout change

Component value change history

2012/06/01

Data	Change Item	Reason
2011/12/05	LAN Change Realtek RTL8111E	
2011/12/22	Modify to R0.2	
	ADD M3 Power	
2012/01/16	Modify to R1.0	
2012/04/26	FIX ISL95836 OVP ISSUE	9MB75MD3H-00-10C
	Modify R23, R22 (75K/15K)	
2012/05/28	Update to Rev1.1	
	F.B. 60 Ohm 0603 down size to 0402	
	ATX12V 2x2 -> 2x4	
	PWOK ADD 4.7u MLCC	
2012/05/31	PWOK ADD 0ohm Resistance	
2012/06/01	Update ATX Footprint "ATXPWR_24-6"	

DATE	Change Item	Reason

# BLOCK DIAGRAM

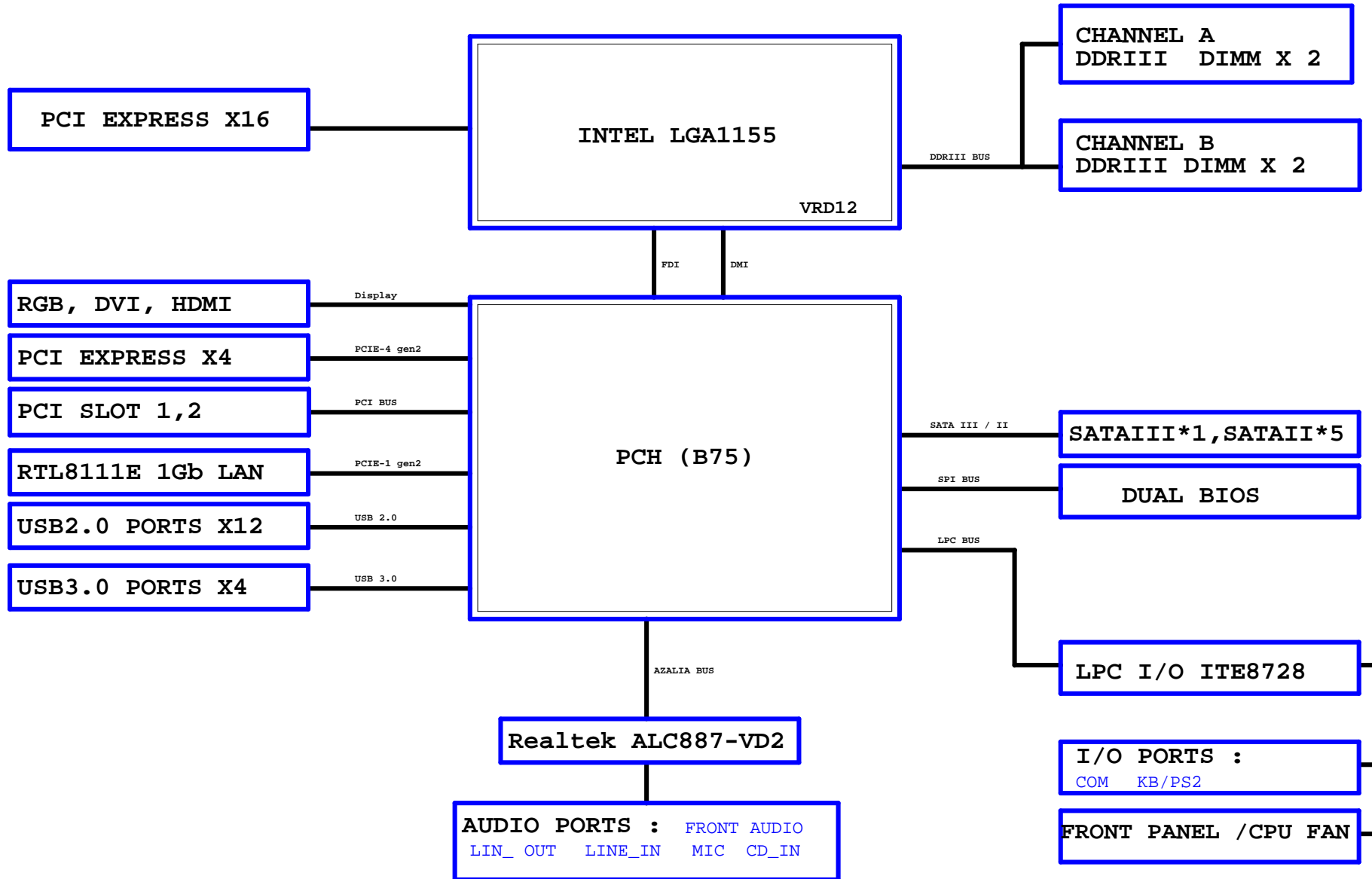

LGA1155 (E)

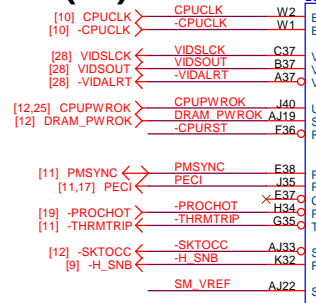
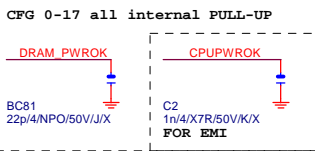
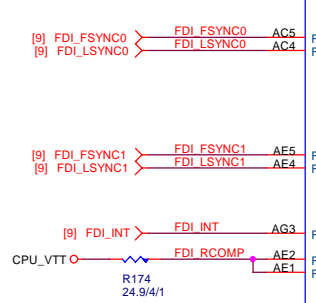

Table with columns CFG#, H, L, and NOTE. It lists configurations for RSV, NOR, and PCIE. Includes a section for PCIE CONFIG with values for 1X16, 2X8, and X8, X4, X4.



LGA1155 (D)



LGA1155 (C)

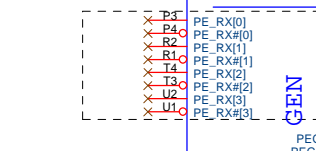
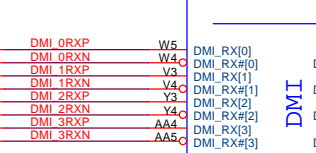
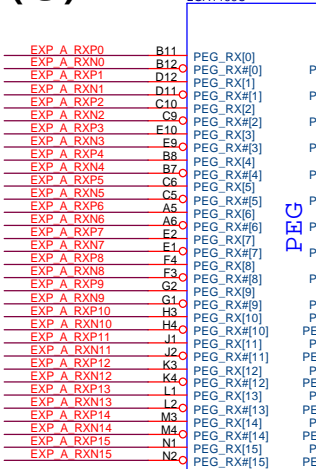

-CPURST

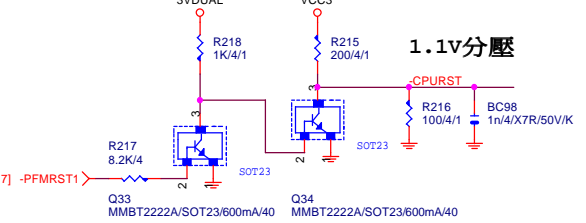

LGA1155C

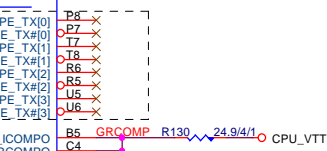
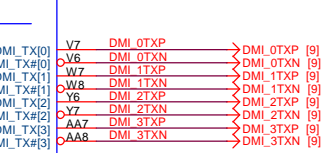
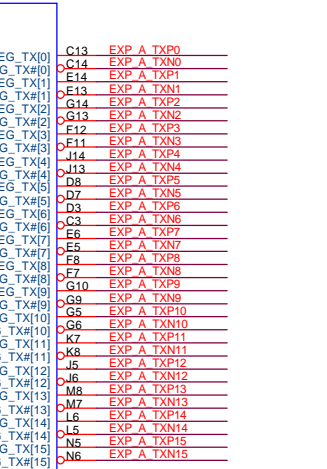

CPU PU/PD

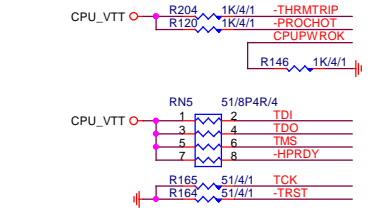

CPU SVID

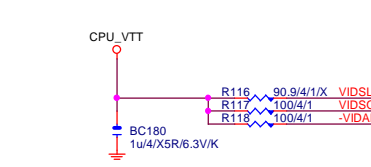

SM REF

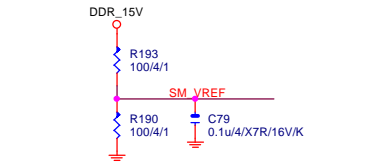

LGA1155 (A)

LGA1155A

MAAA0	AV27	SA_MA[0]	SA_DQS[0]	AK3	DQSA0	
MAAA1	AY24	SA_MA[1]	SA_DQS#0	AK2	-DQSA0	
MAAA2	AW24	SA_MA[2]				
MAAA3	AW23	SA_MA[3]				
MAAA4	AV23	SA_MA[4]	SA_DQ[0]	AJ3	MDA0	
MAAA5	AT24	SA_MA[5]	SA_DQ[1]	AL3	MDA1	
MAAA6	AT24	SA_MA[5]	SA_DQ[1]	AL3	MDA2	
MAAA7	AU22	SA_MA[6]	SA_DQ[2]	AL4	MDA3	
MAAA8	AV22	SA_MA[8]	SA_DQ[3]	AJ2	MDA4	
MAAA9	AT22	SA_MA[9]	SA_DQ[5]	AL1	MDA5	
MAAA10	AV28	SA_MA[10]	SA_DQ[6]	AL2	MDA6	
MAAA11	AU21	SA_MA[11]	SA_DQ[7]	AL1	MDA7	
MAAA12	AT21	SA_MA[11]				
MAAA13	AW32	SA_MA[12]	SA_DQS[1]	AP3	DQSA1	
MAAA14	AU20	SA_MA[14]	SA_DQS#1	AP2	-DQSA1	
MAAA15	AT20	SA_MA[15]				
[7]	-SWEA	AW29	SA_WE#	AN1	MDA8	
[7]	-SCASA	AV30	SA_CAS#	AN4	MDA9	
[7]	-SRASA	AU28	SA_RAS#	AR3	MDA10	
[7]	SBA0	AV29	SA_BS[0]	AN2	MDA11	
[7]	SBA1	AW28	SA_BS[1]	AN3	MDA12	
[7]	SBA2	AV20	SA_BS[2]	AN2	MDA13	
[7]	-CSA0	AU29	SA_CS#0	AN2	MDA14	
[7]	-CSA1	AV24	SA_CS#1	AN3	MDA15	
[7]	-CSA2	AW30	SA_CS#2	AR1	MDA15	
[7]	-CSA3	AU33	SA_CS#3	AW4	DQSA2	
[7]	-CSA3	AU33	SA_CS#3	AV4	-DQSA2	
[7]	CKEA0	AV19	SA_CKE[0]	AV2	MDA16	
[7]	CKEA1	AT19	SA_CKE[1]	AW3	MDA17	
[7]	CKEA2	AU18	SA_CKE[2]	AV5	MDA18	
[7]	CKEA3	AV18	SA_CKE[3]	AW5	MDA19	
[7]	CKEA3	AV18	SA_CKE[3]	AU2	MDA20	
[7]	CKEA3	AV18	SA_CKE[3]	AU2	MDA21	
[7]	CKEA3	AV18	SA_CKE[3]	AU5	MDA22	
[7]	CKEA3	AV18	SA_CKE[3]	AY5	MDA23	
[7]	CKEA3	AV18	SA_CKE[3]	AV8	DQSA3	
[7]	CKEA3	AV18	SA_CKE[3]	AW8	-DQSA3	
[7]	DCLKA0	AY25	SA_CK[0]	AY7	MDA24	
[7]	-DCLKA0	AW25	SA_CK#0	AU7	MDA25	
[7]	DCLKA1	AU24	SA_CK[1]	AV9	MDA26	
[7]	-DCLKA1	AU25	SA_CK#1	AU9	MDA27	
[7]	DCLKA2	AW27	SA_CK[2]	AV7	MDA28	
[7]	-DCLKA2	AY27	SA_CK#2	AW7	MDA29	
[7]	DCLKA3	AV26	SA_CK[3]	AW9	MDA30	
[7]	-DCLKA3	AW26	SA_CK#3	AY9	MDA31	
[7]	-DCLKA3	AW26	SA_CK#3	AV37	DQSA4	
[7]	-DCLKA3	AW26	SA_CK#3	AV36	-DQSA4	
[7,8]	-DDR3_RST	AW18	SM_DRAMRST#	SA_DQ[32]	AU35	MDA32
[7]	DCLKA0	AY25	SA_CK[0]	SA_DQ[33]	AW37	MDA33
[7]	-DCLKA0	AW25	SA_CK#0	AU39	MDA34	
[7]	DCLKA1	AU24	SA_CK[1]	SA_DQ[34]	AU36	MDA35
[7]	-DCLKA1	AU25	SA_CK#1	SA_DQ[35]	AW35	MDA36
[7]	DCLKA2	AW27	SA_CK[2]	SA_DQ[36]	AW35	MDA36
[7]	-DCLKA2	AY27	SA_CK#2	SA_DQ[37]	AY36	MDA37
[7]	DCLKA3	AV26	SA_CK[3]	SA_DQ[38]	AU38	MDA38
[7]	-DCLKA3	AW26	SA_CK#3	SA_DQ[39]	AU37	MDA39
[7]	-DCLKA3	AW26	SA_CK#3	SA_DQS[5]	AP38	DQSA5
[7]	-DCLKA3	AW26	SA_CK#3	SA_DQS#5	AP39	-DQSA5
[7]	-DCLKA3	AW26	SA_CK#3	SA_DQ[40]	AR40	MDA40
[7]	-DCLKA3	AW26	SA_CK#3	SA_DQ[41]	AR37	MDA41
[7]	-DCLKA3	AW26	SA_CK#3	SA_DQ[42]	AN38	MDA42
[7]	-DCLKA3	AW26	SA_CK#3	SA_DQ[43]	AN37	MDA43
[7]	-DCLKA3	AW26	SA_CK#3	SA_DQ[44]	AR39	MDA44
[7]	-DCLKA3	AW26	SA_CK#3	SA_DQ[45]	AR38	MDA45
[7]	-DCLKA3	AW26	SA_CK#3	SA_DQ[46]	AN39	MDA46
[7]	-DCLKA3	AW26	SA_CK#3	SA_DQ[47]	AN40	MDA47
[7]	-DCLKA3	AW26	SA_CK#3	SA_DQS[6]	AK38	DQSA6
[7]	-DCLKA3	AW26	SA_CK#3	SA_DQS#6	AK39	-DQSA6
[7]	-DCLKA3	AW26	SA_CK#3	SA_DQ[48]	AL40	MDA48
[7]	-DCLKA3	AW26	SA_CK#3	SA_DQ[49]	AL37	MDA49
[7]	-DCLKA3	AW26	SA_CK#3	SA_DQ[50]	AJ38	MDA50
[7]	-DCLKA3	AW26	SA_CK#3	SA_DQ[51]	AJ37	MDA51
[7]	-DCLKA3	AW26	SA_CK#3	SA_DQ[52]	AL39	MDA52
[7]	-DCLKA3	AW26	SA_CK#3	SA_DQ[53]	AL38	MDA53
[7]	-DCLKA3	AW26	SA_CK#3	SA_DQ[54]	AJ39	MDA54
[7]	-DCLKA3	AW26	SA_CK#3	SA_DQ[55]	AL40	MDA55
[7]	-DCLKA3	AW26	SA_CK#3	SA_DQS[7]	AF38	DQSA7
[7]	-DCLKA3	AW26	SA_CK#3	SA_DQS#7	AF39	-DQSA7
[7]	-DCLKA3	AW26	SA_CK#3	SA_DQ[56]	AG40	MDA56
[7]	-DCLKA3	AW26	SA_CK#3	SA_DQ[57]	AG37	MDA57
[7]	-DCLKA3	AW26	SA_CK#3	SA_DQ[58]	AE38	MDA58
[7]	-DCLKA3	AW26	SA_CK#3	SA_DQ[59]	AE37	MDA59
[7]	-DCLKA3	AW26	SA_CK#3	SA_DQ[60]	AG39	MDA60
[7]	-DCLKA3	AW26	SA_CK#3	SA_DQ[61]	AE38	MDA61
[7]	-DCLKA3	AW26	SA_CK#3	SA_DQ[62]	AE39	MDA62
[7]	-DCLKA3	AW26	SA_CK#3	SA_DQ[63]	AE40	MDA63

DDR\_0

1 OF 10

LGA1155[10SC1-F01155-21R\_10SC1-F01155-22R]

LGA1155 (B)

LGA1155B

MAA0	AK24	SB_MA[0]	SB_DQS[0]	AH7	DQSB0	
MAA1	AM20	SB_MA[1]	SB_DQS#0	AH6	-DQSB0	
MAA2	AM19	SB_MA[2]				
MAA3	AK18	SB_MA[3]				
MAA4	AP19	SB_MA[4]	SB_DQ[0]	AG7	MDB0	
MAA5	AM18	SB_MA[5]	SB_DQ[1]	AG8	MDB1	
MAA6	AM18	SB_MA[5]	SB_DQ[1]	AG8	MDB2	
MAA7	AL18	SB_MA[6]	SB_DQ[2]	AG8	MDB3	
MAA8	AN18	SB_MA[7]	SB_DQ[3]	AJ5	MDB4	
MAA9	AY17	SB_MA[9]	SB_DQ[5]	AG6	MDB5	
MAA10	AN23	SB_MA[10]	SB_DQ[6]	AJ6	MDB7	
MAA11	AU17	SB_MA[11]	SB_DQ[7]	AJ7	MDB7	
MAA12	AT18	SB_MA[11]				
MAA13	AR26	SB_MA[12]	SB_DQS[1]	AM8	DQSB1	
MAA14	AY16	SB_MA[14]	SB_DQS#1	AL8	-DQSB1	
MAA15	AV16	SB_MA[15]				
[8]	-SWEB	-SWEB	SB_WE#	AL7	MDB8	
[8]	-SCASB	-SCASB	SB_CAS#	AM7	MDB9	
[8]	-SRASB	-SRASB	SB_RAS#	AM10	MDB10	
[8]	SBA0	SBA0	SB_BS[0]	SB_DQ[10]	AM10	MDB10
[8]	SBA1	SBA1	SB_BS[1]	SB_DQ[11]	AL10	MDB11
[8]	SBA2	SBA2	SB_BS[2]	SB_DQ[12]	AM6	MDB13
[8]	-CSB0	-CSB0	SB_CS#0	SB_DQ[13]	AL9	MDB14
[8]	-CSB1	-CSB1	SB_CS#1	SB_DQ[15]	AM9	MDB15
[8]	-CSB2	-CSB2	SB_CS#2	SB_DQ[15]	AM9	MDB15
[8]	-CSB3	-CSB3	SB_CS#3	SB_DQ[15]	AM9	MDB15
[8]	CKEB0	AU16	SB_CKE[0]	AP7	MDB16	
[8]	CKEB1	AY15	SB_CKE[1]	AR7	MDB17	
[8]	CKEB2	AW15	SB_CKE[2]	AP10	MDB18	
[8]	CKEB3	AV15	SB_CKE[3]	AR10	MDB19	
[8]	CKEB3	AV15	SB_CKE[3]	AP6	MDB20	
[8]	CKEB3	AV15	SB_CKE[3]	AR6	MDB21	
[8]	CKEB3	AV15	SB_CKE[3]	AP9	MDB22	
[8]	CKEB3	AV15	SB_CKE[3]	AR9	MDB23	
[8]	CKEB3	AV15	SB_CKE[3]	AN13	DQSB3	
[8]	CKEB3	AV15	SB_CKE[3]	AN12	-DQSB3	
[8]	CKEB3	AV15	SB_CKE[3]	AM12	MDB24	
[8]	CKEB3	AV15	SB_CKE[3]	AM13	MDB25	
[8]	CKEB3	AV15	SB_CKE[3]	AR13	MDB26	
[8]	CKEB3	AV15	SB_CKE[3]	AP13	MDB27	
[8]	CKEB3	AV15	SB_CKE[3]	AL12	MDB28	
[8]	CKEB3	AV15	SB_CKE[3]	AL13	MDB29	
[8]	CKEB3	AV15	SB_CKE[3]	AR12	MDB30	
[8]	CKEB3	AV15	SB_CKE[3]	AP12	MDB31	
[8]	CKEB3	AV15	SB_CKE[3]	AN29	DQSB4	
[8]	CKEB3	AV15	SB_CKE[3]	AN28	-DQSB4	
[8]	CKEB3	AV15	SB_CKE[3]	AR28	MDB32	
[8]	CKEB3	AV15	SB_CKE[3]	AR29	MDB33	
[8]	CKEB3	AV15	SB_CKE[3]	AL28	MDB34	
[8]	CKEB3	AV15	SB_CKE[3]	AL29	MDB35	
[8]	CKEB3	AV15	SB_CKE[3]	AP28	MDB36	
[8]	CKEB3	AV15	SB_CKE[3]	AP29	MDB37	
[8]	CKEB3	AV15	SB_CKE[3]	AM28	MDB38	
[8]	CKEB3	AV15	SB_CKE[3]	AM29	MDB39	
[8]	CKEB3	AV15	SB_CKE[3]	AP33	DQSB5	
[8]	CKEB3	AV15	SB_CKE[3]	AR33	-DQSB5	
[8]	CKEB3	AV15	SB_CKE[3]	AP32	MDB40	
[8]	CKEB3	AV15	SB_CKE[3]	AP31	MDB41	
[8]	CKEB3	AV15	SB_CKE[3]	AP35	MDB42	
[8]	CKEB3	AV15	SB_CKE[3]	AP34	MDB43	
[8]	CKEB3	AV15	SB_CKE[3]	AR32	MDB44	
[8]	CKEB3	AV15	SB_CKE[3]	AR31	MDB45	
[8]	CKEB3	AV15	SB_CKE[3]	AR35	MDB46	
[8]	CKEB3	AV15	SB_CKE[3]	AR34	MDB47	
[8]	CKEB3	AV15	SB_CKE[3]	AL33	DQSB6	
[8]	CKEB3	AV15	SB_CKE[3]	AM33	-DQSB6	
[8]	CKEB3	AV15	SB_CKE[3]	AM32	MDB48	
[8]	CKEB3	AV15	SB_CKE[3]	AM31	MDB49	
[8]	CKEB3	AV15	SB_CKE[3]	AL35	MDB50	
[8]	CKEB3	AV15	SB_CKE[3]	AM34	MDB51	
[8]	CKEB3	AV15	SB_CKE[3]	AM34	MDB52	
[8]	CKEB3	AV15	SB_CKE[3]	AL31	MDB53	
[8]	CKEB3	AV15	SB_CKE[3]	AM35	MDB54	
[8]	CKEB3	AV15	SB_CKE[3]	AL34	MDB55	
[8]	CKEB3	AV15	SB_CKE[3]	AG35	DQSB7	
[8]	CKEB3	AV15	SB_CKE[3]	AG34	-DQSB7	
[8]	CKEB3	AV15	SB_CKE[3]	AH35	MDB56	
[8]	CKEB3	AV15	SB_CKE[3]	AH34	MDB57	
[8]	CKEB3	AV15	SB_CKE[3]	AE34	MDB58	
[8]	CKEB3	AV15	SB_CKE[3]	AE35	MDB59	
[8]	CKEB3	AV15	SB_CKE[3]	AJ35	MDB60	
[8]	CKEB3	AV15	SB_CKE[3]	AJ34	MDB61	
[8]	CKEB3	AV15	SB_CKE[3]	AF33	MDB62	
[8]	CKEB3	AV15	SB_CKE[3]	AF35	MDB63	

DDR\_1

2 OF 10

LGA1155[10SC1-F01155-21R\_10SC1-F01155-22R]

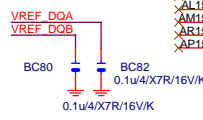

LGA1155 (CR)

CR CPU RETENTION X

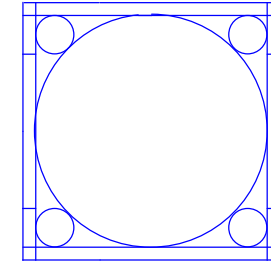

LGA1155\_P



ILM\_BP/1156/CSP/ILM\_BP/1156/CSP/12KRC-0F0001-05R\_12KRC-0F0001-31R]

**Gigabyte Technology**

Title		
CPU LGA1156-B		
Size	Document Number	Rev
Custom	<b>GA-B75M-D3H</b>	<b>1.1</b>
Date:	Friday, June 08, 2012	Sheet 5 of 33

**LGA1155 (F, G, H)**

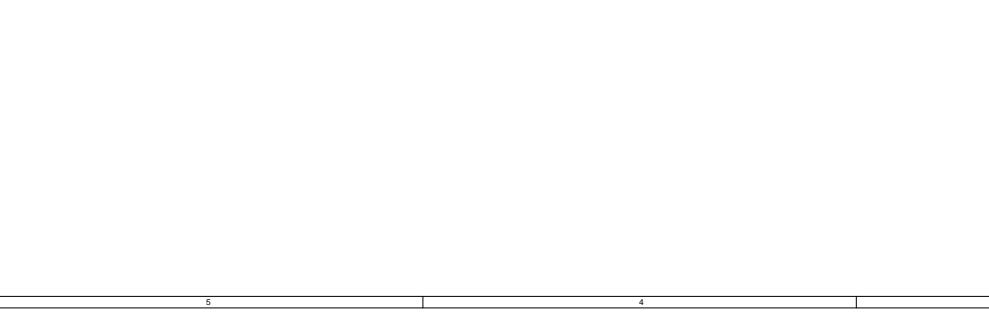
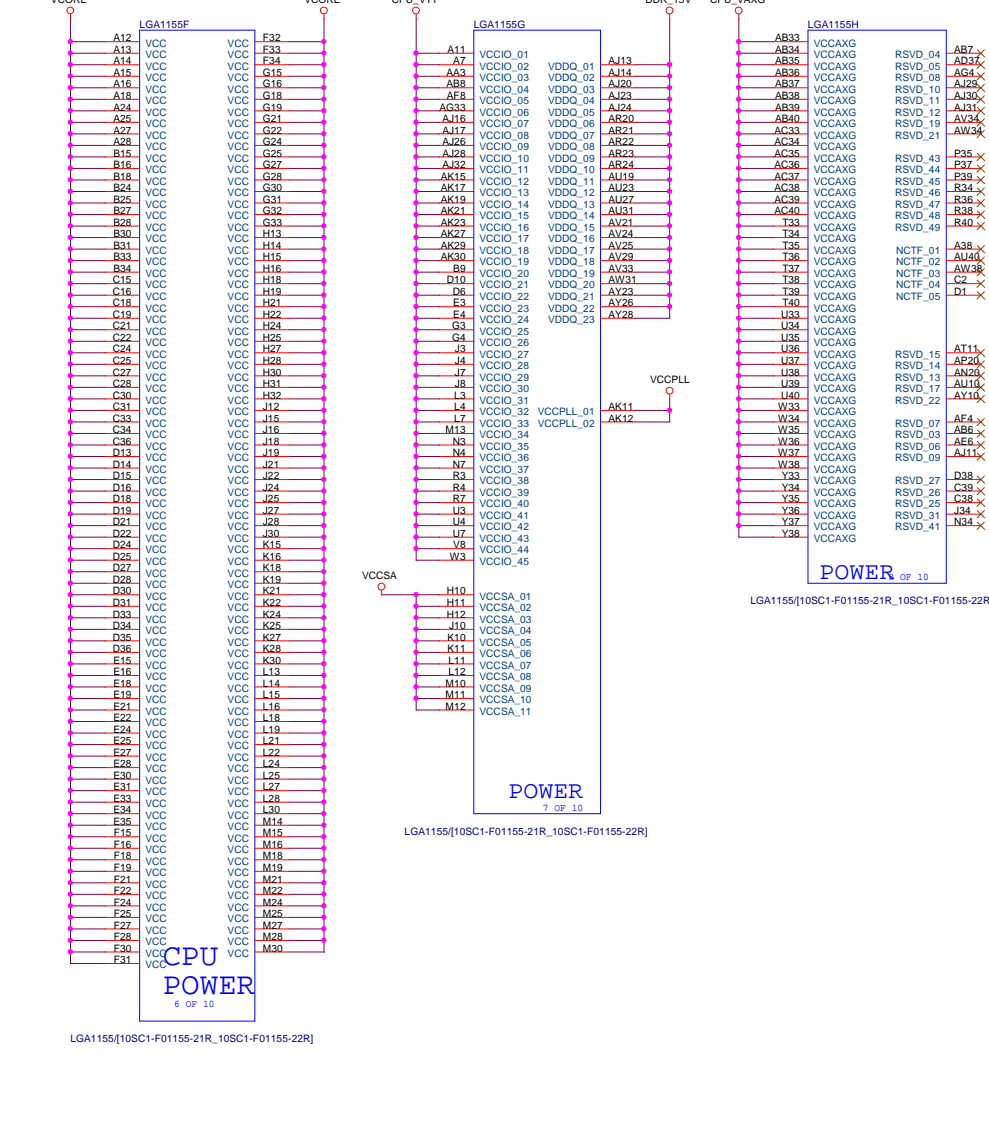

**LGA1155 (I, J)**

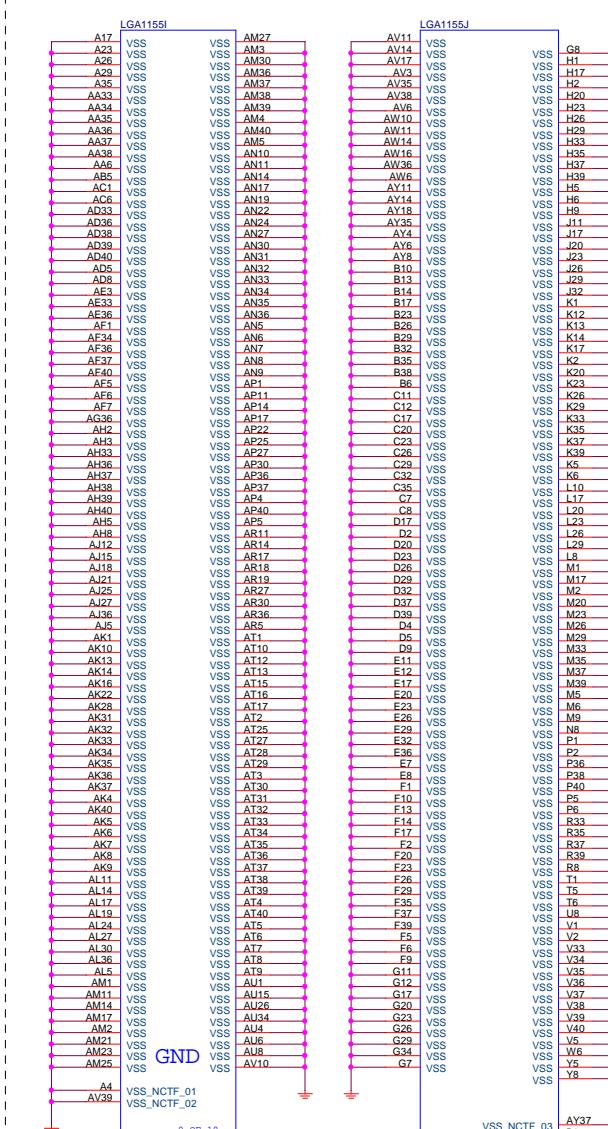

**CAP**

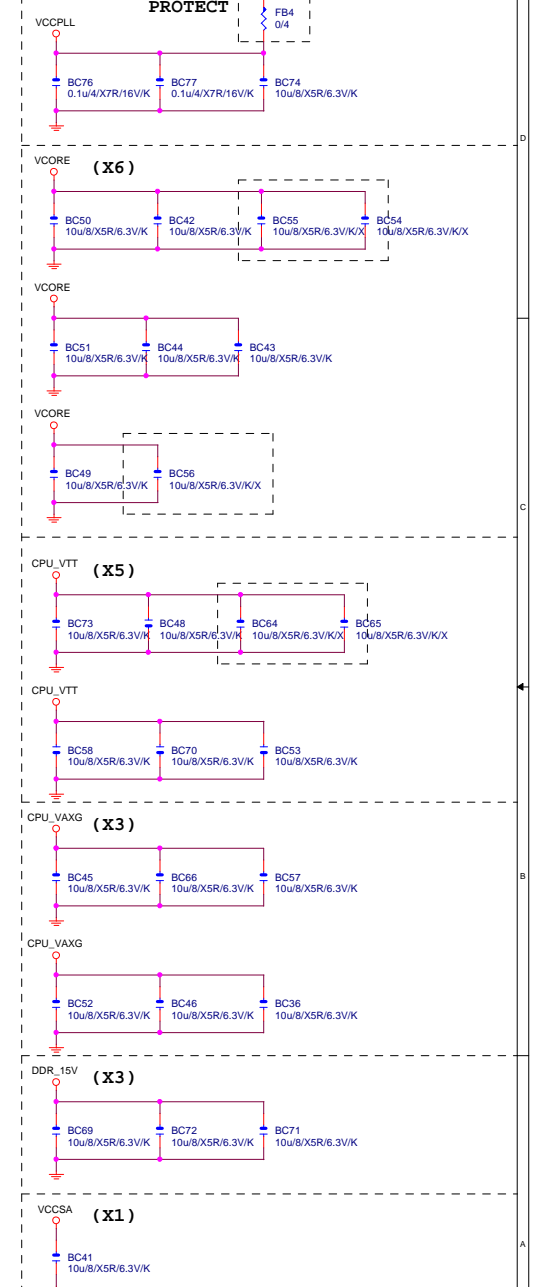

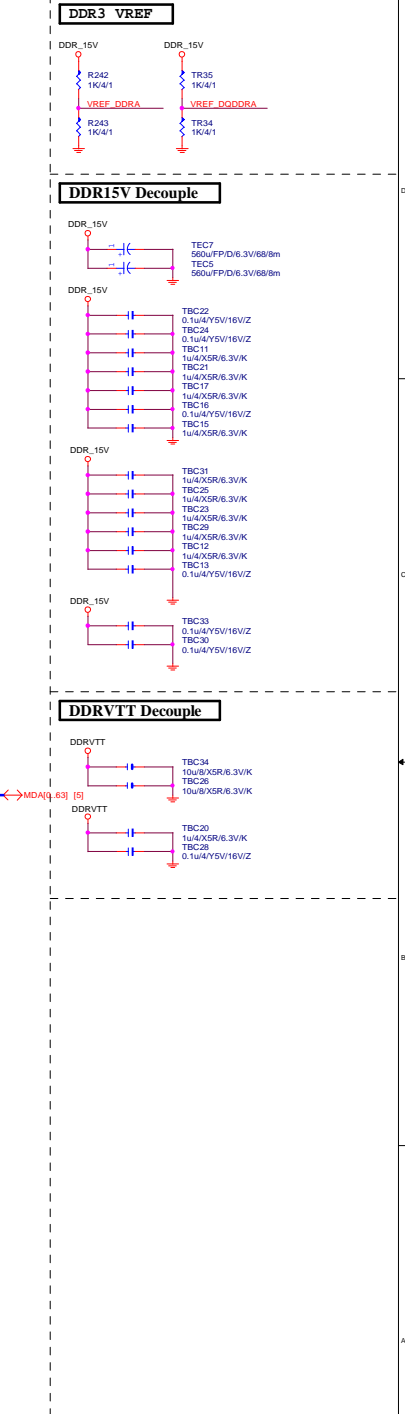
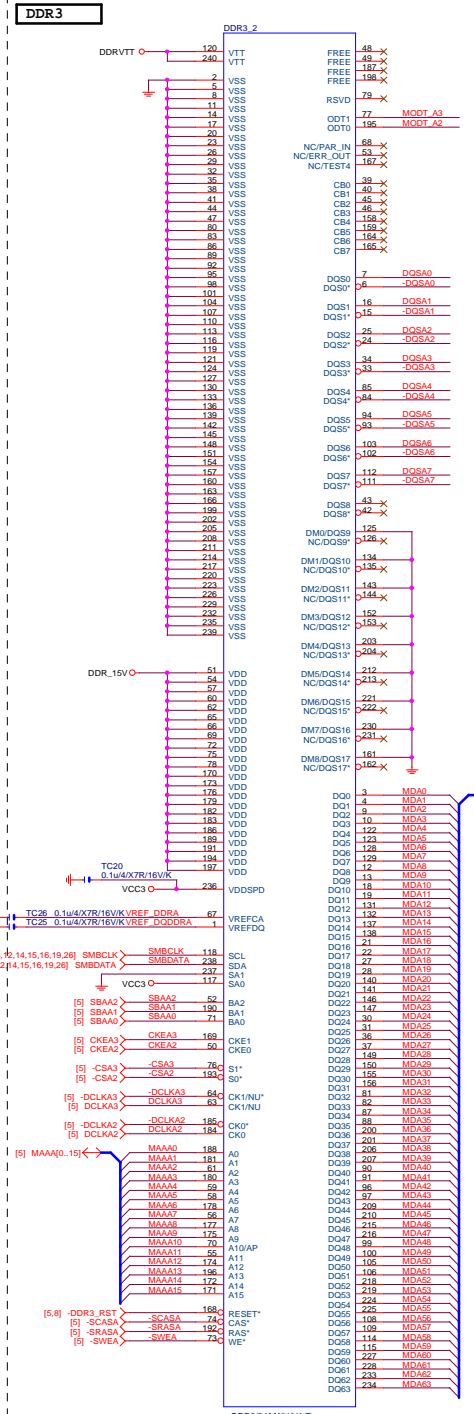
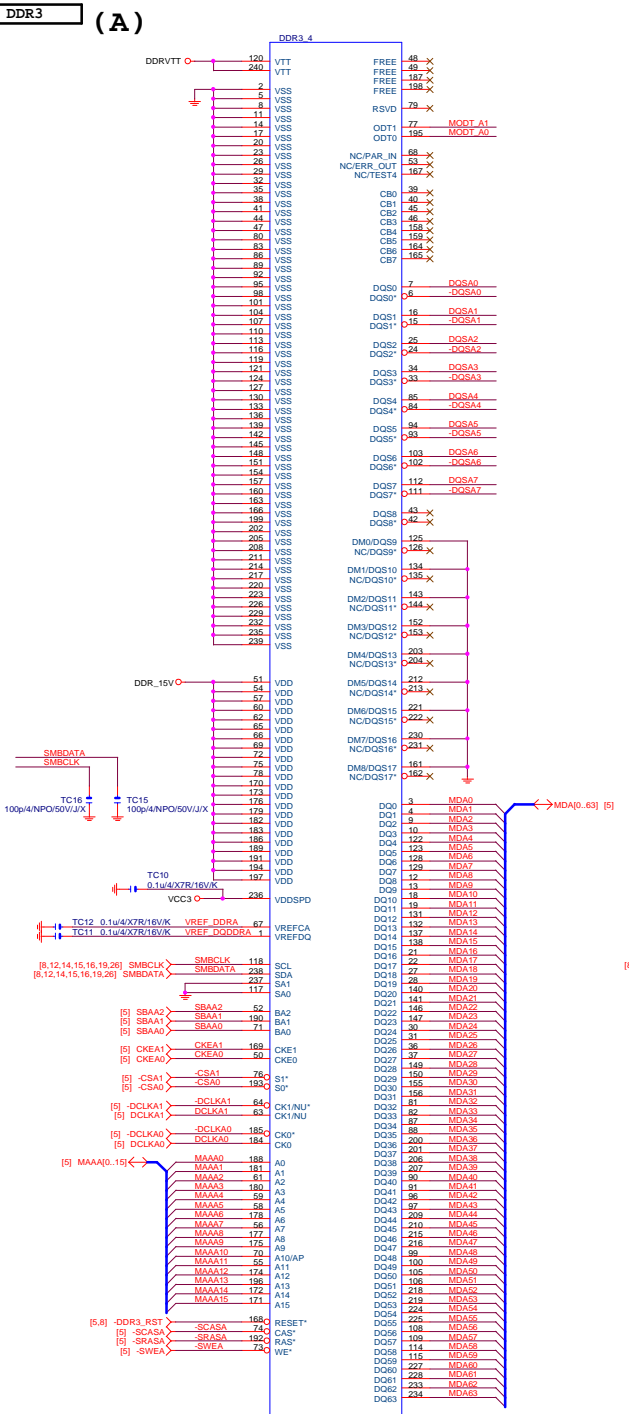



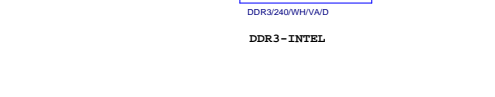
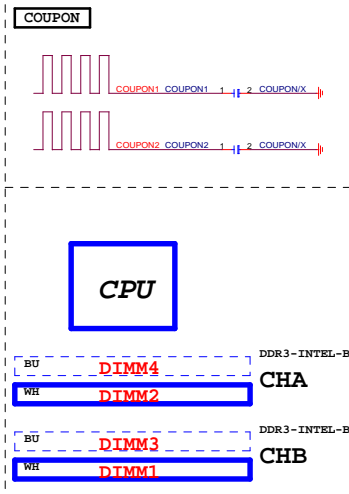
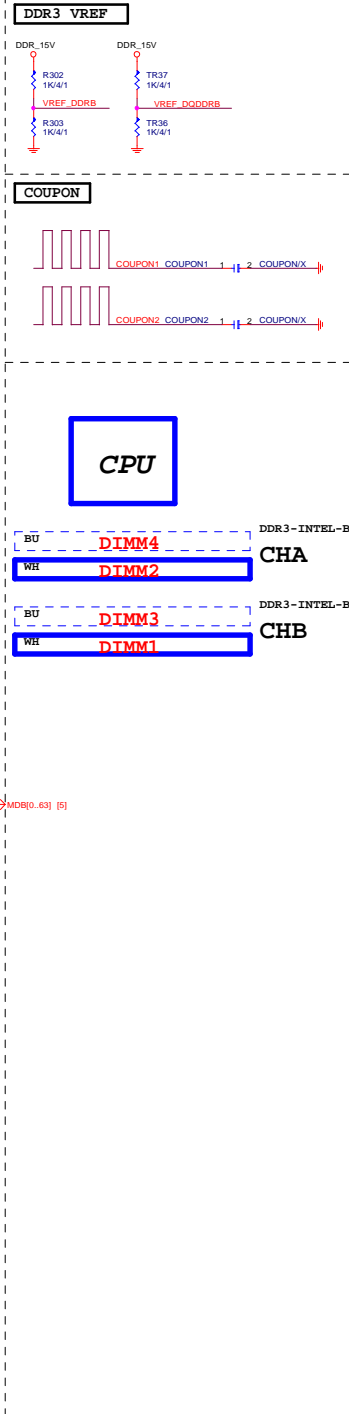
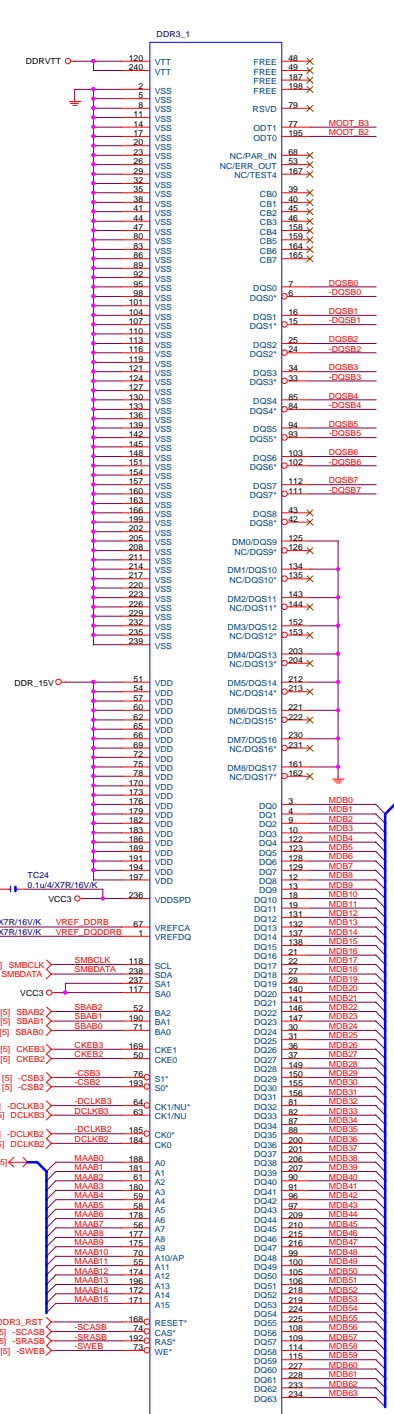
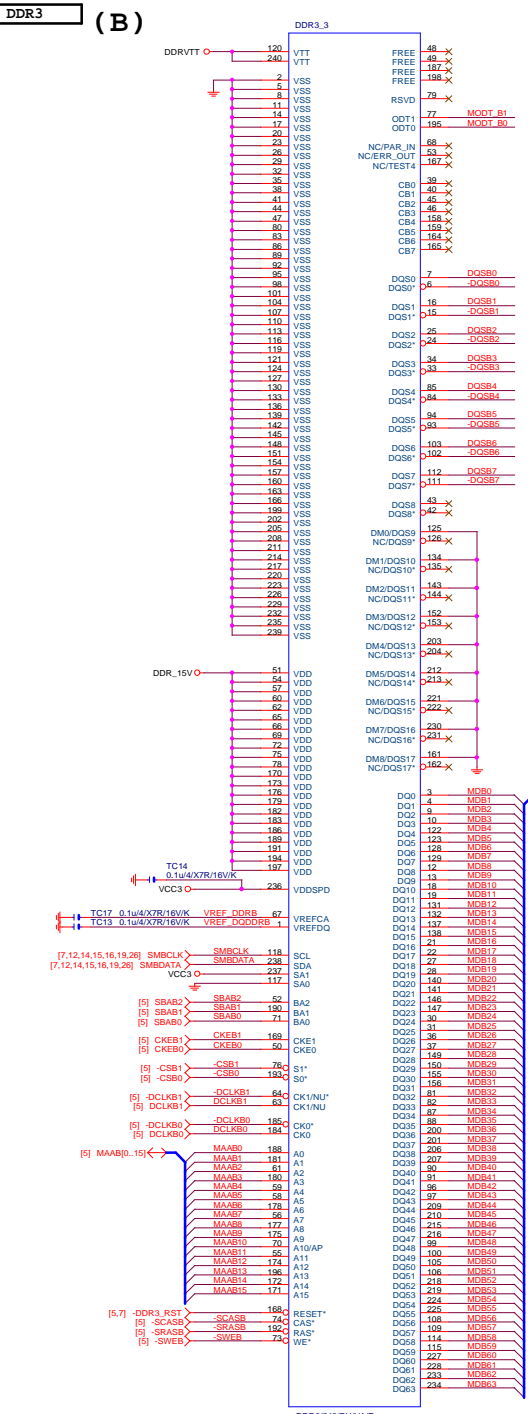

**Gigabyte Technology**

File: **DDR3 CHANNEL B**

Size: **GA-B75M-D3H**

Rev: **1.1**

Date: Sheet: 1 of 33



**PCH (B)**

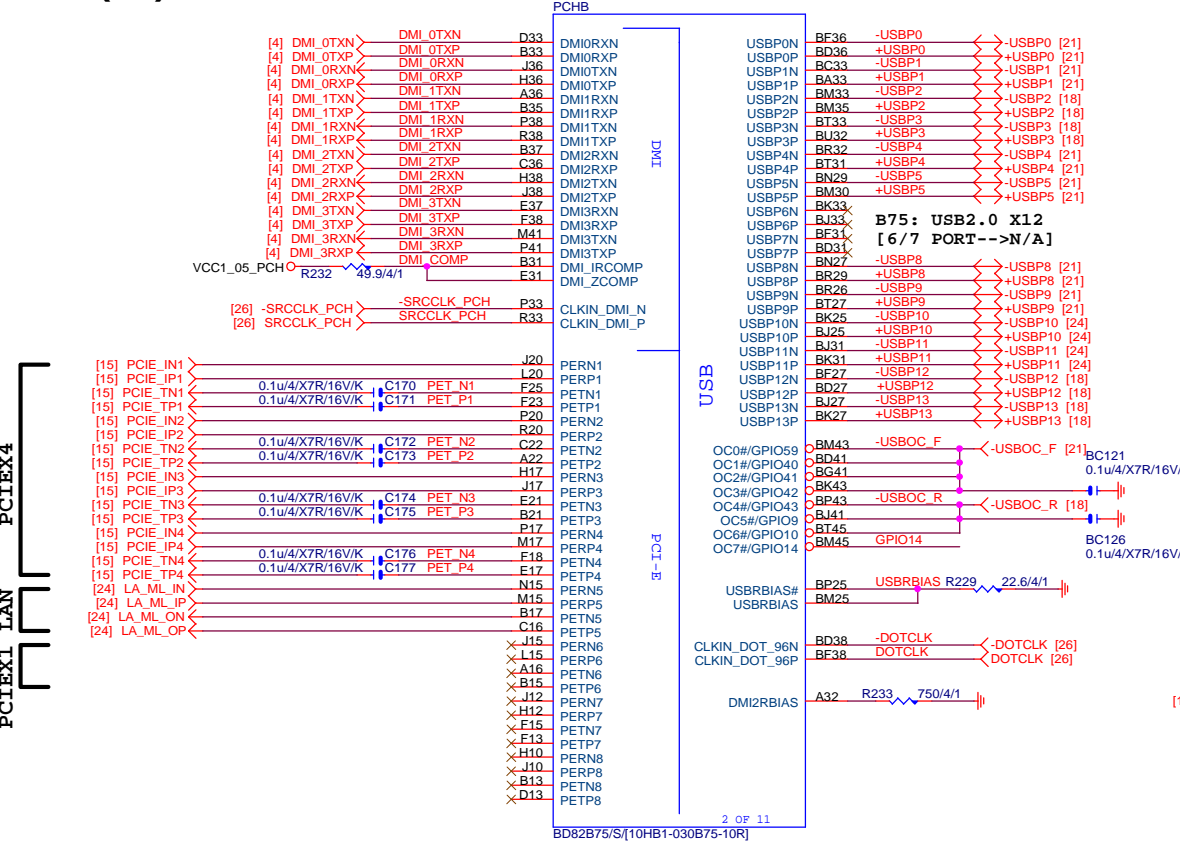

**PCH (G)**

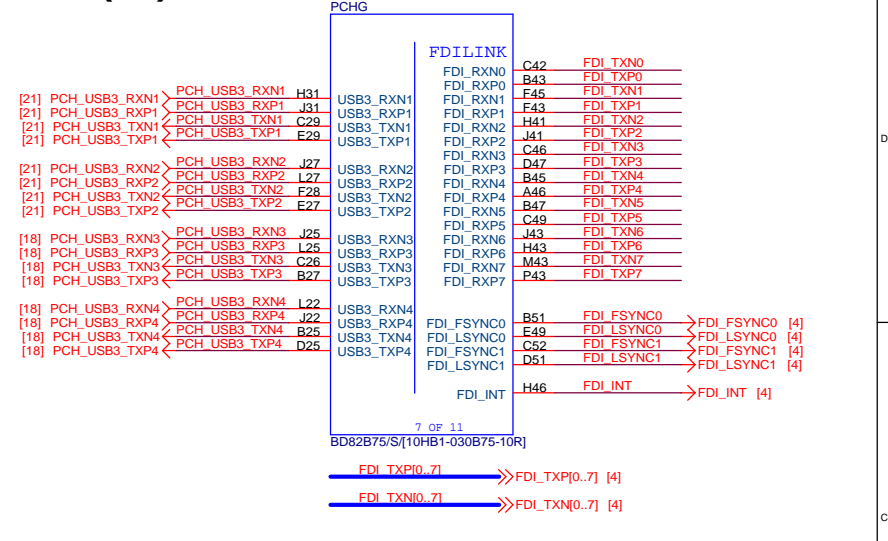

**PCH H/S**

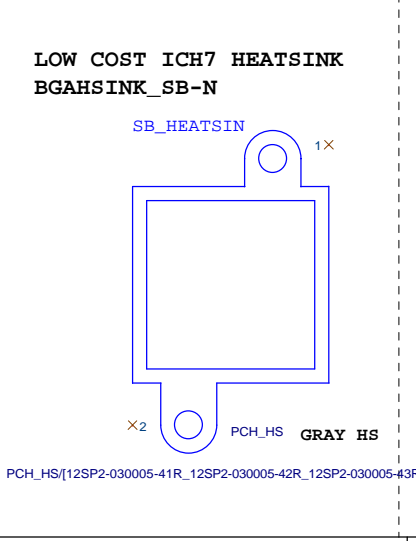

**PCH (E)**

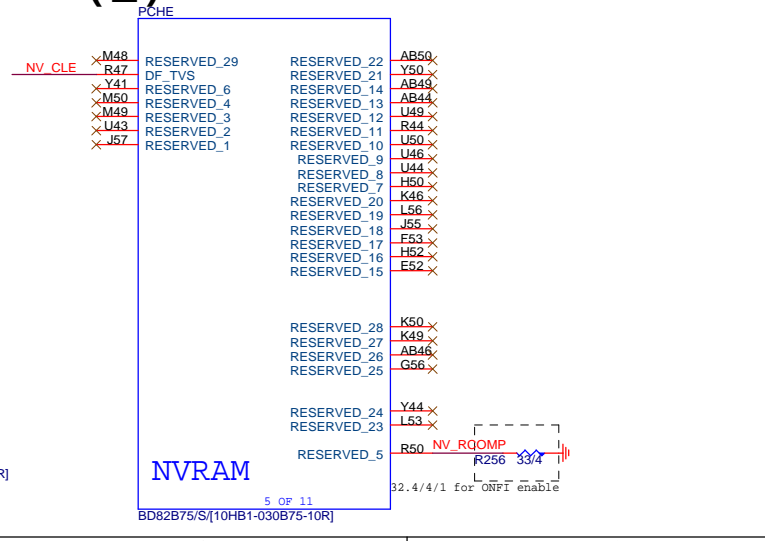

**-USBOC F/R PROTECT**

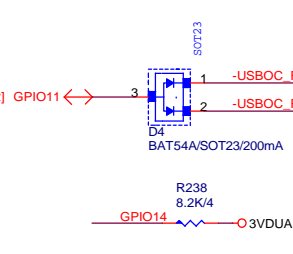

**PCH CLK PD**

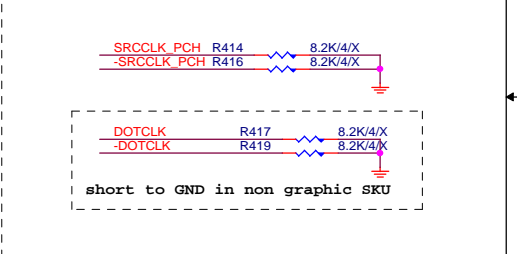

**NVRAM PU**

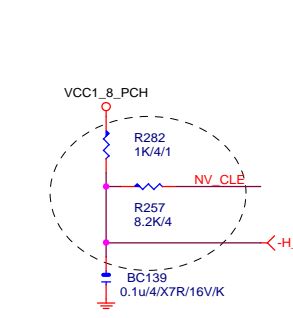

**USB TABLE**

USB OC#	Configure
OC0#	USB0_1 (F_USB30)
OC1#	USB2_3 (USB30_20)
OC2#	USB4_5 (F_USB1)
OC3#	USB6_7 (B75:N/A)
OC4#	USB8_9 (F_USB2)
OC5#	USB10_11 (USB_LAN)
OC6#	USB12_13 (KB_USB)
OC7#	N/A

**Gigabyte Technology**

File: PCH FDI,DMI,USB ,PCIE,NVRAM

Size: Custom

Document Number: **GA-B75M-D3H**

Date: Friday, June 08, 2012

Sheet: 9 of 33

Rev: 1.1

**PCH (F)**

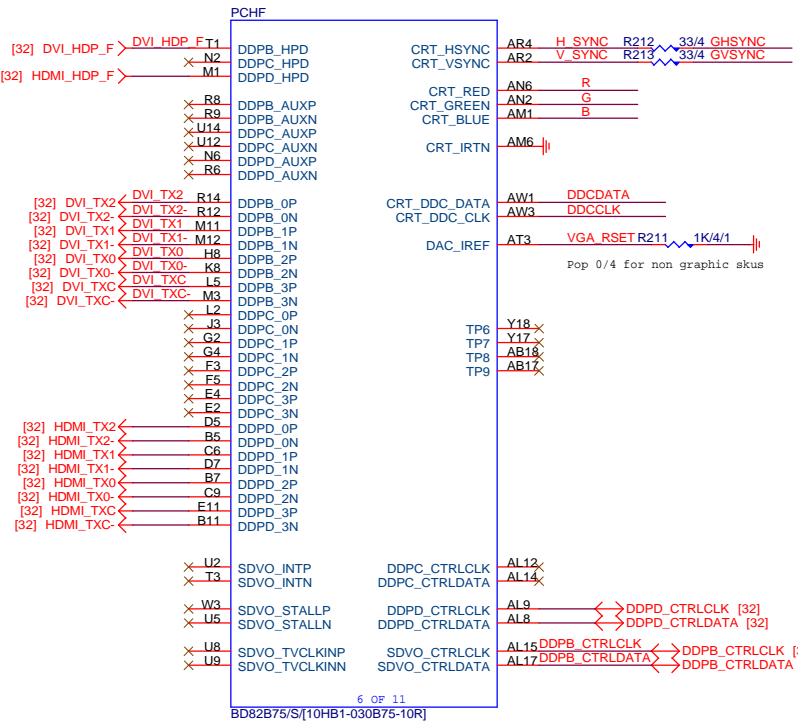

**PCH (F)**

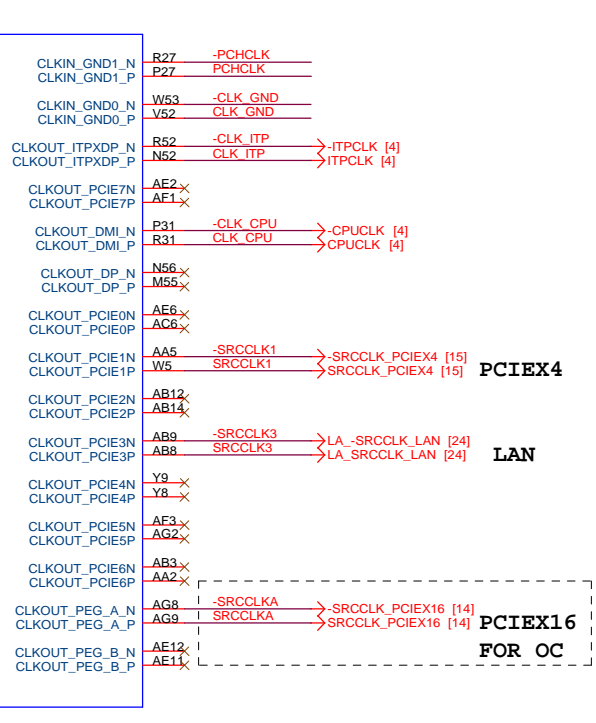
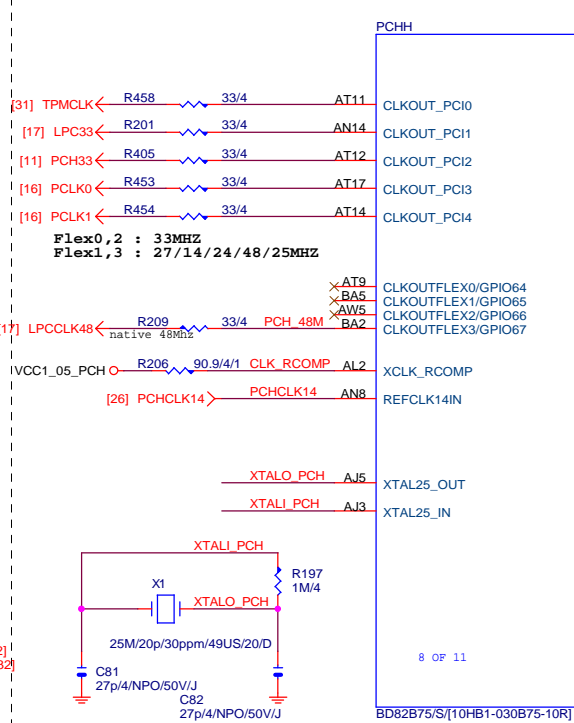

**PCH CLK PD**

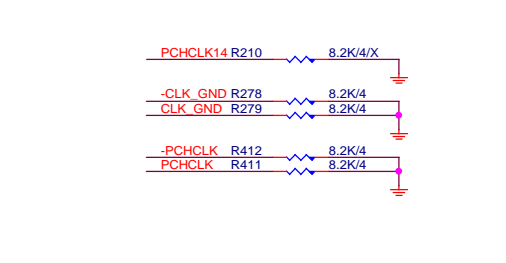

**VGA DDC**

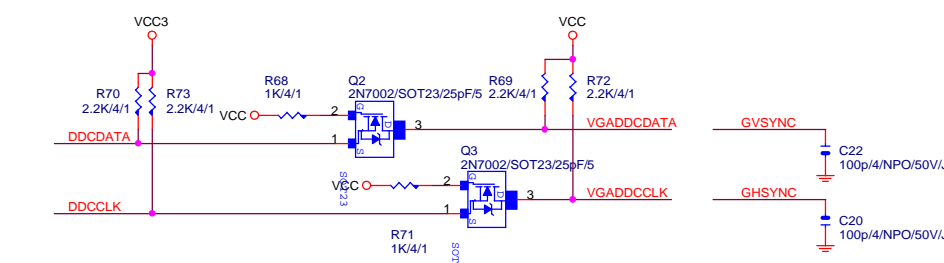

**VGA CONNECTOR**

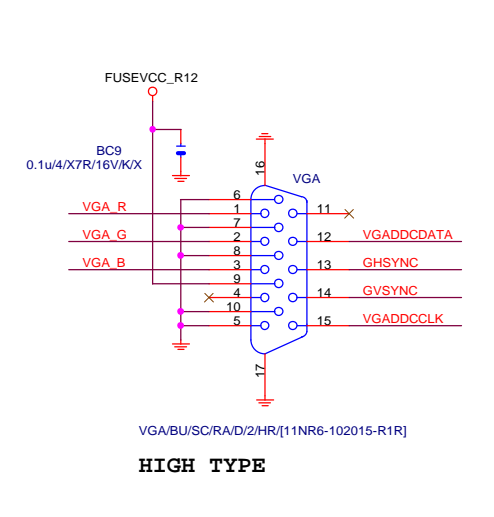

**VGA ESD**

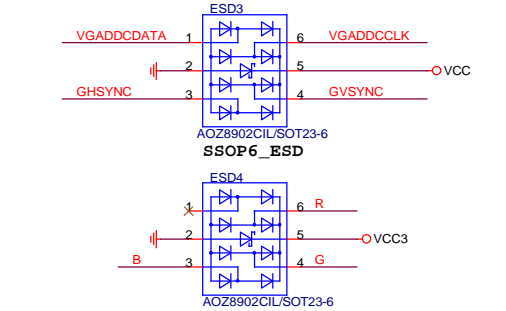

**VGA DDC**

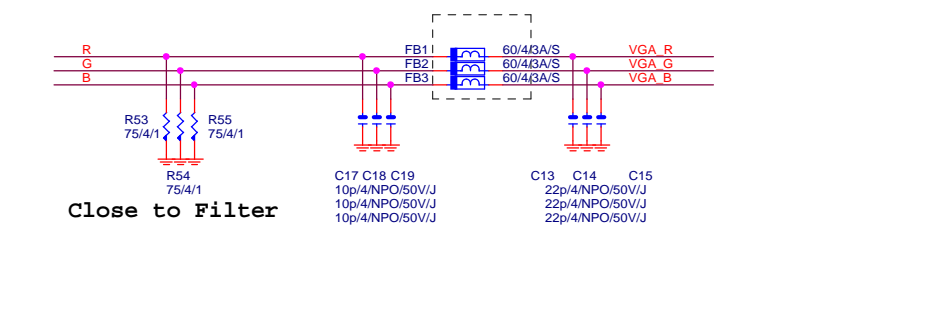

<b>Gigabyte Technology</b>	
Title <b>PCH DISPLAY , CLK BUFFER</b>	
Size Custom	Document Number <b>GA-B75M-D3H</b>
Date: Friday, June 08, 2012	Rev 1.1

**PCH (C)**

**B75 SATA3.0 ONLY PORT0**  
**B75 Not Support RAID**

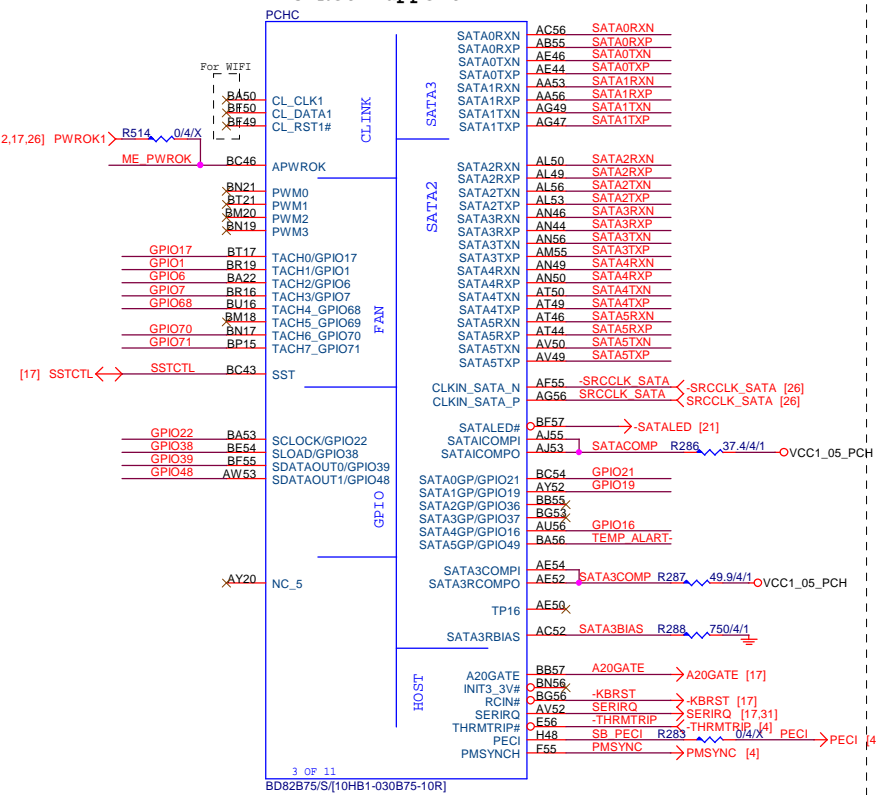

**PCH (A)**

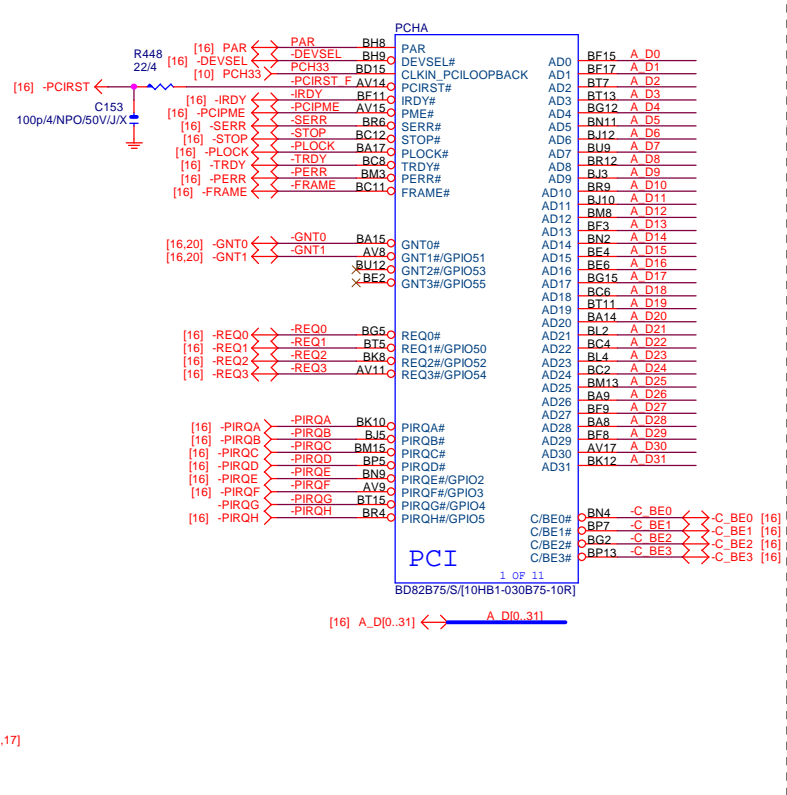

**PCH CLK PD**

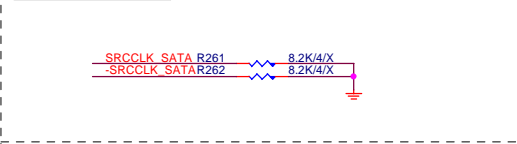

**PCH PU/PD**

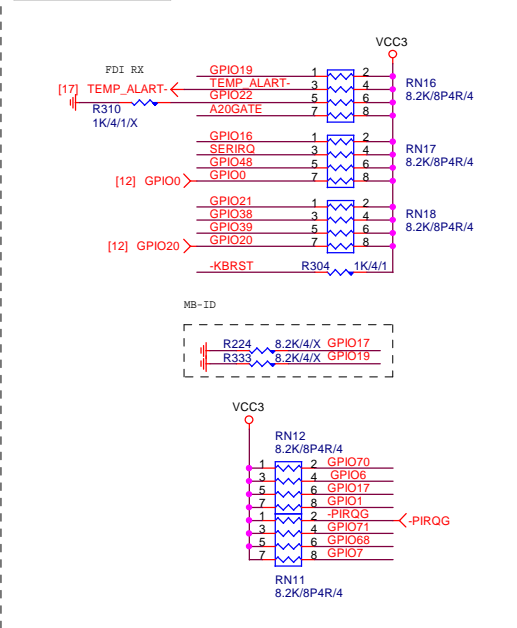

**SATA CONNECTOR H1X7-SATA2-HS-MASK**

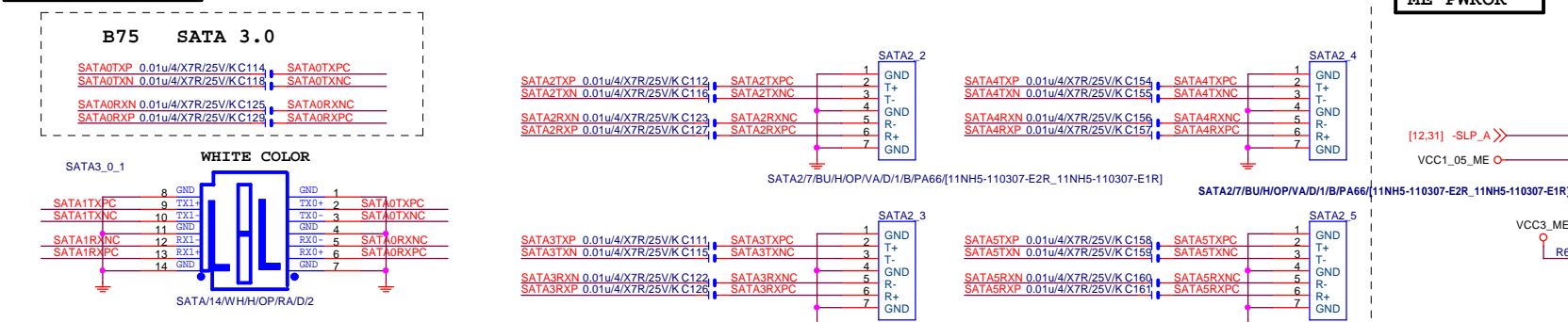

**ME PWROK**

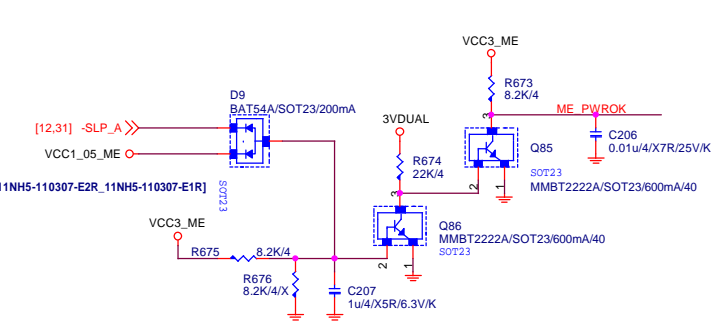

**Gigabyte Technology**

**PCH HOST , SATA, PCI**  
**GA-B75M-D3H**

Title	PCH HOST , SATA, PCI		
Size	Document Number	<b>GA-B75M-D3H</b>	
Custpm		Rev	1.1
Date:	Friday, June 08, 2012	Sheet	11 of 33

# PCH (D)

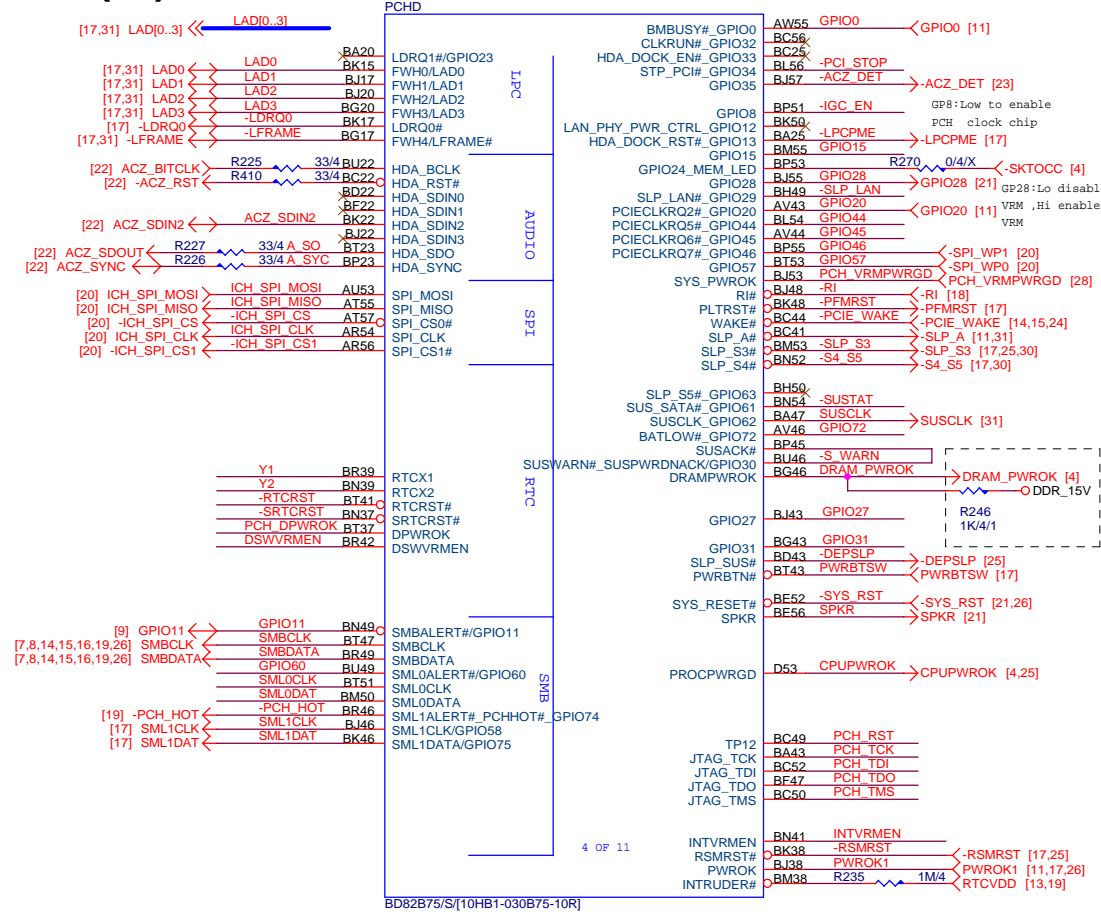

# PCH PU/PD

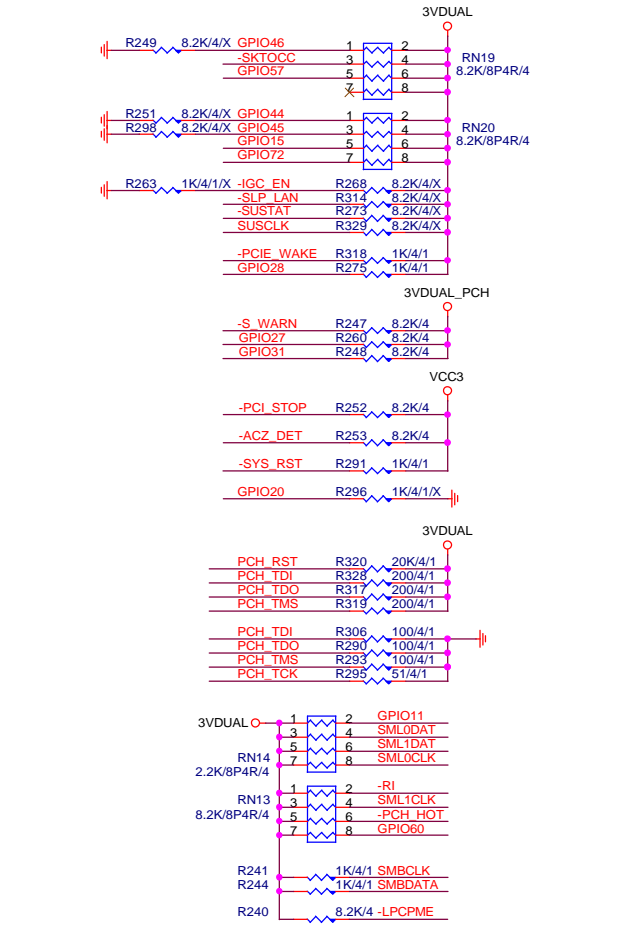

## PCH\_DPWROK

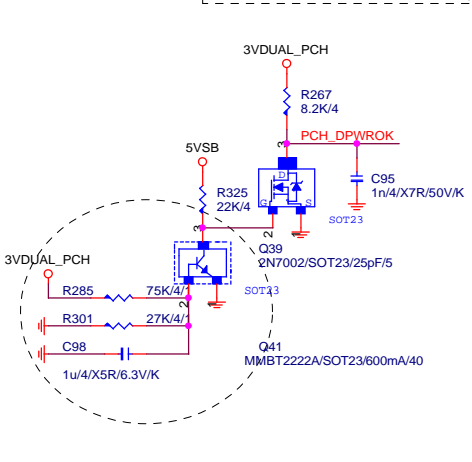

## 32.768KHZ

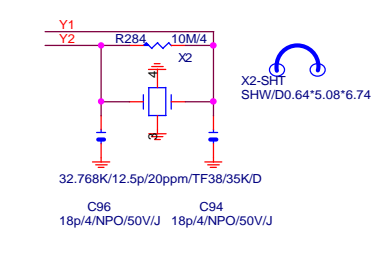

## ACZ\_SDOUT

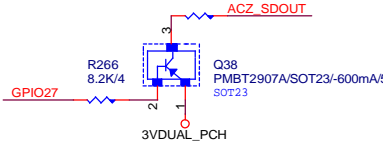

## CLR\_CMOS

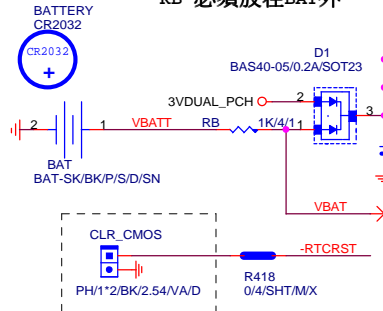

Gigabyte Technology		
Title PCH GPIO, CTRL, AUDIO		
Size	Document Number	Rev
Custpm	<b>GA-B75M-D3H</b>	<b>1.1</b>
Date:	Friday, June 08, 2012	Sheet 12 of 33

# PCH (I)

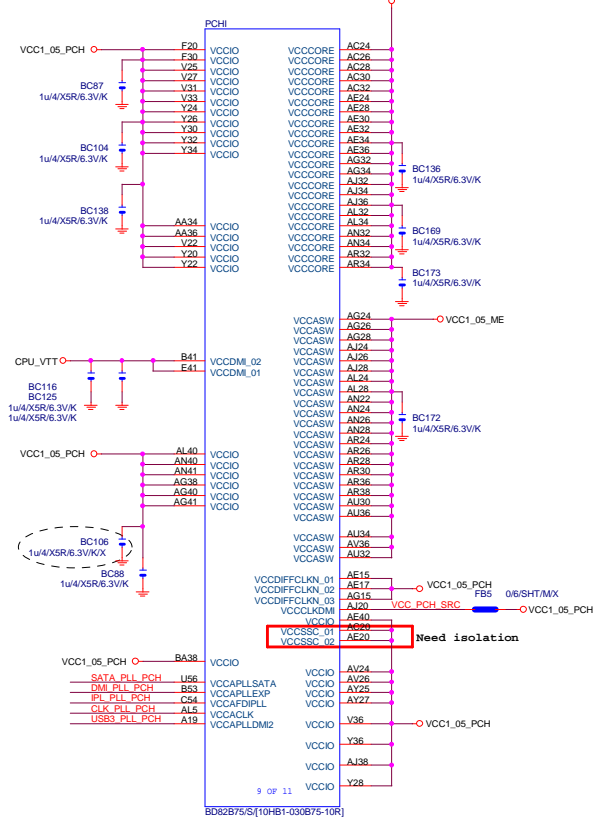

# PCH (J)

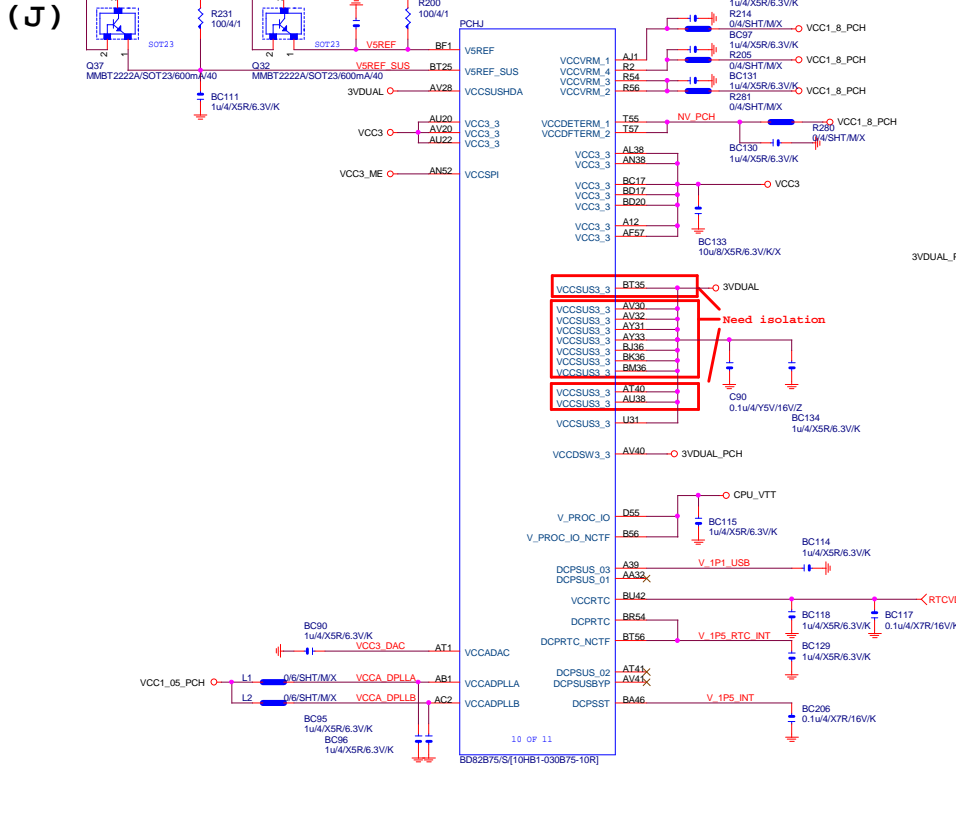

# SHT PWR

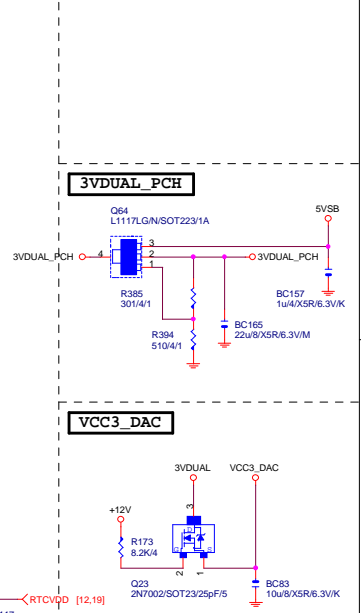

3VDUAL\_PCH

VCC3\_DAC



# CAP

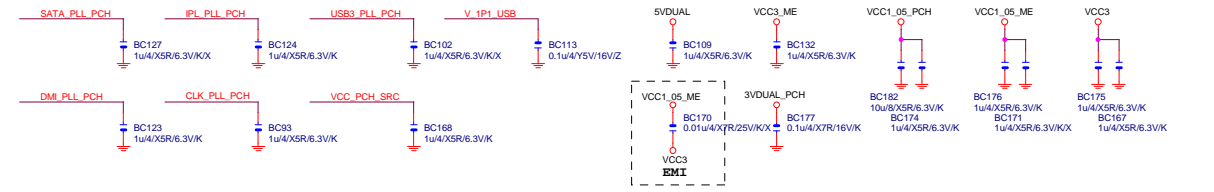

# PCH (I)

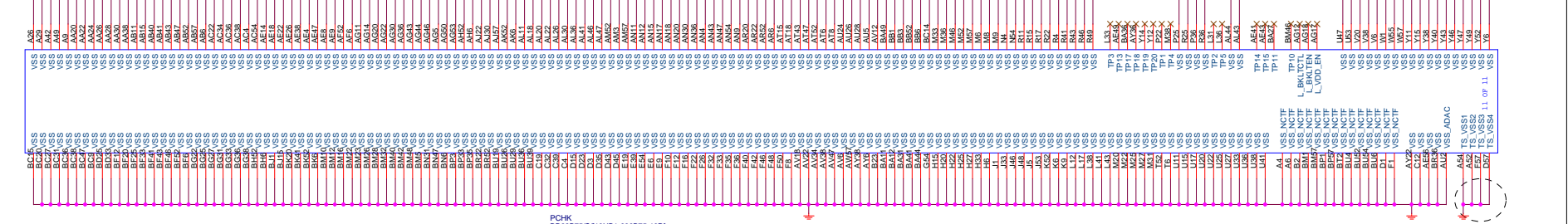

Gigabyte Technology

Title		
PCH PWR ,GND		
Document Number		Rev
GA-B75M-D3H		1.1
Date	Sheet	of
Friday, June 08, 2012	13	33



**PCIEX16 CAP**

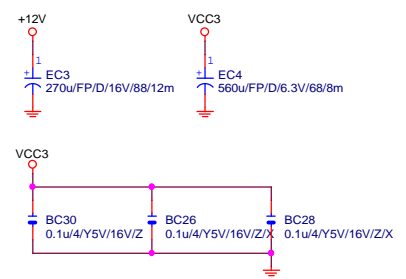

**PCIEX16 PROTECT SHT**

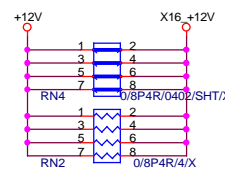

**PCIEX16 AC CAP**

EXP_A_TXP0	C32	0.22u/4X5R/6.3V/K	EXP_A_TXP0C
EXP_A_TXN0	C30	0.22u/4X5R/6.3V/K	EXP_A_TXN0C
EXP_A_TXP1	C35	0.22u/4X5R/6.3V/K	EXP_A_TXP1C
EXP_A_TXN1	C37	0.22u/4X5R/6.3V/K	EXP_A_TXN1C
EXP_A_TXP2	C39	0.22u/4X5R/6.3V/K	EXP_A_TXP2C
EXP_A_TXN2	C41	0.22u/4X5R/6.3V/K	EXP_A_TXN2C
EXP_A_TXP3	C43	0.22u/4X5R/6.3V/K	EXP_A_TXP3C
EXP_A_TXN3	C45	0.22u/4X5R/6.3V/K	EXP_A_TXN3C
EXP_A_TXP4	C46	0.22u/4X5R/6.3V/K	EXP_A_TXP4C
EXP_A_TXN4	C49	0.22u/4X5R/6.3V/K	EXP_A_TXN4C
EXP_A_TXP5	C50	0.22u/4X5R/6.3V/K	EXP_A_TXP5C
EXP_A_TXN5	C51	0.22u/4X5R/6.3V/K	EXP_A_TXN5C
EXP_A_TXP6	C52	0.22u/4X5R/6.3V/K	EXP_A_TXP6C
EXP_A_TXN6	C54	0.22u/4X5R/6.3V/K	EXP_A_TXN6C
EXP_A_TXP7	C57	0.22u/4X5R/6.3V/K	EXP_A_TXP7C
EXP_A_TXN7	C58	0.22u/4X5R/6.3V/K	EXP_A_TXN7C
EXP_A_TXP8	C60	0.22u/4X5R/6.3V/K	EXP_A_TXP8C
EXP_A_TXN8	C61	0.22u/4X5R/6.3V/K	EXP_A_TXN8C
EXP_A_TXP9	C62	0.22u/4X5R/6.3V/K	EXP_A_TXP9C
EXP_A_TXN9	C63	0.22u/4X5R/6.3V/K	EXP_A_TXN9C
EXP_A_TXP10	C64	0.22u/4X5R/6.3V/K	EXP_A_TXP10C
EXP_A_TXN10	C65	0.22u/4X5R/6.3V/K	EXP_A_TXN10C
EXP_A_TXP11	C66	0.22u/4X5R/6.3V/K	EXP_A_TXP11C
EXP_A_TXN11	C67	0.22u/4X5R/6.3V/K	EXP_A_TXN11C
EXP_A_TXP12	C68	0.22u/4X5R/6.3V/K	EXP_A_TXP12C
EXP_A_TXN12	C70	0.22u/4X5R/6.3V/K	EXP_A_TXN12C
EXP_A_TXP13	C72	0.22u/4X5R/6.3V/K	EXP_A_TXP13C
EXP_A_TXN13	C73	0.22u/4X5R/6.3V/K	EXP_A_TXN13C
EXP_A_TXP14	C74	0.22u/4X5R/6.3V/K	EXP_A_TXP14C
EXP_A_TXN14	C75	0.22u/4X5R/6.3V/K	EXP_A_TXN14C
EXP_A_TXP15	C77	0.22u/4X5R/6.3V/K	EXP_A_TXP15C
EXP_A_TXN15	C78	0.22u/4X5R/6.3V/K	EXP_A_TXN15C

EXP\_A\_RXP0[.15] >>> EXP\_A\_RXP[0..15] [4]  
 EXP\_A\_RXN0[.15] >>> EXP\_A\_RXN[0..15] [4]  
 EXP\_A\_TXP0[.15] >>> EXP\_A\_TXP[0..15] [4]  
 EXP\_A\_TXN0[.15] >>> EXP\_A\_TXN[0..15] [4]

**PCIEX16 SLOT**

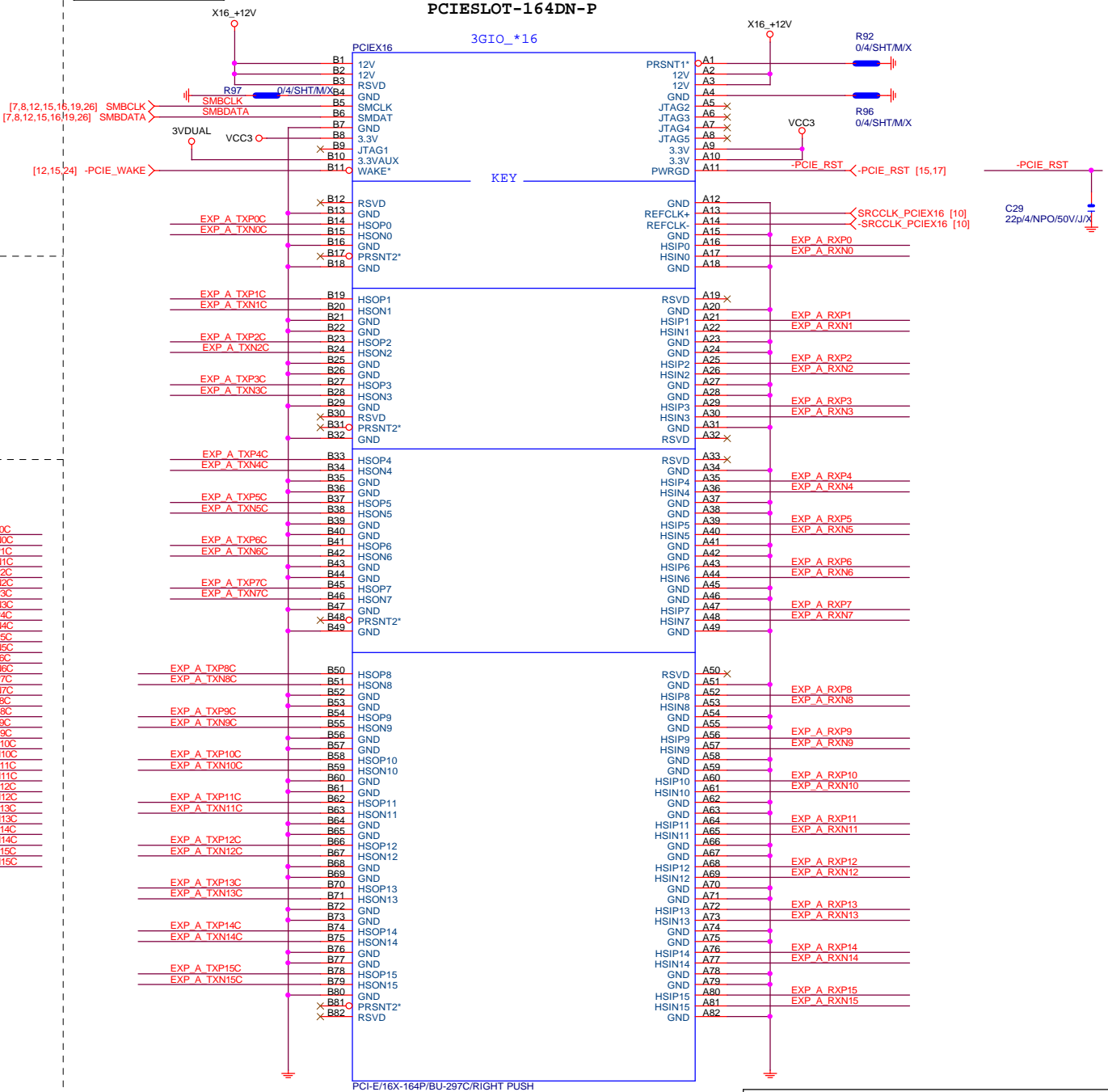

**PCIESLOT-164DN-P**

**Gigabyte Technology**

Title		
PCI EXPRESS * 16		
Size	Document Number	Rev
Custom	<b>GA-B75M-D3H</b>	<b>1.1</b>
Date:	Friday, June 08, 2012	Sheet 14 of 33

**PCIEX4 CAP**

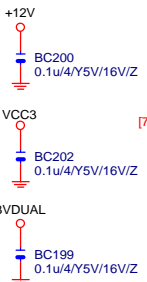

**PCIEX16 PROTECT SHT**

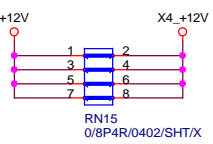

**PCIEX4 SLOT**

**PCIESLOT-64D-98D-P**

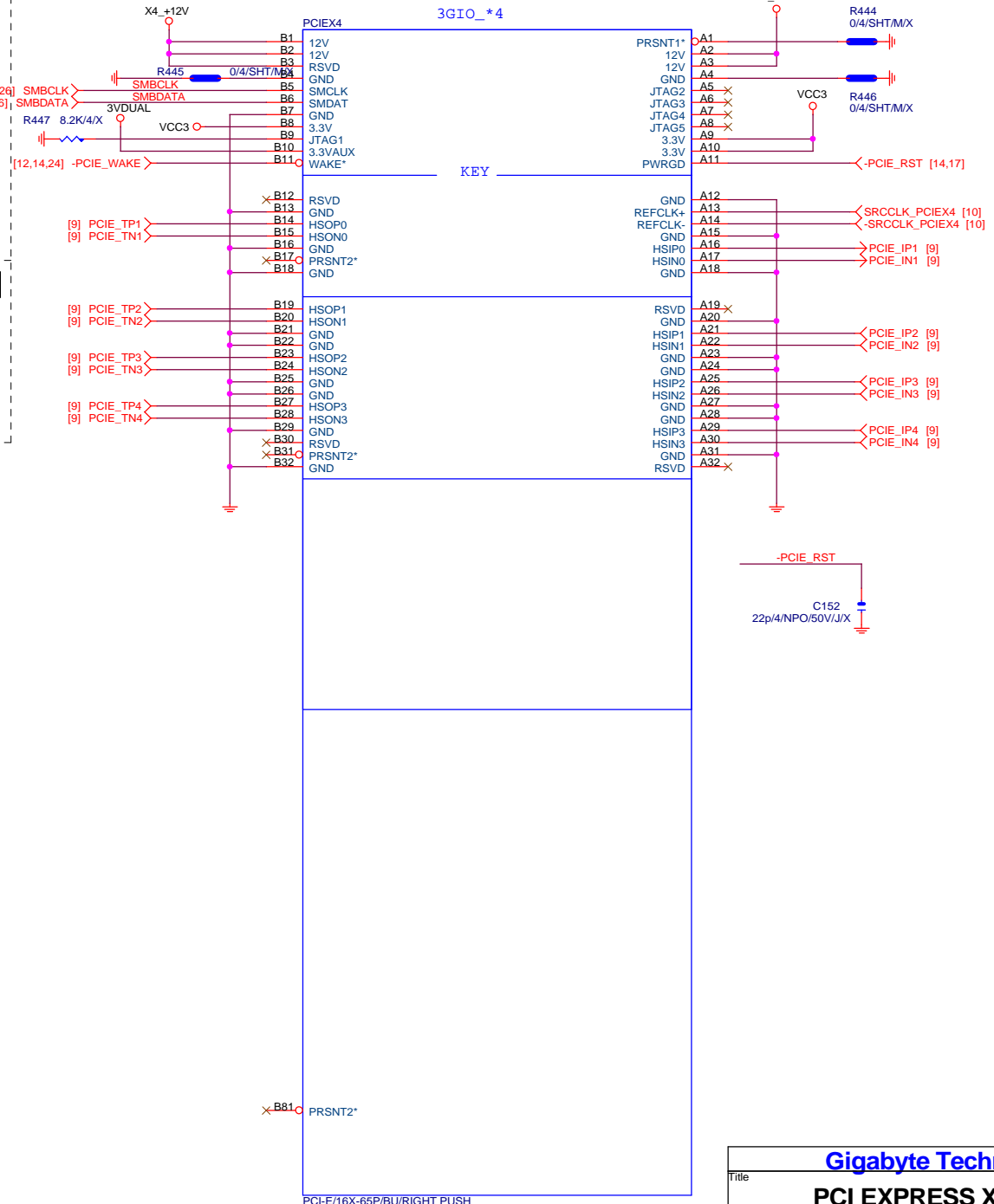

× B81 PRSNT2\*

PCI-E/16X-65P/BU/RIGHT PUSH

<b>Gigabyte Technology</b>		
<b>PCI EXPRESS X 4 PORT</b>		
Size Custom	Document Number <b>GA-B75M-D3H</b>	Rev <b>1.1</b>
Date: Friday, June 08, 2012	Sheet 15 of 33	



**PCI SLOT**

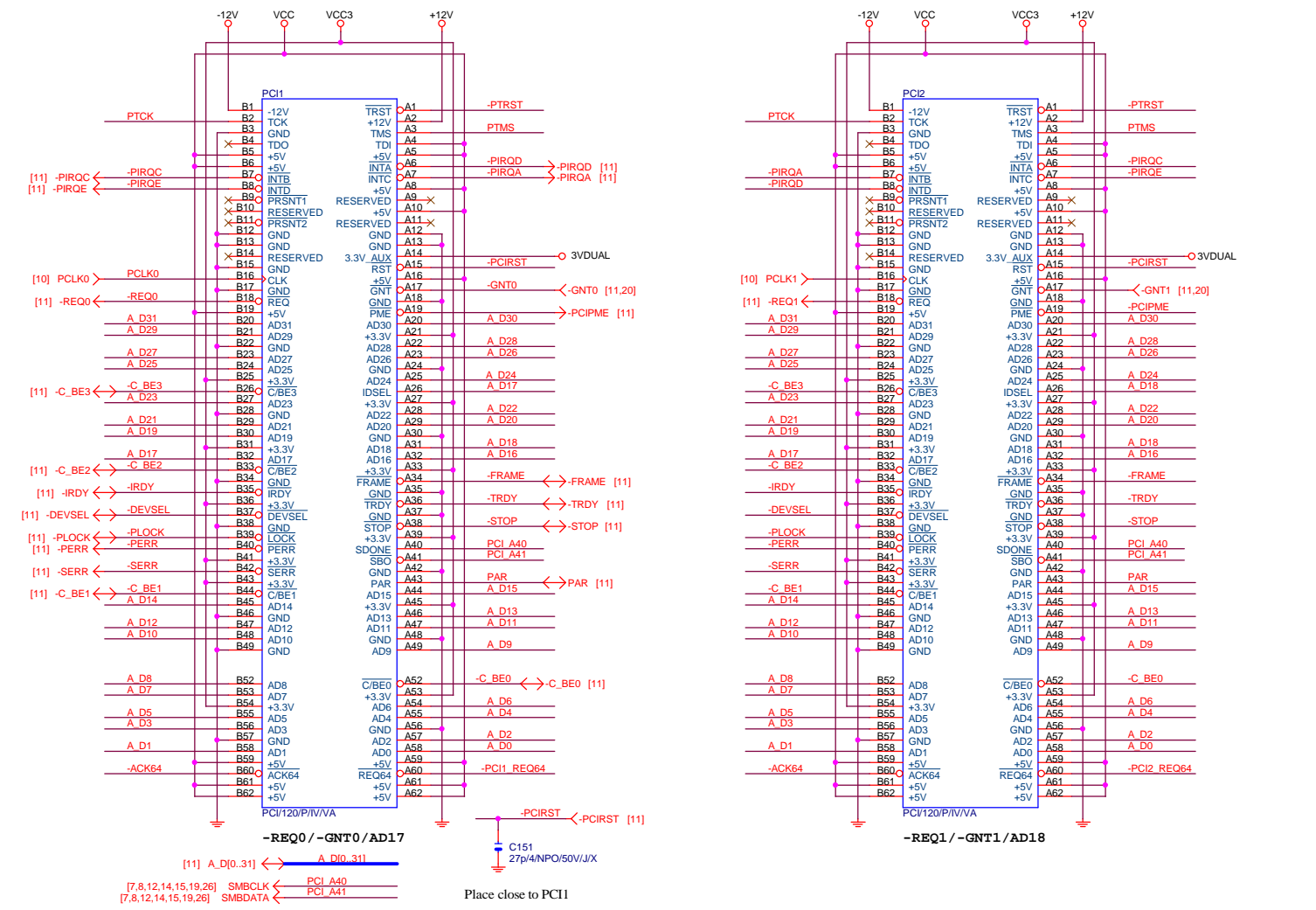

**PCI PU**

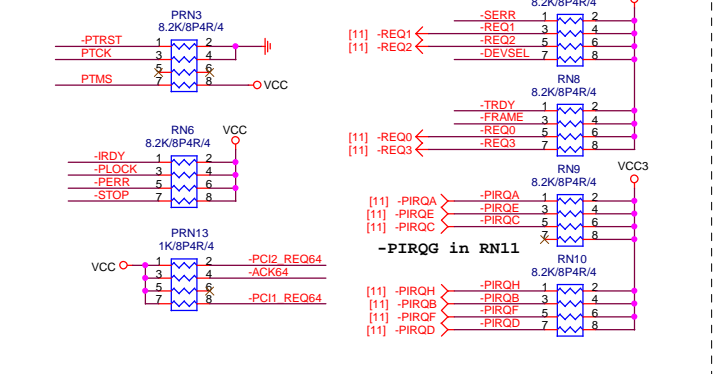

**PCI CAP**

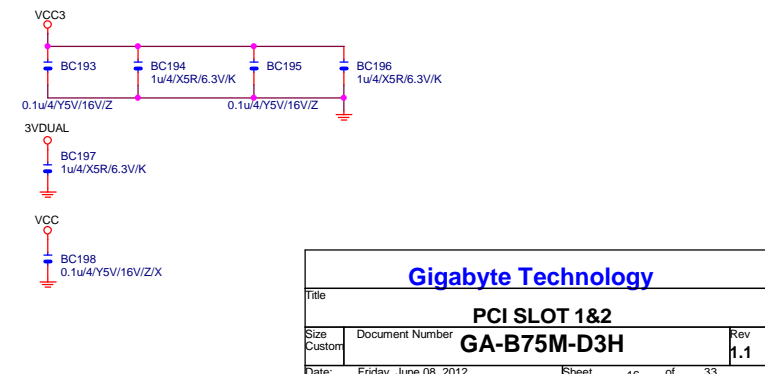

**Gigabyte Technology**

**PCI SLOT 1&2**

**GA-B75M-D3H**

Title	PCI SLOT 1&2	
Size	Document Number	Rev
Custom	GA-B75M-D3H	1.1
Date:	Friday, June 08, 2012	Sheet 16 of 33

**SIO IT8728F**

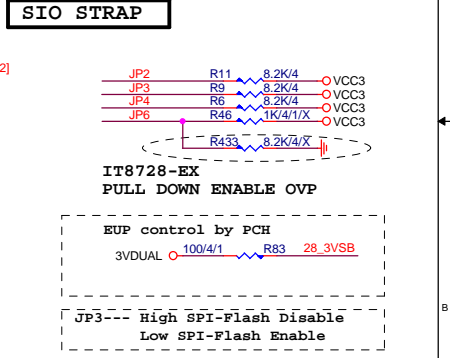
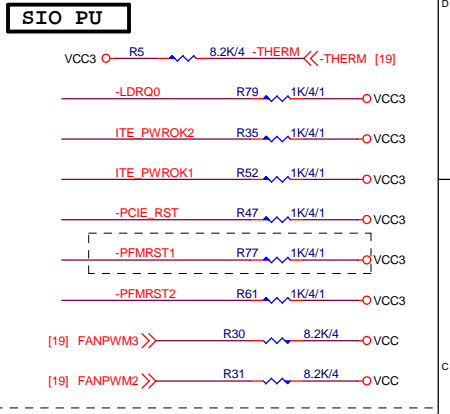
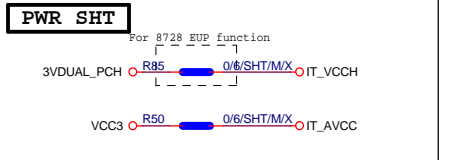
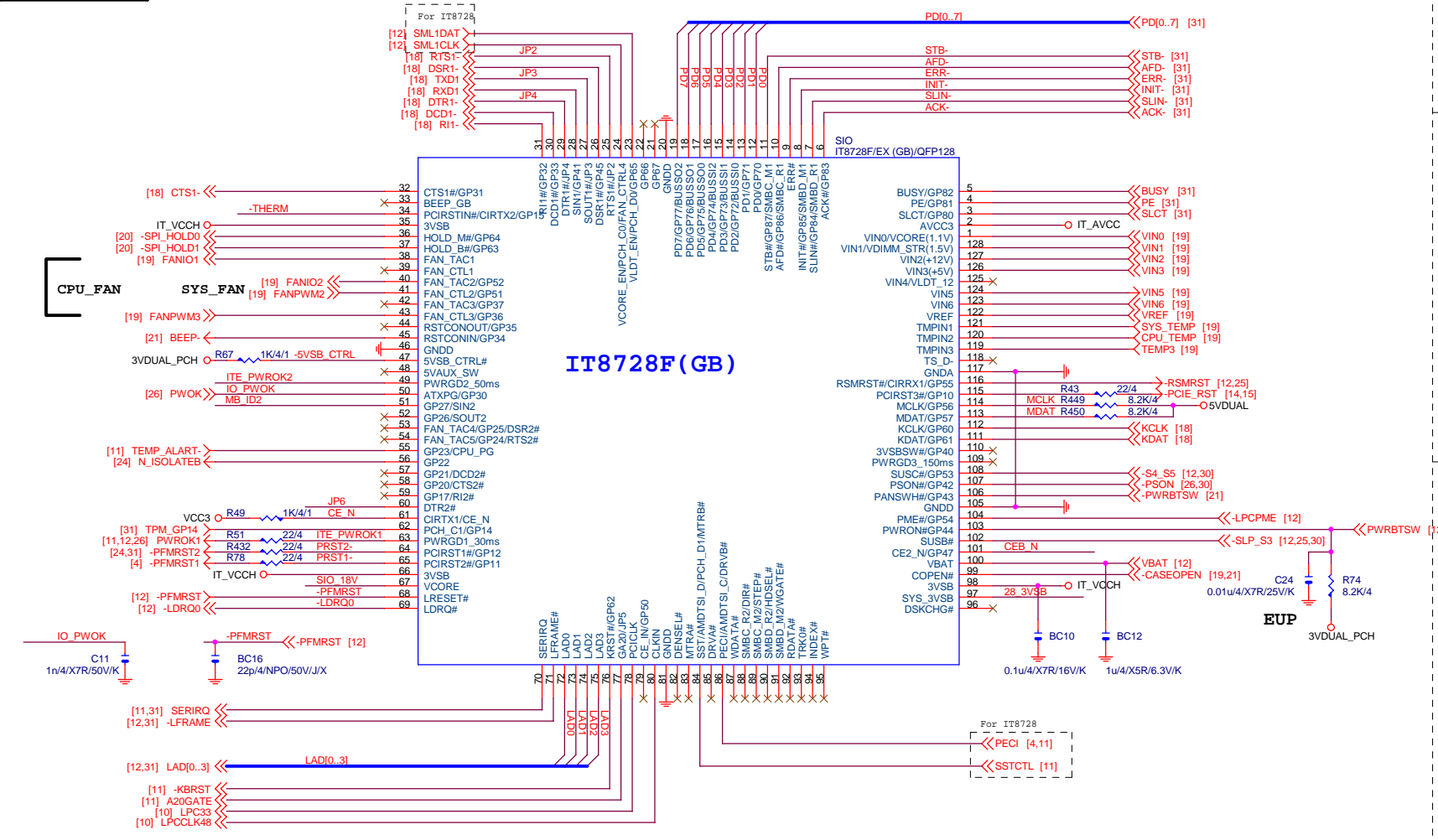

**IT8728F NOTE**

IT8728	
PIN121	VCORE_EN/PCH_C0
PIN120	VLDT_EN/PCH_D0
PIN19	ATXPG
PIN31	PCH_C1
PIN53	SST/AMDTSI_D/MTRB#/PCH_D1
PIN55	PECl/AMDTSI_C/DRVB#
PIN66	SYS_3VSB
PIN70	GP47
PIN95	VIN2 (VCC5)
PIN96	VIN1 (VCC12)
PIN97	VIN1/VDIMM_STR(1.5V)
PIN98	VINO/VCORE(1.1V)/NC

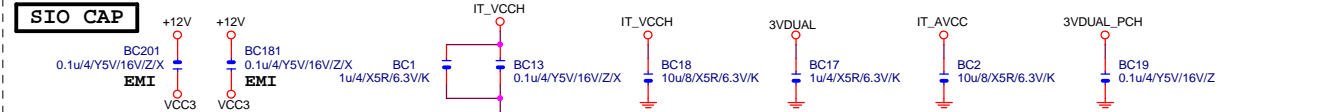
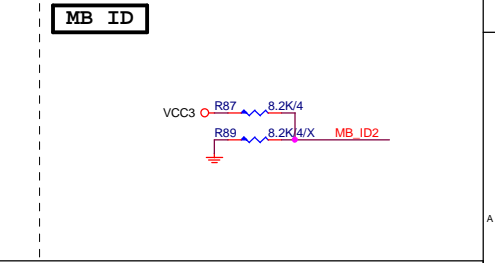
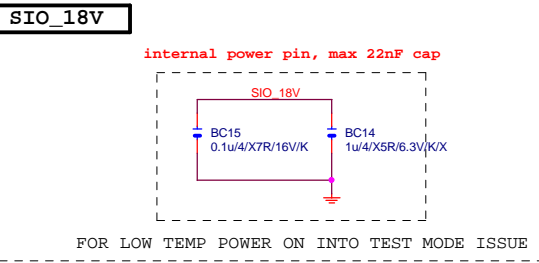
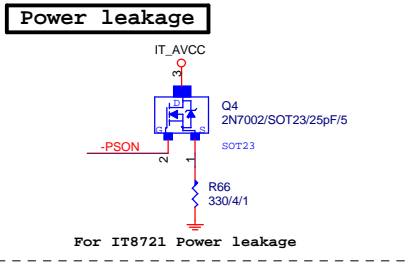
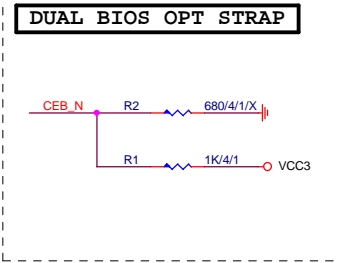

**Gigabyte Technology**

Title: **ITE 8728 LPC IO**

Size: Custom

Document Number: **GA-B75M-D3H**

Date: Friday, June 08, 2012

Rev: **1.1**

Sheet: 17 of 33

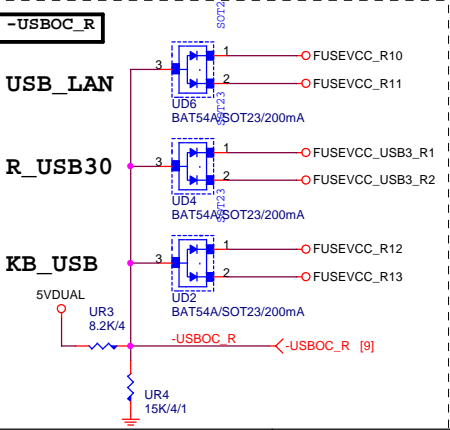
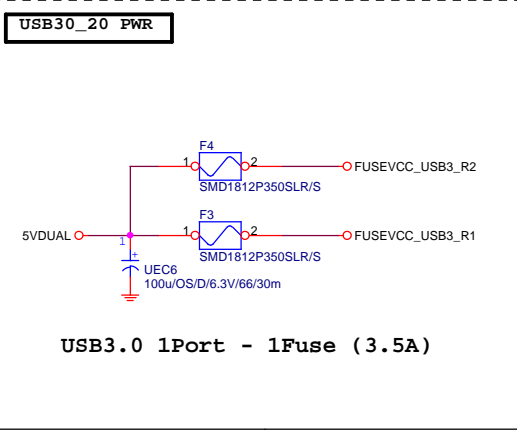
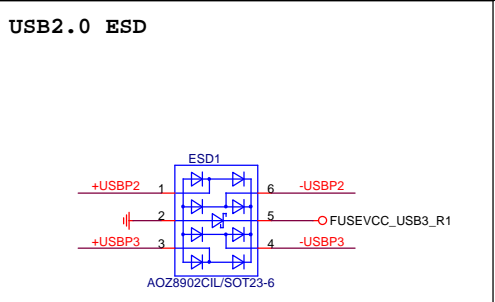
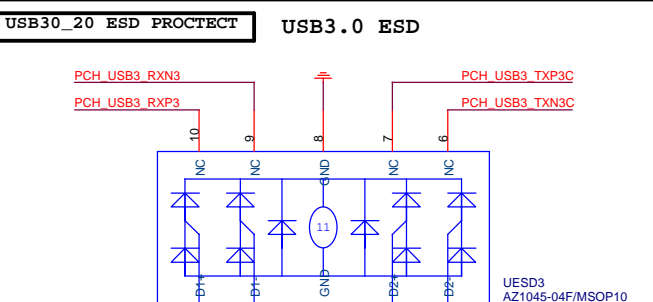
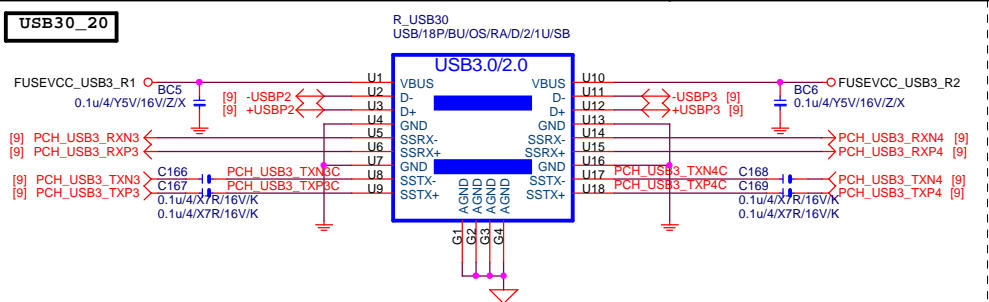
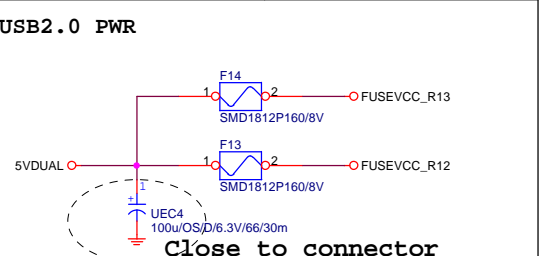
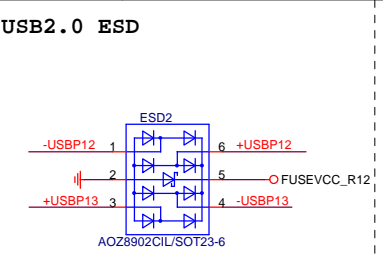
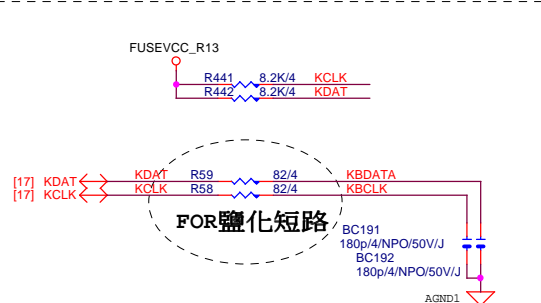
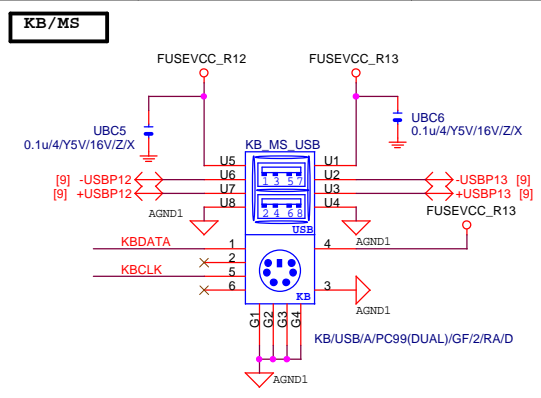
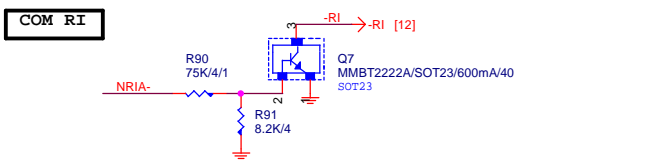
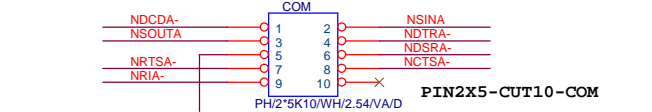
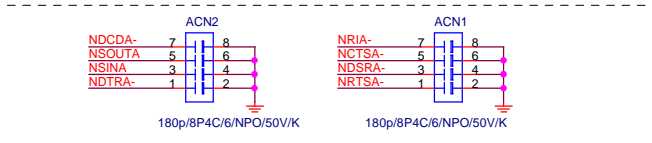
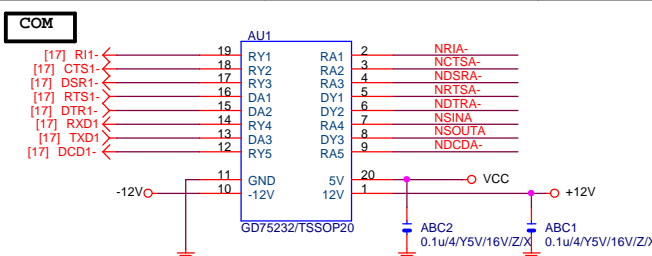

<b>Gigabyte Technology</b>			
Title: <b>COM,-RI,KB_USB,USB_ESATA,-PROCHOT</b>			
Size	Document Number	Rev	
Custom	<b>GA-B75M-D3H</b>	<b>1.1</b>	
Date:	Friday, June 08, 2012	Sheet	18 of 33

**TEMP H/W MONITOR**

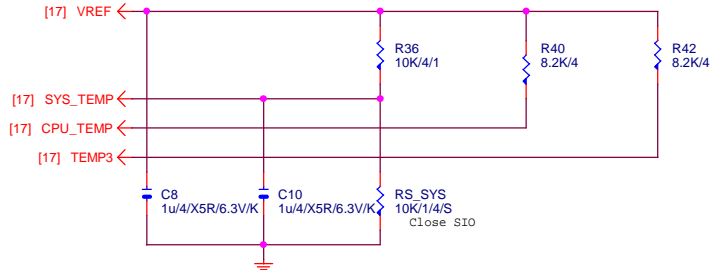

**CPU SMART FAN**

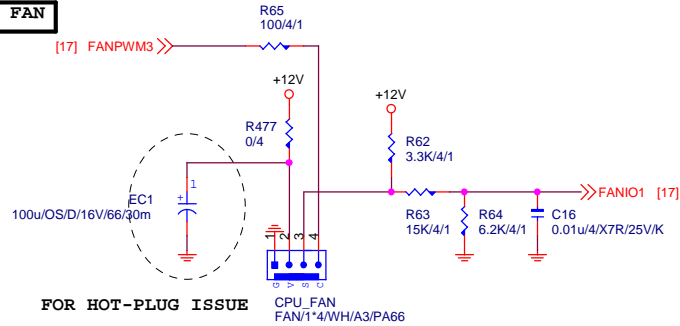

**CASE OPEN**

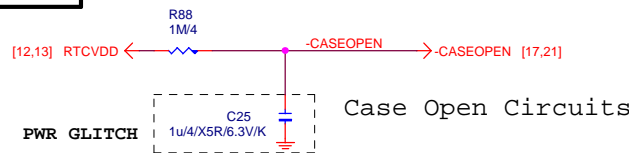

**SYS SMART FAN**

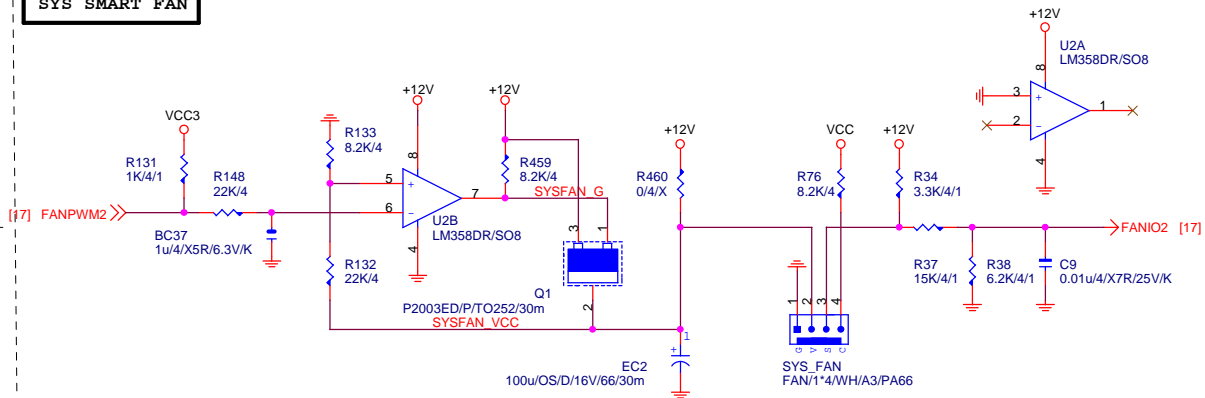

**VOLTAGE-- H/W MONITOR**

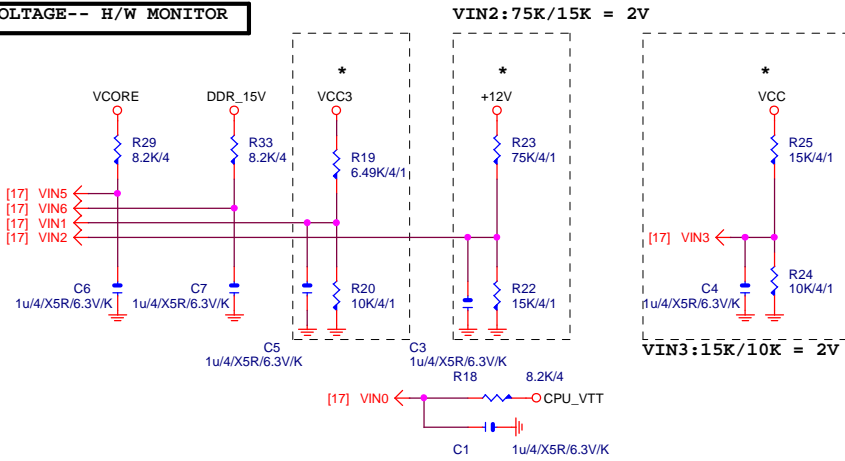

**-PROHOT**

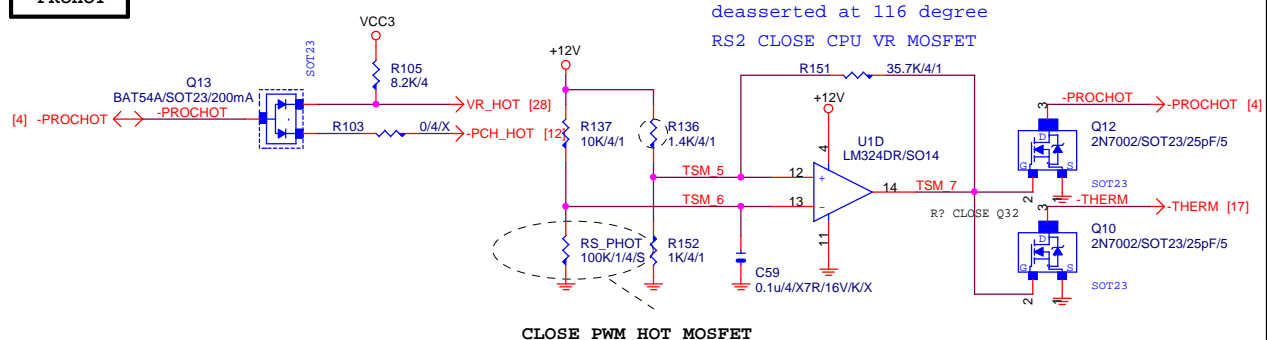

**OV NCT3933**

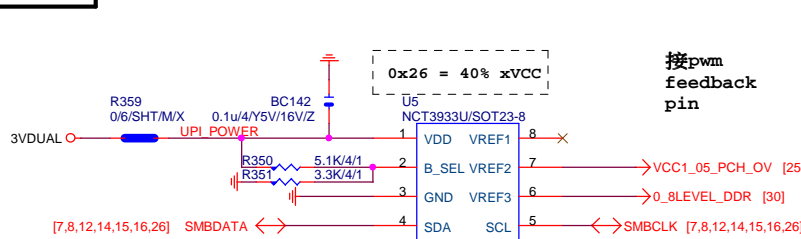

**Gigabyte Technology**

Title			HWM,FAN CTRL,OV		
Size	Document Number	Rev			
Custom	<b>GA-B75M-D3H</b>	1.1			
Date:	Friday, June 08, 2012	Sheet	19	of	33

# DUAL BIOS

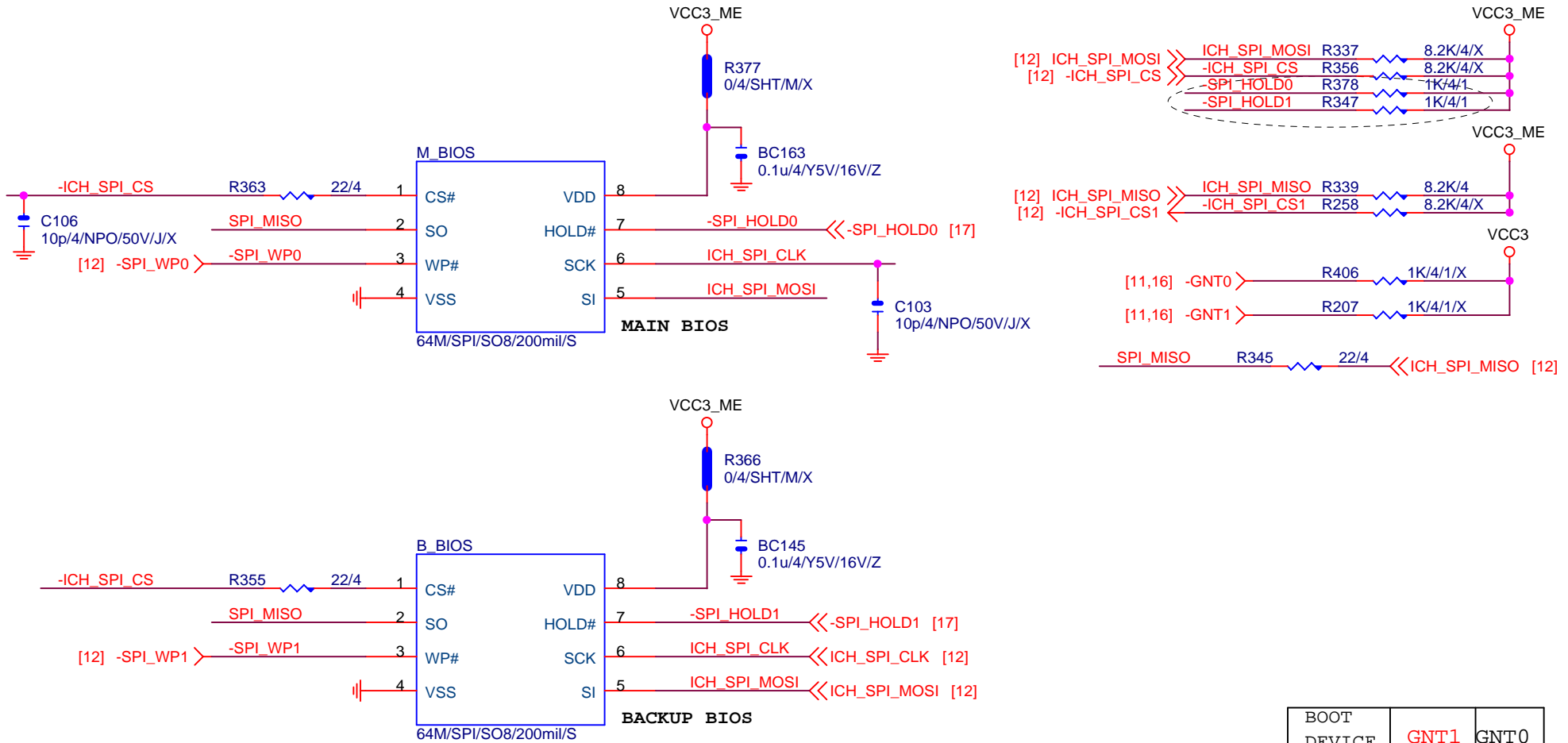

B65使用64M BIOS  
 使用H67暫用32M  
 H61使用32M BIOS

BOOT DEVICE	GNT1	GNT0
LPC	0	0
PCI	0	1
SPI	1	1

1 means floating  
 0 means PD 1K

**Gigabyte Technology**

Title		
<b>DUAL BIOS</b>		
Size A	Document Number	Rev
	<b>GA-B75M-D3H</b>	<b>1.1</b>
Date:	Friday, June 08, 2012	Sheet 20 of 33

**F\_USB30**

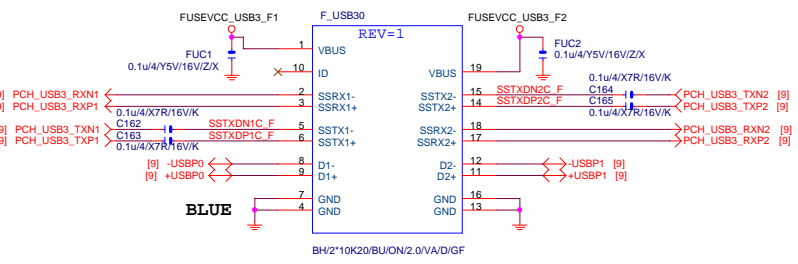

**F\_USB30 PWR**

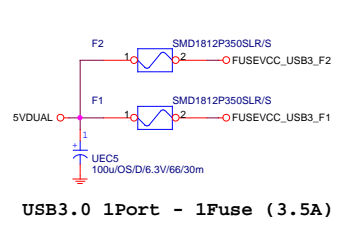

USB3.0 1Port - 1Fuse (3.5A)

**SATA LED**

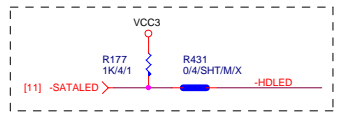

**F\_USB30 ESD PROTECT**

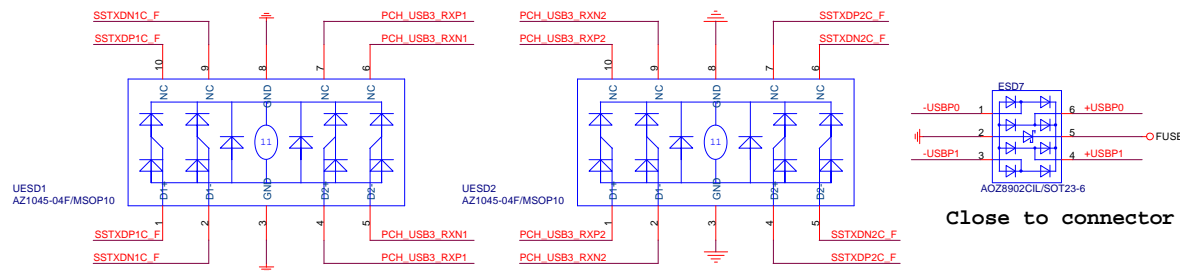

Close to connector

**SPKR**

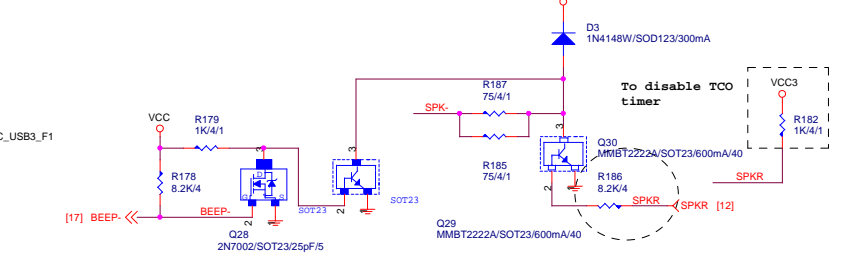

**FRONT USB1**

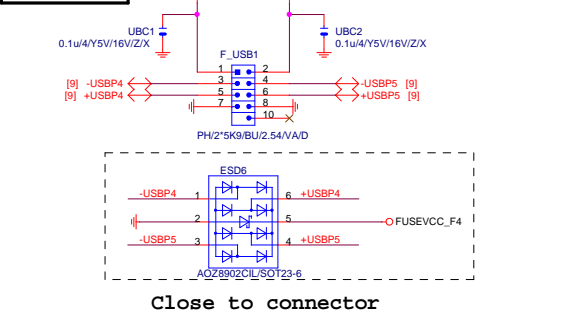

Close to connector

**FRONT USB2**

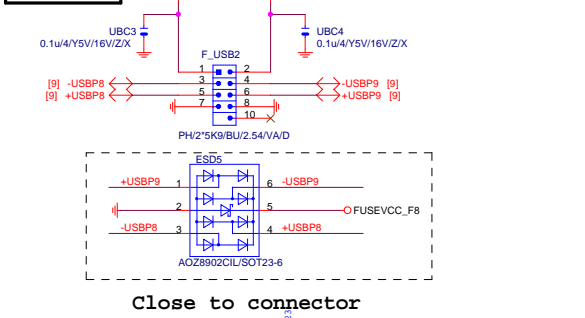

Close to connector

**INTEL FRONT PANEL**

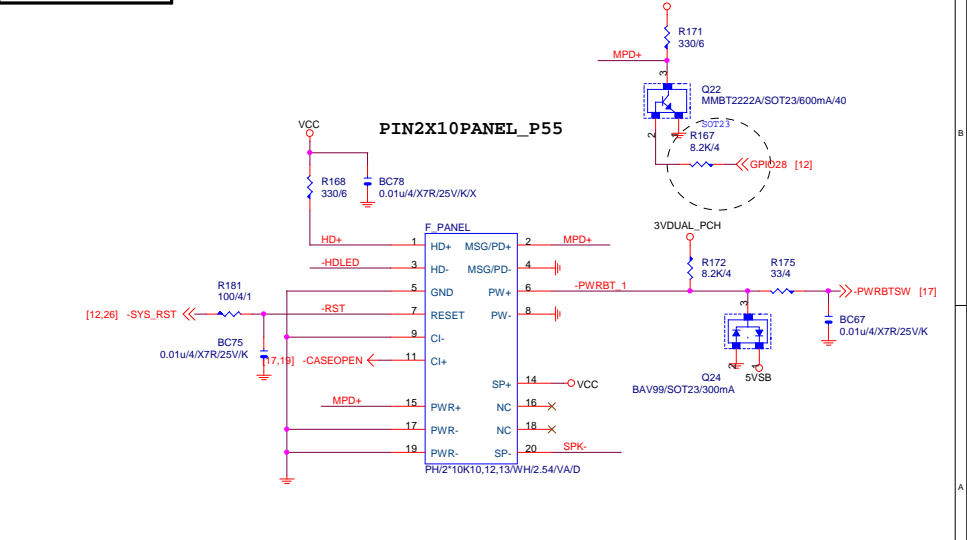

**FUSEVCC\_F**

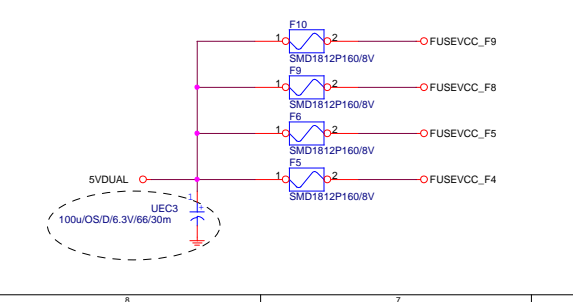

**-USBOC\_F**

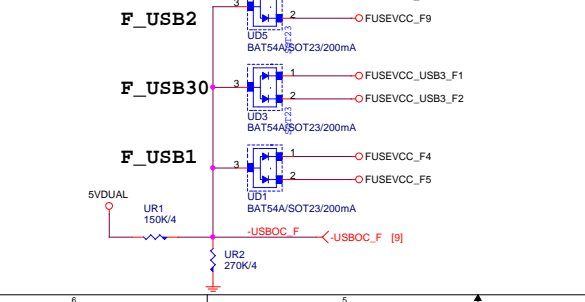

**Gigabyte Technology**

**FP,F\_USB,USB PWR,SPKR,SATA LED**

**GA-B75M-D3H**

Title	FP,F_USB,USB PWR,SPKR,SATA LED		Rev	1.1
Size	Custom	Document Number		
Date	Friday, June 08, 2012	Sheet	21	of 33

	ALC662	ALC887-VD2	ALC889	VT1708S	VT1708SCE
CR65	X	X	O	O	X
CR64	X	X	X	X	0.1u/4
CBC35	O	O	X	X	O
CR44/CBC6	47ohm+1nF	47ohm+1nF	47ohm+1nF	22ohm+100P	22ohm+100P
CR31	X	O	O	O	O
CR30	O	X	X	X	X
CBC1/CBC2	22uF/X5R	22uF/X5R	22uF/X5R	22uF/X5R	22uF/X5R
CR20	5.11K/4/1	5.11K/4/1	5.11K/4/1	5.1K/4/1	5.1K/4/1
CR34	20K/4/1	20K/4/1	20K/4/1	5.1K/4/1	20K/4/1
CBC39/CBC40	N/A	N/A	N/A	100P/4	100P/4
CR6/CR7/CR54/CR58	22K/4	22K/4	22K/4	10K/4	10K/4
CR5/CR8/CR11/CR4/ CR17/CR22/CR45/CR33/ CR47/CR40/CR26/CR37/ CR13/CR11/CR57/CR53	62 ohm	62 ohm	62 ohm	75 ohm	75 ohm
CR51/CD1/CBC7	O	O	X	X	O
CD2/CD3/CQ3/CQ5	X	X	O	O	X
CR1/CR14/CR17/CR22	62 ohm	62 ohm	62 ohm	75 ohm	1K ohm

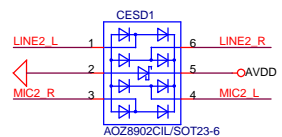
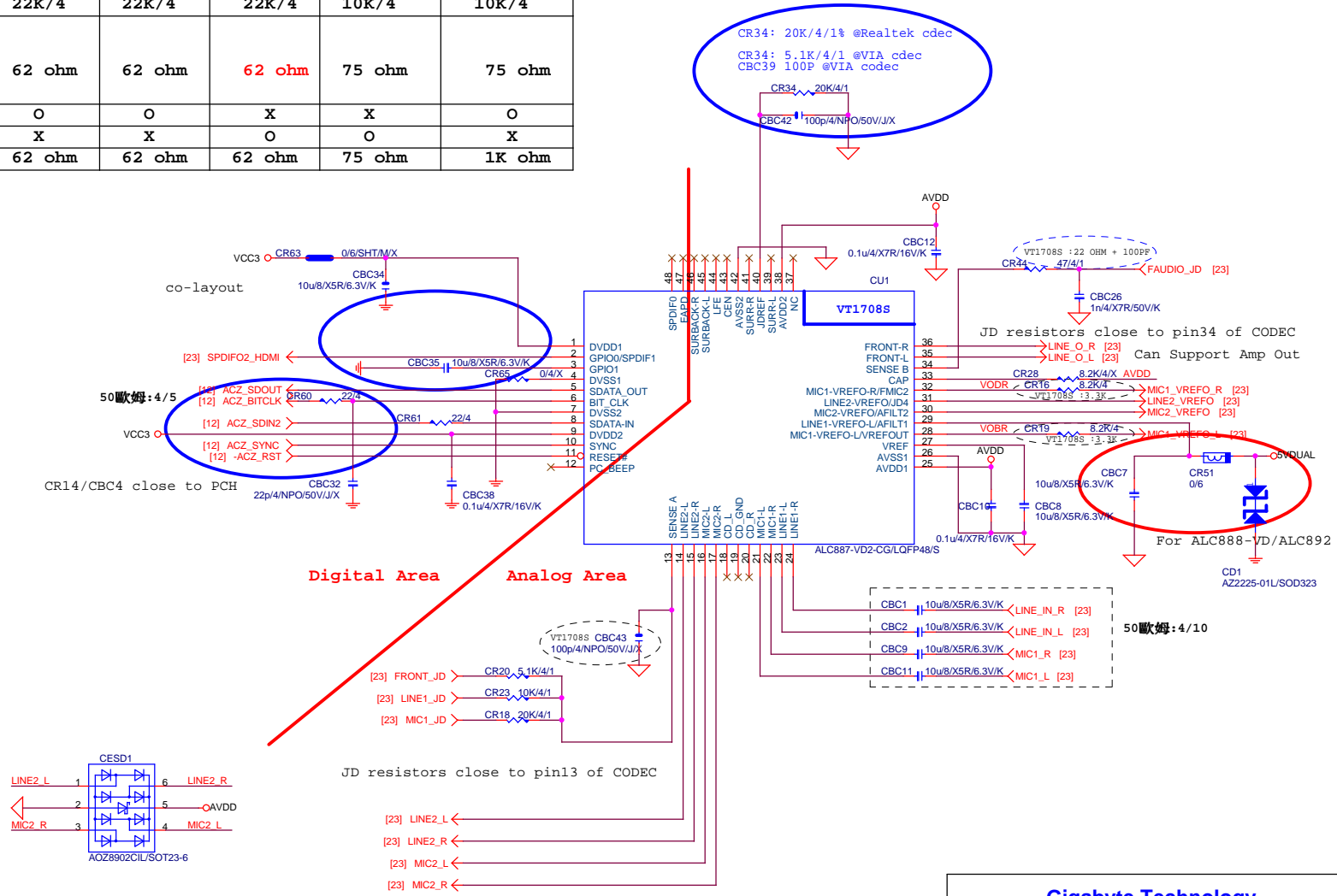



**CODEC POWER/EMI PAD**

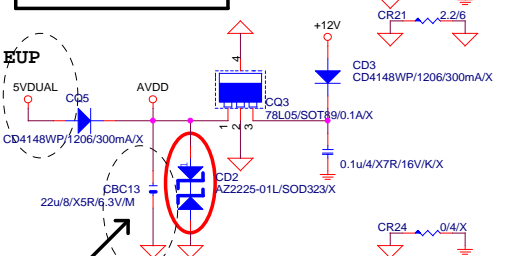

上ALC892時,此顆電容要保留  
ADD CD2 For ESD PROTECT DIODE

**LINE-OUT**

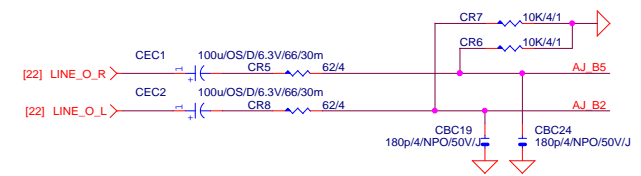

**LINE-IN**

Verify MIC function in LINE-in

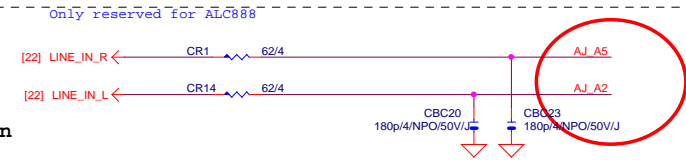

**MIC-IN**

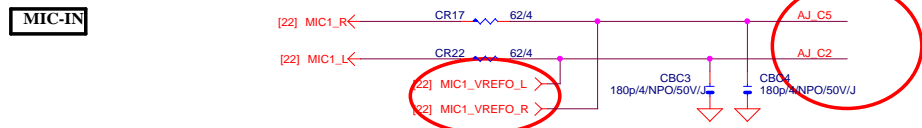

**SPDIF\_OUT**

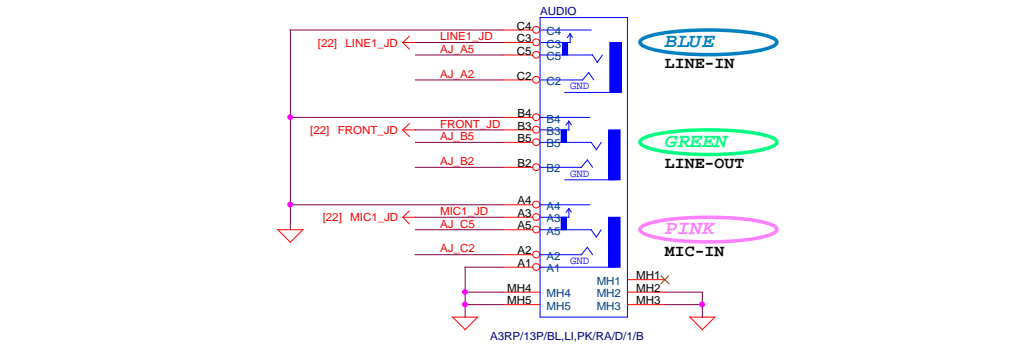
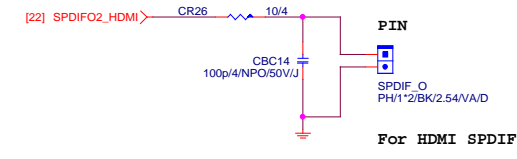

**AZALIA FRONT PANEL**

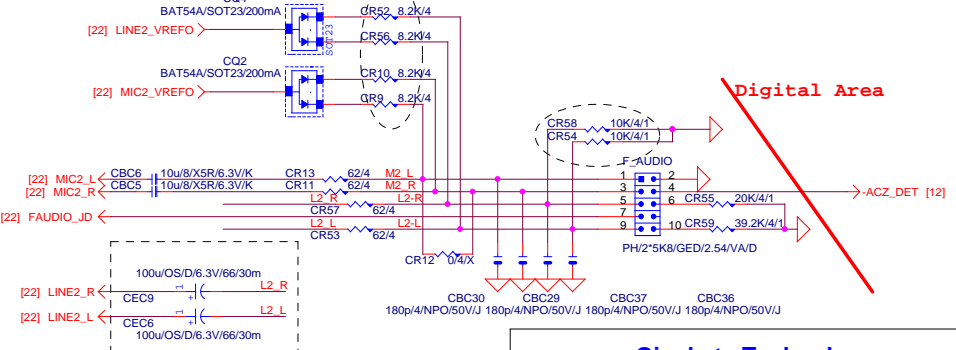

<b>Gigabyte Technology</b>			
<b>AUDIO JACK</b>			
Title		<b>GA-B75M-D3H</b>	
Size	Document Number	<b>GA-B75M-D3H</b>	
Custom			Rev <b>1.1</b>
Date:	Friday, June 08, 2012	Sheet	23 of 33

**LAN:RTL8111E/VB/VL**

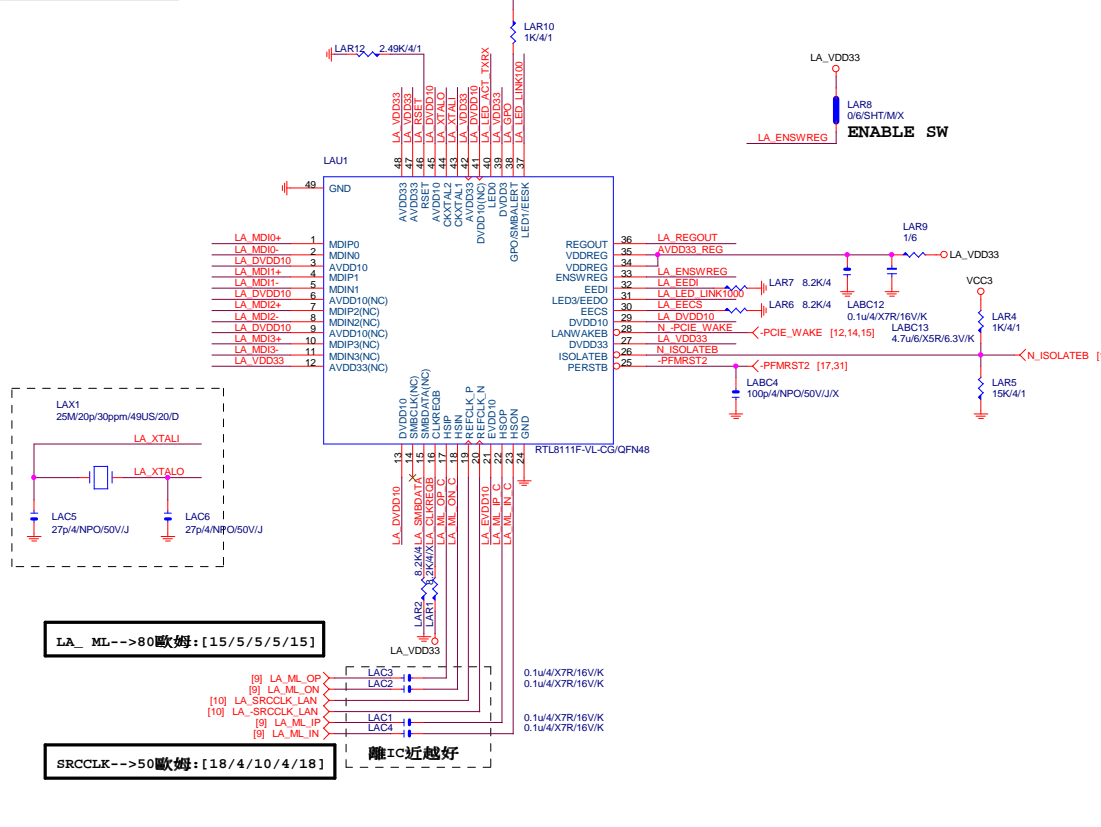

LA\_ML-->80歐姆:[15/5/5/15]

SRCCLK-->50歐姆:[18/4/10/4/18]

**USB\_LAN CONNECTOR**

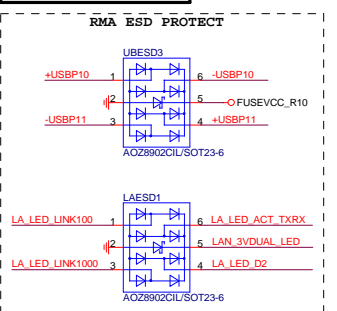

**注意:LAN LED PROTECT:(CO-LAYOUT)**  
 1.ESD(6PIN):AOZ8902CIL/SOT23-6(DEFAULT)  
 2.SURGE(5PIN):AZ2025-04S/SOT23-5L

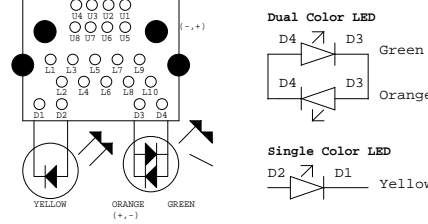

LA\_MDI-->100歐姆:[20/4/8/4/20]

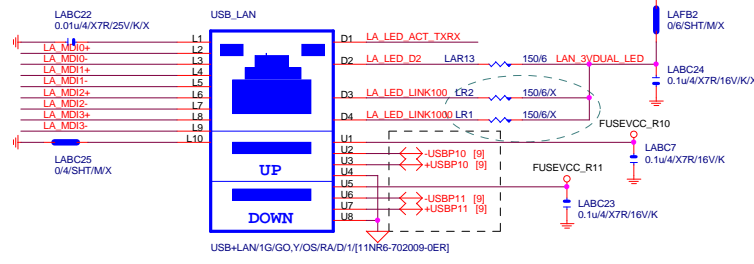

**注意:USB PORT(目前:暫代6,7PORT)**  
 USB-->90歐姆:[15/4.5/7.5/4.5/15]

料號	規格	廠商
11NR6-702009-0ER	1G LAN(12core)	UDE
11NR6-702009-91R	1G LAN(8 core)	FOXCONN
11NR6-702009-92R	1G LAN(8 core)	UDE
11NR6-702009-11R	1G LAN(12core/RED)	UDE
11NR6-702009-12R	1G LAN(8 core/RED)	FOXCONN

**USB\_LAN BOM區分:**  
 1.(紅色/12CORE/三倍):USB+LAN/1G/GO,Y/OS/RA/D/1/RED  
 2.(黑色/12CORE):USB+LAN/1G/GO,Y/OS/RA/D/1  
 3.(黑色/8CORE):USB+LAN/1G/GO,Y/OS/RA/D/8C

**LAN POWER**

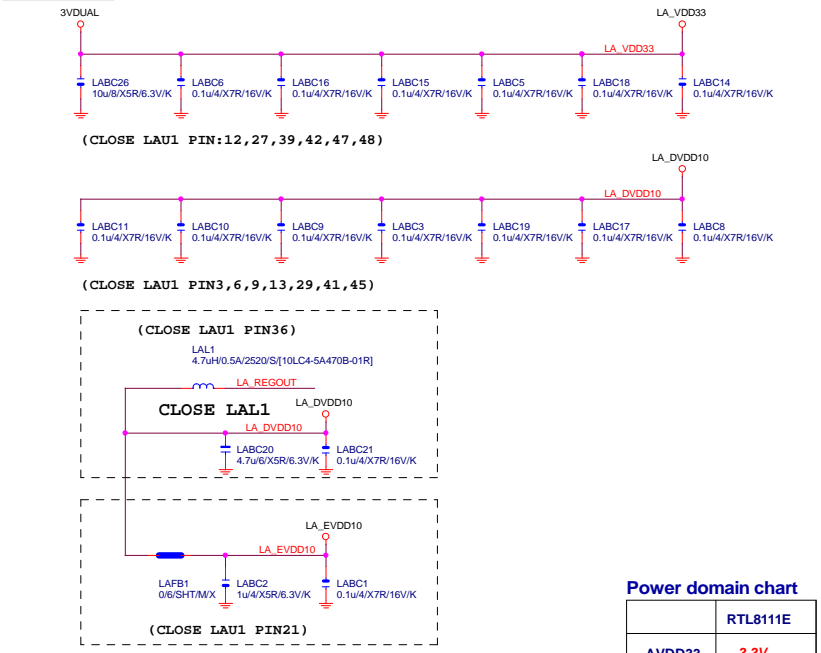

**Power domain chart**

	RTL8111E
AVDD33	3.3V
DVDD33	3.3V
VDDREG	3.3V
DVDD10	1.05V

**USB X3 POWER**

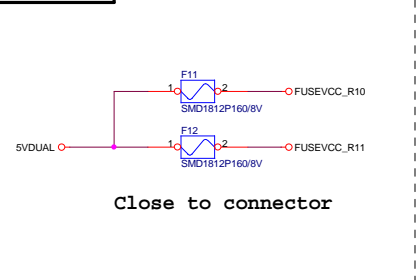

Close to connector

**EMI SHORT PAD**

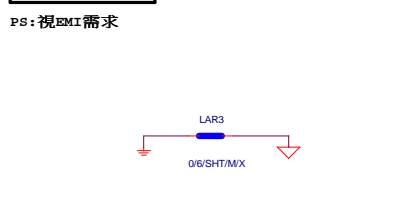

PS:視EMI需求

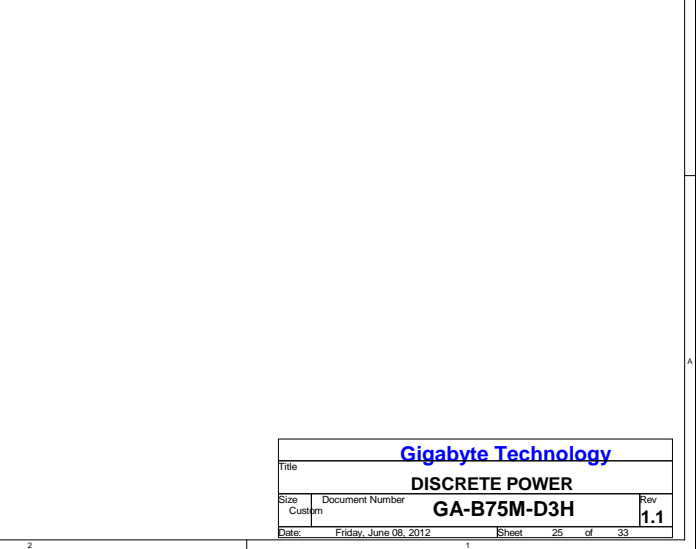
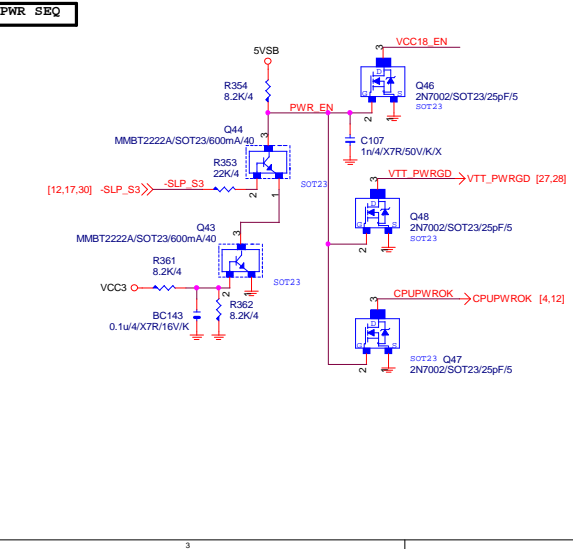
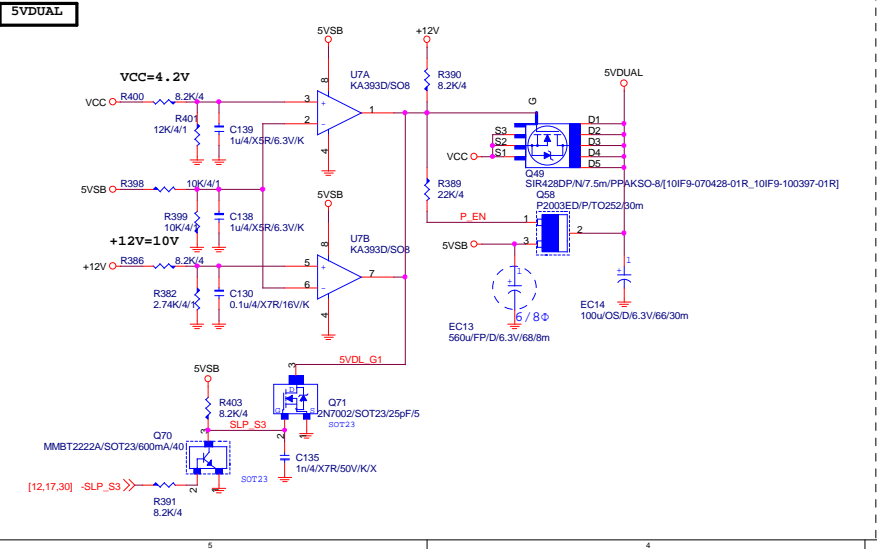
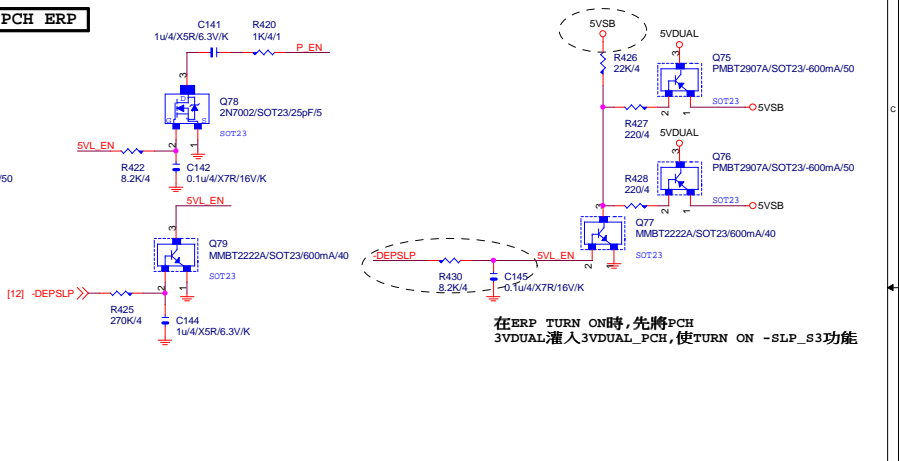
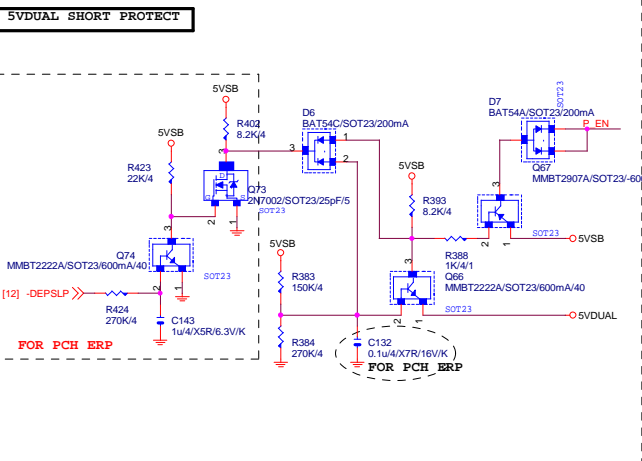
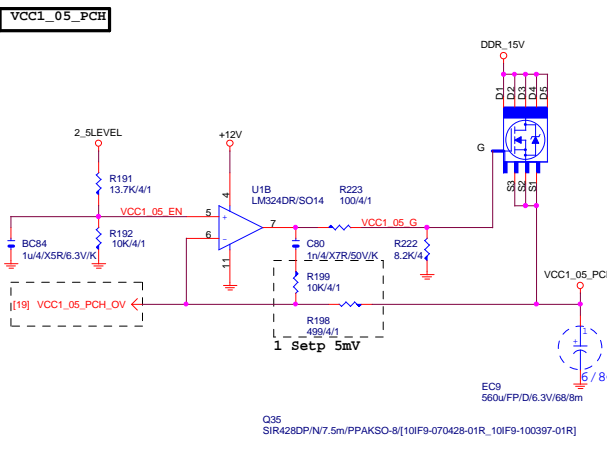
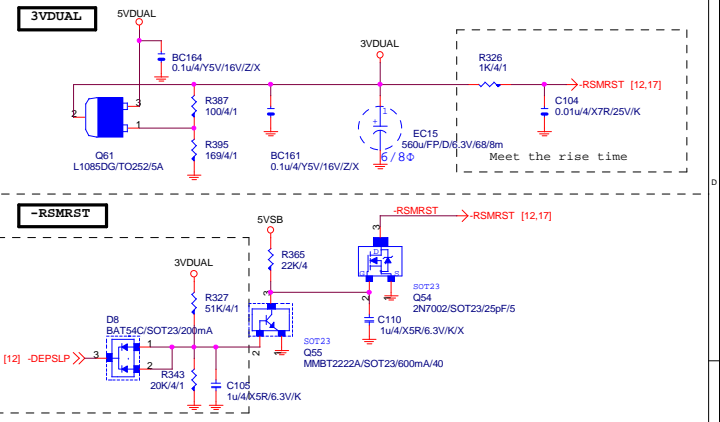
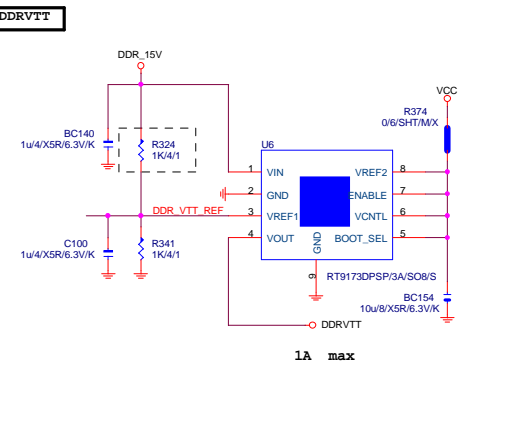
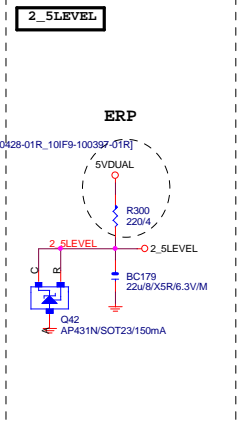
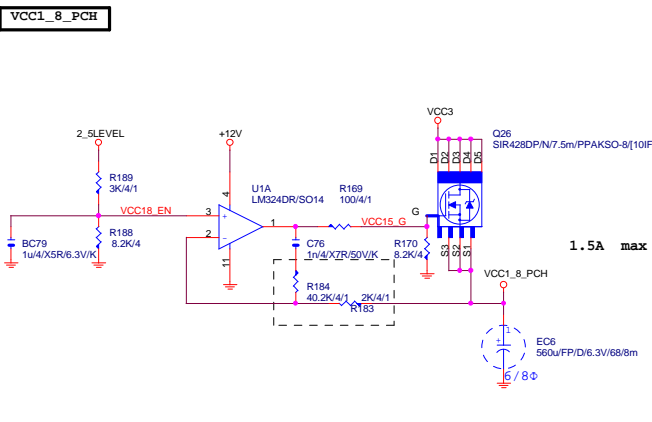

Gigabyte Technology		
DISCRETE POWER		
GA-B75M-D3H		
Rev	1.1	
Date:	Friday, June 08, 2012	Sheet 25 of 33

### ATXX24 POWER CONNECTOR

#### ATXPWR\_24-6

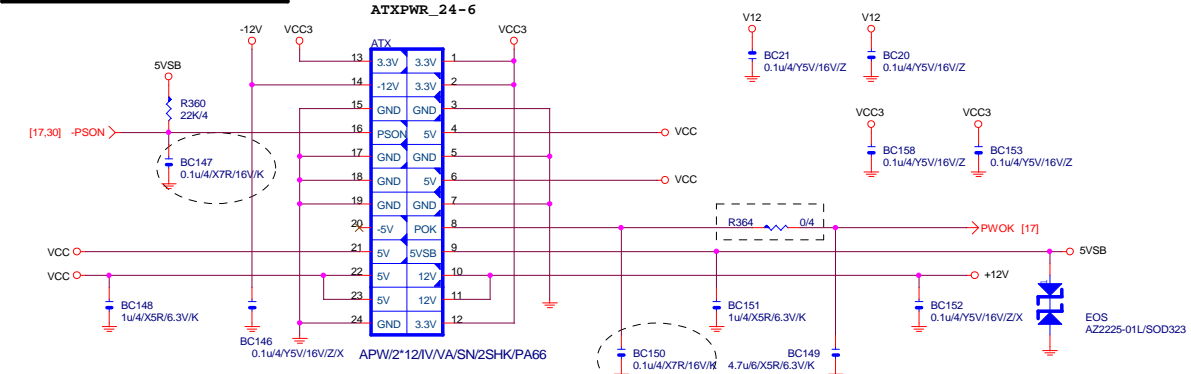

### ATXX4 POWER CONNECTOR

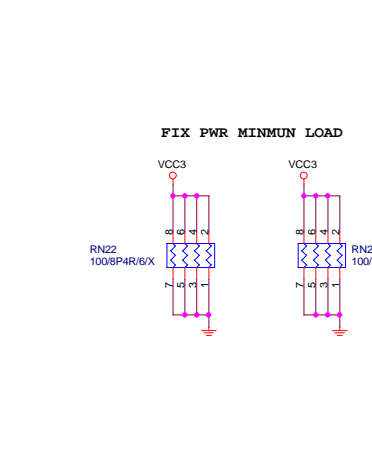
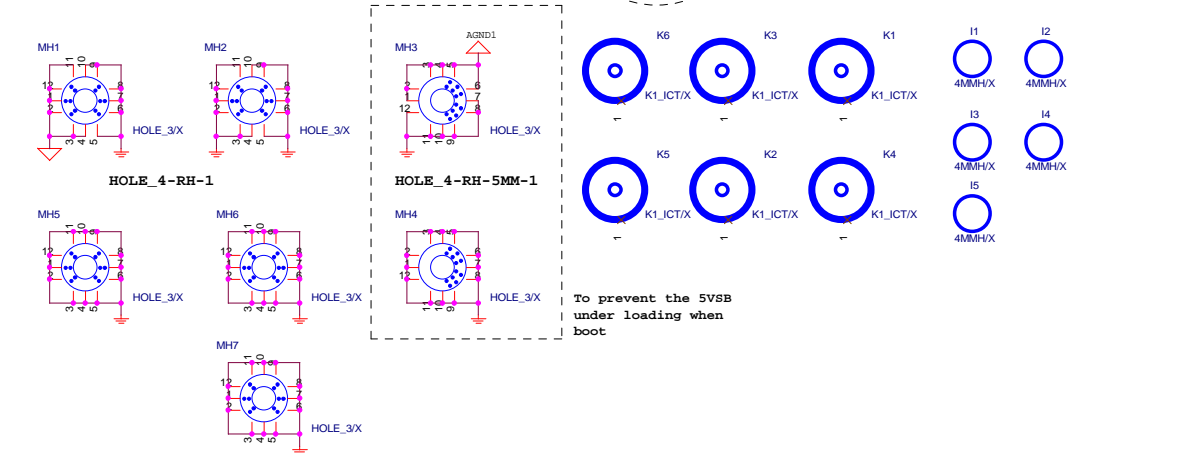
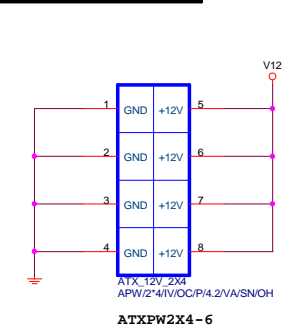

### CLK GEN

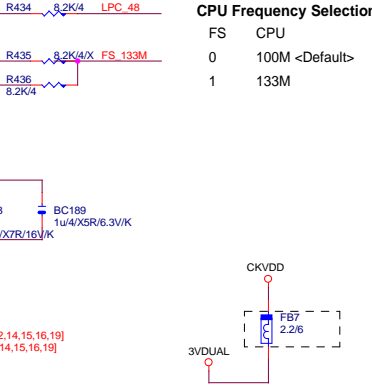
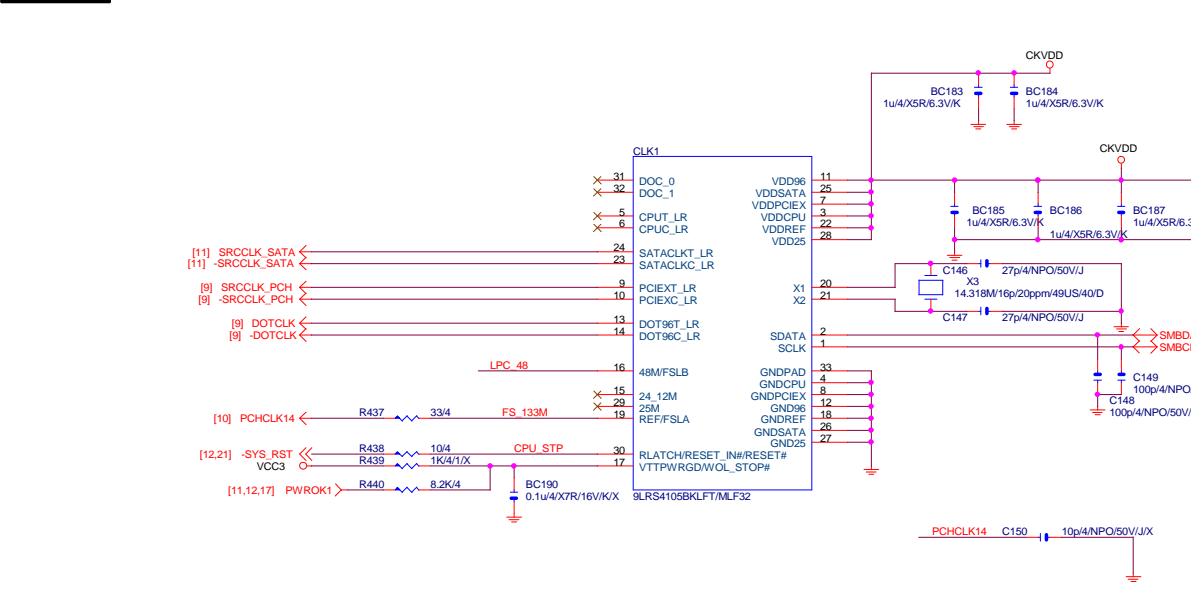

**Gigabyte Technology**

**ATX CONNECTOR**

**GA-B75M-D3H**

Rev 1.1

Date: Friday, June 08, 2012 Sheet 26 of 33

**CPU\_VTT**

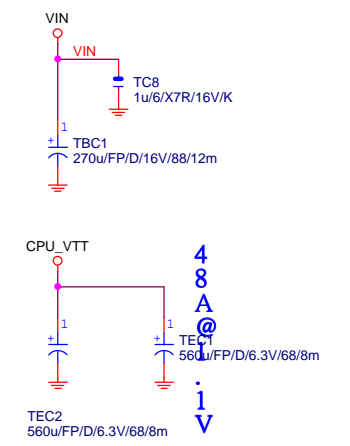
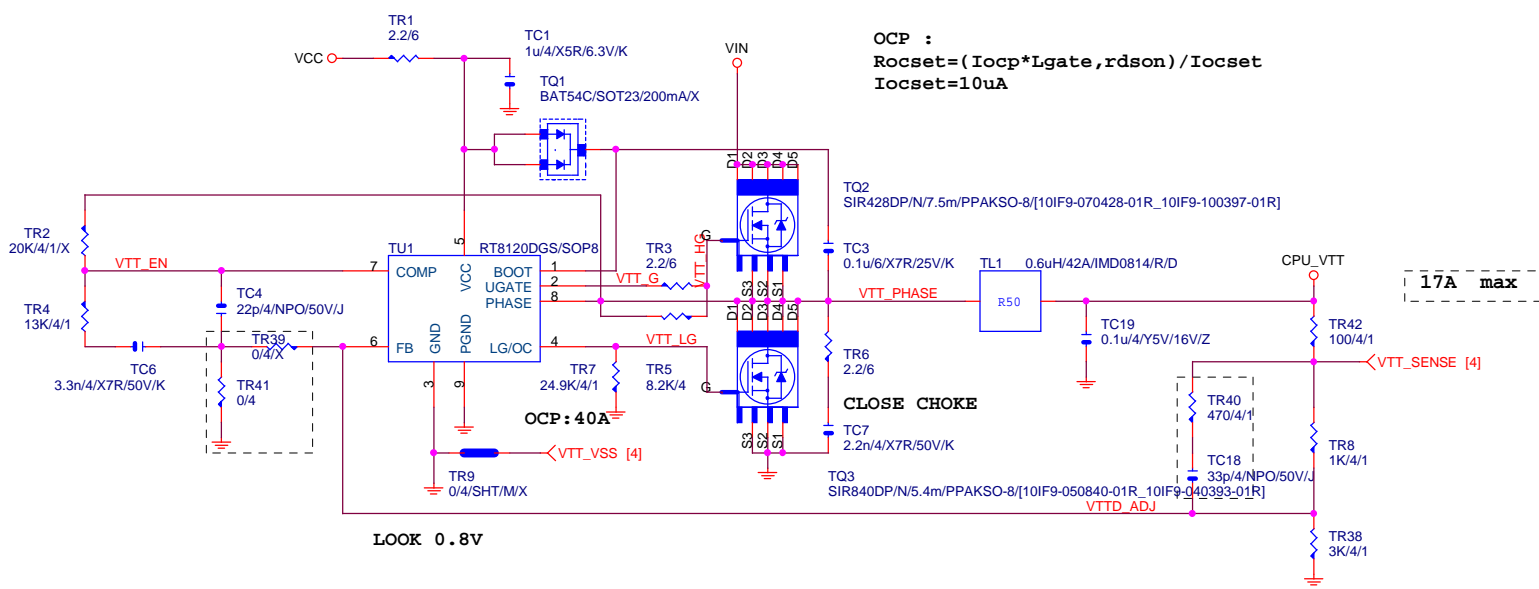

**VCCSA**

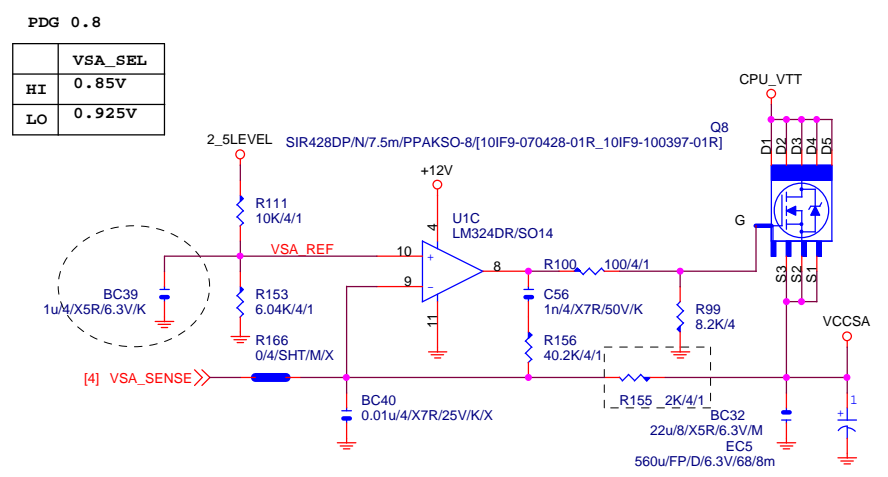

**CPU\_VTT PWR SEQ**

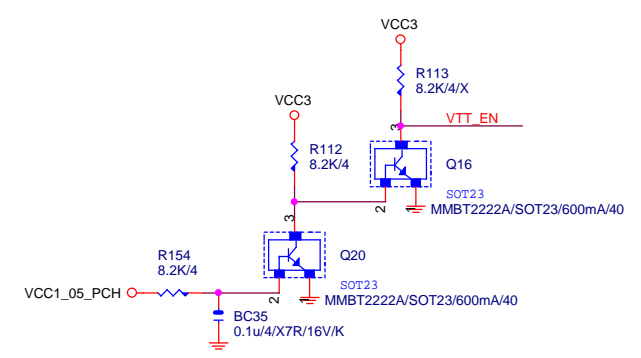

**VTT\_PWRGD**

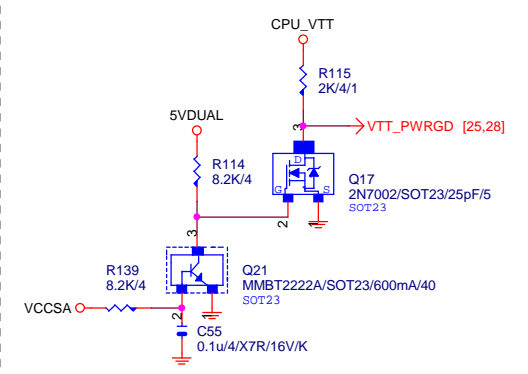

**GIGABYTE™**

Title: **CPU\_VTT PWM\_ISL95870CRZ**

Size: Custom Document Number: **GA-B75M-D3H** Rev: **1.1**

Date: Friday, June 08, 2012 Sheet 27 of 33

Intersil Original Design

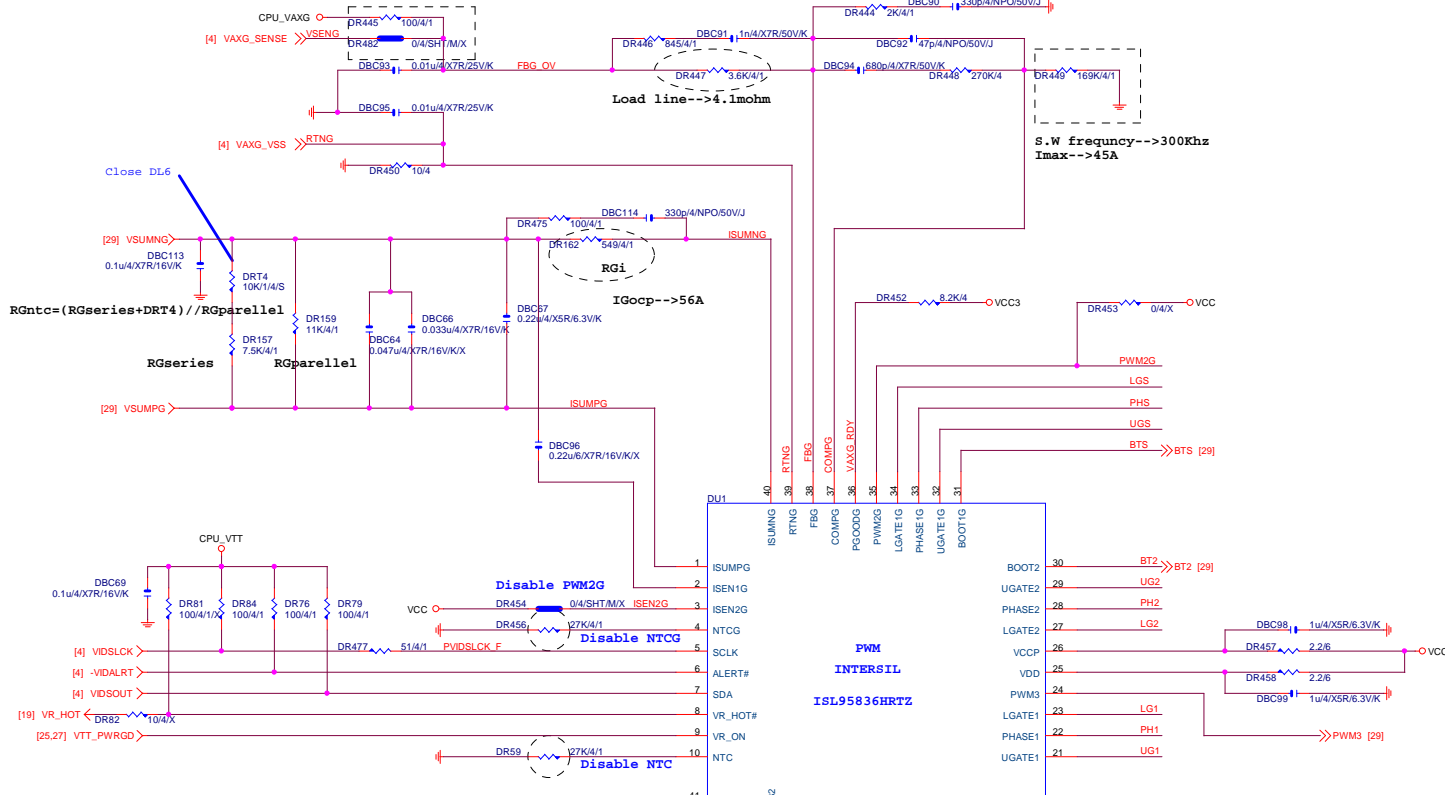

Close DL6

[29] VSUMNG  
0.1u/4/X7R/16VK

$R_{Gntc} = (R_{Gseries} + DRT4) // R_{Gparallel}$

[29] VSUMPG

CPU\_VTT  
[4] VDSLCK  
[4] -VIDALRT  
[4] VIDSOUT  
[19] VR\_HOT  
[25,27] VTT\_PWRGD

BOTTOM PAD CONNECT TO GND THROUGH 10 VIA

Close DL2

$R_{ntc} = (R_{series} + DRT3) // R_{parallel}$

[29] VSUMN

Load line-->1.7mohm

Intersil Original Design

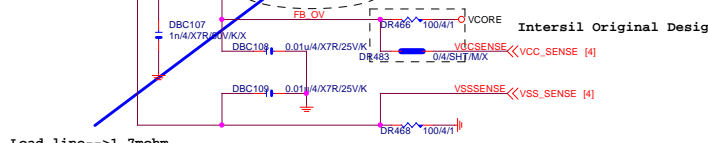

LAYOUT RESERVE CHOKE SPACE

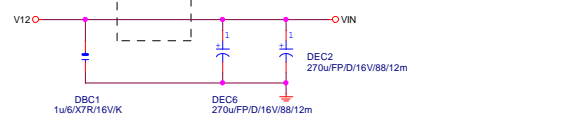

- UG1 → UG1 [29]
- PH1 → PH1 [29]
- LG1 → LG1 [29]
- ISEN1 → ISEN1 [29]
- UG2 → UG2 [29]
- PH2 → PH2 [29]
- LG2 → LG2 [29]
- ISEN2 → ISEN2 [29]
- UG3 → UG3 [29]
- PH3 → PH3 [29]
- LG3 → LG3 [29]
- ISEN3 → ISEN3 [29]

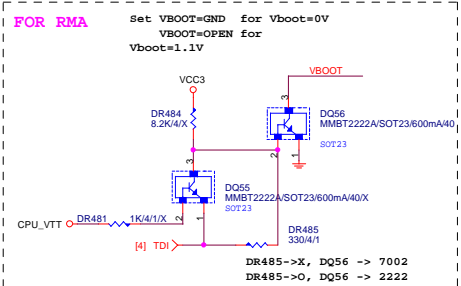
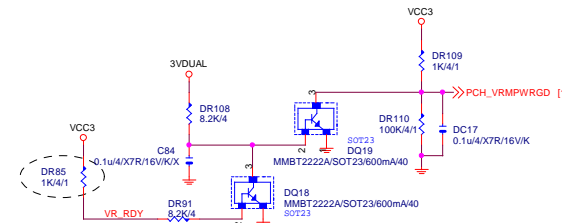

FOR RMA

Set VBOOT=GND for Vboot=0V  
VBOOT=OPEN for Vboot=1.1V

Vboot-->0V  
Imax-->99A

DR485->X, DQ56 -> 7002  
DR485->O, DQ56 -> 2222

Gigabyte Technology	
CPU CORE VR-1	
GA-B75M-D3H	
Size Custom	Document Number
Date Friday, June 08, 2012	Sheet 28 of 33

**PHASE 1**

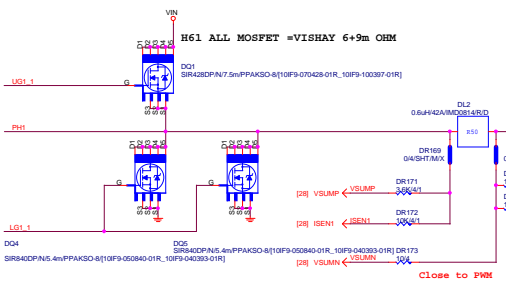
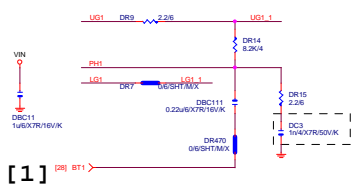
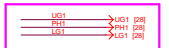

**PHASE 3**

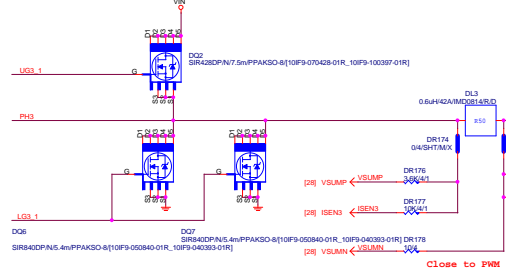
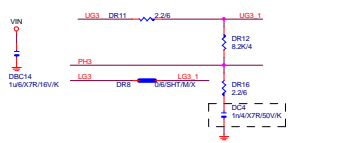
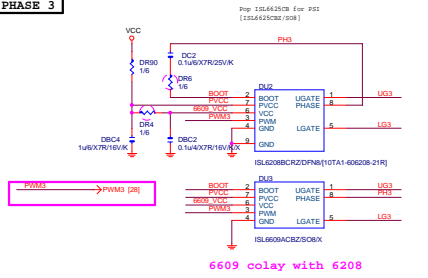

**PHASE 2**

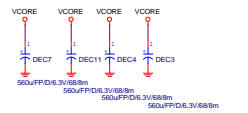
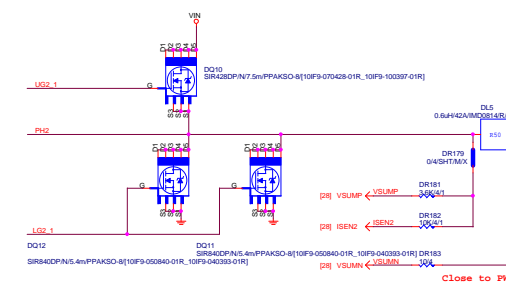
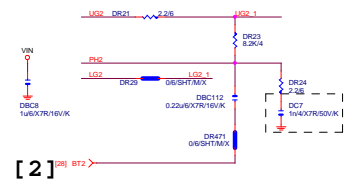
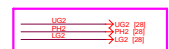

**VAXG**

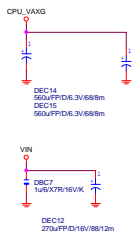
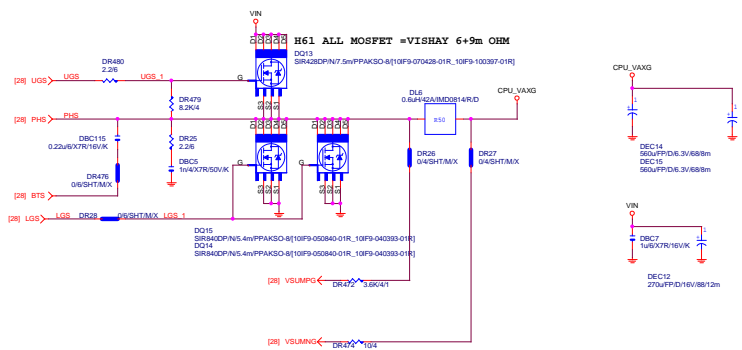



**DDR1.5V**

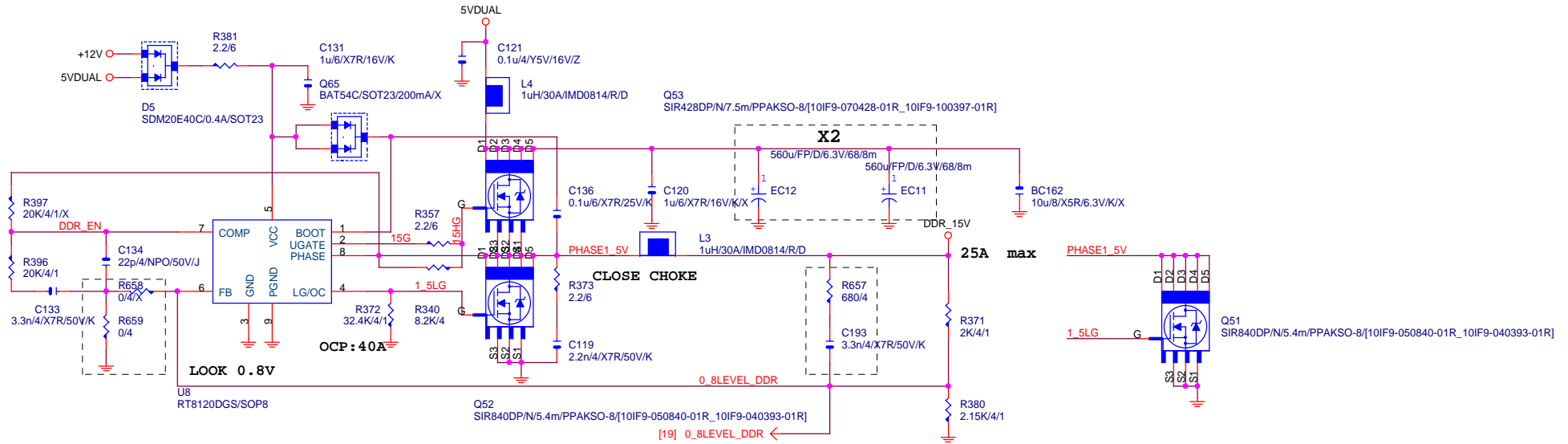

**PWR\_SEQ**

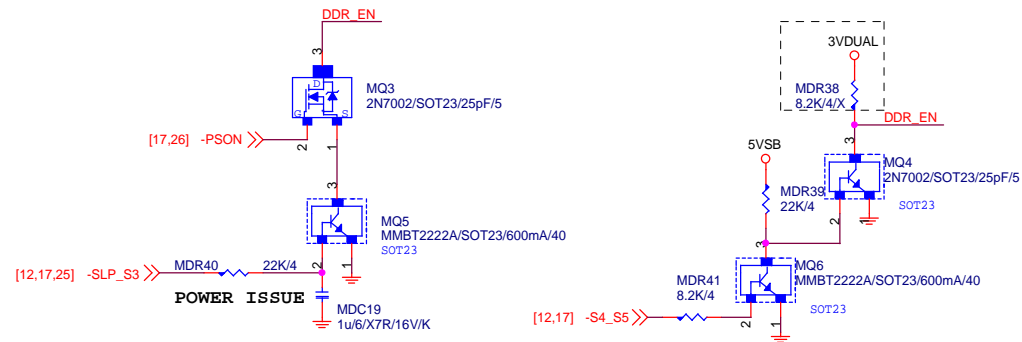

VIN=5V, VOUT=1.5V, IOU=25A, PHASE=1  
 IRMS=11.45A  
 560u/FP/D/6.3V/68/8m RIPPLE CURRENT=4.7A  
 Coefficient=1.7(85°C), 1(105°C)  
 VIN Ripple current=4.7x1.7=7.99A(85°C)  
 -->故固態電容須2x7.99=15.98>11.45A

OCp : Ipeak=(2xIocsetxRocset)/Rdson  
 typ Iocset=20uA , Rocset=4.7k  
 OCp : 53.71A=(2x20uax4.7k)/(7m//7m)

**Gigabyte Technology**

Title		
<b>DDR POWER</b>		
Size Custom	Document Number	Rev
	<b>GA-B75M-D3H</b>	<b>1.1</b>
Date:	Friday, June 08, 2012	Sheet 30 of 33

**TPM**

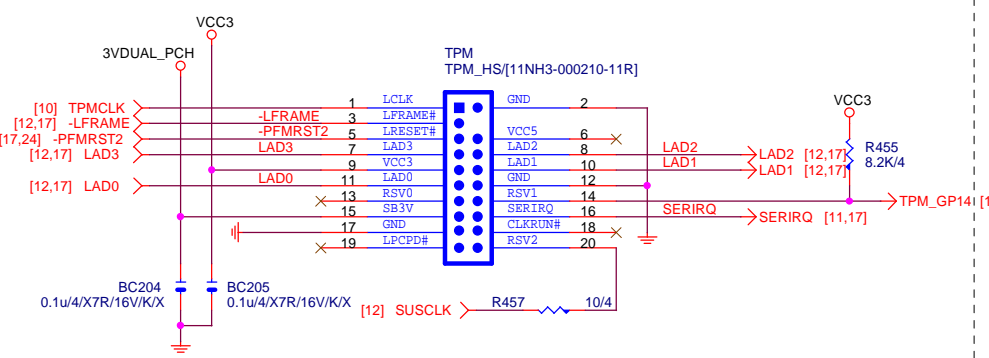

**VCC1\_05\_ME**

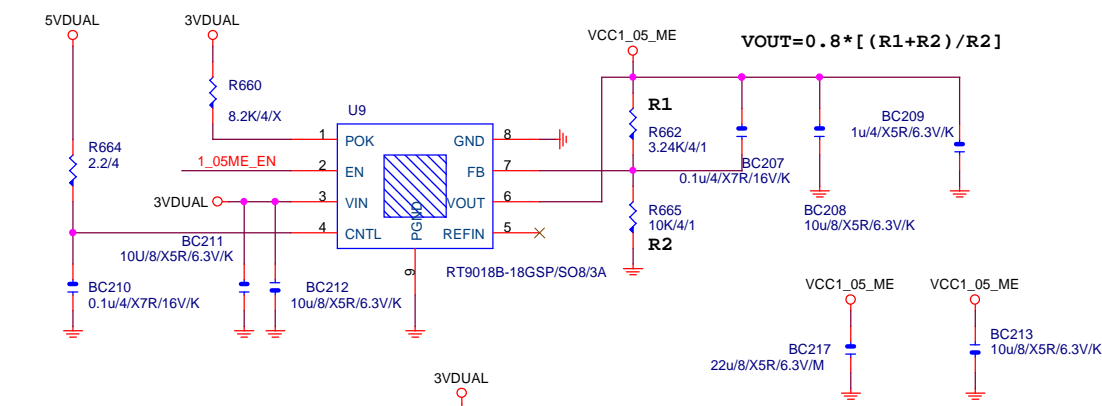

**LPT PORT**

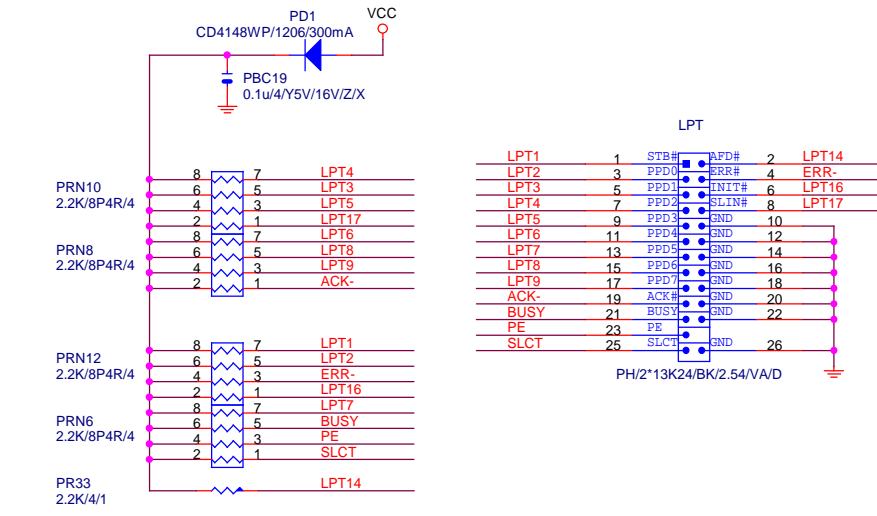
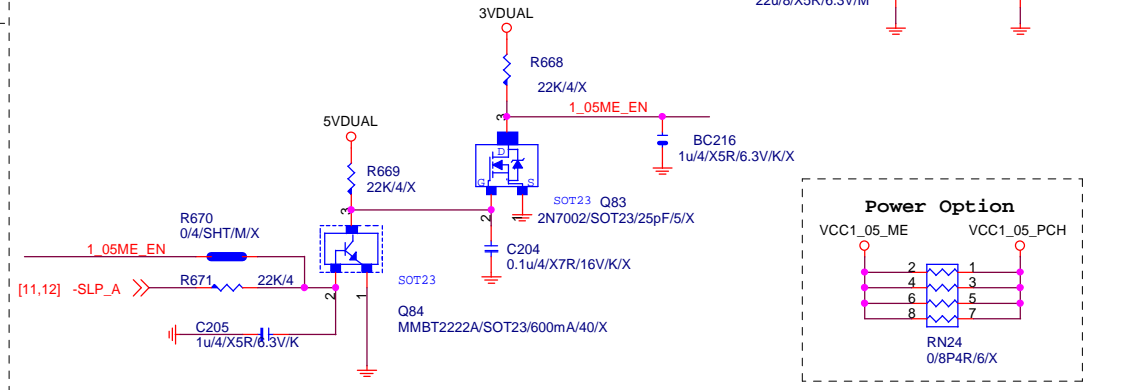
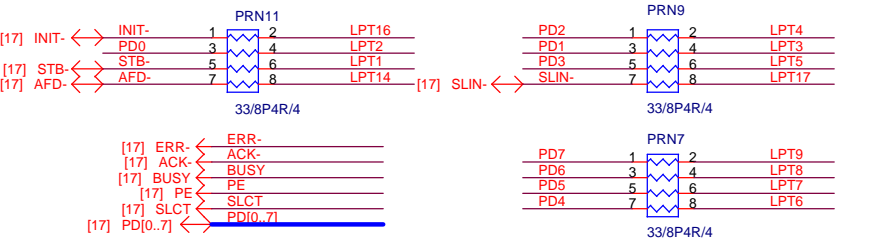

**VCC3\_ME**

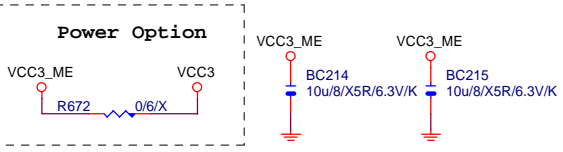
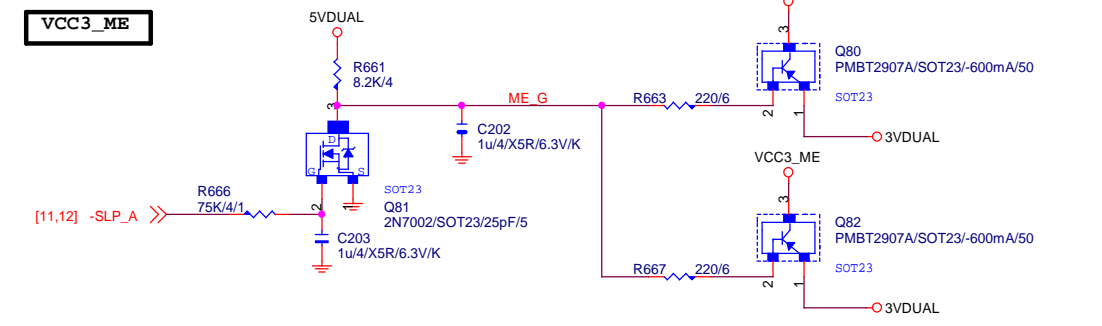

**Gigabyte Technology**

Title			<b>LPT</b>		
Size	Document Number	Rev			
Custom	<b>GA-B75M-D3H</b>	<b>1.1</b>			
Date:	Friday, June 08, 2012	Sheet	31	of	33

**DVI LEVEL SHIFT**

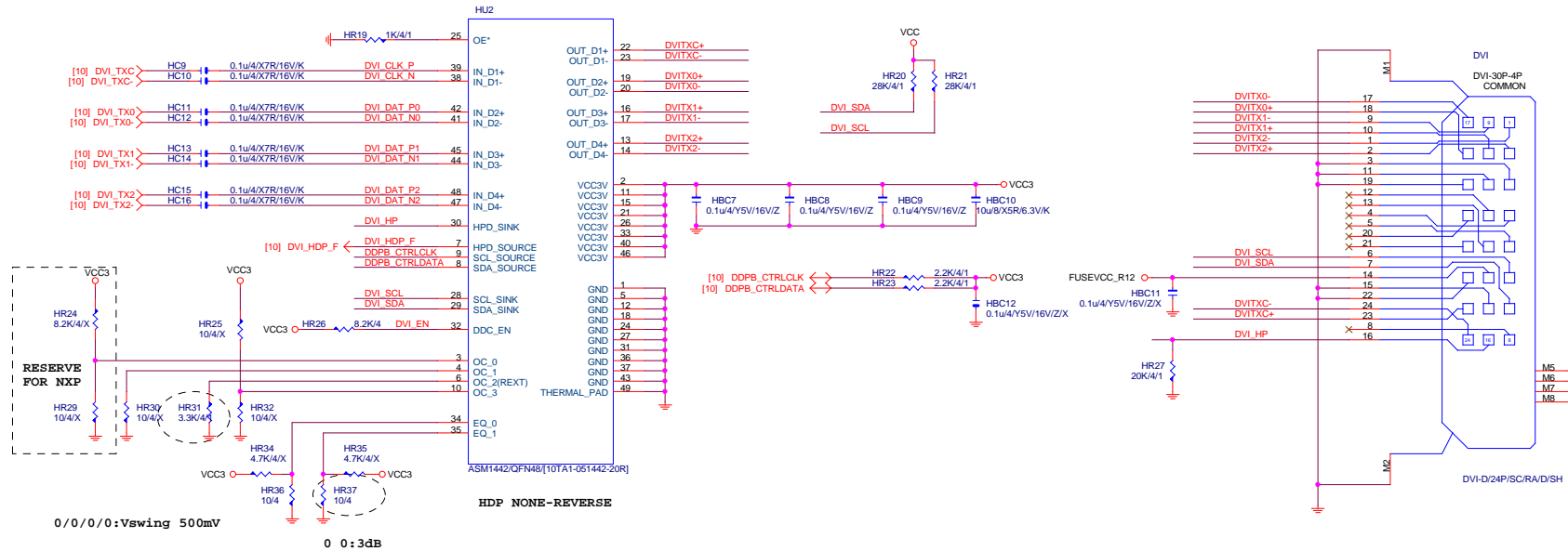

**HDMI LEVEL SHIFT**

