

X*TAL
14.318MHz

CLOCK GEN
ICS9LPR358AGLFT
2

Merom Processor
(Dual-Core)
uFCPGA 478
3, 4

FSB
(667/800 MHz)

SO-DIMM
11, 12

DUAL CHANNEL
DDR II 533/667 MHz

Crestline
GM965/PM965
5, 6, 7, 8, 9, 10

Using RP choice
GMPM

CRT
21

LCD
21

Inverter
21

ATI M74M
512MB
13, 14, 15, 16, 17, 18, 19

Using capacitors switch
965GM or 965PM

VRAM
512MB
18

Using RP choice
GMPM

HDMI connector
20

Si11392
HDMI
20

USB 1
port0 31

USB 2
port1 31

USB 3
Daughter Board CN
port5 31

Cardreader
RTS5158
port3 28

BlueTooth 2.0
BCM2045DX
port7 26

WebCam
port8 26

FingerPrinter
port9 26

RJ45
30

RTL8101E-GR
LAN
30

WLAN
MiniCard
port4 29

MINI-PCI-E
MiniCard
port2 29

ExpressCard
port6 29

ICH8M
22, 23, 24, 25

SATA
26

HDD
26

PATA
26

ODD
26

HDA

SigmaTel STAC9205
AUDIO CODEC
32

MAX9789A
AMP
33

Speaker

Headphone SPDIF
32

Microphone
32

MDC
29

RJ11

X*TAL
24MHz

DNP-FW322-100
1394a
27

SPI
34

W83L951D
KBC
34

Lid Switch
21

LEDs
32

PWR Button
34

Keyboard
34

Touchpad
34

System Power Rail Management

	SLP S3#	SLP S4#	SLP S5#	S4 STATE#	*VSTBY	*V	*VS	Clocks
S0 (Full ON)	HIGH	HIGH	HIGH	HIGH	ON	ON	ON	ON
S3 (Suspend to RAM)	LOW	HIGH	HIGH	HIGH	ON	ON	OFF	OFF
S4 (Suspend to Disk)	LOW	LOW	HIGH	LOW	ON	OFF	OFF	OFF
S5 (Soft OFF)	LOW	LOW	LOW	LOW	ON	OFF	OFF	OFF

AC-IN/Charger
35

VCORE
36

3VSTBY/5V
37

1.05V/1.8V
38

0.9VS/3VSTBY
39

1.5V/1.25V
39

Graph-VID/1.1V
40

PWR Good
41

Standby PWR
41

Screw Hole UnuseGate
42

PWR Sequence
43

Release Note
44

	W350UI1 / W650UI1	W350DI1 / W650DI1
NB	10-0010000029G IC GM965 SLA5T NORTHBRIDGE BGA1299	10-0010000030G IC PM965 SLA5U NORTHBRIDGE BGA1299
SB	10-0010000031G IC ICH8M SLA5Q SOUTHBRIDGE BGA-676	10-0010000031G IC ICH8M SLA5Q SOUTHBRIDGE BGA-676

Build BOM NOTE:
 UI1&DI1 DIFFERENT at PAGE 2.5-10.13-19.21.35.34.40.41
 UI1 DEL PAGE 13.14.15.17.18.19(RIGHT PART)
 DI1 DEL PAGE 19(LEFT PART).PAGE 20
 With HDMI or Without HDMI at PAGE 20.21
 W350&W650 DIFFERENT at PAGE 21.22.26.34

UN-USE OPTION

Arima ARIMA COMPUTER CORP.

Project Name: **W350DI** Title: BLOCK Diagram

Size: Document Number: 40GAB1700-E110 Rev: E

Date: Thursday, June 21, 2007 Sheet: 1 of 44

CLK GEN

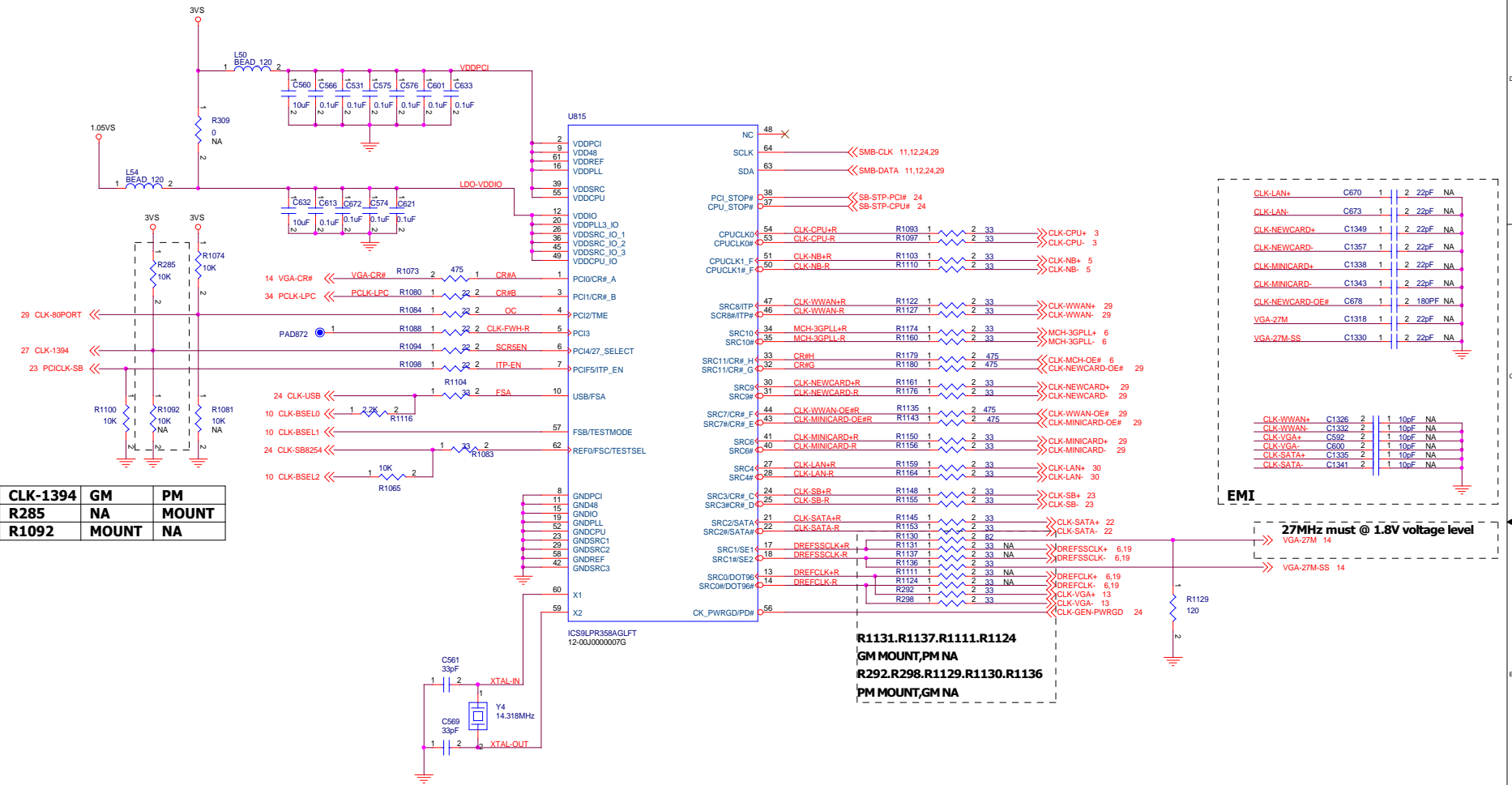

CLK-1394	GM	PM
R285	NA	MOUNT
R1092	MOUNT	NA

Component	Value	Part	Mount	Notes
C1306	2 22pF	NA	PCICLK-SB	
C1278	2 22pF	NA	PCLK-LPC	
C1303	2 22pF	NA	CLK-1394	
C1285	2 22pF	NA	CLK-SB8254	
C1313	2 22pF	NA	CLK-USB	
C1289	2 22pF	NA	CLK-80PORT	

Signal	Component	Value	Part	Mount	Notes
CLK-LAN+	C670	1	2 22pF	NA	
CLK-LAN-	C673	1	2 22pF	NA	
CLK-NEWCARD+	C1349	1	2 22pF	NA	
CLK-NEWCARD-	C1357	1	2 22pF	NA	
CLK-MINICARD+	C1338	1	2 22pF	NA	
CLK-MINICARD-	C1343	1	2 22pF	NA	
CLK-NEWCARD-OE#	C678	1	2 180pF	NA	
VGA-27M	C1318	1	2 22pF	NA	
VGA-27M-SS	C1330	1	2 22pF	NA	

Signal	Component	Value	Part	Mount	Notes
CLK-WWAN+	C1326	2	1 10pF	NA	
CLK-WWAN-	C1332	2	1 10pF	NA	
CLK-VGA+	C592	2	1 10pF	NA	
CLK-VGA-	C600	2	1 10pF	NA	
CLK-SATA+	C1335	2	1 10pF	NA	
CLK-SATA-	C1341	2	1 10pF	NA	

EMI

27MHz must @ 1.8V voltage level
 VGA-27M 14
 VGA-27M-SS 14

R1131.R1137.R1111.R1124
 GM MOUNT,PM NA
R292.R298.R1129.R1130.R1136
 PM MOUNT,GM NA

CPU I/F

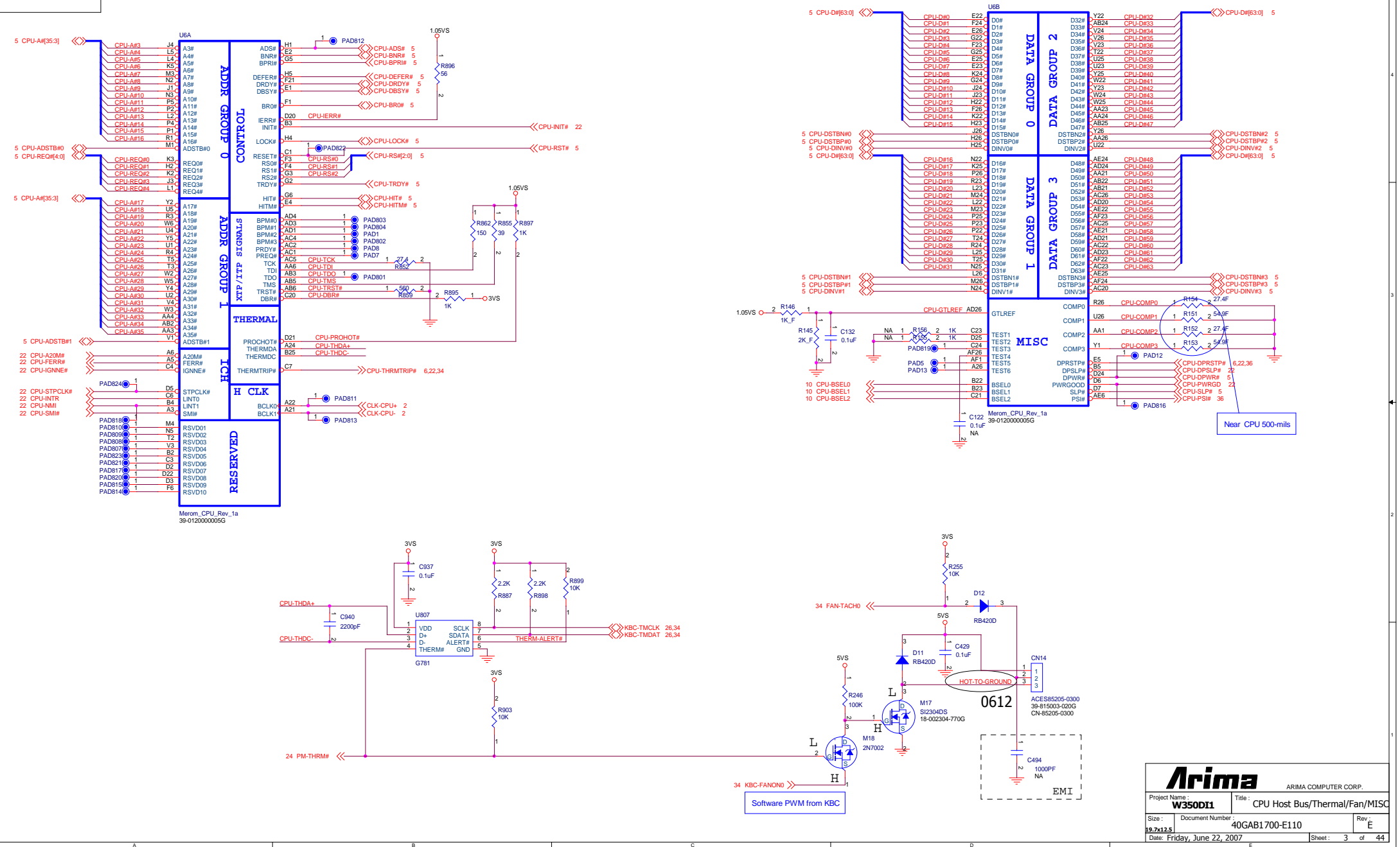

Arima		ARIMA COMPUTER CORP.	
Project Name:	W350D11	Title:	CPU Host Bus/Thermal/Fan/MISC
Size:	Document Number:	Rev:	E
19.7x12.5	40GAB1700-E110		
Date:	Friday, June 22, 2007	Sheet:	3 of 44

CPU PWR

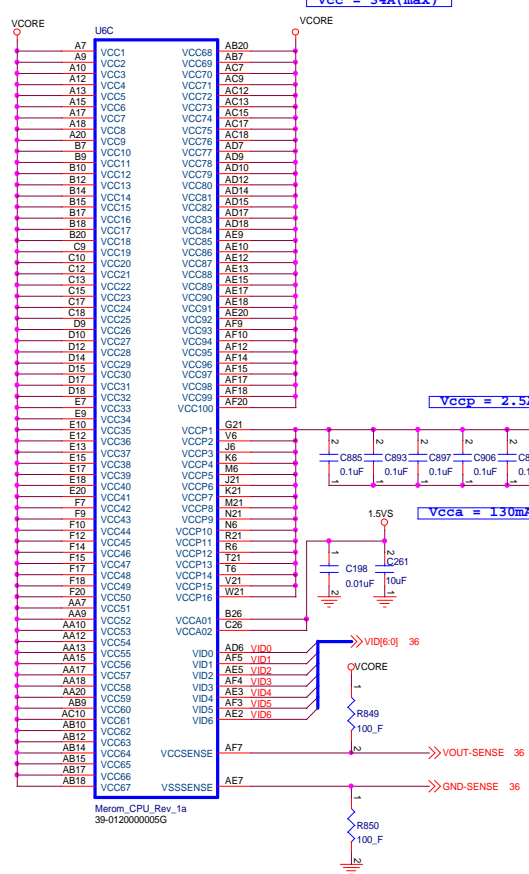
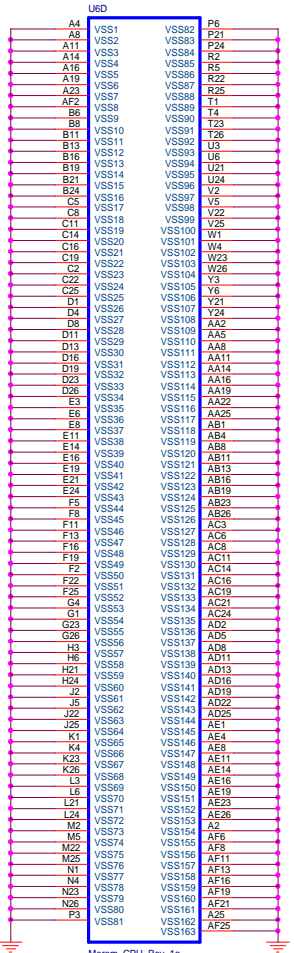

Vcc = 34A(max)

Vccp = 2.5A(max)

Vcca = 130mA(max)

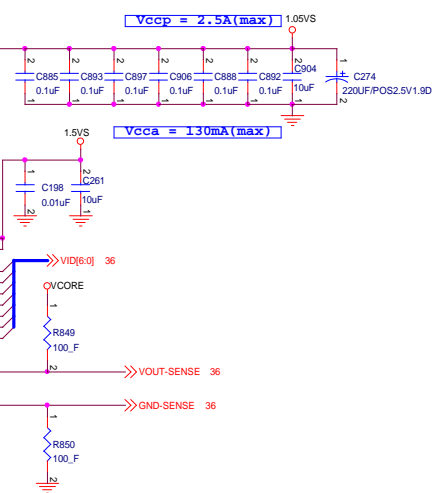
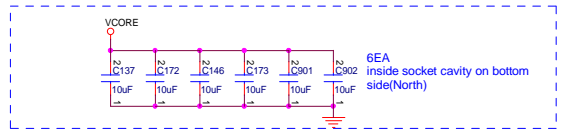
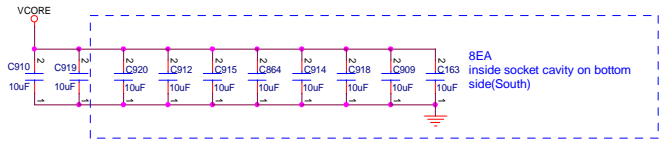
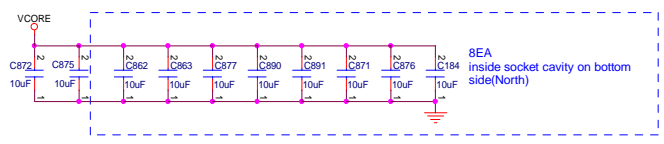

Arima		ARIMA COMPUTER CORP.	
Project Name:		Title:	
W350D11		CPU Power Rail / VCORE	
Size:	Document Number:	Rev:	
19.7x12.5	40GAB1700-E110	E	
Date: Thursday, June 21, 2007		Sheet: 4 of 44	

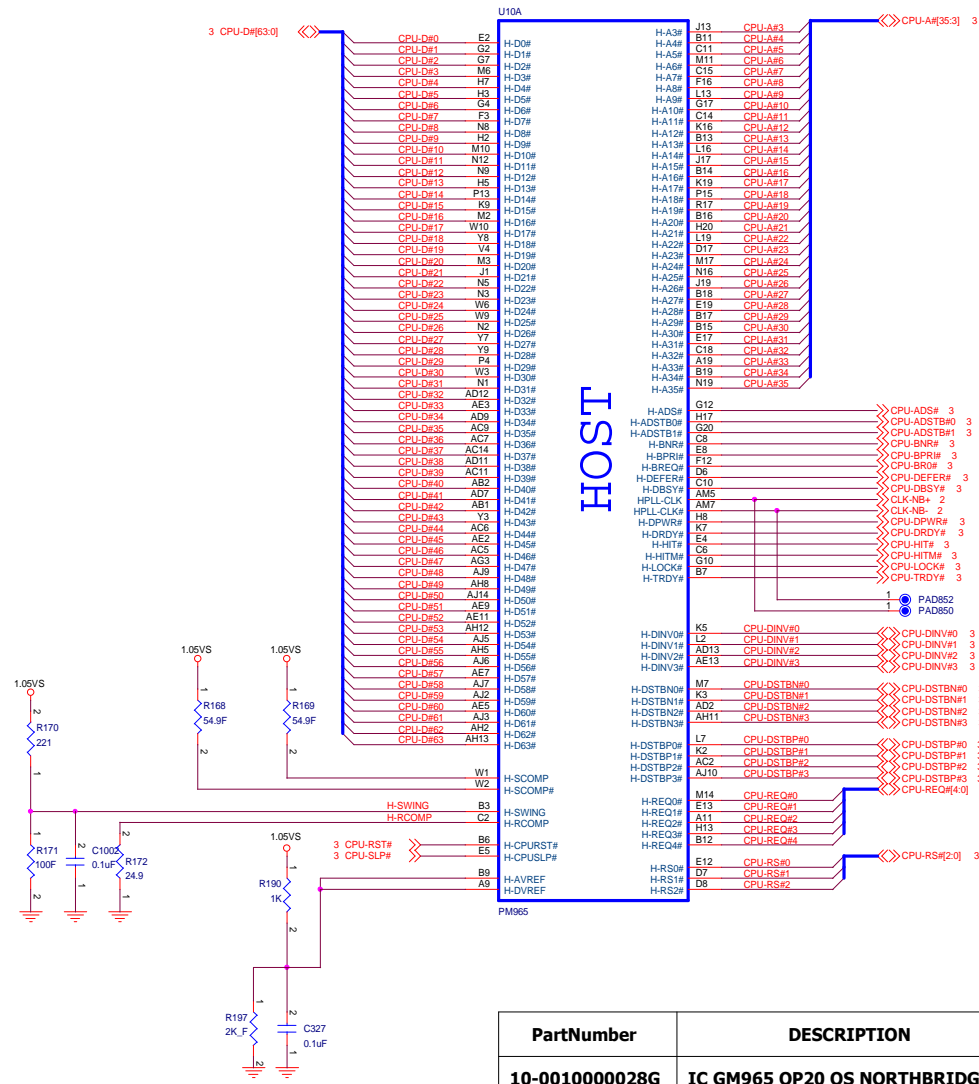

PartNumber	DESCRIPTION
10-0010000028G	IC GM965 QP20 QS NORTHBRIDGE BGA-1299
10-0010000027G	IC PM965 QP21 QS NORTHBRIDGE BGA-1299
10-0010000029G	IC GM965 SLAST NORTHBRIDGE BGA1299
10-0010000030G	IC PM965 SLA5U NORTHBRIDGE BGA1299

Arima ARIMA COMPUTER CORP.

Project Name: **W350D11** Title: **NB-Front Side Bus Interface**

Size: **19.7x12.5** Document Number: **40GAB1700-E110** Rev: **E**

Date: **Thursday, June 21, 2007** Sheet: **5** of **44**

NB DMI/Display/PCIE I/F

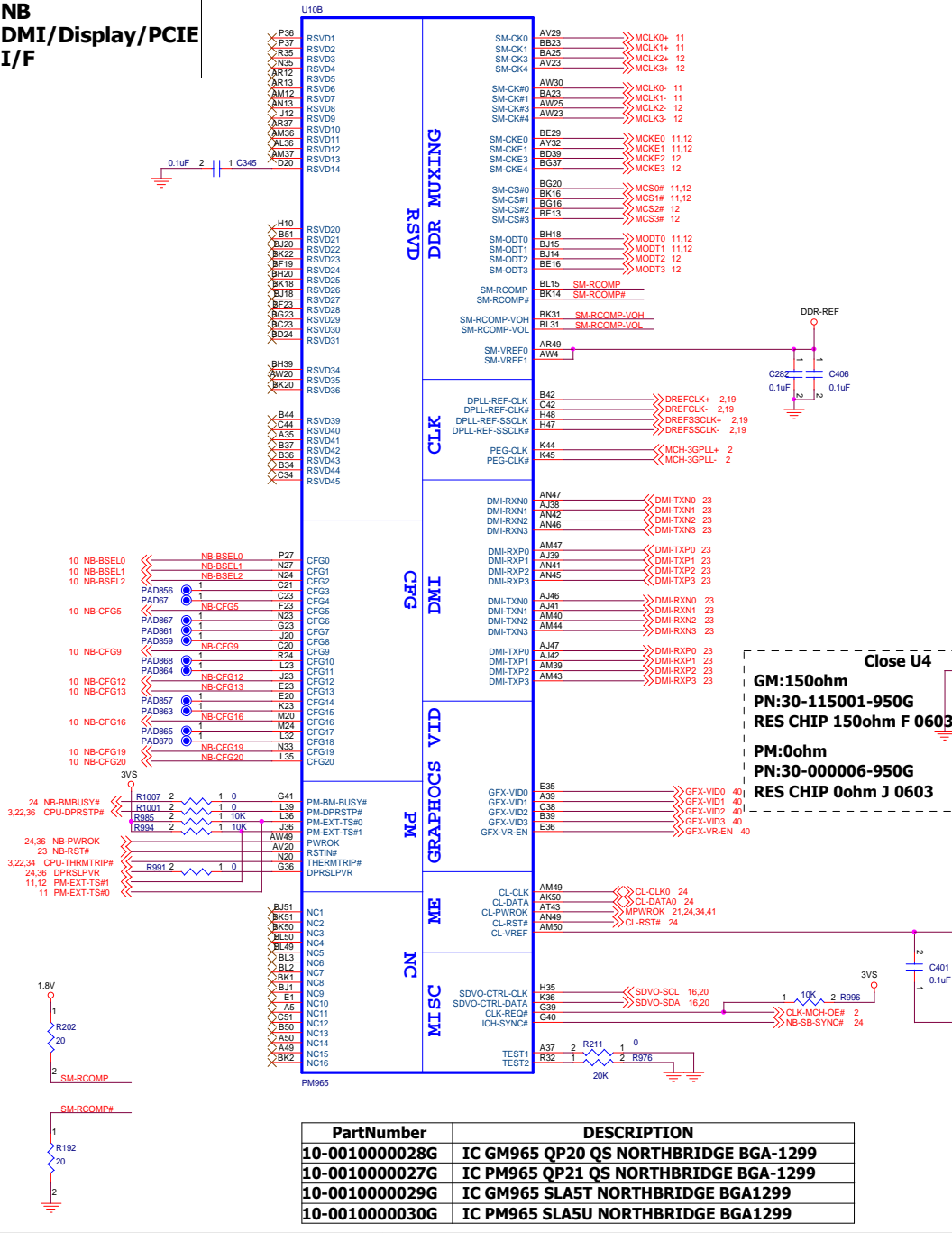

GM MOUNT PM NA

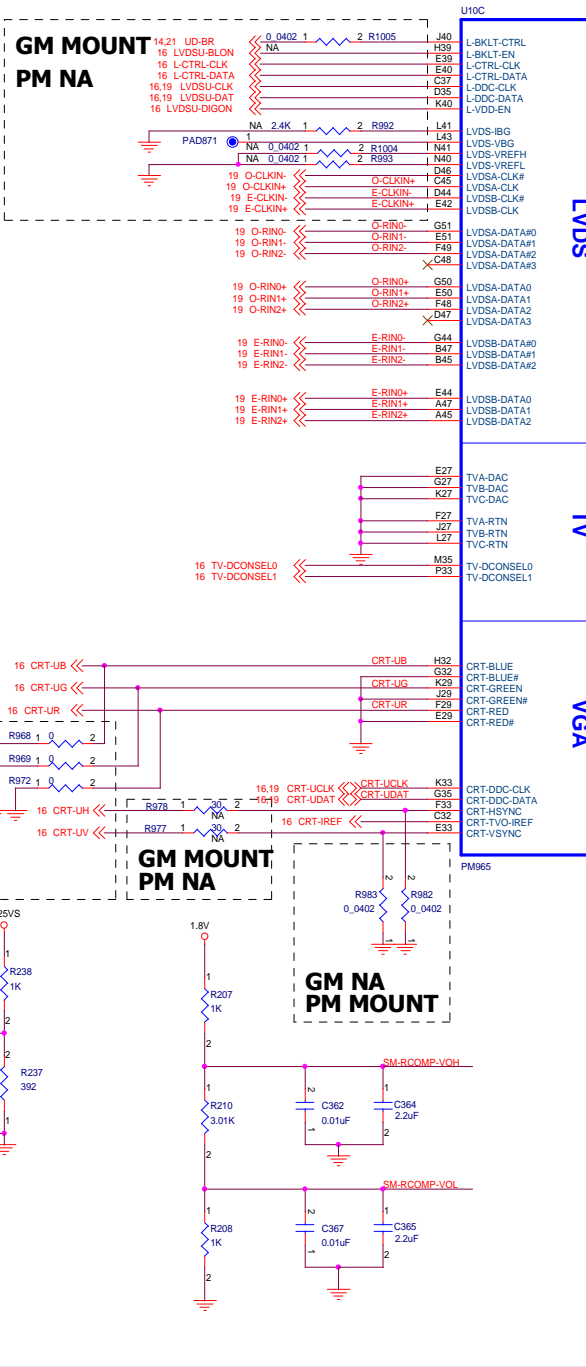

LVDS

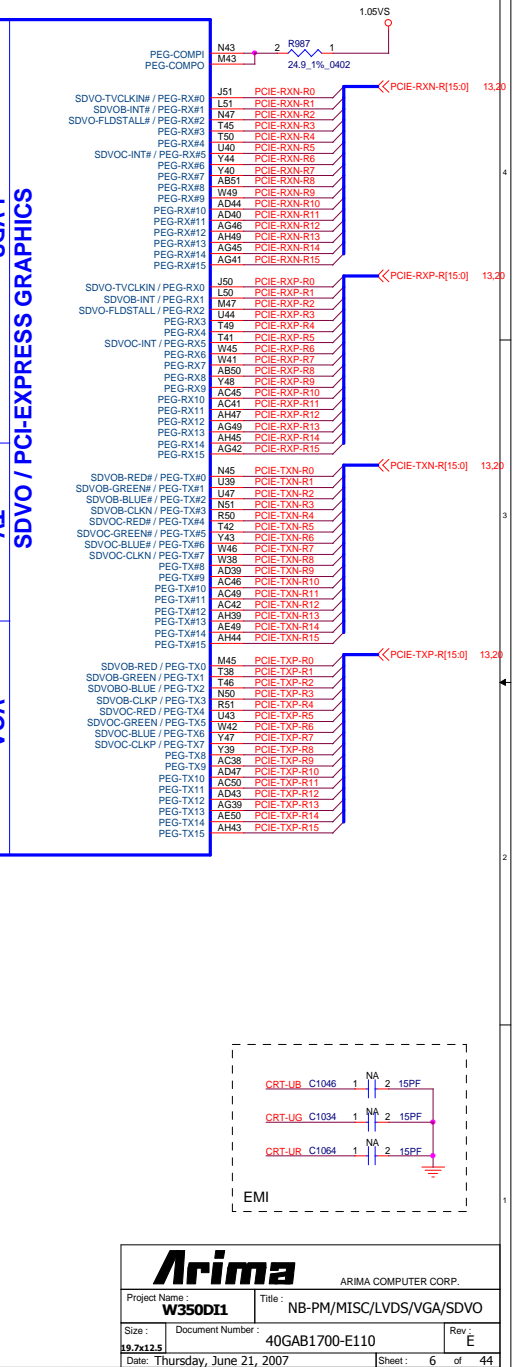

SDVO / PCI-EXPRESS GRAPHICS

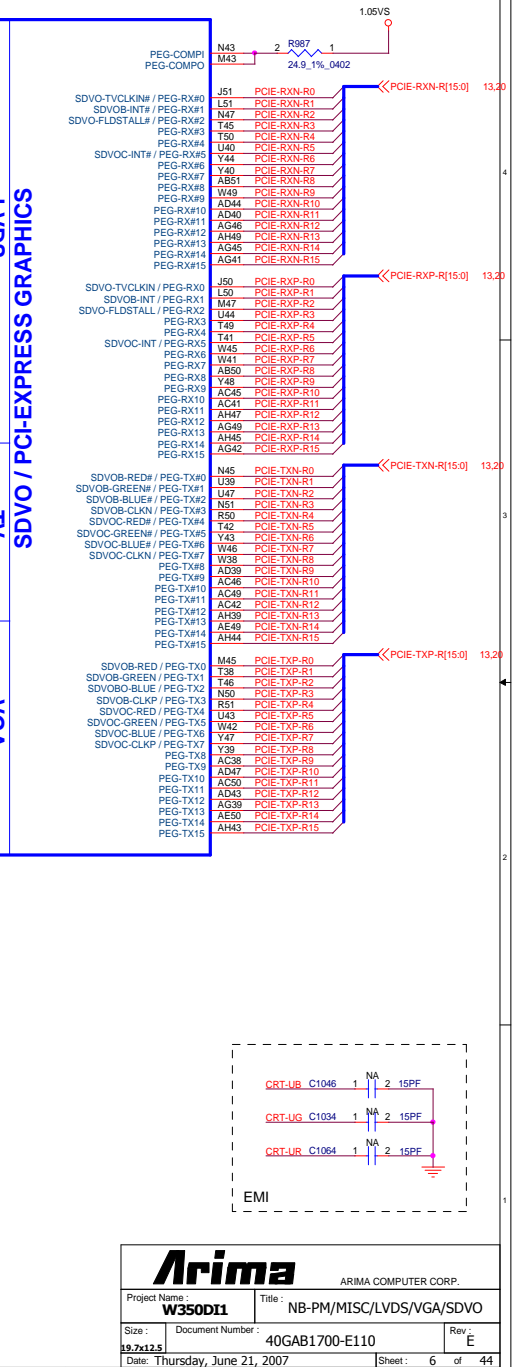

PartNumber	DESCRIPTION
10-0010000028G	IC GM965 QP20 QS NORTHBRIDGE BGA-1299
10-0010000027G	IC PM965 QP21 QS NORTHBRIDGE BGA-1299
10-0010000029G	IC GM965 SLA5T NORTHBRIDGE BGA1299
10-0010000030G	IC PM965 SLA5U NORTHBRIDGE BGA1299

<h3>Arima</h3>		ARIMA COMPUTER CORP.
Project Name: W350D1	Title: NB-PM/MISC/LVDS/VGA/SDVO	
Size: 19.7x12.5	Document Number: 40GAB1700-E110	Rev: E
Date: Thursday, June 21, 2007	Sheet: 6 of 44	

NB DDR2 I/F

NB GND

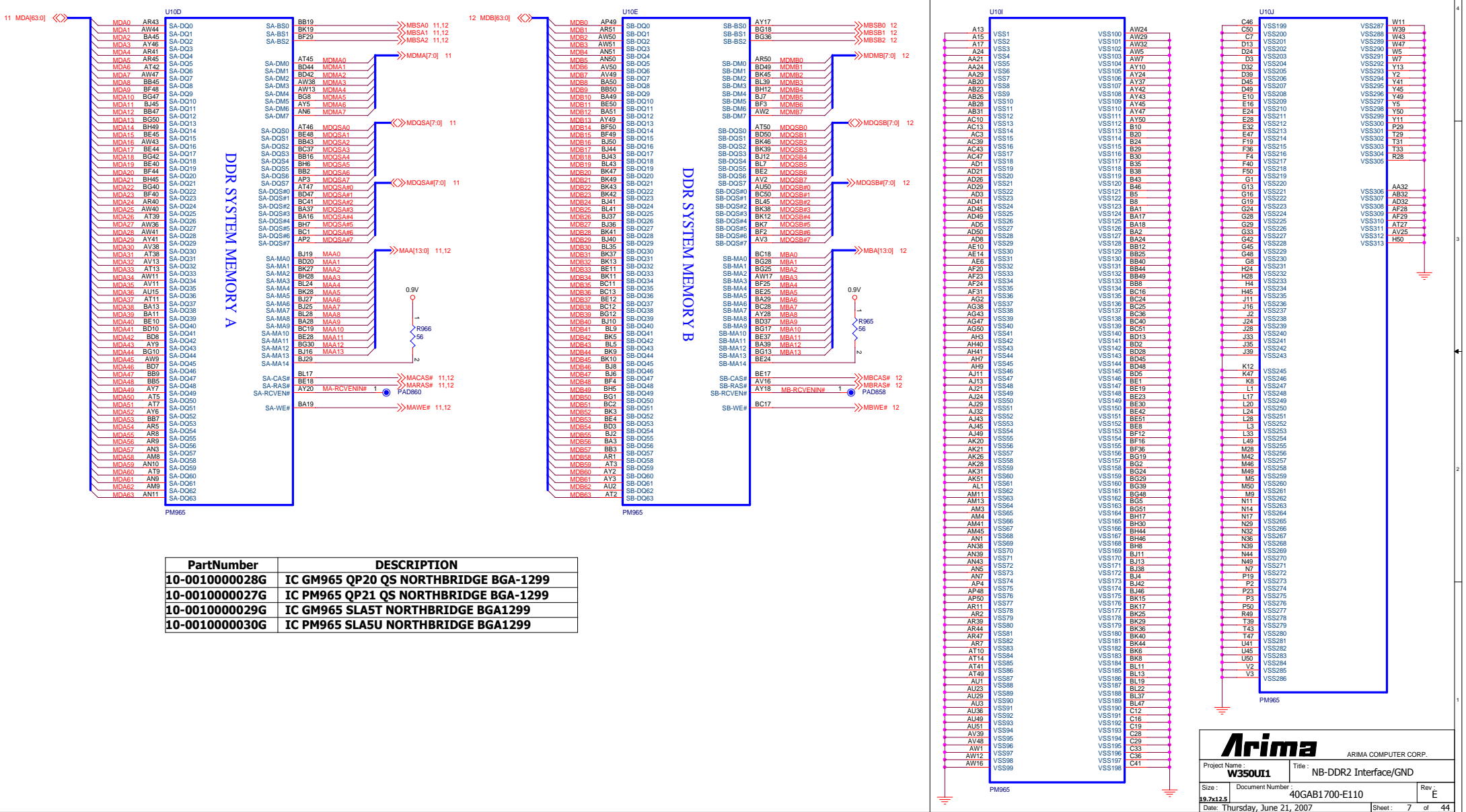

PartNumber	DESCRIPTION
10-0010000028G	IC GM965 QP20 QS NORTHBRIDGE BGA-1299
10-0010000027G	IC PM965 QP21 QS NORTHBRIDGE BGA-1299
10-0010000029G	IC GM965 SLA5T NORTHBRIDGE BGA1299
10-0010000030G	IC PM965 SLA5U NORTHBRIDGE BGA1299

ARIMA COMPUTER CORP.

Project Name: W350U1		Title: NB-DDR2 Interface/GND	
Size: 19.7x125	Document Number: 40GAB1700-E110	Rev: E	
Date: Thursday, June 21, 2007		Sheet: 7 of 44	

Core PWR

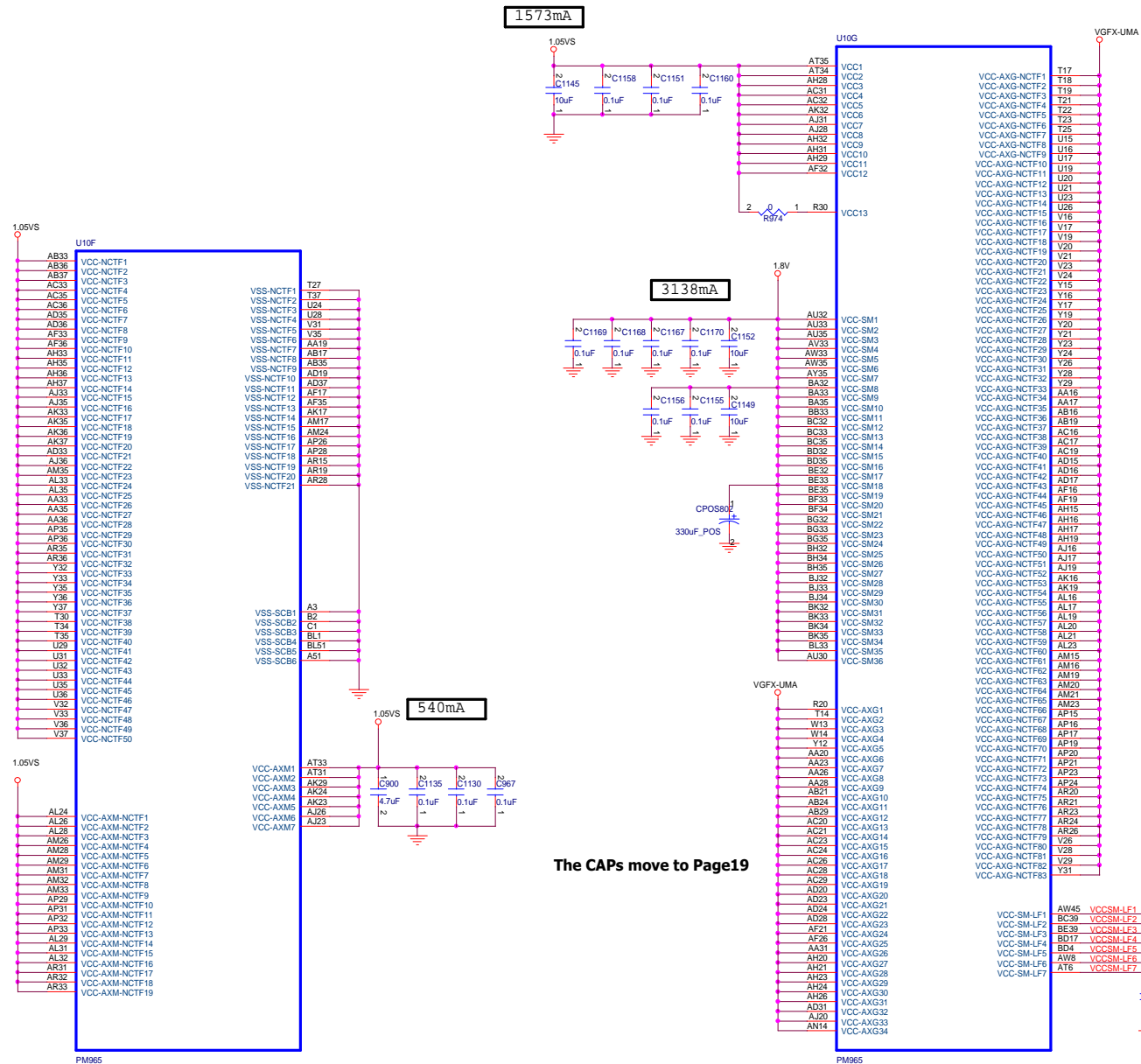

The CAPS move to Page19

PartNumber	DESCRIPTION
10-0010000028G	IC GM965 QP20 QS NORTHBRIDGE BGA-1299
10-0010000027G	IC PM965 QP21 QS NORTHBRIDGE BGA-1299
10-0010000029G	IC GM965 SLA5T NORTHBRIDGE BGA1299
10-0010000030G	IC PM965 SLA5U NORTHBRIDGE BGA1299

ARIMA COMPUTER CORP.

Project Name : W350D11		Title : NB-CorePWR/1.05V/1.8V/VGFX	
Size : 19.7x12.5	Document Number : 40GAB1700-E110	Rev : E	
Date : Thursday, June 21, 2007		Sheet : 9 of 44	

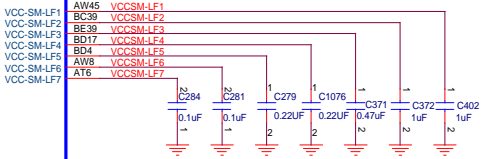

NB STRAP

CPU

FSC CLK-BSEL2	FSB CLK-BSEL1	FSA CLK-BSEL0	BCLK[2:0] Select
0	1	1	166MHz (DEFAULT)
0	1	0	200MHz

NB

CFG2 NB-BSEL2	CFG1 NB-BSEL1	CFG0 NB-BSEL0	FSB select
0	0	1	533MHz
0	1	1	667MHz
0	1	0	800MHz

CFG [19:18] has internal pull down

CFG [17:3] has internal pull up

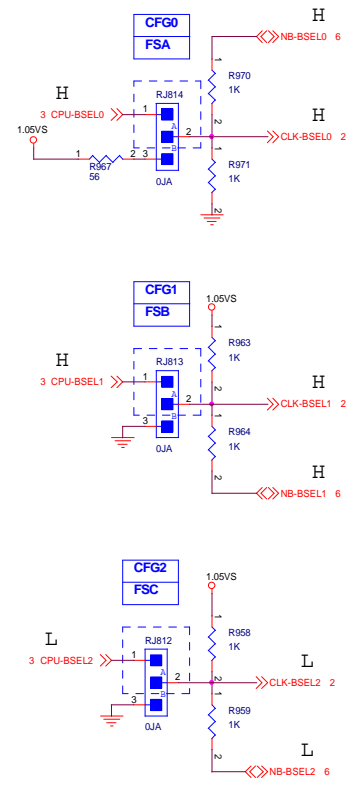

NB-CFG5 DMI x2 select	0=DMI x 2 1=DMI x 4(DEFAULT)
--------------------------	---------------------------------

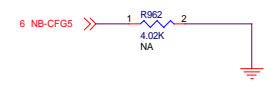

NB-CFG9 PCIe Graphics Lane	0= Reverse Lane 1= Normal (DEFAULT)
-------------------------------	--

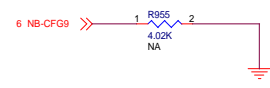

XOR / ALLZ / Clock Un-gating		
NB-CFG12	NB-CFG13	Configuration
0	0	Clock Gating Disable
0	1	XOR Mode Enable
1	0	All-2 Mode Enable
1	1	Normal Operation (Default)

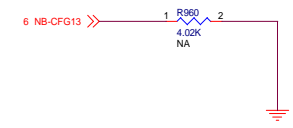

NB-CFG20	0= Only SDVO or PCIe X1 is operational(DEFAULT) 1= SDVO & PCIe X1 are operating simultaneously via the PEG port
----------	--

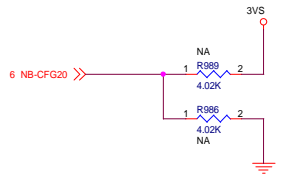

NB-CFG16	0= Dynamic ODT Disabled 1= Dynamic ODT Enabled(DEFAULT)
----------	--



NB-CFG19	DMI Lane 0=Normal (DEFAULT) 1= Lan Reversed
----------	---

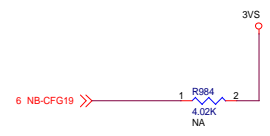

Arima			ARIMA COMPUTER CORP.
Project Name : W350D11		Title : NB-Strapping/CLK-BSEL	
Size : 19.7x12.5	Document Number : 40GAB1700-E110	Rev : E	
Date : Thursday, June 21, 2007		Sheet : 10 of 44	

DDR2 DIMMO

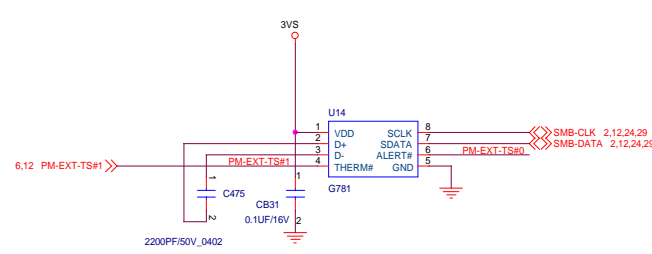
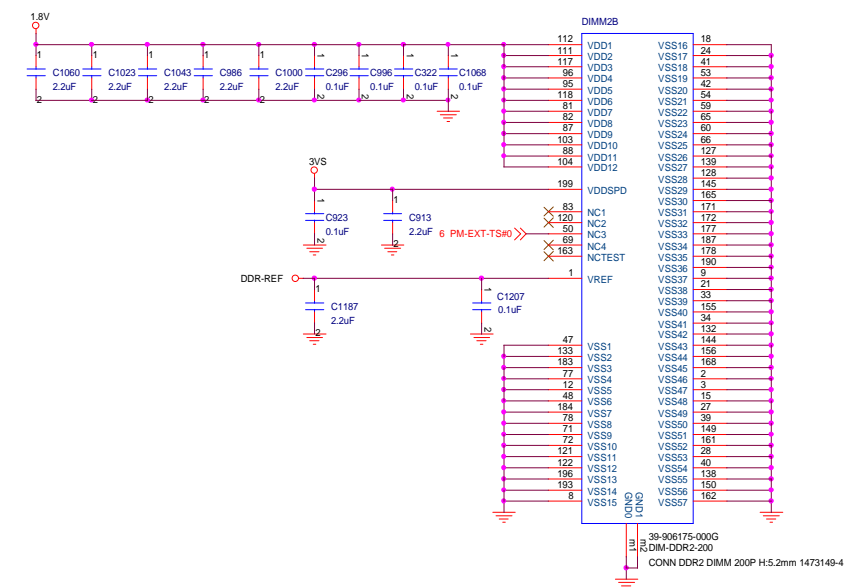
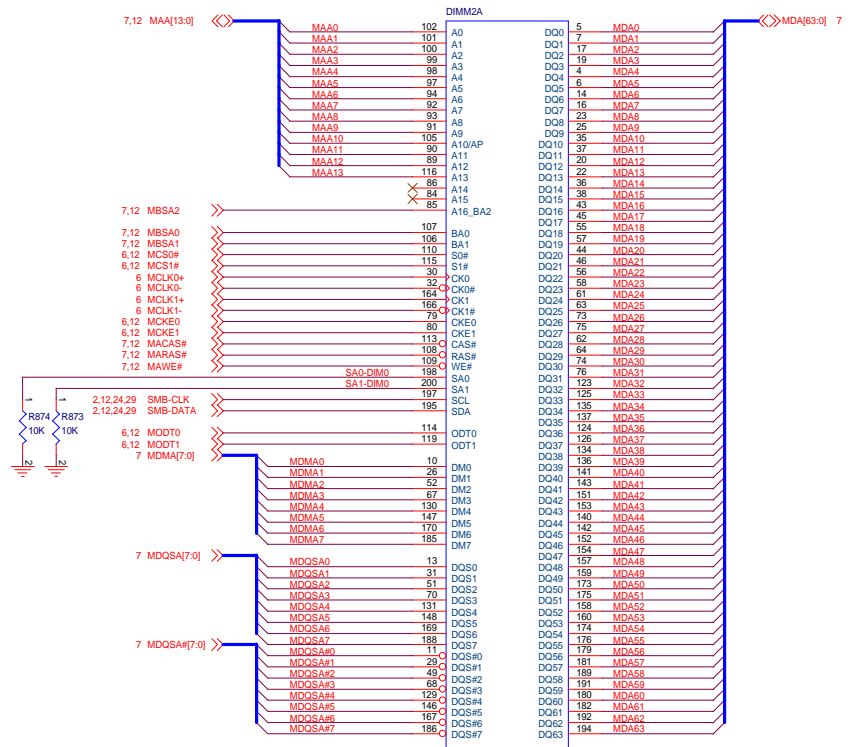

Arima		ARIMA COMPUTER CORP.	
Project Name:		Title:	
W350D1		DDR2[1/3]SODIMMO	
Size:	Document Number:	Rev:	
19.7x12.5	40GAB1700-E110	E	
Date: Thursday, June 21, 2007		Sheet: 11 of 44	

DDR2 DIMM1

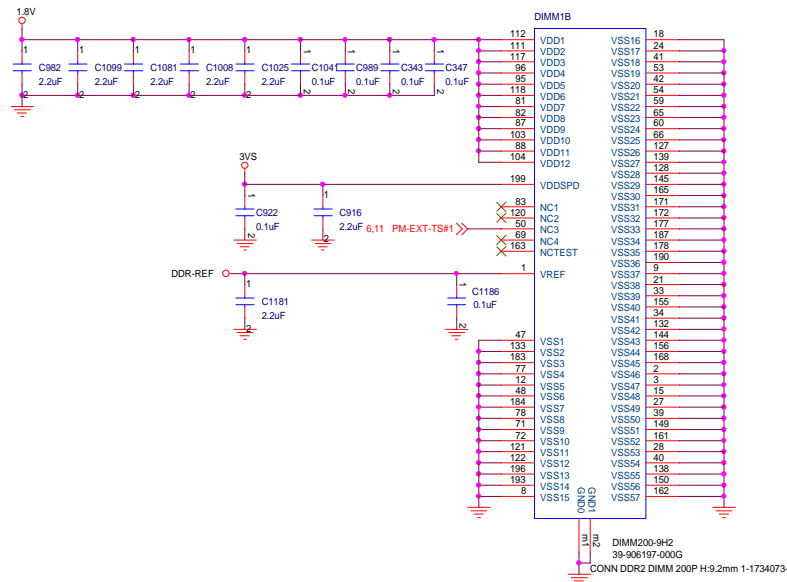
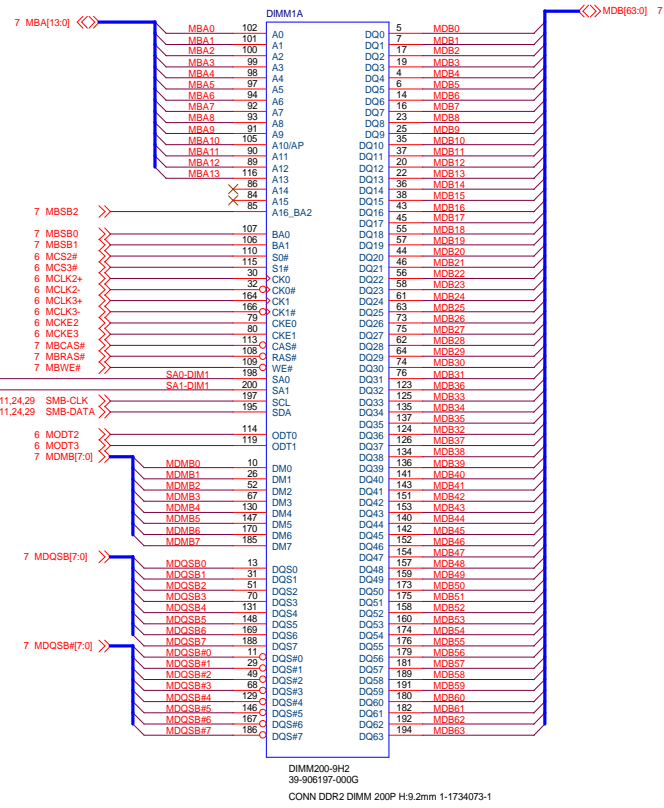

Termination

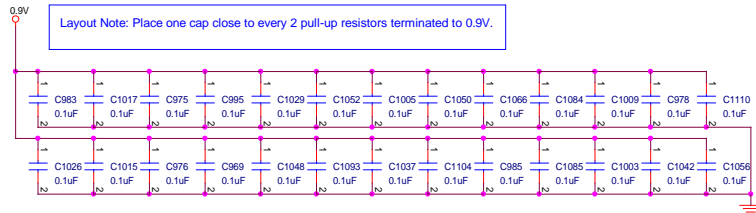
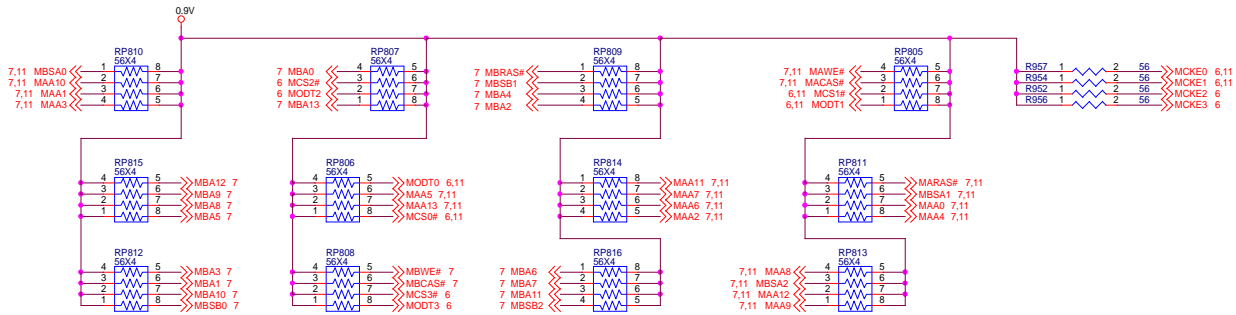

Arima
ARIMA COMPUTER CORP.

Project Name: **W350U1** Title: **DDR2[2/2]SODIMM1/Termination**

Size: **19.7x12.5** Document Number: **40GAB1700-E** Rev: **E**

Date: Thursday, June 21, 2007 Sheet: 12 of 44

VGA PCIE I/F

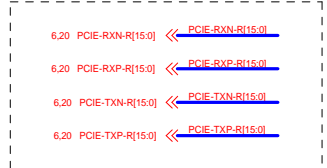
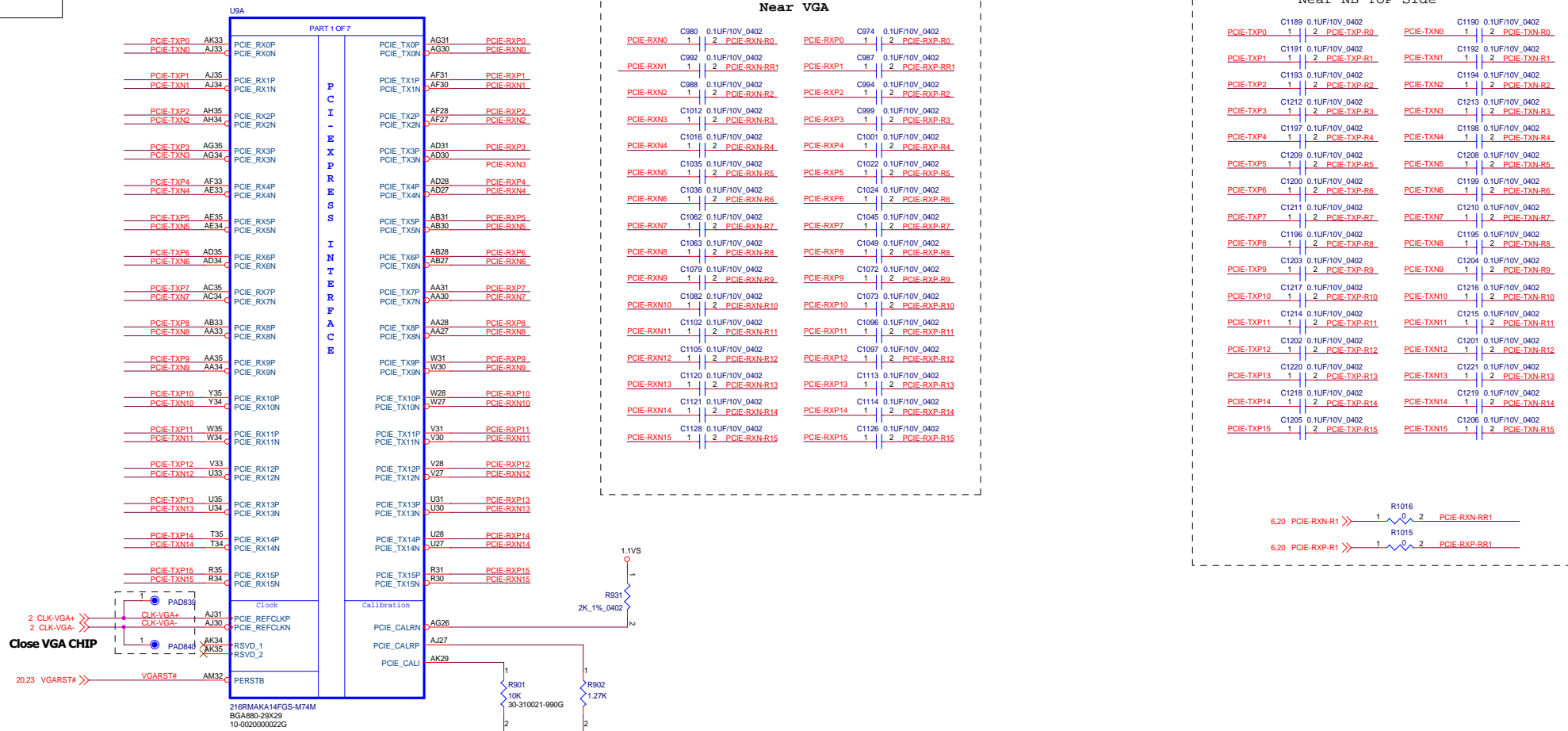

PartNumber	DESCRIPTION
10-002000022G	IC 216RMAKA14FGS M74M VGA CTRLR BGA-880
10-002000020G	IC 216RMAKA13FGS M74M VGA CTRLR BGA-880
10-002000014G	IC 216RMAKA11FG M74M VGA CTRLR BGA-880

Arima
ARIMA COMPUTER CORP.

Project Name: **W350D11** Title: **VGA-PCIE Interface /VGA Decoupling**

Size: **19.7x12.5** Document Number: **40GAB1700-E110** Rev: **E**

Date: Thursday, June 21, 2007 Sheet: 13 of 44

VGA VIDEO/MULTIMEDIA

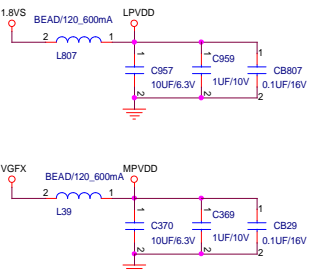
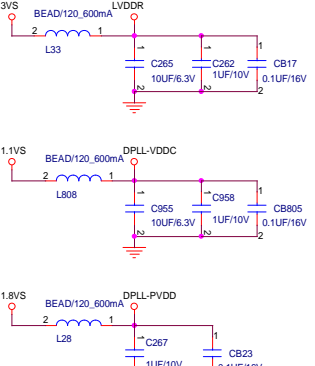
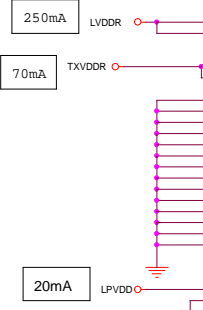

VID	Description
VID 7-0	For GPIO use.
X	
VID 3	HD audio is enabled. 1 Enable HD Audio.
EP100	Transmitter Power Saving Enable 1 - full Tx output swing
EP101	Transmitter De-emphasis Enable 0 - Tx De-Emphasis enable.
EP105	ATI internal use only 1 For PCIe PLL
EP107_BLON	Controls Backlight ON/OFF 0 External pull-down recommended
EP105_PCO	Power play control signal 0 0 Only use power play control 0
EP1016_SSN	Spread Spectrum clock input. 0 Clock Gen supply 27MHz SS
EP1017	Thermal monitor interrupt. X Connect the KBC.
EP1019	Critical temperature fault. 1 Connect to KBC.
EP1024	For normal ASIC operation. 0 Pull low 1K resistor to GND.

PartNumber	DESCRIPTION
10-002000022G	IC 216RMAKA14FGS M74M VGA CTRLR BGA-880
10-002000020G	IC 216RMAKA13FGS M74M VGA CTRLR BGA-880
10-002000014G	IC 216RMAKA11FG M74M VGA CTRLR BGA-880

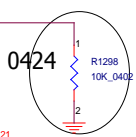

GM NA
PM MOUNT

DVPDATA22,23	Value	Description
1	1	Hynix 700MHz
1	0	RSVD
0	1	RSVD
0	0	RSVD

PM NA
R183.R196.R939

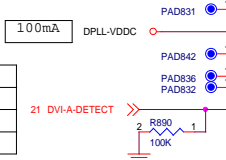
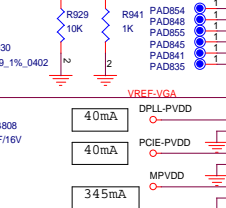
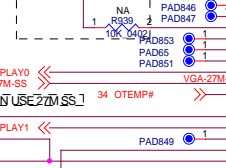
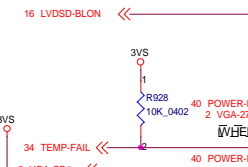

21 DV1-A-DETECT

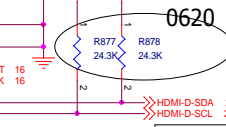
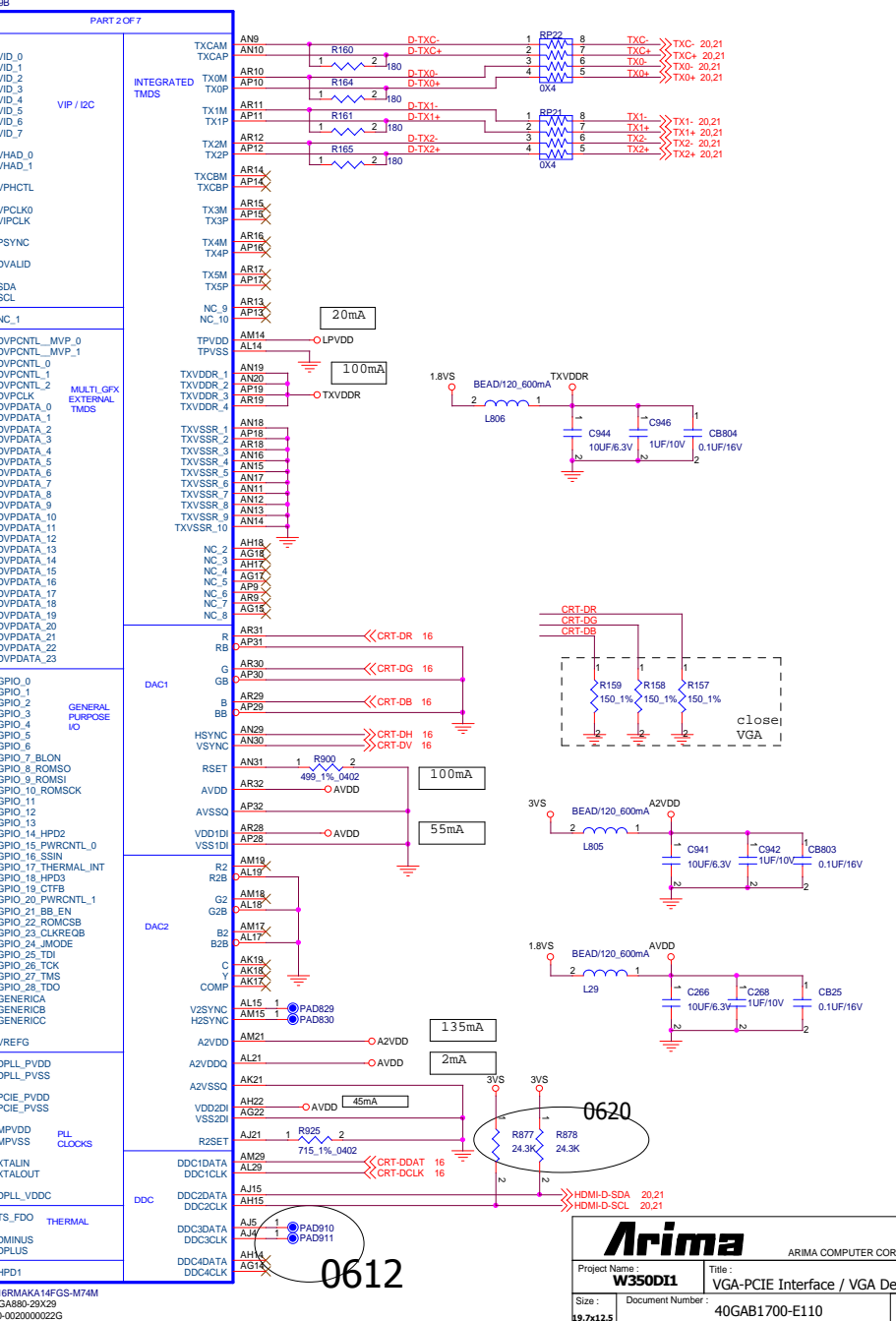
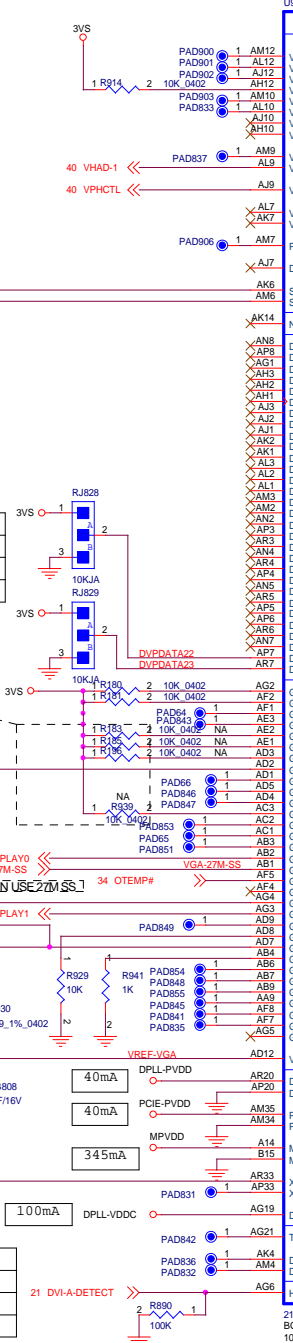

0612

Arima ARIMA COMPUTER CORP.

Project Name: **W350DI1** Title: **VGA-PCIe Interface / VGA Decoupling**

Size: **19.7x12.5** Document Number: **40GAB1700-E110** Rev: **E**

Date: **Thursday, June 21, 2007** Sheet: **14 of 44**

VGA-CorePWR

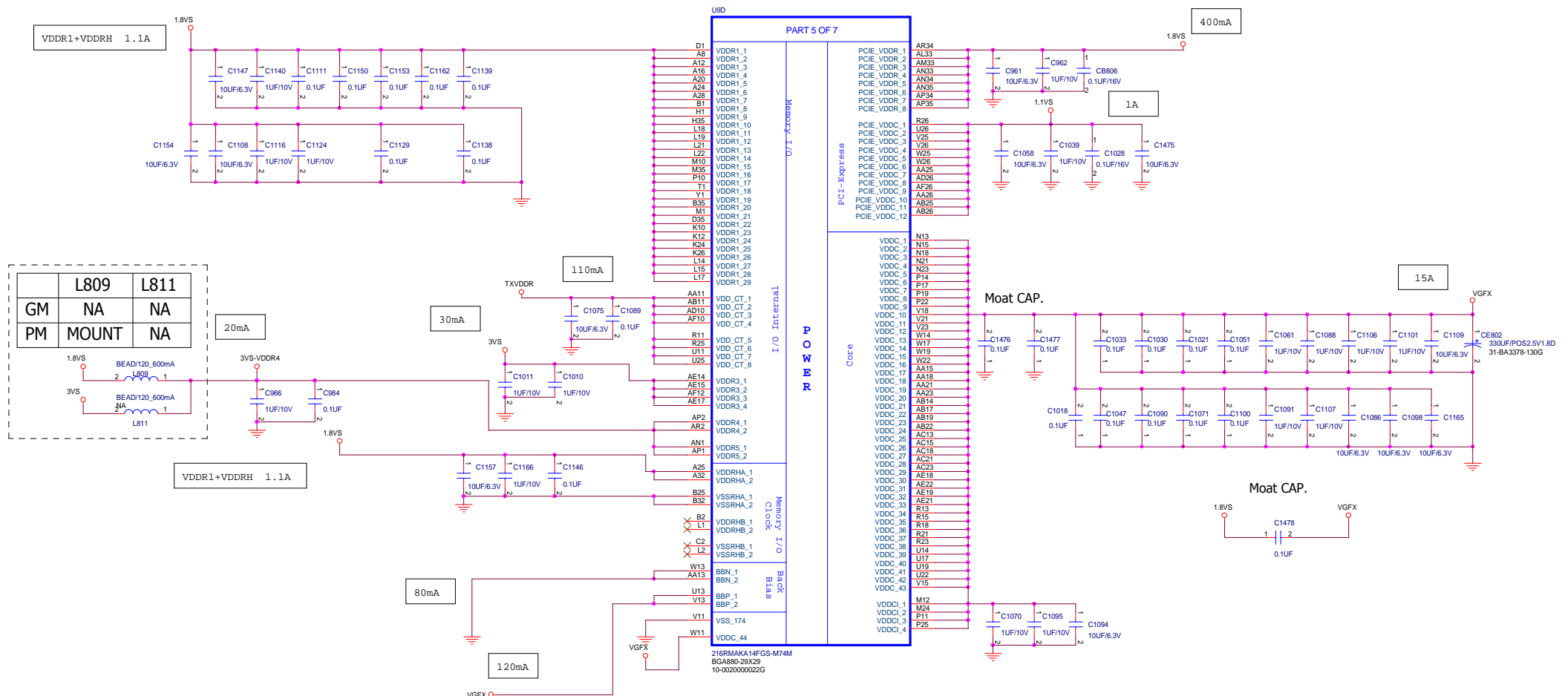

PartNumber	DESCRIPTION
10-0020000022G	IC 216RMAKA14FGS M74M VGA CTRLR BGA-880
10-0020000020G	IC 216RMAKA13FGS M74M VGA CTRLR BGA-880
10-0020000014G	IC 216RMAKA11FG M74M VGA CTRLR BGA-880

Arima
ARIMA COMPUTER CORP.

Project Name: **W350D1** Title: **VGA-CorePWR/VDDR/VDDC**

Size: **19.7x12.5** Document Number: **40GAB1700-E110** Rev: **E**

Date: Thursday, June 21, 2007 Sheet: 15 of 44

VGA JUMP

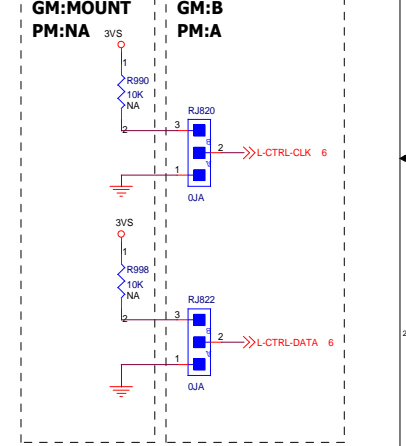
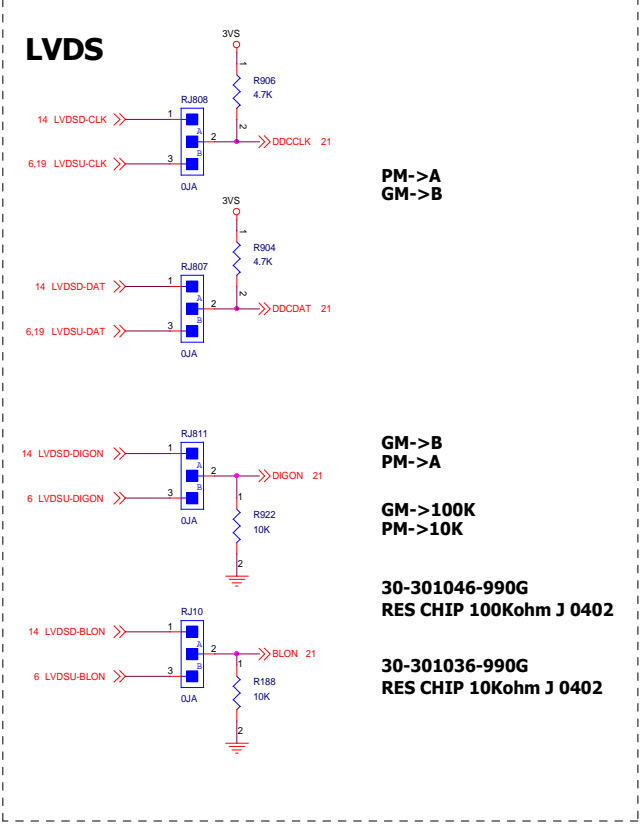
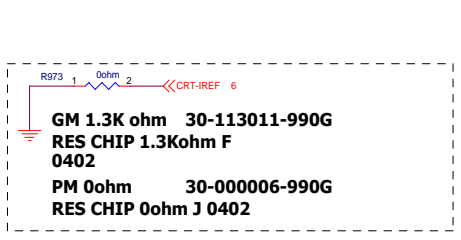
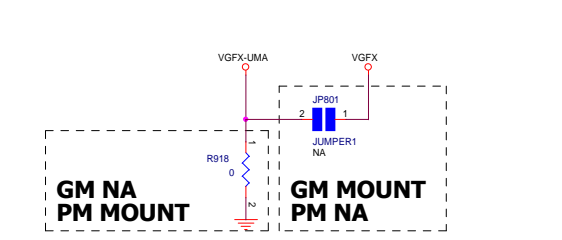
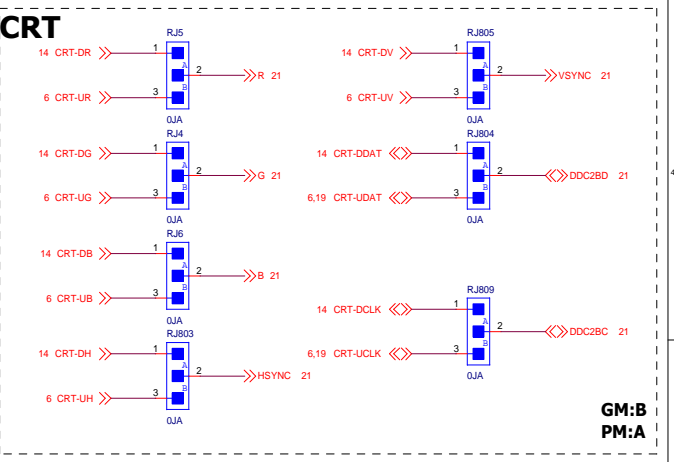
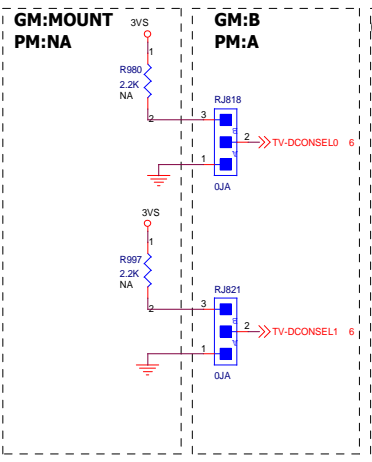
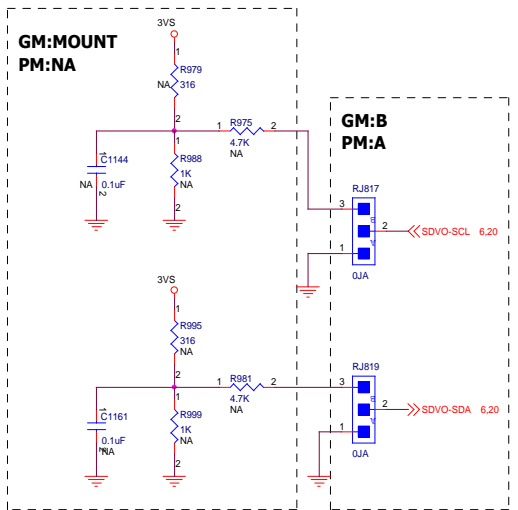
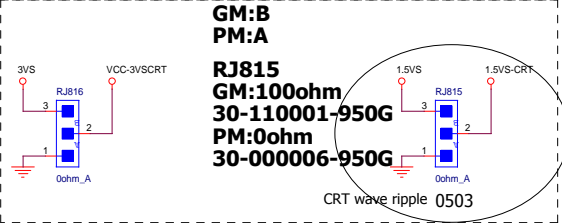
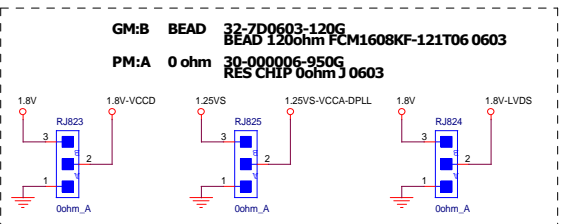

Arima		ARIMA COMPUTER CORP.	
Project Name:	W350D11	Title:	VGA-LVDS/UMA/DISCRET JUMP/GND
Size:	19.7x12.5	Document Number:	40GAB1700-E110
Date:	Thursday, June 21, 2007	Rev:	E
		Sheet:	16 of 44

VGA MEMORY & GND

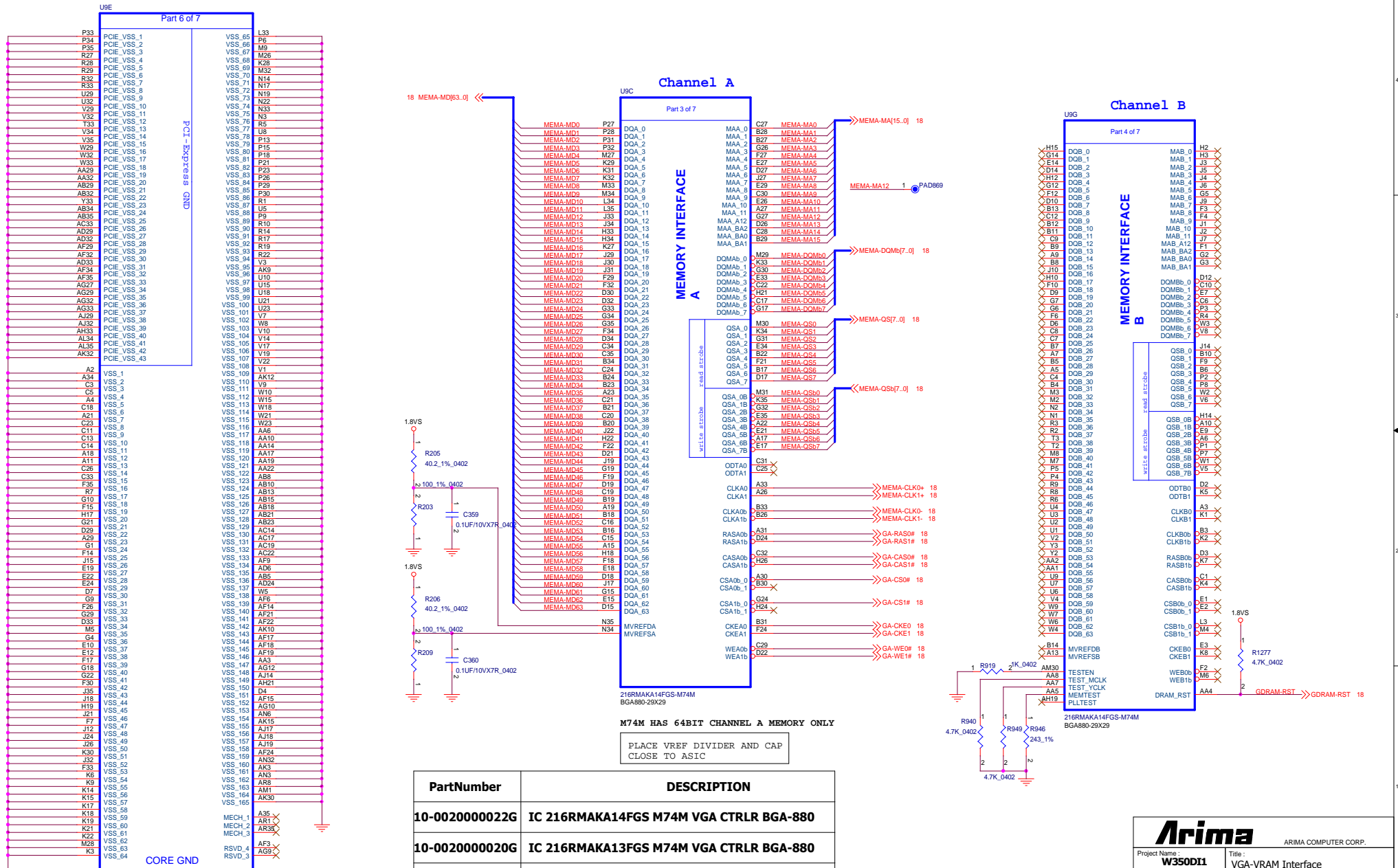

PartNumber	DESCRIPTION
10-0020000022G	IC 216RMAKA14FGS M74M VGA CTRLR BGA-880
10-0020000020G	IC 216RMAKA13FGS M74M VGA CTRLR BGA-880
10-0020000014G	IC 216RMAKA11FG M74M VGA CTRLR BGA-880

M74M HAS 64BIT CHANNEL A MEMORY ONLY
PLACE VREF DIVIDER AND CAP CLOSE TO ASIC

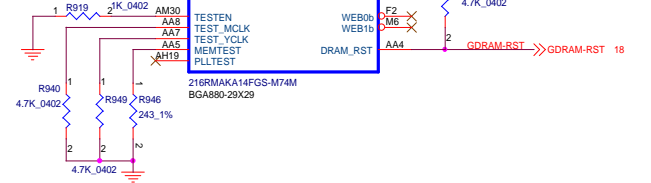

Arima ARIMA COMPUTER CORP.

Project Name: **W350D11** Title: **VGA-VRAM Interface**

Size: 19.7x12.5 Document Number: 40GAB1700-E110 Rev: E

Date: Thursday, June 21, 2007 Sheet: 17 of 44

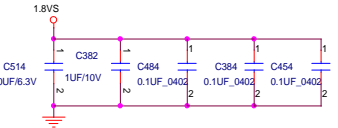
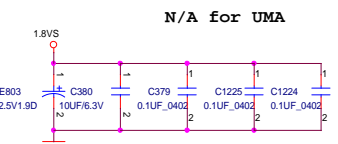
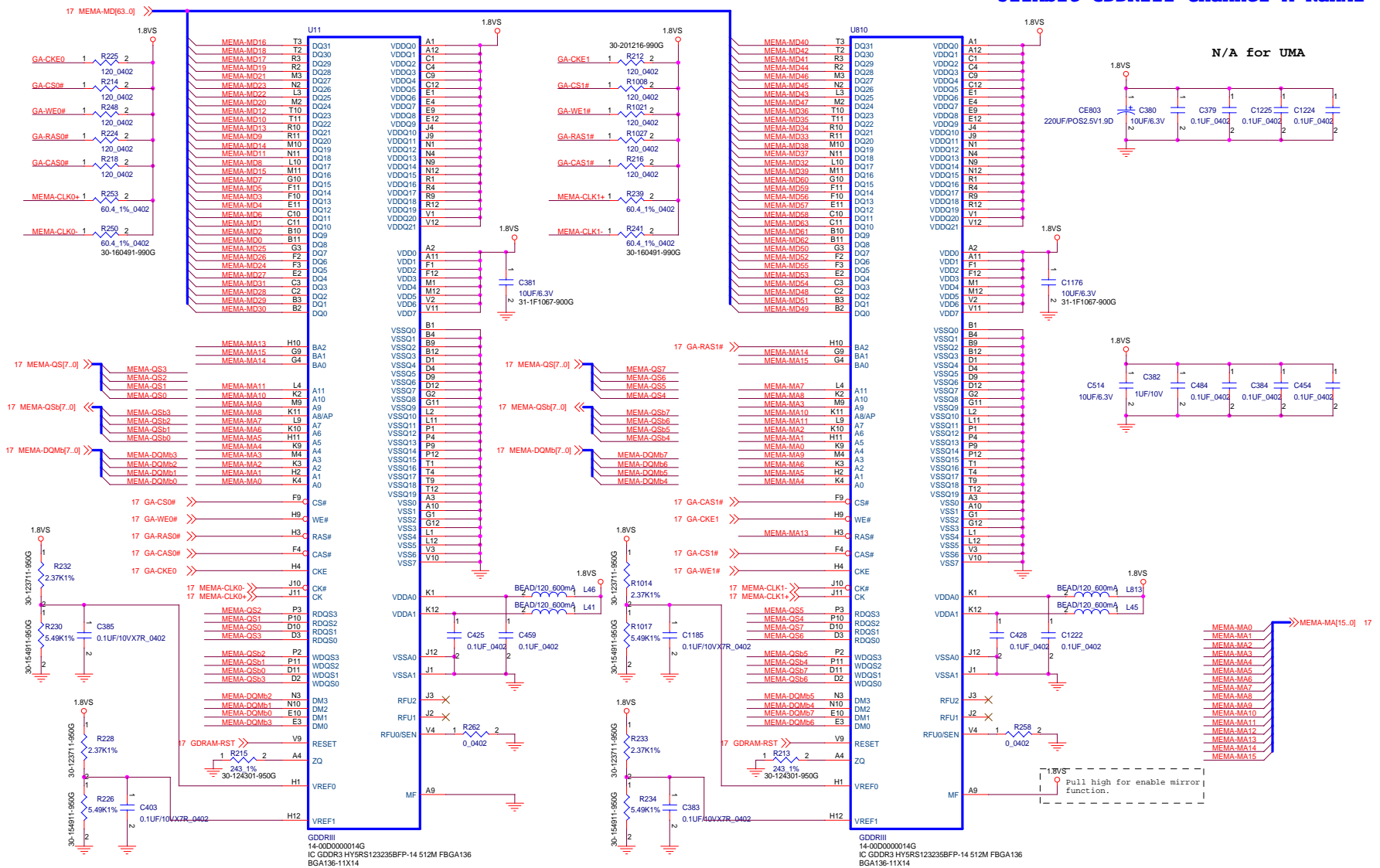

GDDRIII
14-00D0000014G
IC GDDR3 HY5RS123235BFP-14 512M FBGA136
BGA136-11X14

GDDRIII
14-00D0000014G
IC GDDR3 HY5RS123235BFP-14 512M FBGA136
BGA136-11X14

Arima		ARIMA COMPUTER CORP.	
Project Name:	W350DI	Title:	VGA-GDDR3 512Mbit BGA CH-A
Size:	19.7x12.5	Document Number:	40GAB1700-E110
Date:	Thursday, June 21, 2007	Rev:	E
		Sheet:	18 of 44

VGA GM/PM

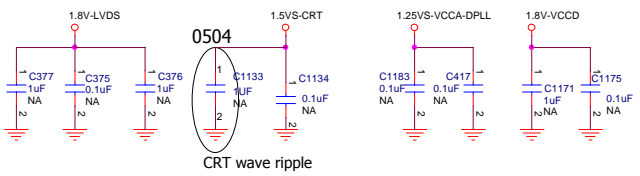
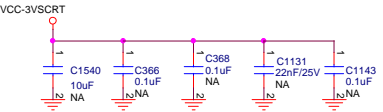
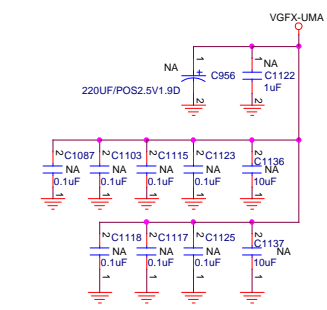
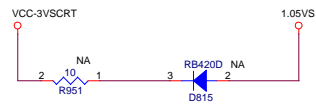

0504
CRT wave ripple

GM MOUNT PM NA

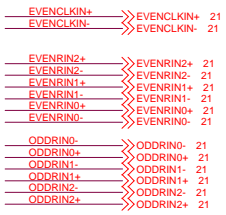
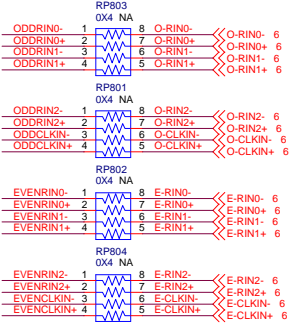

GM NA PM MOUNT

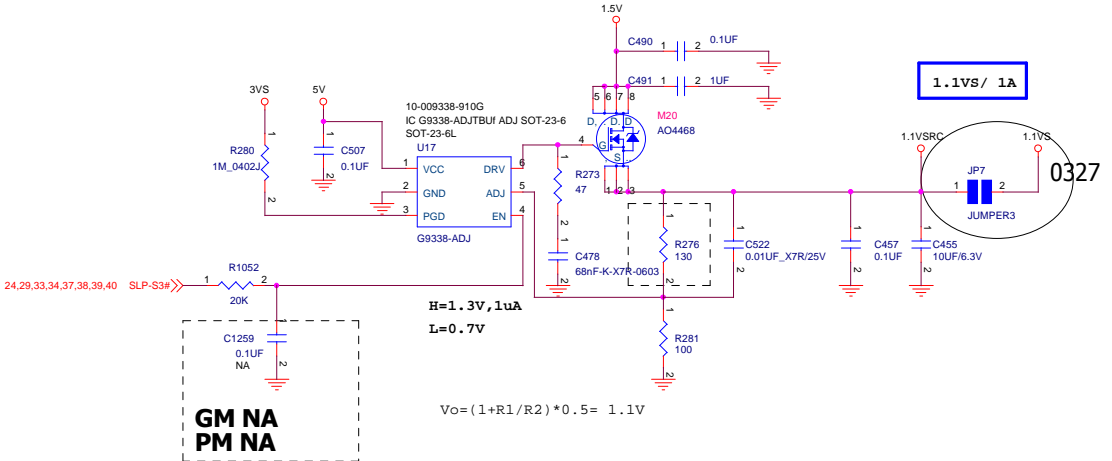
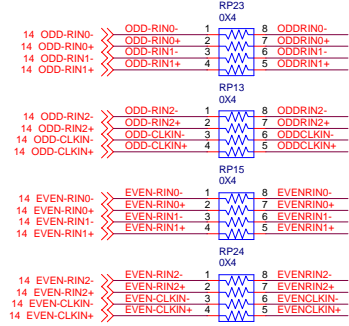

NOTE: This is for build of BOM simply. NOT EMI solution.

LAYOUT RULES:
SiI1392 TMD5 TX

Route traces with 100 Ohm Differential Impedance
Avoid placing GND Copper or traces adjacent to TMD5 Trace
Put these 4 resistors and 4 capacitors as close as possible to the TMD5 output pins of the SiI1392

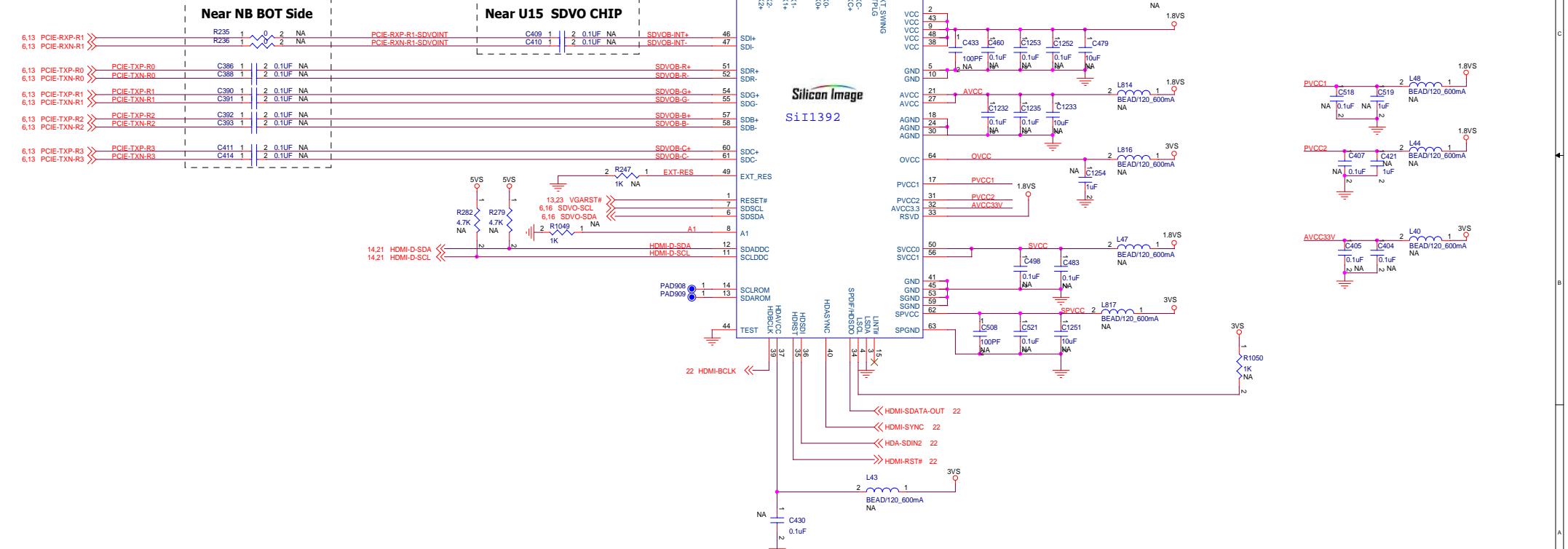

Arima		ARIMA COMPUTER CORP.	
Project Name:		Title:	
W350D11		HDMI-SII1392	
Size:	Document Number:	Rev:	
19.7x12.5	40GAB1700-E110	E	
Date:	Thursday, June 21, 2007	Sheet:	20 of 44

CRT/LVDS

VGA CONNECTOR LCD CONNECTOR INVERTER CONN.

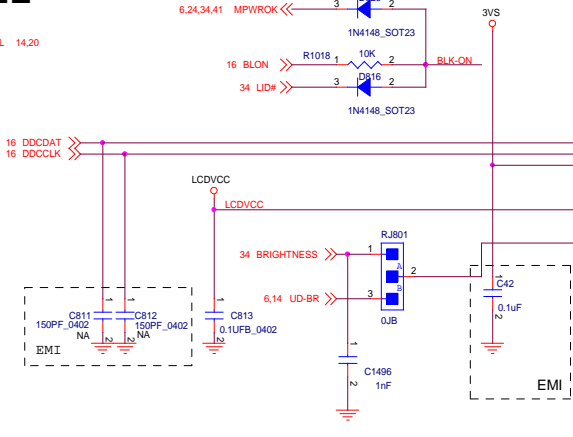
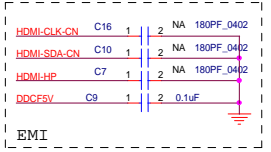
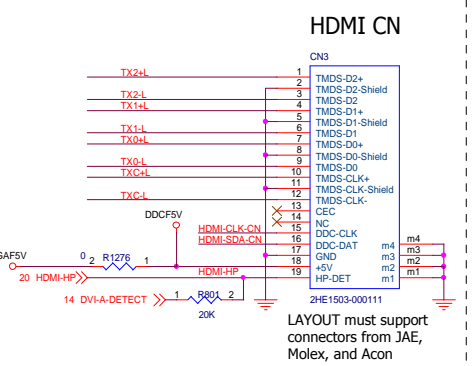
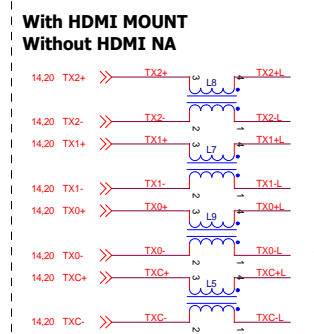
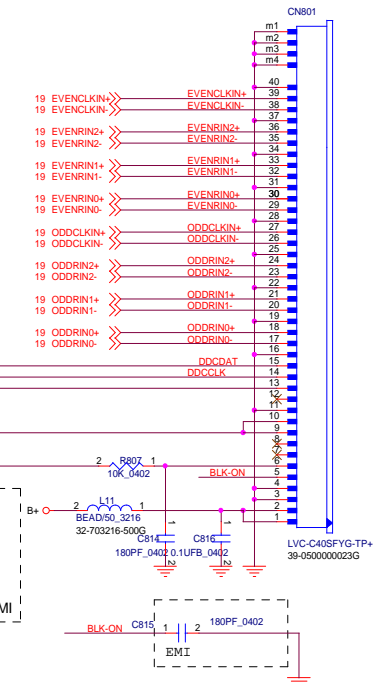
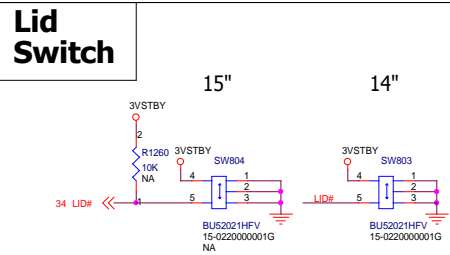
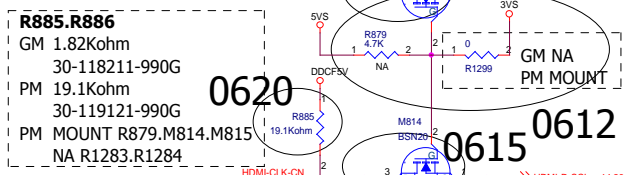
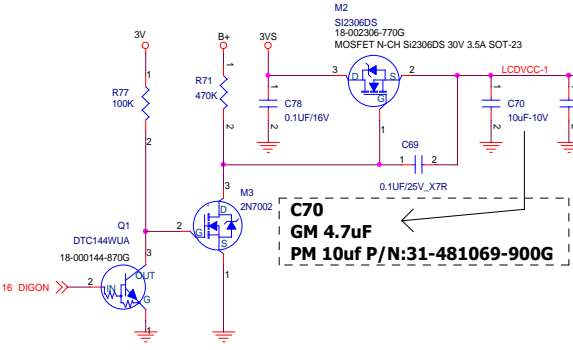
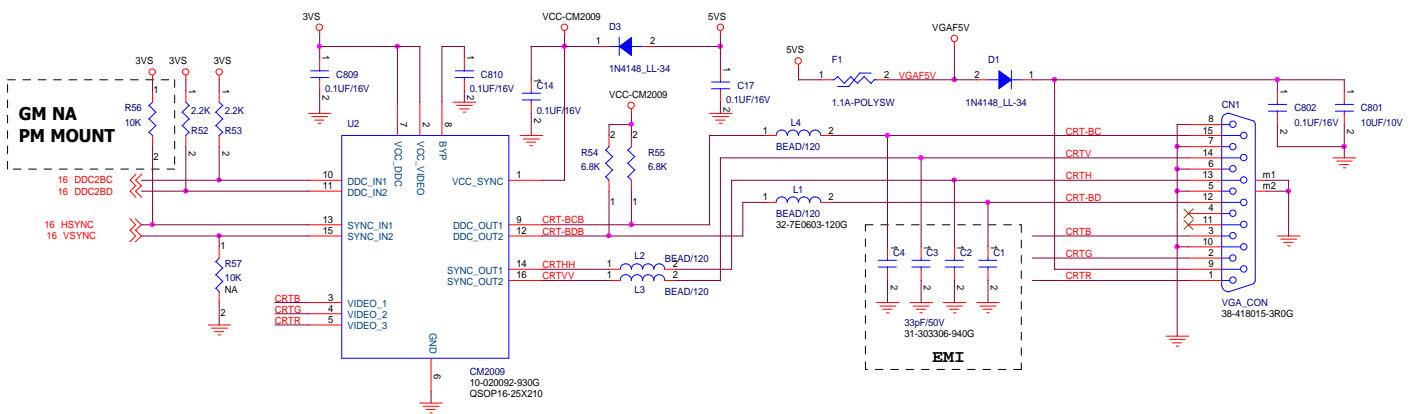
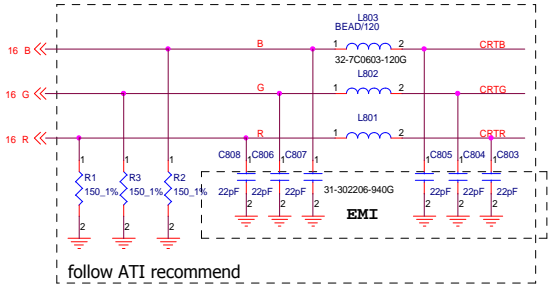

SB-RTC/IHDA/SATA/LPC/CPU/IDE

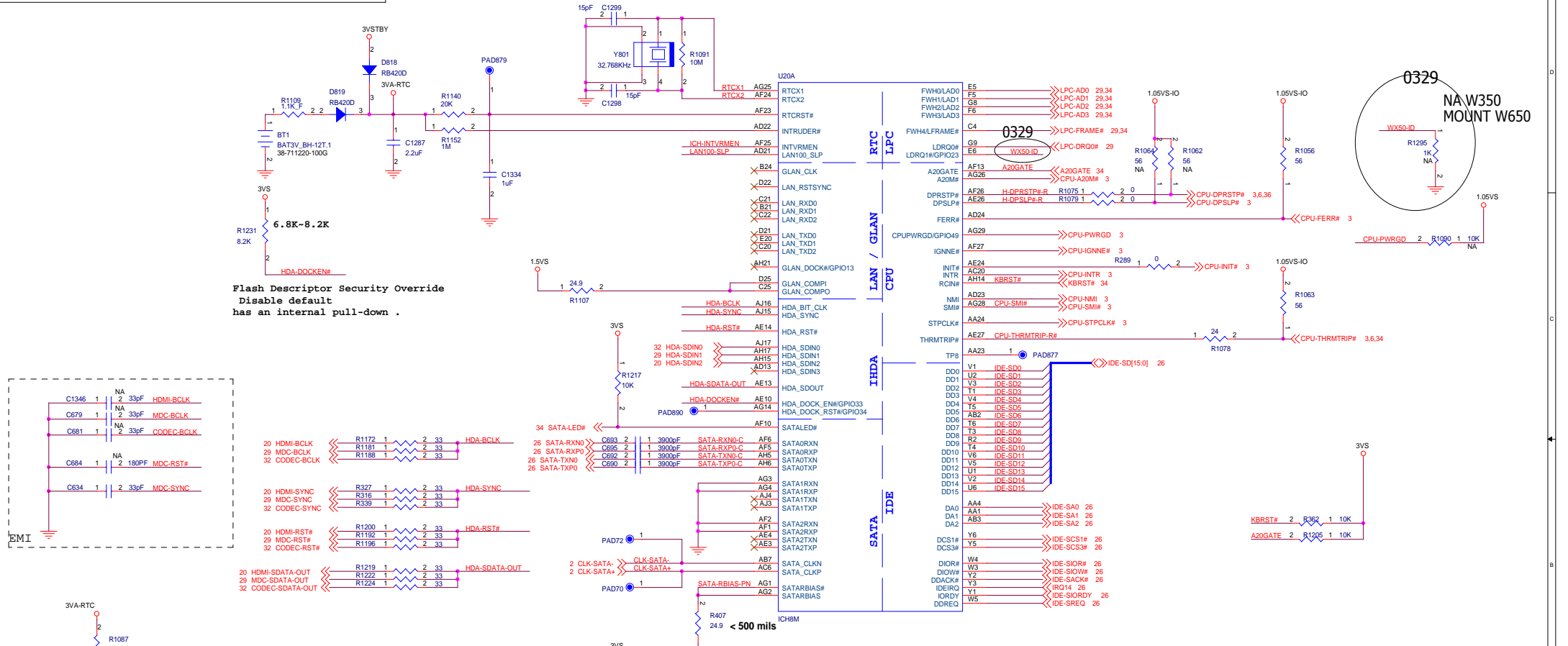

Flash Descriptor Security Override
 Disable default
 has an internal pull-down .

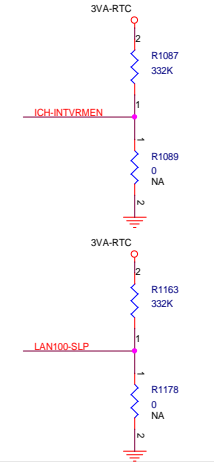
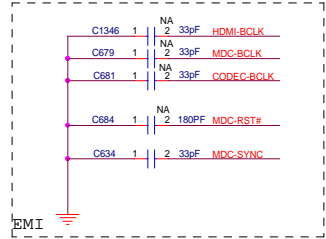

XOR Chain Entrance Strap		
ICH RSVD	HDA SDOOUT	Description
0	0	RSVD
0	1	Enter XOR Chain
1	0	Normal Operation (Default)
1	1	Set PCIE port config bit 1

ICH8-M Internal VR Enable Strap
 (Internal VR for VccSus1_05, VccSus1_5 and VccCL1_5)

ICH-INTVRMEN	Low = Internal VR Disabled High = Internal VR Enabled (Default)
--------------	--

ICH8-M LAN100_SLP Strap
 (Internal VR for VccLAN1_05 and VccCL1_05)

LAN100_SLP	Low = Internal VR Disabled High = Internal VR Enabled (Default)
------------	--

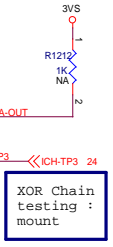

PartNumber	DESCRIPTION
10-0010000026G	IC ICH8M QN23 QS SOUTHBRIDGE BGA-676
10-0010000031G	IC ICH8M SLA5Q SOUTHBRIDGE BGA-676 INTEL

ARIMA COMPUTER CORP.

Project Name: W350DI		Title: SB-RTC/IHDA/SATA/LPC/CPU/IDE	
Size: 19.7x12.5	Document Number: 40GAB1700-E110	Rev: E	
Date: Thursday, June 21, 2007		Sheet: 22 of 44	

SB-PCIE/SPI/DMI/USB/PCI/INT

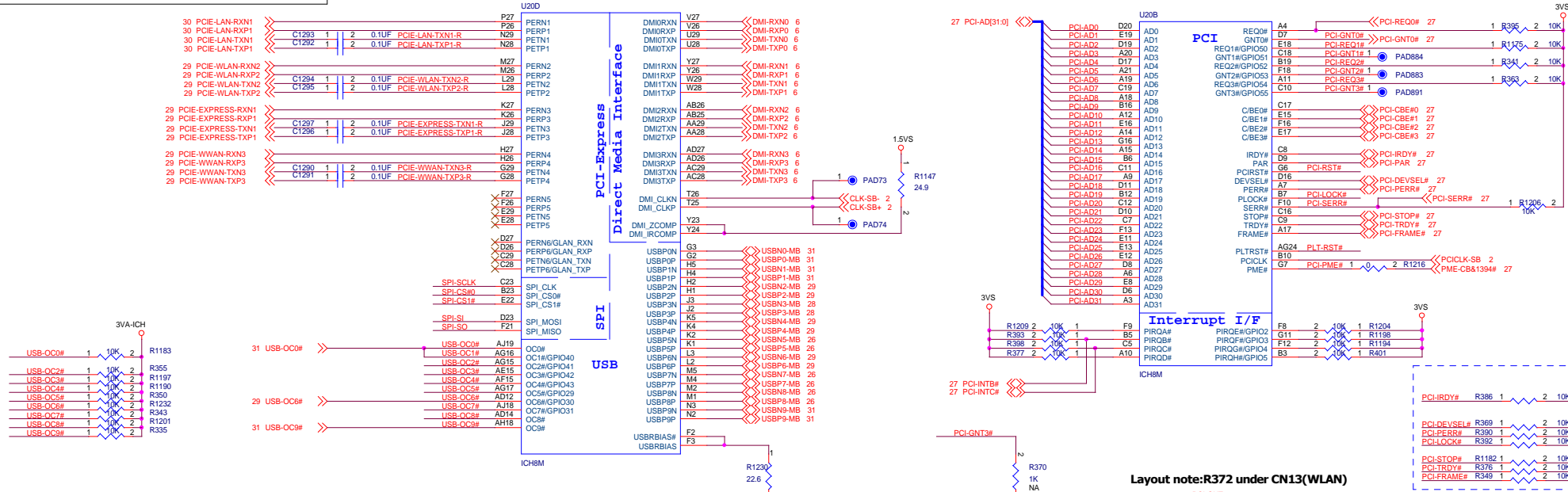

PartNumber	DESCRIPTION
10-0010000026G	IC ICH8M QN23 QS SOUTHBRIDGE BGA-676
10-0010000031G	IC ICH8M SLA5Q SOUTHBRIDGE BGA-676 INTEL

A16 swap voerride strap	
PCI-GNT3#	Low = A16 swap override enabled High = Default

PCI-GNT0#	SPI-CS1#	Boot BIOS Location
0	1	SPI
1	0	PCI
1	1	LPC (Default)

Reset Signals

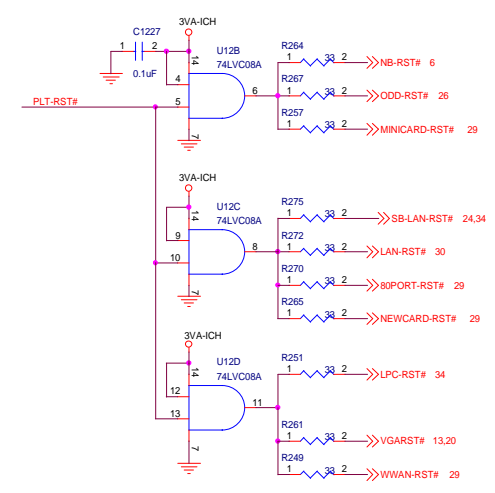

FOR PCIRST#

SPI Flash ROM

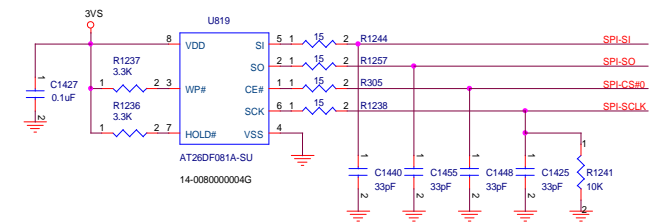

Arima ARMA COMPUTER CORP.

Project Name: **w3500i** Title: SB-PCIE/SPI/DMI/USB/PCI/INT

Size: 19.7x12.5 Document Number: 40GAB1700-E110 Rev: E

Date: Thursday, June 21, 2007 Sheet: 23 of 44

SB-SMBUS/GPIO/MISC/PWM/CL

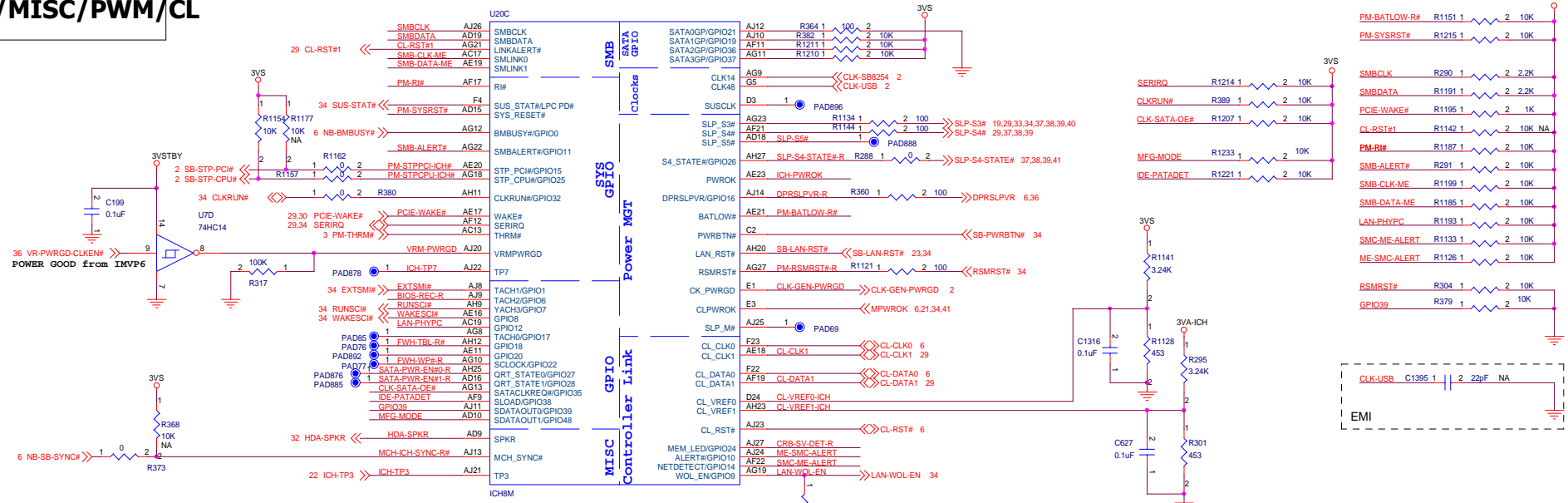

PartNumber	DESCRIPTION
10-0010000026G	IC ICH8M QN23 QS SOUTHBRIDGE BGA-676
10-0010000031G	IC ICH8M SLA5Q SOUTHBRIDGE BGA-676 INTEL

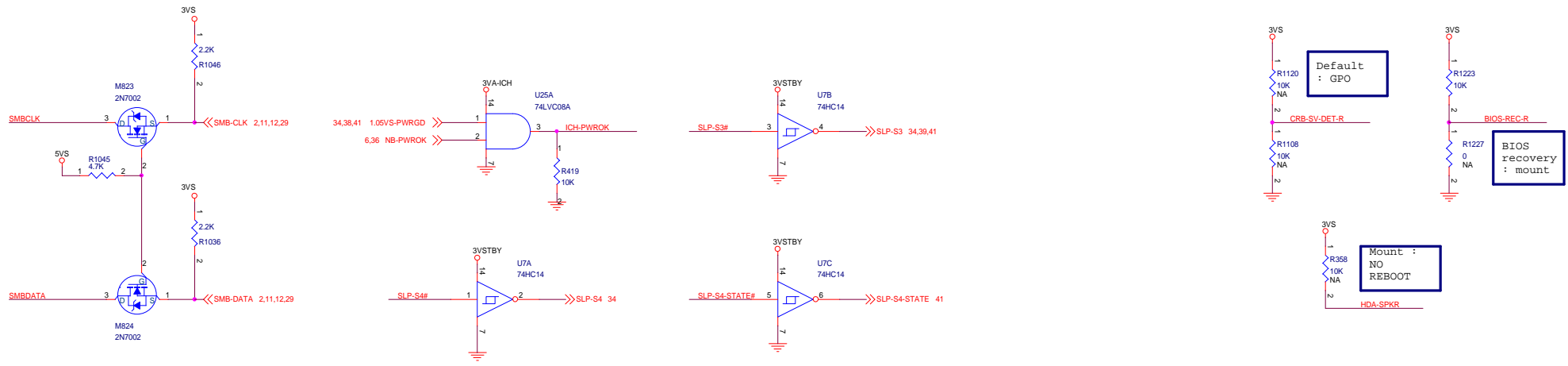

Arima ARIMA COMPUTER CORP.

Project Name: **w350DI** Title: **SB-SMBUS/GPIO/MISC/PWM/CL**

Size: **19.7x12.5** Document Number: **40GAB1700-E110** Rev: **E**

Date: Thursday, June 21, 2007 Sheet: 24 of 44

SB PWR/GND

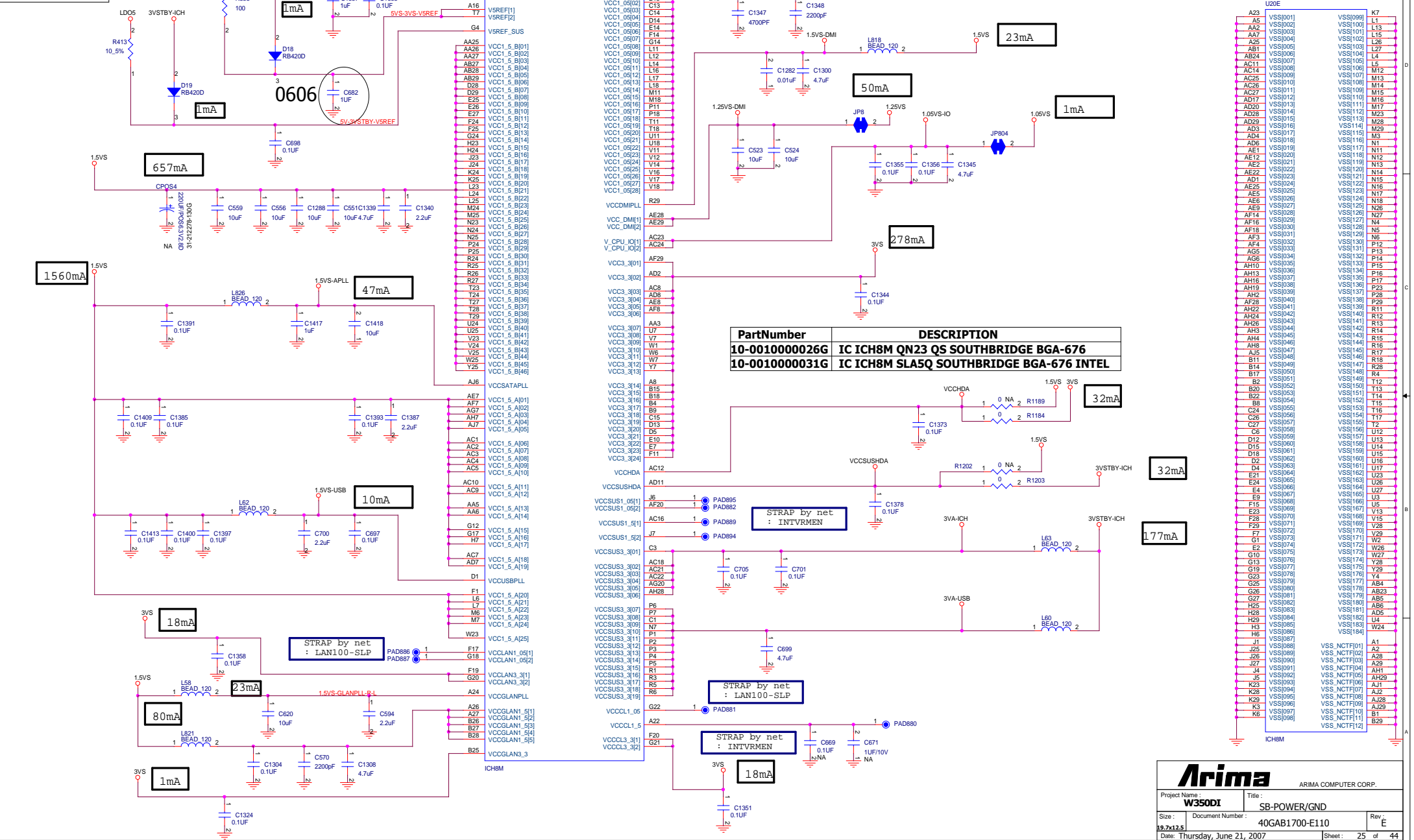

ARIMA COMPUTER CORP.

Project Name:	W350DI	Title:	SB-POWER/GND
Size:	19.7x12.5	Document Number:	40GAB1700-E110
Date:	Thursday, June 21, 2007	Sheet:	25 of 44

ODD

NA	14" CN13 · C1174 · C1172	15" CN12 · C1173
Mount	CN12 · C1173	CN13 · C1174 · C1172

14"

15"

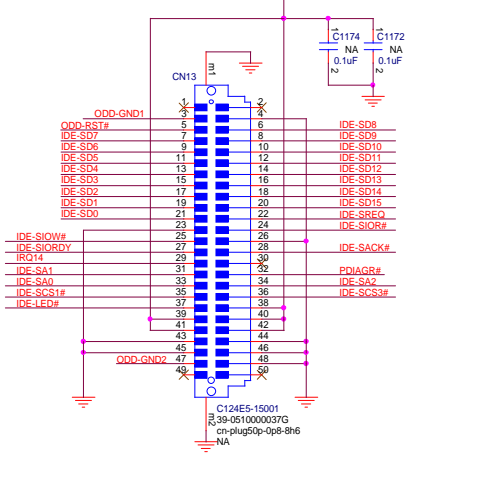
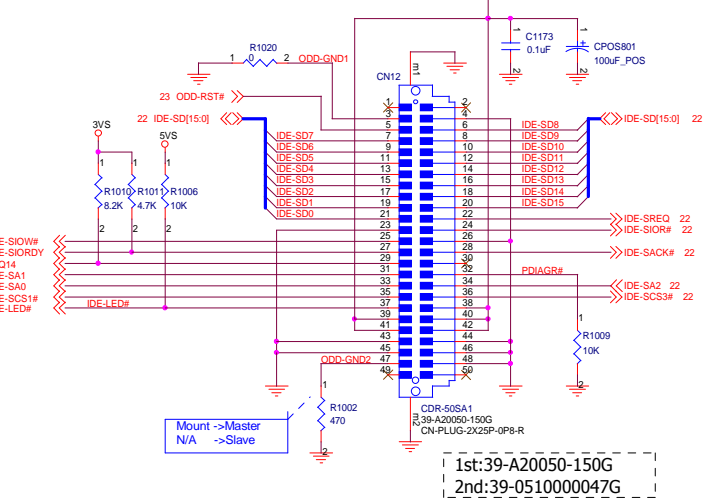

1st:39-A20050-150G
2nd:39-0510000047G

HDD

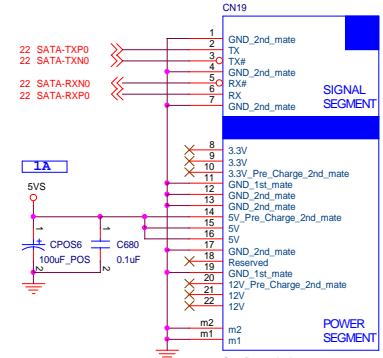

Volum board

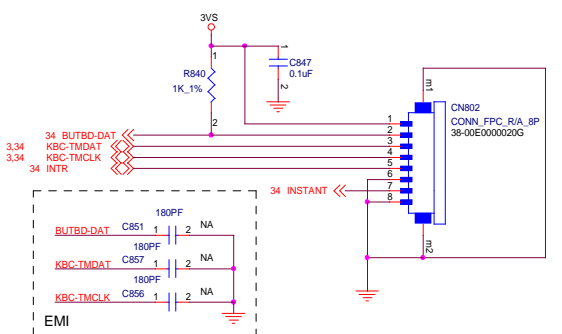

Bluetooth

WebCAM

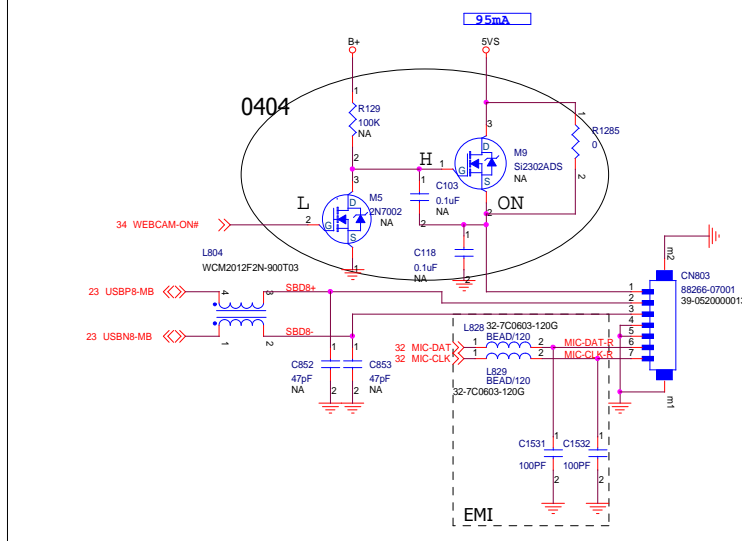
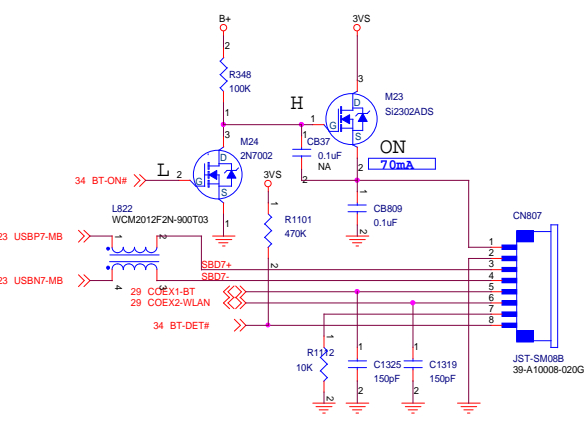

FPR CN

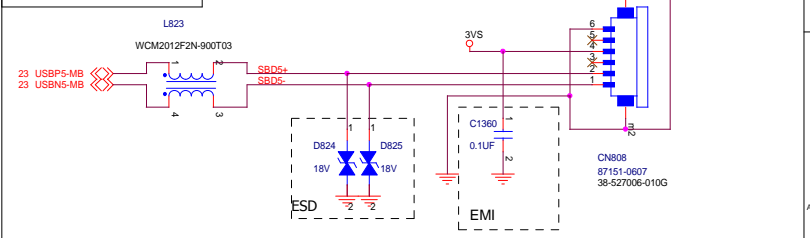

Arima ARIMA COMPUTER CORP.

Project Name: **w350DI** Title: **ODD/HD/BlueTH/WebCam/FingerPRINT**

Size: **19.7x12.5** Document Number: **40GAB1700-E110** Rev: **E**

Date: **Thursday, June 21, 2007** Sheet: **26 of 44**

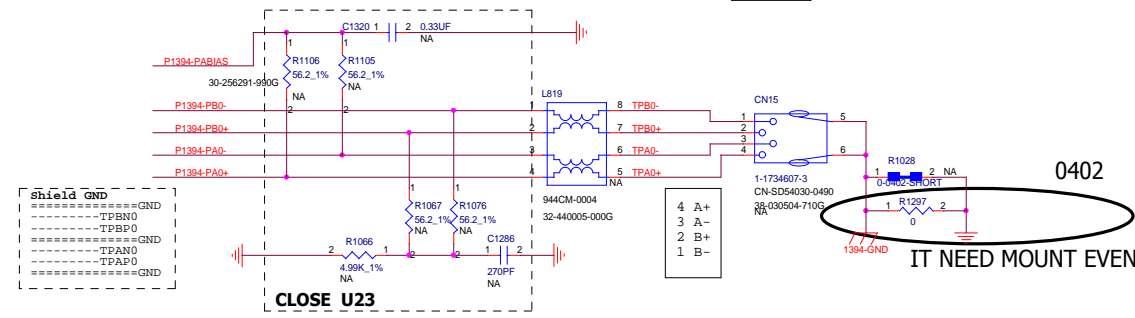
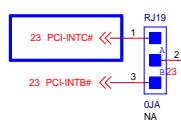
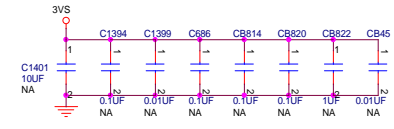
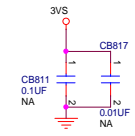
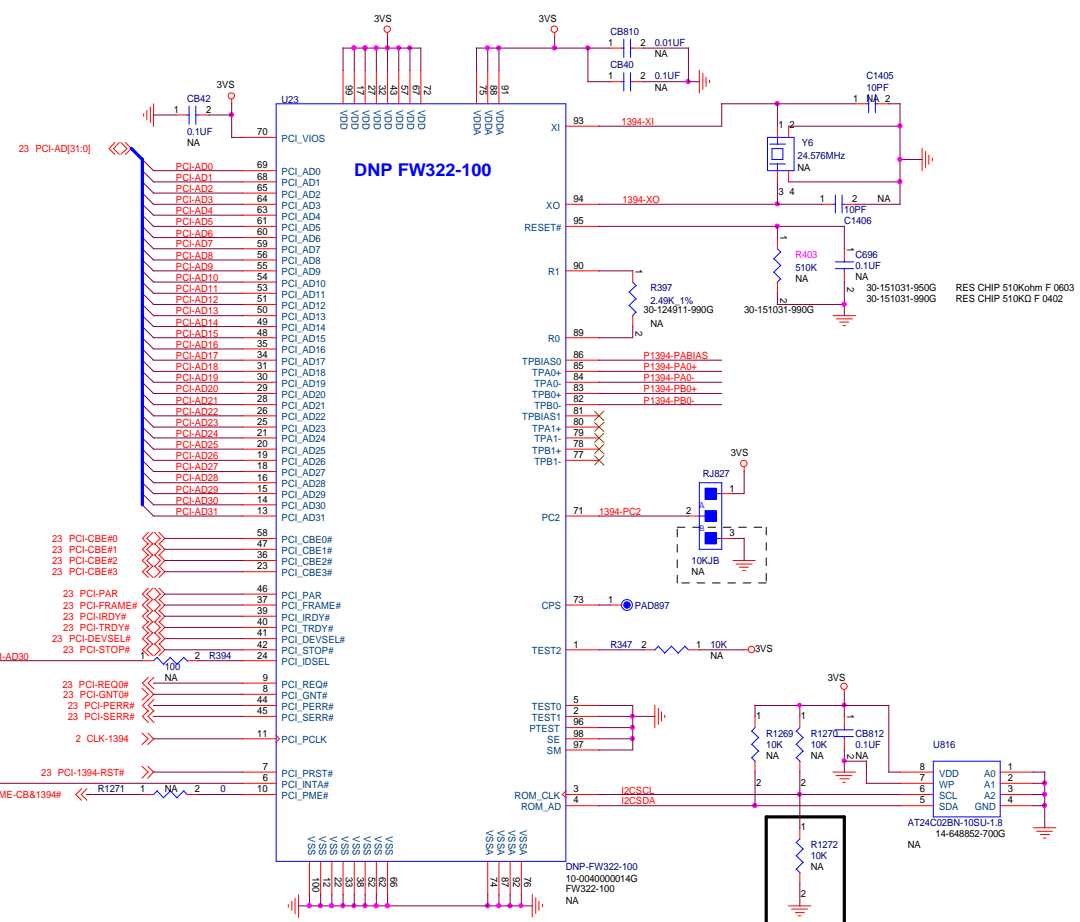

Arima		ARIMA COMPUTER CORP.	
Project Name :	W350D1	Title :	1394a-DNP-FW322-100
Size :	Document Number :	40GAB1700-E110	Rev : E
19.7x12.5	Date : Thursday, June 21, 2007	Sheet :	27 of 44

RTS5158_CardReader

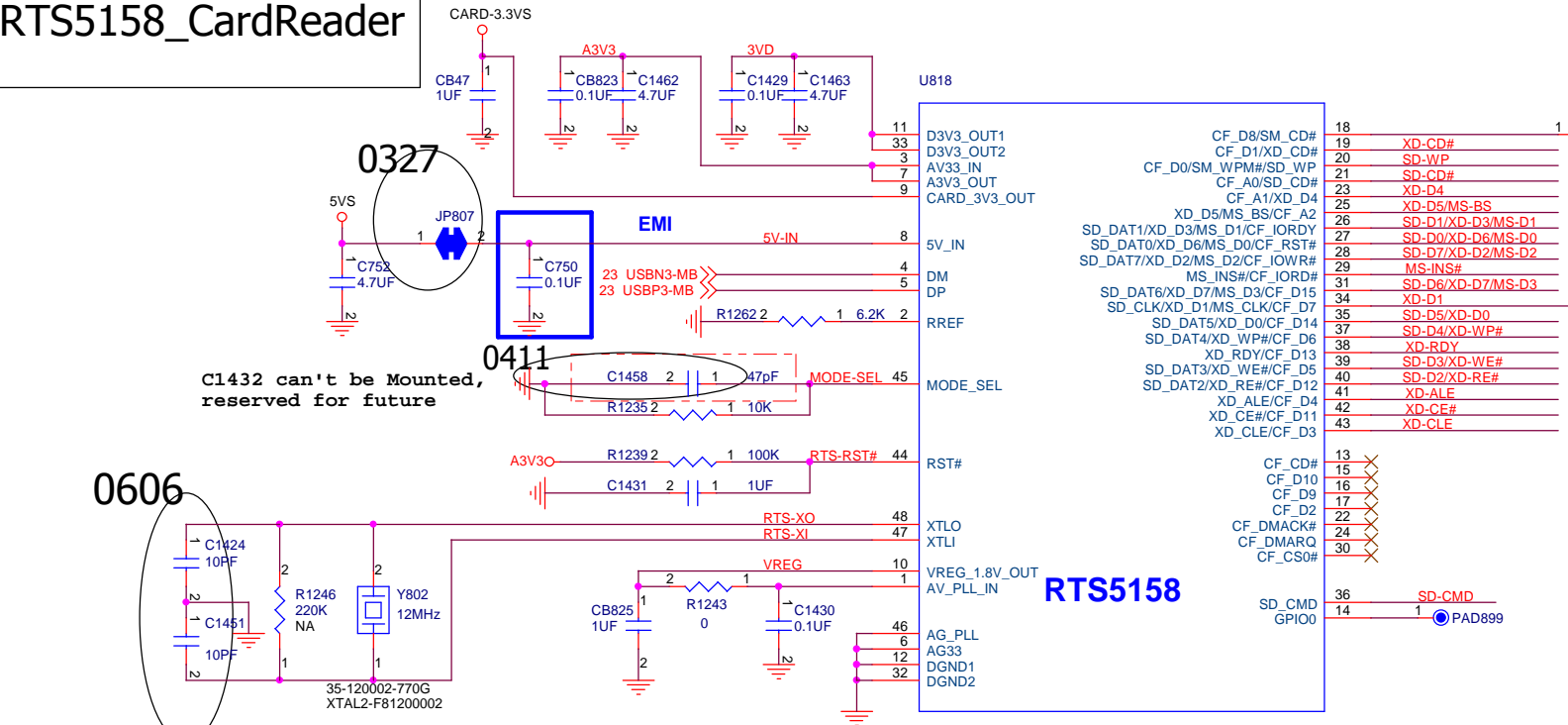

C1432 can't be Mounted, reserved for future

change connector after PCB Rev.E

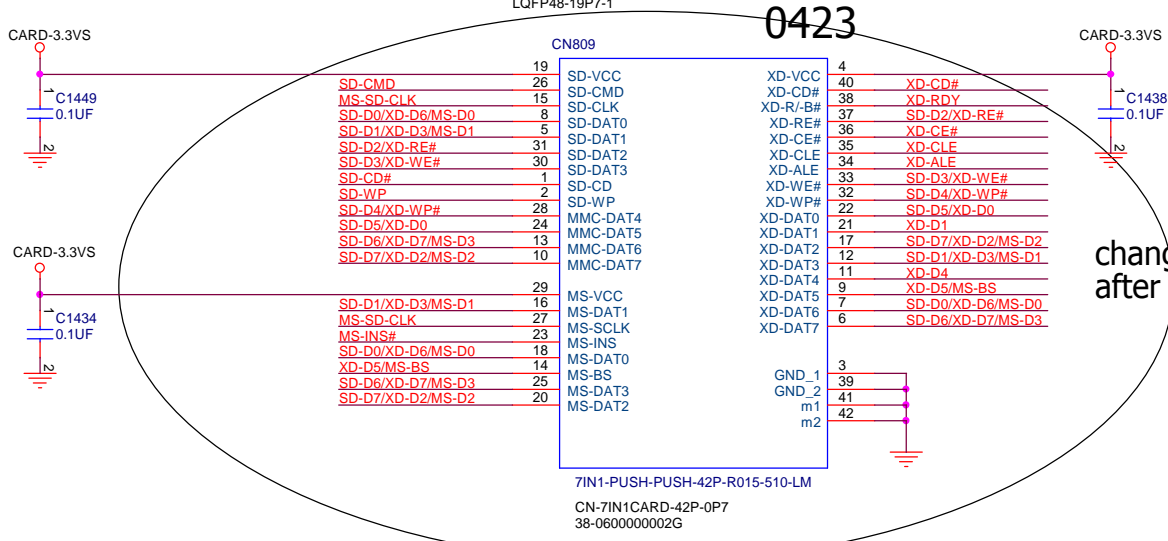

Arima ARIMA COMPUTER CORP.

Project Name: **W350DI1** Title: **RTS5158 5 IN 1 CARDreader**

Size: **14x9** Document Number: **40GAB1700-E110** Rev: **E**

Date: **Thursday, June 21, 2007** Sheet: **28** of **44**

New Card

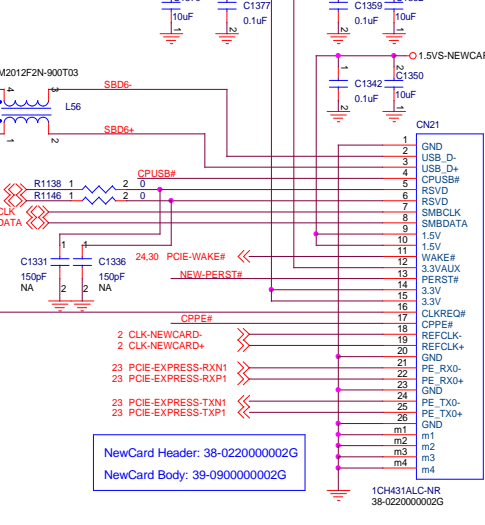
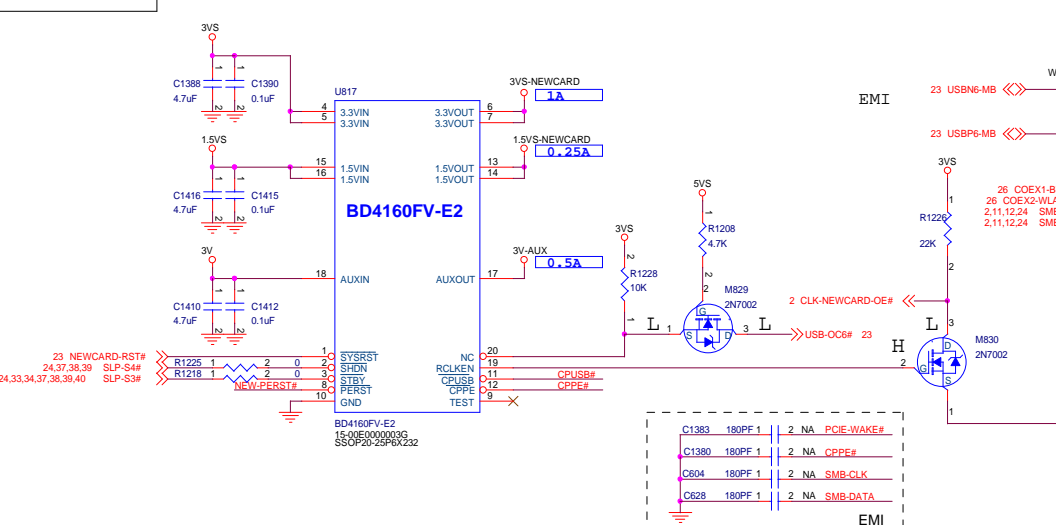

MDC

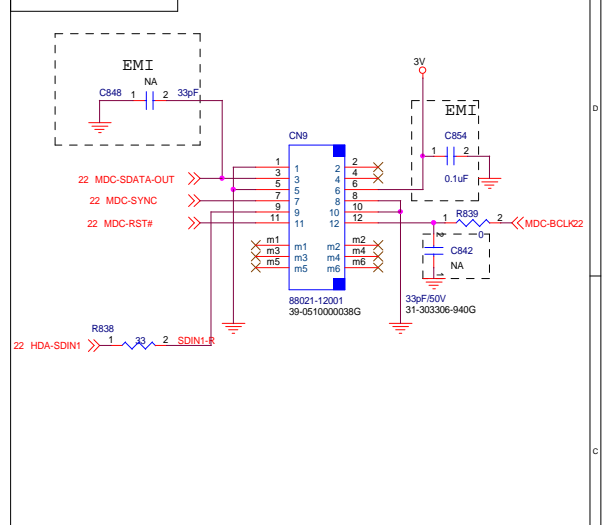

WWAN

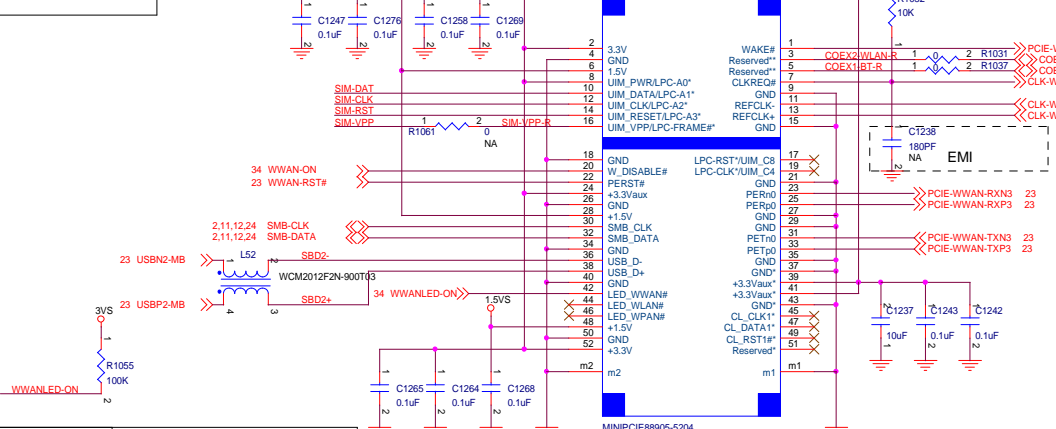

SIM CN

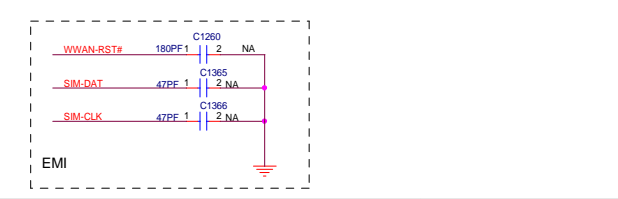
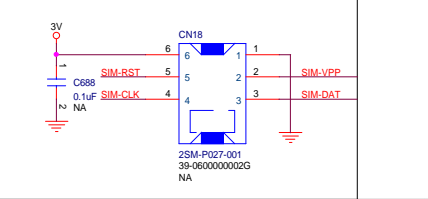

WLAN

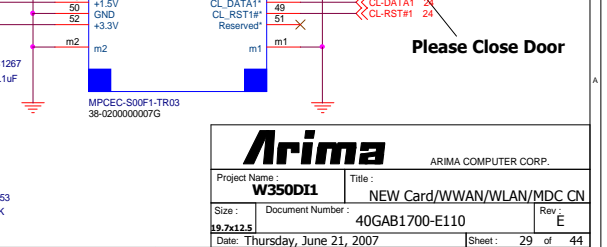
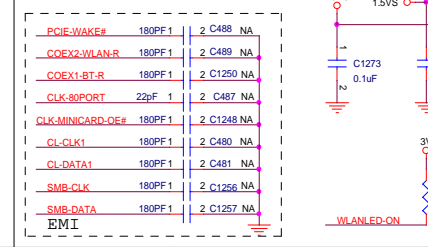
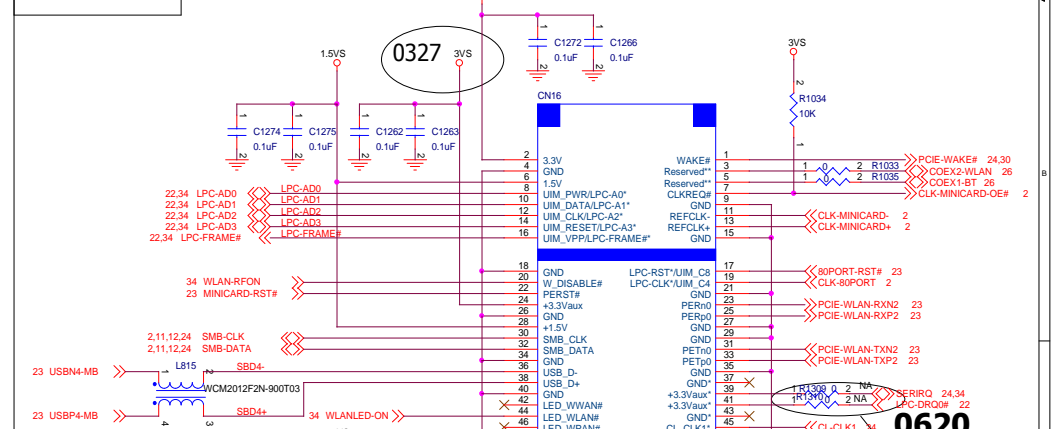

Arima ARIMA COMPUTER CORP.

Project Name: **W350D11** Title: **NEW Card/WWAN/WLAN/MDC CN**

Size: **19.7x12.5** Document Number: **40GAB1700-E110** Rev: **E**

Date: **Thursday, June 21, 2007** Sheet: **29 of 44**

LAN

LAN_VDD33
SPEC=668mA(103+367+198)

LAN POWER

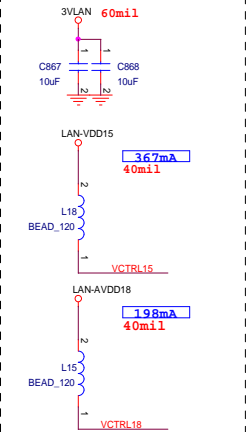

R505 should be 2.0K Ω for 8101E application!

C670, C674, C677
廠商建議使用22uF
2006.09.26

GVDD is internal 1.5V, can not be the 1.5V SRC for other 1.5V demand. 2005/8/2 confirmed FAN Patrick

CLOSE TO CHIPSET

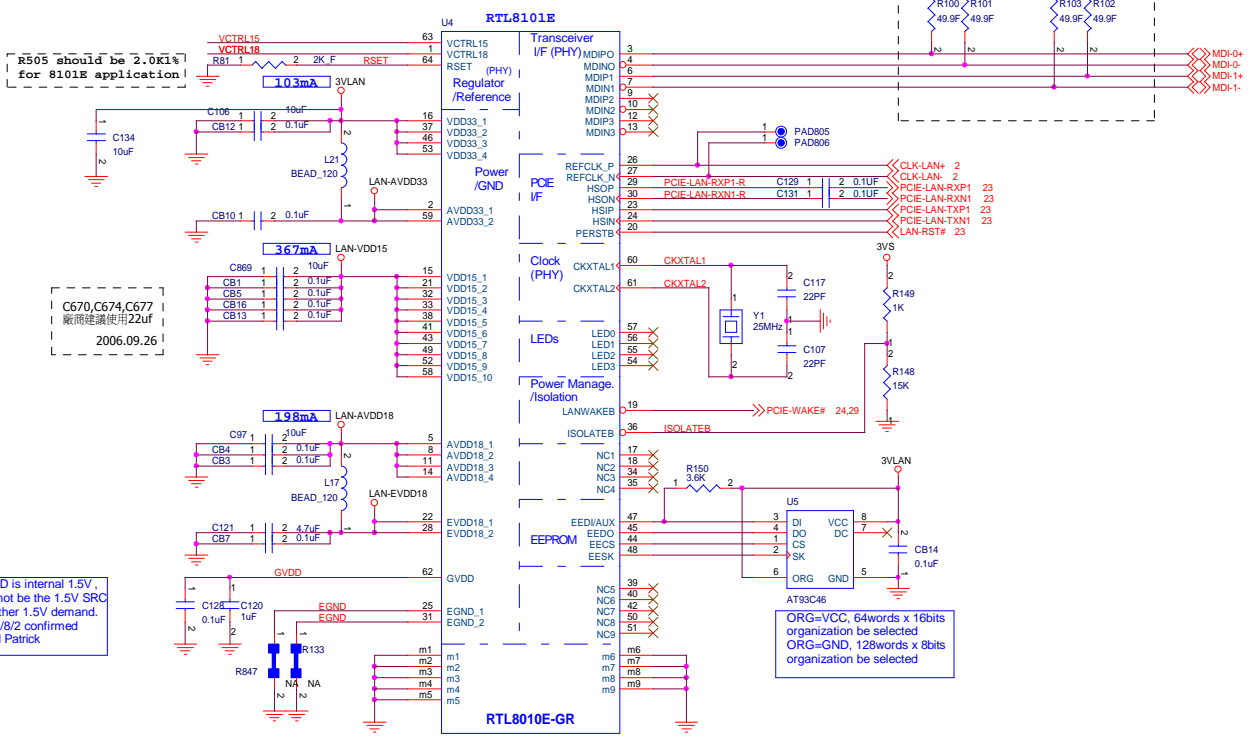

ORG=VCC, 64words x 16bits organization be selected
ORG=GND, 128words x 8bits organization be selected

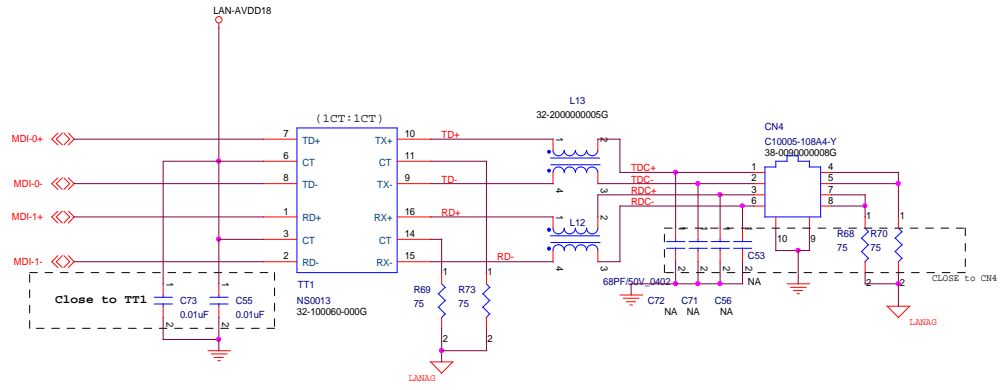
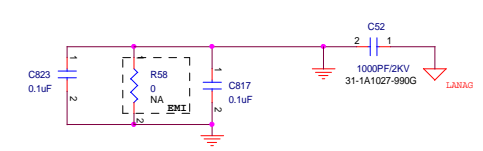
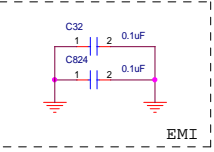

Arima		ARIMA COMPUTER CORP.	
Project Name : W350D11		Title : LAN RTL8101E	
Size : 19.7x12.5	Document Number : 40GAB1700-E110	Rev : E	
Date : Thursday, June 21, 2007		Sheet : 30 of 44	

USB CON

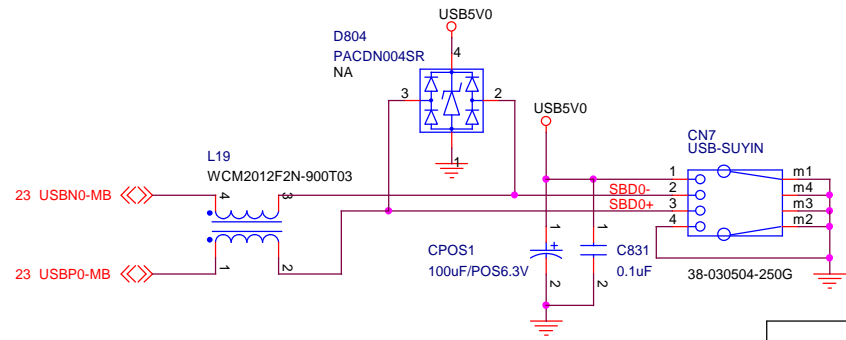

CPOS1.CT1.CPOS6.CPOS801
 1ST 31-211078-130G 100u
 2ND 31-0700000011G 150u

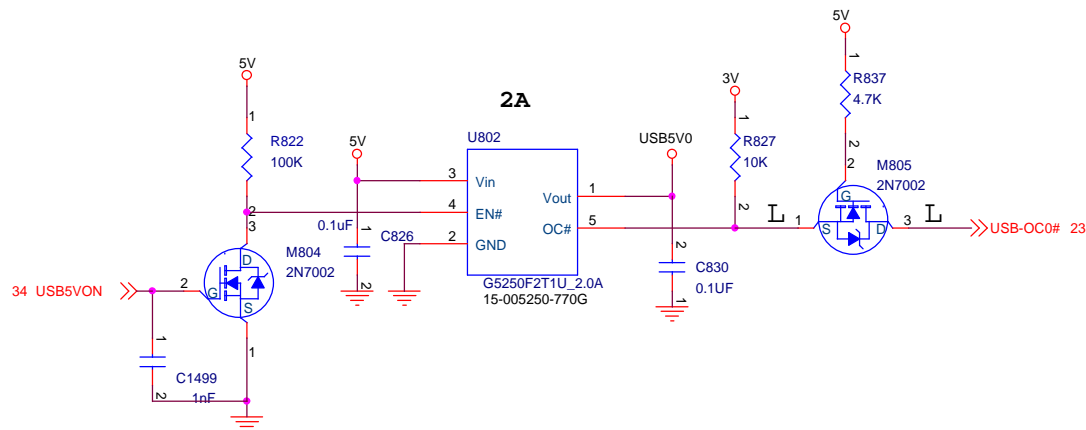
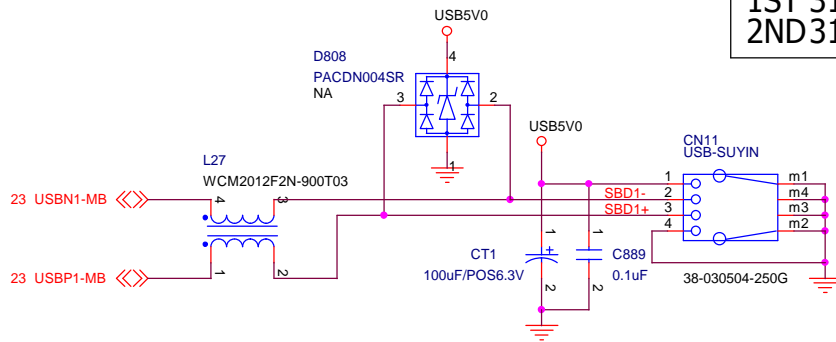

USB DAUGHTER CONNECTOR

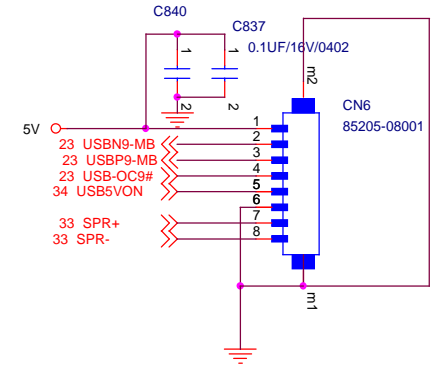

Arima

ARIMA COMPUTER CORP.

Project Name : W350D11		Title : USB CON/80 PORT /BIOS	
Size : 19.7x12.5	Document Number : 40GAB1700-E110		Rev : E
Date: Thursday, June 21, 2007			Sheet: 31 of 44

AUDIO CODEC

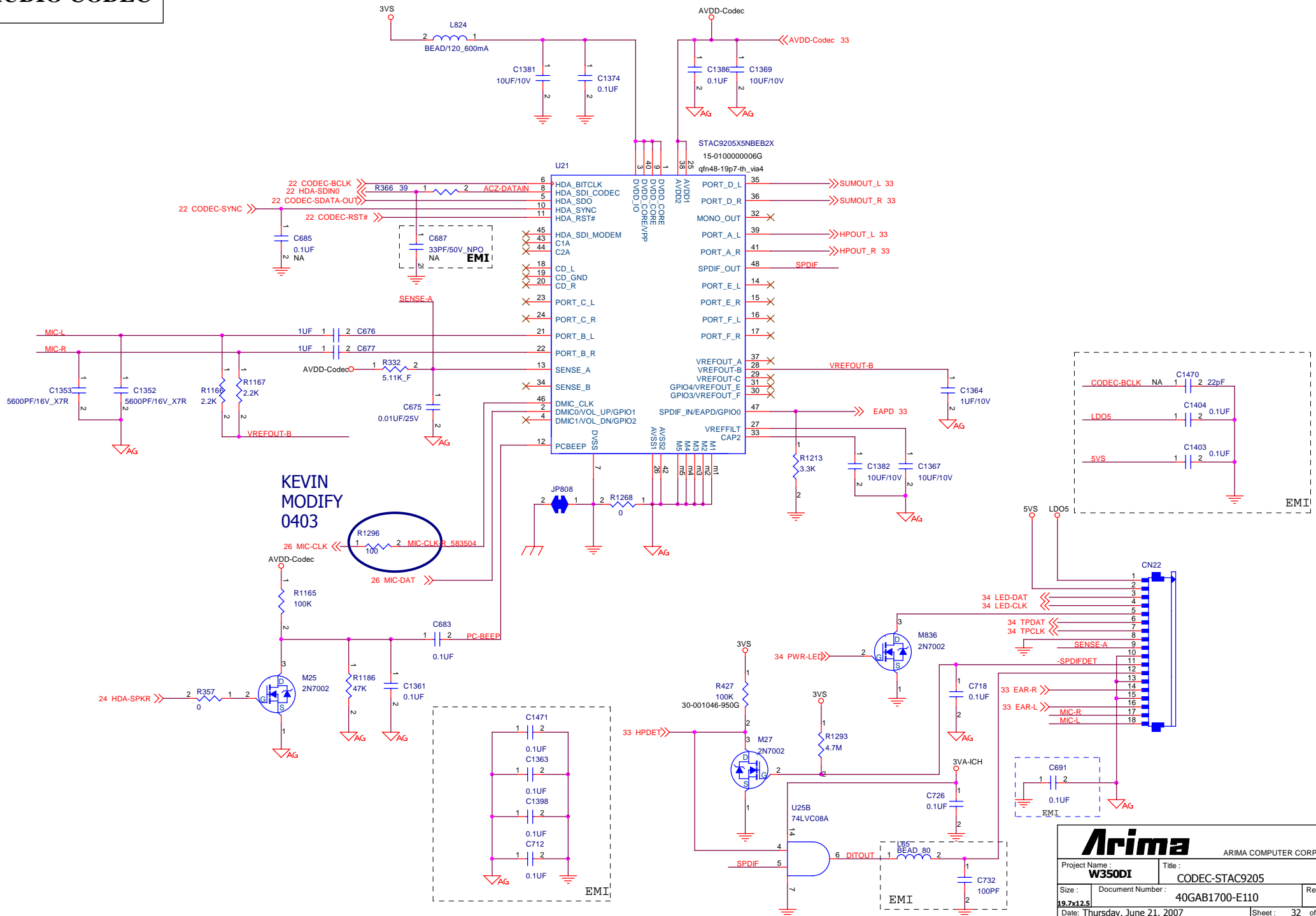

KEVIN
MODIFY
0403

Arima ARIMA COMPUTER CORP.

Project Name : W350DI	Title : CODEC-STAC9205
Size : 19.7x12.5	Document Number : 40GAB1700-E110
Date : Thursday, June 21, 2007	Rev : E
Sheet : 32 of 44	

AUDIO AMP

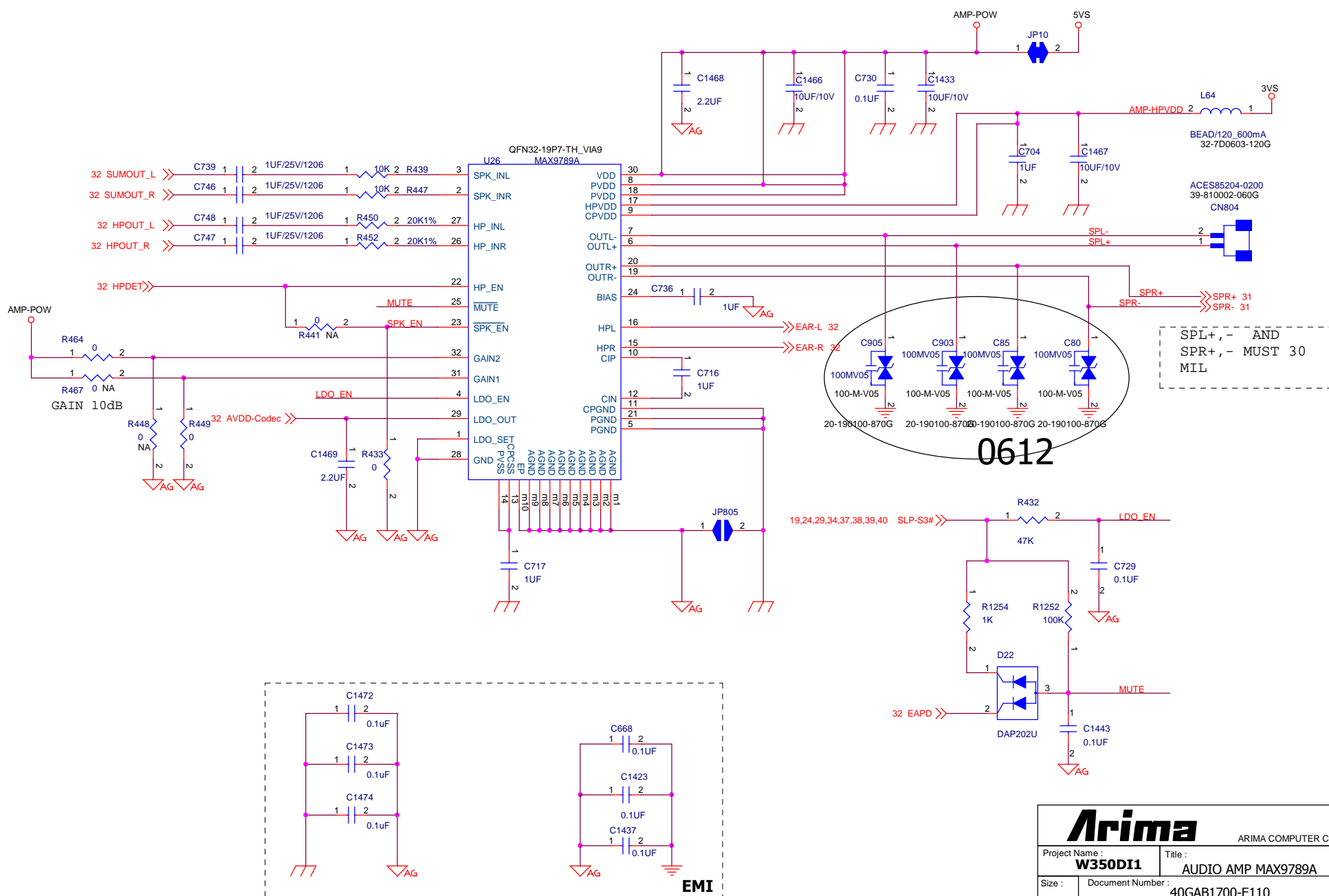

Arima		ARIMA COMPUTER CORP.	
Project Name : W350D11		Title : AUDIO AMP MAX9789A	
Size : 14x10.5	Document Number : 40GAB1700-E110	Rev : E	
Date : Friday, June 22, 2007		Sheet : 33 of 44	

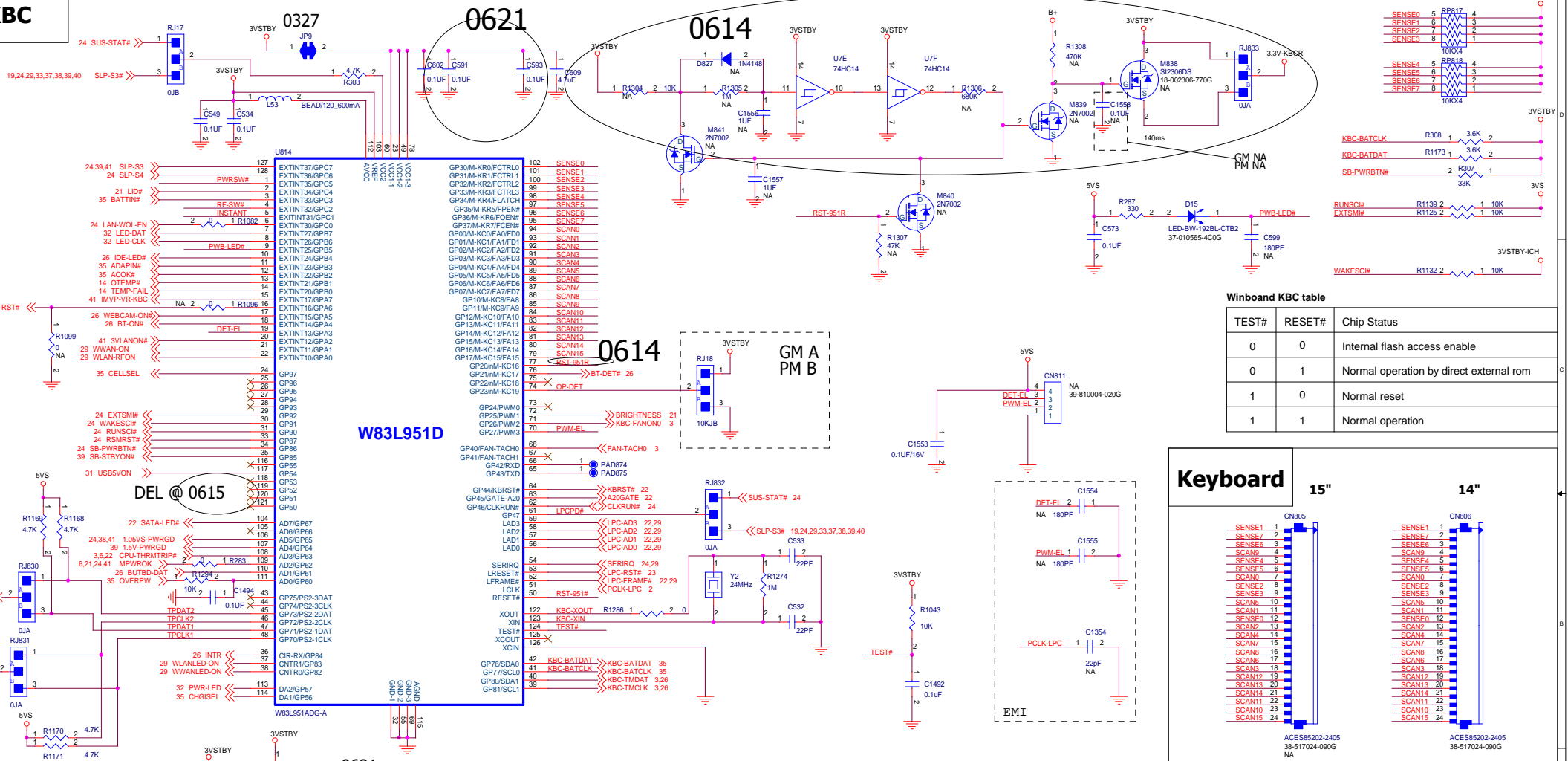

Winboard KBC table

TEST#	RESET#	Chip Status
0	0	Internal flash access enable
0	1	Normal operation by direct external rom
1	0	Normal reset
1	1	Normal operation

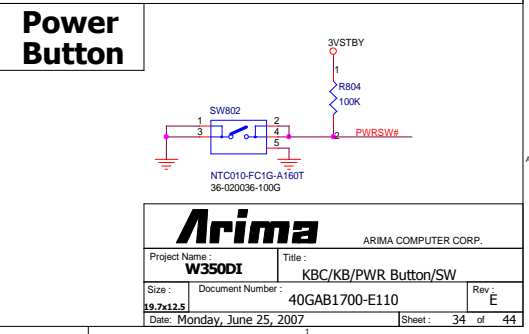
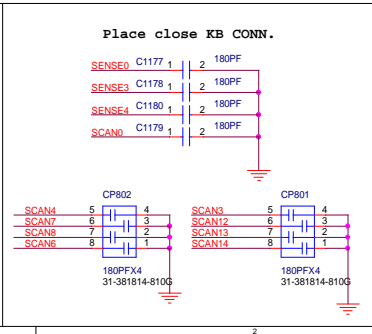
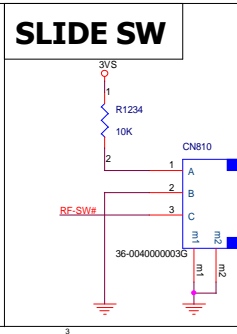
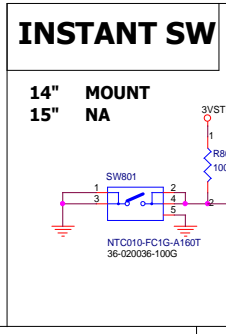
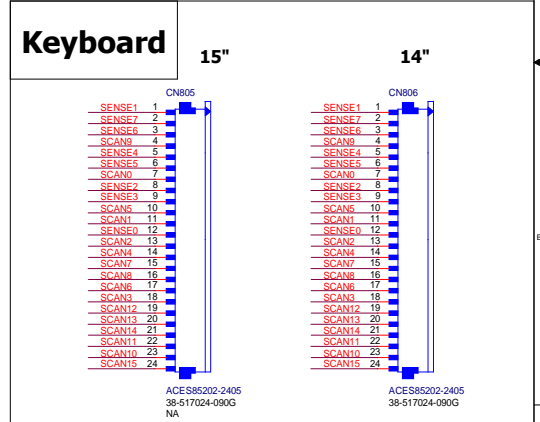

Arima ARIMA COMPUTER CORP.

Project Name: **W350DI** Title: **KBC/KB/PWR Button/SW**

Size: **19.7x12.5** Document Number: **40GAB1700-E110** Rev: **E**

Date: Monday, June 25, 2007 Sheet: 34 of 44

CHARGER / AC_IN

	Net NAME	over power IINP voltage	over power current	Throttling
GM965	OVERPW	2.39V	3.15A	50%
PM965	90W adapter would not over, so Triton DI KBC don't care.			

0403 Max Input Current 3.2A

NB	R856
GM965	30-120021-950G 20K1%ohm-0603
PM965	30-135721-950G 35.7K1%ohm-0603

CELLSEL=Hi : Charge Voltage=16.8V
 CELLSEL=Low : Charge Voltage=12.6V

High 4 Cell
 Low 3 Cell

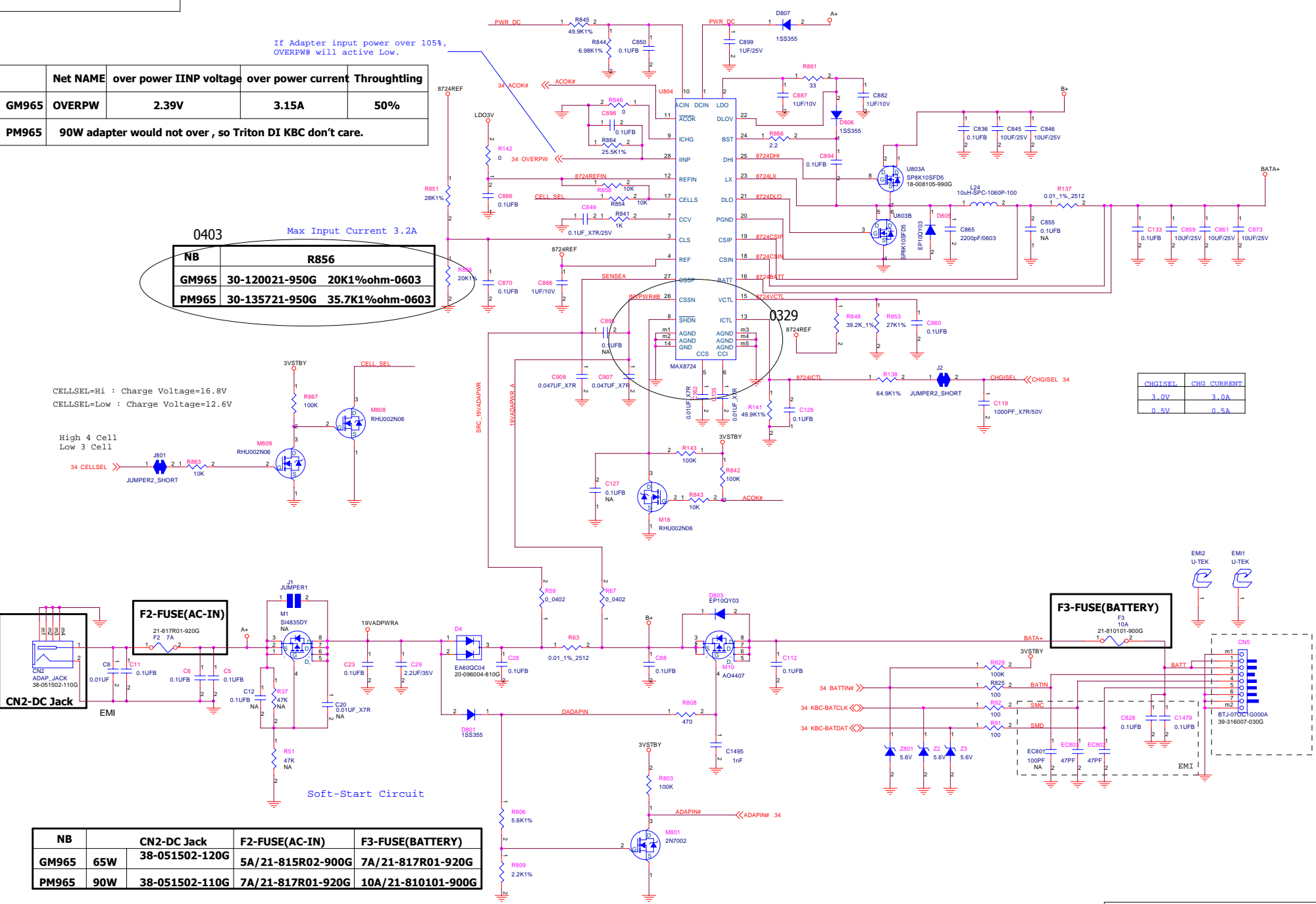

CHGISSEL	CHG CURRENT
3.0V	3.0A
0.5V	0.5A

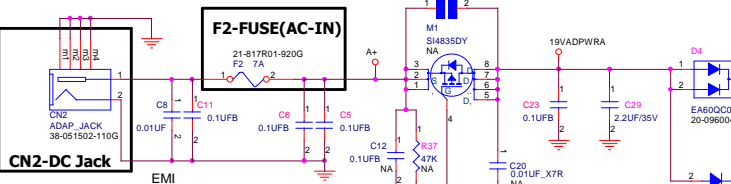

NB	CN2-DC Jack	F2-FUSE(AC-IN)	F3-FUSE(BATTERY)
GM965	65W 38-051502-120G	5A/21-815R02-900G	7A/21-817R01-920G
PM965	90W 38-051502-110G	7A/21-817R01-920G	10A/21-810101-900G

CPU VCORE

NB-PWROK internal delay = 3-8ms
 CLK-GEN-PWRGD# internal delay = ?ms

24 VR-PWRGD-CLKEN#
 6.24 NB-PWROK

IMVP-VR-ON RC delay = 0.9us
 $t = 0.69RC = 0.69 \times 9k \times 100p = 0.621 - 0.9us$

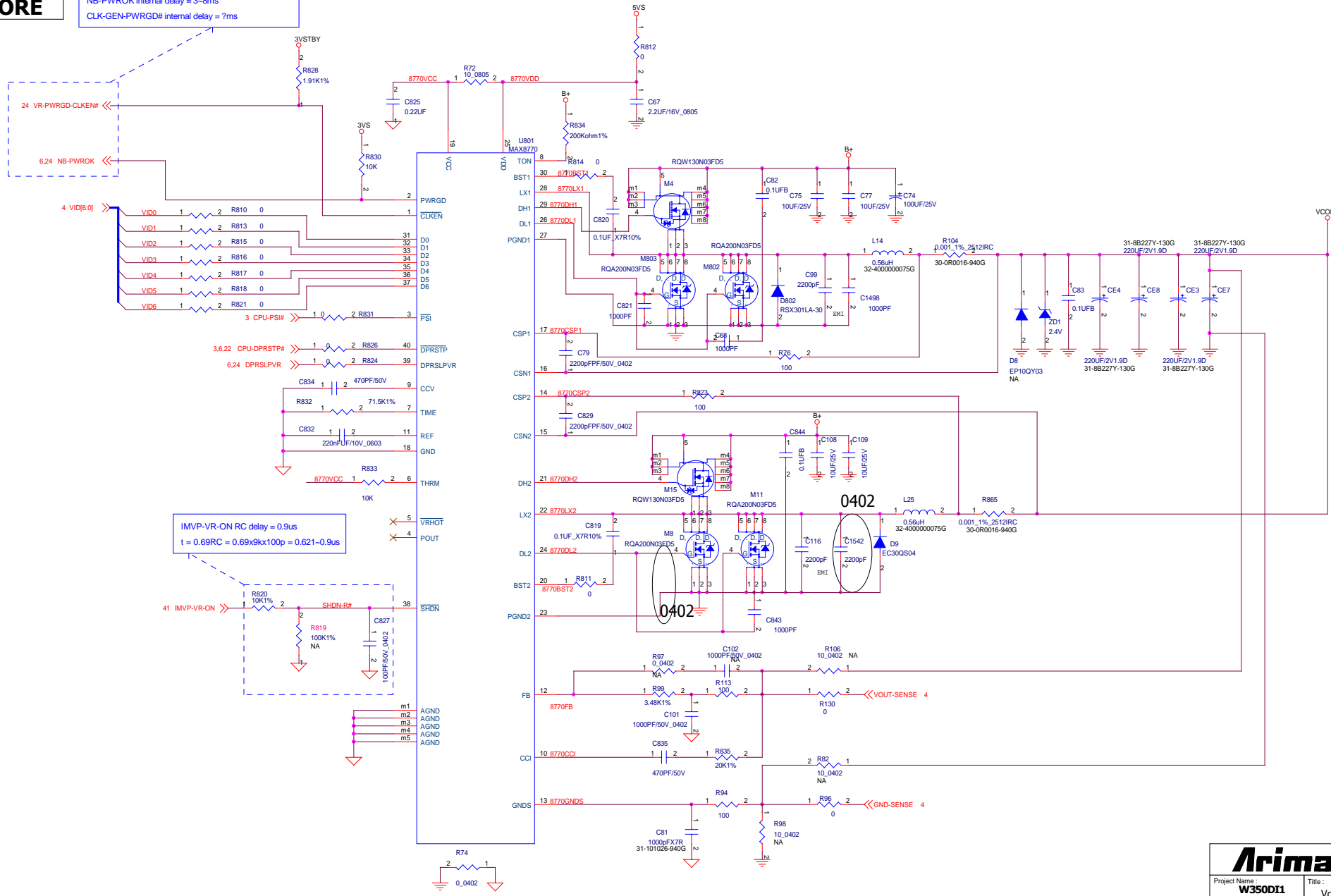

3VSTBY /5V

3.3V/4Amax

5V/5Amax

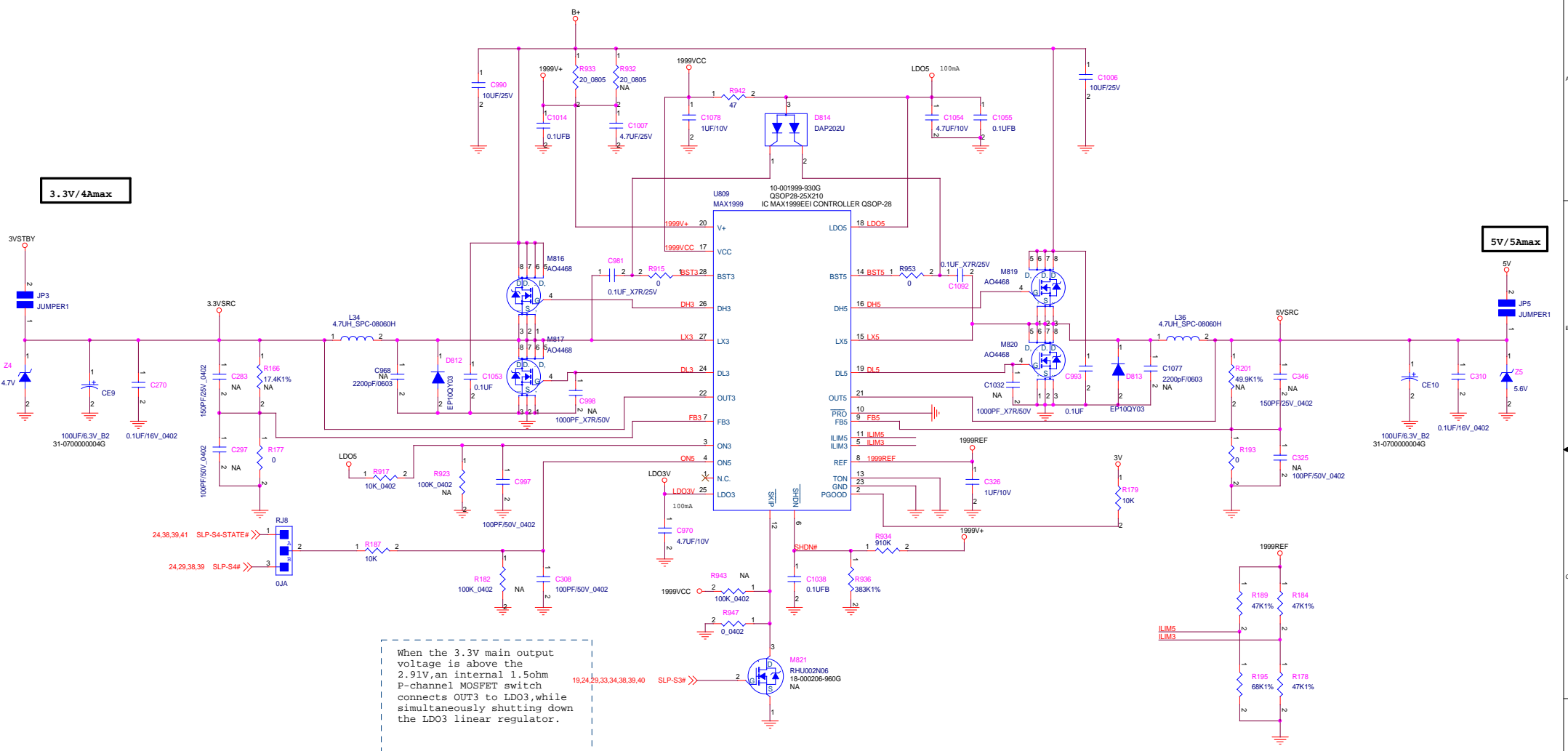

When the 3.3V main output voltage is above the 2.91V, an internal 1.5ohm P-channel MOSFET switch connects OUT3 to LDO3, while simultaneously shutting down the LDO3 linear regulator.

-SKIP connect to:
 Floating for ultrasonic mode
 VCC for PWM mode
 GND for normal idle-mode

Arima			ARIMA COMPUTER CORP.
Project Name : W350D1		Title : 3VSTBY/5V	
Size : 19.7x12.5	Document Number : 40GAB1700-E110	Rev : E	
Date : Thursday, June 21, 2007			Sheet : 37 of 44

Input level	Condition	Min.	Typ.	Max.
Logic input low voltage	EN/PSV Low			1.2
Logic input high voltage	EN high, PSV Low (floating)		2.0	
Logic input high voltage	EN/PSV High	3.1		

19,24,29,33,34,37,39,40 SLP-S3#

24,34,41 1.05VS-PWRGD

1.05VS(RC)=6.8ms+3.6ms=10.4ms

1.05VS

1.8V

EN/ PSV high to PGD high ramp time:
 $Time=(1/\text{switching frequency}) * 440$
 $= (1/150K) * 440$
 $= 2.933ms$

24,29,37,39 SLP-S4#

24,37,39,41 SLP-S4-STATE#

0.2A

R883
 GM 49.9Kohm
 30-149921-950G
 PM 20Kohm
 30-120021-950G

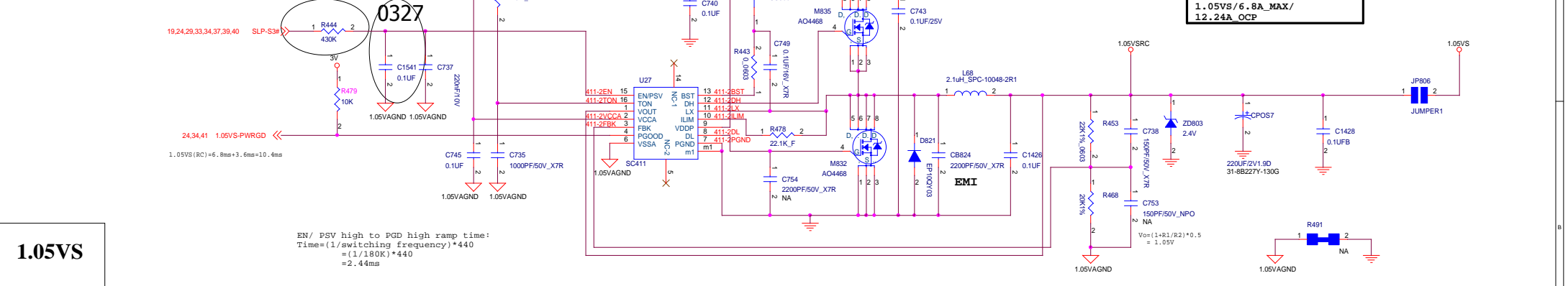

EN/ PSV high to PGD high ramp time:
 $Time=(1/\text{switching frequency}) * 440$
 $= (1/180K) * 440$
 $= 2.44ms$

**1.05VS/6.8A_MAX/
 12.24A_OCP**

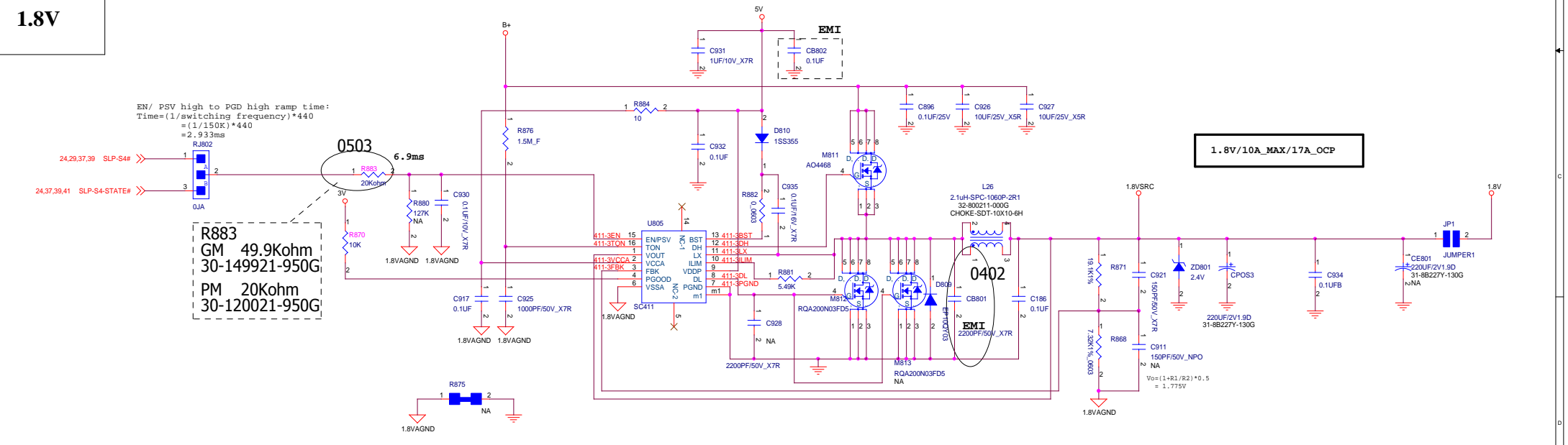

1.8V/10A_MAX/17A_OCP

Arima ARIMA COMPUTER CORP.

Project Name: W350D11	Title: 1.05VS/1.8V
Size: 19.7x12.5	Document Number: 40GAB1700-E110
Date: Thursday, June 21, 2007	Rev: E

Sheet: 38 of 44

0.9V

0.9V/2Amax

Connect from DDR DIM

Close to 1.8V

0320

0417

0404

$$0.9V(RC) = 4.7ms + 1ms = 5.7ms$$

IC pin to pin 2nd source:
TI TPS51100
15-051100-110G

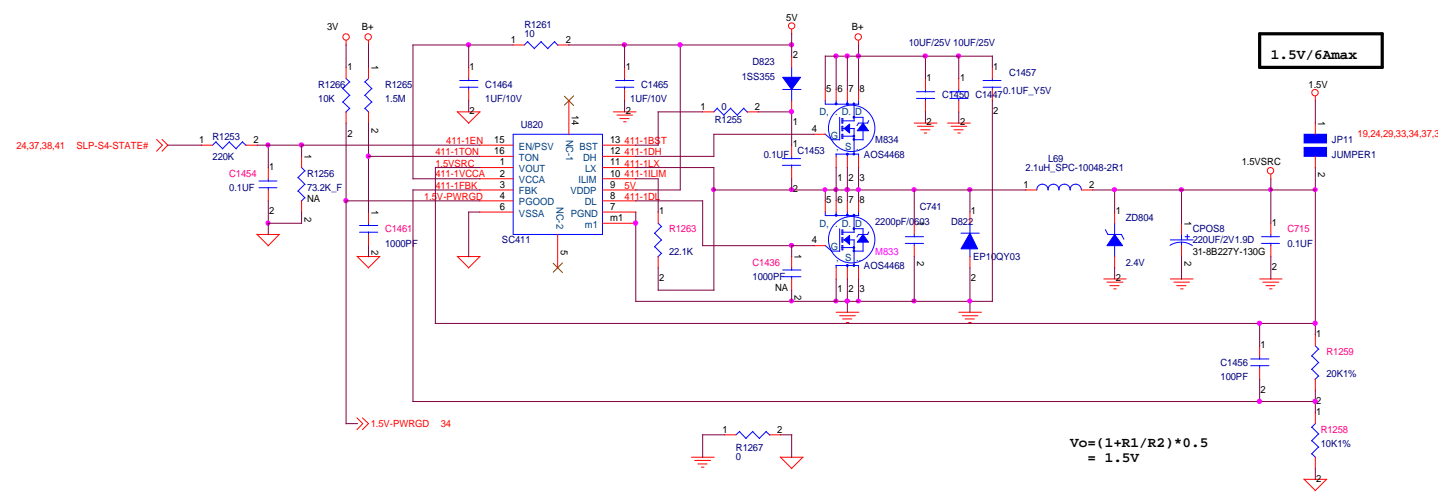

$$Vo = (1 + R1/R2) * 0.5 = 1.5V$$

3VSTBY-ICH

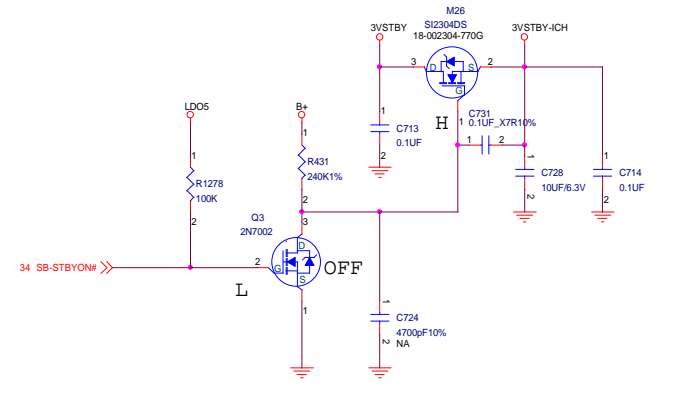

1.5V/6Amax

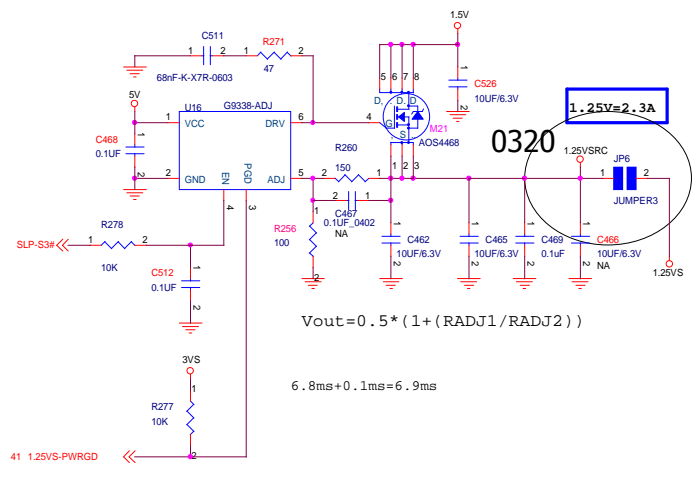

$$Vout = 0.5 * (1 + (RADJ1/RADJ2))$$

$$6.8ms + 0.1ms = 6.9ms$$

Arima		ARIMA COMPUTER CORP.	
Project Name: W350D11		Title: 0.9V/3VSTBY-ICH/1.5V/1.25V	
Size: 19.7x12.5	Document Number: 40GAB1700-E110	Rev: E	
Date: Thursday, June 21, 2007		Sheet: 39 of 44	

VGA CORE

C1329
GM 470nF 31-4F4749-940G
PM 220nF 31-482249-940G

0507

0409

0512

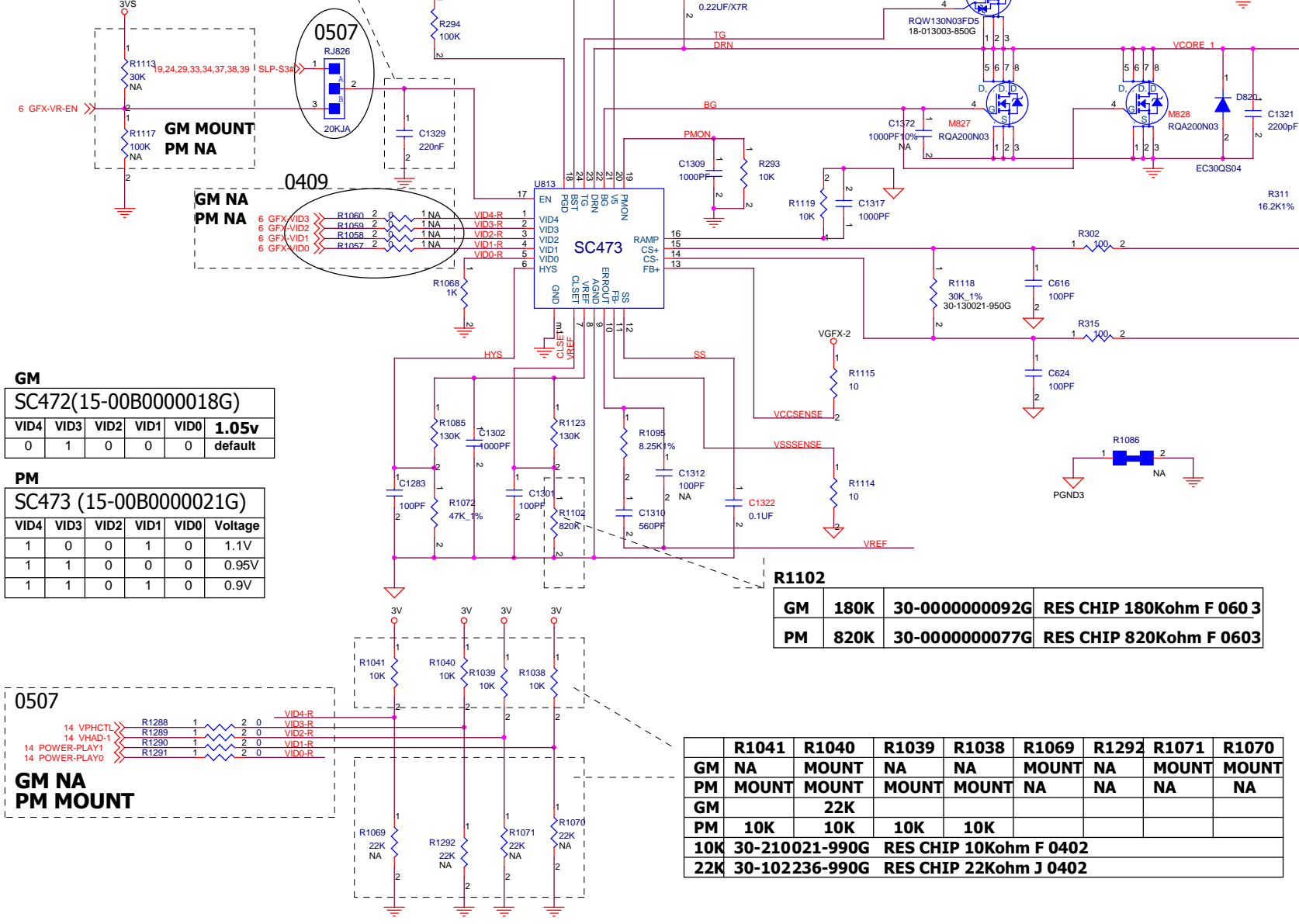

GM						
SC472(15-00B0000018G)						
VID4	VID3	VID2	VID1	VID0	1.05v	
0	1	0	0	0	default	

PM						
SC473 (15-00B0000021G)						
VID4	VID3	VID2	VID1	VID0	Voltage	
1	0	0	1	0	1.1V	
1	1	0	0	0	0.95V	
1	1	0	1	0	0.9V	

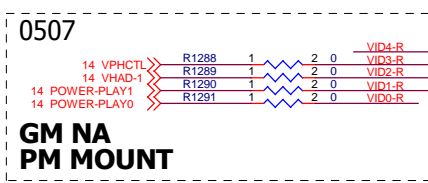

GM NA
PM MOUNT

R1102						
GM	180K	30-000000092G	RES CHIP 180Kohm F 060 3			
PM	820K	30-000000077G	RES CHIP 820Kohm F 060 3			

	GM: IMVP6+ uma	PM:Ext Graphic
	SC472B	SC473
POP	R1251/R879 (VID)R1017/R1222	(VID)R1019/R1223
NO POP	L2/Q4/C90/C89 (VID)R1019/R1223	R1251/R879 (VID)R1017/R1222
CHANGE	R1170 for OCP	R1170 for OCP

	R1041	R1040	R1039	R1038	R1069	R1292	R1071	R1070
GM	NA	MOUNT	NA	NA	MOUNT	NA	MOUNT	MOUNT
PM	MOUNT	MOUNT	MOUNT	MOUNT	NA	NA	NA	NA
GM		22K						
PM	10K	10K	10K	10K				
10K	30-210021-990G RES CHIP 10Kohm F 0402							
22K	30-102236-990G RES CHIP 22Kohm J 0402							

Arima

ARIMA COMPUTER CORP.

Project Name: W350D11		Title: GRAPH-VID-CTRL/1.1V	
Size: 19.7x12.5	Document Number: 40GAB1700-E110		Rev: E
Date: Thursday, June 21, 2007			Sheet: 40 of 44

VS Plane

5VS delay after SLP-S3 = 0ms
 $t = 17002(\text{on}) + 14800(\text{on}) + 0.69RC = 20\text{ns} + 7\text{ns} = 27\text{ns}$
 $t = 17002(\text{off}) + 14800(\text{off}) + 0.38RC = 20\text{ns} + 32\text{ns} = 52\text{ns}$

3V delay after SLP-S3 = 0ms
 $t = 17002(\text{on}) + 14800(\text{on}) + 0.69RC + RC = 20\text{ns} + 7\text{ns} + 3.2\text{ms} = 3.2\text{ms}$
 $t = 17002(\text{off}) + 14800(\text{off}) + 0.38RC = 20\text{ns} + 32\text{ns} = 52\text{ns}$

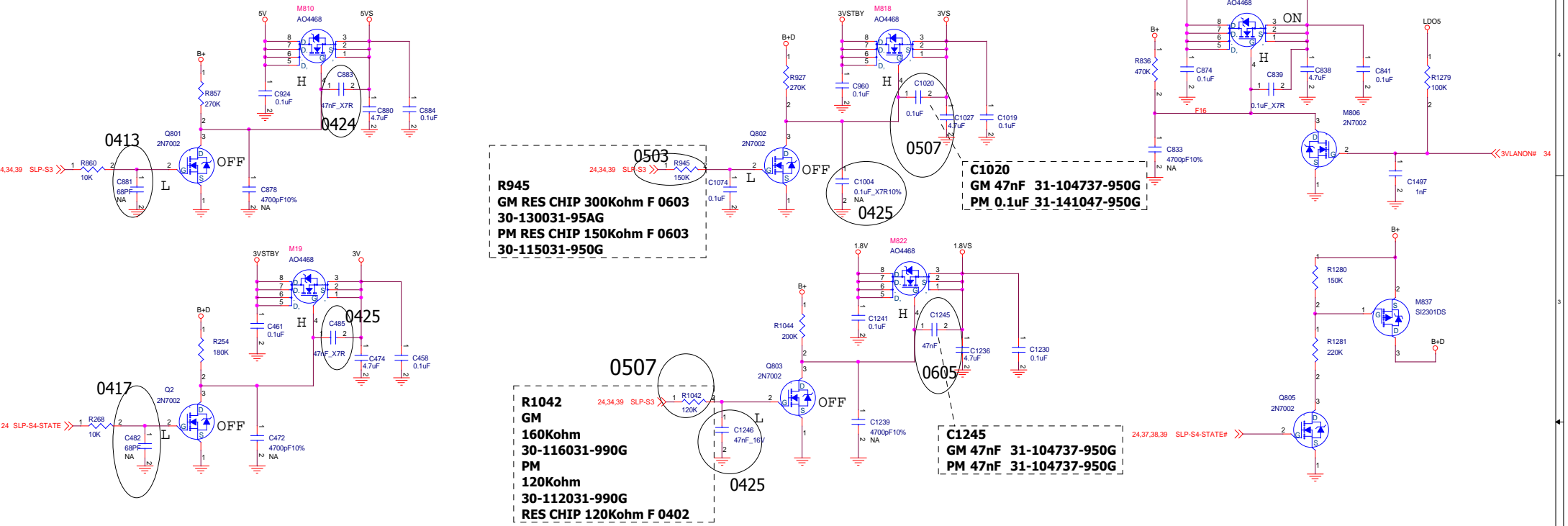

PWRGD

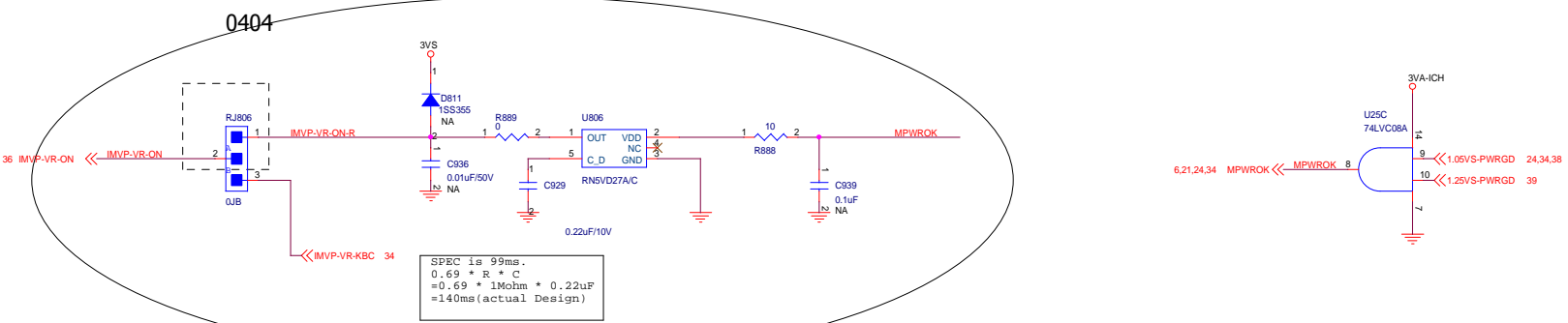

Screw Hole

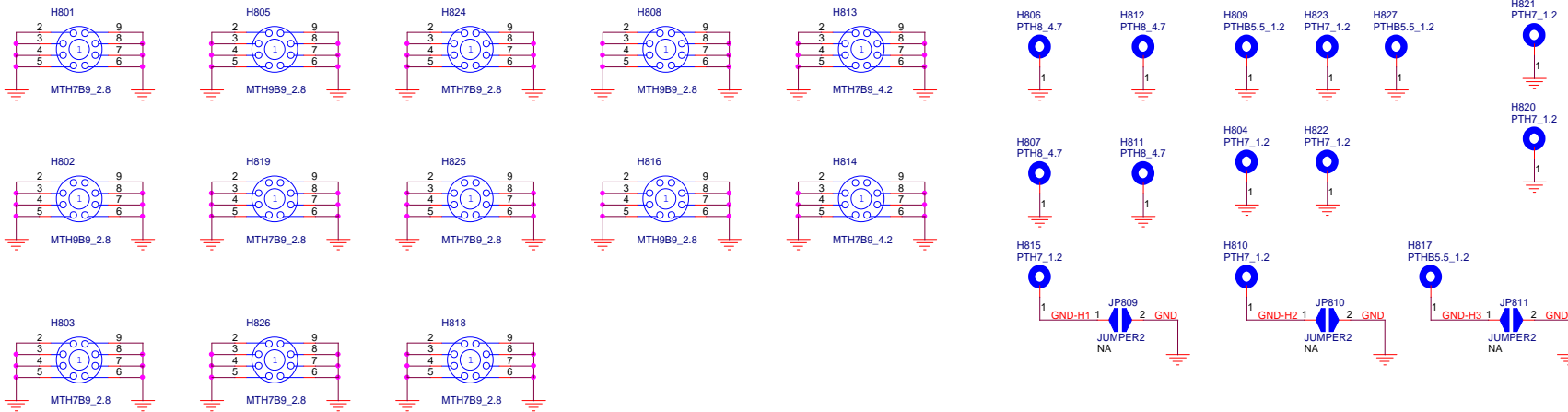

Fiducial Mark

Unused Gates

Moat CAP

FID804

FIDUCIAL
 本PIN不可接任何信號或電源
 CAD-016
 FIDUCIAL MARK 光學定位用

FID803

FIDUCIAL
 本PIN不可接任何信號或電源
 CAD-016
 FIDUCIAL MARK 光學定位用

FID6

FIDUCIAL
 本PIN不可接任何信號或電源
 CAD-016
 FIDUCIAL MARK 光學定位用

FID8

FIDUCIAL
 本PIN不可接任何信號或電源
 CAD-016
 FIDUCIAL MARK 光學定位用

FID802

FIDUCIAL
 本PIN不可接任何信號或電源
 CAD-016
 FIDUCIAL MARK 光學定位用

FID801

FIDUCIAL
 本PIN不可接任何信號或電源
 CAD-016
 FIDUCIAL MARK 光學定位用

FID7

FIDUCIAL
 本PIN不可接任何信號或電源
 CAD-016
 FIDUCIAL MARK 光學定位用

FID5

FIDUCIAL
 本PIN不可接任何信號或電源
 CAD-016
 FIDUCIAL MARK 光學定位用

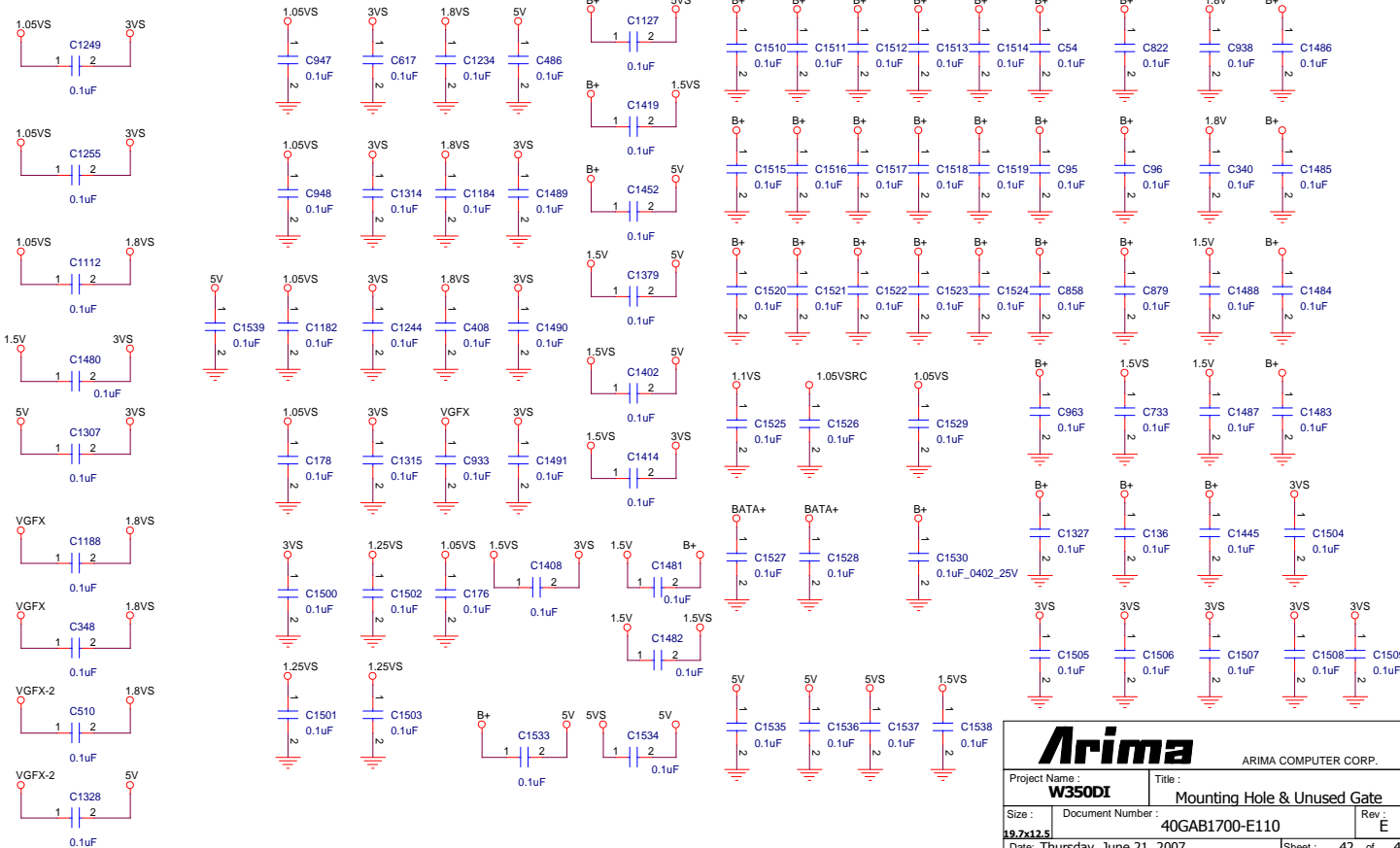
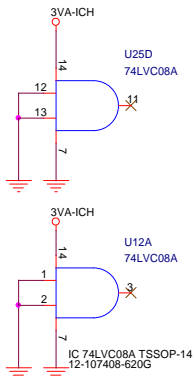

Arima ARIMA COMPUTER CORP.

Project Name: **W350DI** Title: **Mounting Hole & Unused Gate**

Size: **19.7x12.5** Document Number: **40GAB1700-E110** Rev: **E**

Date: Thursday, June 21, 2007 Sheet: 42 of 44

Power Sequence

Last update on
March, 23rd

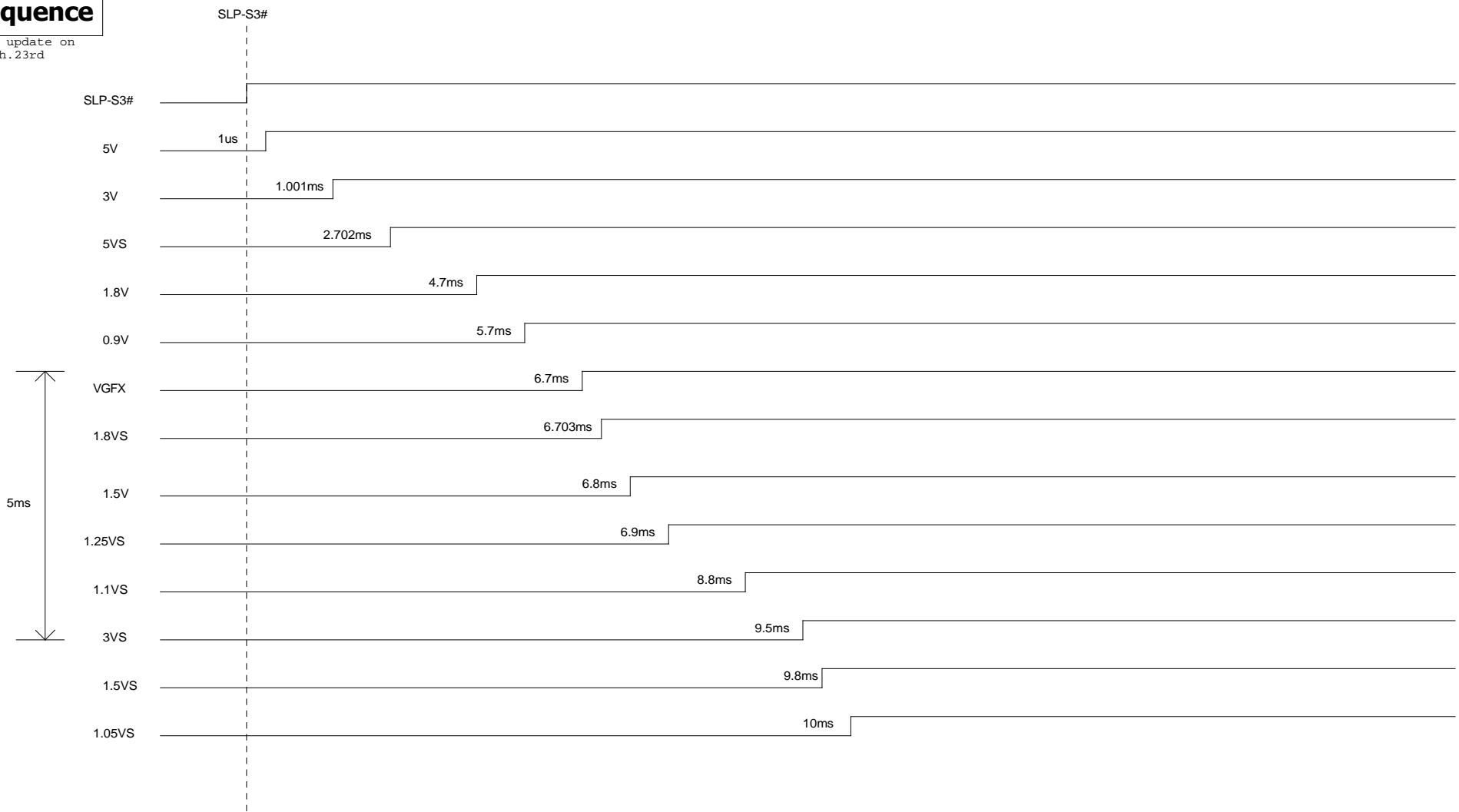

Arima		ARIMA COMPUTER CORP.	
Project Name: W350DI		Title: Power Sequence Chart	
Size: 19.7x12.5	Document Number: 40GAB1700-E110	Rev: E	
Date: Thursday, June 21, 2007		Sheet: 43	of 44

Release Note

M/B P/N: 40GAB1700-A to 40GAB1700-B

Item	Description	Page
1	R898 · R887 change to 2.2Kohm ·	3
2	Remove R191 for cost down ·	5
3	Change C1013 material to 31-0700000004G for over height bug when build system ·	8
4	R989 change to NA for modify strapping ·	10
5	Remove test pad as follow PAD838 · PAD62 · PAD61 · PAD59 · PAD58 · PAD834 · PAD52	14
6	PAD49 · PAD826 · PAD57 · PAD56 · PAD48 · PAD38 · PAD825 · PAD35 · PAD37 · PAD827	14
7	PAD33 · PAD34 · PAD31 · PAD15 · PAD828	14
8	Remove R162 · R163 · R921 · R926 · R911 · R912 · R913 · R893 · R892 · R894 · R891 · R924	14
9	Remove R916 · R920 · R924 · R916 · R920	14
10	Add RJ828 · RJ829 (Netname DVPDATA22 · DVPDATA23)	14
11	Add PAD900 · PAD901 · PAD902 · PAD903 · PAD904 · PAD905 · PAD906 · PAD907	14
12	Remove C1040 · C1044 · C1057 · C1069 · C1119 · R948 · R950 · PAD862 · PAD866 ·	15
13	CE802 change material · Add C1475 · C1476 · C1477 · C1478 · for 0.1uF Moat CAP ·	15
14	R975 · R981 change to 2.2Kohm · JP801 change footprint to jumper1 ·	16
15	Del HDMI EEPROM schematic · U812 · C1240 · Add test pad PAD908 · PAD909 ·	20
16	R1048 change to 680ohm · R252 · R259 · R269 · R274 change to 200ohm ·	20
17	Lid switch change to hall sensor SW803 · SW804 ·	21
18	U819 · R1220 mount ·	23
19	R1154 · R1133 mount ·	24
20	Remove C1407 · C1396 · C1392 ·	25
21	CN808 footprint 水平翻轉180度 · CN12 pin 37 add netname IDE-LED# to KBC chip ·	26
22	CN802 change to 8 pins · pin7 netname "INSTANT" to KBC chip net instant switch ·	26
23	Net swap · L823.1 to L823.4 · L823.3 to L823.2 · (From layout house request)	26
24	L819 modify footprint · Reomve D13 · CB36 C	27
25	U23 · change 1394a chip to DNP FW322-100 · Schematic follow W350UA1 ·	27
26	U818 · change CardReader chip to RTS5158 · CN809 · modify footprint ·	28
27	CN17 modify footprint to cn-minipci52-7h-rv · U817 change to BD4154FV ·	29
28	CN4 modify footprint ·	30
29	U21 modify footprint · Add M836 · for netname PWR-LED ·	32
30	C905 · C903 · C85 · C80 change to 200pF · R449 · R447 change to 10Kohm ·	33
30	C1472 · C1473 · C1474 change to 0402 size · C1468 change to 2.2uF ·	33
31	Del netname "MUTE" to KBC chip on D22 ·	33
32	Remove R284 · C568 · D14 · C562 (remove all "INSTANT-LED" signal) ·	34
33	RJ17 pin1 to SUS-STAT# · pin2 to R303 · pin3 to netname "SLP-S3#" ·	34
34	RJ18 pin1 to 3VSTBY · pin2 to U814.74 netname "OP-DET" (OverPower Detet) · pin3 to GND ·	34
35	Netname "SATA-LED#" move to U814.104 · netname "IDE-LED#" move to U814.105 ·	34
36	Add R1275(15ohm) on U811.1 to netname "W-SPI-CS#0" ·	34
37	Add RJ830 · RJ831 · RJ830.2 to page 32 netname "TPDAT" · RJ831.2 netname "TPCLK" ·	34
38	SW801.4 connect to page 26 CN802.7 netname "INSTANT" ·	34
39	R1019 · R1024 change to 15ohm · C532 · C533 change to 22pF ·	34
40	Del netname "LPCPD#" on U814.61 · "MUTE" on U814.19 ·	34
41	Add C1479 for EMI solution ·	35
42	D802 · D9 use new material for height limit solution 20-2000000007G ·	36
43	D9 change to use 20-020050-870G · There are two same material P/N in SAP system ·	36
44	CE3 · CE4 · CE7 · CE8 change to 220uF ·	36
45	R444 change to 180Kohm · R881 change to 5.49Kohm · R883 change to 20Kohm ·	38
46	CE801 change to 220uF · M812 · M813 change to use RQA200N03FD5 · M813 NA ·	38
47	ZD801 · ZD803 mount ·	38
48	R909 change to 36Kohm · R1247 change to 110Kohm · R1253 change to 220Kohm ·	39
49	CPOS8 change to 220uF ·	39
50	Add L827 · HC4516 BEAD CHIP 60ohm 25% 100MHz 6A for B+ noise solution ·	40

M/B P/N: 40GAB1700-A to 40GAB1700-B

Item	Description	Page
51	CE806 move to before JP803 · CE806.1 connect to VGFX · CE806.2 connect to GND ·	40
52	CE5 move to before L827 · CE5.1 connect to B+ · CE5.2 connect to GND ·	40
53	Remove CE6 · C1371 ·	40
54	R293 · R294 · C616 · C624 · R302 · R315 · R313 change to 0402 size ·	40
55	CE804 · CE805 · CE806 change to 220uF · D820 change to use 20-020050-870G · C	40
56	R945 change to use 93.1Kohm · R1042 change to use 115Kohm ·	41
57	H802 · H803 · H805 · H808 · H809 · H816 modify footprint · Add H827 ·	42
58	U7E.11 · U7F.13 connect to GND ·	42
59	C1379.1 netname from B+ change to 1.5V ·	42
60	Add the 0.1uF bypass cap between 1.5V and 3VS (C1480)	42
61	Add the 0.1uF bypass cap between 1.5V and B+ (C1481)	42
62	Add the 0.1uF bypass cap between 1.5V and 1.5VS (C1482)	42
63	Add the 0.1uF bypass cap between B+ and GND (4pcs) C1483-C1486	42
64	Add the 0.1uF bypass cap between 1.5V and GND (2pcs) C1487,C1488	42
65	Add C1489 · C1490 · C1491 0.1uF to GND ·	42

M/B P/N: 40GAB1700-B to 40GAB1700-C

Item	Description	Page
1	R1130 · change to 82ohm from 33ohm ·	2
2	C494 · modify to correct P/N · R897 · change to 1Kohm ·	3
3	Remove C1141 · C1159 · C1163 ·	9
4	R902 · change to 1.27Kohm from 560ohm ·	13
5	Remove L31 · R198 · PAD844 · PAD904 · PAD905 · PAD907 · C R938 · change to 249ohm ·	14
6	R198 change netname to POWER-PLAY and pull-high to 3VS ·	14
7	U9.AB2 add netname "POWER-PLAY0" · U9.AG3 add netname "POWER-PLAY1" ·	14
8	U9.AJ9 add netname "VPHCTL" · U9.AL9 add netname "VHAD-1" and connecto to page40	14
9	Remove C991 · U9D.AR34 netname "PCIE-VDDR" same as "1.8VS" · del first one and use "1.8VS" ·	15
10	R973 use tolerance 1% · R975&R981 change to 4.7Kohm from 2.2Kohm · RJ816 change to 0ohm	16
11	Remove R944 · add R1277 and pull high to 1.8VS	17
12	U11 · U810 change to use 14-00D0000014G (IC GDDR3 HY5RS123235BFP-14 512M FBGA136)	18
13	Remove C361 · C363 · Remove C1083 for layout · Add C1540 10uF · R276 change to 130ohm ·	19
14	R1048 change to 820ohm · R279 and R282 NA ·	20
15	U15.33 netname "VCC-PWR" same as netname "1.8VS" · del "VCC-PWR"	20
16	Add 1nF named C1496 at RJ801.1 · C815 mount 180pF · remove D2 and use 0ohm named R1276	21
17	Add D826 netname "MPWORK" · add 0ohm named R1283 & R1284 at M815 & M814 ·	21
18	R885 · R886 change to 1.82Kohm from 1Kohm	21
19	C1298 · C1299 change to 15pF from 18pF for RTC	22
20	C103 · C1319 · C1325 mount · add C1531 · C1532 · L828 · L829 at CN803 for LC circuit	26
21	CN808 水平翻轉 · Add D824 · D825 bypass to GND · R1006.1 change to 5VS from 3VS	26
22	Add R1285 0ohm at M9 · R129 mount · R840 change to 1Kohm ·	26
23	C1320.2 · CB40.2 · CB810.2 · CB811.2 · CB817.2 · R1066.2 change netname to GND	27
24	U23.74 · U23.76 · U23.87 · U23.92 change netname to GND · Remove CB813 · L825 · R1273	27
25	CB811.1 · CB817.1 · U23.91 · U23.88 · U23.75 change netname to 3VS	27
26	C688 · CN18 NA for not support WWAN ·	29
27	CN6.1 · R822 · R837 change to 5V · R827.1 change to 3V C	31
28	Add 1nF named C1499 bypass between M804 pin2 (Net USB5VON) and GND ·	31
29	Add 47Kohm named R1293 pull high to 3VS ·	32
30	C1423 · C730 change size to 0402 C	33
31	C1223 · C1226 · C1228 · C1229 · C1231 · R1019 · R1022 to R1026 NA · Remove R1051 ·	
32	R1029 · R1030 · R1047 · R1275 · R286 NA · C1177 to C1180 change to 180pF ·	
33		
34		
35		

Arima

ARIMA COMPUTER CORP.

Project Name : W350DI		Title : Release Note	
Size : 19.7x12.5	Document Number : 40GAB1700-E110	Rev : E	
Date : Thursday, June 21, 2007		Sheet : 44 of 44	