

LAYER 1 : TOP
LAYER 2 : GND
LAYER 3 : IN1
LAYER 4 : IN2
LAYER 5 : VCC
LAYER 6 : BOT

LL6_MV Montevina Block Diagram

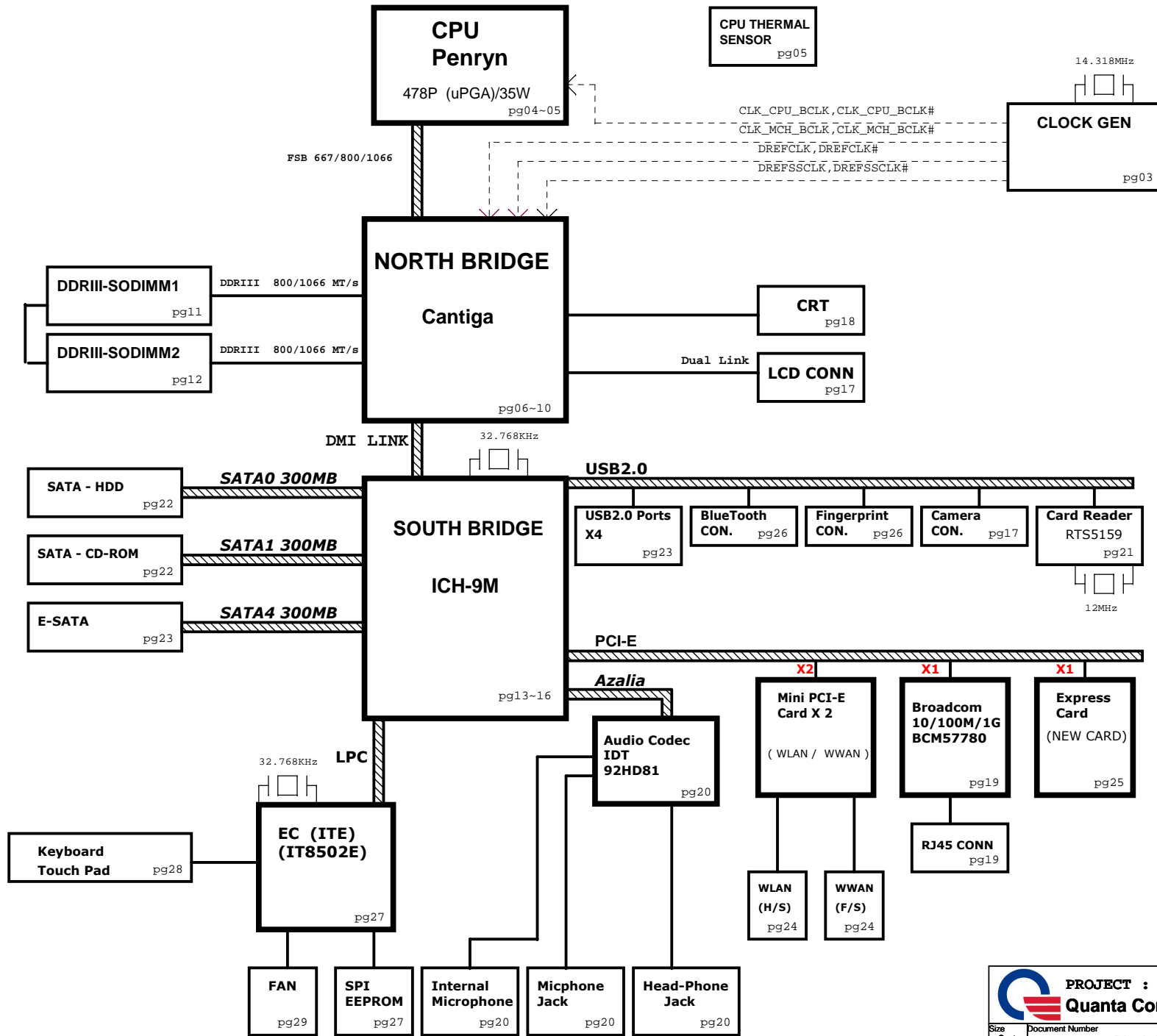

POWER

- CPU CORE (ISL6266A) pg36
- VCCP +1.8V AND GMCH 1.05V (RT8204) pg34
- DDR III (TPS51116REGR) 1.5VSUS/SMDDR_VTERM /SMDDR_VREF pg33
- SYSTEM DISCHARGE pg31
- SYSTEM POWER (ISL6237) pg35
- SYSTEM CHARGER (MAX8731A) pg32

Power States

POWER PLANE	VOLTAGE	PAGE	DESCRIPTION	CONTROL SIGNAL	ACTIVE IN
VIN	10V~+19V	18, 33, 34, 35, 36, 37, 38, 39	MAIN POWER		S0~S5
+3VRTC	+3.0V~+3.3V	13, 16, 32	RTC		S0~S5
3VPCU	+3.3V	13, 18, 22, 24, 30, 32, 33, 34, 36, 37	8051 POWER		S0~S5
5VPCU	+5V	30, 33, 34, 35, 36, 37, 38	LCD/CHARGE POWER		S0~S5
+15V	+15V	18, 26, 33, 37	LARGE POWER	5VPCU	S0~S5
LANVCC	+3.3V	22, 33	LAN POWER	LAN_ON	
5VSUS	+5V	18, 30, 33, 38	SLP_S5# CTRLD POWER	SUSON	
3VSUS	+3.3V	14, 15, 27, 28, 29, 32, 33, 38	SLP_S5# CTRLD POWER	SUSON	
1.8VSUS	+1.8V	10, 33, 36		SUSON	
1.5VSUS	+1.5V	07, 09, 10, 11, 12, 33, 35	SODIMM POWER CALISTOGA/ICH8 POWER	SUSON	
SMDDR_VREF_DIMM	+0.75V	11, 12	SODIMM POWER		
+5V	+5V	16, 17, 18, 19, 21, 23, 24, 25, 32, 33, 34	SLP_S3# CTRLD POWER	MAINON	
+3V	+3.3V	03, 05, 07, 10, 11, 12, 13, 14, 15, 16, 17, 18, 19, 20, 21, 22, 23, 24, 25, 26, 27, 28, 29, 30, 31, 32, 33, 34, 35, 36, 37, 38	SLP_S3# CTRLD POWER	MAINON	
+1.5V	+1.5V	05, 10, 13, 14, 15, 16, 21, 27, 28, 29, 35	CALISTOGA/ICH8 POWER	MAINON	
+1.05V	+1.05V	03, 04, 05, 06, 07, 09, 10, 13, 16, 33, 36, 38	CPU/CALISTOGA/ICH8 POWER	MAINON	
VCC_CORE	+0.7V~+1.77V	04, 05, 33, 38	CPU CORE POWER	VRON	
LCDVCC	+3.3V	18	LCD Power	NT_DISP_ON	
+5VHDD	+5V	23	HDD Power	MAINON	
MBATV	+10V~+17V	32, 34	MAIN BATTERY	D/C#	

	PROJECT : LL6	
	Quanta Computer Inc.	
Size B	Document Number	Rev 1A
FRON TPAGE		
Date: Wednesday, July 15, 2009	Sheet 2 of 36	

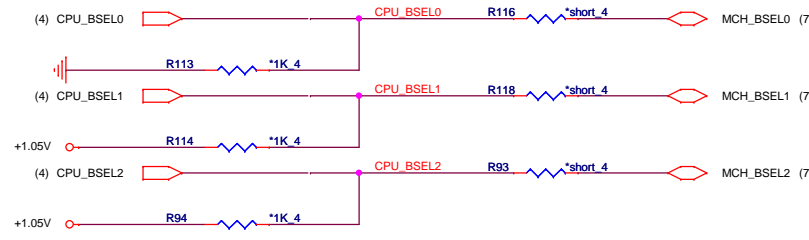
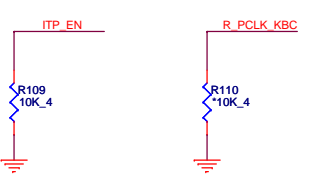
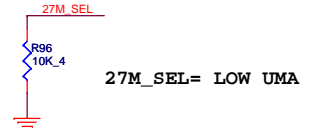
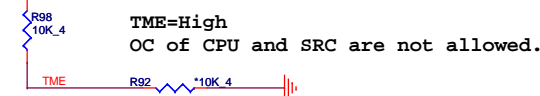
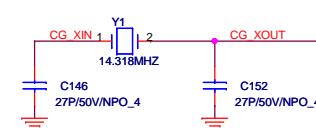
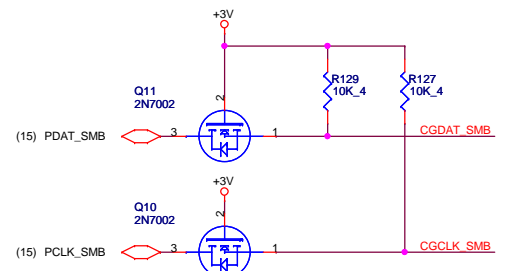
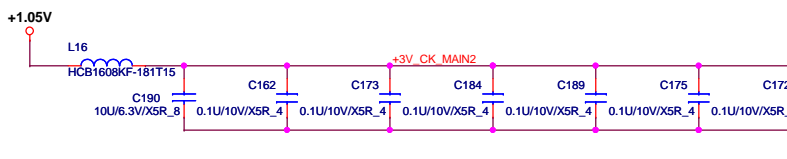
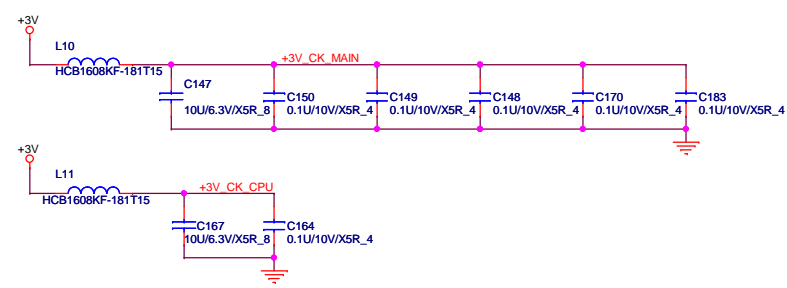

CR#	SRC	CLKREQ	SRC Port
CR#_B	SRC 1,4	CLK_MCH_OE#	SRC4
CR#_A	SRC 0,2	CLK_LAN_OE#	SRC2
CR#_G	SRC 9	CLK_SATA_OE#	SRC9
CR#_H	SRC 10	CLK_MINI_OE#	SRC10

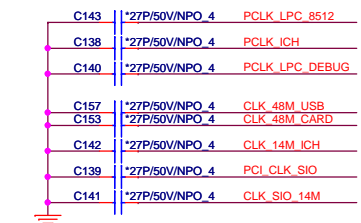
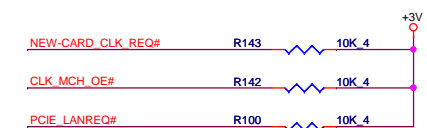
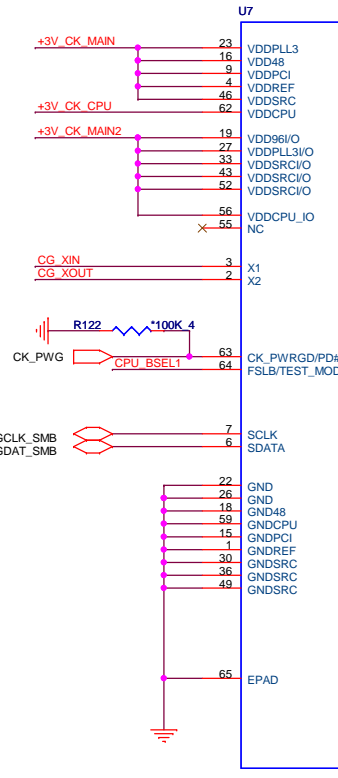

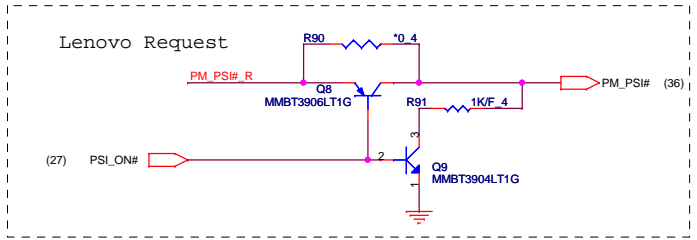
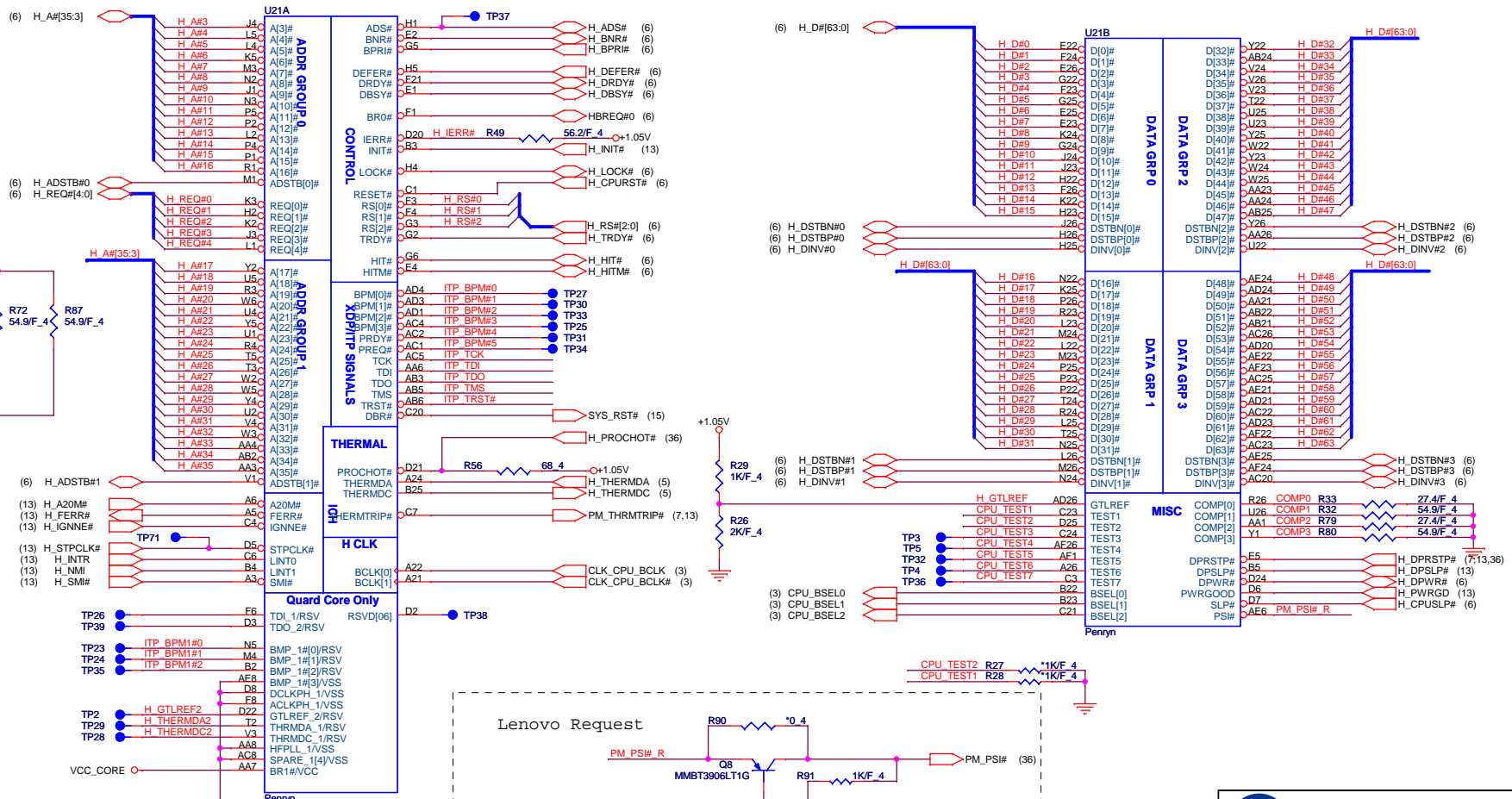

PROJECT : LL6
Quanta Computer Inc.

Size	Document Number	Rev
Custom	Penryn 1/2	1A
Date:	Wednesday, July 15, 2009	Sheet 4 of 36

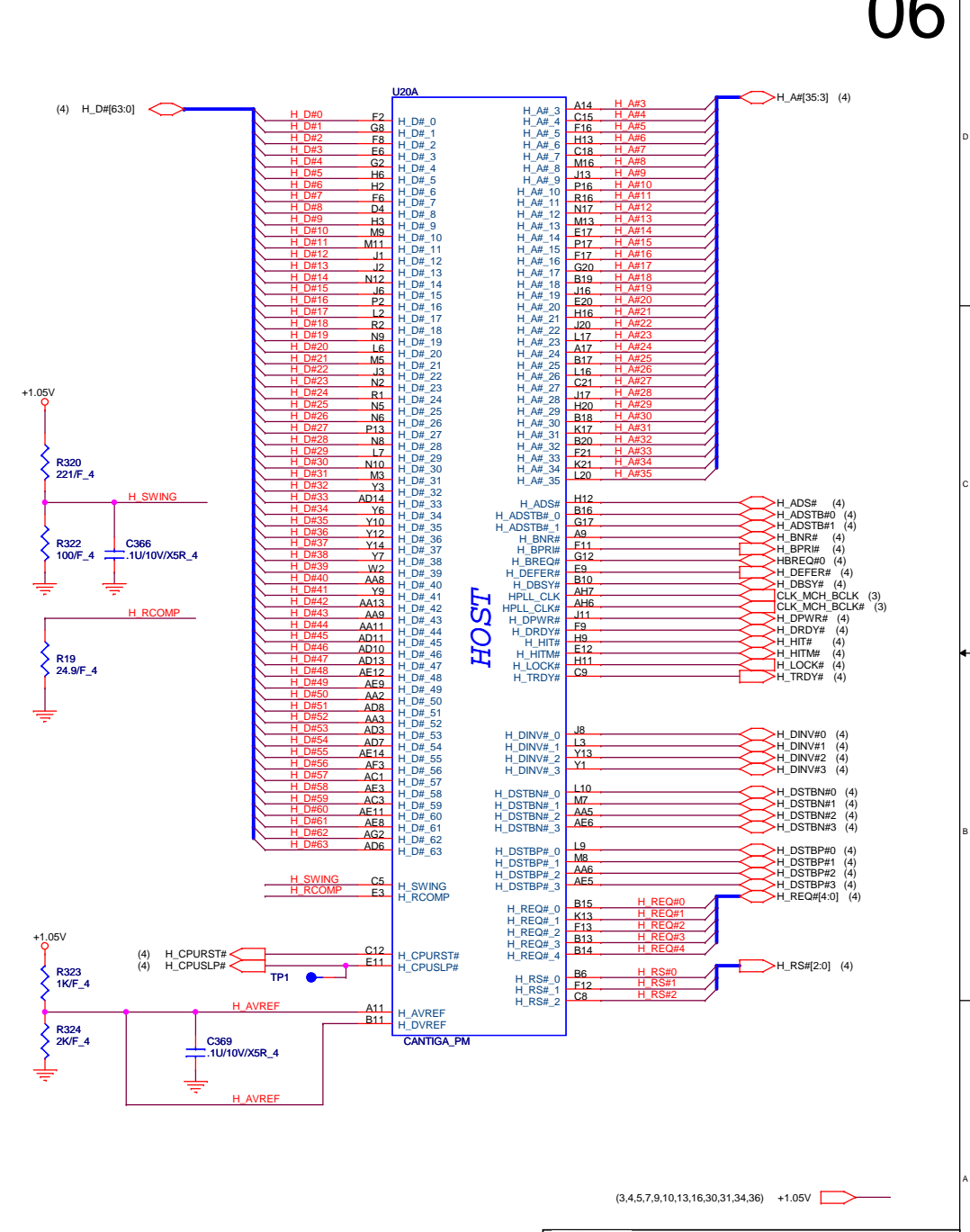
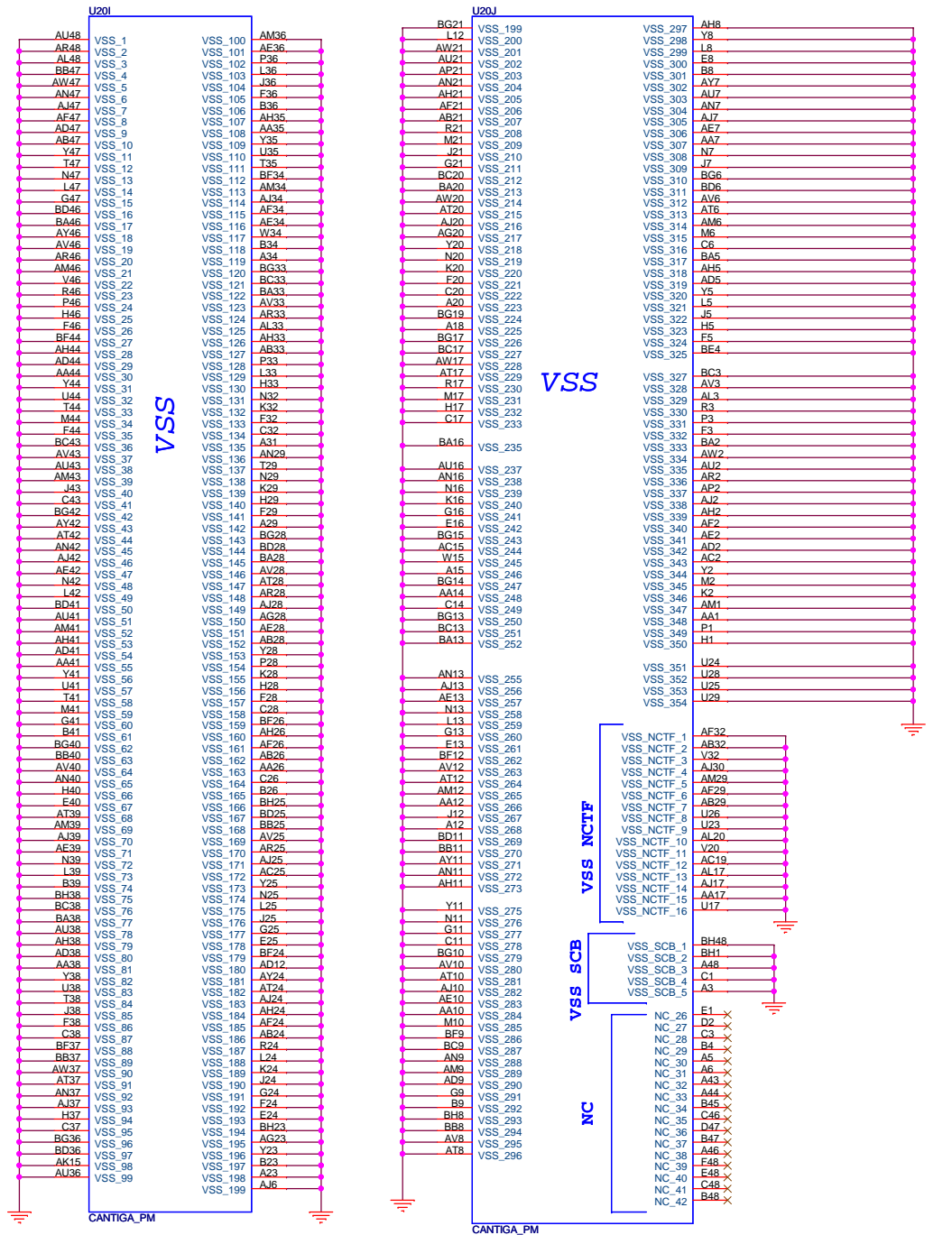

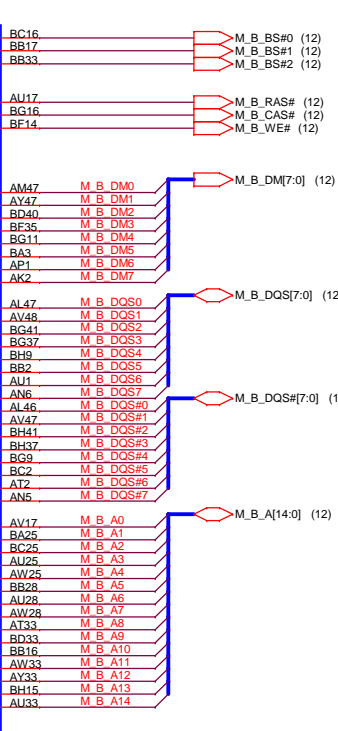
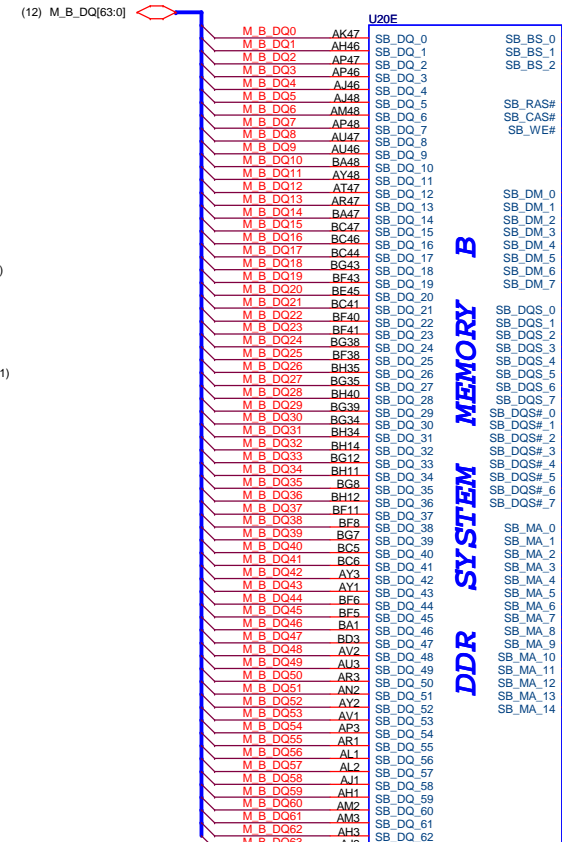
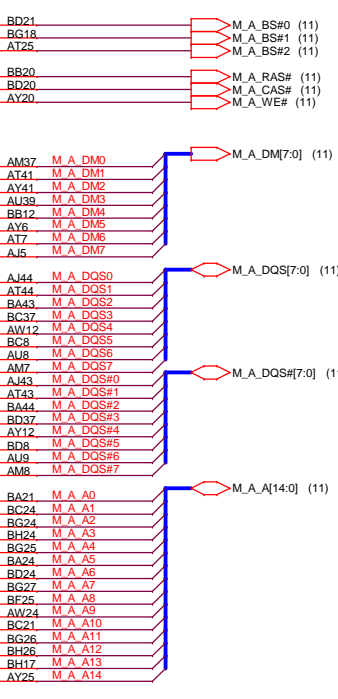
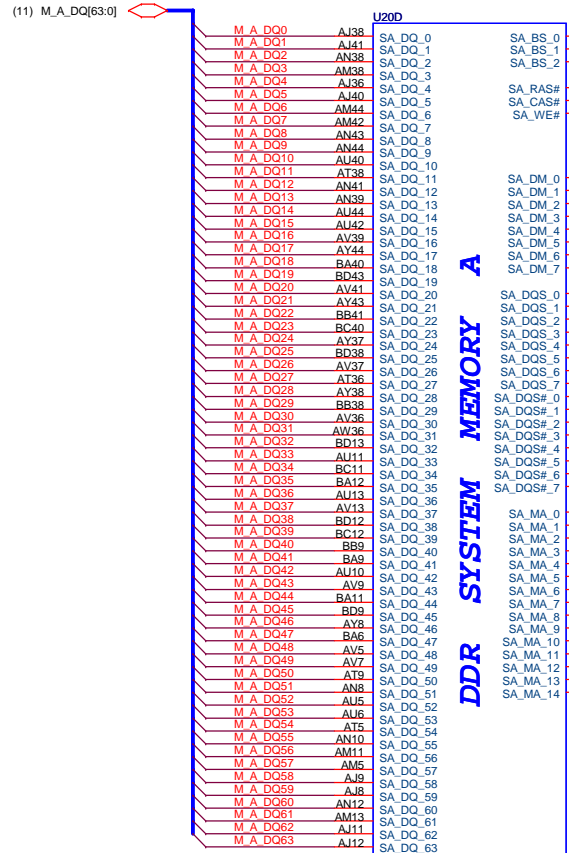

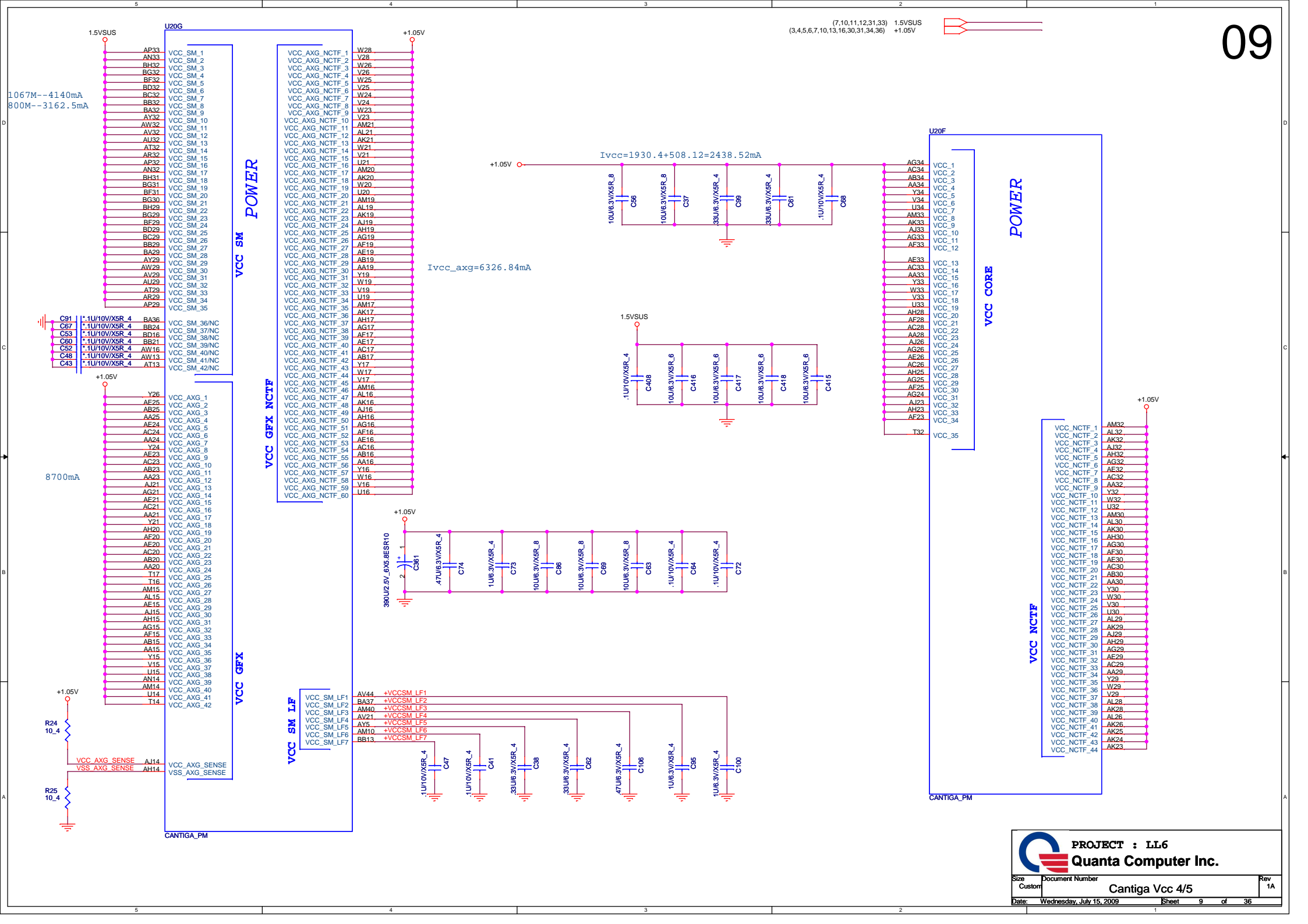

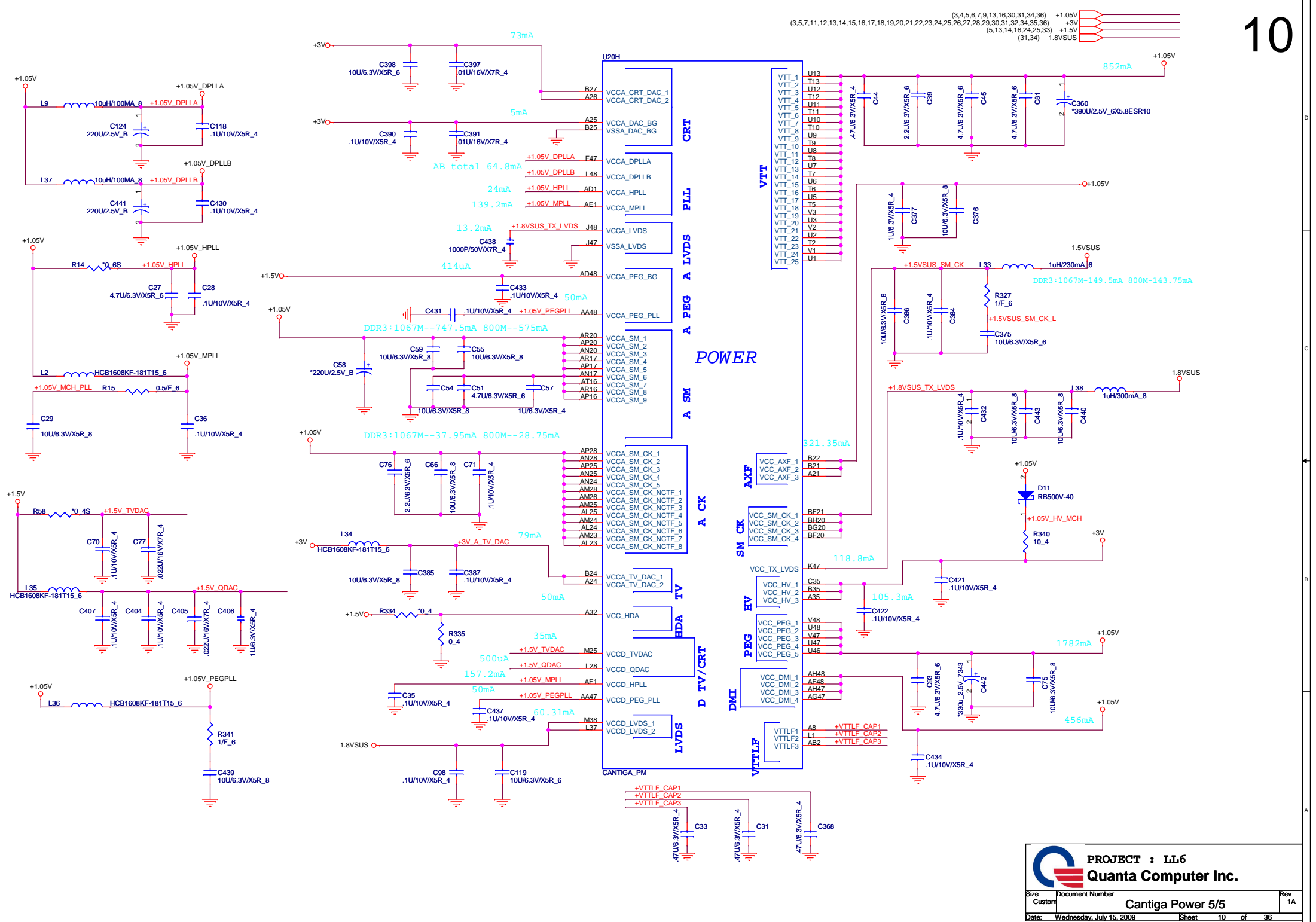

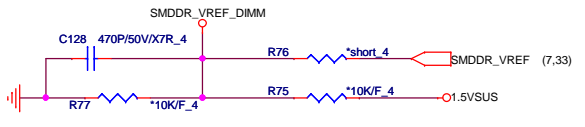
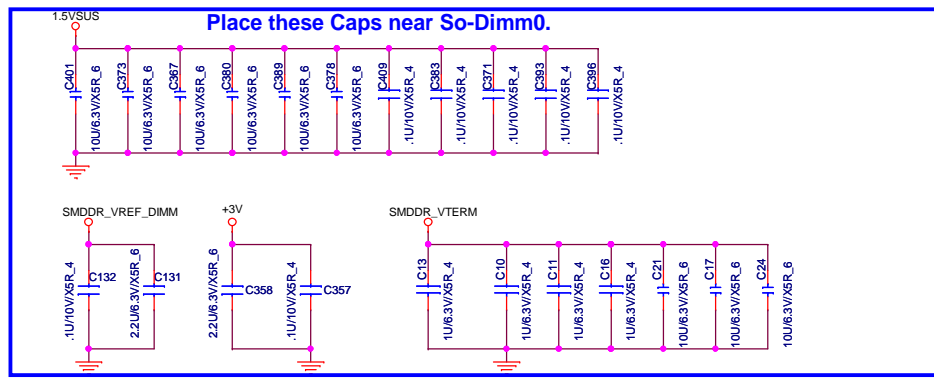
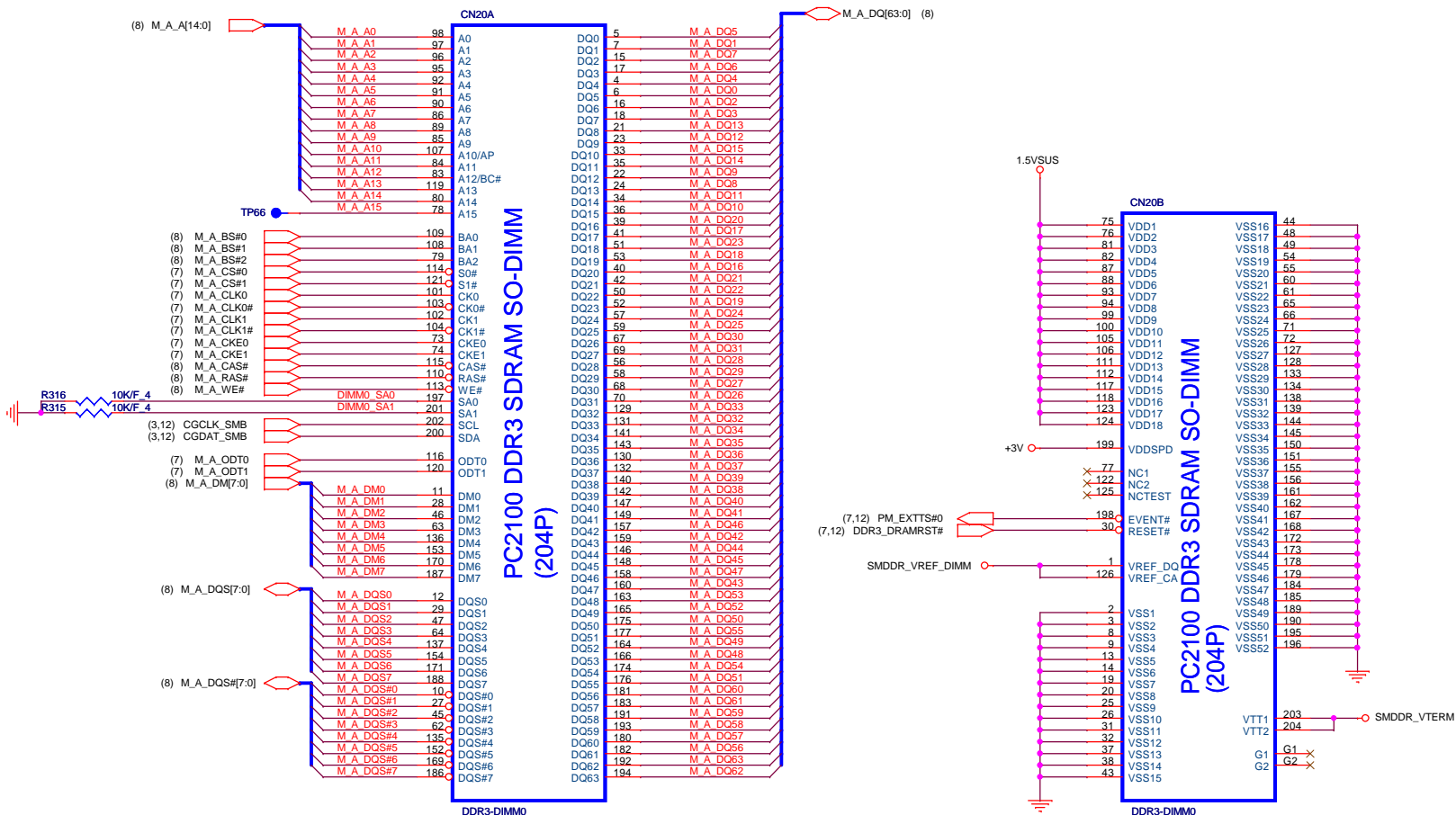

PROJECT : LL6
Quanta Computer Inc.

Size: Custom Document Number: **DDR3 DIMM-0(H=5.2)** Rev: 1A

Date: Wednesday, July 15, 2009 Sheet: 11 of 36

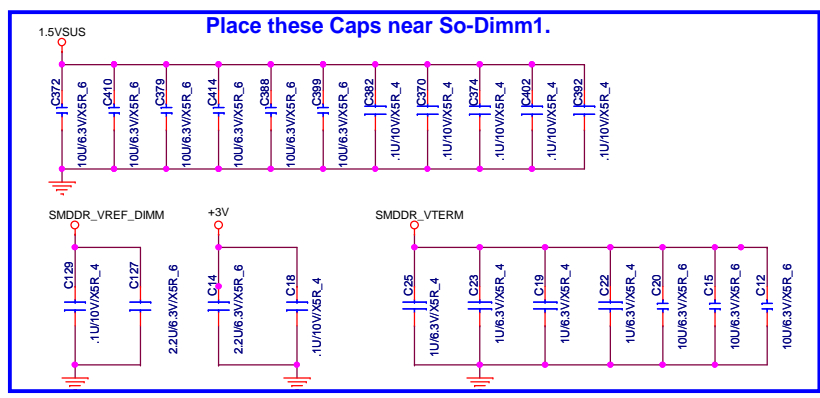
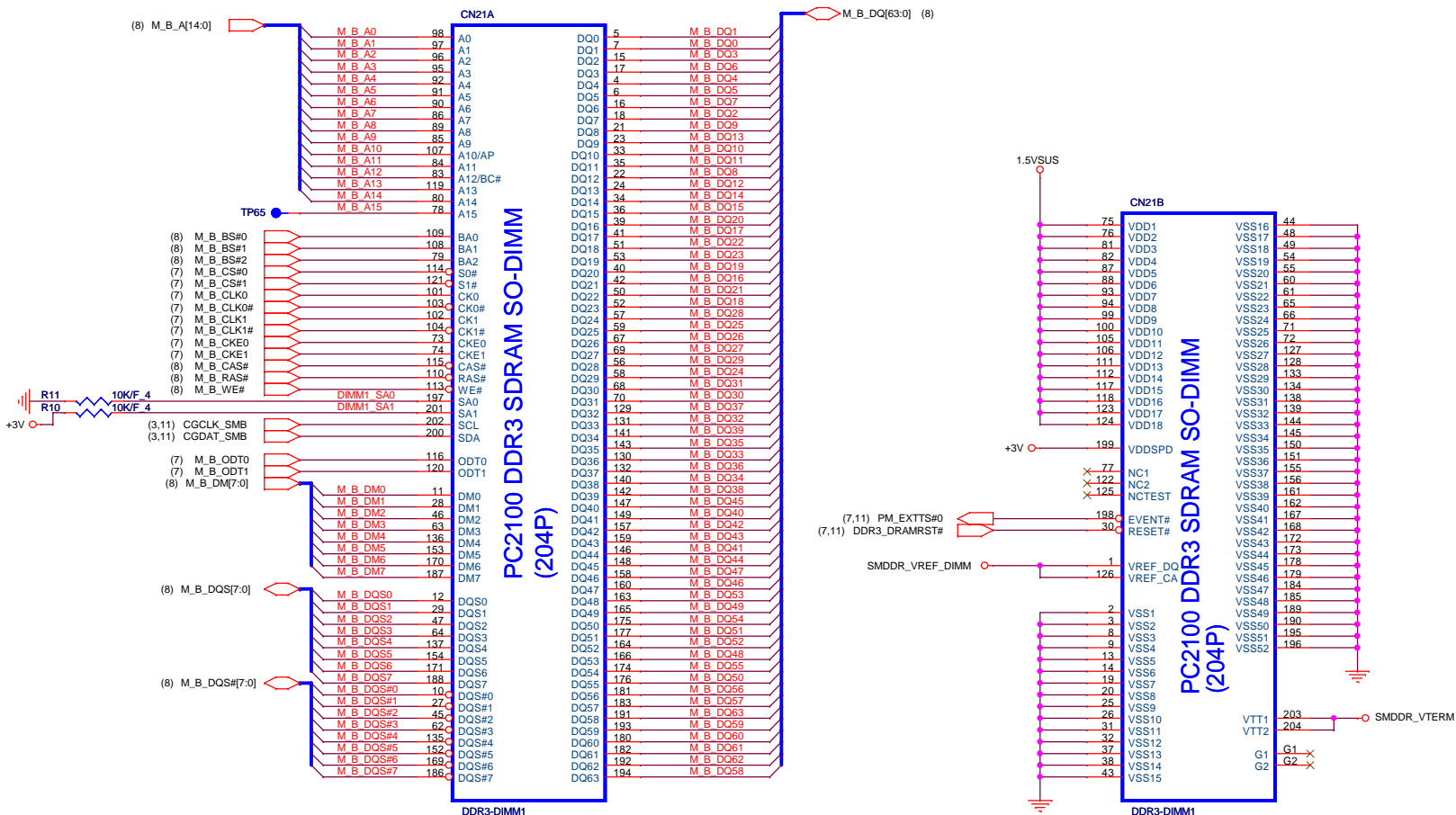

PROJECT : LL6
Quanta Computer Inc.

Size: Custom | Document Number: **DDR3 DIMM-1(H=9.2)** | Rev: 1A

Date: Wednesday, July 15, 2009 | Sheet: 12 of 36

(3,5,7,10,11,12,13,14,16,17,18,19,20,21,22,23,24,25,26,27,28,29,30,31,32,34,35,36) +3V
(13,14,16,31) 3V_S5

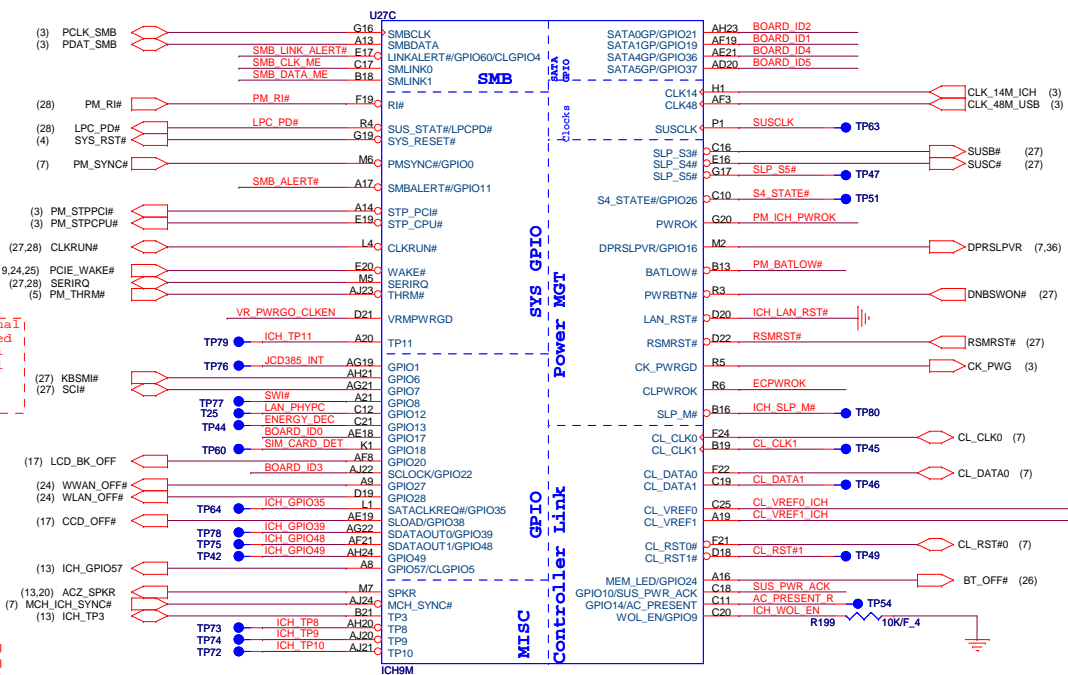

Notice: GPIO20 signal should not be pulled high for functional strap(internal pull down 20k).

Notice: GPIO49 is also a strap pin(internal pull up 20k). Don't pull-down.

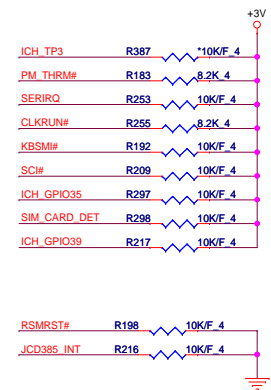
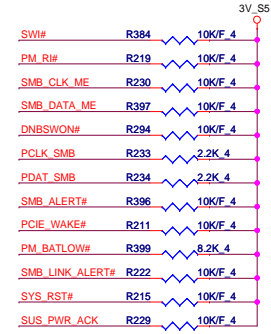

Board ID

Board ID For Function	ID3 GPIO22	ID2 GPIO21	ID1 GPIO19	ID0 GPIO17
Default	0	0	0	0
	0	0	0	1
	0	0	1	0
	0	0	1	1
	0	1	0	0
	0	1	0	1
	0	1	1	0
	0	1	1	1
	1	0	0	0
	1	0	0	1
	1	0	1	0
	1	0	1	1
	1	1	0	0
	1	1	0	1
	1	1	1	0
	1	1	1	1

Board ID For Model	ID5 GPIO37	ID4 GPIO36
	0	0
	0	1
	1	0
	1	1

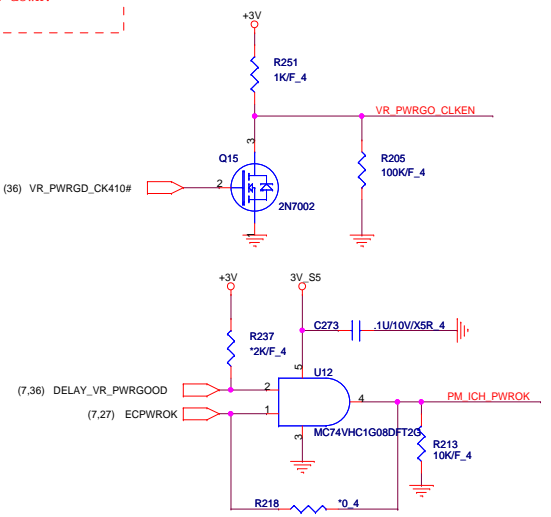

LCD panel control & connector

LCDVCC

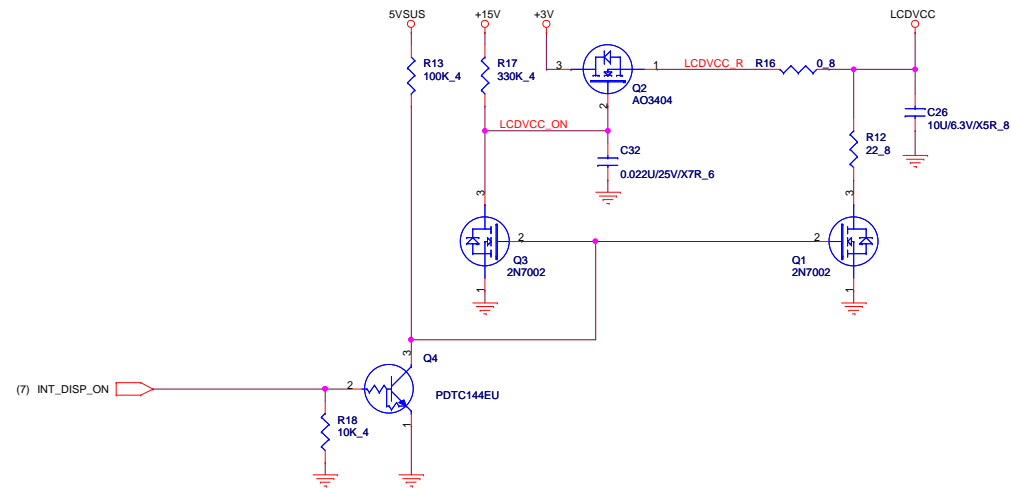

back light

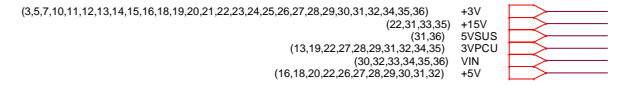
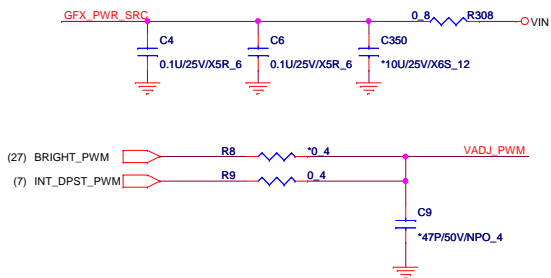
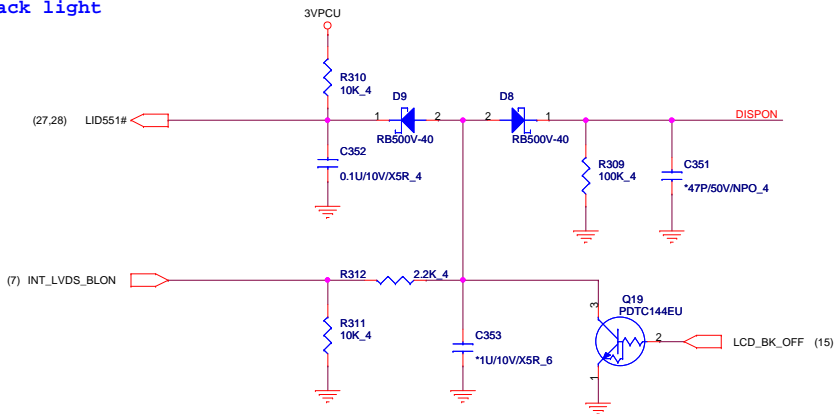

17

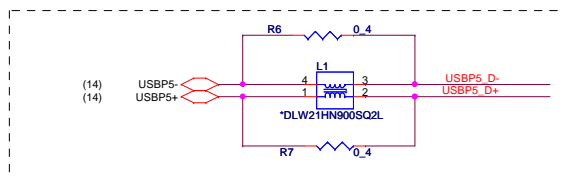
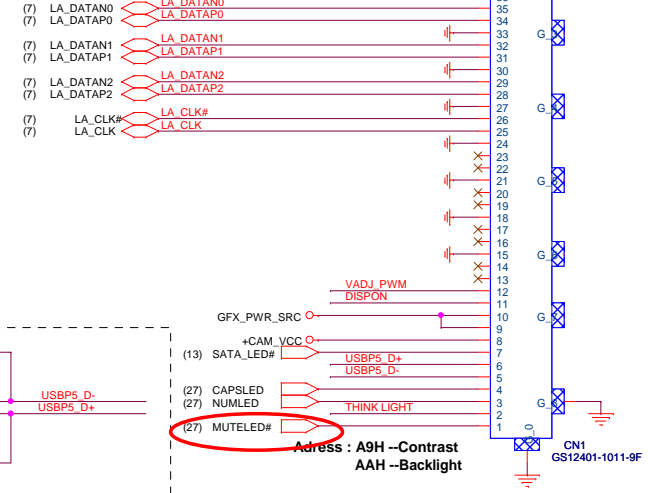
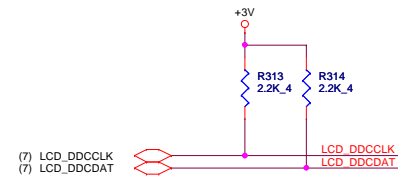

THINK LIGHT LED ON

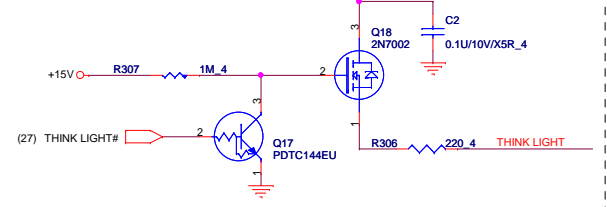

CAMERA VCC Control

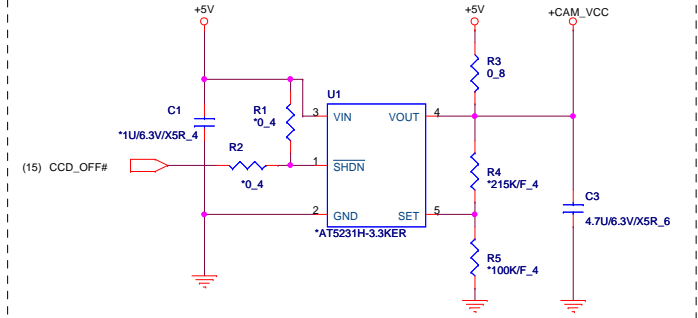

CRT PORT

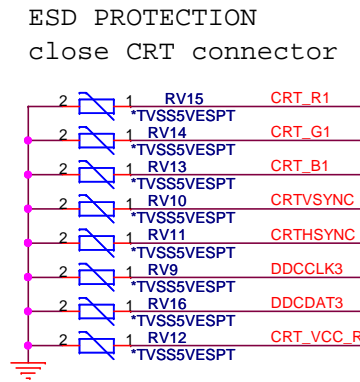
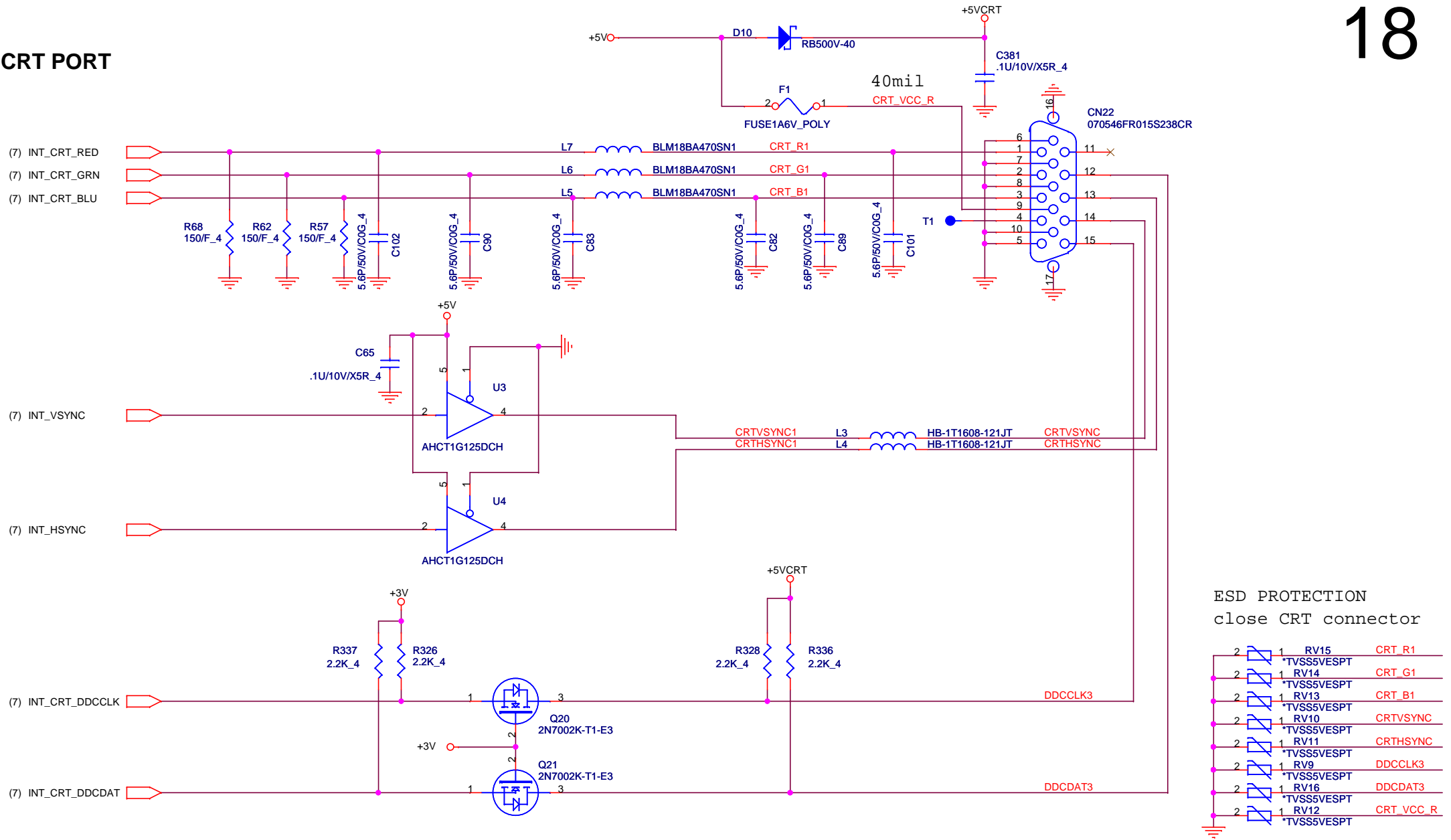

PROJECT : LL6
Quanta Computer Inc.

Size: Custom Document Number: CRT CON Rev: 1A

Date: Wednesday, July 15, 2009 Sheet: 18 of 36

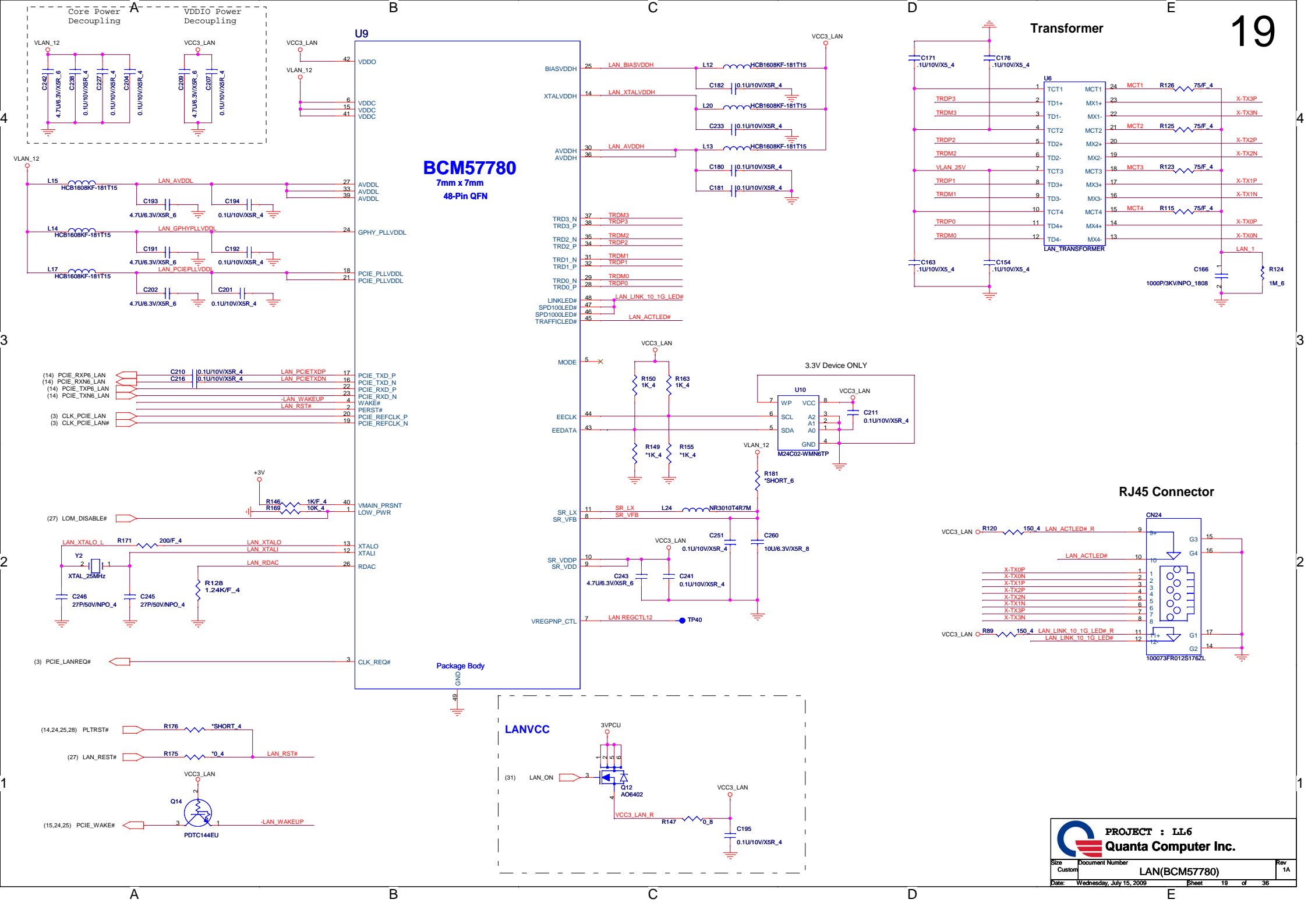

BCM57780
7mm x 7mm
48-Pin QFN

Package Body

LANVCC

Transformer

RJ45 Connector

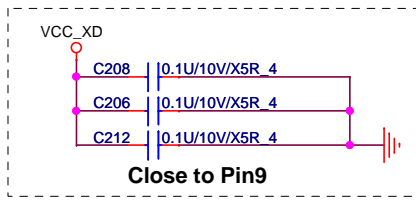
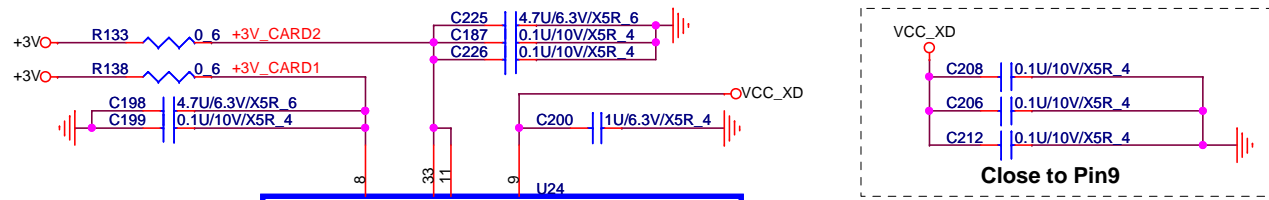

Note:

	SD/MMC	MS	XD
SP0			
SP1			XD_CD#
SP2	SD_WP		
SP3	SD_CD#		
SP4	SD_DAT1		XD_D4
SP5		MS_BS	XD_D5
SP6		MS_D1	XD_D3
SP7	SD_DAT0	MS_D0	XD_D6
SP8	SD_DAT7	MS_D2	XD_D2
SP9		MS_INS#	
SP10	SD_DAT6	MS_D3	XD_D7
SP11	SD_CLK	MS_SCLK	XD_D1
SP12	SD_DAT5		XD_D0
SP13	SD_DAT4		XD_WP#
SP14			XD_R/B#
SP15	SD_DAT3		XD_WE#
SP16	SD_DAT2		XD_RE#
SP17			XD_ALE
SP18			XD_CE#
SP19			XD_CLE

For external 12Mhz clock input pin13 floating
For external 48Mhz clock input pin13 pull high

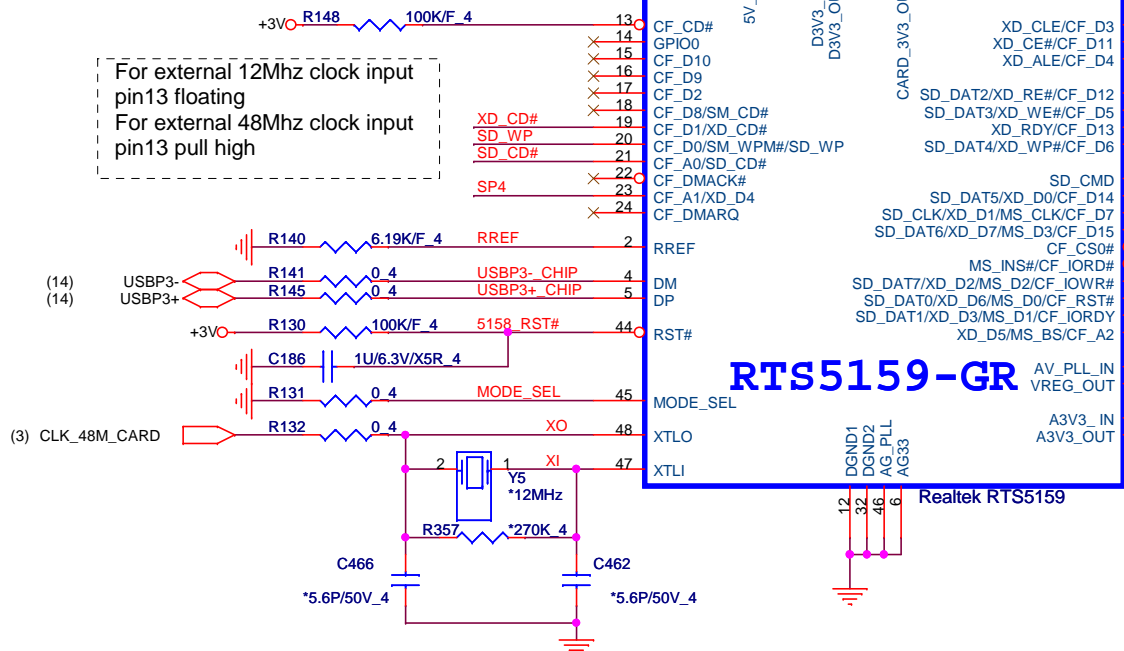

RTS5159-GR

Realtek RTS5159

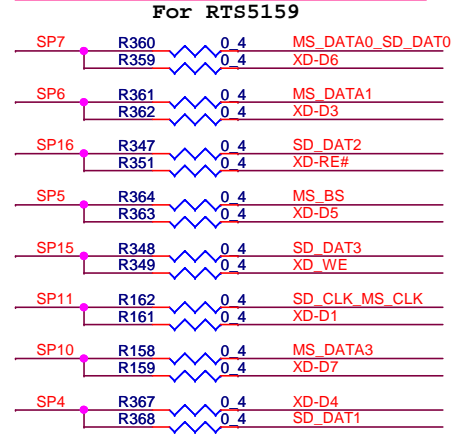

5 IN1 CARD READER XD, MMC/SD, MS/MSP

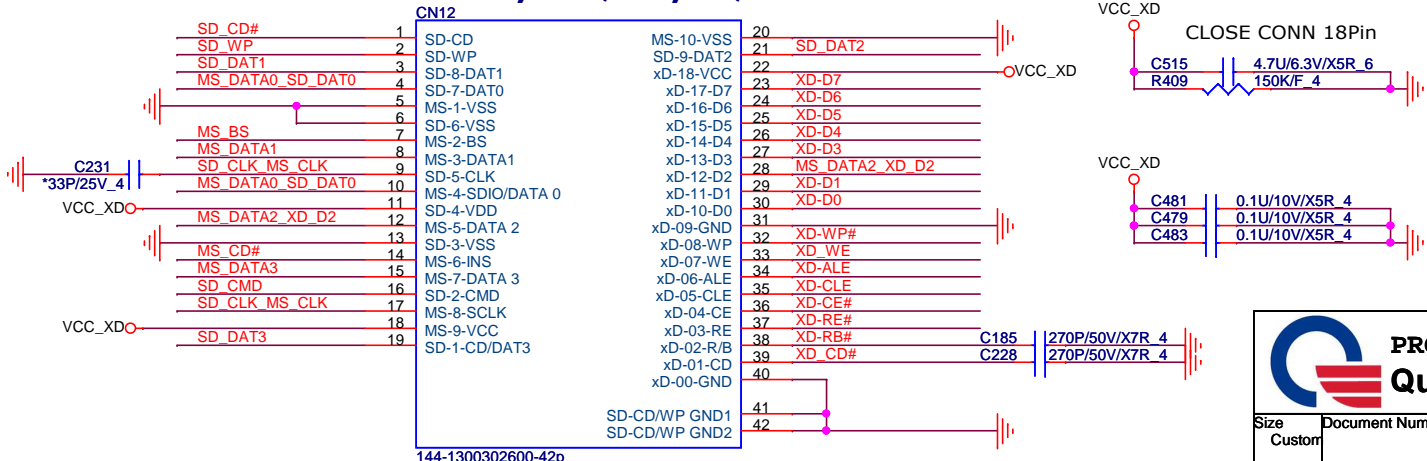

PROJECT : LL6
Quanta Computer Inc.

Size	Document Number	Rev
Custom	Card Reader (RTS5159)	1A
Date:	Wednesday, July 15, 2009	Sheet 21 of 36

144-1300302600-42p

SATA-HDD

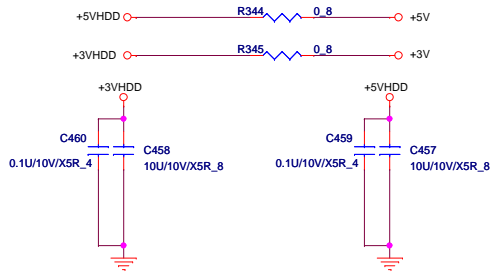
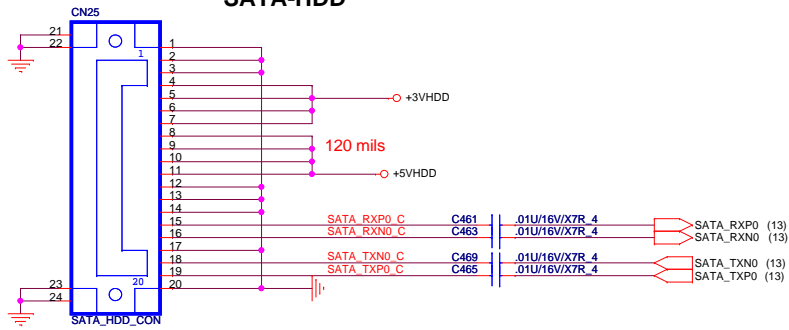

SATA ODD

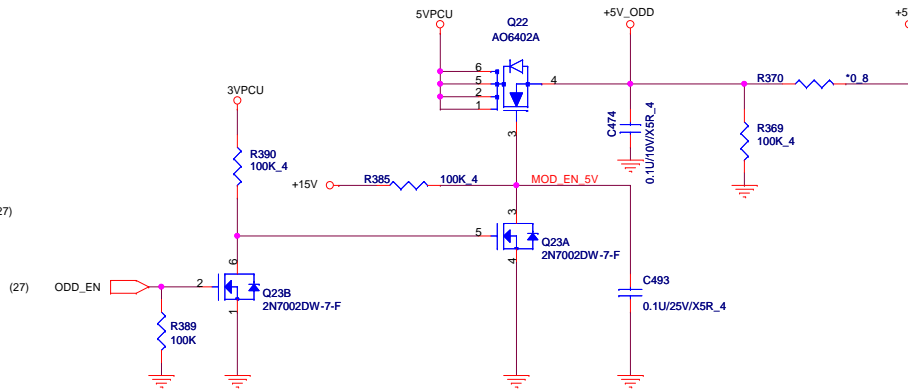
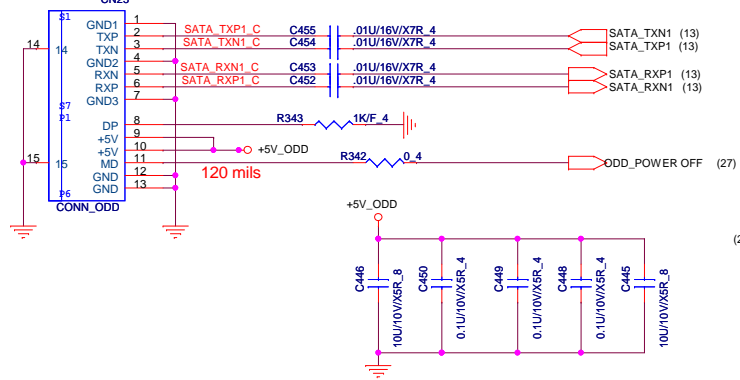

		PROJECT : LL6	
		Quanta Computer Inc.	
Size Custom	Document Number	SATA HDD/ ODD/ eSATA/USB	
Date: Wednesday, July 15, 2009	Sheet	22	of 36
			Rev 1A

USB 1

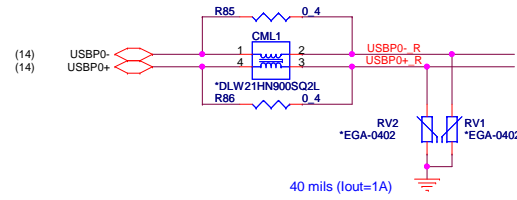
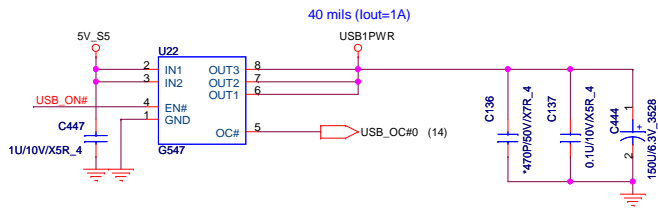

E-SATA RE-DRIVER

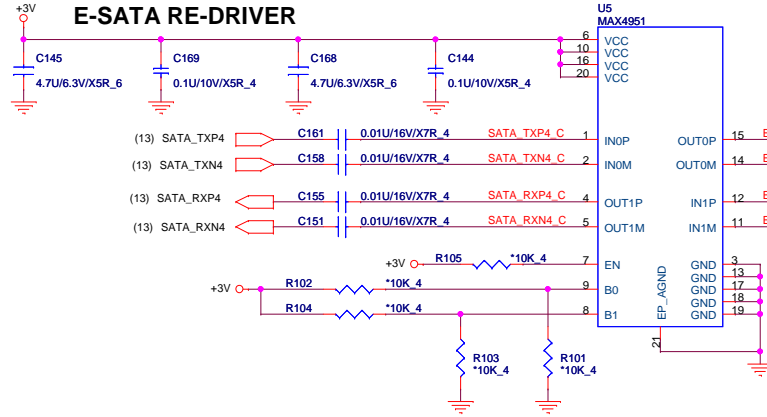

EN	B0	B1	FUNCTION
0	X	X	Standby
1	0	0	Standard SATA Output
1	1	0	Ch 0 Boost Output
1	0	1	Ch 1 Boost Output
1	1	1	Ch 0,1 Boost Output

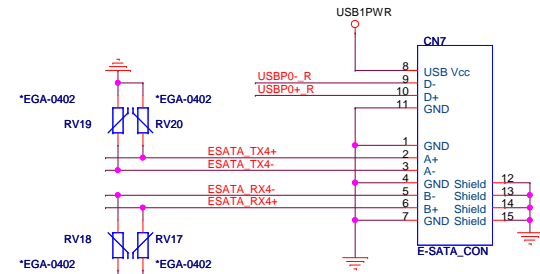

USB 2

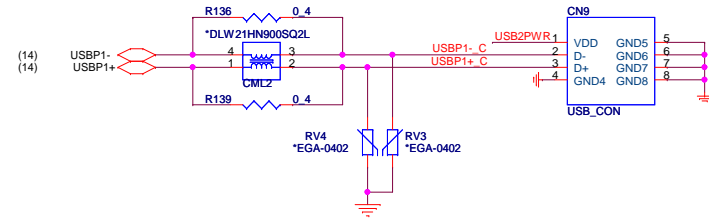
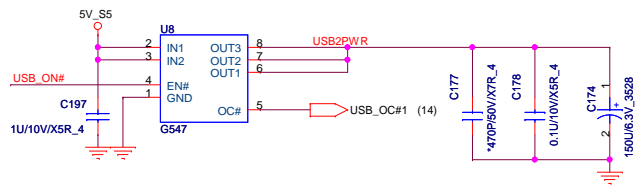

USB 3

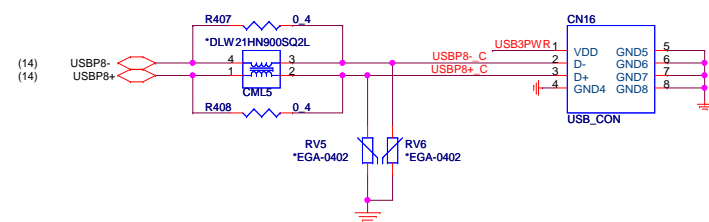
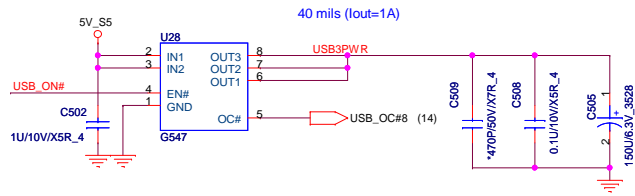

USB 4

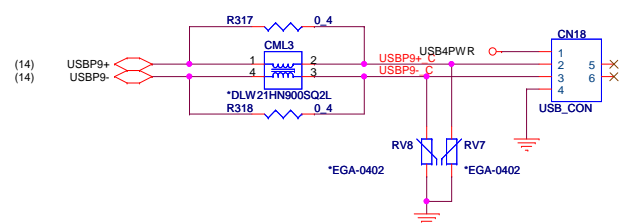
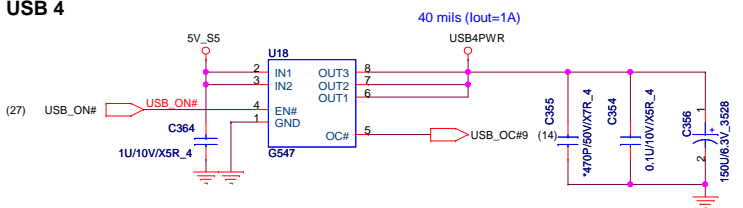

PROJECT : LL6
Quanta Computer Inc.

Size Custom	Document Number USB X4/eSATA PORT	Rev 1A
Date: Wednesday, July 15, 2009	Sheet 23 of 36	

Mini PCI-E Card (WLAN/ WIMAX)

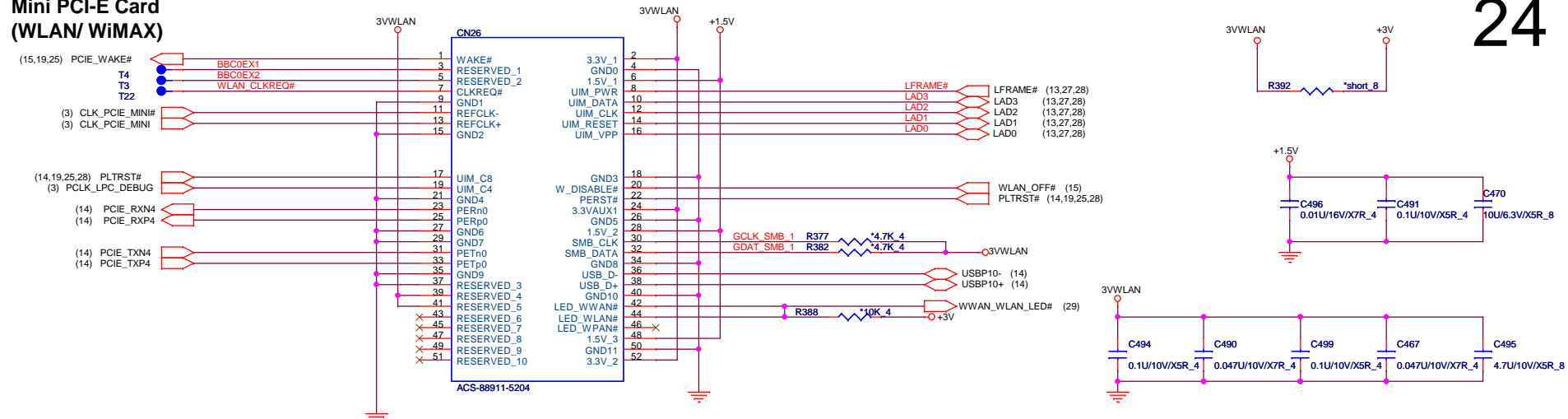

24

Mini PCI-E Card WWAN(Robson)

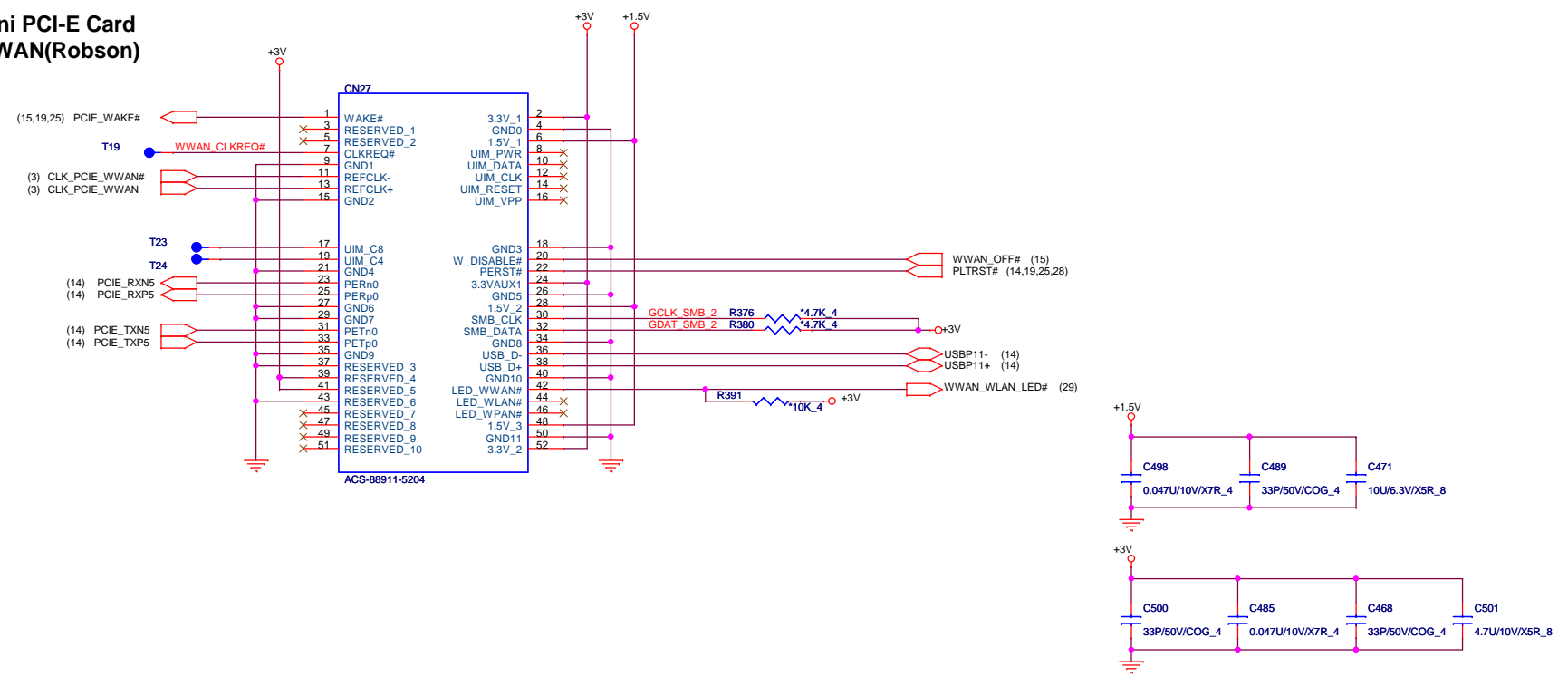

PROJECT : LL6
Quanta Computer Inc.

Size: Custom	Document Number: WLAN & WWAN Slot	Rev: 1A
Date: Wednesday, July 15, 2009	Sheet: 24	of 36

PCI Express Card

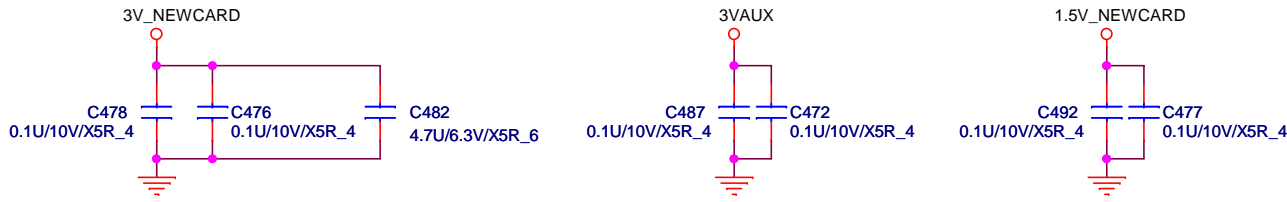
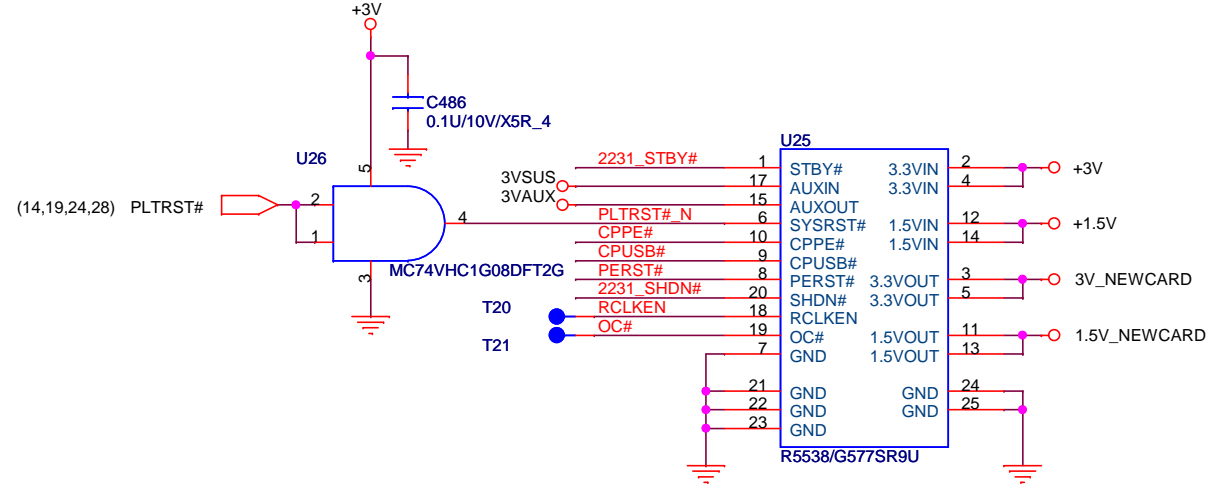
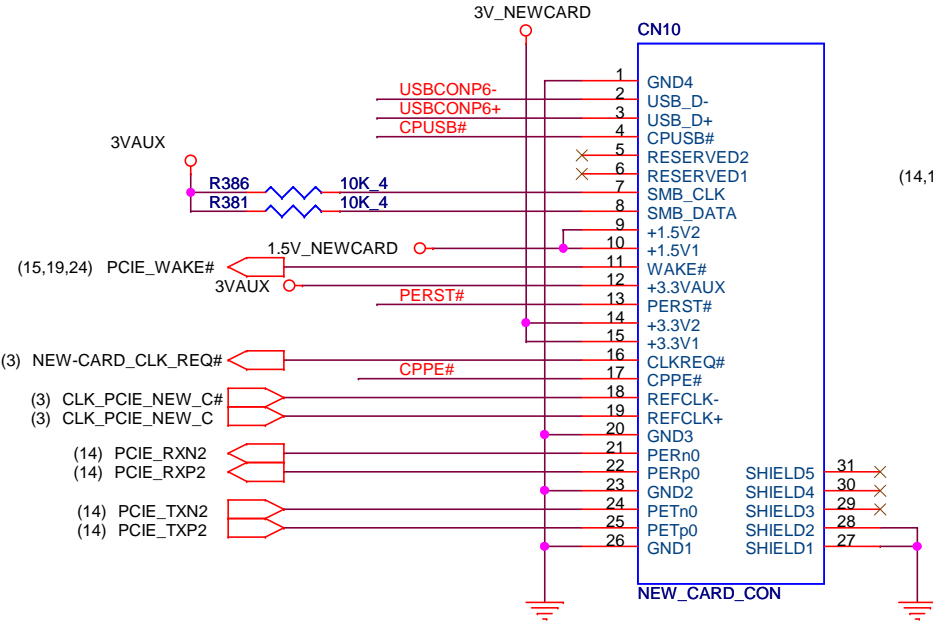
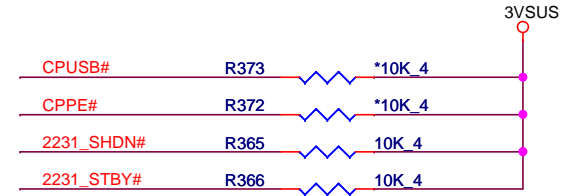
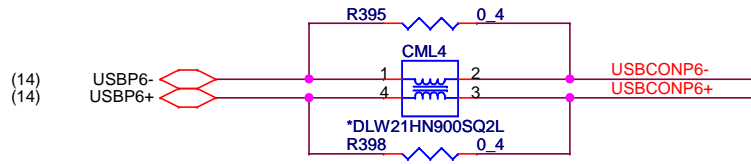

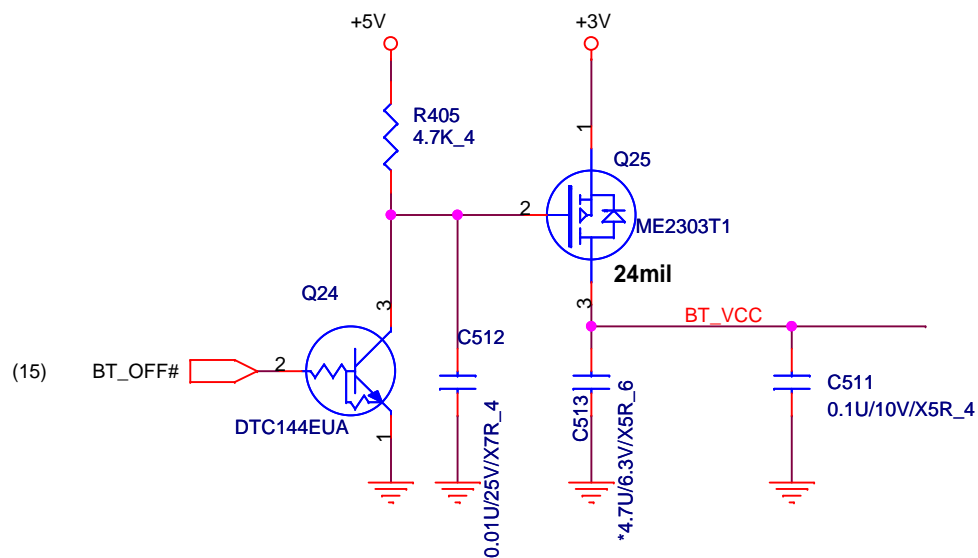
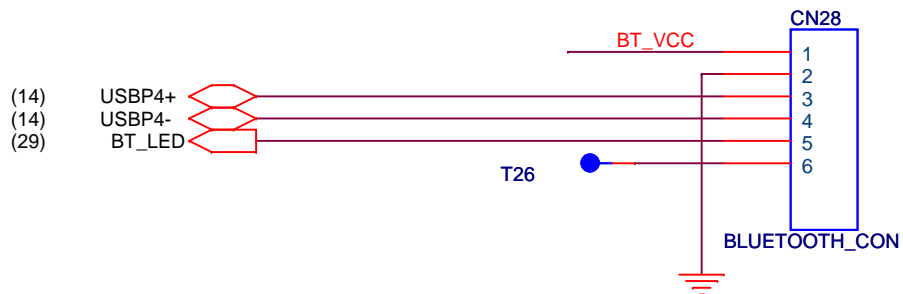

		PROJECT : LL6 Quanta Computer Inc.
Size Custom	Document Number PCI Express Card	Rev 1A
Date: Wednesday, July 15, 2009	Sheet 25 of 36	

BLUETOOTH

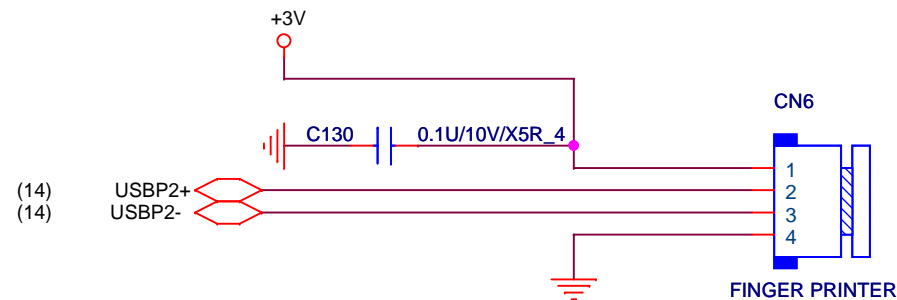

FINGER PRINTER



		PROJECT : LL6 Quanta Computer Inc.	
Size Custom	Document Number Buletooth / FP Conn		Rev 1A
Date:	Wednesday, July 15, 2009	Sheet	26 of 36

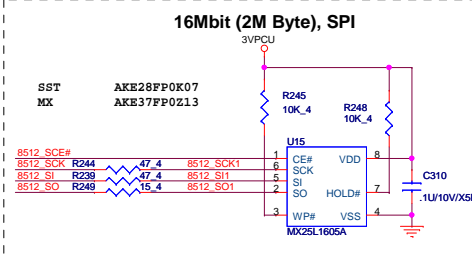
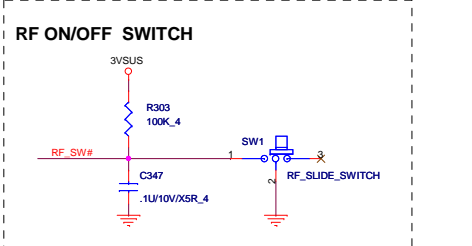
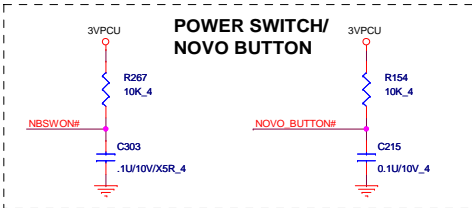
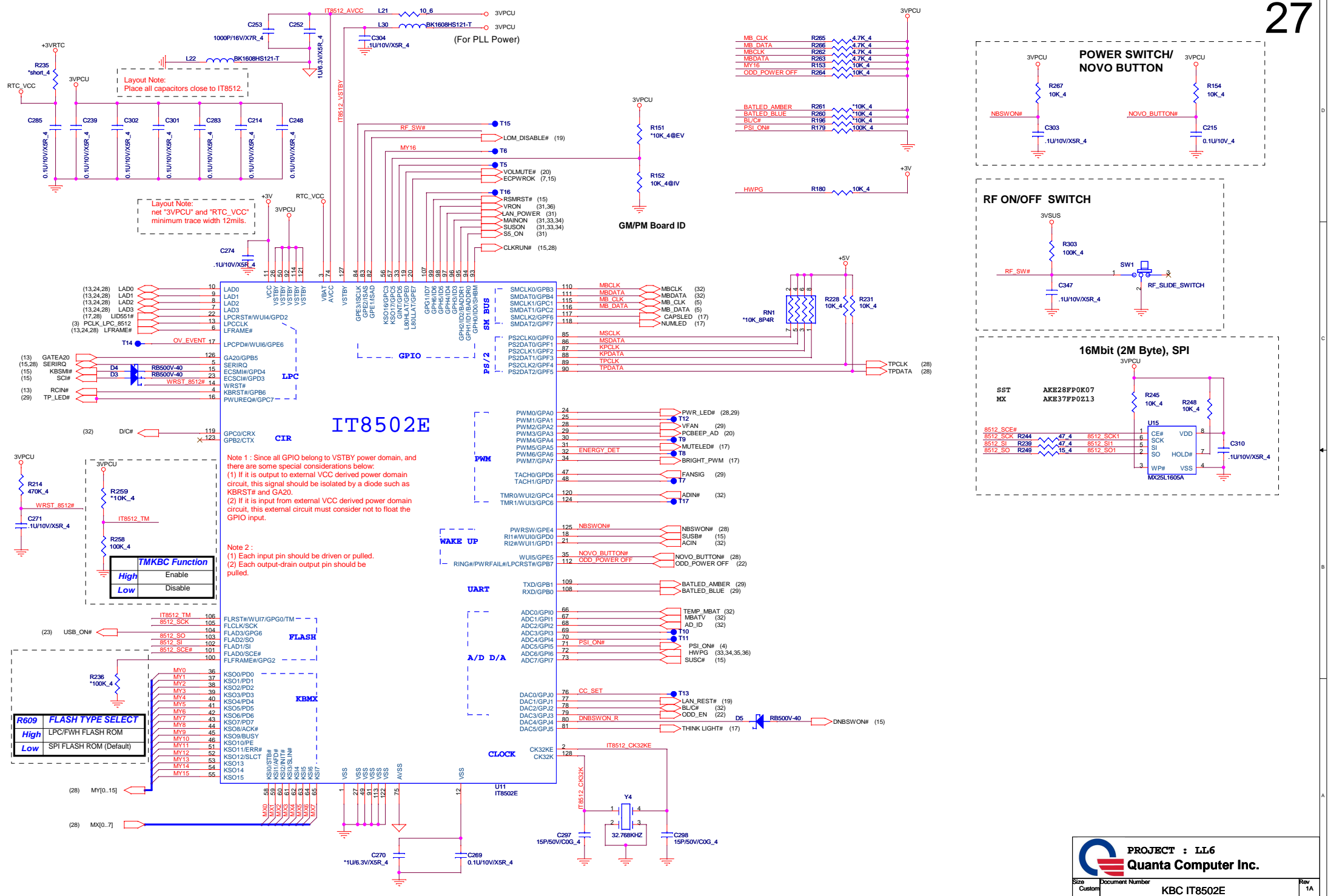

IT8502E

Note 1 : Since all GPIO belong to VSTBY power domain, and there are some special considerations below:
 (1) If it is output to external VCC derived power domain circuit, this signal should be isolated by a diode such as KBRST# and GA20.
 (2) If it is input from external VCC derived power domain circuit, this external circuit must consider not to float the GPIO input.

Note 2 :
 (1) Each input pin should be driven or pulled.
 (2) Each output-drain output pin should be pulled.

TMKBC Function	
High	Enable
Low	Disable

FLASH TYPE SELECT	
High	LPC/FWH FLASH ROM
Low	SPI FLASH ROM (Default)

KEYBOARD

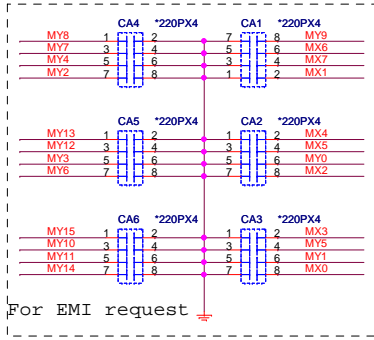
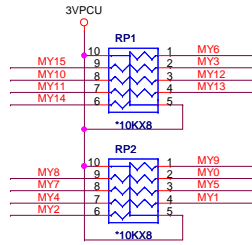
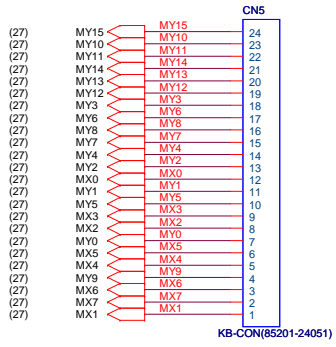

For EMI request

FUNCTION BUTTON BOARD

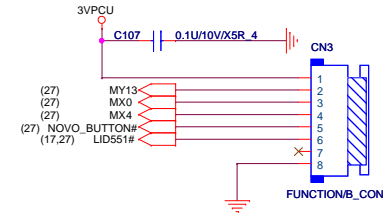

TOUCH PAD

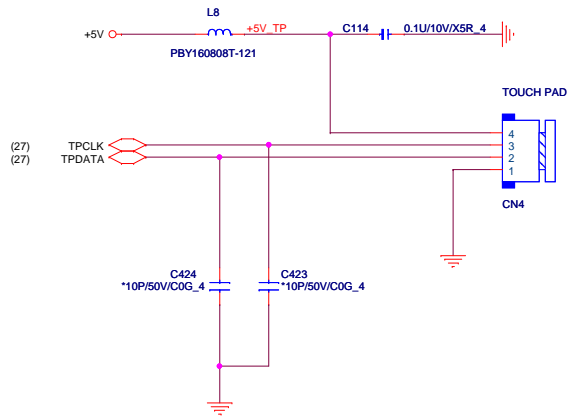

POWER BUTTON BOARD

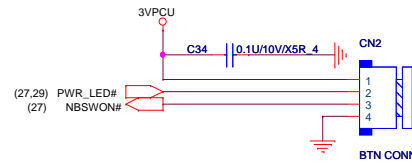

SIO BOARD

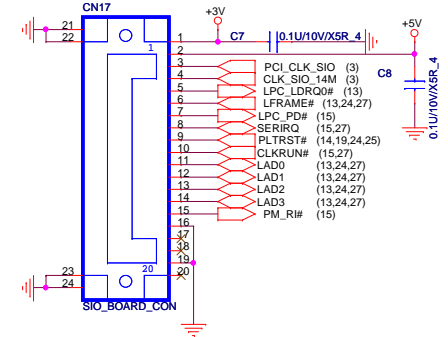

PROJECT : LL6
Quanta Computer Inc.

Size	Document Number	Rev
Custom	KB/TP/PW-B/FN-B	1A
Date:	Wednesday, July 15, 2009	Sheet 28 of 36

LED

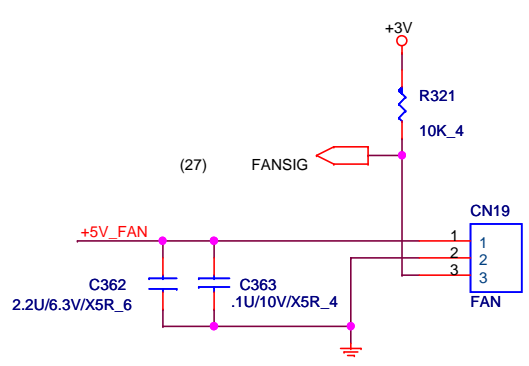
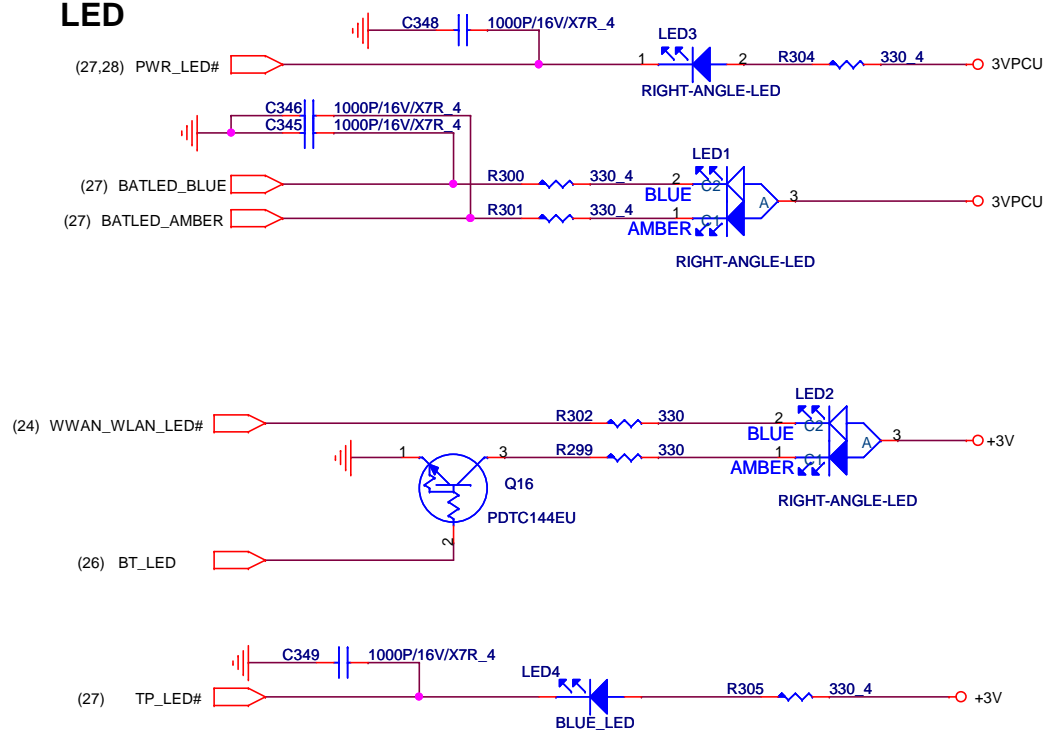

FAN Controller

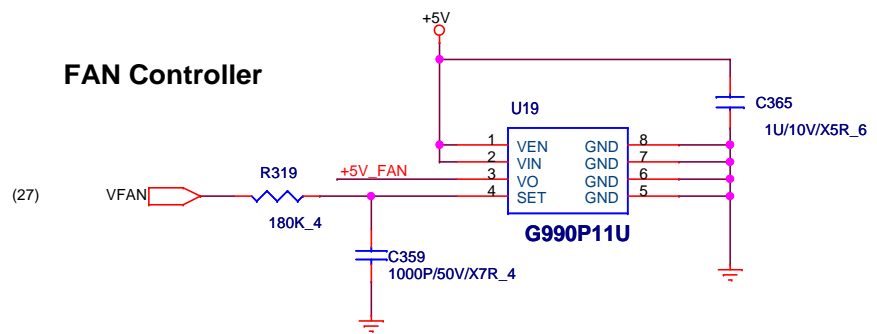

 PROJECT : LL6 Quanta Computer Inc.		
Size Custom	Document Number LED/FAN	Rev 1A
Date: Wednesday, July 15, 2009	Sheet 29 of 36	

Hole for CPU support

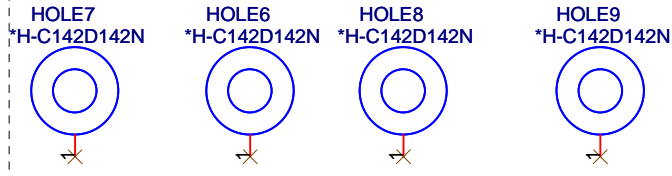

North Bridge nut

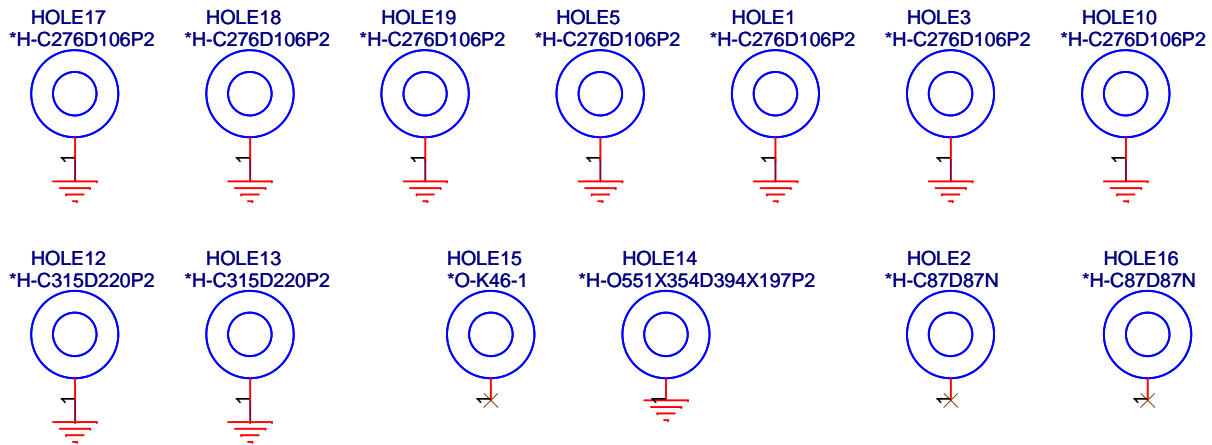
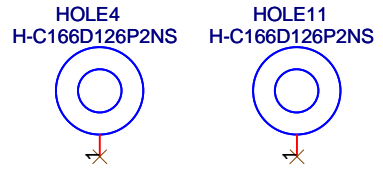

WWAN nut

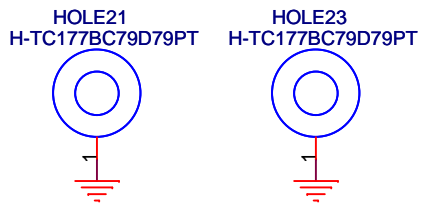

WLAN nut

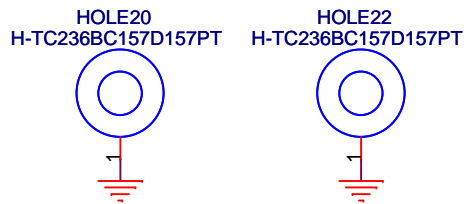

For EMI

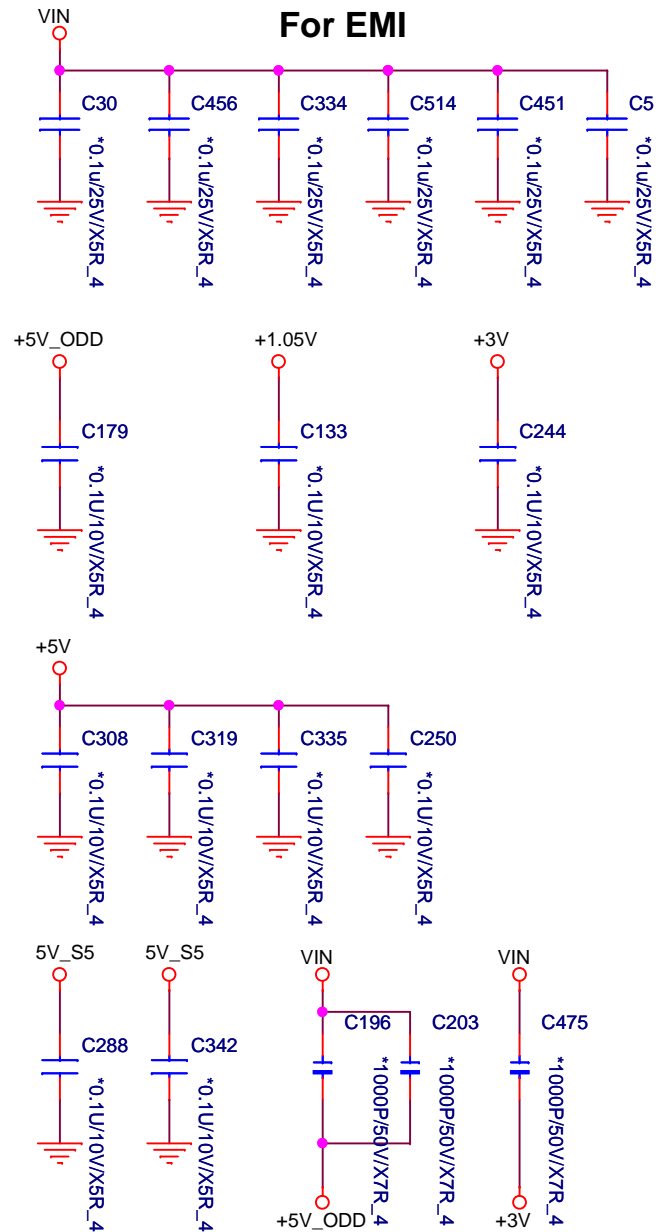

PROJECT : LL6
Quanta Computer Inc.

Size A	Document Number KB/TP/FAN/SCREW HOLE	Rev 1A
Date: Wednesday, July 15, 2009	Sheet 30	of 36

+3V, +5V

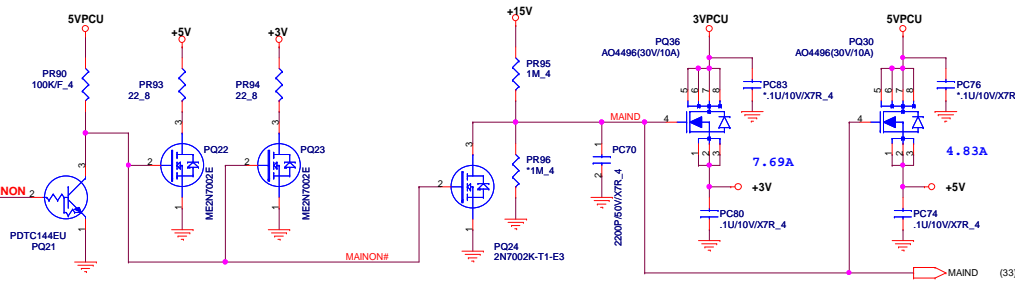

+1.05V, SMDDR_VTERM

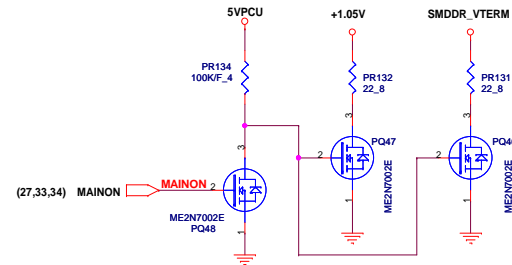

3V_S5, 5V_S5

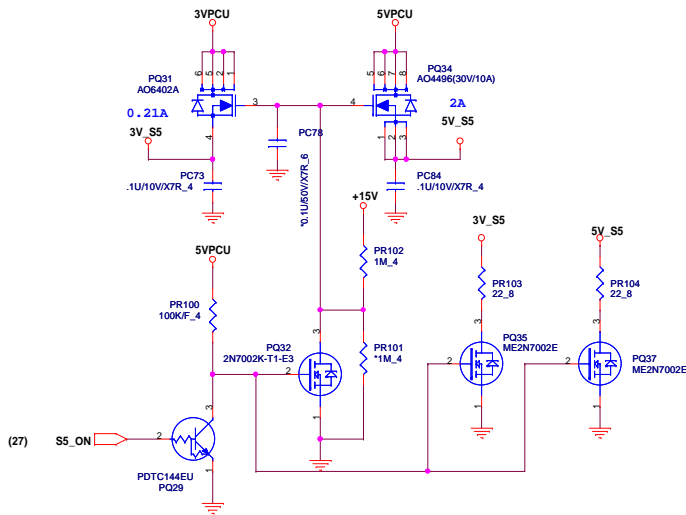

LANVCC

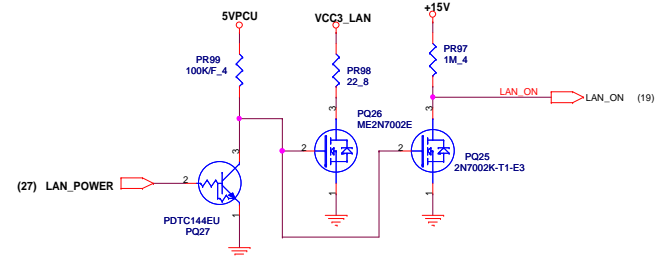

VCC_CORE

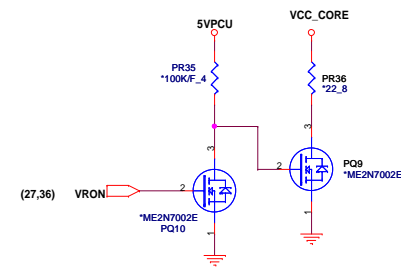

3VSUS, 5VSUS, 1.5VSUS, 1.8VSUS

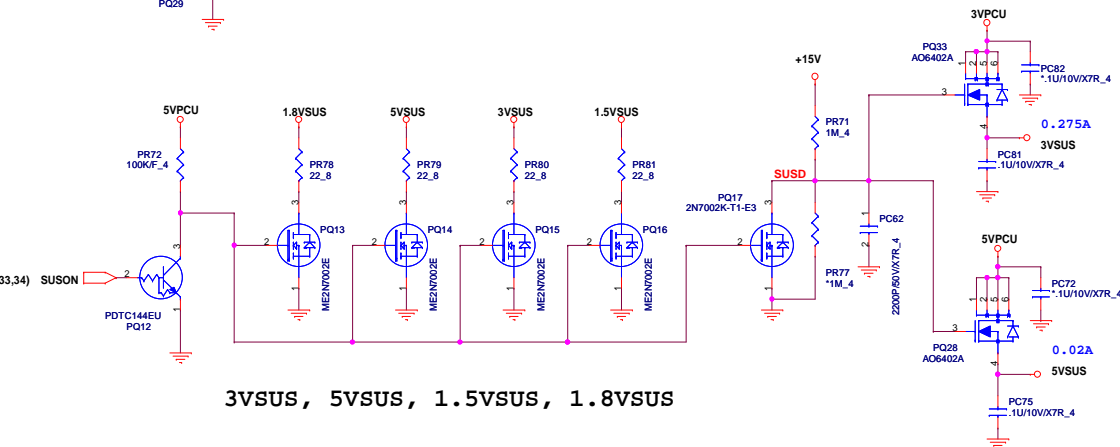

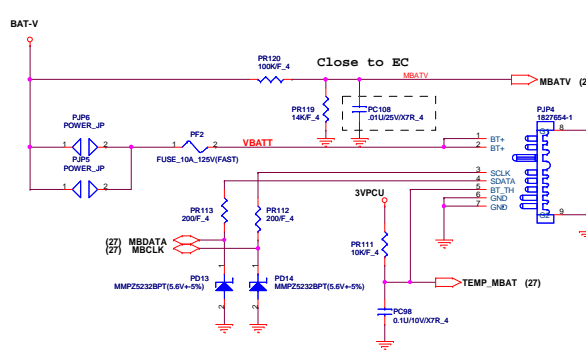
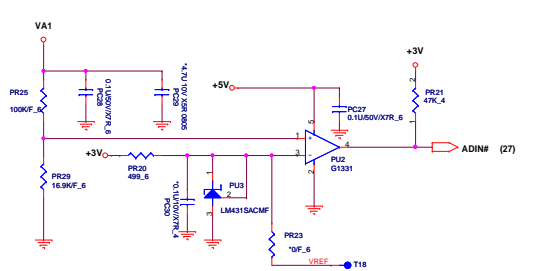
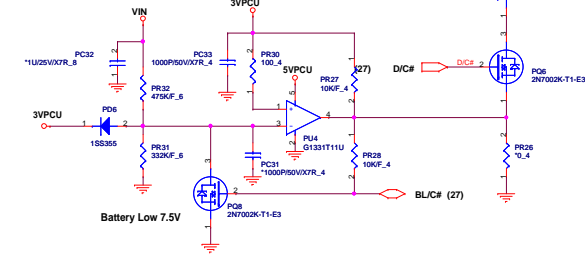
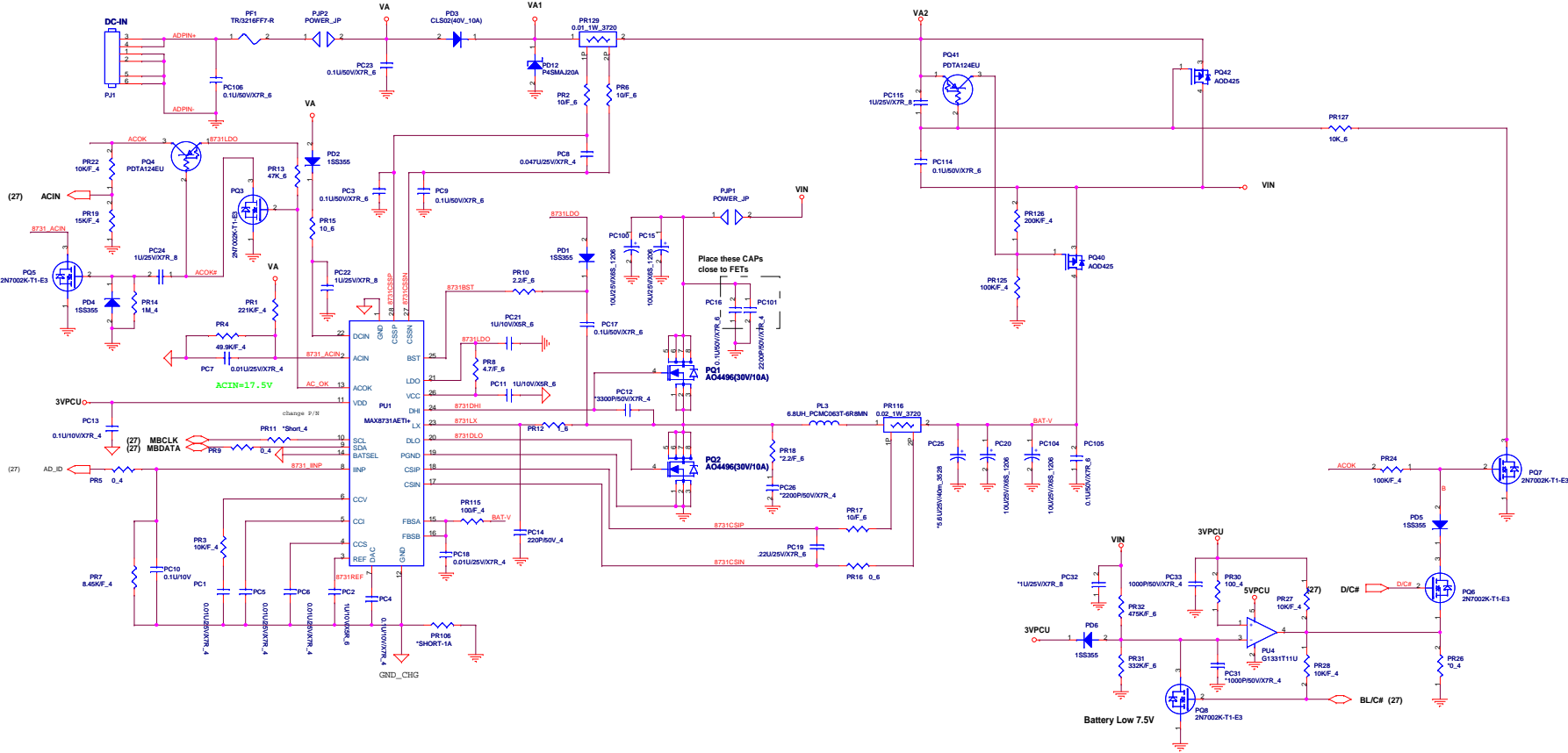

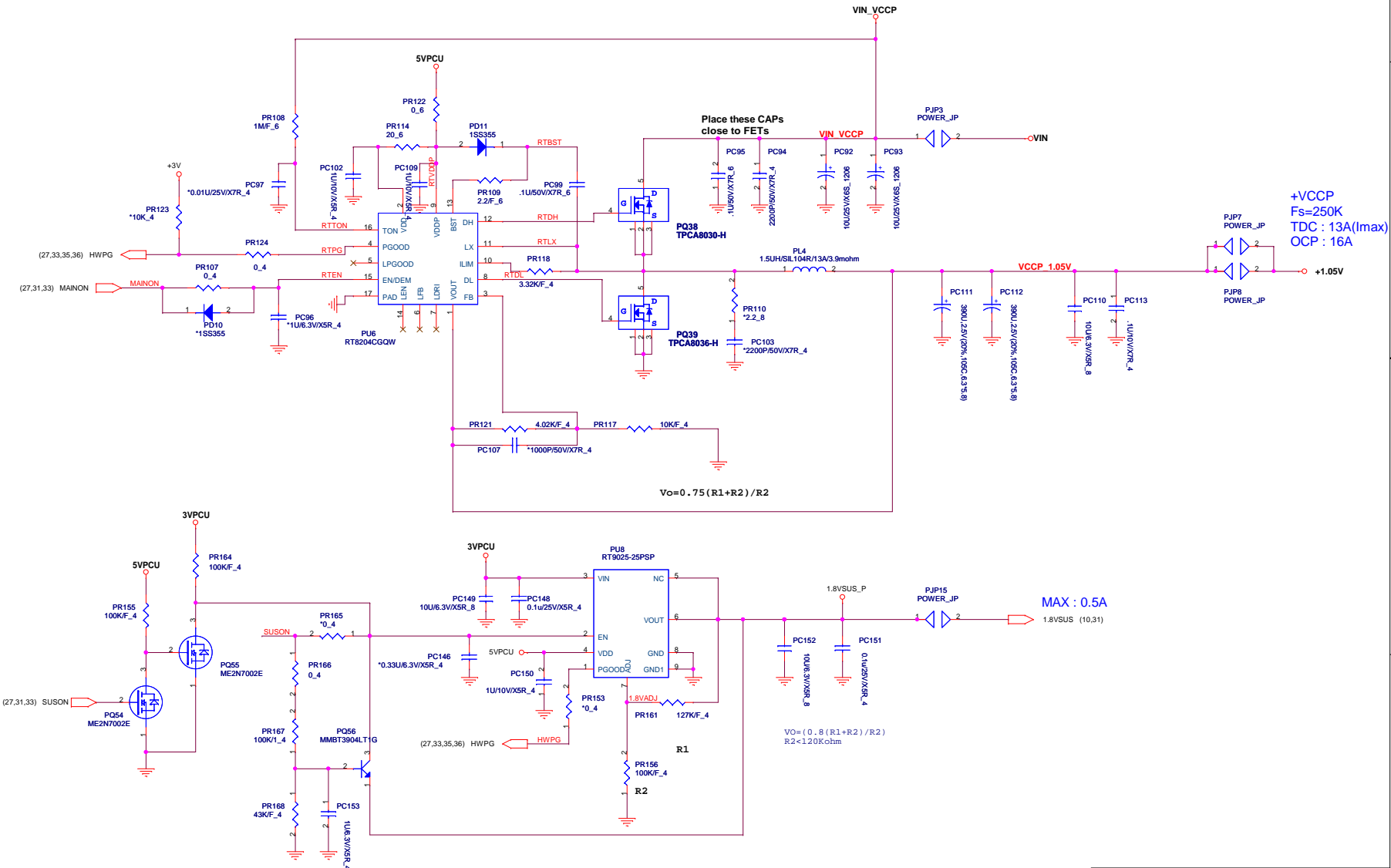

(13,17,19,22,27,28,29,31,32,34) 3VPCU
 (13,22,31,32,33,34,36) 5VPCU
 (17,22,31,33) +15V
 (17,30,32,33,34,36) VIN

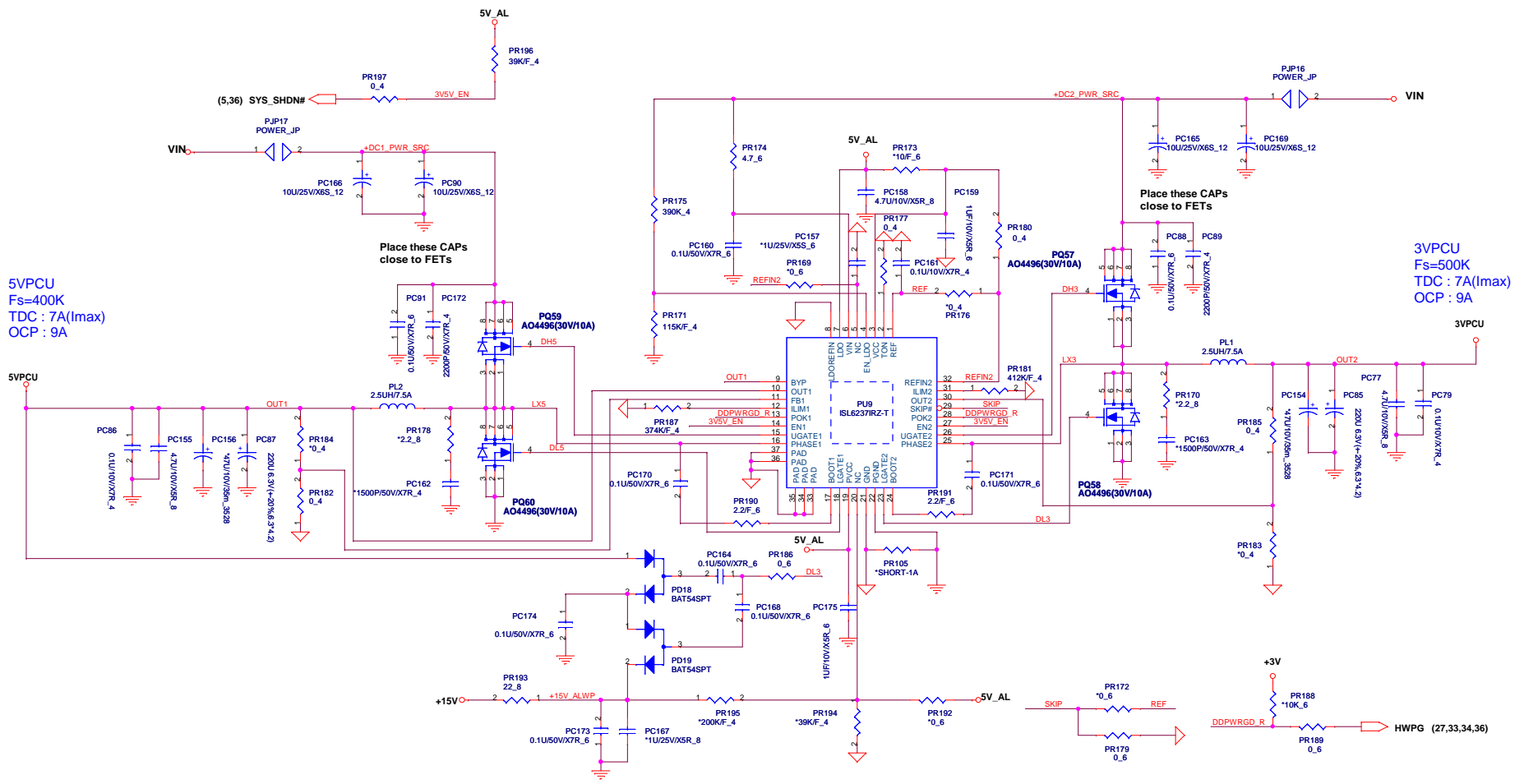

5VPCU
 Fs=400K
 TDC : 7A(Imax)
 OCP : 9A

3VPCU
 Fs=500K
 TDC : 7A(Imax)
 OCP : 9A

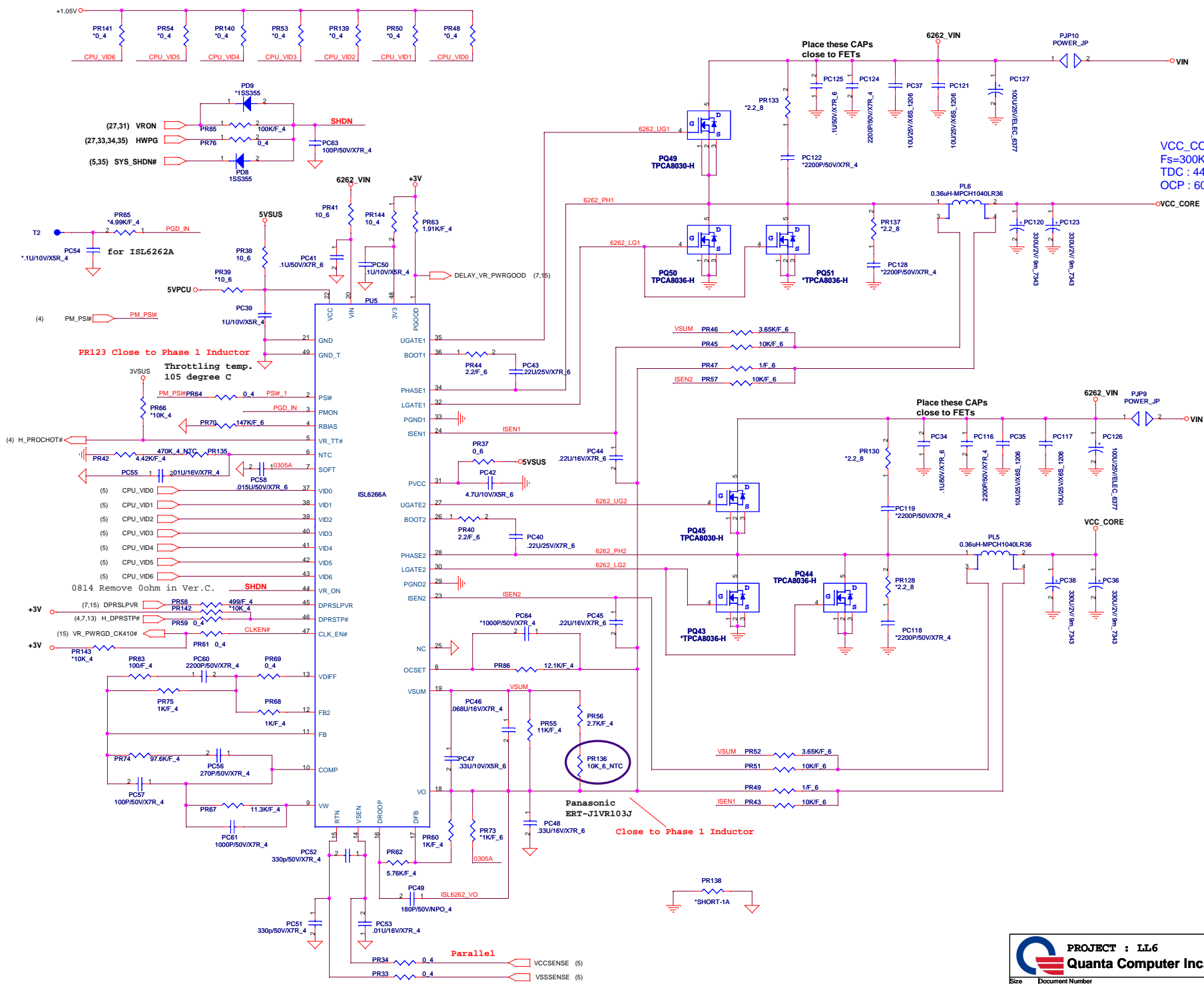

VCC_CORE
 Fs=300K
 TDC : 44A(I_{max})
 OCP : 60A

Panasonic
 ERT-J1VR103J
 Close to Phase 1 Inductor

Place these CAPS
 close to FETS

PR123 Close to Phase 1 Inductor
 Throttling temp.
 105 degree C

Place these CAPS
 close to FETS