

LD-Note Intel Calpella Platform with UMA GFX

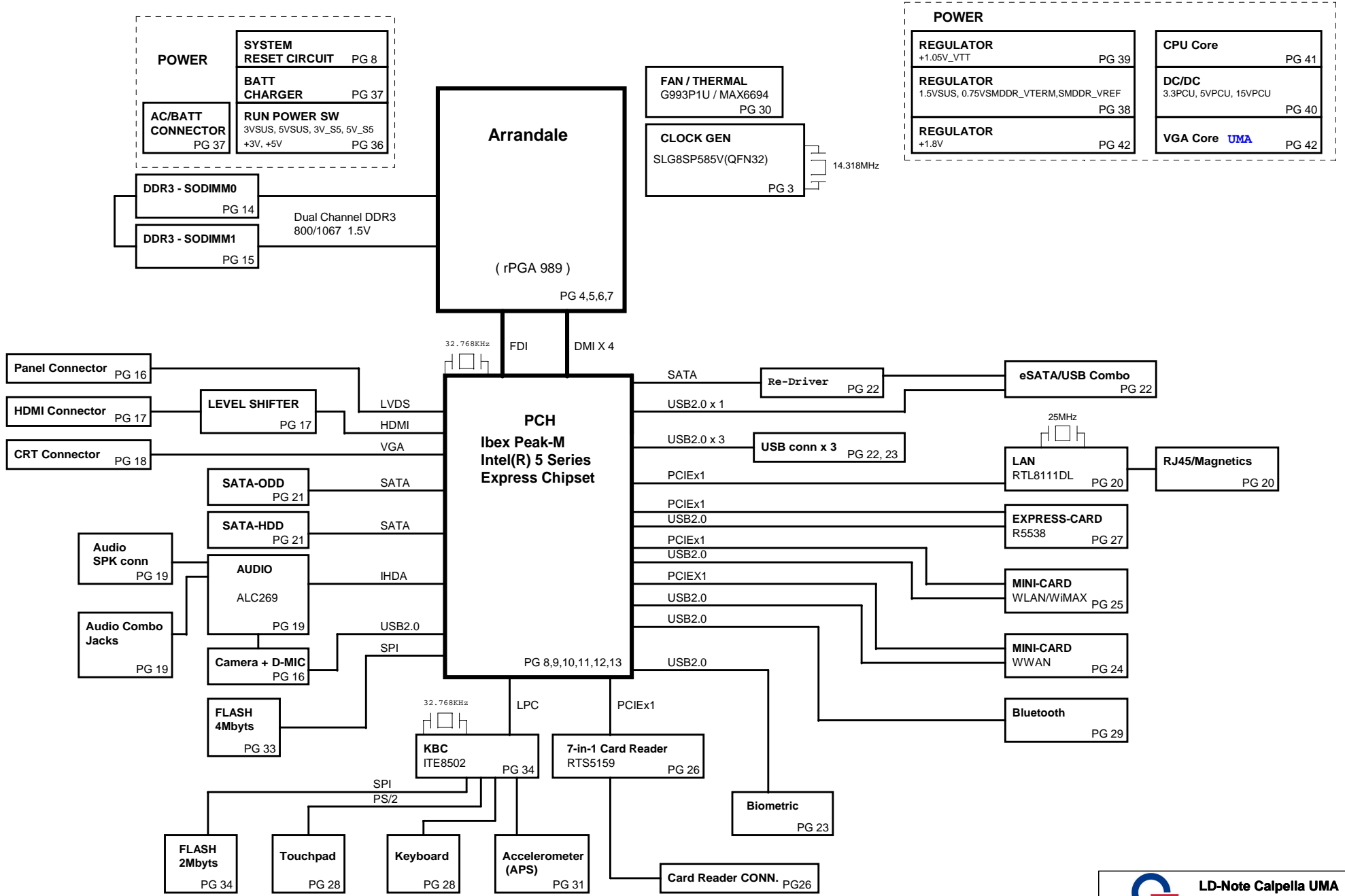
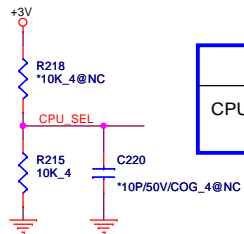
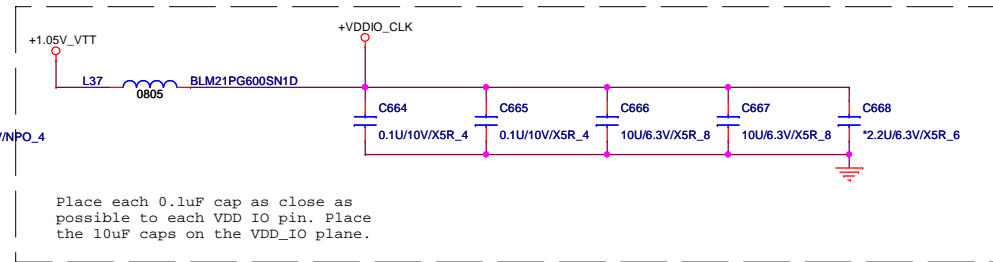
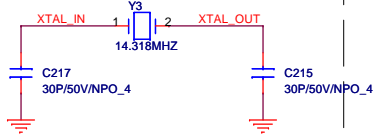
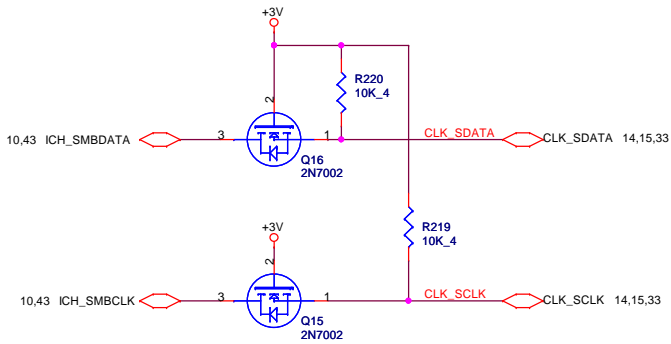
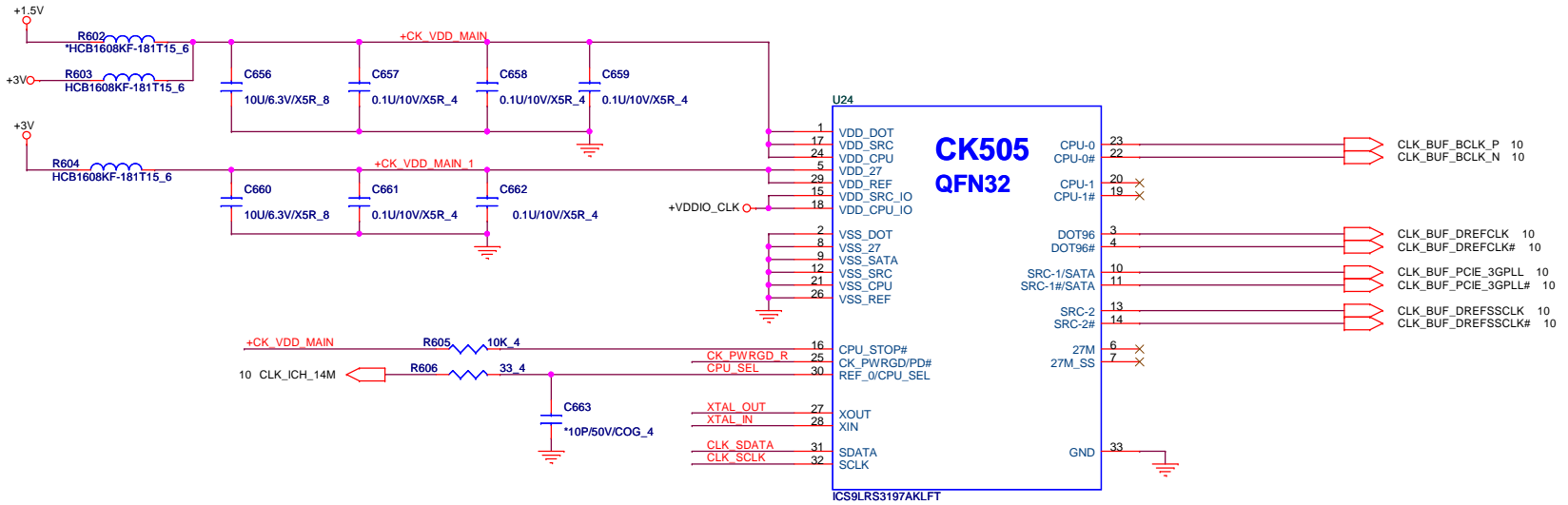

Table of Contents

PAGE	DESCRIPTION
01	BLOCK DIAGRAM
02	FRONT PAGE
03	CLOCK GENERATOR
04-07	Auburndale PROCESSER
08-13	Ibex Peak-M
14-15	DDRIII SO-DIMM
16	LCD & LID CON
17	HDMI PORT(PS8101)
18	CRT CONN
19	AUDIO CODEC(ALC269Q)
20	LAN(8111DL)
21	SATA HDD/CD-ROM
22	USB X2/SIM_CARD/LEDs/RF
23	CARD READER/USB/SIM CONN
24	MINI-Card (WWAN)
25	MINI-Card (WLAN)
26	ONFI
27	Express Card
28	K/B, T/P
29	BlueTooth
30	FAN /THERMAL
31	G-SENSOR
32	B TO B CON
33	TPM & RFID EEPROM
34	KBC IT8502E
35	HOLD & SKEW
36	Discharge
37	Charger (ISL88731)
38	DDR3/0.75V(TPS51116REGR)
39	1.05V_VTT (RT8204)
40	3V/5V (ISL6237IRZ-T)
41	CPU (ISL62882)
42	GFX_VCC (MAX17028)
43	XDP & JTAG
44	Power Block Dianram
45	Schematic Value Descript
46	BOM Matrix Table

Power States

POWER PLANE	VOLTAGE	PAGE	DESCRIPTION	CONTROL SIGNAL	ACTIVE IN
VIN	10V~+20V	16,36,37,38,39,40,41,42	MAIN POWER		S0-S5
+3VRTC	+3.0V~+3.3V	9,12,34	RTC		S0-S5
3VPCU	+3.3V	9,16,20,23,28,32,34,36,37,40,42	ITE8502 POWER	3V5V_EN	S0-S5
5VPCU	+5V	36,37,38,39,40,42	DC/DC POWER IC SOURCE	3V5V_EN	S0-S5
+15V	+15V	16,31,36,38,39,40	LARGE POWER	3V5V_EN	S0-S5
LANVCC	+3.3V	20,36	LAN POWER	LAN_ON	
5V_S5	+5V	12,22,23,36	PCH SUS POWER	S5_ON	S0-S3
3V_S5	+3.3V	8,9,10,11,12,36	Sys Management,PCH Resume Well, Intel HD Audio,USB,WLAN,WiMAX POWER	S5_ON	S0-S3
5VSUS	+5V	16,32,36,41,42	SLP_S4# CTRLD POWER	SUSON	S0-S3
3VSUS	+3.3V	8,23,27,34,36,42	SLP_S4# CTRLD POWER	SUSON	S0-S3
1.5VSUS	+1.5V	4,6,12,14,15,36,38,39	DDR3 SODIMM POWER	SUSON	S0-S3
0.75VSMDDR_VTERM	+0.75V	14,15,36,38	DDR3 SODIMM REFERENCE POWER	MAINON	S0
+5V	+5V	8,12,16,17,18,19,21,28,30,34,36,37	SLP_S3# CTRLD POWER	MAINON	S0
+3V	+3.3V	3,4,8,9,10,11,12,14,15,16,17,18,19,20,21,22 23,24,25,26,27,29,30,31,32,33,34,36,37,38, 39,40,41,42,43	SLP_S3# CTRLD POWER	MAINON	S0
+1.8V	+1.8V	6,12,26,36,42	LVDS,NVM POWER	MAINON	S0
+1.5V	+1.5V	12,24,25,27,38,39	Mini PCIe,Express Card POWER	MAIND	S0
+1.05V_VTT	+1.05V	3,4,6,8,10,11,12,36,39,41,43	AuBurndale VTT POWER/PCH CORE POWER	MAINON	S0
+VCC_GFX_CORE		6,36,42	VGA CORE POWER	GFXVR_EN	S0
VCC_CORE		6,36,41	CPU CORE POWER	VRON	S0
LCDVCC	+3.3V	16	LCD Power	ENVDD	S0
+5V_ODD	+5V	21	ODD Power	MAINON#	S0
+5V_HDD	+5V	21	HDD Power	MAINON#	S0
BAT-V	+10V~+17V	37	MAIN BATTERY	CHG_PBATT	S0-S5



	0	1
CPU_SEL	CPU0/1=133MHz (default)	CPU0/1=100MHz

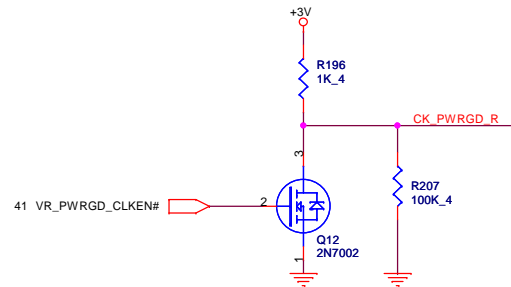

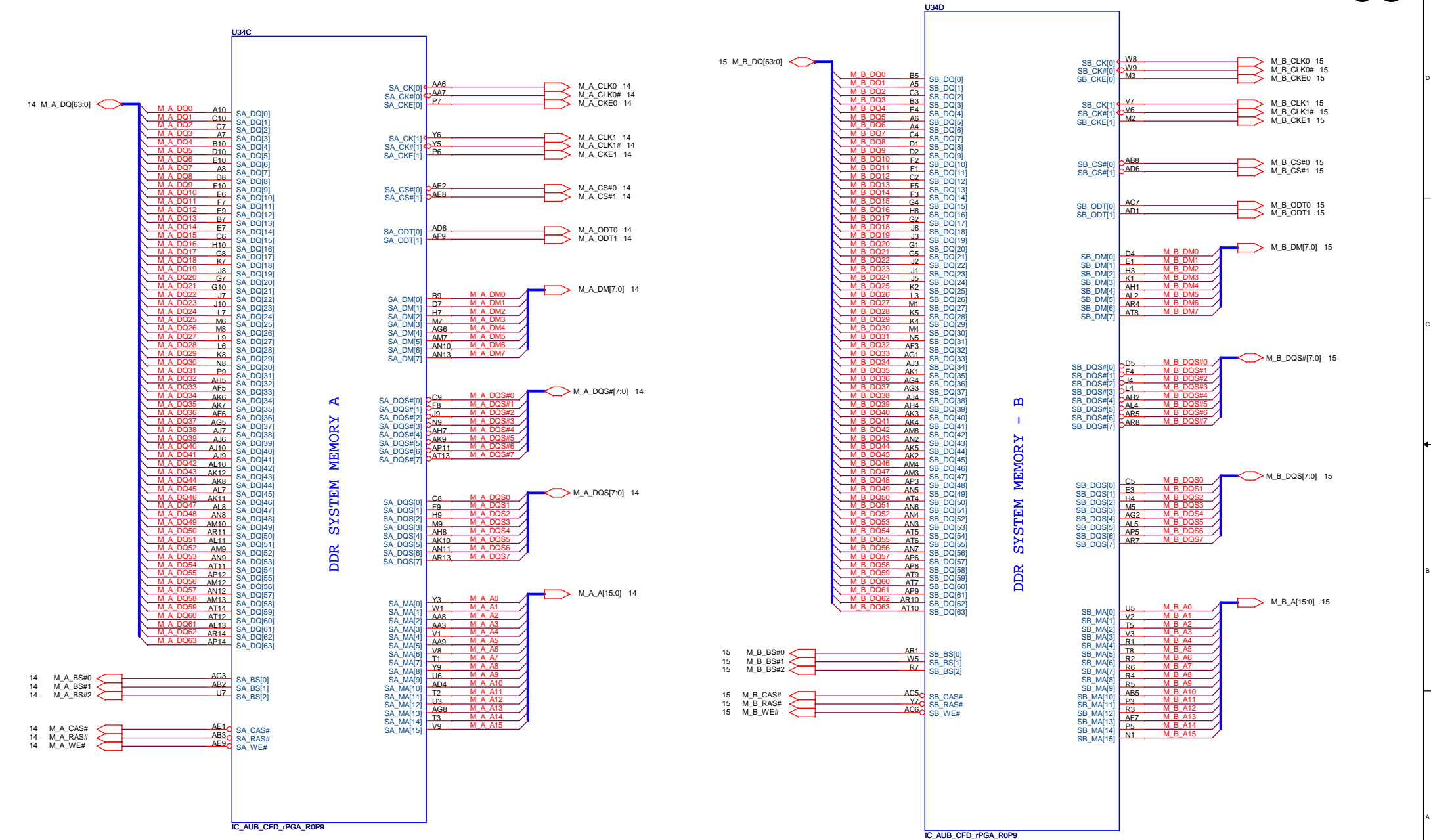

IC_AUB_CFD_rPGA_R0P9

IC_AUB_CFD_rPGA_R0P9

LD-Note Calpella UMA
Quanta Computer Inc.

Size	Document Number	Rev
Custom	AUBURNDA 2/4	
Date:	Saturday, November 07, 2009	Sheet 5 of 50

CPU Core Power

AUBURNDALE PROCESSOR (GRAPHICS POWER)

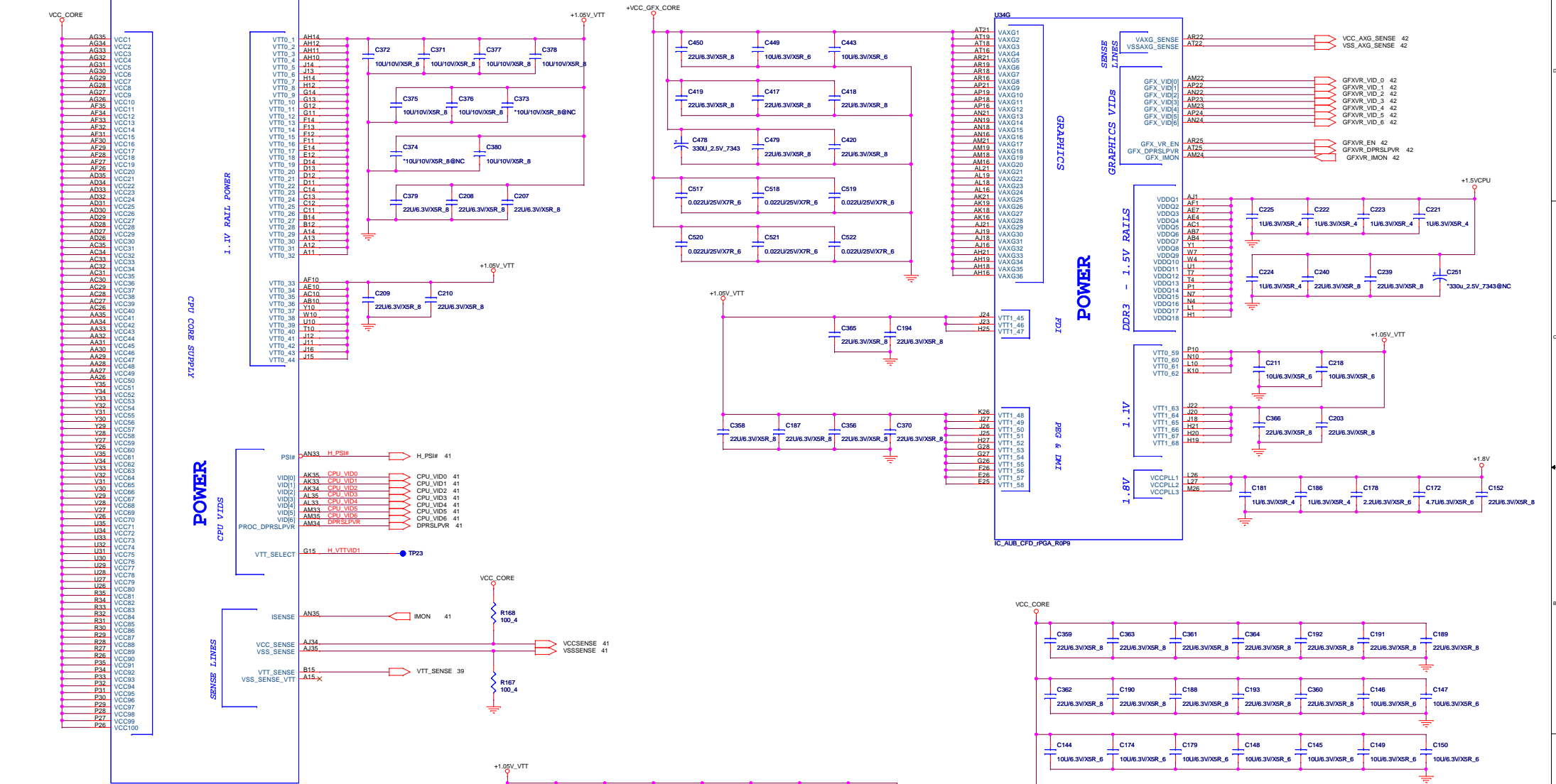

AUBURNDALE PROCESSOR (POWER)

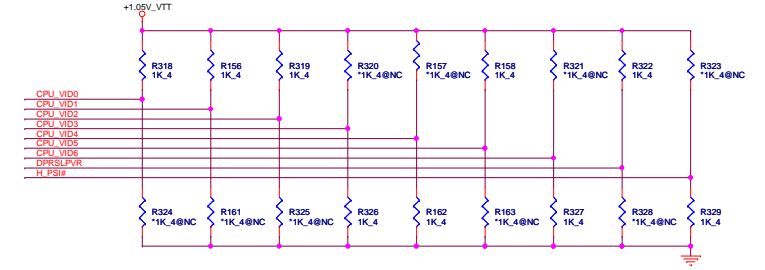

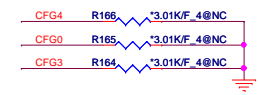
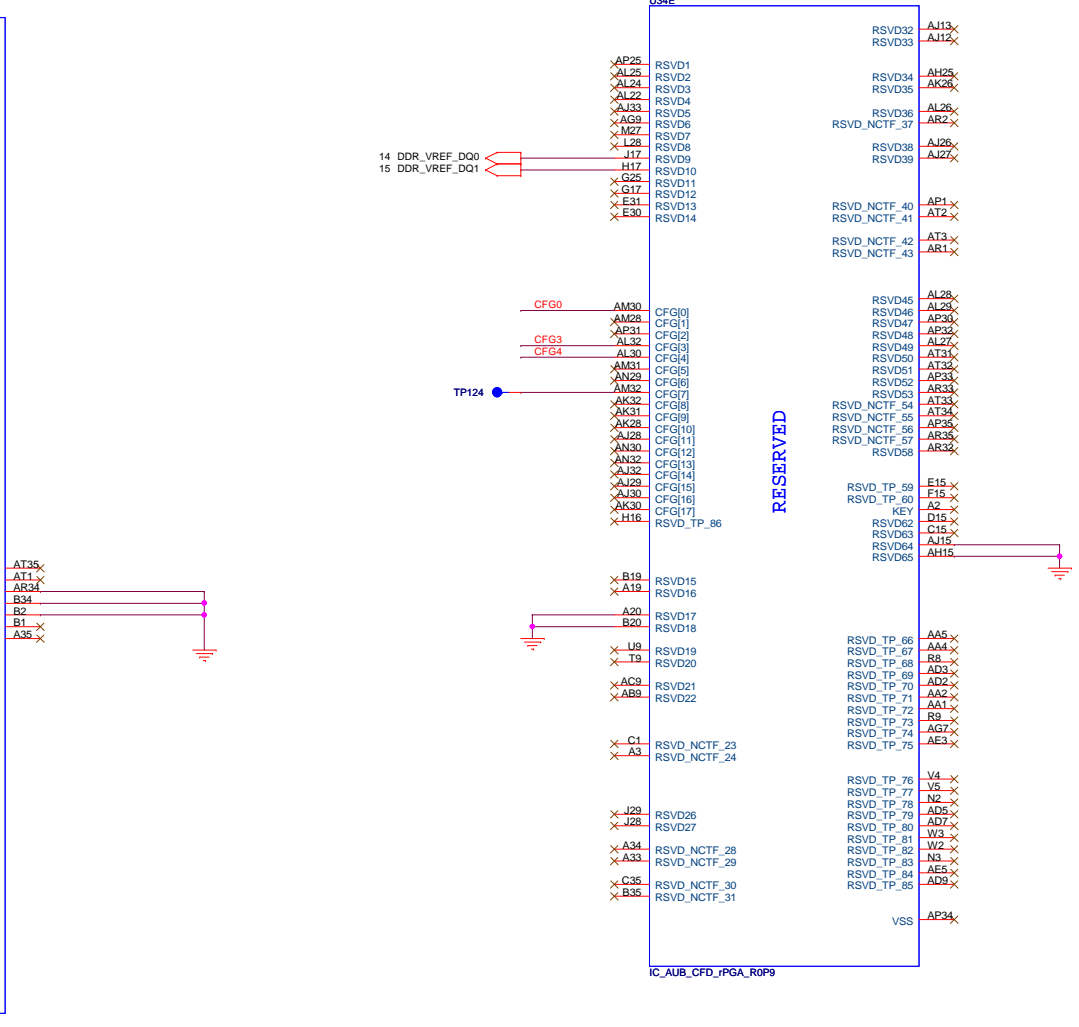
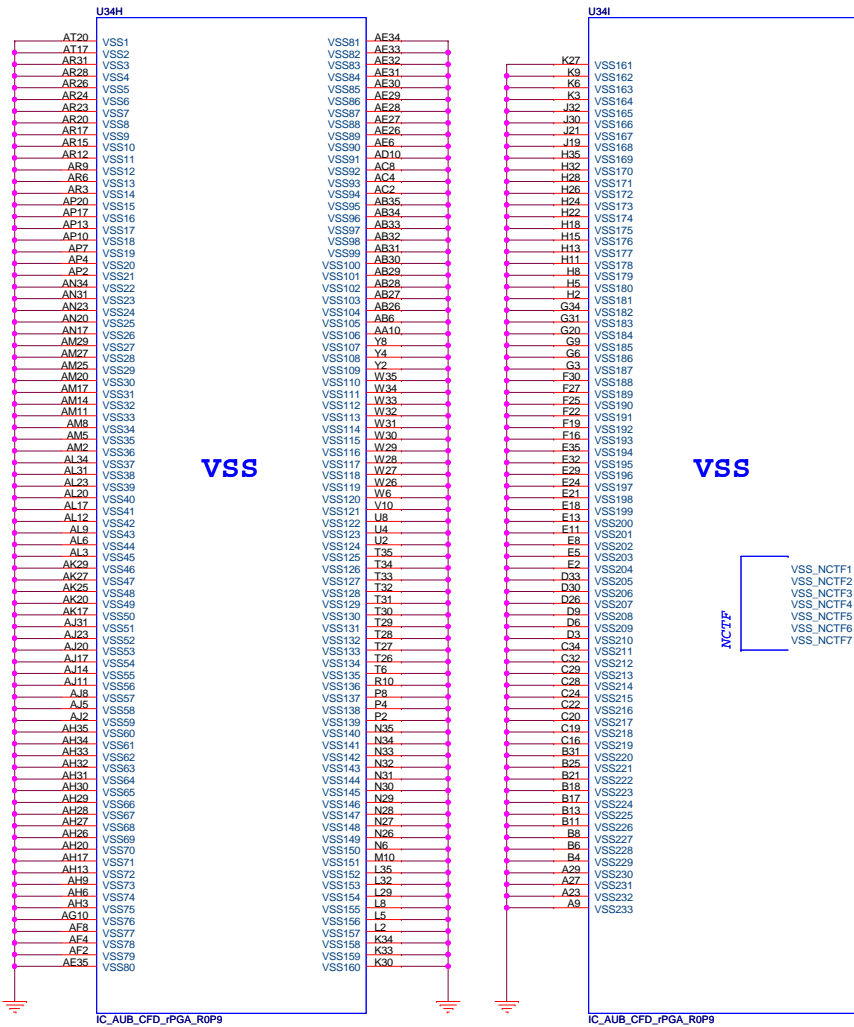

	1	0
CFG4 (Display Port Presence)	Disabled; No Physical Display Port attached to Embedded Display Port	Enabled; An external Display port device is connected to the Embedded Display port
CFG0 (PCI-Epress Configuration Select)	Single PEG	Bifurcation enabled
CFG3 (PCI-Epress Static Lane Reversal)	Normal Operation	Lane Numbers Reversed

LD-Note Calpella UMA
Quanta Computer Inc.
AUBURNDA 4/4 (GND)

Size: Custom
 Document Number: AUBURNDA 4/4 (GND)
 Date: Saturday, November 07, 2009 Sheet 7 of 50

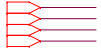

IBEX PEAK-M (DMI, FDI, GPIO)

IBEX PEAK-M (LVDS, DDI)

EC-C-19

U38C

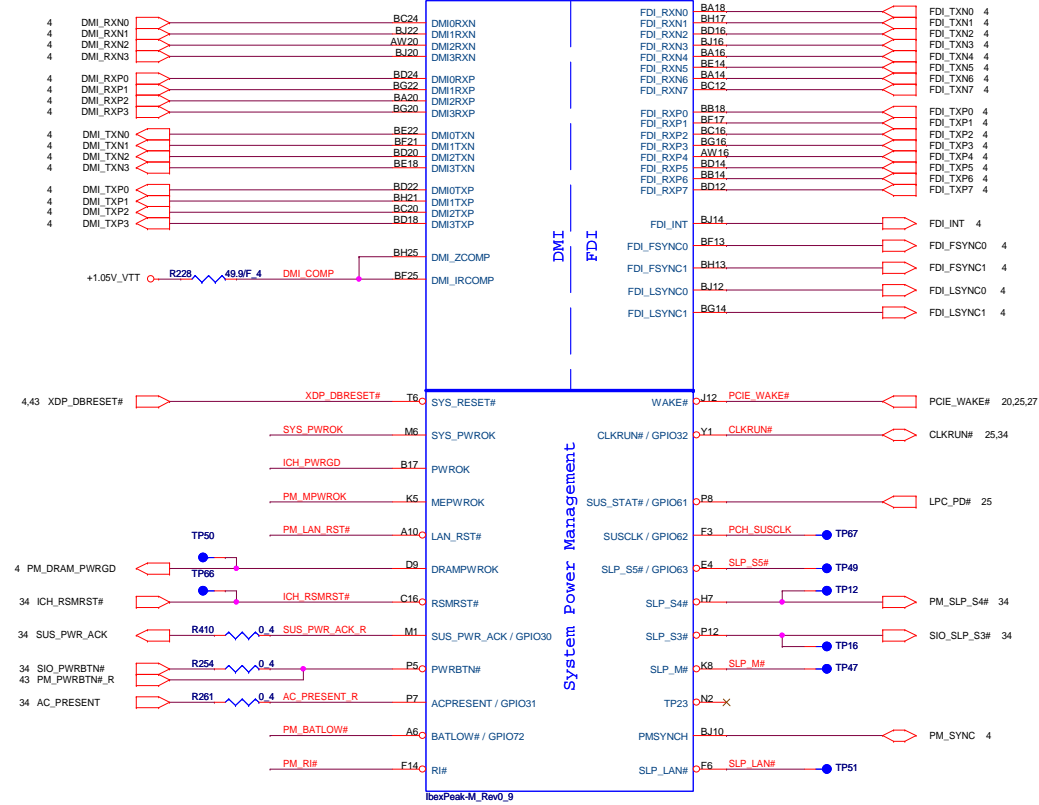

EC-C-19

U38D

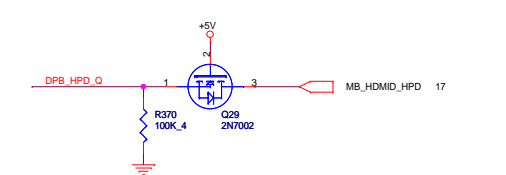
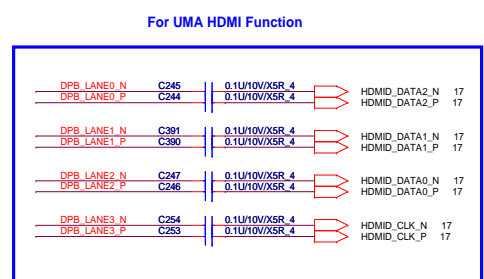
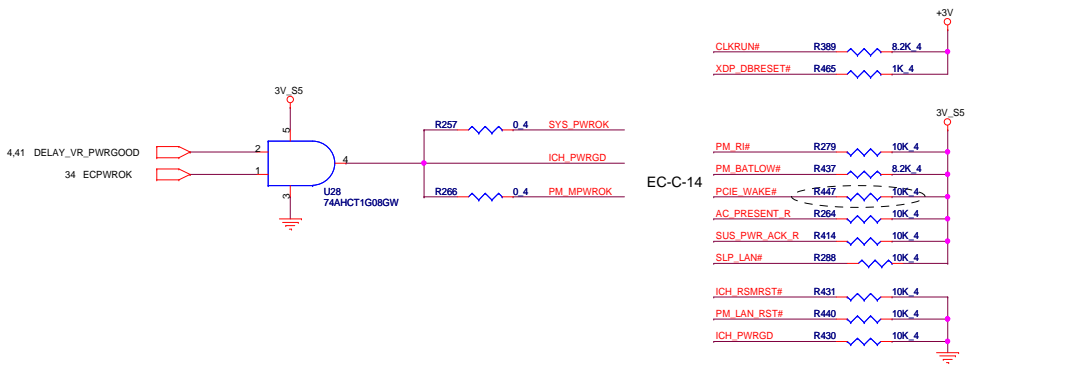
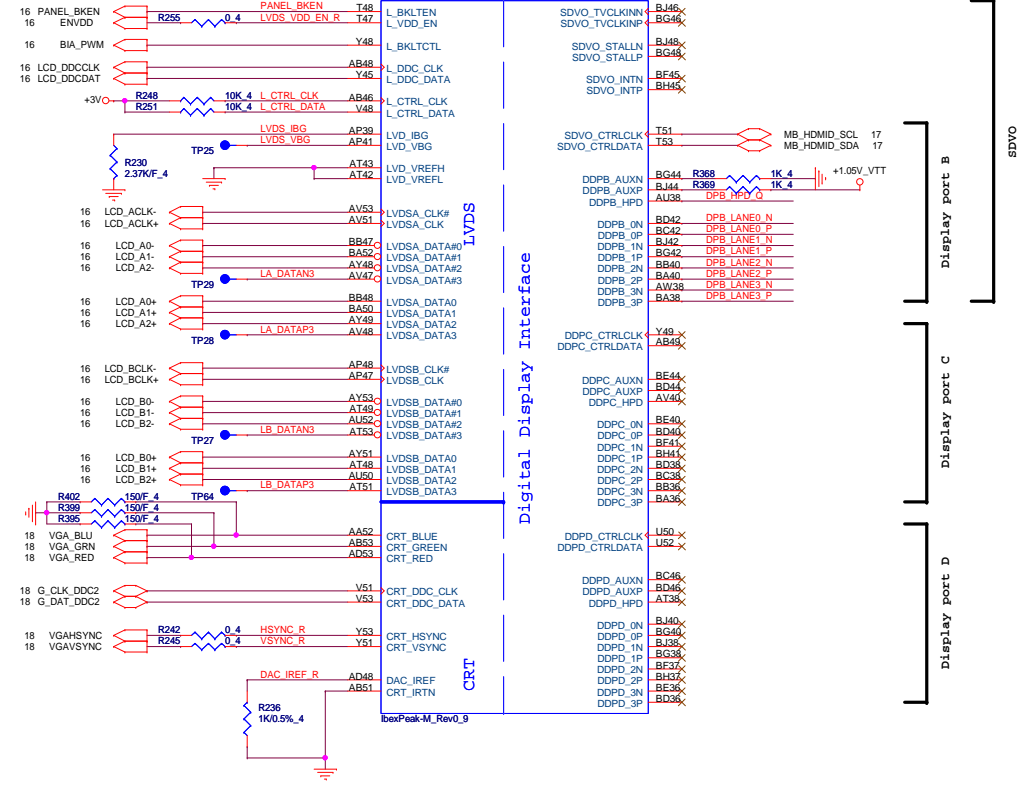

RTC Circuitry

CMOS Settings	J5
Clear CMOS	1-2
Save CMOS	1-X (Default)

TPM Settings	J4
Clear ME RTC registers	1-2
Save ME RTC registers	1-X (Default)

INTVRMEN - Integrated SUS 1.1V VRM Enable
 High - Enable Internal VRs

IBEX PEAK-M (HDA, JTAG, SATA)

EC-C-19

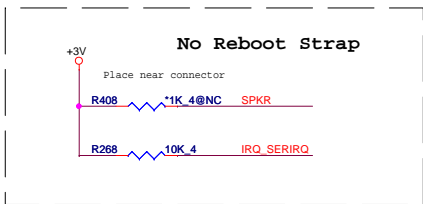
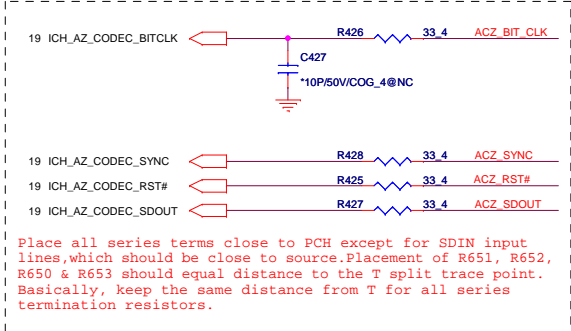
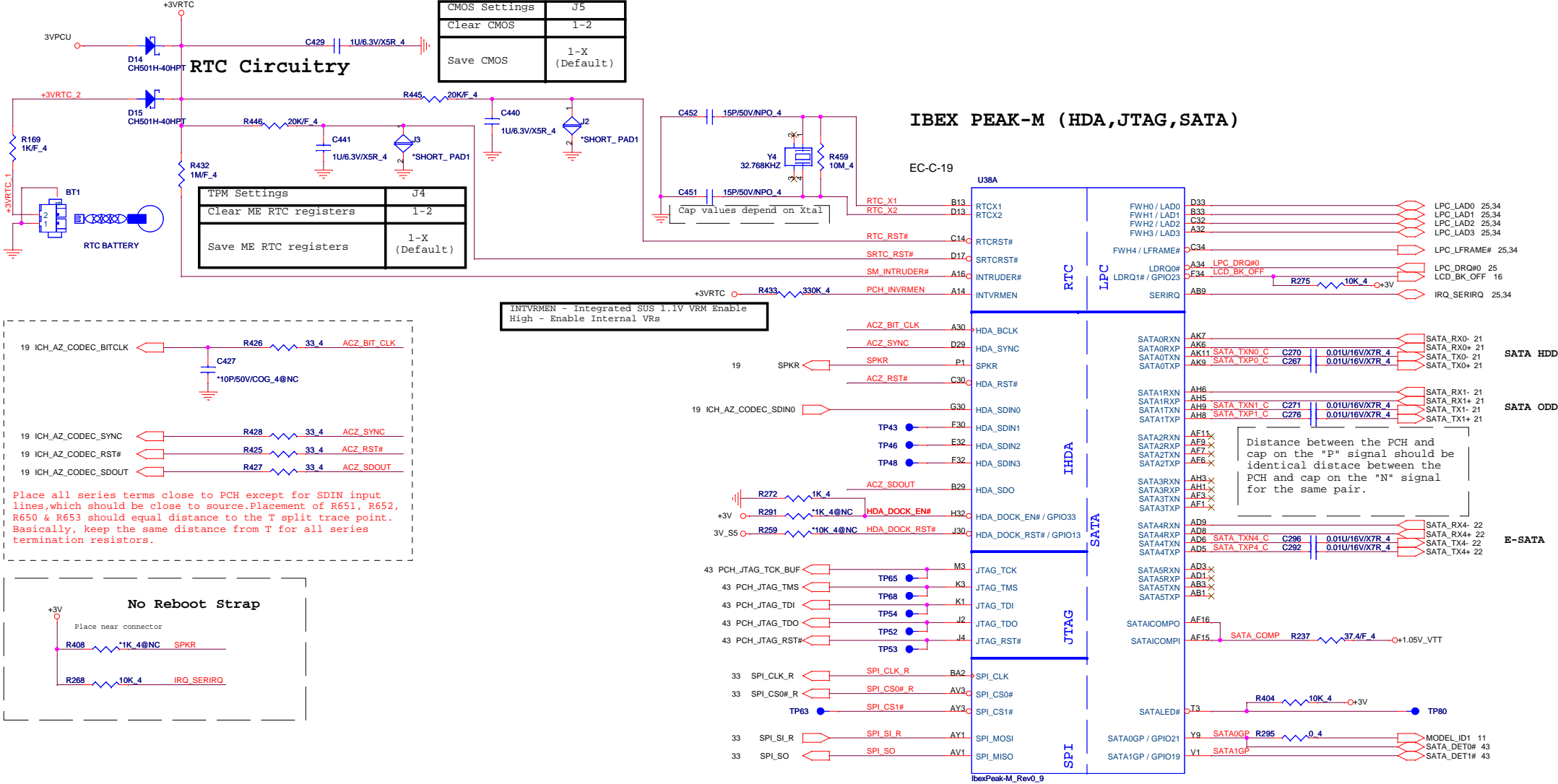

Distance between the PCH and cap on the "P" signal should be identical distance between the PCH and cap on the "N" signal for the same pair.

LD-Note Calpella UMA
Quanta Computer Inc.

Size	Document Number	Rev
Custom	IBEX PEAK-M 2/6	
Date:	Saturday, November 07, 2009	Sheet 9 of 50

Feature set	SKU Names			
	Q57	H57	H55	P55
PCIe 2.0 Ports	8	8	6 ₁	8
USB 2.0 Ports	14	14	12 ₂	14

*1: USB ports 6 and 7 are disabled
 *2: PCIe ports 7 and 8 are disabled

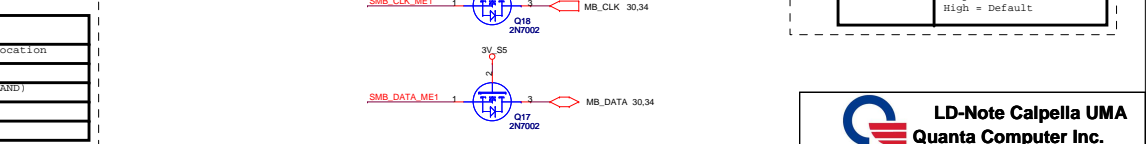
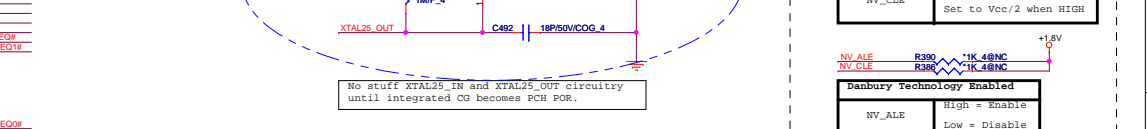
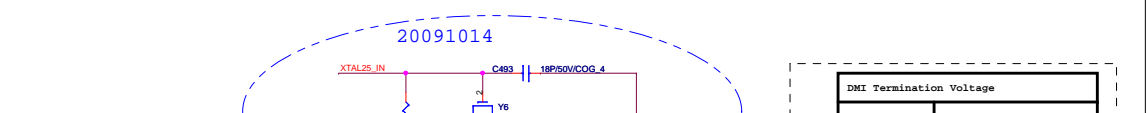
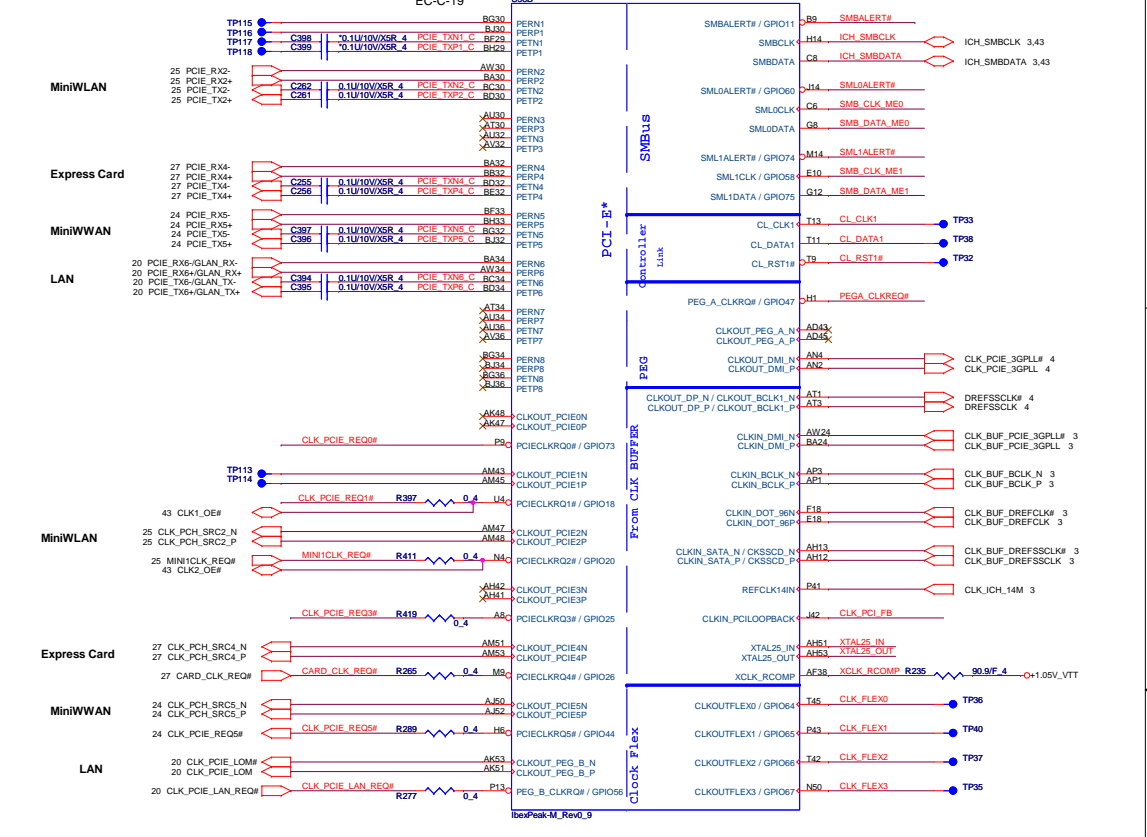
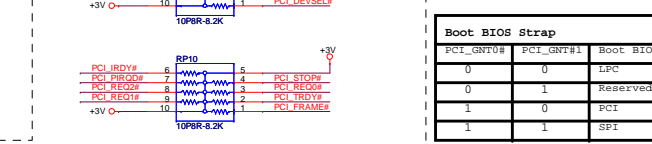
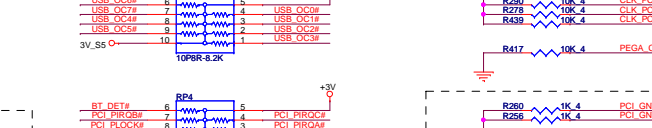
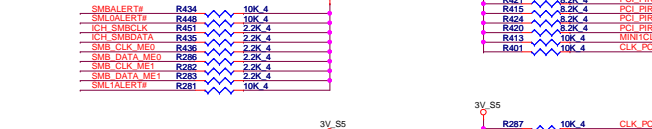
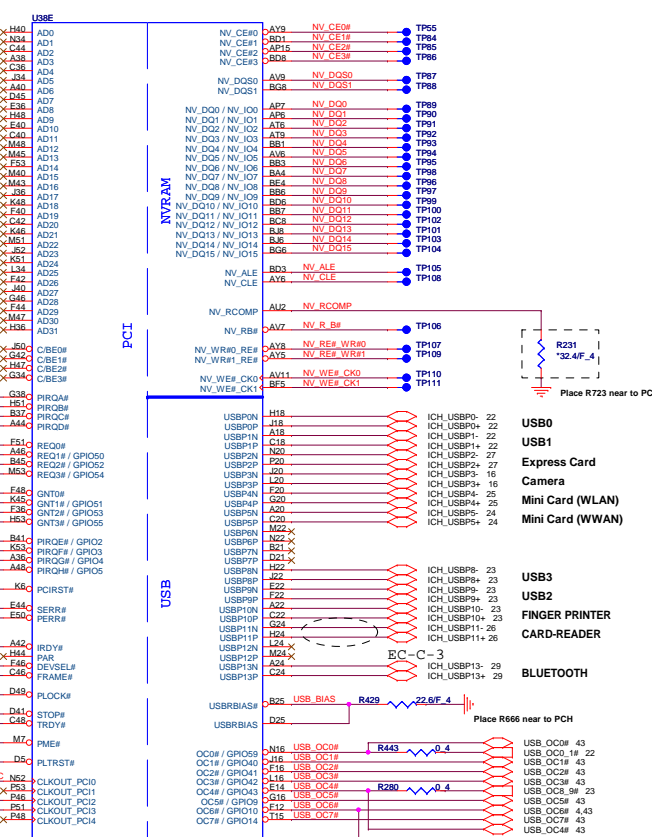
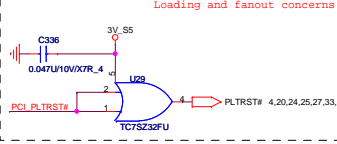
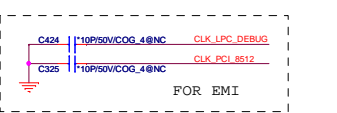
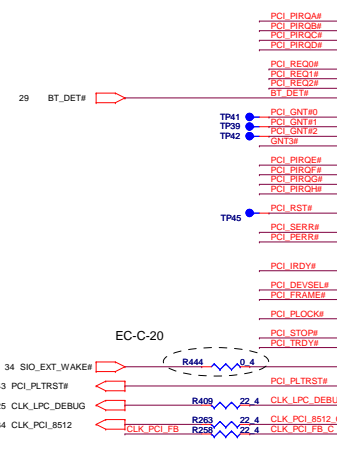

LD-Note Calpella UMA
 Quanta Computer Inc.
 IBEX PEAK-M 3/6
 Date: Saturday, November 07, 2008 Sheet: 10 of 50

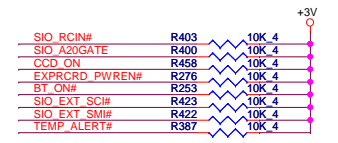
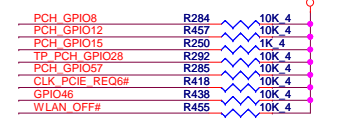
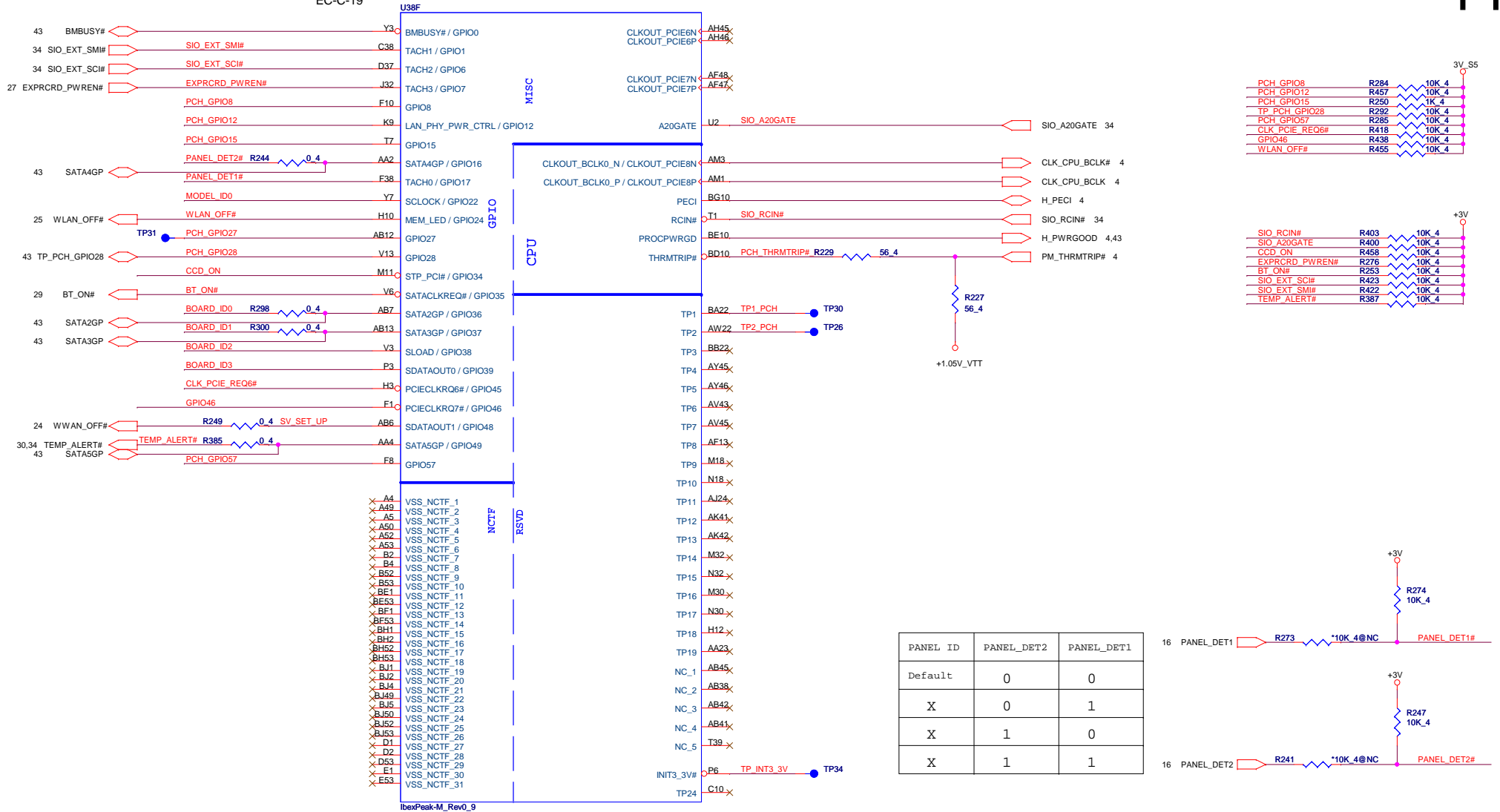

PANEL ID	PANEL_DET2	PANEL_DET1
Default	0	0
X	0	1
X	1	0
X	1	1

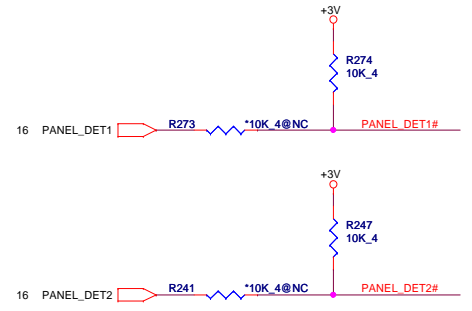

Board ID For Function	ID3 GPIO39	ID2 GPIO38	ID1 GPIO37	ID0 GPIO36
SDV	0	0	0	0
SIV	0	0	0	1
SIT	0	0	1	0
SVT	0	0	1	1
SOVP	0	1	0	0

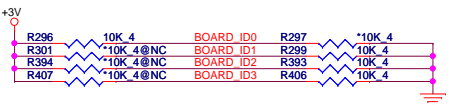

Model ID	MODEL_ID0	MODEL_ID1
13"	0	0
14"	0	1
15"	1	0
Default	1	1

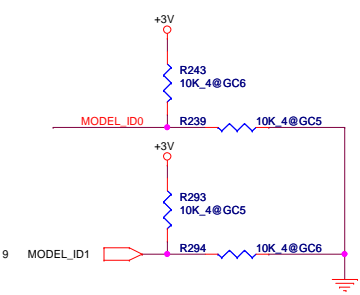

SV_SET_UP 1-X High = Strong (Default)

LD-Note Calpella UMA
Quanta Computer Inc.

Size: Custom Document Number: **IBEX PEAK-M 4/6** Rev: _____
Date: Sunday, November 08, 2009 Sheet 11 of 50

EC-C-19

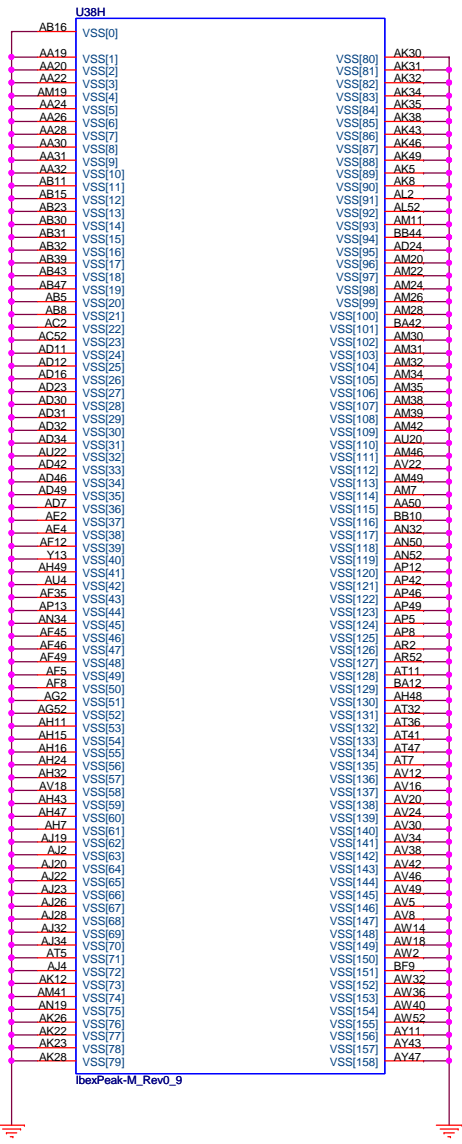

IbexPeak-M_Rev0_9

EC-C-19

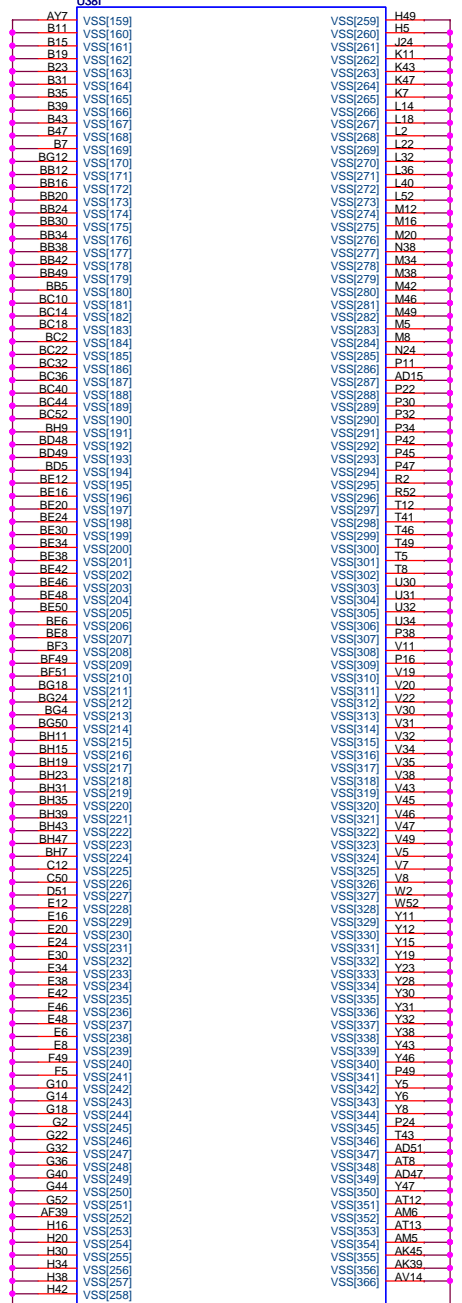

IbexPeak-M_Rev0_9

LD-Note Calpella UMA
Quanta Computer Inc.

Size	Document Number	Rev
Custom	IBEX PEAK-M 6/6	
Date:	Saturday, November 07, 2009	Sheet 13 of 50

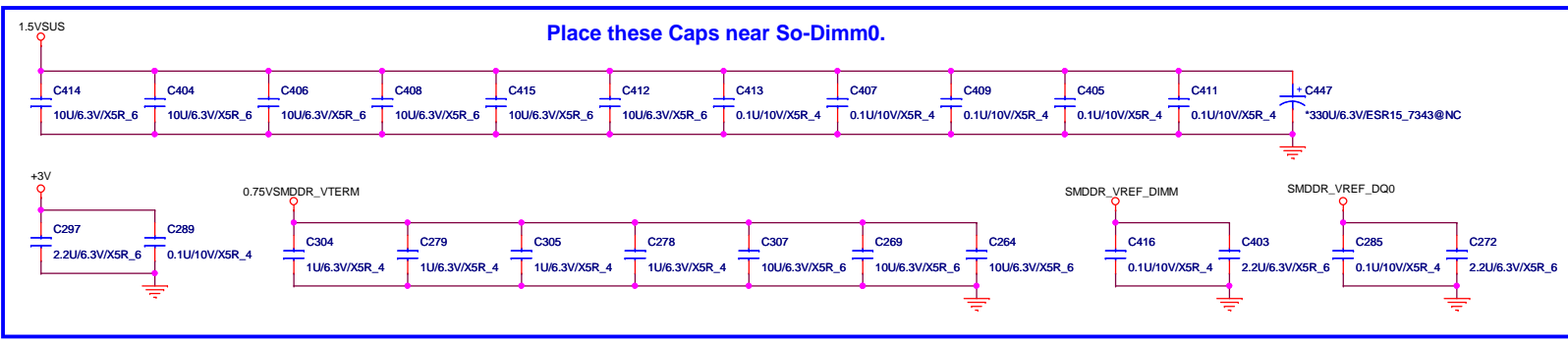
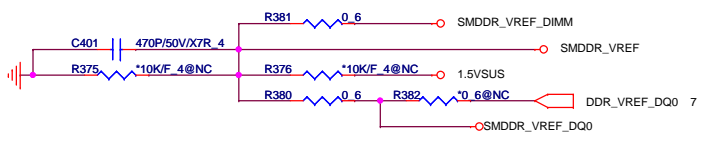
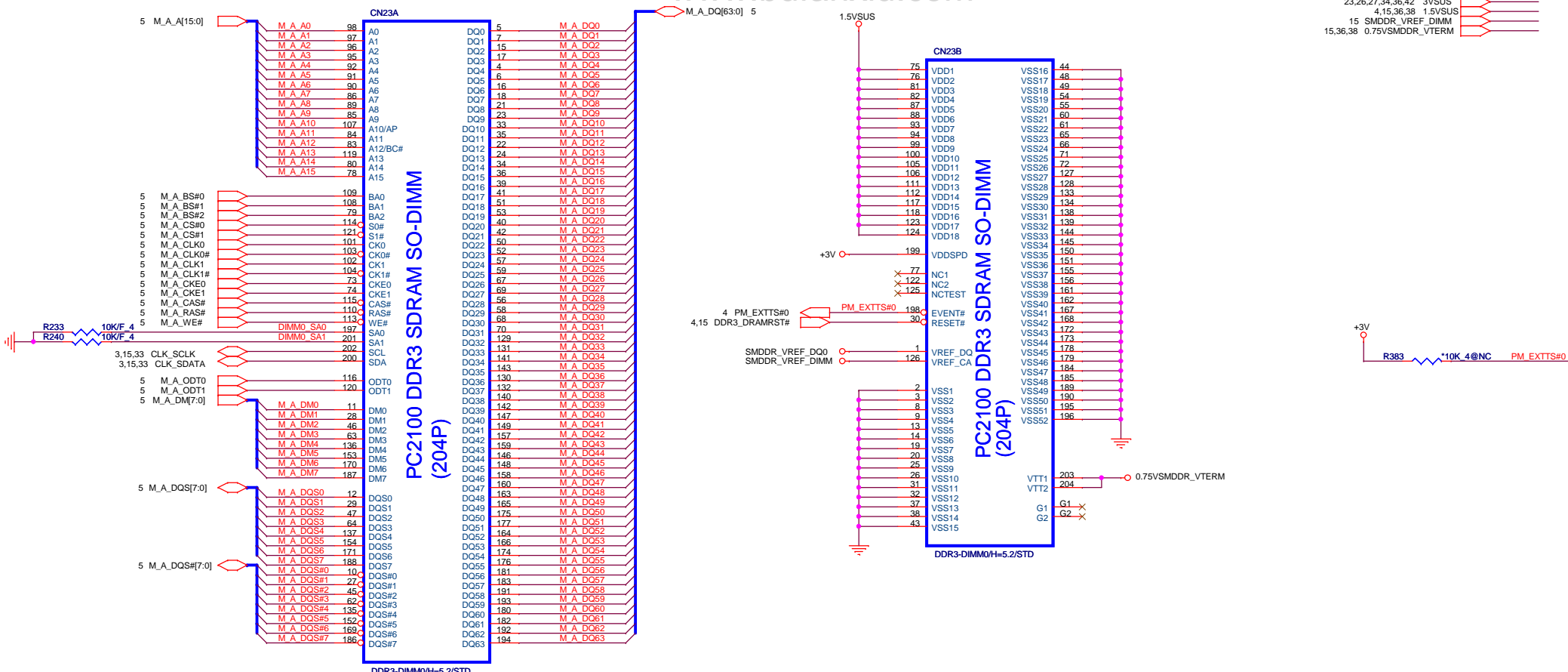

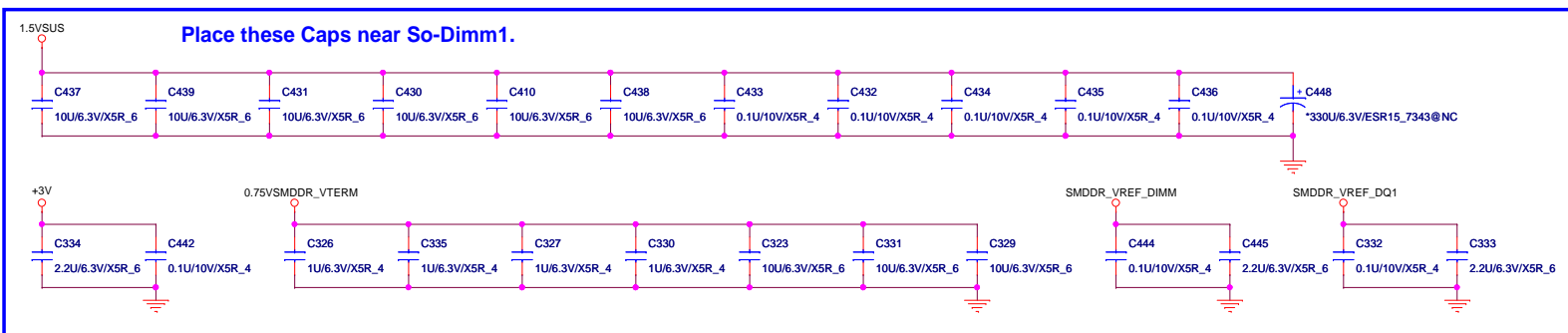
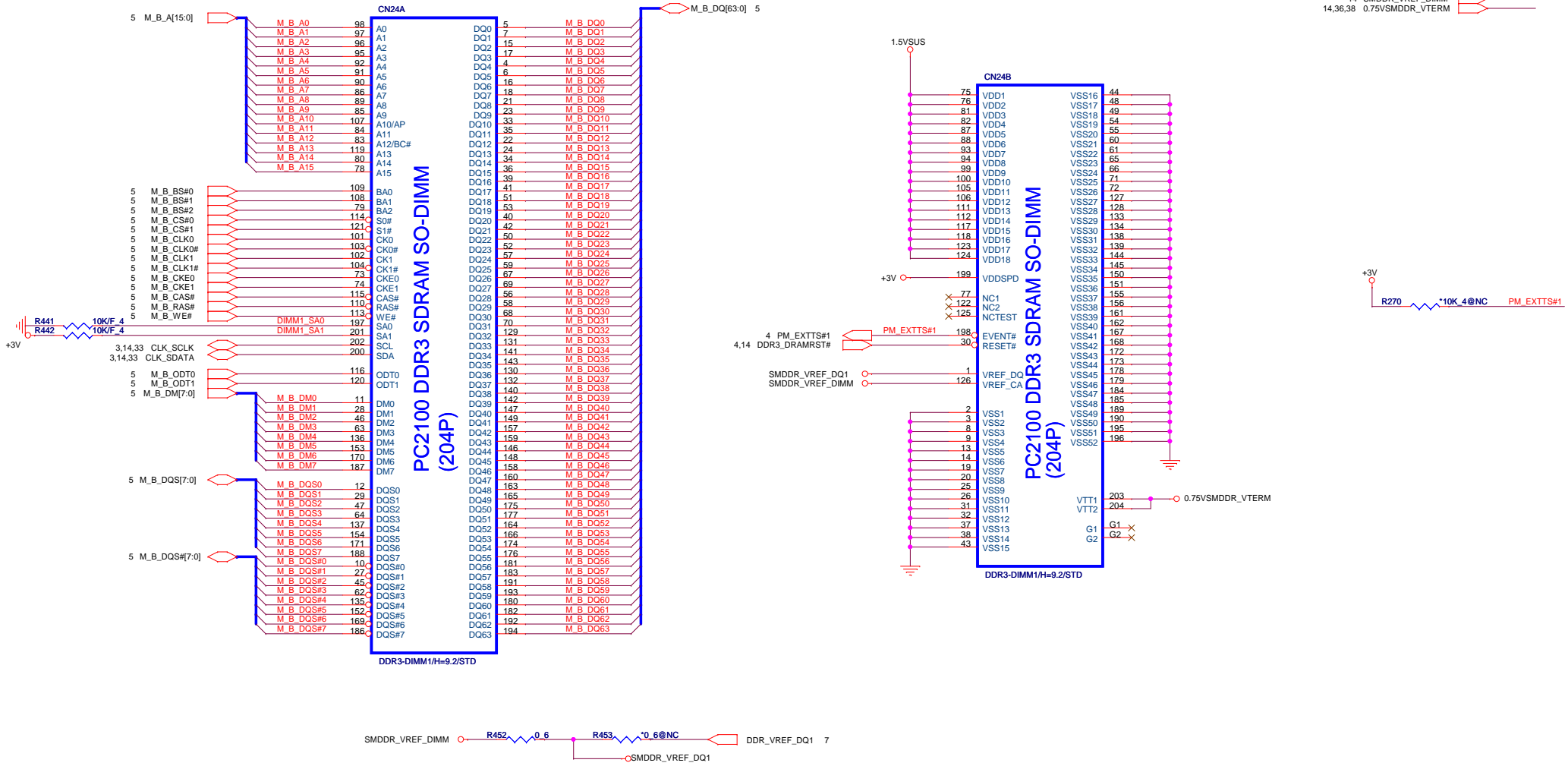

LCDVCC

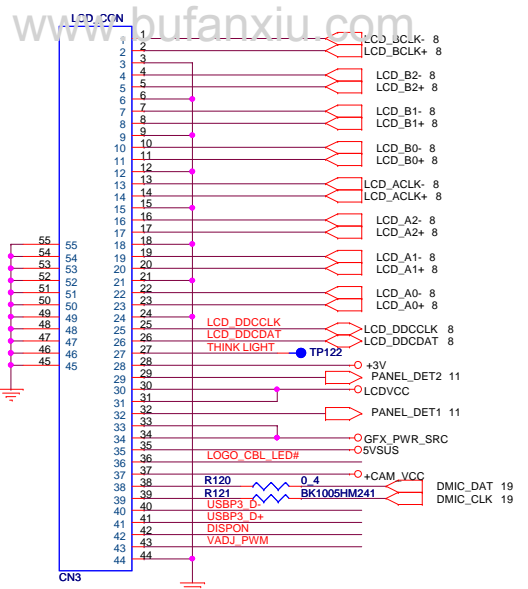
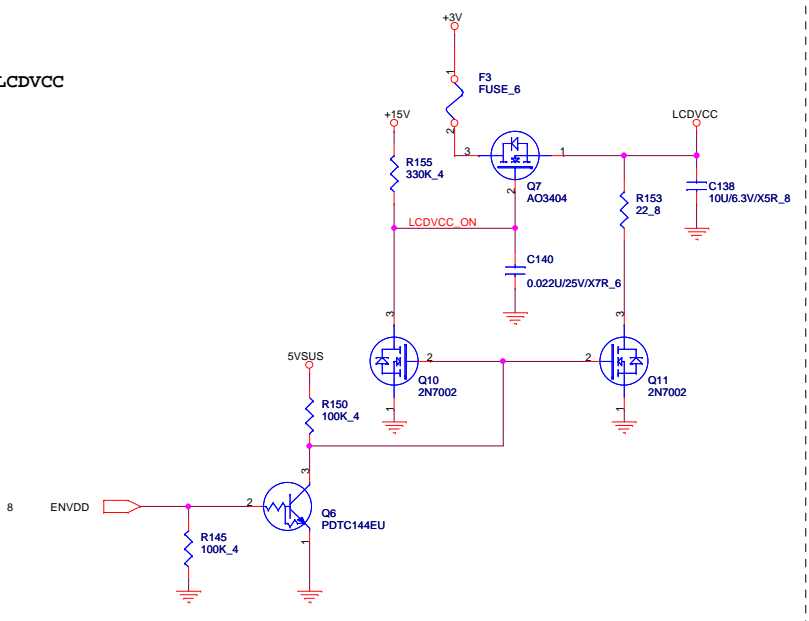

Address : A9H --Contrast
AAH --Backlight

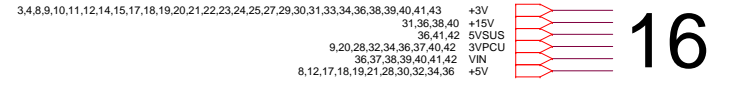

back light

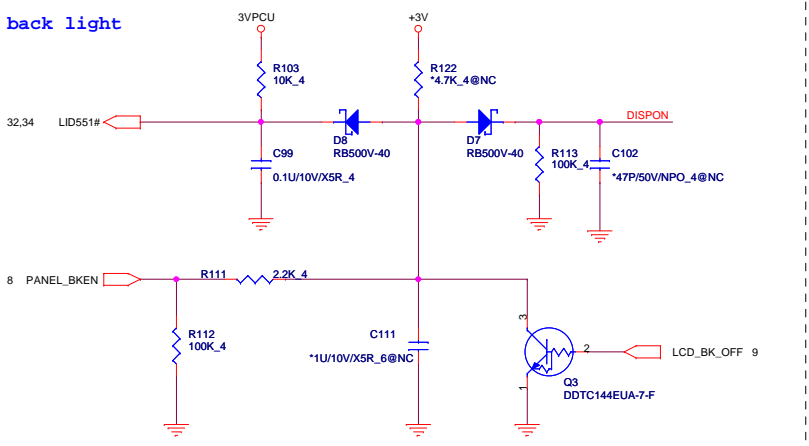

LOGO LED ON

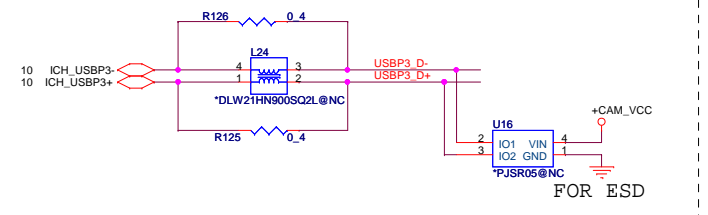
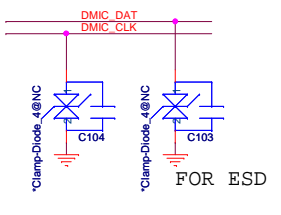
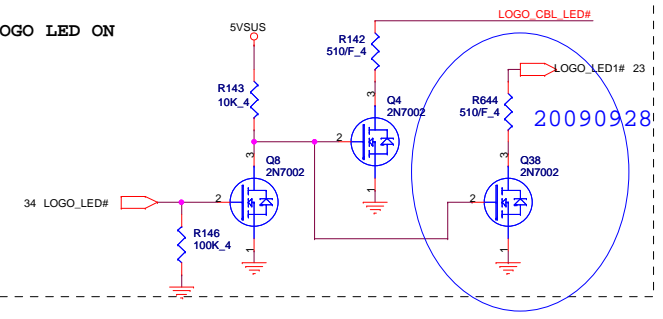

CAMERA VCC Control

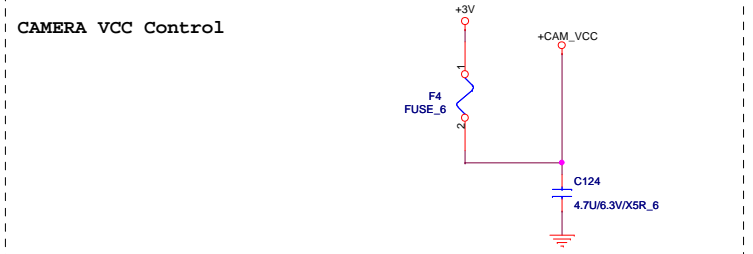

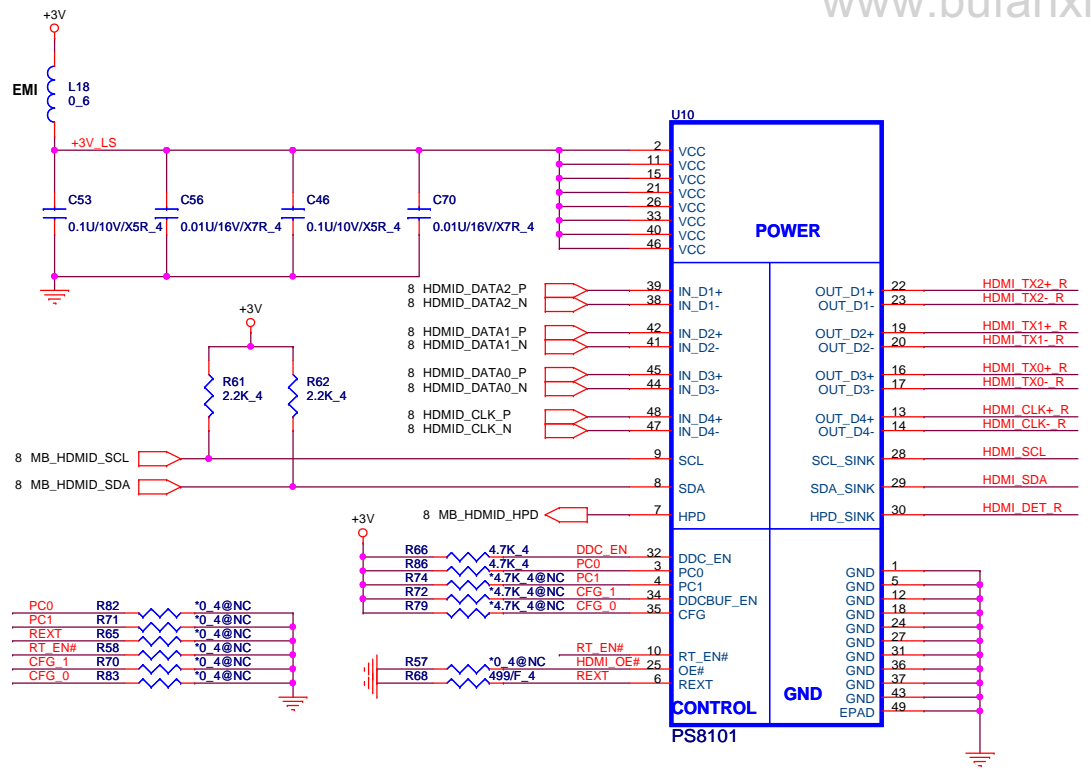

EQUALIZATION SETTING

PC1:PC0=0:0 8dB
 PC1:PC0=0:1 4dB Recommended
 PC1:PC0=1:0 12dB
 PC1:PC0=1:1 0dB

PS8101 Pin34/35 is NC

SCLZ/SDAZ Low-level input/output Voltage
 CFG1:CFG0=0:0 VIL:<0.4V VOL:0.6V (Default)
 CGF1:CGF0=0:1 VIL:<0.36V VOL:0.55V
 CGF1:CGF0=1:0 VIL:<0.44V VOL:0.65V
 CGF1:CGF0=1:1 VIL:<0.36V VOL:0.6V

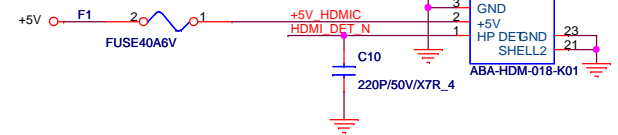
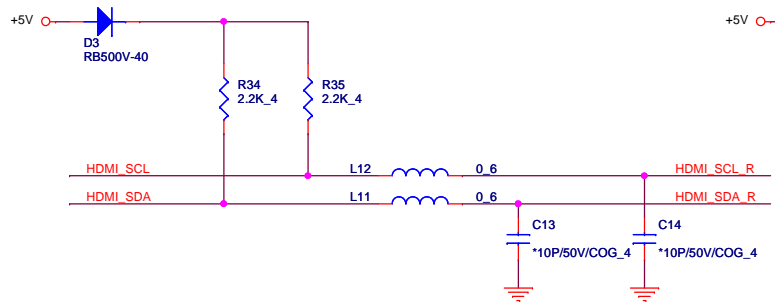
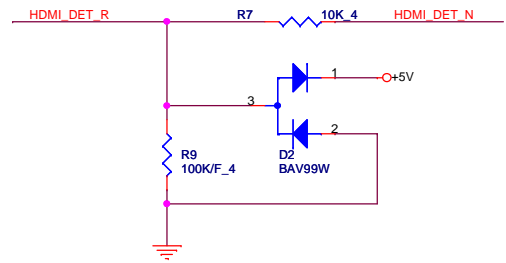
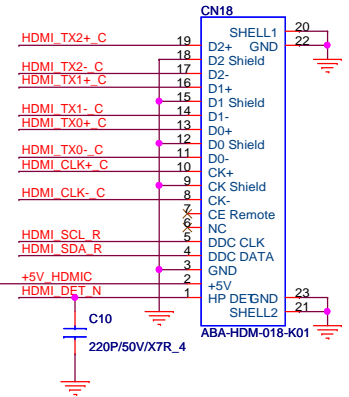
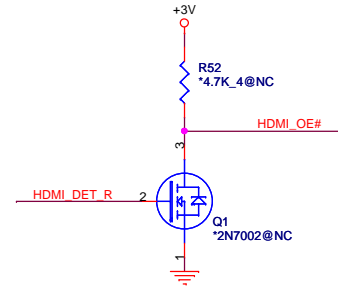
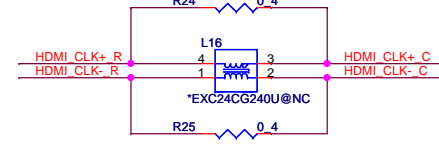
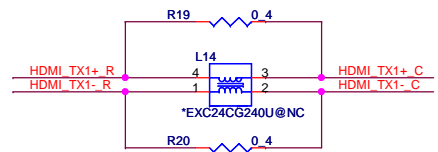
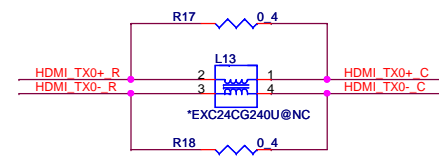
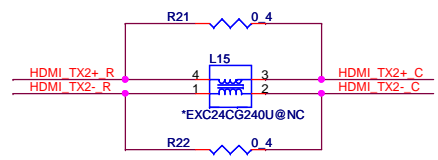
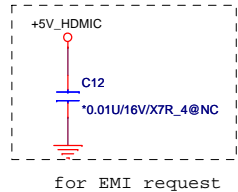

Layout Note:
Setting R,G,B trace
impedance to 50 ohm.

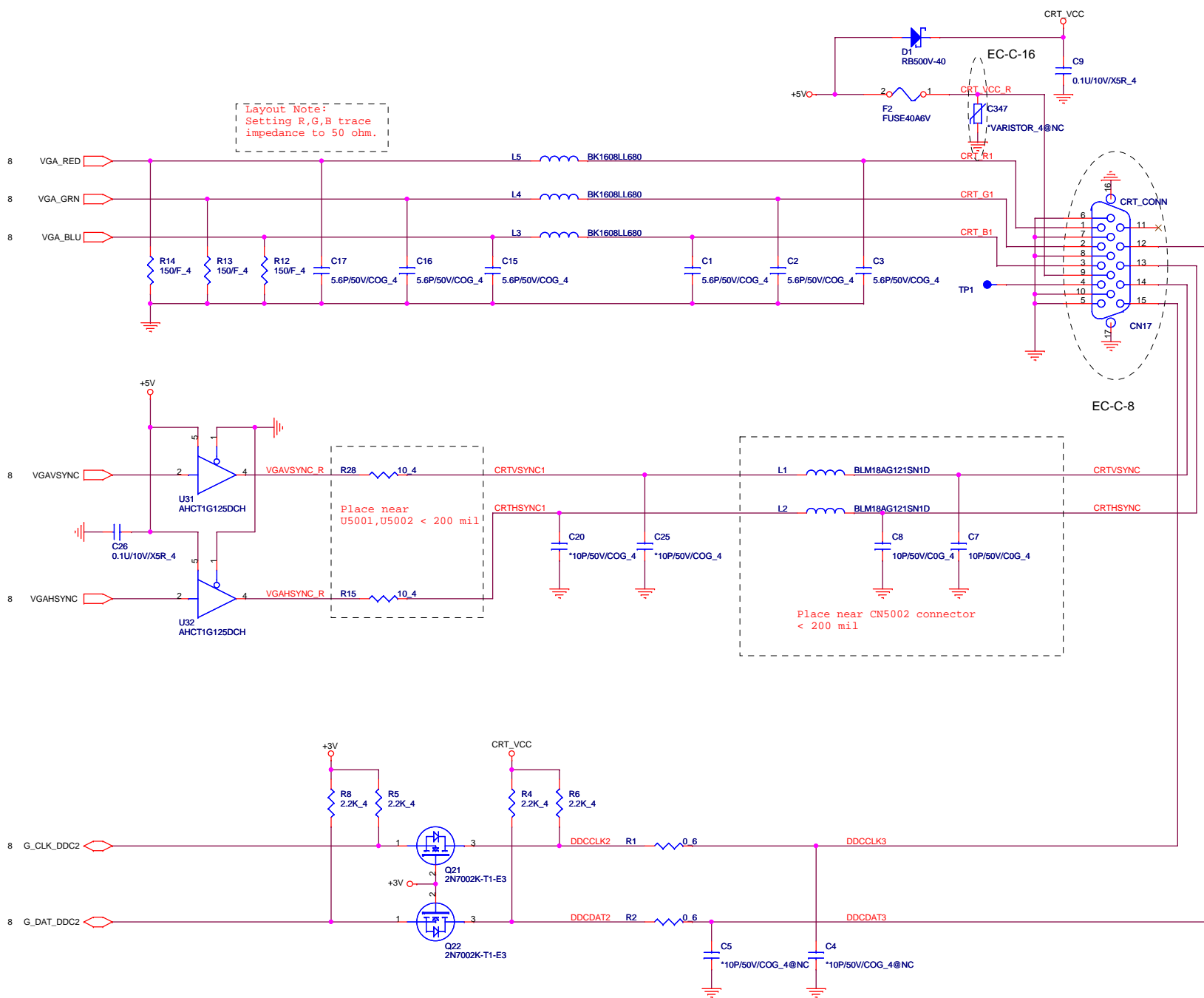

ESD PROTECTION

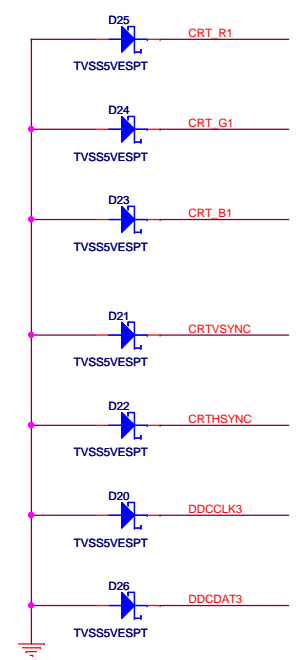

HDAudio Codec

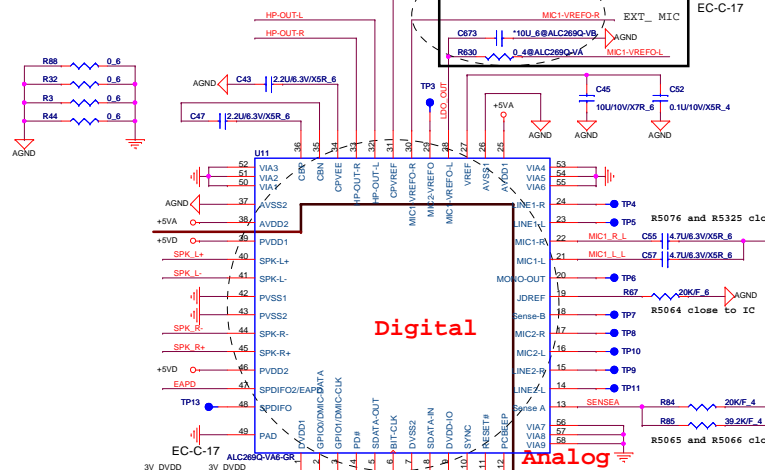

Digital

Analog

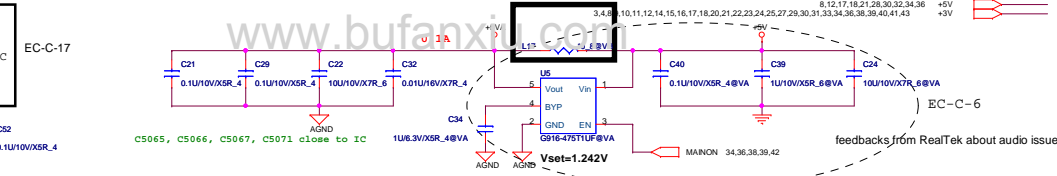

www.bufoanxi.com

feedbacks from RealTek about audio issue

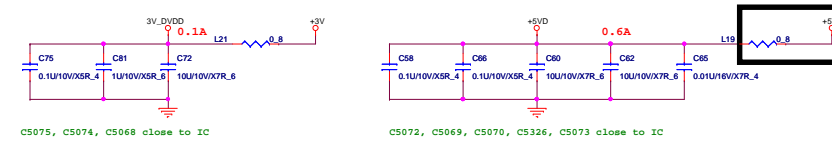

Internal Speaker

20091007

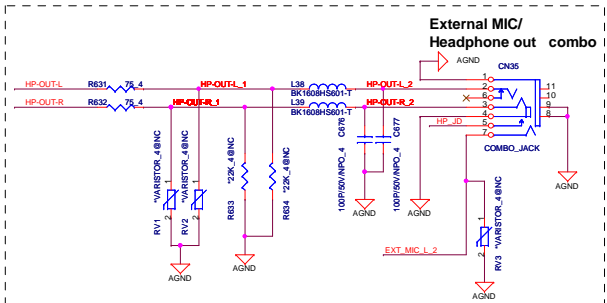

External MIC/Headphone out combo

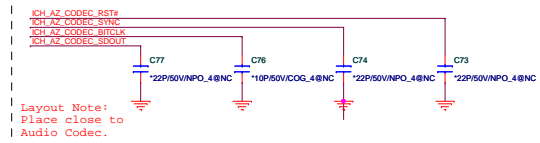

Layout Note: Place close to Audio Codec.

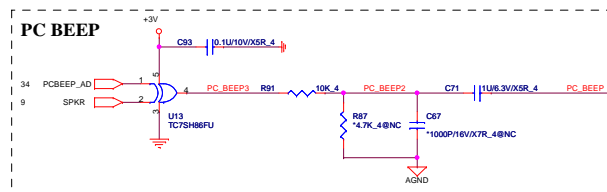

PC BEEP

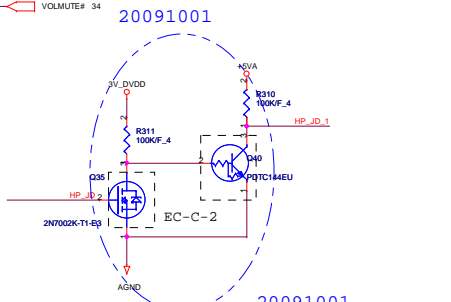

20091001

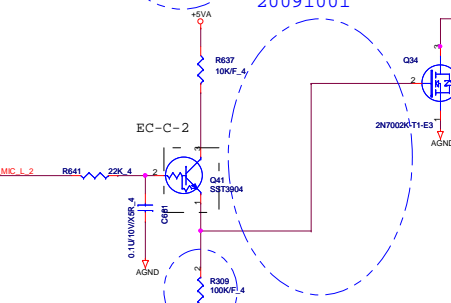

20091001

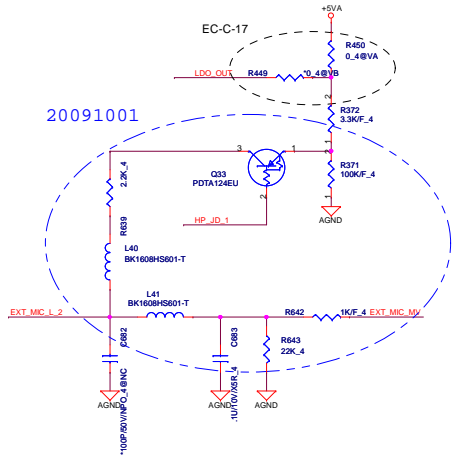

20091001



EC-C-17

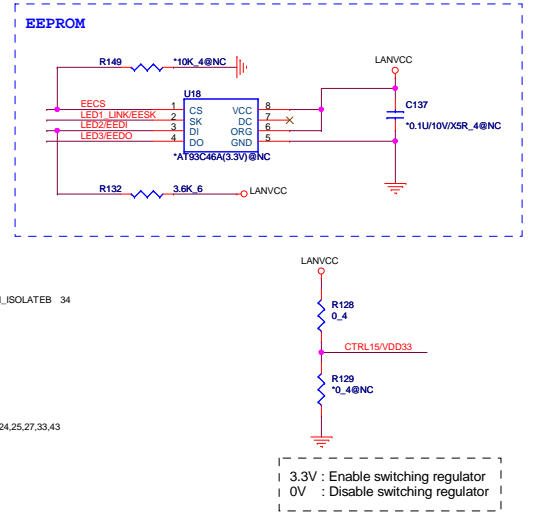
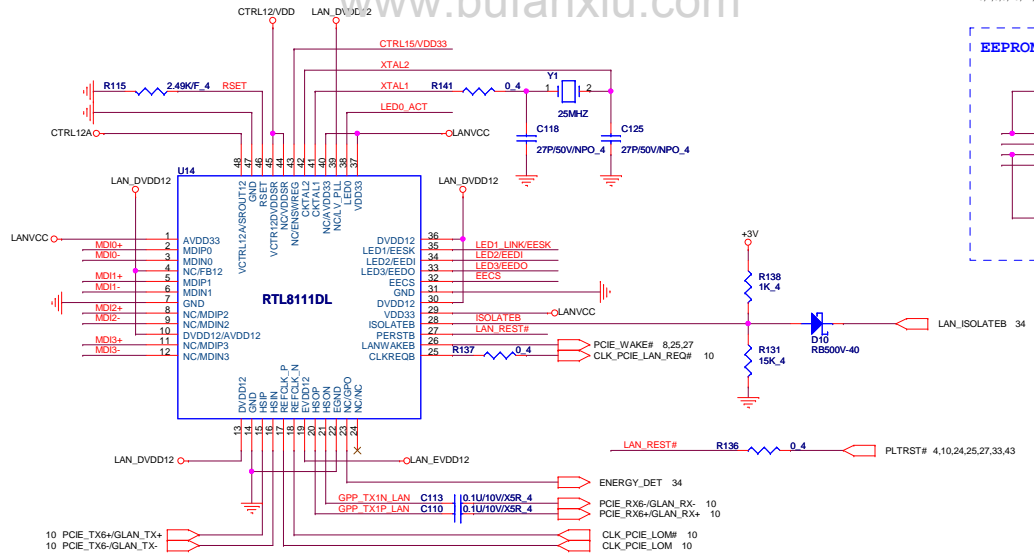
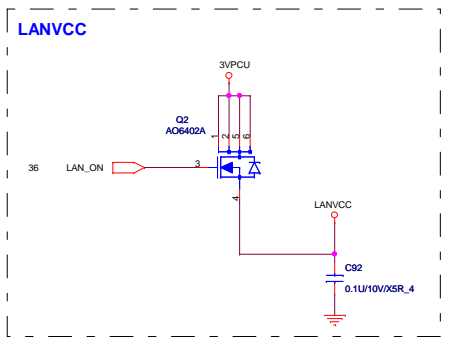

3.3V : Enable switching regulator
 0V : Disable switching regulator

* C5116 and C5273 are for U5006 EVDD12 pin 19.

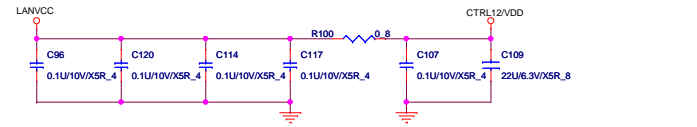

* C5110 to C5113 are for U5006 VDD33 pins-- 1, 29, 37 and 40.
 Place C5113, C5094 closed to U5006 pins 44, 45, and 40.

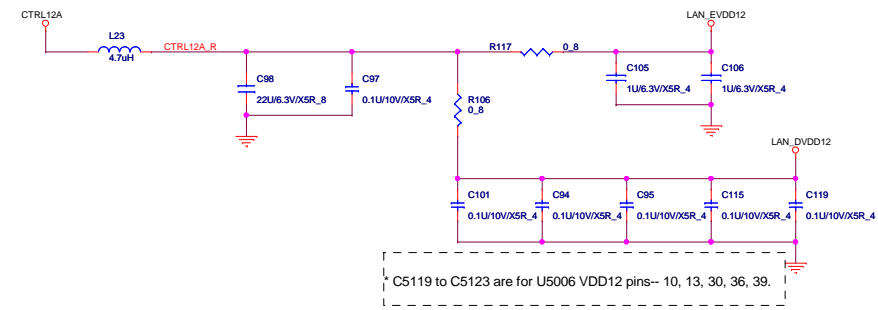

* C5119 to C5123 are for U5006 VDD12 pins-- 10, 13, 30, 36, 39.

Note 1: The Trace length between L1 and 8111DL's Pin 1 must be within 0.5 cm. C5 and C8 to L1 must be within 0.5cm. Refer to Layout guide for more detail.

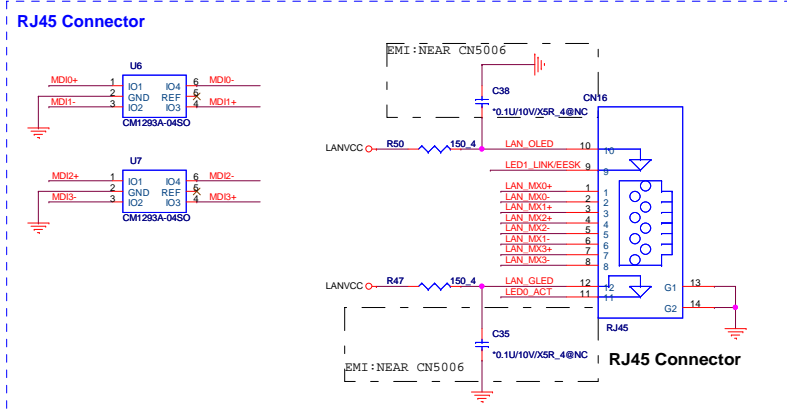
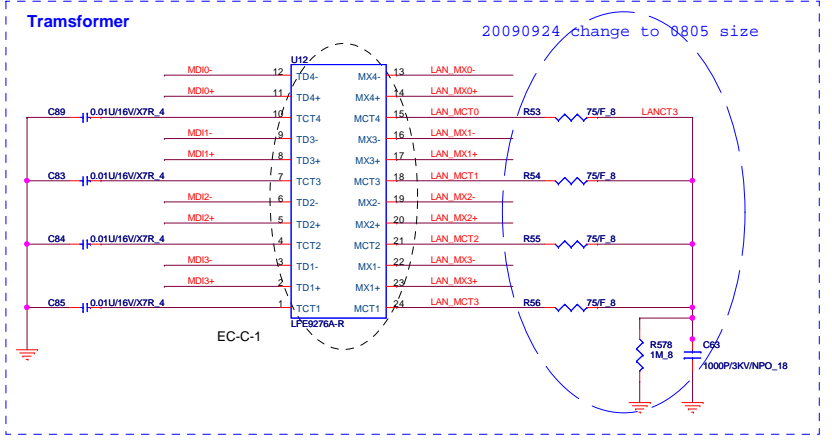

SATA Connector.

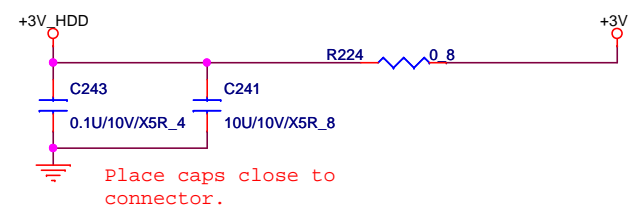
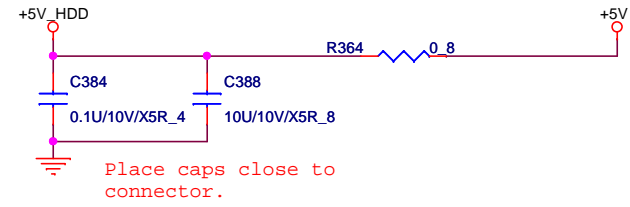
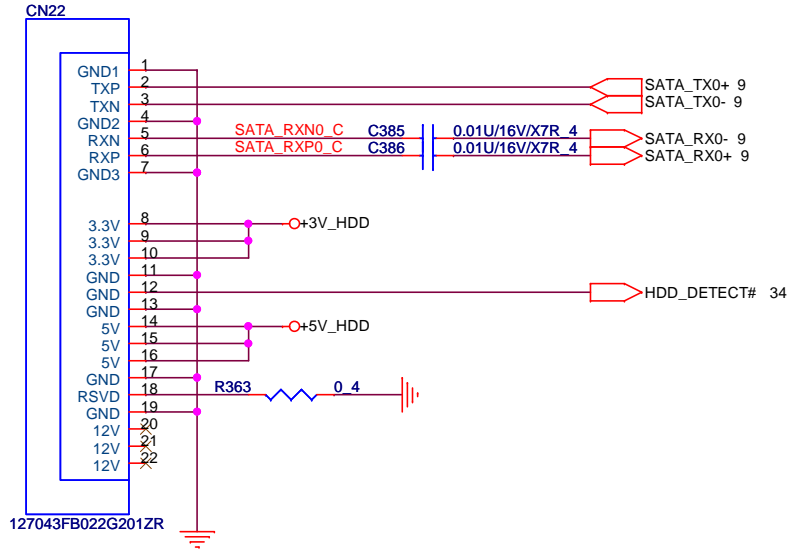
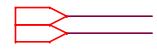

ODD Connector

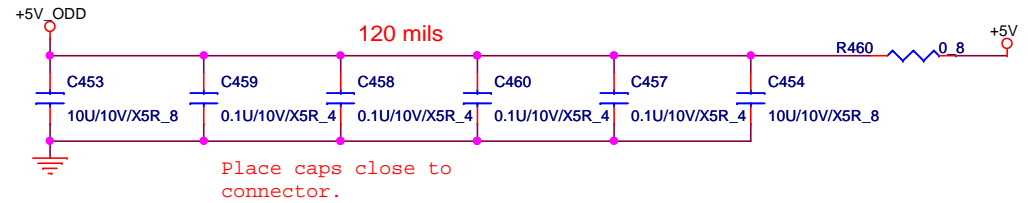
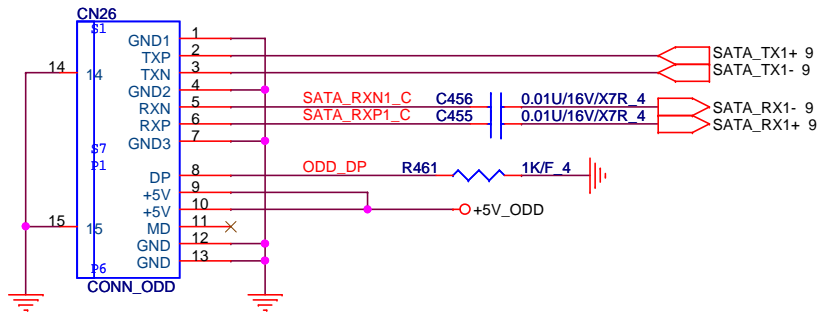

LD-Note Calpella UMA
Quanta Computer Inc.

Size Custom	Document Number SATA (HDD&CD_ROM)	Rev
Date: Saturday, November 07, 2009	Sheet 21	of 50

USBX1

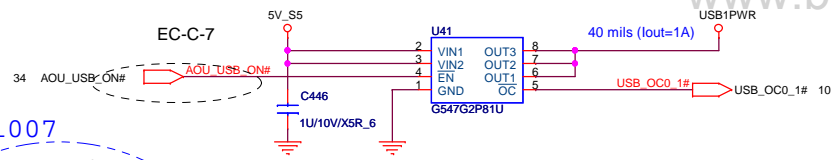

20091007

Support Black-berry function

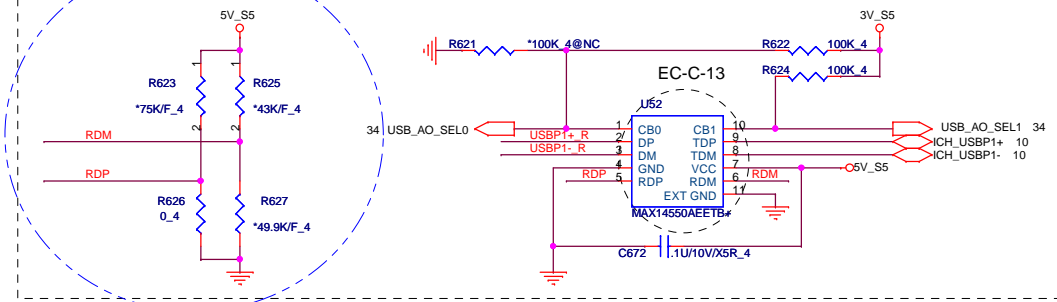

USB X1----> Wire to board conn

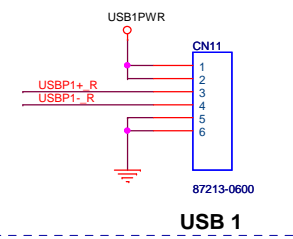

USB + E-SATA

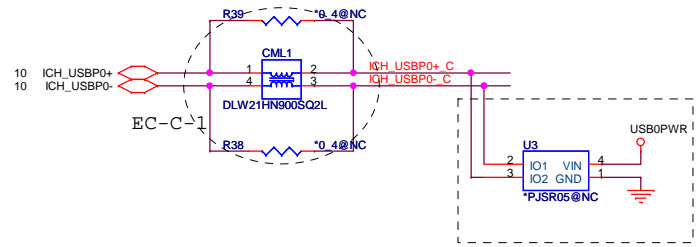
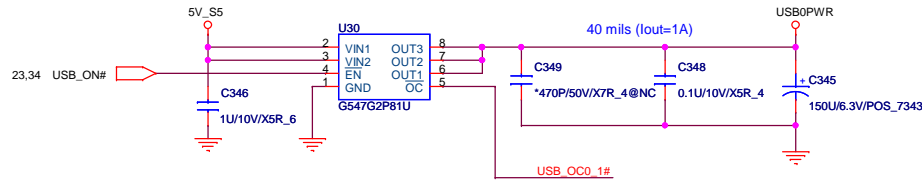

E-SATA RE-DRIVER

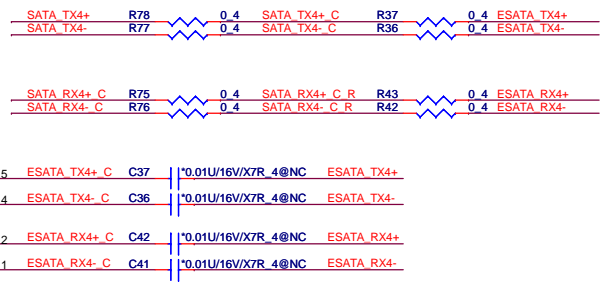
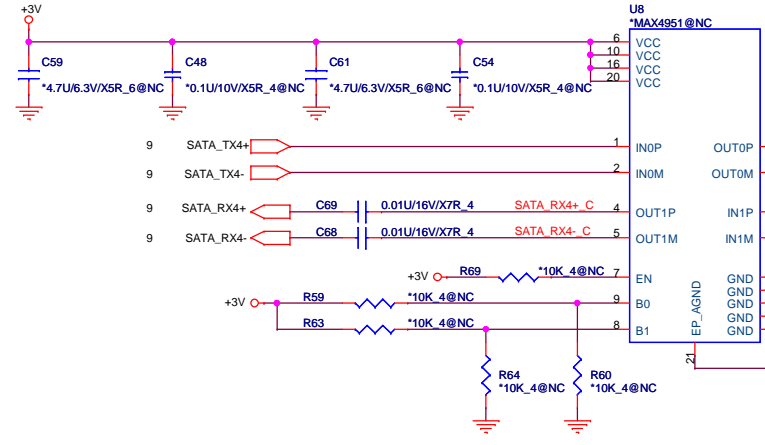

EN	B0	B1	FUNCTION
0	X	X	Standby
1	0	0	Standard SATA Output
1	1	0	Ch 0 Boost Output
1	0	1	Ch 1 Boost Output
1	1	1	Ch 0,1 Boost Output

USB 0

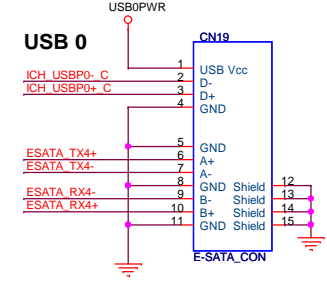

LD-Note Calpella UMA
Quanta Computer Inc.

Size: Custom Document Number: **USB X1/USB+ESATA** Rev: _____

Date: Sunday, November 08, 2009 Sheet: 22 of 50

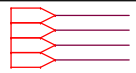

Finger Print

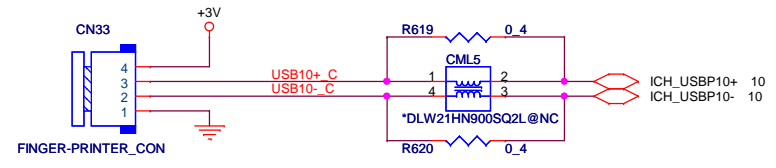

SIM Card CONN

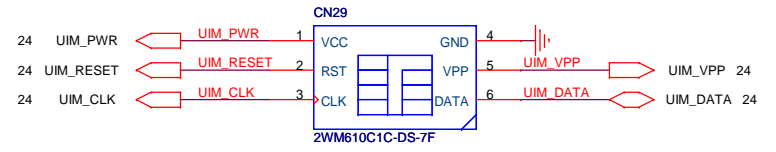

Layout Note:
UIM_RESET, UIM_CLK, UIM_DATA routing as short as possible

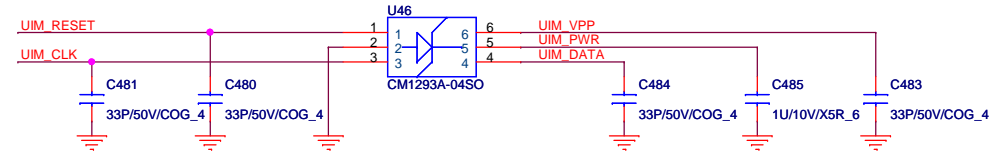

LOGO LED

20090928

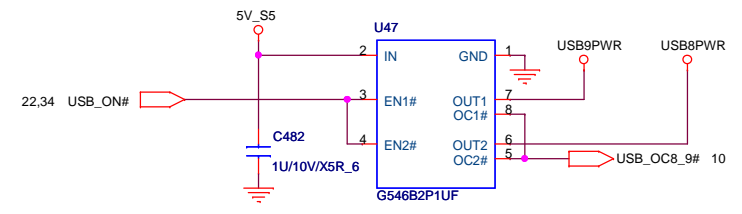
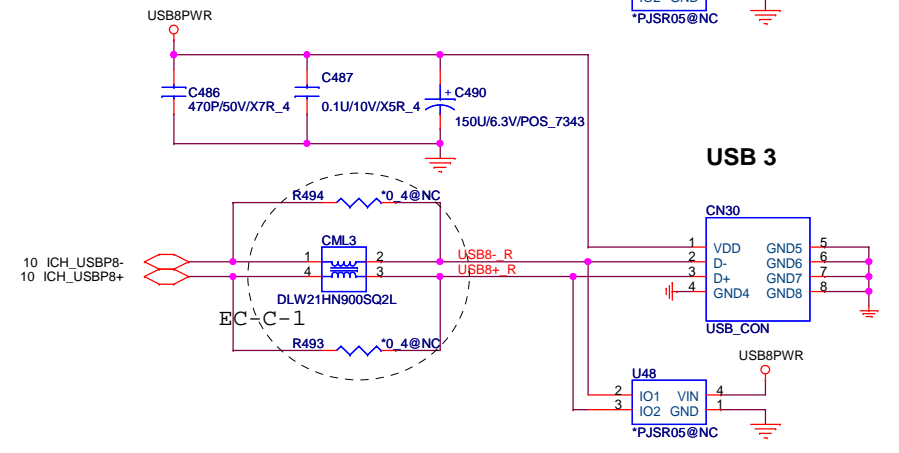
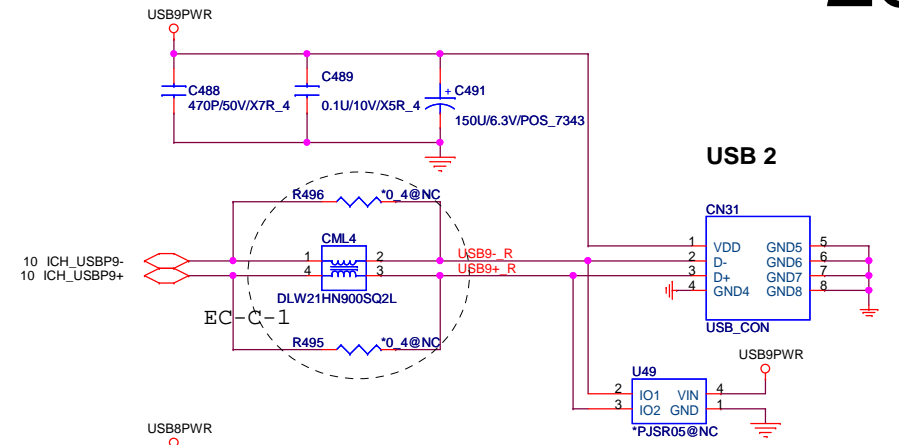

LD-Note Calpella UMA
Quanta Computer Inc.

Size	Document Number	Rev
Custom	USB X2/SIM_CARD/LEDs/RF	
Date:	Saturday, November 07, 2009	Sheet 23 of 50

MiniCard WWAN connector

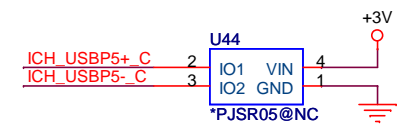
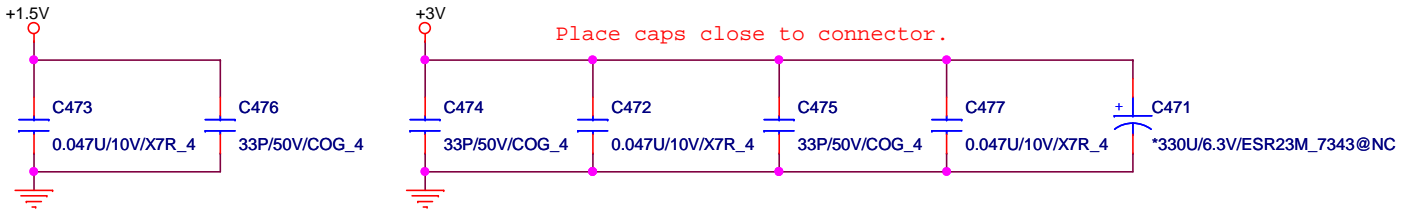
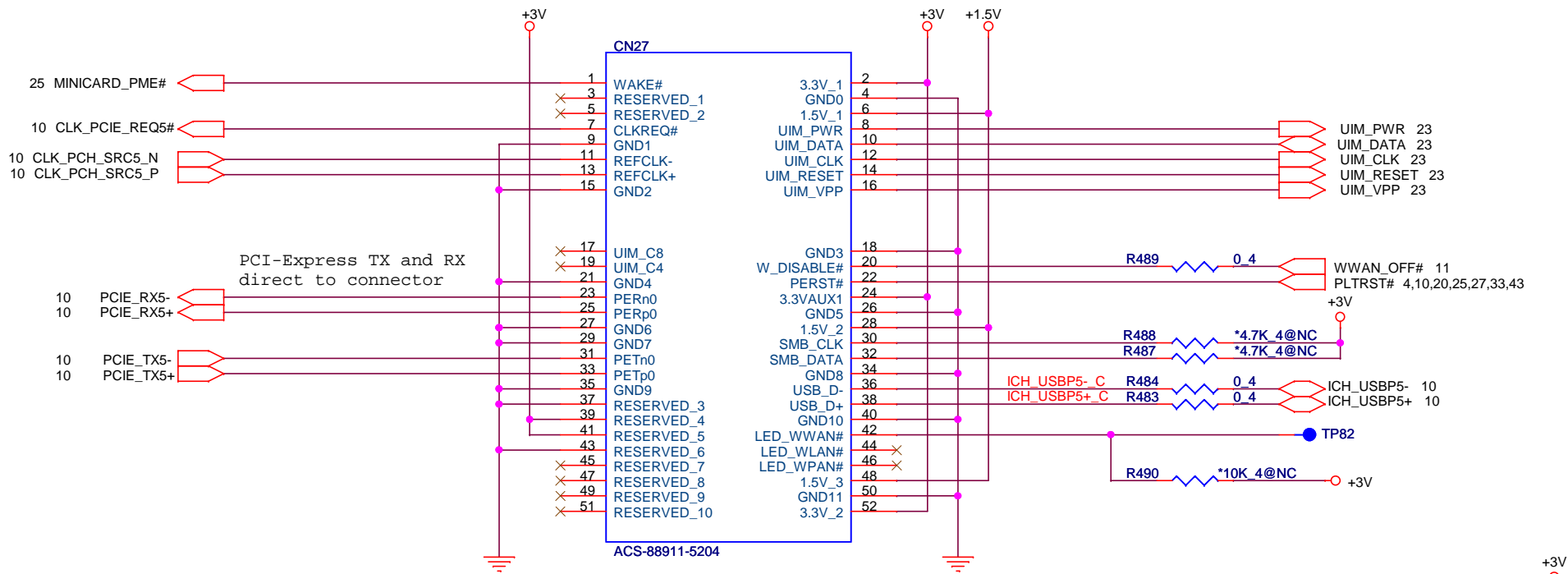



LD-Note Calpella UMA
Quanta Computer Inc.

Size Custom	Document Number MINI-Card (UWB, WWAN)	Rev
Date:	Saturday, November 07, 2009	Sheet 24 of 50

MiniCard WLAN/WiMAX connector

3V 4,8,9,10,11,12,14,15,16,17,18,19,20,21,22,23,24,27,29,30,31,33,34,36,38,39,40,41,43
 +3V 3,24,27,38
 +1.5V 9,16,20,28,32,34,36,37,40,42
 3VPCU 16,36,37,38,39,40,41,42
 VIN

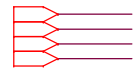

25

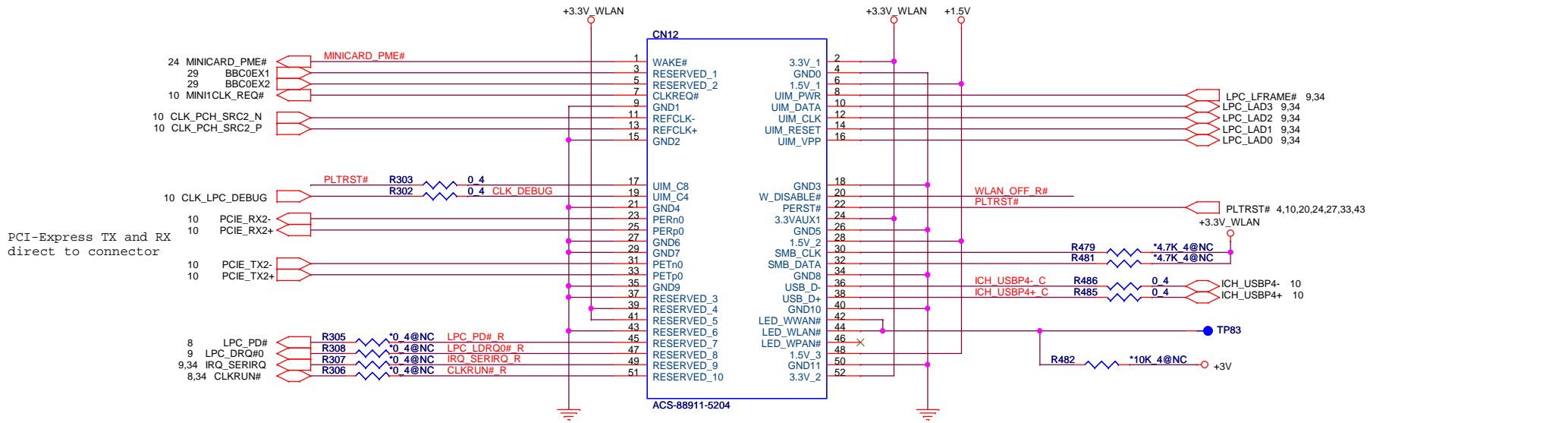

PCI-Express TX and RX direct to connector

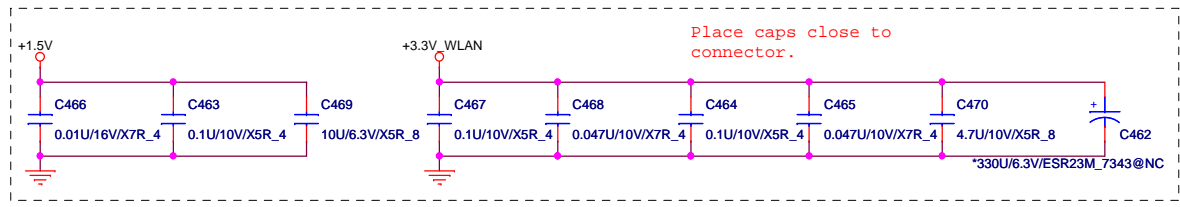
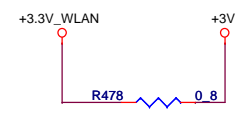
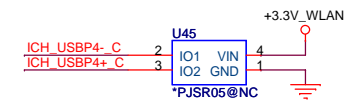
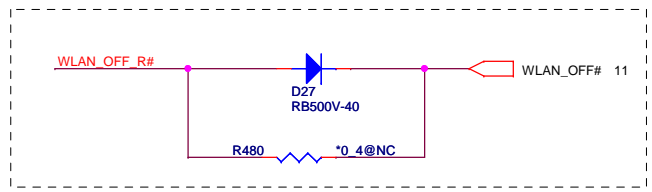
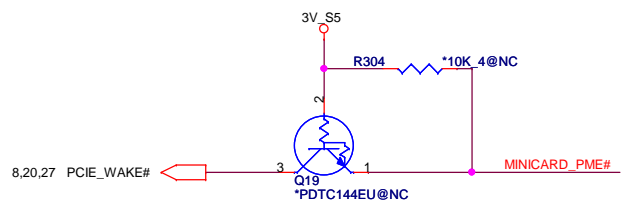

LD-Note Calpella UMA
Quanta Computer Inc.

Size Custom	Document Number MINI-Card (WLAN)	Rev
Date: Saturday, November 07, 2009		Sheet 25 of 50

Left NC if Pin23 connected to XD-D4

CARD READER

For external 12Mhz clock input pin13 floating
For external 48Mhz clock input pin13 pull high

Card Reader Model Select

Pin 45	R20
RTS5159-GR	0 ohm
RTS5158-GR	N.C

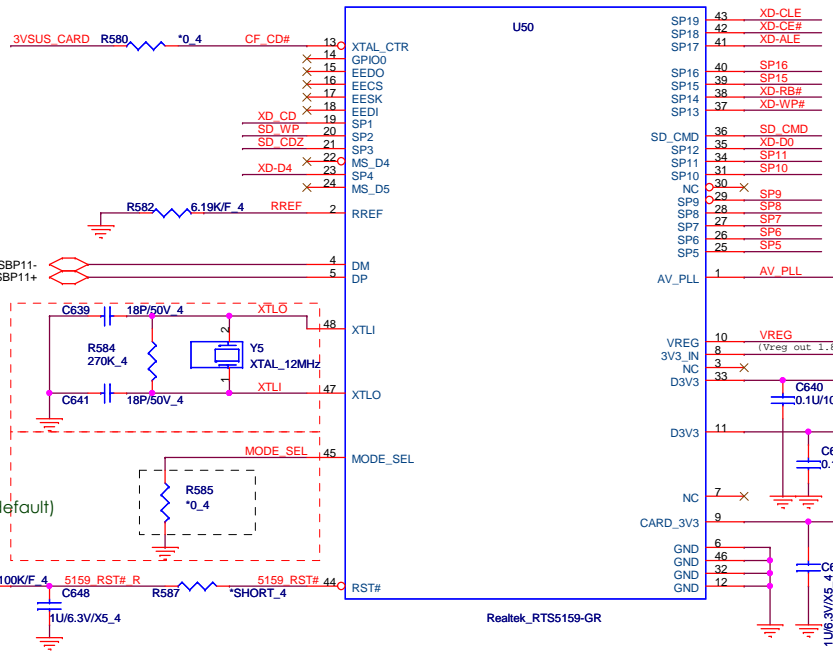

0515 EMI Changes

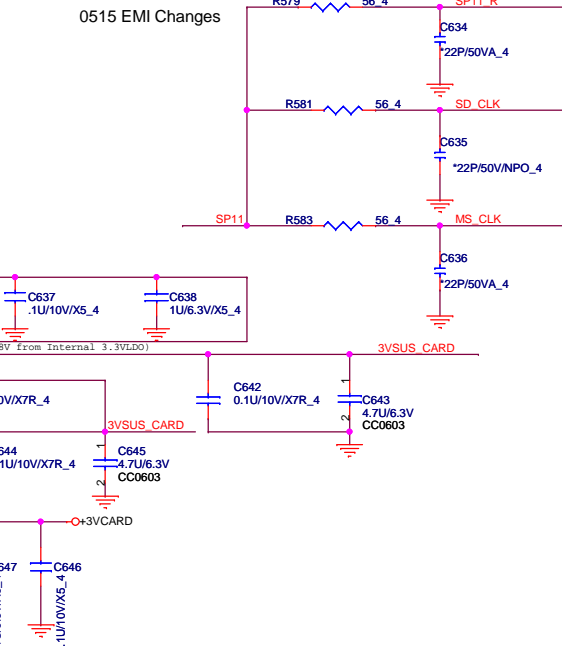

Note:

	SD/MMC	MS	XD
SP0			XD CD#
SP1	SD WP		XD D4
SP2	SD WP		XD D5
SP3	SD CD#		XD D6
SP4		MS BS	XD D7
SP5		MS D1	XD D8
SP6		MS D2	XD D9
SP7	SD DAT0	MS D0	XD D0
SP8	SD DAT1	MS D1	XD D1
SP9		MS INS#	
SP10	SD DAT6	MS D3	XD D7
SP11	SD CLK	MS SCLK	XD D1
SP12	SD DAT5		XD D0
SP13	SD DAT4		XD WP#
SP14		XD R/B#	
SP15	SD DAT3		XD WE#
SP16	SD DAT2		XD RE#
SP17		XD ALE	
SP18		XD CE#	
SP19		XD CLE	

7 in 1 Socket (MS, MS PRO, SD, MMC, xD...)

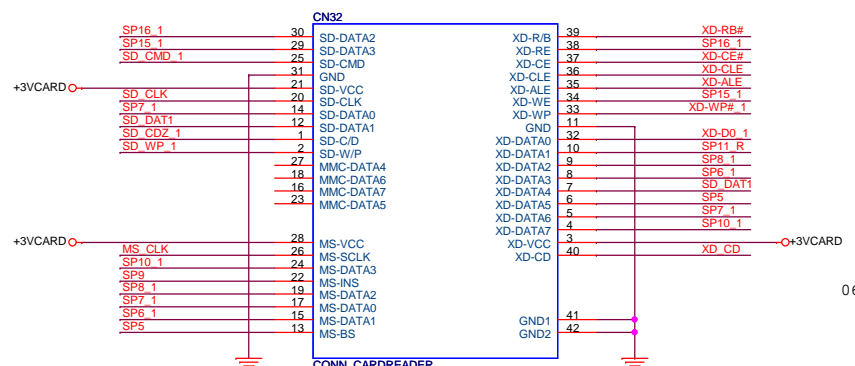

0616 Add 10K to GND for +3VCARD discharge in Ver.B

- SD WP R590 56.4 SD WP 1
- SD CDZ R591 56.4 SD CDZ 1
- SD CMD R592 56.4 SD CMD 1
- SP7 R593 56.4 SP7 1
- SP8 R594 56.4 SP8 1
- SP10 R595 56.4 SP10 1
- XD-D4 R596 56.4 SD DAT1
- XD-D0 R597 56.4 XD-D0 1
- XD-WP# R598 56.4 XD-WP# 1
- SP15 R599 56.4 SP15 1
- SP16 R600 56.4 SP16 1
- SP6 R601 56.4 SP6 1

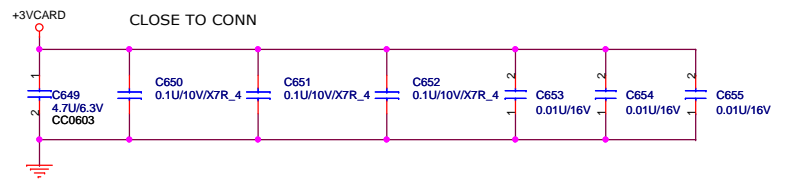

Express Card

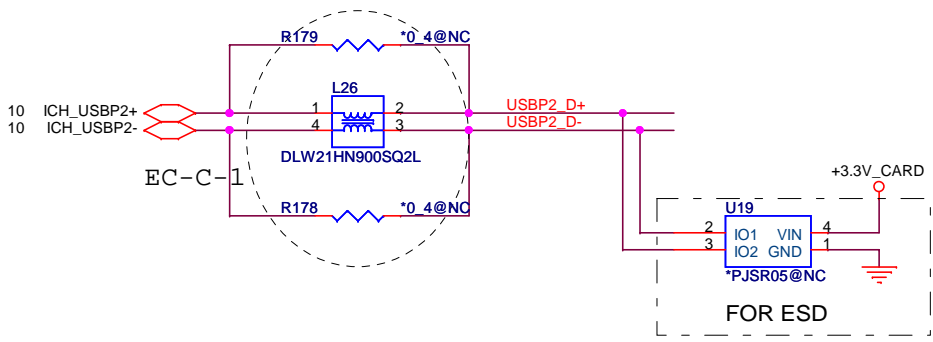

+1.5V_CARD Max. 650mA, Average 500mA.
+3V_CARD Max. 1300mA, Average 1000mA.

20090928
avoid current leakage

4,10,20,24,25,33,43 PLTRST#

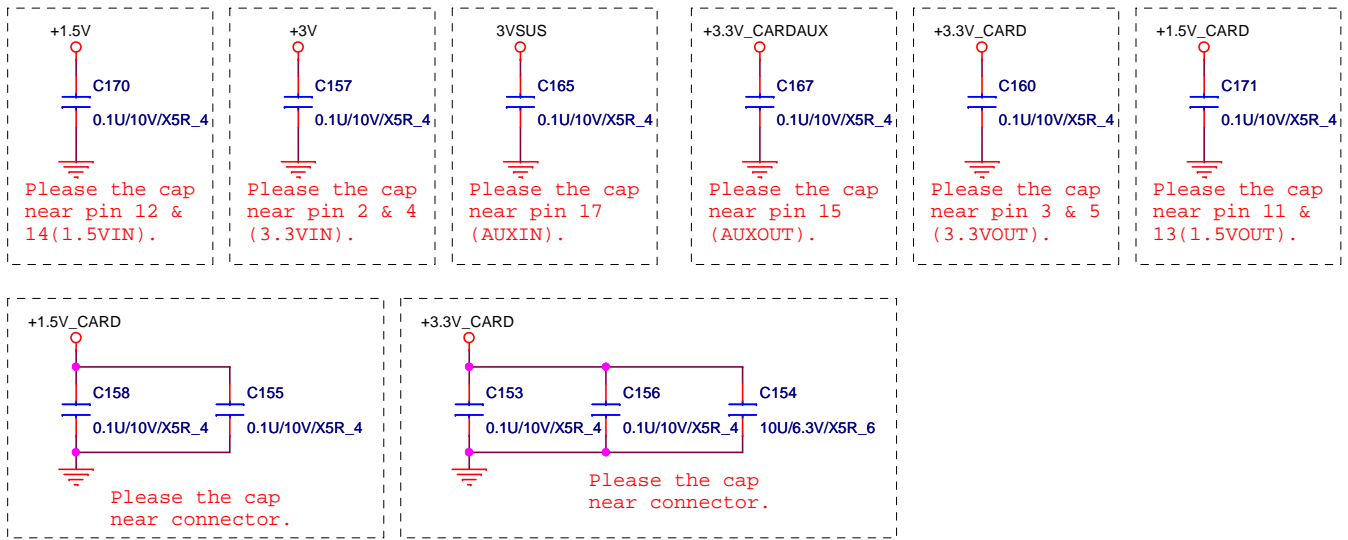
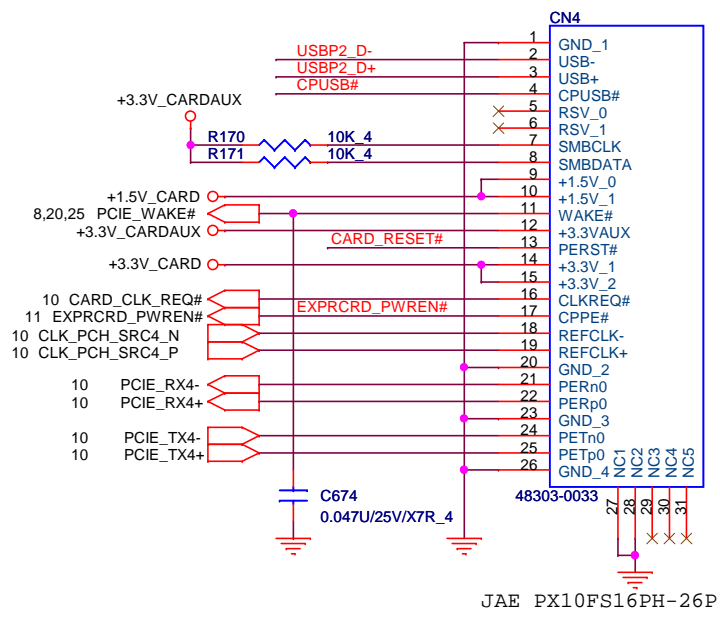
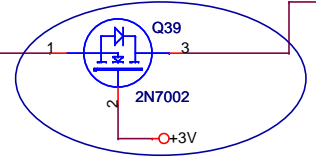
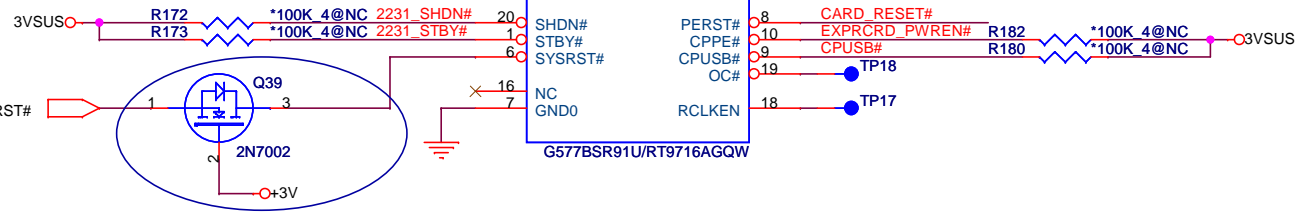



LD-Note Calpella UMA
Quanta Computer Inc.

Size Custom	Document Number Express Card	Rev
Date: Saturday, November 07, 2009		Sheet 27 of 50

KEYBOARD connector

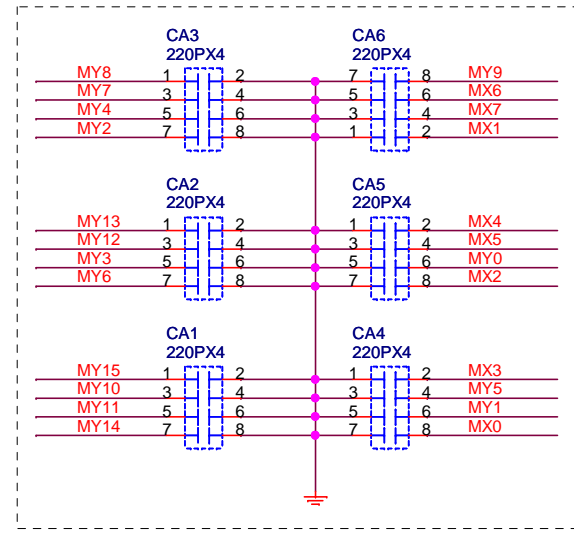
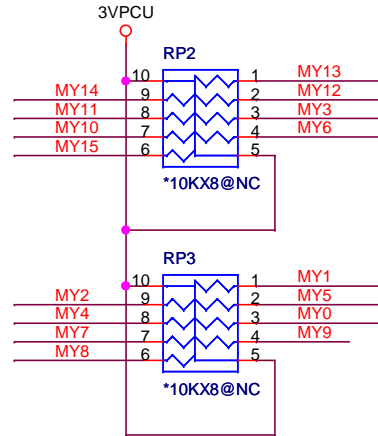
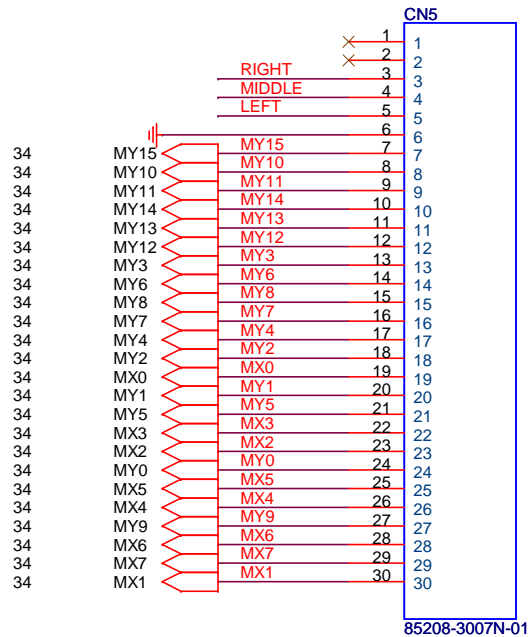

Touch pad

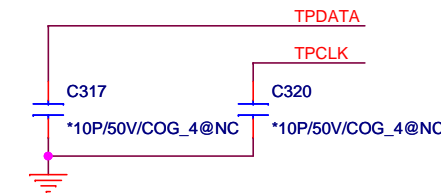
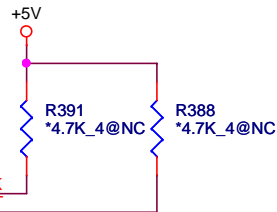
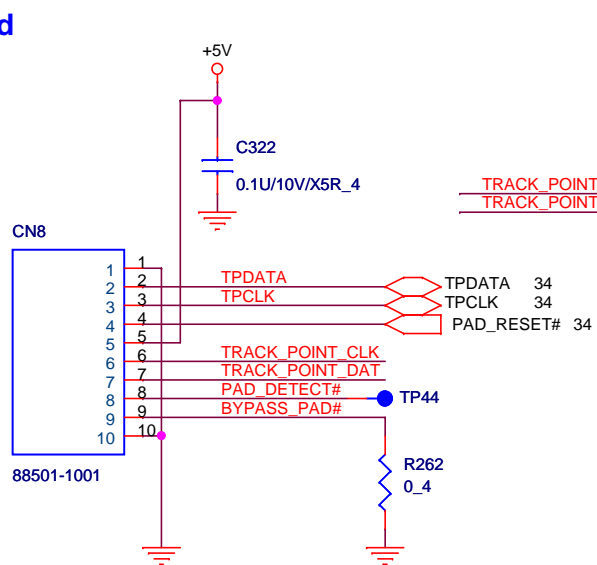

Place C5303 ,C5302 closed to CN5020

TRACK POINT

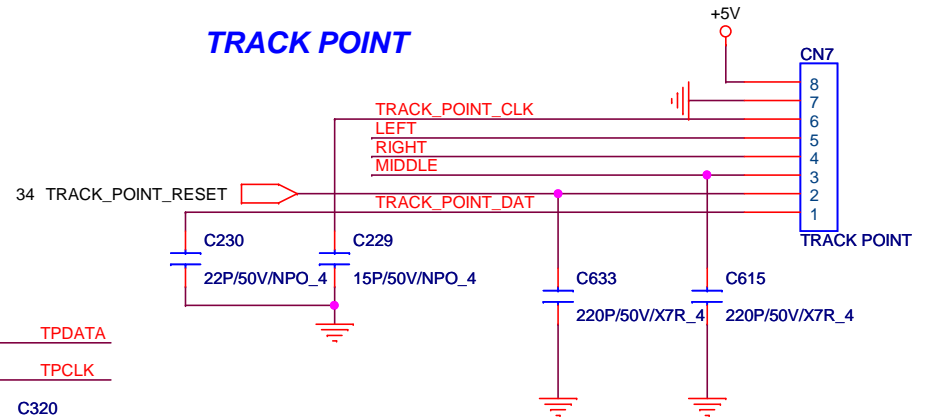

LD-Note Calpella UMA
Quanta Computer Inc.

Size Custom	Document Number K/B, T/P	Rev
Date: Saturday, November 07, 2009	Sheet 28 of 50	Rev

BLUETOOTH

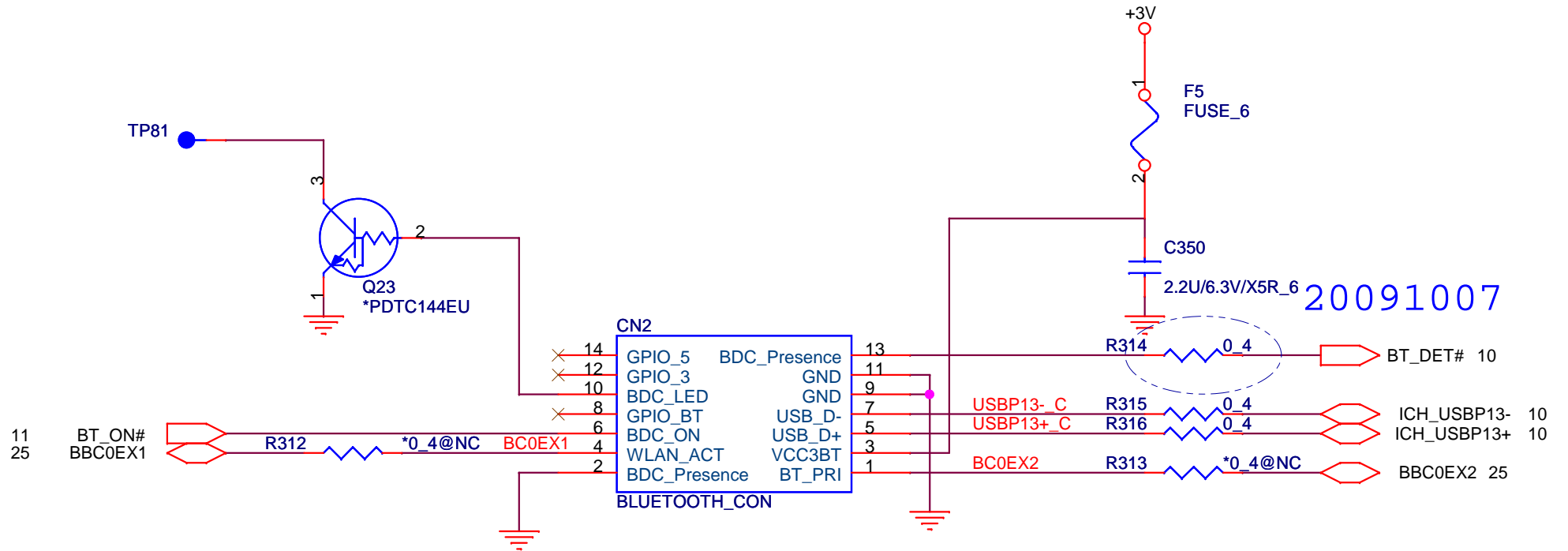

LD-Note Calpella UMA
Quanta Computer Inc.

Size Custom	Document Number B/T	Rev
Date: Saturday, November 07, 2009	Sheet 29 of 50	

FAN CONTROL

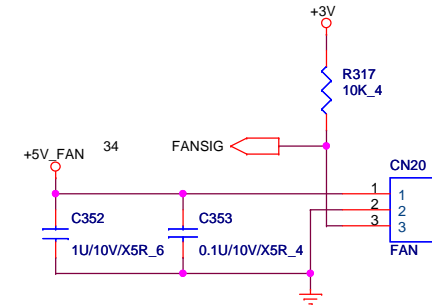
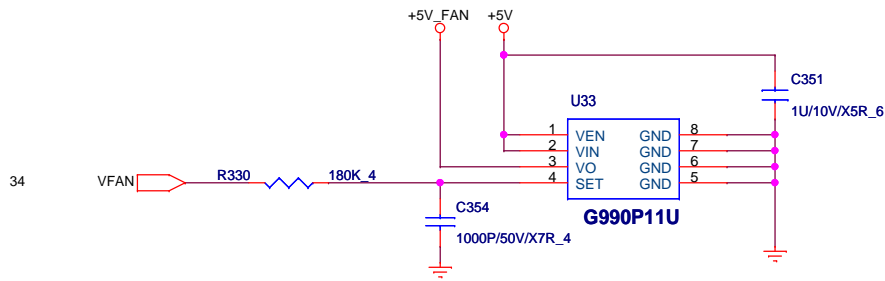

EC-C-9

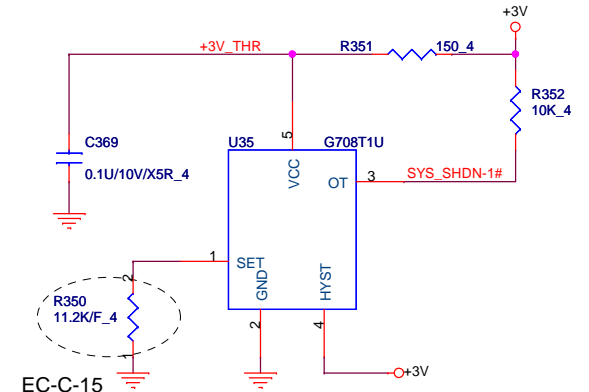
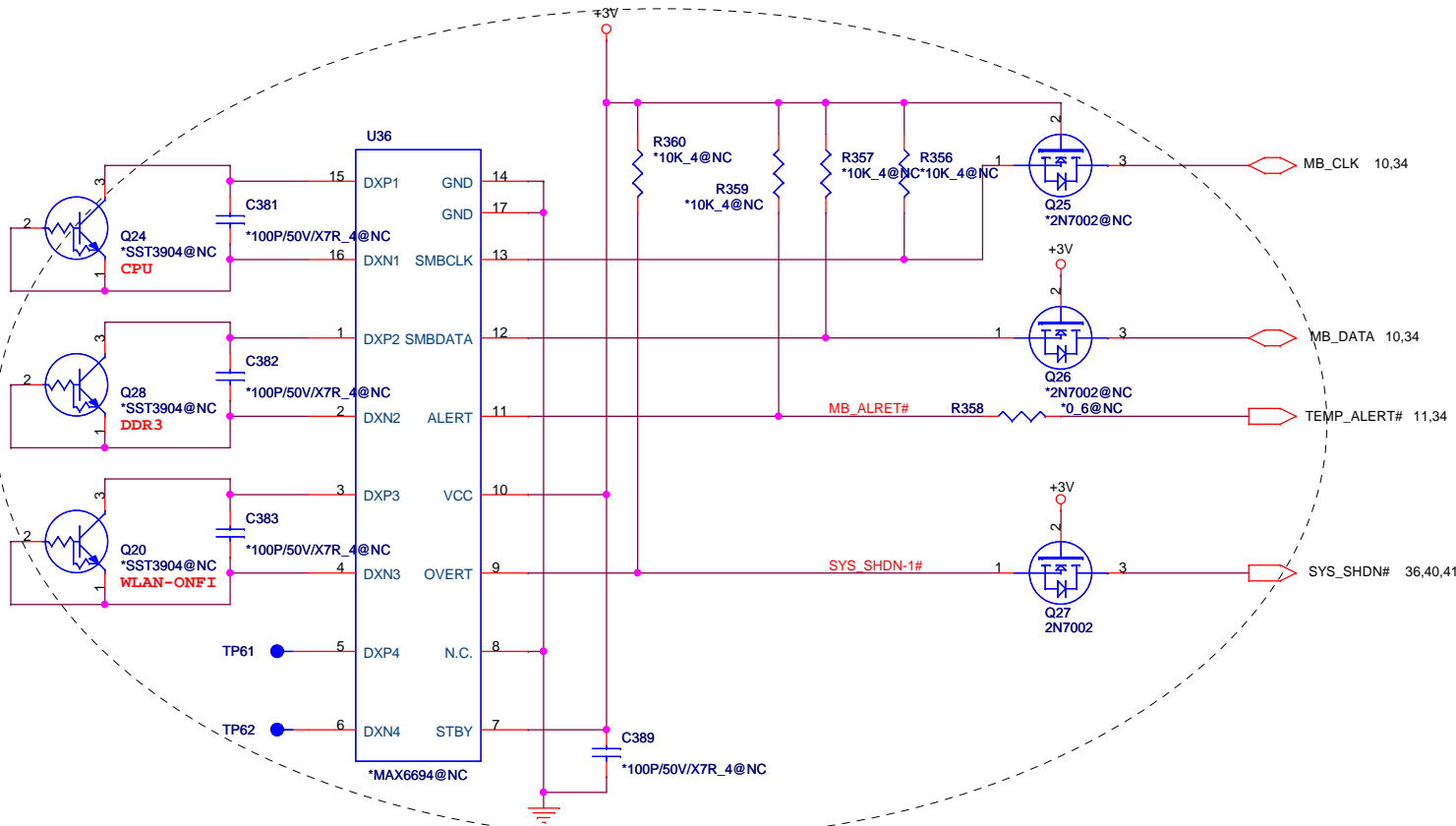



LD-Note Calpella UMA
Quanta Computer Inc.

Size Custom	Document Number FAN & THERMAL	Rev
Date: Saturday, November 07, 2009		Sheet 30 of 50

G-SENSOR (2-Axial)

www.buifanxiu.com

+3V
+15V

31

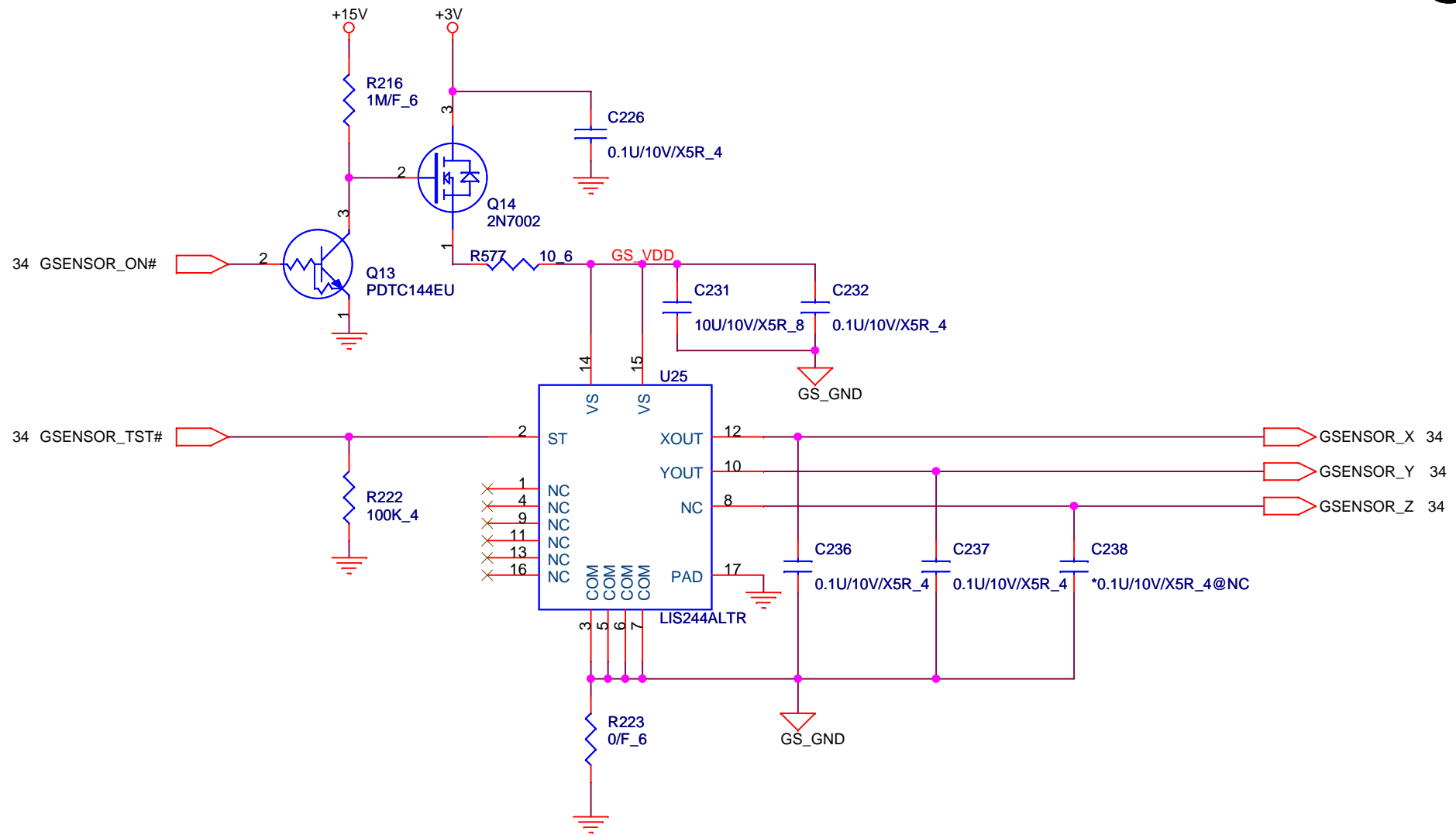

LD-Note Calpella UMA
Quanta Computer Inc.

Size Custom	Document Number G-SENSOR	Rev
Date: Saturday, November 07, 2009	Sheet 31 of 50	

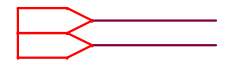

20080928

FFC TO B LED RIGHT SIDE CONNECTOR

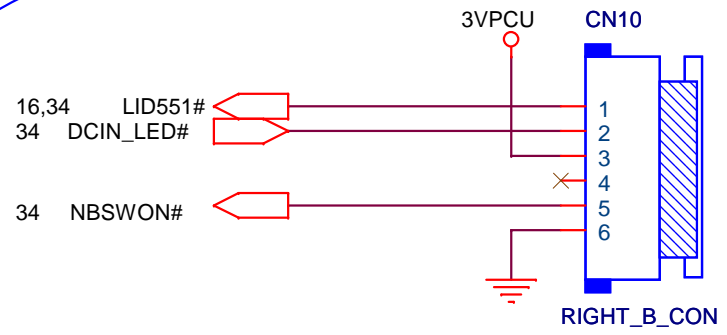

20081002

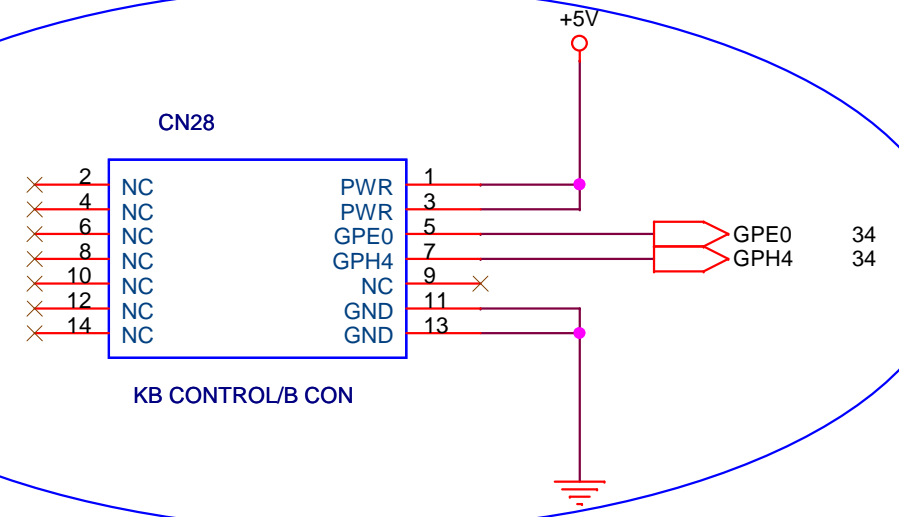

LD-Note Calpella UMA
Quanta Computer Inc.

Size Custom	Document Number B TO B CON	Rev
Date: Saturday, November 07, 2009	Sheet 32 of 50	

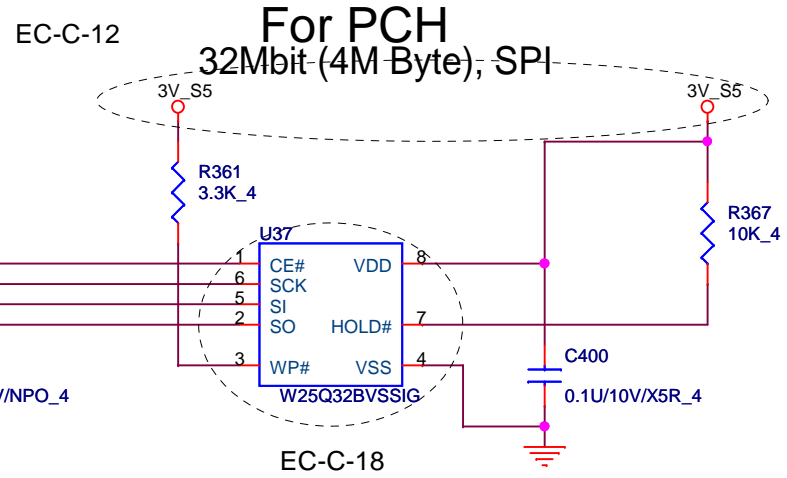
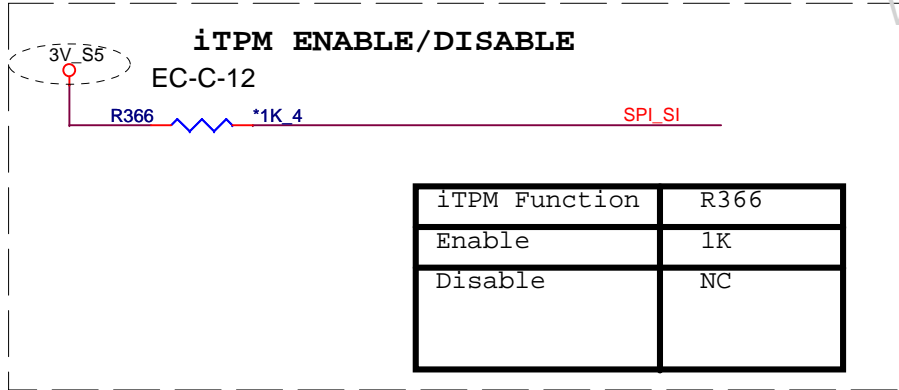

RFID

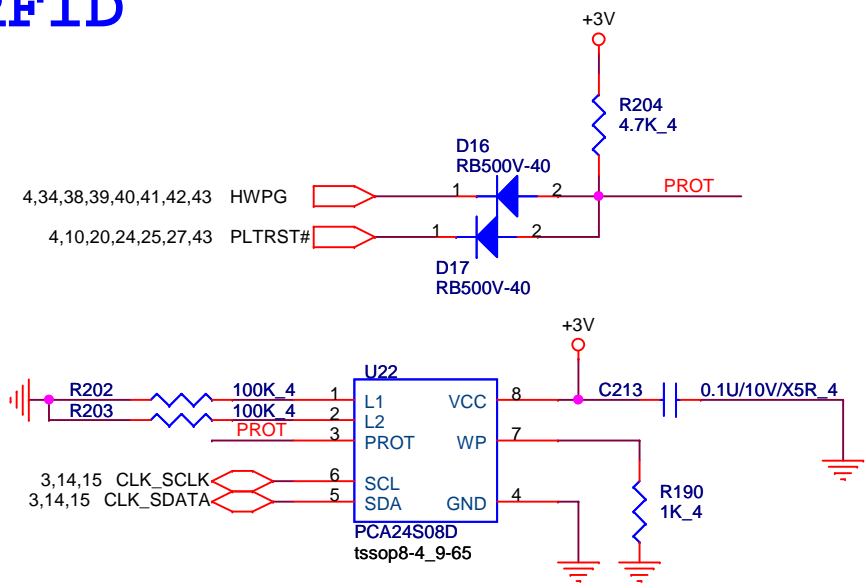

LD-Note Calpella UMA
Quanta Computer Inc.

Size Custom	Document Number iTPM & RFID EEPROM	Rev
Date: Saturday, November 07, 2009	Sheet 33 of 50	

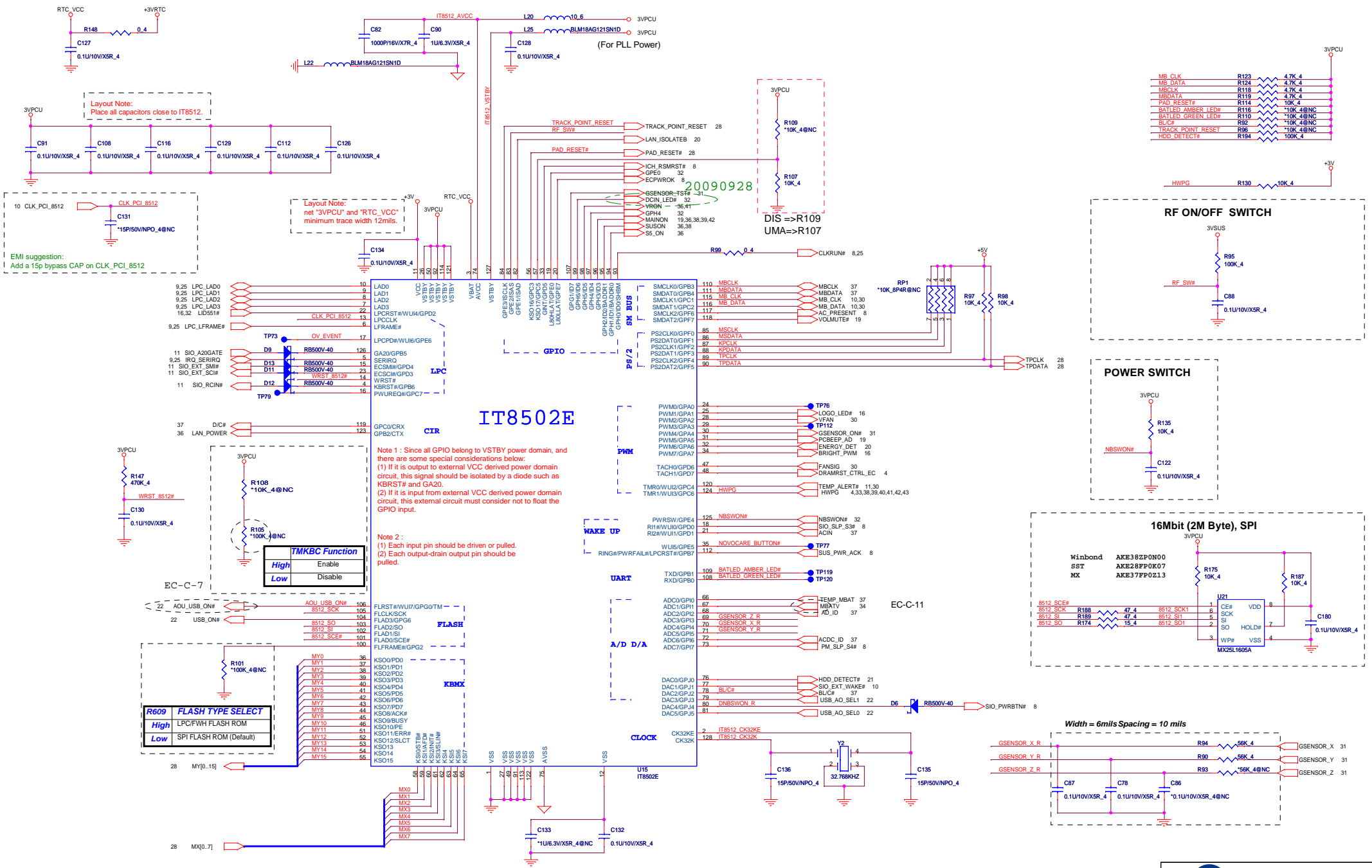

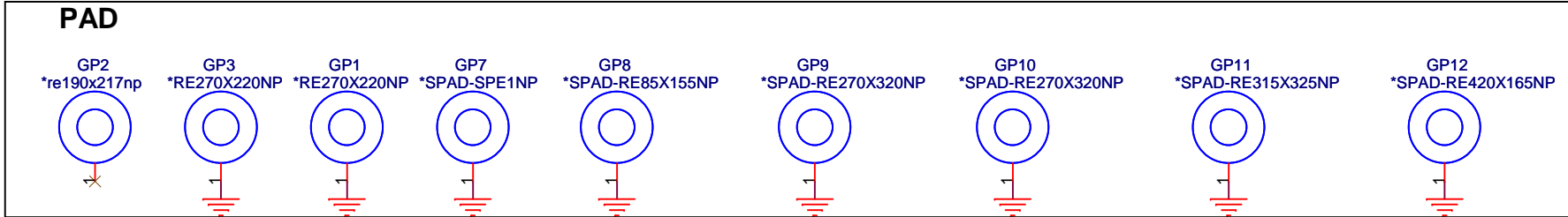
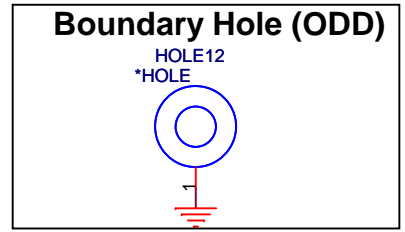
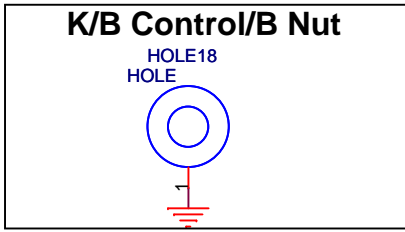
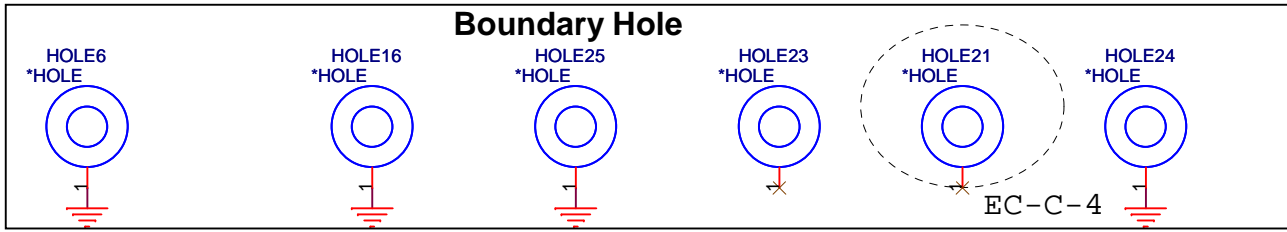
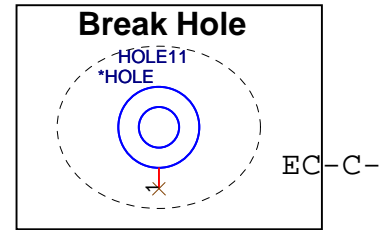
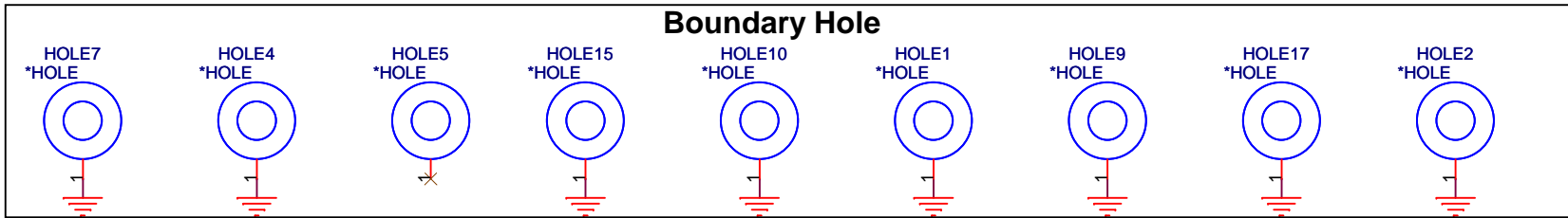
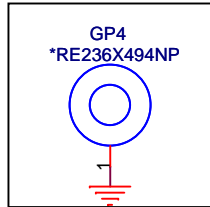
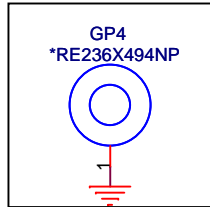
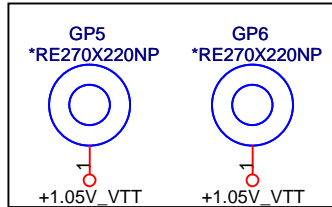
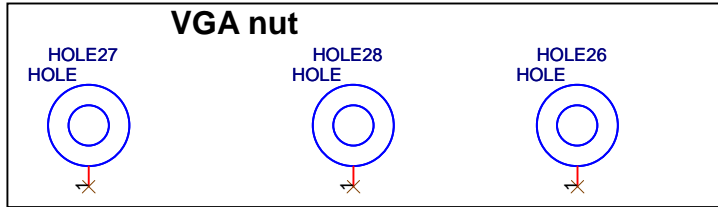
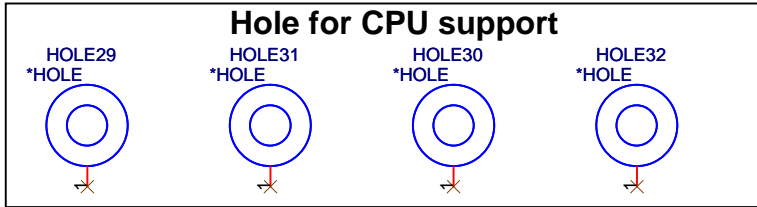
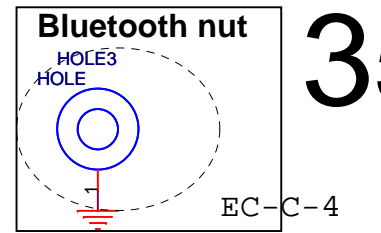
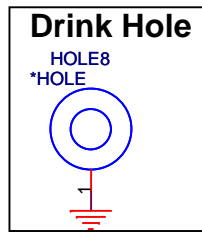
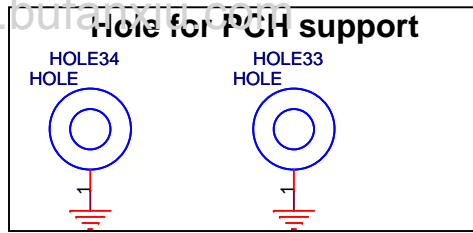
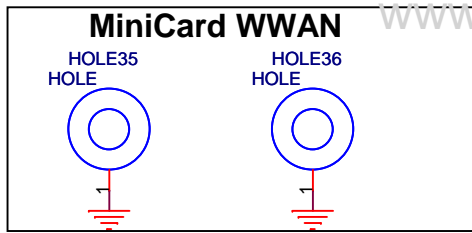
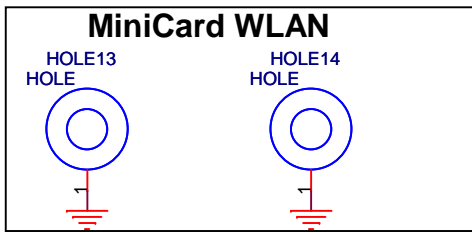

LD-Note Calpella UMA
Quanta Computer Inc.

Size Custom	Document Number HOLD & SKEW	Rev
Date: Saturday, November 07, 2009	Sheet 35 of 50	Rev 1

+3.3V, +5V

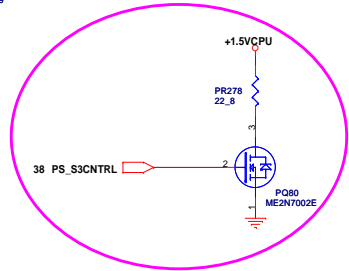
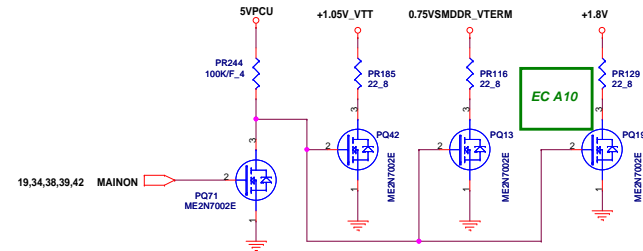
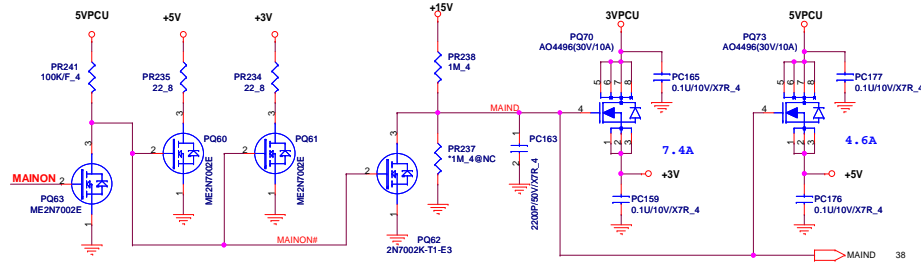

3V_S5, 5V_S5

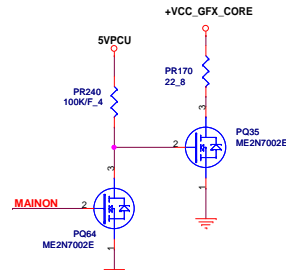
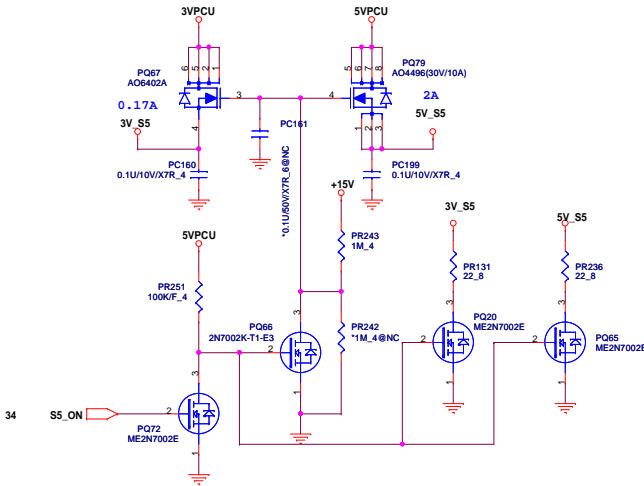

LANVCC

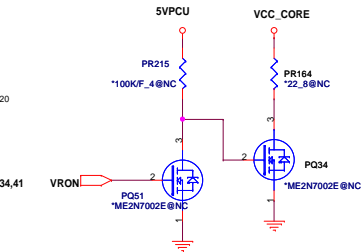
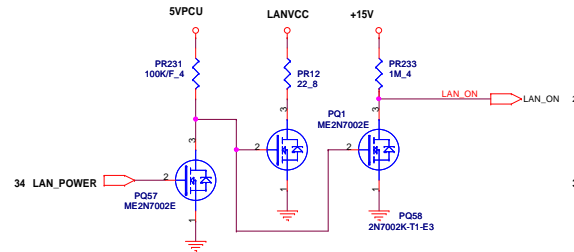

3VSUS, 5VSUS

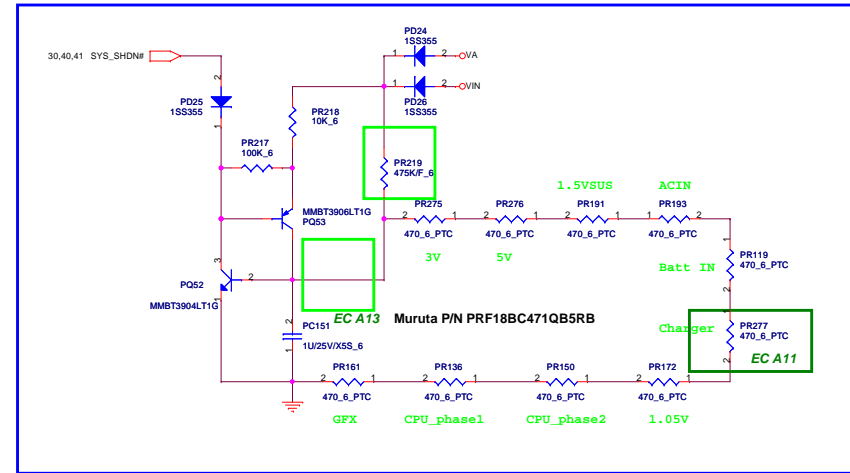
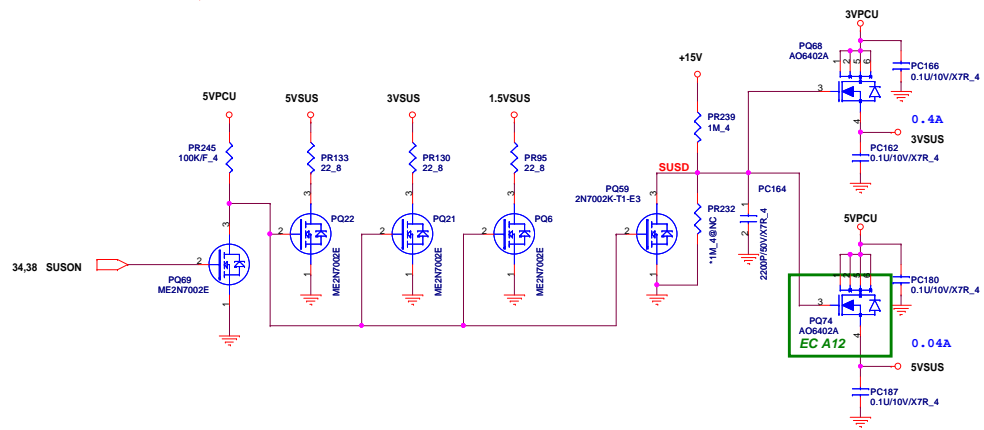

R138=0.02m ohm for 65W adapter-->current limit is 3A

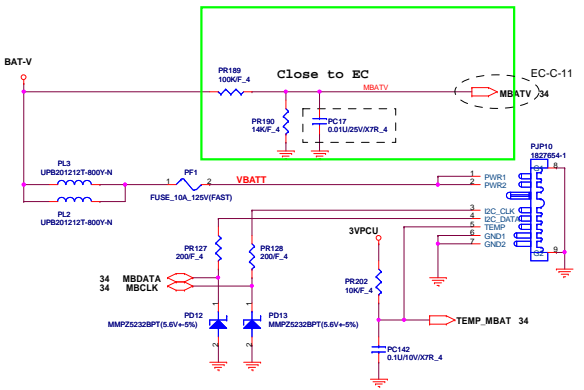
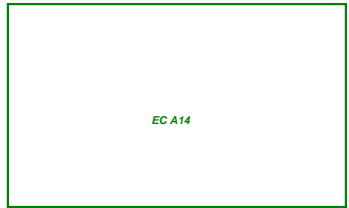
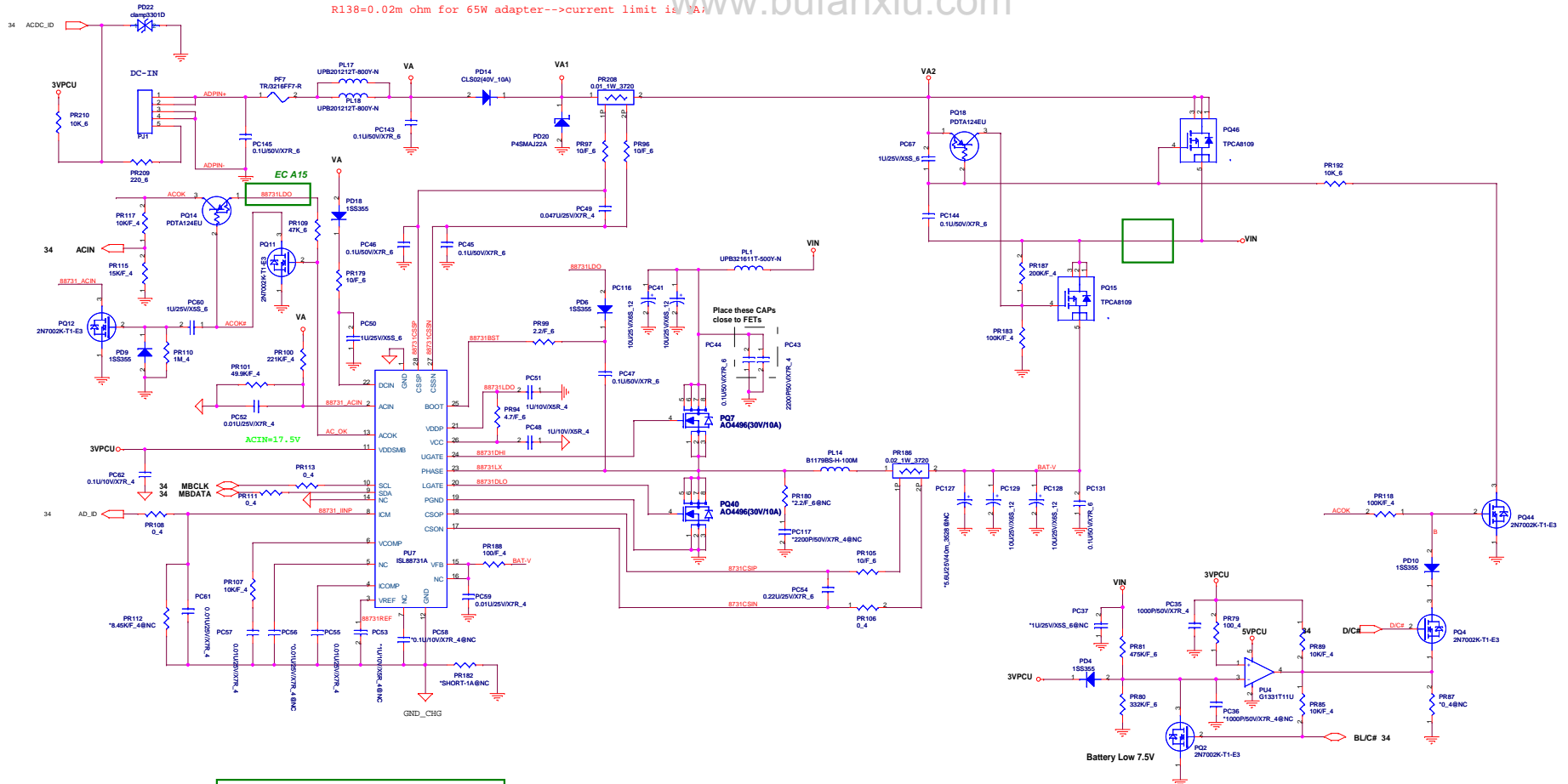

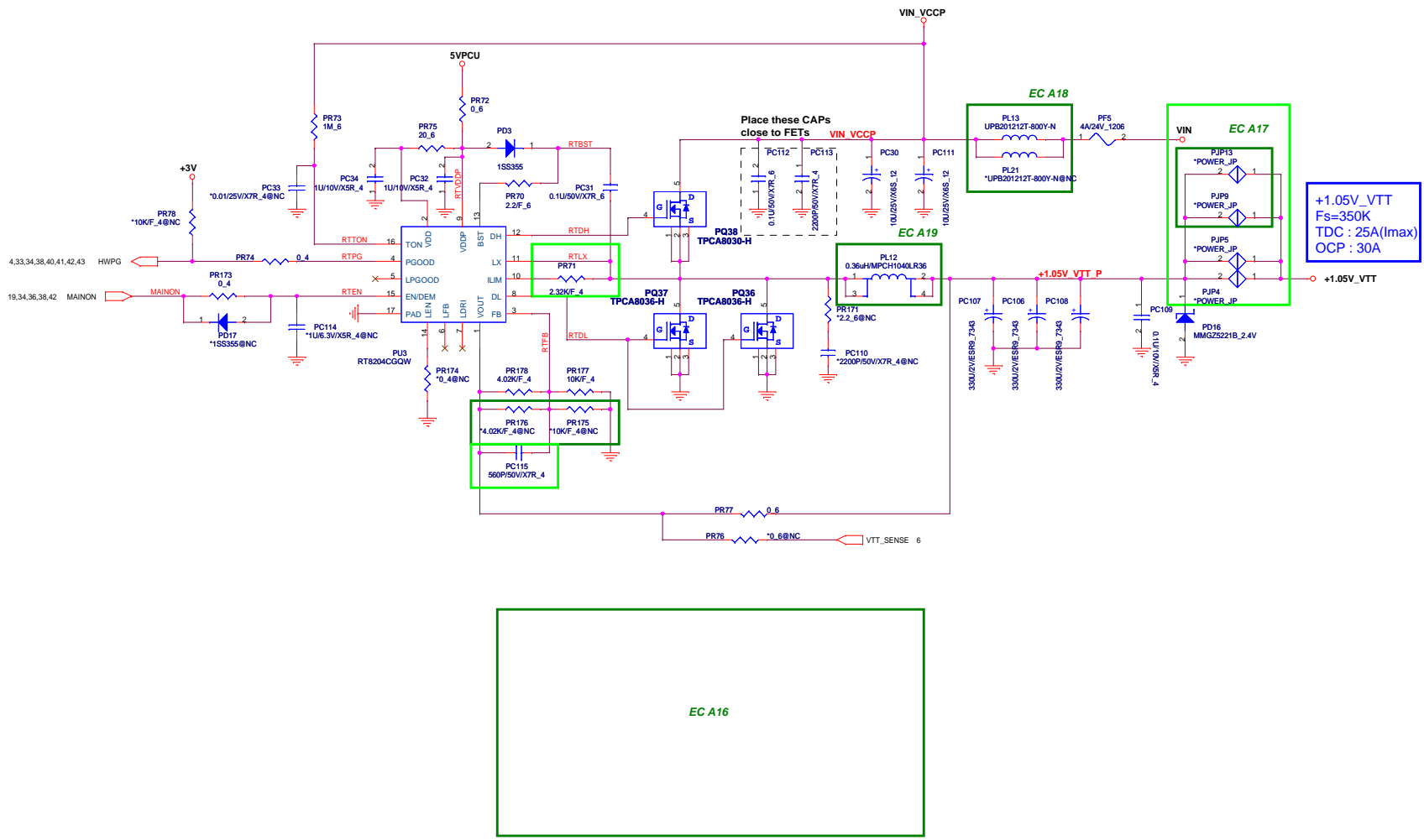

+1.05V_VTT
 $F_s=350K$
 $TDC: 25A(I_{max})$
 $OCP: 30A$

9,16,20,28,32,34,36,37,42	3VPCU
36,37,38,39,42	5VPCU
16,31,36,38	+15V
16,36,37,38,39,41,42	VIN

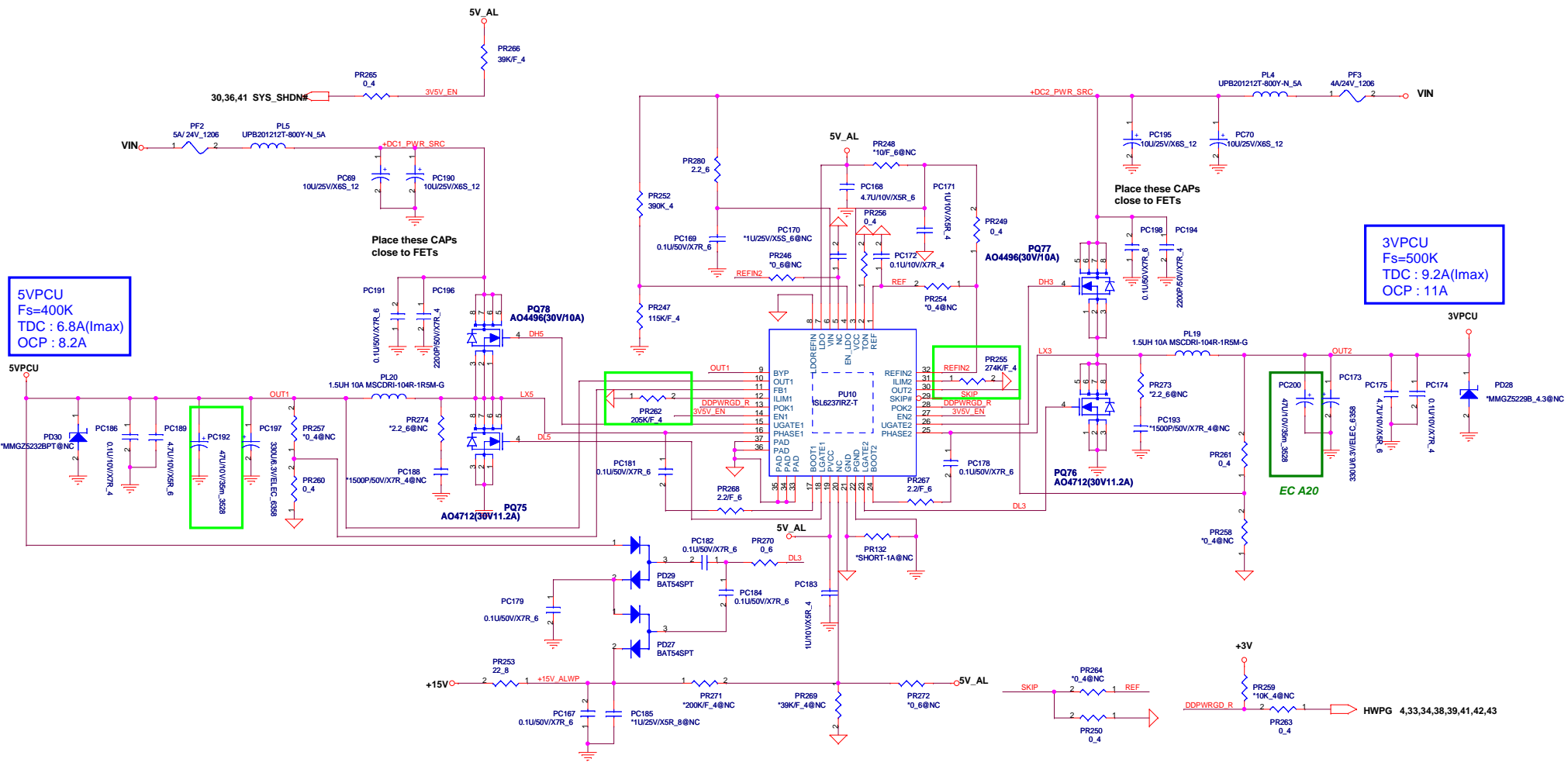

5VPCU
Fs=400K
TDC : 6.8A(I_{max})
OCP : 8.2A

3VPCU
Fs=500K
TDC : 9.2A(I_{max})
OCP : 11A

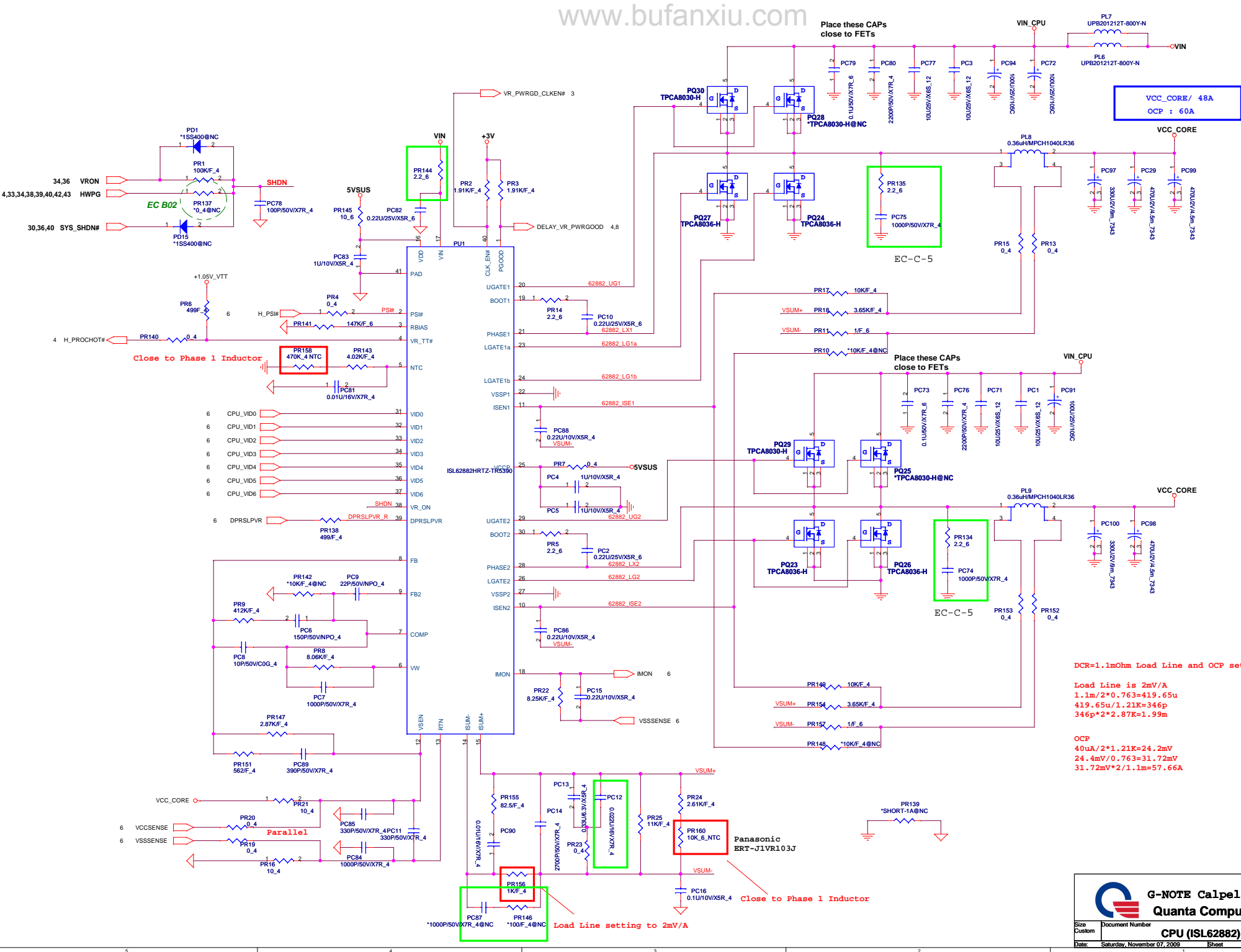

DCR=1.1mOhm Load Line and OCP setting

Load Line is 2mV/A
 $1.1m/2 * 0.763 = 419.65u$
 $419.65u/1.21K = 346p$
 $346p * 2 * 2.87K = 1.99m$

OCP
 $40uA/2 * 1.21K = 24.2mV$
 $24.4mV/0.763 = 31.72mV$
 $31.72mV * 2 / 1.1m = 57.66A$

G-NOTE Calpella (UMA)
Quanta Computer Inc.

Size: Custom Document Number: **CPU (ISL62882)** Rev: 1B

Date: Saturday, November 07, 2009 Sheet: 41 of 50

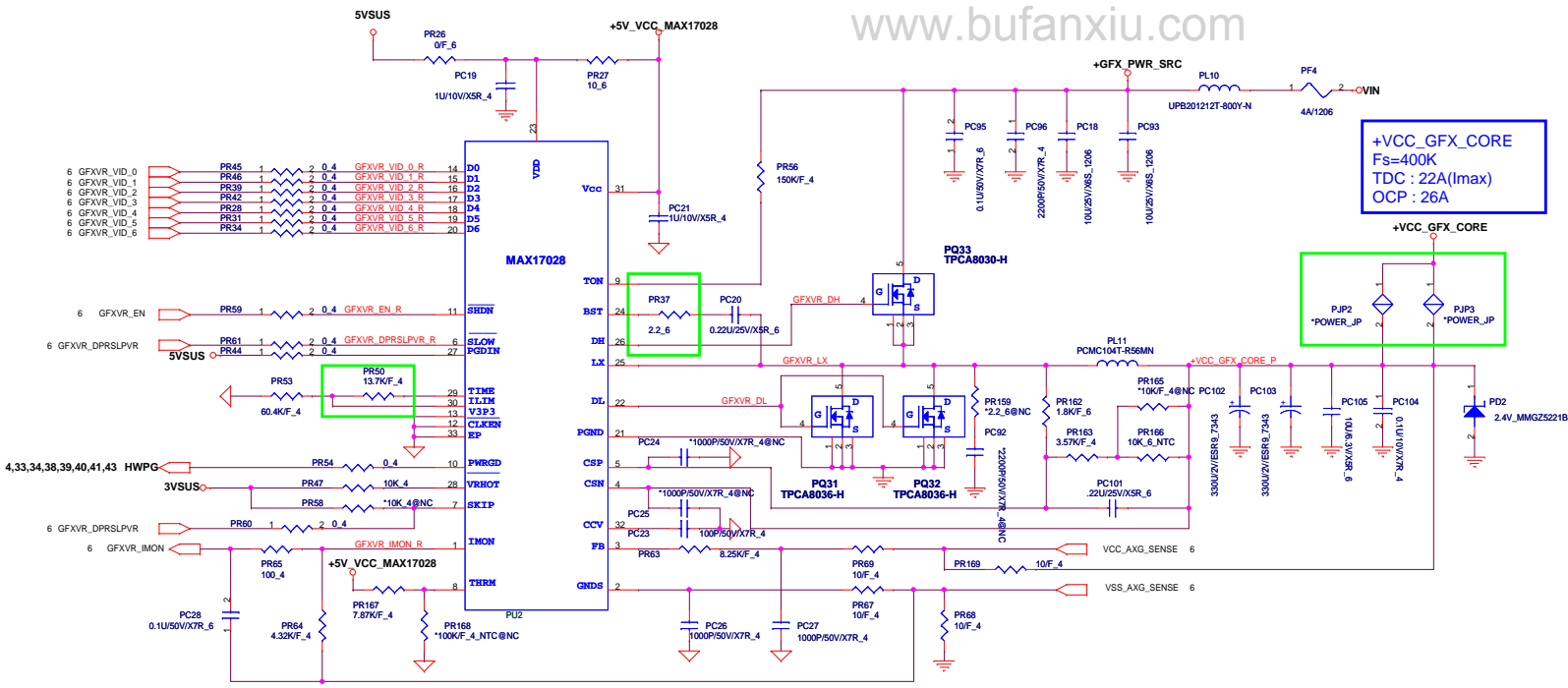

+VCC_GFX_CORE
 Fs=400K
 TDC : 22A(I_{max})
 OCP : 26A

+VCC_GFX_CORE
 *PJP2 *POWER_IP
 *PJP3 *POWER_IP

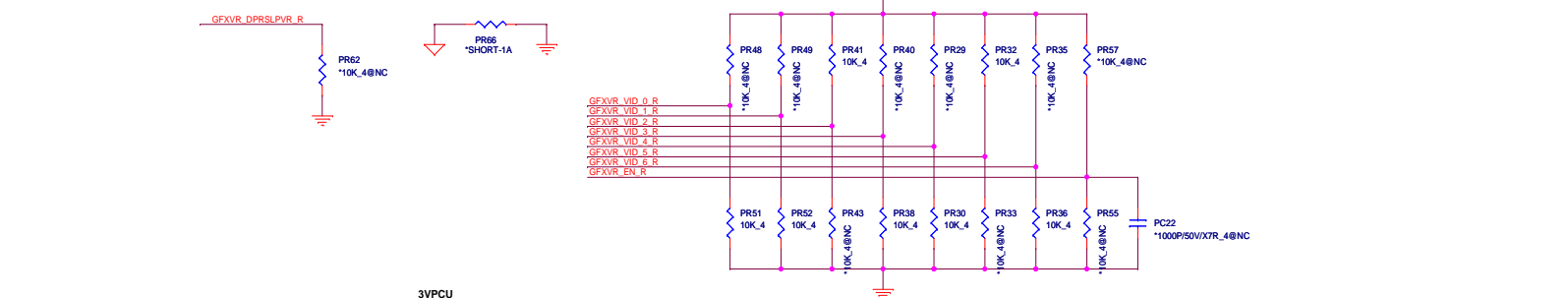

+1.8V
 TDC : 1A(I_{max})

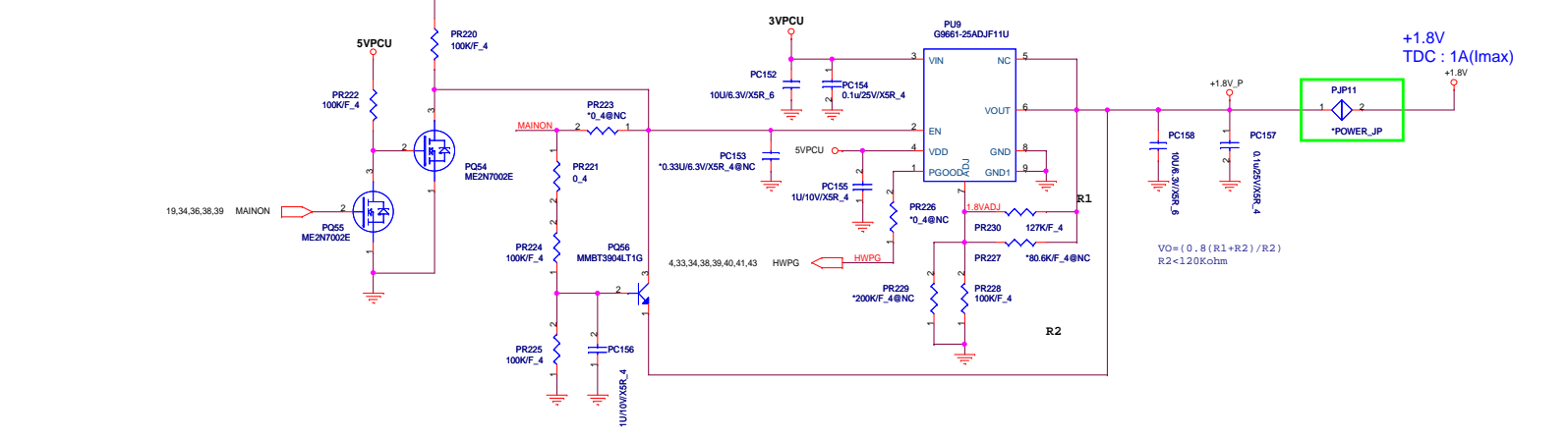

+1.8V
 TDC : 1A(I_{max})

$V_O = (0.8(R1+R2) / R2)$
 $R2 < 120k\Omega$

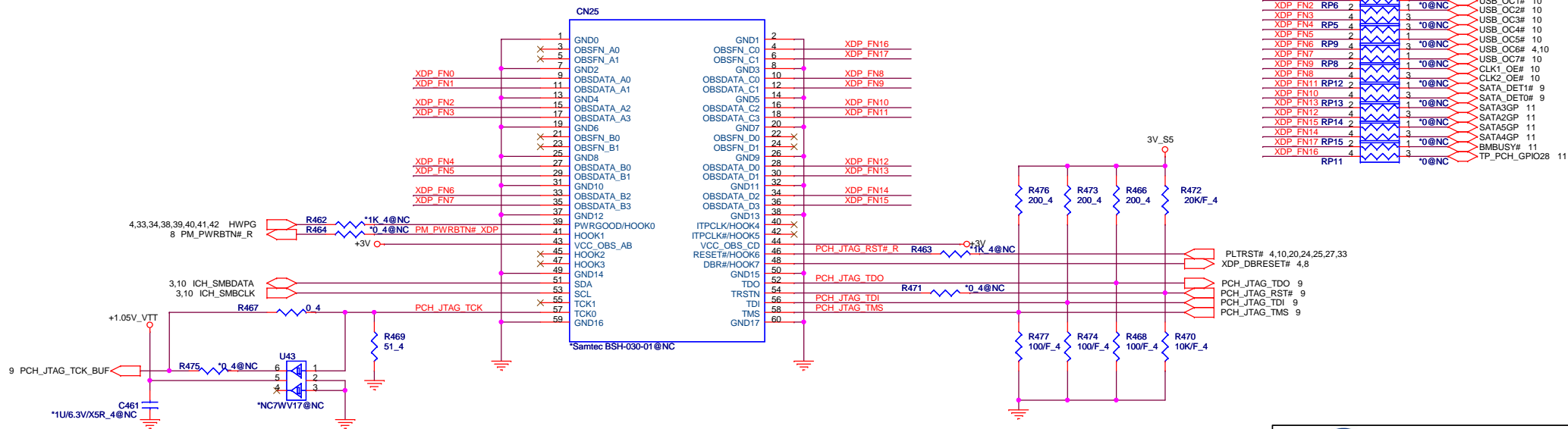
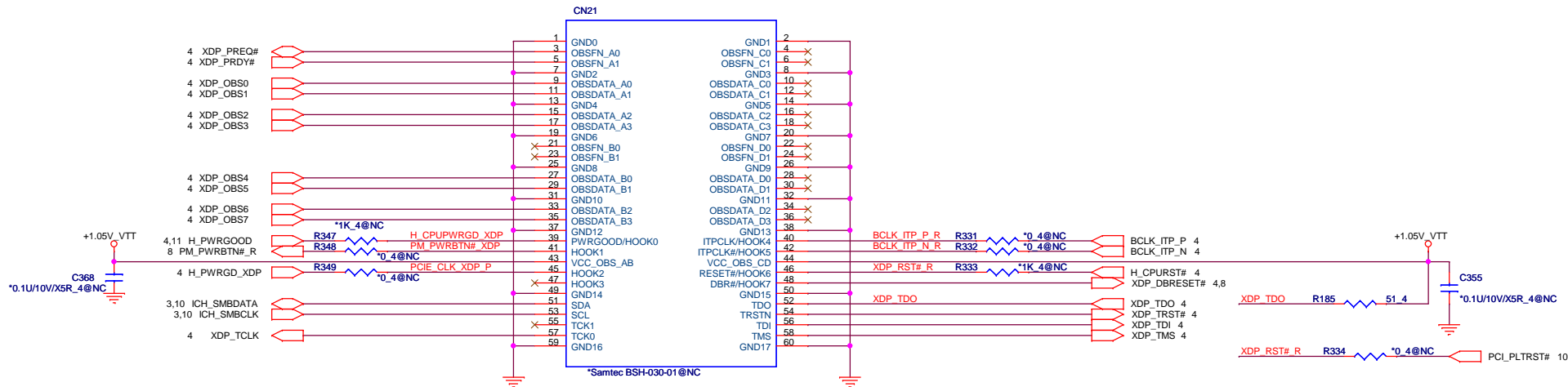

LD-Note Calpella UMA
Quanta Computer Inc.

Size	Document Number	Rev
Custom	XDP & PCH JTAG	
Date:	Saturday, November 07, 2009	Sheet 43 of 50

Revision	Date	Phase	Change List	Release Schematic Date	Release Gerber File Date
1A		DV	Initial release		

Schematic Value Explanation Description :

RESISTOR

Value	F	4	6	8	12	1210	*	Description
*1K/F_4	1%	0402 (1005)					DE POP	1K ohm 1% SMD 0402 package and DE POP
1K_6	5%		0603 (1608)				POP	1K ohm 5% SMD 0603 package and POP
1K_8	5%			0805 (2125)			POP	1K ohm 5% SMD 0805 package and POP
1K_12	5%				1206 (3216)		POP	1K ohm 5% SMD 1206 package and POP
1K_1210	5%					1210 (3225)	POP	1K ohm 5% SMD 1210 package and POP

CAPACITOR

Value	Voltage	Material	6				*	Description
*0.1U/10V/X5R_4	10V	X5R	0402 (1005)				DE POP	0.1UF 10V X5R SMD 0402 package DE POP
1U/25V/X7R_6	25V	X7R	0603 (1608)				POP	0.1UF 25V X7R SMD 0603 package POP

EC NO.	Page	Date	Part reference	Description
EC-C-1	23	10/30	CML3,CML4,R493/R494/R495/R496	POP CML1/CML3/CML4 for EMI Suggestion U12 Only use DBBL5MLAN01
	22		CML1,R38,R39	
	27		L26,R178,R179	
	20		U12	
EC-C-2	19	10/30	Q35,Q40,Q41	Q40 change to BA001440Z87 Q35 change to BAM70020058 Q41 change to BA039040ZA9
EC-C-3	10	10/30	U38	Modify Card Reader PORT
EC-C-4	35	10/30	HOLE11,HOLE3,HOLE21	Change footprint
EC-C-5	41	10/30	PR134,PR135,PC74,PC75	POP and PC74,PC75 change to 1000PF
EC-C-6	19	11/02	L17,C34,U15,C24,C39,C40	L17:DEPOP;C34,U15,C24,C39,C40:POP feedbacks from RealTek about audio issue
EC-C-7	22	11/02	U41	Modify Enable Pin connect to AOU_USB_ON# for AOU3 functon and delete cell select function
EC-C-8	18	11/02	CN17	Modify CRTVSYNC,CRTHSYNC,DDCCLK3,DDCDAT3
EC-C-9	30	11/02	Q24,Q28,Q20,C381,C382,C383, U36,C389,R356,R357,Q25,Q26,Q27	DEPOP
EC-C-10	38	11/02	PR206,PR279,PQ82	PR206:DEPOP PR279,PQ82:POP



LD-Note Calpella UMA
Quanta Computer Inc.

Size B	Document Number EC list 1	Rev
Date: Saturday, November 07, 2009	Sheet 46 of 50	

EC NO.	Page	Date	Part reference	Description
EC-C-11	37	11/02		From a field issue, Lenovo system needs to have battery sense function. MBATV shall be connected to ADC1/GPI1@KBC.
EC-C-12	33	11/02	U37	Change iTPM Power to 3V_S5
EC-C-13	22	11/02	U52	Change to MAX14550AEETB+
EC-C-14	8	11/02	R447	PCIE_WAKE# Pull high Resistor change to 10K
EC-C-15	30	11/03	R350	R350 change to 11.2K
EC-C-16	18	11/04	C347	Modify to CRT_VCC_R
EC-C-17	19	11/05	U11,R628,R629,C673,R630,R450	Chip Change version to ALC269Q-VA6 POP:R628,R630,R450 DEPOP:R629,C673
EC-C-18	33	11/05	U37	Change Part to 4M bytes Material
EC-C-19	08-13	11/06	U38	Change footprint
EC-C-20	10	11/06	R444	Add part

 LD-Note Calpella UMA Quanta Computer Inc.		Rev
		EC list 2
Size Custom	Document Number	Date: Saturday, November 07, 2009
		Sheet 47 of 50

EC NO.	Page	Date	Part reference	Description
EC-C-21		11/06	TP49、TP44、TP73、TP16、TP6、TP93 & TP98 TP112、TP99、TP32、TP47、TP34、TP101、TP103	Change footprint to TP3050

		LD-Note Calpella UMA Quanta Computer Inc.	
Size Custom	Document Number EC list 2	Rev	
Date: Saturday, November 07, 2009	Sheet 48	of 50	1

USB Port	Device	PM55 Support	HM55 Support	DV-Stage(UMA)	DV-Stage(Discrete)
Port0	USB Port	V	V	HM55	HM55
Port1	USB Port	V	V	HM55	HM55
Port2	New Card	V	V	HM55	HM55
Port3	Camera	V	V	HM55	HM55
Port4	WLAN	V	V	HM55	HM55
Port5	WWAN	V	V	HM55	HM55
Port6	Card Reader	V	X	HM55	HM55
Port7	NC	V	X	HM55	HM55
Port8	USB Port	V	V	HM55	HM55
Port9	USB Port	V	V	HM55	HM55
Port10	Fingerprint	V	V	HM55	HM55
Port11	NC	V	V	HM55	HM55
Port12	NC	V	V	HM55	HM55
Port13	Bluetooth	V	V	HM55	HM55