

TABLE OF CONTENTS

PAGE	PAGE	PAGE
1. COVER PAGE	26. CARDREADER	51. PCH 5 USB
2. INDEX	27. MINI1 WLAN/DEBUG CARD	52. PCH 6 MISC
3. BLOCK DIAGRAM	28. MINI2 3G/LTE	53. PCH 7 POWER
4. POWER MAP	29. SATA HDD/ODD CONN	54. PCH 8 POWER
5. POWER CHARGER	30. USB 2.0 CONN	55. PCH 9 GND
6. POWER +V3LA/+V3A/+5A	31. USB 3.0 CONTROLLER(REMOVE)	56. VGA 1
7. POWER +V1.5/+V0.75	32. USB 3.0 CONN W/ S&C	57. VGA 2
8. POWER +V1.8S	33. USB 3.0 CONN	58. VGA 3
9. POWER VCCIO	34. LCM CONN	59. VGA 4
10. POWER VCCSA	35. CRT CONN	60. VGA 5
11. POWER VCORE	36. HDMI CONN	61. VGA 6
12. POWER VGFX	37. HDMI CEC	62. VRAM 1
13. POWER VCORE_DGPU	38. DDR3 DIMM0	63. VRAM 2
14. ENABLE PIN	39. DDR3 DIMM1	64. VRAM 3
15. LOAD SWITCH-1	40. FAN & THERMAL SENSOR	65. VRAM 4
16. LOAD SWITCH-2	41. CPU 1	66. USB BOARD
17. PCB SCREW	42. CPU 2	67. PICK BUTTON BOARD(4 PIN)
18. HALL SENSOR	43. CPU 3 DRAM	68. POWER BUTTON BOARD
19. LED	44. CPU 4 POWER	69. EMI
20. K/B & TP/B CONN	45. CPU 5 POWER	70. PICK BUTTON BOARD(8 PIN)
21. EC	46. CPU 6 GND	
22. LAN	47. PCH 1	
23. RJ45 & TRANSFORMER	48. PCH 2	
24. AUDIO CODEC	49. PCH 3	
25. SPEAKER/HP JACK/MIC JACK	50. PCH 4 AXG	

INVENTEC

TITLE			
MODEL,PROJECT,FUNCTION Block Diagram			
SIZE A3	CODE CS	DOC NUMBER 1310xxxx-0-0	REV X01

CHANGE by XXX

DATE 21-OCT-2002

SHEET 2 of 70

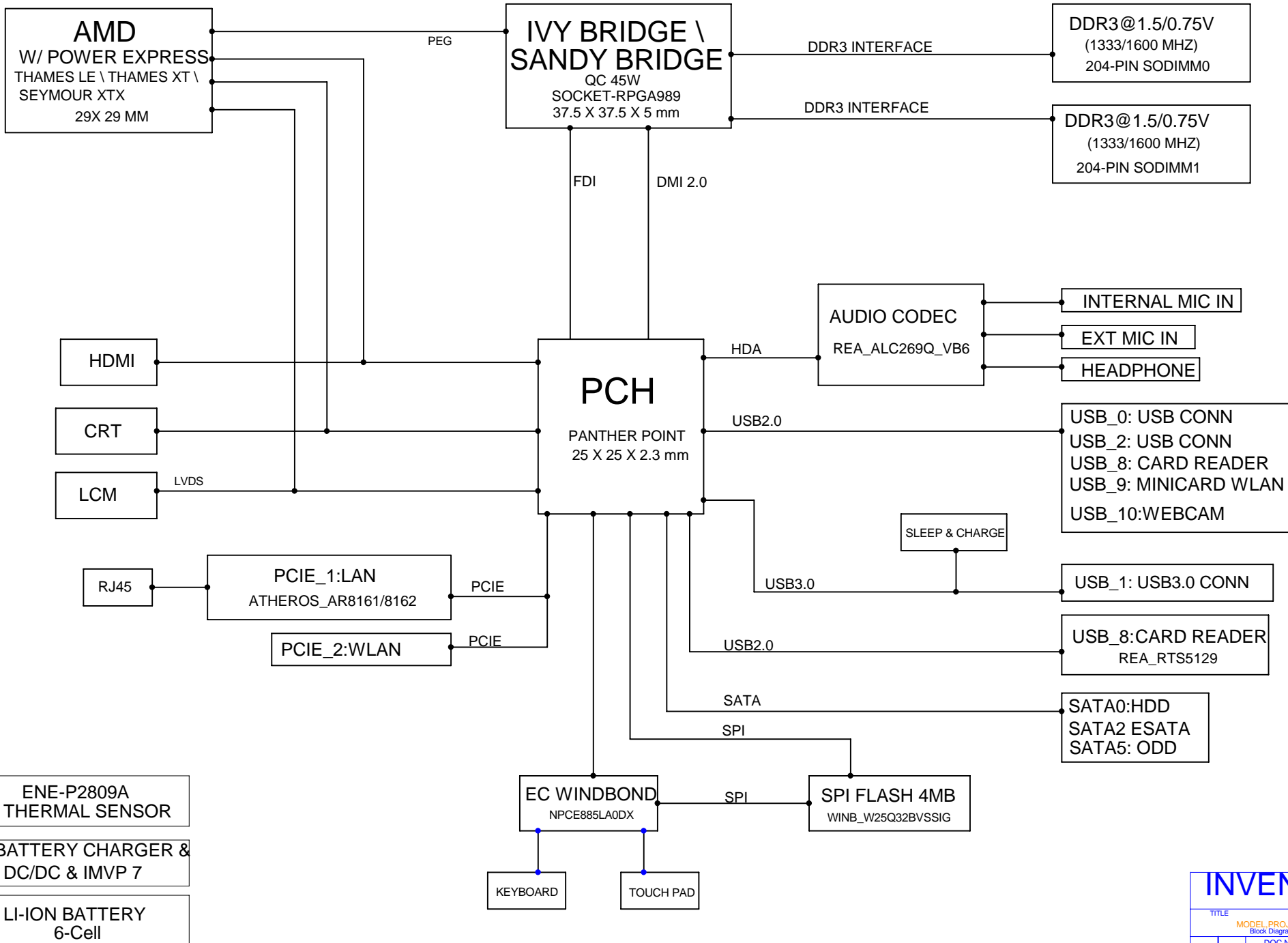

ENE-P2809A
THERMAL SENSOR

BATTERY CHARGER &
DC/DC & IMVP 7

LI-ION BATTERY
6-Cell

INVENTEC			
TITLE			
Block Diagram			
MODEL, PROJECT, FUNCTION			
SIZE	CODE	DOC NUMBER	REV
A3	CS	1310xxxx-0-0	X01
CHANGE by XXX			
DATE 21-OCT-2002			
SHEET 3 of 70			

ADAPTOR

65W-75W 8A 6036A0003401
90W 10A 6036A0002901
120W 12A 6036A0006001

FUSE

BQ24725RGRR
CHARGER

EC_SMB2;
CHG_EN
BATT_IN
ACPRES

BATTERY PACK

+VBAT

TPS51123

POWER BUDGET 14.745 A
F 300K
OCP 10.52A R=140K
PEAK 9.23A AVG 1.809A
330UF_25MΩ // 49.1UF_6.648MΩ

+V5A_+5%

NMOS

POWER BUDGET 4.711A INRUSH 0.55A
PEAK2.592A 122.42UF_0.658MΩ

+V5S

TSP51461

POWER BUDGET 6A
F 340K
OCP 6A
PEAK 6A AVG 1.262A

+V0.85S_+0.5%

+VCORE_+0.5%

+VCORE_+0.5%

TPS51650

POWER BUDGET 94A
F 280K
OCP 104.5A
PEAK 94A AVG 45.3A
1880UF_1.1MΩ // 2276UF_0.203MΩ

+V3LA_+5%

TPS51123

POWER BUDGET 12.186 A
F 375K
OCP 8.40A R=120K
PEAK 7.31A AVG1.7 A
3300UF_25MΩ // 6.7UF_5.458MΩ

+V3A

NMOS

POWER BUDGET 4.711A INRUSH 0.984A
PEAK2.592A 8.6UF_8.409MΩ

NMOS

POWER BUDGET 4.711A INRUSH 0.464A
PEAK2.592A 5.9UF_9.497MΩ

+V3_LAN

NMOS

POWER BUDGET 4.711A INRUSH 1.06A
PEAK2.592A 75.6UF_0.986MΩ

RT8068

POWER BUDGET 4.711A INRUSH 0.6A
PEAK2.592A 56.12UF_1.505MΩ

+V1.8S

VDD_CORE

TPS51728

POWER BUDGET 46A
F 340K
OCP 50A
PEAK 46A AVG 38.7A
560UF_25MΩ // 80UF_0.93MΩ

+V3A

NMOS

POWER BUDGET 4.711A INRUSH 0.496A
PEAK2.592A 13UF_5.803MΩ

+V3S_DGPU

+V1.5_+5%

TPS51216

POWER BUDGET 33.033 A
F 340K
OCP 20.1A R=56.2K
PEAK 19.82A AVG8.802 A
330UF_15MΩ // 480UF_0.560MΩ

TPS51216

NMOS

NMOS

NMOS

+V0.75S

+V1.5S_DGPU

+V1.5S

+V1.5_CPU

+V1.05_+5%

TPS51219

POWER BUDGET 19.218 A
F 340K
OCP 13.2A R=115K
PEAK 11.53A AVG 6.704A
560UF_25MΩ // 359.9UF_0.213MΩ

CHANGING POINTS--
TPS51211 IS NEW IC
+V1.8S IS NEW IC RT8068
VDD CORE IS NEW IC TPS51728
CHARGE IS NEW IC BQ24725
VCC CORE IS NEW IC TPS51650
VTT IS NEW IC TPS51219
V0.85 IS NEW IC TPS 51641
V3_V5 IS NEW IC TPS51123
POWER BUDGET --IC SPEC (MAX CURRENT)
PEAK CURRENT --RATIO OF INTERNAL PREDICTION
AVG CURRENT --TEST RESULT(MAX CURRENT)
INRUSH --L/S TURN NO

INVENTEC			
TITLE			
MODEL PROJECT.FUNCTION			
Block Diagram			
SIZE A3	CODE CS	DOC NUMBER 1310xxxx-0-0	REV X01
CHANGE by XXX		DATE 21-OCT-2002	SHEET 4 of 70

FUSE6000
65W-75W 8A(6036A0003401)
90W 10A(6036A0002901)
120W 12A(6036A0006001)

D

C

B

A

D

C

B

A

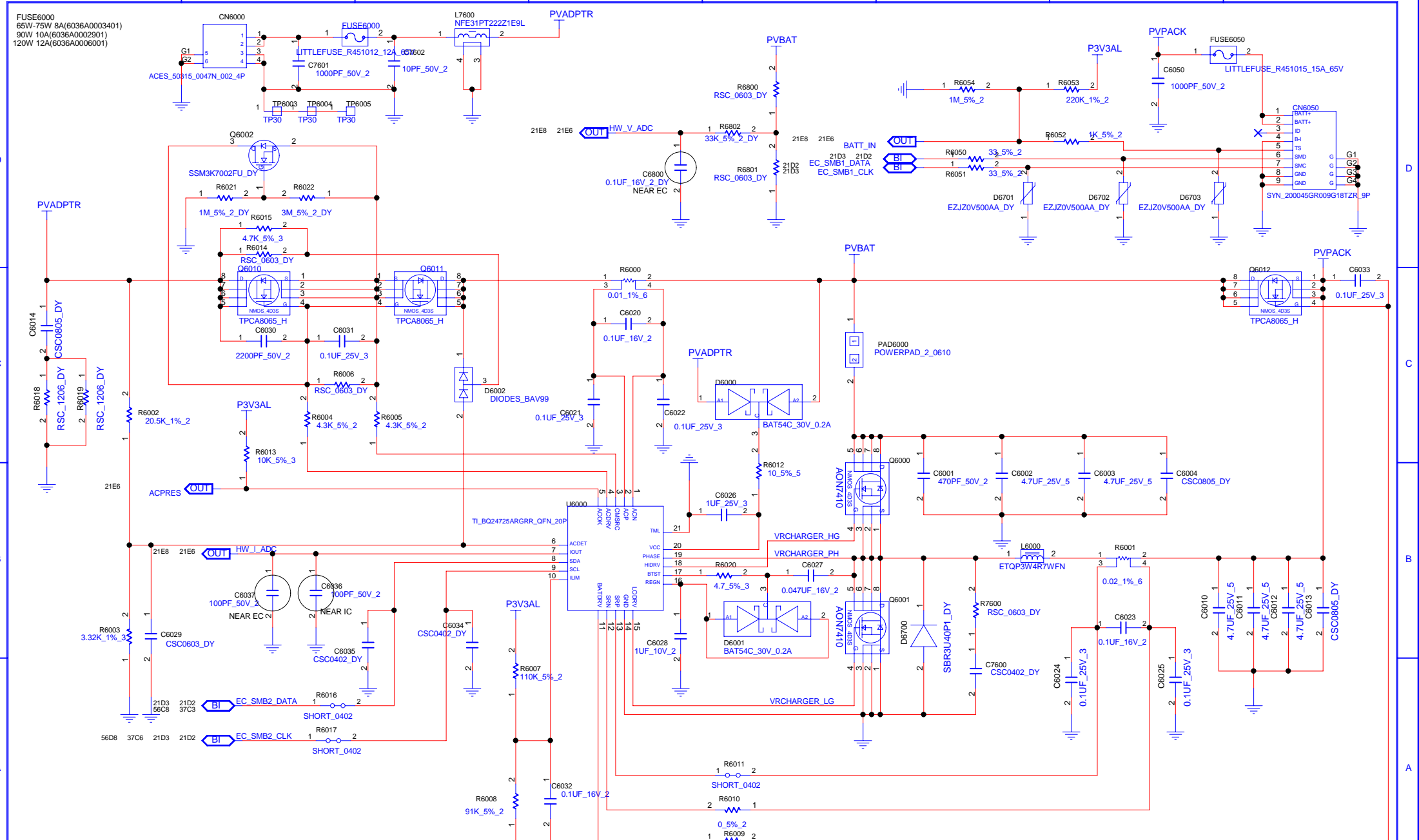

INVENTEC			
TITLE			
MODEL PROJECT FUNCTION			
Block Diagram			
SIZE		REV	
A3	CODE	CS	X01
DOC NUMBER			
1310xxxxx-0-0			
DATE			
21-OCT-2002			
SHEET			
5 of 70			

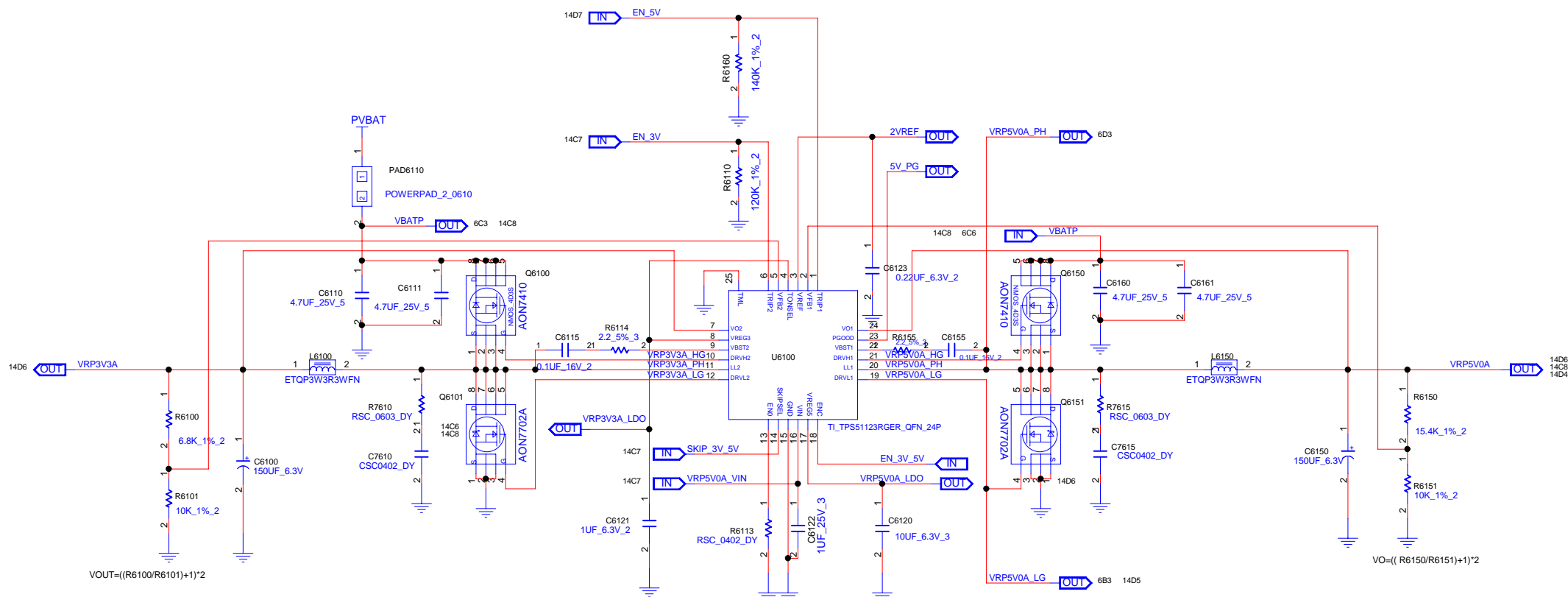

INVENTEC			
TITLE			
MODEL PROJECT FUNCTION			
Block Diagram			
SIZE	CODE	DOC NUMBER	REV
A3	CS	1310xxxx-0-0	X01
CHANGE by XXX		DATE 21-OCT-2002	SHEET 6 of 70

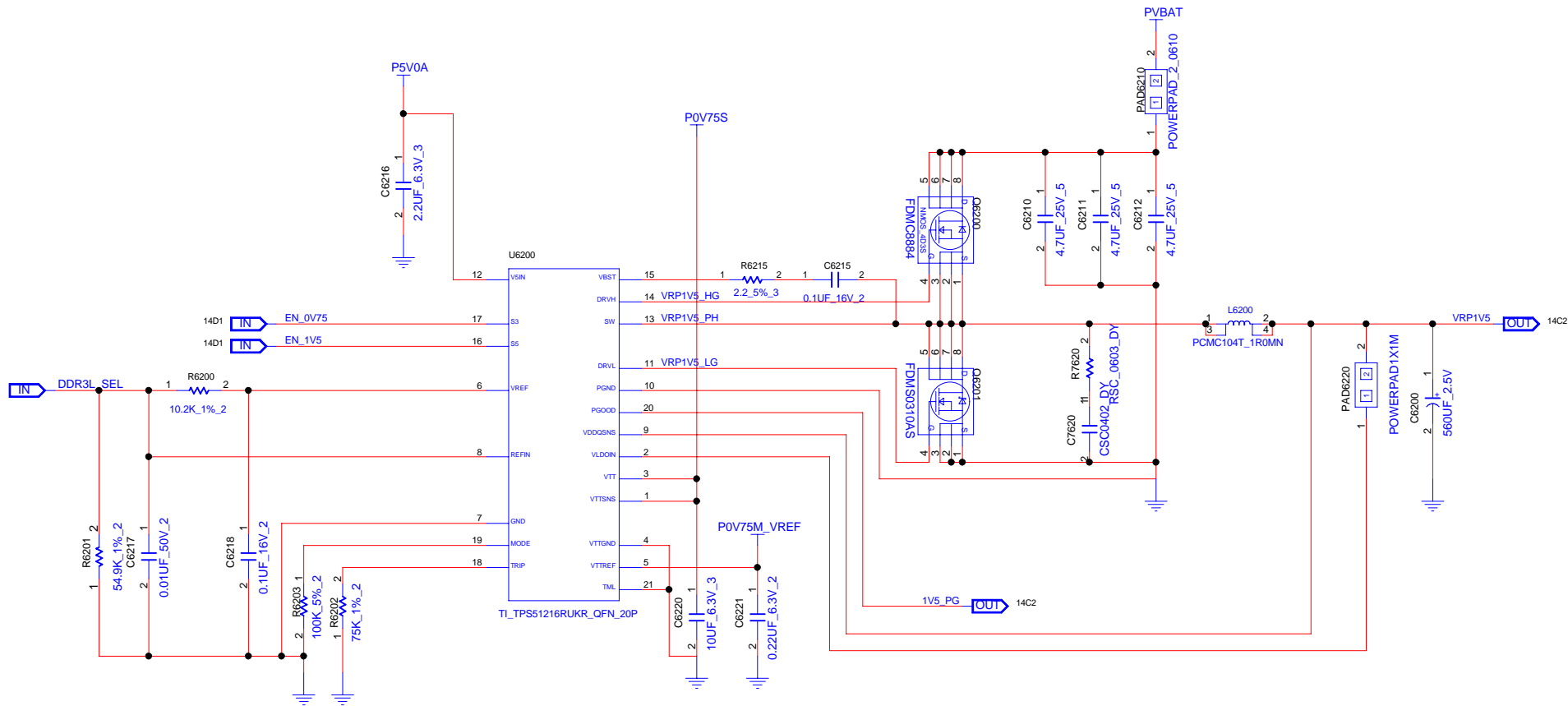

$V_{OUT} = V_{REF} = 1.8 \cdot (R_{6201} / (R_{6201} + R_{6202}))$
 MODE=100KOHM:TRACKING DISCHARGE

STATE	S3	S5	VREF	VDDQ	VTTREF	VTT
S0	HI	HI	ON	ON	ON	ON
S3	LO	HI	ON	ON	ON	OFF(High-Z)
S4/S5	LO	LO	OFF	OFF(Discharge)	OFF(Discharge)	OFF(Discharge)

INVENTEC

TITLE
 MODEL PROJECT FUNCTION
 Block Diagram
 SIZE A3 CODE CS DOC NUMBER 1310xxxx-0-0 REV X01

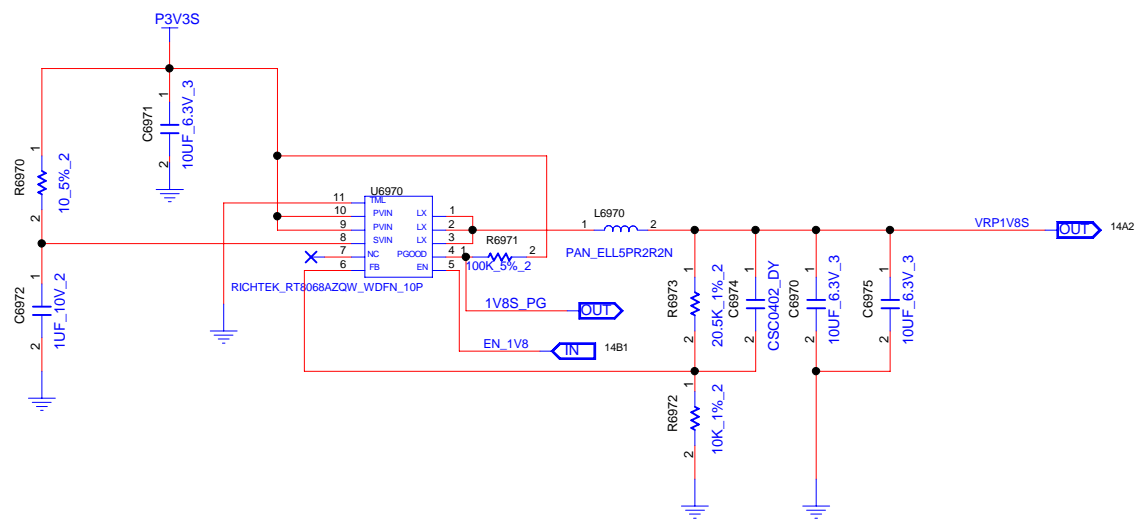

INVENTEC			
TITLE			
MODEL,PROJECT,FUNCTION Block Diagram			
SIZE A3	CODE CS	DOC NUMBER 1310xxxxx-0-0	REV X01

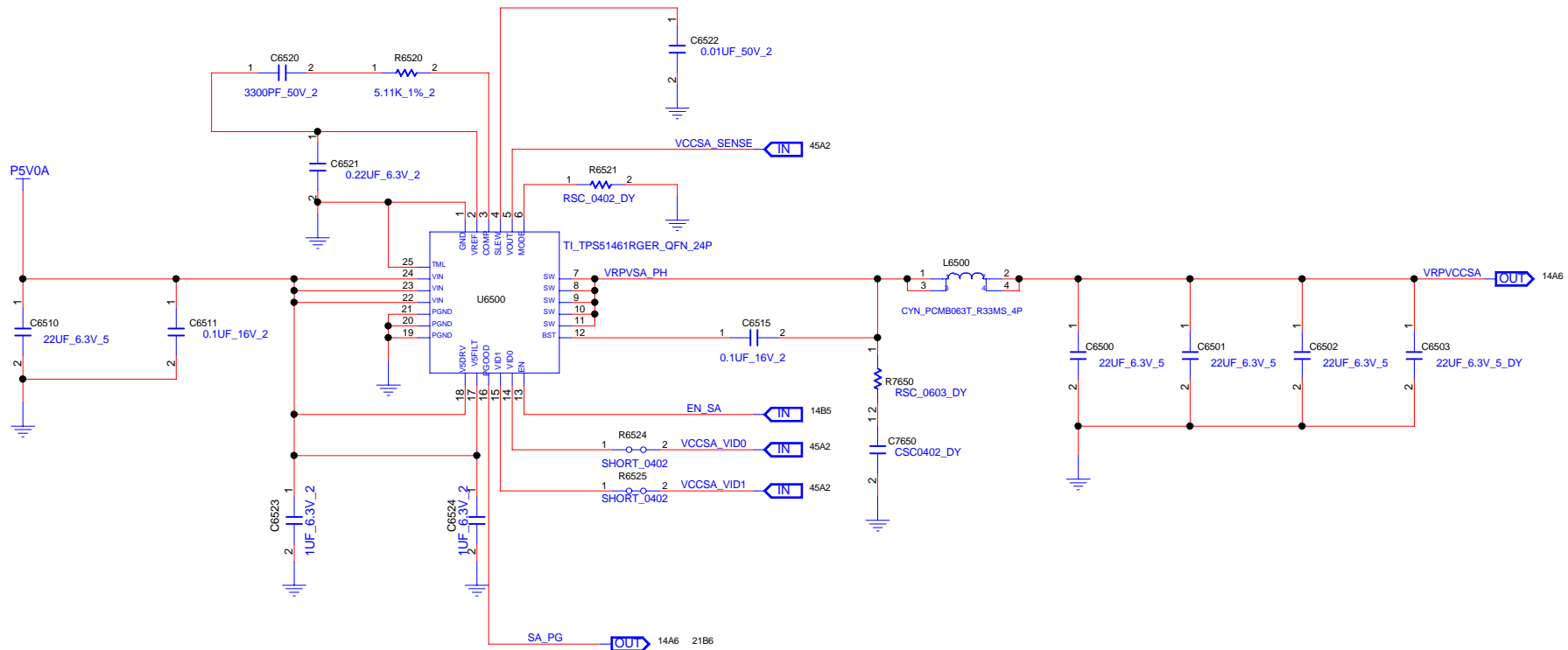

INVENTEC

TITLE			
MODEL, PROJECT, FUNCTION			
Block Diagram			
SIZE	CODE	DOC NUMBER	REV
A3	CS	1310xxxx-0-0	X01

UMA/PX DIS.		3+2	3+0	2+1	2+0
R6620	71.5K	71.5K	44.2K	44.2K	
R6621	42.2K	42.2K	90.9K	90.9K	
R6622	100K	100K	39K	39K	
R6626	4.7K	DNP	3.3K	DNP	
R6627	75K	DNP	56K	DNP	
R6711	100K	DNP	200K	DNP	
R6712	24K	DNP	30K	DNP	
R6719	DNP	0	DNP	0	
R6723	DNP	0	DNP	0	
R6635	DNP	DNP	0	0	
R6636	DNP	DNP	0	0	
R6714	DNP	0	DNP	0	
R6716	DNP	0	DNP	0	
R6721	DNP	0	0	0	
R6725	DNP	0	0	0	
R6726	0	DNP	DNP	DNP	
R6724	0	DNP	DNP	DNP	
R6722	0	DNP	DNP	DNP	
R6720	0	DNP	0	DNP	
R6713	0	DNP	0	DNP	
R6715	0	DNP	0	DNP	

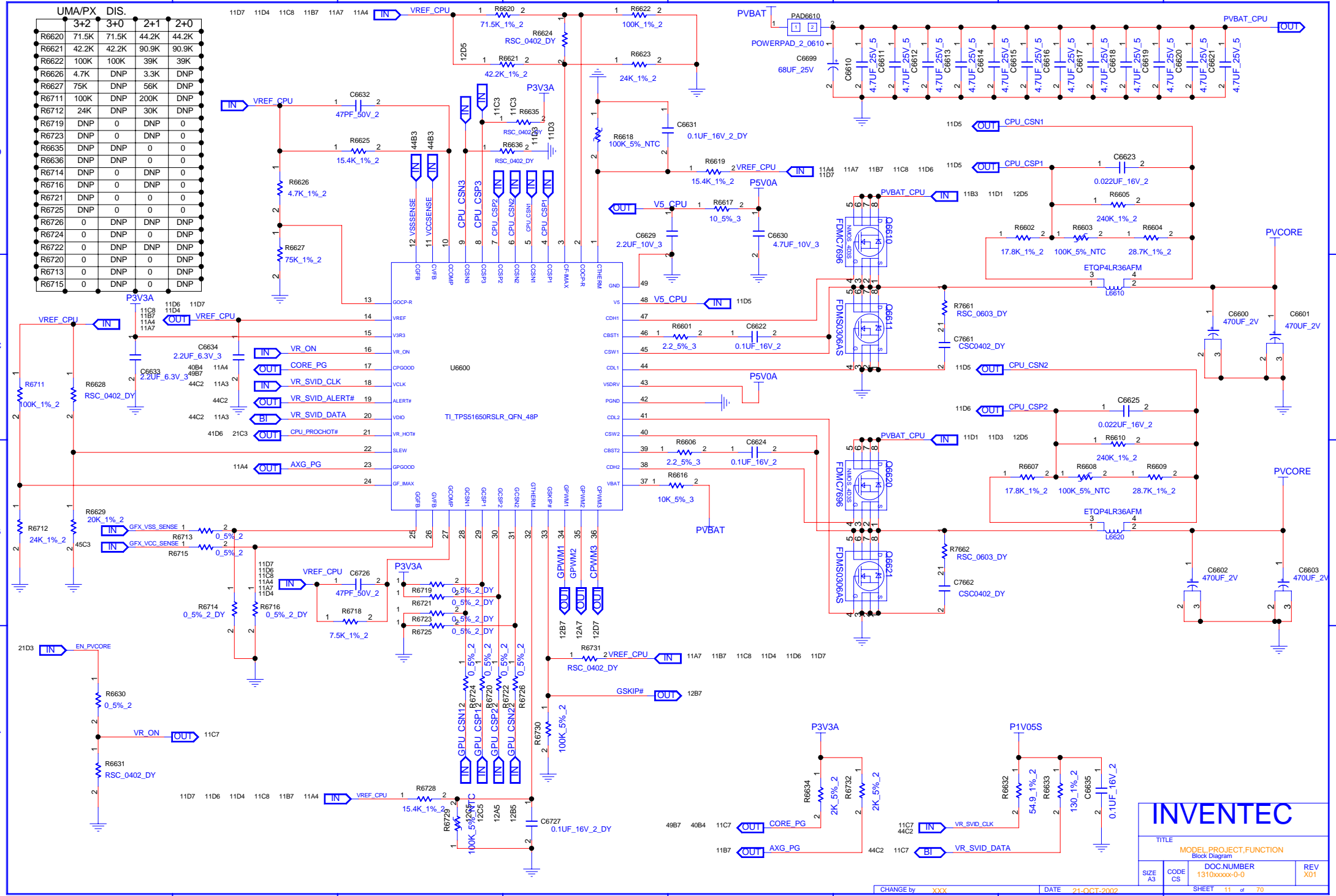

INVENTEC

TITLE			
MODEL PROJECT FUNCTION			
Block Diagram			
SIZE	CODE	DOC NUMBER	REV
A3	CS	1310xxxx-0-0	X01

CHANGE by XXX DATE 21-OCT-2002 SHEET 11 of 70

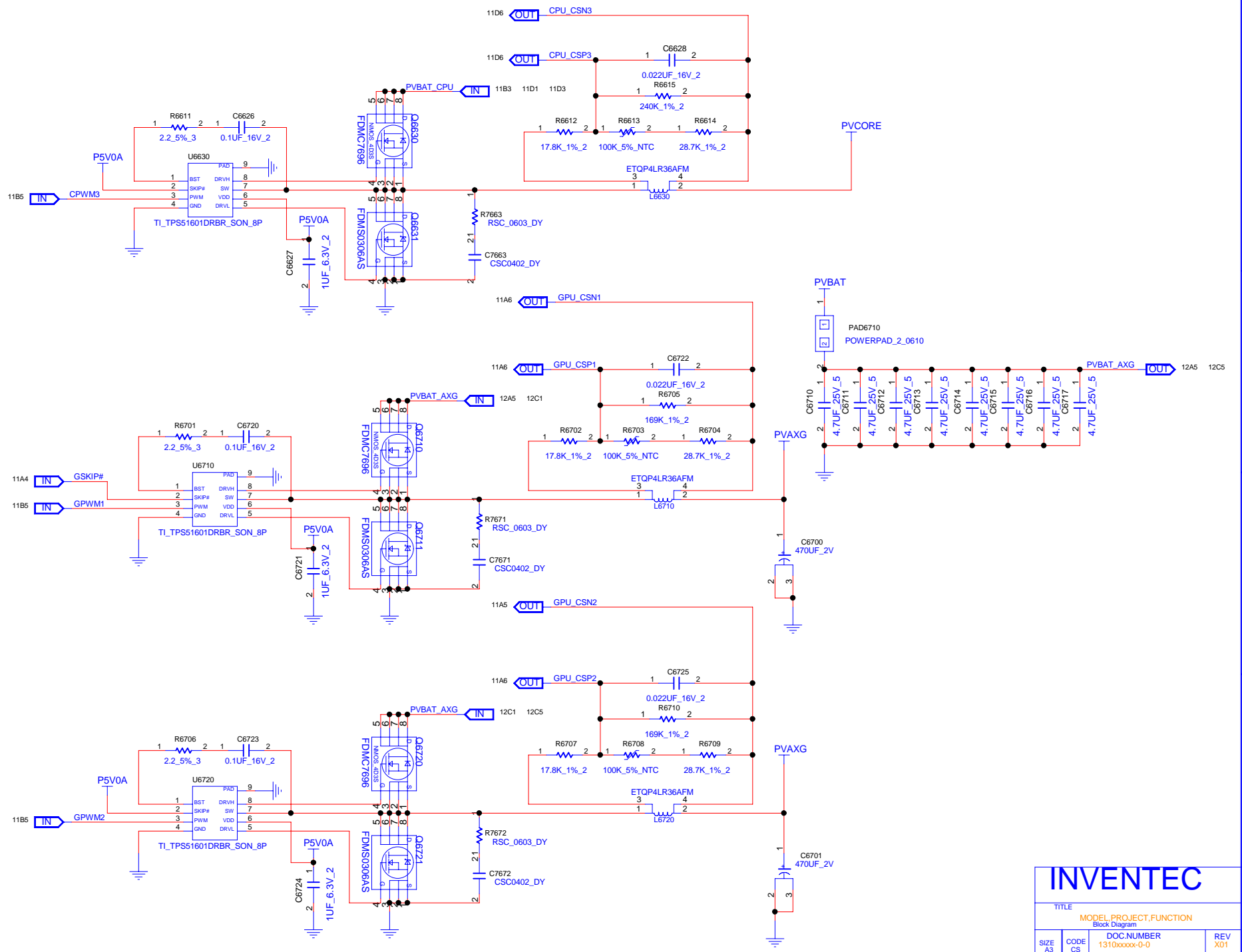

INVENTEC			
TITLE			
MODEL PROJECT FUNCTION			
Block Diagram			
SIZE	CODE	DOC NUMBER	REV
A3	CS	1310xxxx-0-0	X01
CHANGE by		DATE	SHEET
XXX		21-OCT-2002	12 of 70

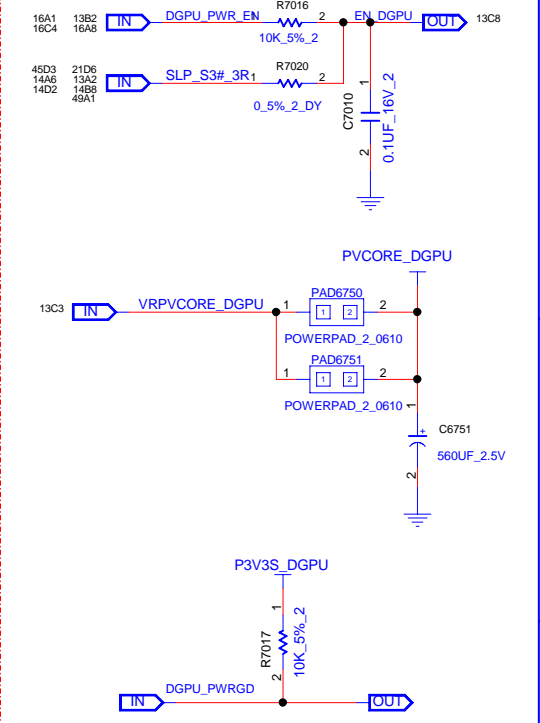
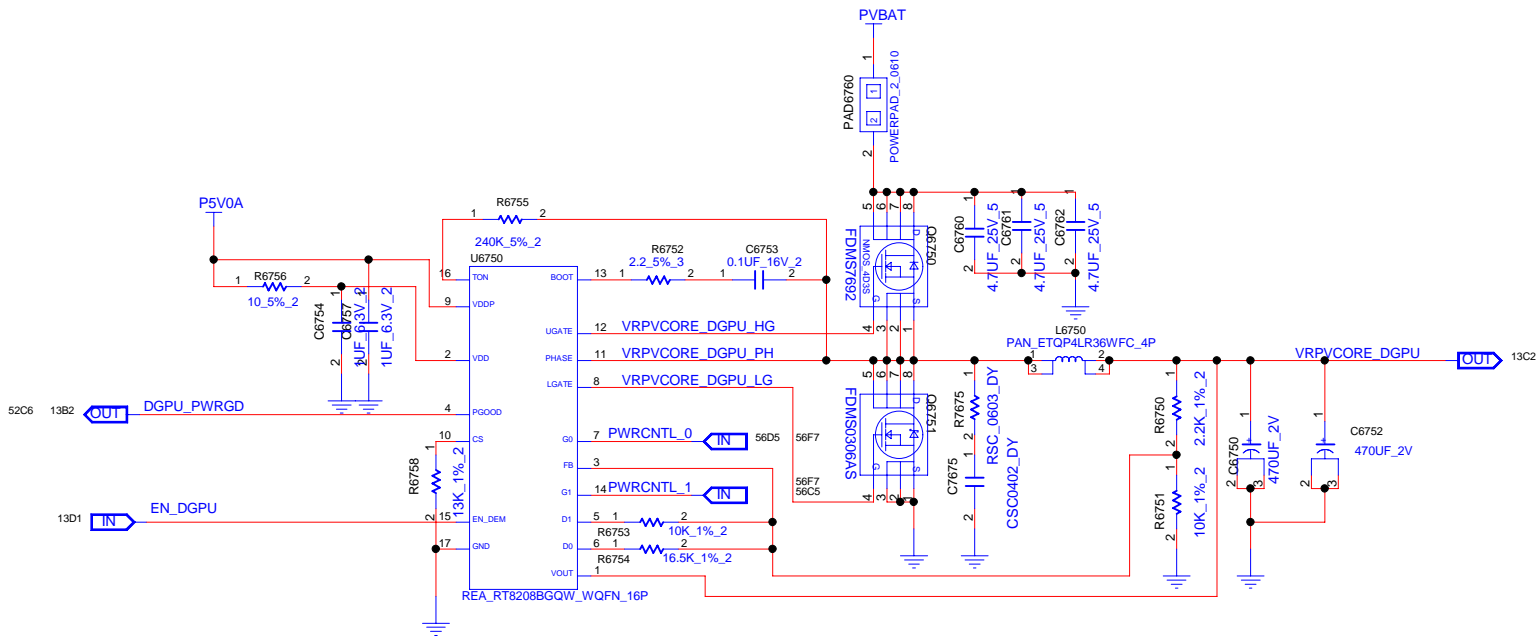

P.S. R6750(R1)R6751(R2)R6753(R3)R6754(R4)

VGA TYPE :	SEYMOUR XTX	THAMES XT	THAMES LE	RESISTOR VALUE	
G0	G1	VOUT	VOUT	VOUT	RESISTOR VALUE
0	0	1.15	N/A	N/A	R6750(R1) 2.2 K
0	1	1.05	N/A	N/A	R6751(R2) 10 K
1	0	1	1	1	R6754(R3) 16.5 K
1	1	0.9	0.9	0.9	R6753(R4) 10 K

RT8208A	RT8208B	Output Voltage Equation		
G0	G1	G0	G1	
0	0	1	1	$V_{OUT} = \frac{R1+R2}{R2} \times 0.75$
1	0	0	1	$V_{OUT} = \frac{R1+(R2/R3)}{(R2/R3)} \times 0.75$
0	1	1	0	$V_{OUT} = \frac{R1+(R2/R4)}{(R2/R4)} \times 0.75$
1	1	0	0	$V_{OUT} = \frac{R1+(R2/R3/R4)}{(R2/R3/R4)} \times 0.75$

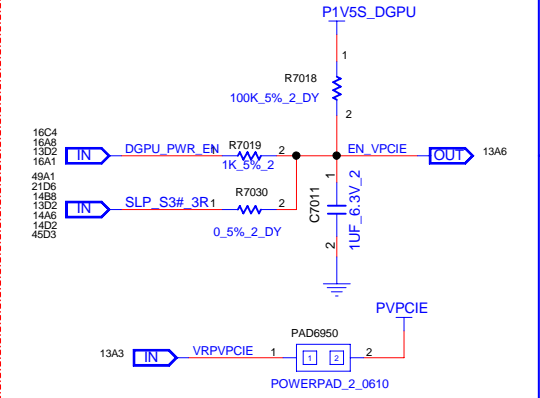
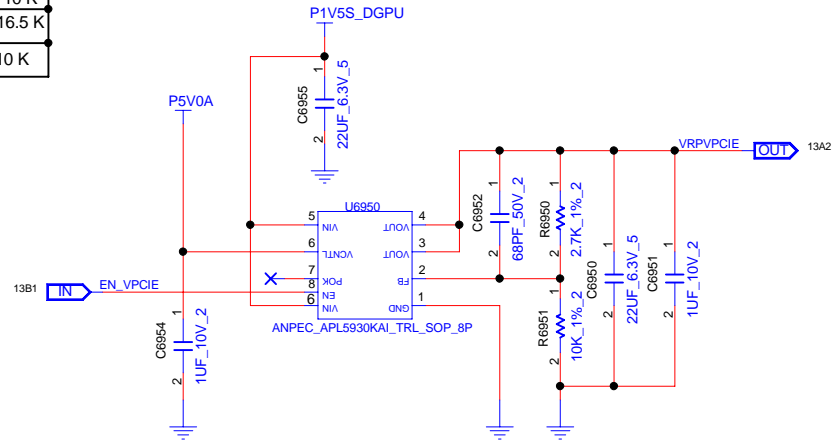

INVENTEC

TITLE: MODEL PROJECT FUNCTION
Block Diagram

SIZE A3	CODE CS	DOC NUMBER 1310xxxx-0-0	REV X01
---------	---------	-------------------------	---------

CHANGE by XXX DATE 21-OCT-2002 SHEET 13 of 70

3V & 5V

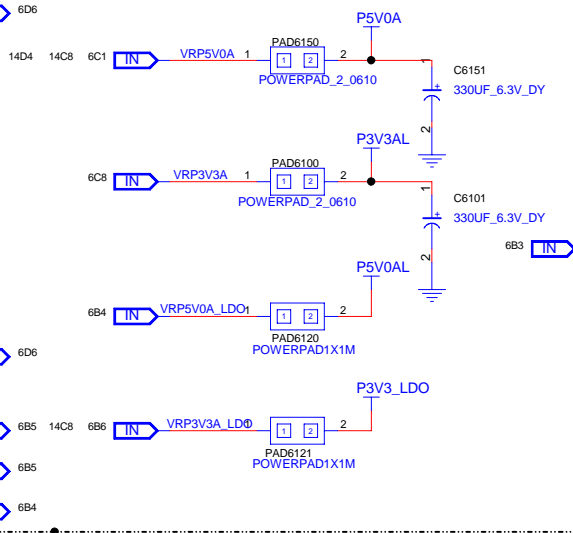
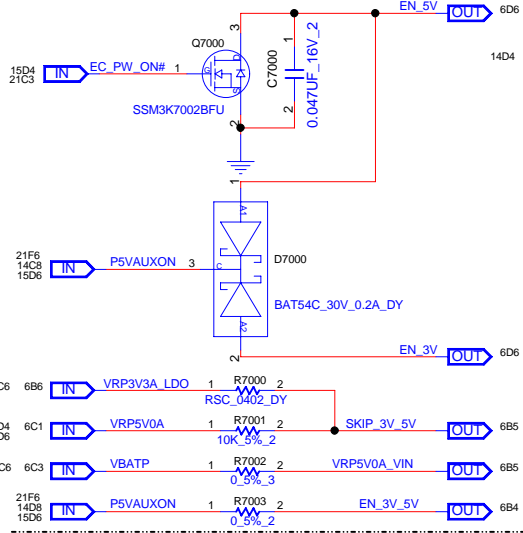

DDR_P1V5

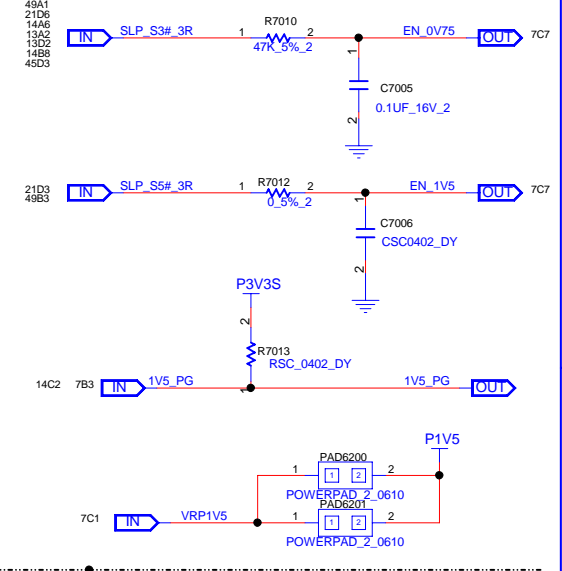

VCCIO

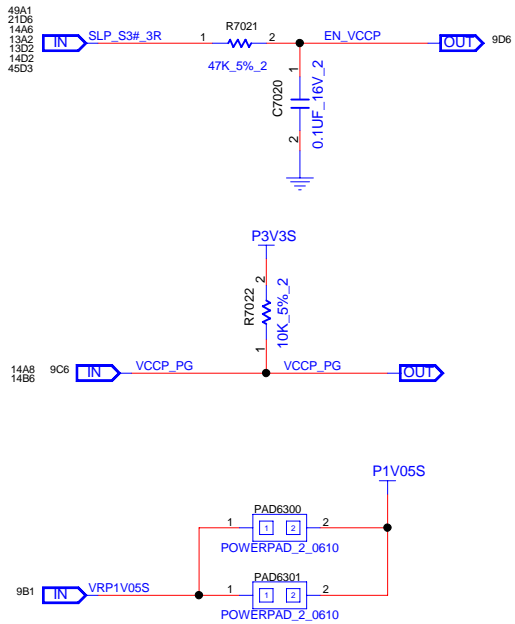

VCCSA

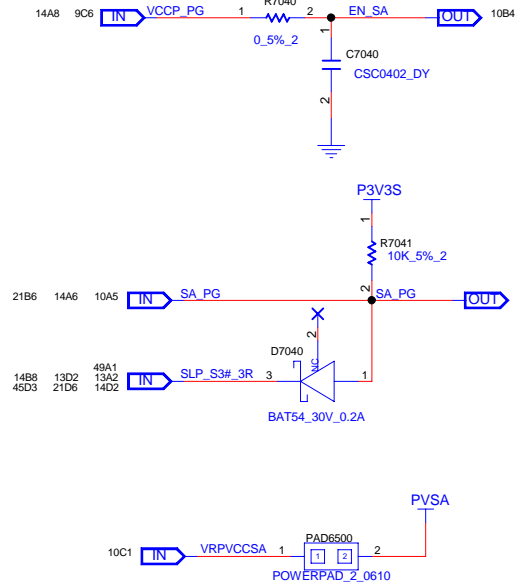

DGPU

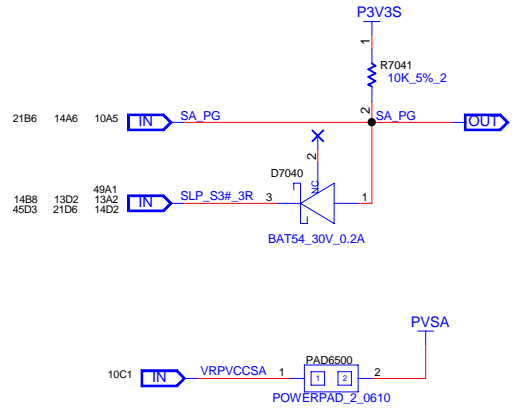

P1V8S

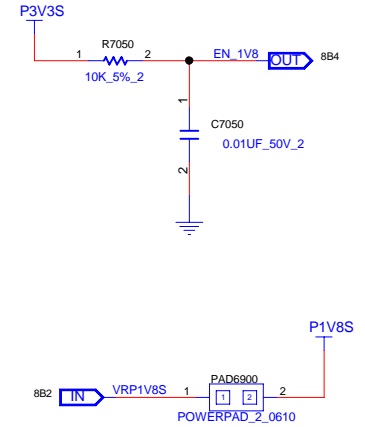

INVENTEC

TITLE			
MODEL PROJECT FUNCTION			
Block Diagram			
SIZE	CODE	DOC NUMBER	REV
A3	CS	1310xxxxx-0-0	X01

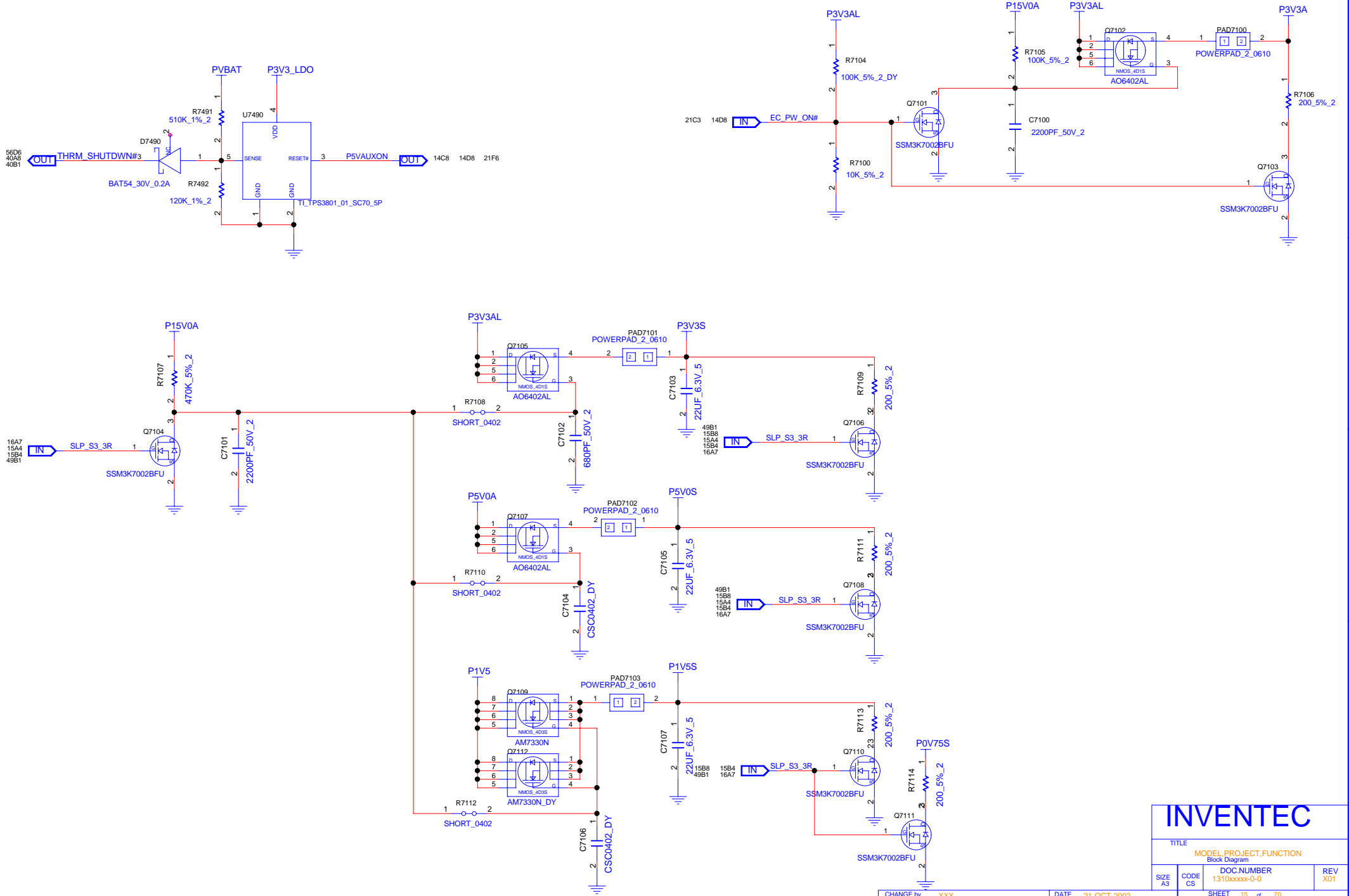

INVENTEC			
TITLE			
MODEL PROJECT FUNCTION			
Block Diagram			
SIZE	CODE	DOC NUMBER	REV
A3	CS	1310xxxx-0-0	X01
CHANGE by XXX		DATE 21-OCT-2002	SHEET 15 of 70

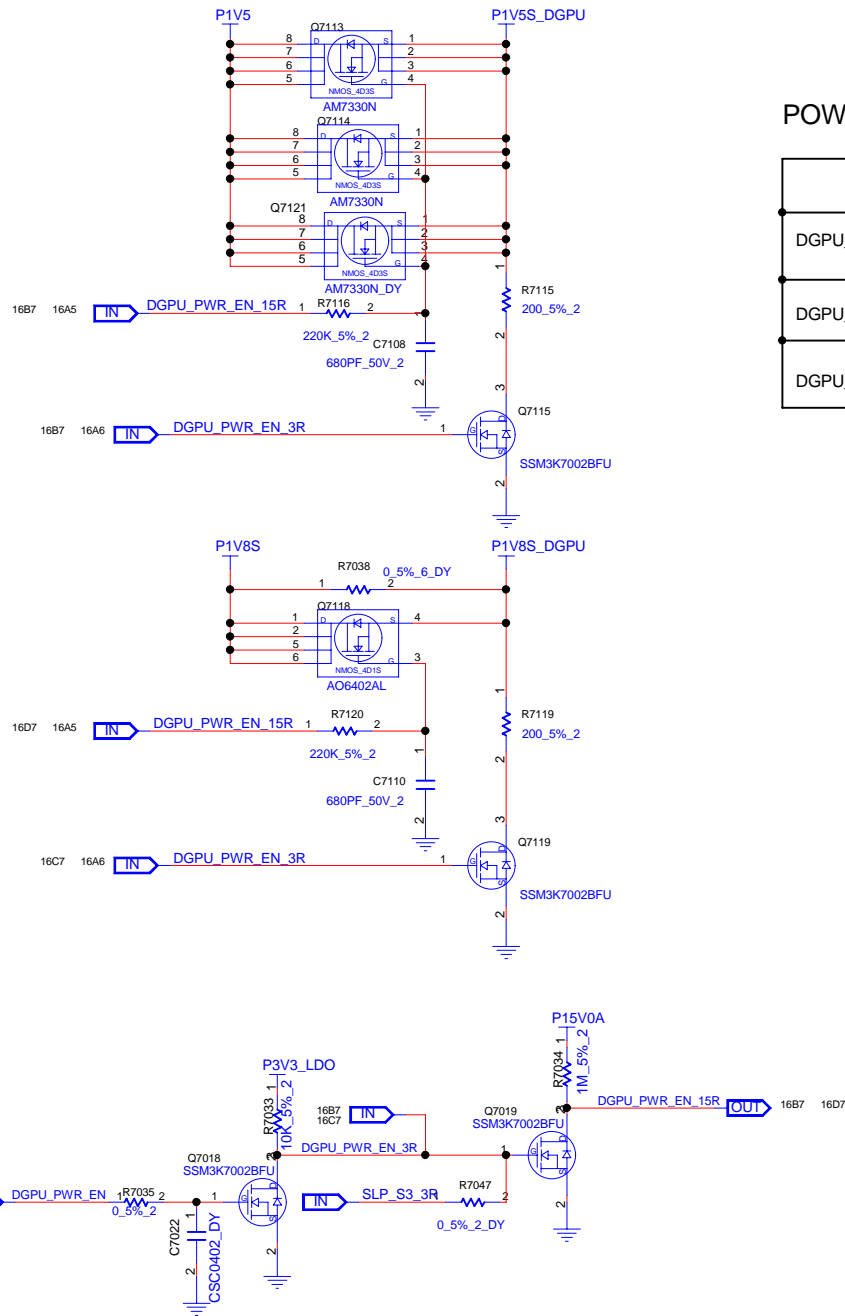

POWER EXPRESS

	DURING RESET	AFTER RESET	
DGPU_PWR_EN#	HIGH	HIGH	0 : DGPU POWER SWITCH TURNED ON 1 : POWER SWITCH TURNED OFF
DGPU_PWRGD			0 : DGPU POWER IS NOT STABLE 1 : DGPU POWER IS STABLE
DGPU_HOLD_RST#	LOW	LOW	0 : KEEP DGPU IN RESET 1 : RESET IS RELEASED

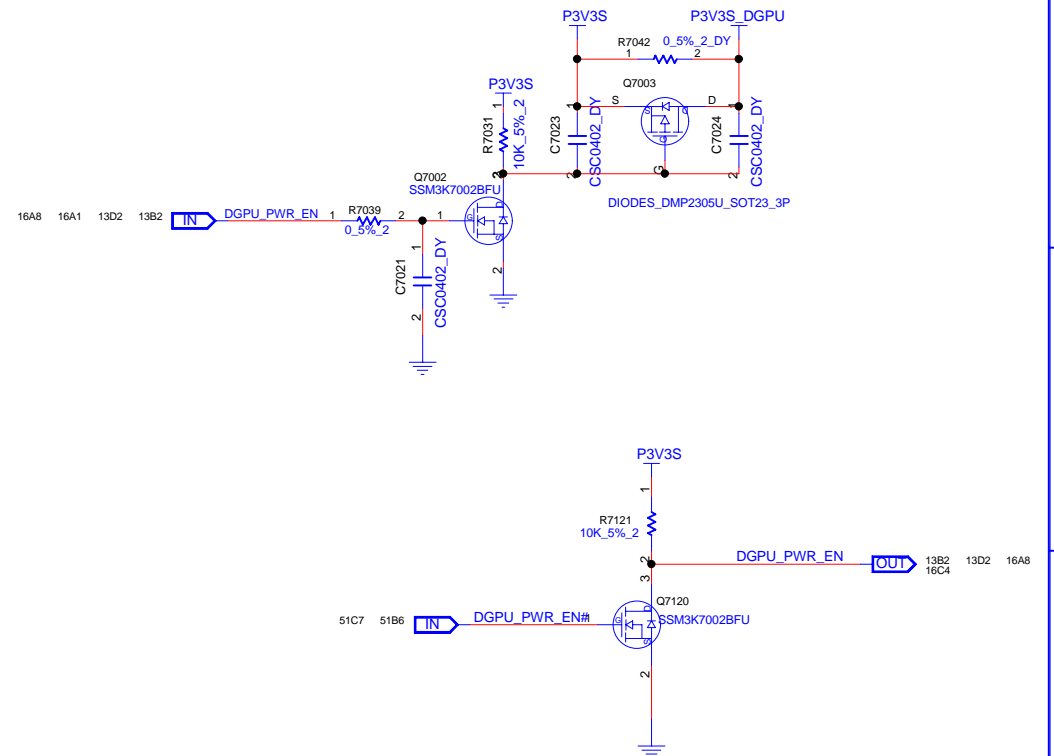

INVENTEC

TITLE			
MODEL, PROJECT, FUNCTION			
Block Diagram			
SIZE	CODE	DOC NUMBER	REV
A3	CS	1310xxxxx-0-0	X01

REFERENCE 0~49(PCB SCREW)

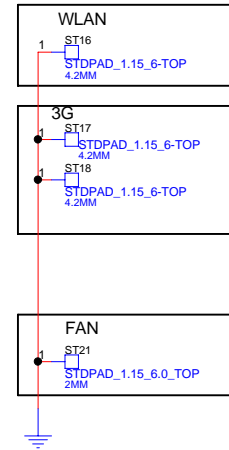
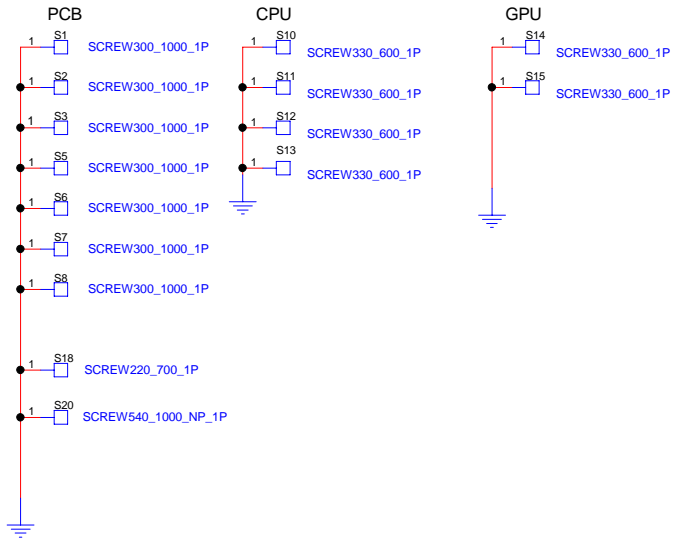
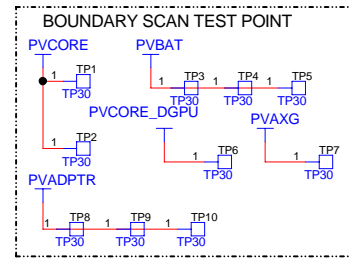
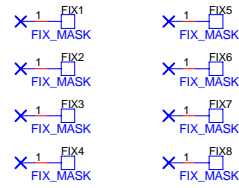

INVENTEC			
TITLE			
MODEL PROJECT FUNCTION Block Diagram			
SIZE A3	CODE CS	DOC NUMBER 1310xxxxx-0-0	REV X01

REFERENCE 50-99(HALL SENSOR)

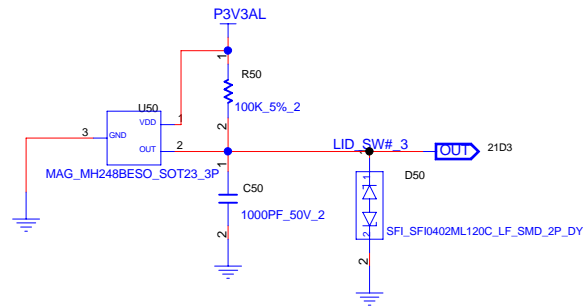

INVENTEC

TITLE			
MODEL PROJECT.FUNCTION			
Block Diagram			
SIZE	CODE	DOC NUMBER	REV
A3	CS	1310xxxx-0-0	X01

POWER ON LED

D154 BRIGHT WHEN SYSTEM IS POWER ON
 D154 BLINK WHEN SYSTEM GO TO SLEEP

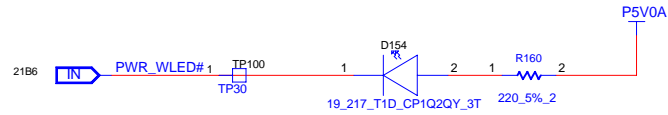

WIFI/WIMAX/3G/LTE LED

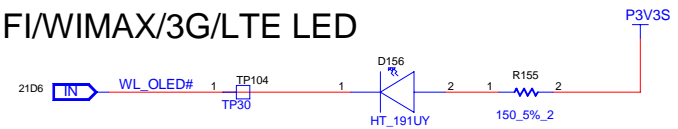

DC IN / BATTERY CHARGE LED

D152 BRIGHT: BOTH AC-ADAPTER IS PLUGGED IN AND BATTERY IS FULL CHARGED
 D155 BRIGHT: WHILE CHARGING BATTERY FROM AC-ADAPTER
 BLINK: LOW BATTERY

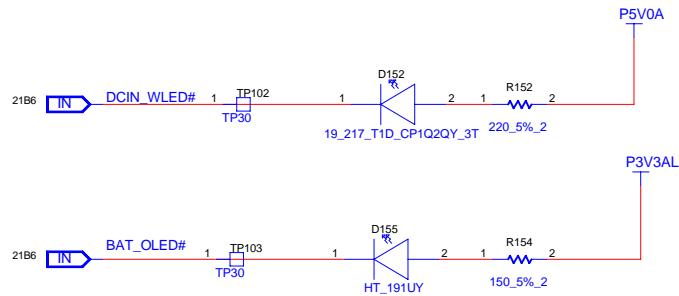

INVENTEC

TITLE			
MODEL PROJECT.FUNCTION			
Block Diagram			
SIZE	CODE	DOC NUMBER	REV
A3	CS	1310xxxx-0-0	X01

REFERENCE 200~249(POWER CONN)
 REFERENCE 250~299(KB/TP CONN)

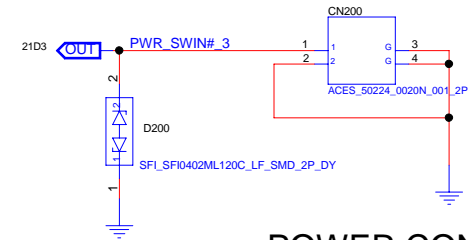
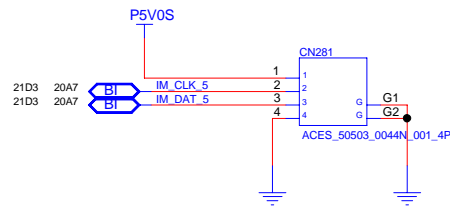
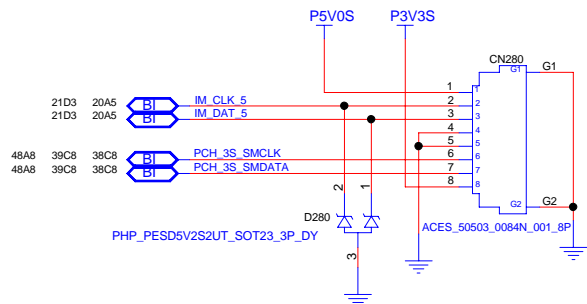
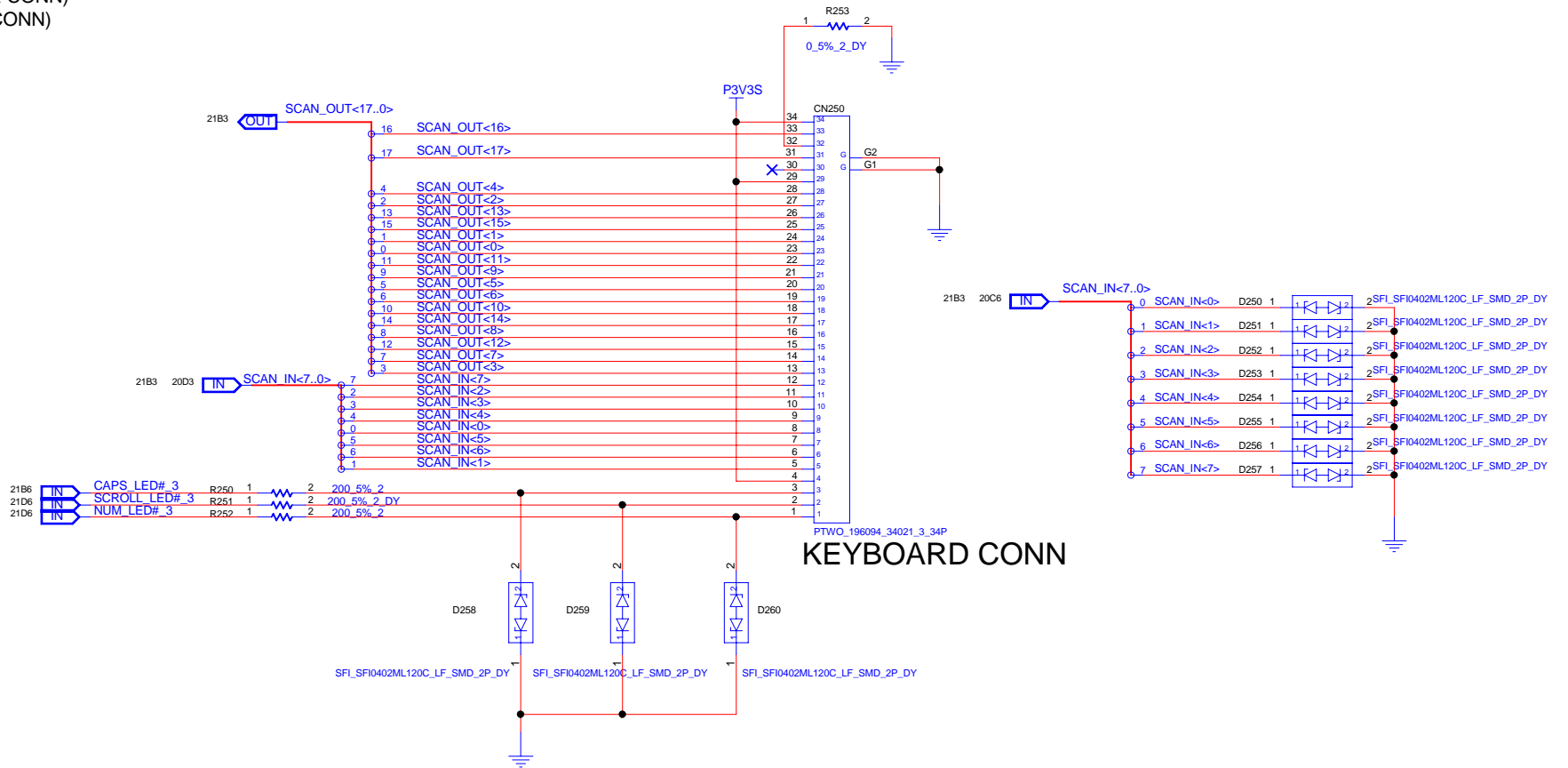

INVENTEC

TITLE			
MODEL PROJECT FUNCTION			
Block Diagram			
SIZE	CODE	DOC NUMBER	REV
A3	CS	1310xxxxx-0-0	X01

REFERENCE 300~389(KBC)

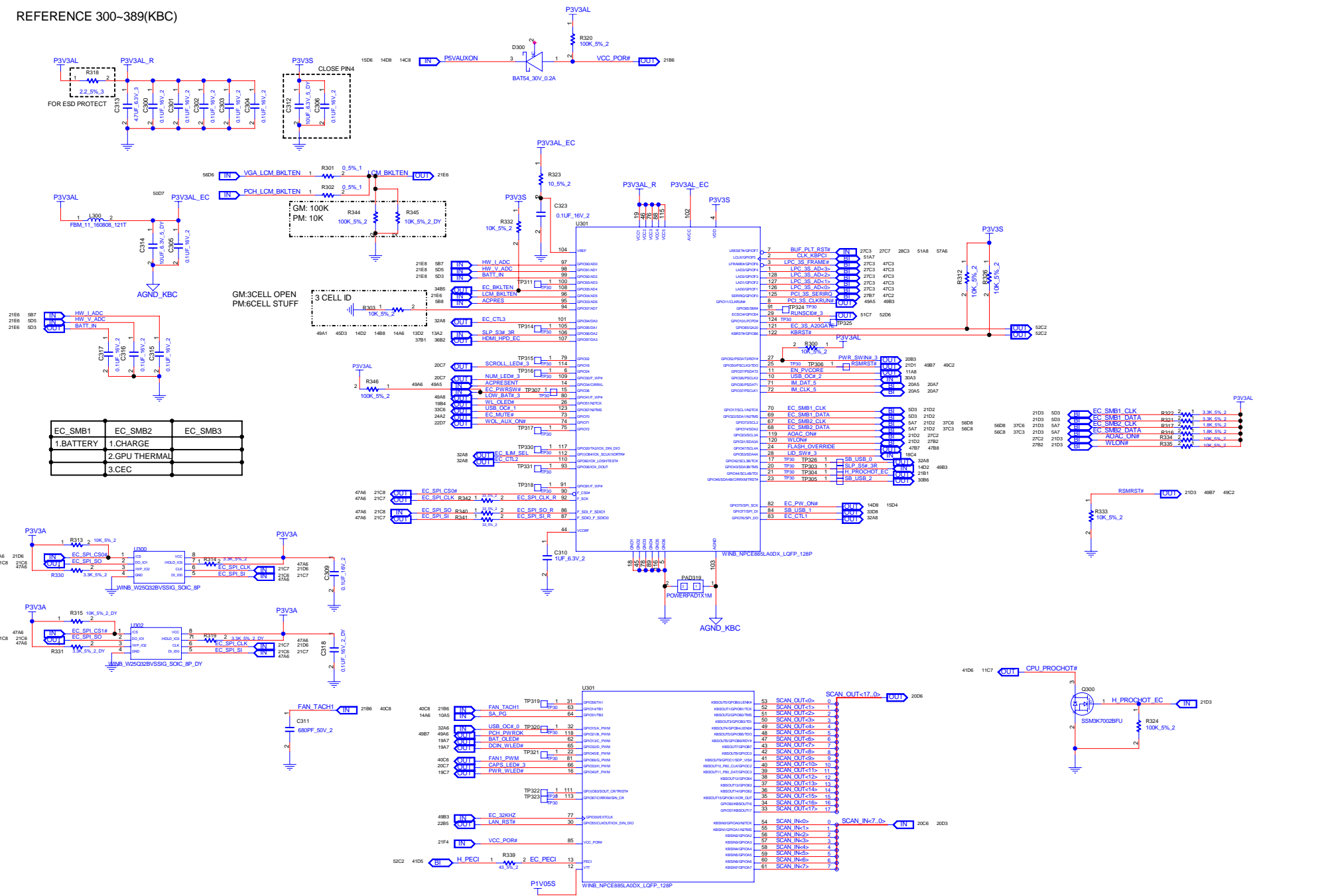

EC_SMB1	EC_SMB2	EC_SMB3
1.BATTERY	1.CHARGE	
	2.GPU THERMAL	
	3.CEC	

INVENTEC

FILE: MODEL\PROJECT\FUNCTION
Block Diagram

SIZE	CODE	DOC NUMBER	REV
C	CS	131000000000	201

SHEET 31 of 39

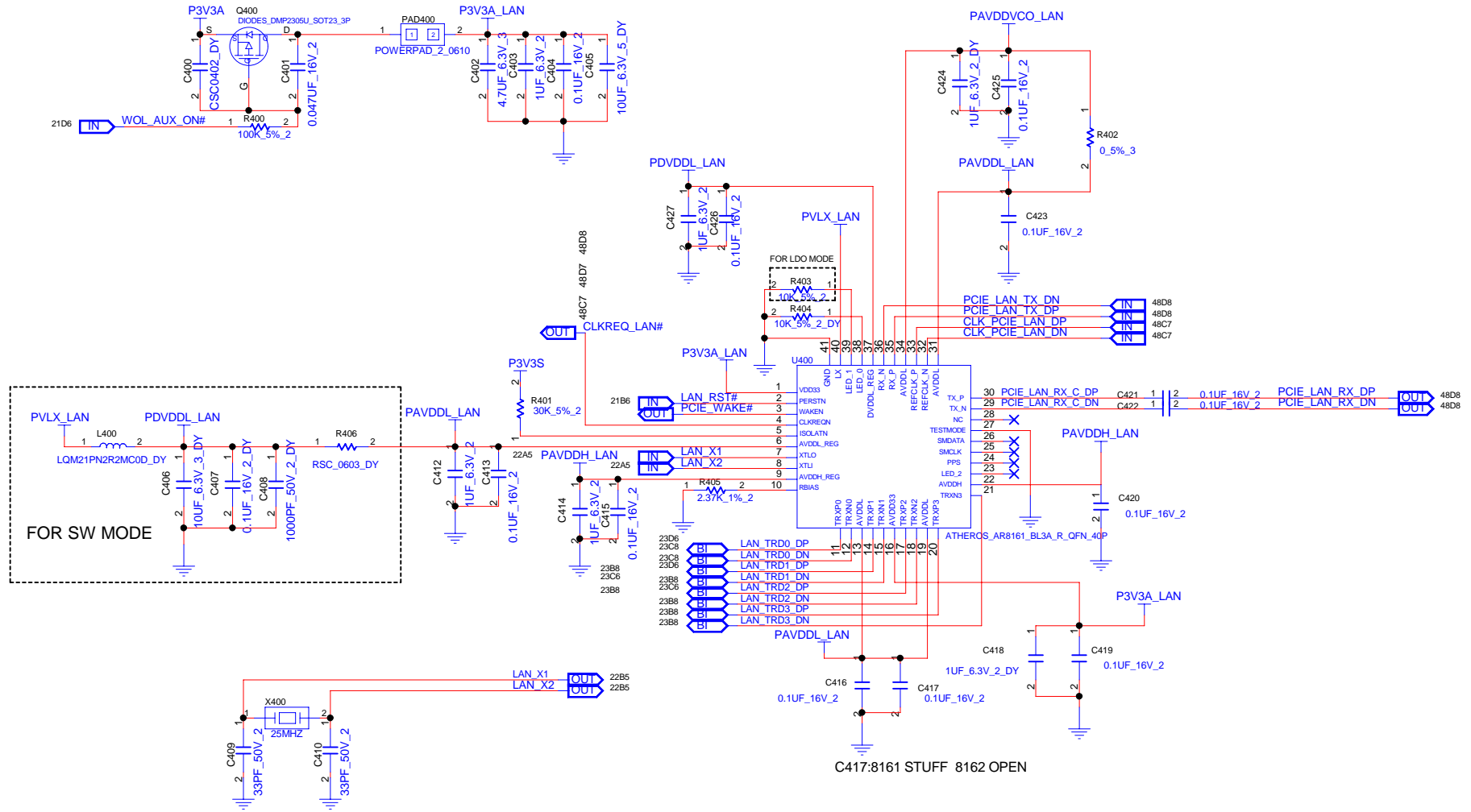

INVENTEC

TITLE			
MODEL PROJECT FUNCTION Block Diagram			
SIZE A3	CODE CS	DOC NUMBER 1310xxxx-0-0	REV X01

REFERENCE 400-499(LAN)

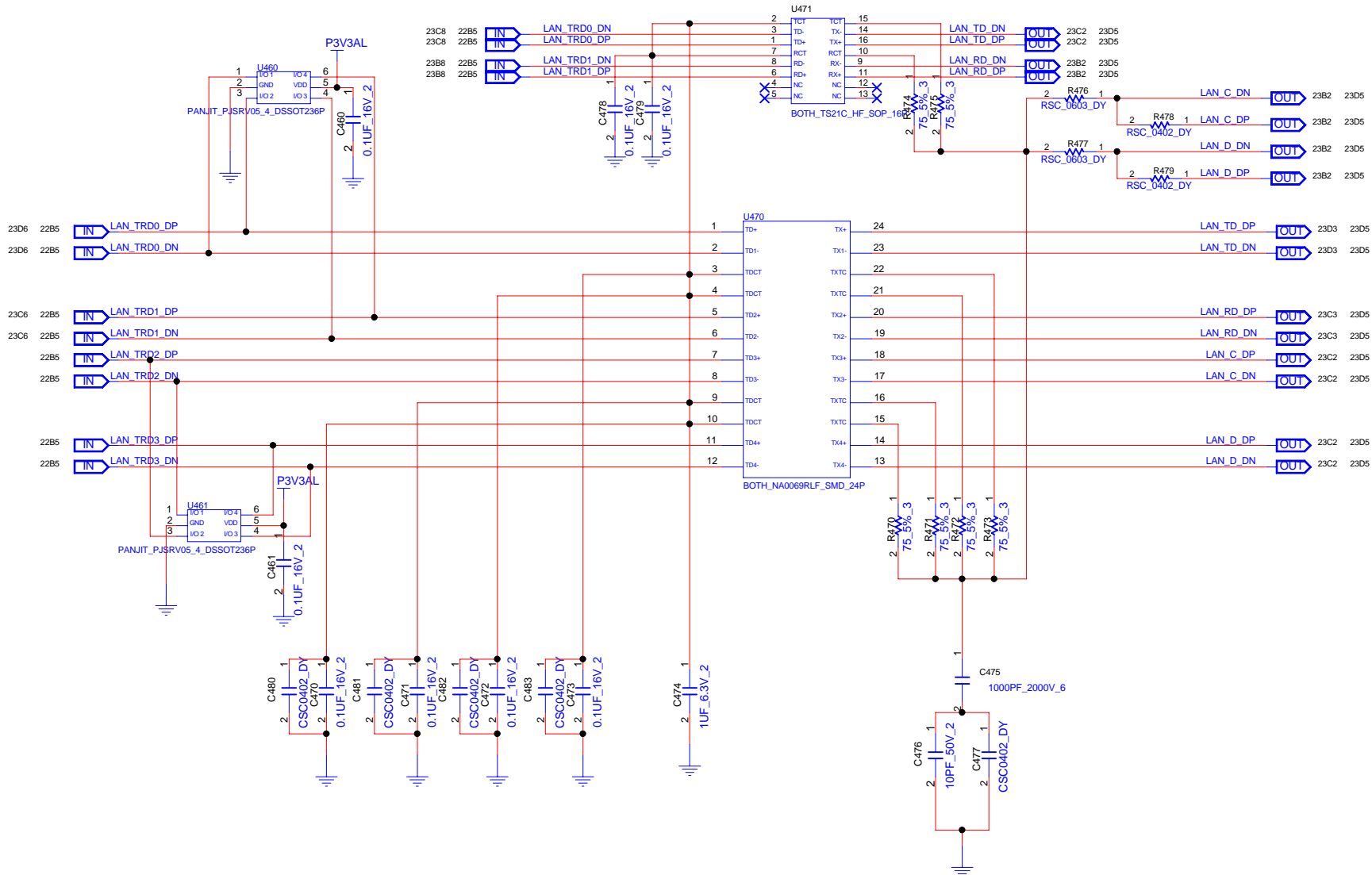
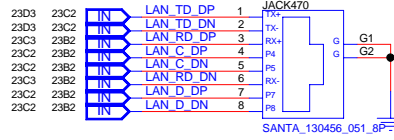

INVENTEC			
TITLE			
MODEL PROJECT FUNCTION			
Block Diagram			
SIZE	CODE	DOC NUMBER	REV
A3	CS	1310xxxx-0-0	X01
CHANGE by		DATE	SHEET
XXX		21-OCT-2002	23 of 70

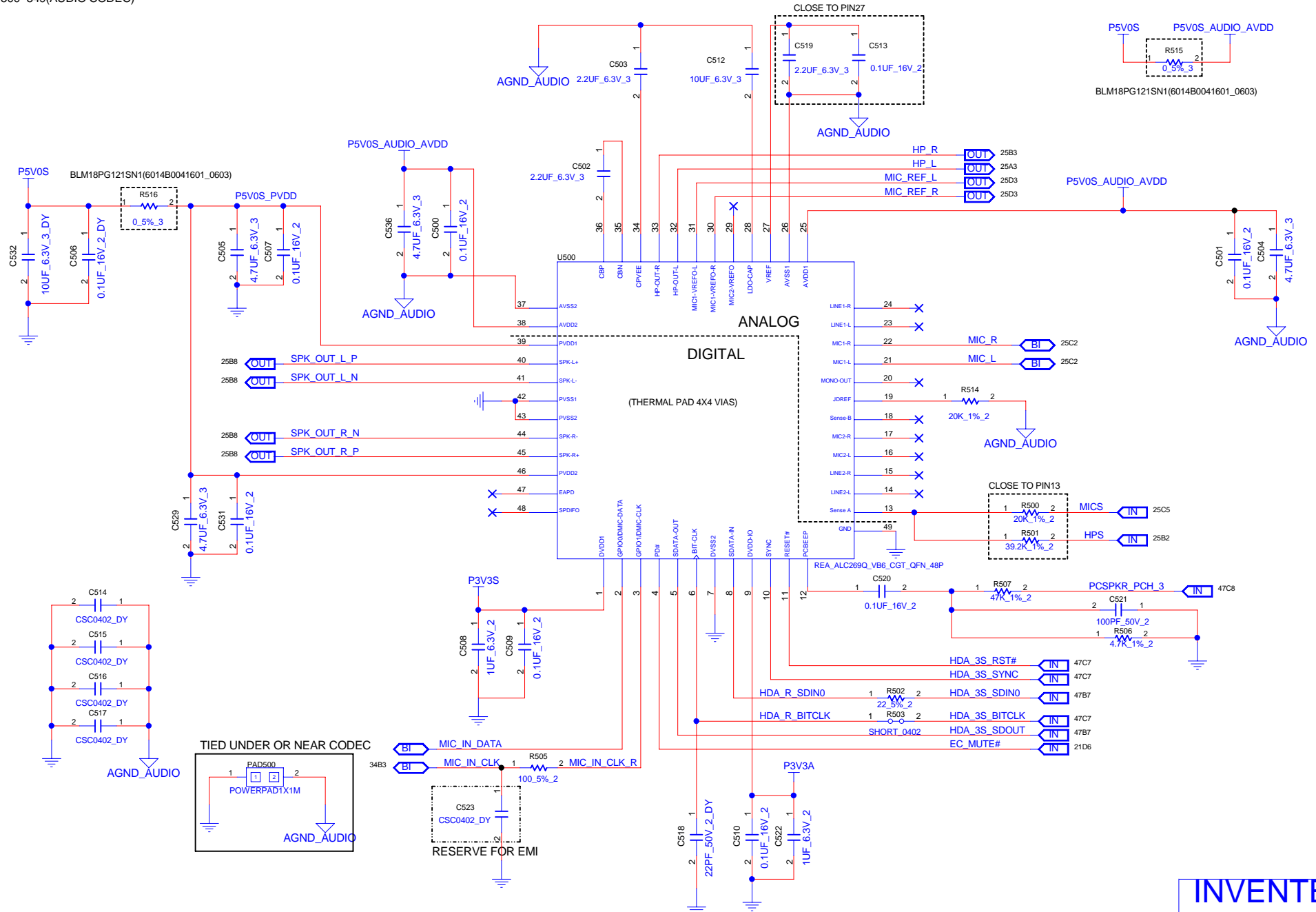

INVENTEC			
TITLE			
MODEL PROJECT FUNCTION			
Block Diagram			
SIZE A3	CODE CS	DOC NUMBER 1310xxxx-0-0	REV X01
CHANGE by XXX		DATE 21-OCT-2002	SHEET 24 of 70

AUDIO JACKS

MICPHONE

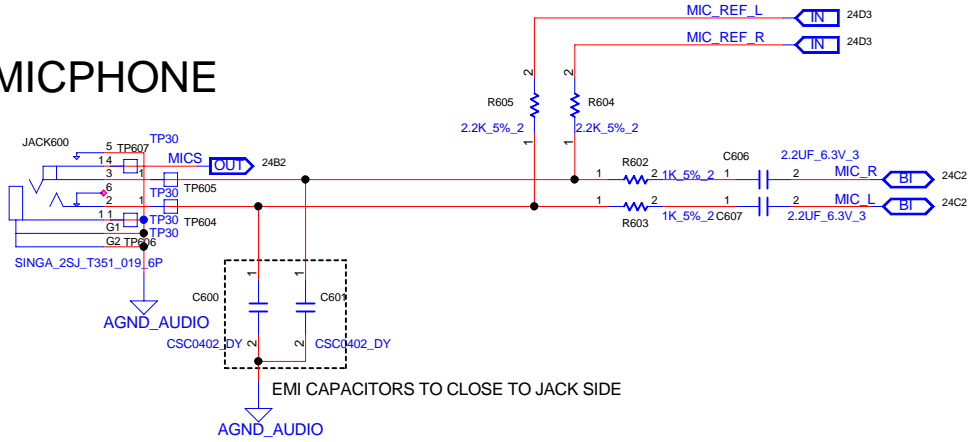

INTERNAL SPEAKERS

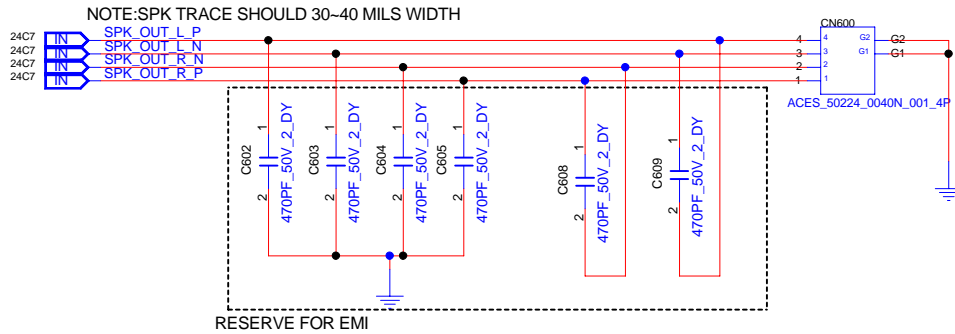

HEADPHONE

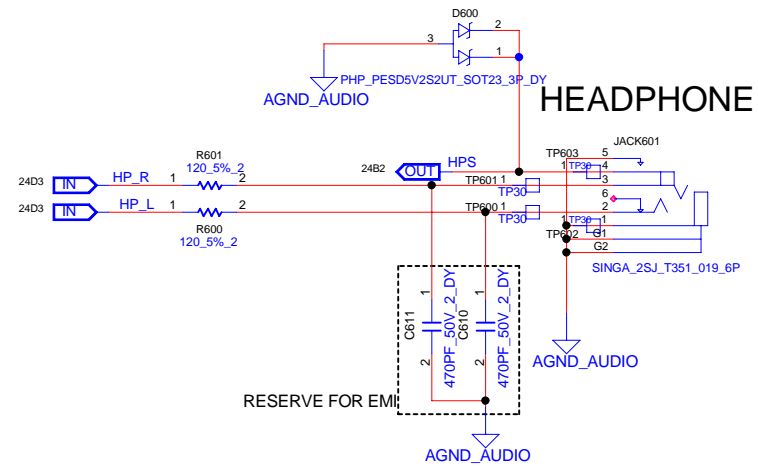

INVENTEC

TITLE			
MODEL PROJECT FUNCTION			
Block Diagram			
SIZE	CODE	DOC NUMBER	REV
A3	CS	1310xxxx-0-0	X01

REFERNCE 900~999(CARDREADER)

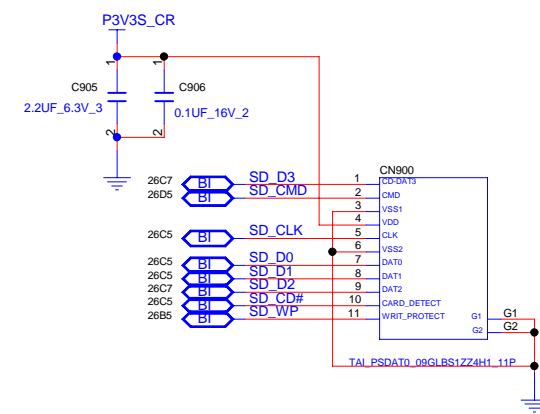
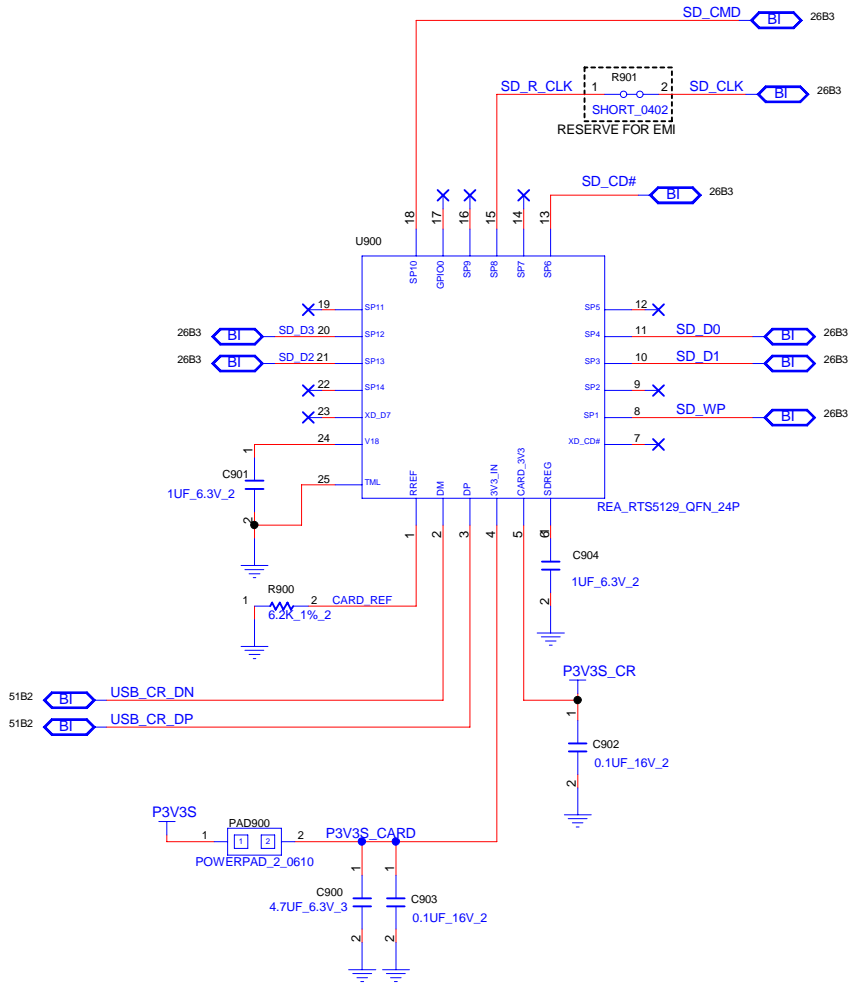

INVENTEC			
TITLE			
MODEL PROJECT.FUNCTION Block Diagram			
SIZE A3	CODE CS	DOC NUMBER 1310xxxxx-0-0	REV X01

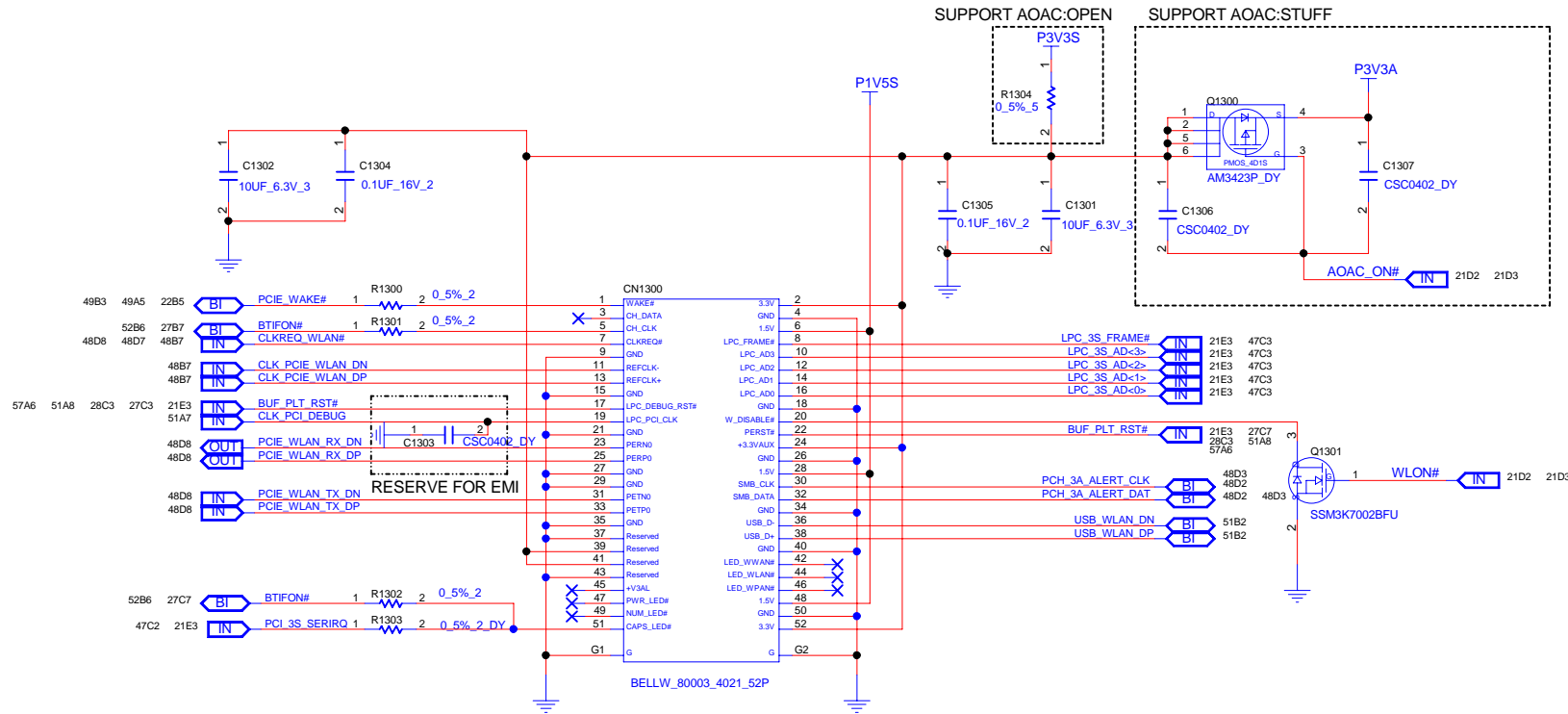

MINI CARD 1(WLAN)

INVENTEC			
TITLE			
MODEL, PROJECT, FUNCTION Block Diagram			
SIZE A3	CODE CS	DOC NUMBER 1310xxxxx-0-0	REV X01

REFERENCE 1400~1499(3G)

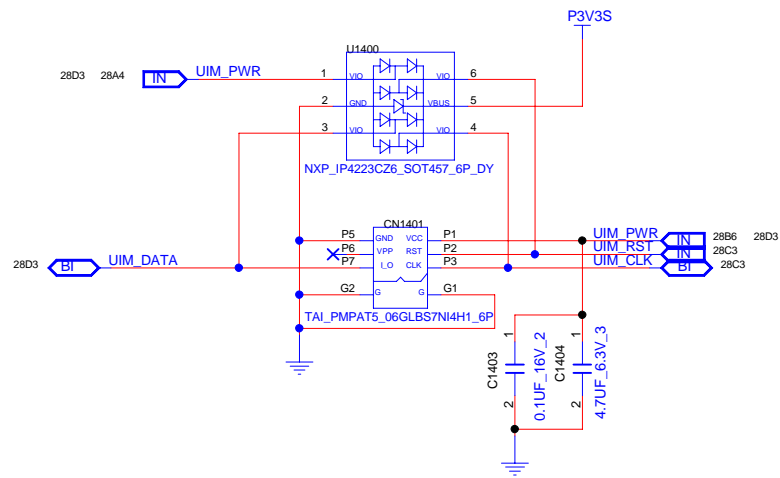
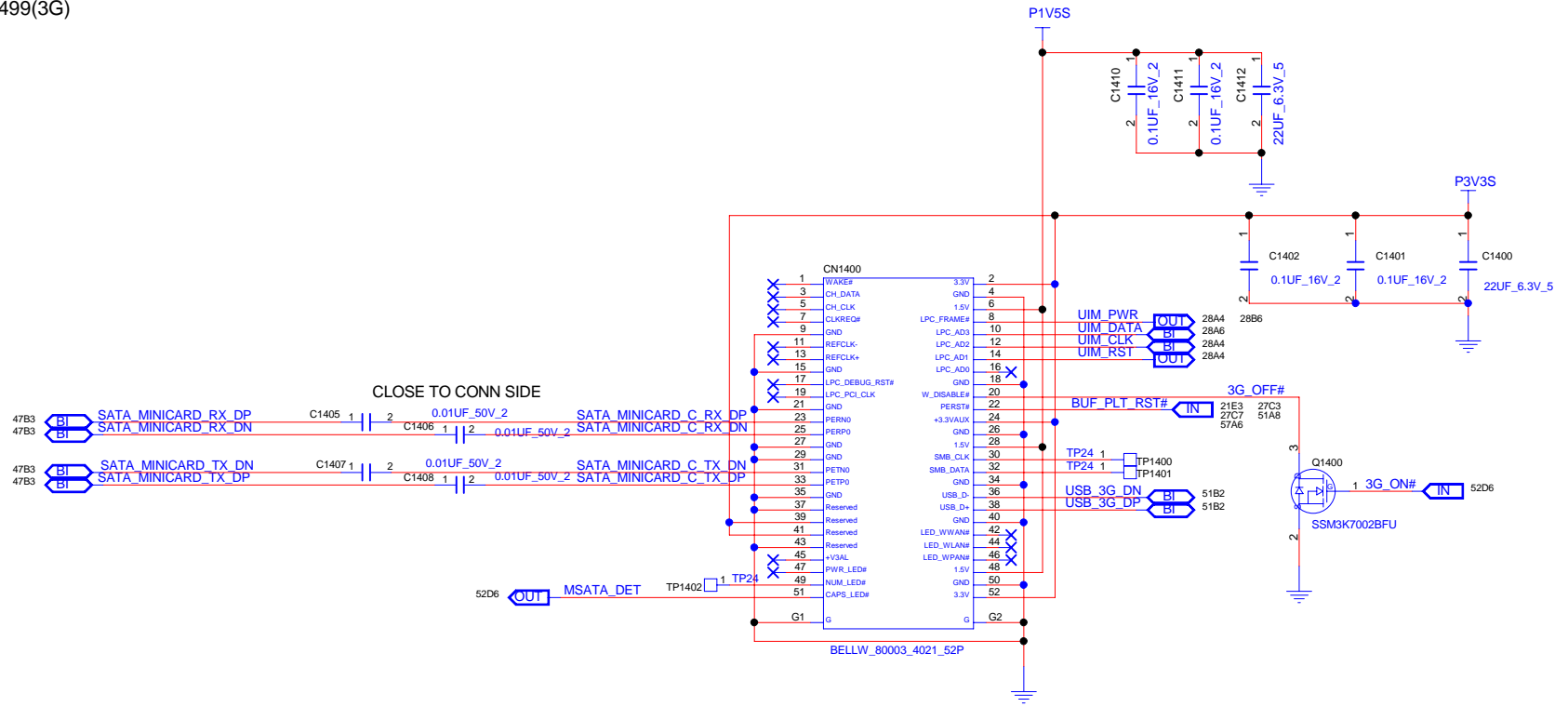

INVENTEC

TITLE			
MODEL,PROJECT,FUNCTION			
Block Diagram			
SIZE A3	CODE CS	DOC NUMBER 1310xxxx-0-0	REV X01

REFERENCE 1700~1749(HDD)
 REFERENCE 1750~1799(ODD)

SATA HDD

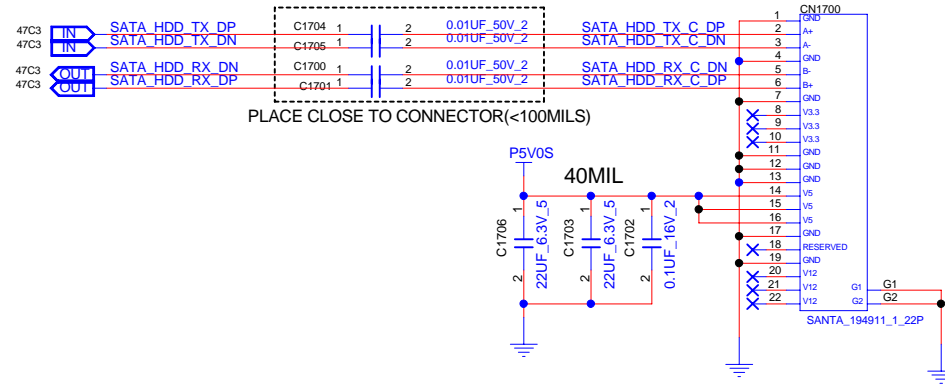

SATA ODD

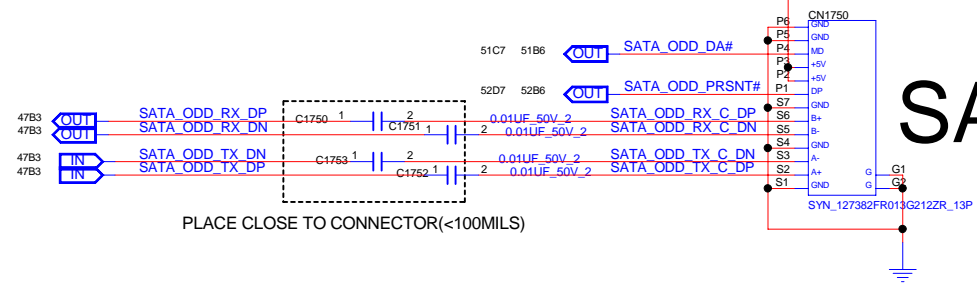

INVENTEC			
TITLE			
MODEL,PROJECT,FUNCTION Block Diagram			
SIZE A3	CODE CS	DOC NUMBER 1310xxxx-0-0	REV X01
CHANGE by XXX		DATE 21-OCT-2002	SHEET 29 of 70

REFERENCE 2000~2099(USB)

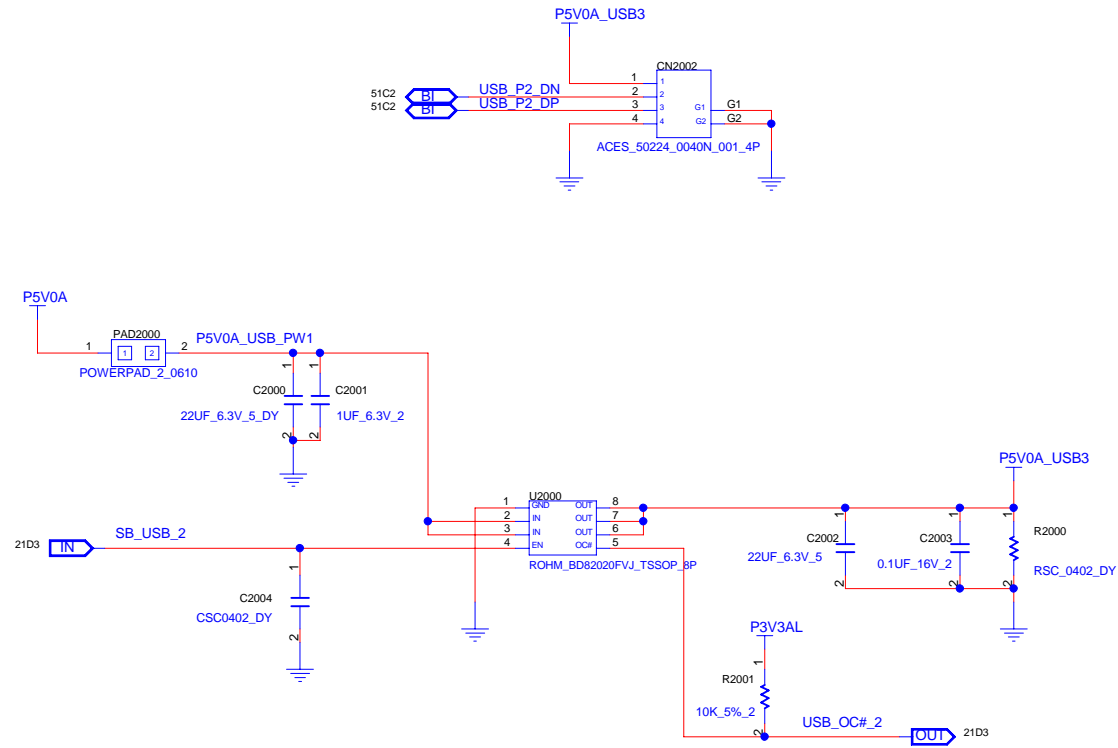

INVENTEC

TITLE			
MODEL PROJECT.FUNCTION Block Diagram			
SIZE A3	CODE CS	DOC NUMBER 1310xxxx-0-0	REV X01

REFERENCE 2400~2499

REMOVE USB3.0 CONTROLLER IC

D
C
B
A

D
C
B
A

INVENTEC			
TITLE			
MODEL, PROJECT, FUNCTION Block Diagram			
SIZE A3	CODE CS	DOC. NUMBER 1310xxxx-0-0	REV X01

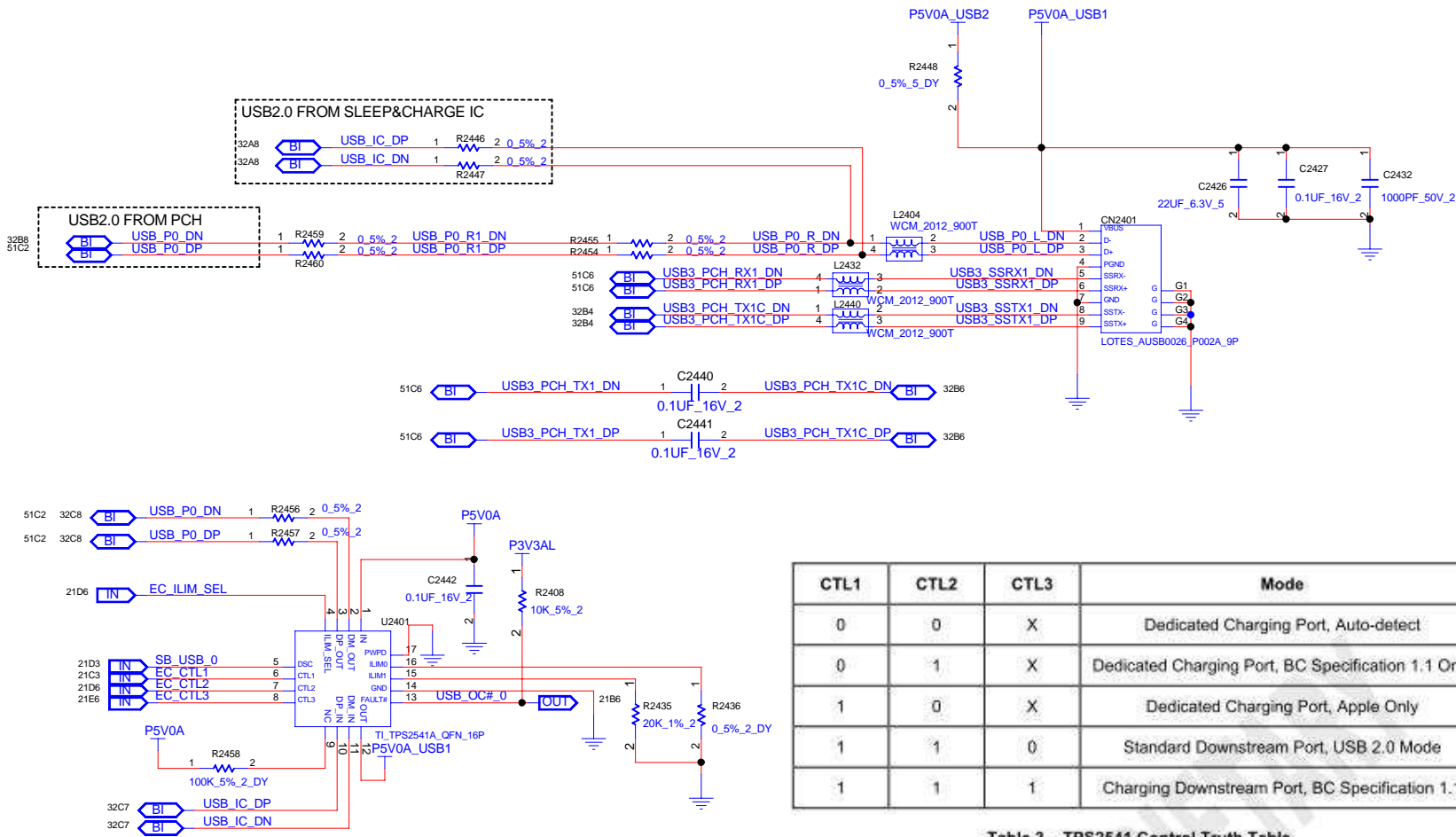

CTL1	CTL2	CTL3	Mode
0	0	X	Dedicated Charging Port, Auto-detect
0	1	X	Dedicated Charging Port, BC Specification 1.1 Only
1	0	X	Dedicated Charging Port, Apple Only
1	1	0	Standard Downstream Port, USB 2.0 Mode
1	1	1	Charging Downstream Port, BC Specification 1.1

Table 3 – TPS2541 Control Truth Table

INVENTEC

TITLE			
MODEL,PROJECT,FUNCTION			
Block Diagram			
SIZE	CODE	DOC NUMBER	REV
A3	CS	1310xxxx-0-0	X01

USB 3.0 CONNECTOR

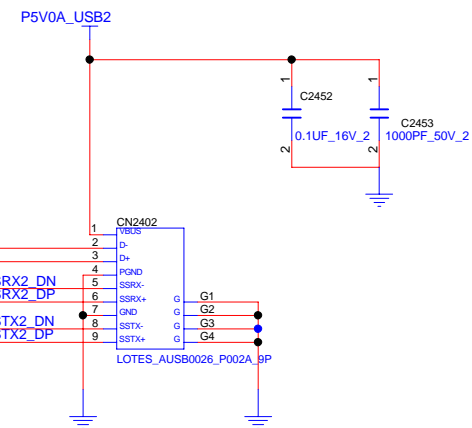
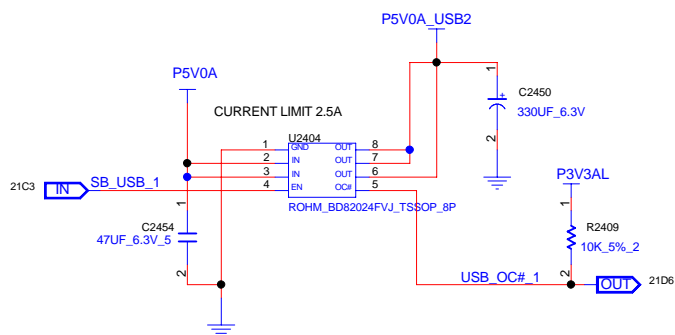

USB2.0 FROM PCH

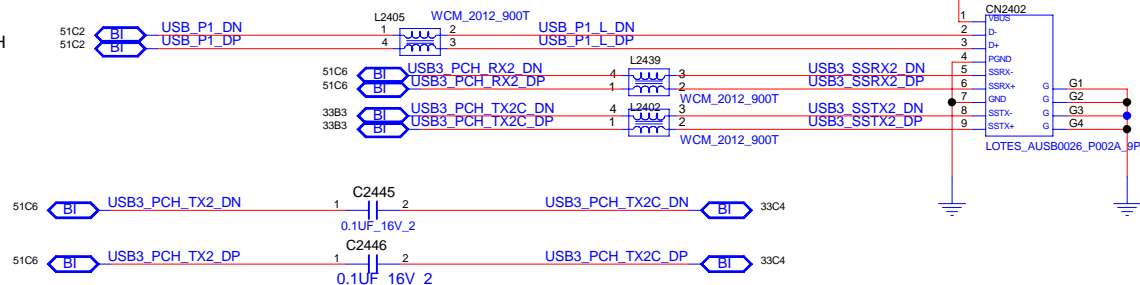

INVENTEC			
TITLE			
MODEL PROJECT.FUNCTION Block Diagram			
SIZE A3	CODE CS	DOC NUMBER 1310xxxxx-0-0	REV X01

REFERENCE 3000~3049(LCM)

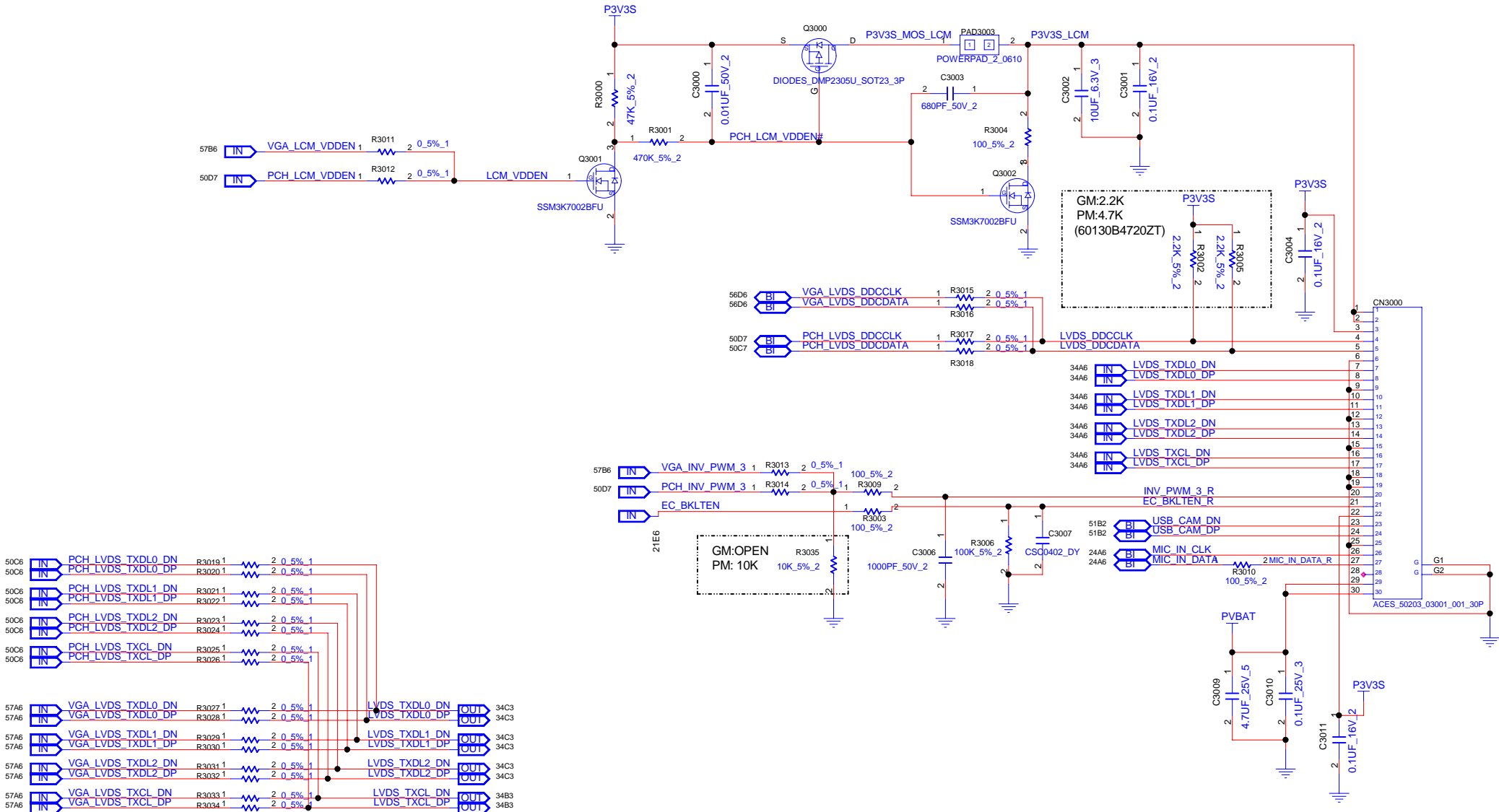

INVENTEC

TITLE			
MODEL PROJECT FUNCTION			
Block Diagram			
SIZE	CODE	DOC NUMBER	REV
A3	CS	1310xxxx-0-0	X01

REFERENCE 3050~3099(CRT)

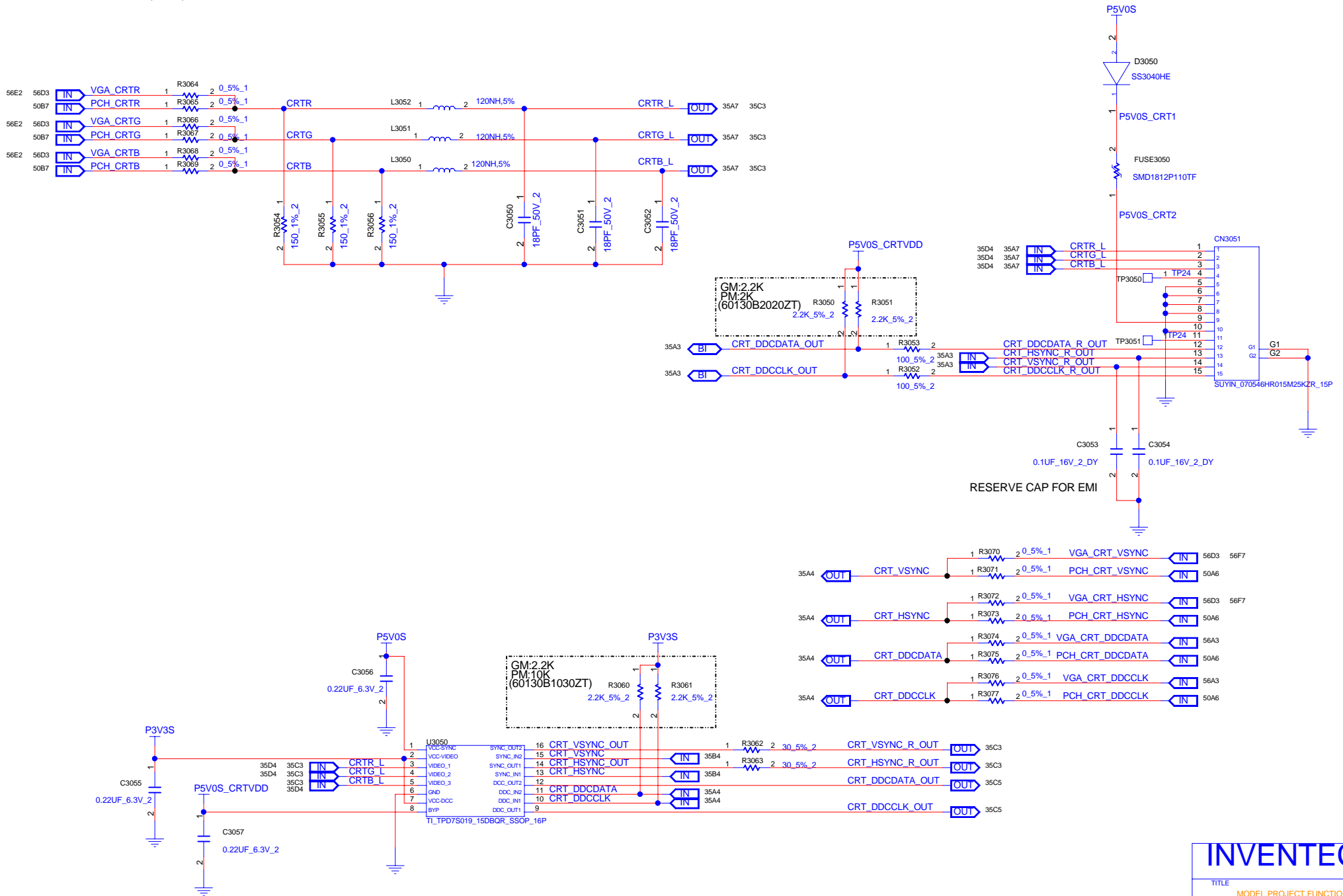

INVENTEC

TITLE			
MODEL PROJECT FUNCTION			
Block Diagram			
SIZE	CODE	DOC NUMBER	REV
A3	CS	1310xxxx-0-0	X01

REFERENCE 3150~3199(HDMI)

PLACE CLOSE TO CONNECTOR

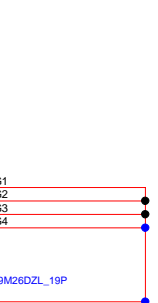
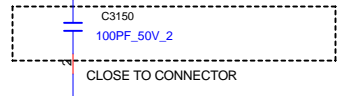
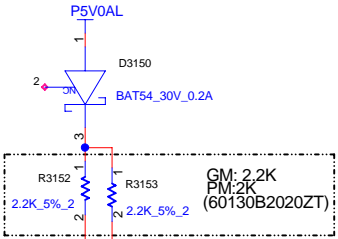
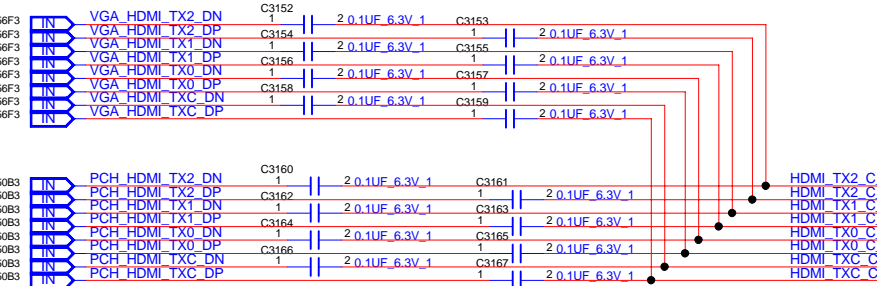
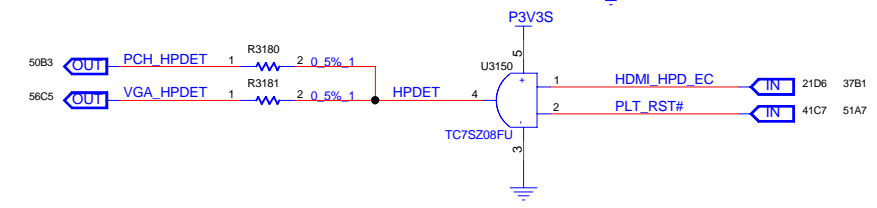
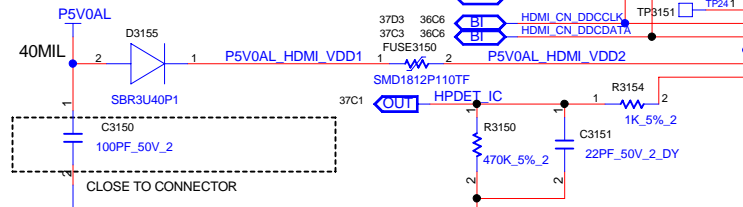
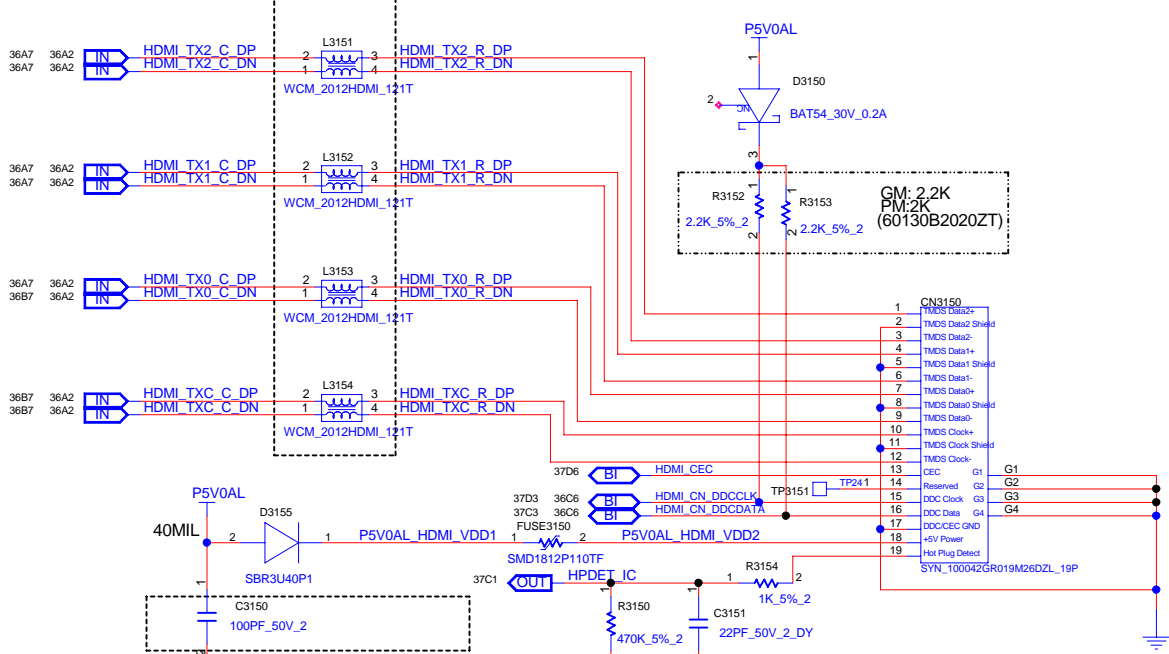
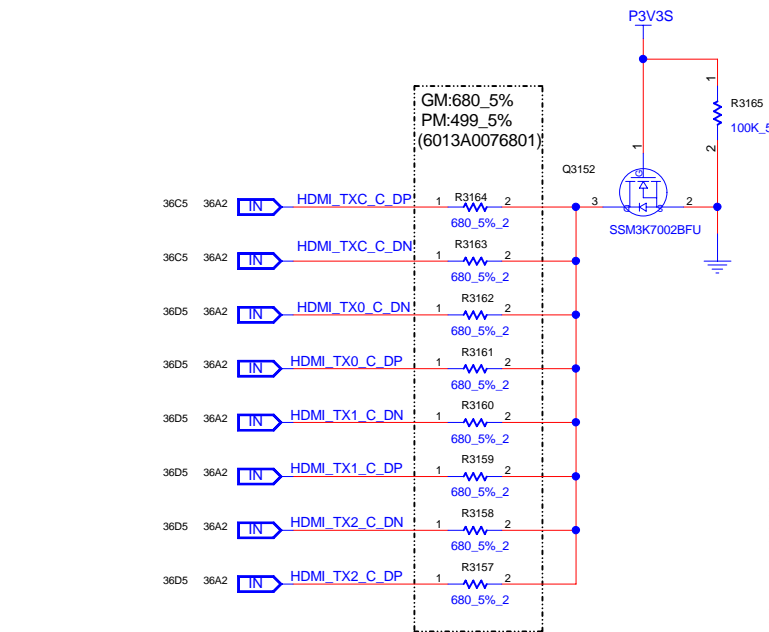
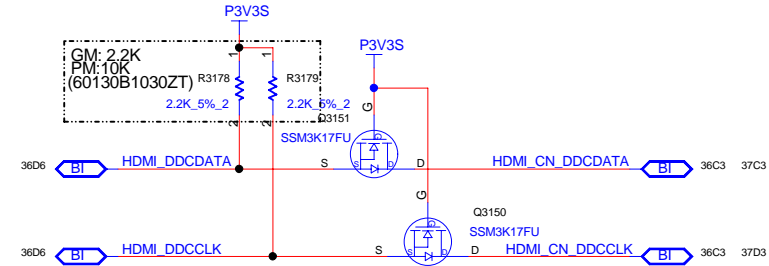
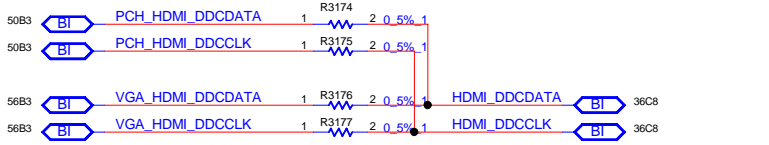

INVENTEC
 TITLE
 MODEL,PROJECT,FUNCTION
 Block Diagram

DOC NUMBER
 1310xxxx-0-0
 REV
 X01

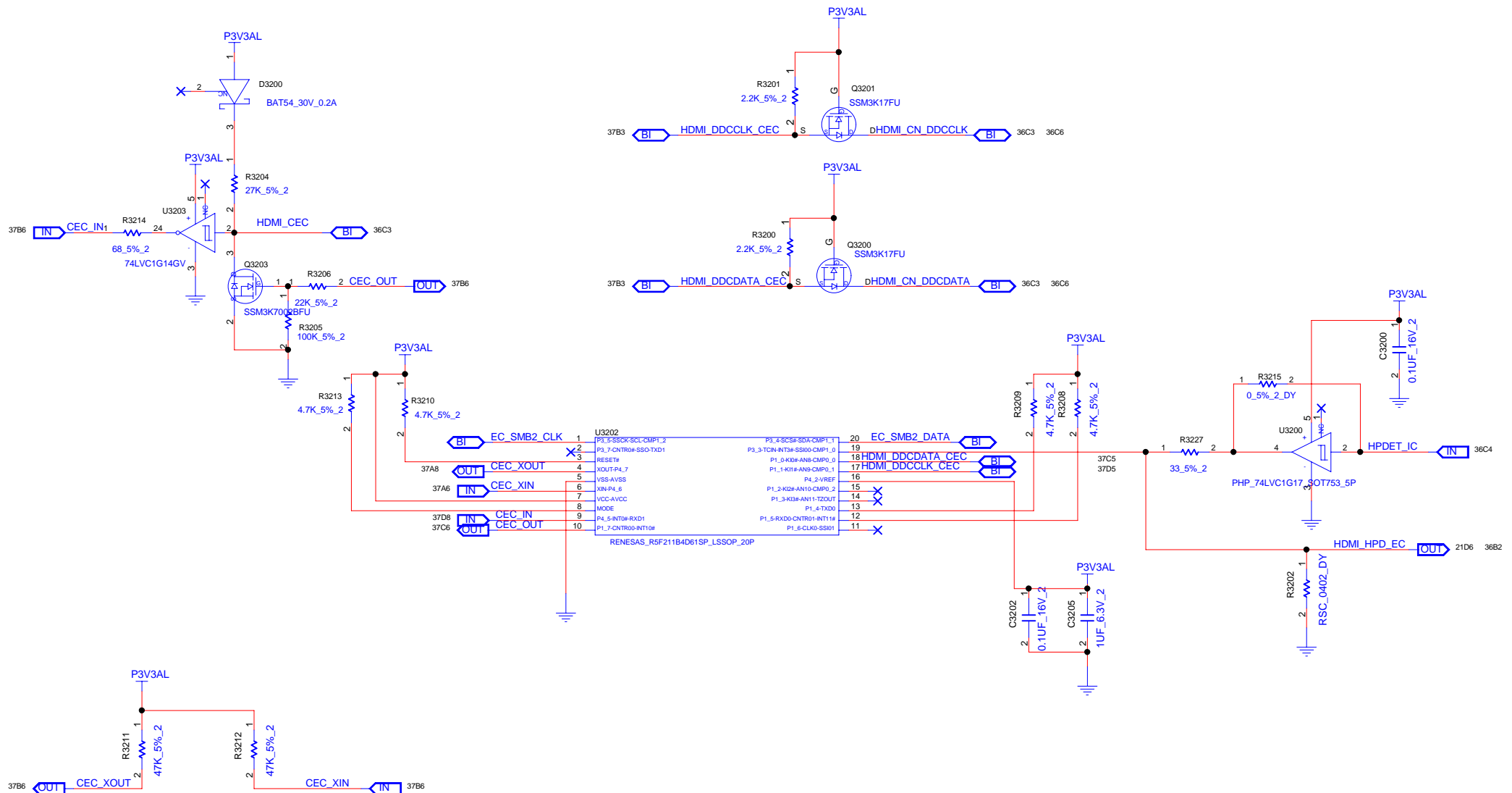

INVENTEC			
TITLE			
MODEL PROJECT FUNCTION Block Diagram			
SIZE A3	CODE CS	DOC NUMBER 1310xxxx-0-0	REV X01

CHA

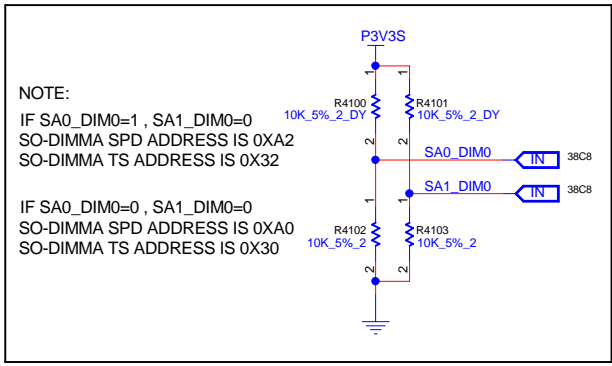
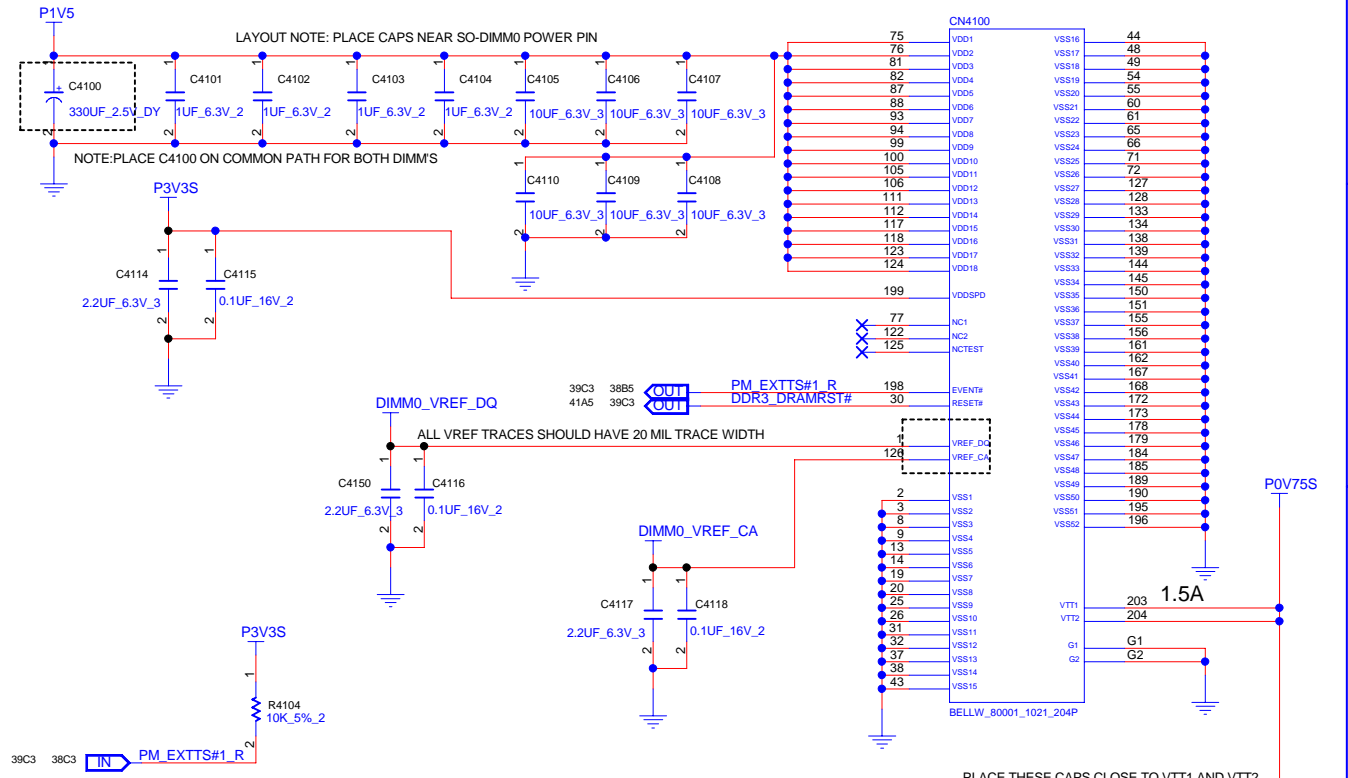
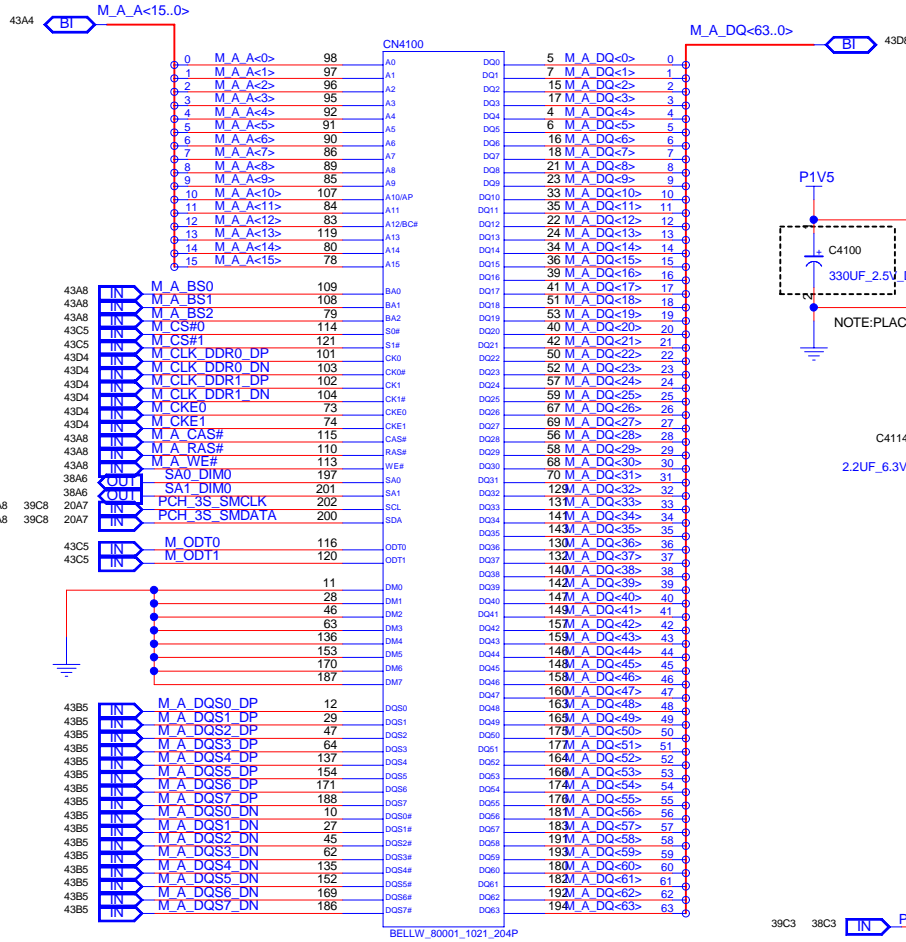

INVENTEC

TITLE			
MODEL PROJECT FUNCTION			
Block Diagram			
SIZE A3	CODE CS	DOC NUMBER 1310xxxx-0-0	REV X01
CHANGE by XXX		DATE 21-OCT-2002	SHEET 38 of 70

CHB

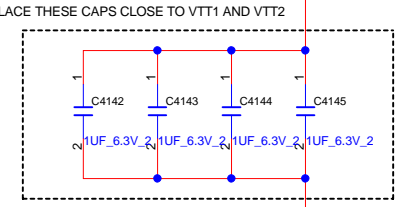
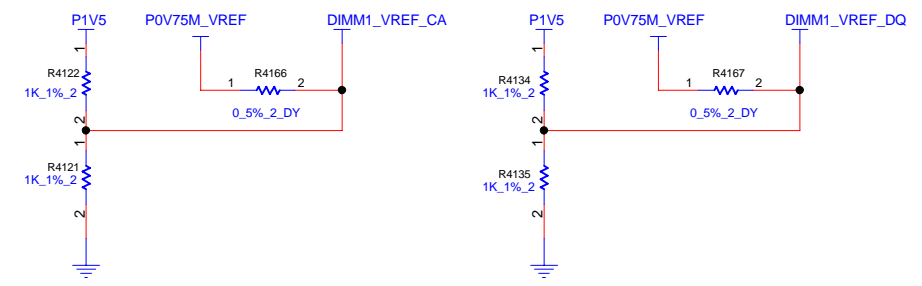
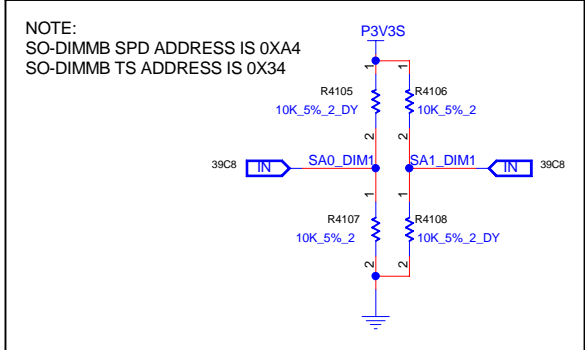
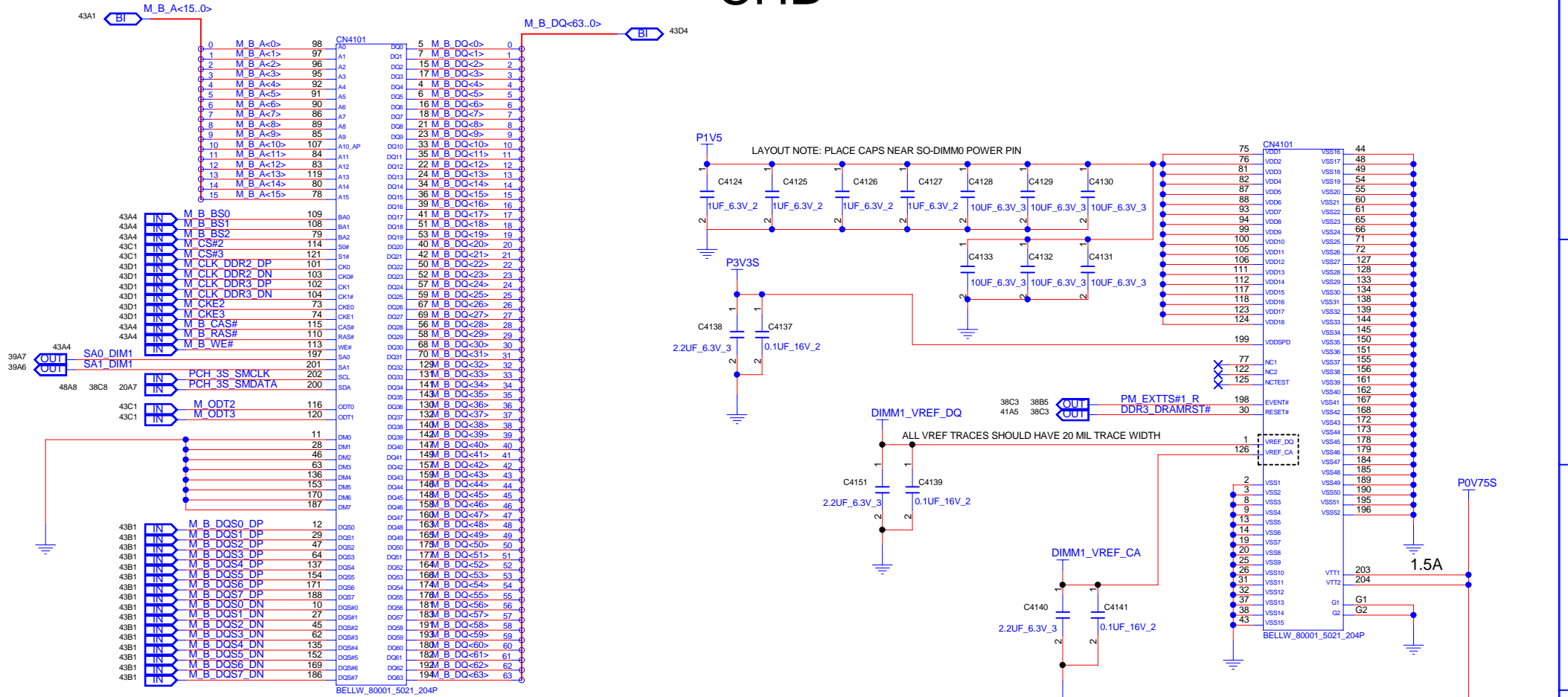

INVENTEC

TITLE			
MODEL PROJECT FUNCTION			
Block Diagram			
SIZE	CODE	DOC NUMBER	REV
A3	CS	1310xxxx-0-0	X01

CHANGE by XXX DATE 21-OCT-2002 SHEET 39 of 70

REFERENCE 4300~4349(FAN)
 REFERENCE 4411~4449(THERMAL)

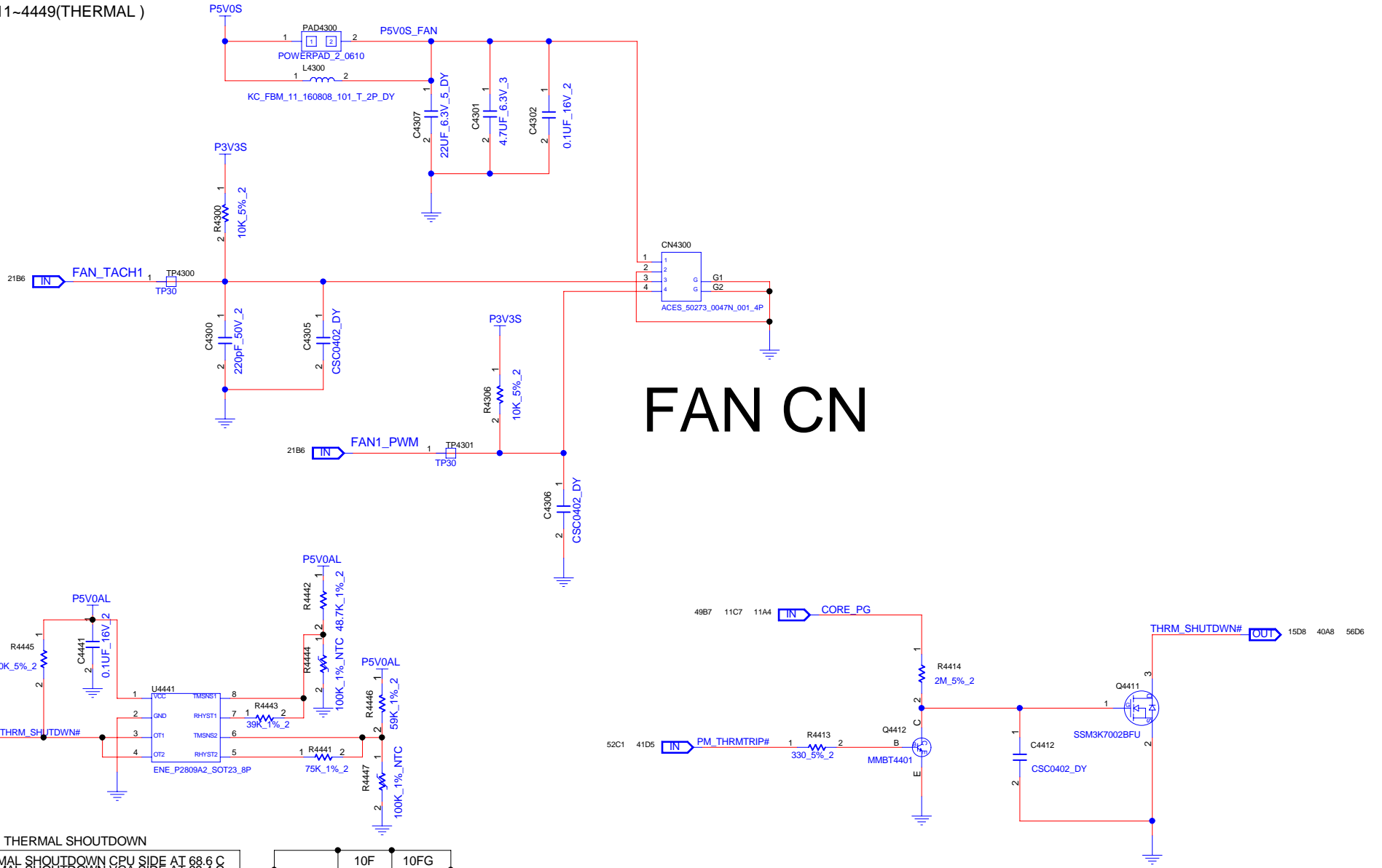

FAN CN

THERMAL SHUTDOWN
 GM THERMAL SHUTDOWN CPU SIDE AT 68.6 C
 GM THERMAL SHUTDOWN VGA SIDE AT 63.4 C
 PM THERMAL SHUTDOWN CPU SIDE AT 71.9 C
 PM THERMAL SHUTDOWN VGA SIDE AT 80.2 C

	10F	10FG
R4442	48.7K	43.2K
R4443	39K	30.1K
R4446	59K	32.4K
R4441	75K	18.2K

INVENTEC

TITLE: MODEL,PROJECT,FUNCTION
 Block Diagram

SIZE A3 CODE CS DOC NUMBER 1310xxxxx-0-0 REV X01

CHANGE by XXX DATE 21-OCT-2002 SHEET 40 of 70

REFERENCE 4500-4699(CPU)

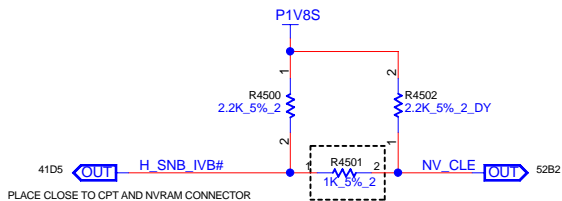

PROCESS STRAP SETTING

SANDY BRIDGE ONLY	STUFF R4502
SANDY BRIDGE/IVY BRIDGE	STUFF R4500/R4501

DMI&FDI TERMINATIONVOLTAGE

NV_CLE	SET TOVSS WHEN LOW (DEFAULT) SET TOVCC WHEN HIGH
--------	---

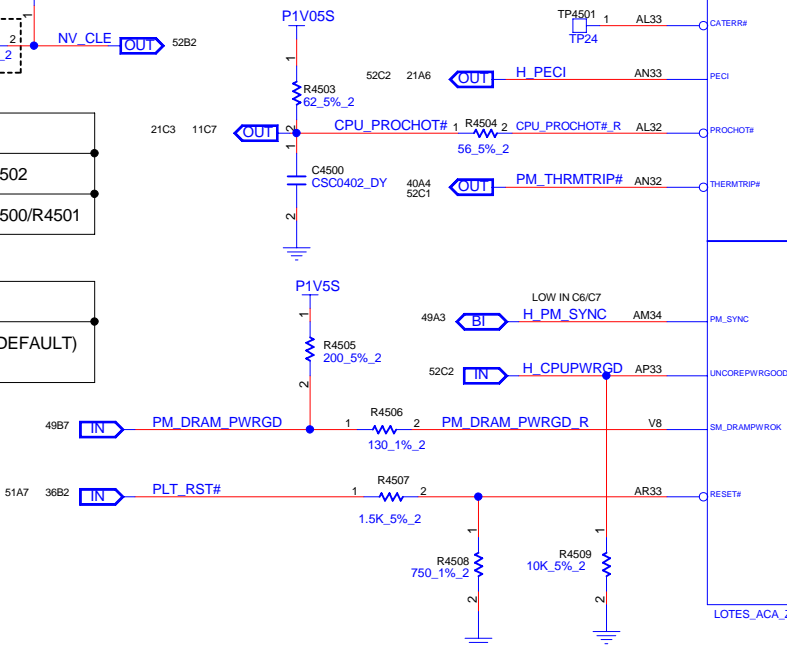

LOTES_ACA_ZIF_069_P01_989P

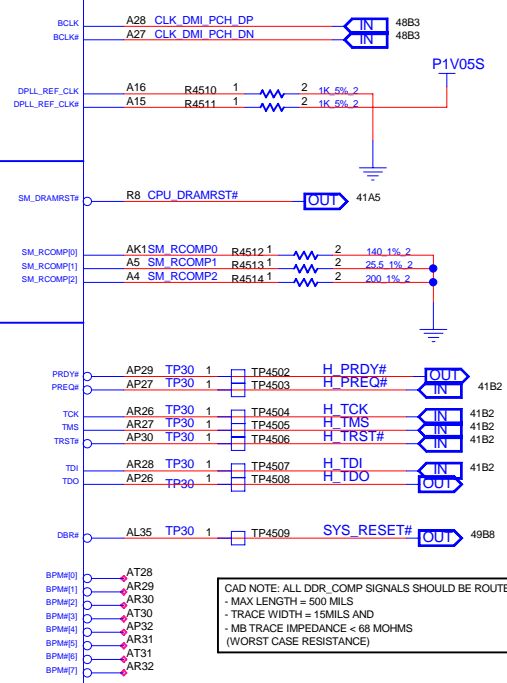
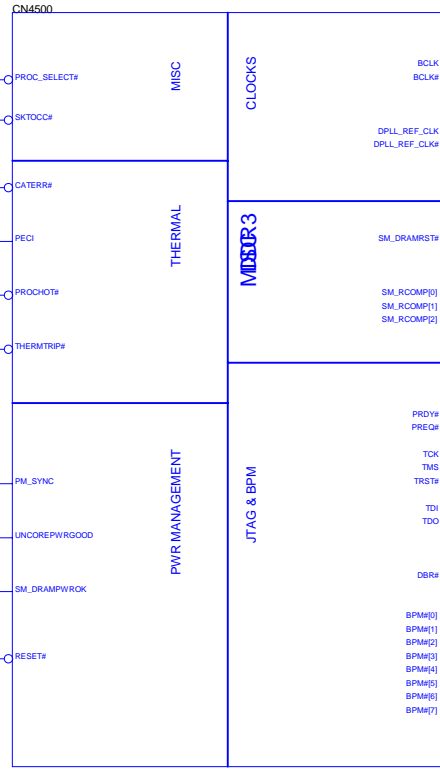

CAD NOTE: ALL DDR_COMP SIGNALS SHOULD BE ROUTED SUCH THAT
 - MAX LENGTH = 500 MILS
 - TRACE WIDTH = 15MILS AND
 - MB TRACE IMPEDANCE = 68 MOHMS
 (WORST CASE RESISTANCE)

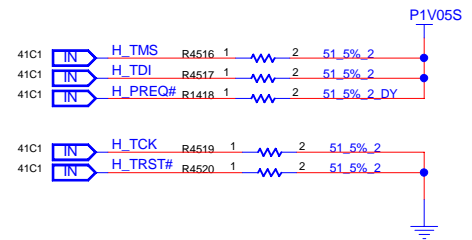

S3 CIRCUIT: DRAM_RST# TO MEMORY SHOULD BE HIGH DURING S3

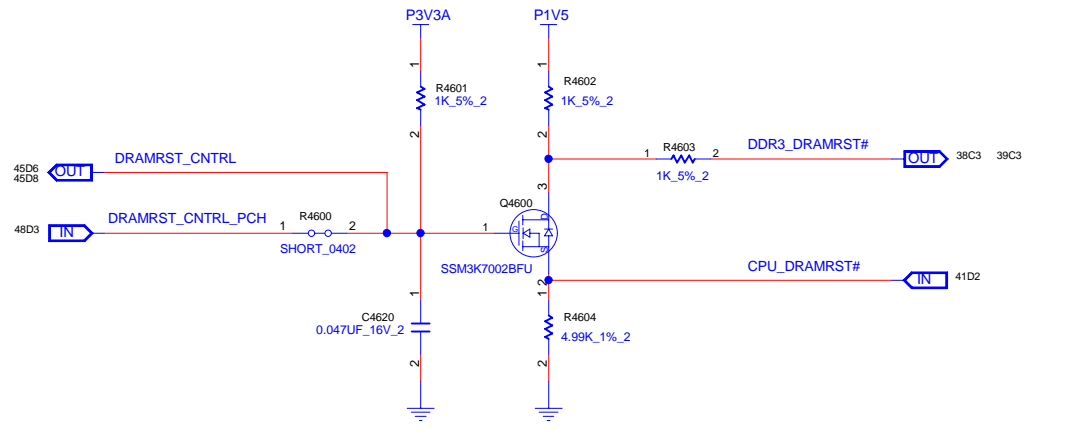

INVENTEC

TITLE: MODEL,PROJECT,FUNCTION
Block Diagram

SIZE A3	CODE CS	DOC NUMBER 1310xxxxx-0-0	REV X01
---------	---------	--------------------------	---------

CHANGE by XXX DATE 21-OCT-2002 SHEET 41 of 70

REFERENCE 4500~4699(CPU)

CAD NOTE: PEG_ICOMPI AND RCOMPO SIGNALS SHOULD BE SHORTED AND ROUTED WITH
 - MAX LENGTH = 500 MILS
 - TYPICAL IMPEDANCE = 43 MOHMS

PEG_ICOMPO SIGNALS SHOULD BE ROUTED WITH
 - MAX LENGTH = 500 MILS
 - TYPICAL IMPEDANCE = 14.5 MOHMS

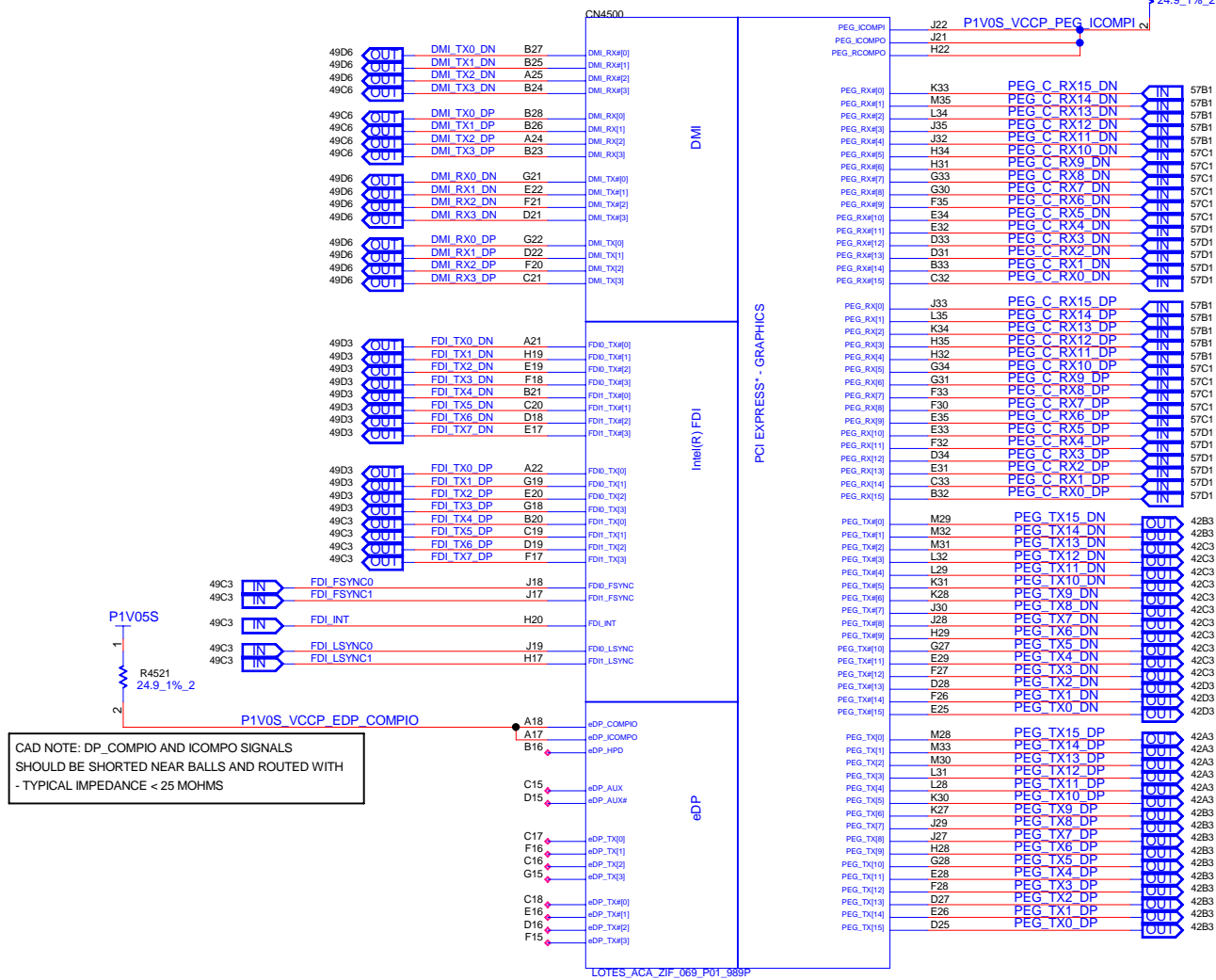

CAD NOTE: DP_COMPIO AND ICOMPO SIGNALS SHOULD BE SHORTED NEAR BALLS AND ROUTED WITH
 - TYPICAL IMPEDANCE < 25 MOHMS

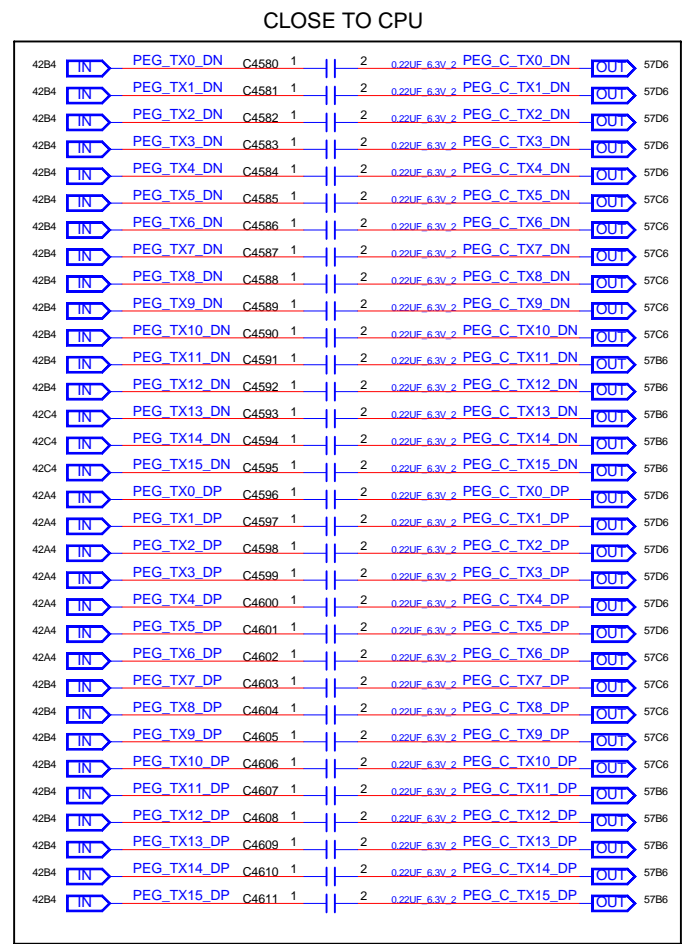

INVENTEC

TITLE: MODEL PROJECT.FUNCTION
Block Diagram

SIZE A3	CODE CS	DOC NUMBER 1310xxxxx-0-0	REV X01
---------	---------	--------------------------	---------

CHANGE by XXX DATE 21-OCT-2002 SHEET 42 of 70

REFERENCE 4500-4699(CPU)

SOCKET,CPU,989P,TIN,3.0MM,STR,SMD,TR

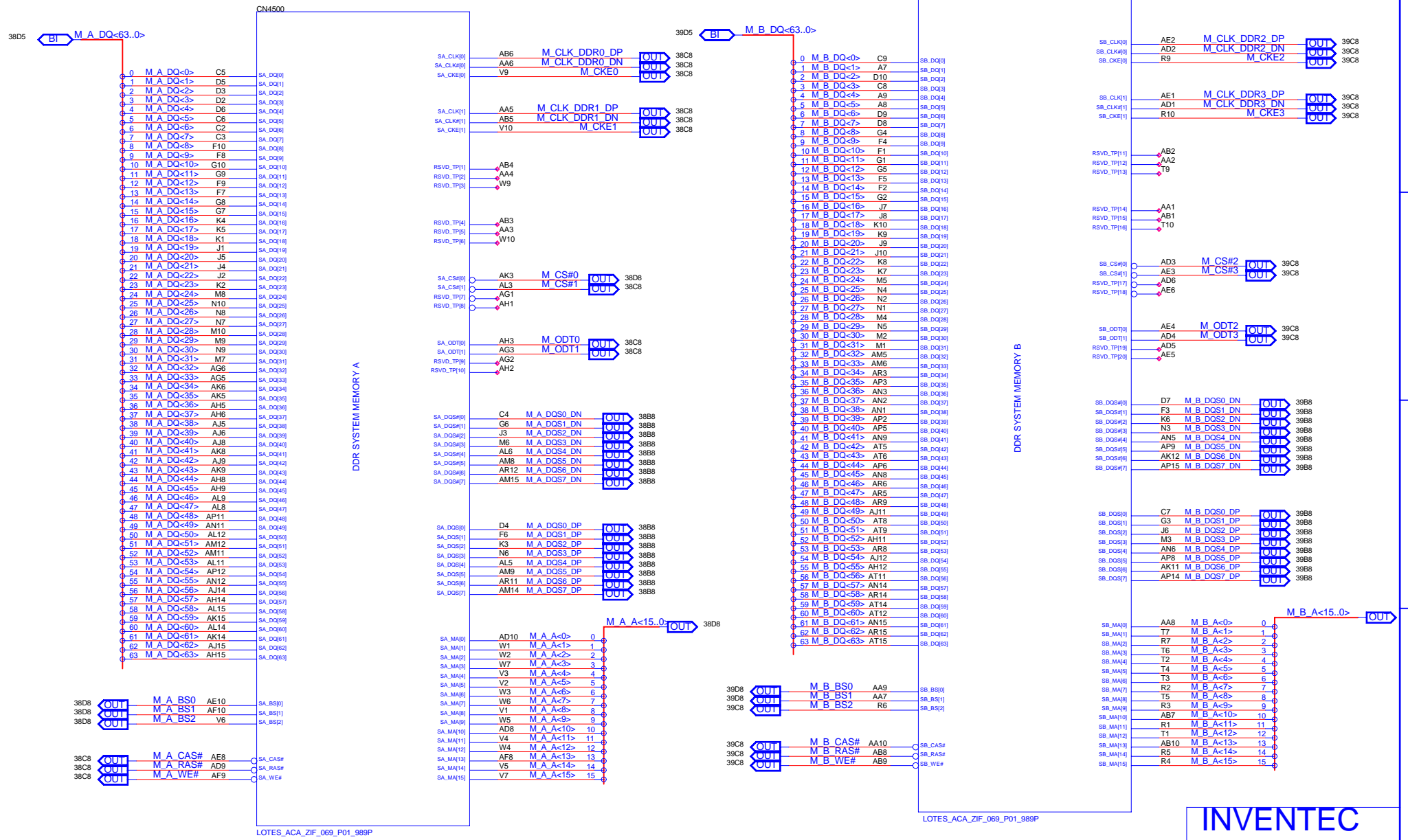

INVENTEC

TITLE
MODEL,PROJECT,FUNCTION
Block Diagram

SIZE	CODE	DOC NUMBER	REV
A3	CS	1310xxxx-0-0	X01

CHANGE by XXX DATE 21-OCT-2002 SHEET 43 of 70

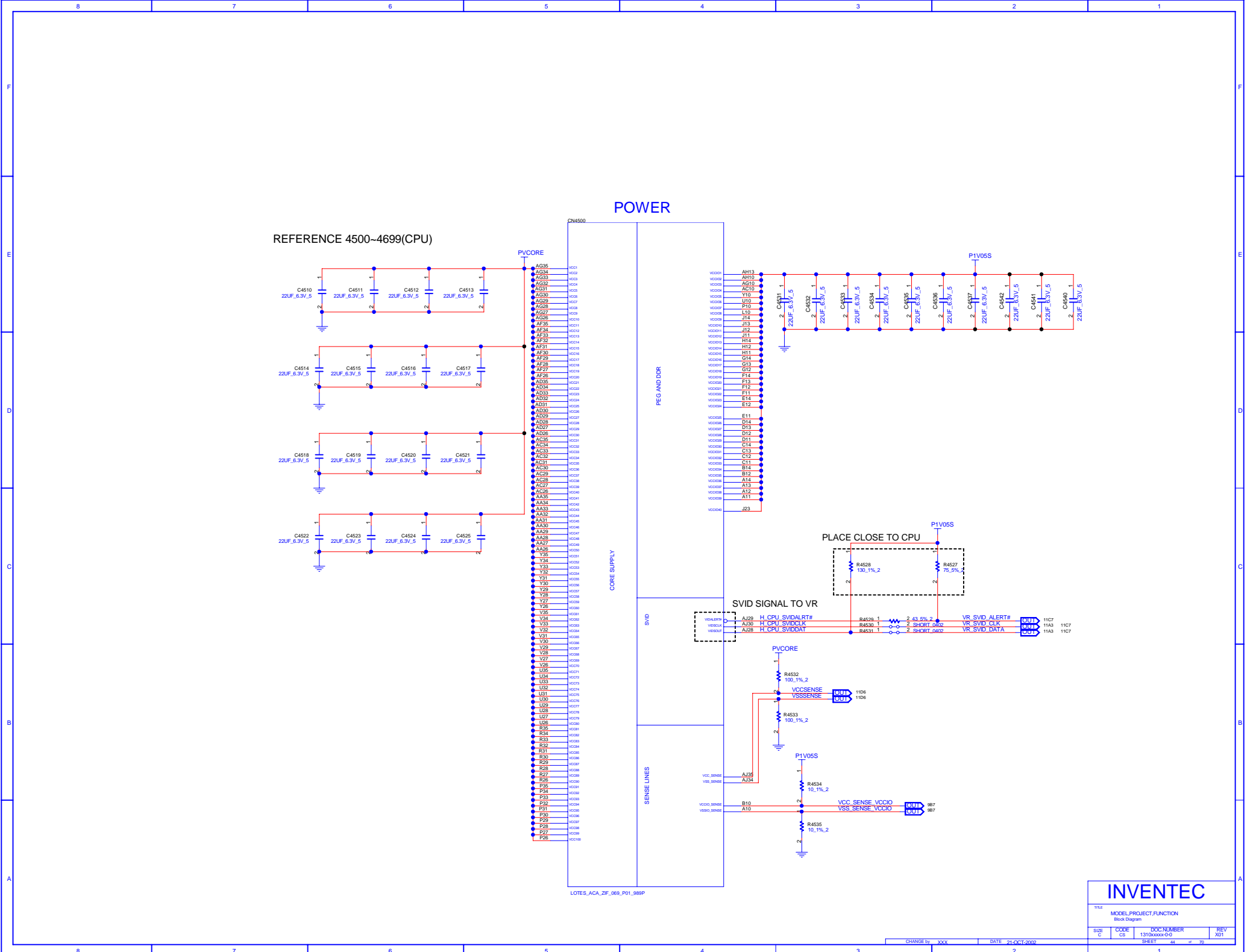

REFERENCE 4500-4699(CPU)

POWER

- CN4500
- PVCORE
- AG35
- AG34
- AG33
- AG32
- AG31
- AG30
- AG29
- AG28
- AG27
- AG26
- AF35
- AF34
- AF33
- AF32
- AF31
- AF30
- AF29
- AF28
- AF27
- AF26
- AD35
- AD34
- AD33
- AD32
- AD31
- AD30
- AD29
- AD28
- AD27
- AD26
- AC35
- AC34
- AC33
- AC32
- AC31
- AC30
- AC29
- AC28
- AC27
- AC26
- AA35
- AA34
- AA33
- AA32
- AA31
- AA30
- AA29
- AA28
- AA27
- AA26
- Y35
- Y34
- Y33
- Y32
- Y31
- Y30
- Y29
- Y28
- Y27
- Y26
- V35
- V34
- V33
- V32
- V31
- V30
- V29
- V28
- V27
- V26
- U35
- U34
- U33
- U32
- U31
- U30
- U29
- U28
- U27
- U26
- R35
- R34
- R33
- R32
- R31
- R30
- R29
- R28
- R27
- R26
- P35
- P34
- P33
- P32
- P31
- P30
- P29
- P28
- P27
- P26

CORE SUPPLY

PEG AND DIR

SVID

SENSE LINES

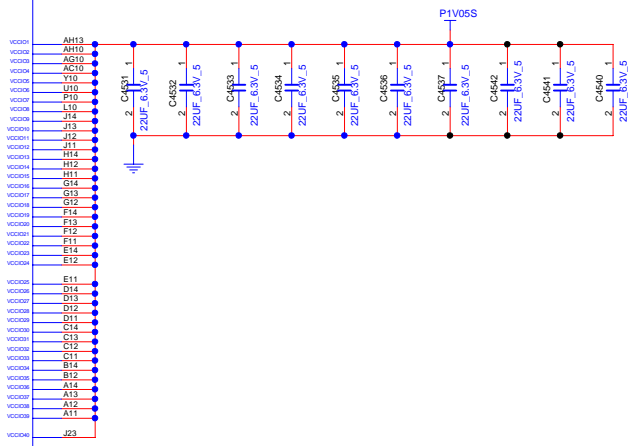

PLACE CLOSE TO CPU

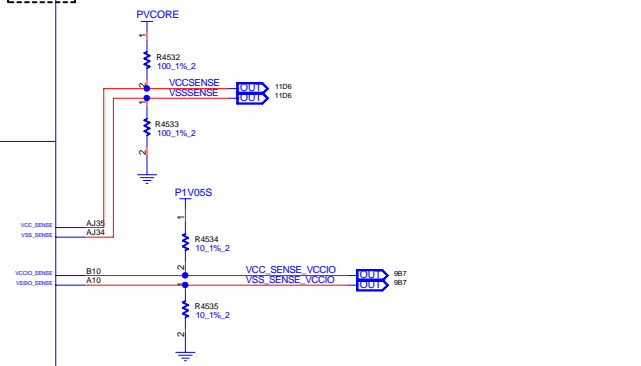

INVENTEC			
TITLE MODEL_PROJECT.FUNCTION Block Diagram			
SIZE C	CODE C3	DOC NUMBER 1310XXXXX-03	REV X01
CHANGE BY XXX		DATE 21-OCT-2002	SHEET 44 of 50

PROCESSOR DRIVEN VREF PATH WAS STUFFED BY DEFAULT:
ROUTE WITH MIN. TRACE WIDTH OF 10 MILS

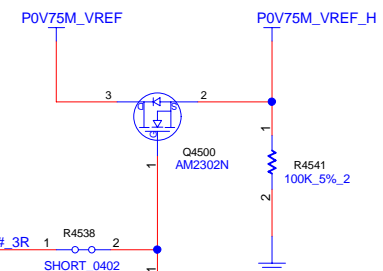
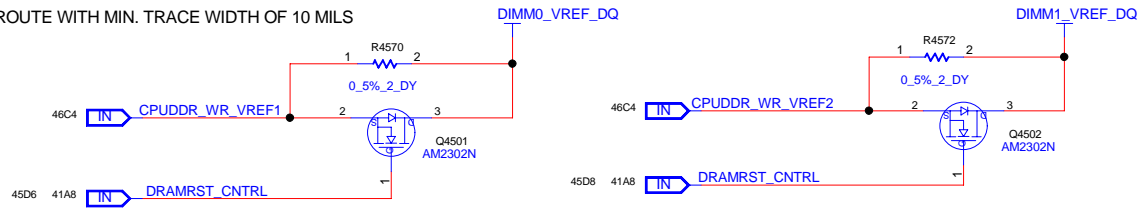

POWER

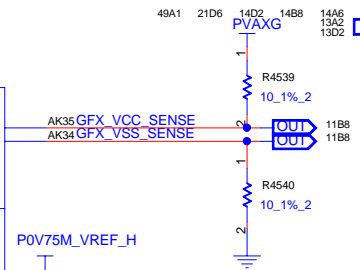
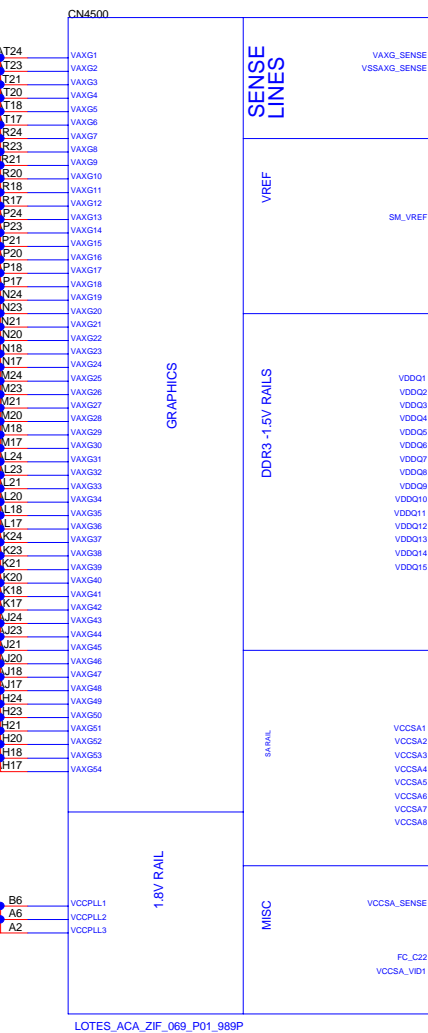
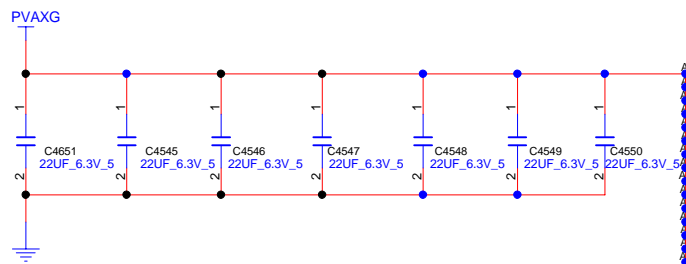

NOTE : DDR_WR_VREF SHOULD HAVE 20/20 MIL WHEREVER POSSIBLE

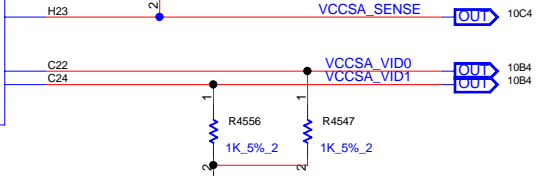
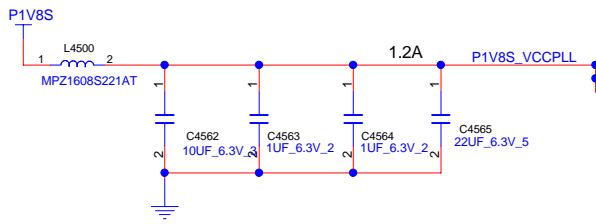
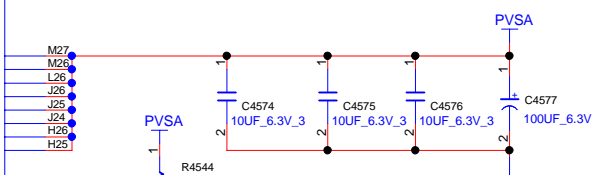
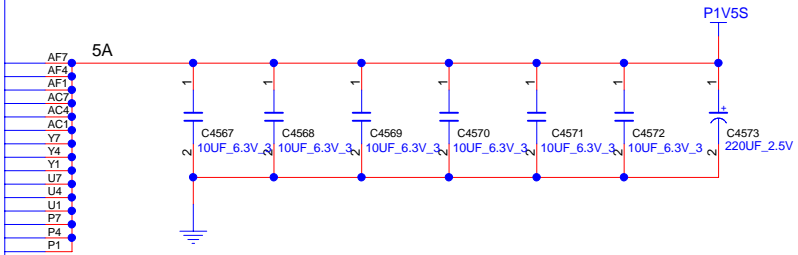

INVENTEC

TITLE			
MODEL PROJECT FUNCTION			
Block Diagram			
SIZE	CODE	DOC NUMBER	REV
A3	CS	1310xxxx-0-0	X01

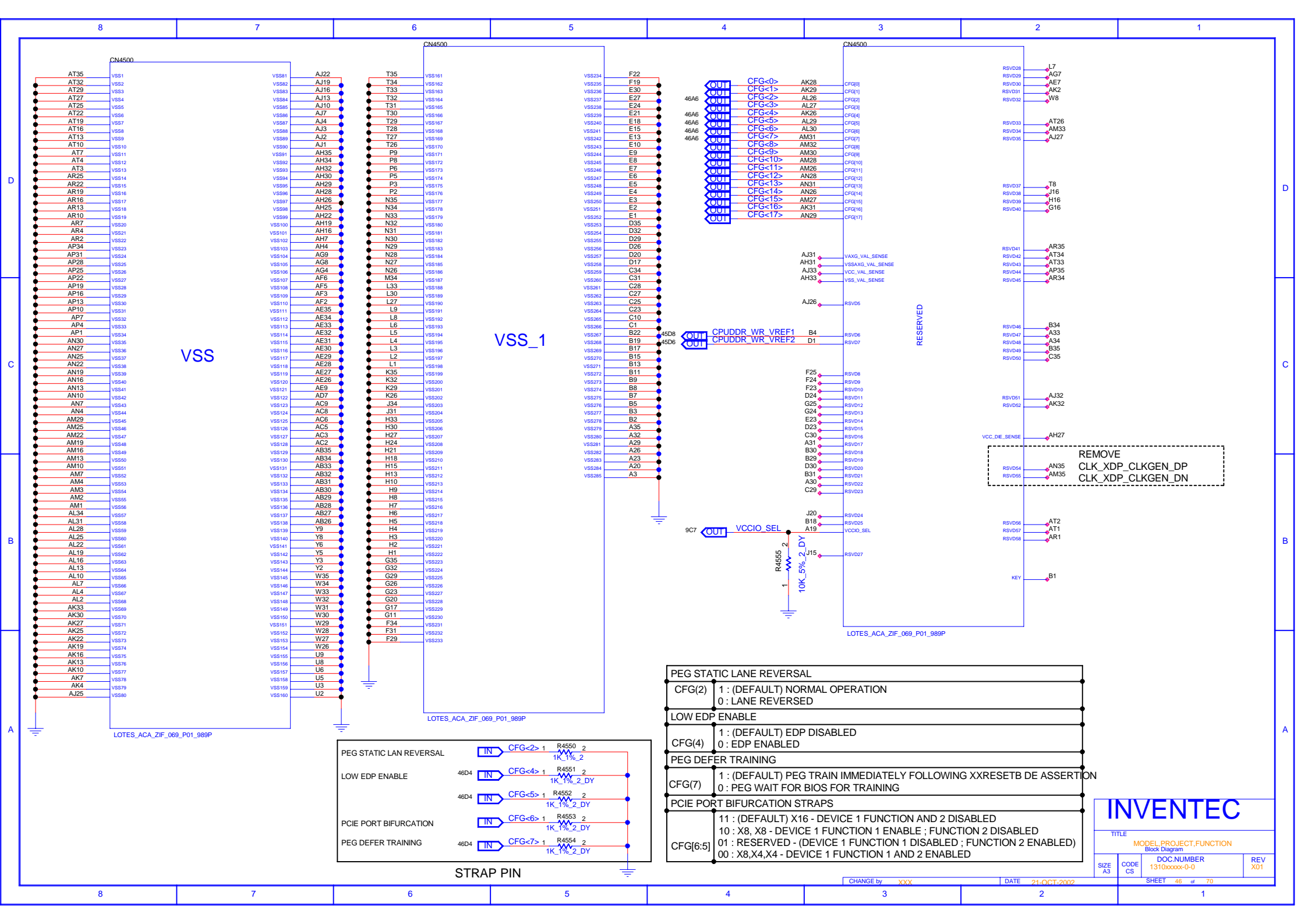

VSS

VSS_1

RESERVED

VCCIO_SEL

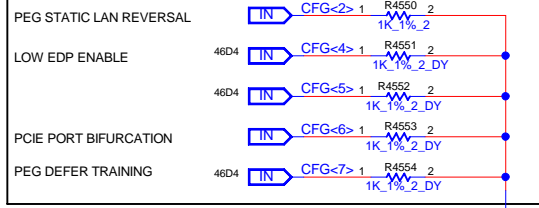

STRAP PIN

PEG STATIC LANE REVERSAL	
CFG(2)	1 : (DEFAULT) NORMAL OPERATION 0 : LANE REVERSED
LOW EDP ENABLE	
CFG(4)	1 : (DEFAULT) EDP DISABLED 0 : EDP ENABLED
PEG DEFER TRAINING	
CFG(7)	1 : (DEFAULT) PEG TRAIN IMMEDIATELY FOLLOWING XXRESETB DE ASSERTION 0 : PEG WAIT FOR BIOS FOR TRAINING
PCIE PORT BIFURCATION STRAPS	
CFG[6:5]	11 : (DEFAULT) X16 - DEVICE 1 FUNCTION AND 2 DISABLED 10 : X8, X8 - DEVICE 1 FUNCTION 1 ENABLE ; FUNCTION 2 DISABLED 01 : RESERVED - (DEVICE 1 FUNCTION 1 DISABLED ; FUNCTION 2 ENABLED) 00 : X8,X4,X4 - DEVICE 1 FUNCTION 1 AND 2 ENABLED

REMOVE
CLK_XDP_CLKGEN_DP
CLK_XDP_CLKGEN_DN

INVENTEC

TITLE
MODEL:PROJECT:FUNCTION
Block Diagram

SIZE A3	CODE CS	DOC NUMBER 1310xxxx-0-0	REV X01
------------	------------	----------------------------	------------

CHANGE by XXX DATE 21-OCT-2002 SHEET 46 of 70

REFERENCE 4700~4949(PCH)

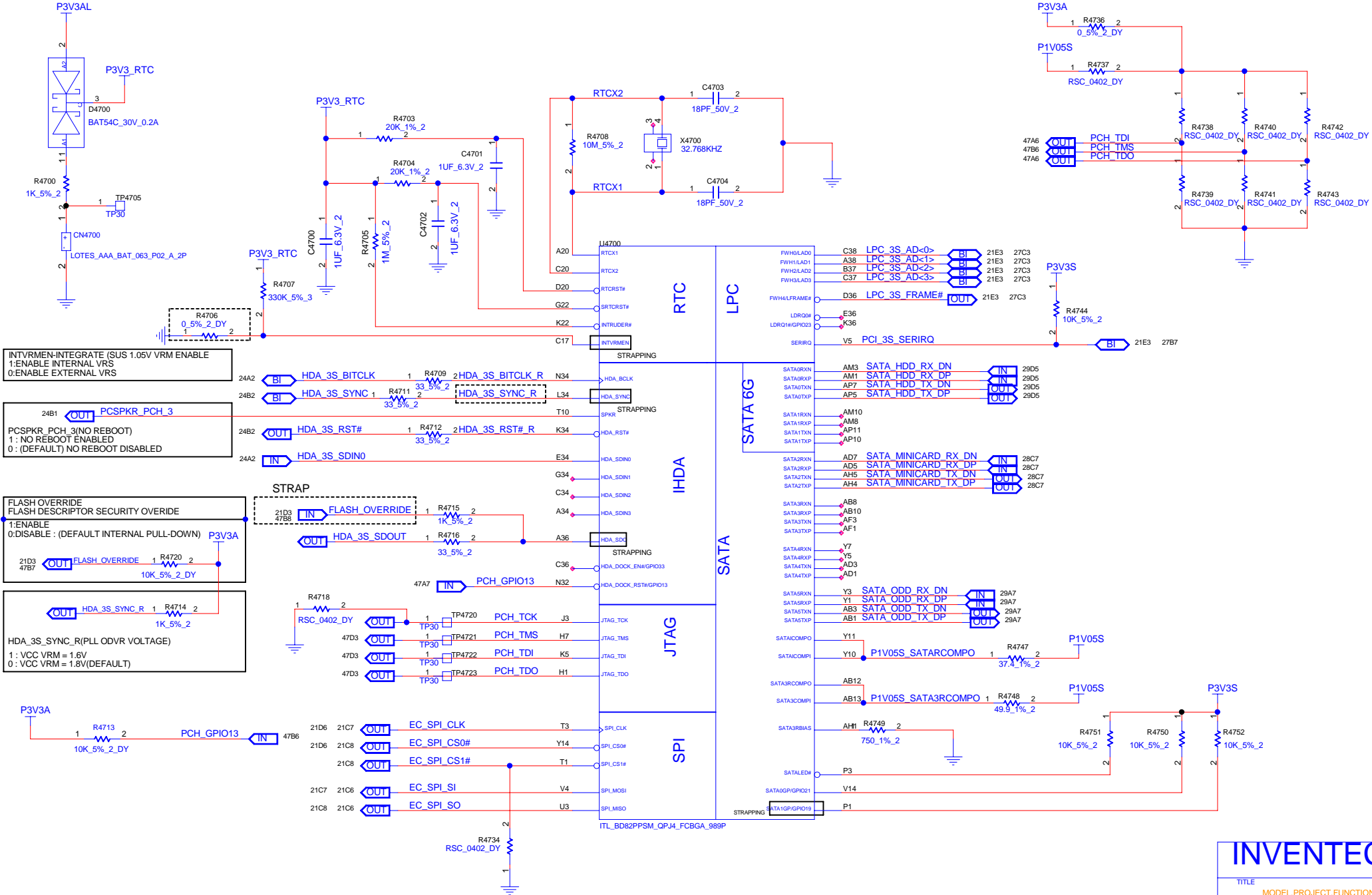

INTVRMEN-INTEGRATE (SUS 1.05V VRM ENABLE)
 1:ENABLE INTERNAL VRS
 0:ENABLE EXTERNAL VRS

PCSPKR_PCH_3
 1: NO REBOOT ENABLED
 0: (DEFAULT) NO REBOOT DISABLED

FLASH OVERRIDE
 FLASH DESCRIPTOR SECURITY OVERRIDE
 1:ENABLE
 0:DISABLE : (DEFAULT INTERNAL PULL-DOWN)

HDA_3S_SYNC_R(PLL ODVR VOLTAGE)
 1: VCC VRM = 1.6V
 0: VCC VRM = 1.8V(DEFAULT)

INVENTEC			
TITLE			
MODEL PROJECT FUNCTION			
Block Diagram			
SIZE	CODE	DOC NUMBER	REV
A3	CS	1310xxxx-0-0	X01
CHANGE by XXX			DATE 21-OCT-2002
SHEET 47 of 70			

REFERENCE 4700~4949(PCH)

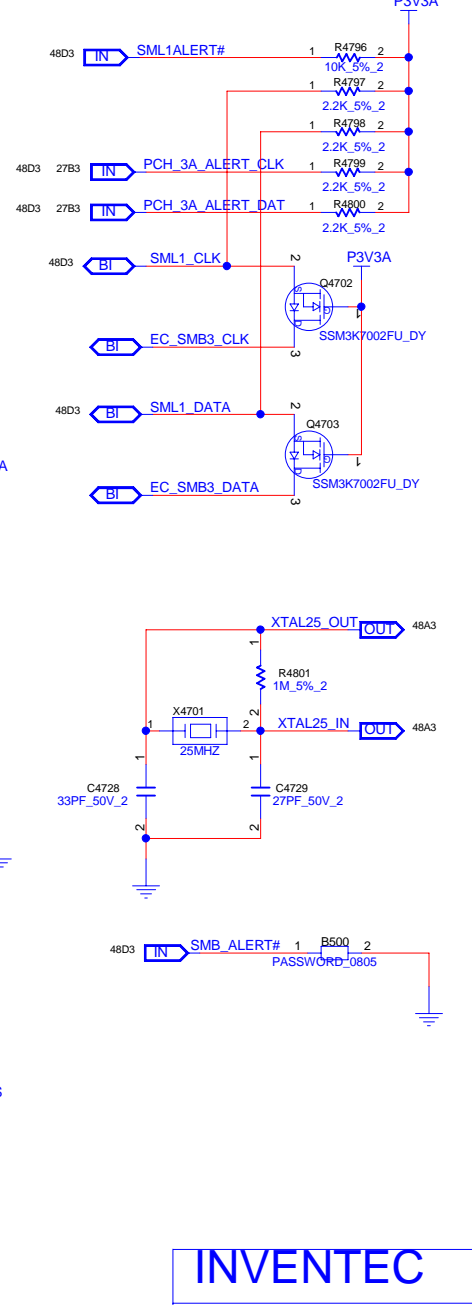
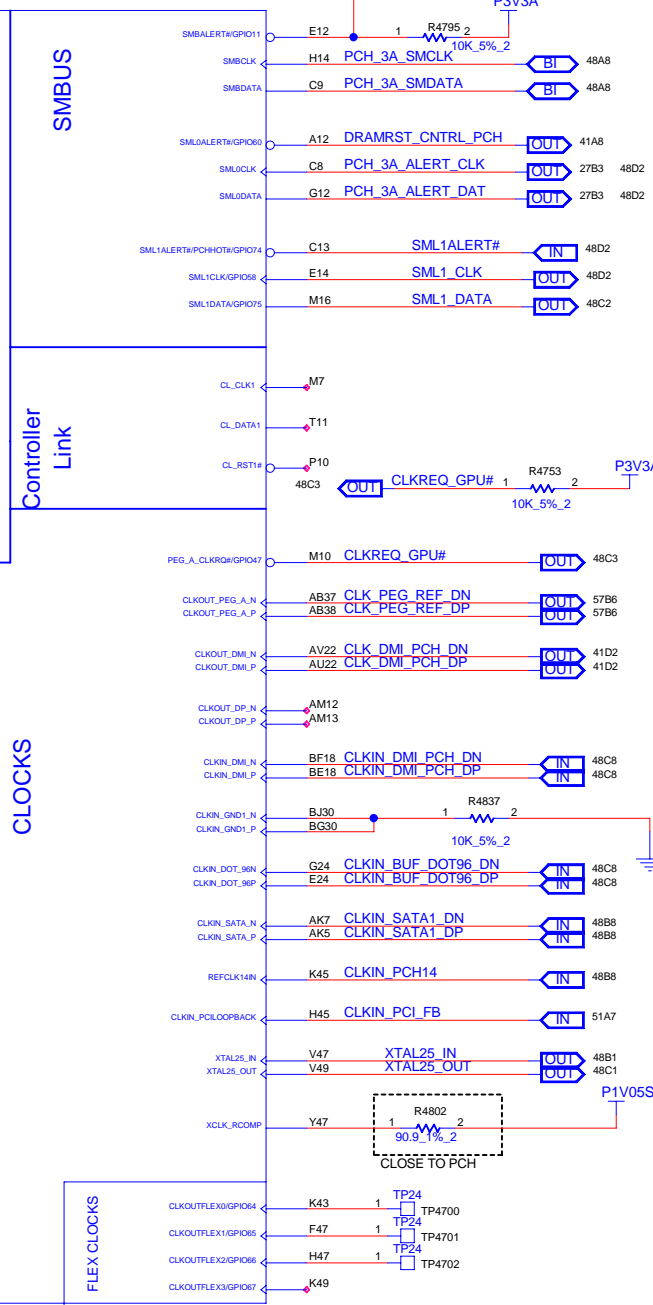
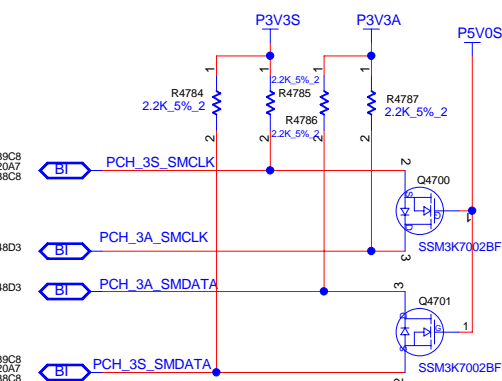
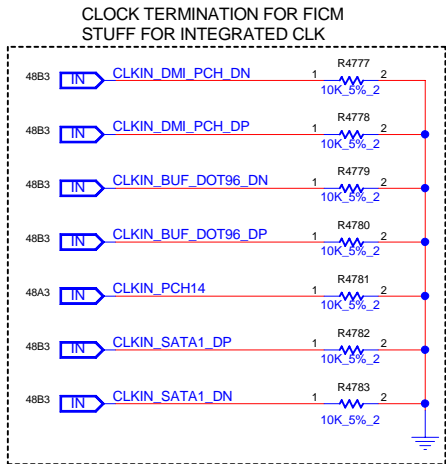
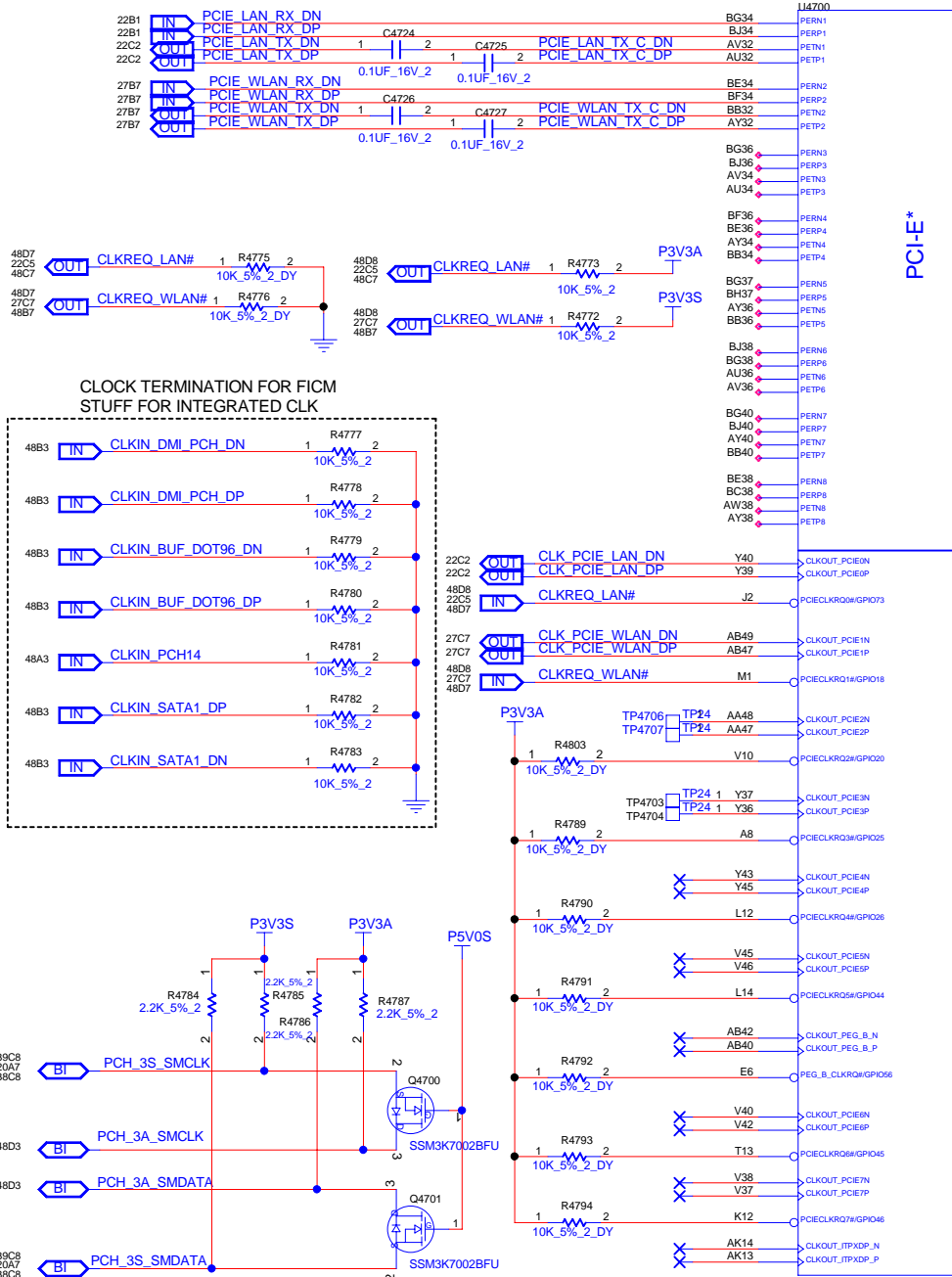

ITL_BD82PPSM_OPJ4_FCBGA_989P

INVENTEC			
TITLE			
MODEL PROJECT FUNCTION			
Block Diagram			
DOC NUMBER			
1310xxxx-0-0			
SIZE	CODE	REV	CS
A3		X01	

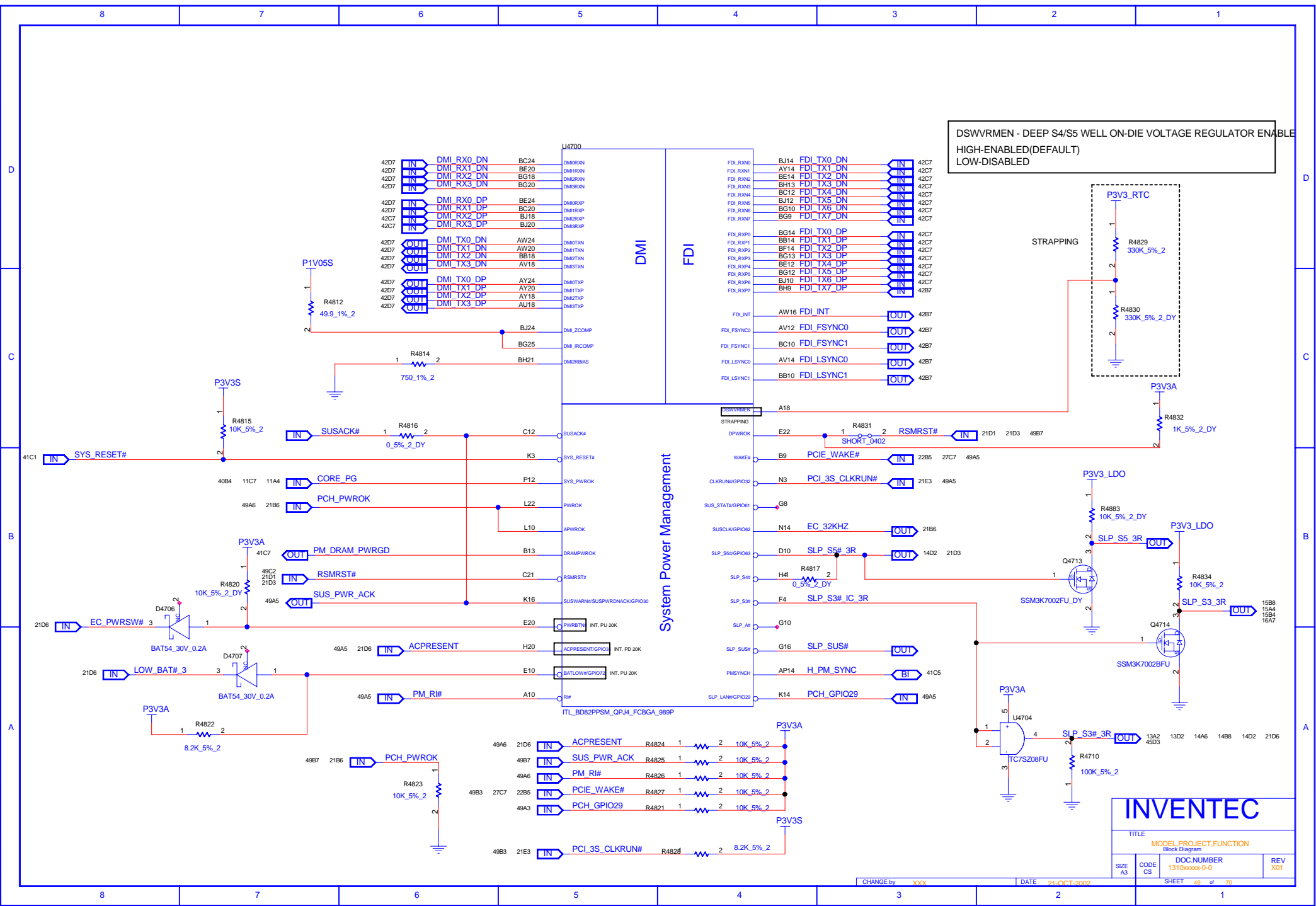

DSWVRMEN - DEEP S4/S5 WELL ON-DIE VOLTAGE REGULATOR ENABLE
HIGH-ENABLED(DEFAULT)
LOW-DISABLED

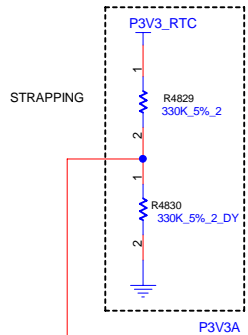

INVENTEC			
TITLE			
MODEL PROJECT.FUNCTION			
Block Diagram			
SIZE	CODE	DOC NUMBER	REV
A3	CS	1310xxxx-U-0	X01
CHANGE by XXX		DATE 21-OCT-2002	
SHEET 49		of 70	

System Power Management

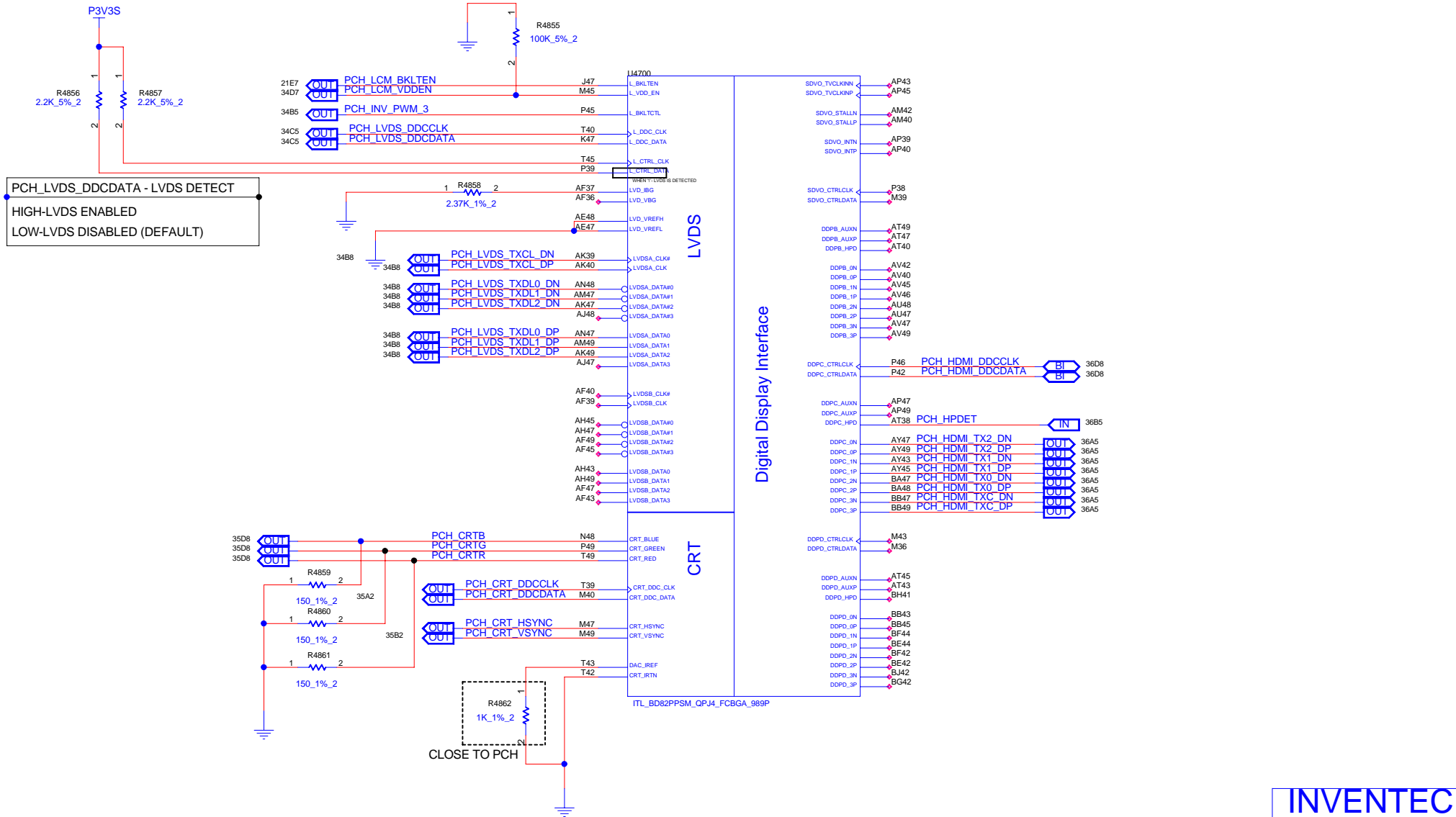

PCH_LVDS_DDCDATA - LVDS DETECT
 HIGH-LVDS ENABLED
 LOW-LVDS DISABLED (DEFAULT)

CLOSE TO PCH

INVENTEC			
TITLE			
MODEL PROJECT FUNCTION Block Diagram			
DOC NUMBER 1310xxxxx-0-0			REV X01
SIZE A3	CODE CS		
SHEET 50 of 70			

GPIO51 BBS_BIT1	GPIO19 BBS_BIT0	BOOT BIOS DESTINATION
0	1	RESERVED(NAND)
1	0	-----
1	1	SPI (DEFAULT)
0	0	LPC

P3V3S

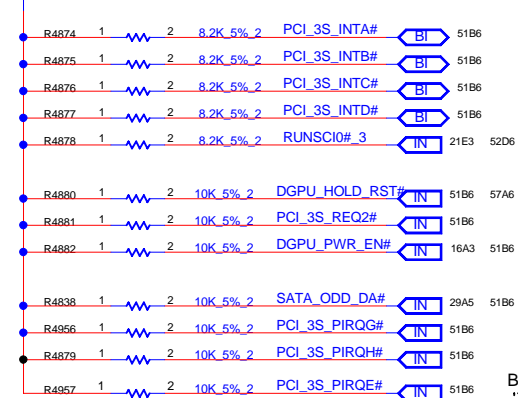

ROUTE WITH 90 OHMS IMPEDANCE
TOTAL LENGTH NO LONGER THAN 11 INCHES

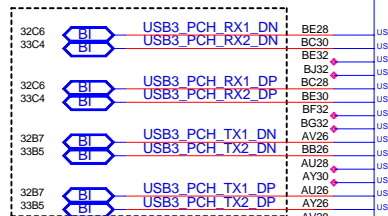

BBS STRAPING

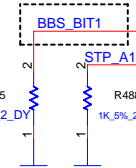

LOW=A16 SWAP OVERRIDE
STP_A160VR
TOP-BLOCK SWAP OVERRIDE
HIGH=DEFAULT

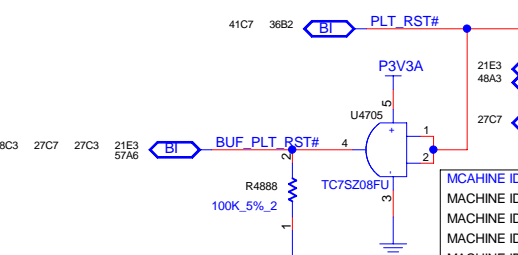

MACHINE ID 0: USB ID0
MACHINE ID 1: POWER EXPRESS (YES:1 NO:0)
MACHINE ID 2: UMA:1 / DIS:0
MACHINE ID 3: MAINSTREAM:1 / ENTRY:0
MACHINE ID 4: HDMI:1 / NO HDMI:0
MACHINE ID 5: SLEEP&CHARGE&DOLBY:(YES1 / NO 0)
MACHINE ID 6: USB ID1
MACHINE ID 1_DB : 35W CPU ONLY :1 / 35W&45W CPU:0

USB ID0	USB ID1	USB3.0 X2 / 2.0 X1	USB3.0 X1 / 2.0 X2	USB2.0 X3
1	1	1	1	0
1	0	1	1	1

NOTE:10K_5%(60130B1030ZT)

U4700

BG26 TP1
BJ26 TP2
BH25 TP3
BJ16 TP4
BG16 TP5
AH38 TP6
AH37 TP7
AK43 TP8
AK45 TP9
C18 TP10
N30 TP11
H3 TP12
AH12 TP13
AM4 TP14
AM5 TP15
Y13 TP16
K24 TP17
L24 TP18
AB46 TP19
AB45 TP20

B21 TP21
M20 TP22
AY16 TP23
BG46 TP24

BE28 USB3RN1
BC30 USB3RN2
BE32 USB3RN3
BJ32 USB3RN4
BC28 USB3RP1
BE30 USB3RP2
BF33 USB3RP3
BG32 USB3RP4
AV26 USB3TN1
B826 USB3TN2
AU28 USB3TN3
AY30 USB3TN4
AU26 USB3TP1
AY26 USB3TP2
AV28 USB3TP3
AW30 USB3TP4

K40 PIRQA#
K38 PIRQB#
H38 PIRC#
G38 PIRQD#
C46 RECI#EPD050
C44 RECI#EPD052
E40 REQ03#GPD04
D47 GNT1#GPIO51
E42 GNT2#GPIO53
F46 GNT3#GPIO55
G42 PIRQE#GPIO2
G40 PIRQF#GPIO3
C42 PIRQG#GPIO4
D44 PIRQH#GPIO5
K10 INT_PU 20K
C6 PLTRST#
H49 CLKOUT_PC1
H43 CLKOUT_PC1
J48 CLKOUT_PC2
K42 CLKOUT_PC3
H40 CLKOUT_PC4

RSVD

NVRAM

DEBUG PORT

PCI

USB

USB

RSVD1 AY7
RSVD2 AV7
RSVD3 AU3
RSVD4 BG4
RSVD5 AT10
RSVD6 BC8
RSVD7 AU2
RSVD8 AT4
RSVD9 AT3
RSVD10 AT1
RSVD11 AY3
RSVD12 AT5
RSVD13 AV3
RSVD14 AV1
RSVD15 BB1
RSVD16 BA3
RSVD17 BB5
RSVD18 BB3
RSVD19 BB7
RSVD20 BE8
RSVD21 BD4
RSVD22 BF6
RSVD23 AV5
RSVD24 AV10
RSVD25 AT8
RSVD26 AY5
RSVD27 BA2
RSVD28 AT12
RSVD29 BF3

C24 USB P0 DN
A24 USB P0 DP
C25 USB P1 DN
B25 USB P1 DP
C26 USB P2 DN
A26 USB P2 DP
K28 H28
E28 D28
C28 D28
A28 C28
C29 B29
N28 M28
L30 M28
K30 L30
G30 USB CR DN
E30 USB CR DP
C30 USB WLAN DN
A30 USB WLAN DP
L32 USB CAM DN
K32 USB CAM DP
G32 USB 3G DN
E32 USB 3G DP
C32 C32
C32 C32
A32 A32

C33 R4835
B33 22.6_1%_3
CLOSE TO PCH

A14 MACHINE ID0
K20 MACHINE ID1
B17 MACHINE ID2
C2#GPD04 C16 MACHINE ID3
C4#GPD03 L16 MACHINE ID4
D0#GPD08 A16 MACHINE ID5
C0#GPD10 D14 MACHINE ID6
C7#GPD14 C14 MACHINE ID1_DB

A14 MACHINE ID0 R4900 1 2 10K_5%_2_DY
A14 MACHINE ID1 R4901 1 2 10K_5%_2_DY
A14 MACHINE ID2 R4902 1 2 10K_5%_2_DY
A14 MACHINE ID3 R4903 1 2 10K_5%_2_DY
A14 MACHINE ID4 R4904 1 2 10K_5%_2_DY
A14 MACHINE ID5 R4905 1 2 10K_5%_2_DY
A14 MACHINE ID6 R4906 1 2 10K_5%_2_DY
A14 MACHINE ID1_DB R4907 1 2 10K_5%_2_DY

NOTE:
USB2.0/3.0 COMBO-USB2.0 PORT 0,1 MAPPED USB3.0 PORT 1,2

P0.P1 RESERVER FOR USB3.0

CARD READER
WLAN
WEBCAM
3G

INVENTEC

TITLE	MODEL_PROJECT.FUNCTION	REV	X01
SIZE	A3	DOC.NUMBER	1310xxxx-0-0
CODE	CS	SHEET	51 of 70

CHANGE by XXX DATE 21-OCT-2002

NOTE:10K_5%(60130B1030ZT)

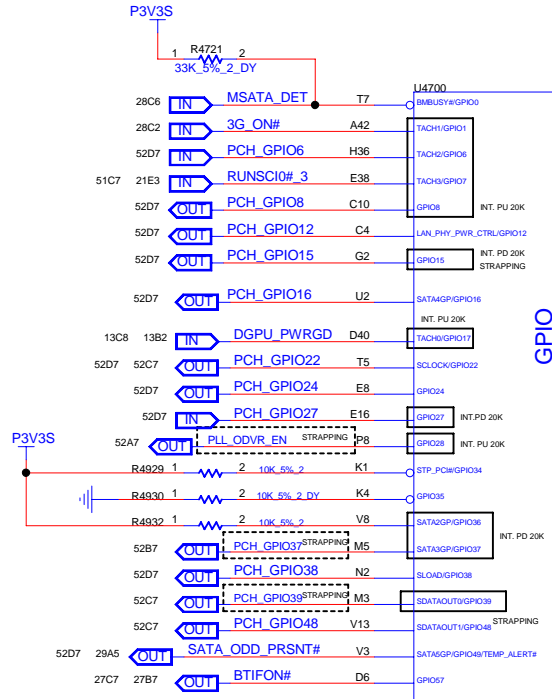
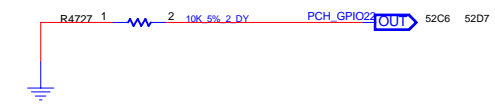
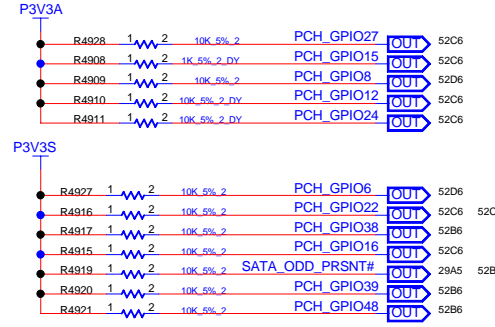

GPIO

NCTF

CPU/MISC

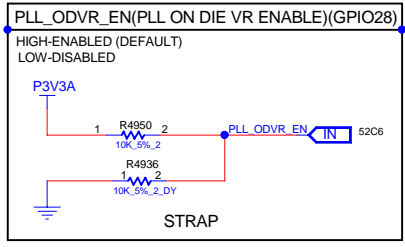
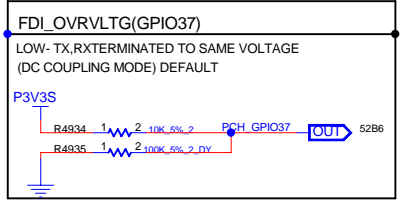
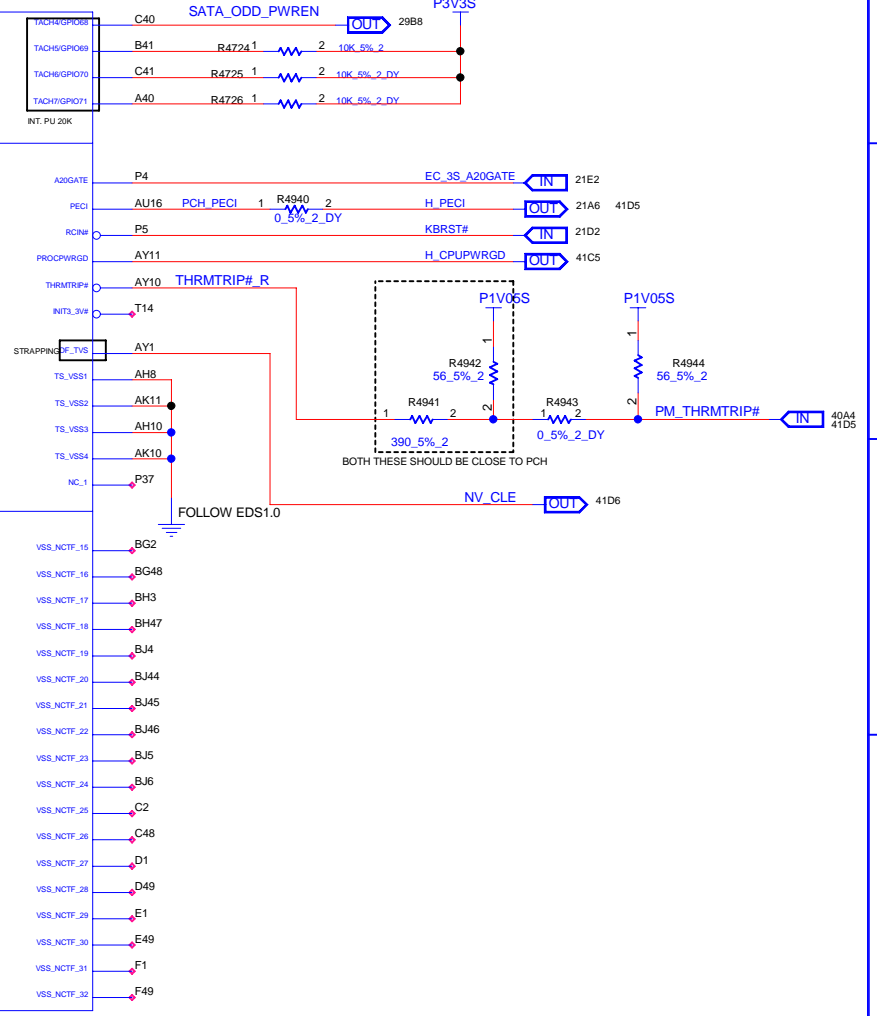

INVENTEC

TITLE			
MODEL PROJECT.FUNCTION			
Block Diagram			
SIZE	CODE	DOC NUMBER	REV
A3	CS	1310xxxx-0-0	X01

REFERENCE 4700~4949(PCH)

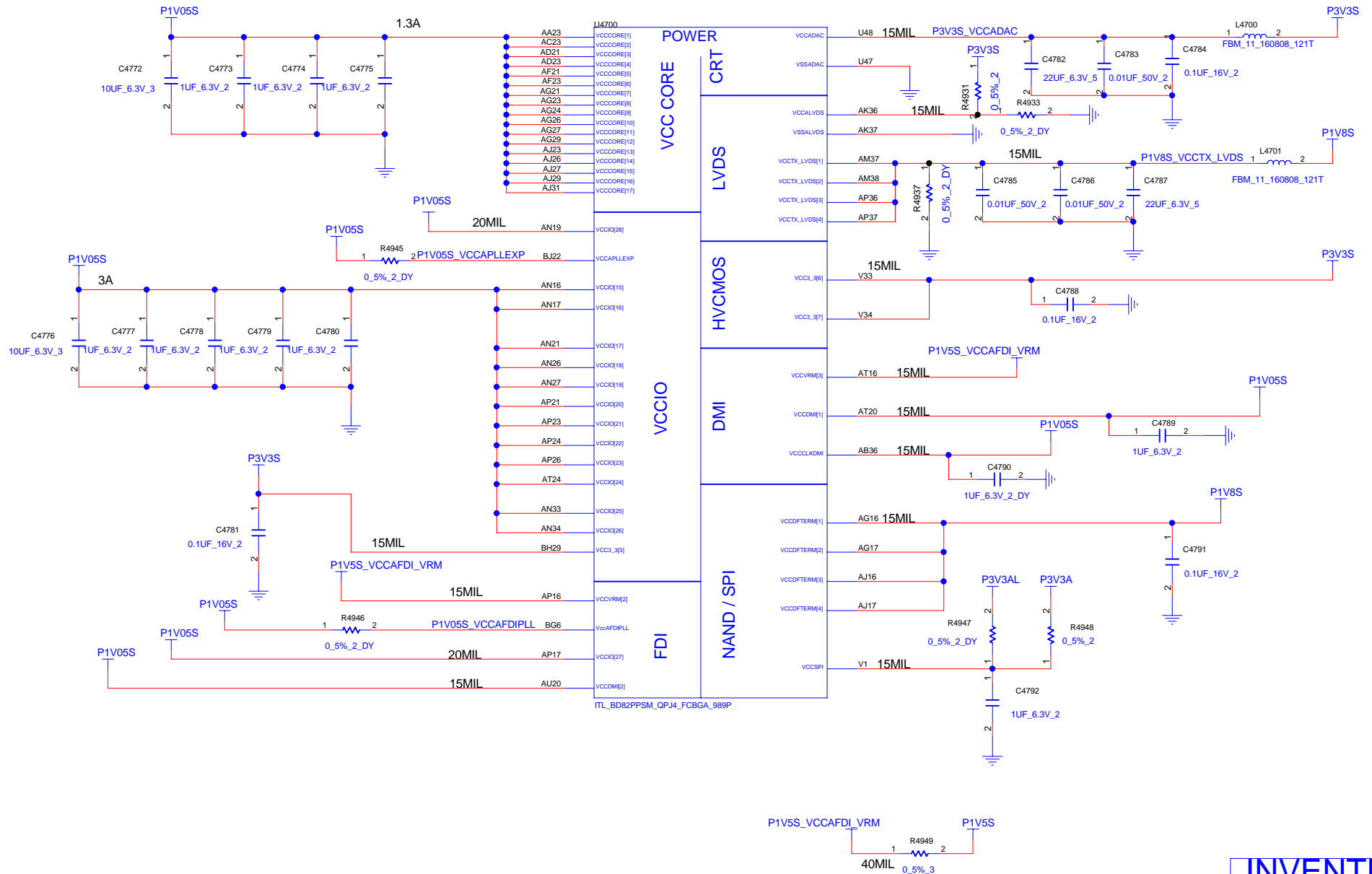

INVENTEC

TITLE			
MODEL PROJECT FUNCTION			
Block Diagram			
SIZE	CODE	DOC NUMBER	REV
A3	CS	1310xxxx-0-0	X01

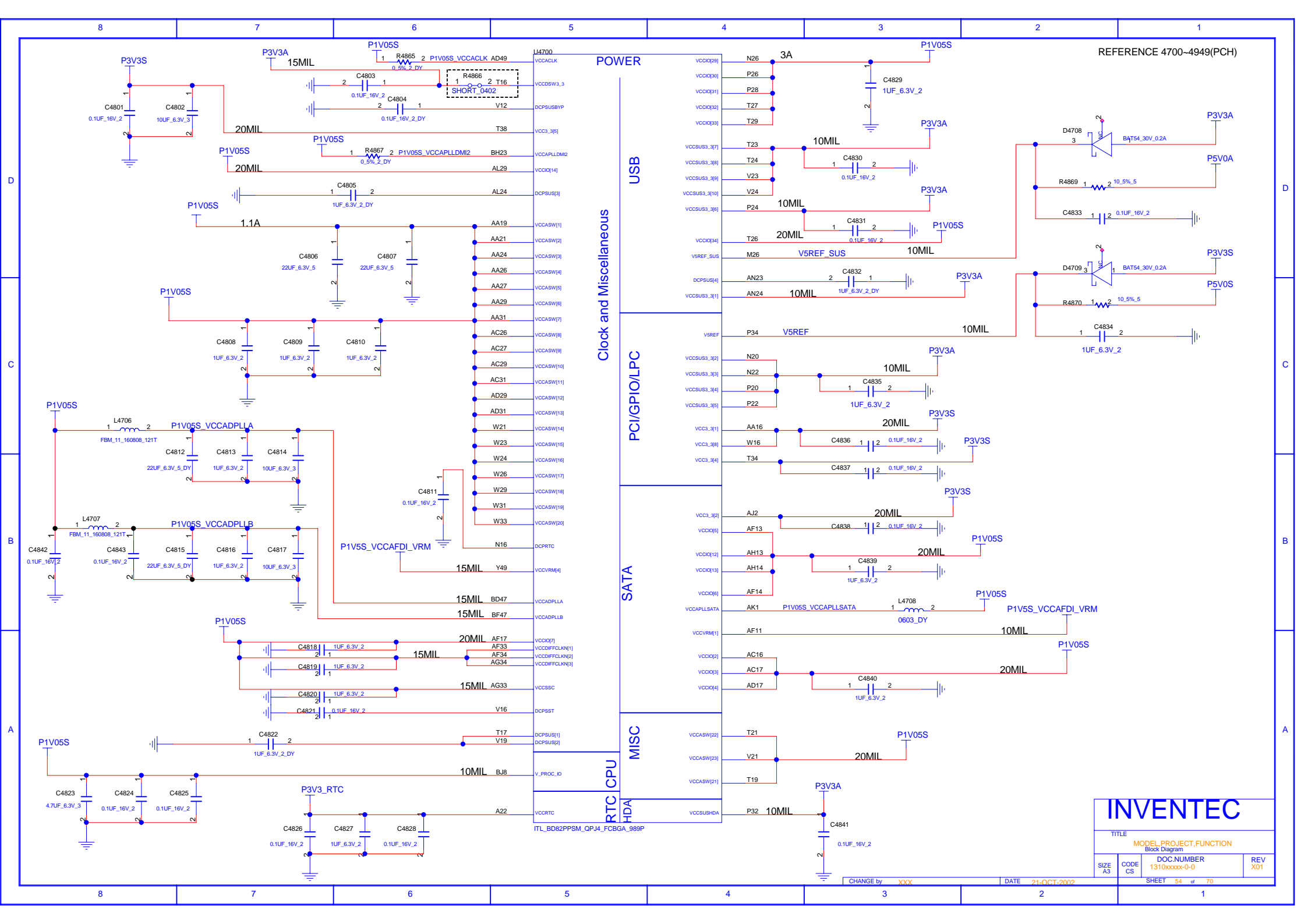

REFERENCE 4700-4949(PCH)

POWER

USB

Clock and Miscellaneous

PCI/GPIO/LPC

SATA

MISC

RTC CPU

HDA

INVENTEC

TITLE			
MODEL PROJECT FUNCTION			
Block Diagram			
DOC NUMBER			
1310xxxx-0-0			
SIZE	CODE	REV	
A3	CS	X01	

REFERENCE 4700-4949(PCH)

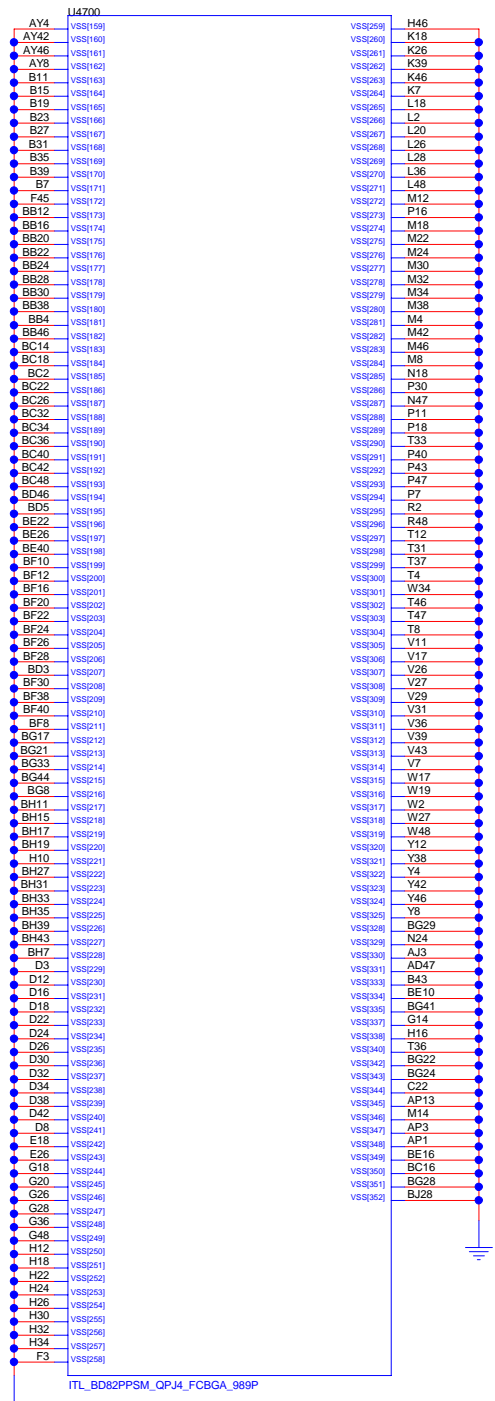
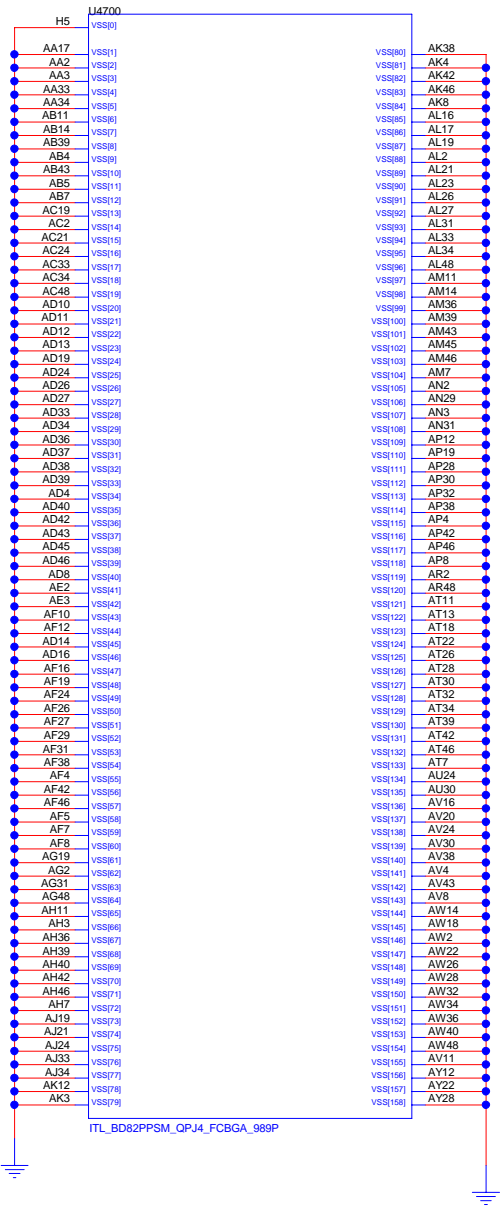

INVENTEC

TITLE MODEL PROJECT FUNCTION
Block Diagram

SIZE A3	CODE CS	DOC NUMBER 1310xxxx-0-0	REV X01
---------	---------	-------------------------	---------

CHANGE by XXX DATE 21-OCT-2002 SHEET 55 of 70

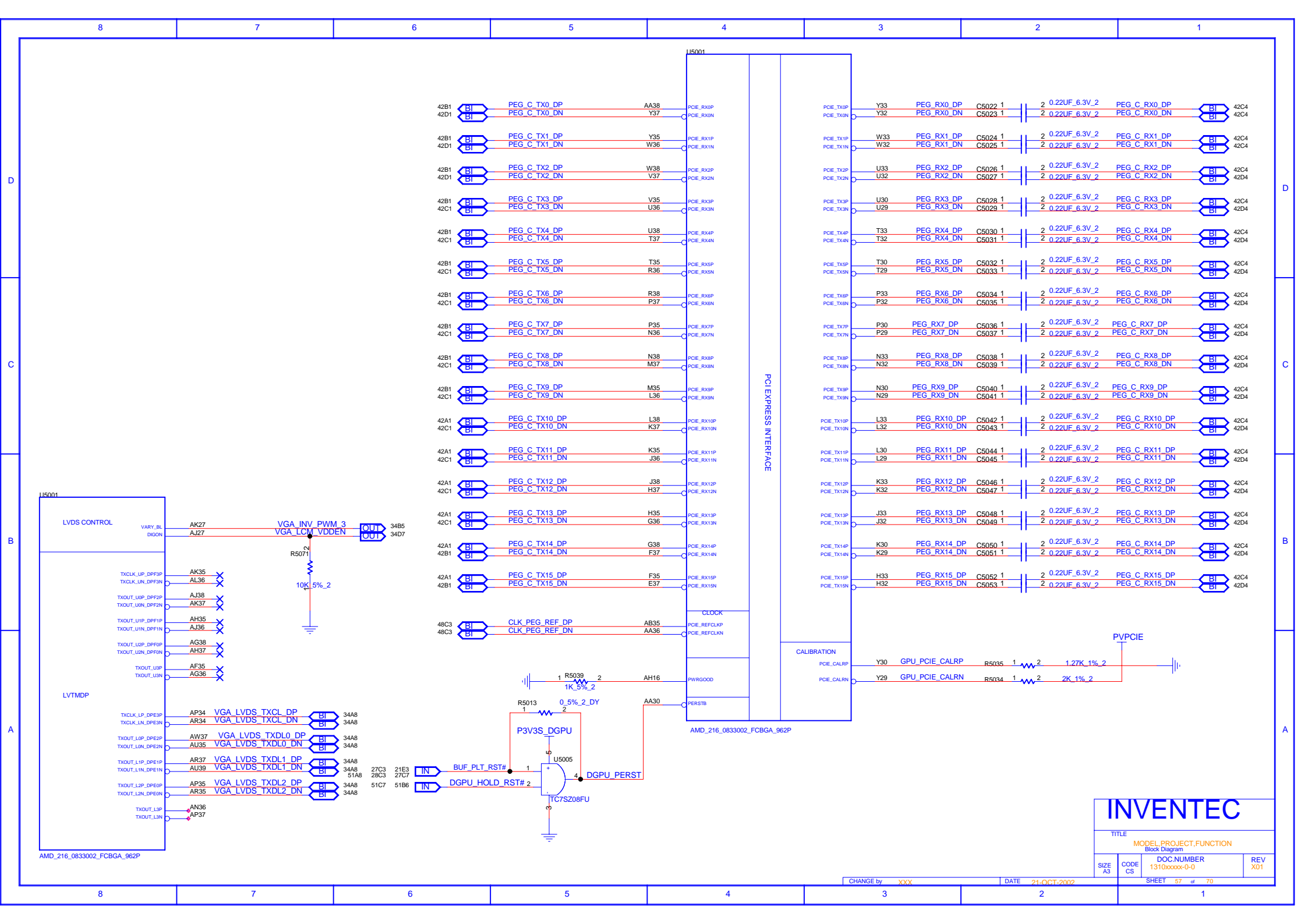

INVENTEC			
TITLE			
MODEL PROJECT FUNCTION			
Block Diagram			
SIZE	CODE	DOC NUMBER	REV
A3	CS	1310xxxx-0-0	X01
CHANGE by XXX			DATE 21-OCT-2002
SHEET 57 of 70			

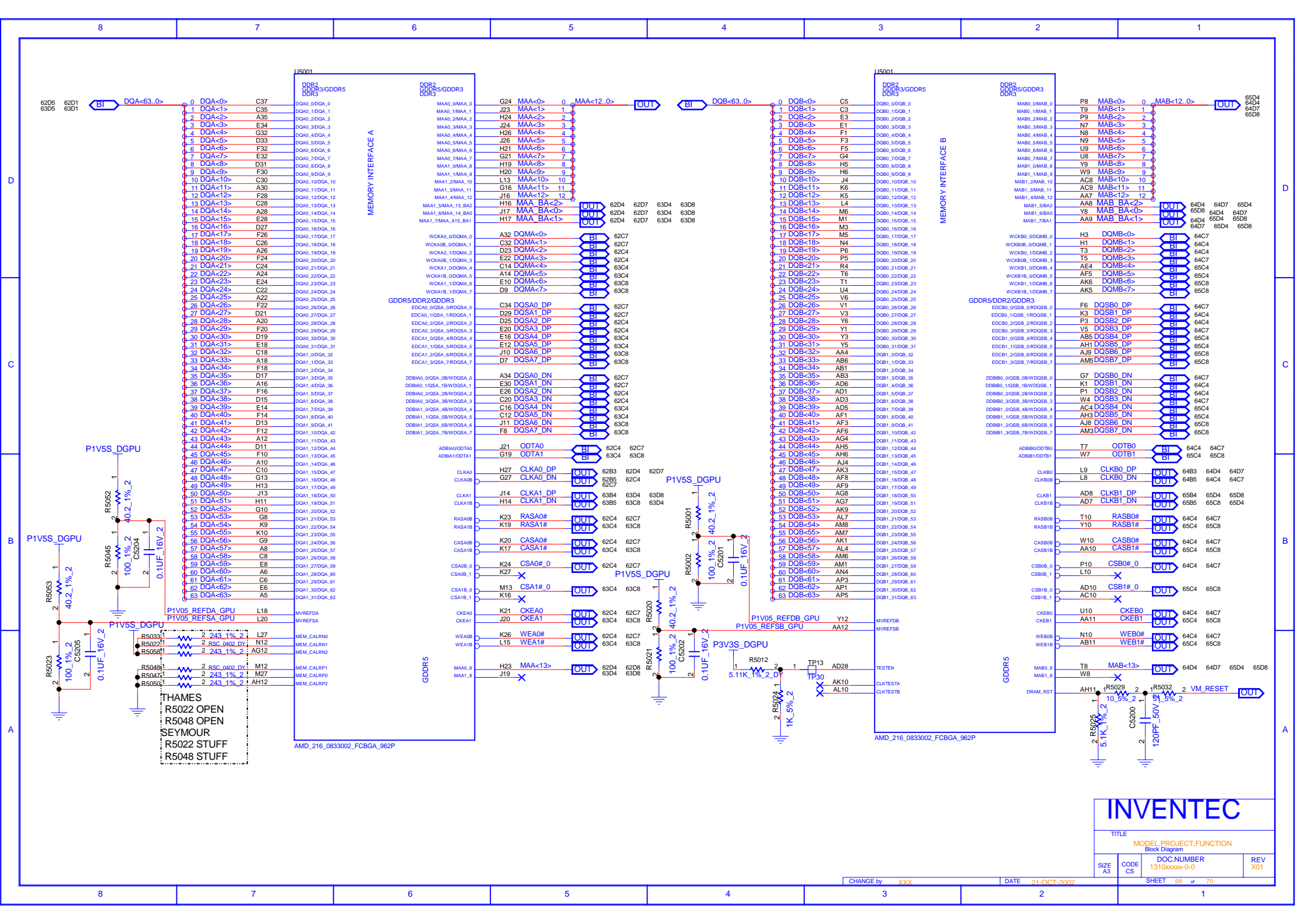

THAMES
R5022 OPEN
R5048 OPEN
SEYMOUR
R5022 STUFF
R5048 STUFF

INVENTEC			
TITLE			
MODEL PROJECT FUNCTION			
Block Diagram			
SIZE	CODE	DOC NUMBER	REV
A3	CS	1310xxxx-0-0	X01
CHANGE by		DATE	21-OCT-2002
SHEET		58	of 70

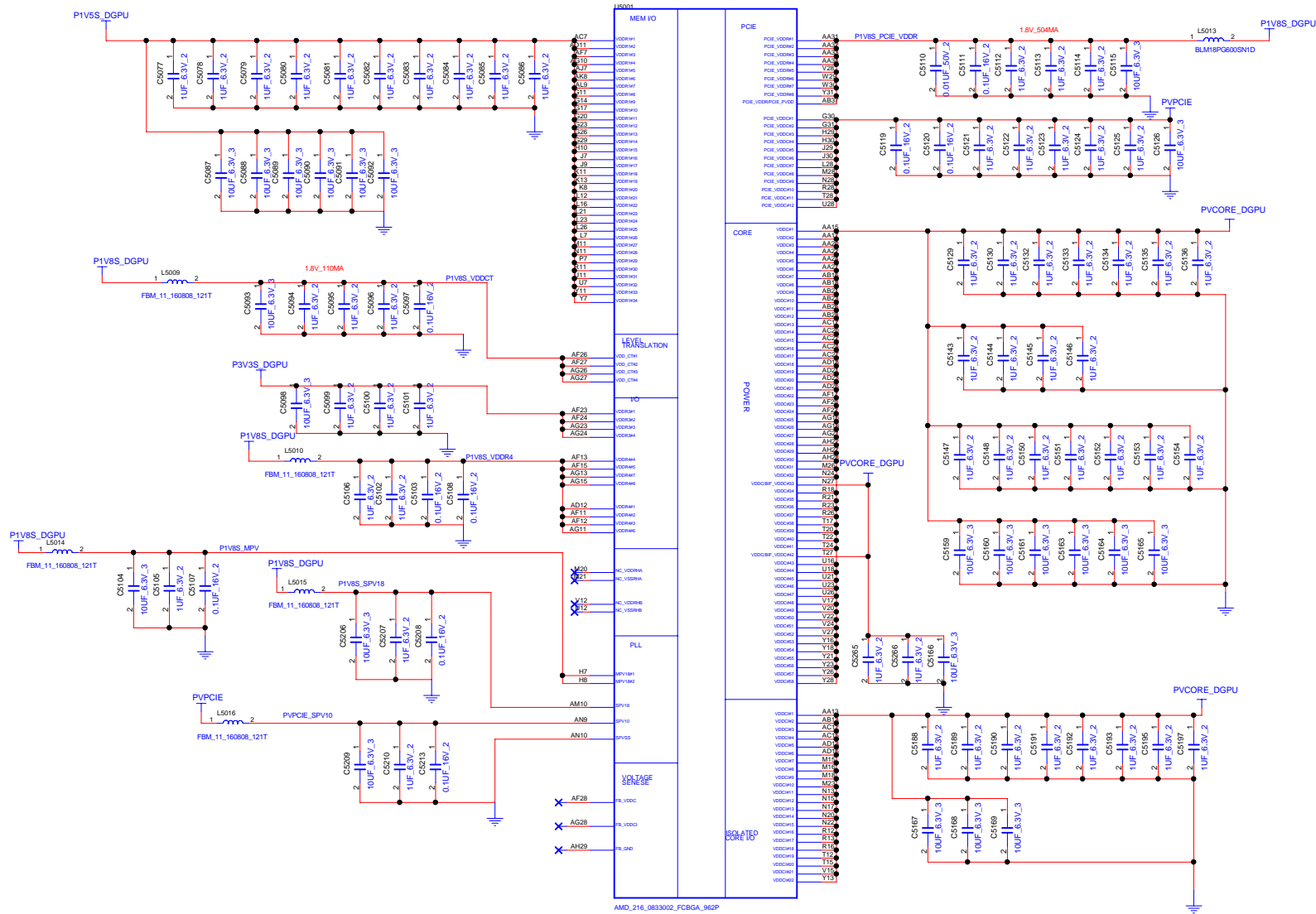

AMD_216_0833002_FCBGA_96P

INVENTEC			
FILE MODEL_PROJECT_FUNCTION Block Diagram			
SIZE C	CODE CS	DOC NUMBER 1310A00000-03	REV X01
SHEET 01		OF 01	

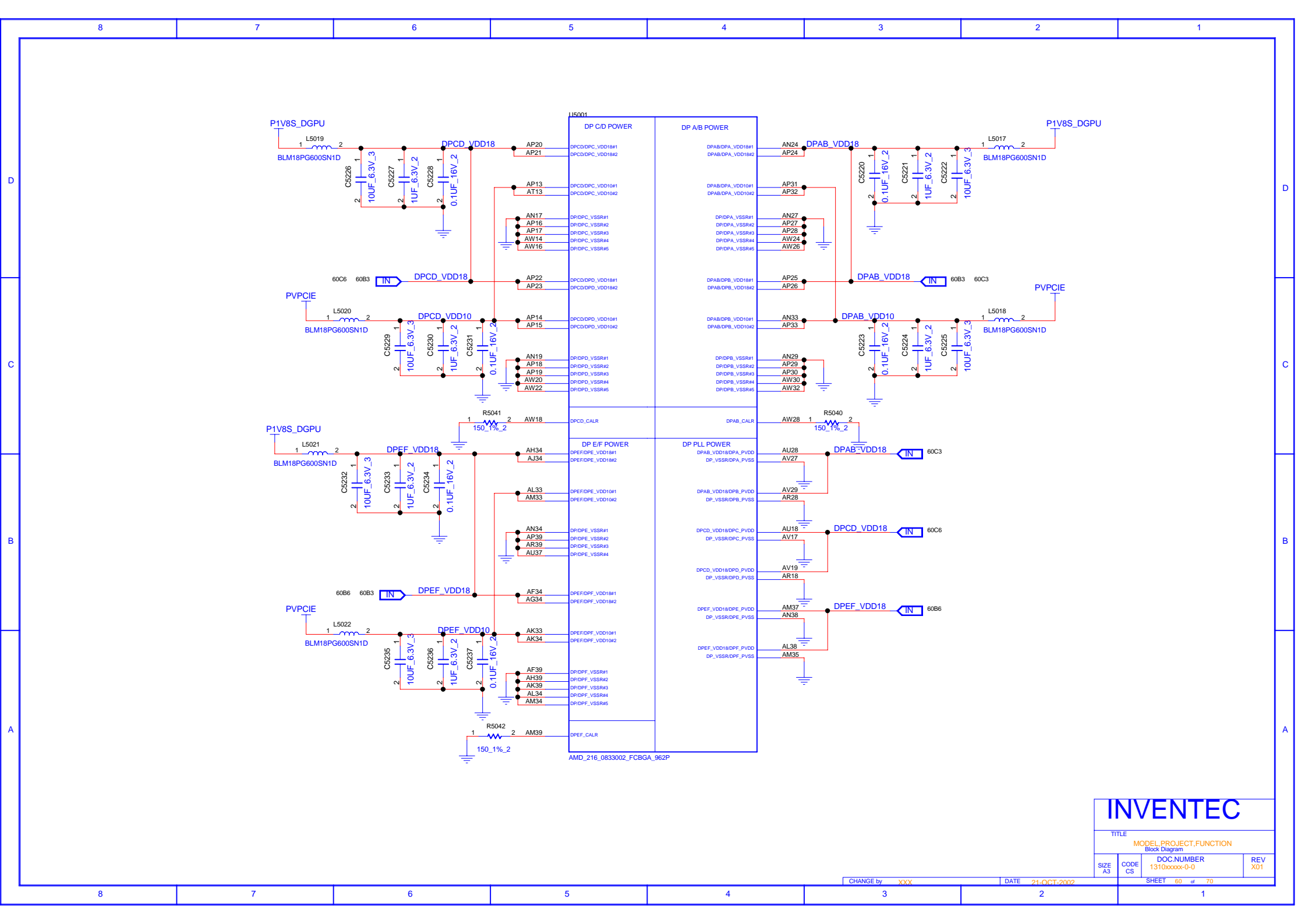

INVENTEC

TITLE			
MODEL PROJECT FUNCTION			
Block Diagram			
SIZE	CODE	DOC NUMBER	REV
A3	CS	1310xxxx-0-0	X01

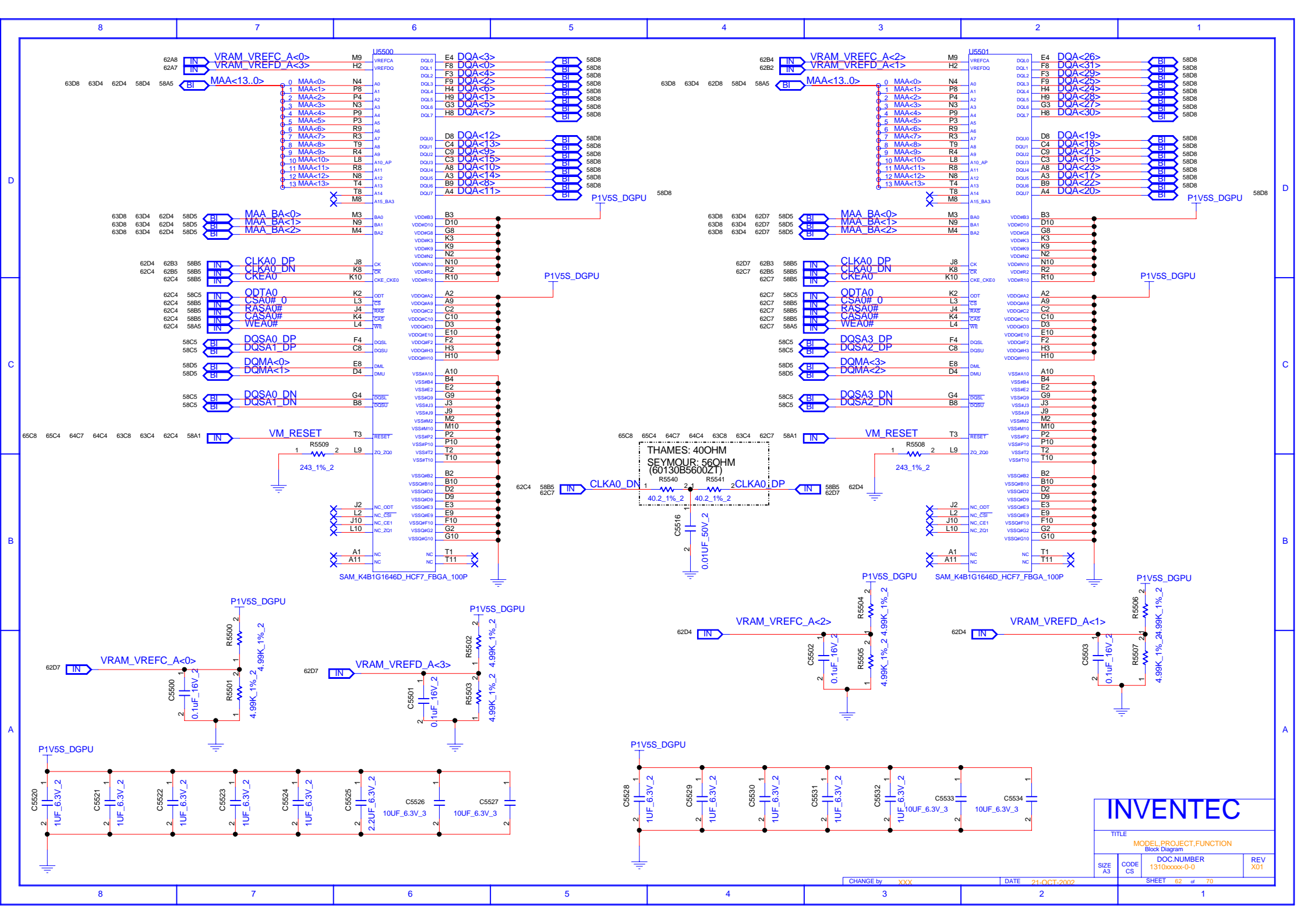

INVENTEC			
TITLE			
MODEL PROJECT FUNCTION			
Block Diagram			
SIZE	CODE	DOC NUMBER	REV
A3	CS	1310xxxx-0-0	X01
CHANGE by XXX		DATE 21-OCT-2002	SHEET 62 of 70

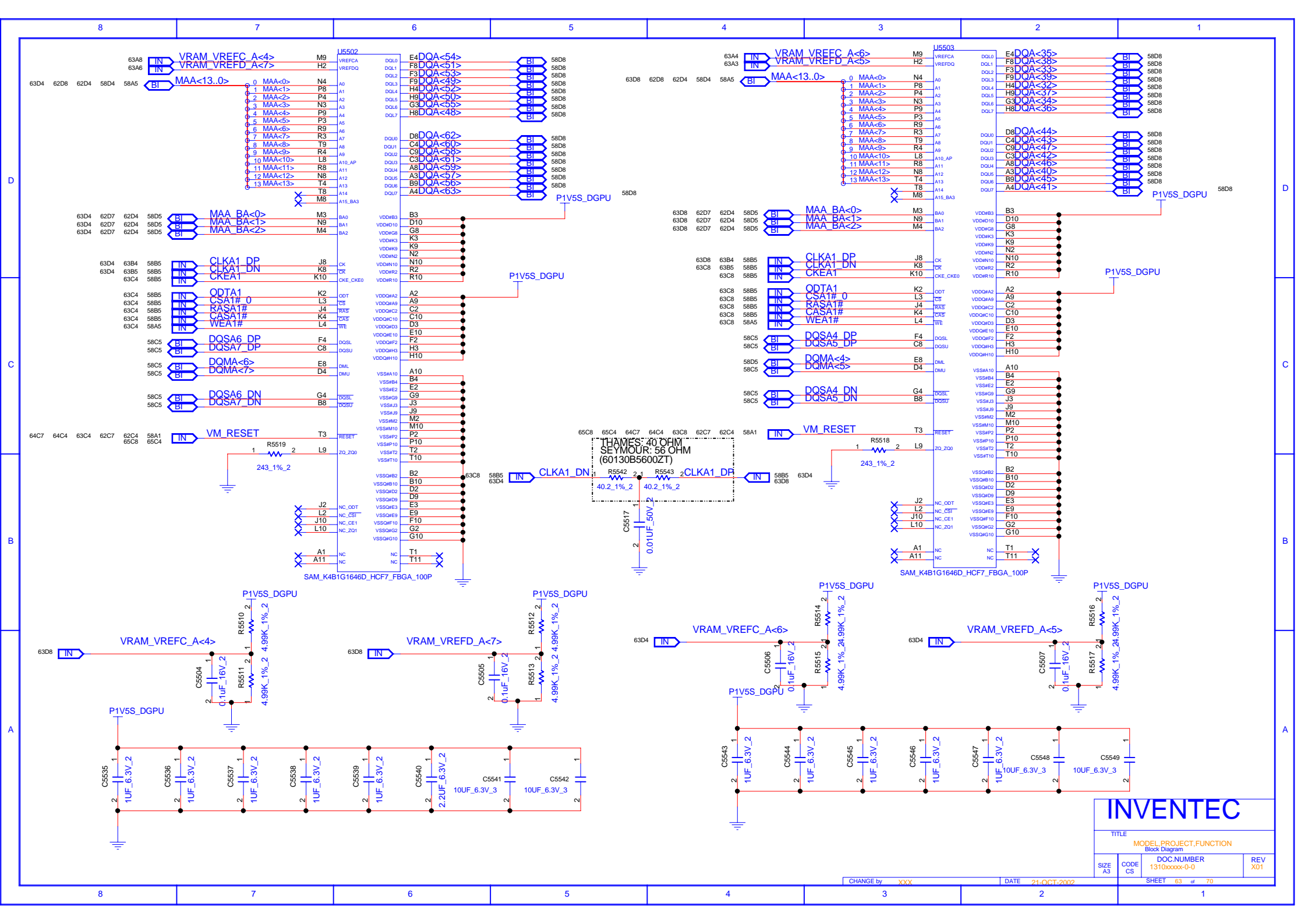

INVENTEC

TITLE			
MODEL PROJECT FUNCTION			
Block Diagram			
SIZE A3	CODE CS	DOC NUMBER 1310xxxx-0-0	REV X01

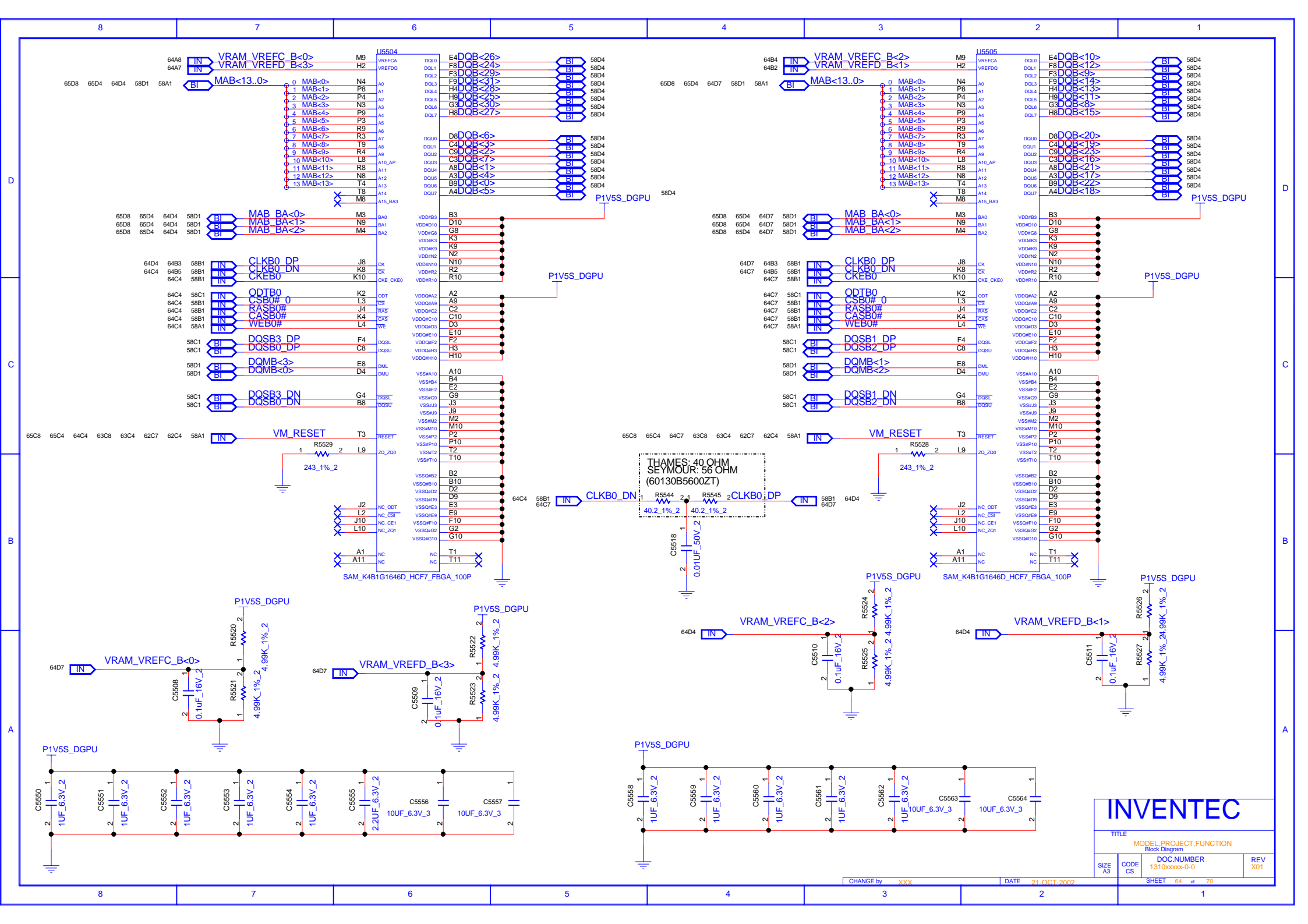

INVENTEC			
TITLE MODEL PROJECT FUNCTION Block Diagram			
SIZE A3	CODE CS	DOC NUMBER 1310xxxx-0-0	REV X01
CHANGE by XXX		DATE 21-OCT-2002	SHEET 64 of 70

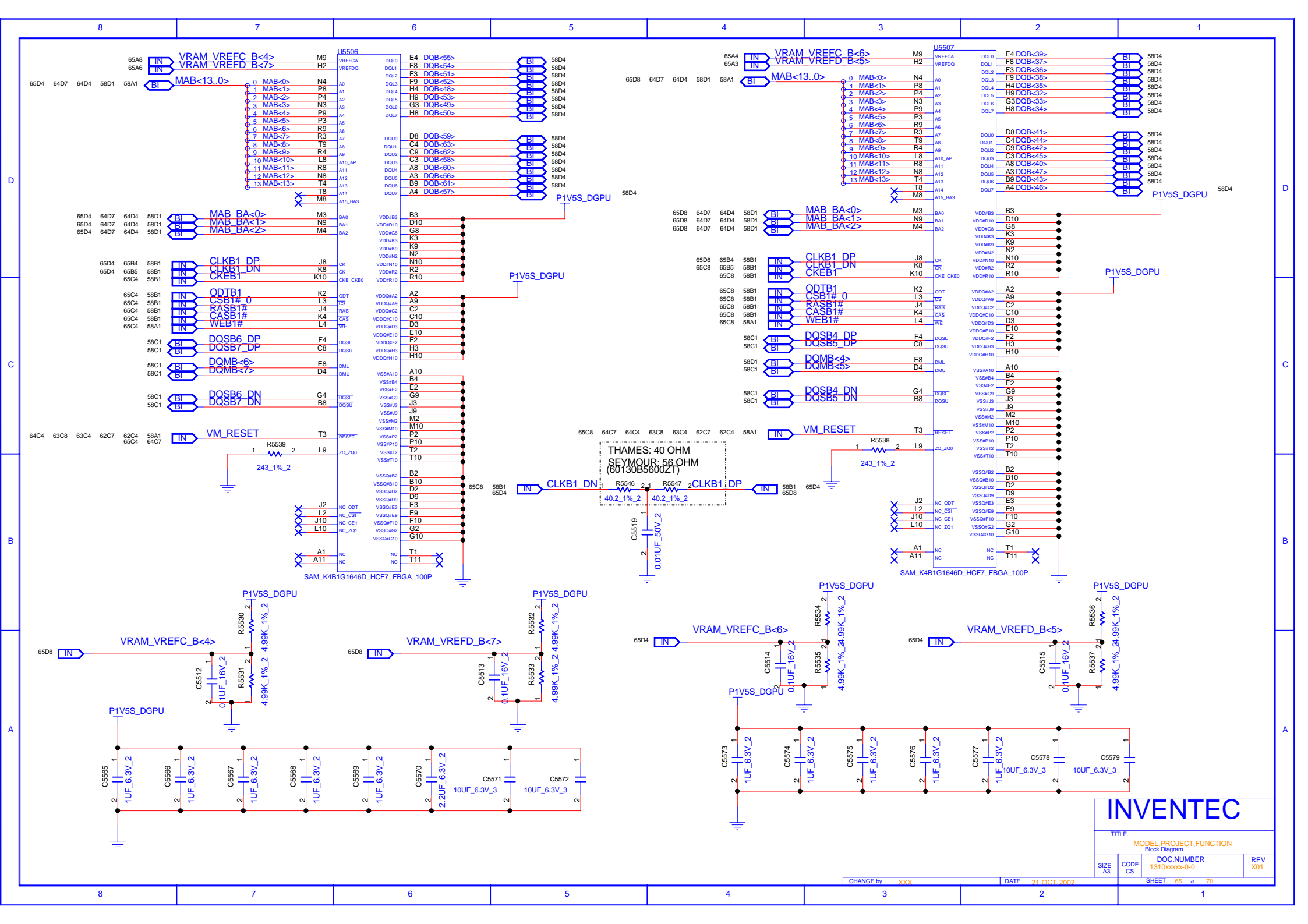

INVENTEC

TITLE			
MODEL PROJECT.FUNCTION			
Block Diagram			
SIZE	CODE	DOC NUMBER	REV
A3	CS	1310xxxx-0-0	X01
CHANGE by XXX		DATE 21-OCT-2002	SHEET 65 of 70

USB BOARD

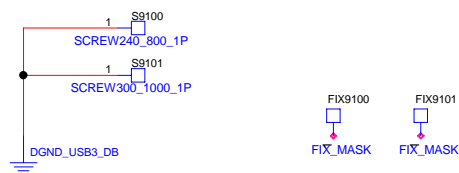
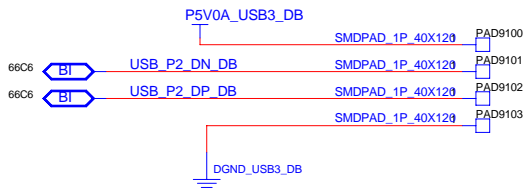
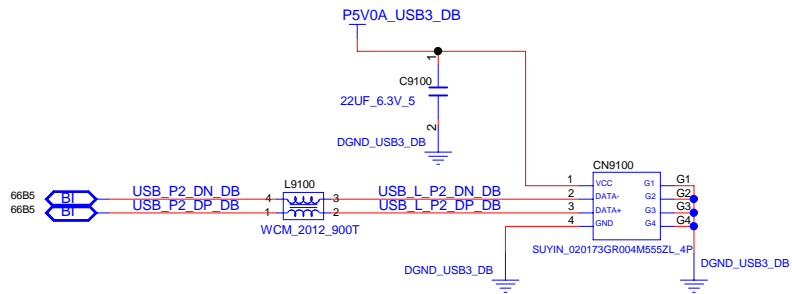

INVENTEC

TITLE			
MODEL,PROJECT,FUNCTION			
Block Diagram			
SIZE	CODE	DOC NUMBER	REV
A3	CS	1310xxxx-0-0	X01

TOUCH PAD BOARD 4 PIN

TOUCHPAD TO MODULE CONN

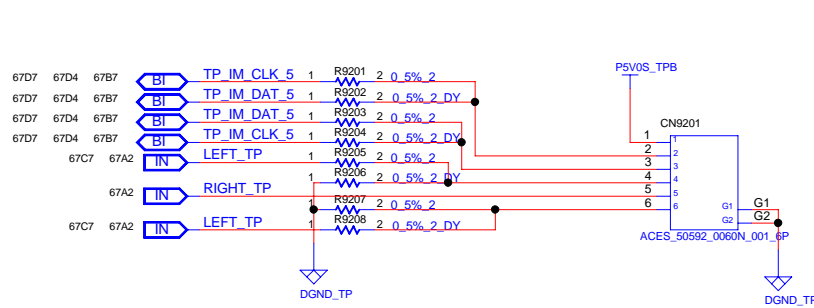

TOUCHPAD TO MB CONN

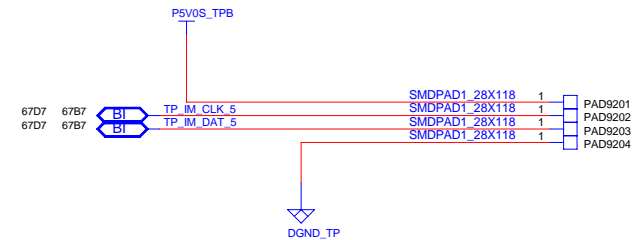

4PIN	IMR/METAL	TEXTURE
R9201		V
R9202	V	
R9203		V
R9204	V	
R9205		V
R9206	V	
R9207		V
R9208	V	
R9213	V	V
R9214	V	V

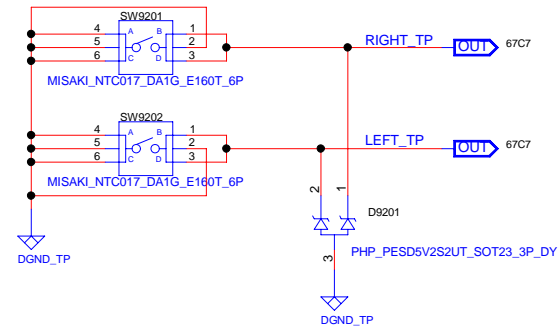
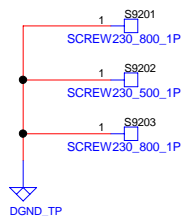
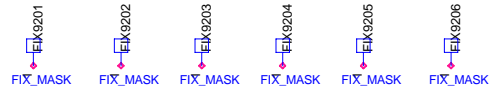
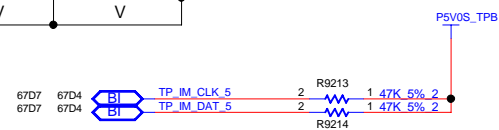

INVENTEC

TITLE			
MODEL PROJECT.FUNCTION			
Block Diagram			
SIZE	CODE	DOC NUMBER	REV
A3	CS	1310xxxx-0-0	X01

REFERENCE 9000~9999(SMALL BOARD)

POWER BUTTON

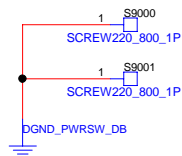
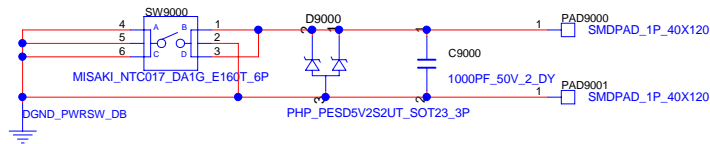

INVENTEC

TITLE			
MODEL,PROJECT,FUNCTION			
Block Diagram			
SIZE	CODE	DOC NUMBER	REV
A3	CS	1310xxxxx-0-0	X01

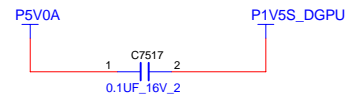
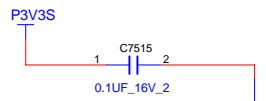
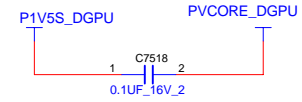
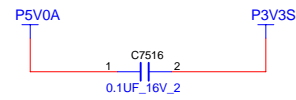
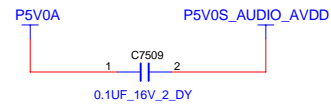
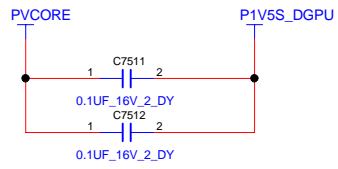
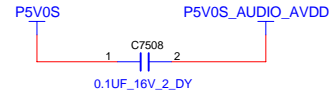
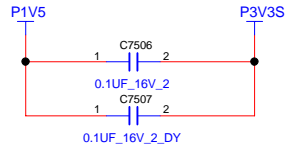
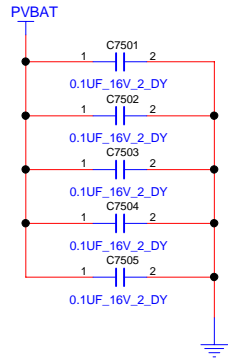

INVENTEC

TITLE			
MODEL, PROJECT, FUNCTION			
Block Diagram			
SIZE	CODE	DOC NUMBER	REV
A3	CS	1310xxxx-0-0	X01

TOUCH PAD BOARD 8 PIN

TOUCHPAD TO MODULE CONN

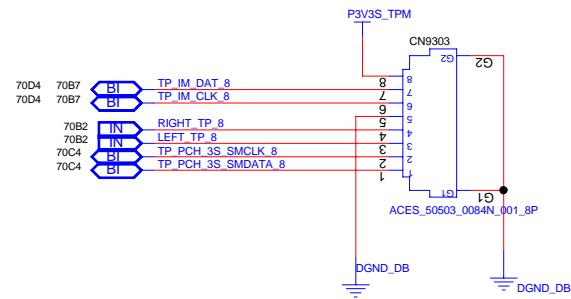

TOUCHPAD TO MB CONN

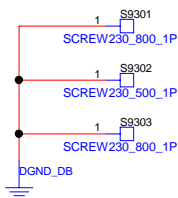
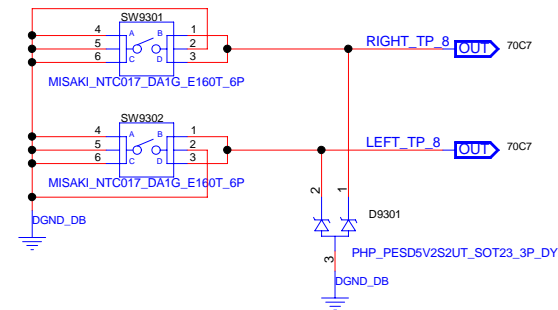
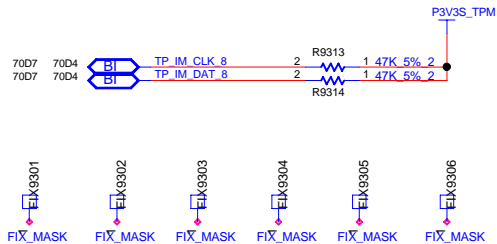
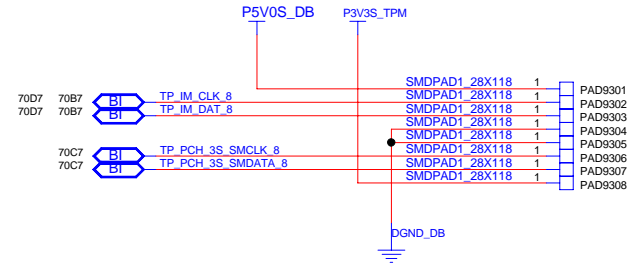

INVENTEC

TITLE			
MODEL PROJECT FUNCTION			
Block Diagram			
SIZE	CODE	DOC NUMBER	REV
A3	CS	1310xxxx-0-0	X01