

Discrete/UMA Schematics Document

Sandy Bridge

Intel PCH

2011-01-04

REV : A00

DY :None Installed

UMA:UMA ONLY installed

DN15: ONLY FOR DN15 installed.

DQ15:ONLY FOR DQ15 installed.

PSL: KBC795 PSL circuit for 10mW solution installed.

10mW: External circuit for 10mW solution installed.

MUXLESS:MUXLESS solution installed.

OPTIMUS:OPTIMUS solution installed.

<Core Design>



Title		
Cover Page		
Size A3	Document Number QUEEN 15	Rev A00
Date: Tuesday, January 04, 2011	Sheet 1	of 108

Block Diagram (Discrete/UMA co-lay)

SYSTEM LDO APL5916 48		CPU DC/DC ISL95831HRTZ 42~43	
INPUTS	OUTPUTS	INPUTS	OUTPUTS
1D05V_VTT	0D85V_S0	DCBATOUT	VCC_CORE
SYSTEM DC/DC TPS51218 45		SYSTEM DC/DC TPS51123RGER 41	
INPUTS	OUTPUTS	INPUTS	OUTPUTS
DCBATOUT	1D05V_VTT	DCBATOUT	5V_AUX_S5 3D3V_AUX_S5 5V_S5 3D3V_S5 15V_S5
SYSTEM DC/DC TPS51216RUKR 46		SYSTEM DC/DC ISL95831HRTZ 44	
INPUTS	OUTPUTS	INPUTS	OUTPUTS
DCBATOUT	1D5V_S3 0D75V_S0 DDR_VREF_S3	DCBATOUT	VCC GFXCORE
VGA RT8208B 92		TI CHARGER BQ24745 40	
INPUTS	OUTPUTS	INPUTS	OUTPUTS
DCBATOUT	VGA_CORE	+DC_IN_S5 +PBATT	DCBATOUT
SYSTEM DC/DC TPS51311 47		SYSTEM DC/DC G9731 93	
INPUTS	OUTPUTS	INPUTS	OUTPUTS
3D3V_S5	1D8V_S0	1D5V_S3	1V_VGA_S0
Switches			
INPUTS	OUTPUTS	INPUTS	OUTPUTS
1D5V_S3 5V_S5 3D3V_S5	1D5V_S0 5V_S0 3D3V_S0	1D5V_S0 5V_S0 3D3V_S0	1D5V_S0 5V_S0 3D3V_S0
PCB LAYER			
L1:Top	L4:Signal	L2:VCC	L5:GND
L3:Signal	L6:Bottom		

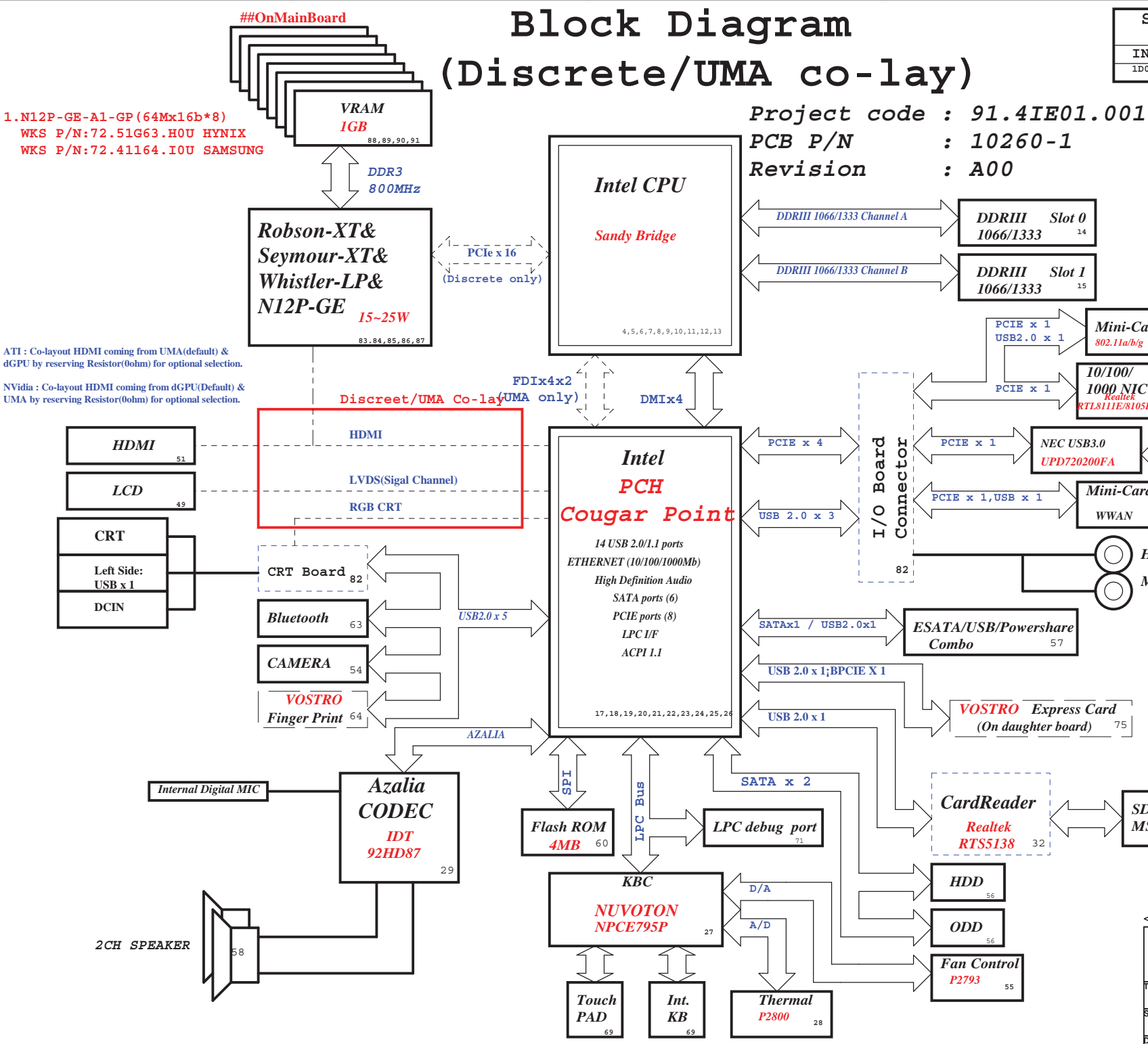

<Core Design>

Wistron Corporation
21F, 88, Sec. 1, Hsin Tai Wu Rd., Hsichih, Taipei Hsien 221, Taiwan, R.O.C.

Title: **Block Diagram**

Size: A3	Document Number: QUEEN 15	Rev: A00
Date: Tuesday, January 04, 2011	Sheet: 2 of 108	

Name	Schematics Notes
SPKR	Reboot option at power-up Default Mode: Internal weak Pull-down. No Reboot Mode with TCO Disabled: Connect to Vcc3_3 with 8.2-kf[- 10-kf[weak pull-up resistor.
INIT3_3V#	Weak internal pull-up. Leave as "No Connect".
GNT3#/GPIO55 GNT2#/GPIO53 GNT1#/GPIO51	GNT[3:0]# functionality is not available on Mobile. Mobile: Used as GPIO only Pull-up resistors are not required on these signals. If pull-ups are used, they should be tied to the Vcc3_3power rail.
SPI_MOSI	Enable Danbury: Connect to Vcc3_3 with 8.2-k? weak pull-up resistor. Disable Danbury: Left floating, no pull-down required.
NV_ALE	Enable Danbury: Connect to +NVRAM_VCCQ with 8.2-kohm weak pull-up resistor [CRB has it pulled up with 1-kohm no-stuff resistor] Disable Danbury: Leave floating (internal pull-down)
NC_CLE	DMI termination voltage. Weak internal pull-up. Do not pull low.
HAD_DOCK_EN# /GPIO[33]	Low (0) - Flash Descriptor Security will be overridden. Also, when this signals is sampled on the rising edge of PWROK then it will also disable Intel ME and its features. High (1) - Security measure defined in the Flash Descriptor will be enabled. Platform design should provide appropriate pull-up or pull-down depending on the desired settings. If a jumper option is used to tie this signal to GND as required by the functional strap, the signal should be pulled low through a weak pull-down in order to avoid asserting HDA_DOCK_EN# inadvertently. Note: CRB recommends 1-kohm pull-down for FD Override. There is an internal pull-up of 20 kohm for DA_DOCK_EN# which is only enabled at boot/reset for strapping functions.
HDA_SDO	Weak internal pull-down. Do not pull high. Sampled at rising edge of RSMRST#.
HDA_SYNC	Weak internal pull-down. Do not pull high. Sampled at rising edge of RSMRST#.
GPIO15	Low (1) - Intel ME Crypto Transport Layer Security (TLS) cipher suite with no confidentiality High (1) - Intel ME Crypto Transport Layer Security (TLS) cipher suite with confidentiality Note : This is an un-muxed signal. This signal has a weak internal pull-down of 20 kohm which is enabled when PWROK is low. Sampled at rising edge of RSMRST#. CRB has a 1-kohm pull-up on this signal to +3.3VA rail.
GPIO8	GPIO8 on PCH is the Integrated Clock Enable strap and is required to be pulled-down using a 1k +/- 5% resistor. When this signal is sampled high at the rising edge of RSMRST#, Integrated Clocking is enabled, When sampled low, Buffer Through Mode is enabled.
GPIO27	Default = Do not connect (floating) High(1) = Enables the internal VccVRM to have a clean supply for analog rails. No need to use on-board filter circuit. Low (0) = Disables the VccVRM. Need to use on-board filter circuits for analog rails.

Pin Name	Strap Description	Configuration (Default value for each bit is 1 unless specified otherwise)	Default Value
CFG[2]	PCI-Express Static Lane Reversal	1: Normal Operation. 0: Lane Numbers Reversed 15 -> 0, 14 -> 1, ...	1
CFG[4]		Disabled - No Physical Display Port attached to 1: Embedded DisplayPort. Enabled - An external Display Port device is connect to the EMBEDDED display Port 0:	0
CFG[6:5]	PCI-Express Port Bifurcation Straps	11 : x16 - Device 1 functions 1 and 2 disabled 10 : x8, x8 - Device 1 function 1 enabled ; function 2 disabled 01 : Reserved - (Device 1 function 1 disabled ; function 2 enabled) 00 : x8, x4, x4 - Device 1 functions 1 and 2 enabled	11
CFG[7]	PEG DEFER TRAINING	1: PEG Train immediately following xxRESETB de assertion 0: PEG Wait for BIOS for training	

POWER PLANE	VOLTAGE	Voltage Rails		DESCRIPTION
		ACTIVE IN		
5V_S0 3D3V_S0 1D8V_S0 1D5V_S0 1D05V_VTT 0D85V_S0 0D75V_S0 VCC_CORE VCC_OFXCORE 1D8V_VGA_S0 3D3V_VGA_S0 1V_VGA_S0	5V 3.3V 1.8V 1.5V 1.05V 0.95 - 0.85V 0.75V 0.35V to 1.5V 0.4 to 1.25V 1.8V 3.3V 1V	S0		CPU Core Rail Graphics Core Rail
5V_USBX_S3 1D5V_S3 DDR_VREF_S3	5V 1.5V 0.75V	S3		
BT+ DCBATOUT 5V_S5 5V_AUX_S5 3D3V_S5 3D3V_AUX_S5	6V-14.1V 6V-14.1V 5V 5V 3.3V 3.3V	All S states		AC Brick Mode only
3D3V_LAN_S5	3.3V	WOL_EN		Legacy WOL
3D3V_AUX_KBC	3.3V	DSW, Sx		ON for supporting Deep Sleep states
3D3V_AUX_S5	3.3V	G3, Sx		Powered by Li Coin Cell in G3 and +V3ALW in Sx

USB Table

Pair	Device
0	Touch Panel / 3G SIM
1	USB Ext. port 1 (HS)
2	Fingerprint
3	BLUETOOTH
4	Mini Card2 (WWAN)
5	CARD READER
6	X
7	X
8	USB Ext. port 4 / E-SATA / USB CHARGER
9	USB Ext. port 2
10	USB Ext. port 3
11	Mini Card1 (WLAN)
12	CAMERA
13	Express Card

PCIE Routing

LANE1	Card Reader
LANE2	Mini Card1 (WLAN)
LANE3	Mini Card2 (WWAN)
LANE4	Onboard LAN
LANE5	USB3.0
LANE6	Intel GBE LAN
LANE7	Dock
LANE8	Express Card

SATA Table

SATA	
Pair	Device
0	HDD1
1	HDD2
2	N/A
3	N/A
4	ODD
5	ESATA

SMBus ADDRESSES

I ² C / SMBus Addresses	Ref Des	HURON RIVER ORB		
		Address	Hex	Bus
EC SMBus 1 Battery CHARGER				BAT_SCL/BAT_SDA BAT_SCL/BAT_SDA BAT_SCL/BAT_SDA
EC SMBus 2 PCH eDP				SML1_CLK/SML1_DATA SML1_CLK/SML1_DATA SML1_CLK/SML1_DATA
PCH SMBus SO-DIMMA (SPD) SO-DIMMB (SPD) Digital Pot G-Sensor MINI				PCH_SMBDATA/PCH_SMBCLK PCH_SMBDATA/PCH_SMBCLK PCH_SMBDATA/PCH_SMBCLK PCH_SMBDATA/PCH_SMBCLK PCH_SMBDATA/PCH_SMBCLK PCH_SMBDATA/PCH_SMBCLK

Variant Names

DELL Wistron Corporation
 21F, 88, Sec.1, Hsin Tai Wu Rd., Hsichih, Taipei Hsien 221, Taiwan, R.O.C.

Table of Content

Size A3 Document Number **QUEEN 15** Rev **A00**
 Date: Tuesday, January 04, 2011 Sheet 3 of 108

Note: Intel DMI supports both Lane Reversal and polarity inversion but only at PCH side. This is enabled via a soft strap.

Note: Intel FDI supports both Lane Reversal and polarity inversion but only at PCH side. This is enabled via a soft strap.

Note: Lane reversal does not apply to FDI sideband signals.

Signal Routing Guideline: EDP_ICOMPO keep W/S=12/15 mils and routing length less than 500 mils. EDP_COMPIO keep W/S=4/15 mils and routing length less than 500 mils.

NOTE: Processor strap CFG[4] should be pulled low to enable Embedded DisplayPort.

Stuff to disable internal graphics function for power saving.

NOTE: Select a Fast FET similar to 2N7002E whose rise/fall time is less than 6 ns. If HPD on eDP interface is disabled, connect it to CPU VCCIO via a 10-kΩ pull-Up resistor on the motherboard.

Signal Routing Guideline: PEG_ICOMPO keep W/S=12/15 mils and routing length less than 500 mils. PEG_ICOMPI & PEG_RCOPMO keep W/S=4/15 mils and routing length less than 500 mils.

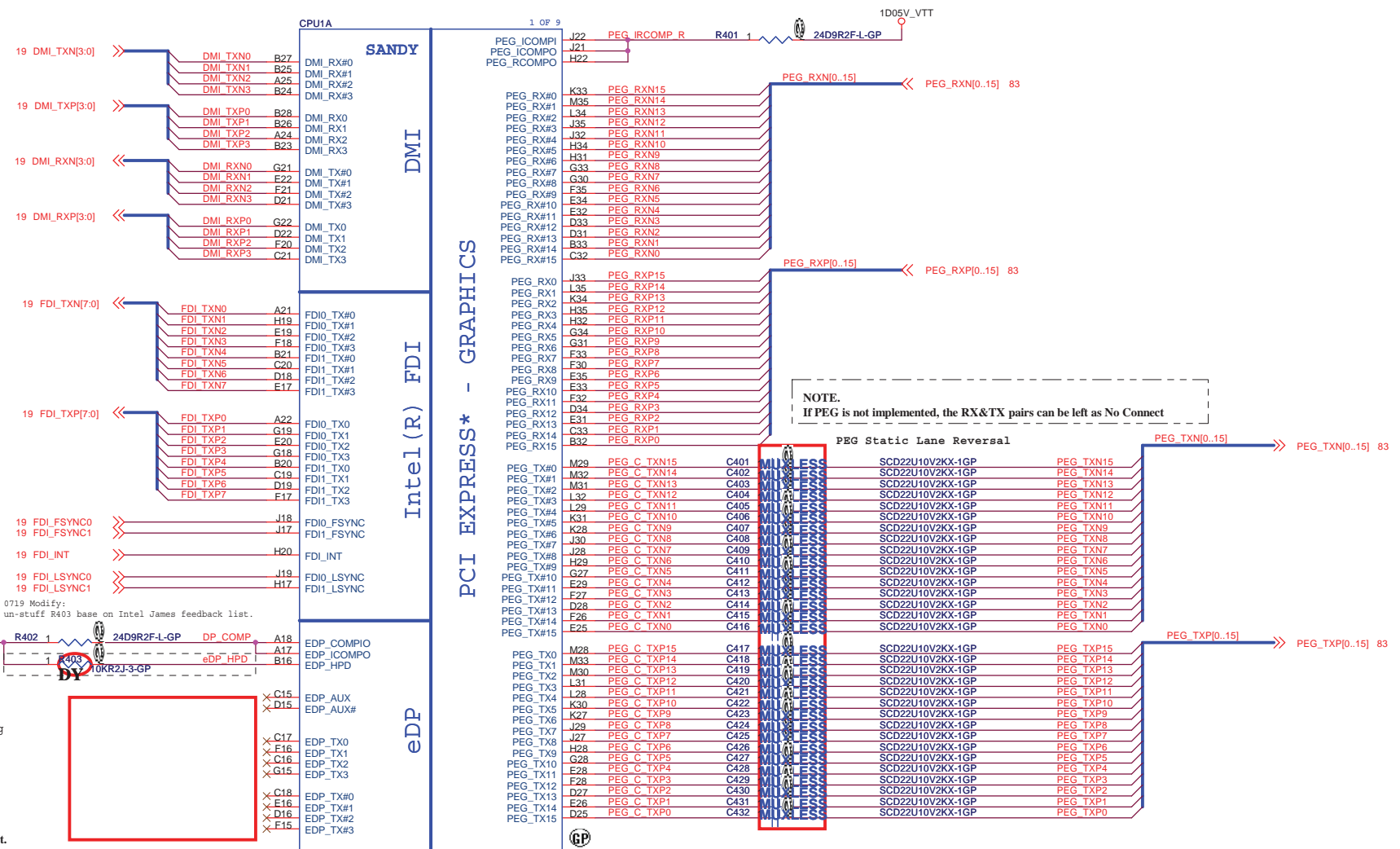

NOTE: If PEG is not implemented, the RX&TX pairs can be left as No Connect

PEG Static Lane Reversal

Table with columns for PEG RX#, PEG TX#, and PEG TXN#. It lists lane reversal configurations for various PEG lanes (RX0-RX15, TX0-TX15) and includes a note about RX&TX pairs.

SANDY SKT-BGA989C470395-1H180 62.10055.421 2nd = 62.10040.771 3rd = 62.10055.321

A00 0103 add 3rd foxconn CPU1 at XBuild batch run

<Variant Name>

Dell Wistron Corporation logo and address. Title: CPU (PCIe/DMI/FDI). Size A3. Document Number: QUEEN 15. Rev: A00. Date: Tuesday, January 04, 2011. Sheet 4 of 108.

SSID = CPU

0625 Modify: Add C502 47pF 0402 on H_PROCHOT#.

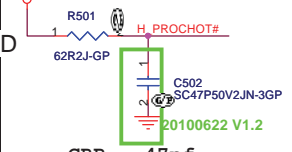

CRB : 47pf

CEKLT: 43pf

Connect EC to PROCHOT# through inverting OD buffer.

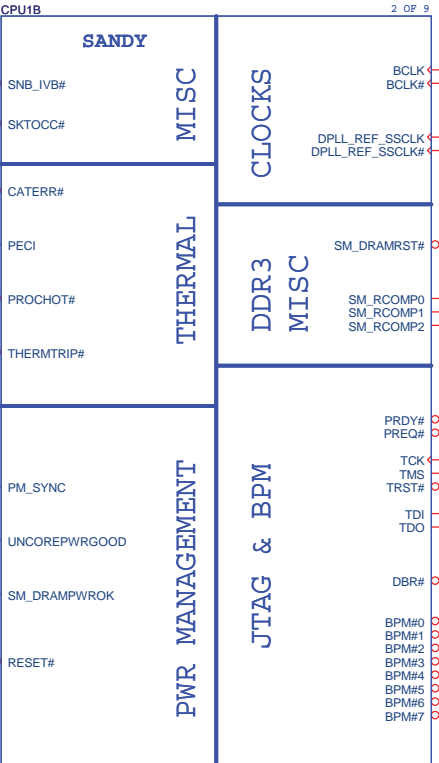
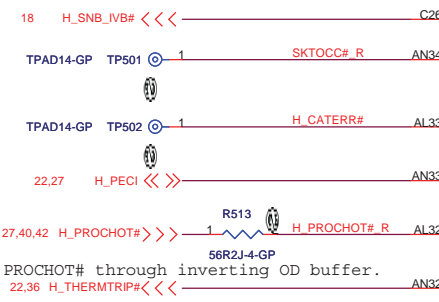

SANDY SKT-BGA989C470395-1H180
62.10055.421

2nd = 62.10040.771

3rd = 62.10055.321

A00 0103 add 3rd foxconn CPU1 at XBuild batch run

0617 Modify: Joseph Removed U501 Buffer reset to CPU circuit.

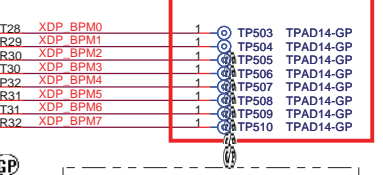
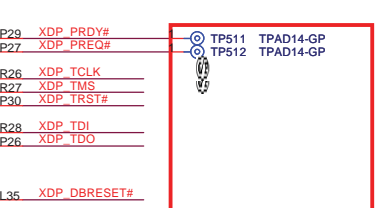
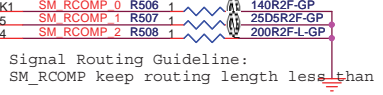
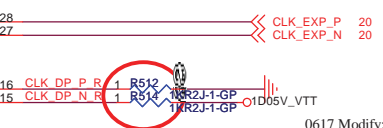
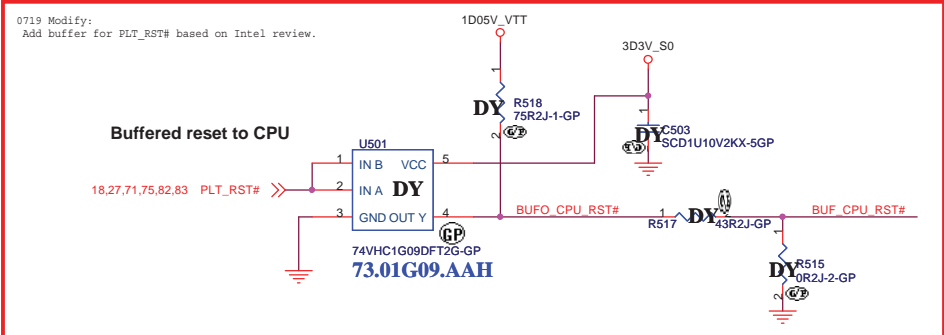

0630 Modify: Removed XDP1101 connector related circuit by layout limitation.

Disabling Guidelines:
If motherboard only supports external graphics:
Connect DPLL_REF_SSCLK on Processor to GND through 1K +/- 5% resistor.
Connect DPLL_REF_SSCLK# on Processor to VCCP through 1K +/- 5% resistor power (~15 mW) may be wasted.

0617 Modify: Joseph change RN501 to R512.R514 1K 0402 Resistor.

Signal Routing Guideline:
SM_RCOMP keep routing length less than 500 mils.

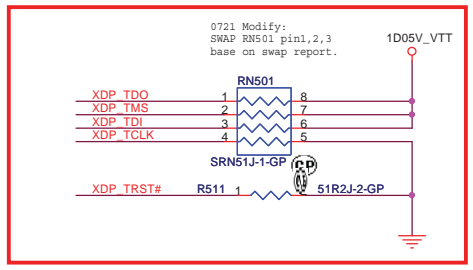

19 XDP_DBRESET#

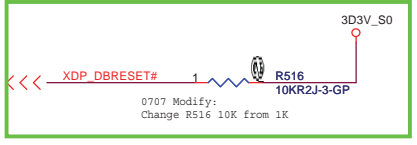

A00 1229 EMI

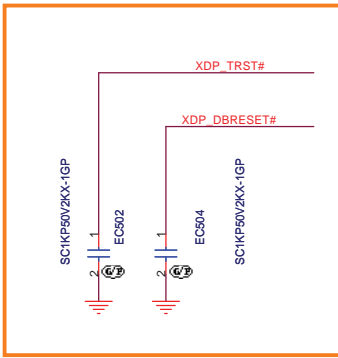

<Variant Names>

Dell Wistron Corporation logo and address. Title: CPU (THERMAL/CLOCK/PM). Size A3, Document Number: QUEEN 15, Rev A00. Date: tuesday, January 04, 2011. Sheet 5 of 108.

SSID = CPU

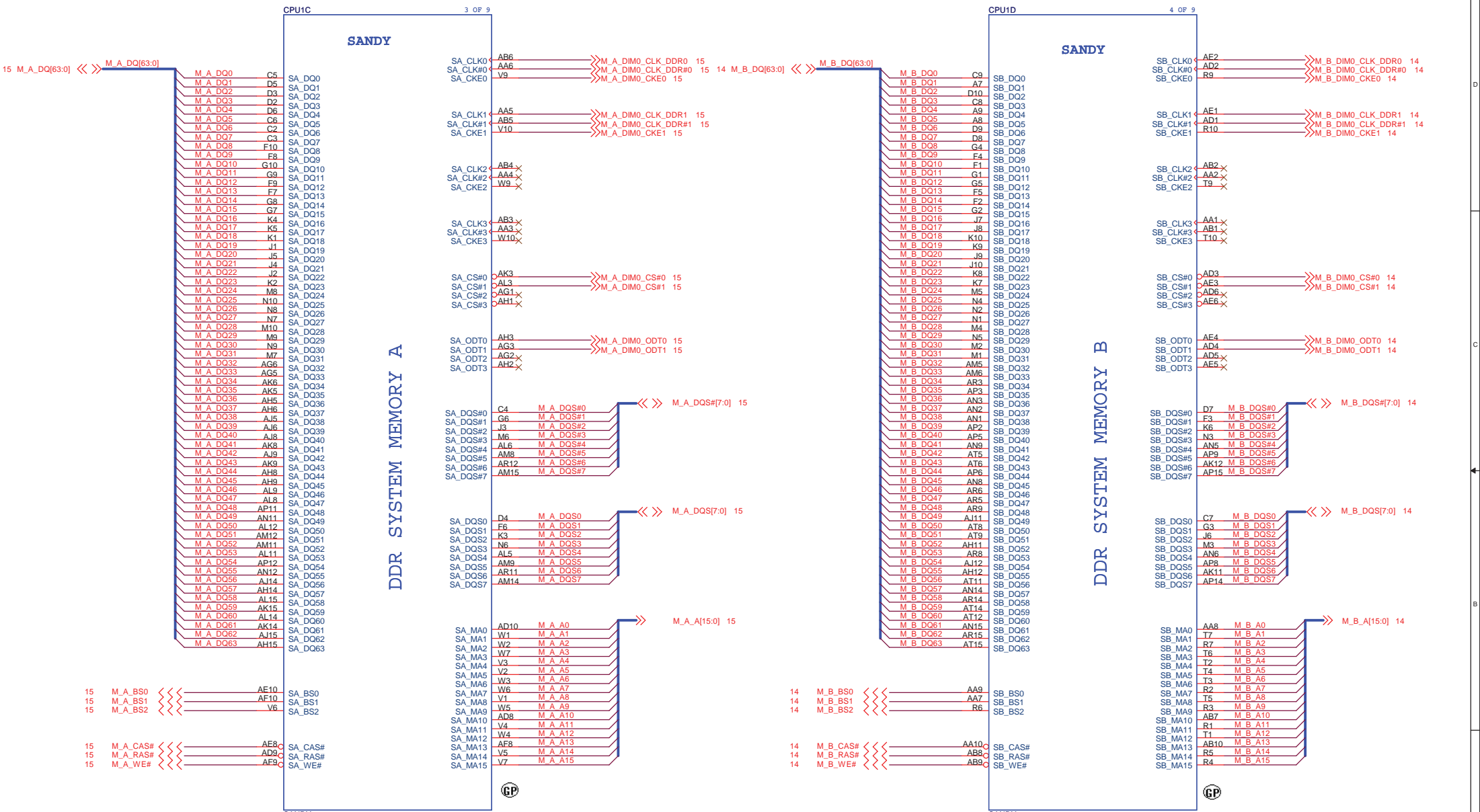

SANDY
62.10055.421
2nd = 62.10040.771
3rd = 62.10055.321

A00 0103 add 3rd foxconn CPU1 at XBuild batch run

SANDY
62.10055.421
2nd = 62.10040.771
3rd = 62.10055.321

A00 0103 add 3rd foxconn CPU1 at XBuild batch run

<Variant Name>



Title CPU (DDR)		
Size A3	Document Number QUEEN 15	Rev A00
Date: Tuesday, January 04, 2011	Sheet 6	of 108

SSID = CPU

0630 Modify:
Reserved TP715 on CFG0.



0707 Modify:
Removed CFG1, CFG3, CFG8-17 TP.

0617 Modify:
Joseph Change M_VREF_DQ_DIMM0, M_VREF_DQ_DIMM1, M_VREF_CA_DIMM0, M_VREF_CA_DIMM1 from net to power.

M3 - Processor Generated SO-DIMM VREF_DQ

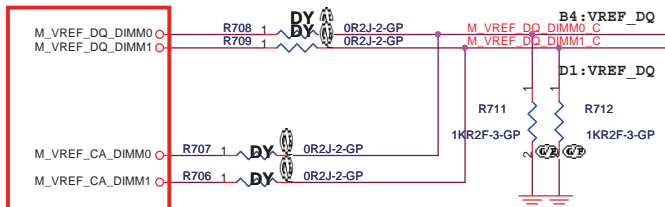

20 mils

0629 Modify:
Reserved R710 0ohm to GND to follow EV board schematic.

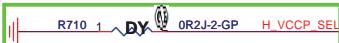

1D05V_VTT



0719 Modify:
Reserved EC701 0.1uF near R711(BOTTOM) for EMC NEO suggestion.

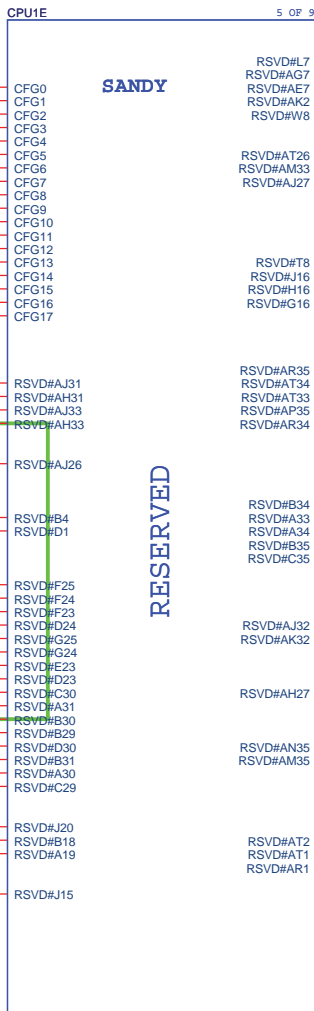

SANDY **SKT-BGA989C470395-1H180**
62.10055.421
2nd = 62.10040.771
3rd = 62.10055.321 A00 0103 add 3rd foxconn CPU1 at XBuild batch run

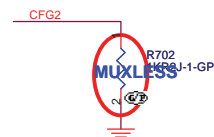

PEG Static Lane Reversal	
CFG2	1: Normal Operation; Lane # definition matches socket pin map definition
	0: Lane Reversed

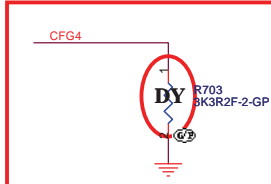

Display Port Presence Strap	
CFG4	1: Disabled; No Physical Display Port attached to Embedded Display Port
	0: Enabled; An external Display Port device is connected to the Embedded Display Port

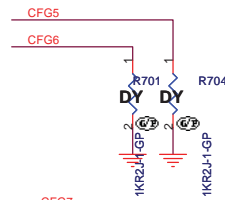

PCIe Port Bifurcation Straps	
CFG[6:5]	11: x16 - Device 1 functions 1 and 2 disabled
	10: x8, x8 - Device 1 function 1 enabled ; function 2 disabled
	01: Reserved - (Device 1 function 1 disabled ; function 2 enabled)
	00: x8, x4, x4 - Device 1 functions 1 and 2 enabled

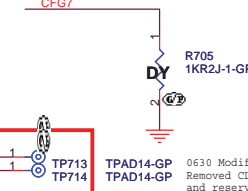

PEG DEPER TRAINING	
CFG7	1: PEG Train immediately following xxRESETB de assertion
	0: PEG Wait for BIOS for training

0702 Modify:
Removed CLK_XDP ITP PaN and reserved TP713, TP714.

<Variant Name>

Wistron Corporation
 21F, 88, Sec.1, Hsin Tai Wu Rd., Hsichih, Taipei Hsien 221, Taiwan, R.O.C.

Title: **CPU (RESERVED)**

Size A3	Document Number	Rev
	QUEEN 15	A00
Date: Tuesday, January 04, 2011	Sheet 7 of	108

Voltage Rail	Voltage	Iccmax
VCC_CORE(QC)	0.8~1.35	94A
VCC_CORE(DC)	0.8~1.35	53A
VCCIO	1.05	8.5A
VDDQ	1.5	10A
VCCSA	0.75~0.9	6A
VCCPLL	1.8	1.2A
VAXG	0~1.52	33A

1115 X02 Modify:
Reserved C802-C804, C806, C807 10uF 0603
for power team fine tune Vcore quality.

PROCESSOR CORE POWER

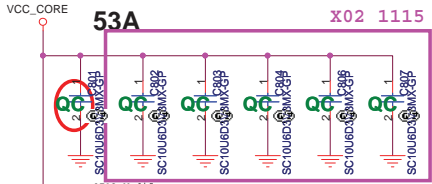

0713 Modify:
Removed C802, C811 10uF 0603
cap base on layout limitation.

0713 Modify:
Removed C818 10uF 0603
base on layout limitation.

0726 Modify:
un-stuff C826

0721 Modify:
Removed C836.

0726 Modify:
un-stuff C837.

VCC Output Decoupling Recommendation:
4 x 470 uF at Bottom Socket Edge
8 x 22 uF at Top Socket Cavity
8 x 22 uF at Top Socket Edge
8 x 22 uF at Bottom Socket Cavity

- VCC CORE
- AG35 VCC
- AG34 VCC
- AG33 VCC
- AG32 VCC
- AG31 VCC
- AG30 VCC
- AG29 VCC
- AG28 VCC
- AG27 VCC
- AG26 VCC
- AF35 VCC
- AF34 VCC
- AF33 VCC
- AF32 VCC
- AF31 VCC
- AF30 VCC
- AF29 VCC
- AF28 VCC
- AF27 VCC
- AF26 VCC
- AD35 VCC
- AD34 VCC
- AD33 VCC
- AD32 VCC
- AD31 VCC
- AD30 VCC
- AD29 VCC
- AD28 VCC
- AD27 VCC
- AD26 VCC
- AC35 VCC
- AC34 VCC
- AC33 VCC
- AC32 VCC
- AC31 VCC
- AC30 VCC
- AC29 VCC
- AC28 VCC
- AC27 VCC
- AC26 VCC
- AA35 VCC
- AA34 VCC
- AA33 VCC
- AA32 VCC
- AA31 VCC
- AA30 VCC
- AA29 VCC
- AA28 VCC
- AA27 VCC
- AA26 VCC
- Y35 VCC
- Y34 VCC
- Y33 VCC
- Y32 VCC
- Y31 VCC
- Y30 VCC
- Y29 VCC
- Y28 VCC
- Y27 VCC
- Y26 VCC
- Y25 VCC
- Y24 VCC
- Y23 VCC
- Y22 VCC
- Y21 VCC
- Y20 VCC
- Y19 VCC
- Y18 VCC
- Y17 VCC
- Y16 VCC
- Y15 VCC
- Y14 VCC
- Y13 VCC
- Y12 VCC
- Y11 VCC
- Y10 VCC
- Y9 VCC
- Y8 VCC
- Y7 VCC
- Y6 VCC
- Y5 VCC
- Y4 VCC
- Y3 VCC
- Y2 VCC
- Y1 VCC
- U35 VCC
- U34 VCC
- U33 VCC
- U32 VCC
- U31 VCC
- U30 VCC
- U29 VCC
- U28 VCC
- U27 VCC
- U26 VCC
- U25 VCC
- U24 VCC
- U23 VCC
- U22 VCC
- U21 VCC
- U20 VCC
- U19 VCC
- U18 VCC
- U17 VCC
- U16 VCC
- U15 VCC
- U14 VCC
- U13 VCC
- U12 VCC
- U11 VCC
- U10 VCC
- U9 VCC
- U8 VCC
- U7 VCC
- U6 VCC
- U5 VCC
- U4 VCC
- U3 VCC
- U2 VCC
- U1 VCC
- R35 VCC
- R34 VCC
- R33 VCC
- R32 VCC
- R31 VCC
- R30 VCC
- R29 VCC
- R28 VCC
- R27 VCC
- R26 VCC
- P35 VCC
- P34 VCC
- P33 VCC
- P32 VCC
- P31 VCC
- P30 VCC
- P29 VCC
- P28 VCC
- P27 VCC
- P26 VCC

CORE SUPPLY

SVID

SENSE LINES

PEG AND DDR

- VCCIO AH13
- VCCIO AH10
- VCCIO AG10
- VCCIO Y10
- VCCIO U10
- VCCIO P10
- VCCIO J14
- VCCIO J13
- VCCIO J12
- VCCIO J11
- VCCIO H14
- VCCIO H12
- VCCIO H11
- VCCIO G14
- VCCIO G13
- VCCIO G12
- VCCIO F14
- VCCIO F13
- VCCIO F12
- VCCIO E14
- VCCIO E12
- VCCIO E11
- VCCIO D14
- VCCIO D13
- VCCIO D12
- VCCIO D11
- VCCIO C14
- VCCIO C13
- VCCIO C12
- VCCIO C11
- VCCIO B14
- VCCIO B12
- VCCIO A14
- VCCIO A13
- VCCIO A12
- VCCIO A11
- VCCIO J23

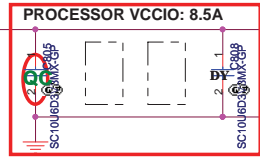

0713 Modify:
Removed C810, C806, C807 10uF 0603
base on layout limitation.

No-stuff sites outside the socket may be removed.
No-stuff sites inside the socket cavity need to remain.



0617 Modify:
Joseph Removed C812,
C813, C814

For CRB VIDSOUT need to pull high 130 ohm closer to CPU and IMVP7
For CRB VIDALERT# need to pull high 75 ohm close to CPU

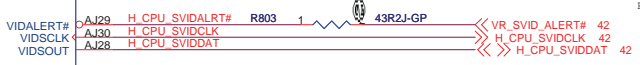

0705 Modify:
Removed R805, R806, already PH closed PWM side.

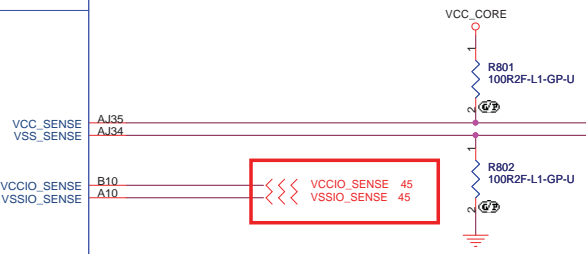

<Core Design>



Title			CPU (VCC CORE)		
Size	Document Number	Rev			
Custom	QUEEN 15	A00			
Date:	Tuesday, January 04, 2011	Sheet	8	of	108

SSID = CPU

VAXG Output Decoupling Recommendation:

- 2 x 470 uF at Bottom Socket Edge
- 2 x 22 uF at Top Socket Cavity
- 4 x 22 uF at Top Socket Edge
- 2 x 22 uF at Bottom Socket Cavity
- 4 x 22 uF at Bottom Socket Edge

0726 Modify:
un-stuff C906.

Voltage Rail	Voltage	Iccmax
VCC_CORE(QC)	0.8~1.35	94A
VCC_CORE(DC)	0.8~1.35	53A
VCCIO	1.05	8.5A
VDDQ	1.5	10A
VCCSA	0.75~0.9	6A
VCCPLL	1.8	1.2A
VAXG	0~1.52	33A

VCC_GFXCORE

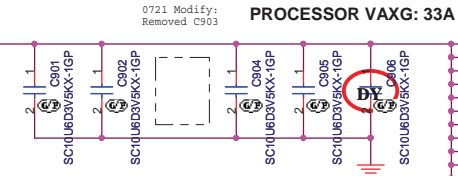

0624 Modify:
Removed C918,C919 10uF 0603 for VCC_GFXCORE.

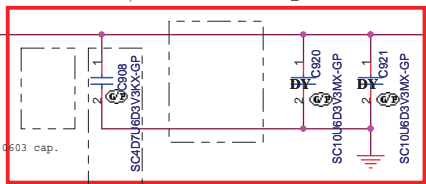

0713 Modify:
Removed C907 10uF 0603 cap.
0726 Modify:
stuff C908 10uF.

**Removed DIS_ONLY Disable Resistor.
R904,R905,R901,R903**

Disabling Guidelines for External Graphics Designs:
Can connect to GND if motherboard only supports external graphics and if GFX VR is not stuffed.
Can be left floating (Gfx VR keeps VAXG rail from floating) if the VR is stuffed

1D8V_S0

PROCESSOR VCCPLL: 1.2A

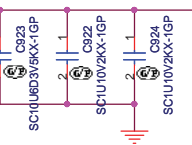

0617 Modify:
Joseph Removed TC902,
TC903 330uF cap.

VCCPLL Output Decoupling Recommendation:
1 x 330 uF
2 x 1 uF
1 x 10 uF

POWER

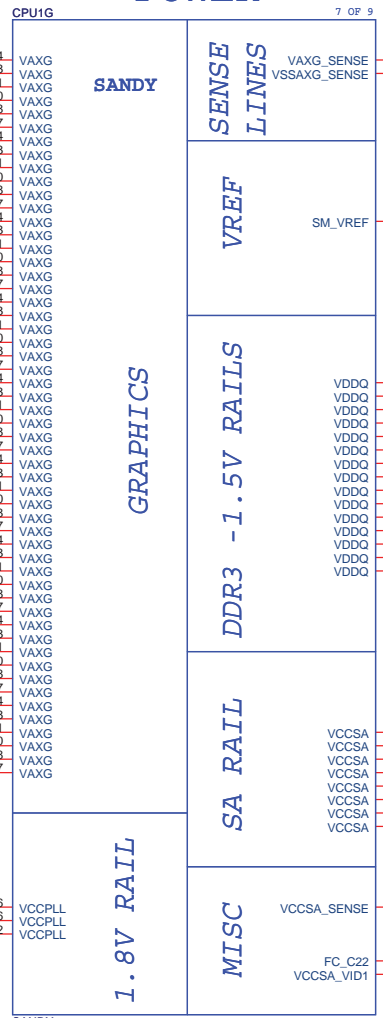

SANDY
62.10055.421
2nd = 62.10040.771
3rd = 62.10055.321

A00 0103 add 3rd foxconn CPU1 at XBuild batch run

VAXG Sense VSSAXG Sense
AK35 VCC_AXG_SENSE 42
AK34 VSS_AXG_SENSE 42

Refer to the latest Huron River Mainstream PDG (Doc# 436735) for more details on S3 power reduction implementation.

+V_SM_VREF_CNT should have 10 mil trace width

SM_VREF AL1 +V_SM_VREF_CNT <<< +V_SM_VREF_CNT 37

Routing Guideline:
Power from DDR_VREF_S3 and +V_SM_VREF_CNT should have 10 mils trace width.

PROCESSOR VDDQ: 10A

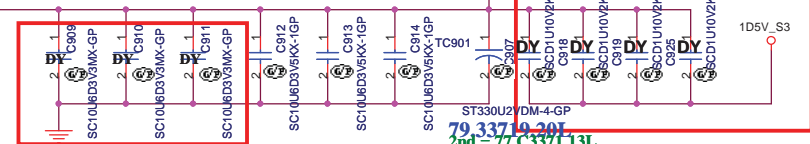

VDDQ Output Decoupling Recommendation:
1 x 330 uF
6 x 10 uF

0719 Modify:
Add C907,C918,C919,C925 0402 0.1 uF stitching capacitors between 1D5V_S3 & 1D5V_S0 based on Intel's review

PROCESSOR VCCSA: 6A

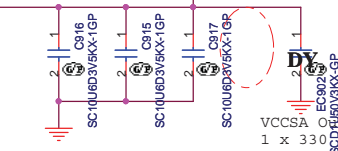

0617 Modify:
Joseph Removed TC902,TC903 330uF cap.
0719 Modify:
Reserved EC902 0.1uF near C917 for EMC NEO suggestion.

VCCSA Output Decoupling Recommendation:
1 x 330 uF
2 x 10 uF at Bottom Socket Cavity
1 x 10 uF at Bottom Socket Edge

0624 Modify:
Removed R902 10ohm closed CPU side.
0713 Modify:
Add R908 100ohm PH to 0D85V_S0.
0714 Modify:
Removed R908 PH.

VCCSA Sense H23 VCCUSA_SENSE >>> VCCUSA_SENSE 48

H_FC_C22 C22 H_FC_C22 48
VCCSA_SEL C24 VCCSA_SEL 48

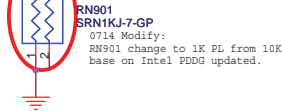

0714 Modify:
RN901 change to 1K PL from 10K base on Intel PDDG updated.



1122 X02 Modify:
stuff EC901 0.1uF from EMC Neo suggestion.

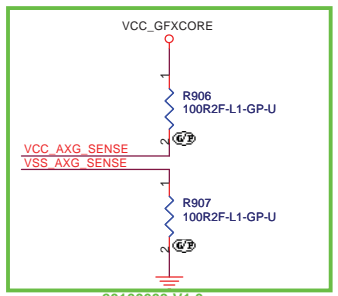

20100609 V1.0

<Core Design>



Title CPU (VCC GFXCORE)		
Size A3	Document Number QUEEN 15	Rev A00
Date: Tuesday, January 04, 2011	Sheet 9	of 108

SSID = CPU

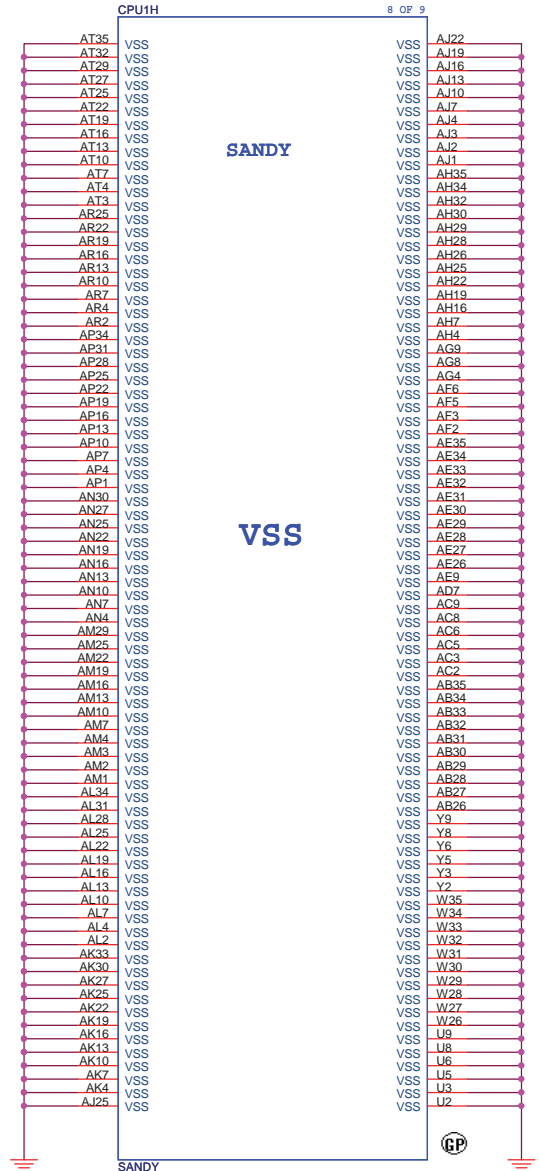

SANDY
62.10055.421
 2nd = 62.10040.771
 3rd = 63.10055.321

A00 0103 add 3rd foxconn CPU1 at XBuild batch run

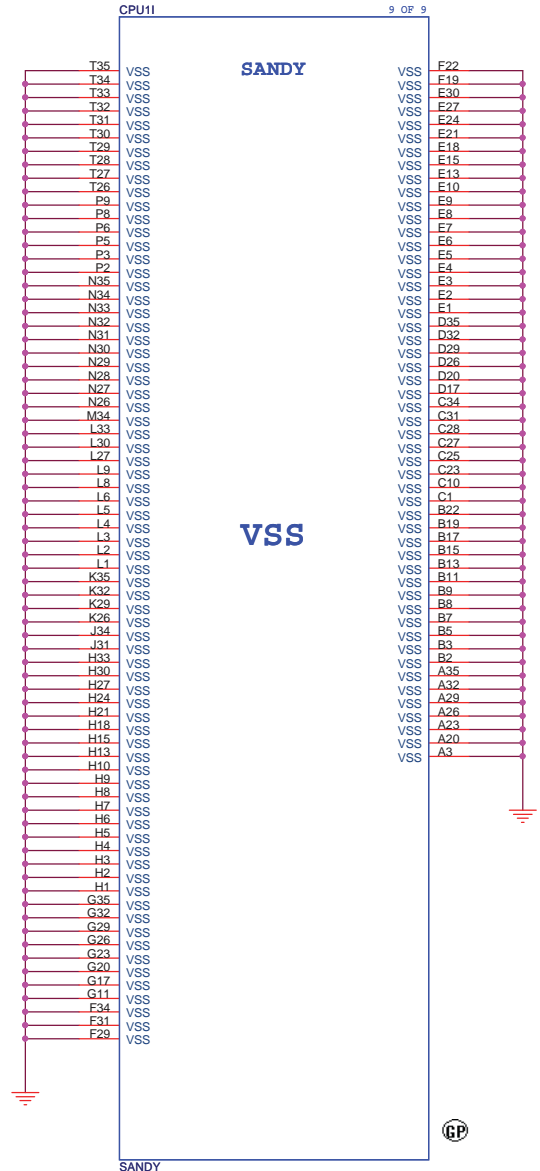

SANDY
62.10055.421
 2nd = 62.10040.771
 3rd = 62.10055.321

A00 0103 add 3rd foxconn CPU1 at XBuild batch run

<Variant Name>

Wistron Corporation
 21F, 88, Sec. 1, Hsin Tai Wu Rd., Hsichih,
 Taipei Hsien 221, Taiwan, R.O.C.

Title: **CPU (VSS)**

Size: A3	Document Number: QUEEN 15	Rev: A00
Date: Tuesday, January 04, 2011	Sheet: 10	of 108

(Blanking)

<Variant Name>



Title		
XDP		
Size	Document Number	Rev
A3	QUEEN 15	A00
Date:	Tuesday, January 04, 2011	Sheet 11 of 108

(Blanking)

<Core Design>



Title **Reserved**

Size A3	Document Number QUEEN 15	Rev A00
Date: Tuesday, January 04, 2011		Sheet 12 of 108

(Blanking)

<Core Design>

		Wistron Corporation 21F, 88, Sec. 1, Hsin Tai Wu Rd., Hsichih, Taipei Hsien 221, Taiwan, R.O.C.
Title		
Reserved		
Size	Document Number	Rev
A3	QUEEN 15	A00
Date: Tuesday, January 04, 2011	Sheet 13 of	108

SSID = MEMORY

0624 Modify: SWAP DM1 and DM2 location.

0617 Modify:
Joseph Change M_VREF_DQ_DIMM0, M_VREF_DQ_DIMM1, M_VREF_CA_DIMM0, M_VREF_CA_DIMM1 from net to power.

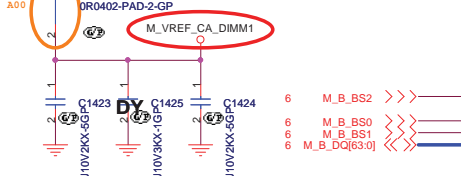

0617 Modify:
Joseph Change M_VREF_DQ_DIMM0, M_VREF_DQ_DIMM1, M_VREF_CA_DIMM0, M_VREF_CA_DIMM1 from net to power.

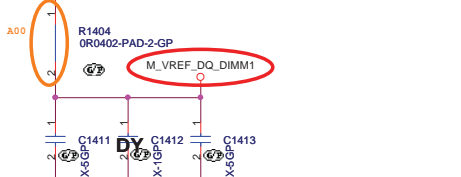

0707 Modify:
Change R1404, R1405 to 0ohm 0402 from short pad.

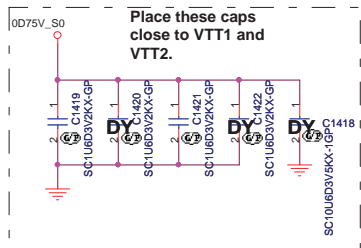

Place these caps close to VTT1 and VTT2.

M_B A0	98	A0
M_B A1	97	A1
M_B A2	96	A2
M_B A3	95	A3
M_B A4	92	A4
M_B A5	91	A5
M_B A6	86	A6
M_B A7	80	A7
M_B A8	89	A8
M_B A9	85	A9
M_B A10	107	A10/AP
M_B A11	84	A11
M_B A12	83	A12
M_B A13	119	A13
M_B A14	80	A14
M_B A15	78	A15
M_B BSA0	109	BA0
M_B BSA1	108	BA1
M_B DQ0	5	DO0
M_B DQ1	7	DO1
M_B DQ2	15	DO2
M_B DQ3	17	DO3
M_B DQ4	4	DO3
M_B DQ5	6	DO4
M_B DQ6	16	DO5
M_B DQ7	18	DO6
M_B DQ8	21	DO7
M_B DQ9	23	DO9
M_B DQ10	35	DO10
M_B DQ11	36	DO11
M_B DQ12	22	DO12
M_B DQ13	24	DO13
M_B DQ14	34	DO14
M_B DQ15	36	DO15
M_B DQ16	39	DO16
M_B DQ17	41	DO17
M_B DQ18	53	DO18
M_B DQ19	53	DO19
M_B DQ20	40	DO20
M_B DQ21	42	DO21
M_B DQ22	50	DO22
M_B DQ23	57	DO23
M_B DQ24	57	DO24
M_B DQ25	59	DO24
M_B DQ26	67	DO26
M_B DQ27	68	DO27
M_B DQ28	69	DO28
M_B DQ29	58	DO28
M_B DQ30	68	DO30
M_B DQ31	70	DO31
M_B DQ32	129	DO32
M_B DQ33	131	DO32
M_B DQ34	141	DO34
M_B DQ35	143	DO35
M_B DQ36	130	DO36
M_B DQ37	132	DO37
M_B DQ38	140	DO38
M_B DQ39	142	DO39
M_B DQ40	147	DO40
M_B DQ41	149	DO41
M_B DQ42	157	DO42
M_B DQ43	159	DO43
M_B DQ44	148	DO44
M_B DQ45	148	DO45
M_B DQ46	158	DO46
M_B DQ47	160	DO47
M_B DQ48	163	DO48
M_B DQ49	165	DO49
M_B DQ50	175	DO50
M_B DQ51	177	DO51
M_B DQ52	164	DO52
M_B DQ53	166	DO53
M_B DQ54	174	DO54
M_B DQ55	176	DO55
M_B DQ56	181	DO56
M_B DQ57	183	DO57
M_B DQ58	191	DO58
M_B DQ59	193	DO59
M_B DQ60	180	DO60
M_B DQ61	182	DO61
M_B DQ62	182	DO62
M_B DQ63	194	DO63
M_B DQS#0	10	DQS0#
M_B DQS#1	27	DQS1#
M_B DQS#2	45	DQS2#
M_B DQS#3	62	DQS3#
M_B DQS#4	135	DQS4#
M_B DQS#5	152	DQS5#
M_B DQS#6	169	DQS6#
M_B DQS#7	186	DQS7#
M_B DQS0	12	DQS0
M_B DQS1	29	DQS1
M_B DQS2	47	DQS2
M_B DQS3	64	DQS3
M_B DQS4	137	DQS4
M_B DQS5	154	DQS5
M_B DQS6	171	DQS6
M_B DQS7	188	DQS7
M_B DIM0_ODT0	116	ODT0
M_B DIM0_ODT1	120	ODT1
M_VREF_CA_DIMM1	126	VREF_CA
M_VREF_DQ_DIMM0	1	VREF_DQ
RESETP#	30	RESET#
VTT1	203	VTT1
VTT2	204	VTT2

M_B_DQS[7:0] 6
M_B_DQS[7:0] 6

6 M_B_DIM0_ODT0
6 M_B_DIM0_ODT1
M_VREF_CA_DIMM1
M_VREF_DQ_DIMM0
15,37 DDR3_DRAMRST#

0617 Modify:
Joseph Change M_VREF_DQ_DIMM0, M_VREF_DQ_DIMM1, M_VREF_CA_DIMM0, M_VREF_CA_DIMM1 from net to power.

H = 5.2mm
DDR3-204P-48-GP
62.10017.P61
2nd = 62.10017.N41
3rd = 62.10017.P41
4th = 62.10024.E21

NP1	71	NP1
NP2	72	NP2
RAS#	110	M_B_RAS# 6
WE#	113	M_B_WE# 6
CAS#	115	M_B_CAS# 6
CS0#	114	M_B_DIM0_CS#0 6
CS1#	121	M_B_DIM0_CS#1 6
CKE0	73	M_B_DIM0_CKE0 6
CKE1	74	M_B_DIM0_CKE1 6
CK0	101	M_B_DIM0_CLK_DDR0 6
CK0#	103	M_B_DIM0_CLK_DDR#0 6
CK1	102	M_B_DIM0_CLK_DDR1 6
CK1#	104	M_B_DIM0_CLK_DDR#1 6
DM0	11	
DM1	28	
DM2	46	
DM3	63	
DM4	136	
DM5	153	
DM6	170	
DM7	187	
SDA	200	PCH_SMBDATA 15,20,79,82
SCL	202	PCH_SMBCLK 15,20,79,82
EVENT#	198	TS#_DIMM0_1 15
VDDSPD	199	
SA0	197	SA0_DIM1
SA1	201	SA1_DIM1
NC#1	77	X
NC#2	122	X
NC#TEST	125	X
VDD1	75	VDD1
VDD2	76	VDD2
VDD3	81	VDD3
VDD4	82	VDD4
VDD5	87	VDD5
VDD6	88	VDD6
VDD7	93	VDD7
VDD8	94	VDD8
VDD9	99	VDD9
VDD10	100	VDD10
VDD11	105	VDD11
VDD12	106	VDD12
VDD13	111	VDD13
VDD14	112	VDD14
VDD15	117	VDD15
VDD16	119	VDD16
VDD17	123	VDD17
VDD18	124	VDD18
VSS	2	VSS
VSS	3	VSS
VSS	8	VSS
VSS	9	VSS
VSS	13	VSS
VSS	14	VSS
VSS	19	VSS
VSS	20	VSS
VSS	25	VSS
VSS	26	VSS
VSS	31	VSS
VSS	32	VSS
VSS	37	VSS
VSS	38	VSS
VSS	43	VSS
VSS	44	VSS
VSS	48	VSS
VSS	49	VSS
VSS	54	VSS
VSS	55	VSS
VSS	58	VSS
VSS	60	VSS
VSS	61	VSS
VSS	65	VSS
VSS	66	VSS
VSS	71	VSS
VSS	72	VSS
VSS	127	VSS
VSS	128	VSS
VSS	133	VSS
VSS	134	VSS
VSS	138	VSS
VSS	139	VSS
VSS	144	VSS
VSS	145	VSS
VSS	150	VSS
VSS	151	VSS
VSS	155	VSS
VSS	156	VSS
VSS	162	VSS
VSS	167	VSS
VSS	168	VSS
VSS	172	VSS
VSS	173	VSS
VSS	178	VSS
VSS	179	VSS
VSS	184	VSS
VSS	185	VSS
VSS	189	VSS
VSS	190	VSS
VSS	195	VSS
VSS	196	VSS
VSS	205	VSS
VSS	206	VSS

1110 X02 Modify:
DM2 1st change to 62.10017.P61; 2nd change to 62.10017.N41 on ST stage from MR updated connector list.

PART NUMBER	Height	TYPE
62.10017.P61	5.2mm	REVERSED
62.10017.N41(2nd)	5.2mm	REVERSED
62.10017.P41(3rd)	5.2mm	REVERSED
62.10024.E21(4th)	5.2mm	REVERSED

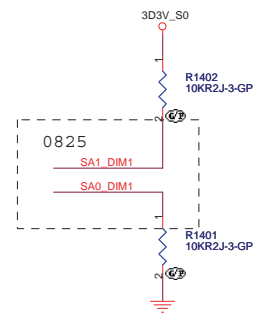

Note:
If SA0_DIM0 = 0, SA1_DIM0 = 0
SO-DIMMA SPD Address is 0xA0
SO-DIMMA TS Address is 0x30

If SA0_DIM0 = 1, SA1_DIM0 = 0
SO-DIMMA SPD Address is 0xA2
SO-DIMMA TS Address is 0x32

Thermal EVENT

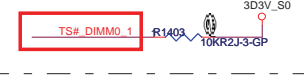

SODIMM A DECOUPLING

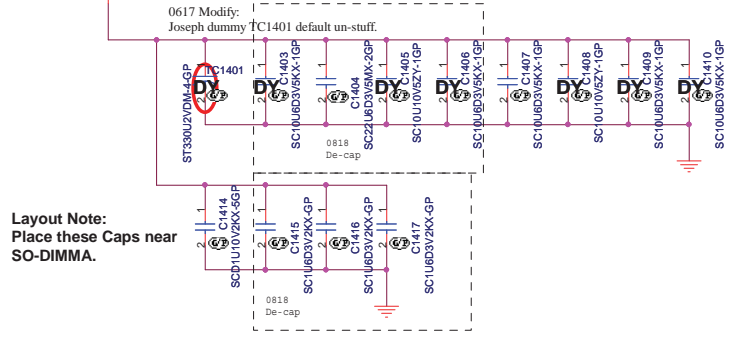

Layout Note:
Place these Caps near SO-DIMMA.

<Variant Name>

DELL Wistron Corporation
21F, 88, Sec. 1, Hsin Tai Hsi Rd., Hsichih, Taipei Hsien 221, Taiwan, R.O.C.

Title: **DDR3-SODIMM2**

Size Custom: **QUEEN 15**

Date: **Thursday, January 04, 2011**

Rev: **A00**

Sheet 14 of 108

(Blanking)

<Core Design>



Title **Reserved**

Size A3	Document Number QUEEN 15	Rev A00
------------	------------------------------------	-------------------

Date: Tuesday, January 04, 2011 Sheet 16 of 108

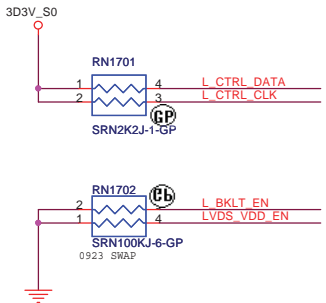

L_DDC_DATA(PAGE17):
This signal is on the LVDS interface.
This signal needs to be left NC if eDP is used for the local flat panel display

Place near PCH

Impedance: 90 ohm

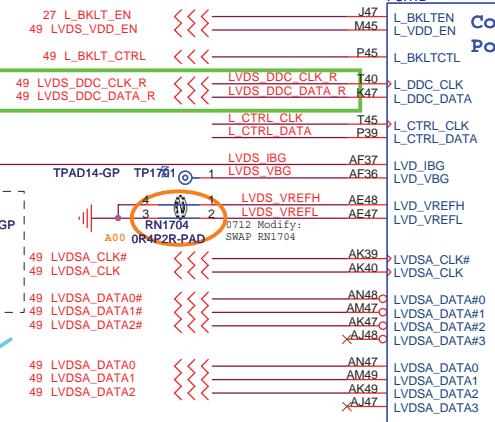

0617 Modify:
Joseph Removed LVDSB related net for single LVDS channel base on Dell updated spec.

0917 X01 Modify:
Add R1703-R1705 on RGB signal and reserved EC1701-EC1703 0.1u from EMC Neo suggestion.

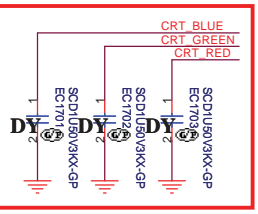
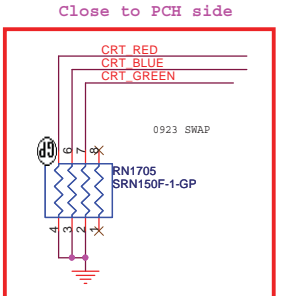

Notes:
1K 0.5% 0402.
CHIP RES 1K D 1/16W 0402

Cougar Point

Digital Display Interface

LVDS

CRT

COUGAR-GP-U2-NF

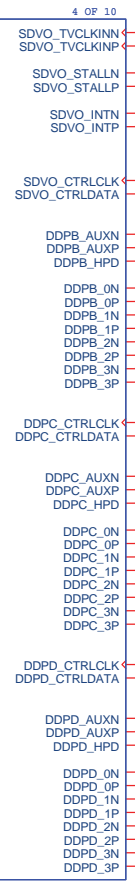

4 OF 10

P38

0804 Remove HDMI from PCH.

Configuration Pin Mapping for DDI Ports (Sheet 1 of 2)

PORT	DDI PCH Pin Names	SDVO Mapping	Display Port Mapping	HDMI/DVI Mapping
PORT-B	DDPB_[0]P	SDVO_RED	DDPB_[0]P	TMDSB_DATA2
	DDPB_[0]N	SDVO_RED#	DDPB_[0]N	TMDSB_DATA2#
	DDPB_[1]P	SDVO_GREEN	DDPB_[1]P	TMDSB_DATA1
	DDPB_[1]N	SDVO_GREEN#	DDPB_[1]N	TMDSB_DATA1#
	DDPB_[2]P	SDVO_BLUE	DDPB_[2]P	TMDSB_DATA0
	DDPB_[2]N	SDVO_BLUE#	DDPB_[2]N	TMDSB_DATA0#
	DDPB_[3]P	SDVO_CLK	DDPB_[3]P	TMDSB_CLK
	DDPB_[3]N	SDVO_CLK#	DDPB_[3]N	TMDSB_CLK#
	DDPB_AUXP	NA	DDPB_AUXP	NA
	DDPB_AUXN	NA	DDPB_AUXN	NA
	SDVO_CTRLCLK	SDVO_CTRLCLK	NA	HDMIIB_CTRLCLK
	SDVO_CTRLDATA	SDVO_CTRLDATA	NA	HDMIIB_CTRLDATA

<Variant Name>



SSID = PCH

0709 Modify:
Removed INT_PIRQ# on RN1801 pin1.

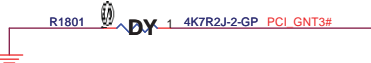
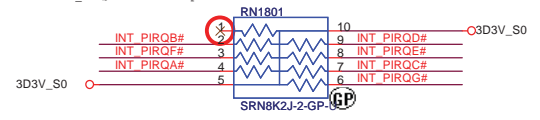

A16 swap override Strap/Top-Block Swap Override jumper	
PCI_GNT#3	Low = A16 swap override/Top-Block Swap Override enabled High = Default

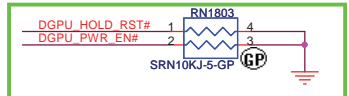

GNT1#/GPIO51	SATA1GP/GPIO19	BOOT BIOS Location
0	0	LPC
0	1	Reserved
1	0	Reserved
1	1	SPI (Default)

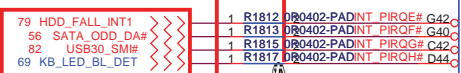
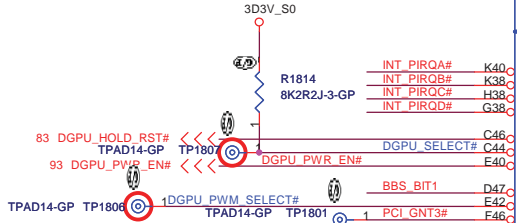

0709 Modify:
Add R1817 0ohm and connect to KB_LED_BL_DET. (5V Tolerance High Active)

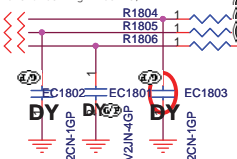

0617 Modify:
Joseph Remove PLT_RST AND gate logic IC U1801/C1802.

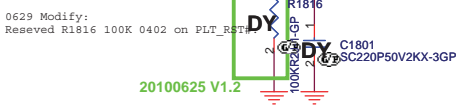

KBC CLK EMI

0908 X01 Modify:
Add R1818 10K PL on FFS INT2 R (GPIO14)

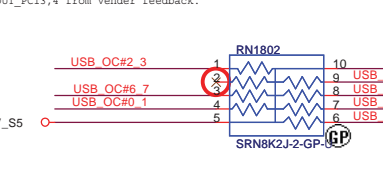
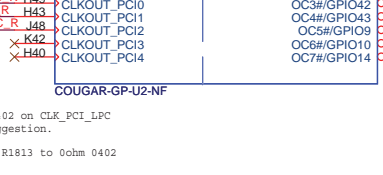
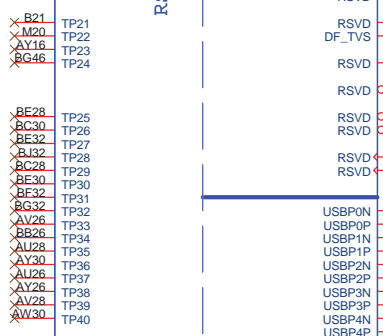
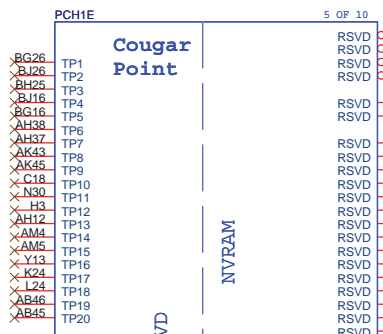
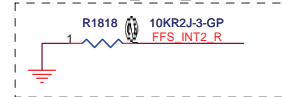

0719 Modify:
DP_TVS (NV_CLE) connect PROC_SELECT# (H_SNB_IVB#) with R1808 2.2K(05% pull up resistor to PCH_VCCPND rail and a R1809 1K(05% series resistor base on Intel feedback.

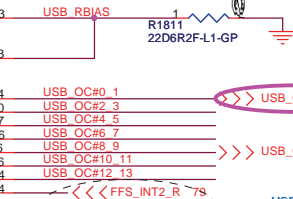
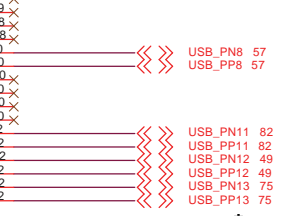
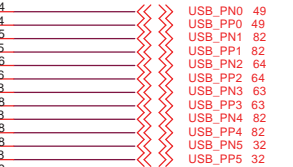
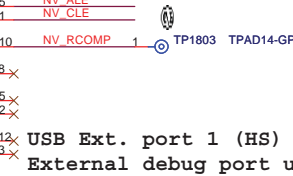
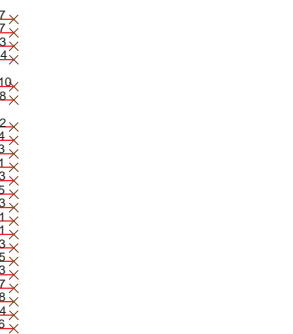

0908
OC[3:0]# for Device 29 (Ports 0-7)
OC[7:4]# for Device 26 (Ports 8-13)

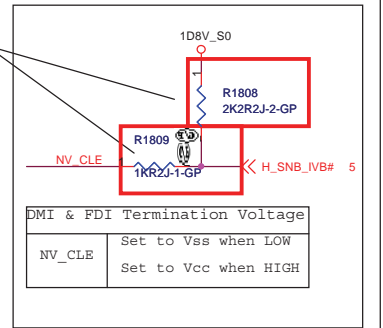

NV_CLE	Set to Vss when LOW
NV_ALE	Set to Vcc when HIGH

Danbury Technology:
Disabled when Low.
Enable when High.

USB Ext. port 1 (HS) External debug port use on Huron river platform USB Table

Pair	Device
0	Touch Panel / 3G SIM
1	USB Ext. port 1 (HS)
2	Fingerprint
3	BLUETOOTH
4	Mini Card2 (WWAN)
5	CARD READER
6	X
7	X
8	USB Ext. port 4 / E-SATA / USB CHARGER
9	USB Ext. port 2
10	USB Ext. port 3
11	Mini Card1 (WLAN)
12	CAMERA
13	Express Card

1120 X02 Modify:
Reserved USB_OC#_1 connect from PCH GPIO59.

USB 2.0 Overcurrent Pin Default Usage

Pin	Default Port Mapping	Pin	Default Port Mapping
OC0#	Port 0, Port 1	OC4#	Port 8, Port 9
OC1#	Port 2, Port 3	OC5#	Port 10, Port 11
OC2#	Port 4, Port 5	OC6#	Port 12, Port 13
OC3#	Port 6, Port 7	OC7#	Not Used



SSID = PCH



Signal Routing Guideline:
 DMI_ZCOMP keep W=4 mils and routing length less than 500 mils.
 DMI_IRCOMP keep W=4 mils and routing length less than 500 mils.

Deep S4/S5 Supported Deep S4/S5 Not Supported

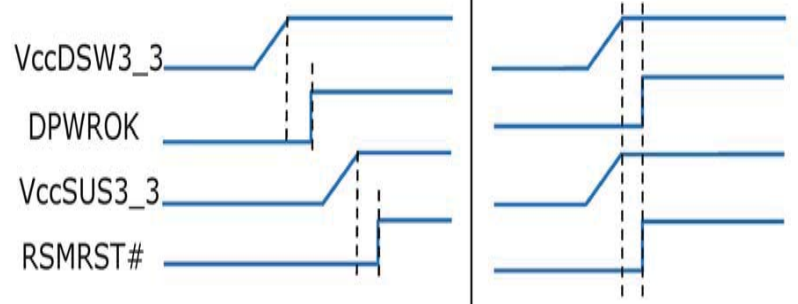

- For platforms not supporting Deep S4/S5
- 1.VccSUS3_3 and VccDSW3_3 will rise at the same time (connected on board)
 - 2.DPWROK and RSMRST# will rise at the same time (connected on board)
 - 3.SLP_SUS# and SUSACK# are left as 'no connect';
 - 4.SUSWRN# used as SUSPWRDNACK/GPIO30

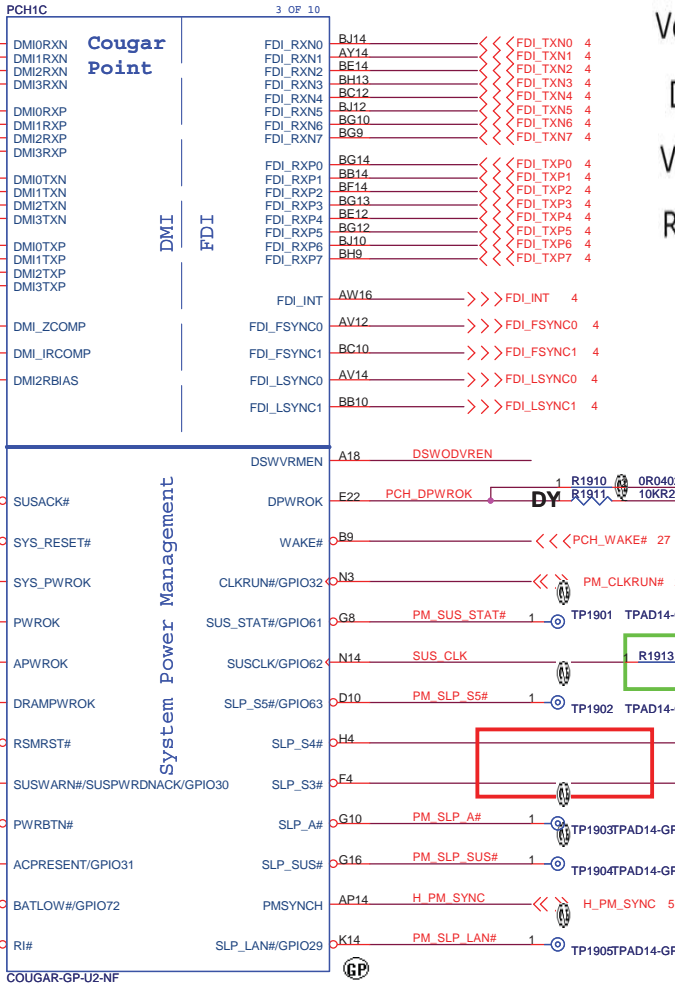
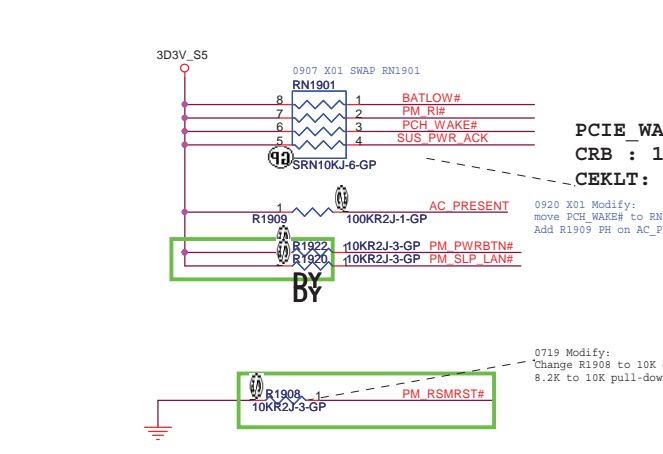
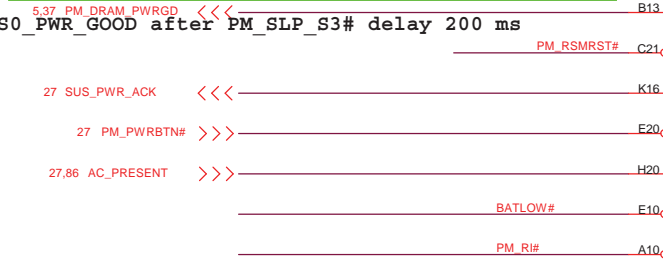
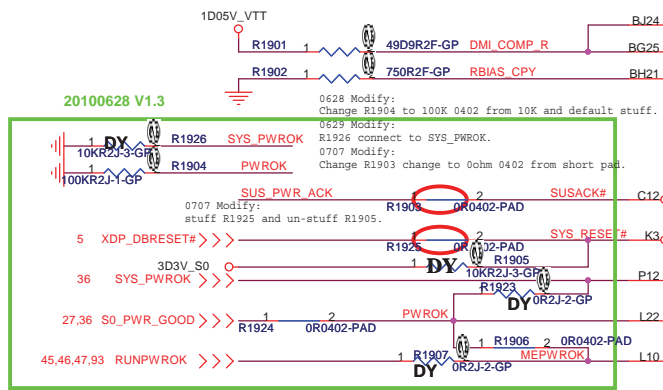

0621 Modify:
 Joseph removed Q1901/R1909/R1916 3V_5V_POK and PM_RSMRST# related control circuit.

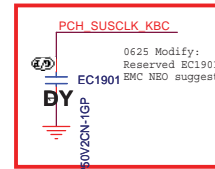

DSWODVREN - On Die DSW VR Enable	
HIGH	Enabled (DEFAULT)
LOW	Disabled



<Variant Name>

21F, 88, Sec.1, Hsin Tai Wu Rd., Hsichih, Taipei Hsien 221, Taiwan, R.O.C.

Title	PCH (DM I/FD/PM)	
Size	Document Number	Rev
A3	QUEEN 15	A00
Date:	Tuesday, January 04, 2011	Sheet 19 of 108

SSID = PCH

1112 X02 Modify:
Dell required us to disable PCIE port of WWAN slot
,If PCIE port 1 is disabled, it will cause all PCIE port
disabled,so change WWAN to PCIE port 3 from port1
at ST stage.

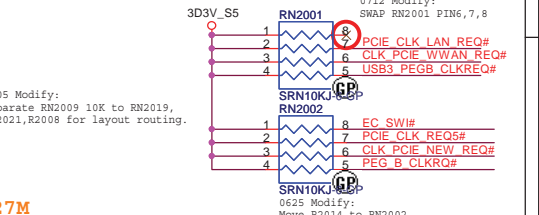
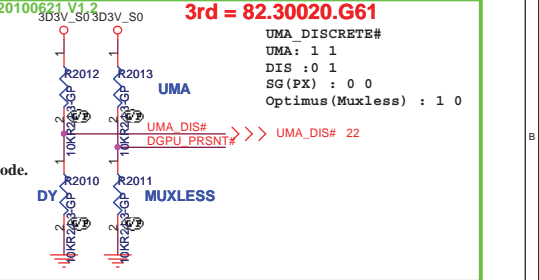
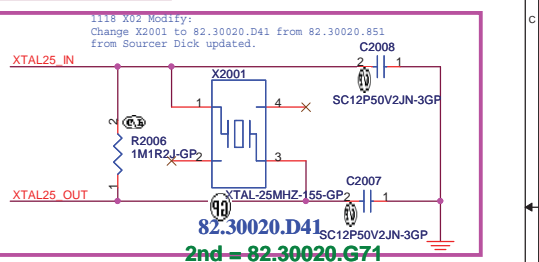
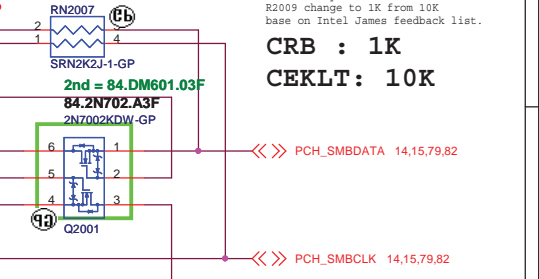
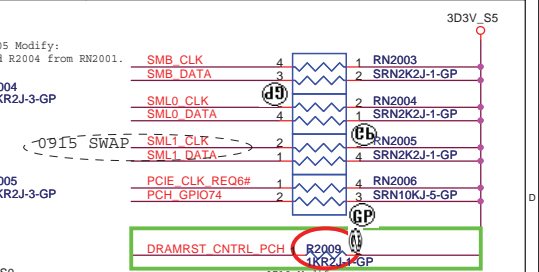
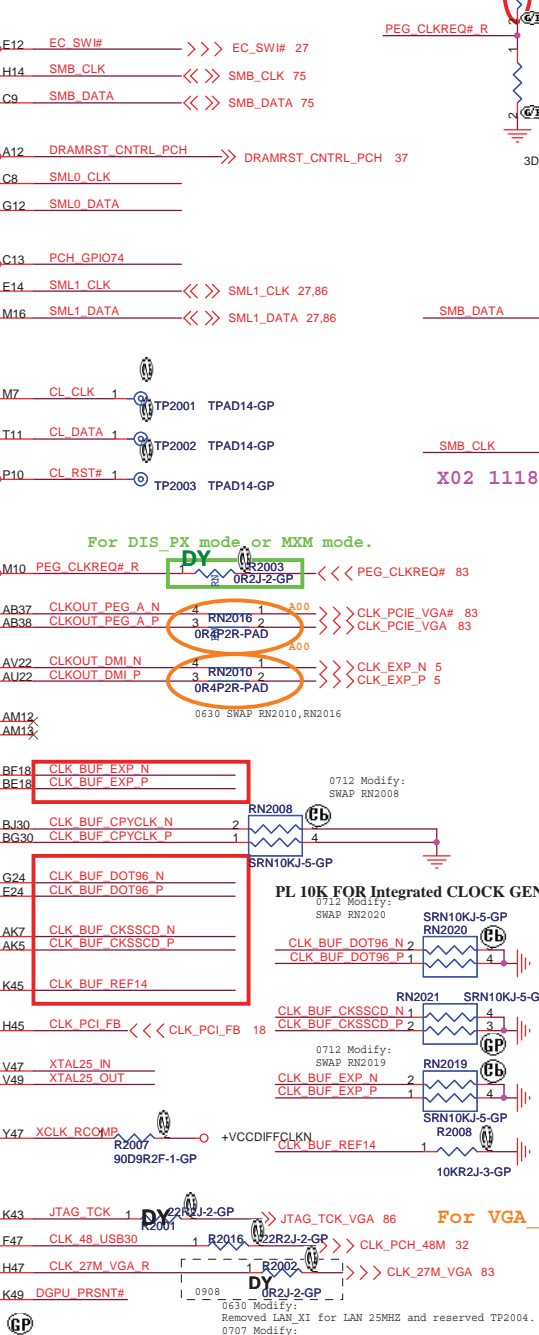
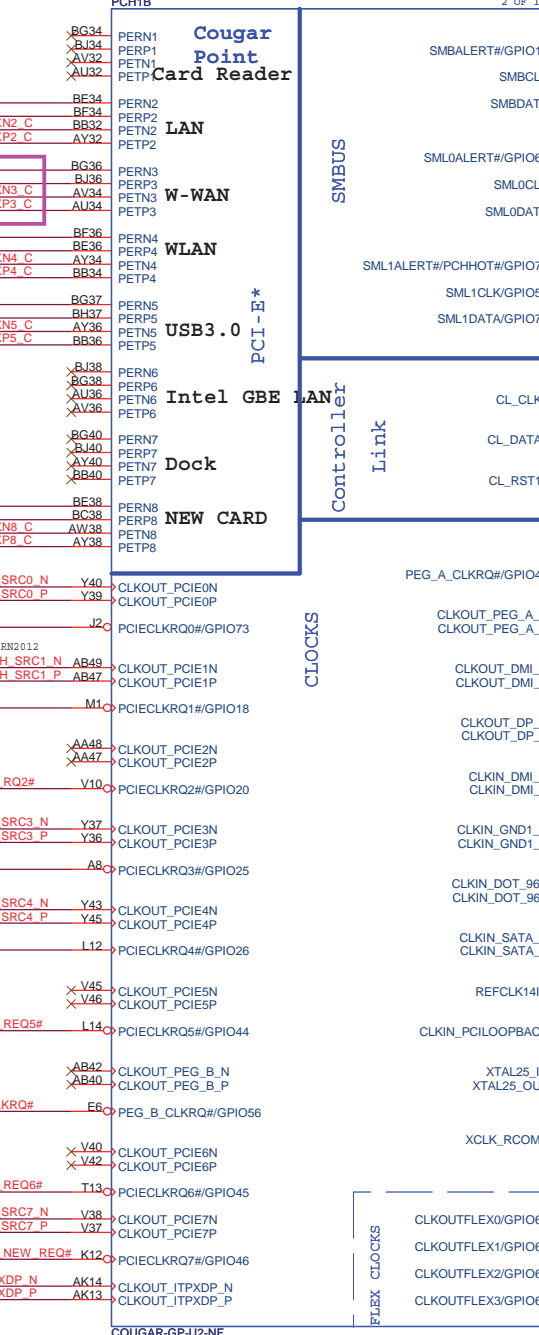
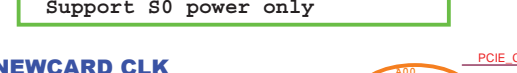
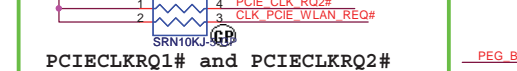
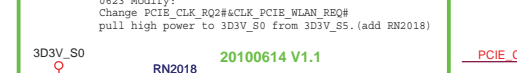
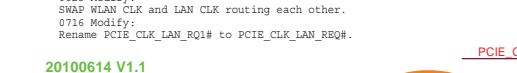
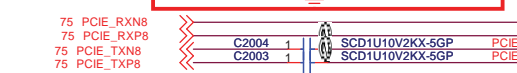
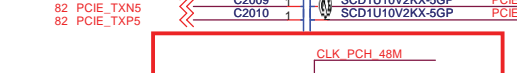
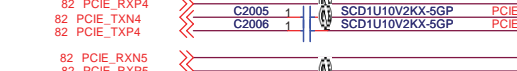
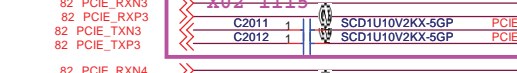
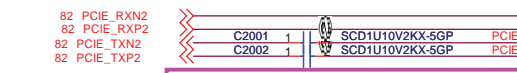

0630 Modify: Removed XDP CLOCK and reserved TP2005, TP2006.
0913 X01 Modify: Reserved EC2004, EC2005 on CLK_PCH_NEW# & CLK_PCIE_NEW# for EMC suggestion.
iV Prioritize 27/14/24/48/25-MHz FLEX on FLEX1 and FLEX3
iV Do not configure 27/14/24/48/25-MHz FLEX clock on FLEX0 and FLEX2
if more than 2 PCI clocks + PCI loopback are routed.

DELL Wistron Corporation
21F, 88, Sec. 1, Hsin Tai Wu Rd., Hsichih, Taipei Hsien 221, Taiwan, R.O.C.

Title: **PCH (PCI-E/SMBUS/CLOCK/CL)**

Size A3 Document Number: **QUEEN 15** Rev: **A00**

Date: Tuesday, January 04, 2011 Sheet 20 of 108

SSID = PCH

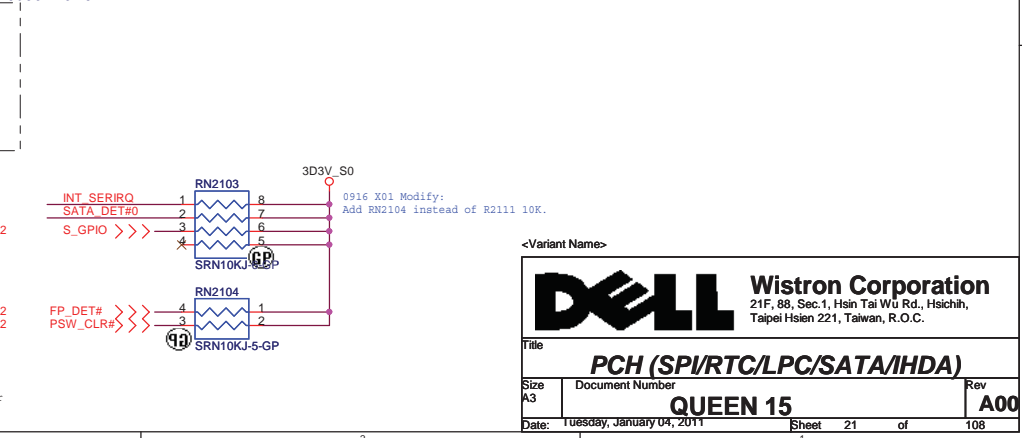
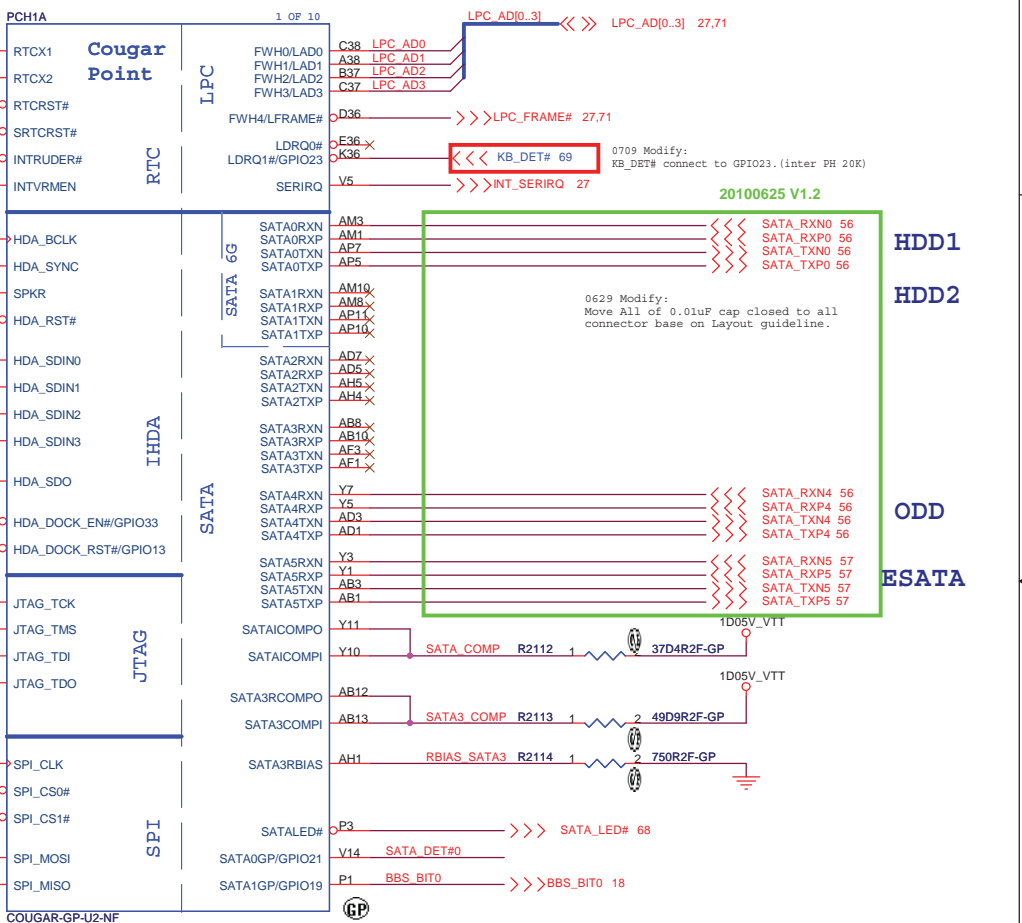
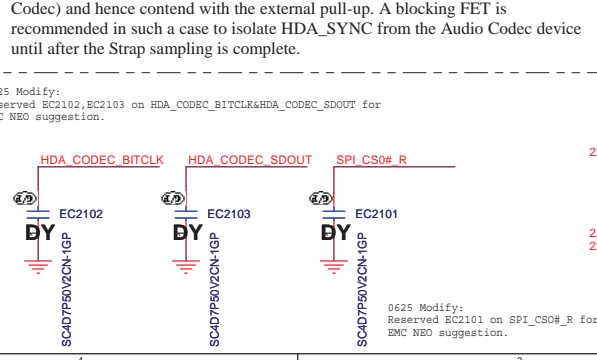
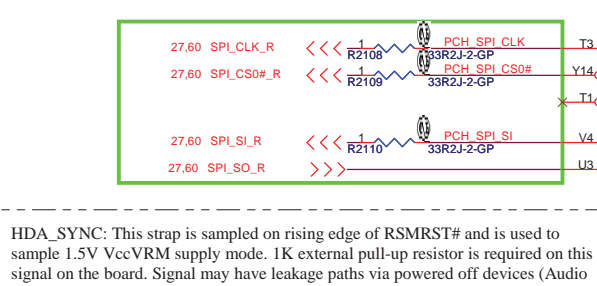
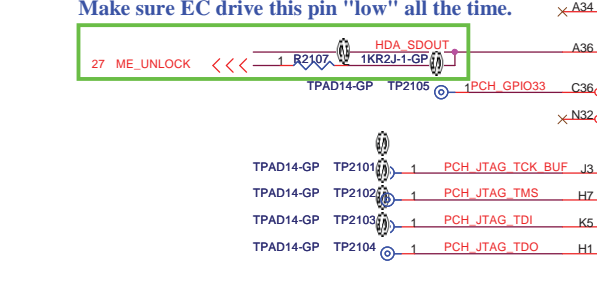
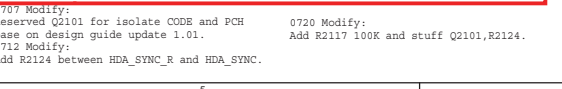
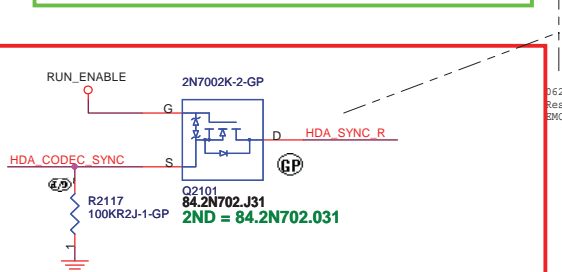
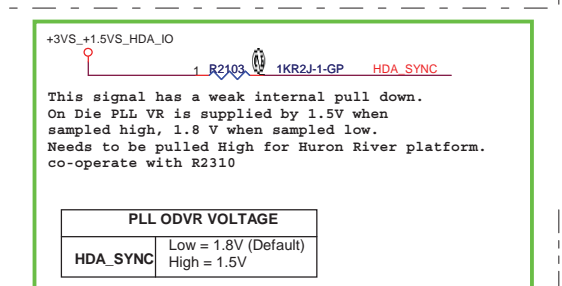
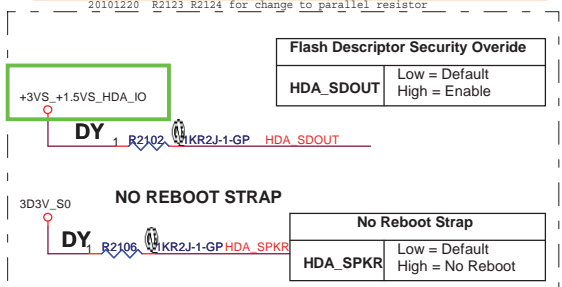
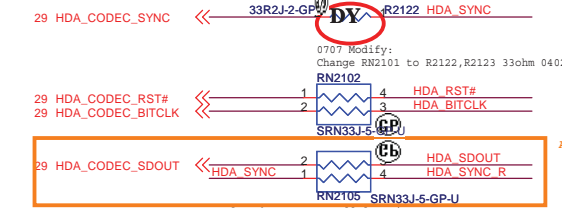
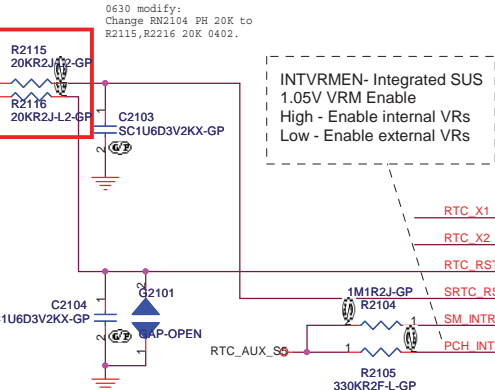
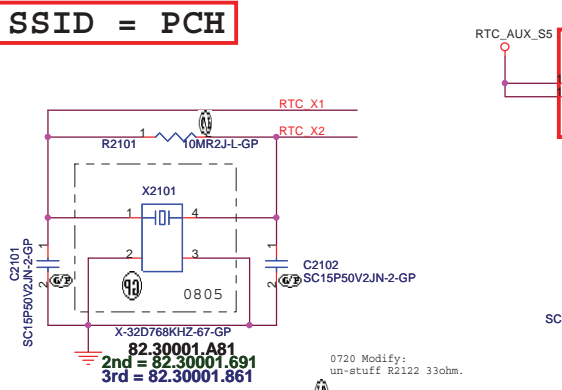

Wistron Corporation
21F, 88, Sec. 1, Hsin Tai Wu Rd., Hsichih, Taipei Hsien 221, Taiwan, R.O.C.

DELL

File: **PCH (SPI/RTC/LPC/SATA/IHDA)**

Size: A3, Document Number: **QUEEN 15**, Rev: **A00**

Date: Tuesday, January 04, 2011, Sheet 21 of 108

SSID = PCH

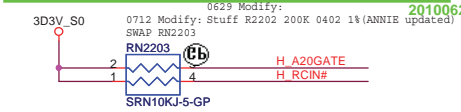
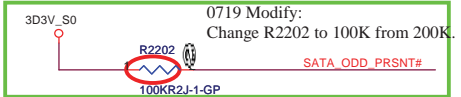

0719 Modify:
Change R2202 to 100K from 200K.

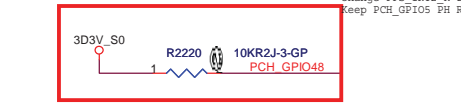

0701 Modify:
Separate PCH_TEMP_ALERT# from RN2201 to R2222 10K base on layout limitation.

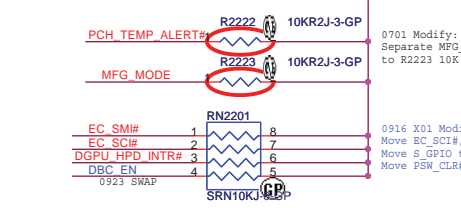

0701 Modify:
Separate MFG_MODE from RN2202 to R2223 10K base on layout limitation.

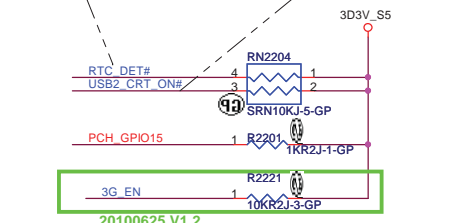

0629 Modify:
Add R2221 10K 0402 on PCH_GPIO24 (ANNIE updated)

Note:
For PCH debug with XDP, need to NO STUFF R2218

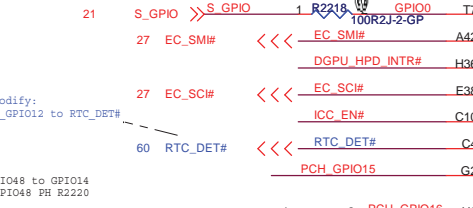

1120 X02 Modify:
Rename PCH_GPIO12 to RTC_DET# on GPIO12.

0720 Modify:
Removed DBC_EN on GPIO22.

0709 Modify:
Rename PCH_GPIO22 to DBC_EN. Rename PCH_GPIO24 to 3G_EN.

0916 X01 Modify:
Move EC_SCI#, DBC_EN to RN2201. Move S_GPIO to RN2103. Move PSW_CLR# to RN2104.

1118 X02 Modify:
Rename USB3_PWR_ON to PCH_GPIO57. Reserved USB2_CRT_ON# to control U6102 USB power switch from PCH GPIO57.

0714 Modify:
Add TP2206-TP2209 on PCH NCTF pin.

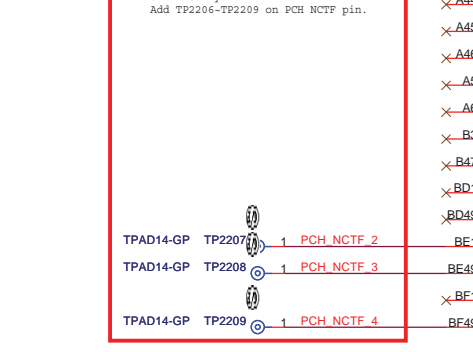

0705 Modify:
Removed R2214-R2217 10K 0402 on VRAM_SIZE1&2.

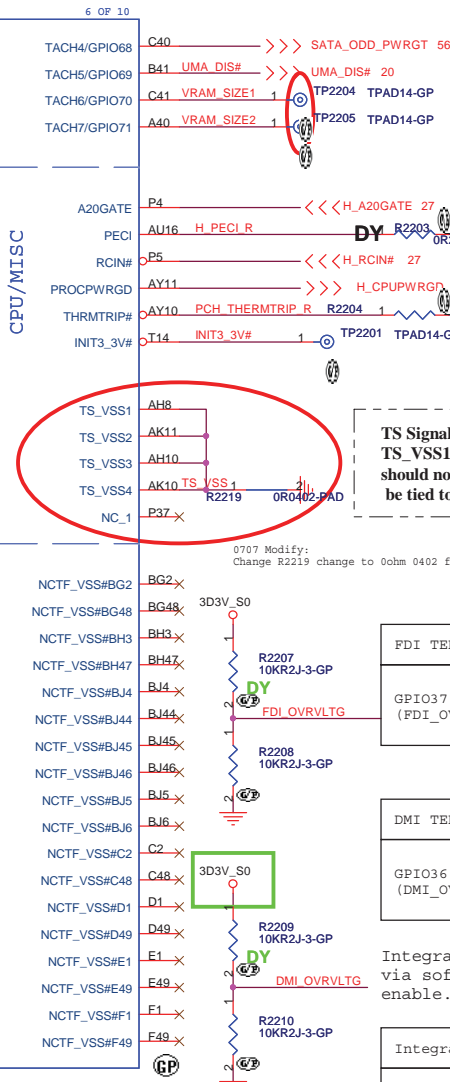
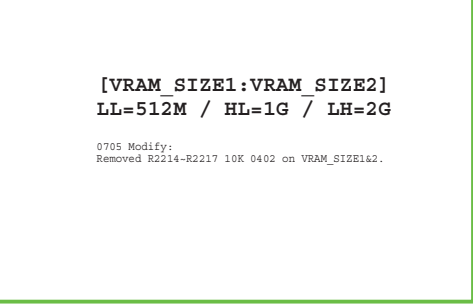

	GSENSOR_ST	GSENSOR_ADI
R2205	DY	10K
R2206	100K	DY

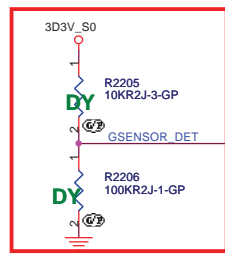

0625 Modify:
Change PL 100K 0402 from PH on GFX_CRB_DET.

TS Signal Disable Guideline:
TS_VSS1, TS_VSS2, TS_VSS3 and TS_VSS4 should not float on the motherboard. They should be tied to GND directly.

FDI TERMINATION VOLTAGE OVERRIDE	
GPIO37 (FDI_OVRVLTG)	LOW - Tx, Rx terminated to same voltage (DC Coupling Model DEFAULT)

DMI TERMINATION VOLTAGE OVERRIDE	
GPIO36 (DMI_OVRVLTG)	LOW - Tx, Rx terminated to same voltage (DC Coupling Model DEFAULT)

Integrated Clock Enable functionality is achieved via soft-strap. The default is integrated clock enable.

Integrated Clock Chip Enable	
ICC_EN#	HIGH (R2211 DY) - DISABLED [DEFAULT]
	LOW (R2211) - ENABLED

GPIO8 has a weak [20K] internal pull up. Integrated Clock Enable functionality is achieved via soft-strap. The default is integrated clock enable.

PLL ON DIE VR ENABLE

NOTE: This signal has a weak internal pull-up 20K

ENABLED -- HIGH (R2212 UNSTUFFED) DEFAULT

DISABLED -- LOW (R2212 STUFFED)

<Variant Name>

21F, 88, Sec. 1, Hsin Tai Wu Rd., Hsichih, Taipei Hsien 221, Taiwan, R.O.C.

Title: **PCH (GPIO/CPU)**

Size A3 Document Number: **QUEEN 15** Rev: **A00**

Date: Tuesday, January 04, 2011 Sheet 22 of 108

SSID = PCH 6A

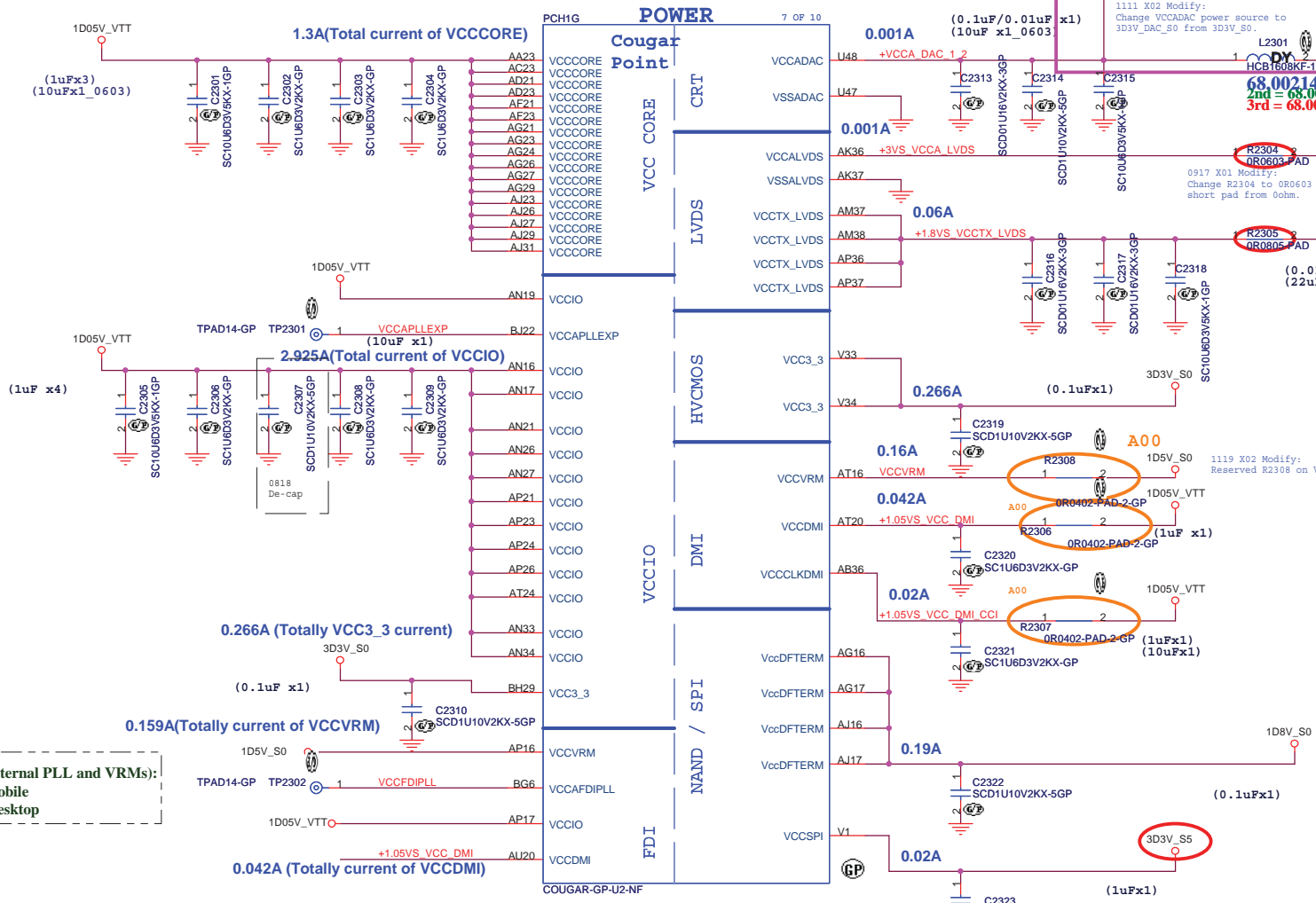

VCCVRM (Internal PLL and VRMs):
A.1.5V for Mobile
B.1.8 V for Desktop

1122 X02 Modify:
Removed U2302 LDO for VCCVRM.

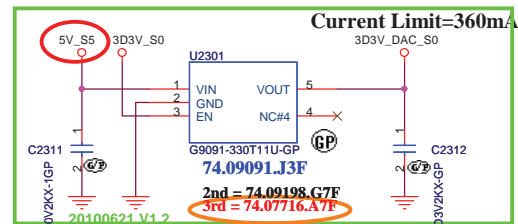

A00 1229 add 3rd Richtek(74.09198.G7F) on U2301 at XBuild batch run config

Voltage Rail	Voltage	Iccmax
V_PROC_IO	1.05	0.001
V5REF	5	0.001
V5REF_Sus	5	0.001
Vcc3_3	3.3	0.266
VccADAC3	3.3	0.001
VccADPLLA	1.05	0.08
VccADPLLB	1.05	0.08
VccCore	1.05	1.3
VccDMI	1.1	0.042
VccIO3	1.05	2.925
VccASW	1.05	1.01
VccSPI	3.3	0.02
VccDSW3_3	3.3	0.002
VccDFTERM	1.8	0.19
VccRTC	3.3	6u
VccSus3_3	3.3	0.097
VccSusHDA	3.3	0.01
VccVRM	1.5	0.16
VccClkDMI	1.05	0.02
VccSSC	1.05	0.095
VccDIFFCLKN	1.05	0.055
VccALVDS	3.3	0.001
VccTX_LVDS3	1.8	0.06

Refer to NPCE795 shared SPI flash architecture

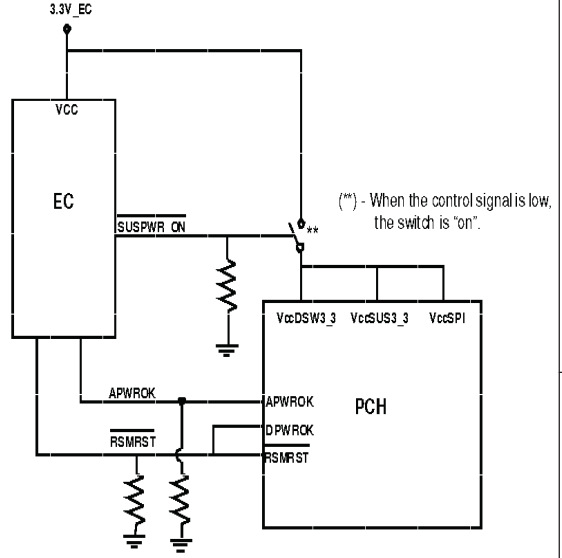

<Variant Name>

Wistron Corporation
21F, 88, Sec.1, Hsin Tai Wu Rd., Hsichih, Taipei Hsien 221, Taiwan, R.O.C.

Title: **PCH (POWER1)**

Size A3 Document Number: **QUEEN 15** Rev: **A00**

Date: Tuesday, January 04, 2011 Sheet 23 of 108

SSID = PCH

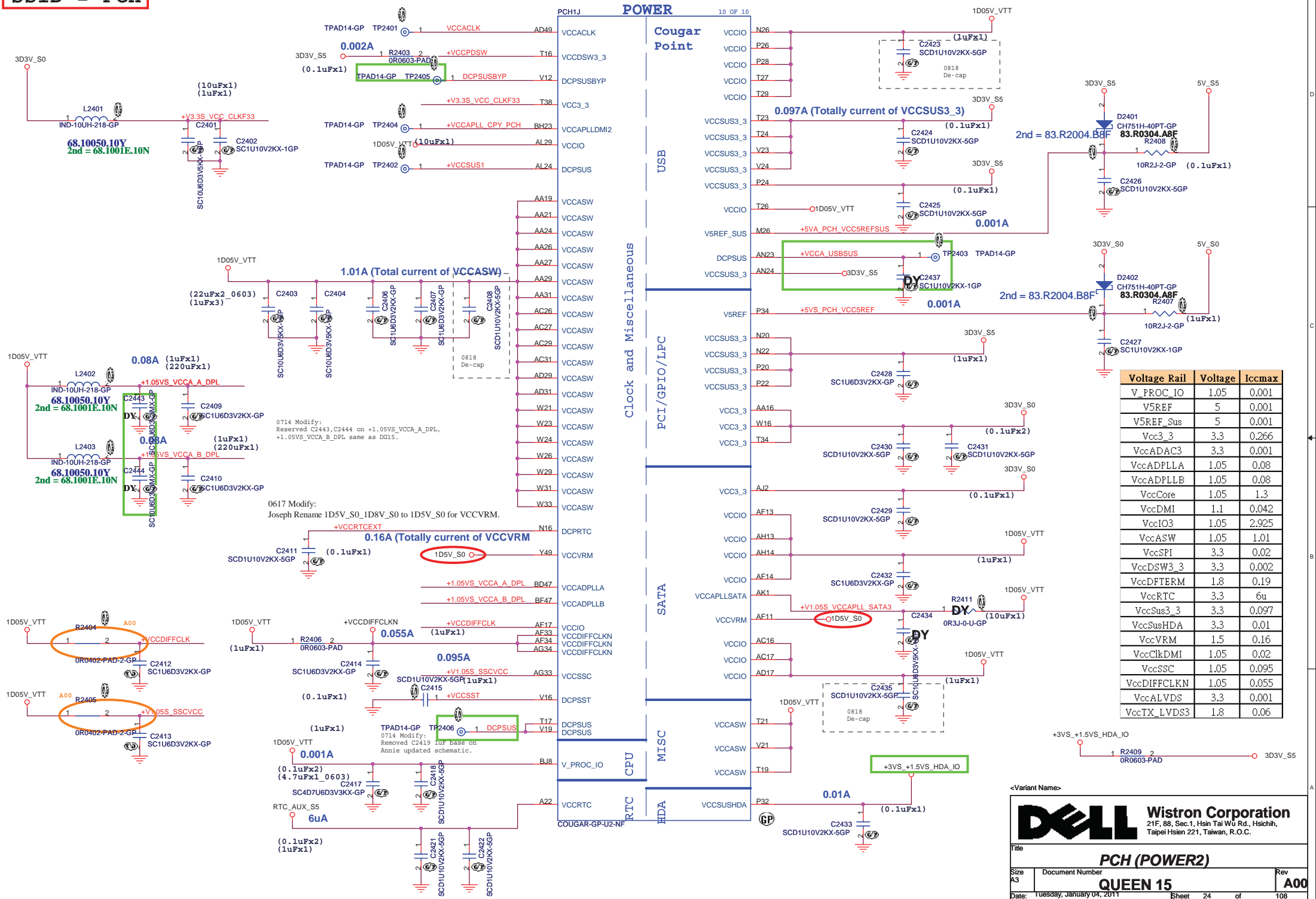

Voltage Rail	Voltage	Iccmax
V_PROC_IO	1.05	0.001
V5REF	5	0.001
V5REF_Sus	5	0.001
Vcc3_3	3.3	0.266
VccADAC3	3.3	0.001
VccADPLLA	1.05	0.08
VccADPLLB	1.05	0.08
VccCore	1.05	1.3
VccDMI	1.1	0.042
VccIO3	1.05	2.925
VccASW	1.05	1.01
VccSPI	3.3	0.02
VccDSW3_3	3.3	0.002
VccDFTERM	1.8	0.19
VccRTC	3.3	6u
VccSus3_3	3.3	0.097
VccSusHDA	3.3	0.01
VccVRM	1.5	0.16
VccClkDMI	1.05	0.02
VccSSC	1.05	0.095
VccDIFFCLKN	1.05	0.055
VccALVDS	3.3	0.001
VccTX_LVDS3	1.8	0.06

DELL Wistron Corporation
 21F, 88, Sec. 1, Hsin Tai Wu Rd., Hsichih,
 Taipei Hsien 221, Taiwan, R.O.C.

Title: **PCH (POWER2)**

Size: A3 Document Number: **QUEEN 15** Rev: **A00**

Date: Tuesday, January 04, 2011 Sheet 24 of 108

SSID = PCH

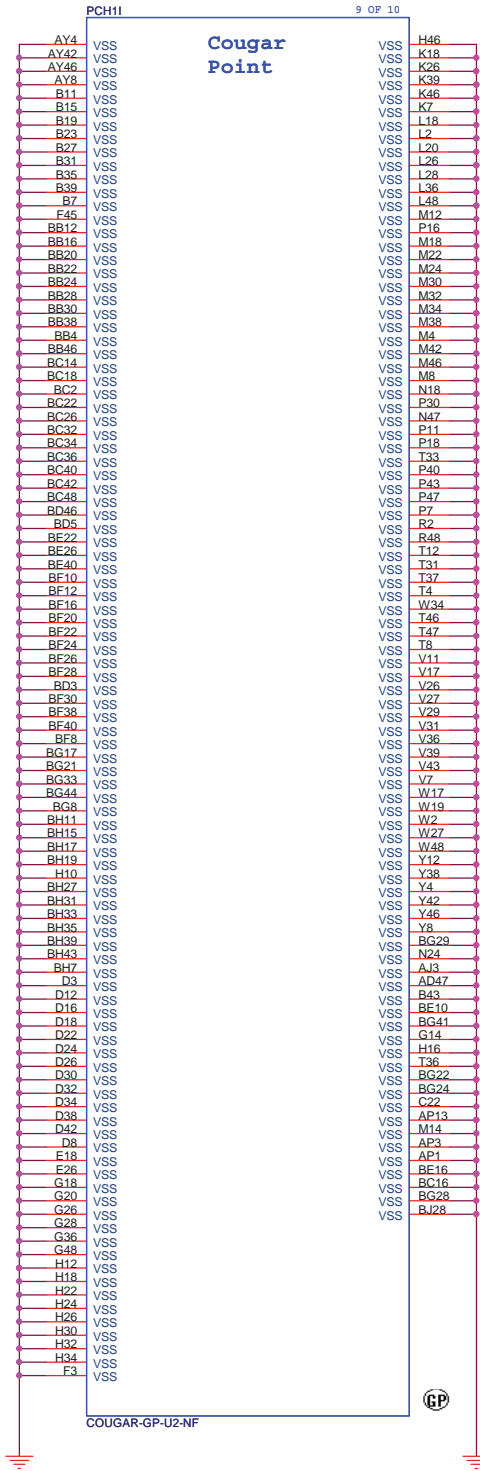
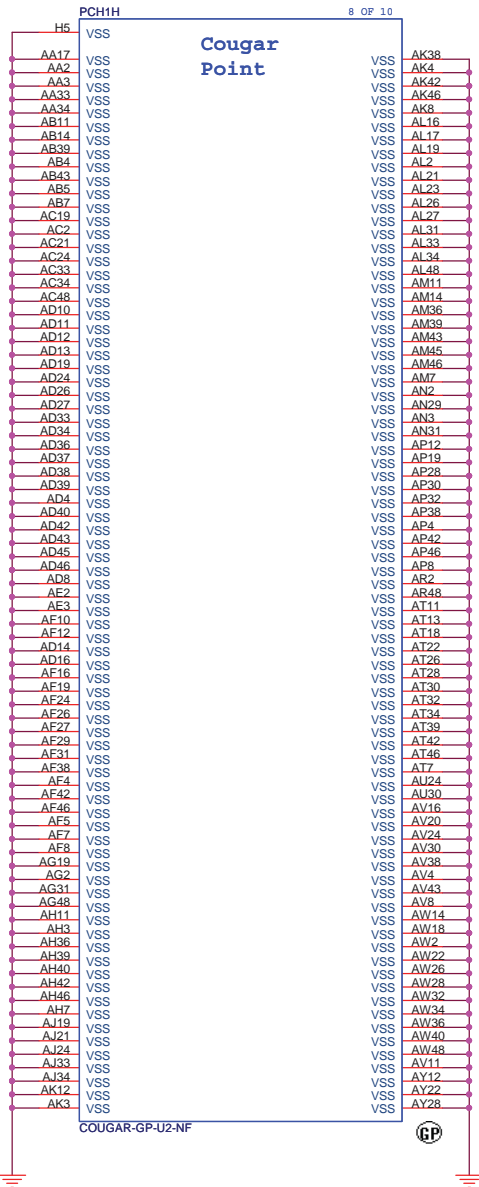

<Variant Name>

DELL Wistron Corporation
21F, 88, Sec. 1, Hsin Tai Wu Rd., Hsichih, Taipei Hsien 221, Taiwan, R.O.C.

Title: **PCH (VSS)**

Size A3	Document Number	Rev
	QUEEN 15	A00

Date: Tuesday, January 04, 2011 Sheet 25 of 108

(Blanking)

<Variant Name>



Wistron Corporation
21F, 88, Sec. 1, Hsin Tai Wu Rd., Hsichih,
Taipei Hsien 221, Taiwan, R.O.C.

Title		
Reserved		
Size	Document Number	Rev
A3	QUEEN 15	A00
Date:	Tuesday, January 04, 2011	Sheet 26 of 108

SSID = KBC

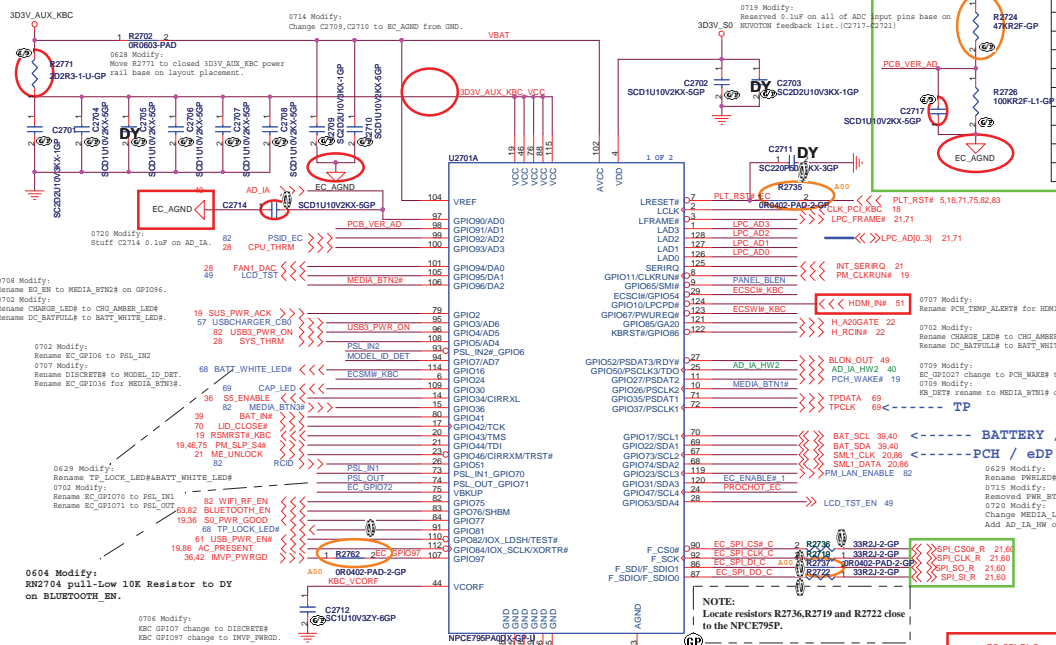

PCB VERSION A/D(PIN#)	PULL-LOW RESISTOR	PULL-HIGH RESISTOR	VOLTAGE
X00	100.0K	10.0K	3.0V
X01	100.0K	20.0K	2.75V
X02	100.0K	33.0K	2.48V
A00	100.0K	47.0K	2.24V
Reserved	100.0K	64.9K	2.0V
Reserved	100.0K	76.8	1.87V
Reserved	100.0K	100.0K	1.65V
Reserved	100.0K	143.0K	1.358V
Reserved	100.0K	174.0K	1.204V
Reserved	100.0K	215.0K	1.048V

MODEL_ID_DET(GPIO#)	PULL-LOW RESISTOR	PULL-HIGH RESISTOR	VOLTAGE
DQ15_UMA	100.0K	10.0K	3.0V
DQ15_ATA	100.0K	20.0K	2.75V
DQ15_NVidia	100.0K	33.0K	2.48V
DN15_UMA	100.0K	47.0K	2.24V
DN15_ATA	100.0K	64.9K	2.0V
DQ13_ATA	100.0K	76.8K	1.87V
DQ13_UMA	100.0K	100.0K	1.65V
DN13_UMA	100.0K	143.0K	1.358V
DN13_ATA	100.0K	174.0K	1.204V
DQ15_Ventura	100.0K	215.0K	1.048V

NOTES:
The NPCE795P GPIO/PWM outputs that are connected to LEDs have high drive buffers (20mA) and can be connected directly to the LEDs.

Notes:
The total SPI interface signal between EC and PCH can't exceed 6500mil. The mismatch between SPI signal must be within 500mil

ROSA Multi GPIO setting

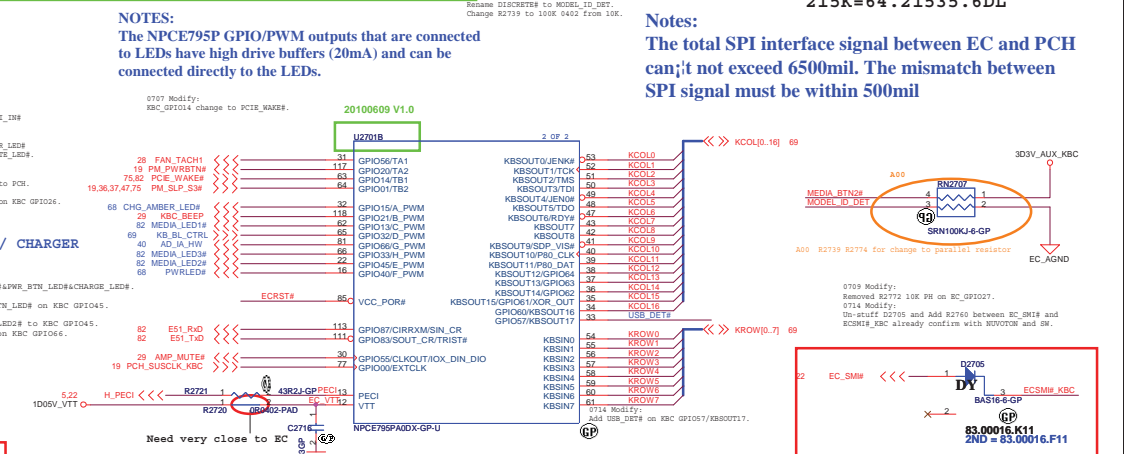
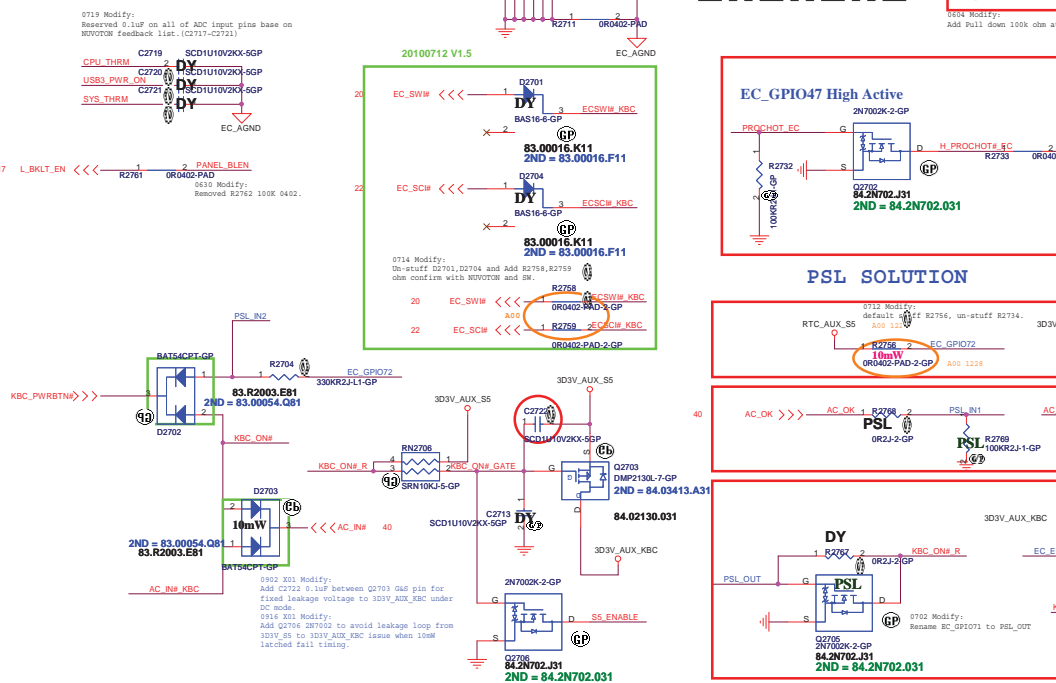

NOTES:
Please make sure there's no pull-down resistor on USB_PWR_EN#,AC_PRESENT,ES1_TXD.

SSID = Thermal

Thermal sensor P2800

0705 Modify:
R2802 change to 0ohm 0402 from short pad and default un-stuff.

Fan controller P2793

1119 X02 Modify:
Change U2801,U2804,U2805 VCC power to 3D3V_DAC_S0 from 3D3V_S0.

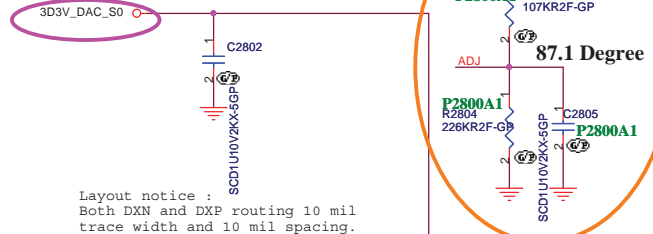

A00 1227

1111 X02 Modify:
ADJ&ADJ_VGA power source change to 3D3V_DAC_S0 from 3D3V_S0 to solve T8 shut down issue.

1227 A00 Modify:
If stuff P2800E1 then must stuff R2803,R2804,C2805 but if stuff P2800B0 should be unstuff.

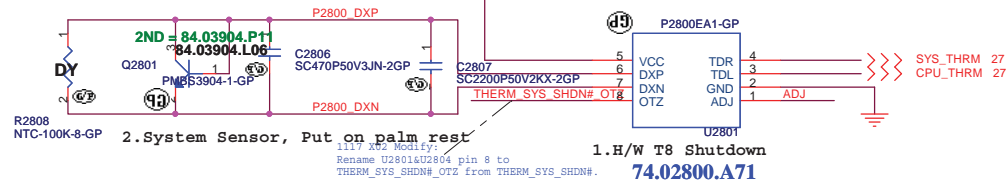

ADJ Table (Reference to SYNTON-TECH Metal Film Resistor E-96 ±1% Series)

RADJ1 (KΩ)	RADJ2 (KΩ)	VADJ (V)	OTZ Threshold Temperature (°C)
124	226	2.13	101
118	226	2.17	96.3
113	226	2.20	92.1
110	226	2.22	89.6
107	226	2.24	87
105	226	2.25	85.3
100	226	2.29	80.9

A00 1228 Cancel VGA Thermal sensor P2800 circuit

	Pin-1	Definition
P2793A	/FON	Low(<0.4V): VOUT =Vin and the fan is fully-on High(>1.6V): VOUT=1.6*VSET This pin is internal Pull-High with ~500K ohm
P2793B	EN	Low (<0.4): IC is shutdown. High(>1.6V): VOUT=1.6*VSET This pin is internal Pull-High with ~500K ohm

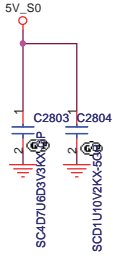
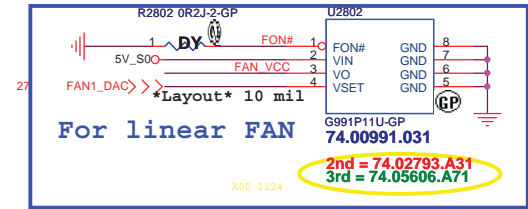

0614 Modify:
Change FAN1 connector part number to 20.D0210.103 base on ME EMN and DXF.
0712 Modify:
Change FAN1 part number to 20.F1639.004 from 20.D0210.103 base on latest EMN and DXF.

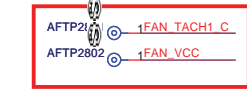
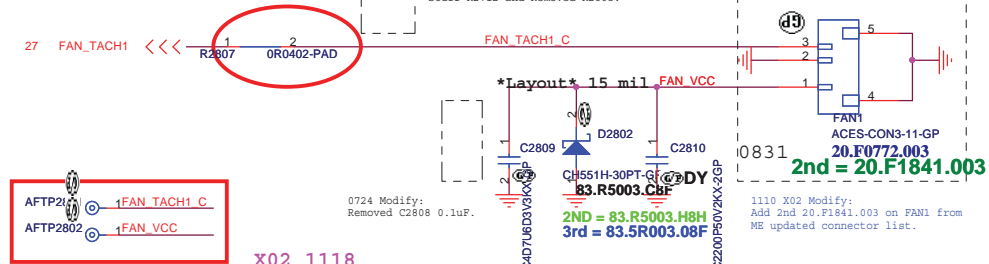

0724 Modify:
Removed C2808 0.1uF.

1110 X02 Modify:
Add 2nd 20.F1841.003 on FAN1 from ME updated connector list.

EMI/ESD

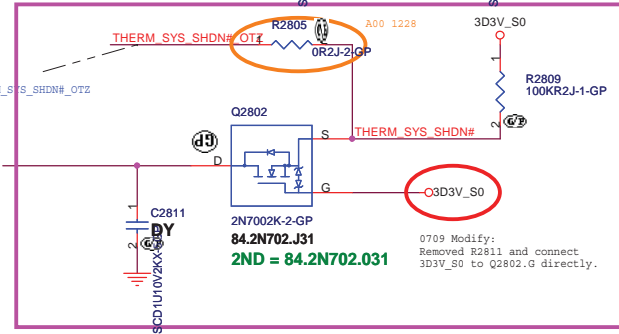
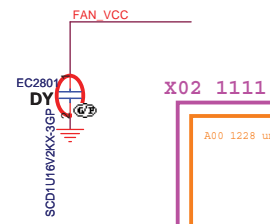

1117 X02 Modify:
Add R2805 Ohm between THERM_S SYS_SHDN# OTZ and THERM_SYS_SHDN#.

27.36.86 PURE_HW_SHUTDOWN# <<<

0709 Modify:
Removed R2811 and connect 3D3V_S0 to Q2802.G directly.

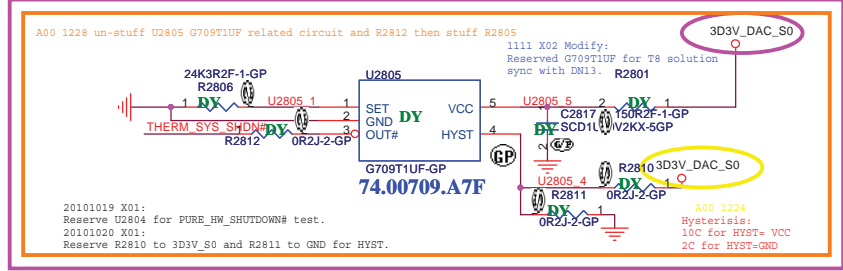

20101019 X01:
Reserve U2804 for PURE_HW_SHUTDOWN# test.
20101020 X01:
Reserve R2810 to 3D3V_S0 and R2811 to GND for HYST.

1111 X02 Modify:
ADJ&ADJ_VGA power source change to 3D3V_DAC_S0 from 3D3V_S0 to solve T8 shut down issue.

<Core Design>

Wistron Corporation
21F, 88, Sec.1, Hsin Tai Wu Rd., Hsichih, Taipei Hsien 221, Taiwan, R.O.C.

Title: **Thermal P2800/Fan Controller P2793**

Size A3 Document Number: **QUEEN 15** Rev: **A00**

Date: Tuesday, January 04, 2011 Sheet 28 of 108

SSID = AUDIO

For EMI

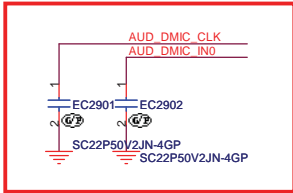

1122 X02 Modify:
change R2920, R2921 to 22ohm from 0ohm and
stuff SC2901, EC2902 22p from BMC Neo updated.

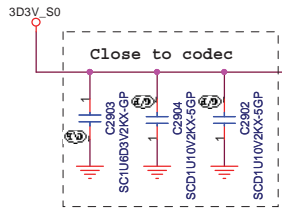

21 HDA_CODEC_SDOOUT
21 HDA_CODEC_BITCLK
21 HDA_SDIN0

21 HDA_CODEC_SYNC
21 HDA_CODEC_RST#

27 AMP_MUTE# >>> AMP_MUTE#

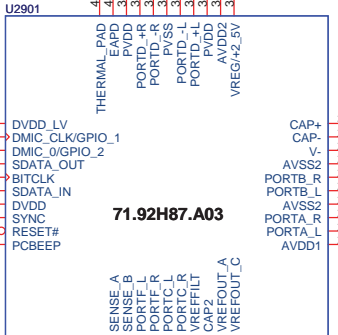
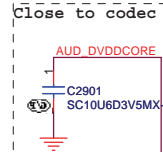

AUD_SPK_R+ 58
AUD_SPK_R- 58
AUD_SPK_L- 58
AUD_SPK_L+ 58

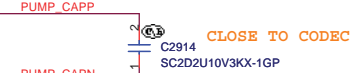
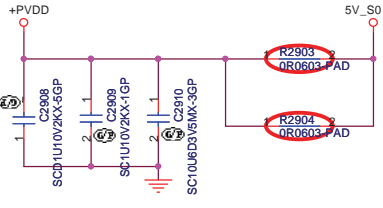
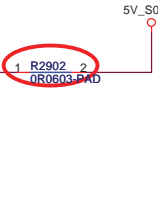
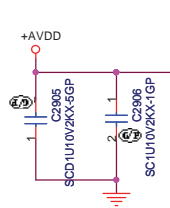

CLOSE TO CODEC

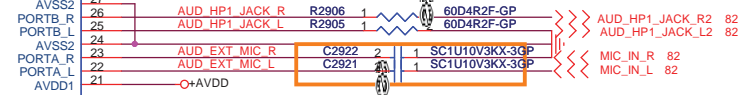

Put C2921 and C2922 close to codec

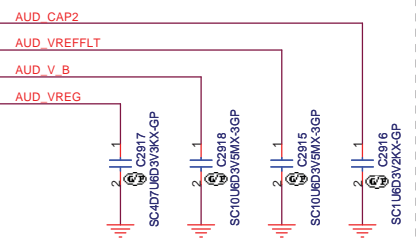

Close to codec

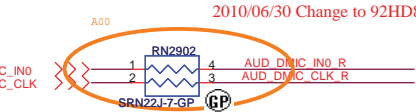

2010/06/30 Change to 92HD87 (71.92H87.A03)

49 AUD_DMIC_IN0
49 AUD_DMIC_CLK

0707 Modify:
Change R2911, R2914, R2917 change
to 0ohm 0603 from short pad.
0726 Modify:
Removed all of AUD_AGND and R2911, R2914, R2917.

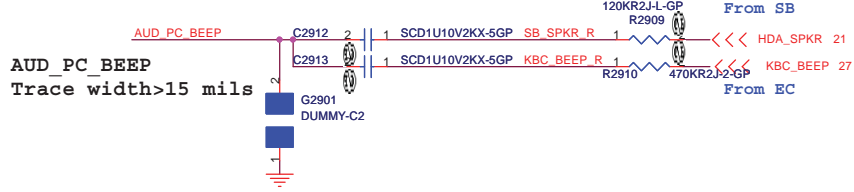
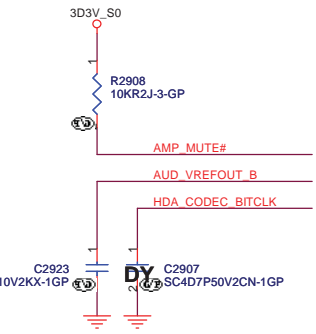

AUD_PC_BEEP
Trace width > 15 mils

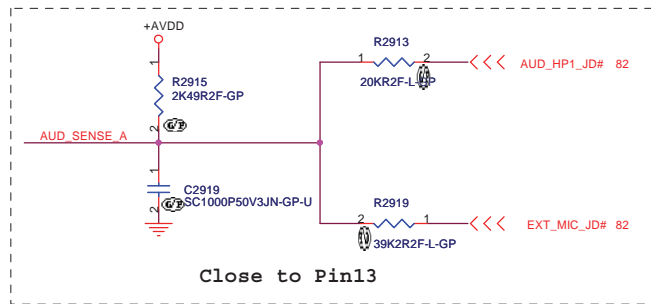
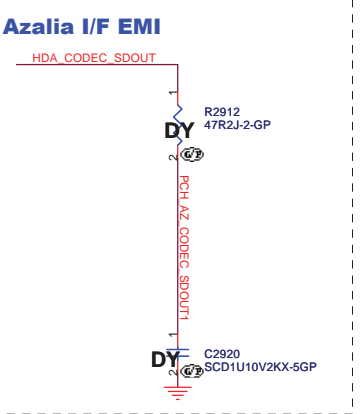

Close to Pin13

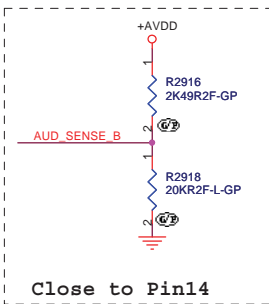

Close to Pin14

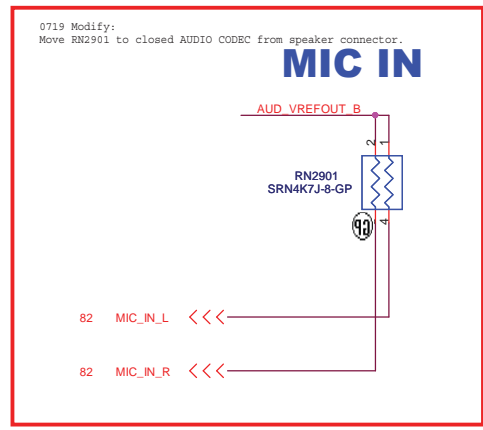

0719 Modify:
Move RN2901 to closed AUDIO CODEC from speaker connector.

MIC IN

<Core Design>



Title			Audio Codec 92HD87B1		
Size	Document Number		Rev		A00
A3	QUEEN 15				
Date:	Tuesday, January 04, 2011	Sheet	29	of	108

(Blanking)

<Core Design>

		Wistron Corporation 21F, 88, Sec. 1, Hsin Tai Wu Rd., Hsichih, Taipei Hsien 221, Taiwan, R.O.C.
Title		
Reserved		
Size A3	Document Number QUEEN 15	Rev A00
Date: Tuesday, January 04, 2011	Sheet 30	of 108

(Blanking)

<Core Design>



Title **Reserved**

Size A3	Document Number QUEEN 15	Rev A00
------------	------------------------------------	-------------------

Date: Tuesday, January 04, 2011 Sheet 31 of 108

SSID = SDIO

48MHz clock input trace of characteristic impedance (Z_0) must be 50 Ω \pm 15%.

20 CLK_PCH_48M >>>

PCH GPIO67(48M) confirm with SW

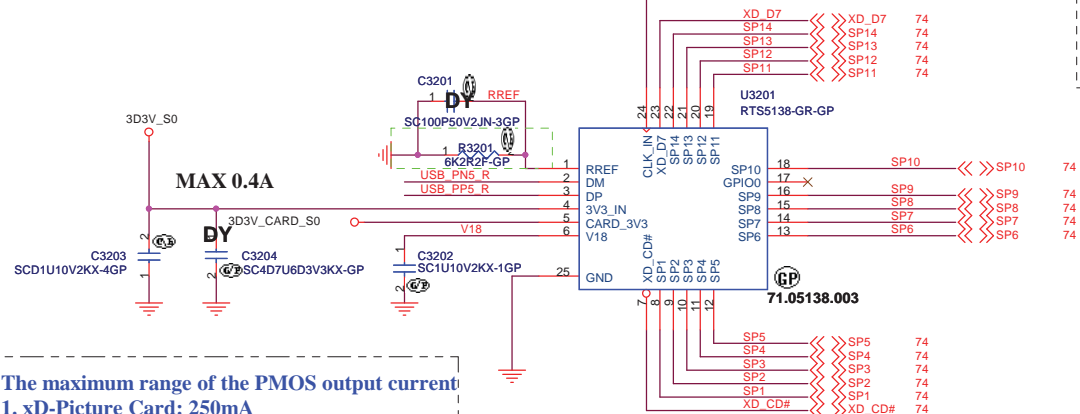

The maximum range of the PMOS output current
 1. xD-Picture Card: 250mA
 2. SD/MMC Card: 250mA
 3. MS/MSPRO/Duo-HG: 250mA

- POWER TRACE**
1. RTS5138: pin 4 (3V3_IN) trace fixed width is 30 mils (minimum).
 2. RTS5138: pin 5 (CARD_3V3) trace fixed width is 30 mils (minimum).
 3. RTS5138: pin 6 (V18) trace fixed width is 12 mils (minimum). Keep the trace routing lengths as short as possible.
 4. RTS5138: pin 1 (RREF) trace fixed width is 12 mils (minimum).
 5. RTS5138: pin 1 (RREF) trace must far away 48MHz clock trace.
 6. De-coupling and Bulk capacitor should place near to RTS5138 chip and Combo Socket.
 7. It is recommended that use of ferrites bead on power trace.
 8. Via size: Pad >= 32 mils, Finished hole >= 16 mils.

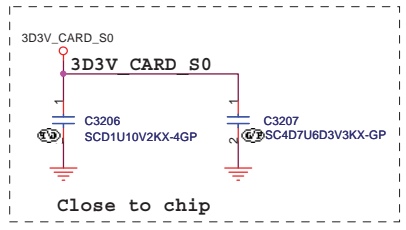

The pin2 / pin3 (DM/DP) of RTS5138 chip trace layout with differential characteristic impedance (Z_{diff}) is 90 Ω \pm 10%

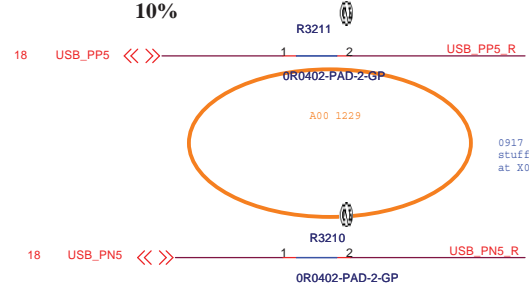

0917 X01 Modify:
 stuff TR3201 and un-stuff R3211, R3210
 at X01 stage from EMC Neo suggestion.

<Core Design>

Wistron Corporation
 21F, 88, Sec.1, Hsin Tai Wu Rd., Hsichih,
 Taipei Hsien 221, Taiwan, R.O.C.

Title: **Card Reader-RTS5138**

Size: A3	Document Number: QUEEN 15	Rev: A00
Date: Tuesday, January 04, 2011	Sheet: 32 of 108	

(Blanking)

<Core Design>

		Wistron Corporation 21F, 88, Sec. 1, Hsin Tai Wu Rd., Hsichih, Taipei Hsien 221, Taiwan, R.O.C.
Title		
Reserved		
Size A3	Document Number QUEEN 15	Rev A00
Date: Tuesday, January 04, 2011		Sheet 33 of 108

(Blanking)

<Core Design>



Title **Reserved**

Size A3	Document Number QUEEN 15	Rev A00
------------	------------------------------------	-------------------

Date: Tuesday, January 04, 2011 Sheet 34 of 108

(Blanking)

<Core Design>

		Wistron Corporation 21F, 88, Sec. 1, Hsin Tai Wu Rd., Hsichih, Taipei Hsien 221, Taiwan, R.O.C.
Title		
Reserved		
Size A3	Document Number QUEEN 15	Rev A00
Date: Tuesday, January 04, 2011		Sheet 35 of 108

SSID = Reset.Suspend

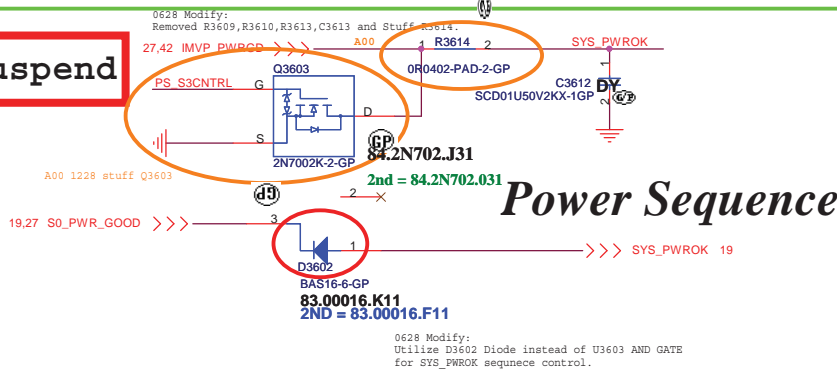

Power Sequence

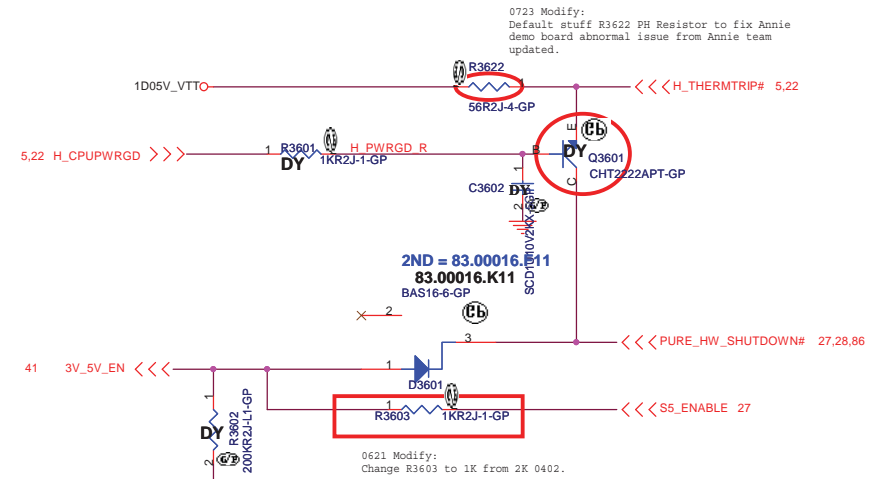

ROSA Run Power

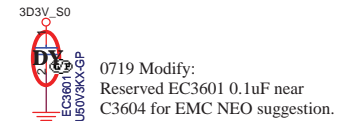
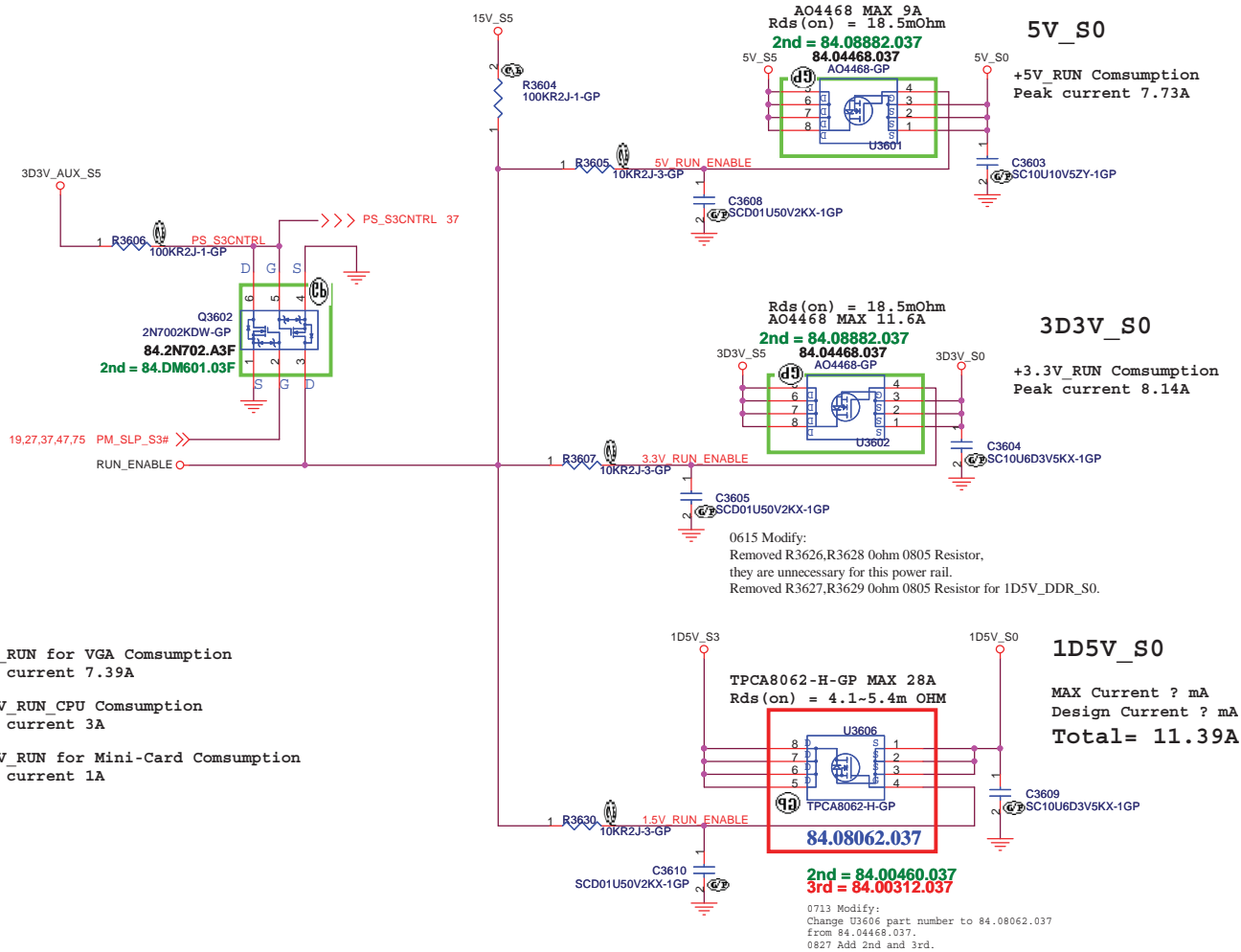

<Core Design>

DELL Wistron Corporation
21F, 88, Sec.1, Hsin Tai Wu Rd., Hsichih, Taipei Hsien 221, Taiwan, R.O.C.

Title: **Power Plane Enable**

Size A3	Document Number	Rev
	QUEEN 15	A00
Date: Tuesday, January 04, 2011	Sheet 36 of 108	

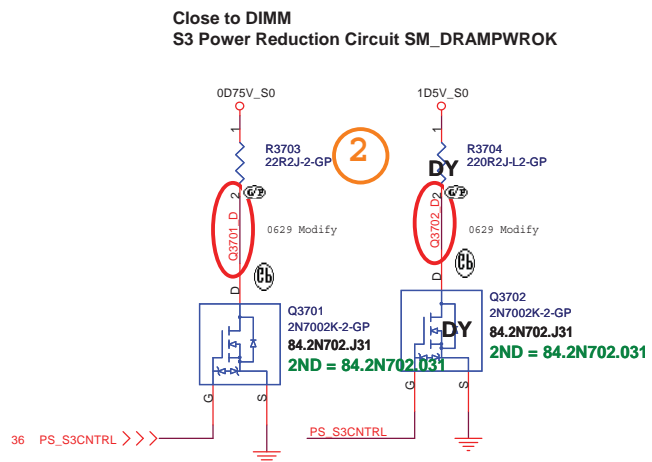
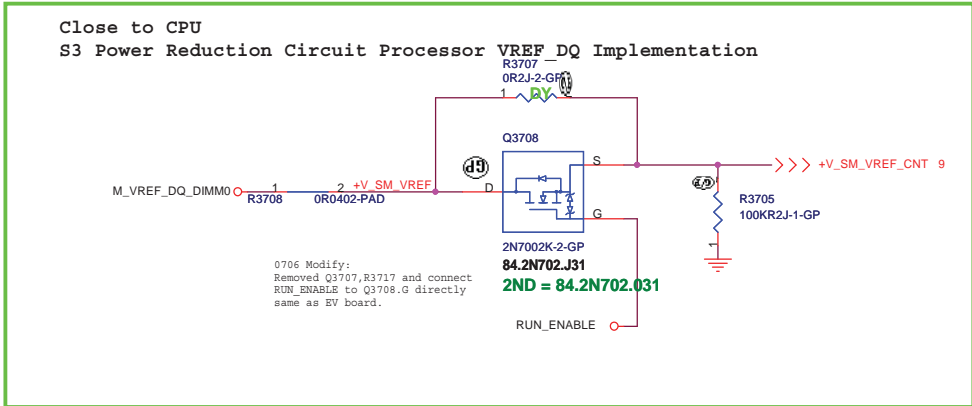

5 S3 Power Reduction X01 20091111

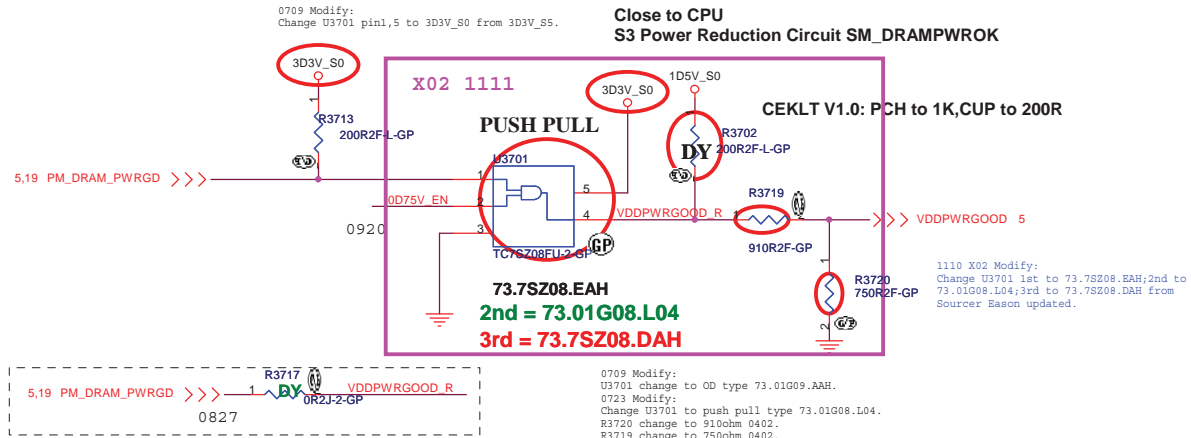
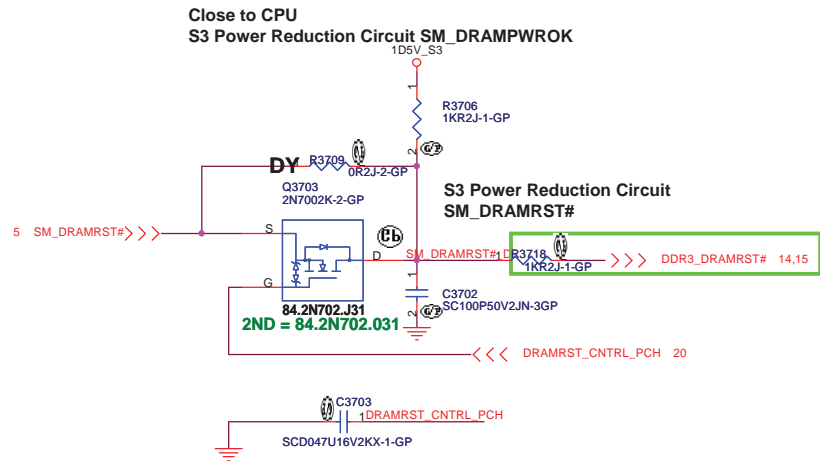
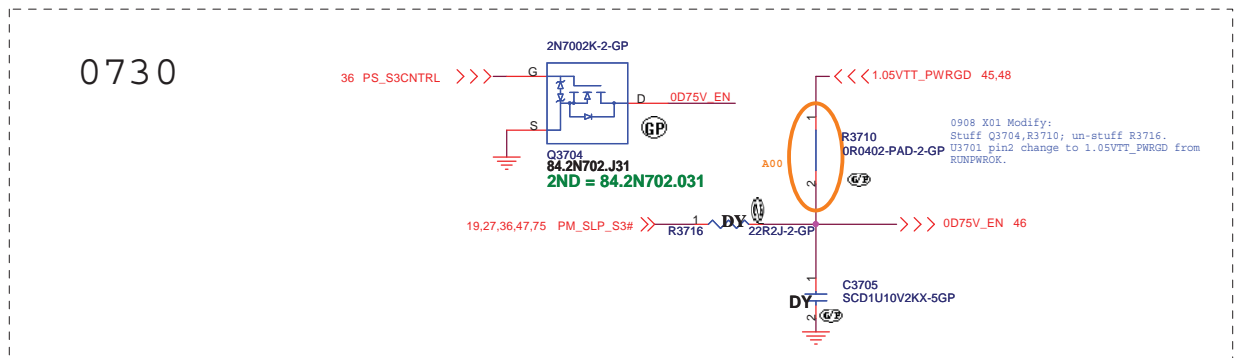

SM DRAMPWROK must have a maximum of 15ns rise or fall time over VDDQ * 0.55; 200mV and the edge must be monotonic

DN15ATI

DELL Wistron Corporation
 21F, 88, Sec. 1, Hsin Tai Wu Rd., Hsichih, Taipei Hsien 221, Taiwan, R.O.C.

Title
ADAPTER

Size A3 Document Number
QUEEN 15

Date: Tuesday, January 04, 2011 Sheet 37 of 108

Rev A00

SSID = PWR.Support

(Blanking)

<Core Design>



Title		DCIN	
Size	Document Number	Rev	
A3	QUEEN 15	A00	
Date: Tuesday, January 04, 2011		Sheet	38 of 108

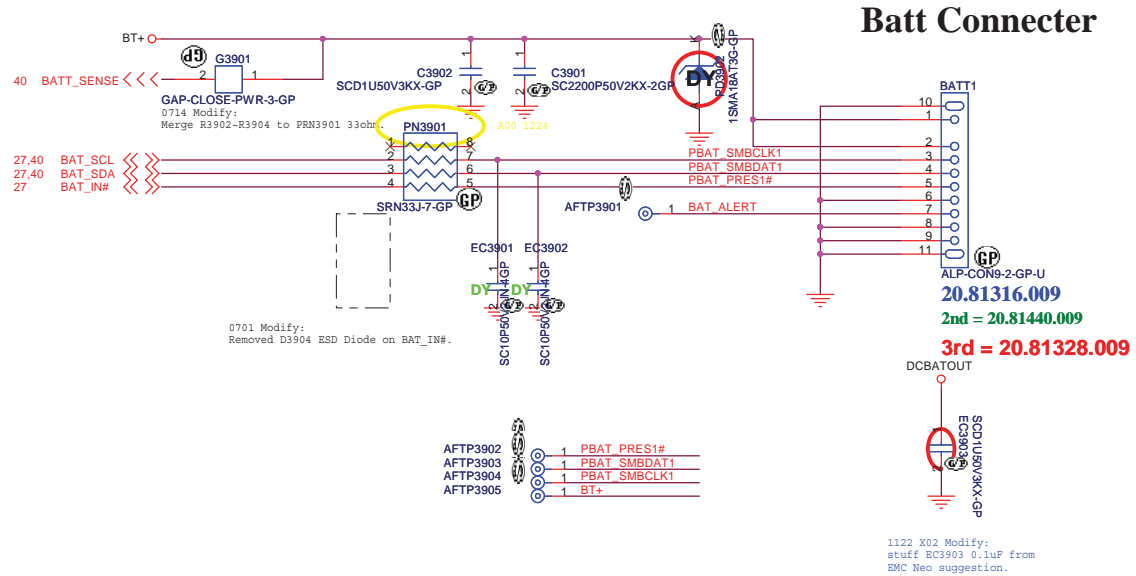

For actual location, need to be swap all pin

Close to Batt Connector

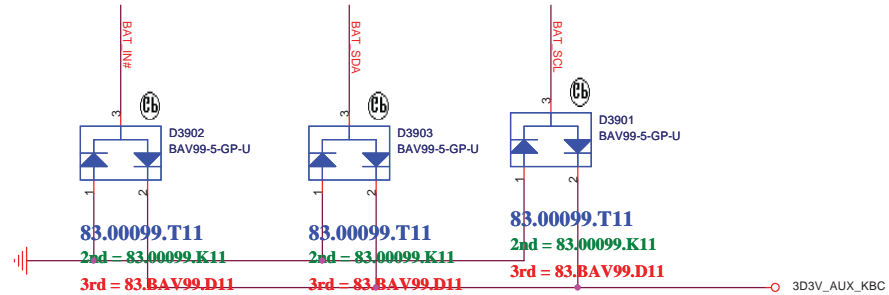

0930 X01 Modify:
Change D3901-D3903 main source to 83.00099.T11
for 83.BAV99.D11 shortage issue.

<Core Design>

Wistron Corporation
 21F, 88, Sec.1, Hsin Tai Wu Rd., Hsichih,
 Taipei Hsien 221, Taiwan, R.O.C.

BATT CONN		
Title		
Size	Document Number	Rev
A3	QUEEN 15	A00
Date: Tuesday, January 04, 2011	Sheet 39 of 108	

SSID = Charger

Id=-12A
Qg=-25nC
Rdson=10~38mohm

0719 Modify:
Reserved EC4006 0.1uF near PR4002
for EMC NEO suggestion.

0719 Modify:
Reserved EC4007 0.1uF near PG4006
for EMC NEO suggestion.

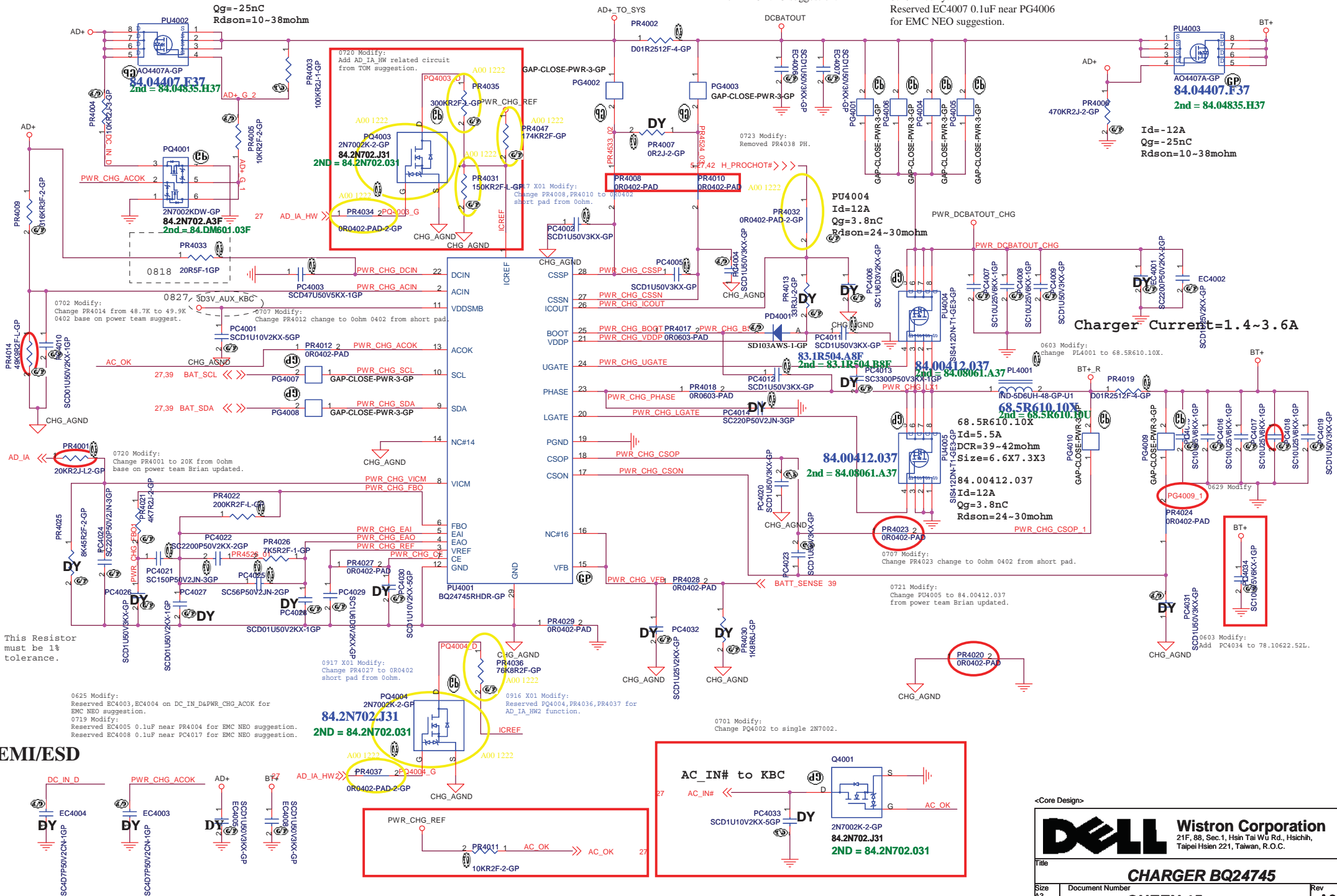

This Resistor must be 1% tolerance.

Charger Current=1.4~3.6A

EMI/ESD

<Core Design>

Wistron Corporation
21F, 88, Sec. 1, Hsin Tai Wu Rd., Hsichih, Taipei Hsien 221, Taiwan, R.O.C.

Title	CHARGER BQ24745		Rev
Size	Document Number	QUEEN 15	A00
A3	Date: Tuesday, January 04, 2011		Sheet 40 of 108

SSID = PWR.Plane.Regulator_5v3p3v

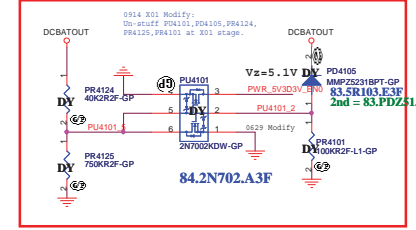
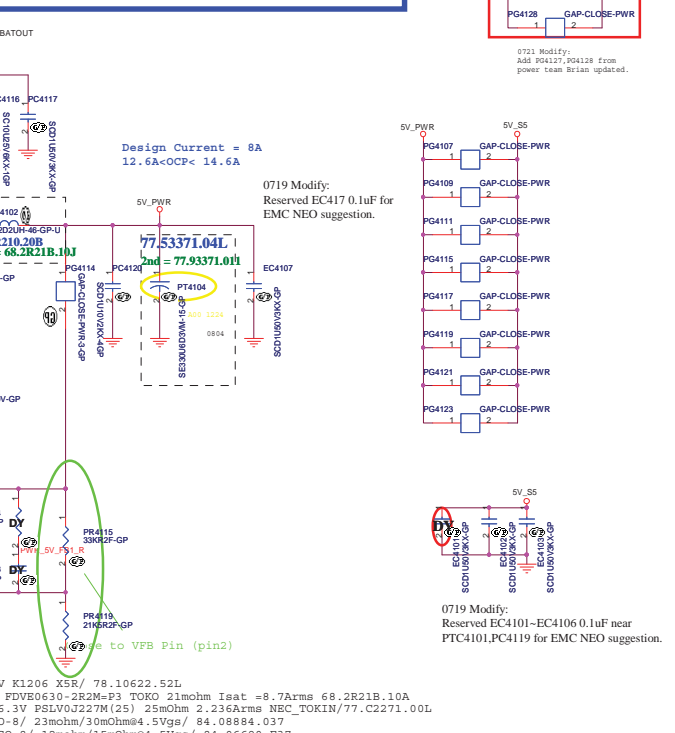
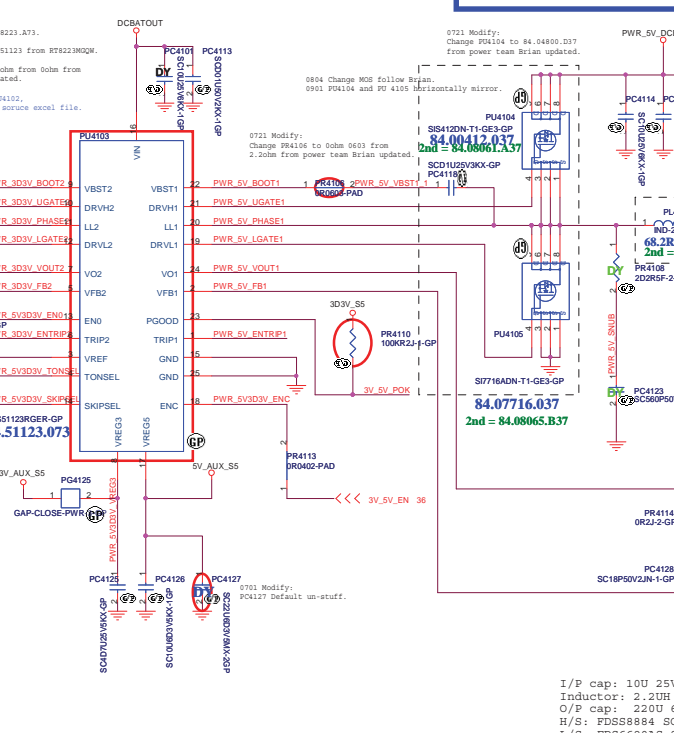
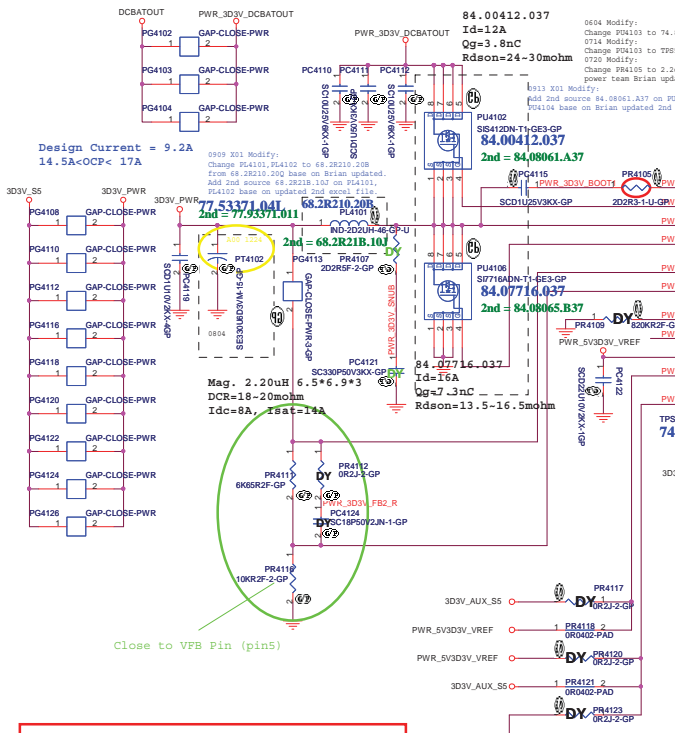
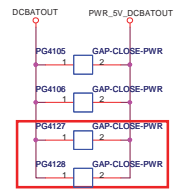
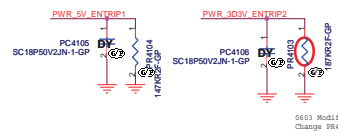
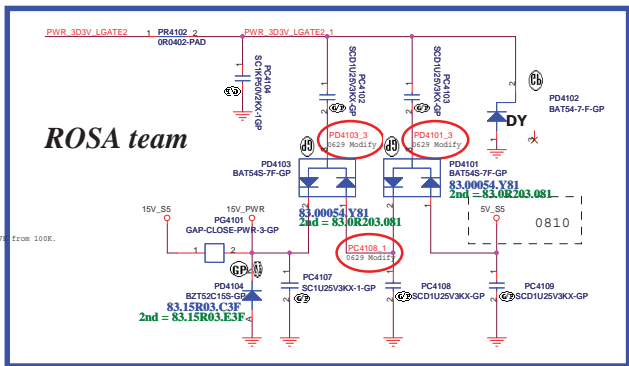

TONSEL	CH1	CH2
GND	200kHz	250kHz
VREF	300kHz	375kHz
VREG3 or VREG5	400kHz	500kHz

SKIPSEL	VREG3 or VREG5	VREF (2V)	GND
Operating Mode	OOA Auto Skip	Auto Skip	PWM only

I/P cap: 10U 25V K1206 X5R/ 79.10622.52L
 Inductor: 2.2uH FDVE0630-2R2M=P3 TOKO 21mohm Isat = 8.7Arms 68.2R21B.10A
 O/P cap: 220U 6.3V PSLV0J227M(25) 25mOhm 2.236Arms NEC_TOKIN/77.C2271.00L
 H/S: FDS8884 SO-8/ 23mohm/30mOhm@4.5Vgs/ 84.08884.037
 L/S: FDS6690AS SO-8/ 12mohm/15mOhm@4.5Vgs/ 84.06690.E37

SSSID = CPU.Regulator

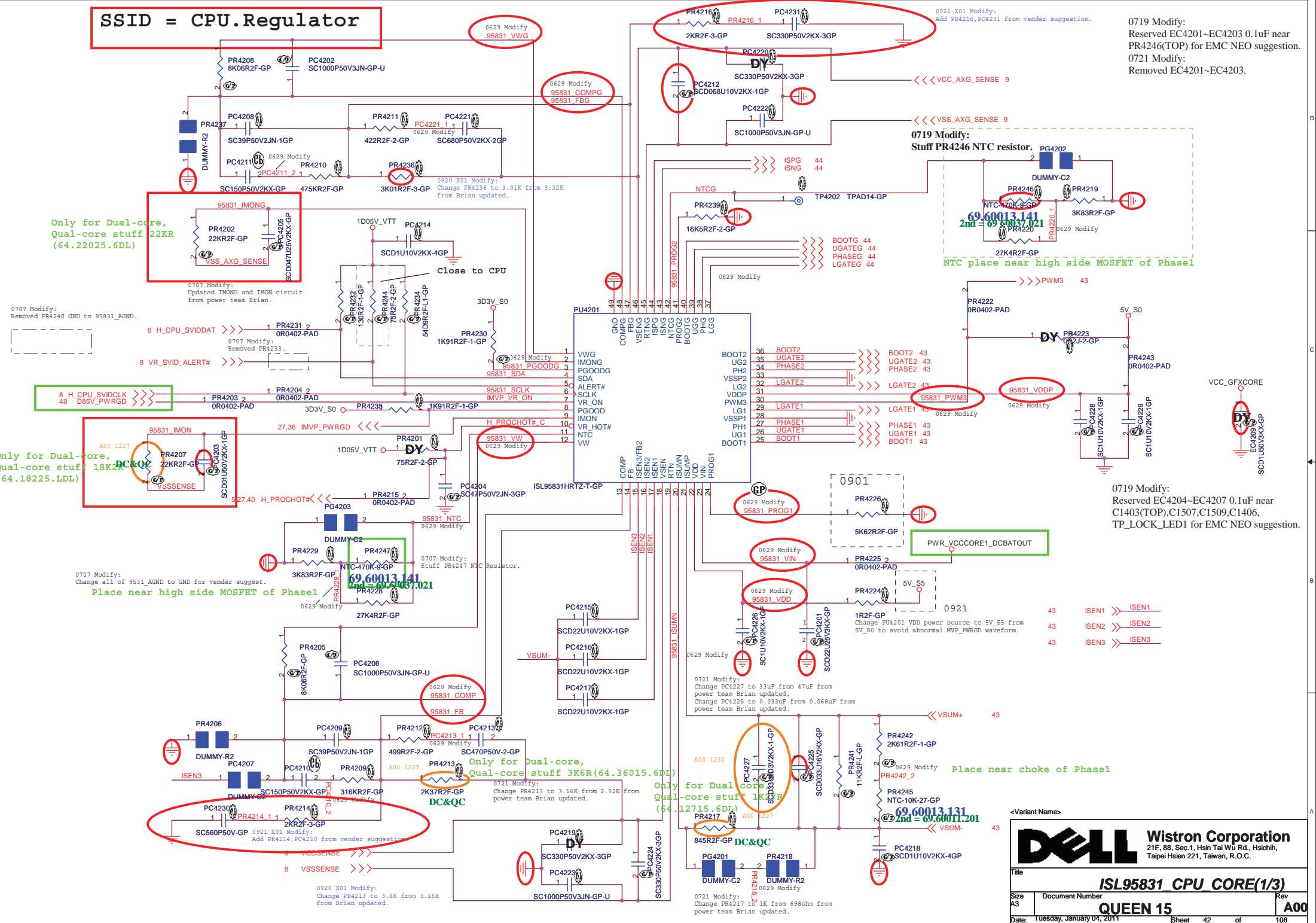

Only for Dual-core,
Qual-core stuff 22K (64.22025.6DL)

0707 Modify:
Updated IMONG and IMON circuit
from power team Brian.

0707 Modify:
Removed PR4240 GND to 95831_AGND.

8 H_CPU_SVIDDAT >>>
0707 Modify:
Removed PR4233.

8 H_CPU_SVIDCLK
48 D85V_PWRGD >>>

0707 Modify:
Change all of 9511_AGND to GND for vander suggest.
Place near high side MOSFET of Phase1

Only for Dual-core,
Qual-core stuff 3K6R (64.36015.6DL)

Only for Dual-core
Qual-core stuff 1K07R
(54.12715.6DL)

0920 X01 Modify:
Change PR4213 to 3.6K from 3.16K
from Brian updated.

0721 Modify:
Change PR4217 to 1K from 690ohm from
power team Brian updated.

0629 Modify
95831_VWG

0629 Modify
95831_COMPG
95831_FBG

0921 X01 Modify:
Add PR4216, PC4231 from vander suggestion

0719 Modify:
Stuff PR4246 NTC resistor.

NTC place near high side MOSFET of Phase1

0719 Modify:
Reserved EC4201-EC4203 0.1uF near
PR4246(TOP) for EMC NEO suggestion.
0721 Modify:
Removed EC4201-EC4203.

0629 Modify
95831_VVW

0629 Modify
95831_PROG1

0629 Modify
95831_VDD

0629 Modify
95831_COMP
95831_FB

0629 Modify
95831_ISUMN

0721 Modify:
Change PR4217 to 1K from 690ohm from
power team Brian updated.

0629 Modify
95831_PG00DG

0629 Modify
95831_VDDP

0629 Modify
95831_VDD

0719 Modify:
Reserved EC4204-EC4207 0.1uF near
C1403(TOP), C1507, C1509, C1406,
TP_LOCK_LED1 for EMC NEO suggestion.

0629 Modify
95831_ISUMN

0629 Modify
95831_VDD

0629 Modify
95831_VDD

0721 Modify:
Change PR4217 to 1K from 690ohm from
power team Brian updated.

0629 Modify
95831_VDD

0629 Modify
95831_VDD

0629 Modify
95831_VDD

0629 Modify
95831_VDD

0629 Modify
95831_VDD

0629 Modify
95831_VDD

0629 Modify
95831_VDD

0629 Modify
95831_VDD

0629 Modify
95831_VDD

0629 Modify
95831_VDD

0629 Modify
95831_VDD

0629 Modify
95831_VDD

0629 Modify
95831_VDD

0629 Modify
95831_VDD

0629 Modify
95831_VDD

0629 Modify
95831_VDD

0629 Modify
95831_VDD

0629 Modify
95831_VDD

0629 Modify
95831_VDD

0629 Modify
95831_VDD

0629 Modify
95831_VDD

0629 Modify
95831_VDD

0629 Modify
95831_VDD

0629 Modify
95831_VDD

0629 Modify
95831_VDD

0629 Modify
95831_VDD

0629 Modify
95831_VDD

0629 Modify
95831_VDD

0629 Modify
95831_VDD

0629 Modify
95831_VDD

0629 Modify
95831_VDD

0629 Modify
95831_VDD

0629 Modify
95831_VDD

0629 Modify
95831_VDD

0629 Modify
95831_VDD

0629 Modify
95831_VDD

0629 Modify
95831_VDD

0629 Modify
95831_VDD

0629 Modify
95831_VDD

0629 Modify
95831_VDD

0629 Modify
95831_VDD

0629 Modify
95831_VDD

0629 Modify
95831_VDD

0629 Modify
95831_VDD

0629 Modify
95831_VDD

0629 Modify
95831_VDD

0629 Modify
95831_VDD

0629 Modify
95831_VDD

0629 Modify
95831_VDD

0629 Modify
95831_VDD

0629 Modify
95831_VDD

0629 Modify
95831_VDD

0629 Modify
95831_VDD

0629 Modify
95831_VDD

0629 Modify
95831_VDD

0629 Modify
95831_VDD

0629 Modify
95831_VDD

0629 Modify
95831_VDD

0629 Modify
95831_VDD

0629 Modify
95831_VDD

0629 Modify
95831_VDD

0629 Modify
95831_VDD

0629 Modify
95831_VDD

0629 Modify
95831_VDD

0629 Modify
95831_VDD

0629 Modify
95831_VDD

0629 Modify
95831_VDD

0629 Modify
95831_VDD

0629 Modify
95831_VDD

0629 Modify
95831_VDD

0629 Modify
95831_VDD

0629 Modify
95831_VDD

0629 Modify
95831_VDD

0629 Modify
95831_VDD

0629 Modify
95831_VDD

0629 Modify
95831_VDD

0629 Modify
95831_VDD

0629 Modify
95831_VDD

0629 Modify
95831_VDD

0629 Modify
95831_VDD

0629 Modify
95831_VDD

0629 Modify
95831_VDD

0629 Modify
95831_VDD

0629 Modify
95831_VDD

0629 Modify
95831_VDD

0629 Modify
95831_VDD

0629 Modify
95831_VDD

0629 Modify
95831_VDD

0629 Modify
95831_VDD

0629 Modify
95831_VDD

0629 Modify
95831_VDD

0629 Modify
95831_VDD

0629 Modify
95831_VDD

0629 Modify
95831_VDD

0629 Modify
95831_VDD

0629 Modify
95831_VDD

0629 Modify
95831_VDD

0629 Modify
95831_VDD

0629 Modify
95831_VDD

0629 Modify
95831_VDD

0629 Modify
95831_VDD

0629 Modify
95831_VDD

0629 Modify
95831_VDD

0629 Modify
95831_VDD

0629 Modify
95831_VDD

0629 Modify
95831_VDD

0629 Modify
95831_VDD

0629 Modify
95831_VDD

0629 Modify
95831_VDD

0629 Modify
95831_VDD

0629 Modify
95831_VDD

0629 Modify
95831_VDD

0629 Modify
95831_VDD

0629 Modify
95831_VDD

0629 Modify
95831_VDD

0629 Modify
95831_VDD

0629 Modify
95831_VDD

0629 Modify
95831_VDD

0629 Modify
95831_VDD

0629 Modify
95831_VDD

0629 Modify
95831_VDD

0629 Modify
95831_VDD

0629 Modify
95831_VDD

0629 Modify
95831_VDD

0629 Modify
95831_VDD

0629 Modify
95831_VDD

0629 Modify
95831_VDD

0629 Modify
95831_VDD

0629 Modify
95831_VDD

0629 Modify
95831_VDD

0629 Modify
95831_VDD

0629 Modify
95831_VDD

0629 Modify
95831_VDD

0629 Modify
95831_VDD

0629 Modify
95831_VDD

0629 Modify
95831_VDD

0629 Modify
95831_VDD

0629 Modify
95831_VDD

0629 Modify
95831_VDD

0629 Modify
95831_VDD

0629 Modify
95831_VDD

0629 Modify
95831_VDD

0629 Modify
95831_VDD

0629 Modify
95831_VDD

0629 Modify
95831_VDD

0629 Modify
95831_VDD

0629 Modify
95831_VDD

0629 Modify
95831_VDD

0629 Modify
95831_VDD

0629 Modify
95831_VDD

0629 Modify
95831_VDD

0629 Modify
95831_VDD

0629 Modify
95831_VDD

0629 Modify
95831_VDD

0629 Modify
95831_VDD

0629 Modify
95831_VDD

0629 Modify
95831_VDD

0629 Modify
95831_VDD

0629 Modify
95831_VDD

0629 Modify
95831_VDD

0629 Modify
95831_VDD

0629 Modify
95831_VDD

0629 Modify
95831_VDD

0629 Modify
95831_VDD

0629 Modify
95831_VDD

0629 Modify
95831_VDD

0629 Modify
95831_VDD

0629 Modify
95831_VDD

0629 Modify
95831_VDD

0629 Modify
95831_VDD

0629 Modify
95831_VDD

0629 Modify
95831_VDD

0629 Modify
95831_VDD

0629 Modify
95831_VDD

0629 Modify
95831_VDD

0629 Modify
95831_VDD

0629 Modify
95831_VDD

0629 Modify
95831_VDD

0629 Modify
95831_VDD

0629 Modify
95831_VDD

0629 Modify
95831_VDD

0629 Modify
95831_VDD

0629 Modify
95831_VDD

0629 Modify
95831_VDD

0629 Modify
95831_VDD

0629 Modify
95831_VDD

0629 Modify
95831_VDD

0629 Modify
95831_VDD

0629 Modify
95831_VDD

0629 Modify
95831_VDD

0629 Modify
95831_VDD

0629 Modify
95831_VDD

0629 Modify
95831_VDD

0629 Modify
95831_VDD

0629

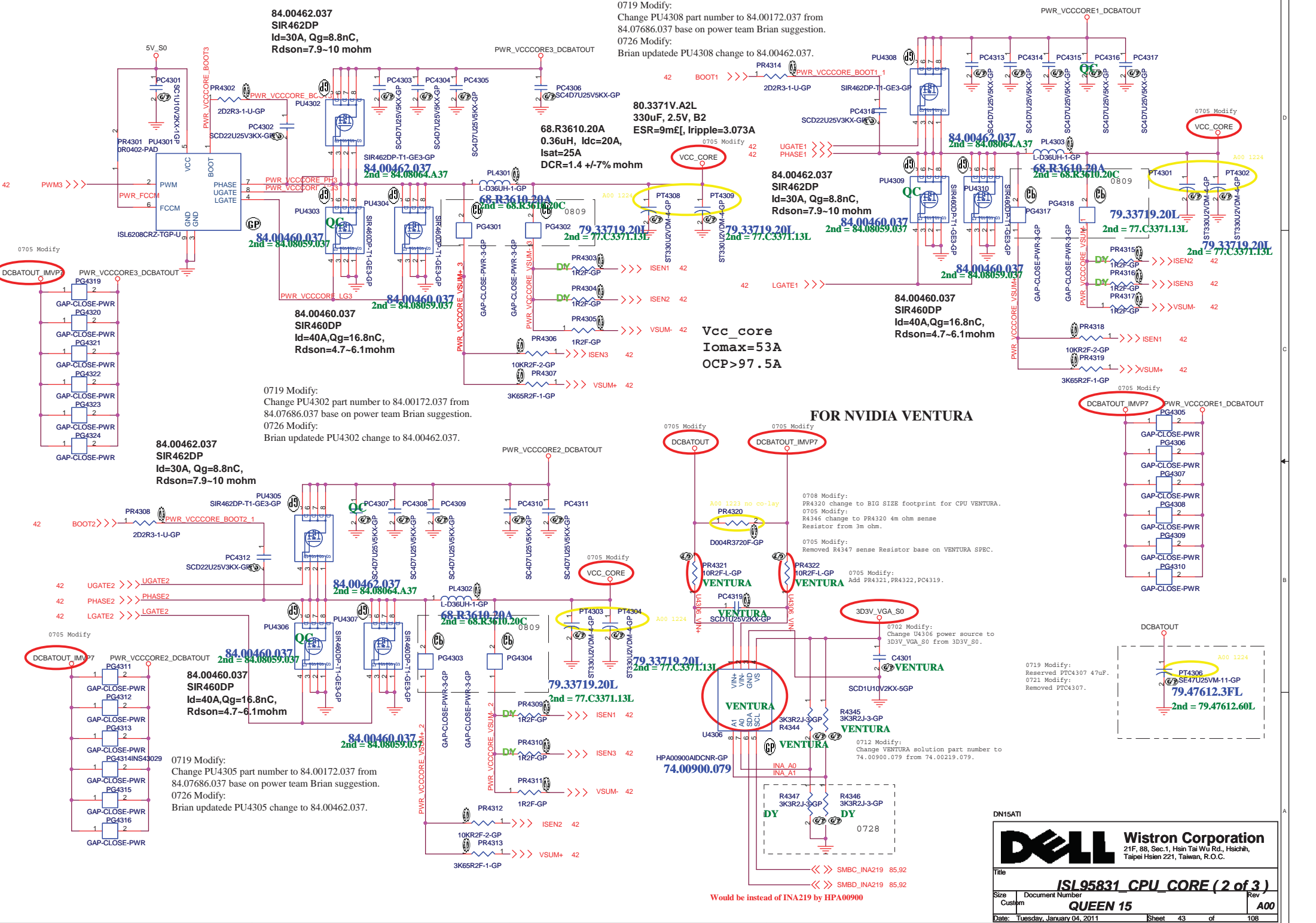

84.00462.037
SIR462DP
Id=30A, Qg=8.8nC,
Rdson=7.9-10 mohm

0719 Modify:
Change PU4308 part number to 84.00172.037 from
84.07686.037 base on power team Brian suggestion.
0726 Modify:
Brian updated PU4308 change to 84.00462.037.

80.3371V.A2L
330uF, 2.5V, B2
ESR=9mF, Irripple=3.073A

84.00462.037
SIR462DP
Id=30A, Qg=8.8nC,
Rdson=7.9-10 mohm

84.00460.037
SIR460DP
Id=40A, Qg=16.8nC,
Rdson=4.7-6.1mohm

84.00460.037
SIR460DP
Id=40A, Qg=16.8nC,
Rdson=4.7-6.1mohm

0719 Modify:
Change PU4302 part number to 84.00172.037 from
84.07686.037 base on power team Brian suggestion.
0726 Modify:
Brian updated PU4302 change to 84.00462.037.

84.00462.037
SIR462DP
Id=30A, Qg=8.8nC,
Rdson=7.9-10 mohm

84.00460.037
SIR460DP
Id=40A, Qg=16.8nC,
Rdson=4.7-6.1mohm

0719 Modify:
Change PU4305 part number to 84.00172.037 from
84.07686.037 base on power team Brian suggestion.
0726 Modify:
Brian updated PU4305 change to 84.00462.037.

Vcc_core
Iomax=53A
OCP>97.5A

FOR NVIDIA VENTURA

0708 Modify:
PR4320 change to BIG SIZE footprint for CPU VENTURA.
0705 Modify:
R4346 change to PR4321 4m ohm sense
Resistor from 3m ohm.
0705 Modify:
Removed R4347 sense Resistor base on VENTURA SPEC.

0705 Modify:
Add PR4321, PR4322, PC4319.

0702 Modify:
Change U4306 power source to
3D3V_VGA_S0 from 3D3V_S0.

0712 Modify:
Change VENTURA solution part number to
74.00900.079 from 74.00219.079.



Title		ISL95831 CPU CORE (2 of 3)	
Size	Document Number	Rev	
Custom	QUEEN 15	A00	
Date:	Tuesday, January 04, 2011	Sheet	43 of 108

Would be instead of INA219 by HPA00900

0705 Modify

DCBATOUT_IMVP7

PWR_GFXCORE_DCBATOUT

0719 Modify:
 Change PU4401 part number to 84.00172.037 from 84.07686.037 base on power team Brian suggestion.
 0720 Modify:
 Change PU4401 part number to 84.00462.037 from 84.00172.037 base on power team Brian suggestion.

84.00462.037
SIR462DP-T1-GE3-GP
 Id=30A, Qg=8.8nC,
 Rds(on)=7.9 mohm

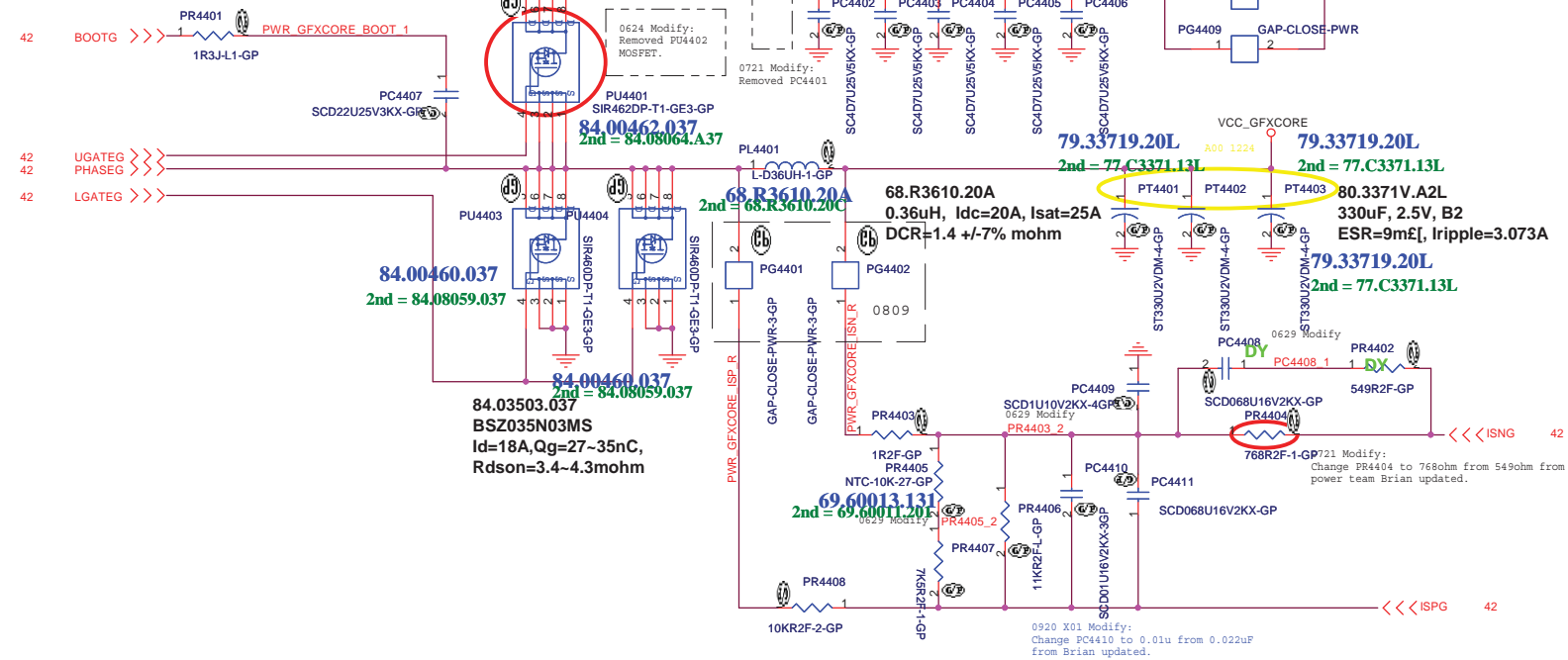

VCC_GFXCORE
 I_{omax}=33A
 OCP>50A

EMI/ESD

0715 Modify:
 Add EC4401-EC4410 for EMC NEO suggestion.

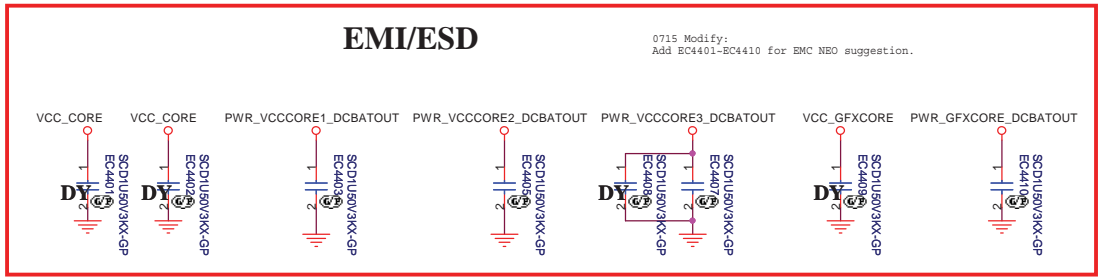

DN15ATI



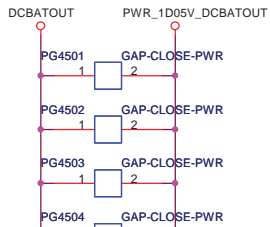

TPS51218 for 1D05V

1123 X02 Modify:
Change PR4501 to 75K from 45.3K
for 1.05V OCP set to 20A from Brian.

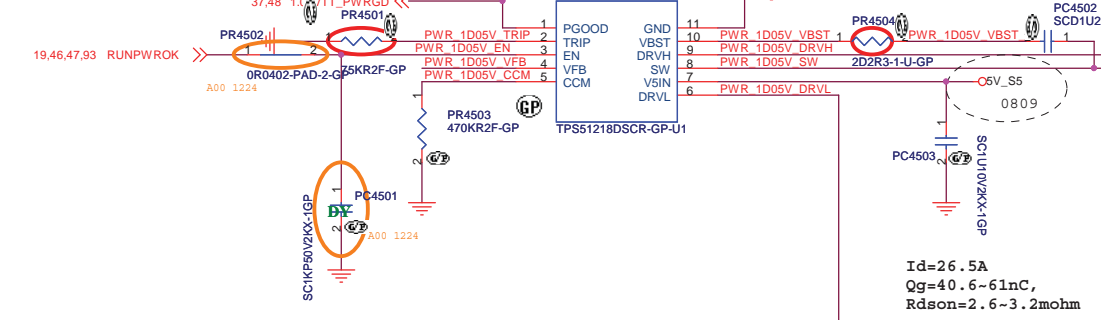

84.00172.037
BS2115N03MSC
Id=20A, Qg=9.8nC,
Rdson=8.9 mOhm

0721 Modify:
Change PR4504 to 2.2ohm from 0ohm from
power team Brian updated.

0719 Modify:
Change PU4502 part number to 84.00172.037 from
84.07686.037 base on power team Brian suggestion.

1122 X02 Modify:
stuff EC4501 0.1uF from
EMC Neo suggestion.

84.00172.037
2nd = 84.08065.037

0909 X01 Modify:
Change PL4501 to 68.2R210.20C
from IND-D56UH-27-GP base on
Brian updated.

84.00460.037
2nd = 84.08059.037

0721 Modify:
Brian suggest change PU4503 to 84.00460.037.
Change PR4506 to 9.76K from 10K from
power team Brian updated.

0727 Modify:
PR4505, PR4508 change to 100ohm from 10ohm.
stuff PR4509, PR4510 0ohm from Brian updated.

Design Current = 9.9A
15.6A < OCP < 18.3A

Mag. 2.20uH 10*11.5*4
DCR=6.7~7mohm
Idc=12A, Isat=27A

COIL-2D2UH-11-GP
68.2R210.20C
2nd = 68.2R21B.10I

79.3971V.30L
2nd = 77.93971.02L

0920 X01 Modify:
Change PR4507 to 20K from 20.5K
from Brian updated.

$$V_{out} = 0.704V * (R1 + R2) / R2$$

0617 Modify:
Joseph Change PTC4502 to 330uF from 390uF
base on layout placement status.

0721 Modify:
Brian Add PC4511 1uF. Change PTC4502 to 330uF 79.33719.L01.
0719 Modify:
Reserved EC4502, EC4503 0.1uF near
PG4516(TOP) for EMC NEO suggestion.

0901 X01 Modify:
Change PTC4502 to 79.3971V.30L from
79.33719.L01 from power team Brian updated.
0913 X01 Modify:
Add 2nd source 77.93971.02L on PTC4502
base on Brian updated 2nd source excel file.

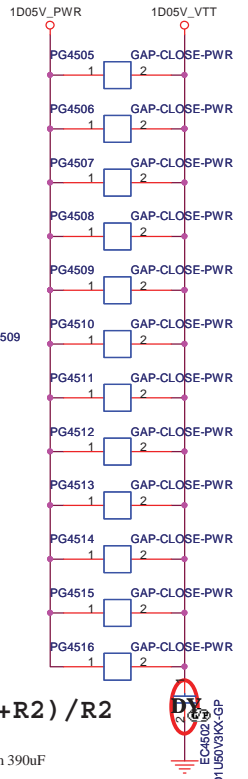

DN15ATI



Title			TPS51218 +1.05V VTT		
Size	Document Number		Rev		A00
A3	QUEEN 15				
Date:	Tuesday, January 04, 2011		Sheet	45	of 108

0719 Modify:
Change PU4602 part number to 84.00172.037 from 84.07686.037 base on power team Brian suggestion.

84.00172.037
BSZ115N03MSC
Id=20A, Qg=9.8nC,
Rdson=8.9 mohm

84.00460.037
SIR460DP-T1-GE3
Id=40A, QG=16.8nC,
Rdson=4.7~6.1 mohm

Design Current = 14.45A
22.71A < OCP < 26.84A

79.3971V.30L
2nd = 77.93971.02L

79.3971V.30L
390uF, 2.5V, 6.3X5.7
ESR=10mE[, Iripple=3.87A

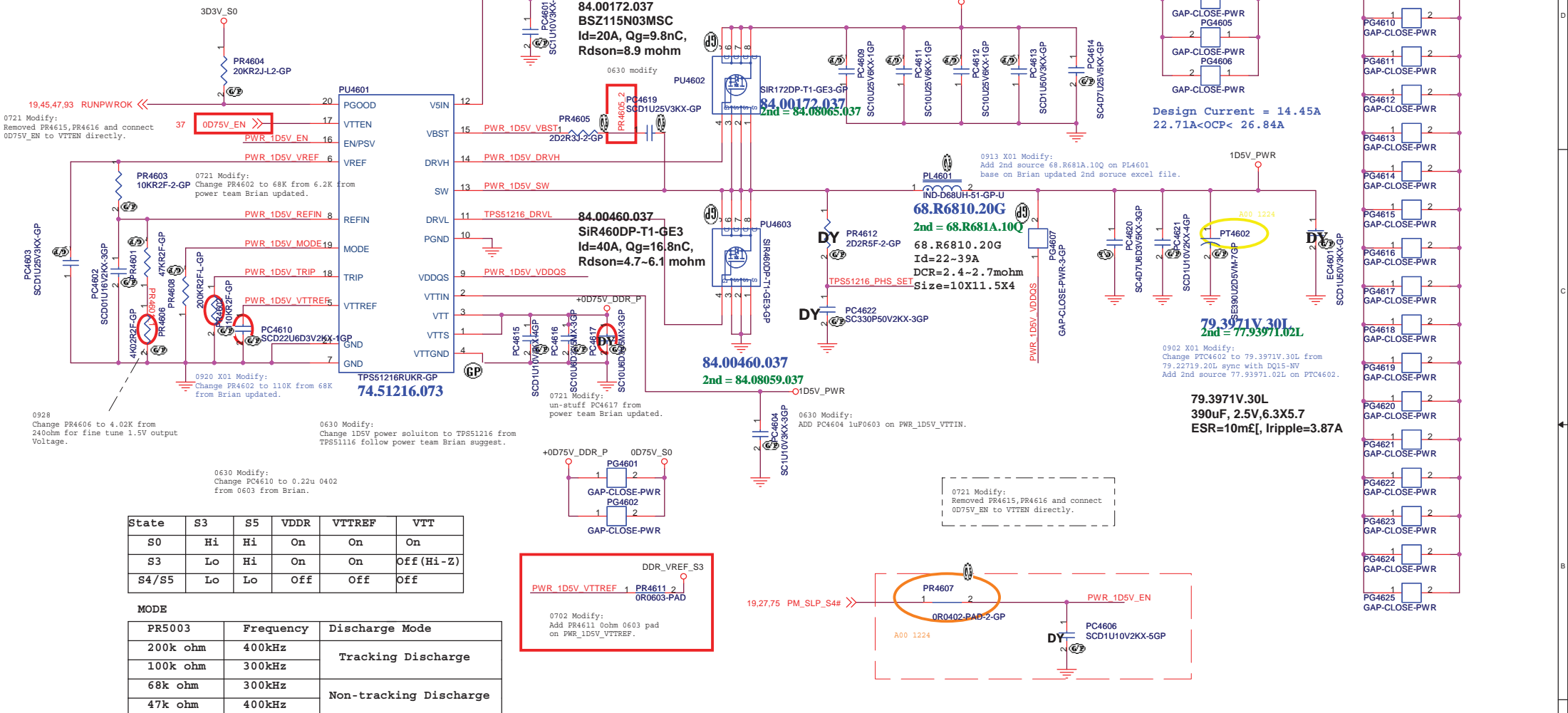

0721 Modify:
Removed PR4615, PR4616 and connect 0D75V_EN to VTTEN directly.

0721 Modify:
Change PR4602 to 68K from 6.2K power team Brian updated.

0920 X01 Modify:
Change PR4602 to 110K from 68K from Brian updated.

0928
Change PR4606 to 4.02K from 240ohm for fine tune 1.5V output Voltage.

0630 Modify:
Change 1D5V power solution to TPS51216 from TPS51116 follow power team Brian suggest.

0630 Modify:
Change PC4610 to 0.22u 0402 from 0603 from Brian.

0721 Modify:
un-stuff PC4617 from power team Brian updated.

0630 Modify:
ADD PC4604 1uF0603 on PWR_1D5V_VTTIN.

0721 Modify:
Removed PR4615, PR4616 and connect 0D75V_EN to VTTEN directly.

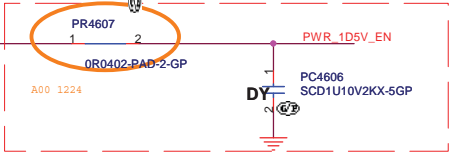

State	S3	S5	VDDR	VTTREF	VTT
S0	Hi	Hi	On	On	On
S3	Lo	Hi	On	On	Off (Hi-Z)
S4/S5	Lo	Lo	Off	Off	Off

MODE	Frequency	Discharge Mode
PR5003	400kHz	Tracking Discharge
200k ohm	300kHz	
100k ohm	300kHz	Non-tracking Discharge
68k ohm	400kHz	
47k ohm		

<Variant Name>

Wistron Corporation
21F, 88, Sec.1, Hsin Tai Wu Rd., Hsichih, Taipei Hsien 221, Taiwan, R.O.C.

Title: **TPS51116 +1.5V SUS**

Size A3	Document Number	Rev
	QUEEN 15	A00
Date: Tuesday, January 04, 2011	Sheet 46	of 108

SSID = PWR.Plane.Regulator_1D8V_S0

TPS51311 PWM for 1D8V_S0

+1.8V_RUN
Design current = 2.7985A

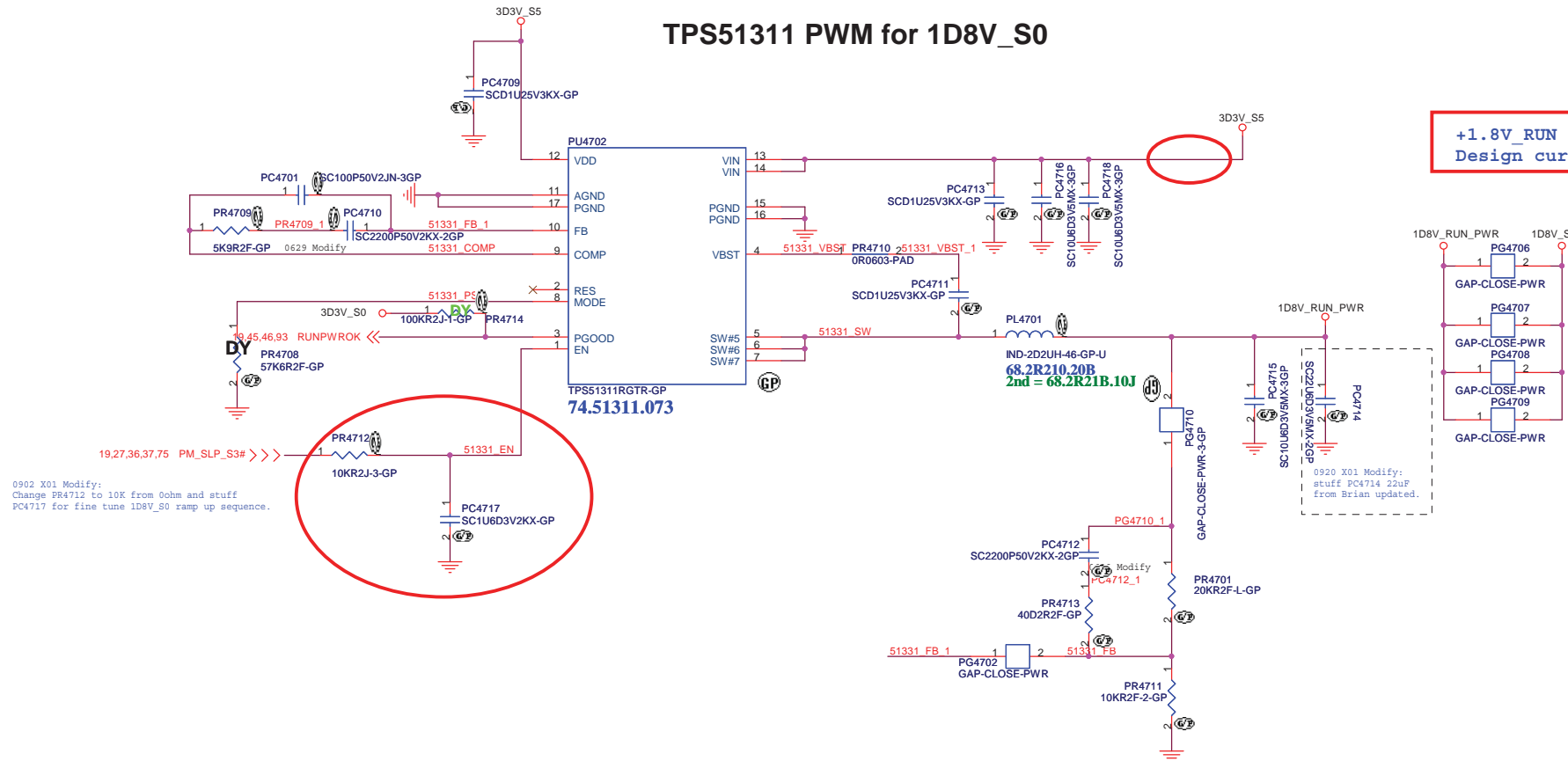

0902 X01 Modify:
Change PR4712 to 10K from 0ohm and stuff
PC4717 for fine tune 1D8V_S0 ramp up sequence.

0920 X01 Modify:
stuff PC4714 22uF
from Brian updated.

TPS51461 for VCCSA

1112 X02 Modify:
set TPS51461 PWR solution dummy field for
VCCSA_PWR and APL5916 LDO solution dummy
field for VCCSA_LDO. default stuff VCCSA_LDO at
GP stage.

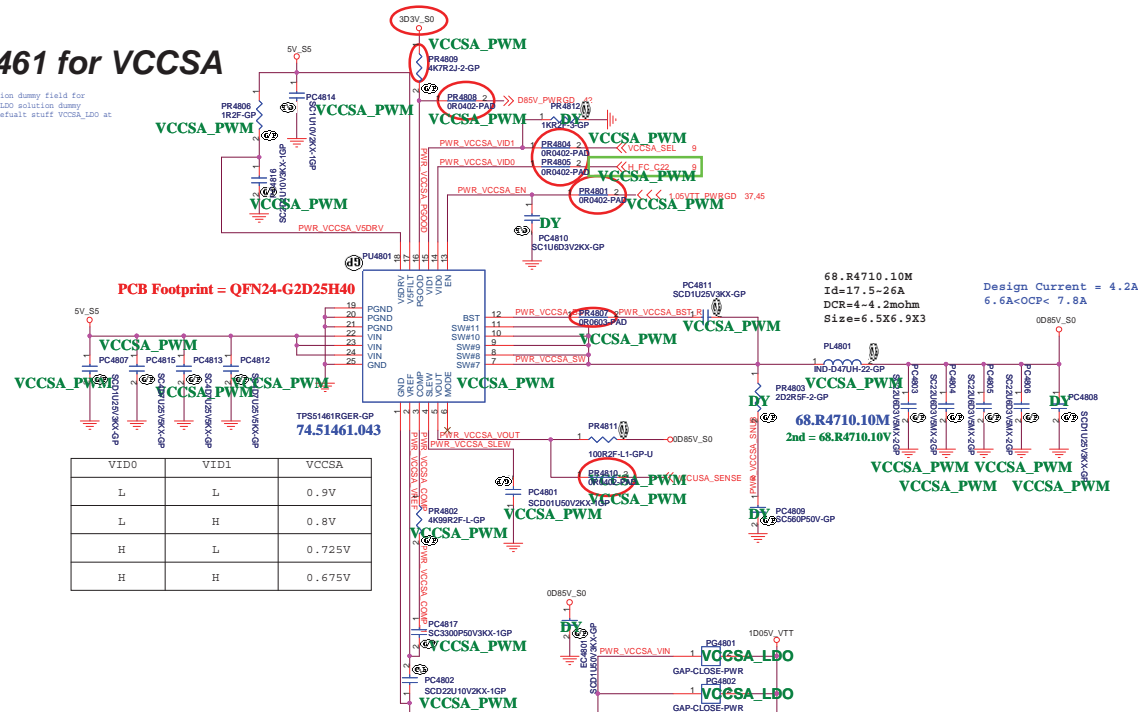

APL5916 for VCCSA

1112 X02 Modify:
CO-LAY APL5916 related circuit for VCCSA LDO
solution.

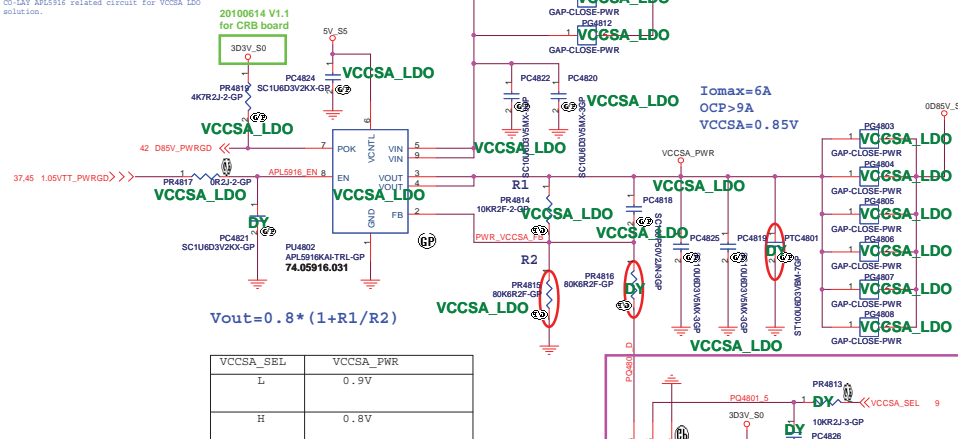

1118 X02 Modify:
Change PTC4801 to 100u(77.21071.07L)
from 150u from power team Brian updated.
1122 X02 Modify:
Updated VCCSA_LDO circuit from Power
team Brian updated.

<Core Design>



File			TPS51461 VCCSA		
Size	Document Number	Rev			
K2	QUEEN&NIRVANA 15	A00			
Date:	Tuesday, January 04, 2011	Sheet	48	of	108

SSID = VIDEO

0909 X01 Modify:
Change LCD1 to 20.F1816.030 for 30pin
Re-assign LCD1 pin define base on Roy updated
cable pin define list.

LVDS CONNECTOR

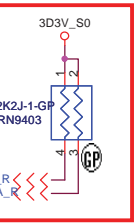
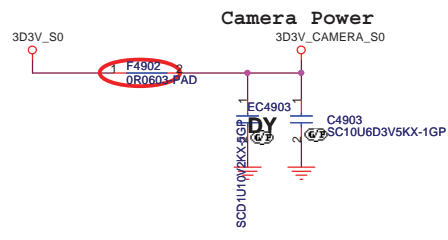
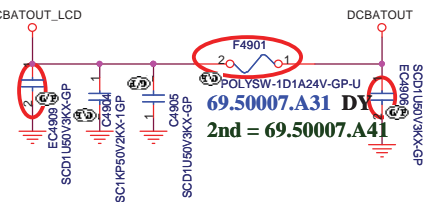
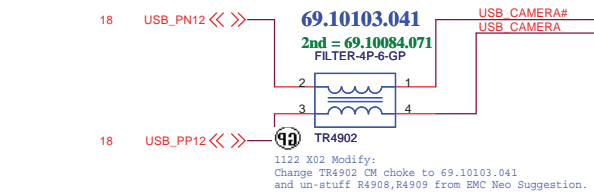
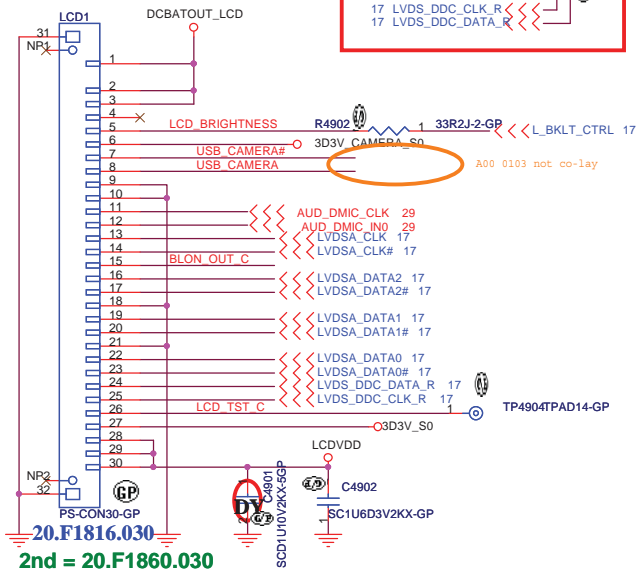

(MB Pin Define)	
MB CONN. (WIRE)	
Pin 1	DCBATOUT_LCD
Pin 2	DCBATOUT_LCD
Pin 3	DCBATOUT_LCD
Pin 4	NC
Pin 5	LCD_BRIGHTNESS
Pin 6	3D3V_CAMERA_S0
Pin 7	USB_CAMERA#
Pin 8	USB_CAMERA
Pin 9	GND
Pin 10	GND
Pin 11	AUD_DMIC_CLK
Pin 12	AUD_DMIC_IN0
Pin 13	LVDSA_CLK
Pin 14	LVDSA_CLK#
Pin 15	BLON_OUT_C
Pin 16	LVDSA_DATA2
Pin 17	LVDSA_DATA2#
Pin 18	GND
Pin 19	LVDSA_DATA1
Pin 20	LVDSA_DATA1#
Pin 21	GND
Pin 22	LVDSA_DATA0
Pin 23	LVDSA_DATA0#
Pin 24	LVDS_DDC_DATA_R
Pin 25	LVDS_DDC_CLK_R
Pin 26	LCD_TST_C
Pin 27	3D3V_S0
Pin 28	LCDVDD
Pin 29	LCDVDD
Pin 30	LCDVDD

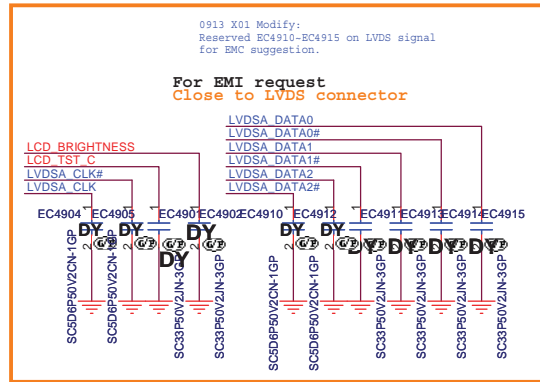

SSID = VIDEO

LCD POWER for ROSA

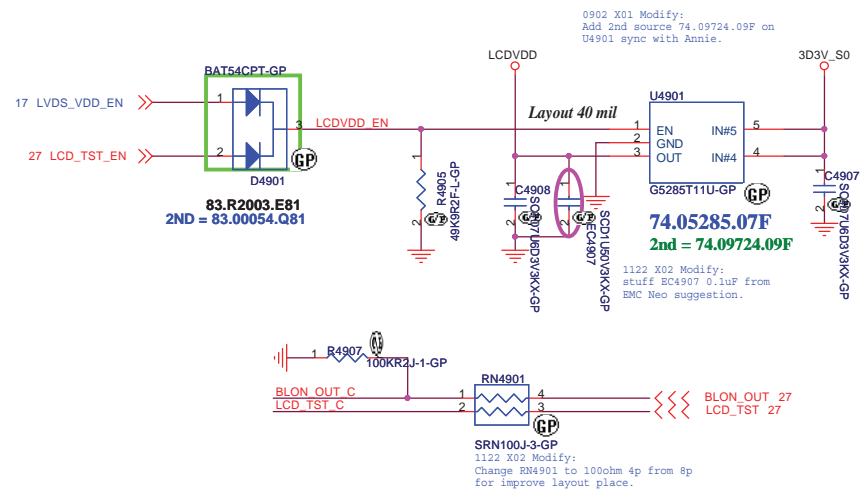

TOUCH PANEL

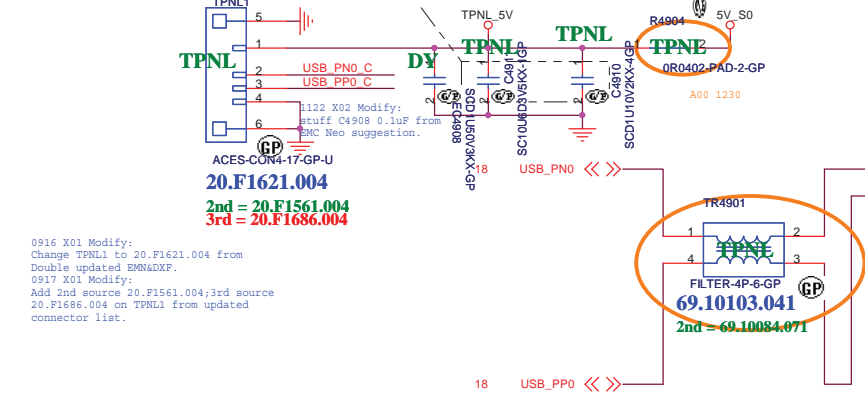

0916 X01 Modify:
Change TPNL1 to 20.F1621.004 from
Double updated EMN&DXF.
0917 X01 Modify:
Add 2nd source 20.F1561.004;3rd source
20.F1686.004 on TPNL1 from updated
connector list.

DN15ATI Whistler

Wistron Corporation
21F, 88, Sec.1, Hsin Tai Wu Rd., Hsichih,
Taipei Hsien 221, Taiwan, R.O.C.

File: **LCD Connector**

Size: A3 | Document Number: **QUEEN 15** | Rev: **A00**

Date: Tuesday, January 04, 2011 | Sheet: 49 of 108

(Blanking)

<Variant Name>

		Wistron Corporation 21F, 88, Sec.1, Hsin Tai Wu Rd., Hsichih, Taipei Hsien 221, Taiwan, R.O.C.
Title		
CRT Connector		
Size	Document Number	Rev
A3	QUEEN 15	A00
Date:	Tuesday, January 04, 2011	Sheet 50 of 108

SSID = VIDEO

HDMI Level Shifter & CONNECTOR

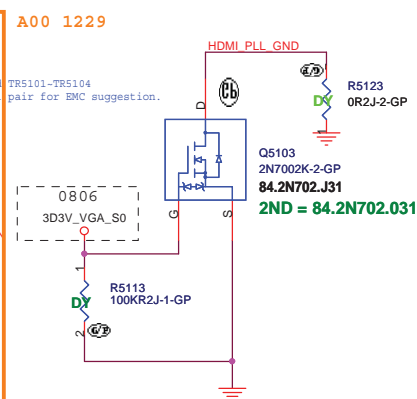
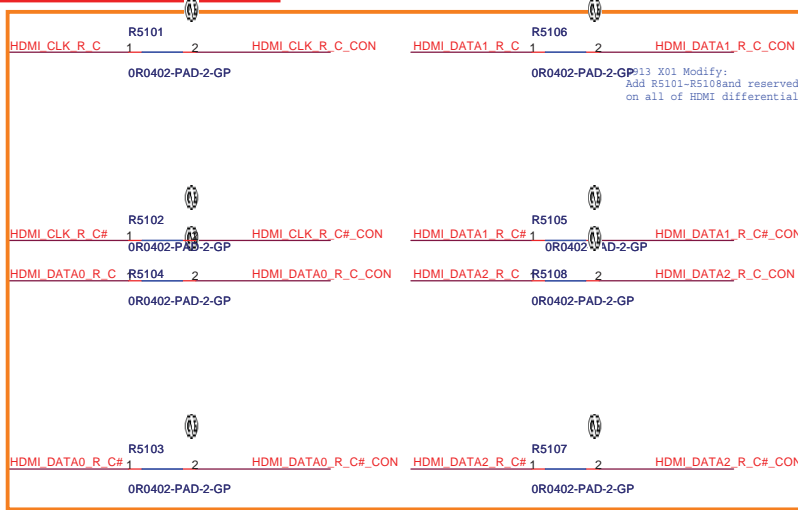

HDMI CONN

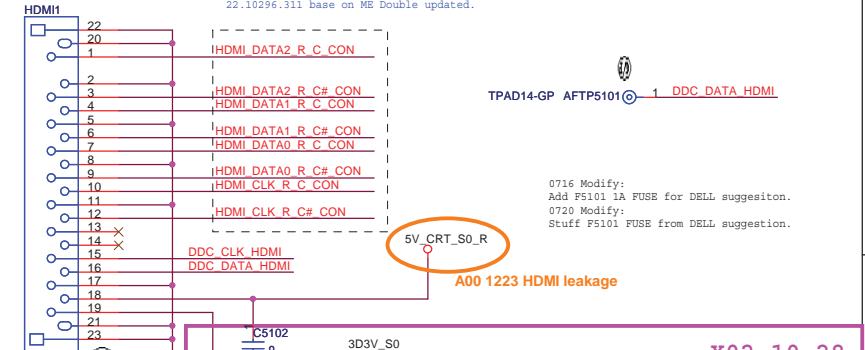

0721 Modify:
Change HDMI1 part number to 22.10296.271 from 22.10296.211 base on ME latest EMN and DXF.

0831 X01 Modify:
Change HDMI1 part number to 22.10296.311 from 22.10296.271 base on ME Double updated.

0910 X01 Modify:
Change HDMI1 part number to 22.10296.331 from 22.10296.311 base on ME Double updated.

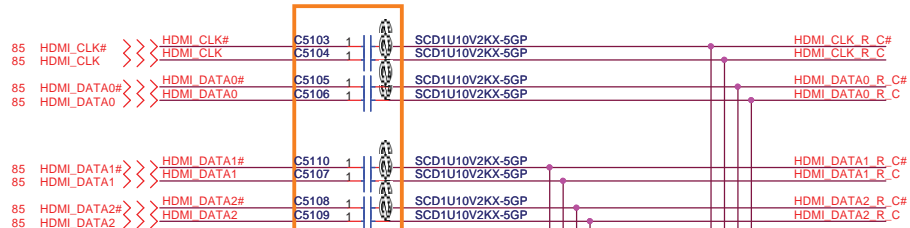

Close to HDMI Connector

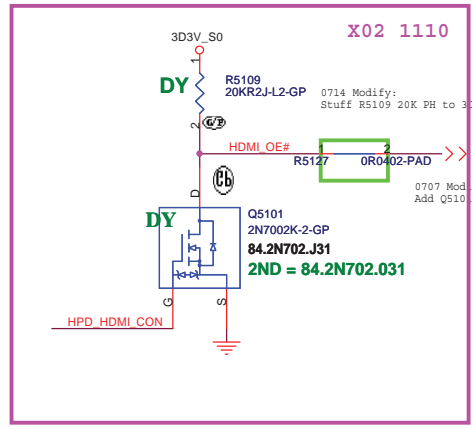

Routing Guidelines:
CTRLDATA must be routed longer than CTRLCLK within 1000 mils (25.4 mm).
The total delay on CTRLDATA should be longer than CTRLCLK.

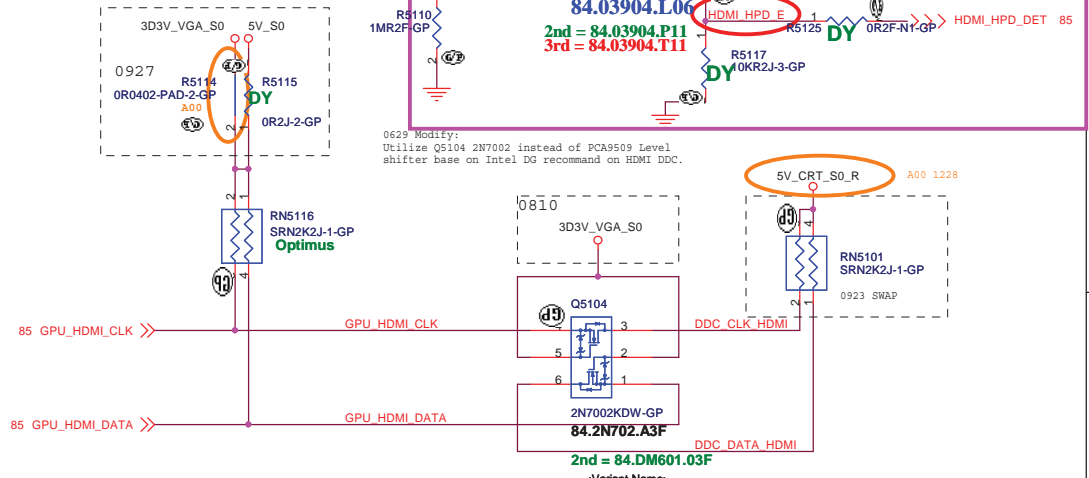

DELL Wistron Corporation
21F, 88, Sec.1, Hsin Tai Wu Rd., Hsichih, Taipei Hsien 221, Taiwan, R.O.C.

Title: **HDMI Level Shifter/Connector**

Size A3	Document Number	Rev
Date: Tuesday, January 04, 2011	QUEEN 15	A00
Sheet 51	of 108	

(Blanking)

<Core Design>

		Wistron Corporation 21F, 88, Sec. 1, Hsin Tai Wu Rd., Hsichih, Taipei Hsien 221, Taiwan, R.O.C.
Title		
Reserved		
Size A3	Document Number QUEEN 15	Rev A00
Date: Tuesday, January 04, 2011	Sheet 52 of	108

(Blanking)

<Core Design>



Title		
LVDS Switch		
Size	Document Number	Rev
A3	QUEEN 15	A00
Date:	Tuesday, January 04, 2011	Sheet 53 of 108

(Blanking)

<Core Design>

		Wistron Corporation 21F, 88, Sec. 1, Hsin Tai Wu Rd., Hsichih, Taipei Hsien 221, Taiwan, R.O.C.
Title		
Reserved		
Size A3	Document Number QUEEN 15	Rev A00
Date: Tuesday, January 04, 2011		Sheet 54 of 108

SSID = User.Interface

(Blanking)

<Core Design>



Title		
ITP/Fan Connector		
Size	Document Number	Rev
A3	QUEEN 15	A00
Date:	Tuesday, January 04, 2011	Sheet 55 of 108

SSID = SATA

SATA HDD Connector

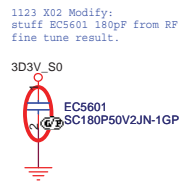
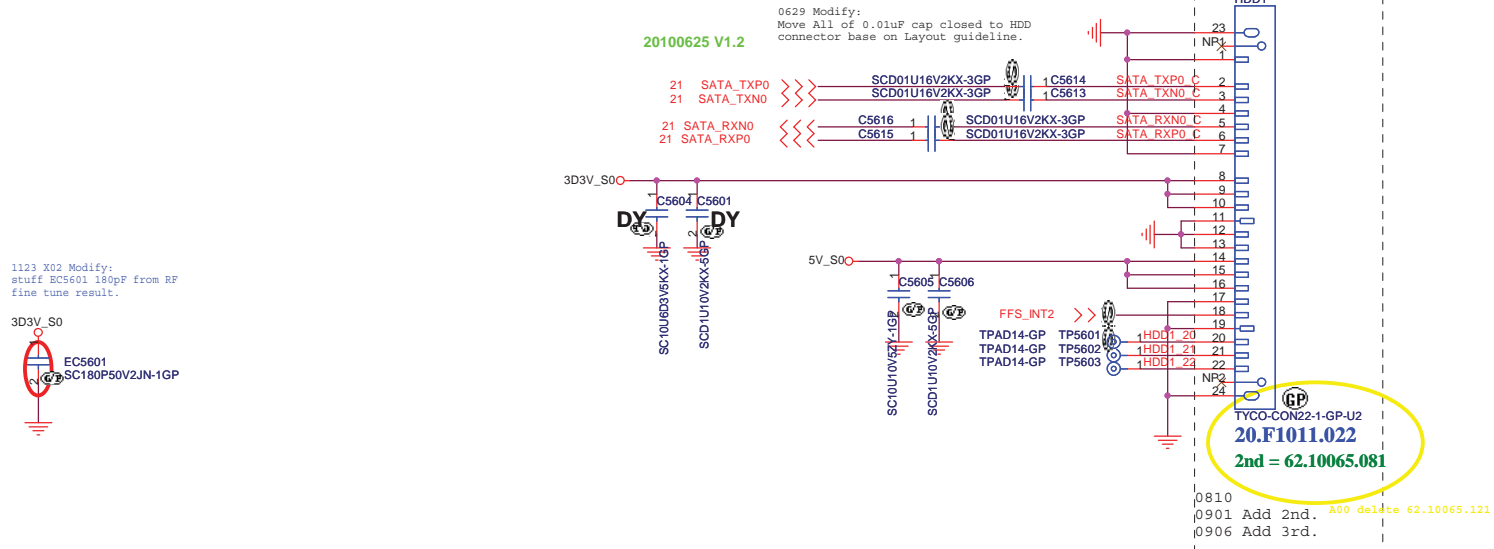

ODD Connector

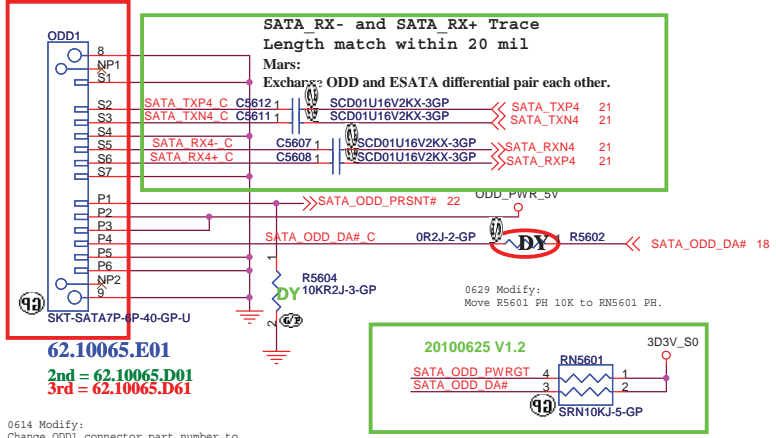

62.10065.E01
 2nd = 62.10065.D01
 3rd = 62.10065.D61

0614 Modify:
Change ODD1 connector part number to 22.10300.421 base on ME BMN and DXF.
 0707 Modify:
Change ODD1 connector part number to 62.10065.E01 base on latest BMN and DXF.

SUPPORT ZERO SATA ODD

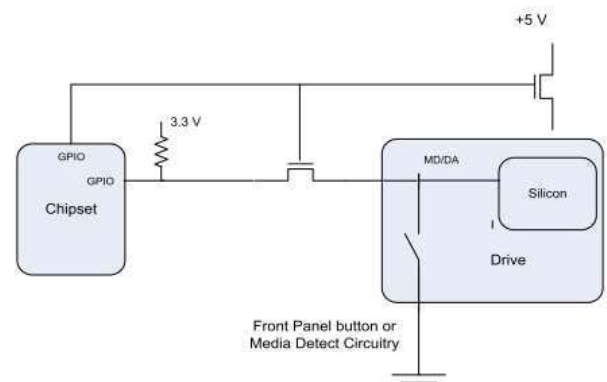

When the drive is powered on, the FET to the MD/DA pin drive is OFF.
 When the drive is powered off, the FET to the MD/DA pin is ON

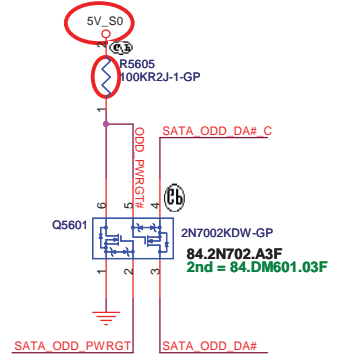

0707 Modify:
Change Q5601 to DUAL 2N7002 for isolate MD/DA signal between PCH and ODD.

SATA Zero Power ODD

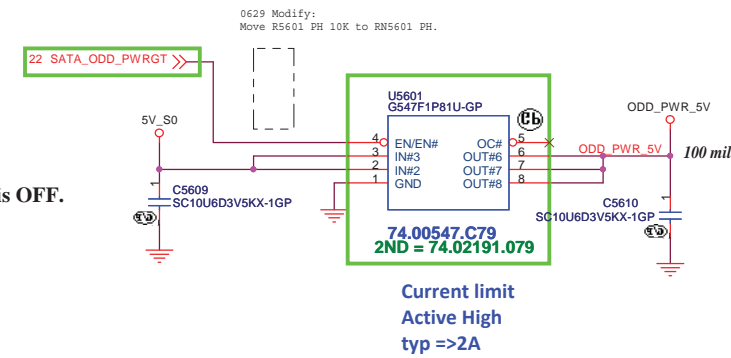

<Variant Name>

DELL Wistron Corporation
 21F, 88, Sec.1, Hsin Tai Wu Rd., Hsichih,
 Taipei Hsien 221, Taiwan, R.O.C.

Title: **HDD/ODD**

Size: A3 Document Number: **QUEEN 15** Rev: **A00**

Date: Tuesday, January 04, 2011 Sheet: 56 of 108

SSID = ESATA

USB CHARGER

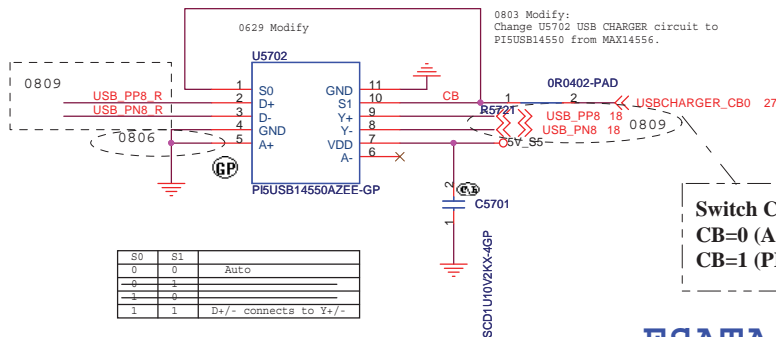

Switch Control Bit:
CB=0 (AM): auto detection charger identification active.
CB=1 (PM): connect DP/DM to TDP/TDM.

1122 X02 Modify:
 Change TR5701CM choke to 69.10103.041 and un-stuff R5718, R5719 from EMC Neo Suggestion.
 1123 X02 Modify:
 Change R5718, R5719 to 0603 from 0402.

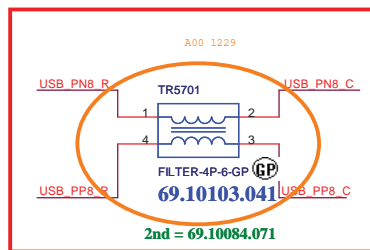

ESATA CONN

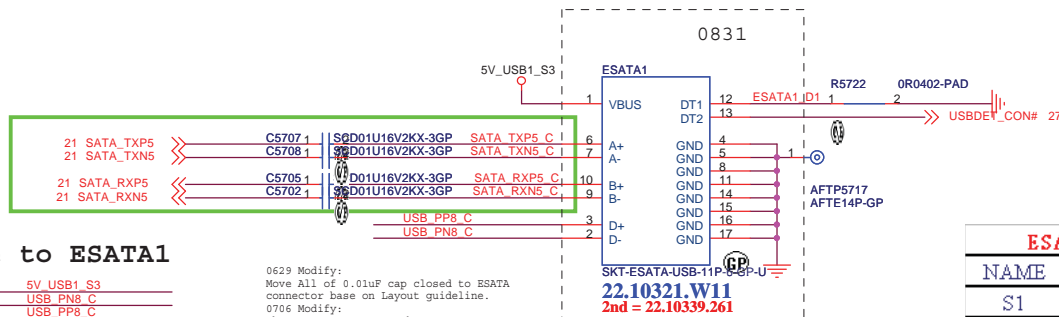

close to ESATA1

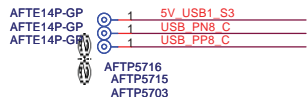

0629 Modify:
 Move All of 0.01uF cap closed to ESATA connector base on Layout guideline.
 0706 Modify:
 Change ESATA1 part number to 22.10321.F71 base on latest BMN and DXF.
 0713 Modify:
 Add USBDET_CON# on ESATA1 pin15 for USB temporary detect solution ESATA1 CONN should be searched for detect type connector.
 0719 Modify:
 ME Double provide temporary foxconn ESATA conn 22.10290.141 for SSI stage function test.

E-SATA USB 2.0 Combo
CE/H=-0.16/2.83mm with detect function

ESATA	
NAME	TYPE
S1	GND
S2	A+
S3	A-
S4	GND
S5	B-
S6	B+
S7	GND
USB	
NAME	TYPE
U1	VBUS
U2	D-
U3	D+
U4	GND

<Core Design>

DELL Wistron Corporation
 21F, 88, Sec. 1, Hsin Tai Wu Rd., Hsichih, Taipei Hsien 221, Taiwan, R.O.C.

Title ESATA		
Size A3	Document Number QUEEN 15	Rev A00
Date: Tuesday, January 04, 2011	Sheet 57 of 108	

SSID = AUDIO

Speaker Connector

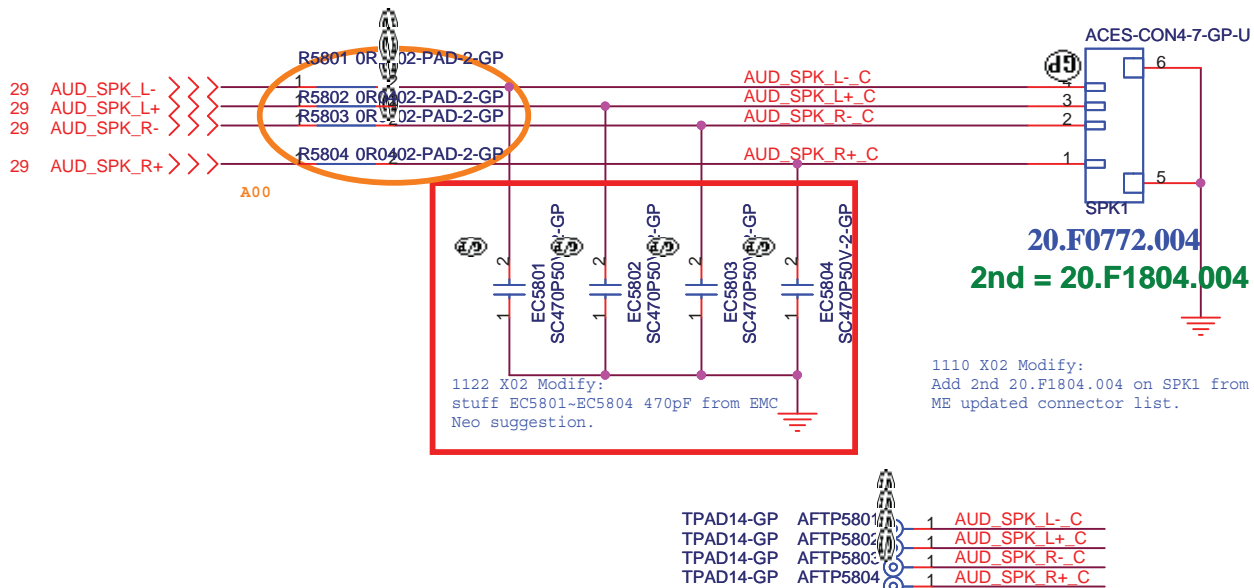

MB CONN. (WIRE)	
Pin 4	AUD_SPK_L-C
Pin 3	AUD_SPK_L+C
Pin 2	AUD_SPK_R-C
Pin 1	AUD_SPK_R+C

0913 X01 Modify:
 Change SPK1 to 20.F0772.004 from
 20.F1647.004 from Double updated.
 0914 X01 Modify:
 Re-assign SPK1 pin define base on
 Roy updated excel file for 20.F0772.004

1110 X02 Modify:
 Add 2nd 20.F1804.004 on SPK1 from
 ME updated connector list.

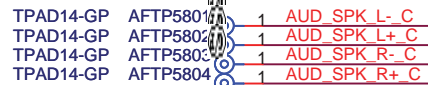

<Core Design>



Title		
SPEAKER CONN		
Size	Document Number	Rev
A4	QUEEN 15	A00
Date:	Tuesday, January 04, 2011	Sheet 58 of 108

(Blanking)

<Core Design>



Title **Reserved**

Size A3	Document Number QUEEN 15	Rev A00
------------	------------------------------------	-------------------

Date: Tuesday, January 04, 2011 Sheet 59 of 108

SSID = Flash.ROM

SPI FLASH ROM (4M byte) for PCH

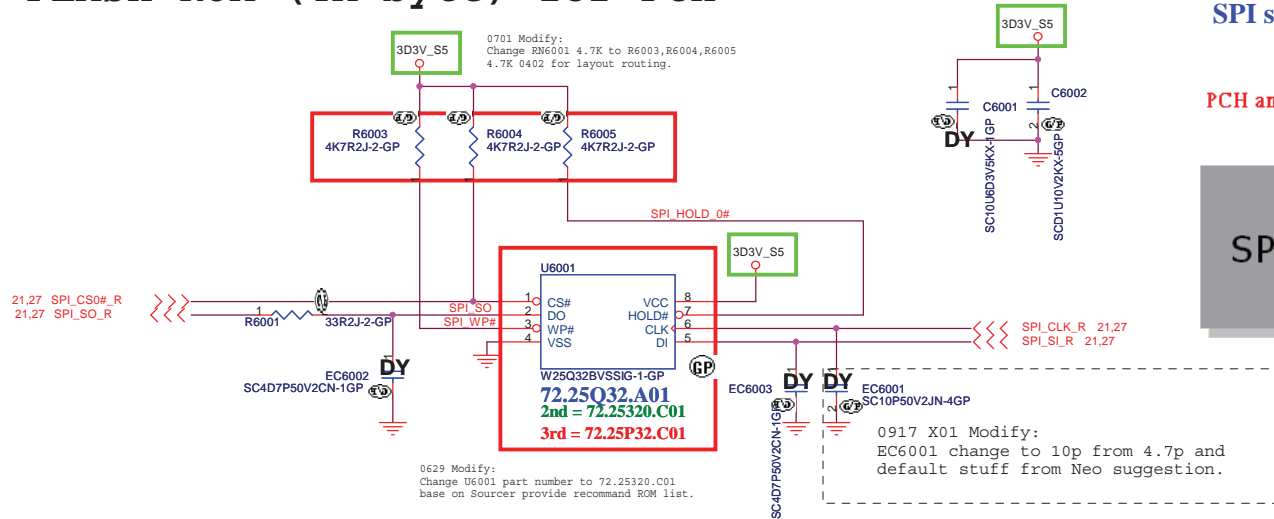

Notes:
The total SPI interface signal between EC and PCH can't not exceed 6500mil. The mismatch between SPI signal must be within 500mil

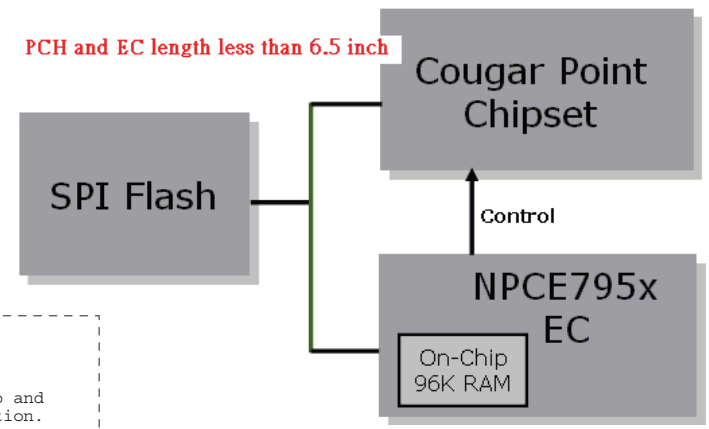

	Priority	Wistron P/N	Manufacturer	Vendor P/N
X02	1	72.25Q32.A01	WINBOND	W25Q32BVSSIG
	2	72.25320.C01	MXIC	MX25L3206EM2L-12G
X02	3	72.25P32.C01	Numonyx	M25PX32-VMW6F

SSID = RBATT

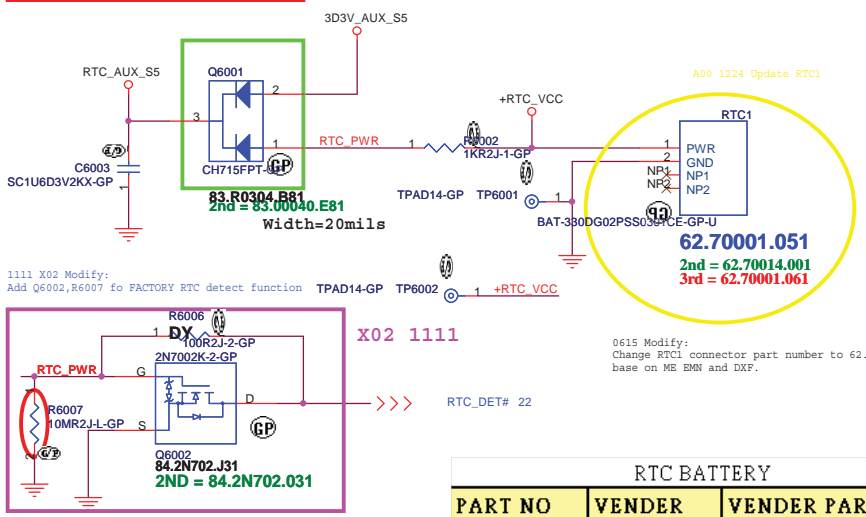

RTC BATTERY

PART NO	VENDER	VENDER PART NO.
23.20023.311	MITSUBISHI	CR2032 MITSUBISHI
23.20023.341	HENSHEN	CR-2032L/DBE
23.20068.001	KTS	BBBCR2032BX

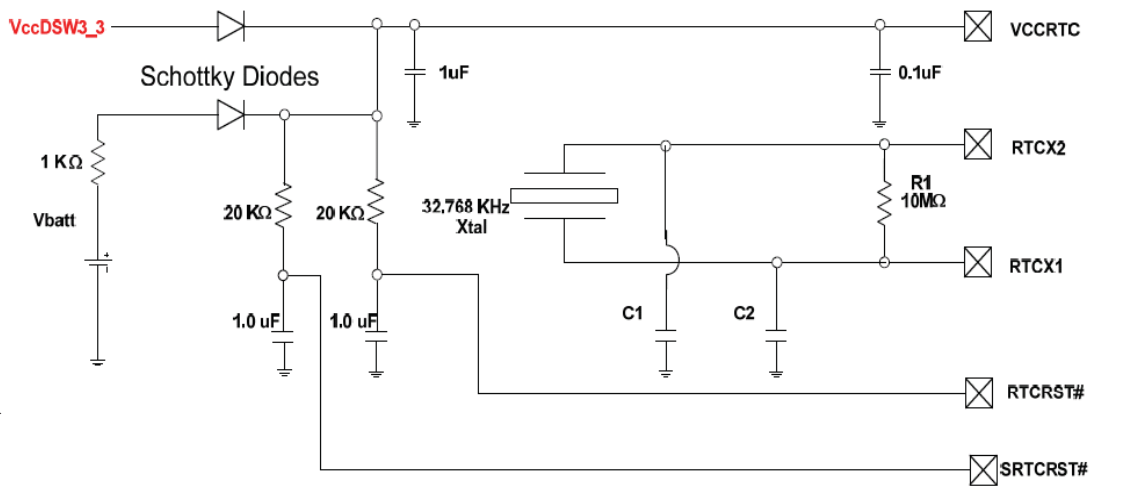

VccRTC is now connected to VccDSW3_3 through the Schottky diode instead of the 3.3V Sus well.

<Variant Name>

DELL Wistron Corporation
21F, 88, Sec.1, Hsin Tai Wu Rd., Hsichih, Taipei Hsien 221, Taiwan, R.O.C.

Title: **Flash/RTC**

Size A3 Document Number: **QUEEN 15** Rev: **A00**

Date: Tuesday, January 04, 2011 Sheet 60 of 108

SSID = USB

CRT Board and COMBO USB Power

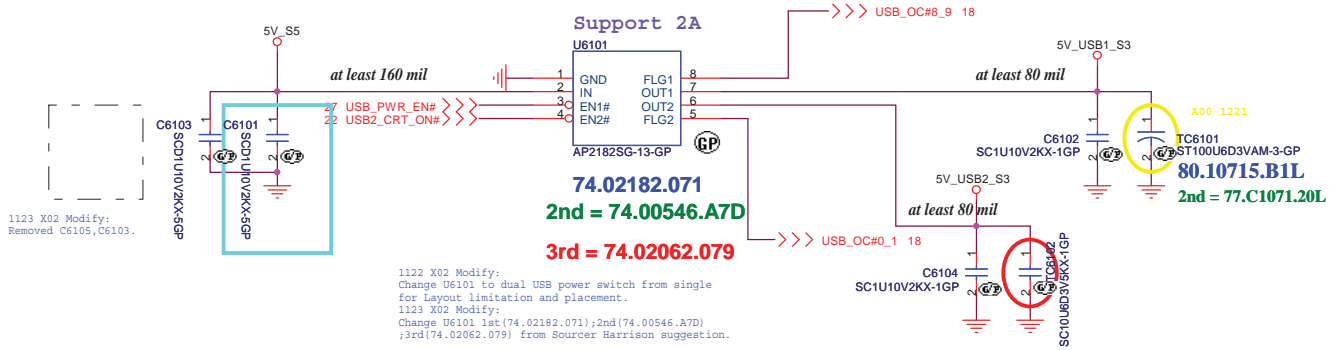

<Core Design>

DELL		Wistron Corporation	
		21F, 88, Sec.1, Hsin Tai Wu Rd., Hsichih, Taipei Hsien 221, Taiwan, R.O.C.	
Title			
USB Power SW			
Size	Document Number		Rev
	QUEEN&NIRVANA 15		A00
Date:	Tuesday, January 04, 2011	Sheet	61 of 108

(Blanking)

<Core Design>

		Wistron Corporation 21F, 88, Sec. 1, Hsin Tai Wu Rd., Hsichih, Taipei Hsien 221, Taiwan, R.O.C.
Title		
Reserved		
Size	Document Number	Rev
A3	QUEEN 15	A00
Date:	Tuesday, January 04, 2011	Sheet 62 of 108

SSID = User.Interface

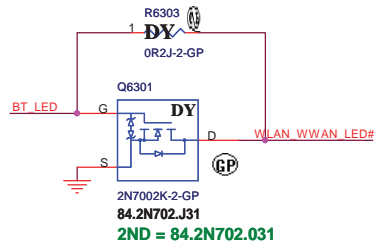

0722 Modify:
Add Q6301 and combine BT_LED to
WLAN_WWAN_LED#.

Bluetooth Module conn.

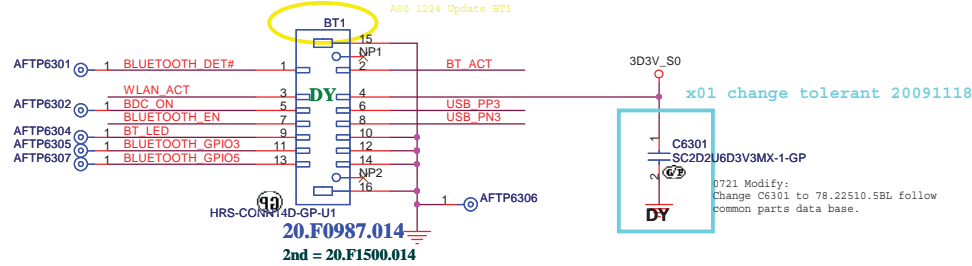

x01 change tolerant 20091118

0721 Modify:
Change C6301 to 78.22510.58L follow
common parts data base.

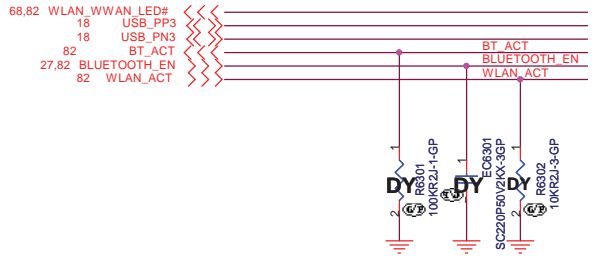

- AFTP6309 1 WLAN_ACT
- AFTP6310 1 BLUETOOTH_EN
- AFTP6308 1 BT_ACT
- AFTP6311 1 3D3V_S0
- AFTP6312 1 USB_PP3
- AFTP6313 1 USB_PN3

0709 Modify:
PM confirmed there is no stand-alone BT module,
so DF BT1 connector, add BT enable signal
and 5V_S5 power option on WLAN connector pin 51.
0712 Modify:
Stuff BT relatek component to verify function.

<Core Design>

Wistron Corporation
21F, 88, Sec.1, Hsin Tai Wu Rd., Hsichih,
Taipei Hsien 221, Taiwan, R.O.C.

Title: **Bluetooth**

Size: A3	Document Number: QUEEN 15	Rev: A00
Date: Tuesday, January 04, 2011	Sheet: 63	of: 108

Finger Printer Connector

0707 Modify:
 Add FP_DET# signal on FP1 pin1.
 0715 Modify:
 Add FP_DET# signal on FP1 pin1.
 0806 Swap pin.
 0810 Change to 4 pin.
 0827 Change to 6 pin.

1123 X02 Modify:
 Add C6402 0.1uF, C6403 180pF and stuff C6401
 47pF from RF fine tune result.

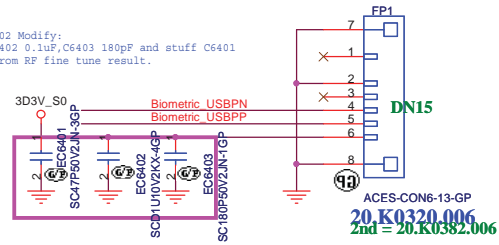

MB CONN.(FFC)	
Pin1	NC
Pin2	GND
Pin3	NC
Pin4	Biometric_USBPN
Pin5	Biometric_USBPP
Pin6	3D3V_S0

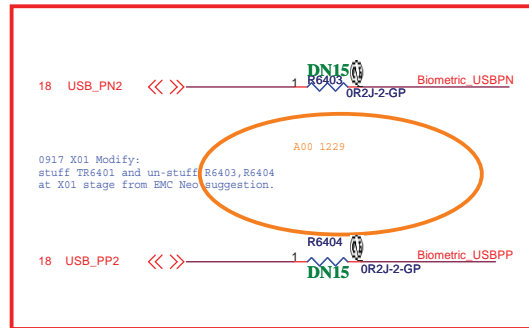

0917 X01 Modify:
 stuff TR6401 and un-stuff R6403, R6404
 at X01 stage from EMC Neo suggestion.

- AFTP42 1 3D3V_S0
- AFTP43 1 Biometric_USBPN
- AFTP44 1 Biometric_USBPP

0615 Modify:
 Change FP1 connector part number to 20.K0320.004
 base on ME EMN and DXF.
 0630 Modify:
 Change FP1 connector part number to 20.K0320.006
 base on ME EMN and DXF.
 0707 Modify:
 Reassign Finger print pin define base on EXCEL FILE.
 0713 Modify:
 Reassign Finger print pin define base on EXCEL FILE.
 Removed FP_DET# on FP1.

<Core Design>

DELL		Wistron Corporation	
		21F, 88, Sec.1, Hsin Tai Wu Rd., Hsichih, Taipei Hsien 221, Taiwan, R.O.C.	
Title			
RESERVED			
Size	Document Number	Rev	
A3	QUEEN 15	A00	
Date: Tuesday, January 04, 2011	Sheet	64	of 108

(Blanking)

<Core Design>

		Wistron Corporation 21F, 88, Sec. 1, Hsin Tai Wu Rd., Hsichih, Taipei Hsien 221, Taiwan, R.O.C.
Title		
RESERVED		
Size	Document Number	Rev
A3	QUEEN 15	A00
Date: Tuesday, January 04, 2011	Sheet 65 of	108

(Blanking)

<Core Design>



Title **Reserved**

Size A3	Document Number QUEEN 15	Rev A00
------------	------------------------------------	-------------------

Date: Tuesday, January 04, 2011 Sheet 66 of 108

(Blanking)

<Core Design>



Title **Reserved**

Size A3	Document Number QUEEN 15	Rev A00
Date: Tuesday, January 04, 2011		Sheet 67 of 108

SSID = User.Interface

FRONT POWER LED

Need change to LOW acted from KBC GPIO

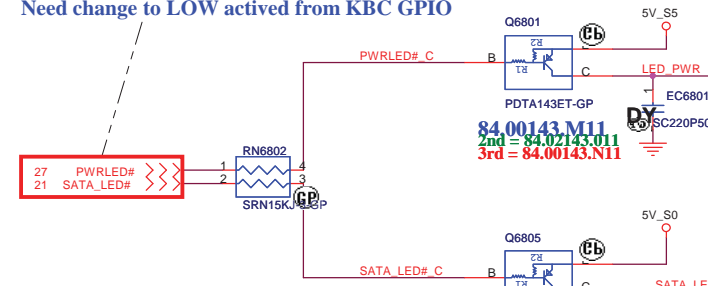

NEED confirm with ME actual FPOWER_LED part number.

0706 Modify:
Change FPOWER_LED part number to 83.01221.R70 base on latest EMN and DXF.

WLAN_LED

0706 Modify:
WLAN_LED# rename to WLAN_WWAN_LED#.

63.82 WLAN_WWAN_LED# >>>

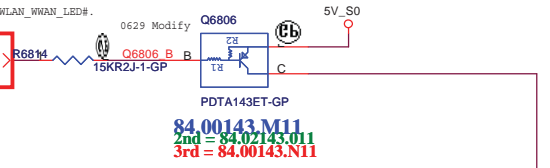

NEED confirm with ME actual HDD_LED part number.

0706 Modify:
Change HDD_LED part number to 83.01221.R70 base on latest EMN and DXF.

SATA HDD LED(White)

84.00143.M11
2nd = 84.02143.011
3rd = 84.00143.N11

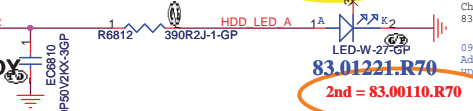

83.01221.R70
2nd = 83.00110.R70

0923 X01 Modify:
Add 2nd source 83.00110.J70 on FPOWERLED1, WLED1, WLANLED1 from Sourcer Anya suggestion.

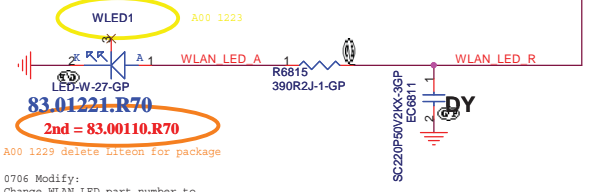

83.01221.R70
2nd = 83.00110.R70

NEED confirm with ME actual HDD_LED part number.

0706 Modify:
Change WLAN_LED part number to 83.01221.R70 base on latest EMN and DXF.

Battery LED2 (WHITE_LED)

Need change to LOW acted from KBC GPIO

0702 Modify:
Rename CHARGE_LED# to CHG_AMBER_LED#
Rename DC_BATFULL# to BATT_WHITE_LED#

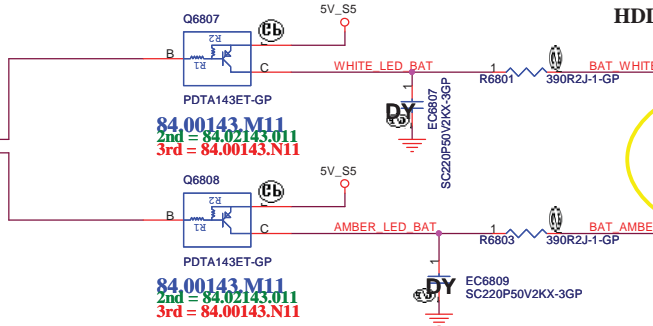

83.01222.X80
2nd = 83.00327.D70

A00 delete 83.01108.070

0923 X01 Modify:
Add 2nd source 83.00327.D70 on CHARGERLED1 from Sourcer Anya suggestion.

Battery LED1 (AMBER_LED)

Need change to LOW acted from KBC GPIO

TPLOCK LED

Need change to LOW acted from KBC GPIO



NEED confirm with ME actual HDD_LED part number.

0706 Modify:
Add PWRBTN2 from DQ15, PWRBTN1 FOR DN15.

SKEW	ITEM1	ITEM2
DQ15	PWRBTN1	TP_LOCK_LED1
DN15	PWRBTN2	TP_LOCK_LED2

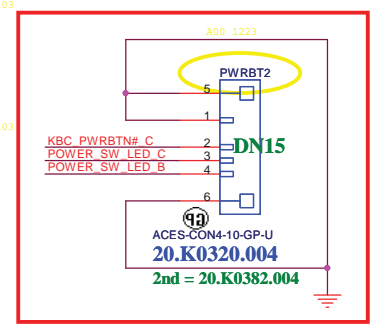

83.01921.P70
2nd = 83.00190.S7A

83.01921.P70
2nd = 83.00190.S7A

83.01921.P70
2nd = 83.00190.S7A

NEED confirm with ME actual HDD_LED part number.

83.01921.P70
2nd = 83.00190.S7A

83.01921.P70
2nd = 83.00190.S7A

83.01921.P70
2nd = 83.00190.S7A



NEED confirm with ME actual HDD_LED part number.

83.01921.P70
2nd = 83.00190.S7A

83.01921.P70
2nd = 83.00190.S7A

83.01921.P70
2nd = 83.00190.S7A

83.01921.P70
2nd = 83.00190.S7A

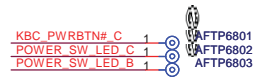

20.K0320.004
2nd = 20.K0382.004

ACES-C0N4-10-GP-U
20.K0320.004
2nd = 20.K0382.004

0715 Modify:
Removed PWR_BTN_LED# control circuit base on Dell feedback.

<Core Design>



Title LED Bard/Power Button		
Size A3	Document Number QUEEN 15	Rev A00
Date: Tuesday, January 04, 2011	Sheet 68	of 108

SSID = KBC

Internal Keyboard Connector

0630 Modify:
Change KB1 part number to 20.K0565.030
base on ME updated EMN and DXF.

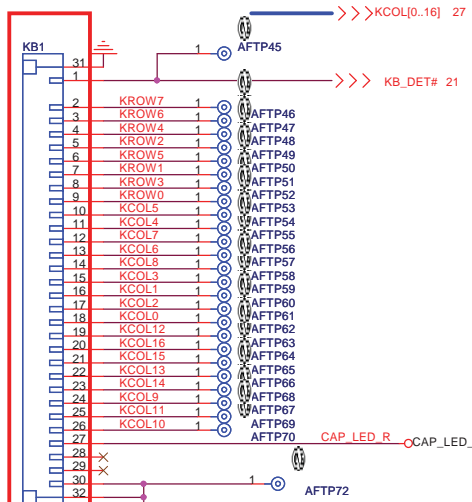

MB Pin	Description
1	Diag_Loop3 = GPIO_1 (TPC)
2	KSI[7] = KBD S8
3	KSI[6] = KBD S7
4	KSI[4] = KBD S5
5	KSI[2] = KBD S3
6	KSI[5] = KBD S6
7	KSI[1] = KBD S2
8	KSI[3] = KBD S4
9	KSI[0] = KBD S1
10	KSO[5] = KBD D6
11	KSO[4] = KBD D5
12	KSO[7] = KBD D8
13	KSO[6] = KBD D7
14	KSO[8] = KBD D9
15	KSO[3] = KBD D4
16	KSO[1] = KBD D2
17	KSO[2] = KBD D3
18	KSO[0] = KBD D1
19	KSO[12] = KBD D13
20	KSO[16] = KBD D17
21	KSO[15] = KBD D16
22	KSO[13] = KBD D14
23	KSO[14] = KBD D15
24	KSO[9] = KBD D10
25	KSO[11] = KBD D12
26	KSO[10] = KBD D11
27	NC (reserved for Caps LK LED)
28	NC (reserved for Num LK LED)
29	NC (reserved for Scroll LK LED)
30	GND

CAP LED CONTROL

High Active from KBC GPIO.

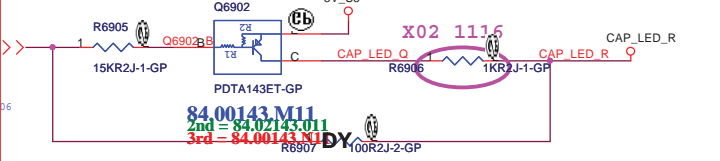

84.00143.M11
2nd = 84.02143.011
3rd = 84.00143.011

KB Backlight Connector

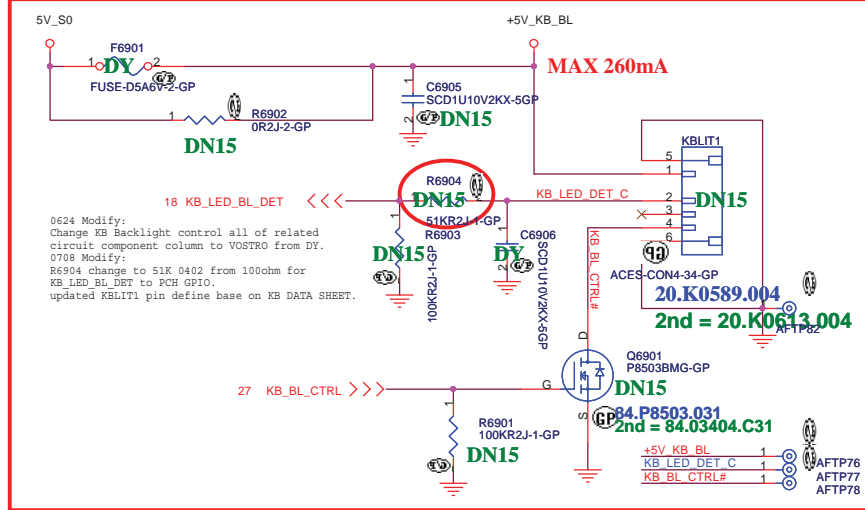

0624 Modify:
Change KB Backlight control all of related
circuit component column to VOSTRO from DY.
0708 Modify:
R6904 change to 51K 0402 from 100ohm for
KB_LED_DET to PCH GPIO.
updated KBLIT1 pin define base on KB DATA SHEET.

SSID = Touch.Pad

TouchPad Connector

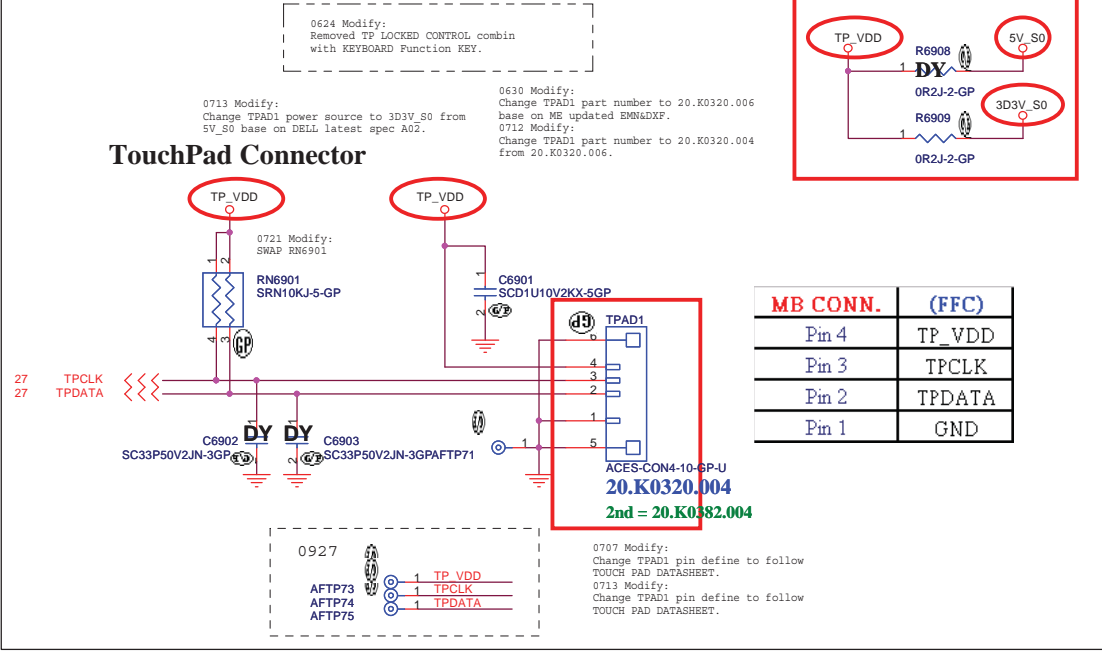

0715 Modify:
Add R6908, R6909 for TPAD1 co-layer power option.

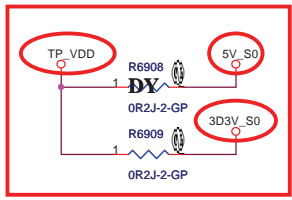

MB CONN.	(FFC)
Pin 4	TP_VDD
Pin 3	TPCLK
Pin 2	TPDATA
Pin 1	GND

SKEW	OPTION1	OPTION2	PIN	Feature	REMARK
DQ13	C12S		30		S is mean small
DN13	C12S	C12SB	30/25	Backlight	SB is mean small with backlight
DN15	C12S	C12SB	30/25	Backlight	
DQ15	C12SN		30	KB_DET#,CAP LED	SN is mean small with numpad

MB CONN. (FFC)	
Pin 1	+5V_KB_BL
Pin 2	KB_LED_DET_C
Pin 3	NC
Pin 4	KB_BL_CTRL#

0901 X01 Modify:
Change KBLIT1 to 20.K0320.004 from
20.K0218.004 base on ME updated X01 DXF&EMN.
Re-assign KBLIT1 pin define sync with DQ15_NV.
0914 X01 Modify:
Add 2nd source 20.K0382.004 on KBLIT1
base on updated connector list.
0923 X01 Modify:
Change KBLIT1 part number to 20.K0589.004
and re-assign pin define base on Roy updated.

<Core Design>

DELL Wistron Corporation
21F, 88, Sec. 1, Hsin Tai Wu Rd., Hsichih,
Taipei Hsien 221, Taiwan, R.O.C.

Title: **Key Board/Touch Pad**

Size A3 Document Number: **QUEEN 15** Rev: **A00**

Date: Tuesday, January 04, 2011 Sheet 69 of 108

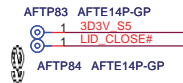
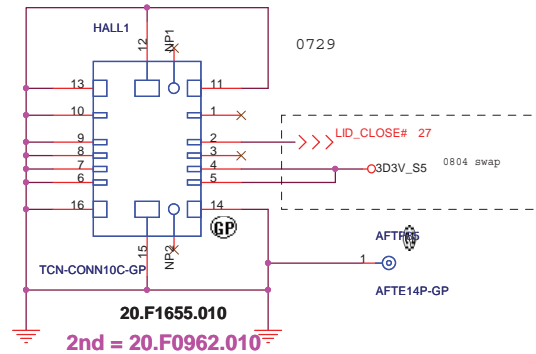

1110 X02 Modify:
Add 2nd 20.F0962.010 on HALL1 from
ME updated connector list.

<Core Design>

DELL		Wistron Corporation	
		21F, 88, Sec.1, Hsin Tai Wu Rd., Hsichih, Taipei Hsien 221, Taiwan, R.O.C.	
Title			
Hall Sensor			
Size	Document Number	Rev	
A3	QUEEN 15	A00	
Date:	Tuesday, January 04, 2011	Sheet	70 of 108

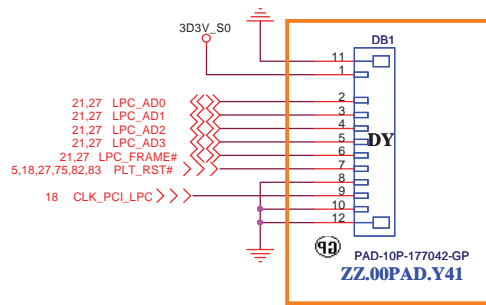

A00 1229 DB1 change to ZZ.00PAD.Y41(solder kmask type)
and keep un-stuffat X-Build stage

<Core Design>

DELL		Wistron Corporation	
		21F, 88, Sec.1, Hsin Tai Wu Rd., Hsichih, Taipei Hsien 221, Taiwan, R.O.C.	
Title			
Dubug connector			
Size A3	Document Number	Rev	
	QUEEN 15	A00	
Date: Tuesday, January 04, 2011	Sheet 71	of	108

(Blanking)

<Core Design>



Title **Reserved**

Size A3	Document Number QUEEN 15	Rev A00
Date: Tuesday, January 04, 2011		Sheet 72 of 108

(Blanking)

<Core Design>



Title **Reserved**

Size A3	Document Number QUEEN 15	Rev A00
------------	------------------------------------	-------------------

Date: Tuesday, January 04, 2011 Sheet 73 of 108

SSID = SDIO

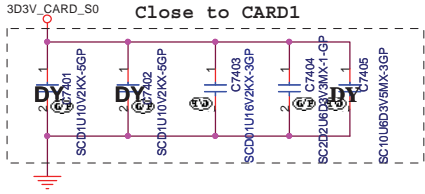

SD/XD/MS/MMC+ Card Reader

0906 X01 Modify:
Change CARD1 to 20.10129.001 from 62.10051.931
from MS double updated latest DXF&MN on X01.

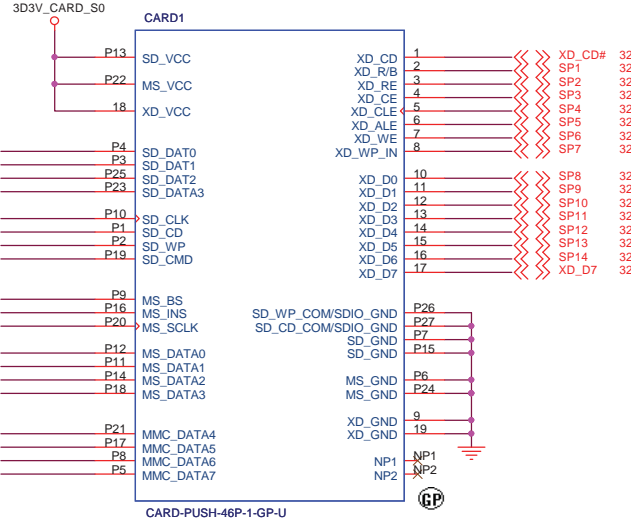

20.10129.001

2nd = 20.10135.001

1119 X02 Modify:
Add 2nd 20.10135.001 on HALL1 from
ME updated connector list.

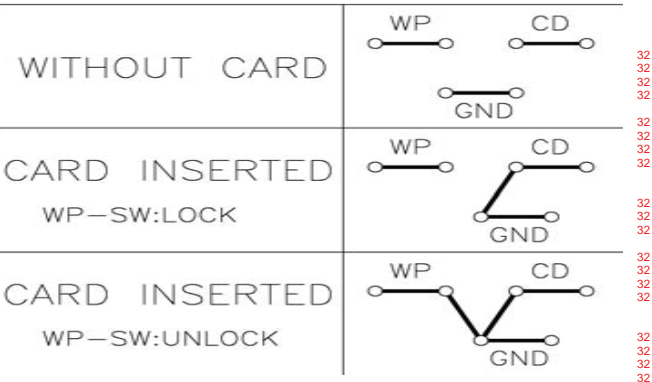

For EMI Reserved

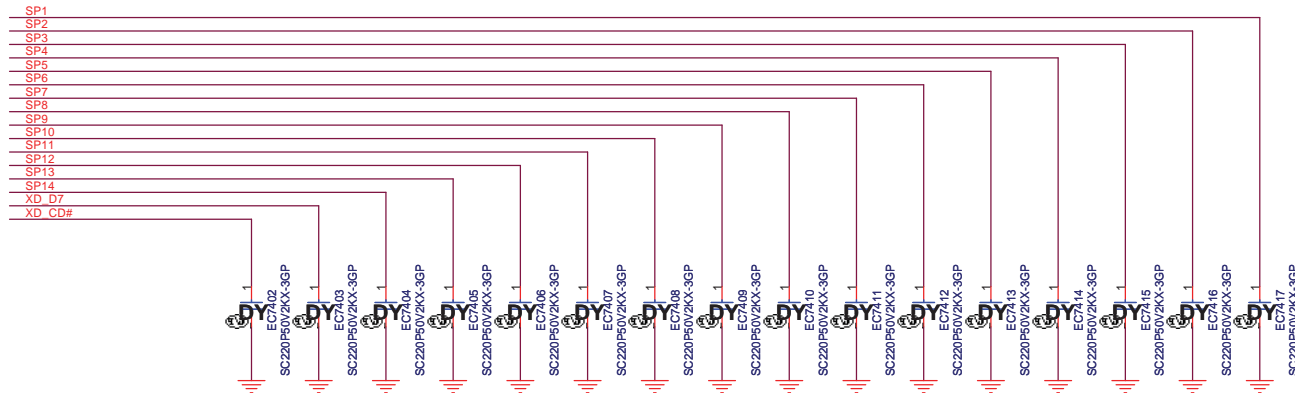

20.10129.001			
Pin	TYPE	FUNCTION	RTS5138 NET
P1	SD	SD-CD	SP6
P2	SD	SD-WP	SP1
P3	SD	SD-DAT1	SP3
P4	SD	SD-DAT0	SP4
P5	MMC_PLUS	MMC-DATA7	SP5
P6	MemoryStick	MS-GND	GND
P7	SD	SD-GND	GND
P8	MMC_PLUS	MMC-DATA6	SP7
P9	MemoryStick	MS-BS	SP14
P10	SD	SD-CLK	SP8
P11	MemoryStick	MS-DATA1	SP12
P12	MemoryStick	MS-DATA0	SP9
P13	SD	SD-VCC	3D3V_CARD_S0
P14	MemoryStick	MS-DATA2	SP8
P15	SD	SD-GND	GND
P16	MemoryStick	MS-INS	SP2
P17	MMC_PLUS	MMC-DATA5	SP9
P18	MemoryStick	MS-DATA3	SP5
P19	SD	SD-CMD	SP10
P20	MemoryStick	MS-SCLK	SP1
P21	MMC_PLUS	MMC-DATA4	SP11
P22	MemoryStick	MS-VCC	3D3V_CARD_S0
P23	SD	SD-DATA3	SP12
P24	MemoryStick	MS-GND	GND
P25	SD	SD-DAT2	SP13
P26	SD	SD-WP COM /SDIO GND	GND
P27	SD	SD-CD COM /SDIO GND	GND
#1	XD	XD-CD	XD_CD#
#2	XD	XD-R/B	SP1
#3	XD	XD-RE	SP2
#4	XD	XD-CE	SP3
#5	XD	XD-CLE	SP4
#6	XD	XD-ALE	SP5
#7	XD	XD-WE	SP6
#8	XD	XD-WP-IN	SP7
#9	XD	XD-GND	GND
#10	XD	XD-D0	SP8
#11	XD	XD-D1	SP9
#12	XD	XD-D2	SP10
#13	XD	XD-D3	SP11
#14	XD	XD-D4	SP12
#15	XD	XD-D5	SP13
#16	XD	XD-D6	SP14
#17	XD	XD-D7	XD-D7
#18	XD	XD-VCC	3D3V_CARD_S0
#19	XD	XD-GND	GND

<Core Design>

DELL Wistron Corporation
21F, 88, Sec. 1, Hsin Tai Wu Rd., Hsichih, Taipei Hsien 221, Taiwan, R.O.C.

Title: **SD/XD/MS/MMC Card CONN**

Size A3 Document Number **QUEEN 15** Rev **A00**

Date: Tuesday, January 04, 2011 Sheet 74 of 108

1122 X02 Modify:
 Change TR7501 CM choke to 69.10103.041
 and un-stuff R7501,R7502 from EMC Neo Suggestion.
 Change R7501,R7502 to 0603 from 0402.

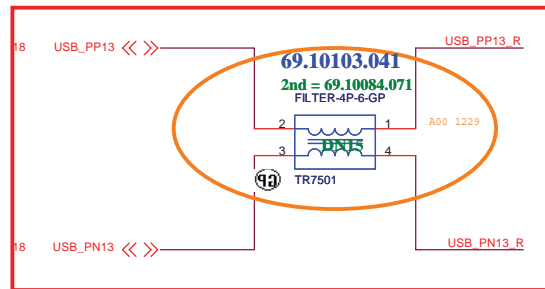

AFTE14P-GP AFTP107	1	3D3V_S5
AFTE14P-GP AFTP108	1	3D3V_S0
AFTE14P-GP AFTP109	1	1D5V_S0
AFTE14P-GP AFTP110	1	USB_PN13_R
AFTE14P-GP AFTP111	1	USB_PP13_R
AFTE14P-GP AFTP112	1	CLK_PCIE_NEW_REQ#_CON
AFTE14P-GP AFTP113	1	SMB_CLK
AFTE14P-GP AFTP114	1	SMB_DATA
AFTE14P-GP AFTP115	1	PM_SLP_S3#
AFTE14P-GP AFTP116	1	PM_SLP_S4#
AFTE14P-GP AFTP117	1	PLT_RST#
AFTE14P-GP AFTP118	1	CLK_PCIE_NEW#_C
AFTE14P-GP AFTP119	1	CLK_PCIE_NEW_C
AFTE14P-GP AFTP120	1	PCIE_TXN8_CON
AFTE14P-GP AFTP121	1	PCIE_TXP8_CON
AFTE14P-GP AFTP122	1	PCIE_RXN8_CON
AFTE14P-GP AFTP123	1	PCIE_RXP8_CON
AFTE14P-GP AFTP124	1	PCIE_WAKE#_CON

1D5V_S0_CARD Max. 650mA, Average 500mA.
 3D3V_S0_CARD Max. 1300mA, Average 1000mA
 3D3V_S5_CARDAUX Max. 275mA

0824 X01 Modify:
 Due to our NEW1 change to Express card to
 bottom side so re-assign NEW1 pin define same
 as DQ15-WY.
 0906 X01 Modify:
 Add 2nd source 20.K0382.026 on NEW1 base on
 updated connector list.

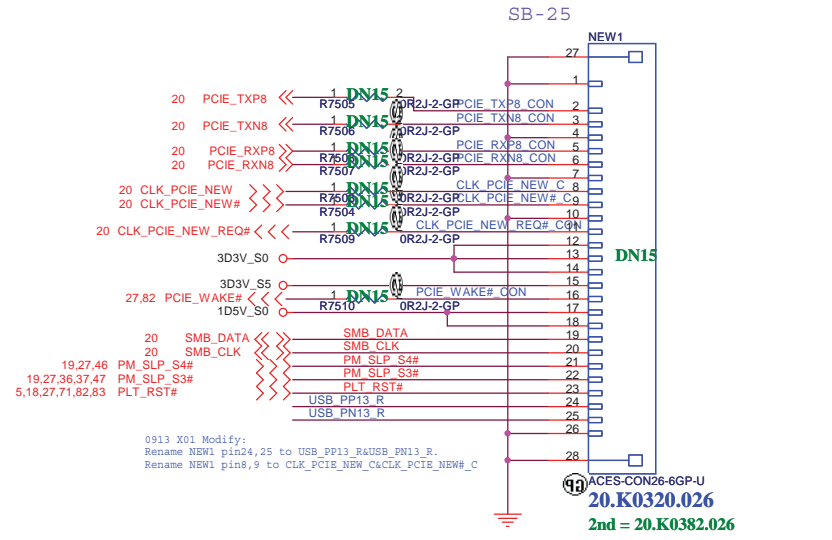

0913 X01 Modify:
 Rename NEW1 pin24,25 to USB_PP13_R&USB_PN13_R.
 Rename NEW1 pin8,9 to CLK_PCIE_NEW_C&CLK_PCIE_NEW#_C

For EMI

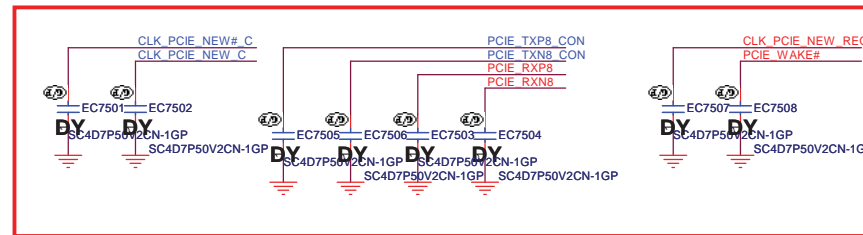

0913 X01 Modify:
 Add R7503,R7504 and reserved EC7501,EC7502 on
 CLK_PCIE_NEW & CLK_PCIE_NEW# for EMC suggestion.
 0921 X01 Modify:
 Add R7505-R7508 0ohm and reserved EC7503-EC7506
 on PCIE_TX8&RX8 signal base on EMC Lance suggestion.
 Add R7509,R7510 0ohm and reserved EC7507,EC7508
 on CLK_PCIE_NEW_REQ#&PCIE_WAKE# signal base
 on EMC Lance suggestion.

<Core Design>

DELL		Wistron Corporation	
		21F, 88, Sec.1, Hsin Tai Wu Rd., Hsichih, Taipei Hsien 221, Taiwan, R.O.C.	
Title			
Express Card			
Size	Document Number	Rev	
A3	QUEEN 15	A00	
Date:	Tuesday, January 04, 2011	Sheet	75 of 108

(Blanking)

<Core Design>

		Wistron Corporation 21F, 88, Sec. 1, Hsin Tai Wu Rd., Hsichih, Taipei Hsien 221, Taiwan, R.O.C.
Title		
Reserved		
Size	Document Number	Rev
A3	QUEEN 15	A00
Date:	Tuesday, January 04, 2011	Sheet 76 of 108

(Blanking)

<Core Design>



Title **Reserved**

Size A3	Document Number QUEEN 15	Rev A00
------------	------------------------------------	-------------------

Date: Tuesday, January 04, 2011 Sheet 77 of 108

(Blanking)

<Core Design>



Title		
Reserved		
Size	Document Number	Rev
A3	QUEEN 15	A00
Date:	Tuesday, January 04, 2011	Sheet 78 of 108

Free Fall Sensor

Note

- no via, trace, under the sensor (keep out area around 2mm)
- stay away from the screw hole or metal shield soldering joints
- design PCB pad based on our sensor LGA pad size (add 0.1mm)
- solder stencil opening to 90% of the PCB pad size
- mount the sensor near the center of mass of the NB as possible as you can

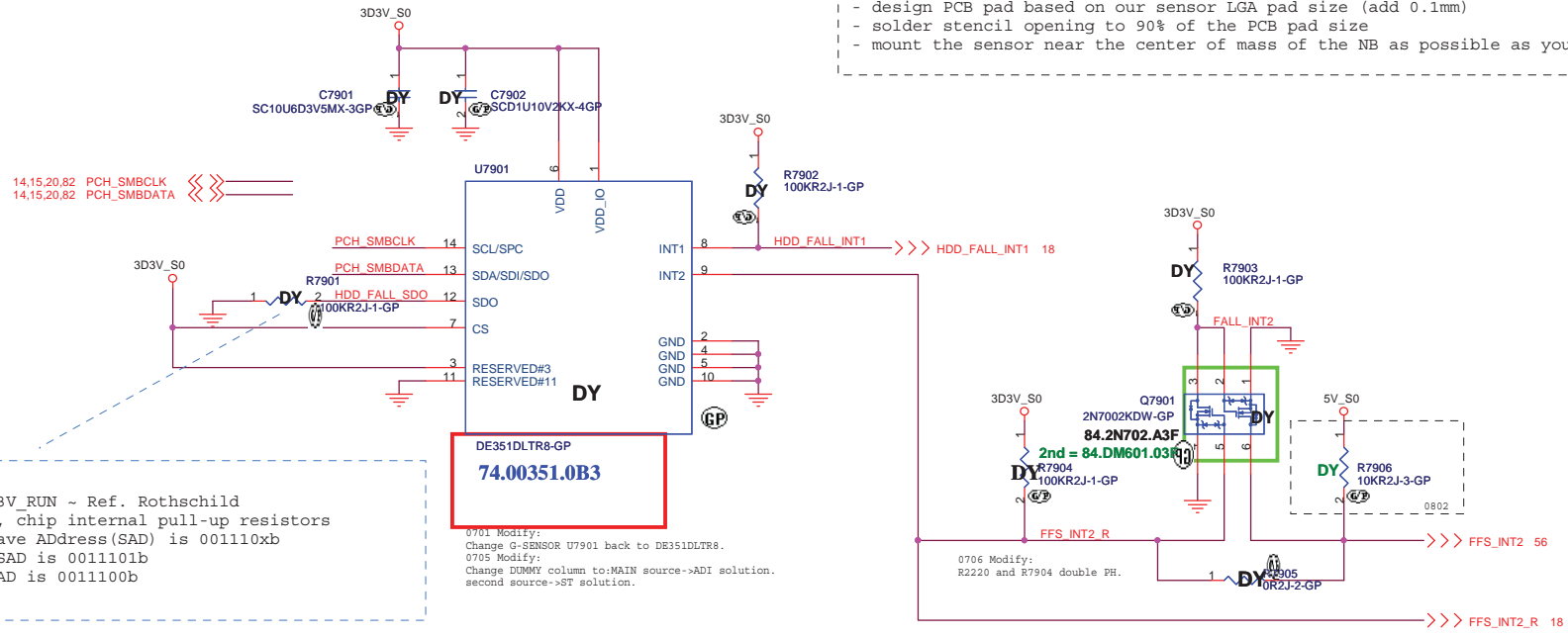

09/0422
 (#1) Just pull +3.3V_RUN ~ Ref. Rothschild
 (#2) FAE/ DY is ok, chip internal pull-up resistors
 (#3) From spec, Slave Address(SAD) is 001110xb
 Pull HIGH SAD is 0011101b
 Pull GND SAD is 0011100b

0701 Modify:
 Change G-SENSOR U7901 back to DE351DLTR8.
 0705 Modify:
 Change DUMMY column to:MAIN source->ADI solution.
 second source->ST solution.

Note

- (1) Keep all signals are the same trace width. (included VDD, GND).
- (2) No VIA under IC bottom.

(Blanking)

<Core Design>



Title **Reserved**

Size A3	Document Number QUEEN 15	Rev A00
------------	------------------------------------	-------------------

Date: Tuesday, January 04, 2011 Sheet 80 of 108

(Blanking)

<Core Design>



Title **Reserved**

Size A3	Document Number QUEEN 15	Rev A00
------------	------------------------------------	-------------------

Date: Tuesday, January 04, 2011 Sheet 81 of 108

IO Board CONN 80 pin

1122 X01 Modify:
Dell required us to disable PCIE port of WWAN slot
, If PCIE port 1 is disabled, it will cause all PCIE port
disabled, so change WWAN to PCIE port 3 from port1
at ST stage.

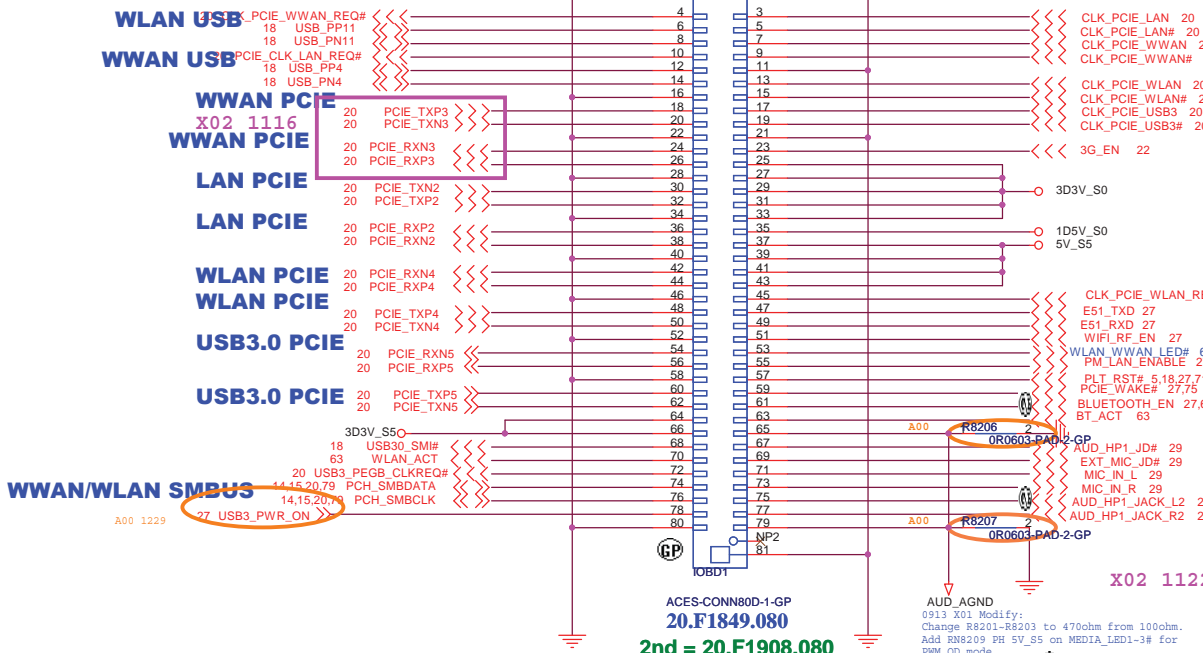

LAN CLK
CLK_PCIE_LAN# 20
CLK_PCIE_LAN# 20
CLK_PCIE_WWAN# 20
CLK_PCIE_WWAN# 20

WWAN CLK
CLK_PCIE_WLAN 20
CLK_PCIE_WLAN# 20
CLK_PCIE_USB3 20
CLK_PCIE_USB3# 20

WLAN CLK
CLK_PCIE_WLAN 20
CLK_PCIE_WLAN# 20
CLK_PCIE_USB3 20
CLK_PCIE_USB3# 20

3G_EN 22

0916 X01 Modify:
Keep original X00 IOBD1 pin define.
0917 X01 Modify:
Change IOBD1 part number to 20.F1849.080
base on Double updated latest DAF&ENM.
0920 X01 Modify:
Re-assign IOBD1 pin define due to updated
connector pin define is different as before.
Add R8206, R8207 to isolated AGND and DGND.

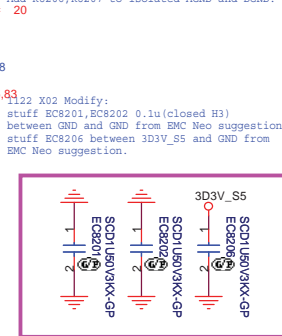

SIGNAL	PIN	PIN	SIGNAL
5V_CRT_S0_R	2	1	CRT_BLUE_R
3D3V_S0	4	3	GND
GND	6	5	CRT_GREEN_R
CRT_HSYNC_CON	8	7	GND
CRT_VSYNC_CON	10	9	CRT_RED_R
GND	12	11	GND
NC	14	13	NC
AD+	16	15	AD+
AD+	18	17	AD+
AD+	20	19	AD+
AD+	22	21	AD+
AD+	24	23	AD+
AD+	26	25	AD+
NC	28	27	NC
PSID_EC	30	29	DDCCLK
RCID	32	31	DDCDATA
GND	34	33	5V_S5
USB_PN1	36	35	3D3V_S5
USB_PP1	38	37	5V_USB1_S3
GND	40	39	5V_USB1_S3

CRT Board Connector

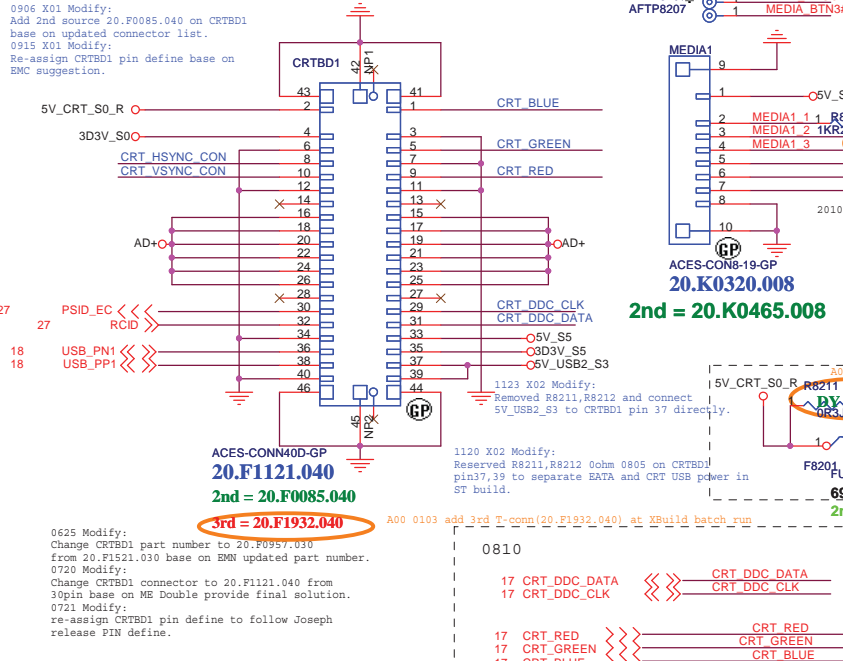

Media LED
MEDIA LED1# 1
MEDIA LED2# R8204
MEDIA LED3# R8205
R8208
10KR2J-3-GP
10KR2J-3-GP

1119 X02 Modify:
Reserved EC8203-EC8205 470p on all of
MEDIA_LED# signal from BMC Neo suggestion.

High active
MEDIA_LED1# 27
MEDIA_LED2# 27
MEDIA_LED3# 27
INSTANT_ON# 27
DATA_RECOVERY# 27
MEDIA_BTN# 27

1110 X02 Modify:
Add 2nd 20.R0465.008 on MEDIA1 from
ME updated connector list.
1112 X02 Modify:
change Media resistor from 430 ohm to 1K on
both DQ/DN15 (R8201, R8202, R8203)
for Media button LED light spot issue

20101220 R8202 R8203 for change to parallel resistor

1120 X02 Modify:
Reserved R8211, R8212 50hm 0805 on CRTBD1
pin37, 39 to separate EATPA and CRT USB power in
ST build.

1123 X02 Modify:
Removed R8211, R8212 and connect
5V_USB2_S3 to CRTBD1 pin 37 directly.

1120 X02 Modify:
Swap R8205 pin4, 3 and pin2, 1 each other
base on Connie swap report.

1120 X02 Modify:
Add R8205
base on HSYNC&VSYNC report.

SIGNAL	PIN	PIN	SIGNAL
GND	80	79	GND
CLK_PCIE_WWAN_REQ#	78	77	CLK_PCIE_LAN
USB_PP11	76	75	CLK_PCIE_LAN#
USB_PN11	74	73	CLK_PCIE_WWAN
PCIE_CLK_LAN_REQ#	72	71	CLK_PCIE_WWAN#
USB_PP4	70	69	GND
USB_PN4	68	67	CLK_PCIE_WLAN
GND	66	65	CLK_PCIE_WLAN#
PCIE_TXP1	64	63	CLK_PCIE_USB3
PCIE_TXN1	62	61	CLK_PCIE_USB3#
GND	60	59	GND
PCIE_RXN1	58	57	3G_EN
PCIE_RXP1	56	55	3D3V_S0
GND	54	53	3D3V_S0
PCIE_TXN2	52	51	3D3V_S0
PCIE_TXP2	50	49	3D3V_S0
GND	48	47	3D3V_S0
PCIE_RXN2	46	45	1D5V_S5
GND	42	41	5V_S5
PCIE_RXN4	40	39	5V_S5
PCIE_RXP4	38	37	5V_S5
GND	36	35	CLK_PCIE_WLAN_REQ#
PCIE_TXP4	34	33	E51_TXD
PCIE_TXN4	32	31	E51_RXD
GND	30	29	WIFI_RF_EN
IOBD1_28	28	27	WLAN_WWAN_LED#
IOBD1_26	26	25	PM_LAN_ENABLE
GND	24	23	PLT_RST#
IOBD1_22	22	21	PCIE_WAKE#
IOBD1_20	20	19	BLUETOOTH_EN
3D3V_S5	18	17	BT_ACT
3D3V_S5	16	15	GND
IOBD1_14	14	13	AUD_HP1_JD#
WLAN_ACT	12	11	EXT_MIC_JD#
USB3_PEGB_CLKREQ#	10	9	MIC_IN_L
PCH_SMBDATA	8	7	MIC_IN_R
PCH_SMBCLK	6	5	AUD_HP1_JACK_L2
USB3_PWR_ON	4	3	AUD_HP1_JACK_R2
GND	2	1	GND

<Core Design>

Wistron Corporation
21F, 88, Sec.1, Hsin Tai Wu Rd., Hsichih,
Taipei Hsien 221, Taiwan, R.O.C.

File
IO Board Connector

Size A3 Document Number **QUEEN 15** Rev **A00**

Date: Tuesday, January 04, 2011 Sheet 82 of 108

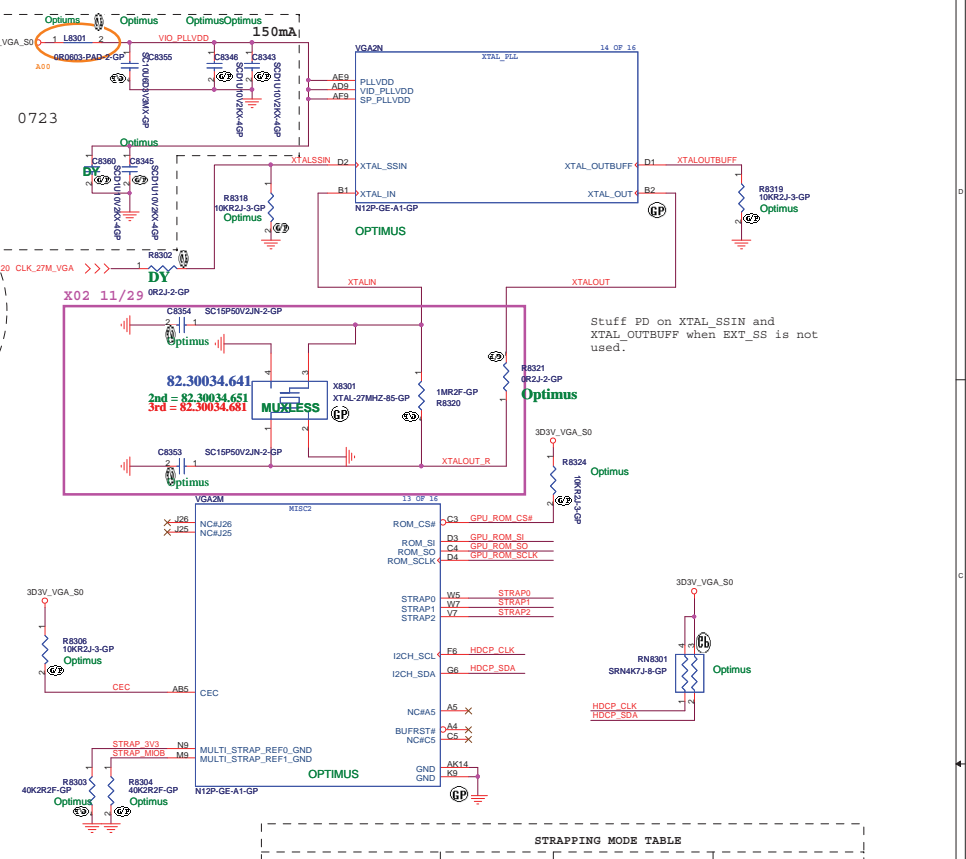
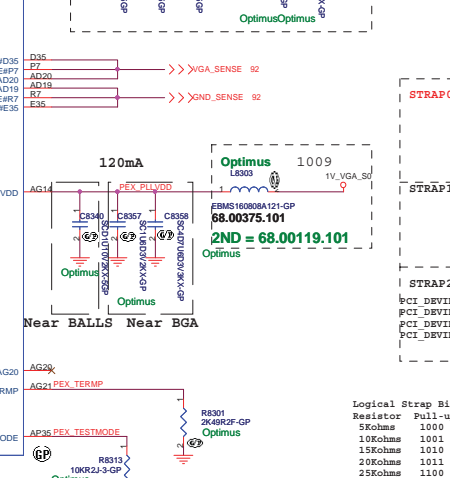
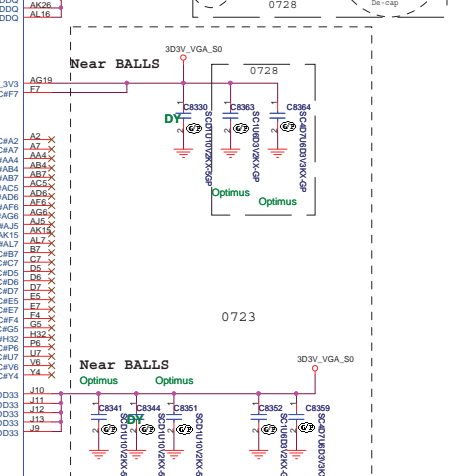
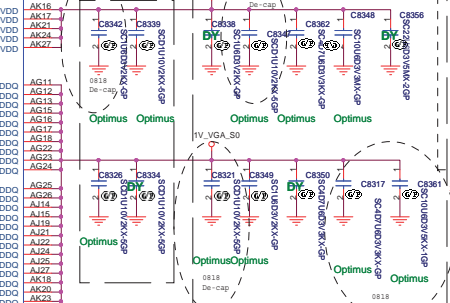
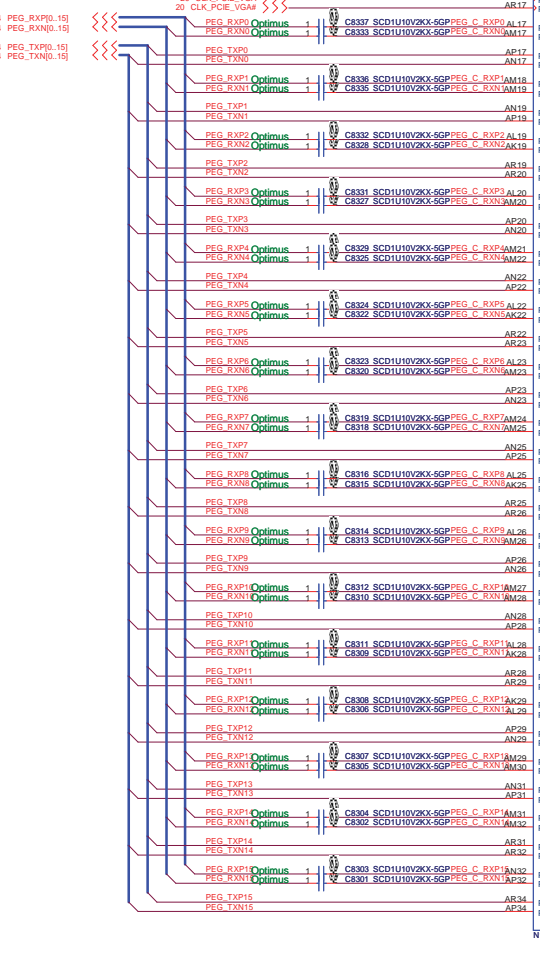
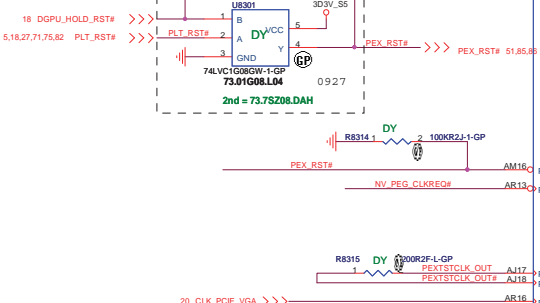
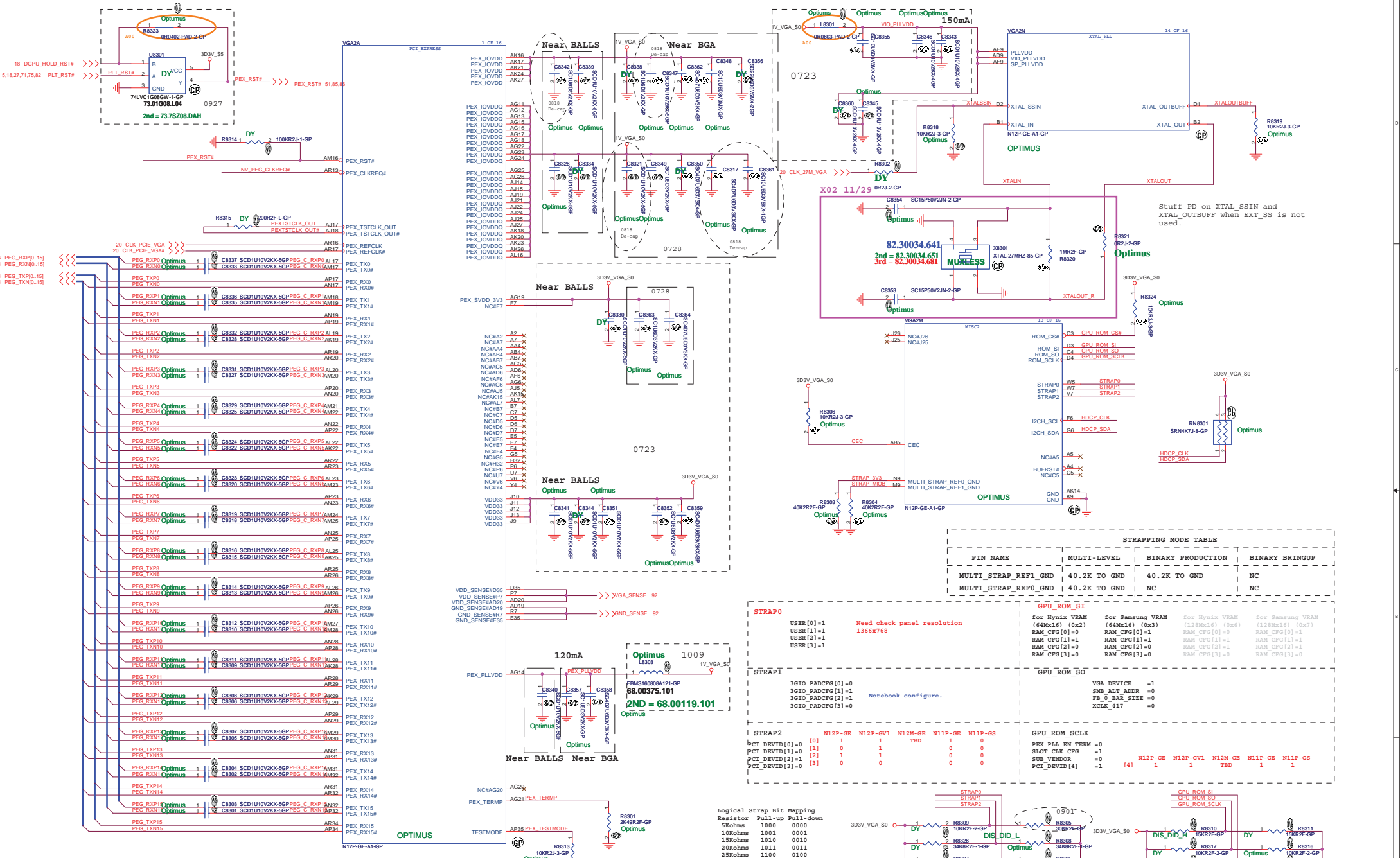

STRAPPING MODE TABLE

PIN NAME	MULTI-LEVEL	BINARY PRODUCTION	BINARY BRINGUP
MULTI_STRAP_REF1_GND	40.2K TO GND	40.2K TO GND	NC
MULTI_STRAP_REF0_GND	40.2K TO GND	NC	NC

GPU_ROM_SI

USER[0]=1	Need check panel resolution 1366x768	for Hynix VRAM (64Mx16) (0x2)	for Samsung VRAM (64Mx16) (0x3)	for Hynix VRAM (128Mx16) (0x6)	for Samsung VRAM (128Mx16) (0x7)
USER[1]=1		RAM_CFG[0]=1	RAM_CFG[0]=1	RAM_CFG[0]=1	RAM_CFG[0]=1
USER[2]=1		RAM_CFG[1]=1	RAM_CFG[1]=1	RAM_CFG[1]=1	RAM_CFG[1]=1
USER[3]=1		RAM_CFG[2]=0	RAM_CFG[2]=0	RAM_CFG[2]=1	RAM_CFG[2]=1
		RAM_CFG[3]=0	RAM_CFG[3]=0	RAM_CFG[3]=0	RAM_CFG[3]=0

GPU_ROM_SO

3GIO_PADCFG[0]=0	3GIO_PADCFG[1]=1	3GIO_PADCFG[2]=1	3GIO_PADCFG[3]=0	VGA_DEVICE =1	SMB_ALI_ADDR =0	FB_0_BAR_SIZE =0	XC1K_417 =0

GPU_ROM_SCLK

bci_devid[0]=0	pci_devid[1]=0	pci_devid[2]=1	pci_devid[3]=0	N12P-GE	N12P-GV1	N12M-GE	N11P-GE	N11P-GS	GPU_ROM_SCLK
0	1	1	TBD	1	0	0	0	0	PEX_PLL_EM_TERM =0
1	0	1	0	0	0	0	0	0	SLOT_CLR_CFG =1
2	1	1	1	0	0	0	0	0	SUB_VENDOR =0
3	0	0	0	0	0	0	0	0	PCI_DEVID[4] =-1

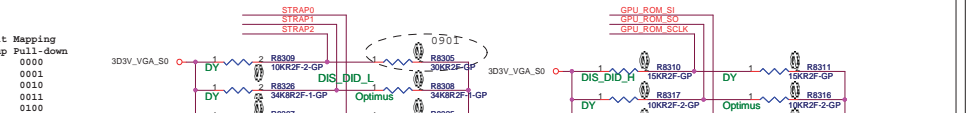

Logical Strap Bit Mapping

Resistor	Full-up	Pull-down
50kOhm	1001	0010
10kOhm	1010	0011
15kOhm	1011	0100
20kOhm	1011	0101
25kOhm	1100	0100
30kOhm	1101	0101
35kOhm	1110	0110
45kOhm	1111	0111

Strap 2: DIS_DID_L

0xDP5	N12P-GE	PH = NC, PL = 30K(64.30025.6DL)
	N12P-GV1	PH = NC, PL = 15K(64.15025.6DL)
	N12M-GE	PH = TBD, PL = TBD
	N11P-GE-A1	PH = TBD, PL = 10K
	N11P-GS-A1	PH = NC, PL = 4.99K

GPU_ROM_SCLK: DIS_DID_H

N12P-GE	PH = 15K(64.15025.6DL), PL = NC
N12P-GV1	PH = 15K(64.15025.6DL), PL = NC
N12M-GE	PH = TBD, PL = TBD
N11P-GS-A1	PH = 15K(64.15025.6DL), PL = NC
N11P-GS-A1	PH = 15K(64.15025.6DL), PL = NC

GPU_ROM_SI

Hynix	64x16 = PL 15K
Samsung	64x16 = PL 20K

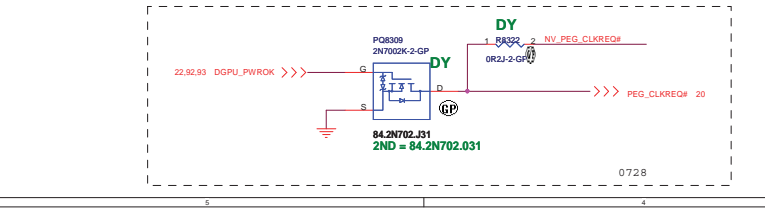

Wistron Corporation
 21F, 88, Sec.1, Hsin Tai Wu Rd., Hsiehshui, Taipei Hsien 221, Taiwan, R.O.C.

File: **N12P(1/6) PEG**

Size: **QUEEN 15**

Rev: **A00**

Date: Tuesday, January 04, 2011 Sheet: 83 of 108

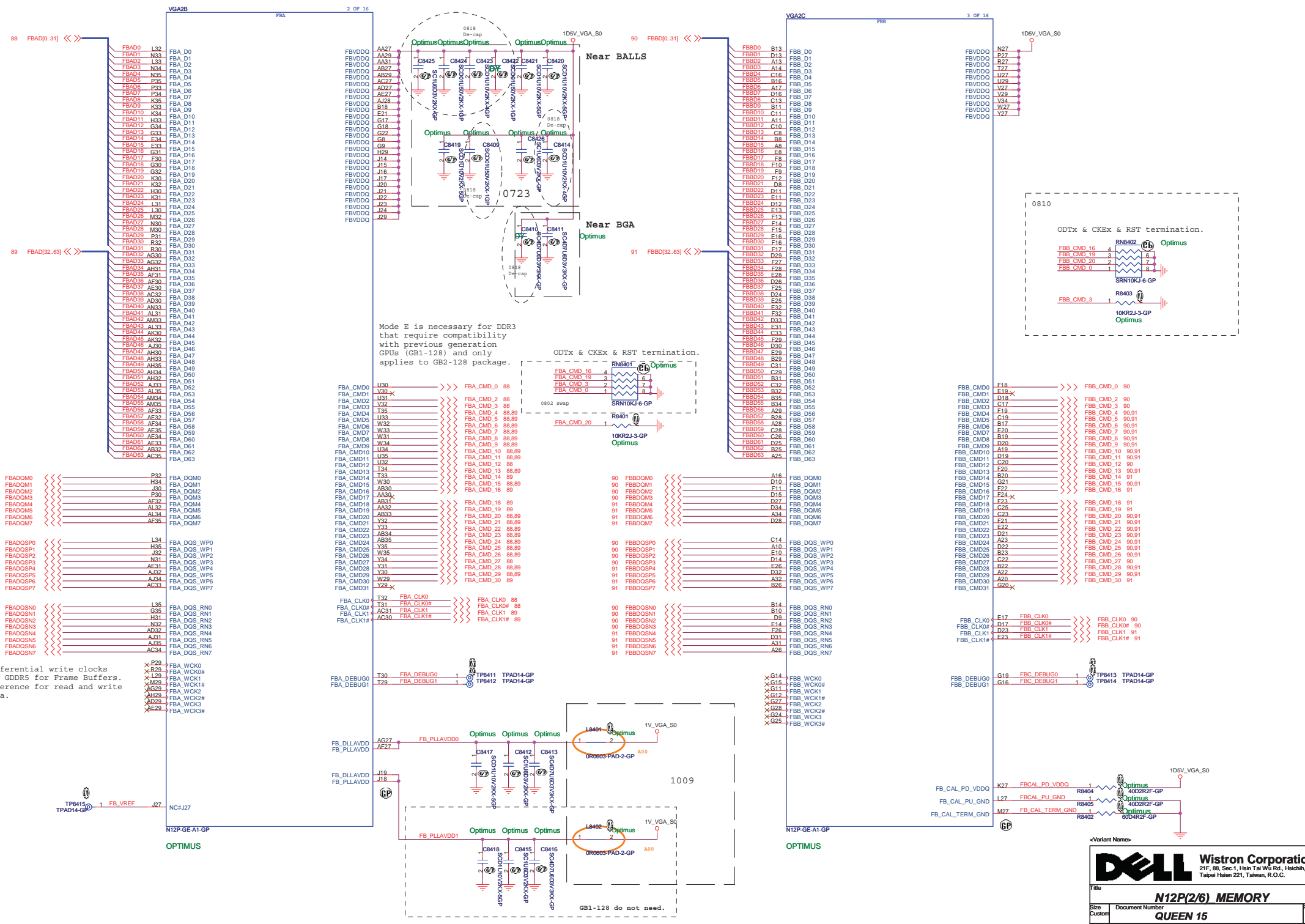

Mode E is necessary for DDR3 that require compatibility with previous generation GPUs (GB1-128) and only applies to GB2-128 package.

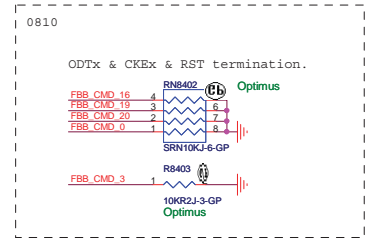
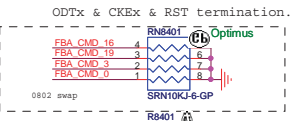

88	FBAD[0..31]	<<<	FBAD0 L32	FBA D0
			FBAD1 N33	FBA D1
			FBAD2 L34	FBA D2
			FBAD3 N34	FBA D3
			FBAD4 L35	FBA D4
			FBAD5 N35	FBA D5
			FBAD6 P33	FBA D6
			FBAD7 P34	FBA D7
			FBAD8 K35	FBA D8
			FBAD9 K33	FBA D9
			FBAD10 H34	FBA D10
			FBAD11 H33	FBA D11
			FBAD12 G34	FBA D12
			FBAD13 G33	FBA D13
			FBAD14 E34	FBA D14
			FBAD15 E33	FBA D15
			FBAD16 G31	FBA D16
			FBAD17 F30	FBA D17
			FBAD18 G30	FBA D18
			FBAD19 G32	FBA D19
			FBAD20 K30	FBA D20
			FBAD21 K32	FBA D21
			FBAD22 H30	FBA D22
			FBAD23 K31	FBA D23
			FBAD24 L31	FBA D24
			FBAD25 L30	FBA D25
			FBAD26 N32	FBA D26
			FBAD27 N30	FBA D27
			FBAD28 N30	FBA D28
			FBAD29 P31	FBA D29
			FBAD30 R32	FBA D30
			FBAD31 R30	FBA D31
			FBAD32 AG30	FBA D32
			FBAD33 AG32	FBA D33
			FBAD34 AH31	FBA D34
			FBAD35 AF31	FBA D35
			FBAD36 AF30	FBA D36
			FBAD37 AF30	FBA D37
			FBAD38 AC32	FBA D38
			FBAD39 AD30	FBA D39
			FBAD40 AN33	FBA D40
			FBAD41 AL31	FBA D41
			FBAD42 AM33	FBA D42
			FBAD43 AL33	FBA D43
			FBAD44 AK30	FBA D44
			FBAD45 AK32	FBA D45
			FBAD46 AU30	FBA D46
			FBAD47 AH30	FBA D47
			FBAD48 AH33	FBA D48
			FBAD49 AH35	FBA D49
			FBAD50 AH34	FBA D50
			FBAD51 AH32	FBA D51
			FBAD52 AU33	FBA D52
			FBAD53 AL36	FBA D53
			FBAD54 AM34	FBA D54
			FBAD55 AM35	FBA D55
			FBAD56 AF33	FBA D56
			FBAD57 AE32	FBA D57
			FBAD58 AF34	FBA D58
			FBAD59 AE35	FBA D59
			FBAD60 AE34	FBA D60
			FBAD61 AC33	FBA D61
			FBAD62 AB32	FBA D62
			FBAD63 AC36	FBA D63

Differential write clocks for GDDR5 for Frame Buffers. Reference for read and write data.

FBA_CMD0	U30	>>>	FBA_CMD_0 88
FBA_CMD1	U30-X	>>>	
FBA_CMD2	U31	>>>	FBA_CMD 2 88
FBA_CMD3	U32	>>>	FBA_CMD 3 88
FBA_CMD4	T35	>>>	FBA_CMD 4 88,89
FBA_CMD5	U33	>>>	FBA_CMD 5 88,89
FBA_CMD6	W32	>>>	FBA_CMD 6 88,89
FBA_CMD7	U34	>>>	FBA_CMD 7 88,89
FBA_CMD8	W34	>>>	FBA_CMD 8 88,89
FBA_CMD9	U34	>>>	FBA_CMD 9 88,89
FBA_CMD10	U32	>>>	FBA_CMD 10 88,89
FBA_CMD11	U35	>>>	FBA_CMD 11 88,89
FBA_CMD12	T34	>>>	FBA_CMD 12 88,89
FBA_CMD13	W30	>>>	FBA_CMD 13 88,89
FBA_CMD14	T33	>>>	FBA_CMD 14 89
FBA_CMD15	AB30	>>>	FBA_CMD 15 88,89
FBA_CMD16	AA30	>>>	FBA_CMD 16 89
FBA_CMD17	AA30	>>>	FBA_CMD 17 89
FBA_CMD18	AB31	>>>	FBA_CMD 18 89
FBA_CMD19	AA31	>>>	FBA_CMD 19 89
FBA_CMD20	AB33	>>>	FBA_CMD 20 88,89
FBA_CMD21	Y32	>>>	FBA_CMD 21 88,89
FBA_CMD22	Y33	>>>	FBA_CMD 22 88,89
FBA_CMD23	AB34	>>>	FBA_CMD 23 88,89
FBA_CMD24	AB35	>>>	FBA_CMD 24 88,89
FBA_CMD25	Y35	>>>	FBA_CMD 25 88,89
FBA_CMD26	W35	>>>	FBA_CMD 26 88,89
FBA_CMD27	X31	>>>	FBA_CMD 27 88
FBA_CMD28	X31	>>>	FBA_CMD 28 88,89
FBA_CMD29	Y30	>>>	FBA_CMD 29 88,89
FBA_CMD30	W29	>>>	FBA_CMD 30 89
FBA_CMD31	Y29-X	>>>	

FBA_CLK0	T32	FBA_CLK0	>>>	FBA_CLK0 88
FBA_CLK0#	T31	FBA_CLK0#	>>>	FBA_CLK0# 88
FBA_CLK1	AC31	FBA_CLK1	>>>	FBA_CLK1 89
FBA_CLK1#	AC30	FBA_CLK1#	>>>	FBA_CLK1# 89

FBA_DEBUG0	T30	FBA_DEBUG0	>>>	TP8411	TPAD14-GP
FBA_DEBUG1	T29	FBA_DEBUG1	>>>	TP8412	TPAD14-GP

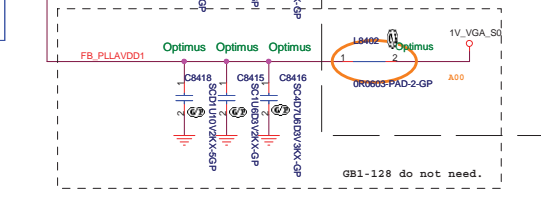
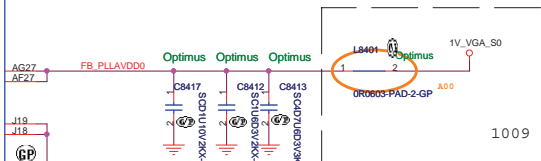

90	FBBD[0..31]	<<<	FBBD0 B13	FBB D0
			FBBD1 D13	FBB D1
			FBBD2 D13	FBB D2
			FBBD3 A14	FBB D3
			FBBD4 C16	FBB D4
			FBBD5 B16	FBB D5
			FBBD6 A17	FBB D6
			FBBD7 C16	FBB D7
			FBBD8 B11	FBB D8
			FBBD9 B11	FBB D9
			FBBD10 C11	FBB D10
			FBBD11 A11	FBB D11
			FBBD12 C10	FBB D12
			FBBD13 B8	FBB D13
			FBBD14 B8	FBB D14
			FBBD15 A8	FBB D15
			FBBD16 E8	FBB D16
			FBBD17 F8	FBB D17
			FBBD18 F10	FBB D18
			FBBD19 F9	FBB D19
			FBBD20 F12	FBB D20
			FBBD21 D8	FBB D21
			FBBD22 D11	FBB D22
			FBBD23 E11	FBB D23
			FBBD24 D12	FBB D24
			FBBD25 E12	FBB D25
			FBBD26 F13	FBB D26
			FBBD27 E14	FBB D27
			FBBD28 E16	FBB D28
			FBBD29 E16	FBB D29
			FBBD30 F16	FBB D30
			FBBD31 F16	FBB D31
			FBBD32 D29	FBB D32
			FBBD33 F27	FBB D33
			FBBD34 E28	FBB D34
			FBBD35 E28	FBB D35
			FBBD36 D26	FBB D36
			FBBD37 F28	FBB D37
			FBBD38 D24	FBB D38
			FBBD39 E25	FBB D39
			FBBD40 E24	FBB D40
			FBBD41 F32	FBB D41
			FBBD42 D33	FBB D42
			FBBD43 E31	FBB D43
			FBBD44 C33	FBB D44
			FBBD45 F29	FBB D45
			FBBD46 D38	FBB D46
			FBBD47 E29	FBB D47
			FBBD48 B29	FBB D48
			FBBD49 C31	FBB D49
			FBBD50 C29	FBB D50
			FBBD51 B31	FBB D51
			FBBD52 B32	FBB D52
			FBBD53 B31	FBB D53
			FBBD54 B35	FBB D54
			FBBD55 B34	FBB D55
			FBBD56 A29	FBB D56
			FBBD57 B28	FBB D57
			FBBD58 A28	FBB D58
			FBBD59 C28	FBB D59
			FBBD60 C26	FBB D60
			FBBD61 D25	FBB D61
			FBBD62 B25	FBB D62
			FBBD63 A25	FBB D63

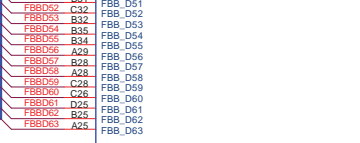

91	FBBD[32..63]	<<<	FBBD32 D29	FBB D32
			FBBD33 F27	FBB D33
			FBBD34 E28	FBB D34
			FBBD35 E28	FBB D35
			FBBD36 D26	FBB D36
			FBBD37 F28	FBB D37
			FBBD38 D24	FBB D38
			FBBD39 E25	FBB D39
			FBBD40 E24	FBB D40
			FBBD41 F32	FBB D41
			FBBD42 D33	FBB D42
			FBBD43 E31	FBB D43
			FBBD44 C33	FBB D44
			FBBD45 F29	FBB D45
			FBBD46 D38	FBB D46
			FBBD47 E29	FBB D47
			FBBD48 B29	FBB D48
			FBBD49 C31	FBB D49
			FBBD50 C29	FBB D50
			FBBD51 B31	FBB D51
			FBBD52 B32	FBB D52
			FBBD53 B31	FBB D53
			FBBD54 B35	FBB D54
			FBBD55 B34	FBB D55
			FBBD56 A29	FBB D56
			FBBD57 B28	FBB D57
			FBBD58 A28	FBB D58
			FBBD59 C28	FBB D59
			FBBD60 C26	FBB D60
			FBBD61 D25	FBB D61
			FBBD62 B25	FBB D62
			FBBD63 A25	FBB D63

90	FBBDQM0	<<<	A16	FBB_DQM0
	FBBDQM1	<<<	D10	FBB_DQM1
	FBBDQM2	<<<	F11	FBB_DQM2
	FBBDQM3	<<<	D15	FBB_DQM3
	FBBDQM4	<<<	D27	FBB_DQM4
	FBBDQM5	<<<	D34	FBB_DQM5
	FBBDQM6	<<<	A34	FBB_DQM6
	FBBDQM7	<<<	D28	FBB_DQM7

90	FBBDQSP0	<<<	C10	FBB_DQS_WP0
	FBBDQSP1	<<<	A14	FBB_DQS_WP1
	FBBDQSP2	<<<	E10	FBB_DQS_WP2
	FBBDQSP3	<<<	D14	FBB_DQS_WP3
	FBBDQSP4	<<<	E26	FBB_DQS_WP4
	FBBDQSP5	<<<	D32	FBB_DQS_WP5
	FBBDQSP6	<<<	A32	FBB_DQS_WP6
	FBBDQSP7	<<<	B26	FBB_DQS_WP7

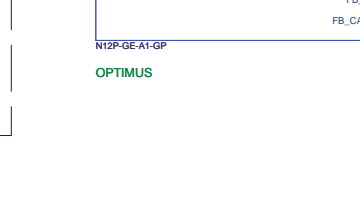

FBB_CMD0	F18	>>>	FBB_CMD_0 90
FBB_CMD1	E19-X	>>>	
FBB_CMD2	D18	>>>	FBB_CMD 2 90
FBB_CMD3	C17	>>>	FBB_CMD 3 90
FBB_CMD4	F19	>>>	FBB_CMD 4 90,91
FBB_CMD5	C19	>>>	FBB_CMD 5 90,91
FBB_CMD6	B17	>>>	FBB_CMD 6 90,91
FBB_CMD7	E19	>>>	FBB_CMD 7 90,91
FBB_CMD8	B19	>>>	FBB_CMD 8 90,91
FBB_CMD9	A19	>>>	FBB_CMD 9 90,91
FBB_CMD10	D20	>>>	FBB_CMD 10 90,91
FBB_CMD11	F20	>>>	FBB_CMD 11 90,91
FBB_CMD12	E20	>>>	FBB_CMD 12 90
FBB_CMD13	G21	>>>	FBB_CMD 13 90,91
FBB_CMD14	B20	>>>	FBB_CMD 14 91
FBB_CMD15	F22	>>>	FBB_CMD 15 90,91
FBB_CMD16	G21	>>>	FBB_CMD 16 91
FBB_CMD17	F24-X	>>>	
FBB_CMD18	F23	>>>	FBB_CMD 18 91
FBB_CMD19	C25	>>>	FBB_CMD 19 91
FBB_CMD20	F21	>>>	FBB_CMD 20 90,91
FBB_CMD21	E22	>>>	FBB_CMD 21 90,91
FBB_CMD22	E22	>>>	FBB_CMD 22 90,91
FBB_CMD23	D21	>>>	FBB_CMD 23 90,91
FBB_CMD24	A23	>>>	FBB_CMD 24 90,91
FBB_CMD25	D22	>>>	FBB_CMD 25 90,91
FBB_CMD26	B23	>>>	FBB_CMD 26 90,91
FBB_CMD27	C22	>>>	FBB_CMD 27 90
FBB_CMD28	B22	>>>	FBB_CMD 28 90,91
FBB_CMD29	A22	>>>	FBB_CMD 29 90,91
FBB_CMD30	A20	>>>	FBB_CMD 30 91
FBB_CMD31	G20-X	>>>	

FBB_CLK0	E17	FBB_CLK0	>>>	FBB_CLK0 90
FBB_CLK0#	D17	FBB_CLK0#	>>>	FBB_CLK0# 90
FBB_CLK1	D23	FBB_CLK1	>>>	FBB_CLK1 91
FBB_CLK1#	E23	FBB_CLK1#	>>>	FBB_CLK1# 91

FBB_DEBUG0	G19	FBB_DEBUG0	>>>	TP8413	TPAD14-GP
FBB_DEBUG1	G16	FBB_DEBUG1	>>>	TP8414	TPAD14-GP

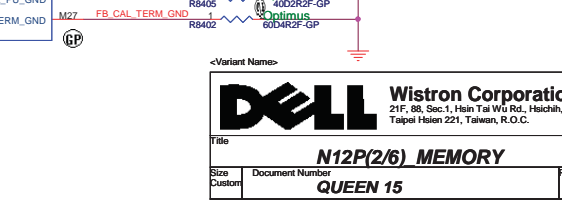
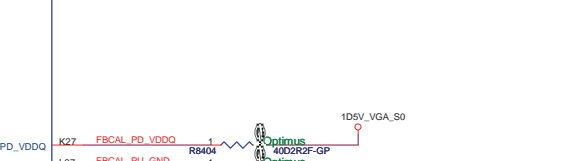

<Variant Name>

Wistron Corporation
21F, 88, Sec.1, Hsin Tai Wo Rd, Hsinsh, Taipei Hsin Tai, Taiwan, R.O.C.

Title: **N12P(2/6) MEMORY**

Size: **QUEEN 15**

Customer: **QUEEN 15**

Rev: **A00**

Date: **Tuesday, January 04, 2011** Sheet **84** of **108**

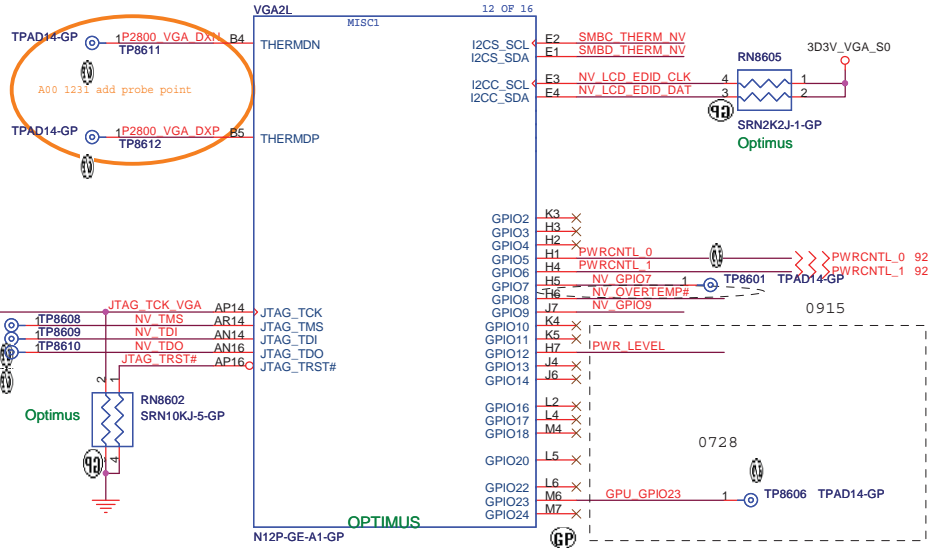
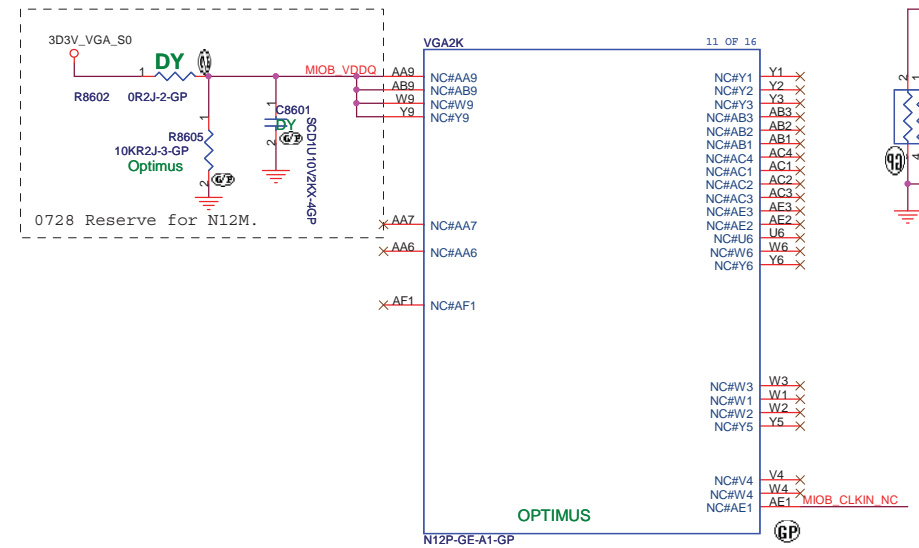
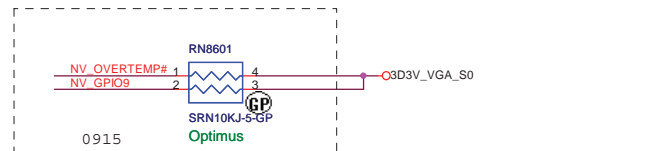
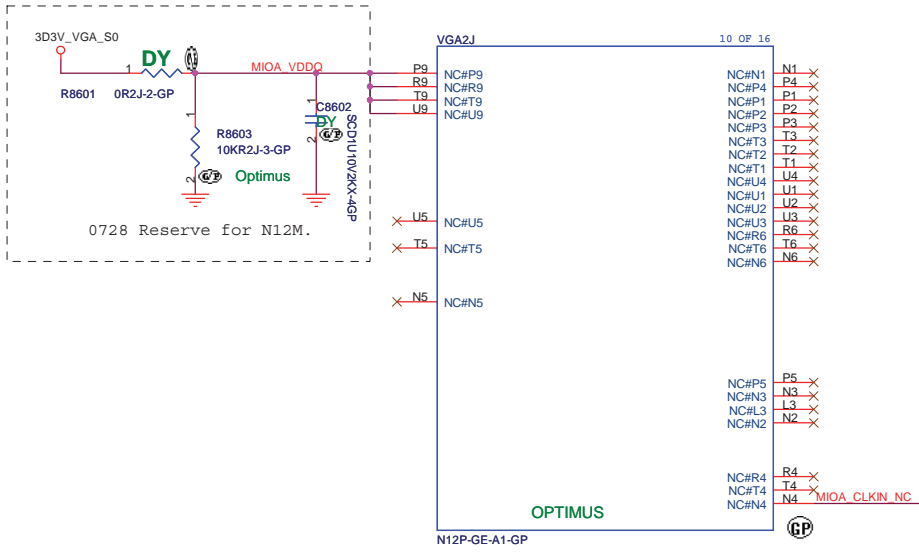

MIOA/B Support

Package	MIOA	MIOB
GB1-192	15-bit, available	TBD
GB2-128	Not available	Not available

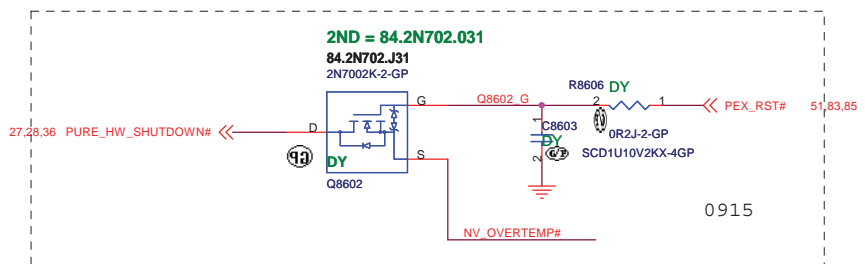

Variant Name:

Wistron Corporation
21F, 88, Sec.1, Hsin Tai Wu Rd., Hsichih, Taipei Hsin 221, Taiwan, R.O.C.

Title: **N12P(5/6) MIO/ GPIO**

Size A3 Document Number **QUEEN 15** Rev **A00**

Date: Tuesday, January 04, 2011 Sheet 86 of 108

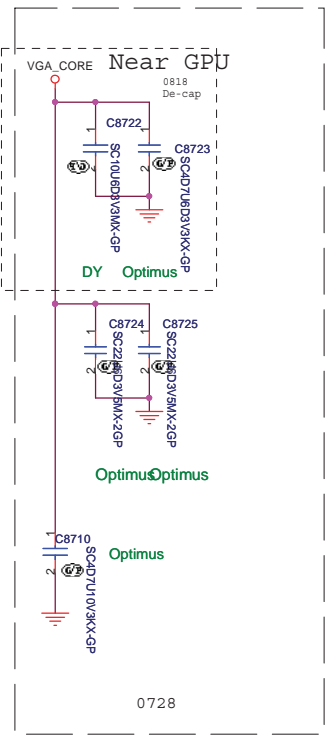
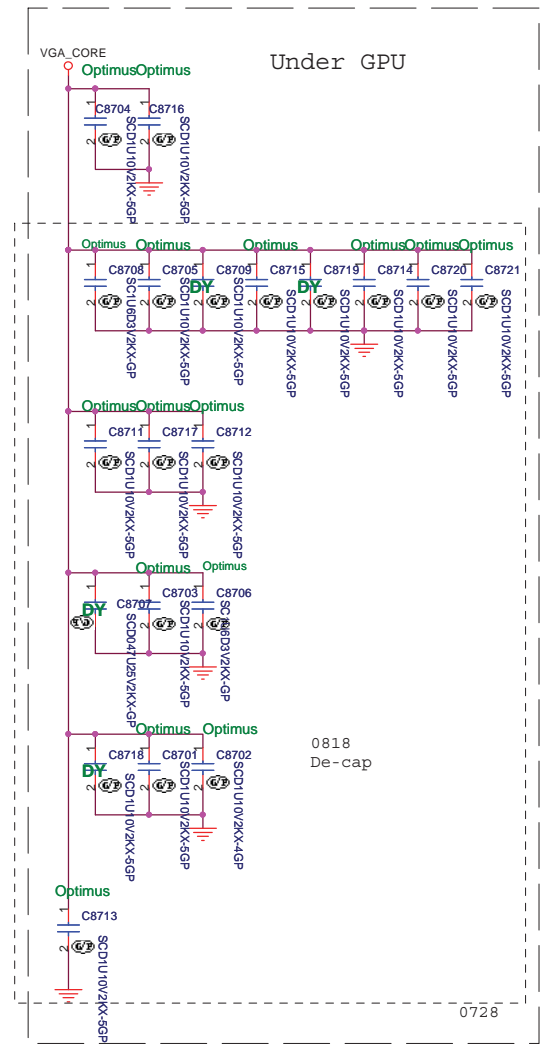
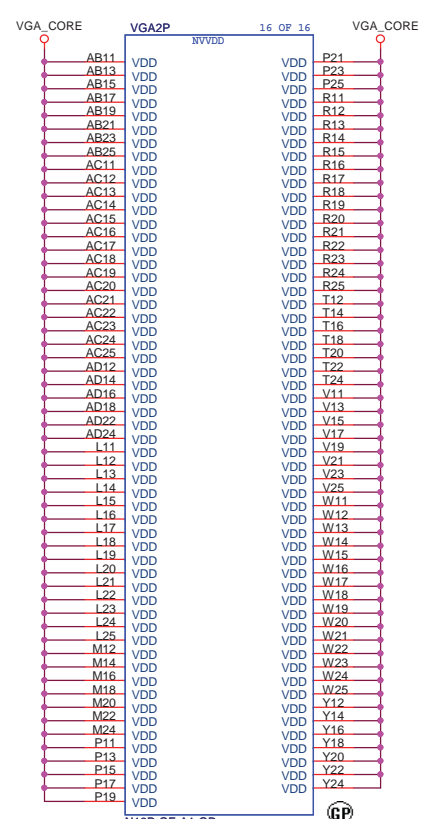
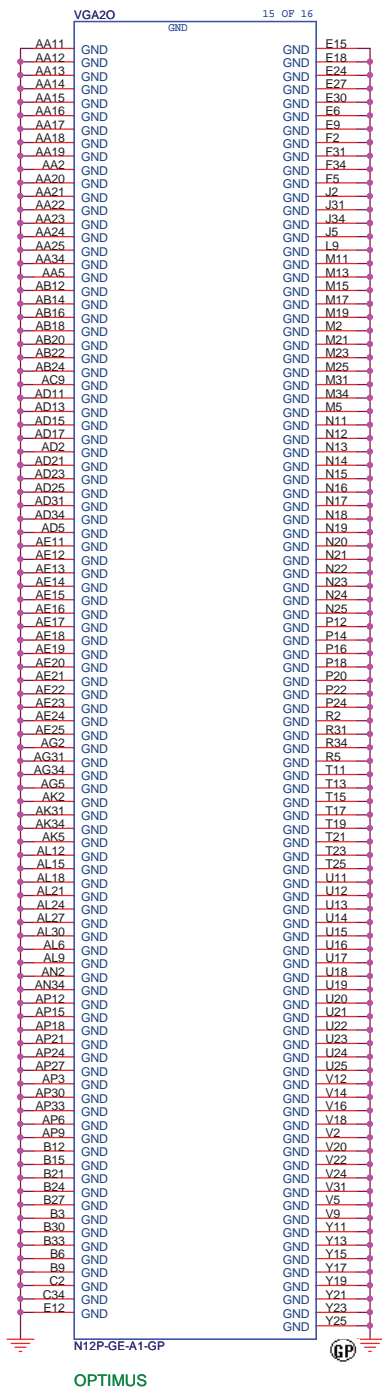

<Variant Name>



Wistron Corporation
21F, 88, Sec.1, Hsin Tai Wu Rd., Hsichih,
Taipei Hsien 221, Taiwan, R.O.C.

Title: **N12P(6/6) POWER**

Size A3 Document Number **QUEEN 15** Rev **A00**

Date: Tuesday, January 04, 2011 Sheet 87 of 108

Frame Buffer Partition A Lower 32 bits.

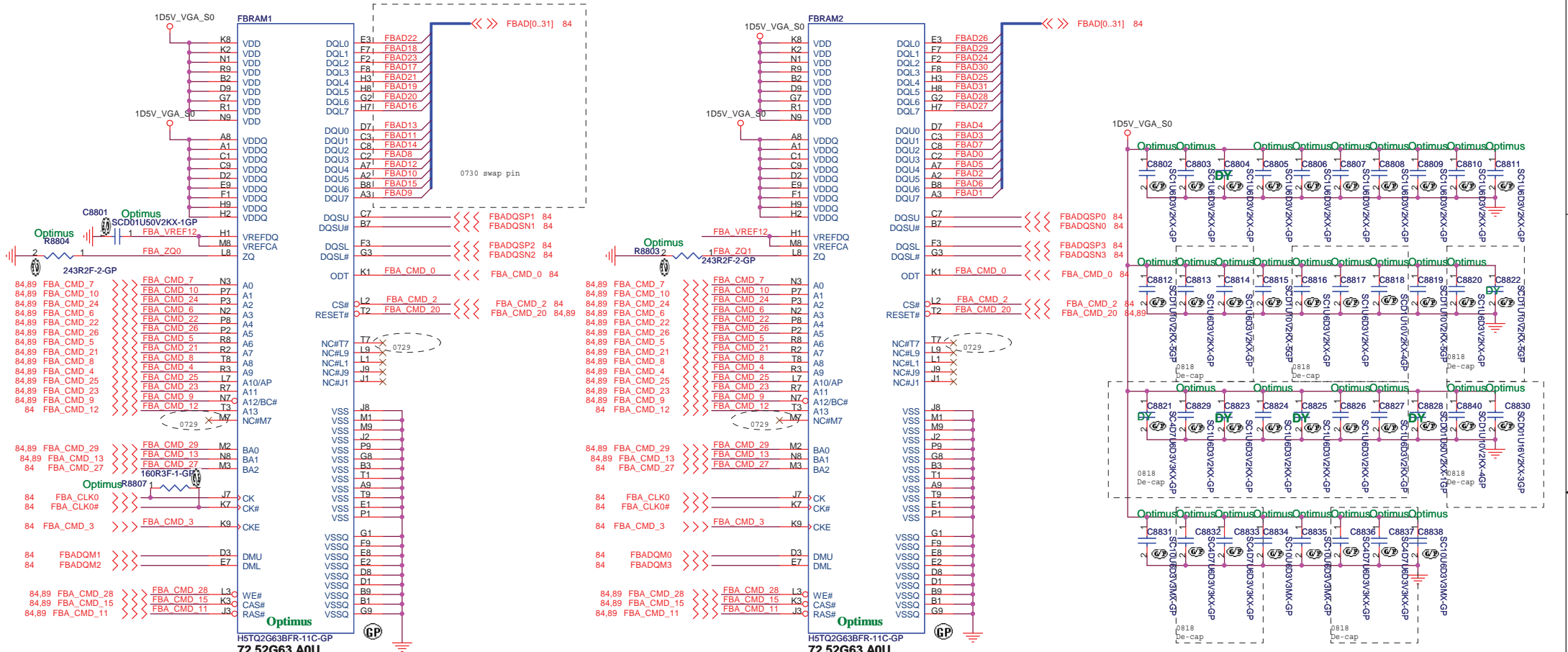

2nd = 72.41164.I0U
PCB Footprint = BGA96D0913H48
 1112 X02 Modify:
 All of VRAM PCB footprint change to CO-LAY type
 (DUMMY-BGA96D075133H48) from BGA96D0913H48

2nd = 72.41164.I0U
PCB Footprint = BGA96D0913H48
 1112 X02 Modify:
 All of VRAM PCB footprint change to CO-LAY type
 (DUMMY-BGA96D075133H48) from BGA96D0913H48

GB1-128 Mode C Single Rank	GB2-128 Mode E	DRAM Function	32..63
CMD25	CMD0	ODT	
CMD23	CMD1	CS1*	
CMD2	CMD2	CS0*	
CMD0	CMD3	CKE	
CMD10	CMD4	A9	A11
CMD6	CMD5	A8	A2
CMD14	CMD6	A3	BA1
CMD7	CMD7	A0	A12
CMD1	CMD8	A8	A8
CMD22	CMD9	A12	A0
CMD20	CMD10	A1	A2
CMD24	CMD11	RA0*	BA0*
CMD18	CMD12	A13	A4
CMD9	CMD13	BA1	A3
CMD26	CMD14	A14	A13
CMD8	CMD15	CAS*	CAS*
CMD27	CMD16	CKE	
CMD5	CMD17	CS1*	
CMD11	CMD18	CS0*	
CMD16	CMD19	ODT	
CMD28	CMD20	RST	
CMD3	CMD21	A7	A6
CMD17	CMD22	A4	A5
CMD5	CMD23	A11	A9
CMD4	CMD24	A2	A1
CMD21	CMD25	A10	WE*
CMD6	CMD26	A5	A4
CMD13	CMD27	BA2	A15
CMD19	CMD28	WE*	A10
CMD12	CMD29	BA0	BA0
CMD20	CMD30	A15	BA2

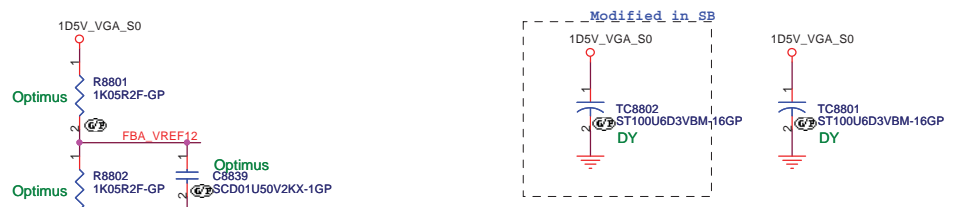

<Variant Name>

Wistron Corporation
 21F, 88, Sec.1, Hsin Tai Wu Rd., Hsichih, Taipei Hsein 221, Taiwan, R.O.C.

Title: **VRAM(1/4)**

Size: A3
 Document Number: **QUEEN 15**
 Date: Tuesday, January 04, 2011
 Sheet: 88 of 108

Rev: **A00**

Frame Buffer Partition A Upper 32 bits.

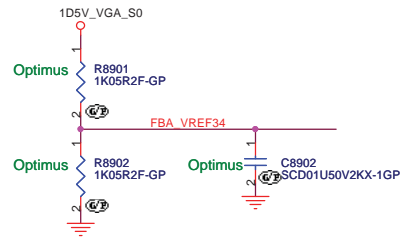
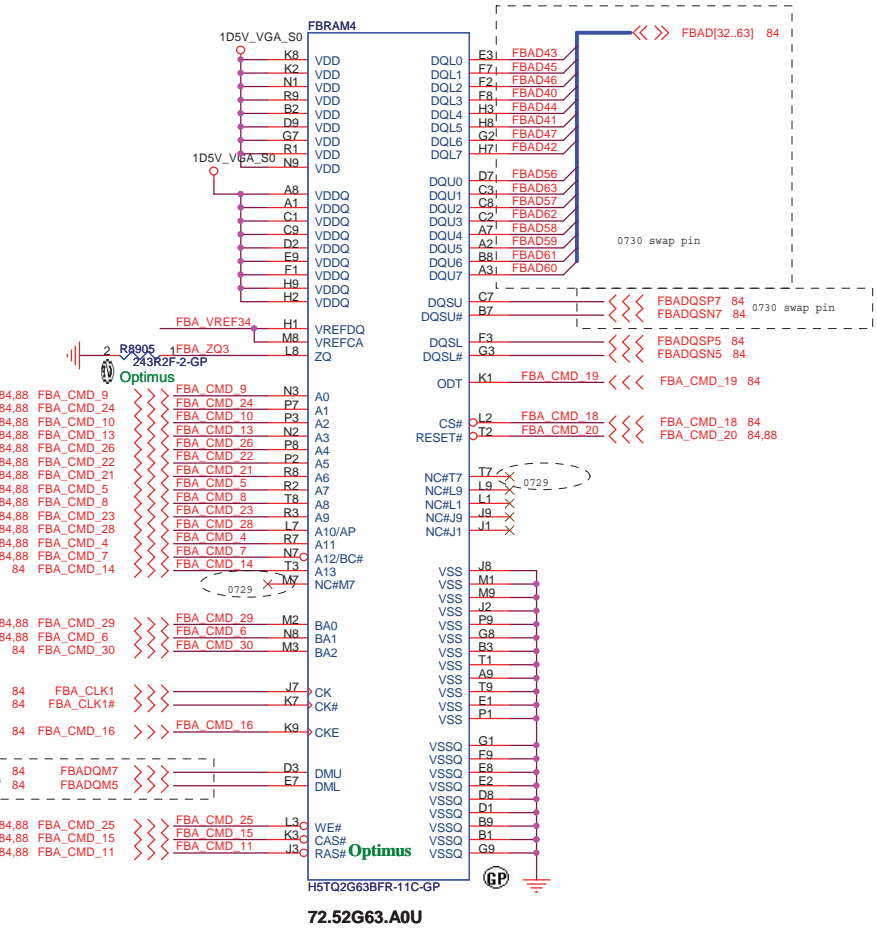
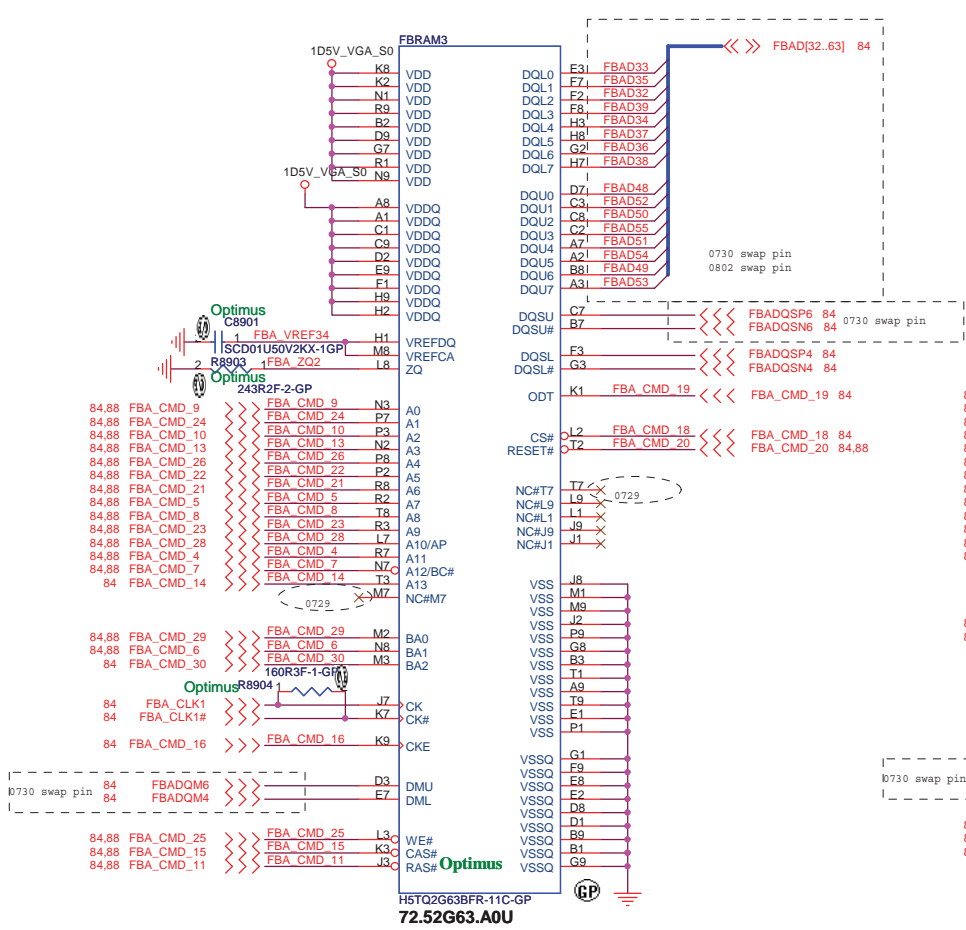

<Variant Name>



Wistron Corporation
 21F, 88, Sec.1, Hsin Tai Wu Rd., Hsichih,
 Taipei Hsien 221, Taiwan, R.O.C.

Title: **VRAM(2/4)**

Size A3 Document Number **QUEEN 15** Rev **A00**

Date: Tuesday, January 04, 2011 Sheet 89 of 108

Frame Buffer Partition B Lower 32 bits.

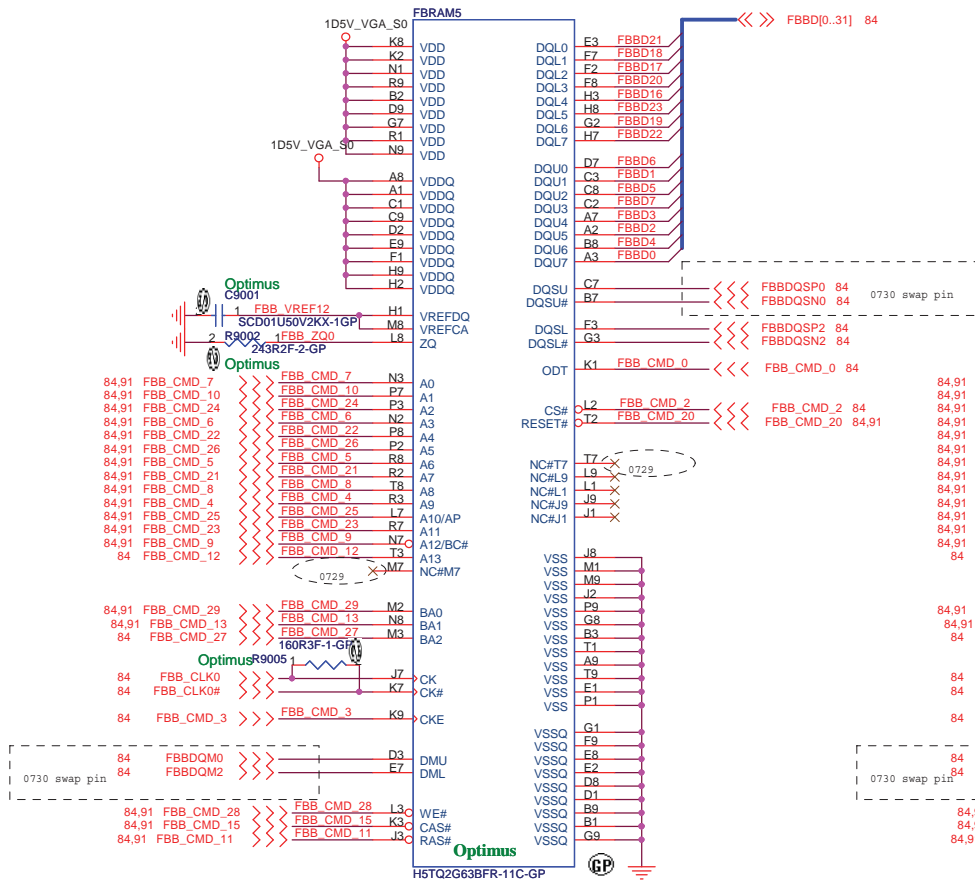

72.52G63.A0U
2nd = 72.41164.I0U
PCB Footprint = BGA96D0913H48

1112 X02 Modify:
 All of VRAM PCB footprint change to CO-LAY type
 (DUMMY-BGA96D075133H48) from BGA96D0913H48

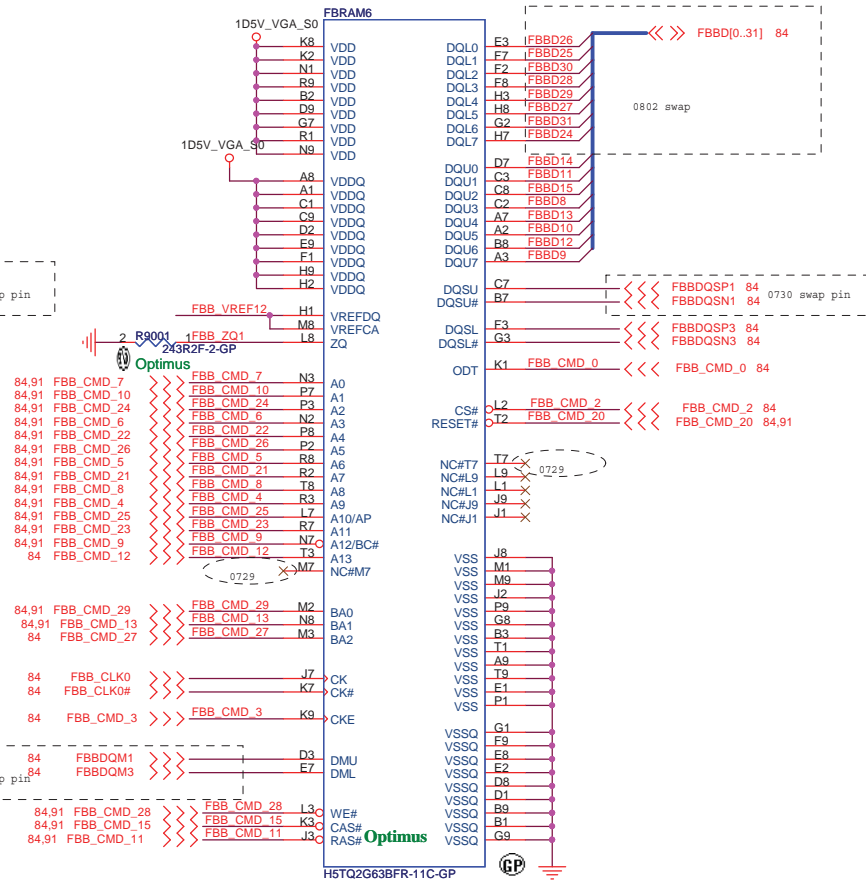

72.52G63.A0U
2nd = 72.41164.I0U
PCB Footprint = BGA96D0913H48

1112 X02 Modify:
 All of VRAM PCB footprint change to CO-LAY type
 (DUMMY-BGA96D075133H48) from BGA96D0913H48

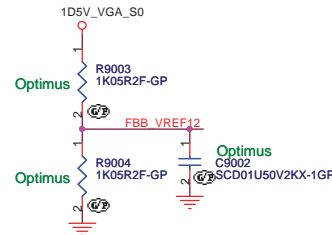

<Variant Name>

Wistron Corporation
 21F, 88, Sec.1, Hsin Tai Wu Rd., Hsichih,
 Taipei Hsein 221, Taiwan, R.O.C.

Title: **VRAM(3/4)**

Size A3 Document Number **QUEEN 15** Rev **A00**

Date: Tuesday, January 04, 2011 Sheet 90 of 108

Frame Buffer Partition B Upper 32 bits.

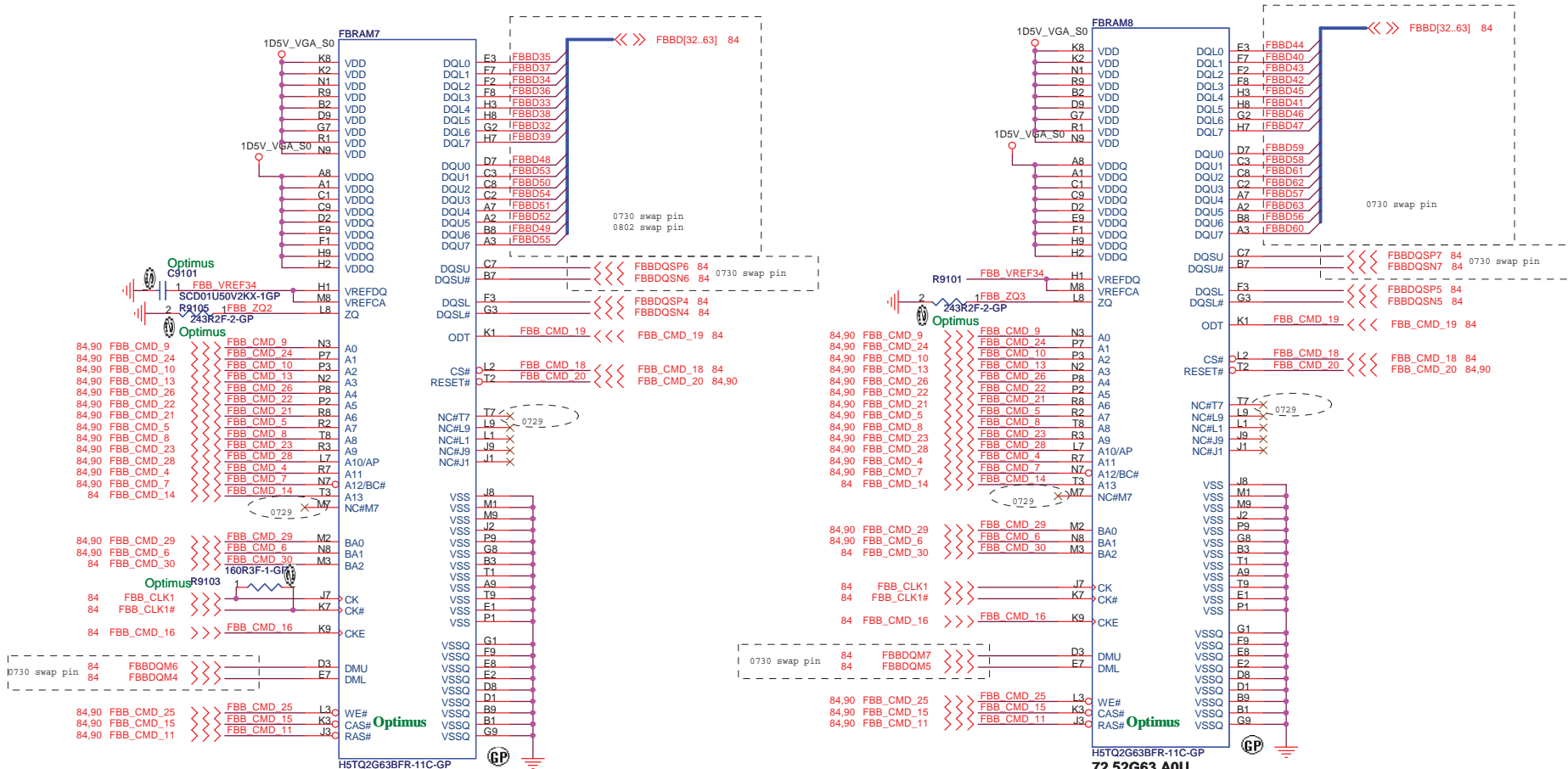

72.52G63.A0U
2nd = 72.41164.I0U
PCB Footprint = BGA96D0913H48

72.52G63.A0U
2nd = 72.41164.I0U
PCB Footprint = BGA96D0913H48

1112 X02 Modify:
 All of VRAM PCB footprint change to CO-LAY type
 (DUMMT-BGA96D075133H48) from BGA96D0913H48

1112 X02 Modify:
 All of VRAM PCB footprint change to CO-LAY type
 (DUMMT-BGA96D075133H48) from BGA96D0913H48

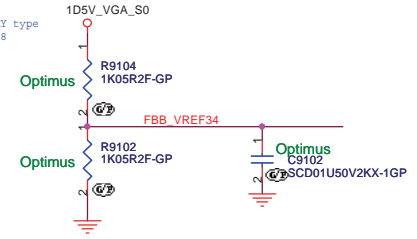

<Variant Name>

		Wistron Corporation 21F, 88, Sec.1, Hsin Tai Wu Rd., Hsichih, Taipei Hsien 221, Taiwan, R.O.C.	
		Title VRAM(4/4)	
Size	Document Number	Rev	
A3	QUEEN 15	A00	
Date:	Tuesday, January 04, 2011	Sheet	91 of 108

SSID = PWR.Plane.Regulator_GFX

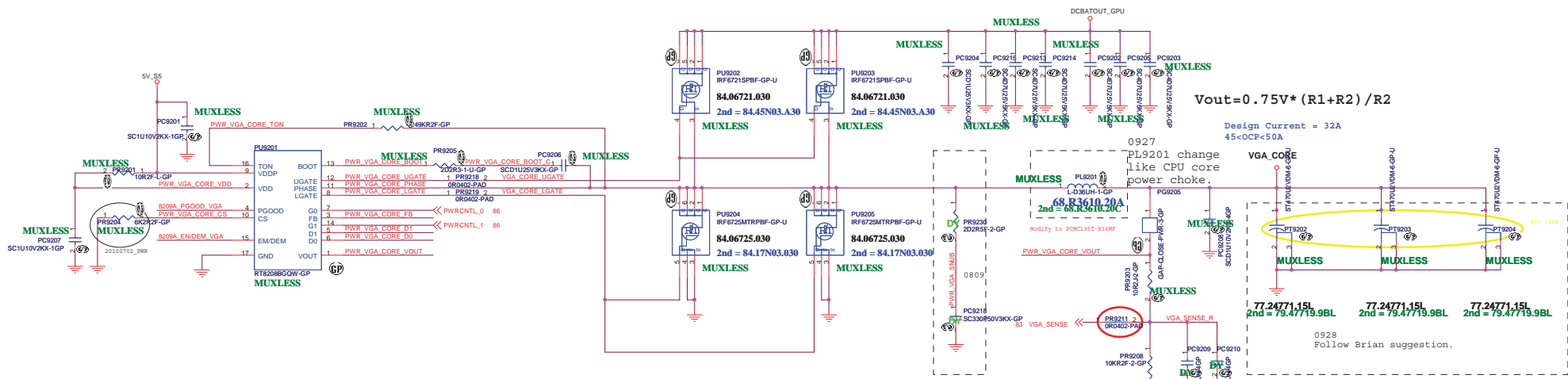

$V_{out} = 0.75V * (R1 + R2) / R2$

Design Current = 32A
45<OCP<50A

PL9201 change like CPU core power choke.

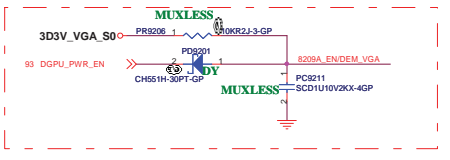
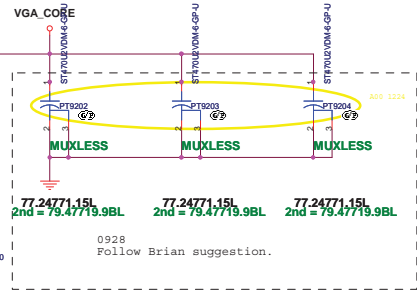

RT8208B

P-State	PWRCNTL_1 (GPIO6)	PWRCNTL_0 (GPIO5)	VGA_CORE_PWR
P0 (Cold)	L	L	0.975V
P0 (Hot)	L	H	0.954V (default boot up)
ES	H	L	0.878V
P8 & P12	H	H	0.853V

0923 update table

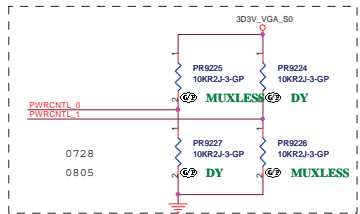

Frequency setting
 470K -->165KHz
 200K -->323KHz
 100K -->500KHz

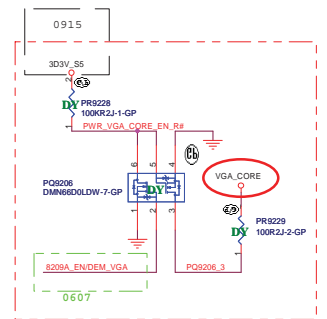
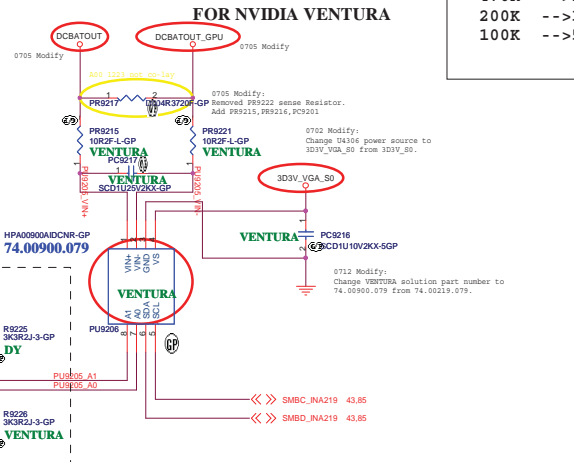

0928 Follow Brian suggestion.

0923 Update value of PR9210, PR9209 and PR9213 for N12P.

3D3V_S0 to 3D3V_VGA_S0 Transfer

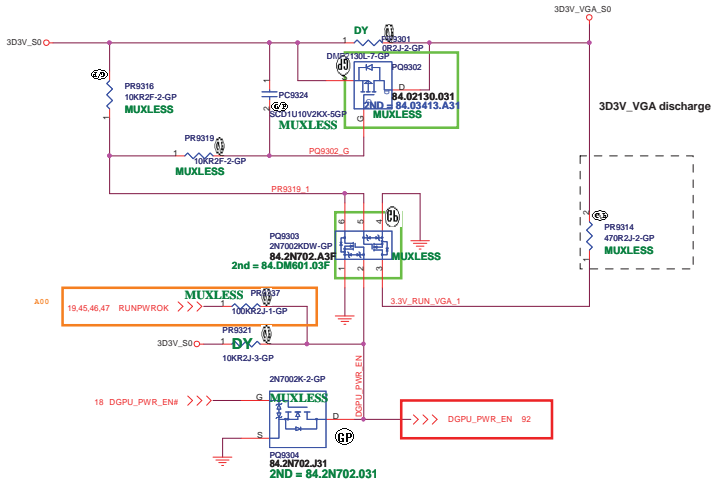

	DGPU_PWR_EN#
dGPU mode	L
IGPU	H
IGPU with BACO	L

NV do not need 1.8V

1D5V_VGA_S0

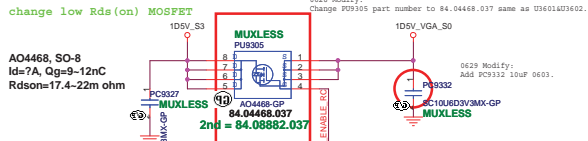

Park Madison Does Not Support BACO, So follow Old Sequence
Seymour_Whistler_Robson Support BACO, So Change Sequence

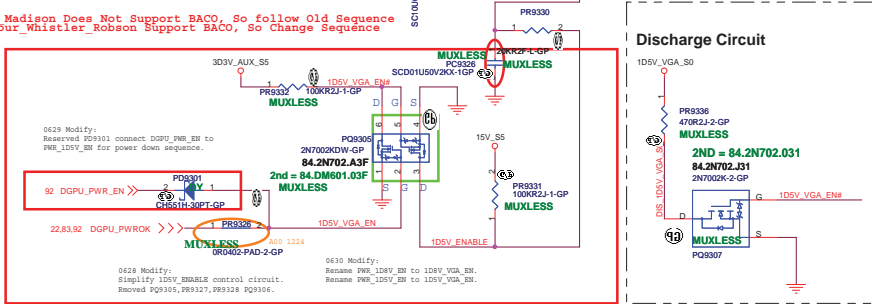

G9731F11U-GP for 1V_S0

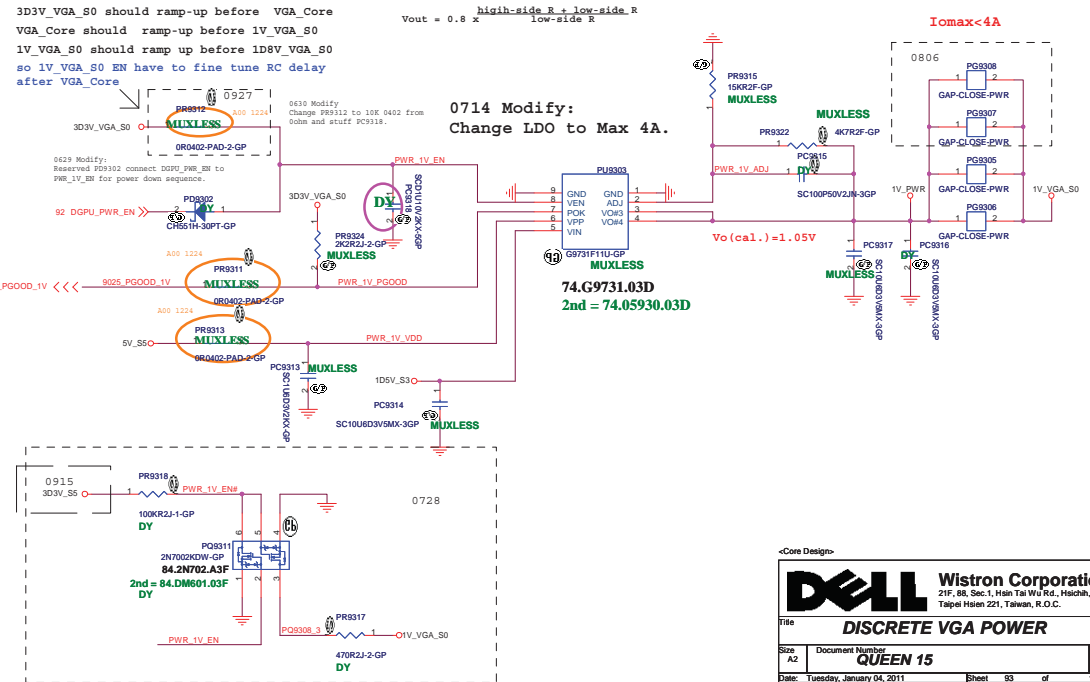

(Blanking)

<Variant Name>

		Wistron Corporation 21F, 88, Sec.1, Hsin Tai Wu Rd., Hsichih, Taipei Hsien 221, Taiwan, R.O.C.	
Title			
LVDS Switch			
Size	Document Number	Rev	
A3	QUEEN 15	A00	
Date:	Tuesday, January 04, 2011	Sheet	94 of 108

(Blanking)

<Variant Name>

		Wistron Corporation 21F, 88, Sec.1, Hsin Tai Wu Rd., Hsichih, Taipei Hsien 221, Taiwan, R.O.C.
Title		
CRT Switch		
Size	Document Number	Rev
A3	QUEEN 15	A00
Date: Tuesday, January 04, 2011	Sheet 95 of	108

SSID = SDIO

(Blanking)

<Variant Name>



Title		
TOUCH PANEL		
Size	Document Number	Rev
A3	QUEEN 15	A00
Date:	Tuesday, January 04, 2011	Sheet 96 of 108

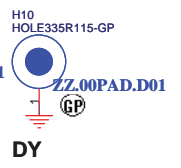
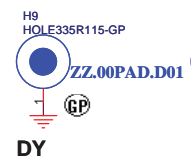
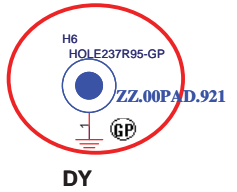
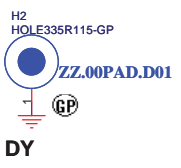

Check test point

0624 Modify:
Removed AFTP1,AFTP7-AFTP13.

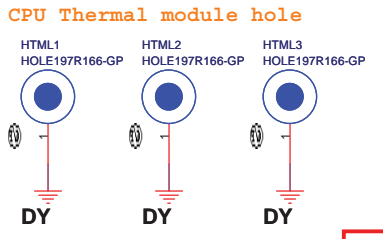
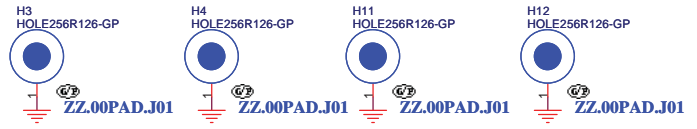

stand off

0721 Modify:
Removed SPR1

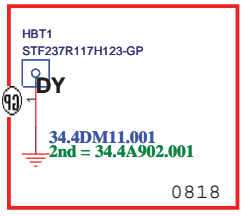
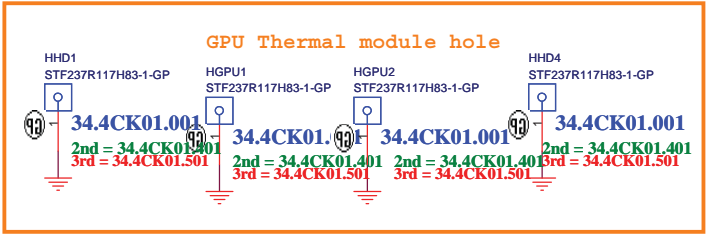
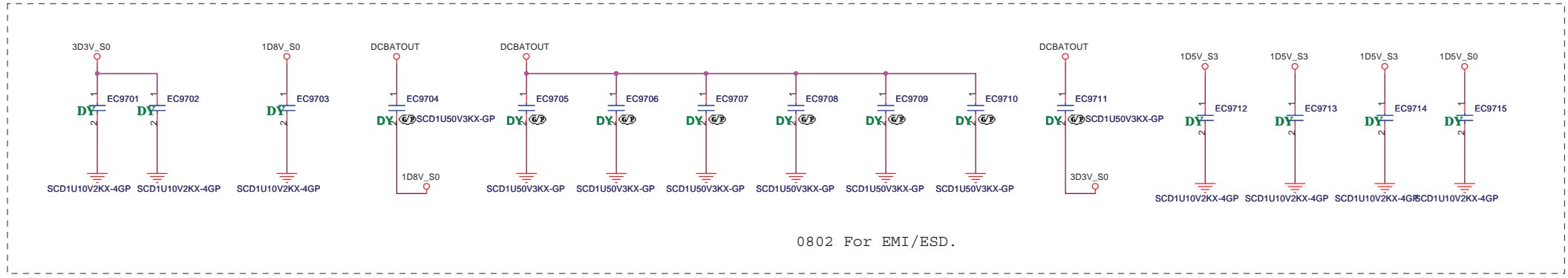
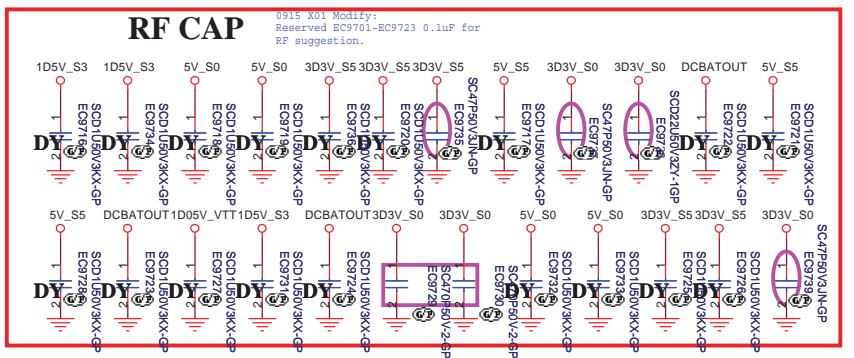
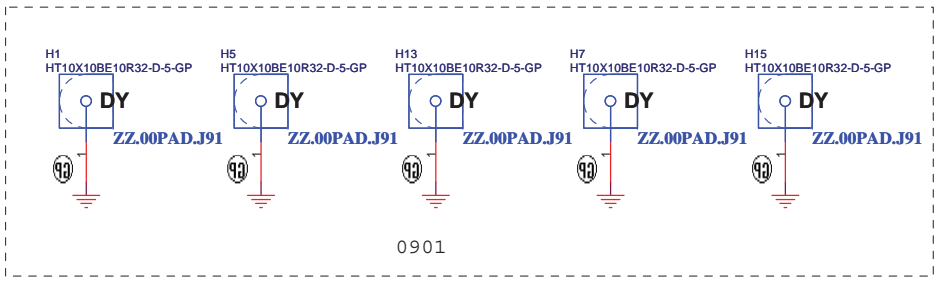

A00 0103 add 3rd LIDON(34.4CK01.501) on HDD1,HDD4,HGPU1,HGPU2 at XBuild batch run

<Variant Name>

Wistron Corporation
21F, 88, Sec.1, Hsin Tai Wu Rd., Hsichih,
Taipei Hsien 221, Taiwan, R.O.C.

Title
UNUSED PARTS/EMI Capacitors

Size A3 Document Number
QUEEN 15

Date: Tuesday, January 04, 2011 Sheet 97 of 108

Rev **A00**

Huron River Platform Power Sequence

(AC mode)

red word: KBC GPIO

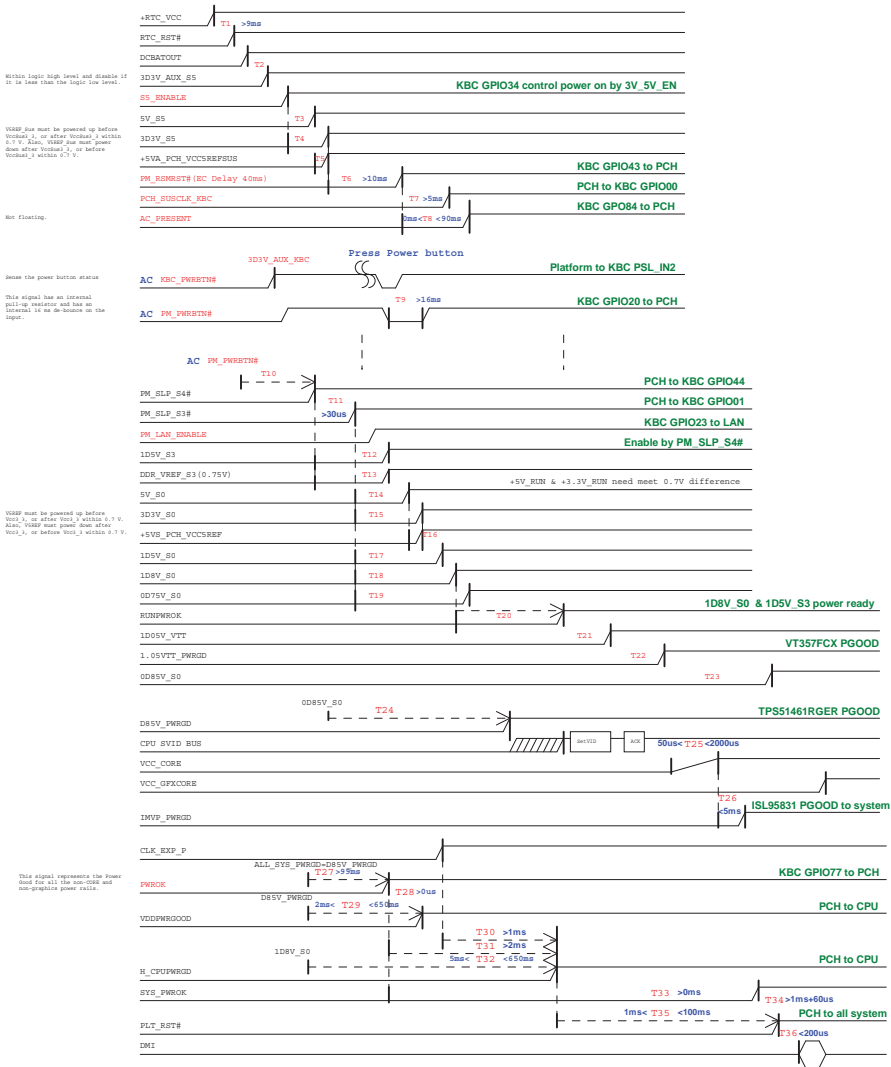

N12P-GE Power-Up/Down Sequence

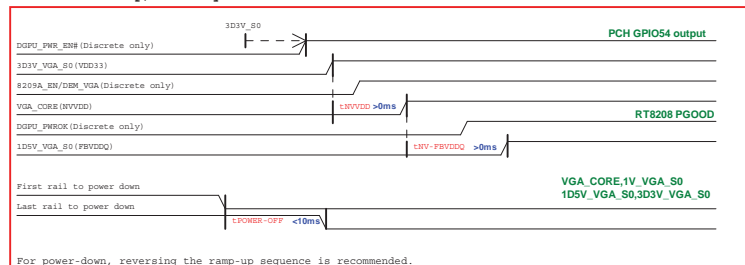

(DC mode)

red word: KBC GPIO

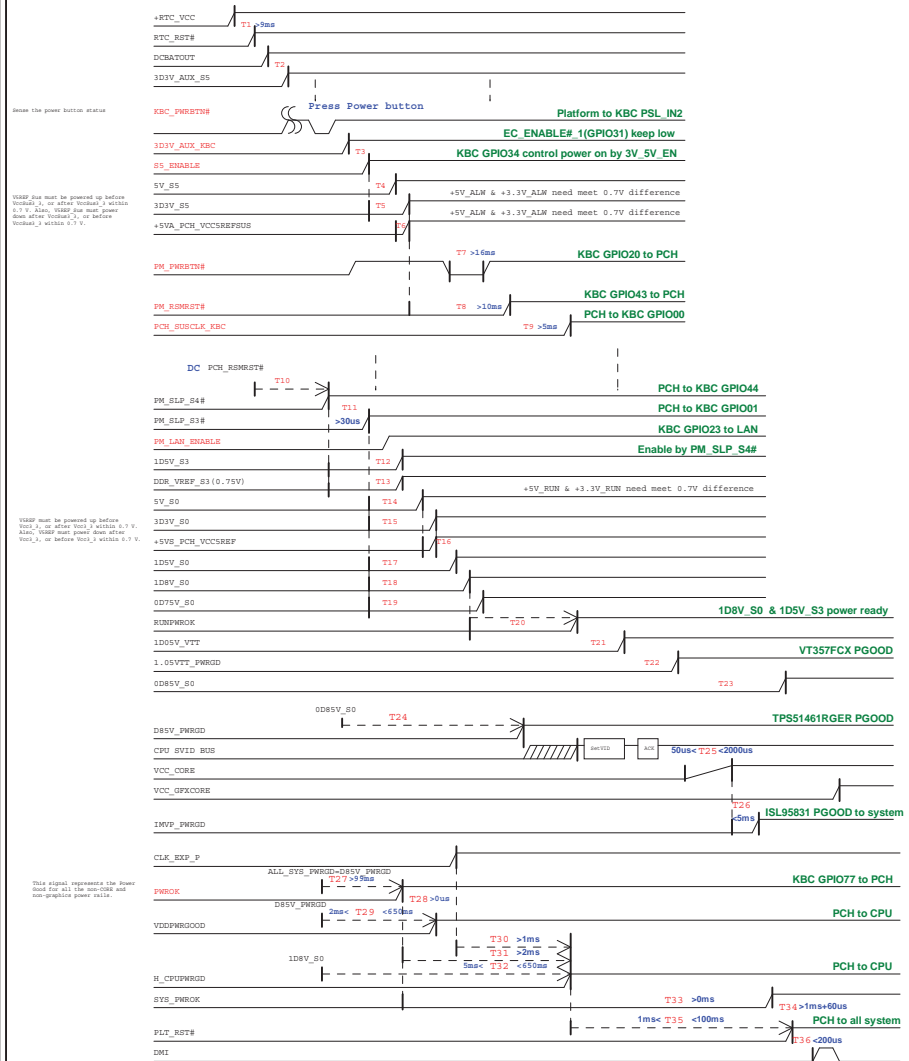

Wistron HURON RIVER POWER UP SEQUENCE DIAGRAM

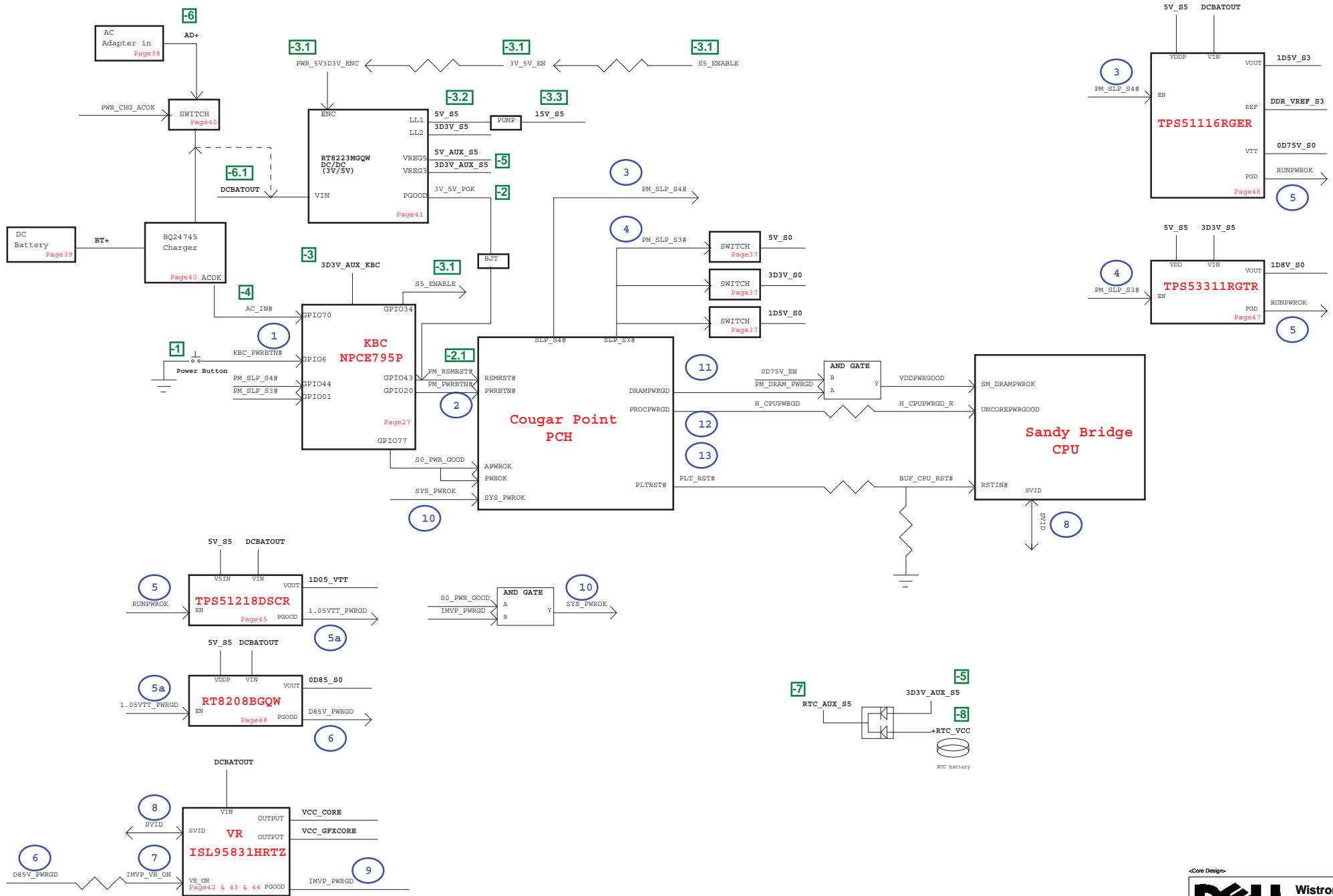

Power Up Sequence: **-8** ~ **13**

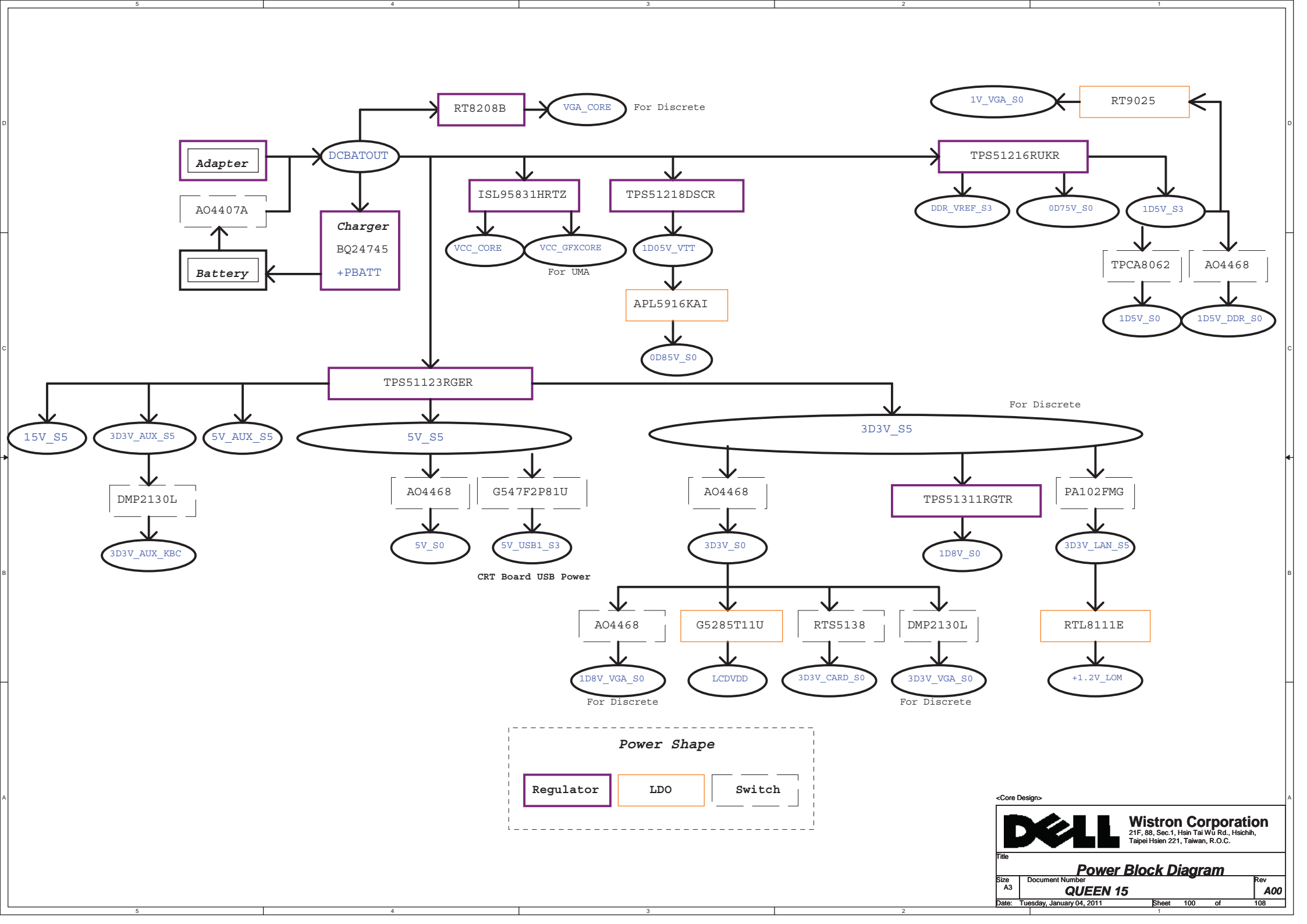

Power Shape

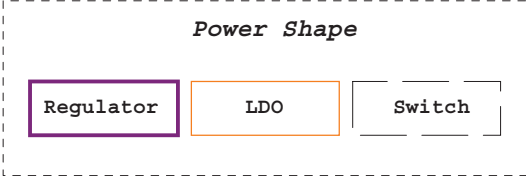

PCH SMBus Block Diagram

KBC SMBus Block Diagram

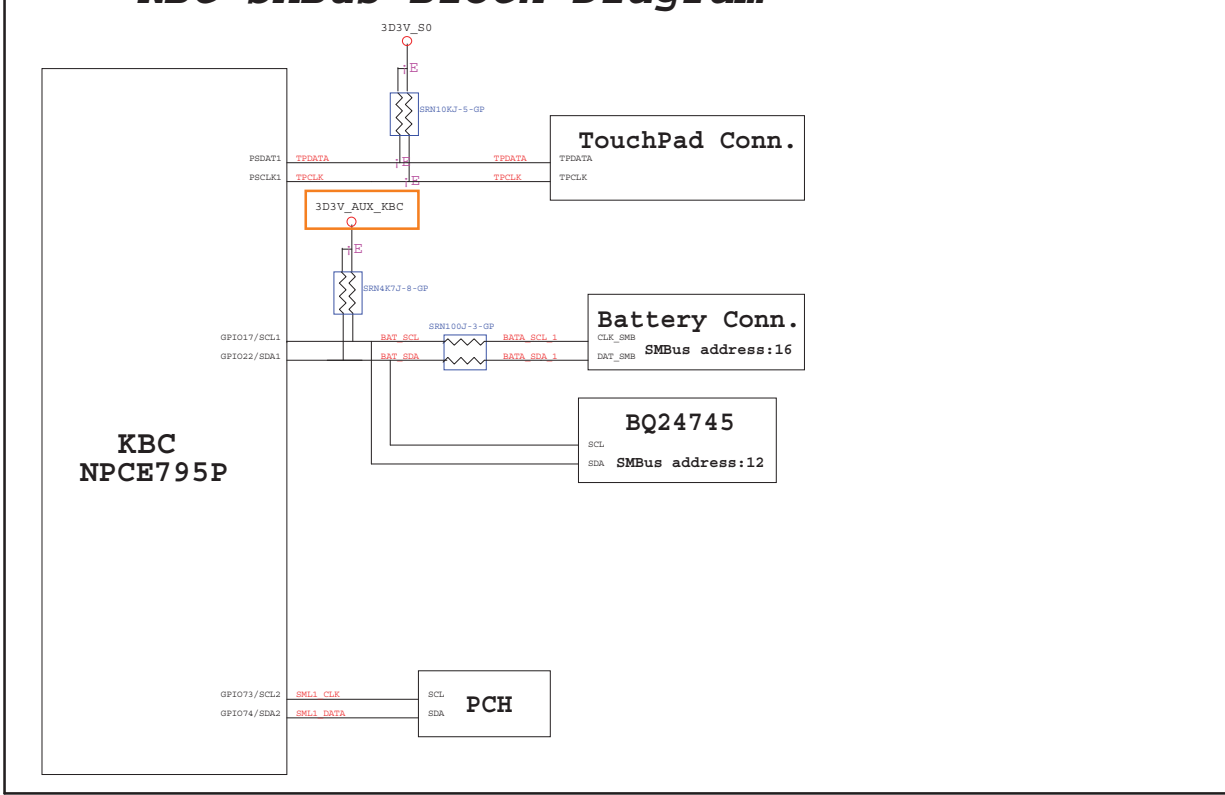
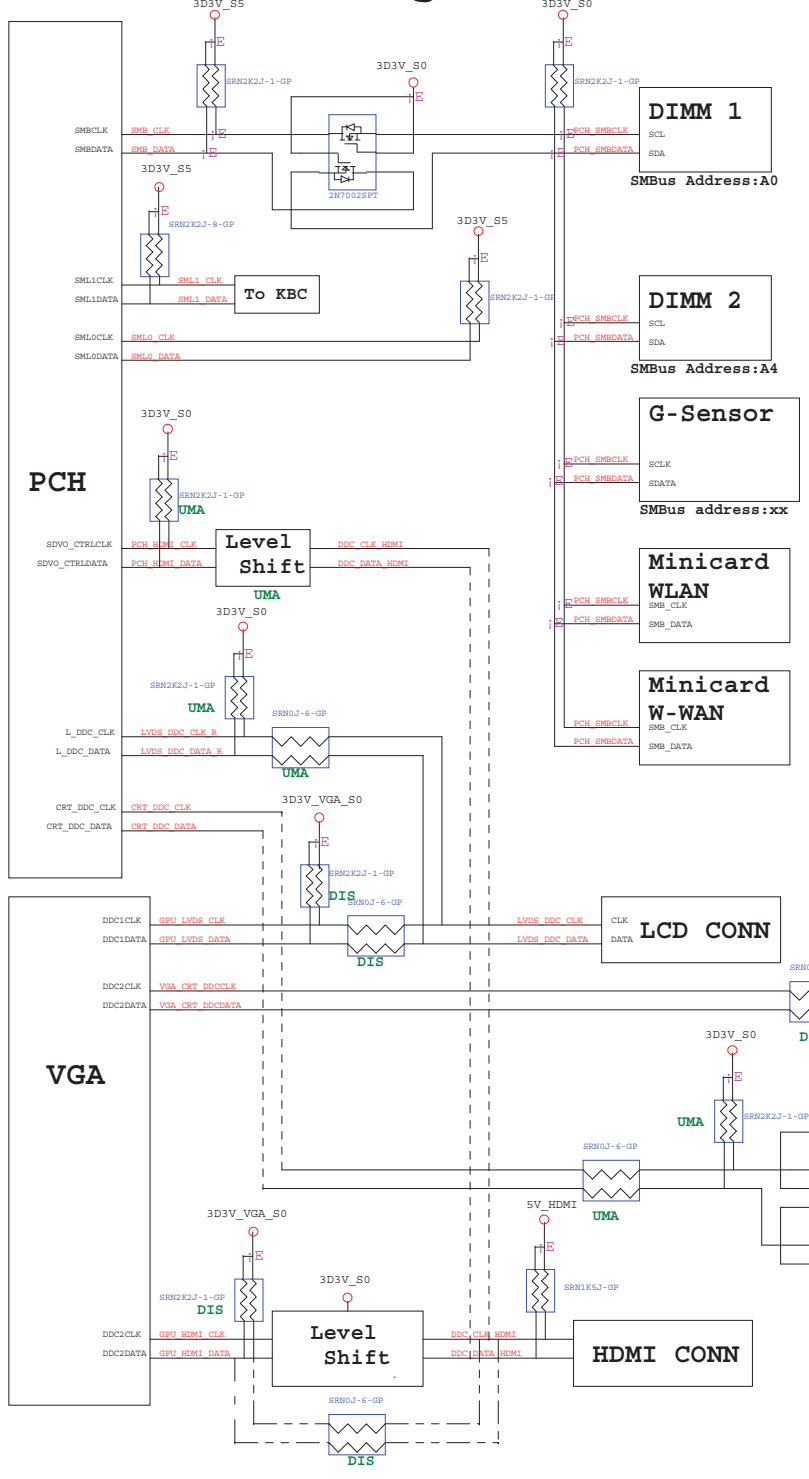

Thermal Block Diagram

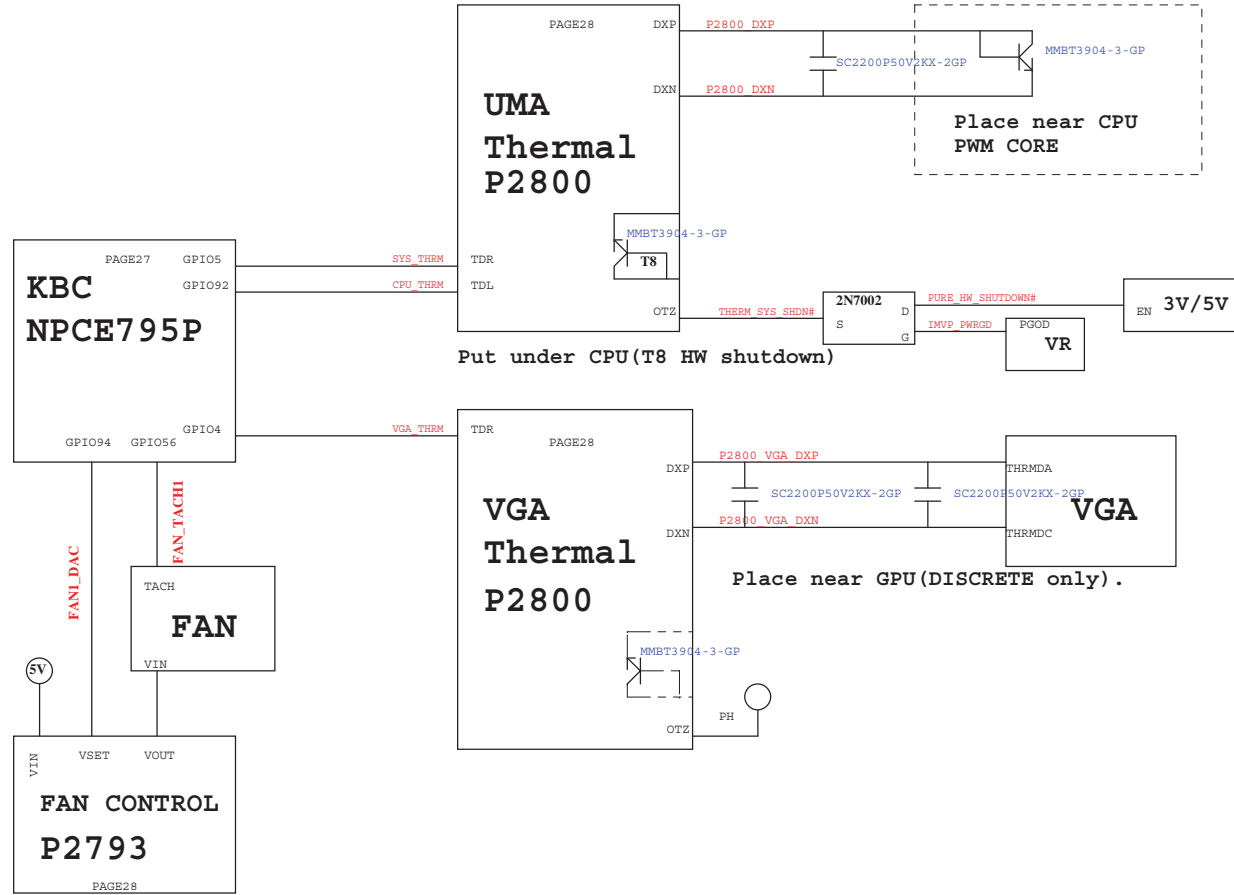

Audio Block Diagram

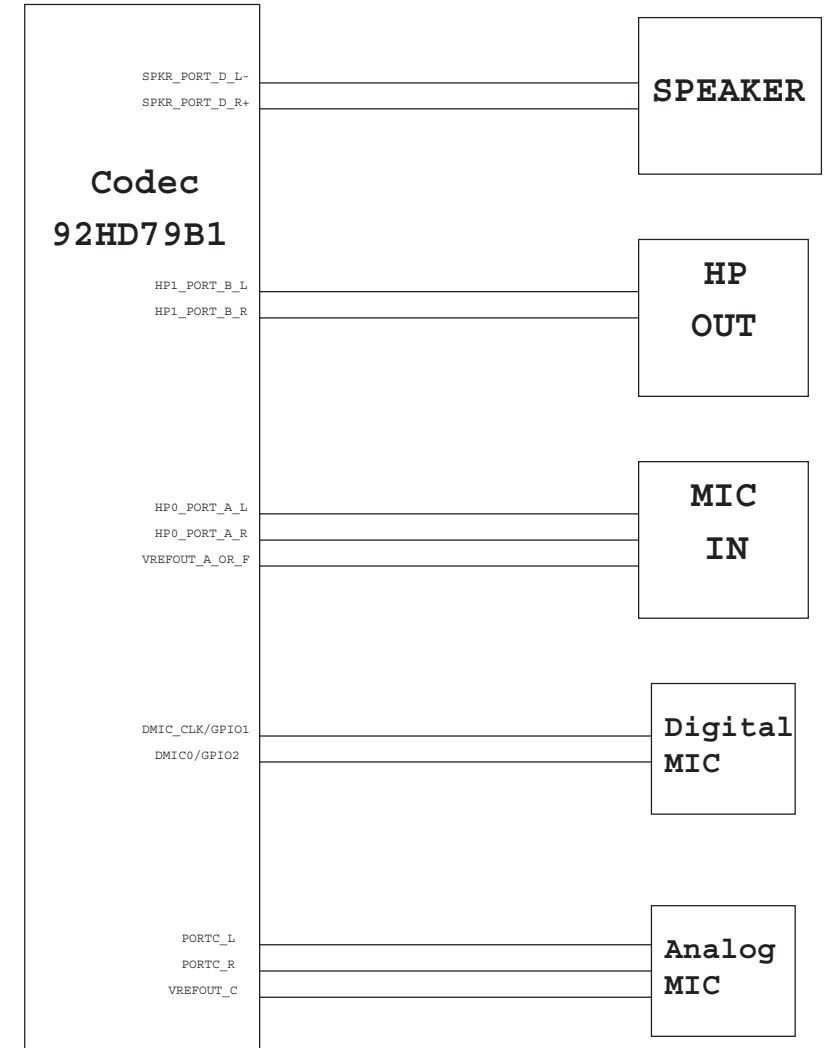

<Core Design>

VERSION	DATA	PAGE	Change Item
	08/25	14	SWAP SA0_DM1 and SA1_DIM1 each other for DM2 can't boot up issue.
	08/29	28	Change U2802 Main source to 74.00991.031, 2nd 74.02793.A31,3rd 74.05606.071
	08/29	61	Add 2nd 77.C1071.20L on TC6101.
	08/29	64	Re-assign FP1 pin define.
	08/29	71	Un-stuff Debug port connector(DB1) on X01.
	08/29	37	Change U3701 pin2 to RUNPWROK from 0D75V_EN. Reserved R3717 0ohm between PM_DRAM_PWRGD and VDDPWGOOD_R.
	08/29	37	Change R2724 to 20K 0402 from 10K for X01 stage.
	08/29	40	Change 3D3V_AUX_S5 to 3D3V_AUX_KBC to avoid leakage Voltage to 3D3V_AUX_KBC under DC mode.
	08/31	51	HDMI1 change to 22.10296.311 from 22.10296.271
	08/31	28	FAN1 change to 20.F0772.003 from 20.F1639.004
	08/31	57	E-SATA1 change to 22.10321.W11 from 22.10290.141
	09/01	41	PU4104 and PU 4105 horizontally mirror.
	09/01	83	R8305 Change to 30K ohm.
	09/01	97	H1, HS, H13, H7 and H15 change to ZZ.00PAD.J91 from ZZ.00PAD.D01.
	09/01	56	HDD1 add 2nd=62.10065.121.
	09/01	79	U7901 change main source to 74.00351.0B3.
	09/01	42	PR4226 change to 5.62K ohm.
	09/01	45	PTC4502 change to 79.3971V.30L.
	09/03	61	U6101 add 2nd=74.00547.079.
	09/03	49	U4901 add 2nd=74.09724.09F.
	09/03	40	PU4002 and PU4003 add 2nd=84.P1403.B37.
	09/03	24	L2401,L2402,L2403 add 2nd=68.10090.10B.
	09/03	27	DY C2713. Add C2722.
	09/03	47	Add PR4702
	09/03	22	Change FFS_INT2_R from PCH GPIO48 to GPIO15 Removed R2220 and change R2201 default pull up to pull down.
	09/06	20	X2001 add 3rd=82.30020.A31.
	09/06	56	U5601 add 2nd=74.02191.079.
	09/06	93	PU9303 add 2nd=74.05930.03D.
	09/06	37	U3701 add 2nd=73.7SZ08.DAH.
	09/06	23	Add 2nd and 3rd for L2301.
	09/06	23	R434 change name to PR9321. Add PC9324 and PR9319 for soft start.
	09/06	61	TC6101=80.10715.B1L, 2nd=77.C1071.21L, 3rd=77.C1071.20L.
	09/06	56	ODD1 add 2nd and 3rd source. HDD1 add 3rd source.
	09/06	49	LCD1 add 2nd source.
	09/06	69	TPAD1 add 2nd.

X01

VERSION	DATA	PAGE	Change Item
	09/06	15	DM1 2nd=62.10017.Q31, 3rd=62.10017.K01.
	09/06	14	DM2 2nd=62.10017.P31, 3rd=62.10017.K11.
	09/07	68	Add 2nd source 20.K0343.004 on PWRBTN1& PWRBTN2 base on updated connector list.
	09/07	69	Add 2nd source 20.K0343.004 on KBLIT1 base on updated connector list.
	09/07	82	Add 2nd source 20.F0085.040 on CRTBD1 base on updated connector list.
	09/07	64	Add 2nd source 20.K0382.006 on FP1 base on updated connector list.
	09/07	75	Add 2nd source 20.K0382.026 on NEW1 base on updated connector list.
	09/07	4-10	Updated CPU1 footprint to SKT-BGA989C470395-1H180 from SKT-BGA989C470395-1H186 base on data base updated. Add 2nd source 62.10040.771 on CPU1 base on updated connector list.
	09/07	75	Change CARD1 to 20.I0129.001 from 62.10051.931 from ME double updated latest DXF&EMN on X01.
	09/07	93	PQ9308 change name to PQ9311.
	09/07	ALL	Change all of single 2N7002 to 84.2N702.J31 from 84.2N702.D31 due to 84.2N702.D31 will EOL.
	09/07	28	Change U2801,U2803 to 74.02800.A71 from 74.02800.071 from vender updated parts. Change R2803&R2817 to 107K from 499K,R2804&R2818 to 226K from 102K base on updated ADJ Table.
	09/08	18, 22	Change FFS_INT2_R from PCH GPIO48 to GPIO14 Keep PCH_GPIO5 PH R2201,PCH_GPIO48 PH R2220. Add R1818.
	09/08	82	1.Rename IOBD1 pin20,22,26,28 to IOBD1_20,22,26,28 from PCIE_TXN5,PCIE_TXP5,PCIE_RXP5,PCIE_RXN5. 2.Add RN8207,RN8208 for optional USB3.0 PCIE or USB2.0 signal.
	09/08	18	Reserved USBP9-USBP10 to IOBD1 pin20,22,26,28.
	09/08	37	Stuff Q3704,R3710; un-stuff R3716. U3701 pin2 change to 1.05VTT_PWRGD from RUNPWROK.
	09/08	20	DY R2002.
	09/08	47	Mount PC4710.
	09/08	98	Update N12P power sequence.
	09/09	82	R8201, R8202 and R8203 change to 62 ohm.
	09/10	45	Change PL4501 to 68.2R210.20C from IND-D56UH-27-GP base on Brian updated.
	09/10	41	Change PL4101,PL4102 to 68.2R210.20B from 68.2R210.20Q base on Brian updated.
	09/10	82	Rename IOBD1 pin14 to IOBD1_14 from USB30_SMI#. Add R8207 for USB20 USB_OC#10_11 Add R8206 for USB30 USB30_SMI# Add R8208 for USB20 USB signal. Add R8207 for USB30 PCIE signal.
	09/10	49	Add TPNL1 for touch panel solution 4pin connector. Change LCD1 to 20.F1816.030 for 30pin Re-assign LCD1 pin define base on Roy updated cable pin define list.
	09/10	51	Change HDMI1 part number to 22.10296.331 from 22.10296.311 base on ME Double updated.

X01

<Core Design>

		Wistron Corporation 21F, 88, Sec. 1, Hsin Tai Wu Rd., Hsichih, Taipei Hsien 221, Taiwan, R.O.C.	
Change History			
Title			Rev
Size A3	Document Number QUEEN 15	A00	
Date: Tuesday, January 04, 2011	Sheet 103	of 108	

VERSION	DATA	PAGE	Change Item
	09/13	83	Change X8501 to 82.30034.641;2nd 82.30034.651;3rd 82.30034.681 from sourcer suggestion.
	09/13		Change KBLIT1, PWRBTN2 and TPAD1 2nd source from 20.K0343.004 to 20.K0382.004.
	09/13	47	Change 1.8V power solution.
	09/14	82	Change R8201-R8203 to 470ohm from 100ohm. Add RN8209 PH 5V_S5 on MEDIA_LED1-3# for PWM OD mode.
	09/14	40	Add 2nd source 84.04835.H37 on PU4002,PU4003 base on Brian updated 2nd source excel file.
	09/14	58	Change SPK1 to 20.F0772.004 from 20.F1647.004 from Double updated.
	09/14	51	Add R5101-R5108and reserved TR5101-TR5104 on all of HDMI differential pair for EMC suggestion. Rename HDMI1 CONN NET name.
	09/14	29	Add R2920,R2921 and reserved EC2901,EC2902 on AUD_DMIC_CLK &AUD_DMIC_IN0 for EMC suggestion.
	09/14	75	Add R7503,R7504 and reserved EC7501,EC7502 on CLK_PCIE_NEW &CLK_PCIE_NEW# for EMC suggestion. Rename NEW1 pin24,25 to USB_PP13_R&USB_PN13_R. Rename NEW1 pin8,9 to CLK_PCIE_NEW_C&CLK_PCIE_NEW#_C
	09/14	20	Reserved EC2004,EC2005 on CLK_PCIE_NEW &CLK_PCIE_NEW# for EMC suggestion.
	09/14	49	Reserved EC4910-EC4915 on LVDS signal for EMC suggestion.
	09/15	58	Re-assign SPK1 pin define base on Roy updated excel file for 20.F0772.004
	09/15	51	Add 2nd source 22.10296.311 on HDMI1 from updated connector list.
	09/15	68	Add 2nd source 20.K0382.004 on PWRBTN1& PWRBTN2 base on updated connector list.
	09/15	82	Re-assign CRTBD1 pin define base on EMC suggestion.
	09/15	49	Change BLON_OUT_C to pin 15 and pin 4 to NC on LCD1.
	09/15	28, 51,82	Add test point for WKS AFTE request.
	09/15	All	ADD 2nd source follow Power team suggestion.
	09/15	92, 93	Modify PR9318 and PR9228 power source from 3D3V_AUX_S5 to 3D3V_S5.
	09/15	86	Reserve Q8602, C8603 and R8606 for VGA over temp.
	09/15	20	RN2005 swap net.
	09/15	19	RN2005 swap net.
	09/15	48	Change PR4809 to 10K from 100K PH power source change to 3D3V_S0 from S5.
	09/15	82	Re-assign CRTBD1 pin define base on EMC suggestion.
	09/15	97	Reserved EC9701-EC9723 0.1uF for RF suggestion.
	09/15	41	Un-stuff PU4101,PD4105,PR4124, PR4125,PR4101 at X01 stage for 5mW issue.
	09/15	69	un-stuff R6907 and stuff R6905,Q6902,R6906 for 5V drive CAP LED.
	09/17	82	Change IOBD1 part number to 20.F1849.080 base on Double updated latest DXF&EMN.
	09/17	49,57 32,64	stuff TR4901 and un-stuff R4911,R4912 at X01 stage from EMC Neo suggestion. stuff TR4902 and un-stuff R4908,R4909 at X01 stage from EMC Neo suggestion. stuff TR5701 and un-stuff R5718,R5719 at X01 stage from EMC Neo suggestion. stuff TR3201 and un-stuff R3211,R3210 at X01 stage from EMC Neo suggestion. stuff TR6401 and un-stuff R6403,R6404 at X01 stage from EMC Neo suggestion.
	09/17	20	Change RN2010-RN2016 to 33ohm from 0ohm from EMC Neo suggestion.
	09/17	37	Change R3710 to 100K from 0ohm to avoid impact L05VTT_PWRGD turn off sequence directly.
	09/17	17	Add R1703-R1705 on RGB signal and reserved EC1701-EC1703 0.1u from EMC Neo suggestion.

VERSION	DATA	PAGE	Change Item
	09/17	40,41	Stuff EC4002 0.1uF from EMC Neo suggestion. Stuff EC4008 0.1uF from EMC Neo suggestion. Stuff EC4102,EC4103 0.1uF from EMC Neo suggestion. Stuff EC4107 0.1uF from EMC Neo suggestion. Stuff PC4119,PC4120 0.1uF from EMC Neo suggestion. Stuff EC4006,EC4007 0.1uF from EMC Neo suggestion.
	09/17	60,18	EC6001 change to 10p from 4.7p and default stuff from Neo suggestion. EC1801 change to 10p from 4.7p and default stuff from Neo suggestion.
	09/17	44	default stuff EC4407,EC4405,EC4403,EC4410 base on EMC Neo suggestion.
	09/17	49	Add 2nd source 20.F1561.004;3rd source 20.F1686.004 on TPNL1 from updated connector list.
	09/17	49	Add 2nd source 20.F1561.004;3rd source 20.F1686.004 on TPNL1 from updated connector list.
	09/17	82	Change R8201-R8203 to 430ohm.
	09/17	48	Change PR4809 to 4.7K from 100K PH power source change to 3D3V_S0 from S5.
	09/17	40,27,83	Rename PCIE_RST# to AD_IA_HW2 on KBC GPIO50 for power Tom suggest. Reserved PQ4004,PR4036,PR4037 for AD_IA_HW2 function.
	09/17	68	Rename CHARGER_LED1 to CHARGERLED1. Rename FPOWER_LED1 to FPOWERLED1. Rename HDD_LED1 to HDDLED1. Rename TP_LOCK_LED1 to TPLOCKLED1. Rename TP_LOCK_LED2 to TPLOCKLED2. Rename WLAN_LED1 to WLANLED1
	09/17	21,22	Base on layout routing,Add RN2104 10K instead of R2111 10K. Move EC_SCI#_DBC_EN to RN2201. Move S_GPIO to RN2103. Move PSW_CLR# to RN2104.
	09/17	56	Change R5605 to 100K from 10K and PH to 5V_S0 from 3D3V_S0 to meet Vgs>2V turn on.
	09/17	56	Add Q2706 2N7002 to avoid leakage loop from 3D3V_S5 to 3D3V_AUX_KBC issue when 10mW latched fail timing.
	09/17	ALL	Change all of 0402 0ohm to 0R0402 short pad. PR4008,PR4010,PR4012,PR4020,PR4023,PR4024,PR4027,PR4028,PR4029,PR4225,PR4102,PR4113,PR4118, PR4121,PR4203,PR4204,PR4215,PR4222,PR4231,PR4243,PR4301,PR4509,PR4510,PR4801,PR4804,PR4805, PR4808,PR4810,PR9211 F4902,PR4017,PR4018,PR4106,PR4611,PR4710,PR4807,R2304,R2403,R2406,R2409,R2702,R2902,R2903,R2904 R2305
	09/20	9	Add 2nd for TC901.
	09/20	83	Add 2nd for L8303.
	09/20	82	Add 2nd for LD8201.
	09/20	86	Add 2nd for Q8601.
	09/20	83	Add R8321. C8353 and C8354 change to 12pF.
	09/20	82	Redefine IOBD1.
	09/20	75	AFTP111 and AFTP110 connect to USB_PP13_R and USB_PN13_R.
	09/20	51	Change P/N of Q5102.
	09/21	42	Change PU4201 VDD power source to 5V_S5 from 5V_S0 to avoid abnormal MVP_PWRGD waveform.
	09/21	47	stuff PC4714 22uF from Brian updated.

X01

<Core Design>

		Wistron Corporation 21F, 88, Sec. 1, Hsin Tai Wu Rd., Hsichih, Taipei Hsien 221, Taiwan, R.O.C.	
Title			
Change History			
Size A3	Document Number QUEEN 15	Rev A00	
Date: Tuesday, January 04, 2011	Sheet 104	of	108

VERSION	DATA	PAGE	Change Item
X01	09/21	45	Change PR4507 to 20K from 20.5K from Brian updated.
	09/21	46	Change PR4602 to 110K from 68K from Brian updated.
	09/21	42	Change PR4217 to 1.27K from 1K from Brian updated. Change PR4213 to 3.6K from 3.16K from Brian updated. Change PR4236 to 3.01K from 3.32K from Brian updated.
	09/21	44	Change PC4410 to 0.01u from 0.022uF from Brian updated.
	09/21	39	Add 2nd 83.00099.K11;3rd 83.00099.T11 on D3901,D3902,D3903 from Sourcer Eden suggestion.
	09/21	39	Add 2nd 84.02143.011;3rd 84.00143.N11 on 6801,Q6804,Q6805,Q6806,Q6807,Q6808 from Sourcer Eden suggestion.
	09/21	43	Change PU4303,PU4306,PU4309 dummy field only for QC CPU stuff. Change PC4307,PC4316 dummy field only for QC CPU stuff. Add 2nd for PTC4306.
	09/21	41	PD4101, PD4103, PD4104 and PD4105 add 2nd source.
	09/21	69	Q6902 add 2nd source.
	09/21	40	PD4001 add 2nd source.
	09/21	19	move PCH_WAKE# to RN1901 pin4;Add R1909 PH 100K on AC_PRESENT.
	09/21	37	R3710 change to 0ohm. Remove R3701 and C3701.
	09/21	42	Add PR4214, PC4230, PR4216 and PC4231 from Brian updated.
	09/23	20	RN2016, RN2010, RN2011, RN2012, RN2014 and RN 2013 keep 0ohm.
	09/23	ALL	PR9216, R504, R1812,R1813,R1815,R1817, R1903, R1906,R1910,R1912,R1913,R1924,R1925, R2213,R2219, R2711,R2720,R2733,R2761, R2807,R2814, R3708, R5125, R5127, R5721, R5722.
	09/23	75	Add R7505-R7508 0ohm and reserved EC7503-EC7506 on PCIE_TX8&RX8 signal base on EMC Lance suggestion. Add R7509,R7510 0ohm and reserved EC7507,EC7508 on CLK_PCIE_NEW_REQ#&PCIE_WAKE# signal base on EMC Lance suggestion.
	09/23	ALL	RN5101, RN2201, RN1702, RN1901, RN1705 swap pin.
	09/23	79	DUMMY G-SENSOR.
	09/23	92	Update value of PR9210, PR9209 and PR9213 for N12P.
	09/23	43	PR4320 change to 4 m ohm.
	09/23	68	Add 2nd source 83.00110.J70 on FPOWERLED1,HDDLED1,WLANLED1 from Sourcer Anya suggestion. Add 2nd source 83.00326.G70 on CHARGERLED1from Sourcer Anya suggestion. Add 2nd source 83.00190.Z70 on TPLOCKLED1,TPLOCKLED2 from Sourcer Anya suggestion.
	09/23	69	Change KBLIT1 part number to 20.K0589.004 and re-assign pin define base on Roy updated.
	09/23	42, 44	Add 2nd source 69.60011.201 on PR4405,PR4245 from Sourcer Kitty suggestion.
	09/23	42	Add 2nd source 69.60037.021 on PR4246,PR4247 from Sourcer Kitty suggestion.
	09/24	23	Add 2nd source 68.00214.211 on L2301 updated from DN13ATI.
	09/24	68, 69	Change R6806,R6808,R6811-R6813,R6801,R6803,R6815,R6906 to 390ohm from 1K to fine tune all of MB LED for 5mA spec.
	09/27	51	Reserve R5114 and R5115.
	09/27	85	Reserve R8510 and R8513.
	09/27	83	DY U8301, mount R8323.
	09/27	92	R9206 change to 10K, PC9211 mount 0.1u.
	09/27	93	R9312 change to 1K.

VERSION	DATA	PAGE	Change Item
X01	09/27	49, 57 32, 64	TR4901, TR4902, TR5701, TR3201 and TR6401 DY. Stuff 0 ohm.
	09/27	69	AFTP73 connect to TP_VDD.
	09/27	85	U8501 power change to 3D3V_S0.
	09/27	92	PL9201 change like CPU core power choke.
	09/28	83, 84	L8303, L8401, L8402, L8502 and L8503 follow NV DG spec.
	09/28	46	Change PR4606 to 4.02K from 240ohm for fine tune 1.5V output Voltage.
	09/28	92	PTC9202, PTC9203 and PTC9204 2nd=79.47719.9BL
	09/28	22	Change R2220 to 10K from 100K.
	09/28	60	EC6001 change to 10p from 4.7p and default un-stuff from Neo suggestion. EC1801 change to 10p from 4.7p and default un-stuff from Neo suggestion
	09/28	27	Change R2710, R2739, R2724 and R2726 change to 1%.
	09/29	27	Default mount R2756, Dummy R2734.
	10/04	24	Add 2nd source 68.1001E.10N on L2401,L2402,L2403 from sourcer Renee Lee updated.
	10/07	43	PTC4306 cahnge second source to 79.47612.60L.
	10/09	85	Change L8503 to 68.00375.091,and add second source 68.00206.171
	10/09	85	Change L8502 to 68.00115.191,and add second source 68.00206.131
	10/09	84	Change L8401 and L8402 to 68.00115.181,and add second source 68.00206.341
	10/09	83	Change L8303 to 68.00375.101,and add second source 68.00119.101
	10/09	83	Change L8301 to 68.00115.161,and add second source 68.00206.111
	10/09	42	Change PR4217 to 64.84505.6DL for Dual-core OCP
	10/09	42	Change PR4213 to 64.23715.6DL for Dual-core loadline
	10/09	42	Change PR4207 to 64.22025.6DL for CPU(35W) Turbo setting
	10/09	42	Change PR4202 to 64.22025.6DL for GFX Turbo setting
10/09	20,83	Dummy R2004 R2003 and PQ8309, stuff R2005	
X02	10/19	28	Change R2817 from 107K to 124K (64.12435.6DL) for VGA temperature setting change
	10/25	84	Change R8402 from 40D2R to 60D4R (64.60R45.6DL) for meeting the spec
	10/25	14 15	Add DM1 and DM2 second source:62.10017.Q41 and 62.10017.P61
	10/25	85	Ventura SMB_C and SMBD_INA219_C add 3.3V pull high schematic
	11/01	51 85	Change HDMI HPD schematic for cost down
	11/10	27	Change R2724 to 64.33025.6DL for PCB version change
	11/10	83	Change L8301 to 68.00115.181,and add second source 68.00206.341

<Core Design>



Title			Change History		
Size	Document Number	Rev			
A3	QUEEN 15	A00			
Date:	Tuesday, January 04, 2011	Sheet	105	of	108

VERSION	DATA	PAGE	Change Item
	11/11	14	DM2 1st change to 62.10017.P61; 2nd change to 62.10017.N41 on ST stage from ME updated connector list.
	11/11	15	DM1 1st change to 62.10017.Q41; 2nd change to 62.10017.N11 on ST stage from ME updated connector list.
	11/11	60	U6001 1st change to 72.25Q32.A01; 2nd change to 72.25320.C01; 3rd change to 72.25P32.C01 on ST stage
	11/11	68	Change CHARGERLED1 2nd to 83.00327.D70 from Sourcer updated.
	11/11	37	Change U3701 1st to 73.7SZ08.EAH;2nd to 73.01G08.L04;3rd to 73.7SZ08.DAH from Sourcer Eason updated.
	11/11	69	Add 2nd 20.K0592.030 on KB1 from ME updated connector list.
	11/11	82	Add 2nd 20.K0465.008 on MEDIA1 from ME updated connector list.
	11/11	58	Add 2nd 20.F1804.004 on SPK1 from ME updated connector list.
	11/11	28	Add 2nd 20.F1841.003 on FAN1 from ME updated connector list.
	11/11	70	Add 2nd 20.F0962.010 on HALL1 from ME updated connector list.
	11/11	23	Add G9091 LDO circuit for CRT DAC power to avoid monitor noise issue. Change VCCADAC power source to 3D3V_DAC_S0 from 3D3V_S0.
	11/11	60	Add Q6002,R6007 fo FACTORY RTC detect function
	11/11	28	ADJ&ADJ_VGA power source change to 3D3V_DAC_S0 from 3D3V_S0 to solve T8 shut down issue.
	11/11	28	Reserved G709T1UF for T8 solution sync with DN13.
	11/12	82	Change R8201, R8202, R8203 from 430 ohm to 1K ohm (63.10234.IDL) for soluting media board LED brightness is too light issue
	11/15	49	Add 2nd 20.F1860.030 on LCD1 from ME updated connector list.
	11/15	8	Reserved C802~C804,C806,C807 10uF 0603 for power team fine tune Vcore quality
	11/15	88 89 90 91	All of VRAM(VRAM1~VRAM8) PCB footprint change to CO-LAY type (DUMMY-BGA96D075133H48) from BGA96D0913H48 same as DW30.
	11/15	68 69	Change R6813, R6906 from 390 ohm to 1K ohm (63.10234.IDL) for soluting LED brightness is too light issue
	11/15	20	Dell required us to disable PCIE port of WWAN slot ,If PCIE port 1 is disabled, it will cause all PCIE port disabled,so change WWAN to PCIE port 3 from port1 at ST stage.
	11/16	97	Change HHD1 HDD4 HGPU1 HGPU2 2nd from 34.4CK01.201 to 34.4CK01.401 from ME update connector list
	11/16	68	Change R6808, R6811 from 390 ohm to 1K ohm (64.10234.IDL) for soluting LED brightness is too light issue
	11/16	28	stuff both G709T1UF and P2800 related circuit, add R2805 0ohm default un-stuff at ST stage.
	11/17	48	CO-LAY APL5916 related circuit for VCCSA LDO solution.
	11/18	23	Add G9091 LDO circuit for CRT DAC power to avoid monitor noise issue. Change VCCADAC power source to 3D3V_DAC_S0 from 3D3V_S0. Stuff R2301 and un-stuff L2301.
	11/18	28	Add R2805 0hm between THERM_SYS_SHDN#_OTZ and THERM_SYS_SHDN#. Add R2812 0ohm between THERM_SYS_SHDN# and U2805 pin3.

X02

VERSION	DATA	PAGE	Change Item
	11/18	28	Rename U2801&U2804 pin 8 to THERM_SYS_SHDN#_OTZ from HERM_SYS_SHDN#.
	11/18	20	Change X2001 to 82.30020.D41 from 82.30020.851 from Sourcer Dick updated.
	11/18	23	Reserved R2308,R2309 on VCCVRM power rail.Reserved U2302 LDO circuit on VCCVRM power rail
	11/18	22 82	Rename USB3_PWR_ON to PCH_GPIO57. Add R8209,R8210 for PM_SLP_S4# and VGA_THRM to control USB3_PWR_ON
	11/18	48	Change PTC4801 to 100u(77.21071.07L) from 150u from power team Brian updated
	11/19	74	Add 2nd 20.I0135.001 on CARD1 from ME updated connector list.
	11/19	82	Add 2nd 20.F1908.080 on IOBD1 from ME updated connector list.
	11/20	3	Updated PCIE ROUTING
	11/20	28	Change U2801,U2804,U2805 VCC power to 3D3V_DAC_S0 from 3D3V_S0. Stuff R2812, un-stuff R2805
	11/20	23	Reserved R2308 on VCCVRM power rail. Reserved U2302 LDO circuit on VCCVRM power rail.
	11/20	48	Set TPS51461 PWM solution dummy field for VCCSA_PWM and APL5916 LDO solution dummy field for VCCSA_LDO. default stuff VCCSA_LDO at ST stage
	11/20	22	Rename GFX_CRB_DET to GSENSOR_DET on GPIO39.
	11/20	60	Un-stuff R6007 10M.
	11/20	82	Reserved EC8201,EC8202 0.1u(closed H3) between AGND and GND from EMC Neo suggestion.
	11/20	82	Reserved EC8203~EC8205 470p on all of MEDIA_LED# signal from EMC Neo suggestion.
	11/20	82	Add RN8205 base on HSYNC&VSYNC report
	11/20	61	Removed R6101 and connect USB_PWR_EN# to U6101 pin4 directly.
	11/20	22	Rename PCH_GPIO12 to RTC_DET# on GPIO12.
	11/20	61 22 18	Reserved U6102 USB POWER related circuit to separate EATA and CRT USB power in ST build. Reserved USB2_CRT_ON# to control U6102 USB power switch from PCH GPIO57. Reserved USB_OC#0_1 connect from PCH GPIO59.
	11/20	82	Reserved R8211,R8212 0ohm 0805 on CRTBD1 pin37,39 to separate EATA and CRT USB power in ST build.
	11/22	82	Swap RN8205 pin4,3 and pin2,1 each other base on Connie swap report.
	11/22	82	stuff EC8201,EC8202 0.1u(closed H3) between GND and GND from EMC Neo suggestion. stuff EC8206 between 3D3V_S5 and GND from EMC Neo suggestion.
	11/22	23	base on layout condition change 3D3V_DAC_S0 circuit. Stuff R2301 and un-stuff L2301.
	11/22	82	stuff EC8203~EC8205 470p on all of MEDIA_LED# signal from EMC Neo suggestion.
	11/22	23	Removed U2302 LDO for VCCVRM.

X02

<Core Design>

		Wistron Corporation 21F, 88, Sec.1, Hsin Tai Wu Rd., Hsichih, Taipei Hsien 221, Taiwan, R.O.C.	
Change History			
Title	Document Number		Rev
	QUEEN 15		A00
Date:	Tuesday, January 04, 2011	Sheet	106 of 108

VERSION	DATA	PAGE	Change Item
	11/22	29	change R2920,R2921 to 22ohm from 0ohm and stuff EC2901,EC2902 22p from EMC Neo updated.
	11/22	61	Change U6101 to dual USB power switch from single for Layout limitation and placement. Reserved USB2_CRT_ON# to control U6102 USB power switch from PCH GPIO57. Reserved USB_OC#0_1 connect from PCH GPIO59.
	11/22	49	stuff C4908 0.1uF from EMC Neo suggestion.
	11/22	57	Change TR5701 to 69.10103.041 and un-stuff R5718,R5719 from EMC Neo Suggestion.
	11/22	49	Change TR4902 CM choke to 69.10103.041 and un-stuff R4908,R4909 from EMC Neo Suggestion.
	11/22	49	Swap TR4901 pin4,3 and pin2,1 each other base on Connie swap report. Change TR4901 CM choke to 69.10103.041 and un-stuff R4911,R4912 from EMC Neo Suggestion.
	11/22	75	Change TR7501 CM choke to 69.10103.041 and un-stuff R7501,R7502 from EMC Neo Suggestion.
	11/22	58	stuff EC5801-EC5804 470pF from EMC Neo suggestion.
	11/22	9 39 45 49	stuff EC901, EC3903, EC4501, EC4909, EC4907 0.1uF from EMC Neo suggestion.
	11/22	49	Change RN4901 to 100ohm 4p from 8p for improve layout place.
	11/22	48	Updated VCCSA_LDO circuit from Power team Brian updated.
	11/22	83 84 85	Change L8301 L8401 L8402 to 0 ohm resistor (63.00000.00L)
	11/22	60	stuff R6007 10M.
	11/23	49 57 75	SWAPTR4901 TR4902 TR5701 TR7501 pin1&4 and pin2&3 each other base on Connie swap report.
	11/23	60	Change U6101 1st(74.02182.071);2nd(74.00546.A7D);3rd(74.02062.079) from Sourcer Harrison suggestion.
	11/23	64	Add C6402 0.1uF,C6403 180pF and stuff C6401 47pF from RF fine tune result.
	11/23	57 49 75	Change R5718,R5719,R4908,R4909,4911,R4912,R7501,R7502 to 0ohm 0603 from 0402.
	11/23	56 97	stuff EC9739,EC9737,EC9735 47pF from RF fine tune result. stuff EC5601 180pF from RF fine tune result. Stuff EC9738 0.22uF closed EC9739 from RF fine tune result.
	11/23	97	stuff ECEC9729,EC9730 470pF from EMC Neo suggestion.
	11/23	45	Change PR4501 to 75K from 45.3K for 1.05V OCP set to 20A from Brian.
	11/23	82	Removed R8211,R8212 and connect 5V_USB2_S3 to CRTBD1 pin 37 directly.
	11/23	61	Removed C6105,C6103.
	11/23	69 70	Change AFTP 80 81 to AFTP 83 84; change AFTP 83 to AFTP82; change AFTP 82 to AFTP85.
	11/24	20	Add 2nd(82.30020.G71);3rd(82.30020.G61) on X2001 from Sourcer Dick updated.
	11/24	69	Add 2nd(20.K0613.004)on KBLIT1 from Karl updated.

X02

VERSION	DATA	PAGE	Change Item
	11/24	57	Add 2nd(22.10339.261)on ESATA1 from Karl updated.
	11/24	28	un-stuff VGA P2800 related circuit from Niki confirmed.
	11/24	64	rename C6401,C6402,C6403 to EC6401,EC6402,EC6403
	11/24	22	Dummy R2206
	11/25	28	Dummy R2817 R2818 C2816
	11/25	69	Add 3rd(83.00110.R70) on FPOWERLED1,HDDLED1,WLANLED1 from Anya provide
	11/25	69	Add 3rd(83.00192.J70) on TPLOCKLED1 and TPLOCKLED2 from Anya provide.
	11/25	69	Add 3rd(83.01108.070) on CHARGERLED1 from Anya provide.
	11/26	43 92	Change PC9217 PC4319 to 0.1u 50V
	11/29	83	Change C8353 C8354 to 15PF ,R8320 stuff from vendor suggestion.
	11/29	36	Stuff D3602
	11/30	68	Change 2nd source to 83.00322.070 from 83.00110.J70
	11/30	85	Change L8502 L8503 to 0 ohm
	11/30	92	Stuff PR9237 DY PR9321
	12/01	8	Change C837,C826 to 22uF from 10uF and default stuff from Power Brian updated.
	12/01	8	Change C801-C807 and C817 10uF stuff at QC CONFIG from power Brian updated.
	12/21	ALL	Change 0402 pad(ZZ.00PAD.M11): R1404 R1405 R1503 R1504 R1703 R1704 R1705 R1807 R2301 R2306 R2307 R2308 R2404 R2405 R2735 R2737 R2758 R2759 R2760 R2762 R3614 R3710 R5114 R5801 R5802 R5803 R5804 R8210 R8323 R8511 R8512
	12/21	82	Change 0603 pad(ZZ.00PAD.M21): R8206 R8207
	12/21	17 20	Change resistor pad(ZZ.0R04P.ZZZ): RN1704 RN2010 RN2011 RN2012 RN2013 RN2014 RN2015 RN2016
	12/21	83 84 85	Change L8301, L8401,L8402,L8502,L8503 to 0R0603 pad(ZZ.00PAD.M21)
	12/21	ALL	Change to Parallel resistor R1501 ,R1502; R2739 ,R2774;R8202 ,R8203;R8501 ,R8502;R8506 ,R8507;R2123 ,R2124
	12/21	82	RN8205 change to R8201, R8202
	12/21	93	PR9237 rename to PR9337
	12/21	56 61 68	Delete 77.C1071.21L(TC6101), delete 83.01108.070(CHARGERLED) , delete 62.10065.121(HDD1)

A00

<Core Design>

		Wistron Corporation 21F, 88, Sec. 1, Hsin Tai Wu Rd., Hsichih, Taipei Hsien 221, Taiwan, R.O.C.	
Title			
Change History			
Size A3	Document Number QUEEN 15	Rev A00	
Date: Tuesday, January 04, 2011		Sheet 107	of 108

VERSION	DATA	PAGE	Change Item
	12/22	27	R2724 change to 47K resistor for XBuild
	12/22	27	R2301 change to 0 resistor for CRT debug
	12/22	40	1.Change PR4032,PR4034,PR4037 to ZZ.00PAD.M11 2.Stuff PQ4003,PQ4004 3.Change PR4047 to 174K(64.17435.6DL) 4.Change PR4035 to 300K(64.30035.6DL) 5.Change PR4036 to 76.8K(64.76825.6DL) 6.Change PR4031 to 150K(64.15035.6DL)
	12/23	68	1.FPOWERLED1 rename to FPLED1 2.HDDLED1 rename to HDLED1 3.CHARGERLED1 renamtp to CHLED1 4.WLANLED1 rename to WLED1 5.TPLOCKLED2 rename to TPLED2 6.TPLOCKLED1 rename to TPLED1 7.PWRBTN1 rename to PWRBT1 8.PWRBTN2 rename to PWRBT2
	12/23	43	Delete PR4323,PR4324,PR4325; Stuff PR4320 for all BOM ,not co-lay Ventura
	12/23	92	Delete PR9220,PR9222,PR9223; Stuff PR9217 for all BOM ,not co-lay Ventura
	12/23	51	Change 5V_HDMI to 5V_CRT_S0_R for HDMI power leakage
	12/24	All	PRN3901 rename to PN3901 PTC9202-04 rename to PT9202-04 PTC4301-04 rename to PT4301-04 PTC4306 rename to PT4306 PTC4308-09 rename to PT4308-09 PTC4401-03 rename to PT4401-03 PTC4502 rename to PT4502 PTC4602 rename to PT4602 PTC4102 rename to PT4102 PTC4104 rename to PT4104
	12/24	28	Change U2802 3rd to 74.05606.A71 at X-Build batch run
	12/24	82	Change RN8205 to 66.22036.04L from 66.22036.040at X-Build stage
	12/24	82	Reserved R8211 0603 0ohm on F8201
	12/24	36	Reserved Q3603 2N702 on IMVP_PWRGD to fine tune glitch waveform when AC lose and DC lose.
	12/24	28	Change 3D3V_S0 to 3D3V_DAC_S0
	12/24	45 46 93	Change to short pad: PR4502,PR4607,PR9311,PR9312,PR9326. DUMMY PC4501
	12/27	28	If stuff P2800EA1 then must stuff R2803,R2804,C2805 but if stuff P28003B0 should be unstuff.
	12/27	42	PR4207,PR4213,PR4217 DUMMY field set to DC&QC option
	12/28	51	Change 5V_HDMI to 5V_CRT_S0_R on RN5101
	12/28	28	Un-stuff U2805 G709T1UF related circuit and R2812 then stuff R2805 at XBuild

A00

VERSION	DATA	PAGE	Change Item
	12/28	27	Change R2756, R2763, R2766 to short pad
	12/28	36	Stuff Q3603
	12/28	28 86	Cancel VGA Thermal sensor P2800 circuit
	12/28	27 28 82	Change to VGA_THRM to USB3_PWR_ON
	12/28	23	Change R2301 to short pad
	12/29	51	Change HDMI resistor to short pad
	12/29	49,57,75	Delete USB DUMMY resistor for no-lay
	12/29	32	Change USB 0 resistor to short pad for no-lay
	12/29	5	Reserve EC502 ,EC504 for EMI suggestion,add DUMMY EC505 for EMI
	12/29	82	Delete PM_SLP_S4# line, directly link to USB3_PWR_ON
	12/29	23	Add 3rd Richtek(74.09198.G7F) on U2301 at XBuild batch run config
	12/29	68	Not use Liteon LED(83.00322.070) for package
	12/30	5	Add DUMMY diode EC506 for BUF_CPU_RST# as EMI suggestion
	12/30	42	PC4227 change to 78.33420.5FL as 78.33423.5FL obsoleted
	12/30	49	Change R4904 to short pad
	12/31	86	Add probe point for P2800_VGA_DNX/P2800_VGA_DXP
	01/03	68	Change TPLED1,2 1st to 83.01921.P70 ,2nd to 83.00190.S7A,3rd to 83.00191.H70; R6813 change to 390R from 1K same as DN13 LED part.
	01/03	49	Delete R4908, R4909 for USB_Camera not co-lay
	01/03	4-10	Add 3rd foxconn(62.10055.321) on CPU1 at X-Build batch run config
	01/03	82	Add 3rd T-conn(20.F1932.040) on CRTDB1at X-Build batch run config
	01/03	97	Add 3rd LIDON(34.4CK01.501) on HHD1,HHD4,HGPU1,HGPU2 at X-Build batch run config
	01/04	68	Delete 83.00191.H70 for TPLED1,2 as cost high
	01/04	49,57,75	Add 2nd TAI-TECH(69.10084.071) on TR4901,TR4902,TR5701,TR7501 at X-Build batch run config

A00

<Core Design>

		Wistron Corporation 21F, 88, Sec.1, Hsin Tai Wu Rd., Hsichih, Taipei Hsien 221, Taiwan, R.O.C.	
Title Change History			
Size A3	Document Number QUEEN 15		Rev A00
Date: Tuesday, January 04, 2011		Sheet 108 of	108