

# DIS (14" / 15" / 17") S-Vine<sup>MT</sup> Intel Crescent Bay ULT Platform Block Diagram

01

PCB 6L STACK UP

LAYER 1 : TOP  
 LAYER 2 : SGND  
 LAYER 3 : IN1(High)  
 LAYER 4 : IN2(Low)  
 LAYER 5 : SVCC  
 LAYER 6 : BOT

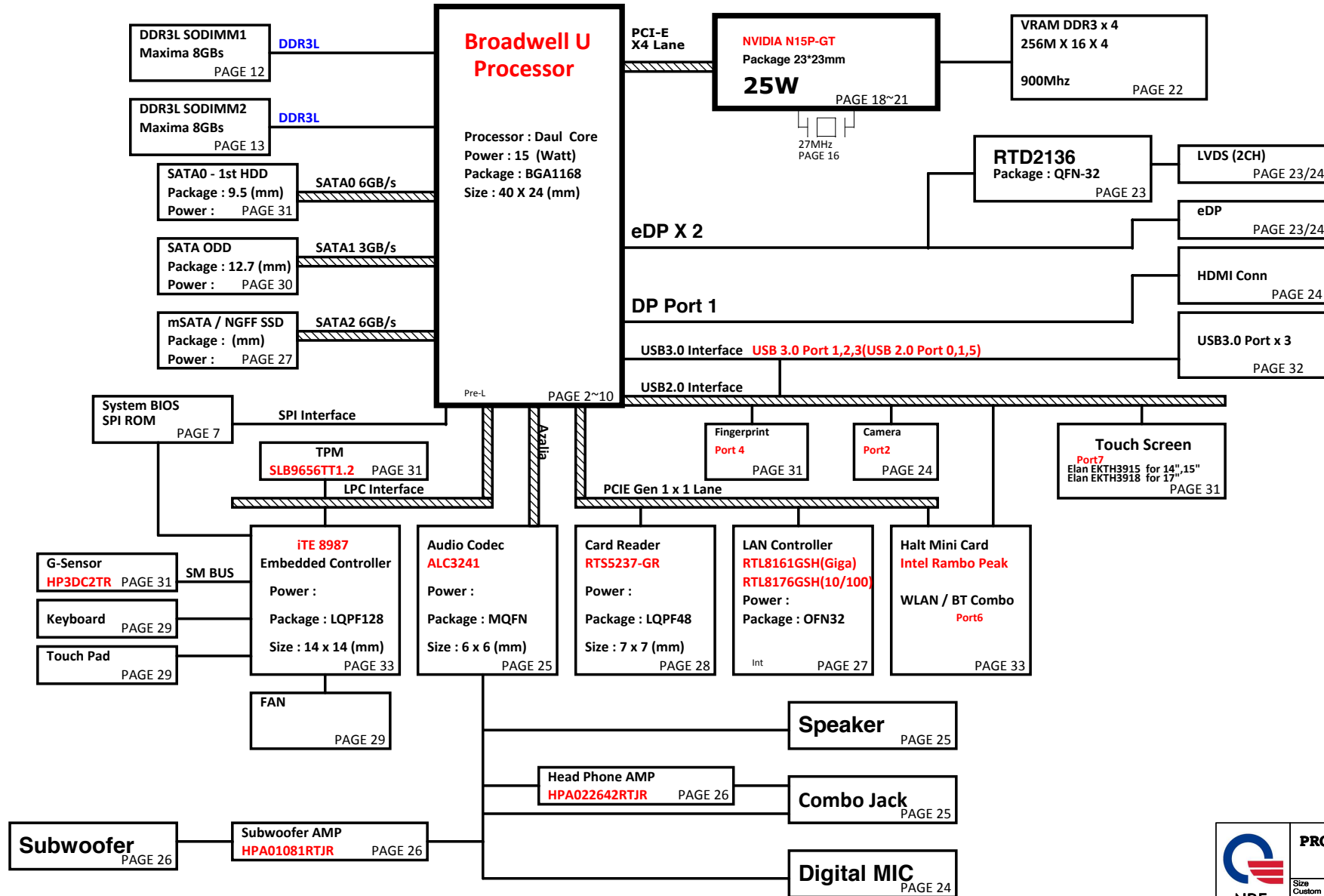

	<b>PROJECT : Y11C</b>	
	Quanta Computer Inc.	
	Size Custom	Document Number Block Diagram
Date: Tuesday, April 08, 2014   Sheet 1 of 44		

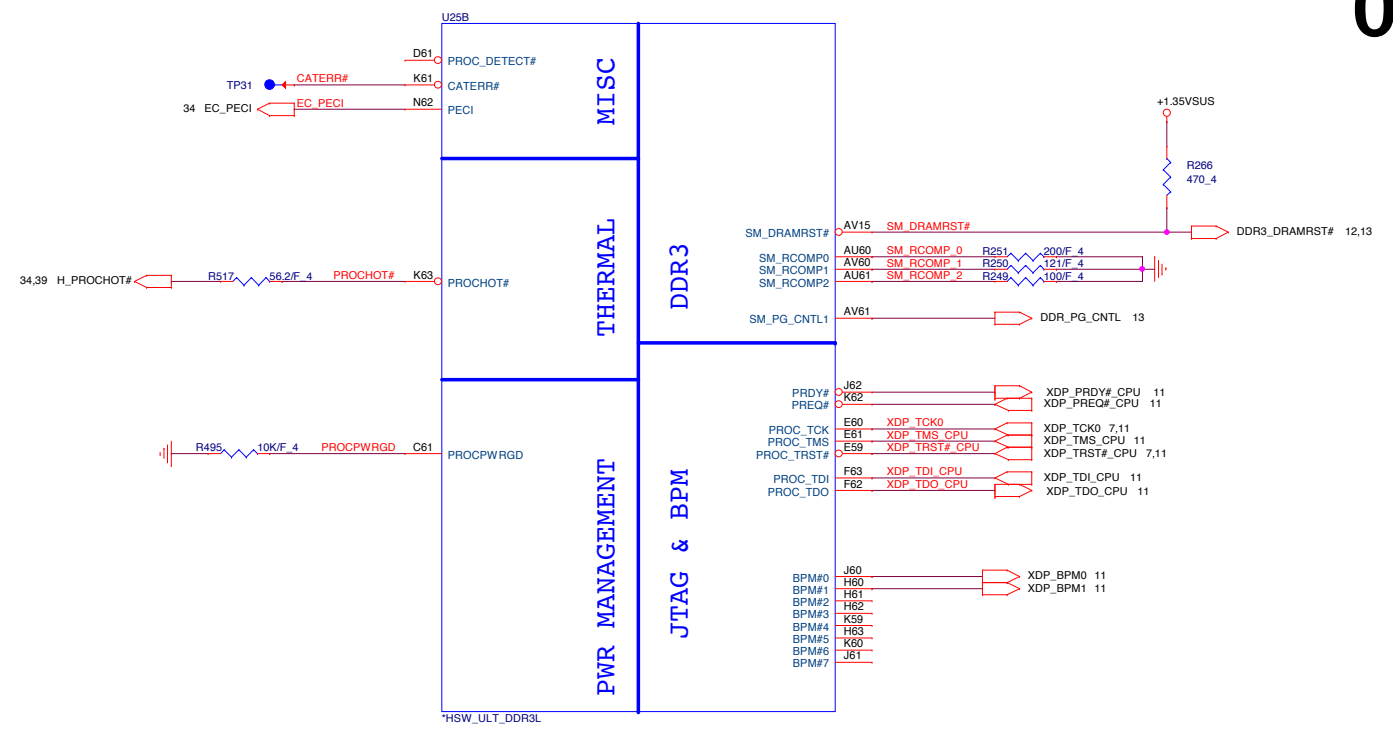
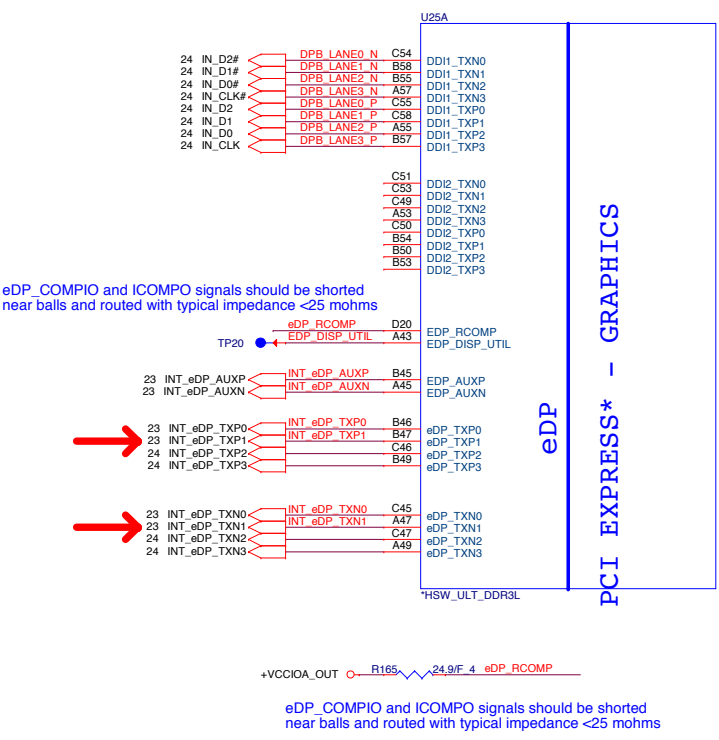

Processor pull-up (CPU)

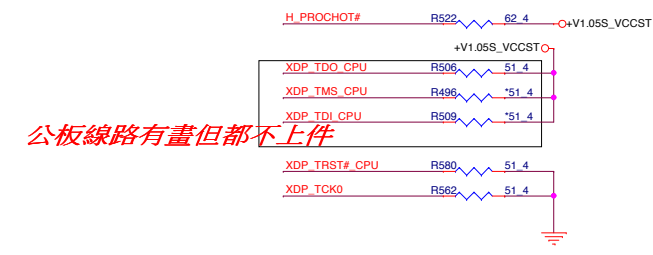

# Haswell ULT Processor (DDR3L)

- 12 M.A\_DQ[63:0]
- 13 M.B\_DQ[63:0]
- 12 M.A\_DQS[7:0]
- 12 M.A\_DQSP[7:0]
- 13 M.B\_DQS[7:0]
- 13 M.B\_DQSP[7:0]

U25C

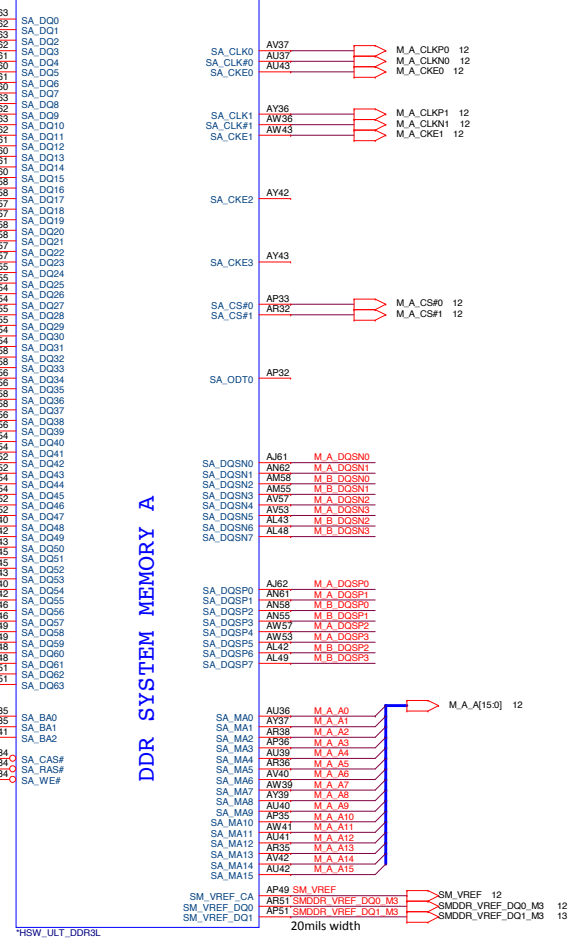

DDR SYSTEM MEMORY A

U25D

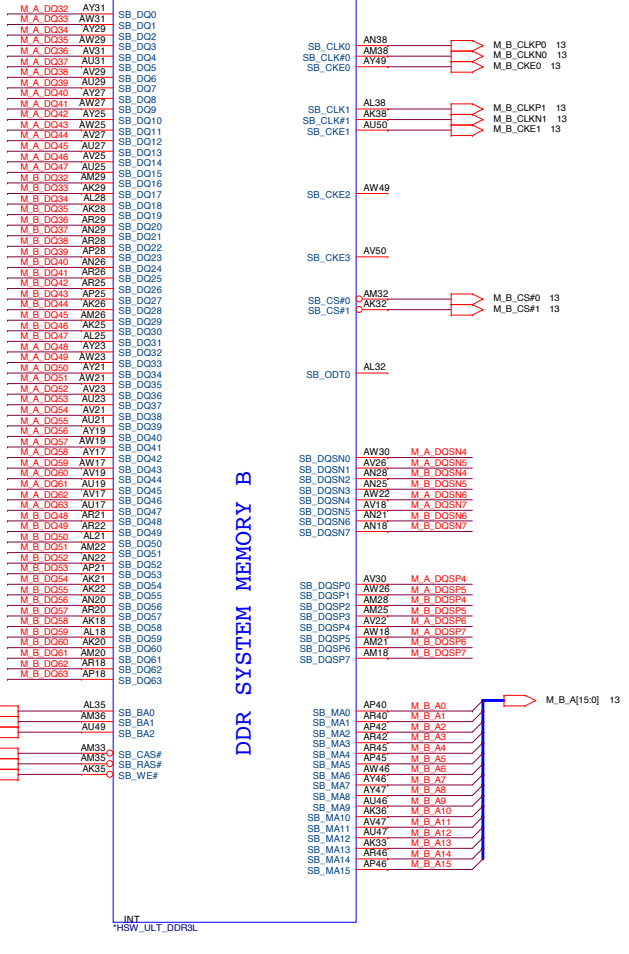

DDR SYSTEM MEMORY B

**PROJECT : Y11C**  
**Quanta Computer Inc.**

Size: Custom    Document Number: **ULT 2/9 (DDR3 I/F)**    Rev: 1A

Date: Wednesday, April 02, 2014    Sheet: 3 of 44



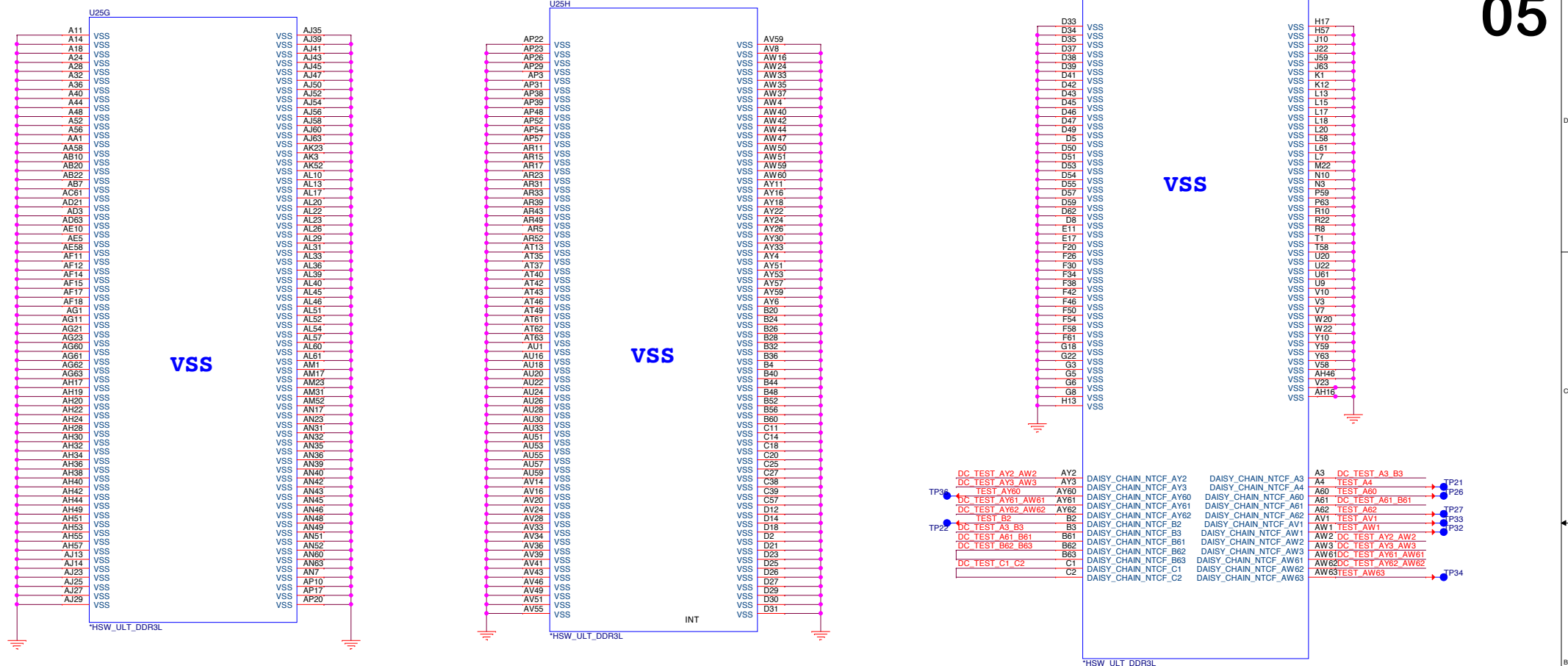

	<b>PROJECT : Y11C</b> <b>Quanta Computer Inc.</b>		Rev 1A
	Size Custom	Document Number <b>ULT 4/9 (RSV,GND)</b>	
Sheet 5 of 44		Date: <b>Wednesday, April 02, 2014</b>	

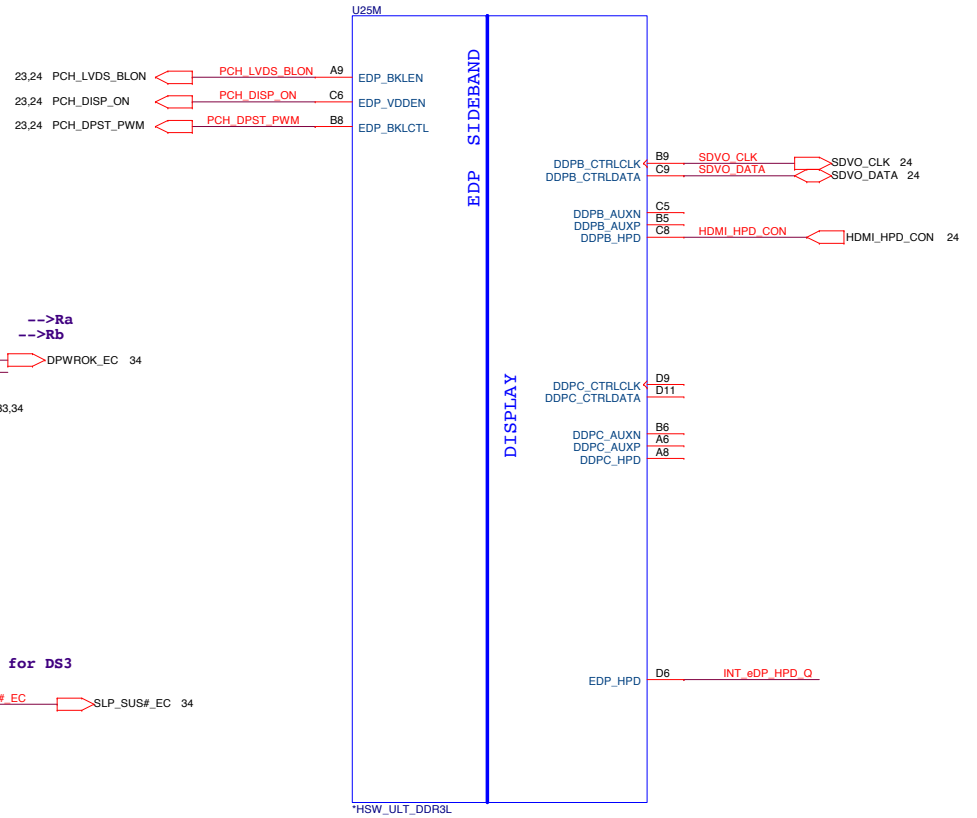

INT. HDMI

DISPLAY

EDP SIDEBAND

System Power Management

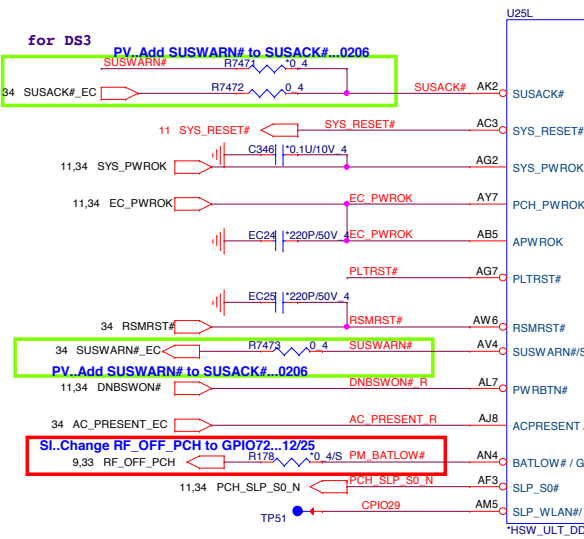

**PCH Pull-high/low(CLG)**

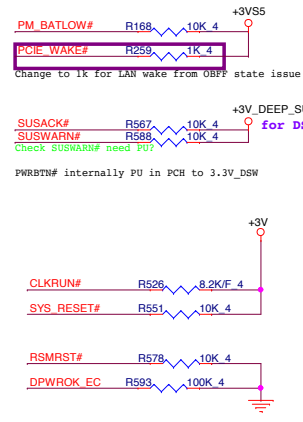

**PLTRST#(CLG)**

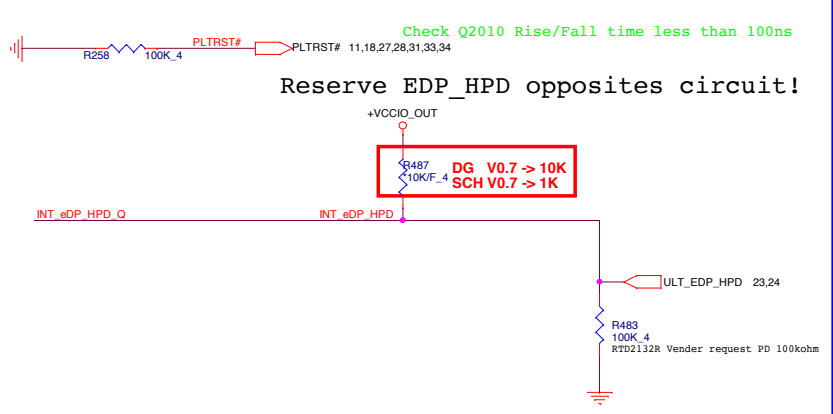

**System PWR\_OK(CLG)**

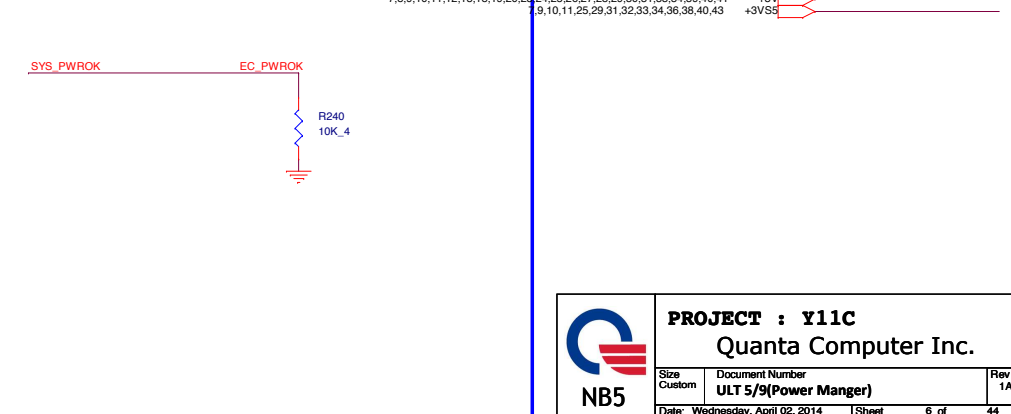

	<b>PROJECT : Y11C</b> Quanta Computer Inc.		Rev 1A
	Size Custom	Document Number ULT 5/9(Power Manger)	6 of 44
	Date: Wednesday, April 02, 2014 Sheet		

# Lynx Point-LP Platform Controller Hub (HDA, JTAG, SATA)

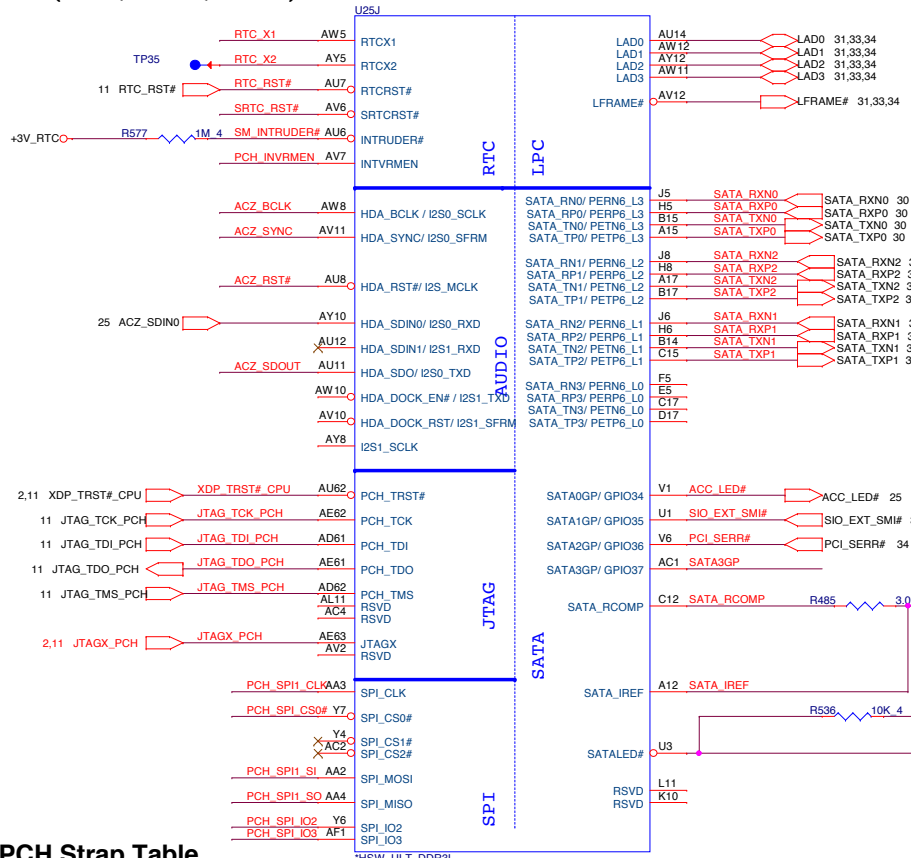

## PCH Strap Table

Pin Name	Strap description	Sampled	Configuration	Circuit								
SPKR	No reboot mode setting	PWROK	0 = Default (weak pull-down 20K) 1 = Setting to No-Reboot mode									
SDIO_D0/GPIO66	Top-Block Swap	PWROK	0 = "top-block swap" mode 1 = Default (weak pull-up 20K)									
INTVRMEN	Integrated 1.05V VRM enable	ALWAYS	Should be always pull-up	+3V_RTC - R575 330K 4 PCH_INVRMEN								
HDA_SDO/I2S0_TXD	Flash Descriptor Security Only for Interposer	PWROK	0 = Default (weak pull-down 20K) 1 = Can be Overriden	34 GPIO3_EC - R581 1K 4 ACZ_SDO								
GSPI0_MOSI/GPIO86	Boot BIOS Selection	PWROK	<table border="1"> <tr> <th>GNT0#</th> <th>Boot Location</th> </tr> <tr> <td>1</td> <td>LPC</td> </tr> <tr> <td>0</td> <td>SPI(Default)</td> </tr> </table>	GNT0#	Boot Location	1	LPC	0	SPI(Default)			
GNT0#	Boot Location											
1	LPC											
0	SPI(Default)											
GPIO15	TLS Confidentiality	PWROK	0 = ME Crypto Transport Layer Security cipher suite with no confidentiality(Default) 1 = Intel ME Crypto TLS cipher suite with confidentiality									
DSWVRMEN	Deep Sx Well On-Die Voltage Regulator Enable	ALWAYS	Should be always pull-up	+3V_RTC - R576 330K 4 DSWVRMEN 6								
				<table border="1"> <tr> <td>34 PCH_SPL_CS0# R</td> <td>PCH_SPL_CS0# R</td> </tr> <tr> <td>34 PCH_SPL_CLK# R</td> <td>PCH_SPL_CLK# R</td> </tr> <tr> <td>34 PCH_SPL_SI# R</td> <td>PCH_SPL_SI# R</td> </tr> <tr> <td>34 PCH_SPL_SO# R</td> <td>PCH_SPL_SO# R</td> </tr> </table>	34 PCH_SPL_CS0# R	PCH_SPL_CS0# R	34 PCH_SPL_CLK# R	PCH_SPL_CLK# R	34 PCH_SPL_SI# R	PCH_SPL_SI# R	34 PCH_SPL_SO# R	PCH_SPL_SO# R
34 PCH_SPL_CS0# R	PCH_SPL_CS0# R											
34 PCH_SPL_CLK# R	PCH_SPL_CLK# R											
34 PCH_SPL_SI# R	PCH_SPL_SI# R											
34 PCH_SPL_SO# R	PCH_SPL_SO# R											

HDD (SATA3 6.0Gb/s)  
 ODD (SATA2 3.0Gb/s)  
 mSATA / NGFF (SATA4 6Gb/s)

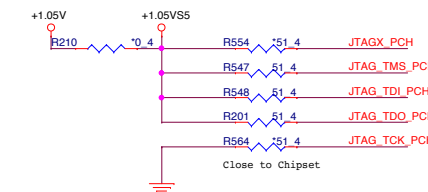

DG recommended that SATA AC coupling capacitors should be close to the connector (<100 mils) for optimal signal quality.

## RTC Clock 32.768KHz

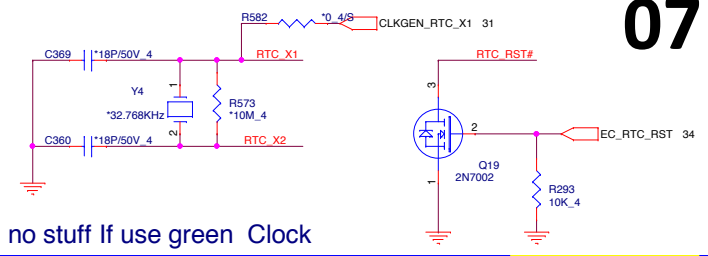

no stuff if use green Clock

## RTC Circuitry(RTC)

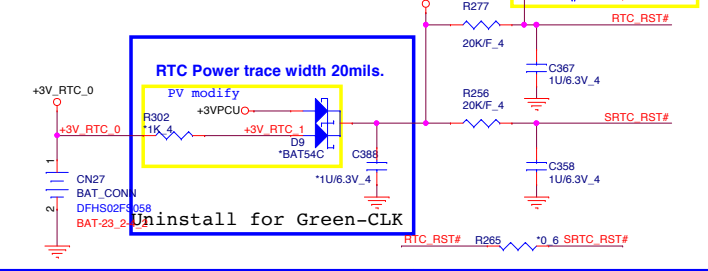

## HDA Bus(CLG)

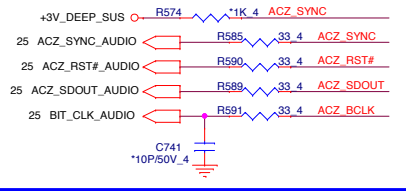

## GPIO Pull UP

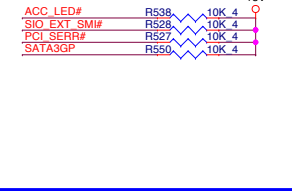

Vender	Size	P/N
MXIC	8MB	AKE3EZN0Z00 (MX25L6473EM2I-10G)
Winbond	8MB	AKE3EFP0N07 (W25Q64FVSSIQ)
GigaDevice	8MB	AKE3EGN0Q01 (GD25B64BSIGR)
Socket		DFHS08FS023

## 4M SPI ROM Socket

U10&U15 footprint 要重叠

## PCH SPI ROM(CLG)

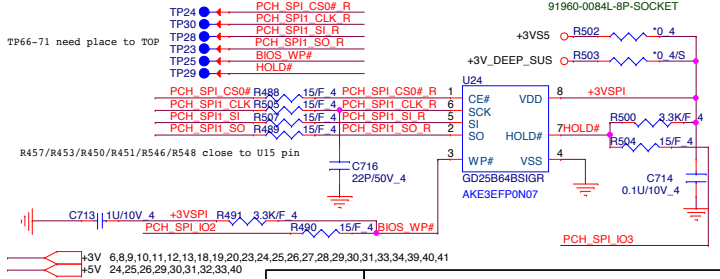

+3V 6,8,9,10,11,12,13,16,19,20,23,24,25,26,27,28,29,30,31,33,34,39,40,41  
 +5V 24,25,26,29,30,31,32,33,40

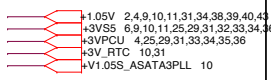

**PROJECT : Y11C**  
**Quanta Computer Inc.**

Size Custom	Document Number ULT 6/9(SATA/HDA)	Rev 1A
Date: Wednesday, April 02, 2014	Sheet 7 of	44

# Lynx Point-LP Platform Controller Hub (HDA, JTAG, SATA)

## PCI/USBOC# Pull-up(CLG)

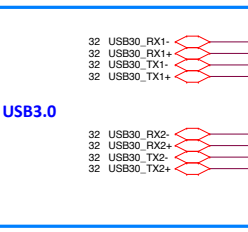
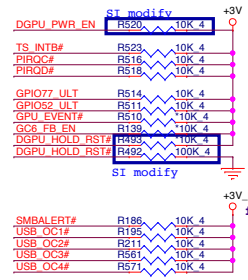

20111130 Modify USB3.0 for HM70

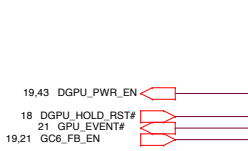

## SMBus/Pull-up(CLG)

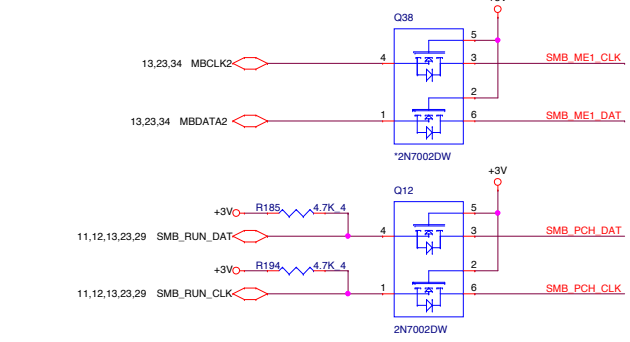

## CLK\_REQ/Strap Pin(CLG)

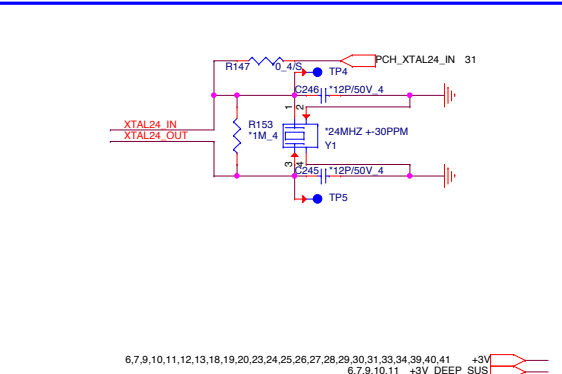
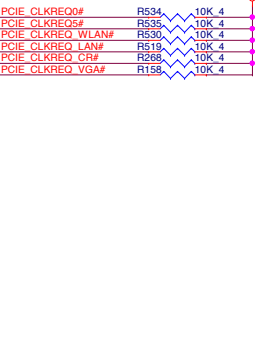

## SMBus/Pull-up(CLG)

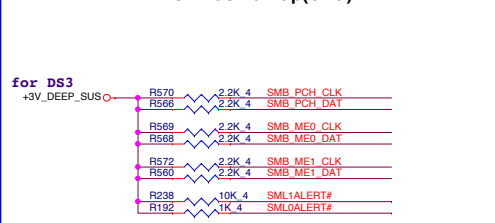

**PROJECT : Y11C**  
**Quanta Computer Inc.**

Size Custom Document Number **ULT 7/9 (PCIE/USB/CLK)** Rev 1A

Date: Wednesday, April 02, 2014 Sheet 8 of 44

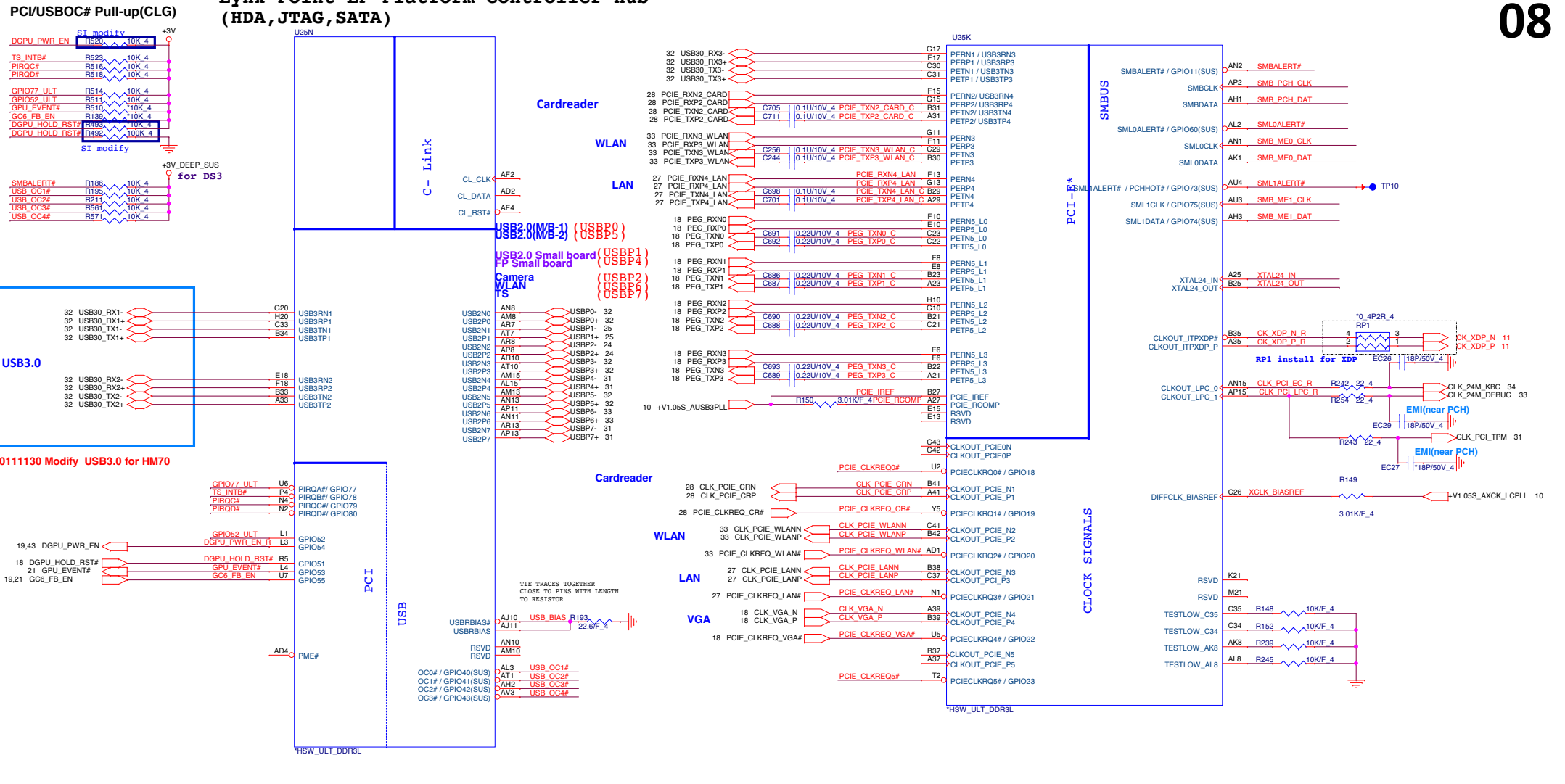



# Lynx Point-LP Platform Controller Hub (HDA,JTAG,SATA) Haswell (GPIO)

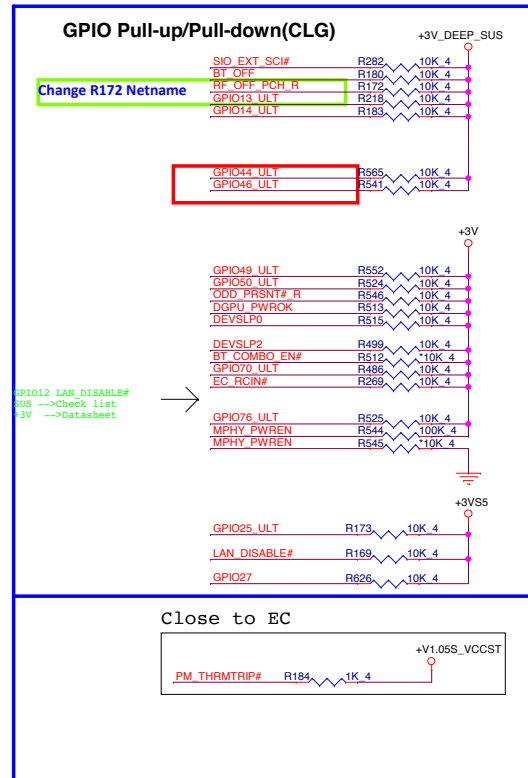
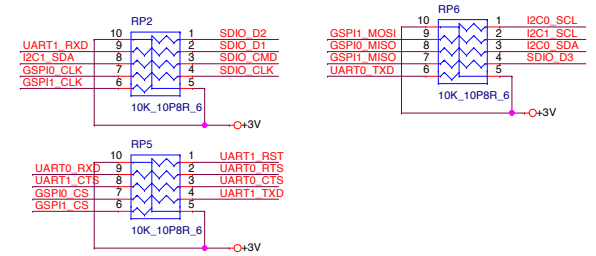
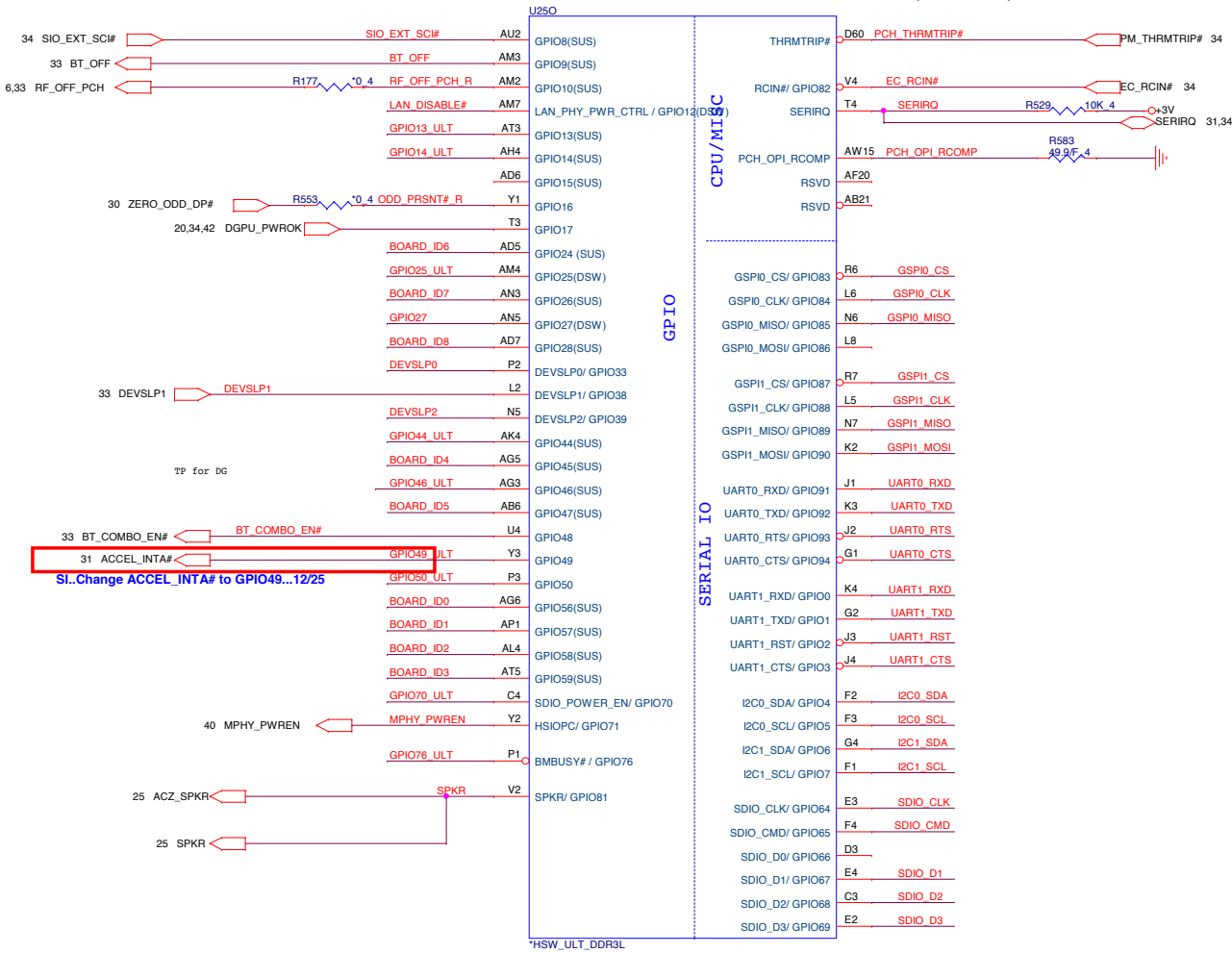

Model	BOARD_ID[6-5] Reserve	BOARD_ID4 Reserve	BOARD_ID3 Pavillian	BOARD_ID[2-1] 00 14" 01 15" 10 17"	BOARD_ID0 0 : UMA 1 : DIS

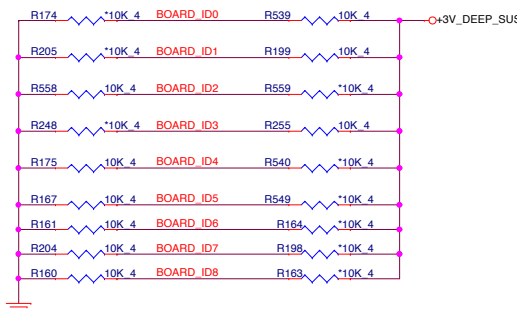

	DIS	UMA
Stuff	Ra	Rb
NC	Rb	Ra

6,7,8,10,11,12,13,18,19,20,23,24,25,26,27,28,29,30,31,33,34,39,40,41  
6,7,10,11,25,29,31,32,33,34,36,38,40,43

**PROJECT : Y11C**  
**Quanta Computer Inc.**

Size Custom Document Number **ULT 8/9 (GPIO/MISC)** Rev 1A

Date: Wednesday, April 02, 2014 Sheet 9 of 44

NB5

# Lynx Point-LP Platform Controller Hub (HDA, JTAG, SATA) (POWER)

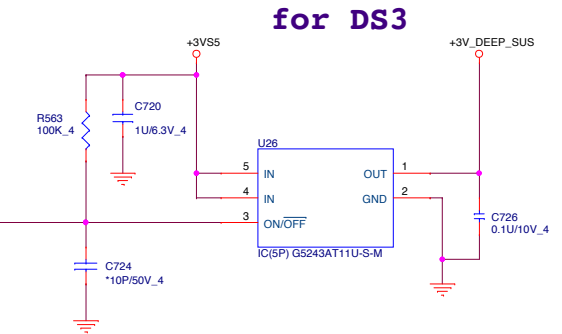
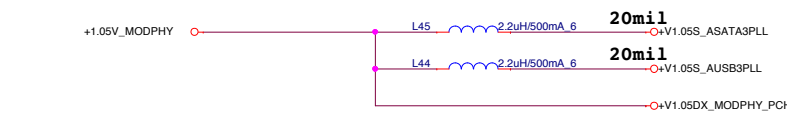
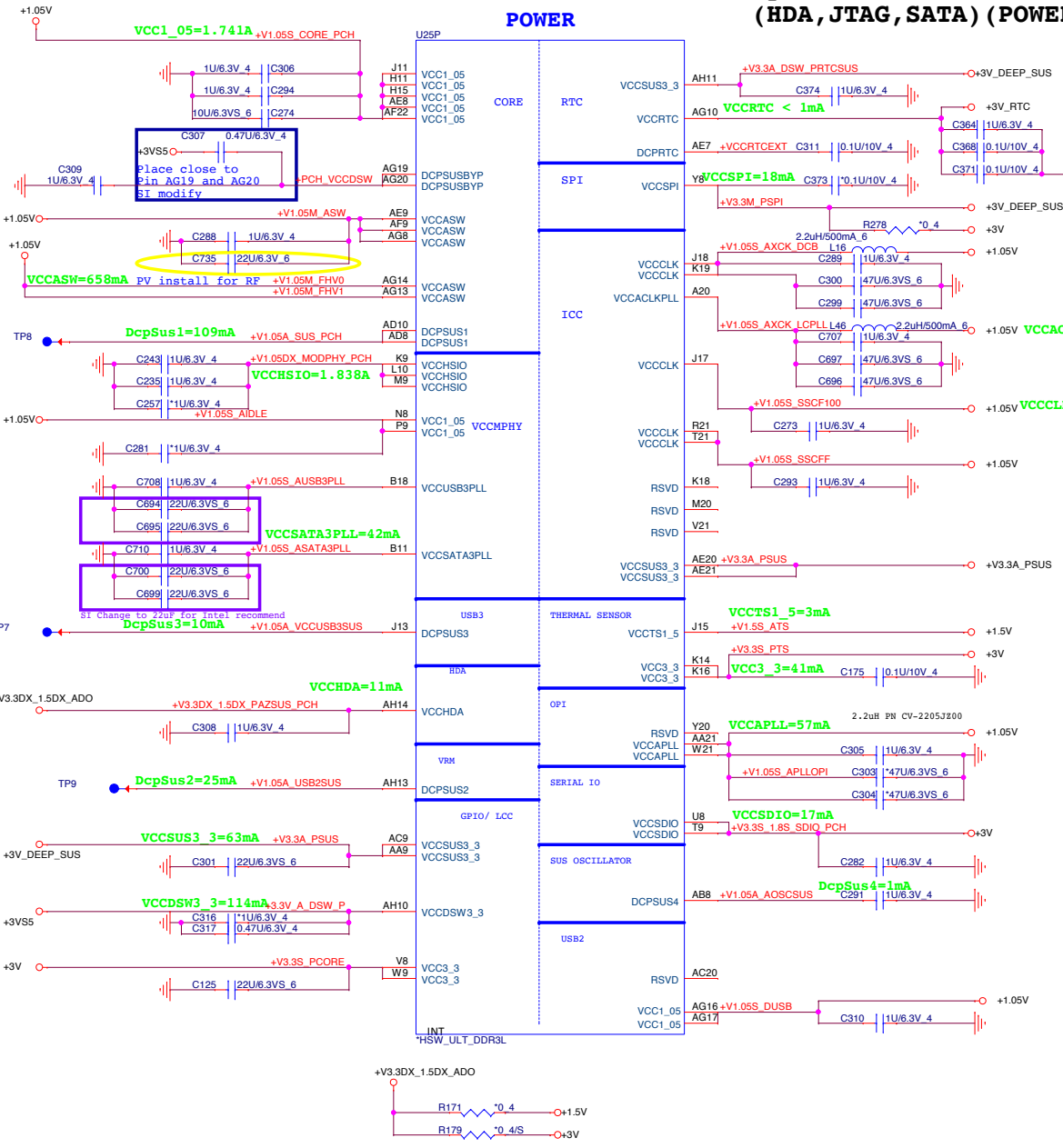

for DS3

6,7,8,9,11,12,13,18,19,20,23,24,25,26,27,28,29,30,31,33,34,39,40,41	+3V	8	+V1.05S_AUSB3PLL
24,25,26,29,30,31,32,33,40	+5V	7	+V1.05S_ASATA3PLL
2,4,7,9,11,31,34,38,39,40,43	+1.05V	8	+V1.05S_AXCK_LCPLL
6,7,9,11,25,29,31,32,33,34,36,38,40,43	+3VS5	7,31	+3V_RTC
13,25,29,32,36,37,38,39,40,41,42,43	+5VS5	2,4,12,13,29,37	+1.35VSUS

**PROJECT : Y11C**  
**Quanta Computer Inc.**

Size Custom	Document Number	Rev 1A
	<b>ULT 9/9(Power-2)</b>	
Date: Tuesday, April 08, 2014	Sheet 10 of	44

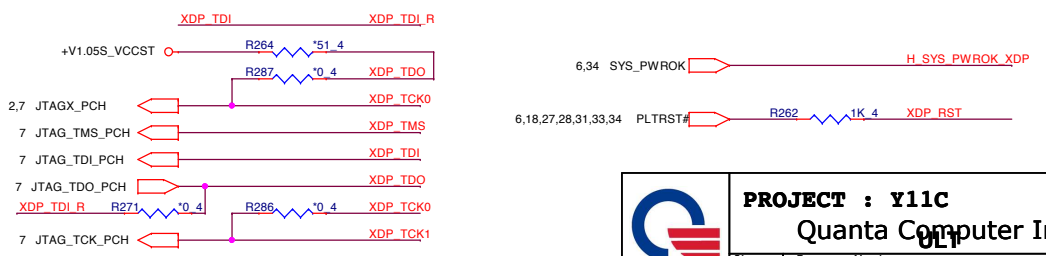
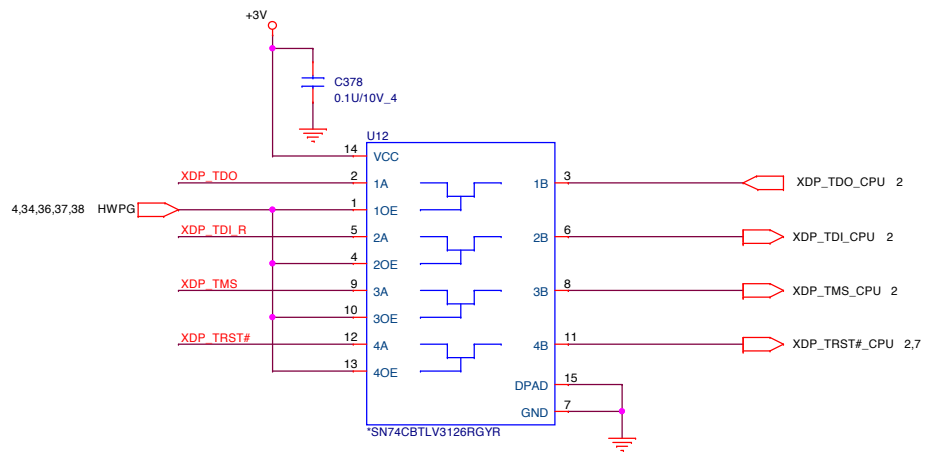
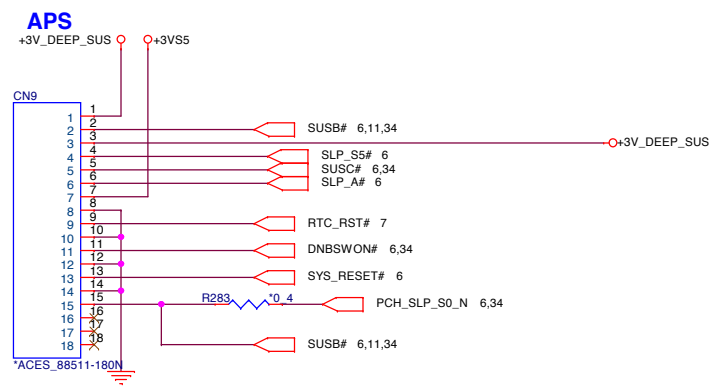
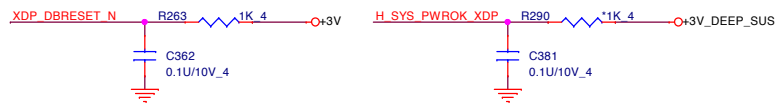
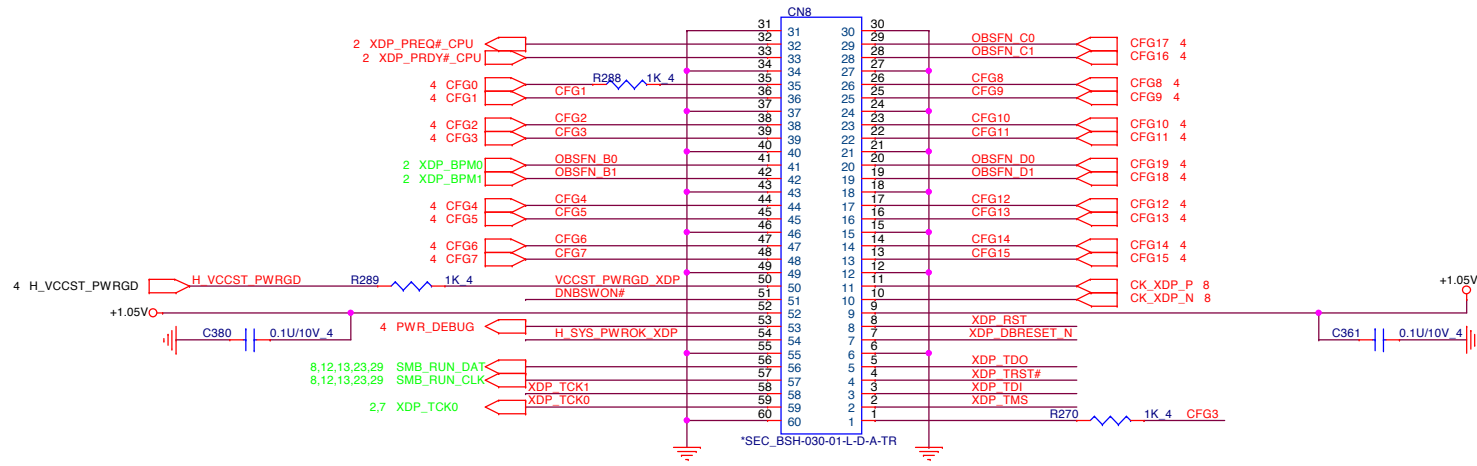

	<b>PROJECT : Y11C</b>		Rev 1A
	<b>Quanta Computer Inc.</b>		
	Size <b>HSW XDP &amp; APS</b>	Document Number <b>HSW XDP &amp; APS</b>	
Date: Wednesday, April 02, 2014		Sheet 11 of 44	

**DIMM & Footprint 同Joshua提供**

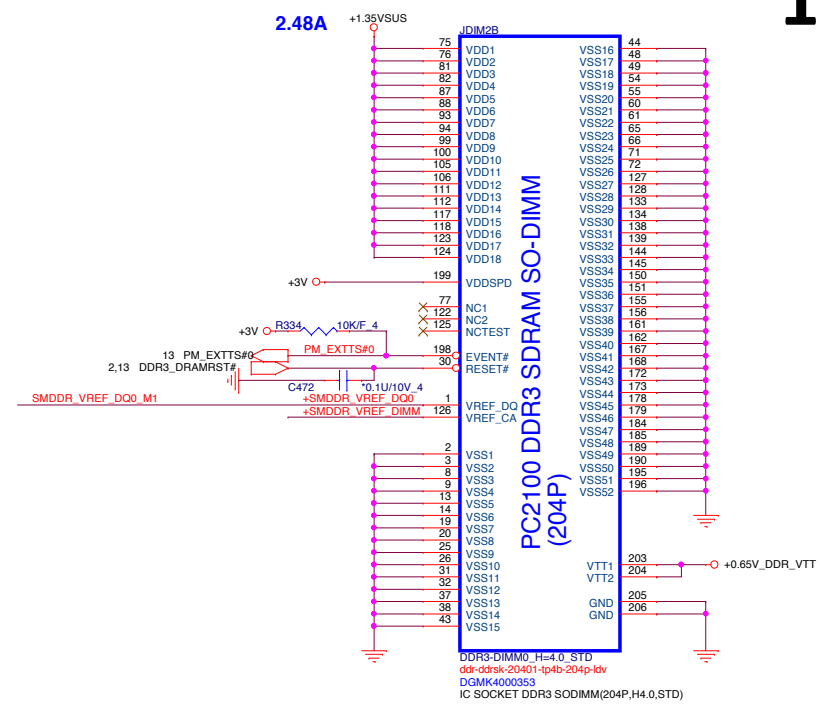
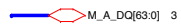
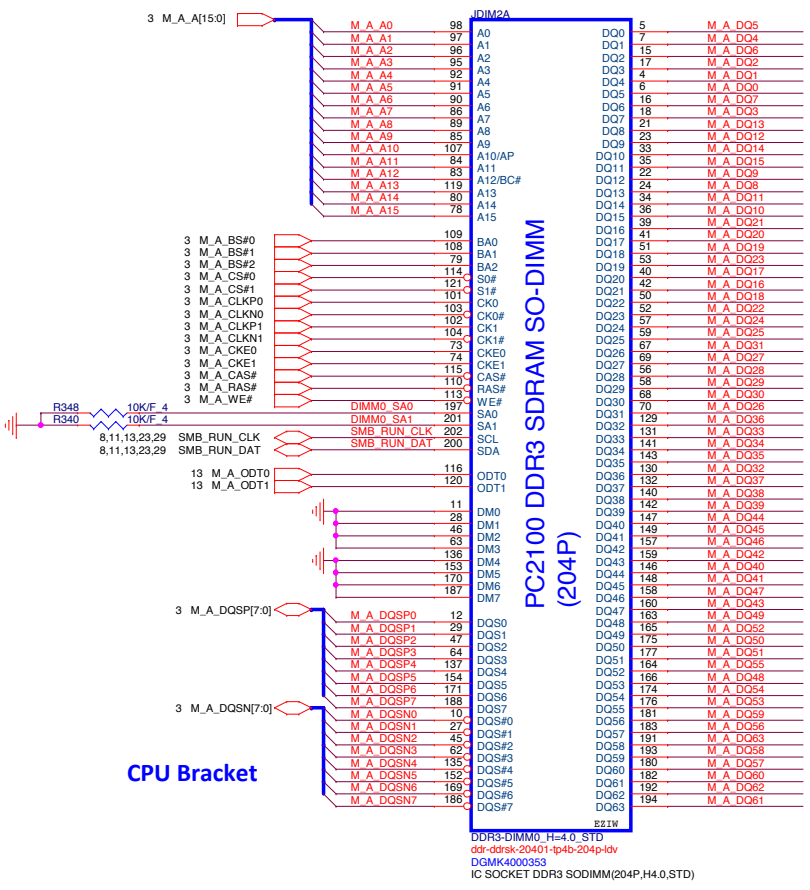

**CPU Bracket**

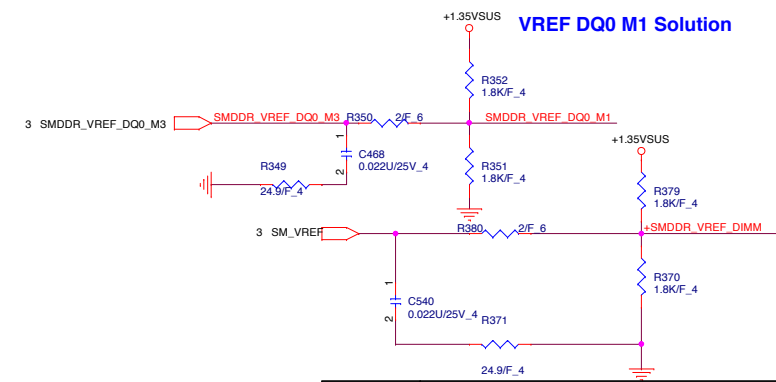
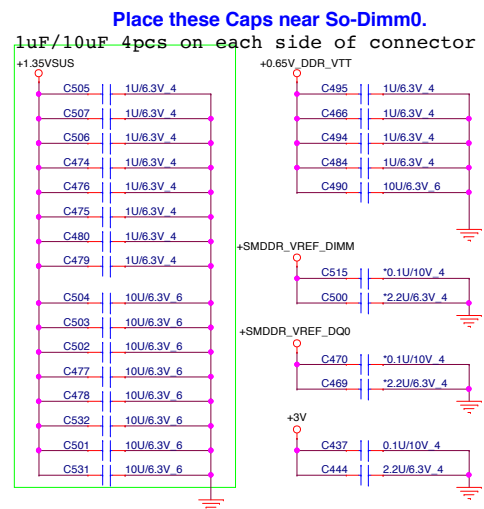
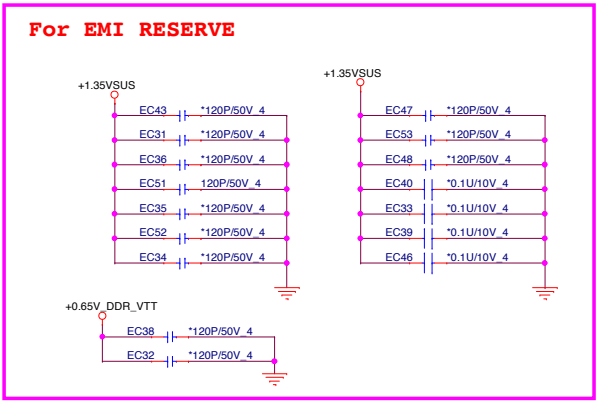

**PROJECT : Y11C**  
**Quanta Computer Inc.**

**NB5**

Size	Document Number	Rev
Custom	DDR3 DIMM0-STD(4.0H)	1A
Date: Wednesday, April 02, 2014	Sheet	12 of 44

DIMM & Footprint 同Joshua提供

M\_B\_DQ[63:0] 3

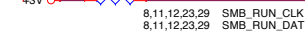
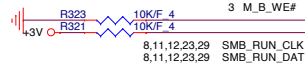
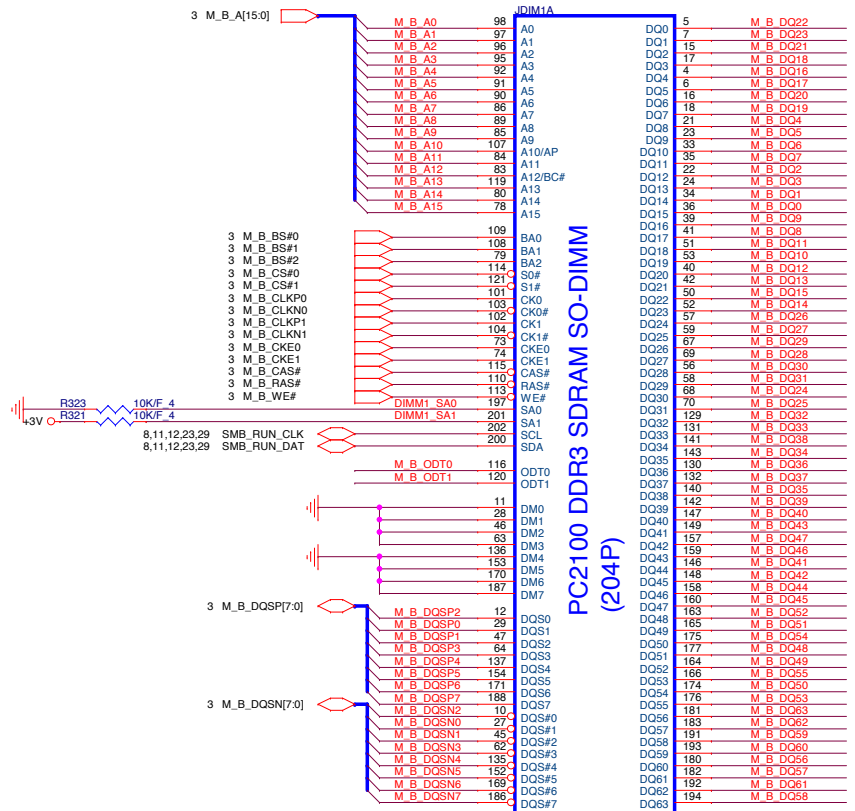

DDR3-DIMM1\_H=4.0\_RVS  
 ddr-ddr3k-20401-tp4b-204p-ruv  
 DGMK4000264

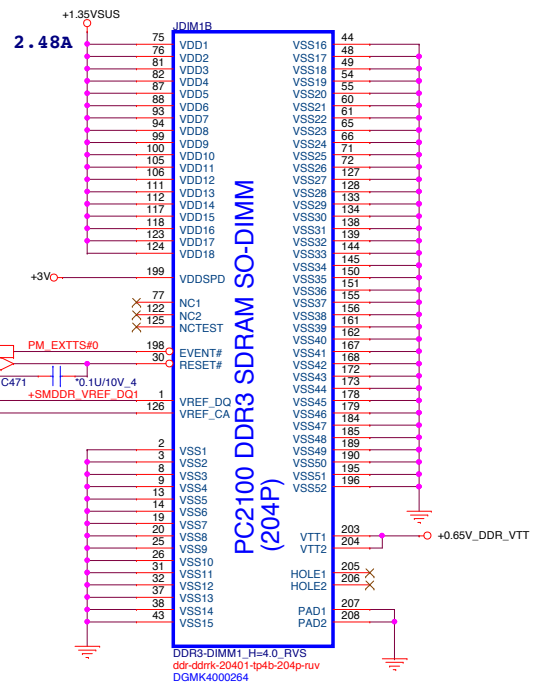

PC2100 DDR3 SDRAM SO-DIMM (204P)

DDR3-DIMM1\_H=4.0\_RVS  
 ddr-ddr3k-20401-tp4b-204p-ruv  
 DGMK4000264

Local Thermal Sensor

mv可移除

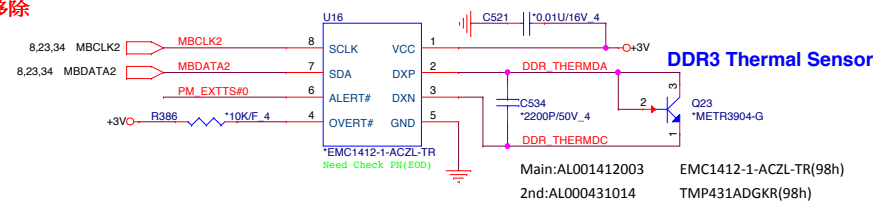

Main:AL001412003 EMC1412-1-ACZL-TR(98h)  
 2nd:AL000431014 TMP431ADGKR(98h)

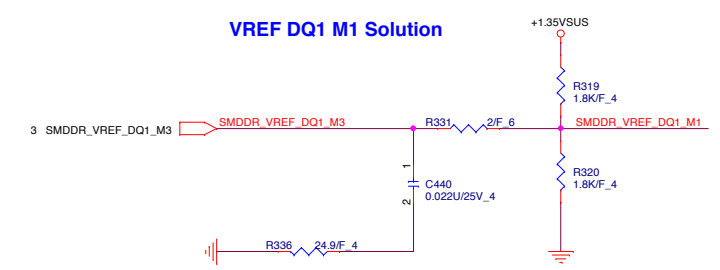
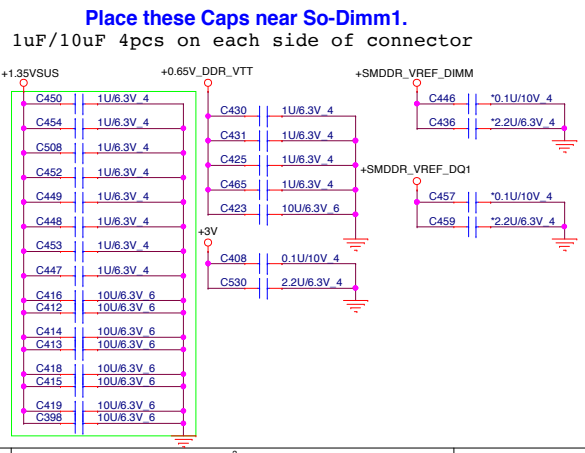
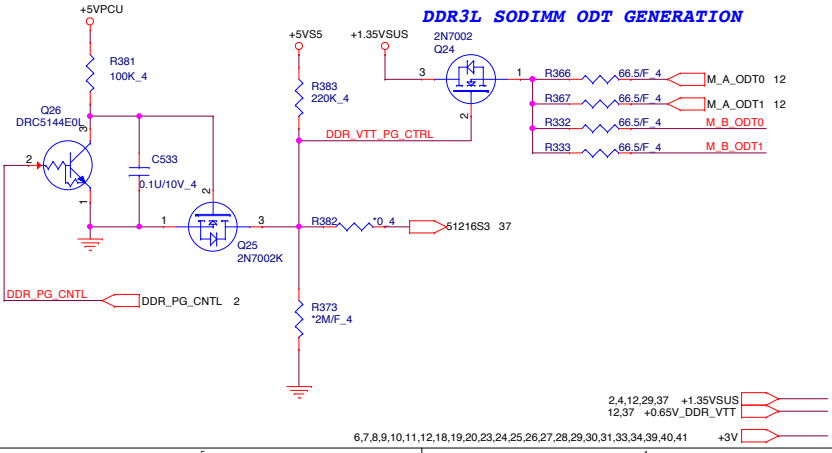

**PROJECT : Y11C**  
**Quanta Computer Inc.**

NB5

Size Custom	Document Number	Rev 1A
	<b>DDR3 DIMM1-RV5(4.0H)</b>	
Date: Wednesday, April 02, 2014	Sheet	13 of 44

	<b>PROJECT :Y05</b>	
	Quanta Computer Inc.	
	Size Custom	Document Number <b>N15S-GT (PCIE VF) /NVDD</b>
Date: Wednesday, April 02, 2014		
Sheet 14 of 44		

	<b>PROJECT :Y05</b> Quanta Computer Inc.		
	Size Custom	Document Number <b>N15S-GT (MEMORY/GND)</b>	Rev 2A
	Date: Wednesday, April 02, 2014		Sheet 15 of 44



**PROJECT :Y05**  
Quanta Computer Inc.

Size Custom	Document Number <b>N15S-GT (DISPLAY)</b>	Rev 2A
Date: Wednesday, April 02, 2014		Sheet 16 of 44



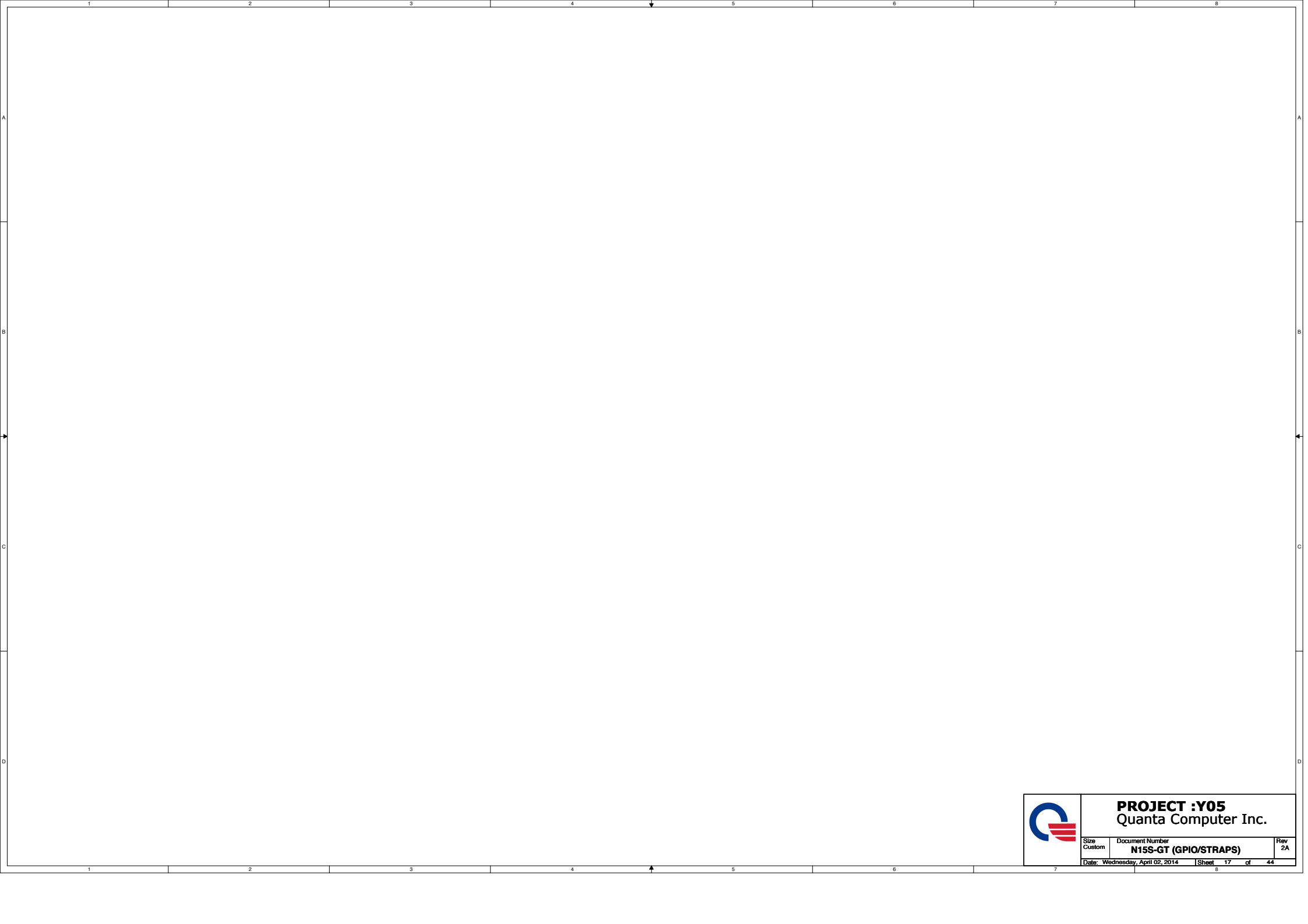

**PROJECT :Y05**  
Quanta Computer Inc.

Size Custom	Document Number <b>N15S-GT (GPIO/STRAPS)</b>	Rev 2A
----------------	---	-----------

Date: Wednesday, April 02, 2014 Sheet 17 of 44

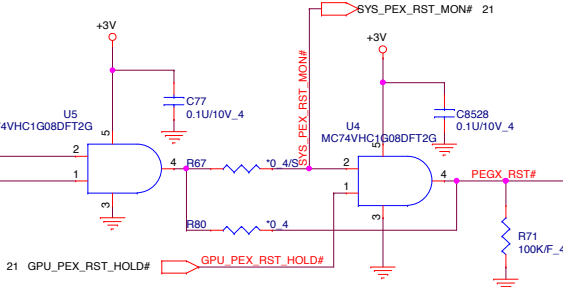
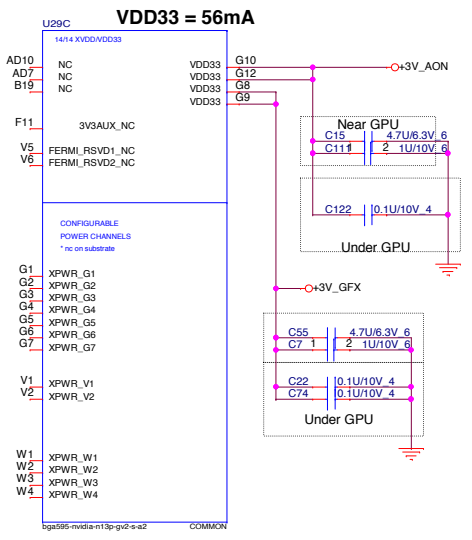
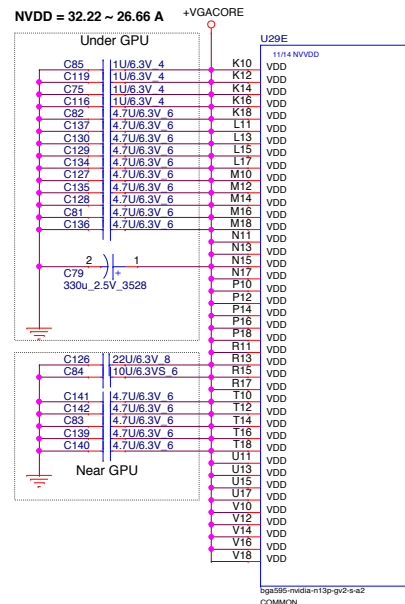
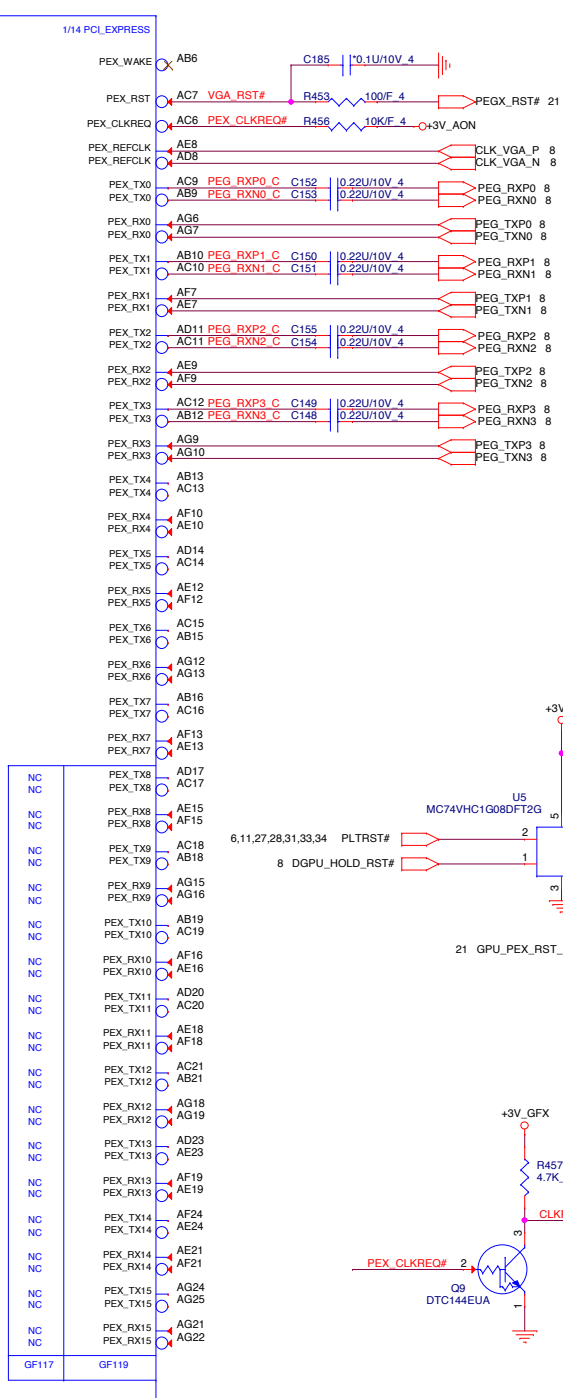
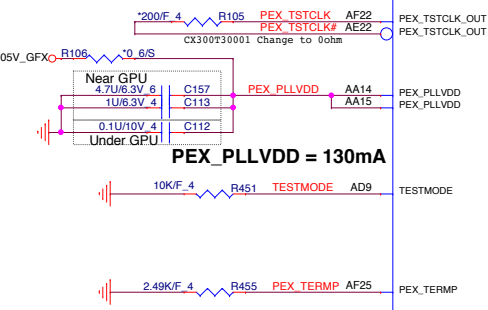
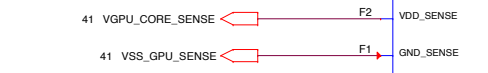
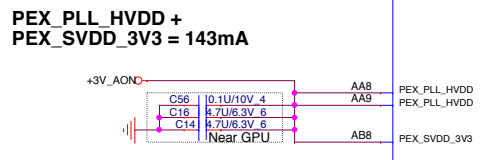
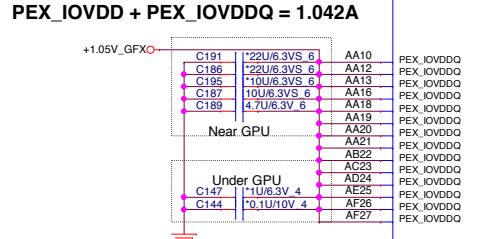
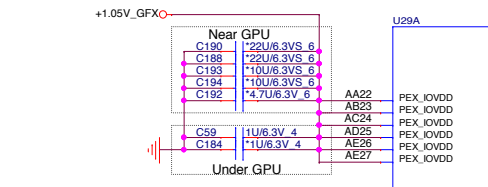

**Power up sequence**

VDD33  
+3.3V\_GFX  
NVDD  
+VCC\_DGFX\_CORE  
FBVDDQ  
+1.5V\_GFX  
PEX\_VDD  
+1.05V\_GFX  
IFP(CDEF)\_IOVDD  
+1.05V\_GFX

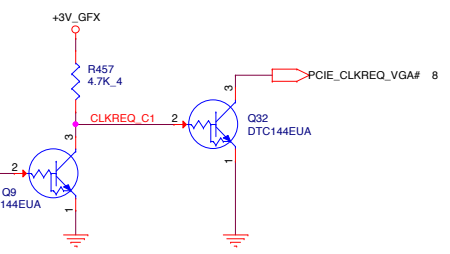
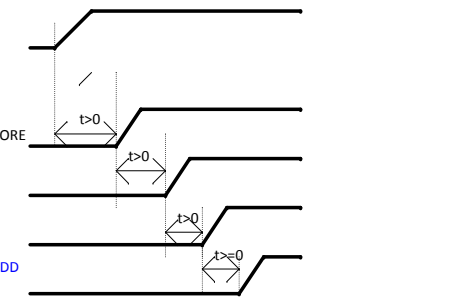

**Power down sequence**

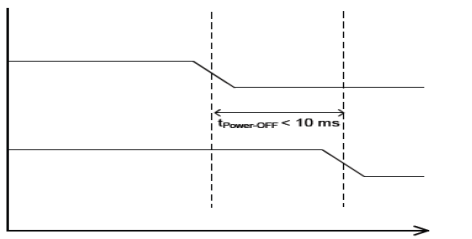

**PROJECT :U82**  
Quanta Computer Inc.

Size Custom	Document Number <b>N14M-GS (PCIE VF) /NVDD</b>	Rev 2A
Date: Wednesday, April 02, 2014	Sheet 18 of 44	

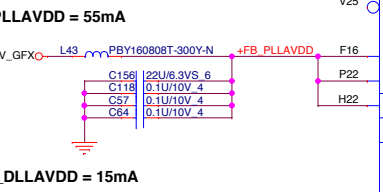
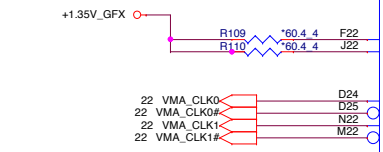
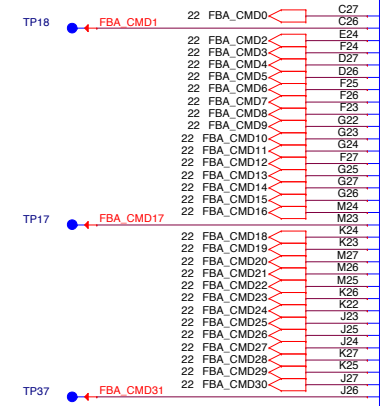
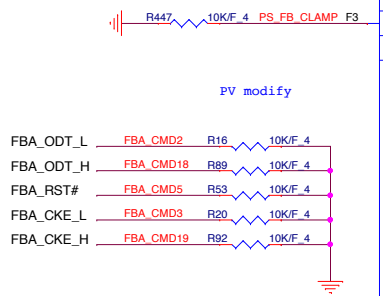

NC	GF119
FB_CLAMP	GF117
FBA_CMD0	C27
FBA_CMD1	E24
FBA_CMD2	F24
FBA_CMD3	D27
FBA_CMD4	F26
FBA_CMD5	F25
FBA_CMD6	F26
FBA_CMD7	F23
FBA_CMD8	G22
FBA_CMD9	G23
FBA_CMD10	G24
FBA_CMD11	G24
FBA_CMD12	F27
FBA_CMD13	G26
FBA_CMD14	G27
FBA_CMD15	G26
FBA_CMD16	M24
FBA_CMD17	M23
FBA_CMD18	K24
FBA_CMD19	K23
FBA_CMD20	M27
FBA_CMD21	M26
FBA_CMD22	M25
FBA_CMD23	K26
FBA_CMD24	K22
FBA_CMD25	J23
FBA_CMD26	J25
FBA_CMD27	J24
FBA_CMD28	K27
FBA_CMD29	K25
FBA_CMD30	J27
FBA_CMD31	J26
FBA_CMD0	C27
FBA_CMD1	E24
FBA_CMD2	F24
FBA_CMD3	D27
FBA_CMD4	F26
FBA_CMD5	F25
FBA_CMD6	F26
FBA_CMD7	F23
FBA_CMD8	G22
FBA_CMD9	G23
FBA_CMD10	G24
FBA_CMD11	G24
FBA_CMD12	F27
FBA_CMD13	G26
FBA_CMD14	G27
FBA_CMD15	G26
FBA_CMD16	M24
FBA_CMD17	M23
FBA_CMD18	K24
FBA_CMD19	K23
FBA_CMD20	M27
FBA_CMD21	M26
FBA_CMD22	M25
FBA_CMD23	K26
FBA_CMD24	K22
FBA_CMD25	J23
FBA_CMD26	J25
FBA_CMD27	J24
FBA_CMD28	K27
FBA_CMD29	K25
FBA_CMD30	J27
FBA_CMD31	J26
FBA_DEBUG0	F22
FBA_DEBUG1	J22
FBA_CLK0	D24
FBA_CLK0	D25
FBA_CLK1	N22
FBA_CLK1	M22
FBA_WCK0	D18
FBA_WCK0	C18
FBA_WCK23	D17
FBA_WCK23	D16
FBA_WCK45	T24
FBA_WCK45	U24
FBA_WCK45	V24
FBA_WCK67	V25
FBA_WCK67	V25
FBA_DEBUG0	F22
FBA_DEBUG1	J22
FBA_CLK0	D24
FBA_CLK0	D25
FBA_CLK1	N22
FBA_CLK1	M22
FBA_WCK0	D18
FBA_WCK0	C18
FBA_WCK23	D17
FBA_WCK23	D16
FBA_WCK45	T24
FBA_WCK45	U24
FBA_WCK45	V24
FBA_WCK67	V25
FBA_WCK67	V25

FBA_D0	E18	VMA_DQ0
FBA_D1	F18	VMA_DQ1
FBA_D2	E16	VMA_DQ2
FBA_D3	F17	VMA_DQ3
FBA_D4	D20	VMA_DQ4
FBA_D5	D21	VMA_DQ5
FBA_D6	E21	VMA_DQ6
FBA_D7	E21	VMA_DQ7
FBA_D8	E15	VMA_DQ8
FBA_D9	D15	VMA_DQ9
FBA_D10	F15	VMA_DQ10
FBA_D11	F13	VMA_DQ11
FBA_D12	C13	VMA_DQ12
FBA_D13	B13	VMA_DQ13
FBA_D14	E13	VMA_DQ14
FBA_D15	C14	VMA_DQ15
FBA_D16	B15	VMA_DQ16
FBA_D17	C16	VMA_DQ17
FBA_D18	A13	VMA_DQ18
FBA_D19	A15	VMA_DQ19
FBA_D20	B18	VMA_DQ20
FBA_D21	A18	VMA_DQ21
FBA_D22	A19	VMA_DQ22
FBA_D23	C19	VMA_DQ23
FBA_D24	B24	VMA_DQ24
FBA_D25	C23	VMA_DQ25
FBA_D26	A25	VMA_DQ26
FBA_D27	A24	VMA_DQ27
FBA_D28	A21	VMA_DQ28
FBA_D29	B21	VMA_DQ29
FBA_D30	C20	VMA_DQ30
FBA_D31	C21	VMA_DQ31
FBA_D32	R22	VMA_DQ32
FBA_D33	R24	VMA_DQ33
FBA_D34	T22	VMA_DQ34
FBA_D35	R23	VMA_DQ35
FBA_D36	N25	VMA_DQ36
FBA_D37	N26	VMA_DQ37
FBA_D38	N23	VMA_DQ38
FBA_D39	N24	VMA_DQ39
FBA_D40	V23	VMA_DQ40
FBA_D41	V22	VMA_DQ41
FBA_D42	T23	VMA_DQ42
FBA_D43	U22	VMA_DQ43
FBA_D44	Y24	VMA_DQ44
FBA_D45	AA24	VMA_DQ45
FBA_D46	Y22	VMA_DQ46
FBA_D47	AA23	VMA_DQ47
FBA_D48	AD27	VMA_DQ48
FBA_D49	AB25	VMA_DQ49
FBA_D50	AD26	VMA_DQ50
FBA_D51	AC25	VMA_DQ51
FBA_D52	AA27	VMA_DQ52
FBA_D53	AA26	VMA_DQ53
FBA_D54	W26	VMA_DQ54
FBA_D55	Y25	VMA_DQ55
FBA_D56	R26	VMA_DQ56
FBA_D57	T25	VMA_DQ57
FBA_D58	N27	VMA_DQ58
FBA_D59	R27	VMA_DQ59
FBA_D60	V26	VMA_DQ60
FBA_D61	V27	VMA_DQ61
FBA_D62	W27	VMA_DQ62
FBA_D63	W25	VMA_DQ63
FBA_DQM0	D19	VMA_DM0
FBA_DQM1	D14	VMA_DM1
FBA_DQM2	C17	VMA_DM2
FBA_DQM3	C22	VMA_DM3
FBA_DQM4	P24	VMA_DM4
FBA_DQM5	W24	VMA_DM5
FBA_DQM6	AA25	VMA_DM6
FBA_DQM7	U25	VMA_DM7
FBA_DQS_WP0	E19	VMA_WDQS0
FBA_DQS_WP1	C15	VMA_WDQS1
FBA_DQS_WP2	B16	VMA_WDQS2
FBA_DQS_WP3	B22	VMA_WDQS3
FBA_DQS_WP4	R25	VMA_WDQS4
FBA_DQS_WP5	W23	VMA_WDQS5
FBA_DQS_WP6	AB28	VMA_WDQS6
FBA_DQS_WP7	T26	VMA_WDQS7
FBA_DQS_RN0	F19	VMA_RDQS0
FBA_DQS_RN1	C14	VMA_RDQS1
FBA_DQS_RN2	A16	VMA_RDQS2
FBA_DQS_RN3	A22	VMA_RDQS3
FBA_DQS_RN4	P25	VMA_RDQS4
FBA_DQS_RN5	W22	VMA_RDQS5
FBA_DQS_RN6	AB27	VMA_RDQS6
FBA_DQS_RN7	T27	VMA_RDQS7
FBA_DQM0	D19	VMA_DM0
FBA_DQM1	D14	VMA_DM1
FBA_DQM2	C17	VMA_DM2
FBA_DQM3	C22	VMA_DM3
FBA_DQM4	P24	VMA_DM4
FBA_DQM5	W24	VMA_DM5
FBA_DQM6	AA25	VMA_DM6
FBA_DQM7	U25	VMA_DM7
FBA_DQS_WP0	E19	VMA_WDQS0
FBA_DQS_WP1	C15	VMA_WDQS1
FBA_DQS_WP2	B16	VMA_WDQS2
FBA_DQS_WP3	B22	VMA_WDQS3
FBA_DQS_WP4	R25	VMA_WDQS4
FBA_DQS_WP5	W23	VMA_WDQS5
FBA_DQS_WP6	AB28	VMA_WDQS6
FBA_DQS_WP7	T26	VMA_WDQS7
FBA_DQS_RN0	F19	VMA_RDQS0
FBA_DQS_RN1	C14	VMA_RDQS1
FBA_DQS_RN2	A16	VMA_RDQS2
FBA_DQS_RN3	A22	VMA_RDQS3
FBA_DQS_RN4	P25	VMA_RDQS4
FBA_DQS_RN5	W22	VMA_RDQS5
FBA_DQS_RN6	AB27	VMA_RDQS6
FBA_DQS_RN7	T27	VMA_RDQS7

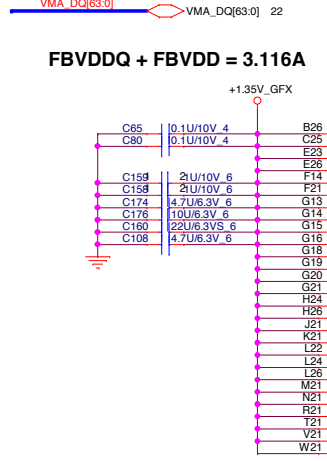

For support GC6

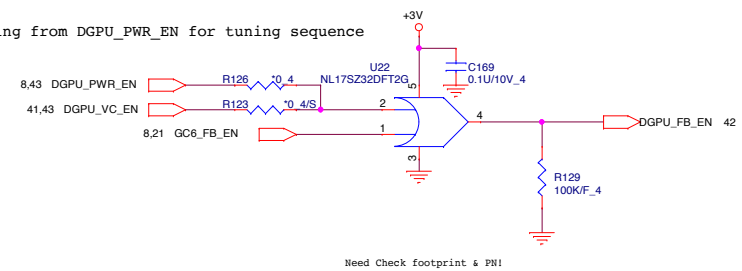

Need Check footprint & PIN!

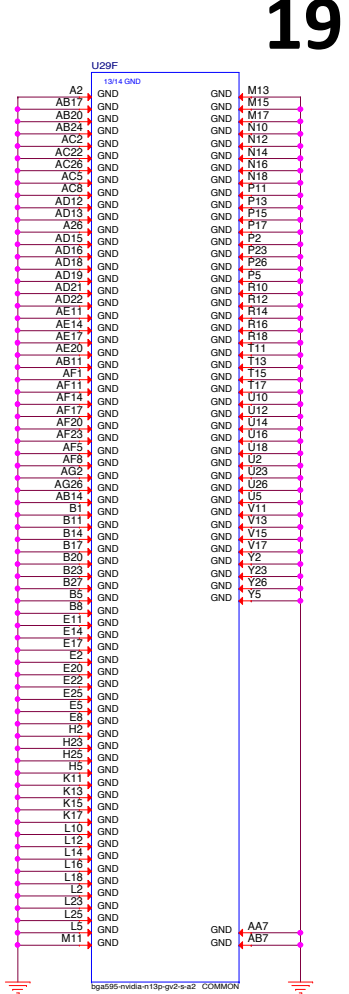

**PROJECT :U82**  
Quanta Computer Inc.

Size Custom	Document Number <b>N14M-GS (MEMORY/GND)</b>	Rev <b>2A</b>
Date: Wednesday, April 02, 2014 Sheet 19 of 44		

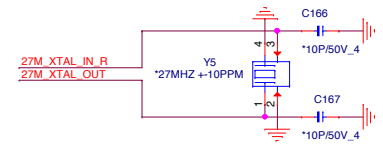
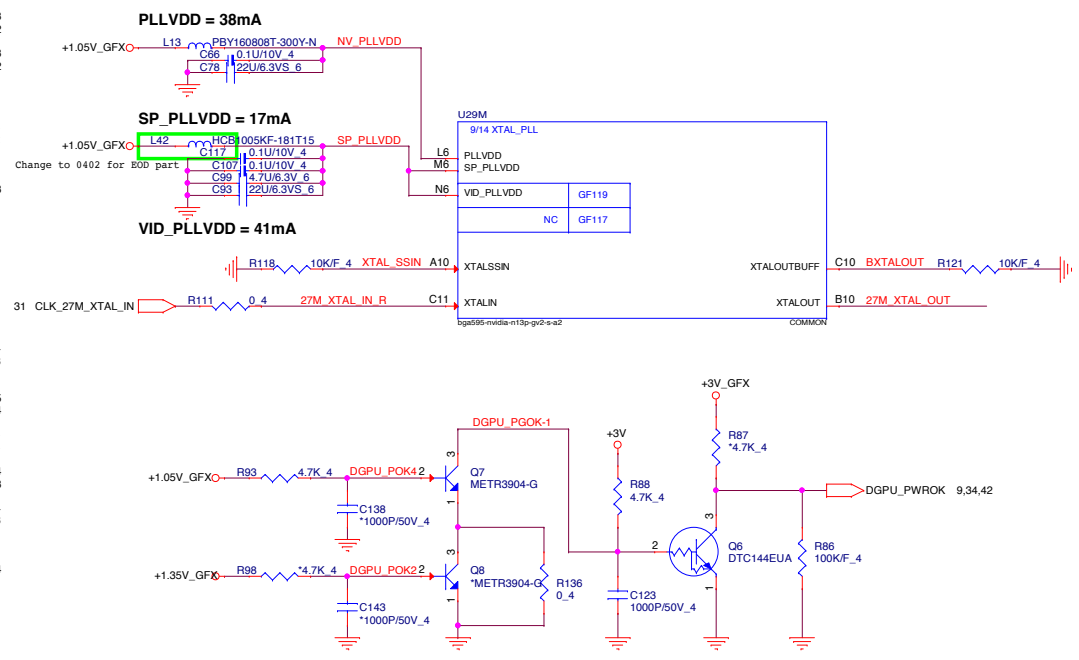
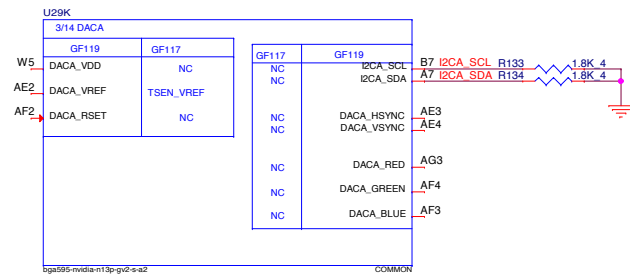
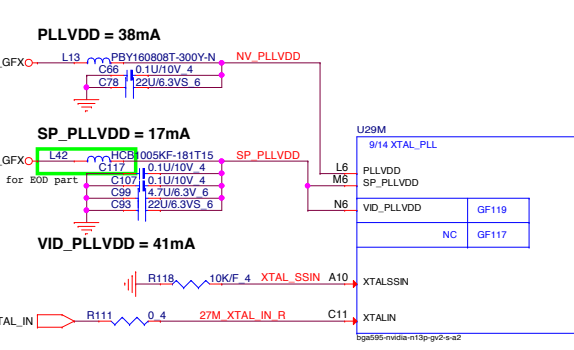
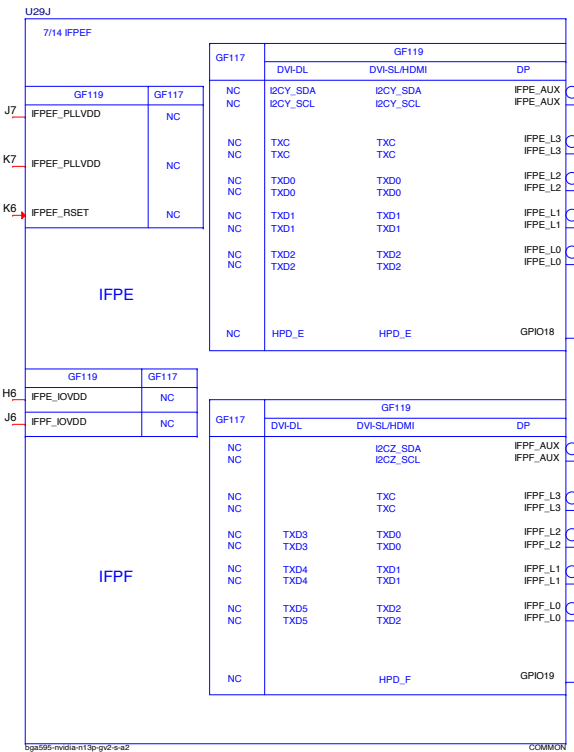
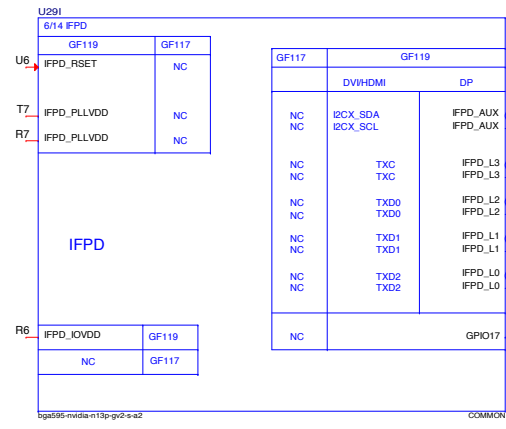
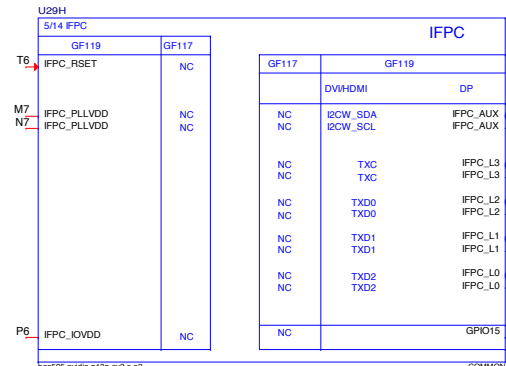
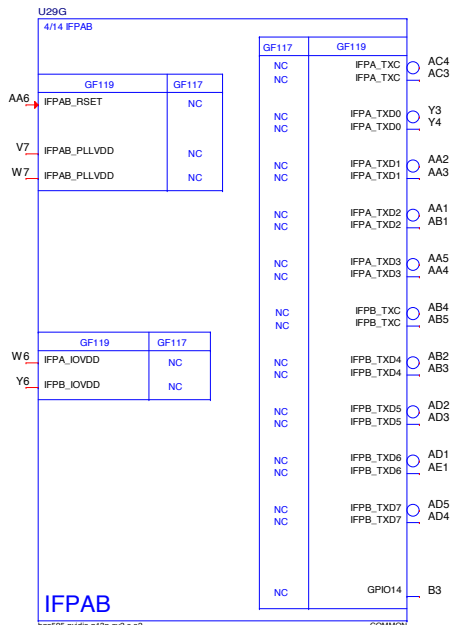

	<b>PROJECT :U82</b>	
	Quanta Computer Inc.	
	Size Custom	Document Number N14M-GS (DISPLAY)
Date: Monday, April 07, 2014 Sheet 20 of 44		

N13P-GV2 NVDD HW BOOT Voltage = 0.875V  
VID = 110010

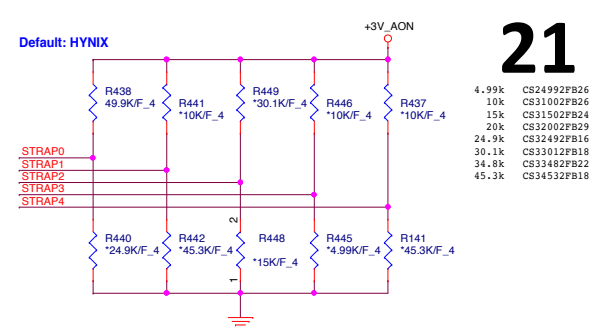
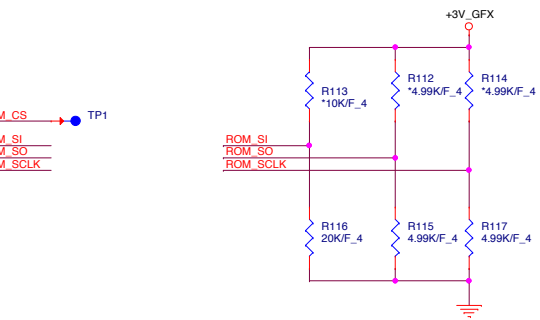
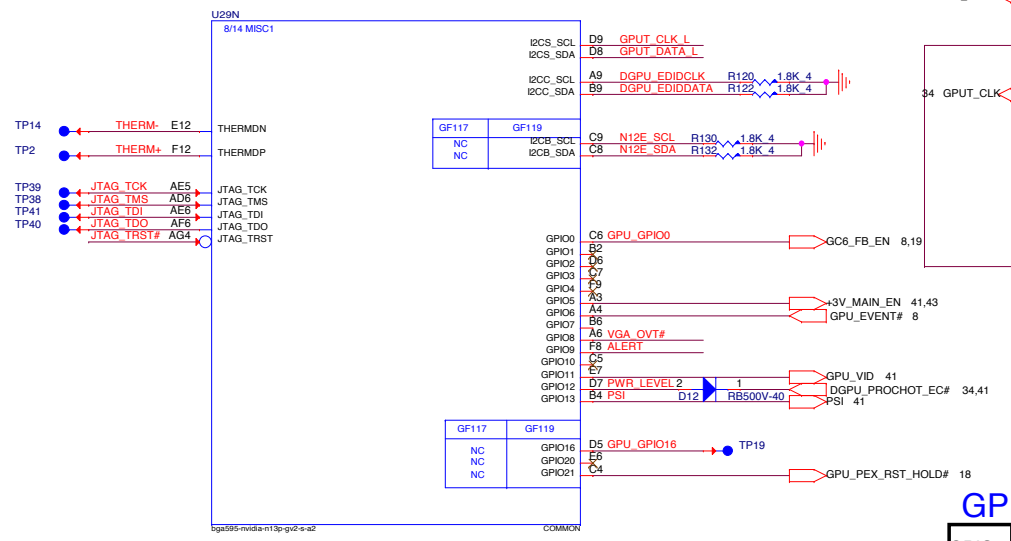
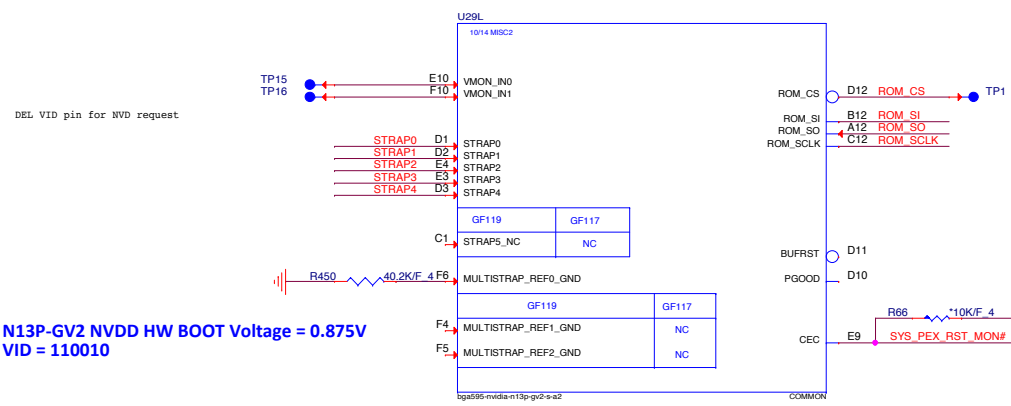
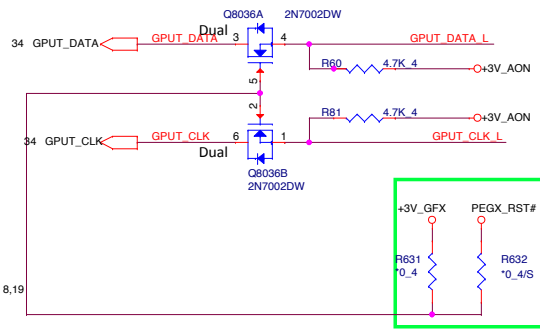

Table 15-2. Resistance Mapping to Hex Values

Resistor Values	Pull-Up to 3V3_MAIN	Pull-Down to GND
4.99 kΩ	1000	0000
10.0 kΩ	1001	0001
15.0 kΩ	1010	0010
20.0 kΩ	1011	0011
24.9 kΩ	1100	0100
30.1 kΩ	1101	0101
34.8 kΩ	1110	0110
45.3 kΩ	1111	0111

Hynix should be 0x3, R440 20K 1%  
Micro Should be 0x4, R440 24.9K 1%  
Samsung Should be 0x5, R440 30.1K 1%



VRAM Configuration Table

RAMCFG [3:0]	DESCRIPTION	Vendor	Vendor P/N	QCI P/N	QBC	TOP B/S
0000						
0100	DDR3 256Mx16, 64bit, 4Gb,900MHz	Micron	MT41J256M16HA-093G:E	S-M	AKD5PZSTL01	AKD5PZSTL00
0011	DDR3 256Mx16, 64bit, 4Gb,900MHz	HYNIX	H5TC4G63AFR-11C		AKD5PGWT08	AKD5PGWT07
0101	DD3L 256Mx16, 64bit, 4Gb,900MHz	SAMSUNG	4W4G1646D-BC1A	AKD5PGWT500		

### GPIO ASSIGNMENTS

GPIO	I/O	PIN	USAGE
0	IN	FB_CLAMP_MON	FB Clamp monitor
1	OUT	MEM_VDD_CTL	Memory VDD VID
2	OUT	LCD_BL_PWM	Panel Backlight PWM
3	OUT	LCD_VCC	PANEL POWER ENABLE
4	OUT	LCD_BLEN	PANEL BACKLIGHT ENABLE
5	OUT	Reserved	--
6	OUT	FB_CLAMP_TGL_REQ	Active low FB Clamp toggle request
7	OUT	3D VISION	3D VISION LEFT/RIGHT signal
8	I/O	OVERT	ACTIVE LOW THERMAL OVERT
9	I/O	ALERT	ACTIVE LOW THERMAL ALERT
10	OUT	MEM_VREF_CTL	MEMORY VREF CONTROL
11	OUT	PWR_VID	GPU CORE_VDD PWM Control signal
12	IN	PWR_LEVEL	AC Power detect or power supply overdraw input
13	OUT	PSI	Phase Shedding

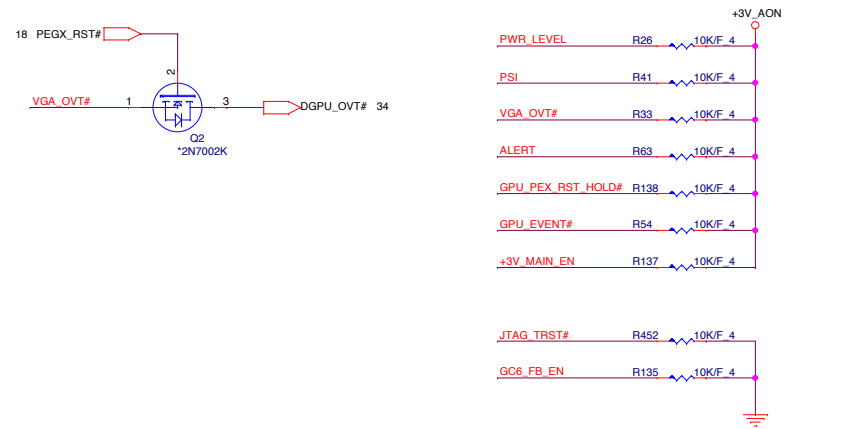

**PROJECT :U82**  
Quanta Computer Inc.

Size Custom	Document Number <b>N14M-GS (GPIO/STRAPS)</b>	Rev <b>2A</b>
Date: Tuesday, April 08, 2014 Sheet 21 of 44		

# CHANNEL A: 256MB/512MB DDR3

HYU 256Mx16, PN : AKD5PGWTW08---AKD5PGWTW07  
HYU 128Mx16, PN : AKD5MZDWTW03---AKD5MZDWTW02  
SAM 256Mx16, PN : AKD5PZDT501---AKD5PZDT500  
SAM 128Mx16, PN : AKD5MGGT535---AKD5MGGT534

19 VMA\_DQ[63..0]  
19 VMA\_DM[7..0]  
19 VMA\_WDQS[7..0]  
19 VMA\_RDQS[7..0]

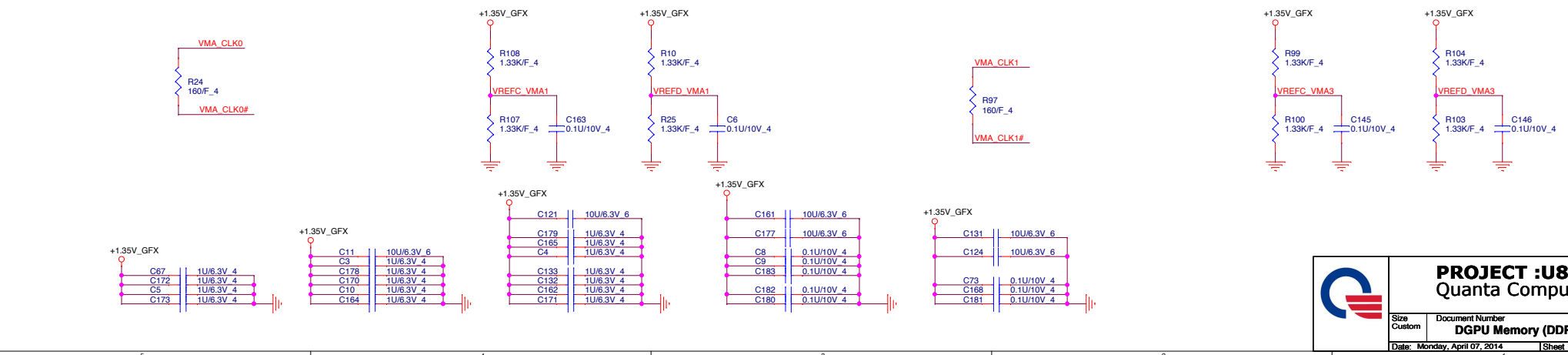
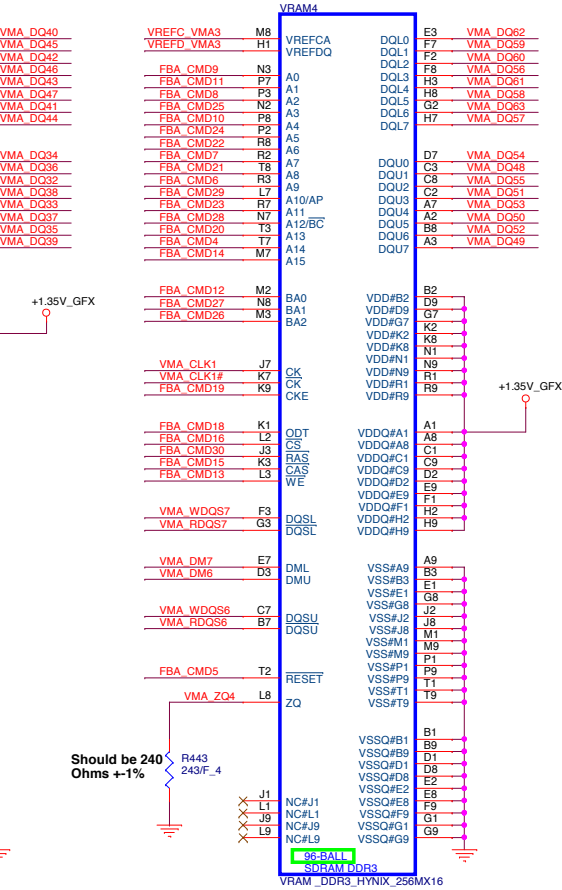
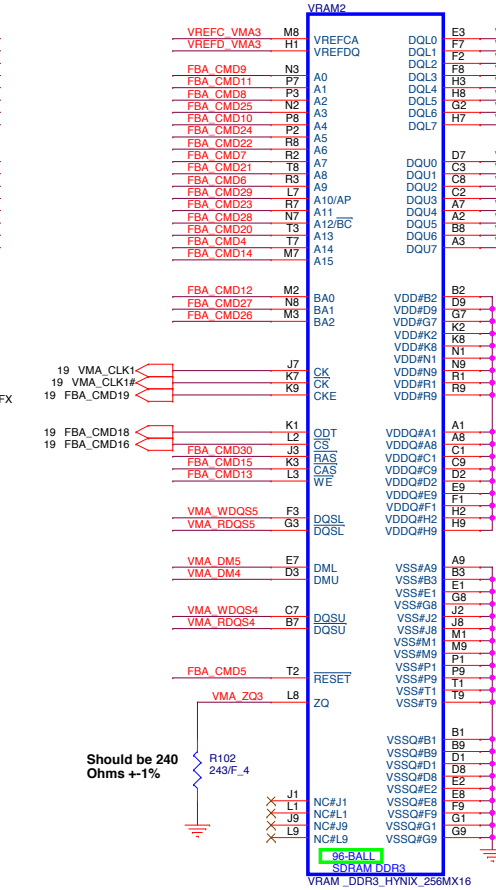
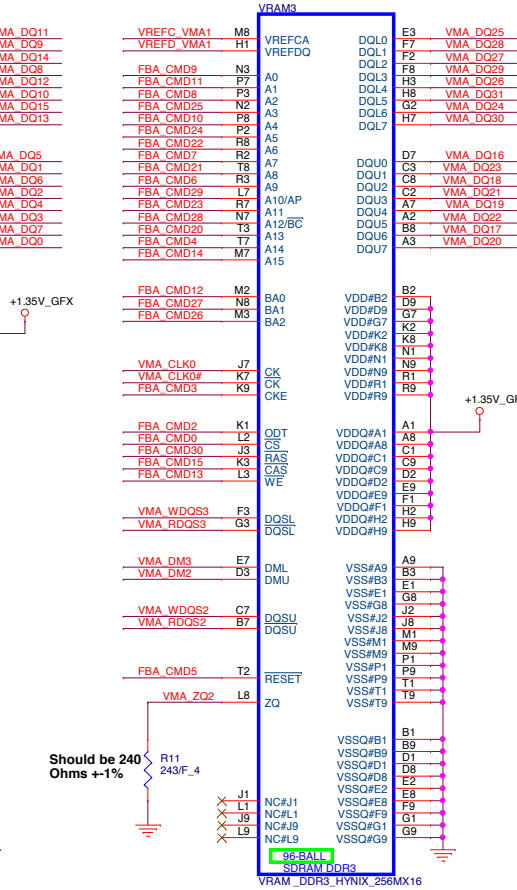
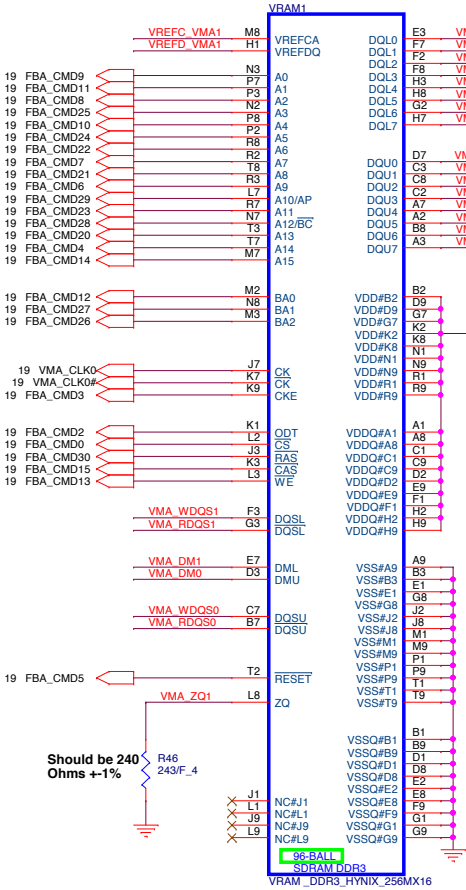

**PROJECT :U82**  
Quanta Computer Inc.

Size Custom	Document Number DGPU Memory (DDR3)	Rev 2A
Date: Monday, April 07, 2014	Sheet 22 of 44	

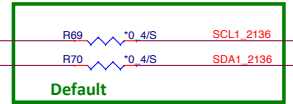
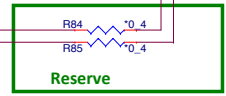
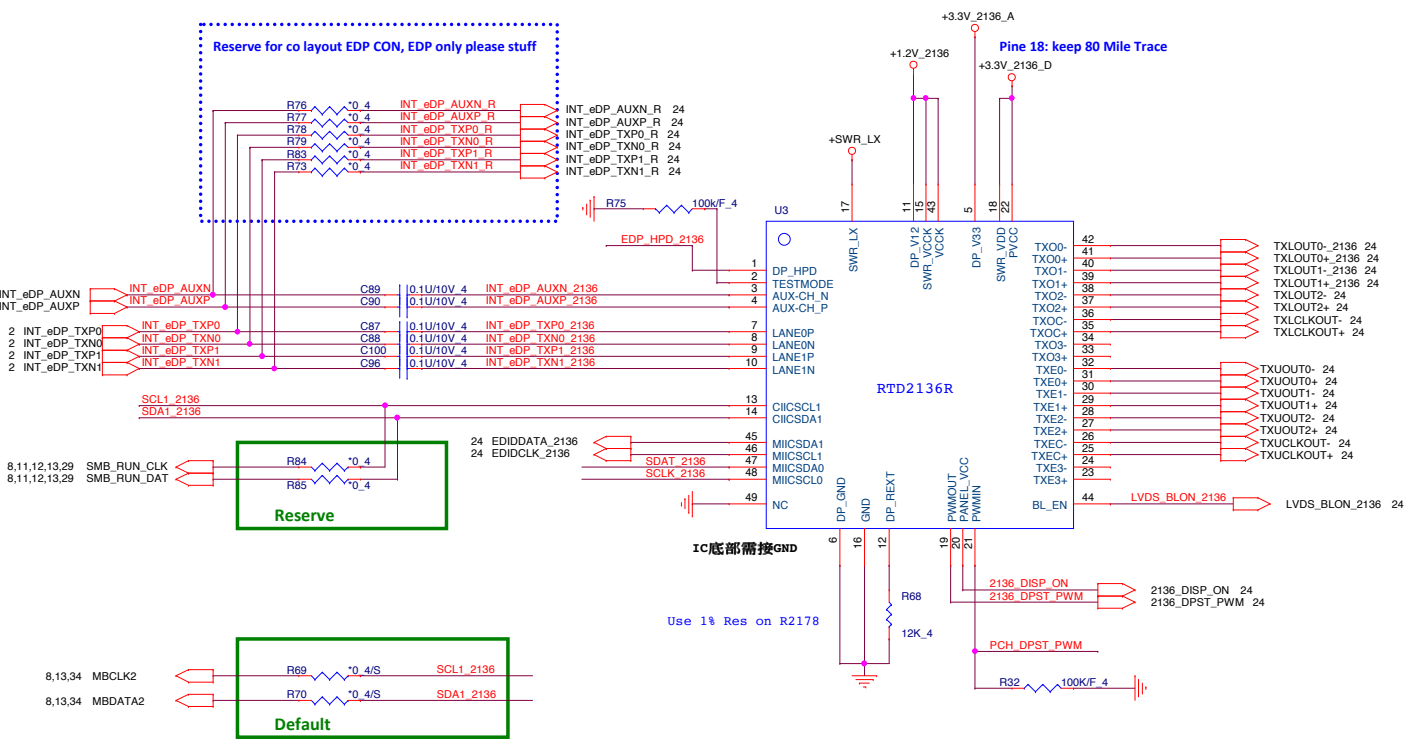
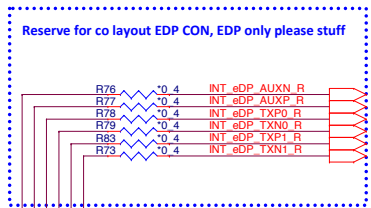
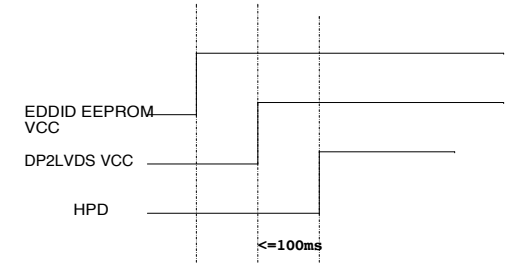

IC底部需接GND

Use 1% Res on R2178

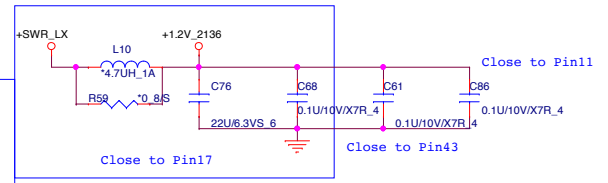
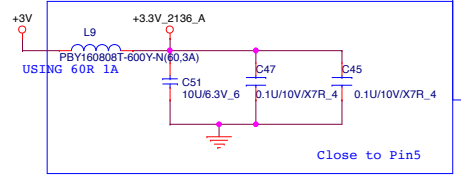
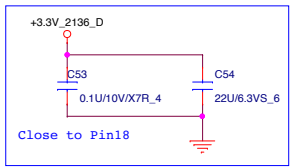
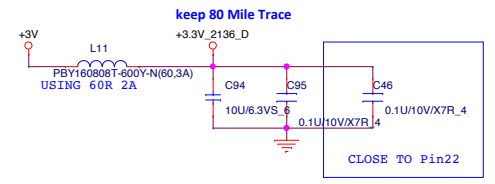
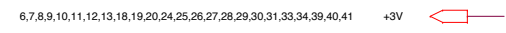
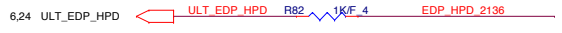
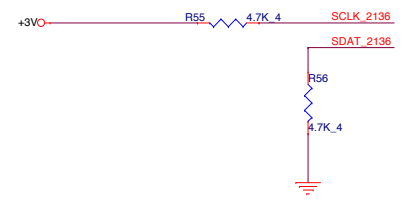

SWR MODE	LDO MODE
Stuff L8	Stuff R86

# LID Switch

## LVDS Conn.

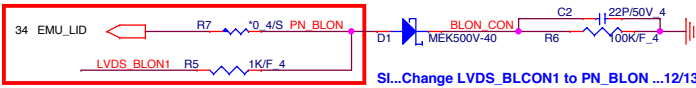

SI...Change LVDS\_BLON1 to PN\_BLON ...12/13

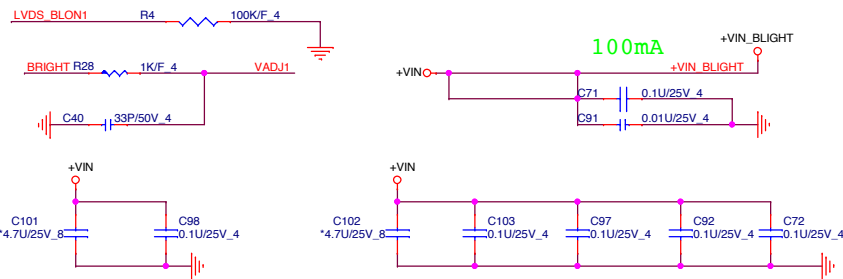

100mA

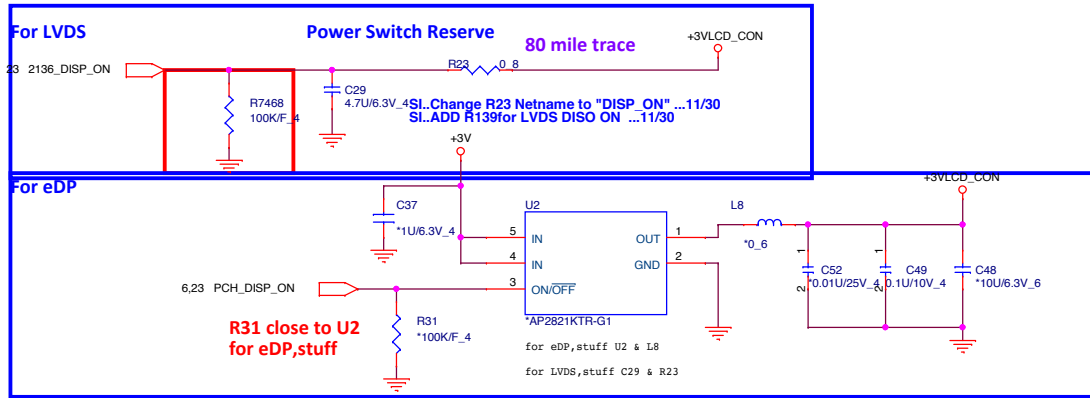

R31 close to U2 for eDP,stuff

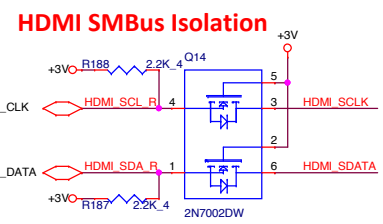
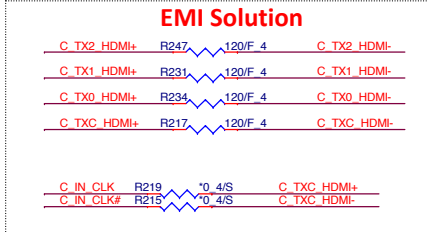

For EDP Only: stuff Cap  
For LVDS only stuff Resistor

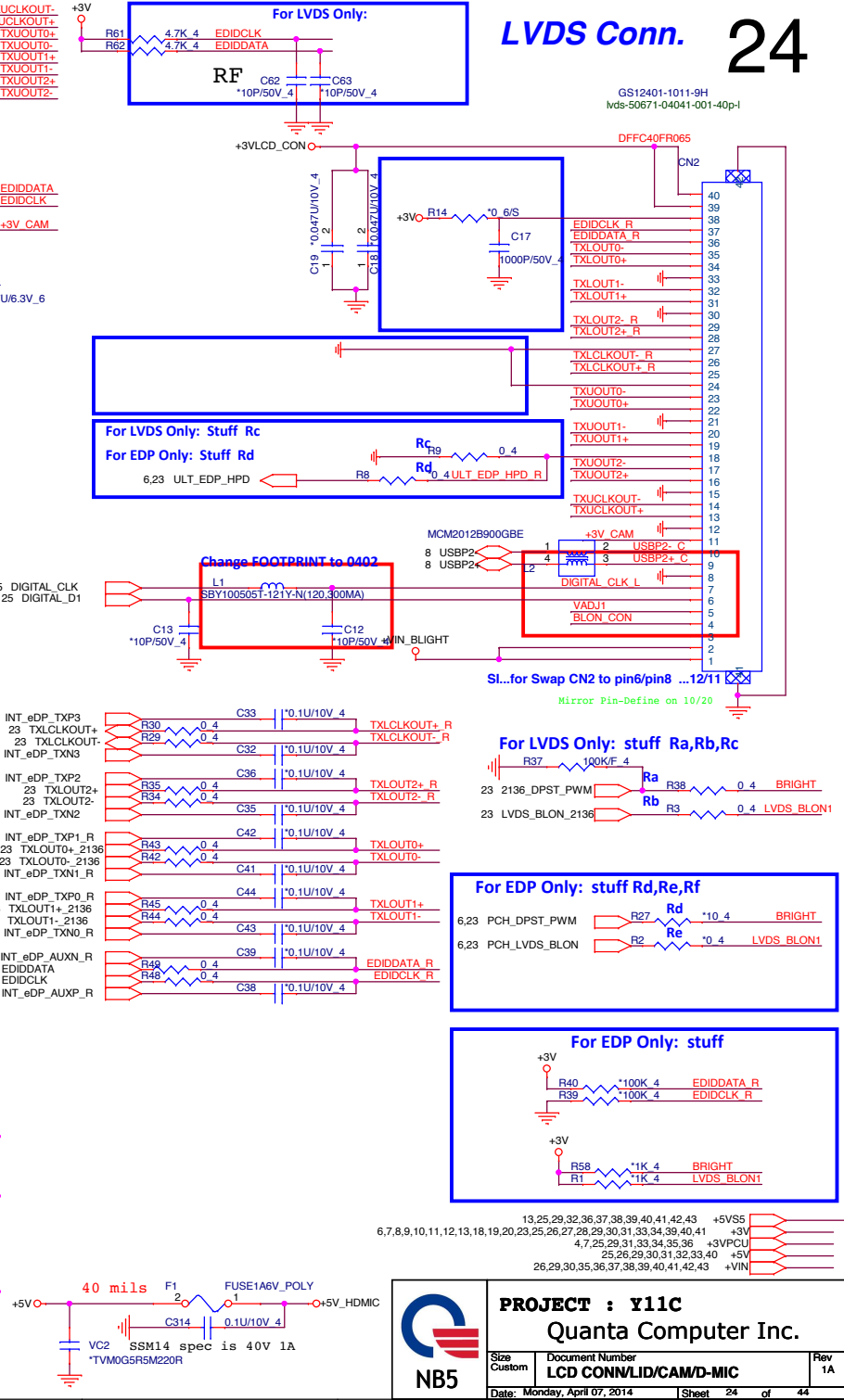
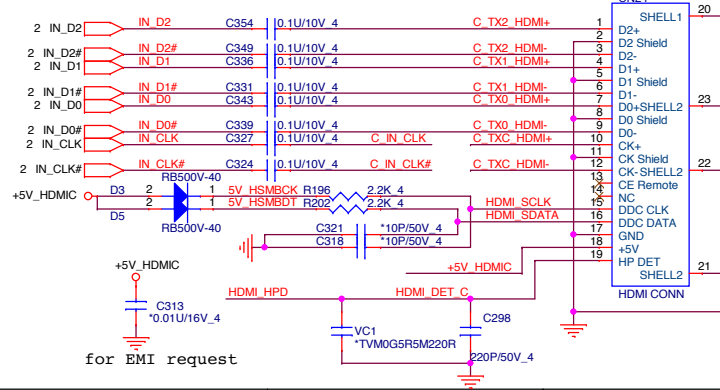
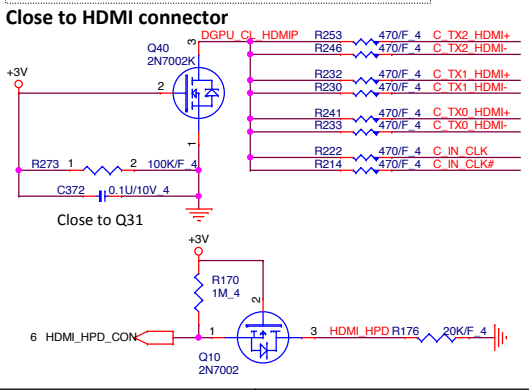

For LVDS Only: stuff Ra, Rb, Rc

For EDP Only: stuff Rd, Re, Rf

For EDP Only: stuff

**PROJECT : Y11C**  
**Quanta Computer Inc.**

Size Custom Document Number LCD CON/LID/CAM/D-MIC Rev 1A

Date: Monday, April 07, 2014 Sheet 24 of 44



Audio Codec

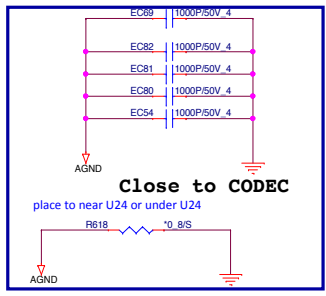
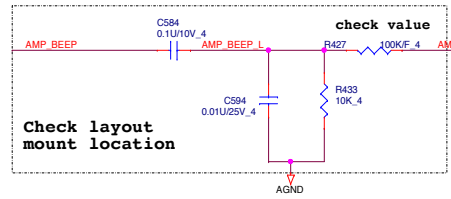
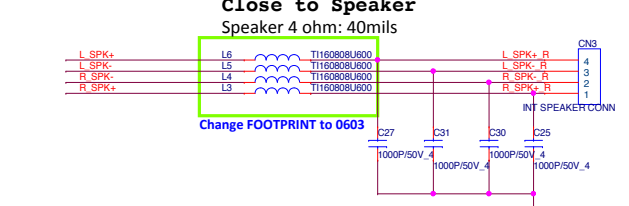
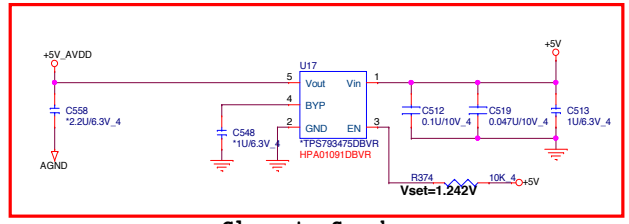
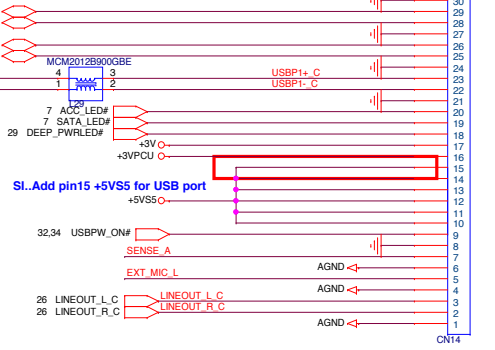
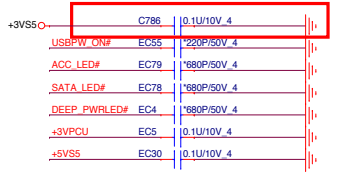
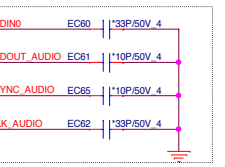
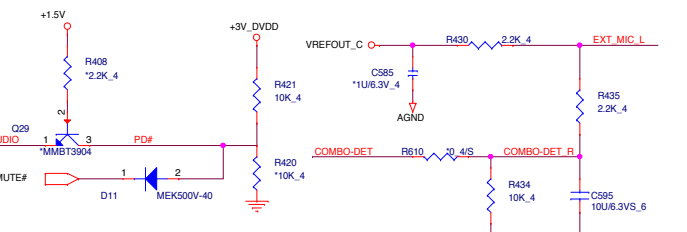
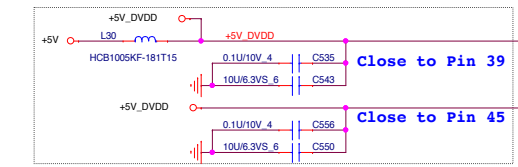
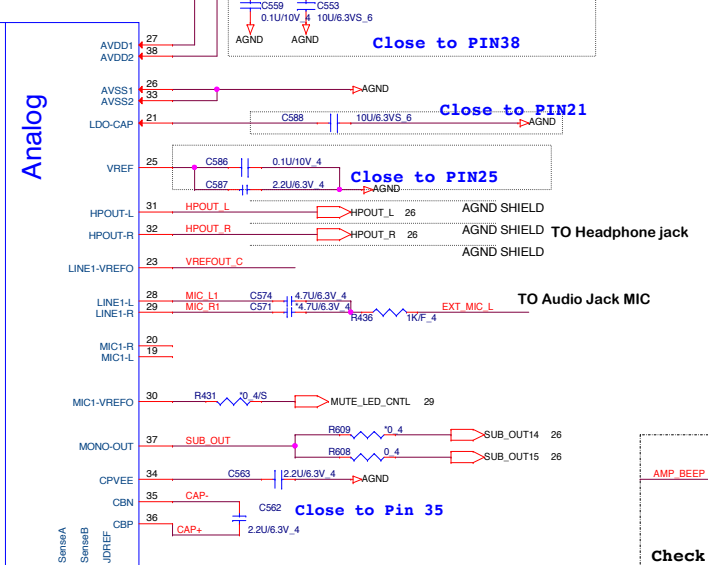
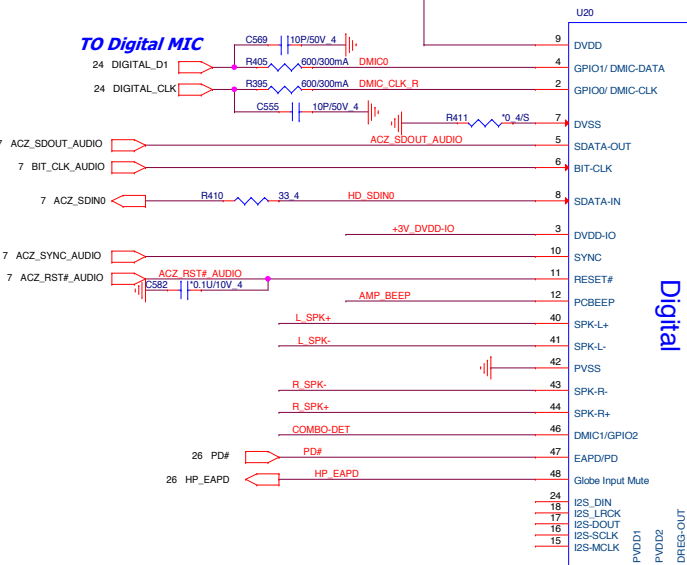
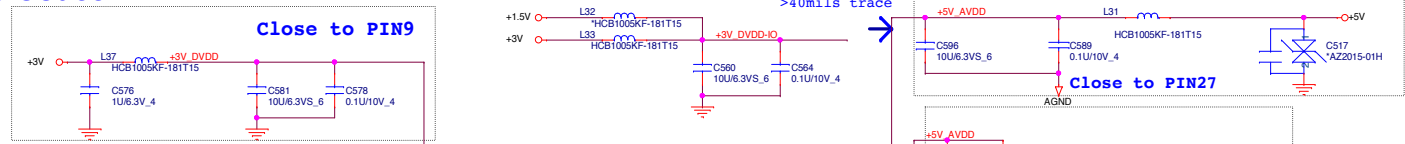

**PROJECT : Y11C**  
**Quanta Computer Inc.**

Size Custom Document Number Audio Codec Rev 1A  
 Date: Wednesday, April 02, 2014 Sheet 25 of 44



For EMI 0 ~ 22 ohm

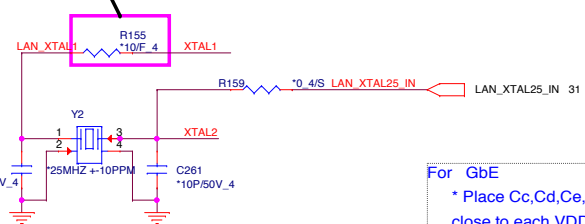

For GbE  
 \* Place Cc,Cd,Ce,Cf,C232  
 close to each VDD10 pin-- 3, 22, 8, 30

For 10/100 NA Ce,Cf  
 \* Place Ce , Cf ,C250  
 close to each VDD10 pin-- 8, 30 only,

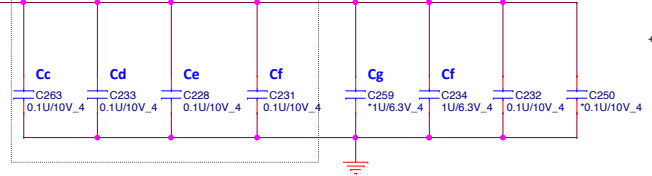

For GbE  
 \* Place Cf close to each VDD10 pin-- 22 (reserve)

For 10/100  
 \* Place Cg close to each VDD10 pin-- 30 (reserve)

>60mil  
 Trace<30 mil  
 Width > 60 mil

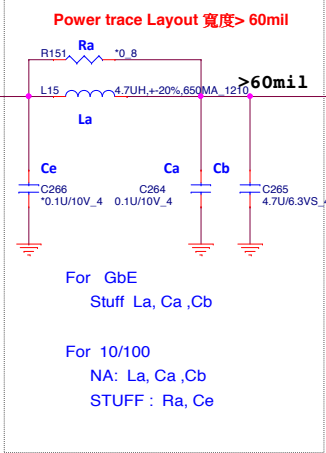

For GbE  
 Stuff La, Ca ,Cb  
 For 10/100  
 NA: La, Ca ,Cb  
 STUFF : Ra, Ce

For 10/100  
 \* Stuff Cb and Ce only, close to each VDD33 pin-- 23, 32  
 For GIGA  
 \* Stuff Ca and Cb only, close to each VDD33 pin-- 11, 32

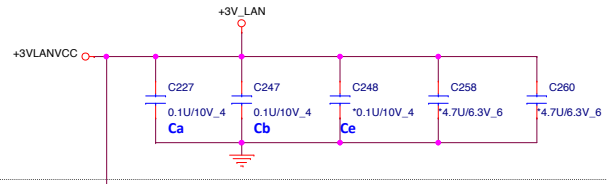

\* Place Cc and Cd close to each VDD33 pin-- 23  
 For GIGA  
 Stuff Cc ,Cd  
 For 10/100  
 NA: Cc, Cd  
 Remove For Not Using SWR mode

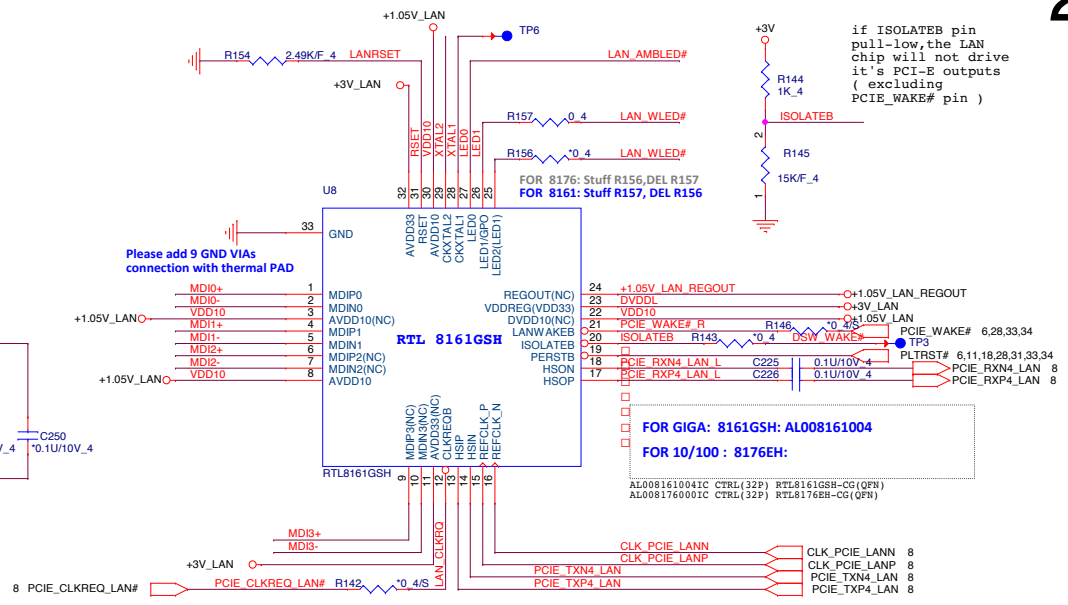

if ISOLATEB pin  
 pull-low, the LAN  
 chip will not drive  
 it's PCI-E outputs  
 ( excluding  
 PCIE\_WAKE# pin )

FOR GIGA: 8161GSH: AL008161004  
 FOR 10/100 : 8176EH:

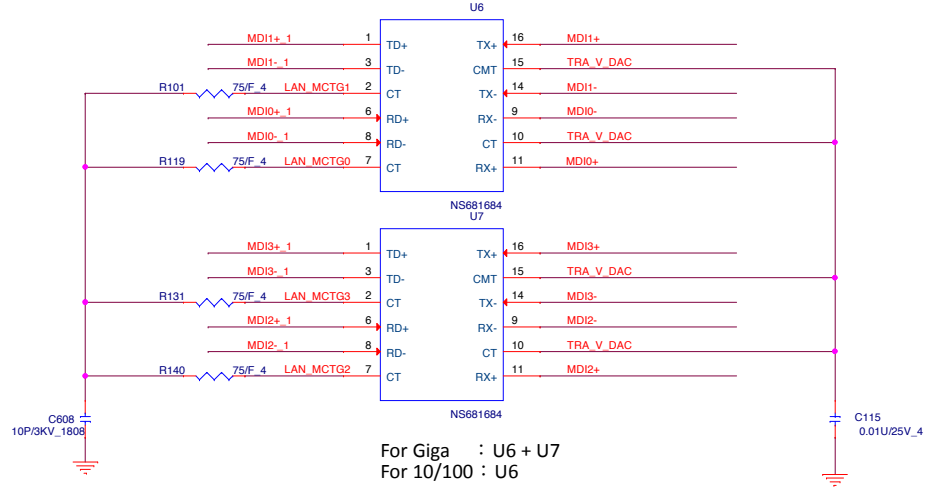
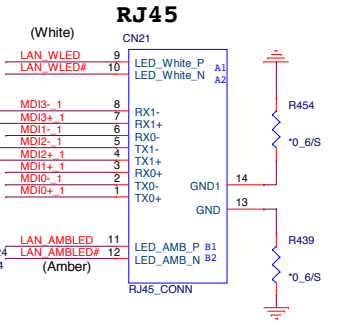
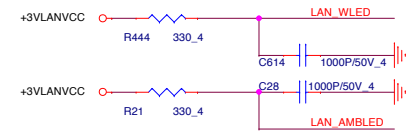

For Giga : U6 + U7  
 For 10/100 : U6

**PROJECT : Y11C**  
**Quanta Computer Inc.**

Size Custom Document Number LAN RTL8161GSH /RJ45 conn Rev 1A  
 Date: Wednesday, April 02, 2014 Sheet 27 of 44

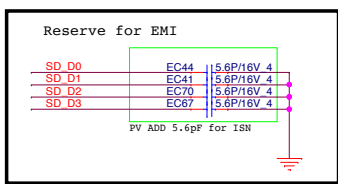
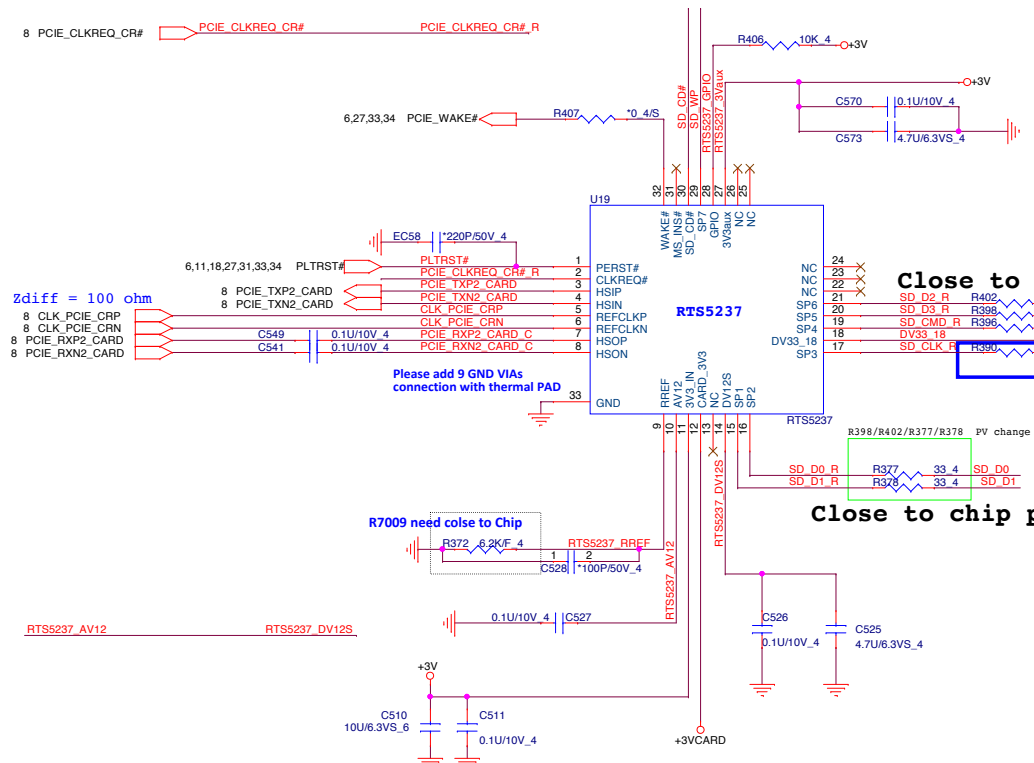

SP1	SD D1	MS D1
SP2	SD D0	MS D0
SP3	SD CLK	MS D0
SP4	SD CMD	MS D2
SP5	SD D3	MS D3
SP6	SD D2	MS CLK
SP7	SD WP	MS BS

Share Pin  
SD / MMC

Close to chip pin

Close to chip pin

CLOSE CONN

CARD READER

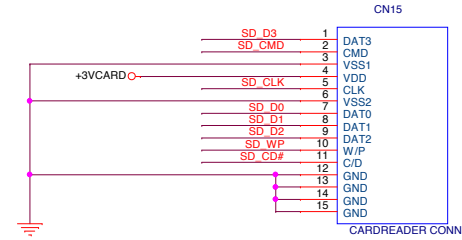

R6x Type

Thermal Nut

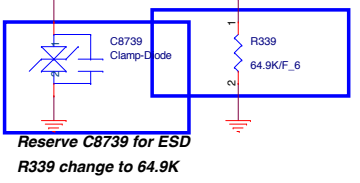
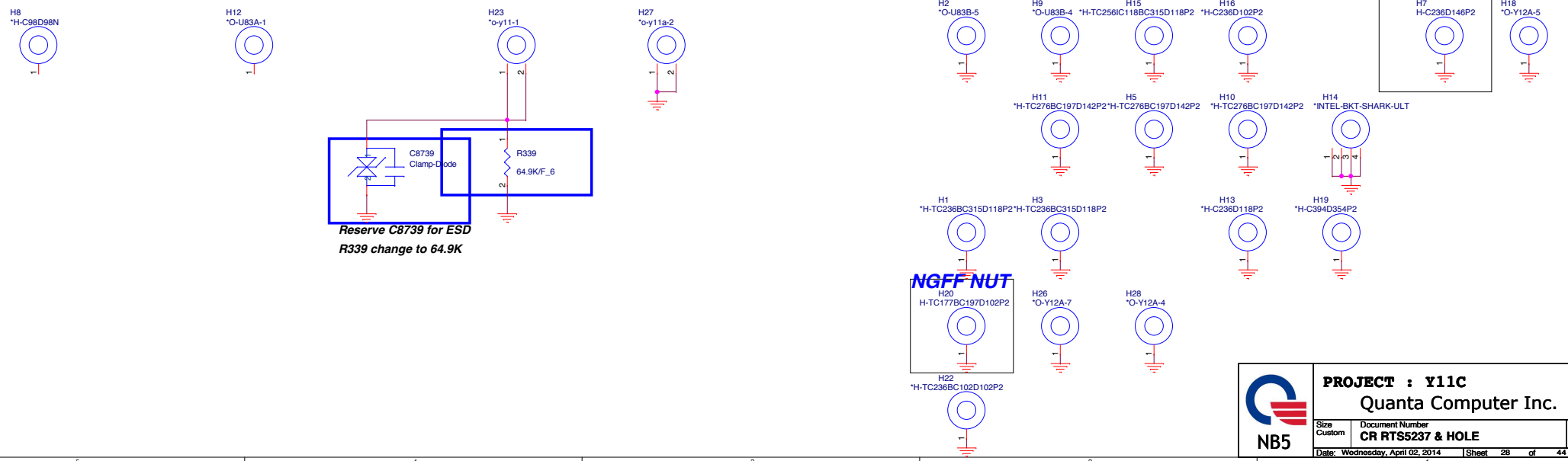

NGFF NUT

	<b>PROJECT : Y11C</b>		Rev 1A
	Quanta Computer Inc.		
	Size Custom	Document Number CR RTS5237 & HOLE	
Date: Wednesday, April 02, 2014		Sheet 28 of 44	

**Power Button Connector**

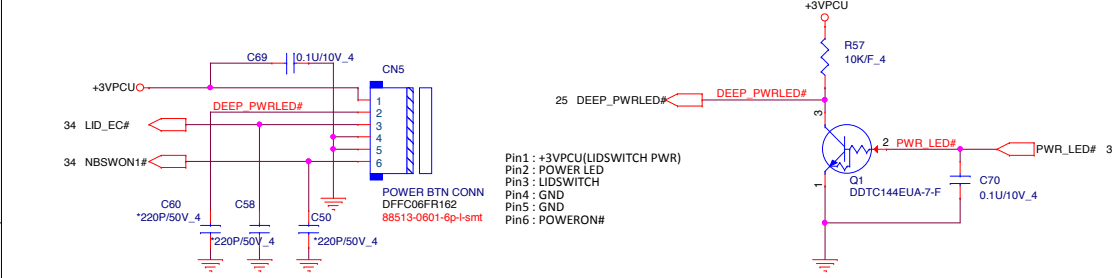

**Touch Pad Connector**

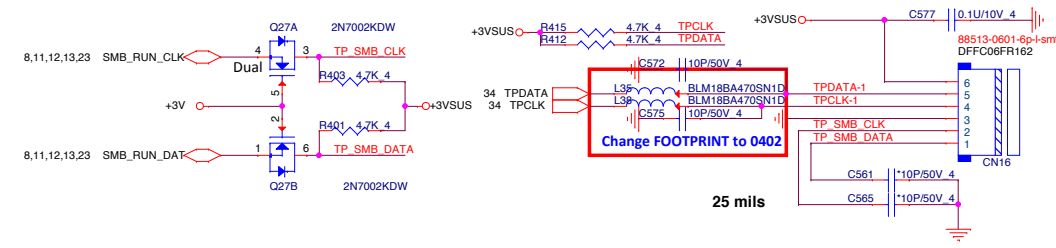

**KEYBOARD Con.**

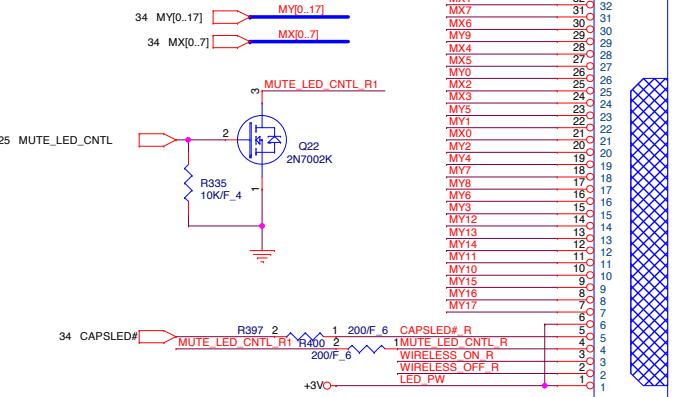

**KEYBOARD PULL-UP**

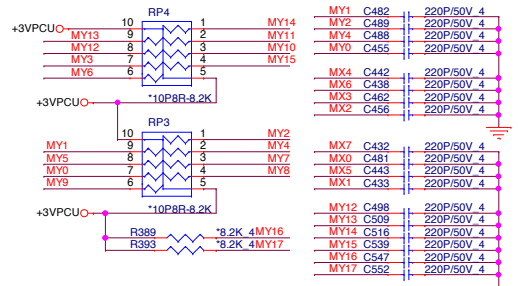

**FAN**

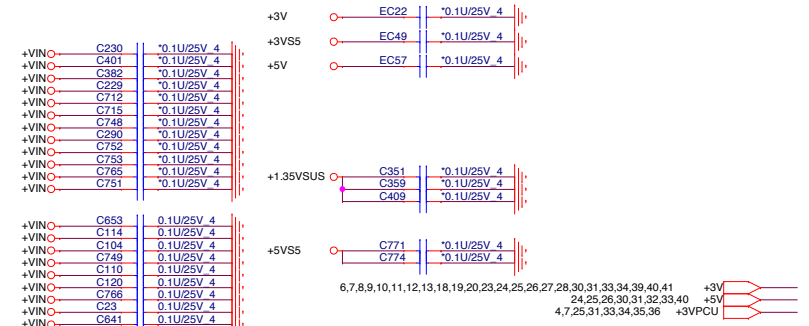
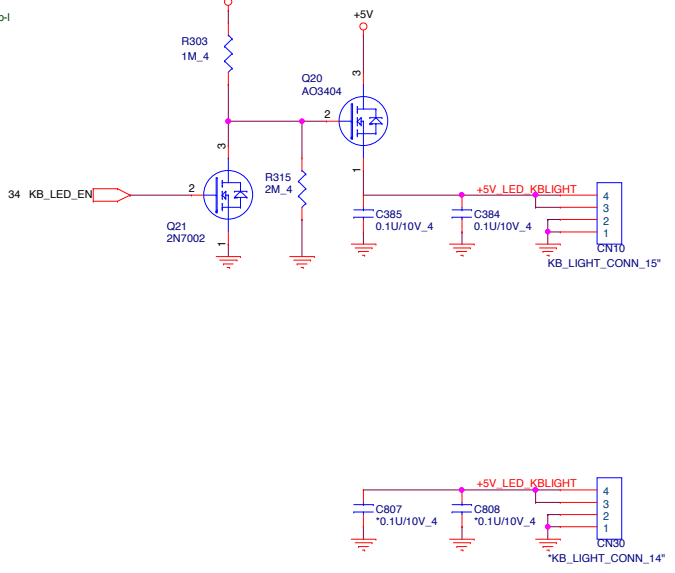
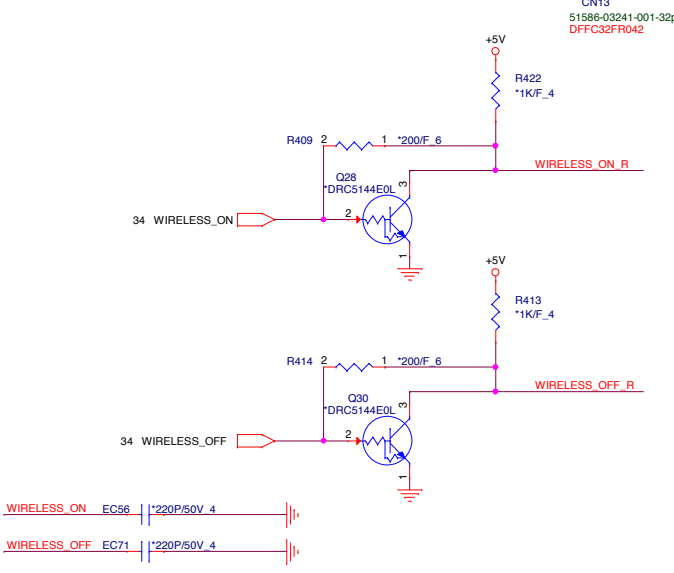
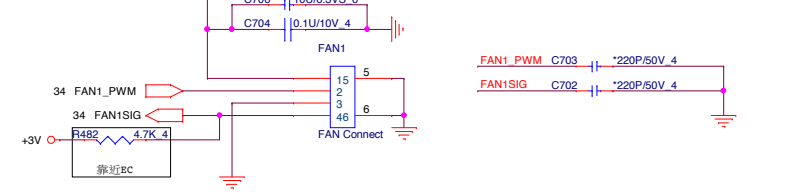

**PROJECT : Y11C**  
**Quanta Computer Inc.**

Size Custom Document Number PB/TP/KB/FAN/EMI Cap Rev 1A  
 Date: Wednesday, April 02, 2014 Sheet 29 of 44

HDD

SATA HDD Connector(Cable type) 15.6"

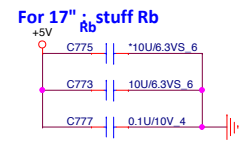
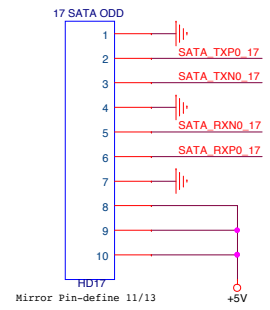
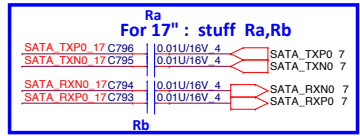

SATA ODD CONNECTOR

14" SATA ODD

Bypass CAP close conn

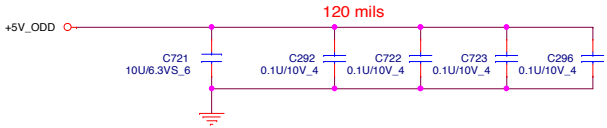
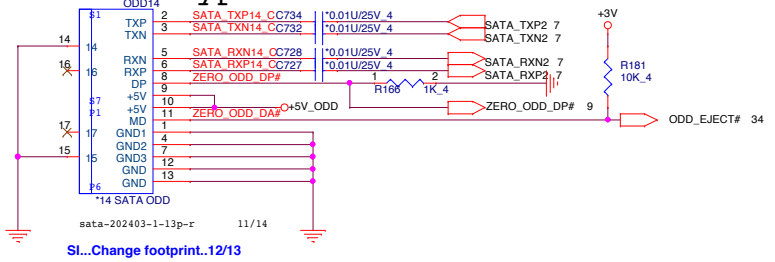

15" SATA ODD

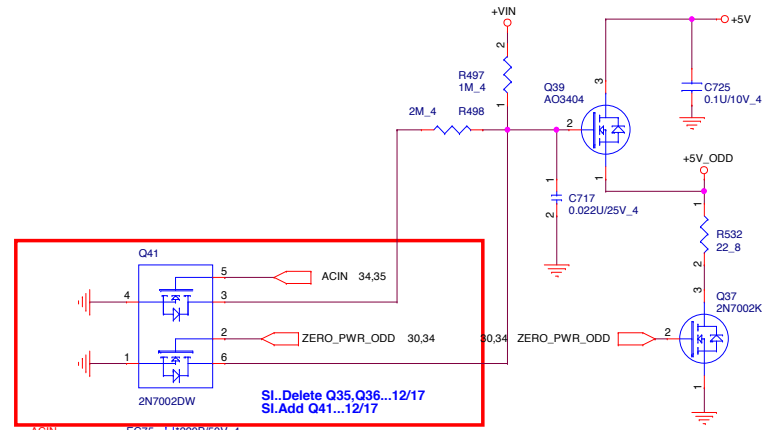
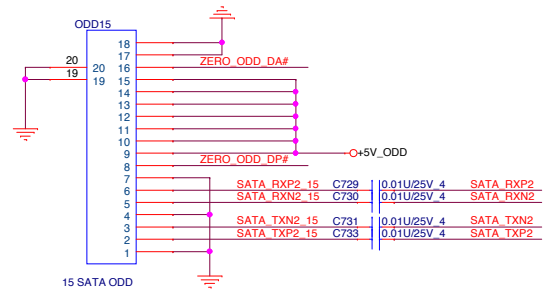

High : ODD power down  
Low : ODD power on

**PROJECT : Y11C**  
**Quanta Computer Inc.**

Size Custom	Document Number	Rev 1A
HDMI		
Date: Wednesday, April 02, 2014	Sheet 30 of 44	

TPM (1.2)

Address

	BADD
HIGH	4EH/4F (default)

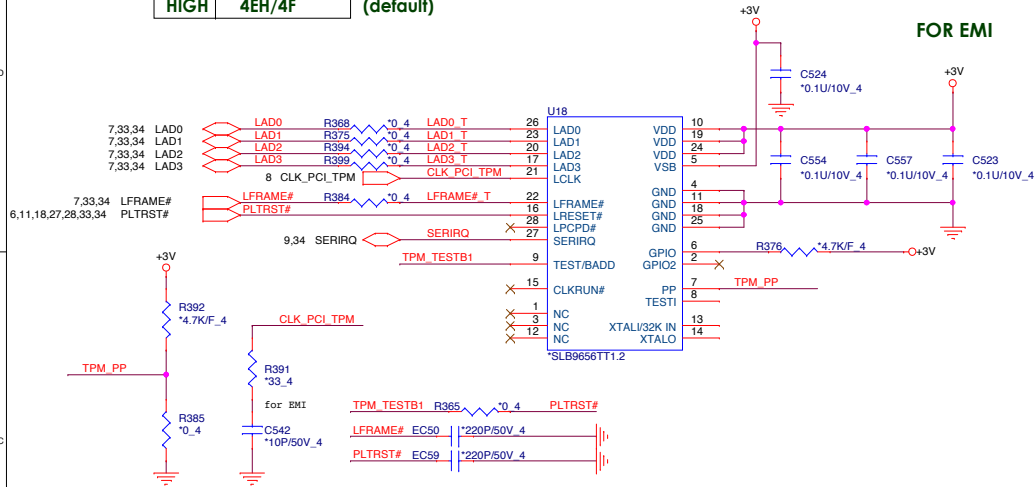

Accelerometer Sensor

沿用u82

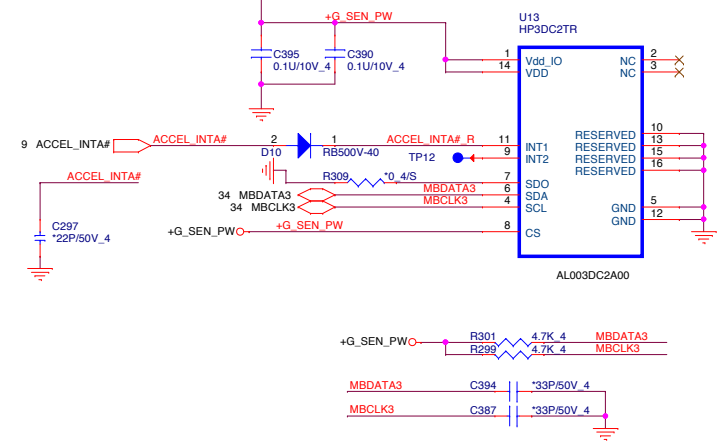

Touch screen

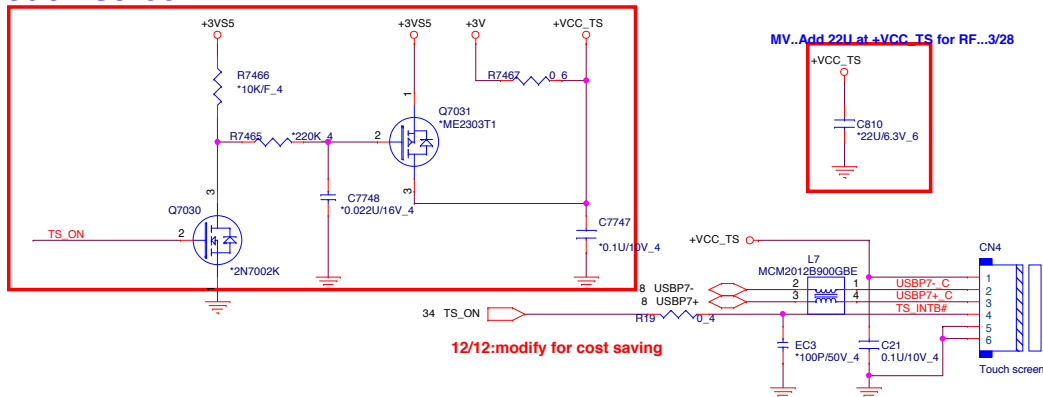

Green CLK Circuitry

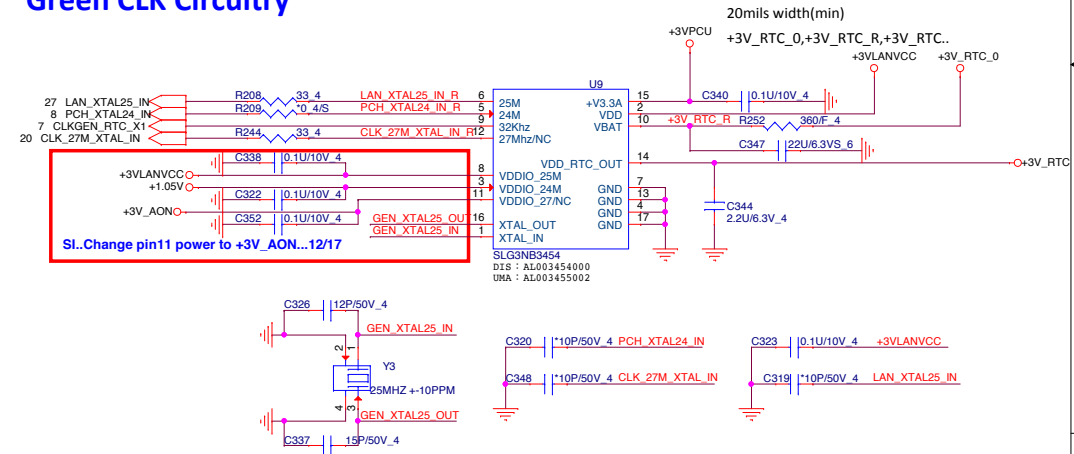

Fingerprint Conn

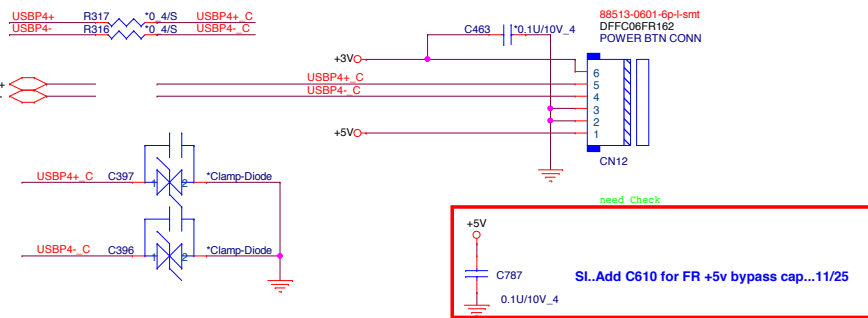

NB5	<b>PROJECT : Y11C</b>		Rev 1A
	Quanta Computer Inc.		
	Size Custom	Document Number TPM/G-Sensor/G-CLK/TS/FP	
Date: Wednesday, April 02, 2014	Sheet 31 of 44		

USB 2.0/3.0 Combo

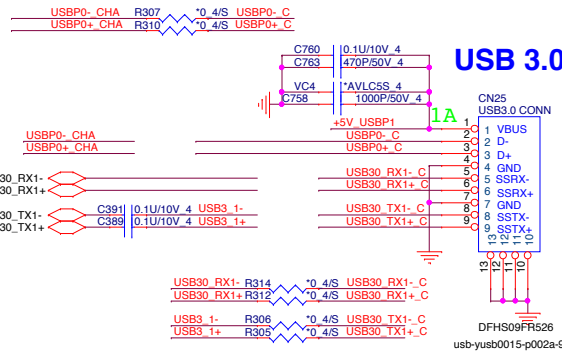
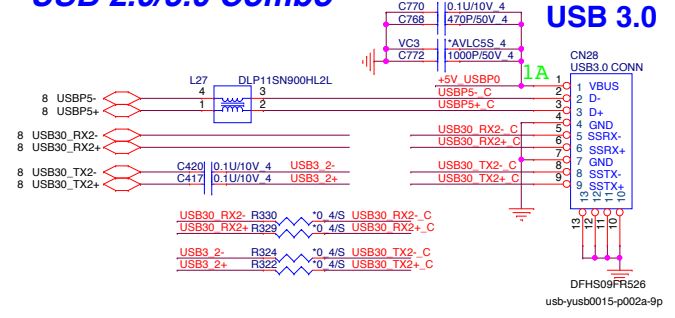

if Envy SKU, non-staff



For Pavilion / Envy SKU stuff

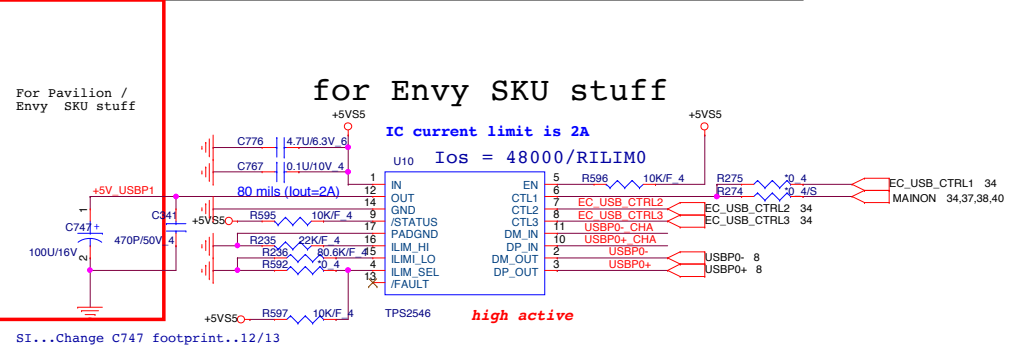

SI...Change C747 footprint..12/13

Right-Side USB3.0 Re-Driver

AEQ 9.5db / ADE 3.5db  
BEQ 13db / BDE 5db / REXT 5.36K

A_EQ1	A_EQ0	A_DE1	A_DE0	B_EQ1	B_EQ0	B_DE1	B_DE0
0	0	9.5db	0	0	0	3.5db	
0	1	13db	0	1	0	no de-emphasis	
1	0	4.5db	1	0	0	2.7db	
1	1	7.5db	1	1	1	5db	

TST : Low = Normal LFPS swing / High =Turn down LFPS swing

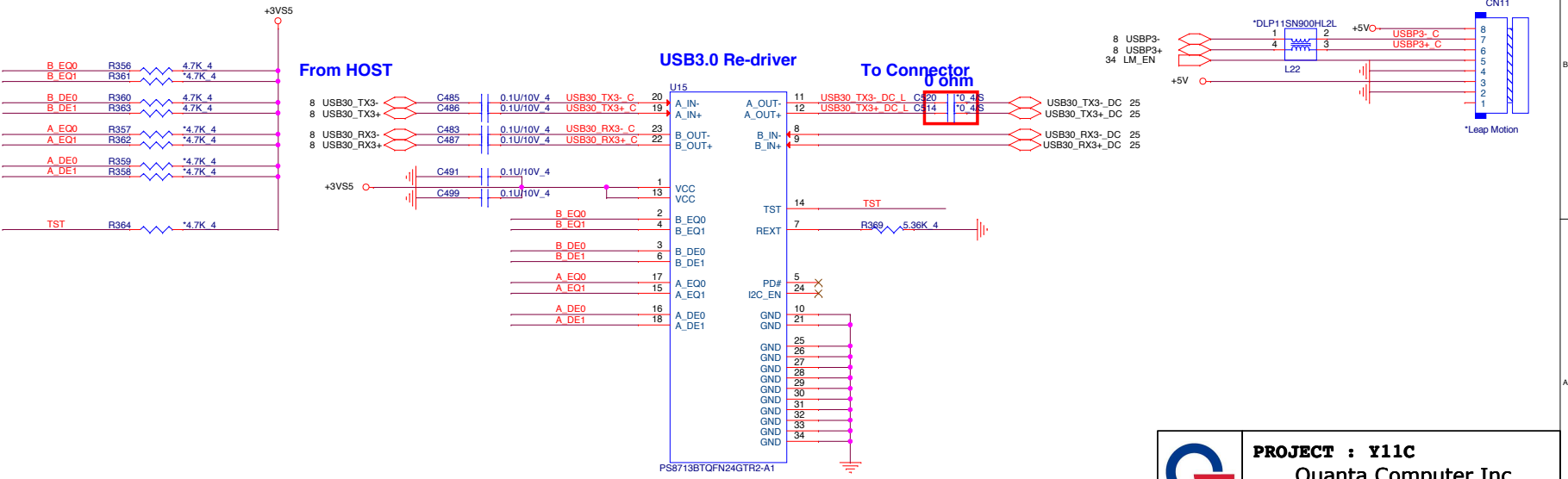

**PROJECT : Y11C**  
**Quanta Computer Inc.**

Size Custom Document Number **USB 3.0** Rev 1A

Date: Wednesday, April 02, 2014 Sheet 32 of 44





申請料號中

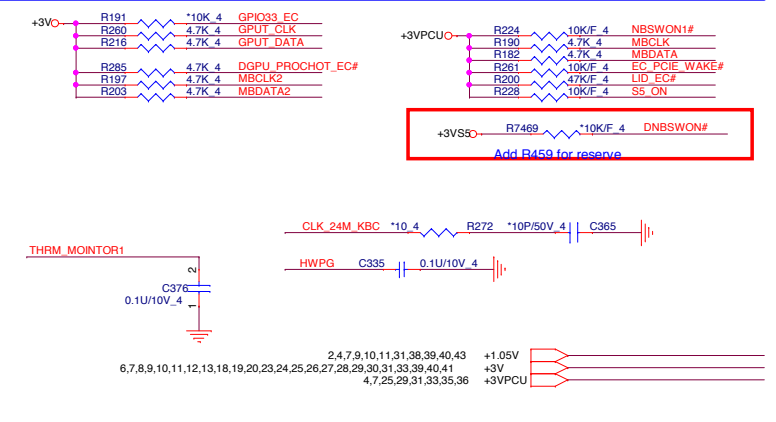
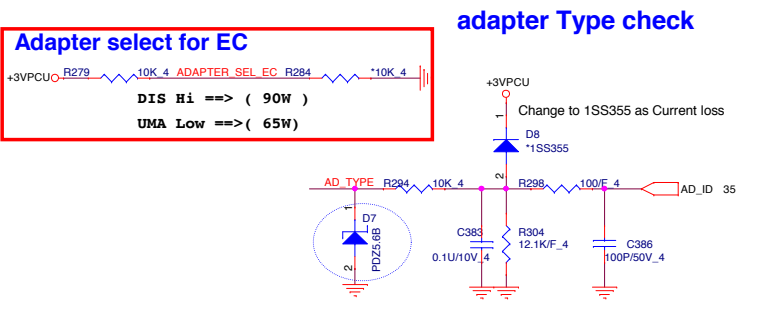
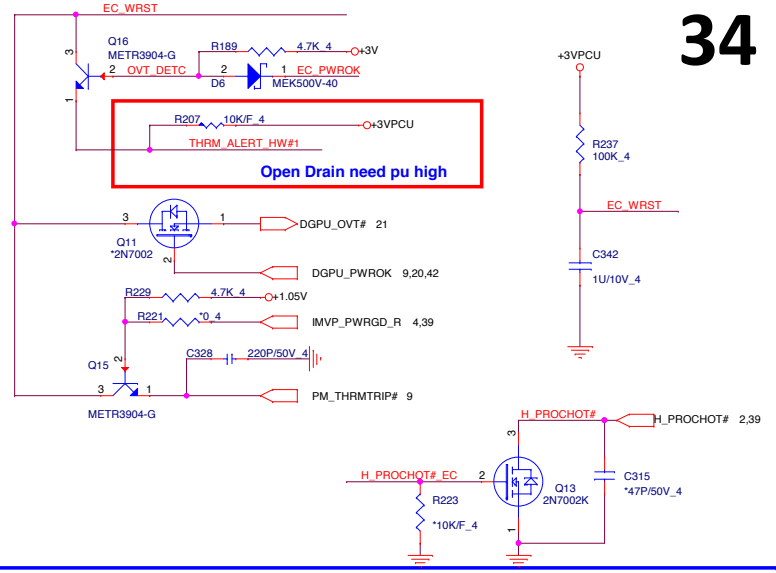
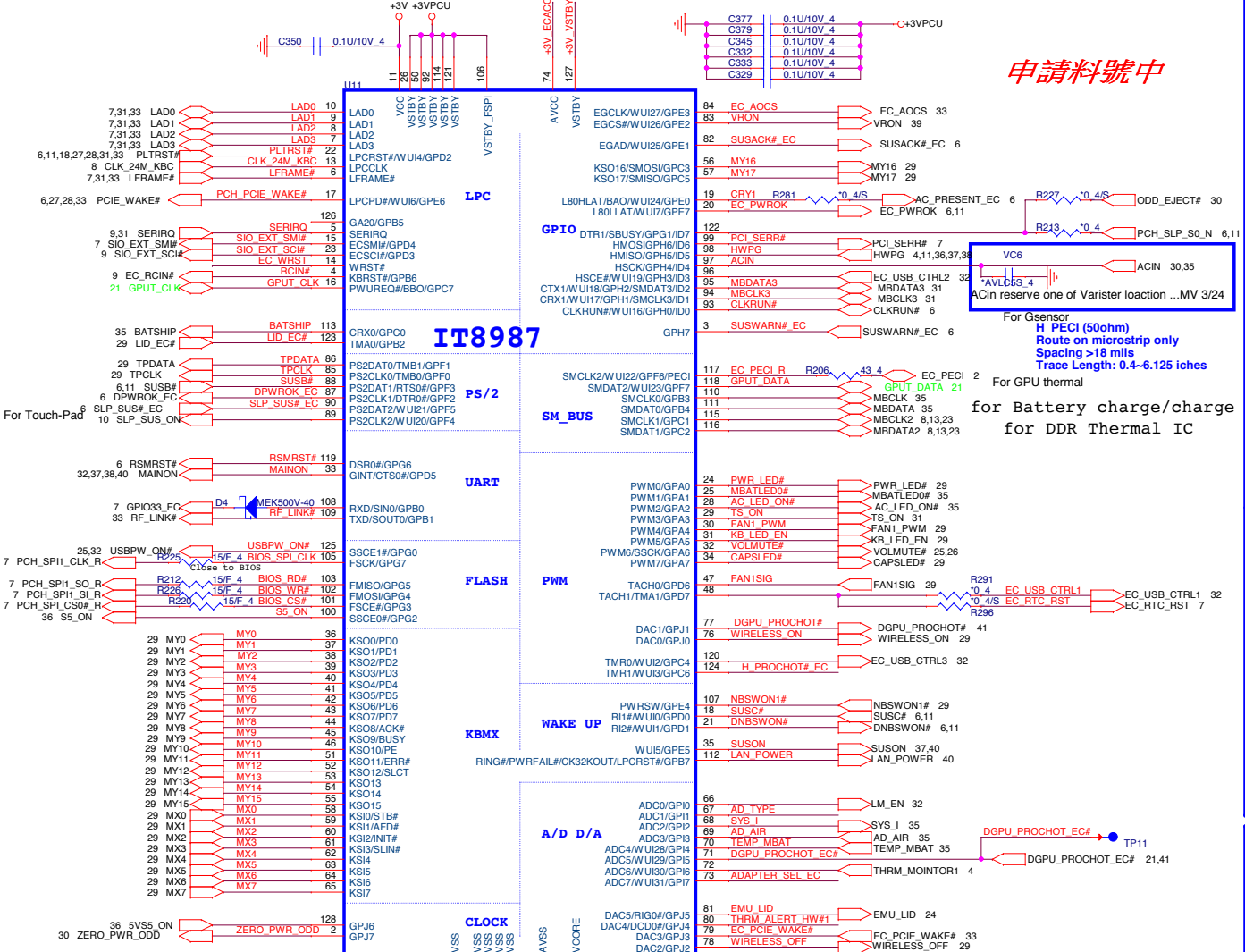

For Gsensor  
H\_PECI (50ohm)  
Route on microstrip only  
Spacing >18 mils  
Trace Length: 0.4-6.125 inches  
for Battery charge/charge  
for DDR Thermal IC

DIS Hi ==> ( 90W )  
UMA Low ==> ( 65W )

Add R459 for reserve



DC/DC +3VS5/+5VS5

**+3.3 Volt +/- 5%**  
**Countinue current:4A**  
**Peak current:6A**  
**OCP minimum:7.5A**

+3VSS [6,7,9,10,11,25,29,32,33,38,40,43]  
 +5VSS [13,25,29,32,37,38,39,40,41,42,43]

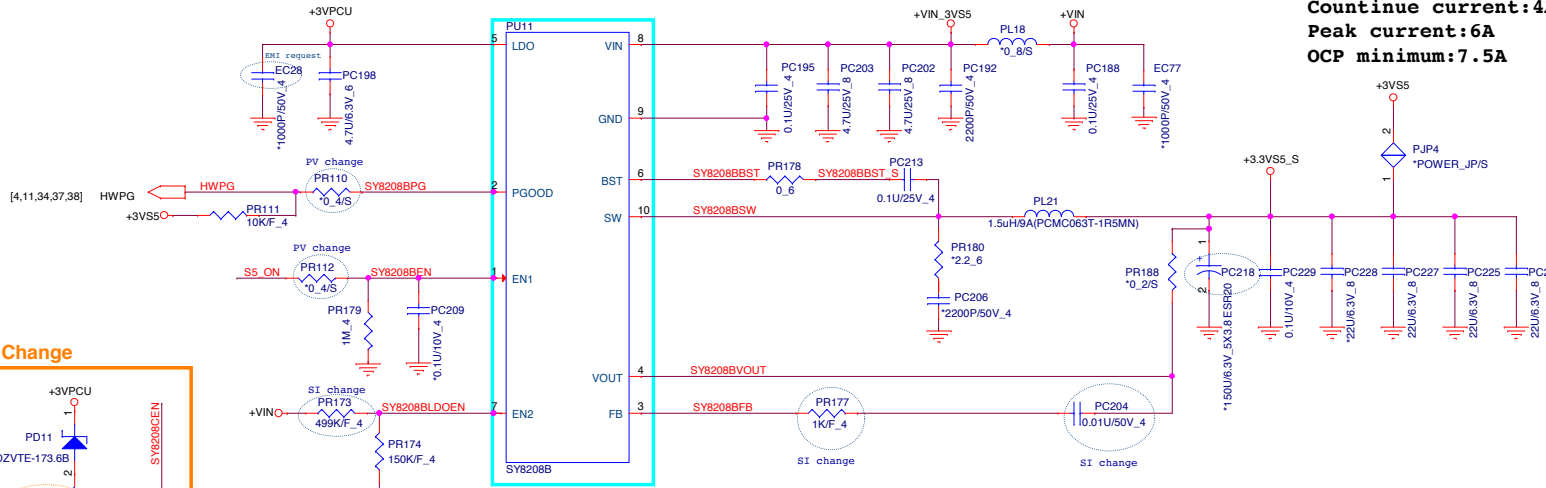

MV Change

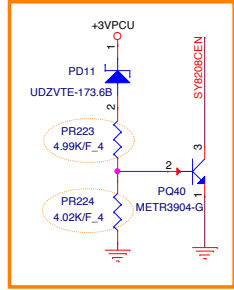

**+5 Volt +/- 5%**  
**Countinue current:4A**  
**Peak current:6A**  
**OCP minimum:7.5A**

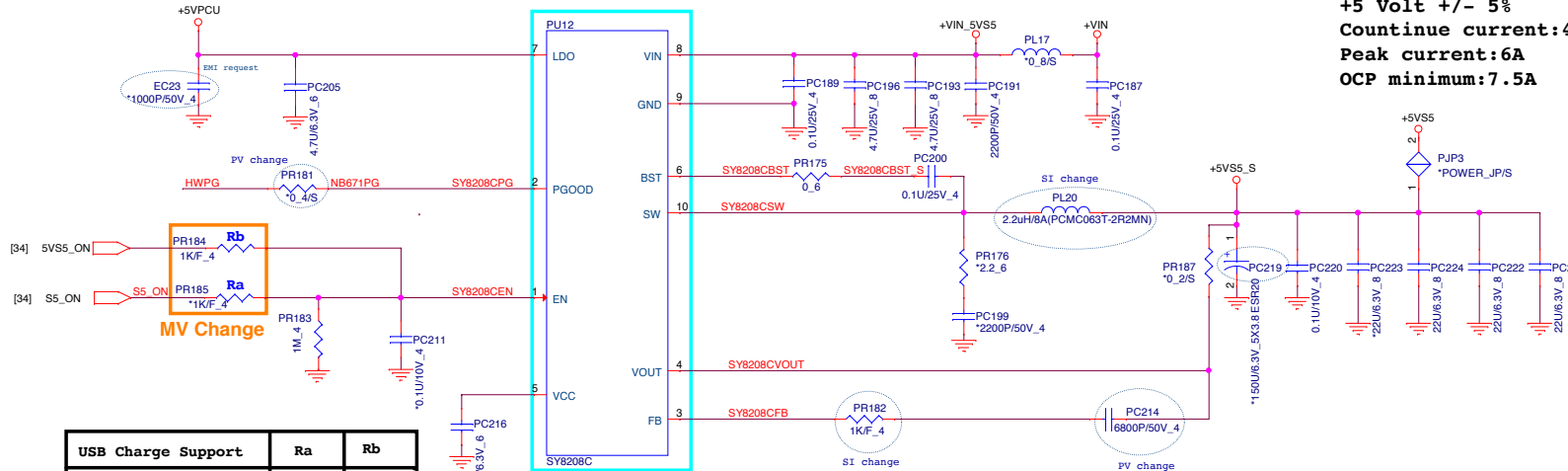

MV Change

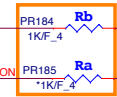

USB Charge Support	Ra	Rb
VINE (No support)	Stuff	NA
ENVY (Support)	NA	Stuff

	<b>PROJECT : R63</b> Quanta Computer Inc.		
	Size Custom	Document Number <b>3/5VPCU(RT8243A)</b>	Rev 1A
	Date: Wednesday, April 02, 2014	Sheet 36 of 44	

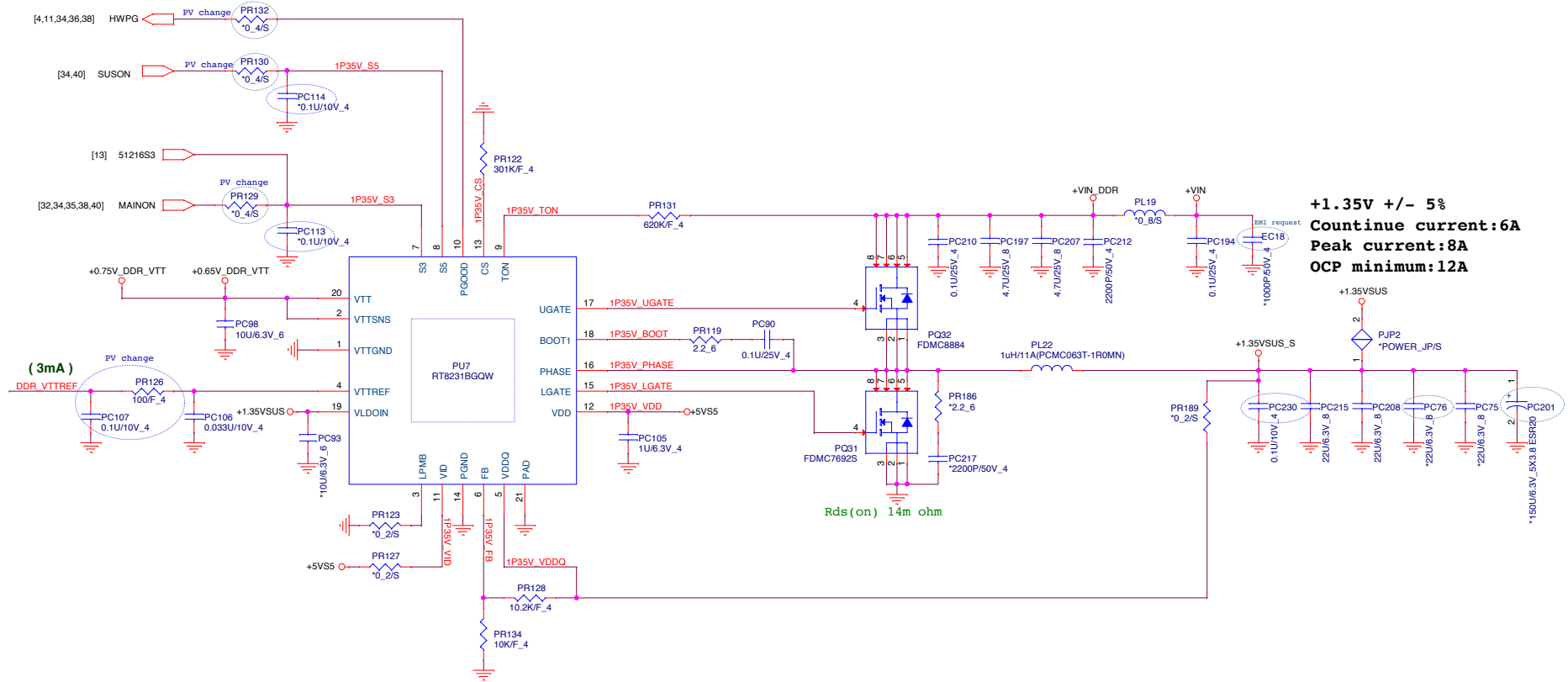

**+1.35V +/- 5%**  
**Countinue current:6A**  
**Peak current:8A**  
**OCP minimum:12A**

Rds(on) 14m ohm

(3mA)  
DDR\_VTTREF

+1.35VSUS [2,4,12,13,29]

	<b>PROJECT : Y02</b>			Rev 1A
	Quanta Computer Inc.			
	Size Custom	Document Number DDR3 (RT8231A)/1.8V55		
Date: Wednesday, April 02, 2014		Sheet 37	of 44	

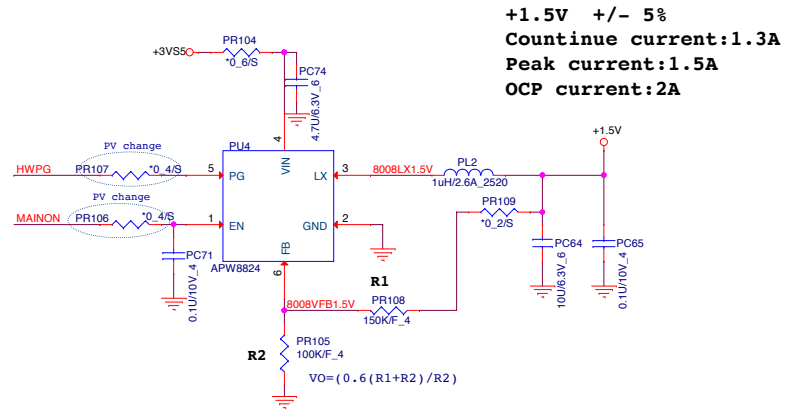
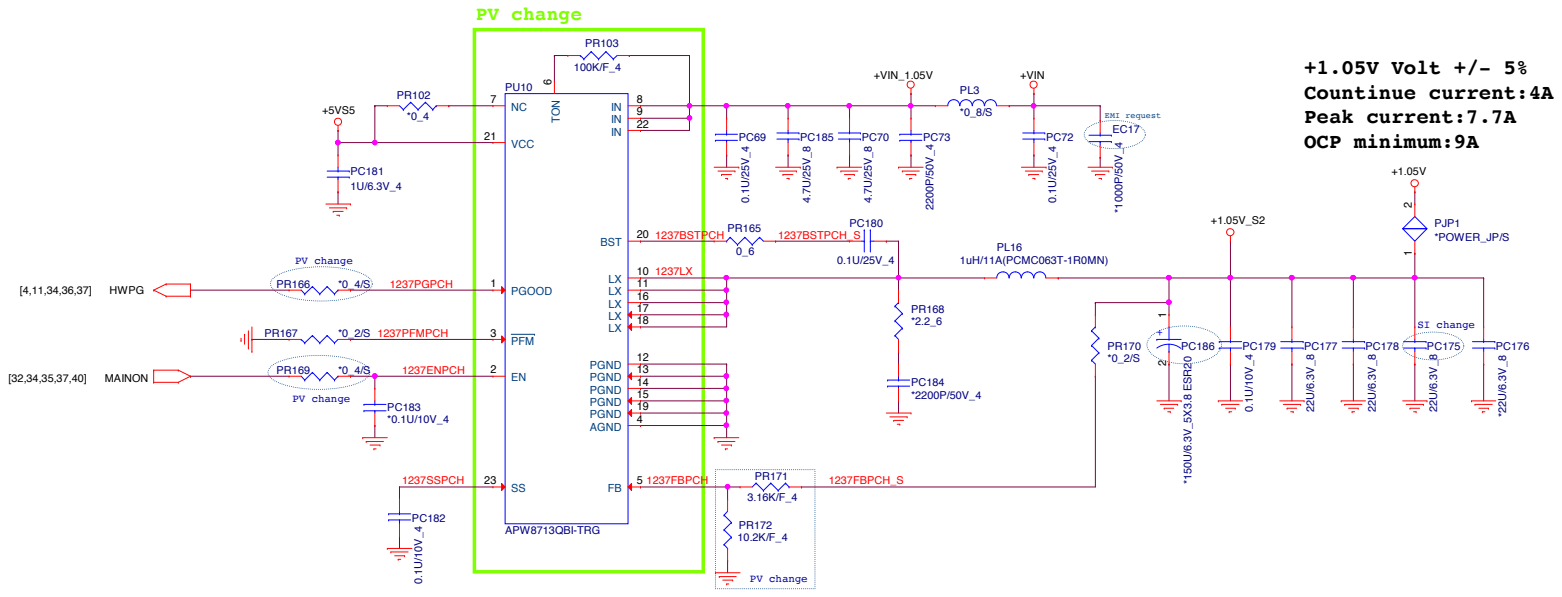

- +VIN [24,26,29,30,35,36,37,39,40,41,42,43]
- +3VSS [6,7,9,10,11,25,29,32,33,36,40,43]
- +5VSS [13,25,29,32,36,37,39,40,41,42,43]

 NB5/RD3	<b>PROJECT : U63</b>		Rev 1A
	Quanta Computer Inc.		
	Size Custom	Document Number <b>+1.1VS5 (RT8228)/2.5V</b>	
Date: Wednesday, April 02, 2014		Sheet 38 of 44	

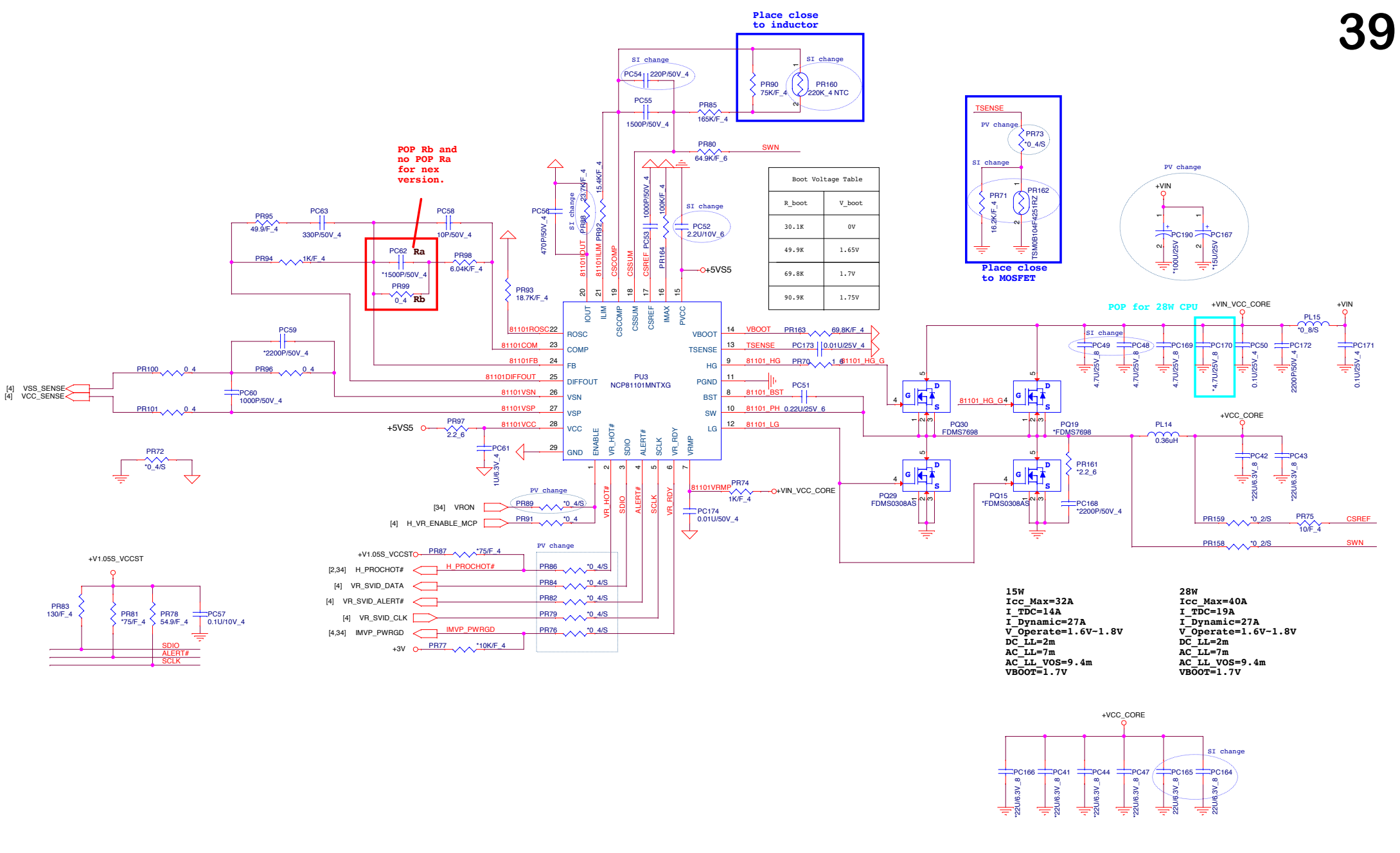

Boot Voltage Table

R_boot	V_boot
30.1K	0V
49.9K	1.65V
69.8K	1.7V
90.9K	1.75V

**15W**  
 I<sub>cc</sub> Max=32A  
 I<sub>TDC</sub>=14A  
 I<sub>Dynamic</sub>=27A  
 V<sub>Operate</sub>=1.6V-1.8V  
 DC<sub>LL</sub>=2m  
 AC<sub>LL</sub>=7m  
 AC<sub>LL</sub> VOS=9.4m  
 VBOOT=1.7V

**28W**  
 I<sub>cc</sub> Max=40A  
 I<sub>TDC</sub>=19A  
 I<sub>Dynamic</sub>=27A  
 V<sub>Operate</sub>=1.6V-1.8V  
 DC<sub>LL</sub>=2m  
 AC<sub>LL</sub>=7m  
 AC<sub>LL</sub> VOS=9.4m  
 VBOOT=1.7V

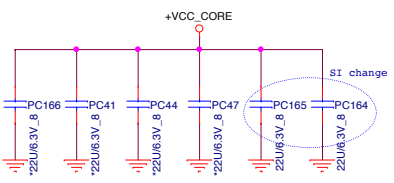

**PROJECT :U83**  
 Quanta Computer Inc.

Size Custom	Document Number CPU Core (NCP81101)ULT	Rev 1A
Date: Wednesday, April 02, 2014   Sheet 39 of 44		

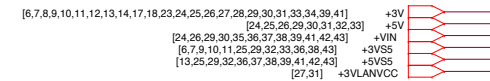
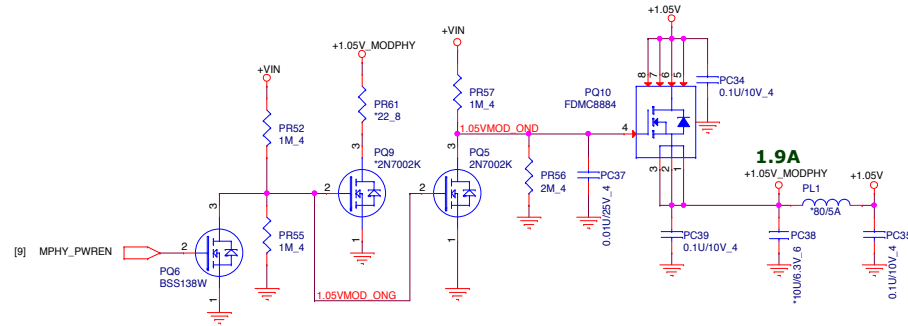
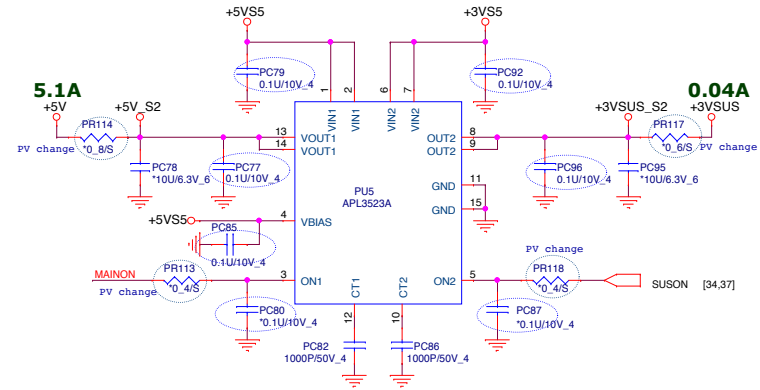
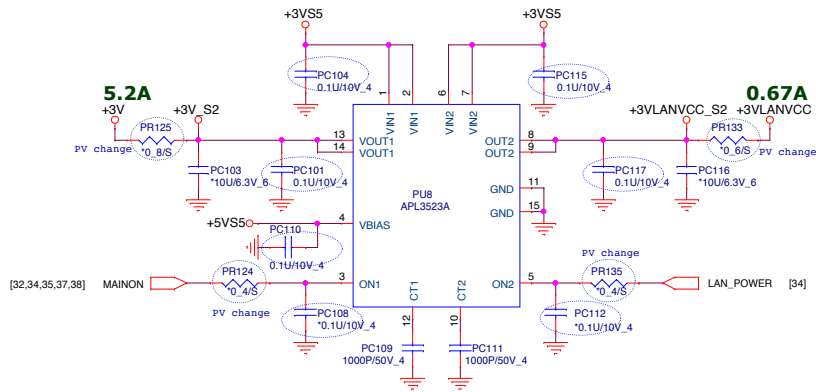



# VGA Core

VGA TYPE	Ra Value	P/N
N15S-GX (25W)	9.53K	CS29532FB10
N15P-GT (35W)	12.4K	CS31242FB13

VGA TYPE	MOSFET
N15S-GX (25W)	1H1L
N15P-GT (35W)	2H2L

VGA TYPE	Ca, Cb
N15S-GX (25W)	No stuff
N15P-GT (35W)	Stuff

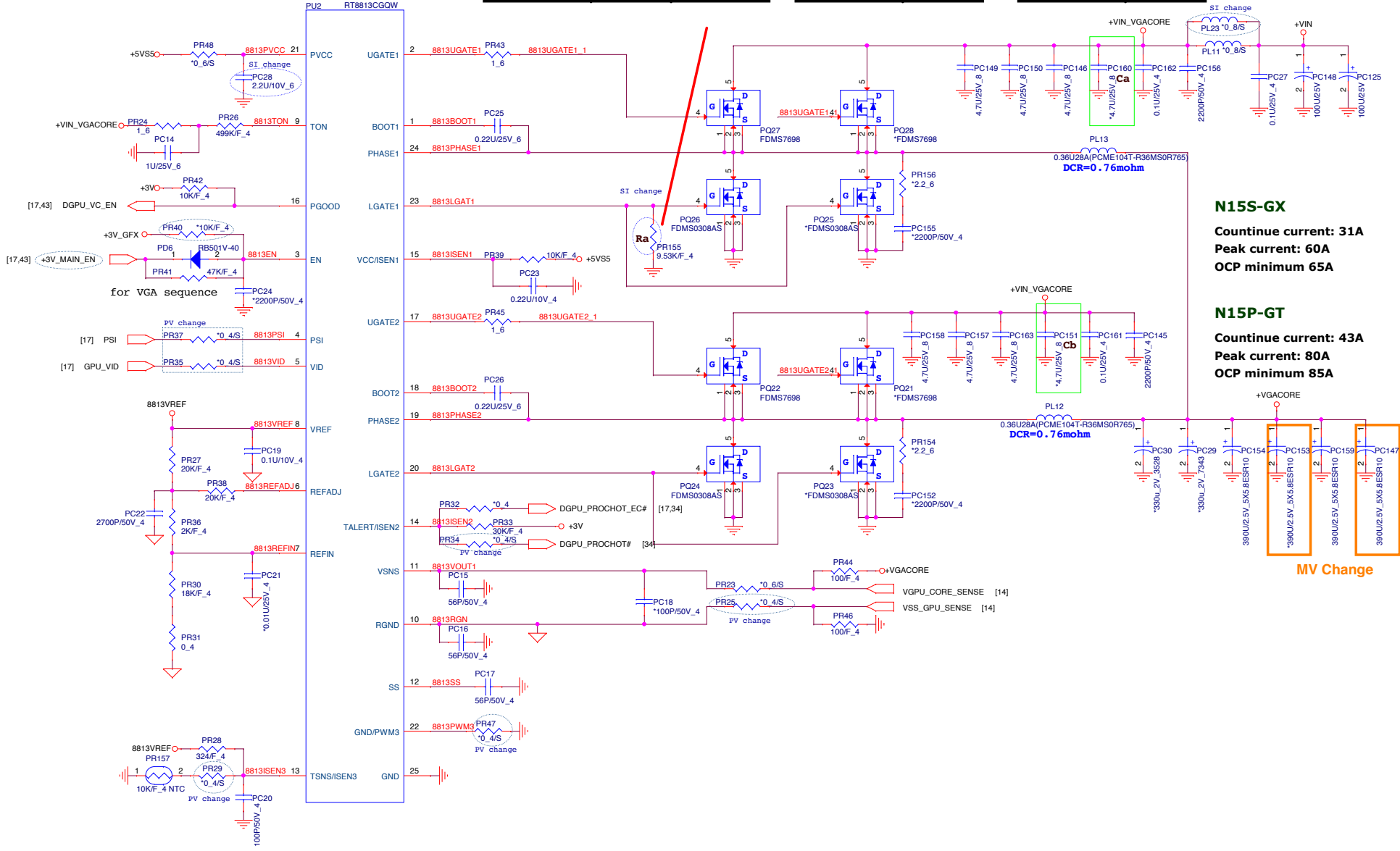

**N15S-GX**  
 Continue current: 31A  
 Peak current: 60A  
 OCP minimum 65A

**N15P-GT**  
 Continue current: 43A  
 Peak current: 80A  
 OCP minimum 85A

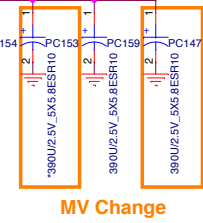

MV Change

**PROJECT :U83**  
 Quanta Computer Inc.

Size Custom	Document Number +VGACORE (RT8813A)	Rev 1A
Date: Wednesday, April 02, 2014	Sheet 41	of 44

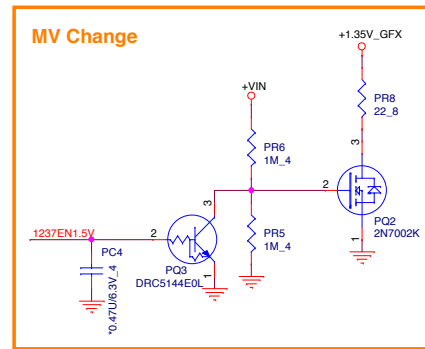
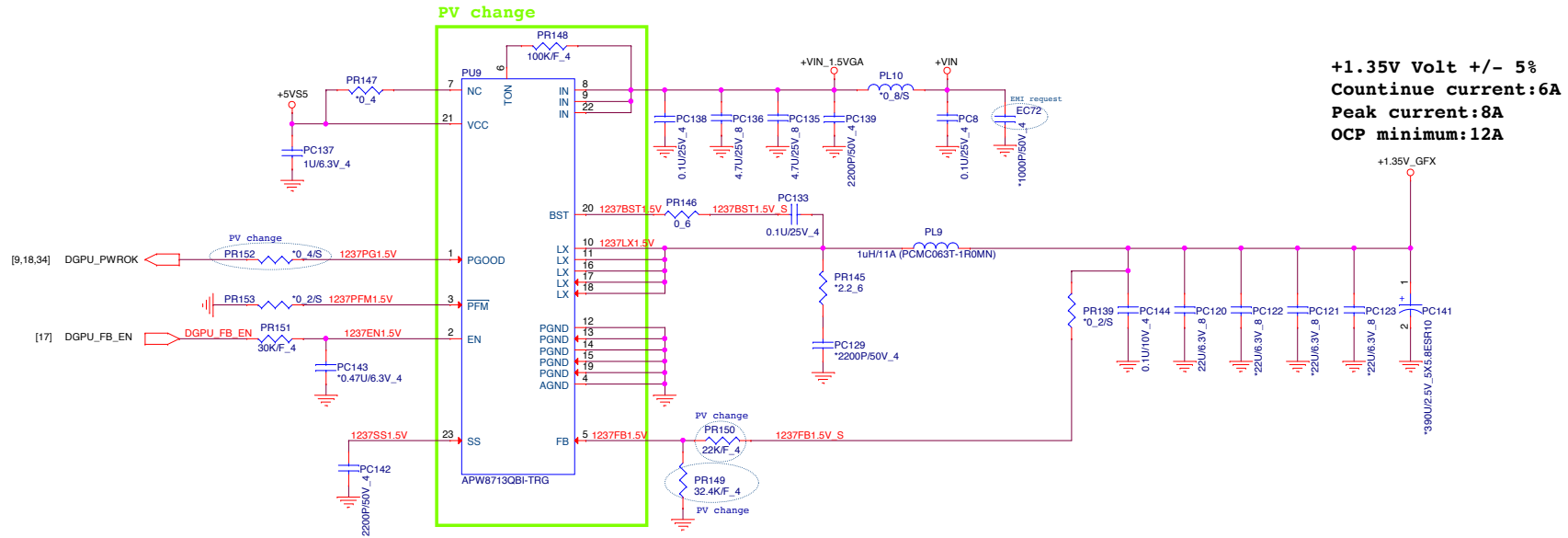

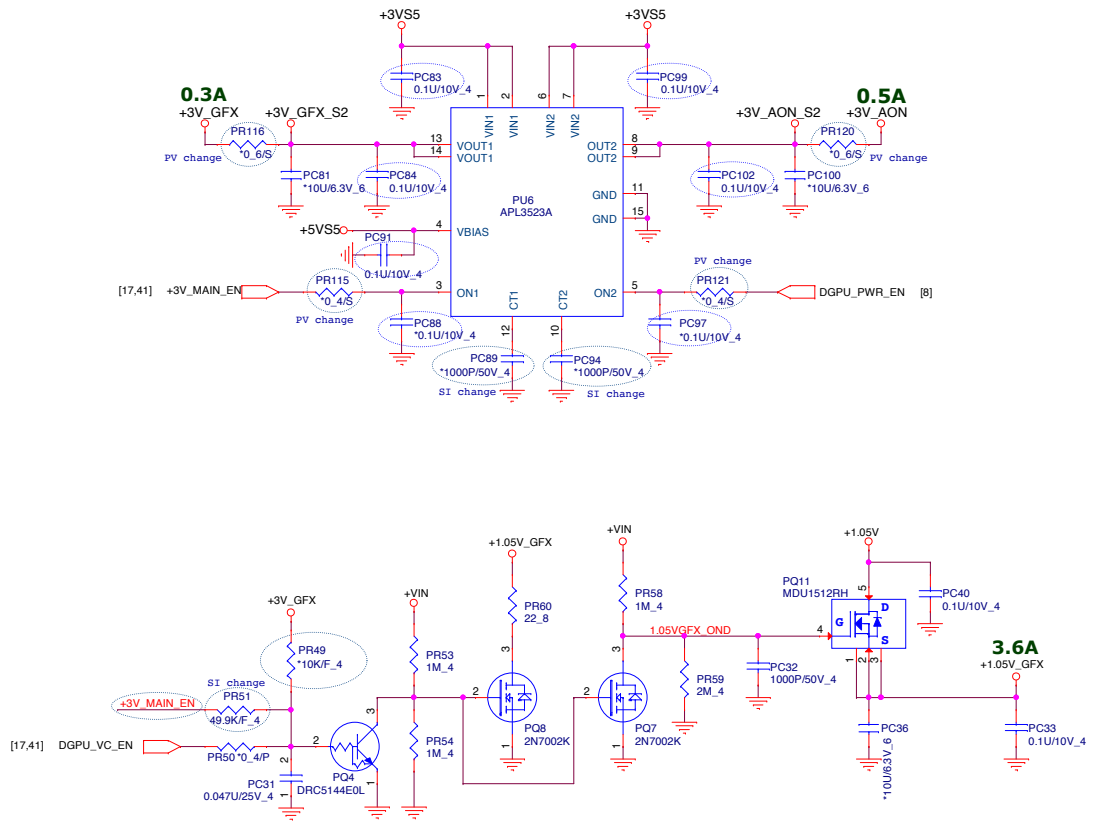

**PROJECT :U83**  
Quanta Computer Inc.

Size Custom	Document Number 1.05V_VGA/3V_VGA	Rev 1A
Date: Wednesday, April 02, 2014		Sheet 43 of 44

Battery Connector	Pavillion	ENVY
14"	DFAD08MR063	DFAD08MR064
15"	DFAD08MR065	DFAD08MR066
17"	<b>DFFC20FR081</b>	<b>DFFC20FR081</b>

USB Charge Support	PR185	PR184
Pavillion	Stuff	NA
ENVY (USB charge)	NA	Stuff

UMA	Disable Page 41 、 42 、 43 ,but keep below location
Page 41	PC161 、 PC162
Page 42	PC138 、 PC144 、 PC4 、 PC148
Page 43	PC84 、 PC102 、 PC88 、 PC97 、 PC40 、 PC33

Discrete	Location	Part Number
N15S (25W)	PR155	CS29532FB10
	PC151 、 PC160	NA
	PQ21 、 PQ23 、 PQ25 、 PQ28	NA
N15P (35W)	PR155	CS31242FB13
	PC151 、 PC160	Stuff
	PQ21 、 PQ23 、 PQ25 、 PQ28	Stuff

Title		
<Title>		
Size	Document Number	Rev
A	<Doc>	<RevCode>
Date:	Wednesday, April 02, 2014	Sheet 44 of 44