

Page	Title of schematic page	Rev.	Date
01	Page List	1A	
02	Block Diagram	1A	
03	Change List	1A	
04	HSW MCP(DISPLAY/Sideband)	1A	
05	HSW MCP(MEMORY/GND)	1A	
06	HSW MCP(CFG/PwrMGT)	1A	
07	HSW MCP(POWER)	1A	
08	HSW PCH(RTC/HDA/SATA)	1A	
09	HSW PCH(PCIE/USB)	1A	
10	HSW PCH(CLK/LPC/SPI/SMB)	1A	
11	HSW PCH(GPIO/LPIO/MISC)	1A	
12	HSW PCH(POWER)	1A	
13	DDR3 DIMM0-STD (5.2H)	1A	
14	DDR3 DIMM1-RSV (5.2H)	1A	
15	HOLE/EMI/KB	1A	
16	WPCE985L & FLASH	1A	
17	LVDS/CAMERA	1A	
18	CARD READER(RTS5227E)	1A	
19	HDMI/THERMAL	1A	
20	USB	1A	
21	LAN (RTL8111GS)	1A	
22	WLAN/KB-BL	1A	
23	HDD/ODD/G-SENSOR/TP/FAN	1A	
24	Audio ALC233-CG	1A	
25	LED/PS/DMIC	1A	
26	POWER +VCC_CORE (NCP81101)	1A	
27	POWER 3VPCU&RVCC5(TPS51427)	1A	
28	POWER 1.35VSUS/VTT_MEM	1A	
29	POWER +1.05V(G5602R41U)	1A	
30	POWER VCC1.5/Thermal	1A	
31	POWER(BAT IN / ADA IN/ UL)	1A	
32	POWER CHARGER (ISL88731C)	1A	
33	POWER VGA_CORE/1.0(RT8812A)	1A	
34	POWER VGE1CORE/ANT8802X	1A	
35	NVIDIA N14 GB2-64 PCIE 1/4	1A	
36	NVIDIA N14 GB2-64 TMD5 2/4	1A	
37	NVIDIA N14 GB2-64 VRAM 3/4	1A	
38	NVIDIA N14 GB2-64 VRAM 4/4	1A	
39	AUDIO Woofers	1A	

Page	Title of schematic page	Rev.	Date
40	IO PORT LIST	1A	
		1A	
		1A	
		1A	

* : No mount
L@ : For LVDS output
D@ : For eDP output
E@ : For DIS GFX
I@ : For UMA

HKC Haswell ULT BLOCK DIAGRAM

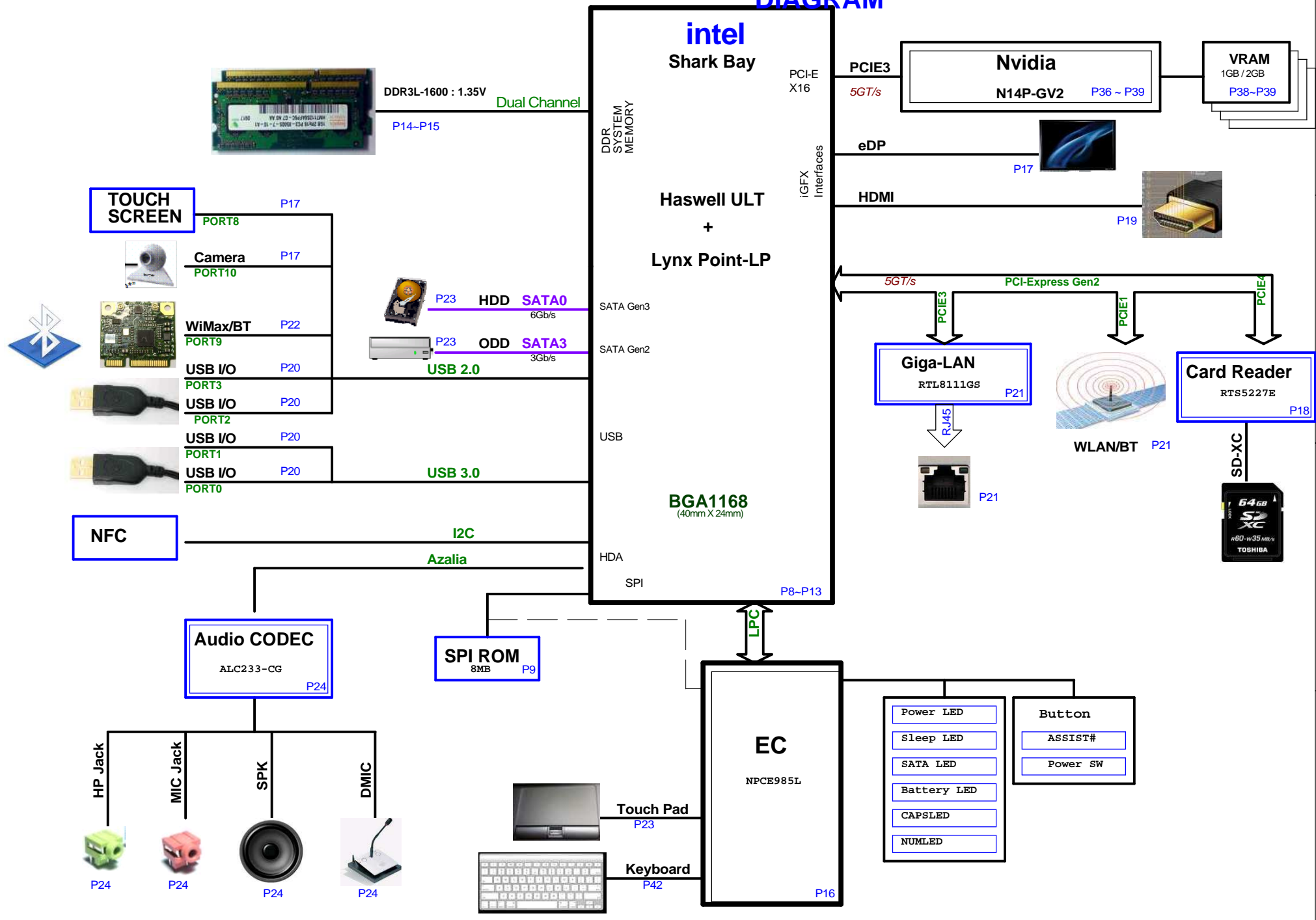

D

D

C

C

B

B

A

A

		Quanta Computer Inc.
PROJECT :HKC		
Size	Document Number	Rev
	Change List	1A
Date: Thursday, January 24, 2013	Sheet 3 of 40	

Haswell ULT (DISPLAY)

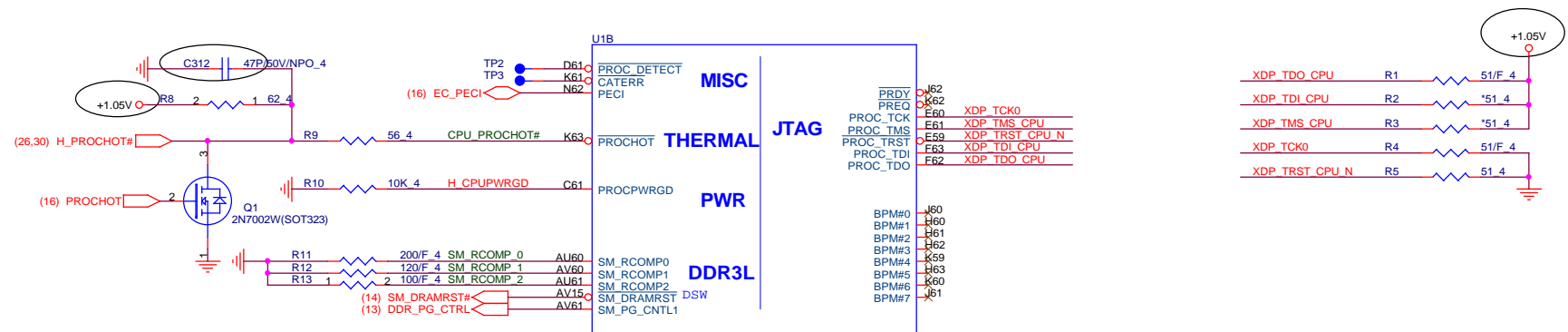
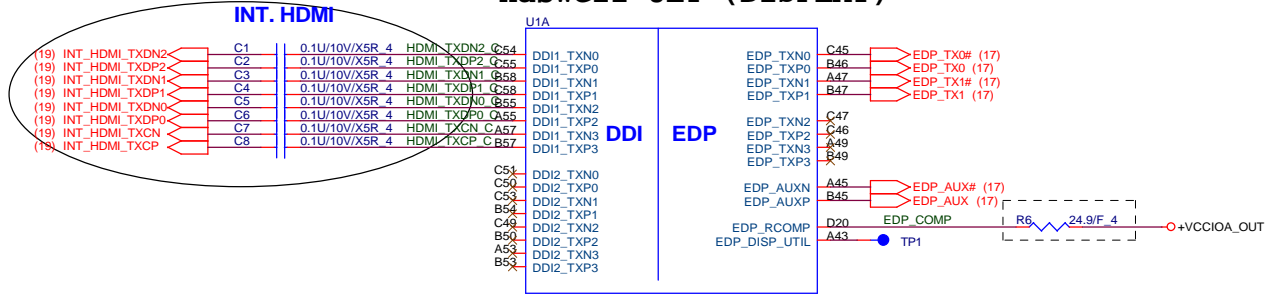

Quanta Computer Inc.
PROJECT : HKC

Size	Document Number	Rev
		1A
HSW MCP(Display/eDP)		
Date:	Thursday, January 31, 2013	Sheet 4 of 40

1. Level 1 Environment-related Substances Should Never be Used.
2. Recycled Resin and Coated Wire should be procured from Green Partners.

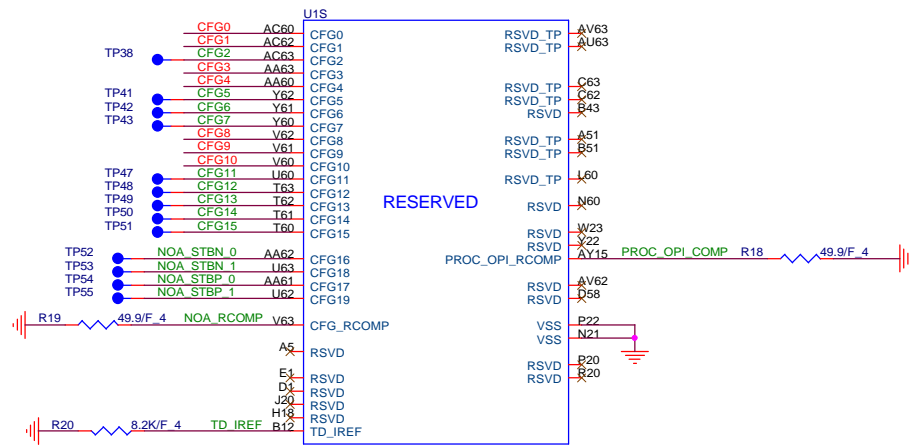

Processor Strapping

	1	0	
CFG0 EAR-STALL/NOT STALL RESET SEQUENCE AFTER PCU PLL IS LOCKED	(DEFAULT) NORMAL OPERATION; NO STALL	STALL	
CFG1 PCH/ PCH LESS MODE SELECTION	(DEFAULT) NORMAL OPERATION	PCH-LESS MODE	
CFG3 PHYSICAL_DEBUG_ENABLED (DFX PRIVACY)	DISABLED	ENABLED SET DFX ENABLED BIT IN DEBUG INTERFACE MSR	
CFG4 DISPLAY PORT PRESENCE STRAP	DISABLED NO PHYSICAL DISPLAY PORT ATTACHED TO EMBEDDED DISPLAY PORT	ENABLED; NOA WILL BE AVAILABLE REGARDLESS OF THE LOCKING OF THE UNIT	
CFG 8 ALLOW THE USE OF NOA ON LOCKED UNITS	DISABLED(DEFAULT); IN THIS CASE, NOA WILL BE DISABLED IN LOCKED UNITS AND ENABLED IN UN-LOCKED UNITS	ENABLED AN EXTERNAL DISPLAY PORT DEVICE IS CONNECTED TO THE EMBEDDED DISPLAY PORT	
CFG9 NO SVID PROTOCOL CAPABLE VR CONNECTED	VRS SUPPORTING SVID PROTOCOL ARE PRESENT	NO VR SUPPORTING SVID IS PRESENT. THE CHIP WILL NOT GENERATE (OR RESPOND TO) SVID ACTIVITY	
CFG10 SAFE MODE BOOT	POWER FEATURES ACTIVATED DURING RESET	POWER FEATURES (ESPECIALLY CLOCK GATINE ARE NOT ACTIVATED	

Quanta Computer Inc.
PROJECT : HKC

Size Document Number HSW MCP(CFG) Rev 1A

Date: Thursday, January 31, 2013 Sheet 6 of 40

1. Level 1 Environment-related Substances Should Never be Used.
2. Recycled Resin and Coated Wire should be procured from Green Partners.

Haswell ULT MCP (POWER)

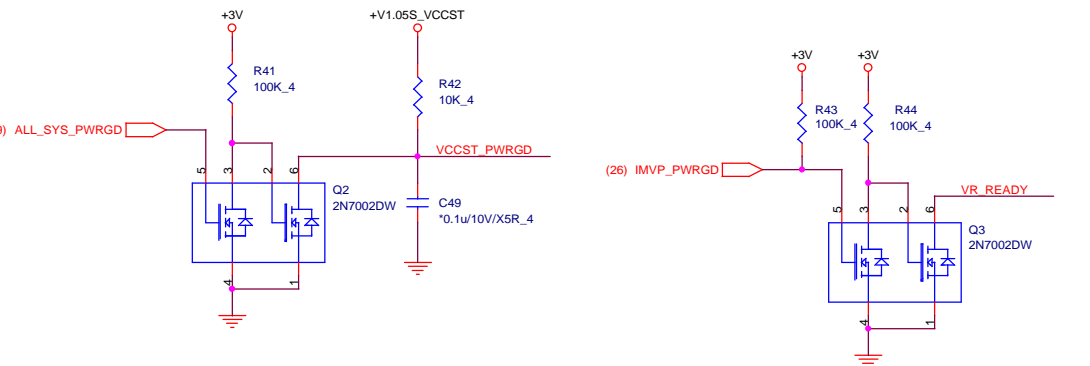
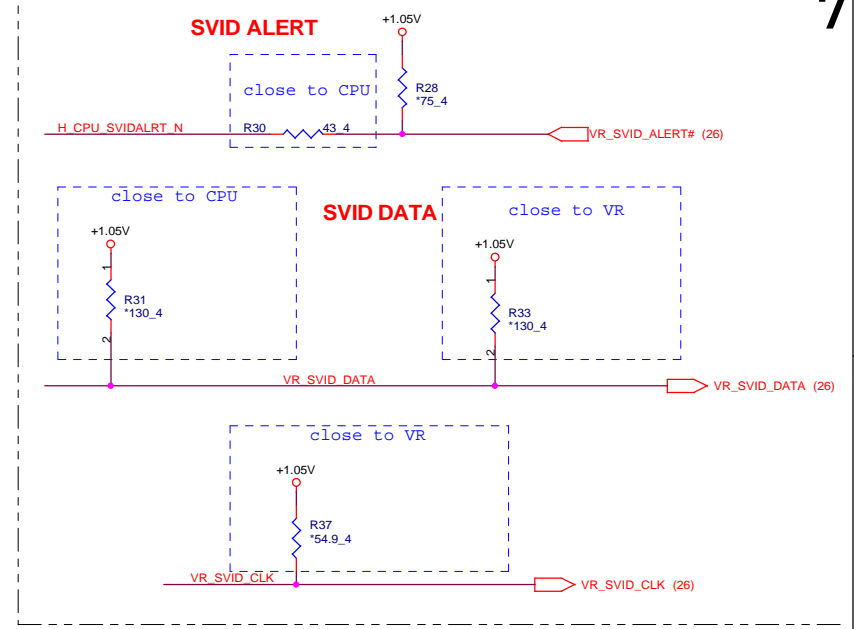
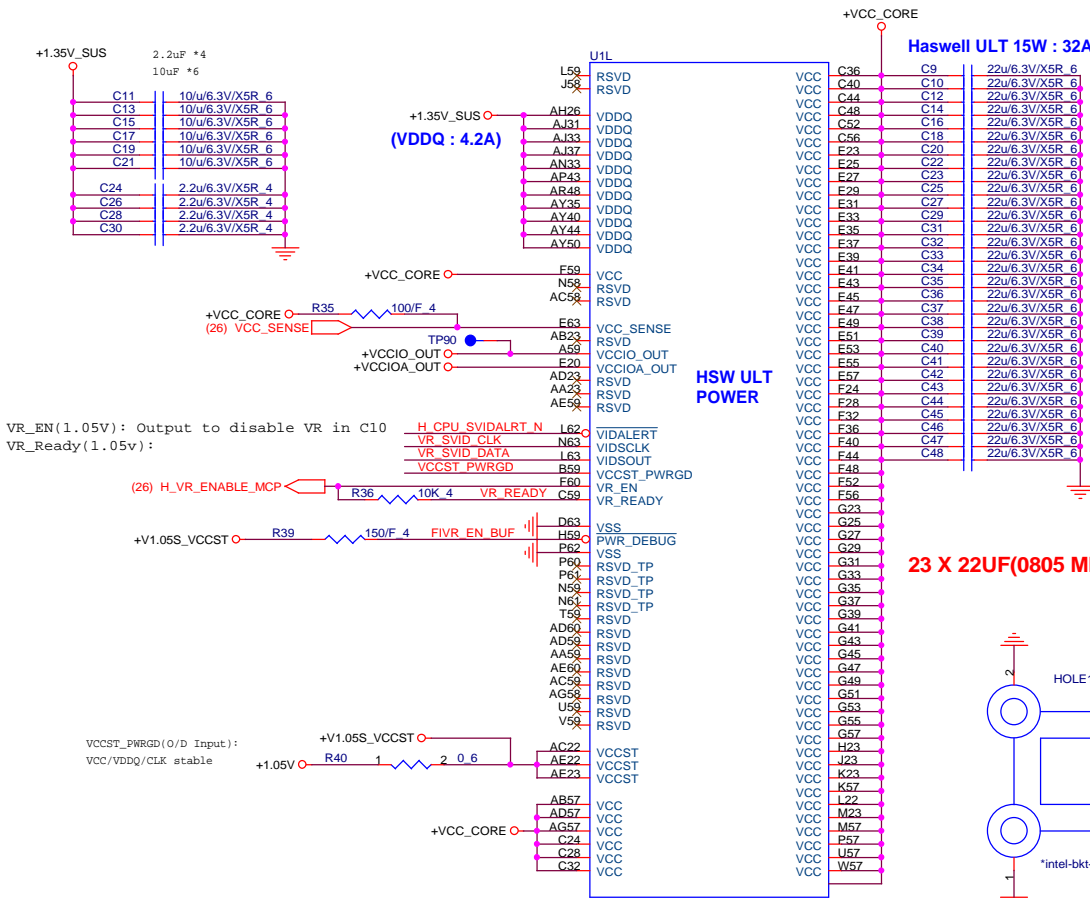

Quanta Computer Inc.
PROJECT : HKC

Size	Document Number	Rev
	HSW MCP(Power)	1A

Date: Thursday, January 31, 2013 Sheet 7 of 40

1. Level 1 Environment-related Substances Should Never be Used.
2. Recycled Resin and Coated Wire should be procured from Green Partners.

Haswell ULT (RTC, HDA, JTAG, SATA)

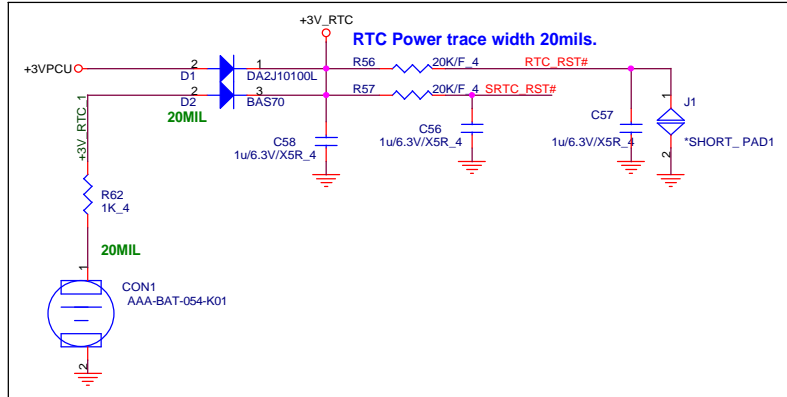
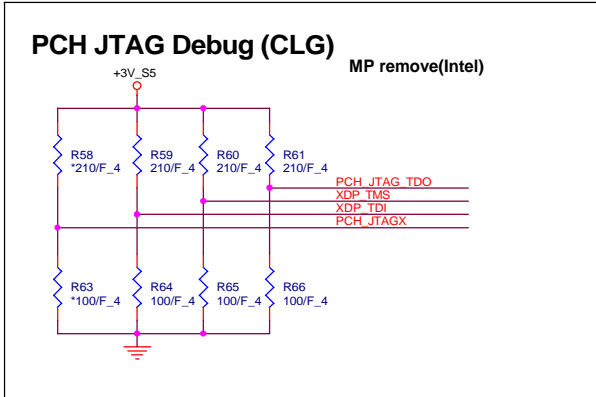
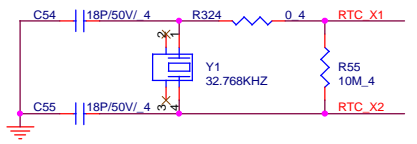
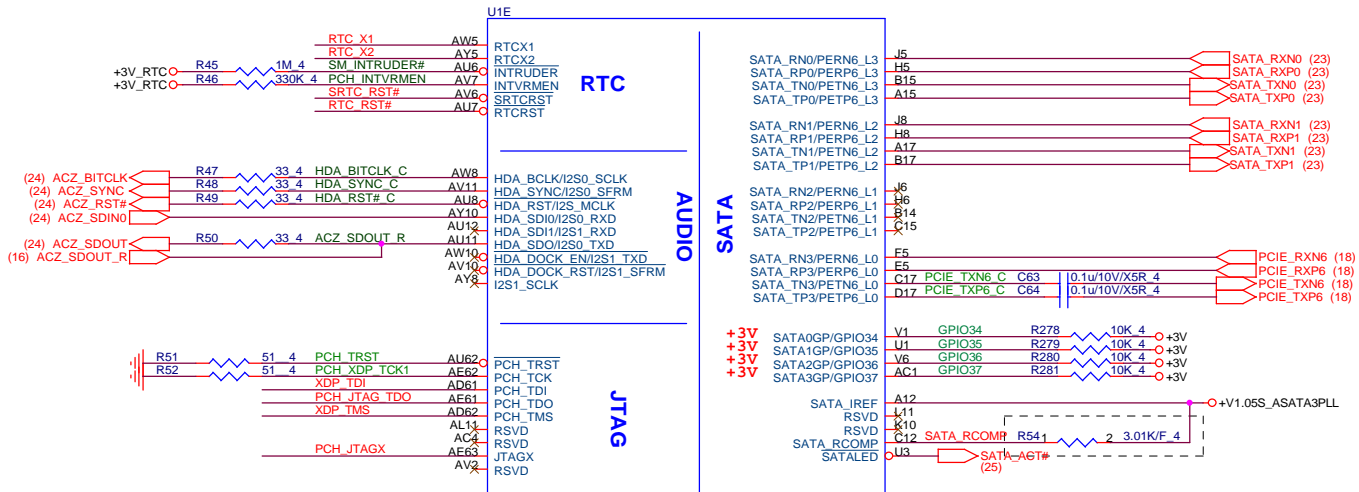

PCH Strap Table

Pin Name	Strap description	Sampled	Configuration	note
SPKR	No reboot mode setting	PWROK	0 = Default (weak pull-down 20K) 1 = Setting to No-Reboot mode	+3V — R67 — *1K 4 —> SPKR (11,24)
HDA_SDO	Flash Descriptor Security Override / Intel ME Debug	PWROK	0 = Security Effect (Int PD) 1 = Can be Override	
INTVRMEN	Integrated 1.05V VRM enable	ALWAYS	Should be always pull-up	

Quanta Computer Inc.
PROJECT : HKC

Size	Document Number	Rev
	HSW PCH(RTC/HDA/SATA)	1A

Date: Friday, February 01, 2013 Sheet 8 of 40

1. Level 1 Environment-related Substances Should Never be Used.
2. Recycled Resin and Coated Wire should be procured from Green Partners.

Haswell ULT (PCIE,USB)

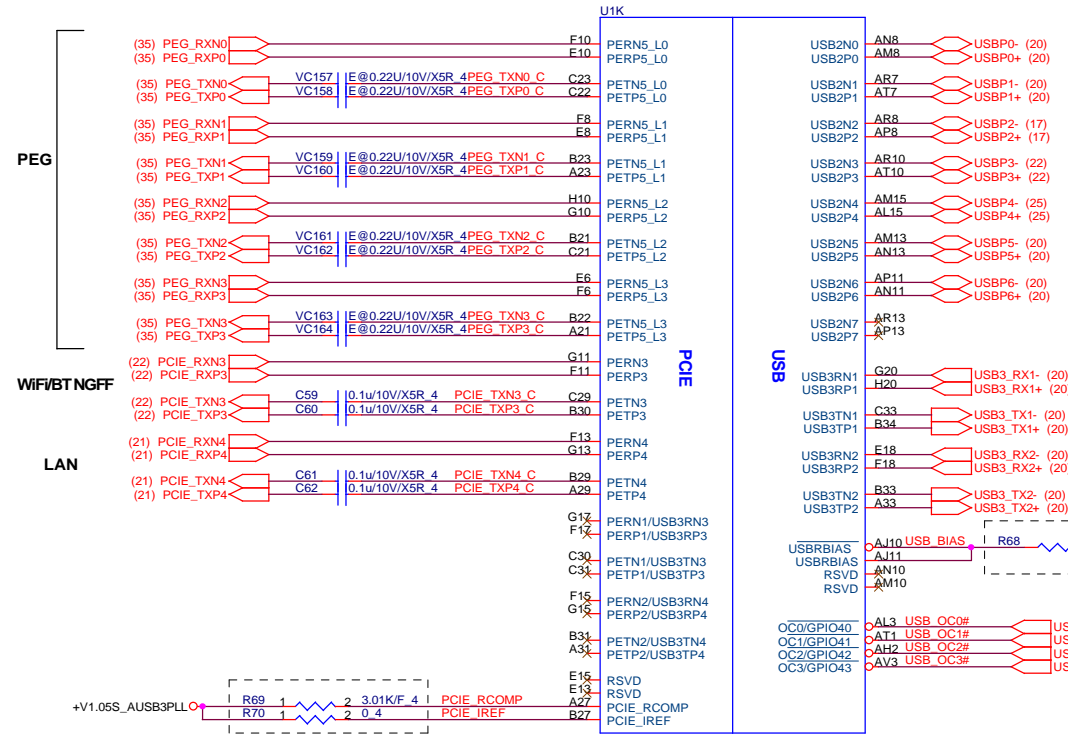

- USB3.0 Port 1 with Charge
- USB3.0 Port 2
- Touch Screen (Full Speed)
- BT NGFF (Full Speed)
- CAMERA
- USB2.0 Port 1
- USB2.0 Port 2
- USB3.0 Port 1
- USB3.0 Port 2

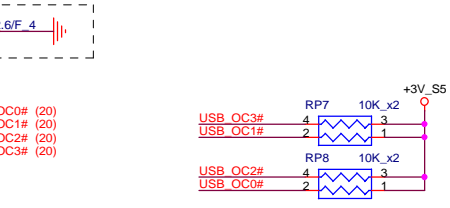

Haswell ULT (SYSTEM POWER MANAGEMENT)

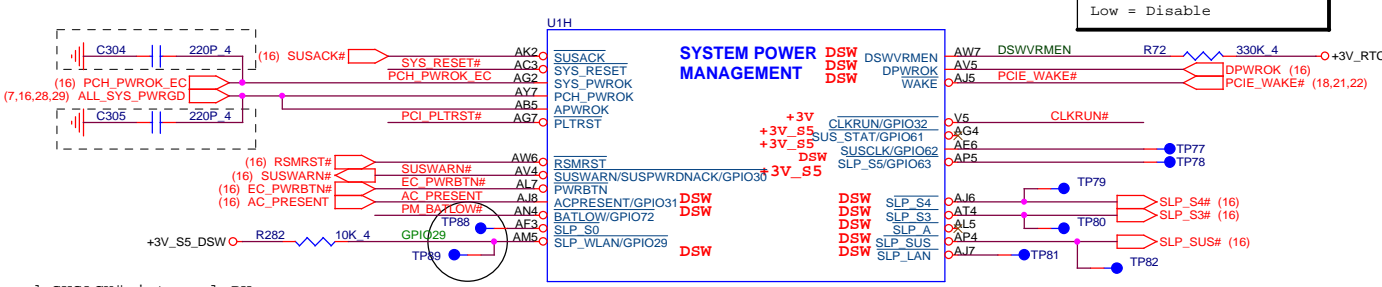

On Die DSW VR Enable
 High = Enable (Default)
 Low = Disable

PCH Pull-high/low(CLG)

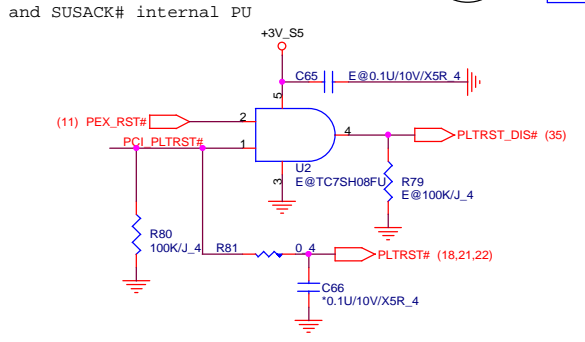
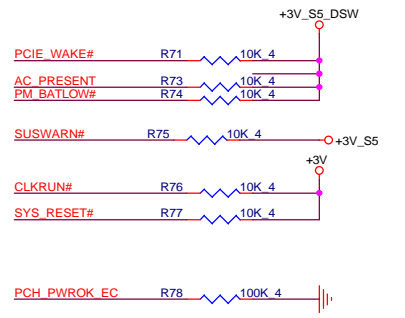

Quanta Computer Inc.
 PROJECT : HKC

Size	Document Number	Rev
	HSW PCH(PCIE/USB)	1A

Date: Thursday, January 31, 2013 Sheet 9 of 40

1. Level 1 Environment-related Substances Should Never be Used.
 2. Recycled Resin and Coated Wire should be procured from Green Partners.

Haswell ULT (CLK)

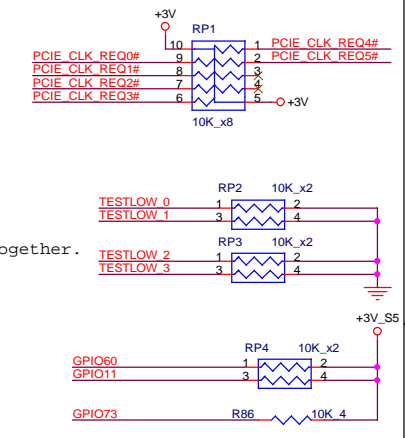
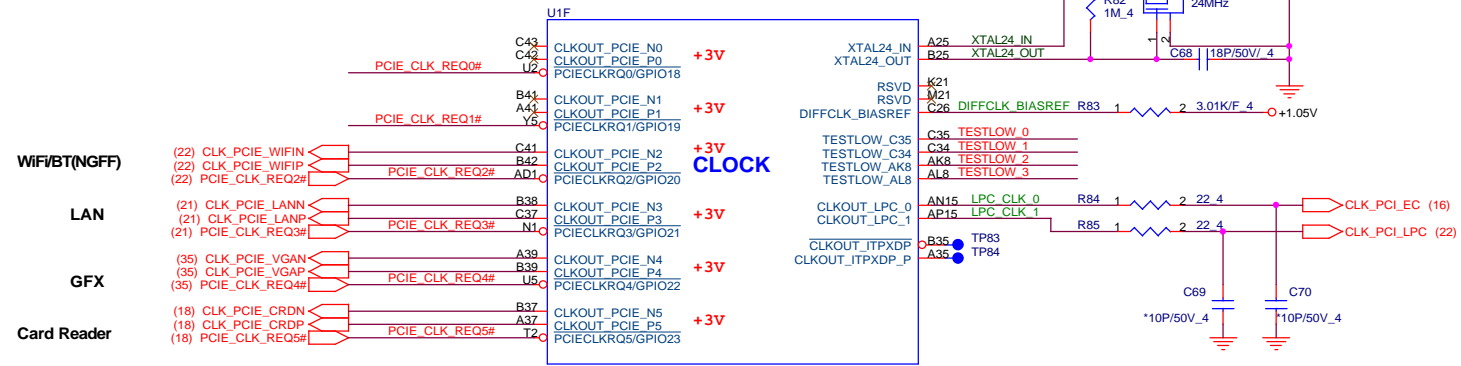

Do not short the testlow pins together.

Haswell ULT (LPC/SPI/SMB/CLINK)

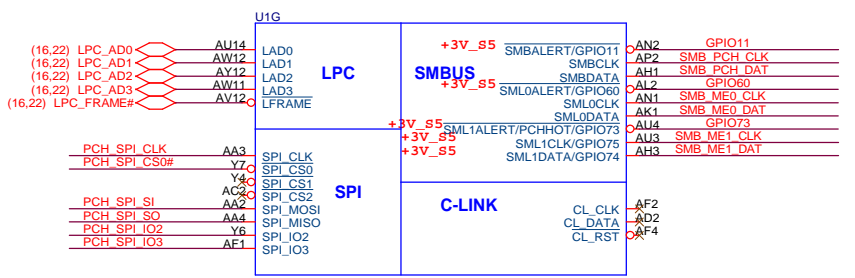

SPD
NFC
EC

SMBus/Pull-up(CLG)

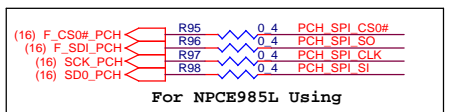
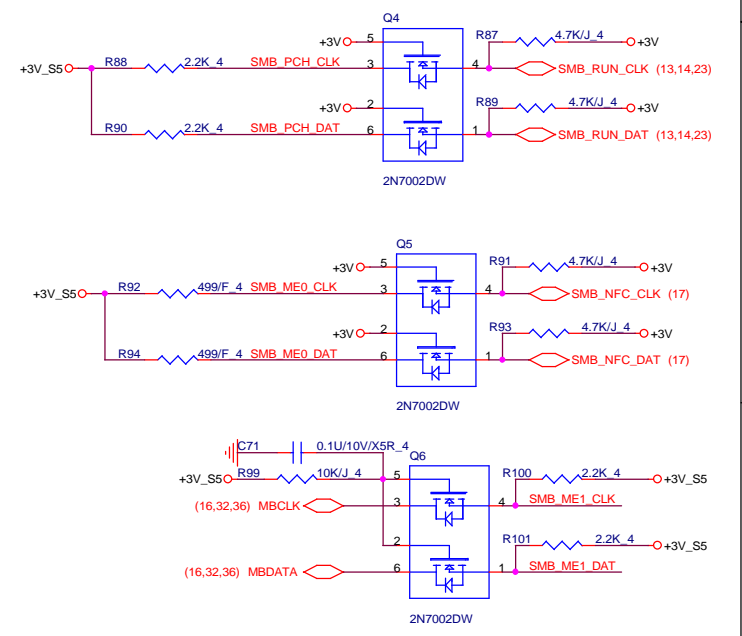

SPI FLASH

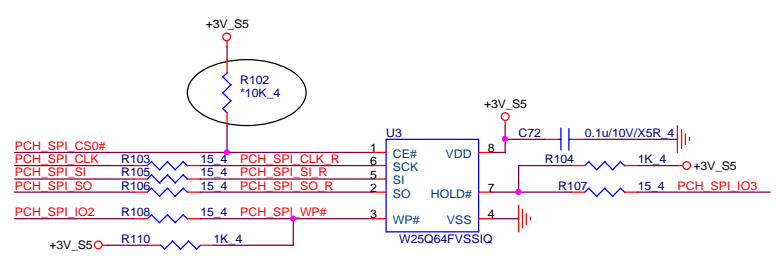

Quanta Computer Inc.
PROJECT : HKC

Size	Document Number	Rev
		1A

1. Level 1 Environment-related Substances Should Never be Used.
2. Recycled Resin and Coated Wire should be procured from Green Partners.

Date: Thursday, January 31, 2013 Sheet 10 of 40

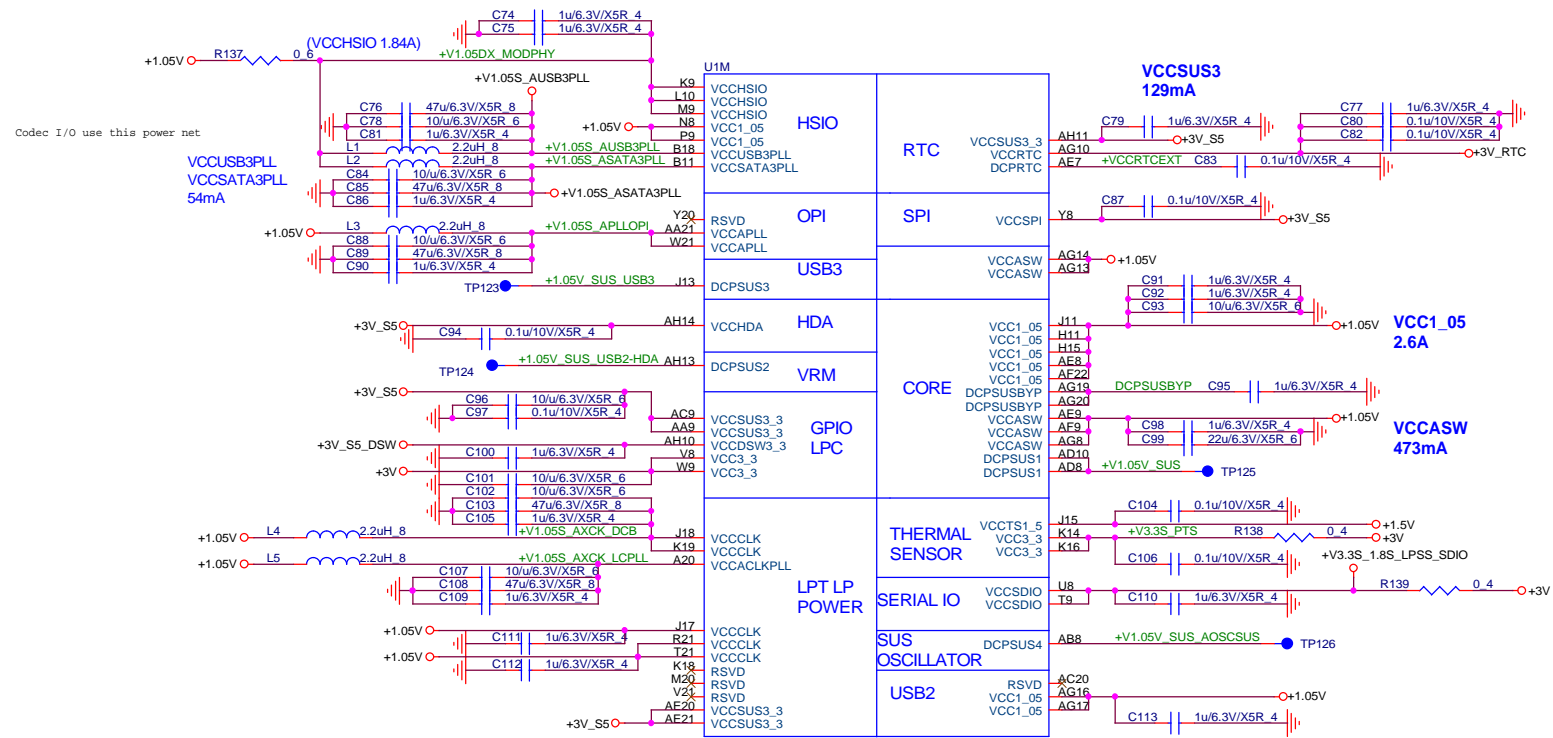

DEEP STANDBY

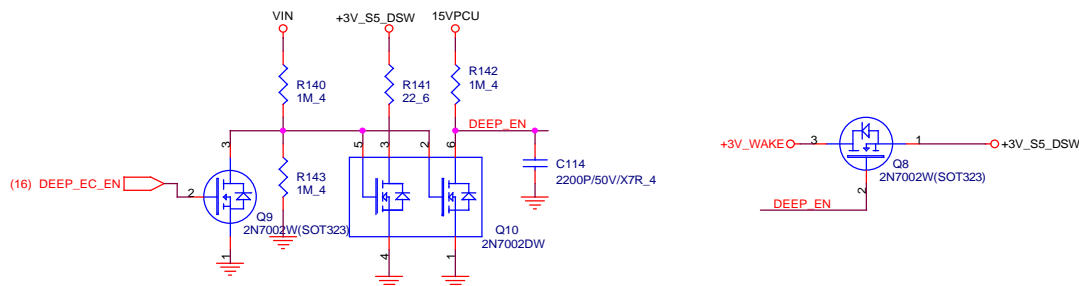

Quanta Computer Inc.
PROJECT : HKC

Size	Document Number	Rev
	HSW PCH(Power)	1A

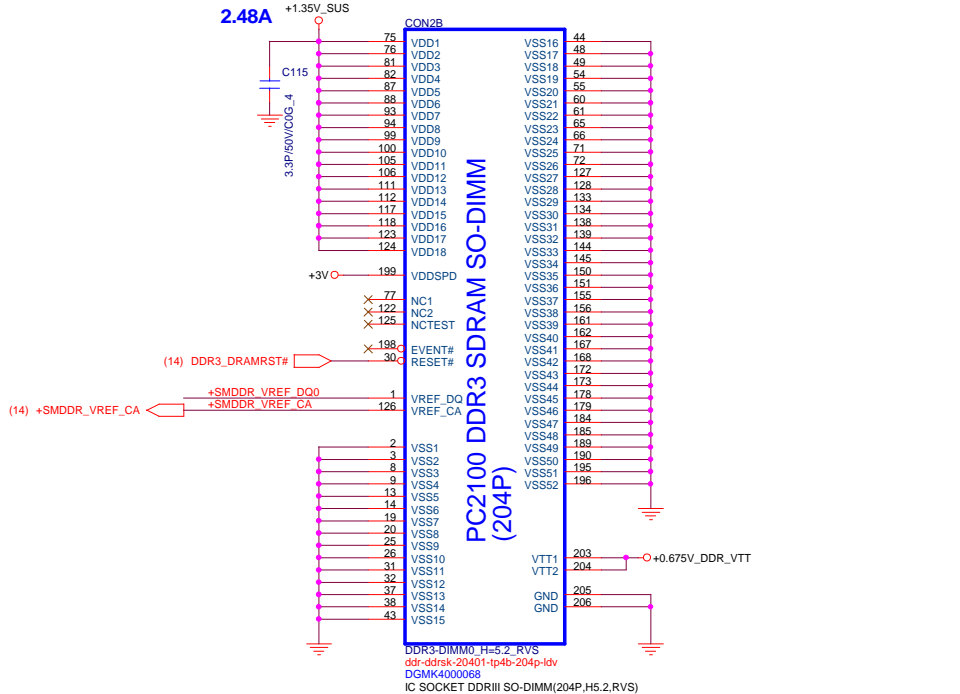
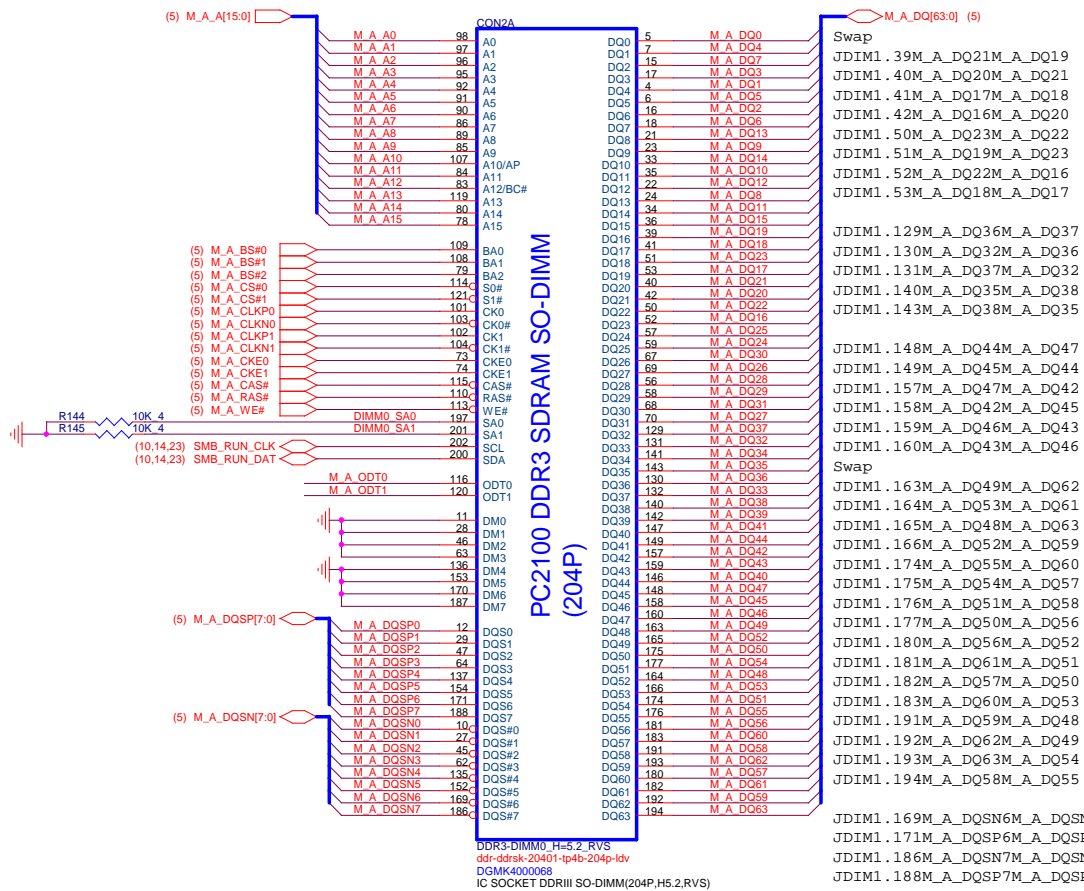

DDR3L SODIMM ODT GENERATION

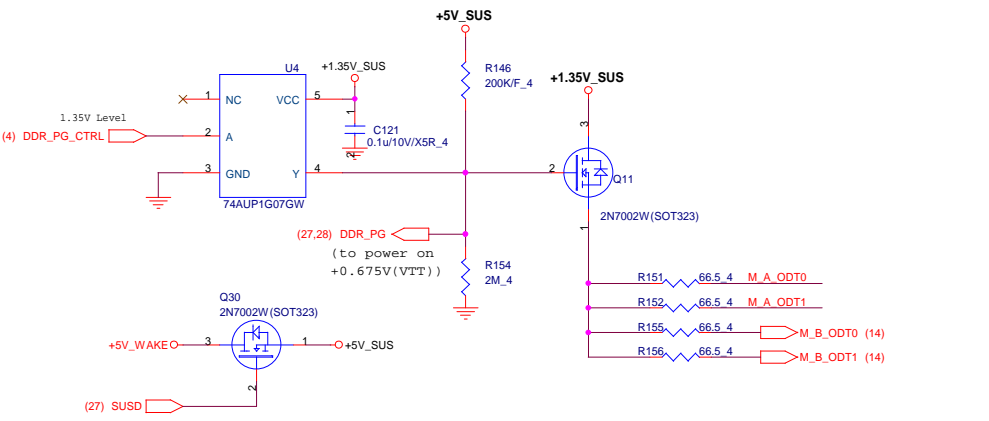

Place these Caps near So-Dimm0.

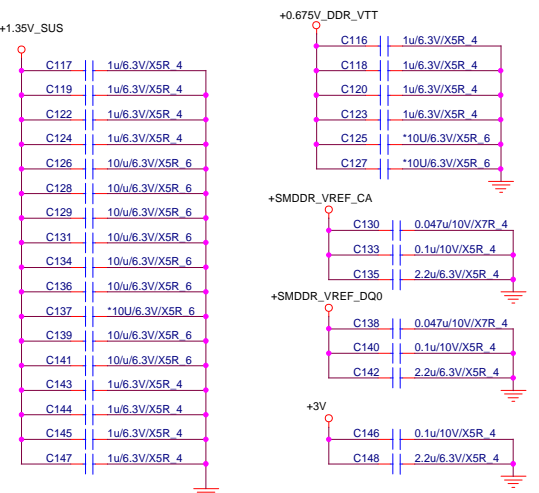

VREF DQ0 M1/M3 Solution

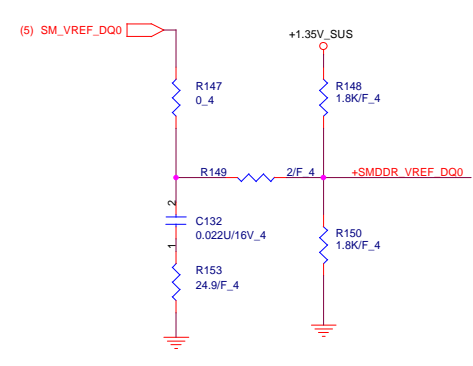

1. Level 1 Environment-related Substances Should Never be Used.
2. Recycled Resin and Coated Wire should be procured from Green Partners.

Quanta Computer Inc.
 PROJECT : HKC

Size Document Number
DDR3 DIMM0 Rev 1A

Date: Thursday, January 24, 2013 Sheet 13 of 40

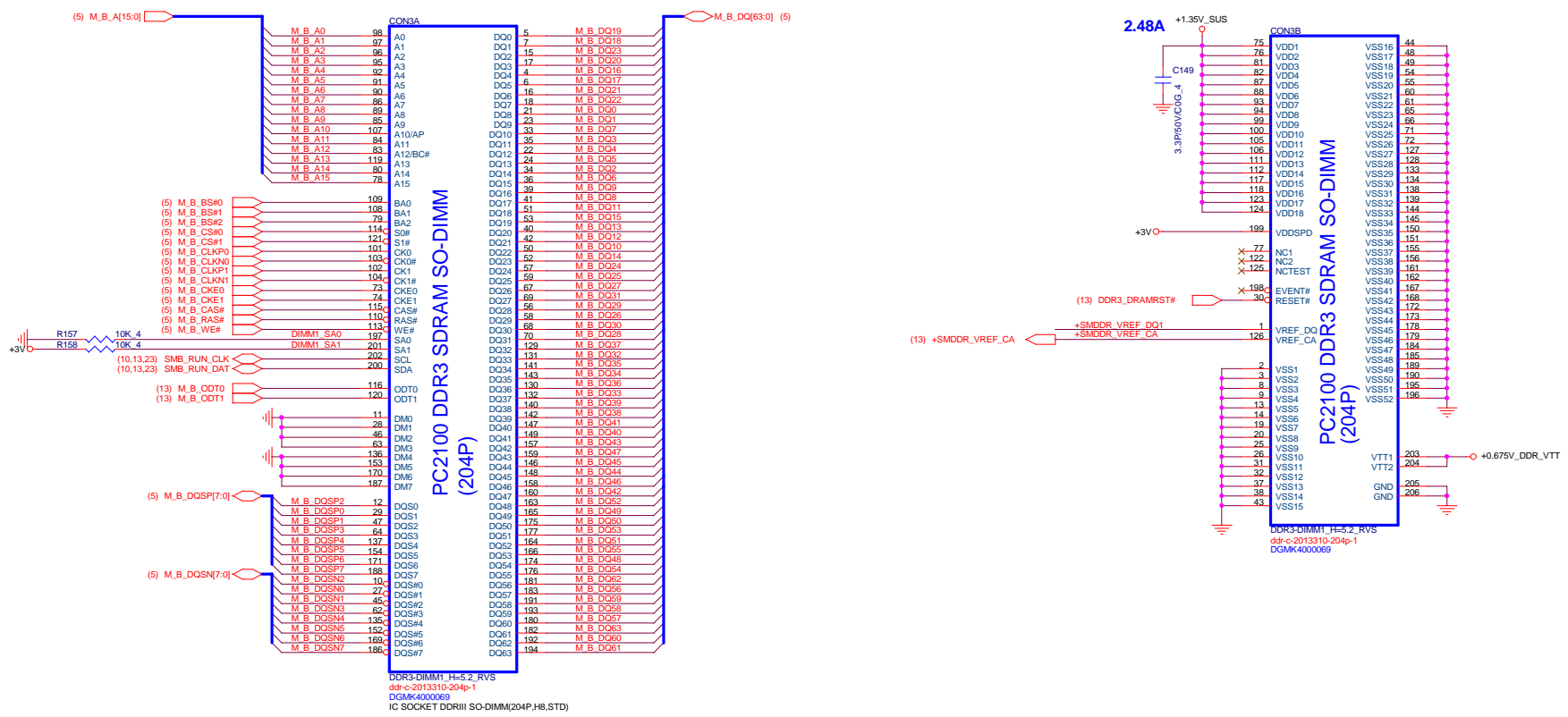

Haswell ULT DRAMRST#

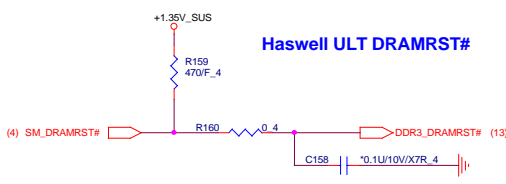

Place these Caps near So-Dimm1

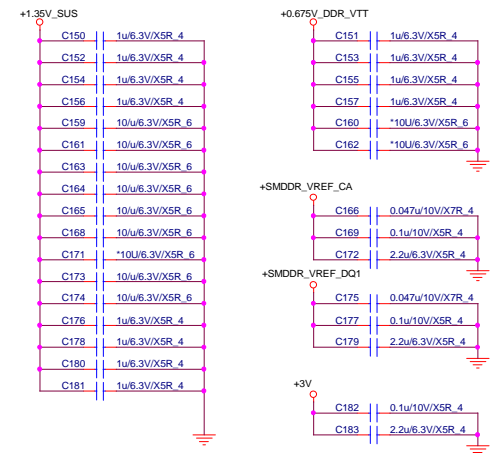

VREF DQ1 Solution

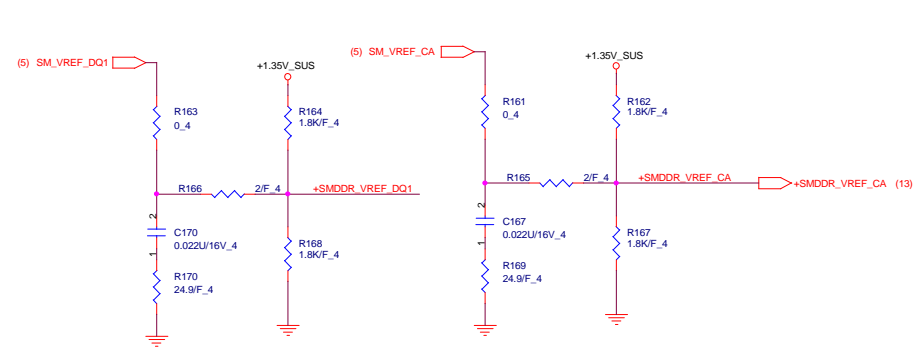

Quanta Computer Inc.
PROJECT : HKC

DDR3 DIMM1

Size: Document Number: Rev: 1A

Date: Thursday, January 24, 2013 Sheet: 14 of 40

1. Level 1 Environment-related Substances Should Never be Used.
2. Recycled Resin and Coated Wire should be procured from Green Partners.

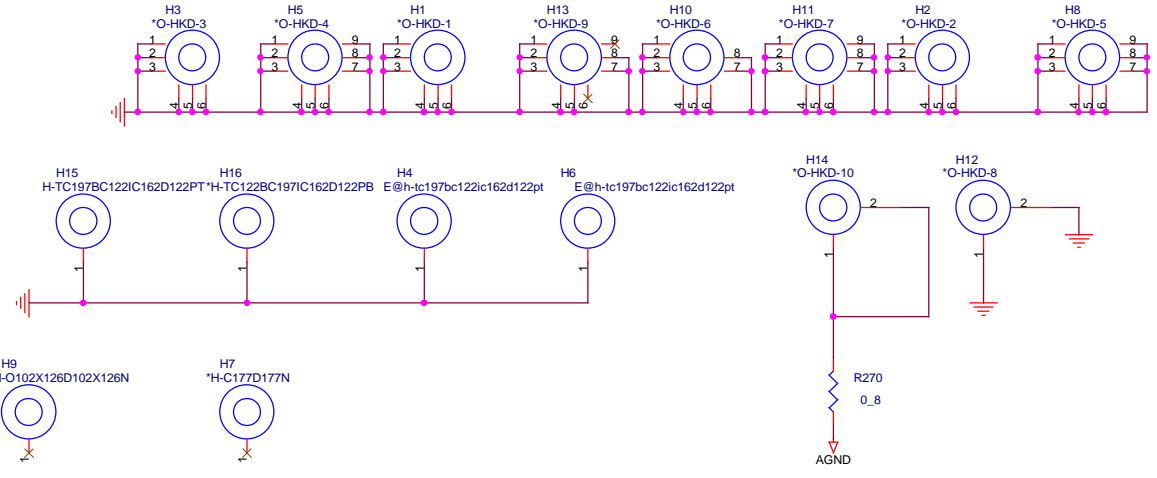

KEY BOARD Connector

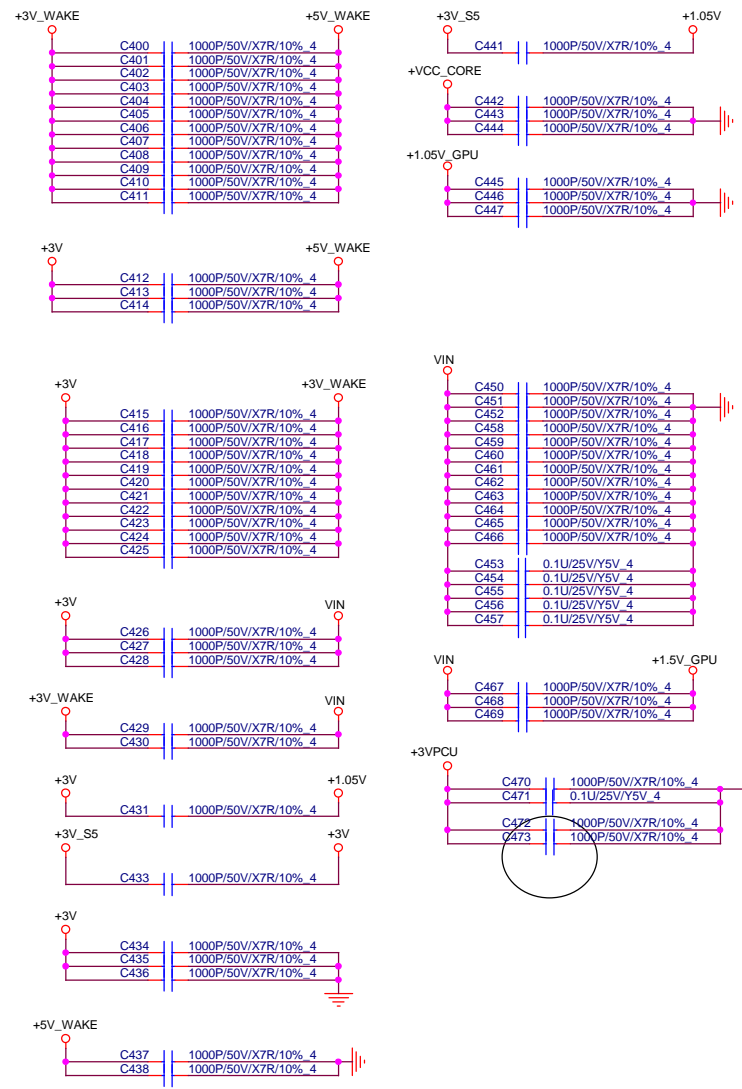
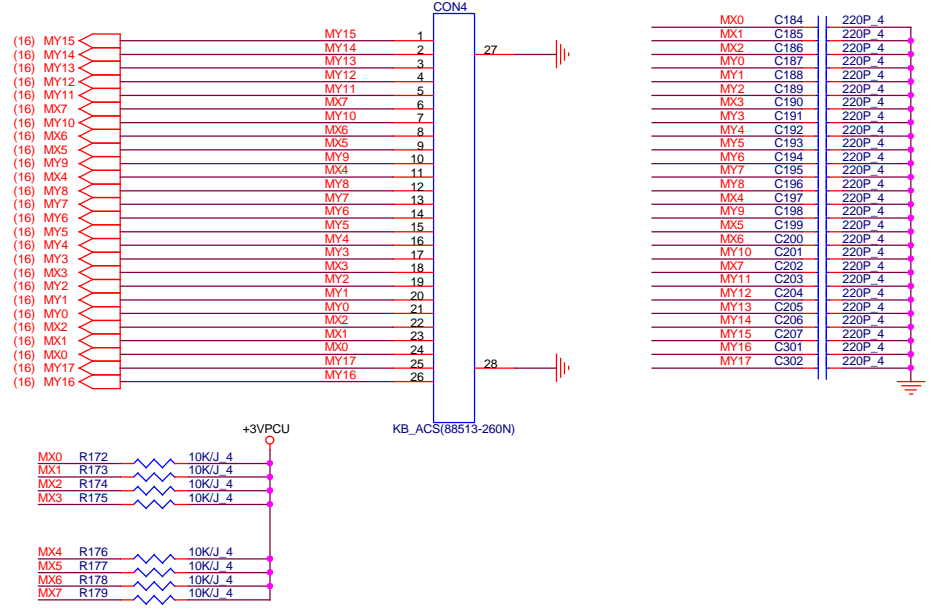

1.Level 1 Environment-related Substances Should Never be Used.
 2.Recycled Resin and Coated Wire should be procured from Green Partners.

Quanta Computer Inc.
PROJECT :HKC

Size	Document Number	Rev
	HOLE/EMI/KB	1A
Date:	Tuesday, February 05, 2013	Sheet 15 of 40

Touch Screen

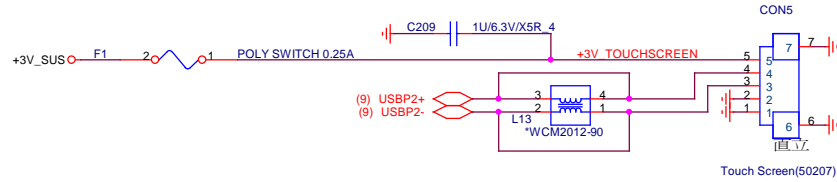
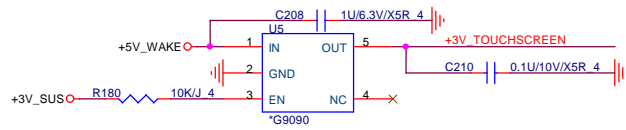

NFC module :
 Vender : Samsung SNC-i20
 Power consumption : Max. 160mW/48mA
 Power Ripple +/- 50mV

FAST, UL/CSA

eDP

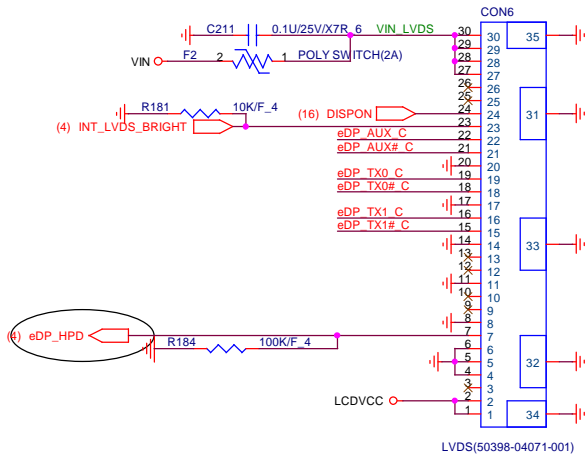

eDP_AUX_C	C212	0.1U/10V/X5R 4	eDP_AUX (4)
eDP_AUX#_C	C213	0.1U/10V/X5R 4	eDP_AUX# (4)
eDP_TX0_C	C214	0.1U/10V/X5R 4	eDP_TX0 (4)
eDP_TX0#_C	C215	0.1U/10V/X5R 4	eDP_TX0# (4)
eDP_TX1_C	C216	0.1U/10V/X5R 4	eDP_TX1 (4)
eDP_TX1#_C	C217	0.1U/10V/X5R 4	eDP_TX1# (4)

Camera HD specification
 Voltage: Max. 3.6V
 Current : Max. 200mA
 OCP: 200mA ~ 300mA

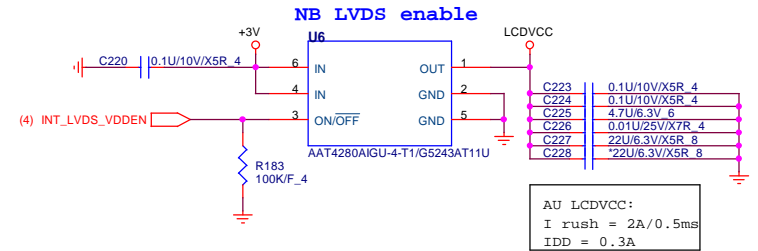

AU LCDVCC:
 I rush = 2A/0.5ms
 IDD = 0.3A

NFC

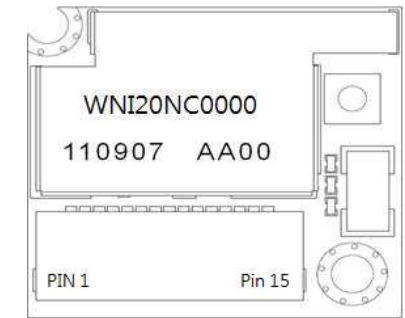
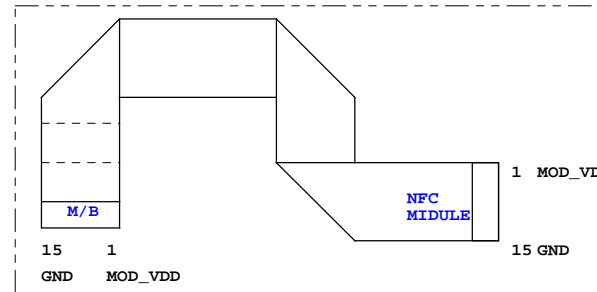
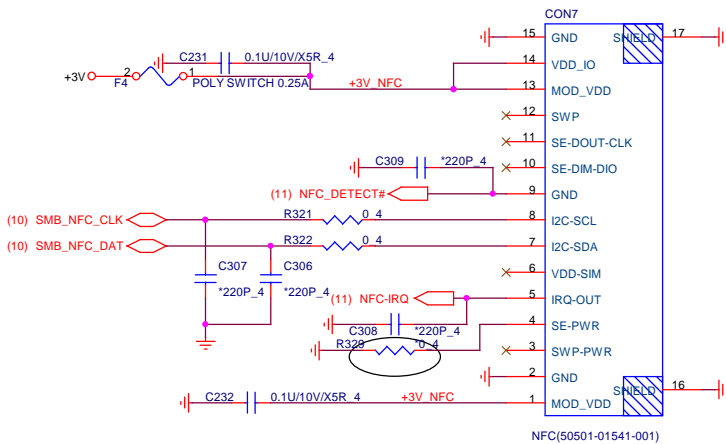

Quanta Computer Inc.
 PROJECT :HKC

Size	Document Number	CRT/LVDS	Rev
			1A

Date: Monday, February 04, 2013 Sheet 17 of 40

1. Level 1 Environment-related Substances Should Never be Used.
 2. Recycled Resin and Coated Wire should be procured from Green Partners.

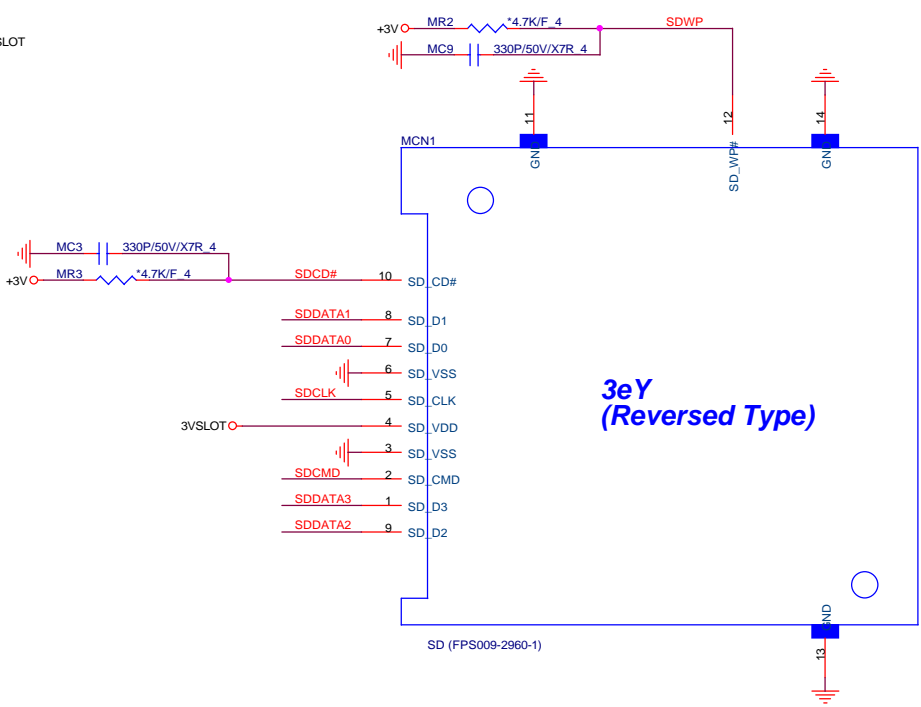
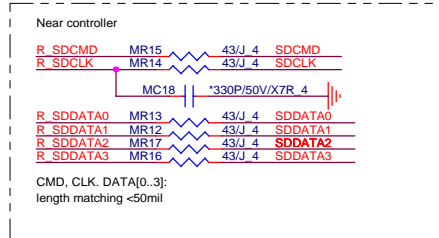
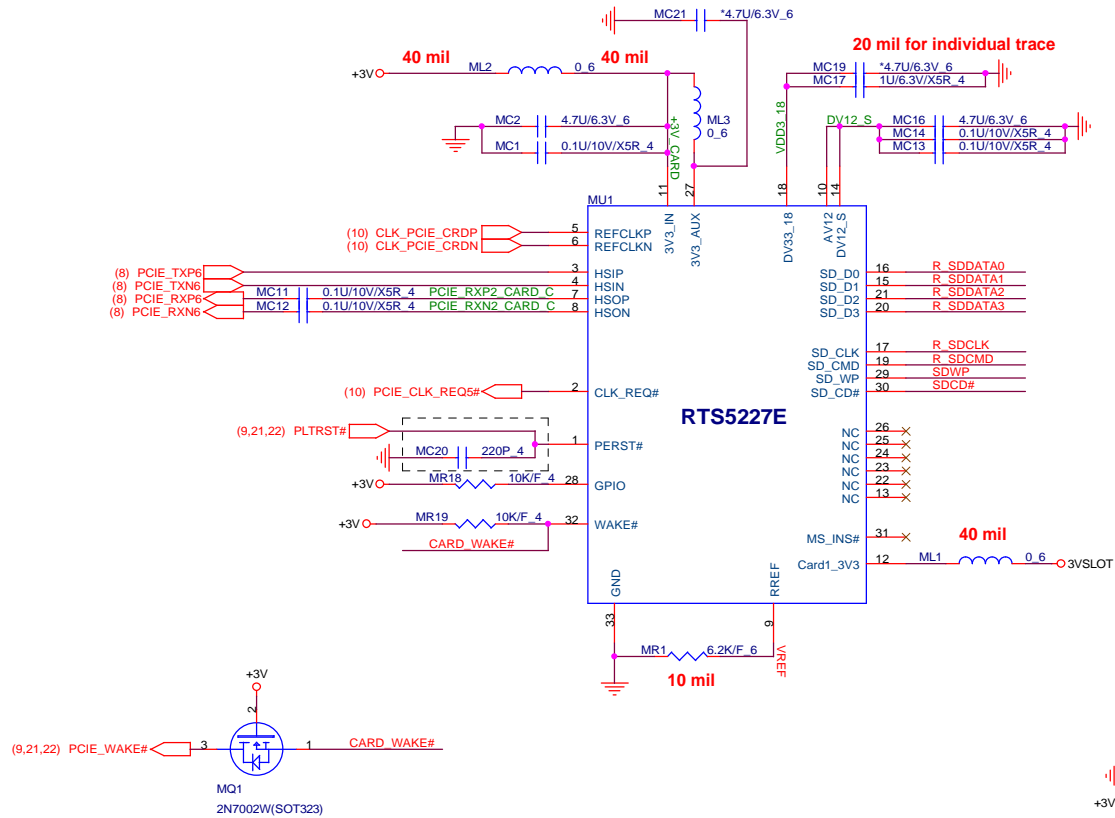

These component need to close to Slot

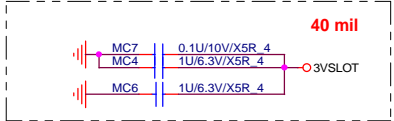

Quanta Computer Inc.
 PROJECT : HKC
CARD
 Size Document Number Rev 1A
 1 Sheet 18 of 40

1. Level 1 Environment-related Substances Should Never be Used.
 2. Recycled Resin and Coated Wire should be procured from Green Partners. Date: Thursday, January 24, 2013

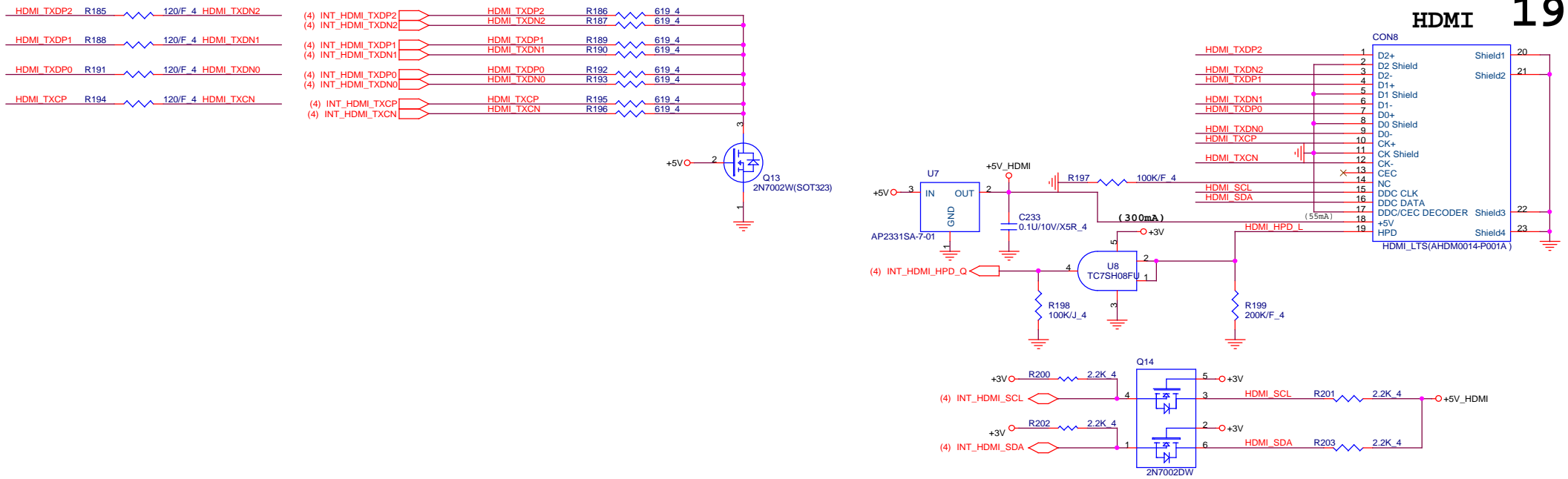

H/W Thermal Protect

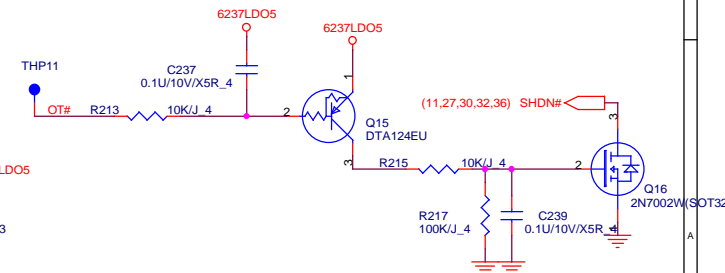
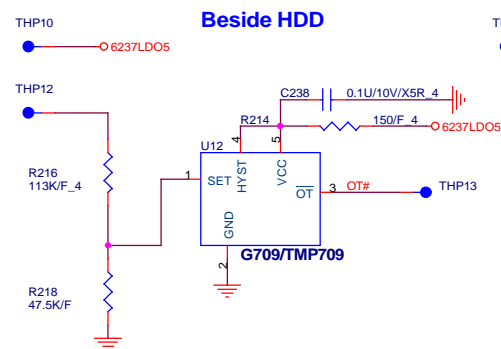
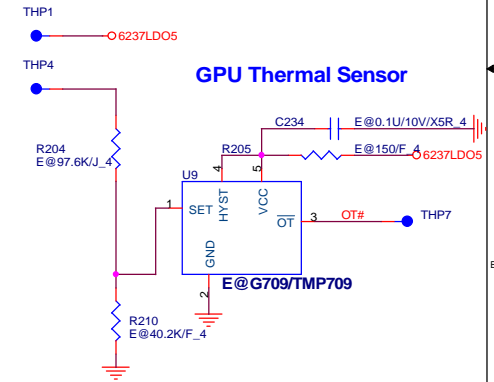
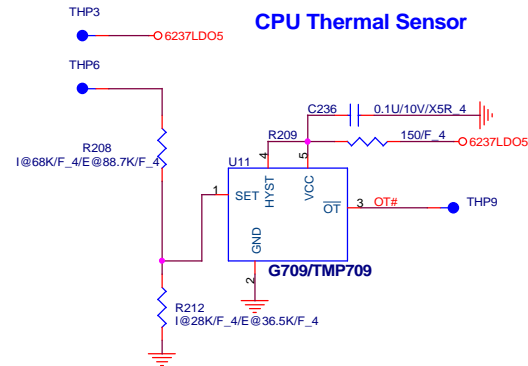
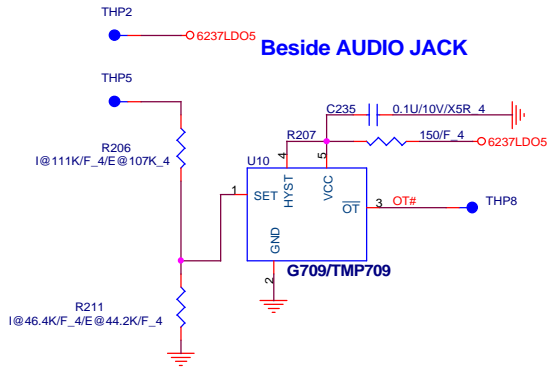

$$RSET(k\Omega) = 0.0012T^2 - 0.9308T + 96.147$$

95	18.5K
100	15K
107	10.3K
110	8.2K

DIS SKU

Location of IC	Temp	R-Set	Parts in BOM	Max	Min
Near CPU sensor temp	70	R208=36.87K	36.5K	71	70
Near GFX sensor temp	65	R146=40.72K	40.2K	66.3	65.1
Near AUDIO sensor temp	60	R345=44.62K	44.2K	61.2	60

UMA SKU

Location of IC	Temp	R-Set	Parts in BOM	Max	Min
Near CPU sensor temp	81	R208=28.63K	28K	82.3	81.4
Near AUDIO sensor temp	58	R345=46.2K	46.4K	58.4	57.1

Quanta Computer Inc.
PROJECT : HKC

Size	Document Number	Date	Sheet	Rev
	HDMI/Thermal IC	Thursday, January 31, 2013	19 of 40	1A

1. Level 1 Environment-related Substances Should Never be Used.
2. Recycled Resin and Coated Wire should be procured from Green Partners.

MB to USB board

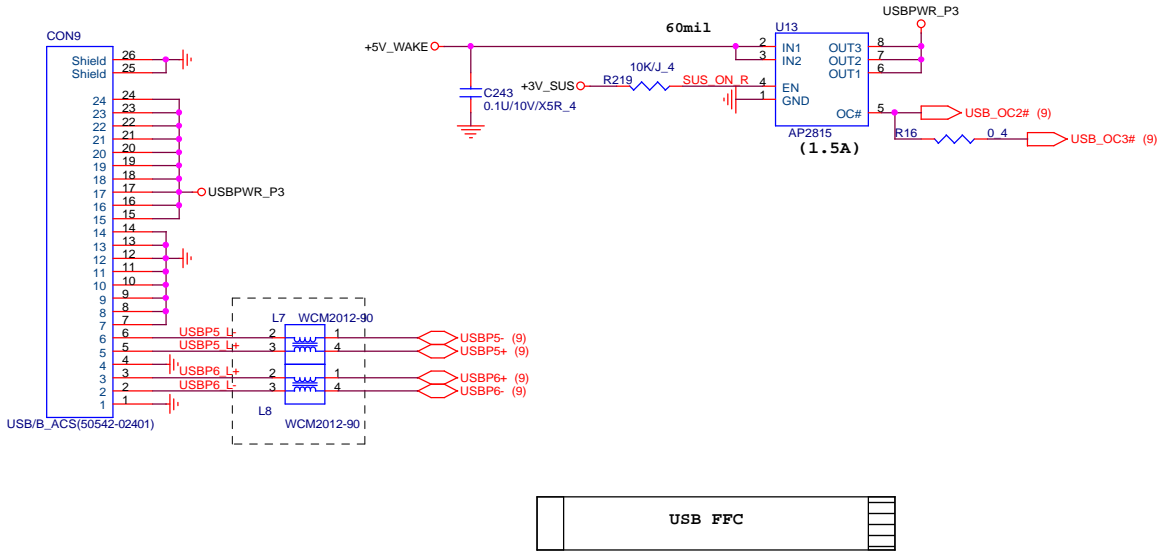

USB 3.0 PORT1

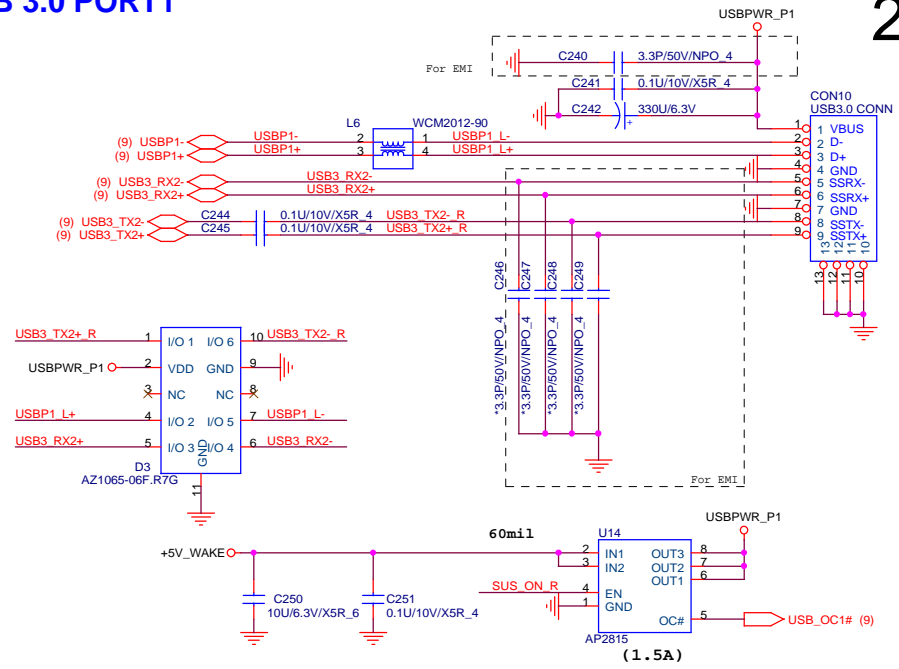

	TPS2540A		TPS2543	
ILIM_SEL	Pin15	Pin16	Pin15	Pin16
High	V			V
Low		V	V	

SDP : Standard Downstream Port
 CDP : Charging downstream port
 DCP : Dedicated Charging Port
 Enable/Disable : setting by BIOS

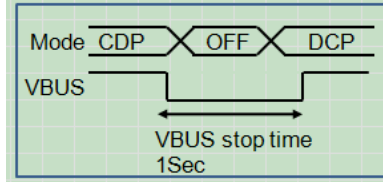

USB Charger

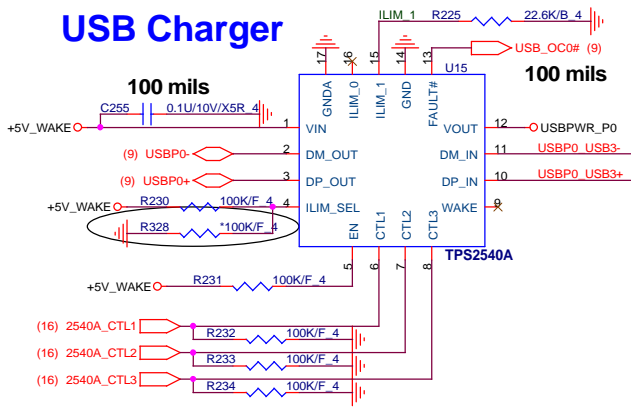

USB 3.0 PORT0

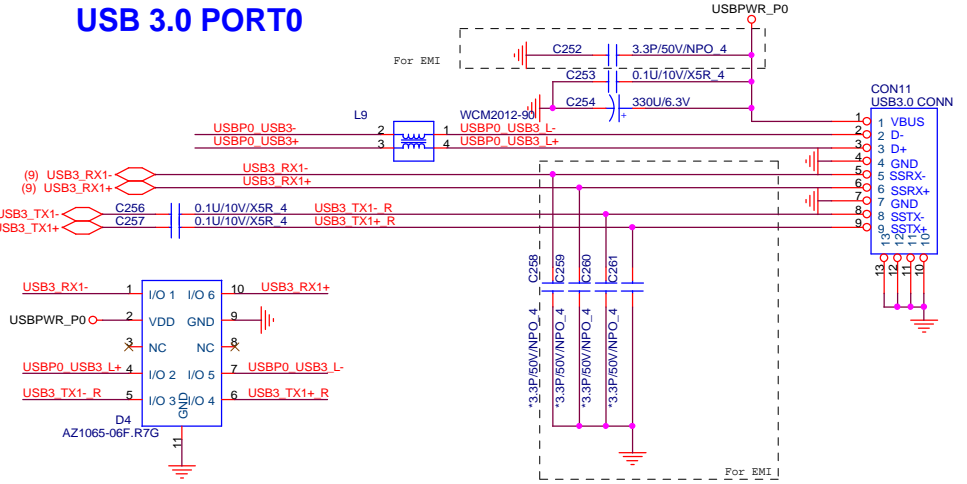

CTL_1	CTL_2	CTL_3	TPS 2540A/2543 Truth Table
0	0	0	OUT discharge, power switch OFF
0	X	1	DCP, Auto-detect (S3/S4/S5, 1.5A)
X	1	0	SDP, USB2.0 mode (S0, 0.5A)
1	0	0	DCP, BC SPEC1.2 only (S3/Deep standby/S4/S5, 1.5A)
1	0	1	DCP, Divider mode only (S3/S4/S5, 1.5A)
1	1	1	CDP (S0, 1.5A)

System State	USB Battery Charging Setting			
	Disable	C(1 2 3)	Enable	C(1 2 3)
S0		(X 1 0)	CDP	(1 1 1)
S3	SDP	(X 1 0)	DCP BC	(1 0 0)
DS3	Charger OFF	(0 0 0)	DCP BC	(1 0 0)
S4	Charger OFF	(0 0 0)	DCP BC	(1 0 0)
S5	Charger OFF	(0 0 0)	DCP BC	(1 0 0)

ILIM_SEL (I LIMIT(A)= 48000/R)		
HI	I_LIM_1	
LO	I_LIM_0	48000/22.6K=2.123A

Quanta Computer Inc.
 PROJECT : HKC
USB/USB Charger
 Date: Thursday, January 31, 2013 Sheet 20 of 40

1. LEVEL 1 ENVIRONMENT-RELATED SUBSTANCES SHOULD NEVER BE USED.
 2. RECYCLED RESIN AND COATED WIRE SHOULD BE PROCURED FROM GREEN PARTNERS.

WLAN/WIMAX/WIDI

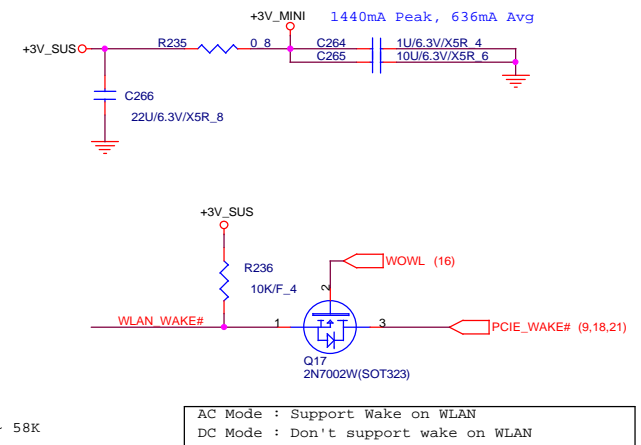
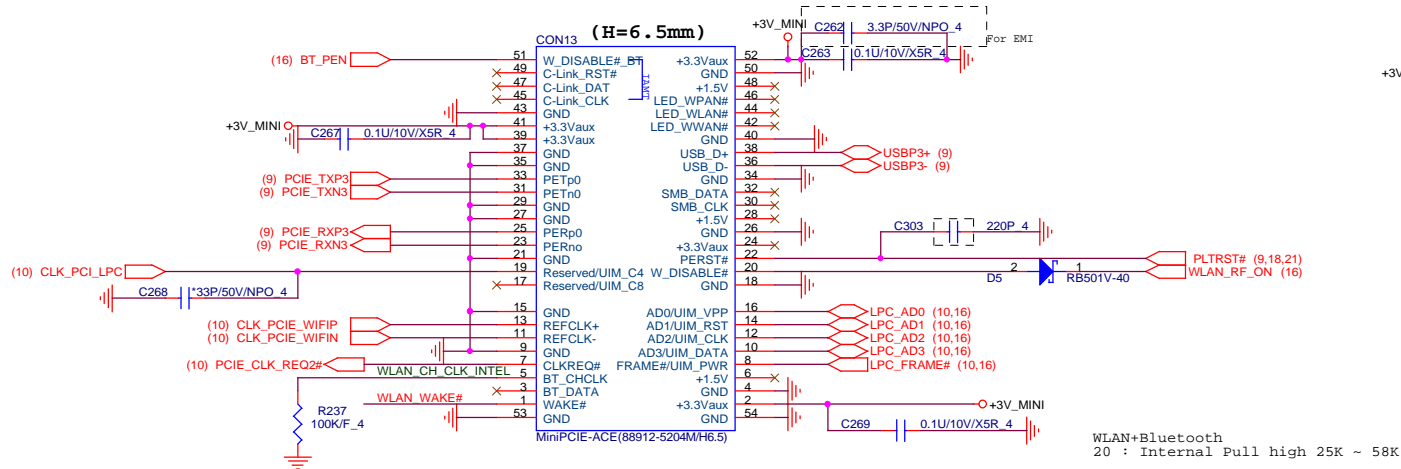

KB BACKLIGHT

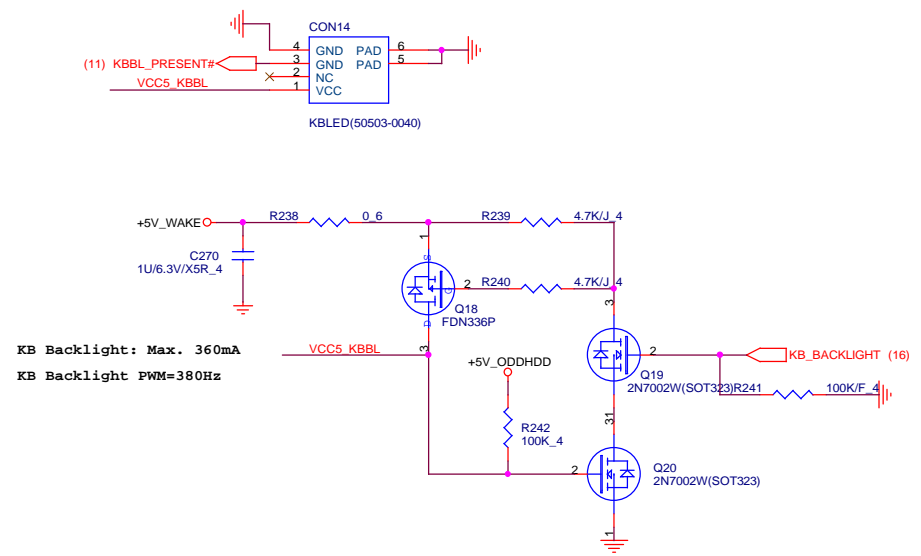



Quanta Computer Inc.
PROJECT : HKC

Size	Document Number	Rev
	WLAN/KB BL	1A

1. Level 1 Environment-related Substances should Never be Used.
2. Recycled Resin and Coated Wire should be procured from Green Partners. Date: Thursday, January 24, 2013 Sheet 22 of 40

ODD CONNECTOR

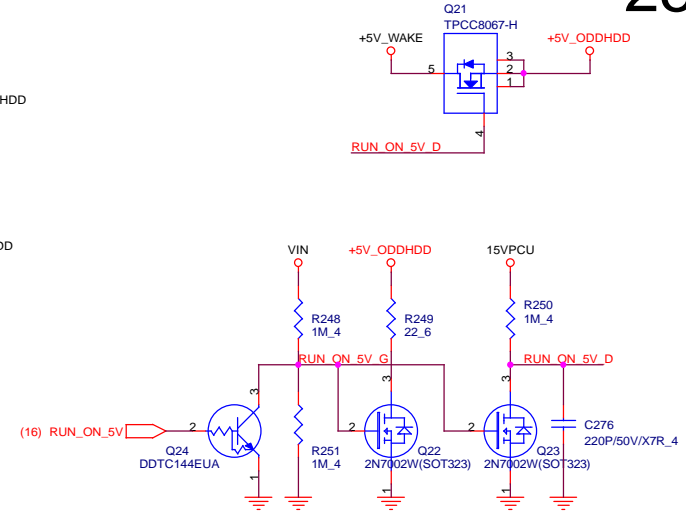
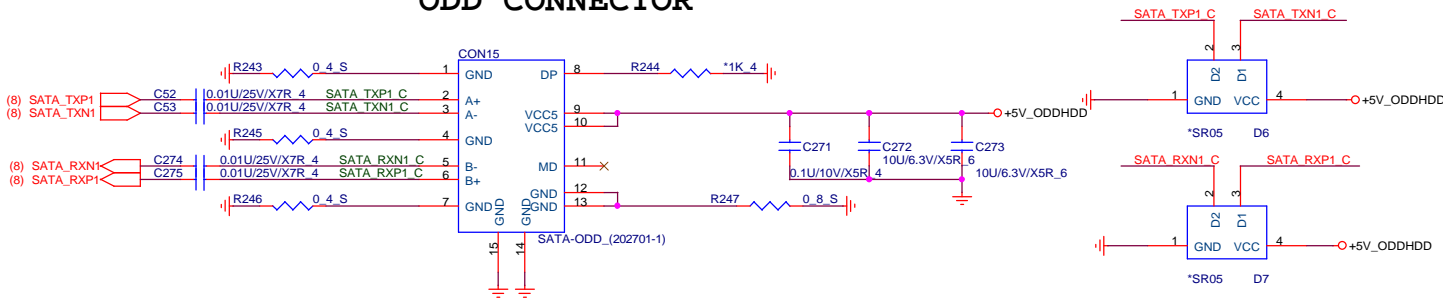

HDD CONNECTOR

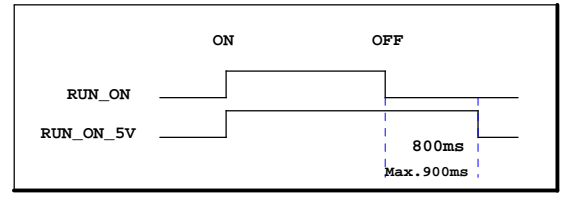
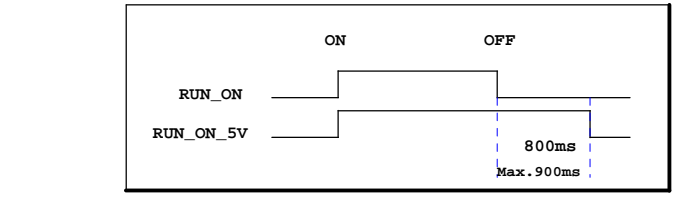
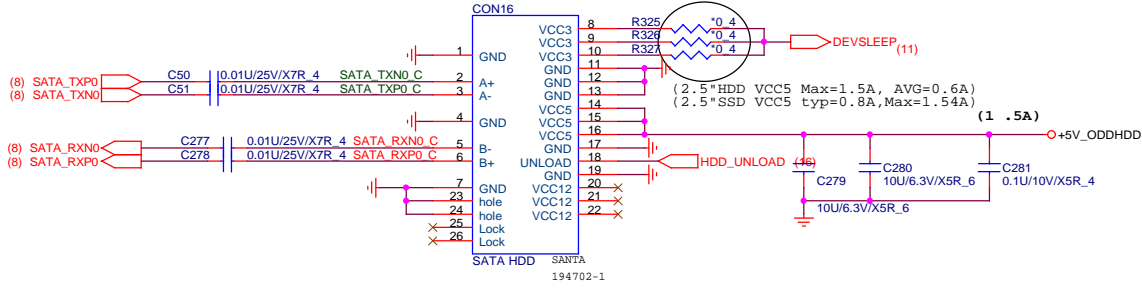

HDD PROTECT SPI INTERFACE

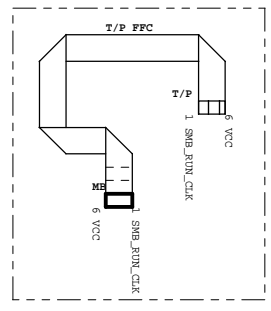
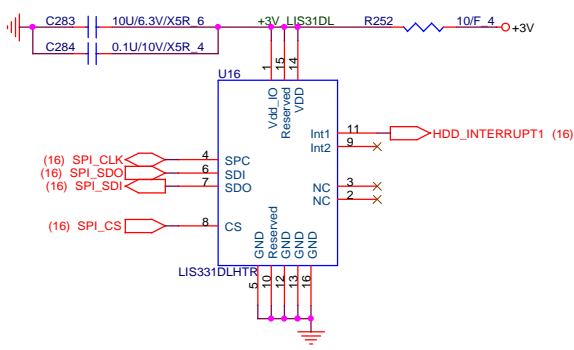

T/P Board to T/P

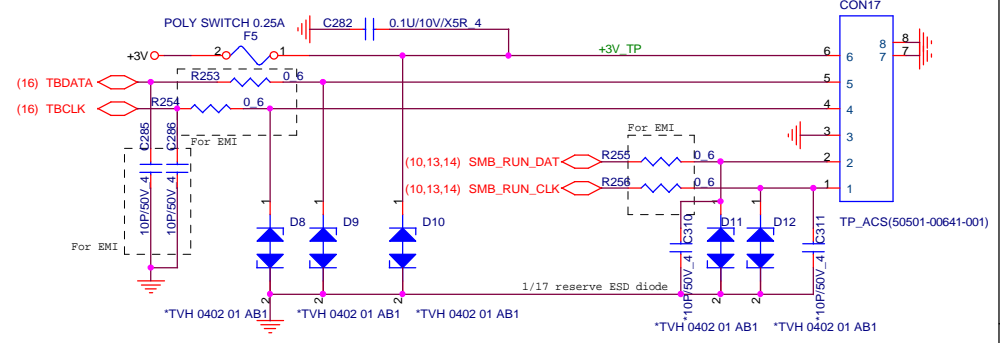

FAN

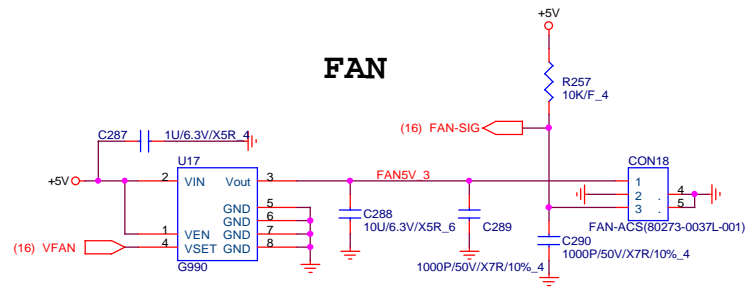

Quanta Computer Inc.
PROJECT : HKC

Size	Document Number	Rev
	HDD/ODD/TP/FAN	1A

1. Level 1 Environment-related Substances Should Never be Used.
2. Recycled Resin and Coated Wire should be procured from Green Partners.

Date: Thursday, January 31, 2013 Sheet 23 of 40

Camera

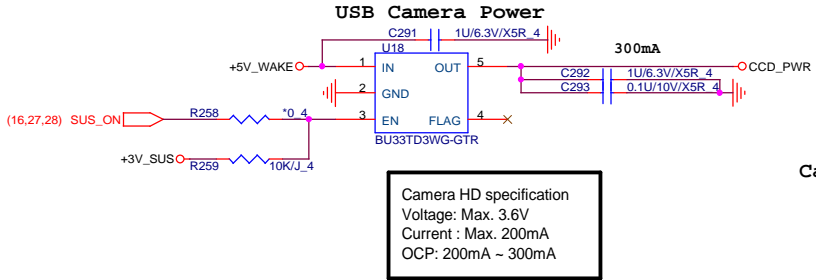

Camera HD specification
 Voltage: Max. 3.6V
 Current : Max. 200mA
 OCP: 200mA ~ 300mA

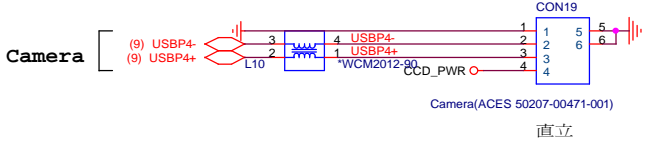

SATA LED

BATTERY LED

Power/Sleep LED

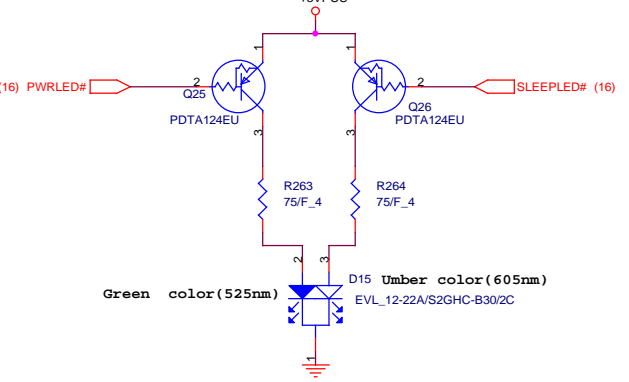
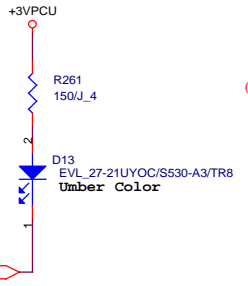
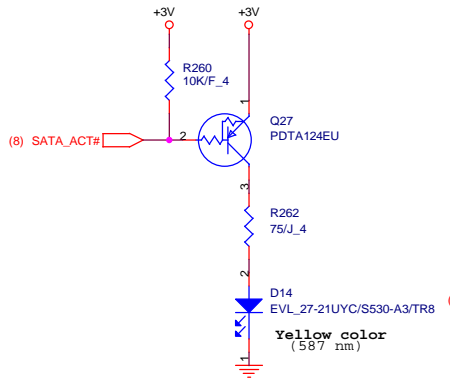

Power SW Board Connector

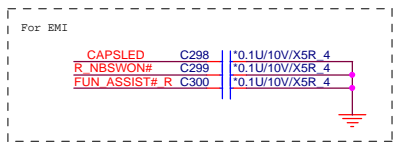
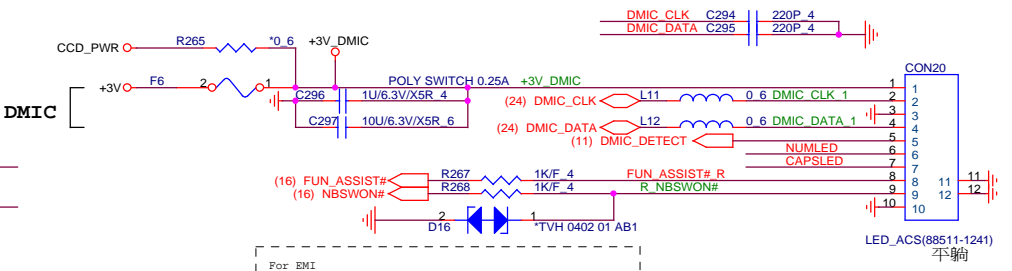
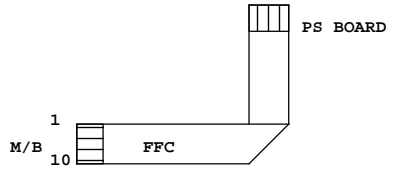

Quanta Computer Inc.
 PROJECT : HKC

Size: Document Number: LED/RF/KB/PS Rev: 1A
 Date: Thursday, January 24, 2013 Sheet: 25 of 40

1. Level 1 Environment-related Substances should Never be Used.
 2. Recycled Resin and Coated Wire should be procured from Green Partners.

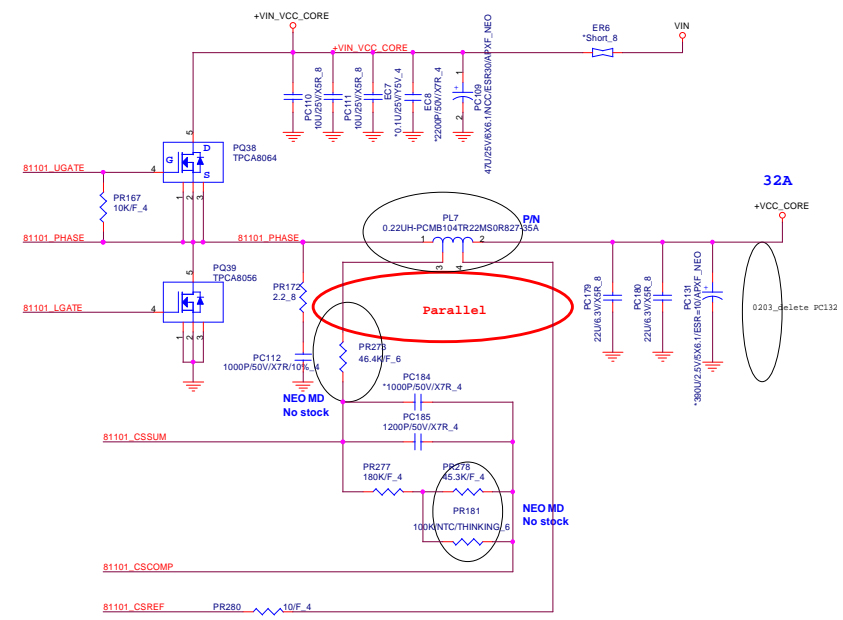
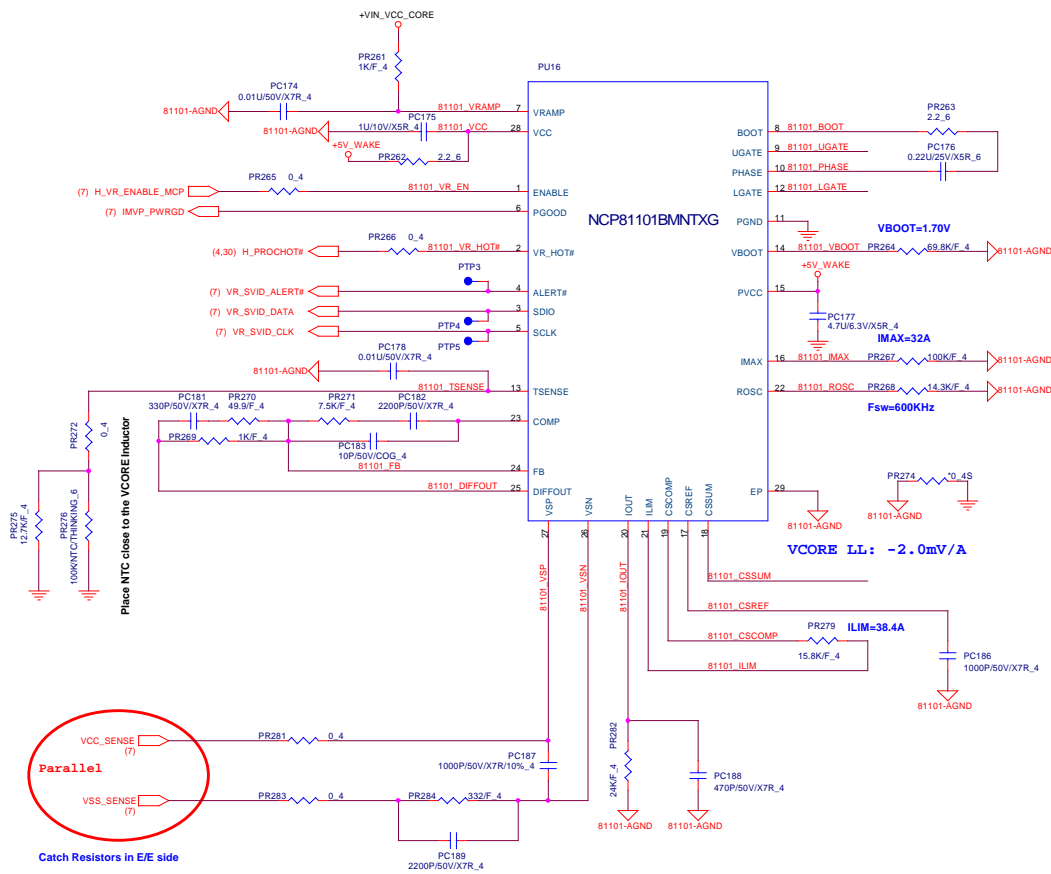

1. Level 1 Environment-related Substances should Never be Used.
 2. Recycled Resin and Coated Wire should be procured from Green Partners.

+1.05V

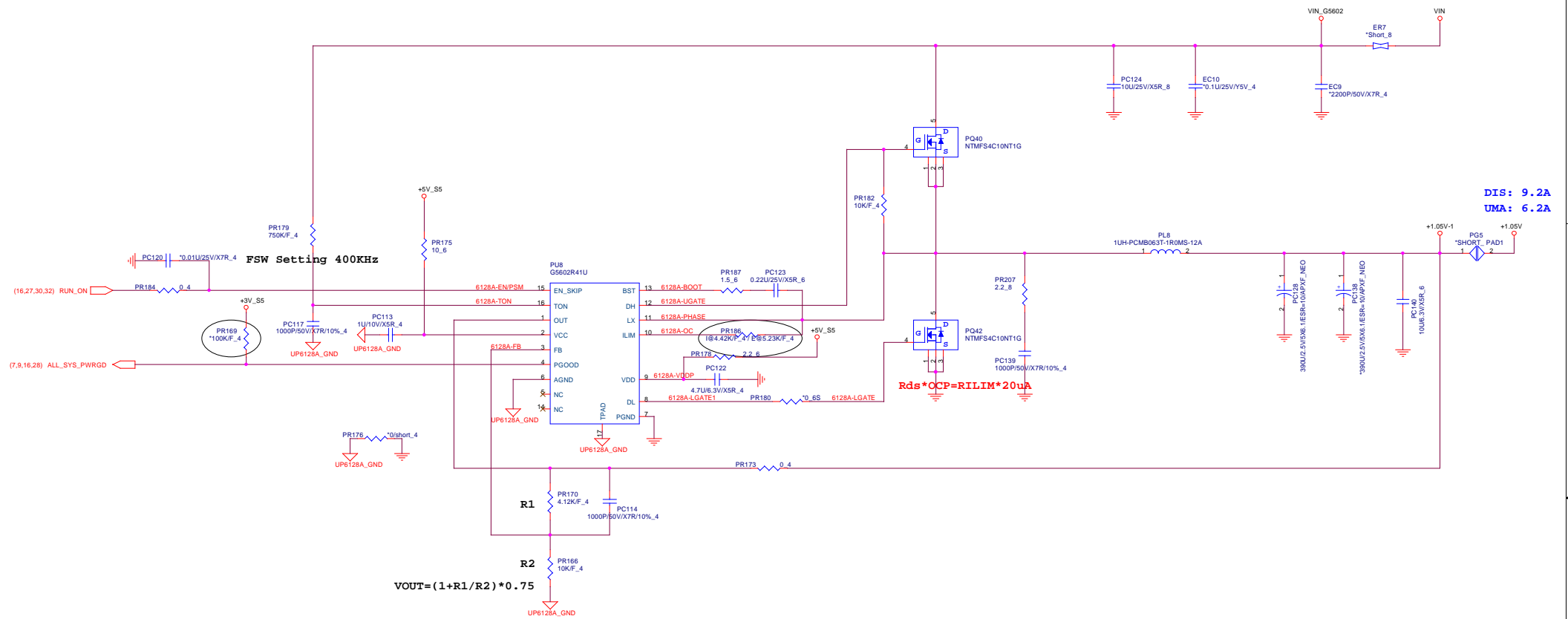

Quanta Computer Inc.
PROJECT : HKC

Size	Document Number	Rev
	+1.05V (UP1522RQDD)	1A

1.Level 1 Environment-related Substances Should Never be Used.
2.Recycled Resin and Coated Wire should be procured from Green Partners.

Date: Wednesday, January 30, 2013 Sheet 29 of 40

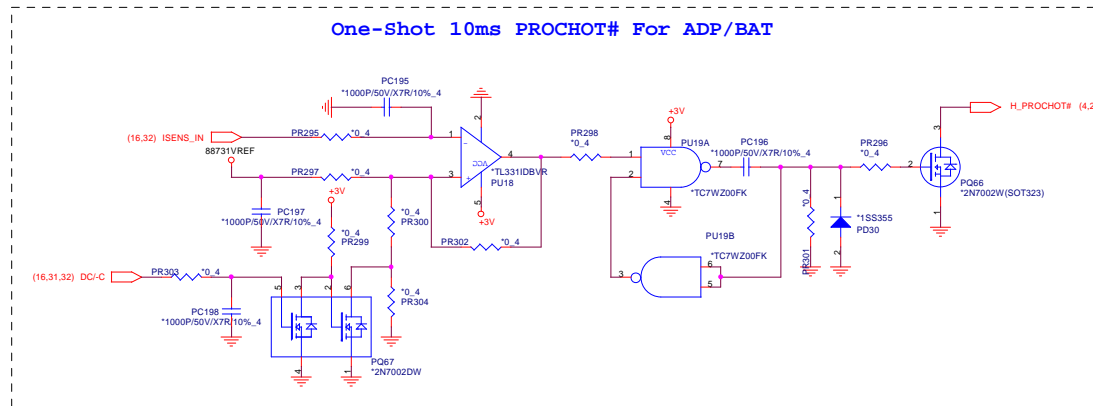
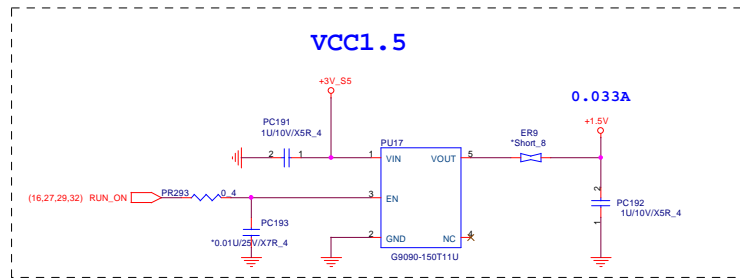

Thermal Protection and Battery VUP for VEDS

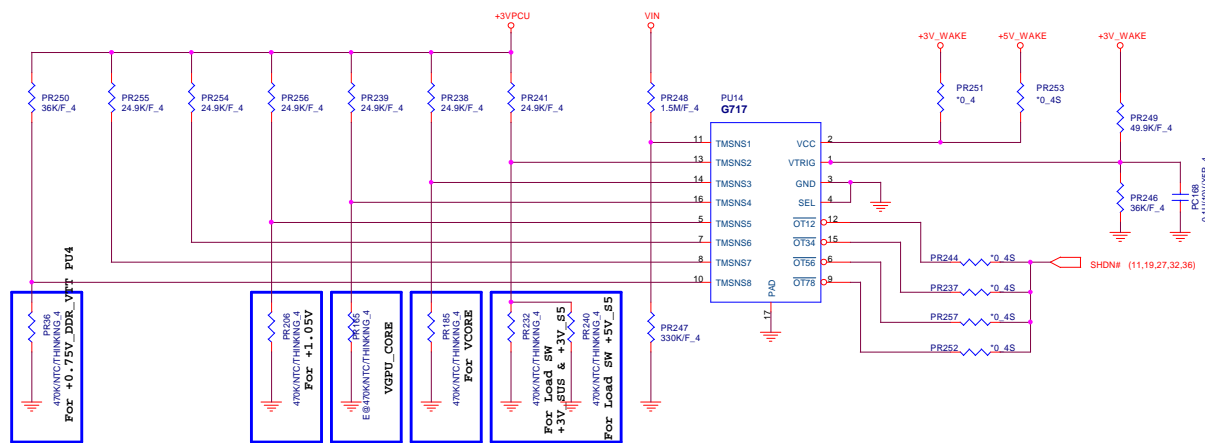

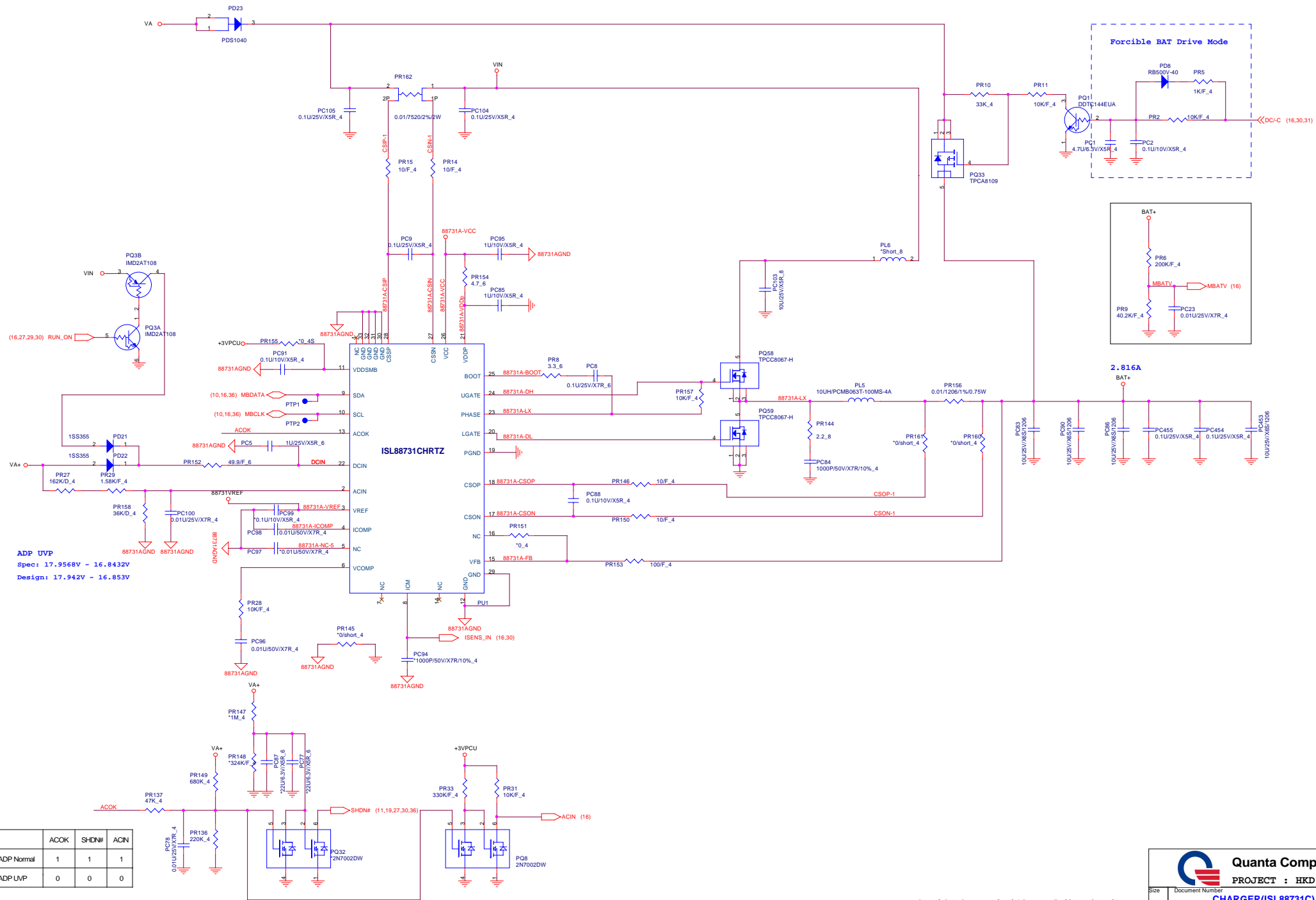

ADP LVP
 Spec: 17.9568V - 16.8432V
 Design: 17.942V - 16.853V

	ACOK	SHDN#	ACIN
ADP Normal	1	1	1
ADP LVP	0	0	0

Quanta Computer Inc.
 PROJECT : HKD
 CHARGER(ISL88731C)
 Date: Monday, February 04, 2013 Sheet 32 of 40

1.Level 1 Environment-related Substances Should Never be Used.
 2.Recycled Resin and Coated Wire should be procured from Green Partners.

VGA-CORE

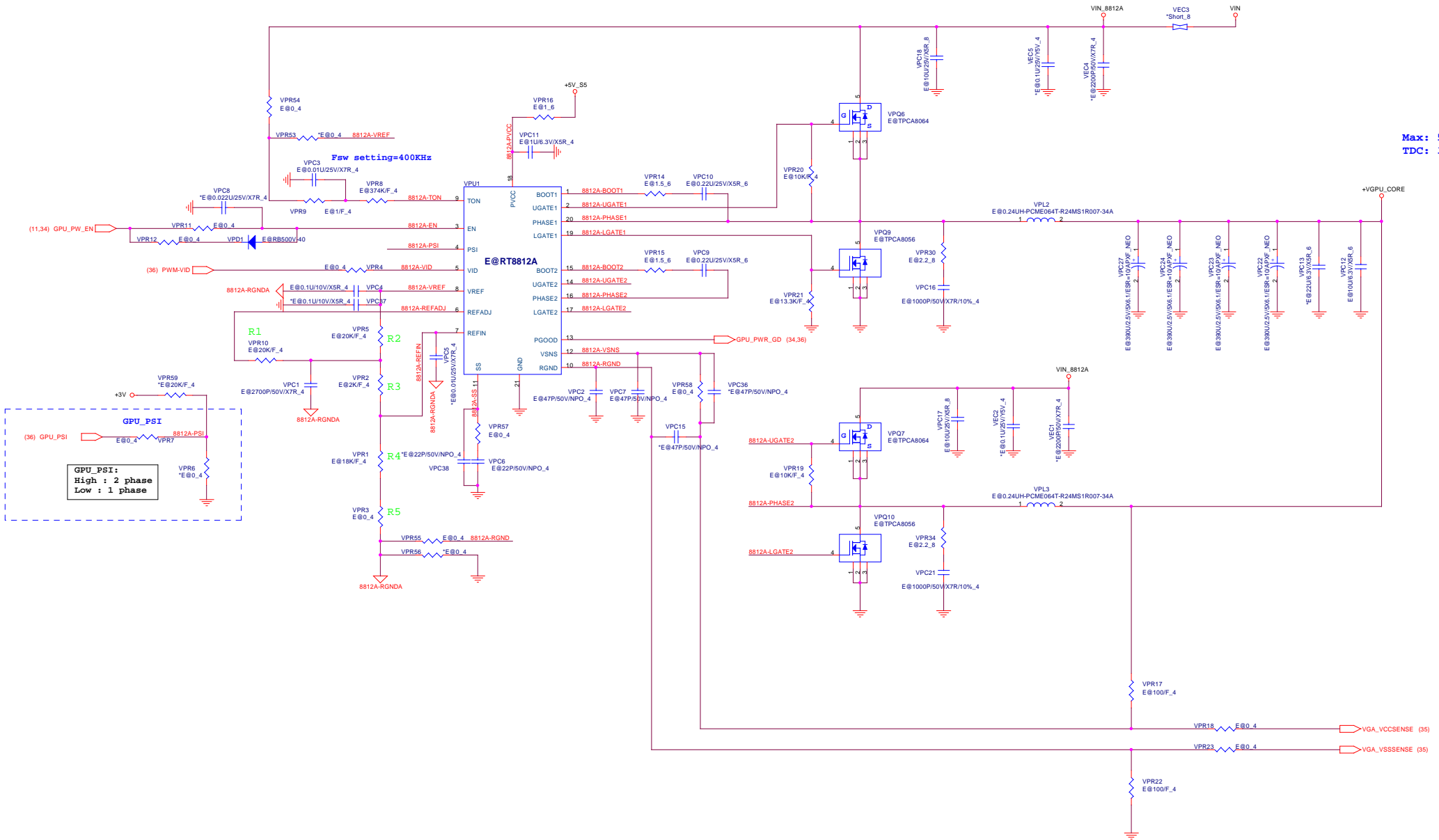

Max : 55A
TDC : 35A

GPU_PSI:
High : 2 phase
Low : 1 phase

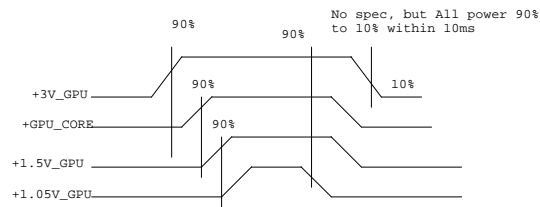
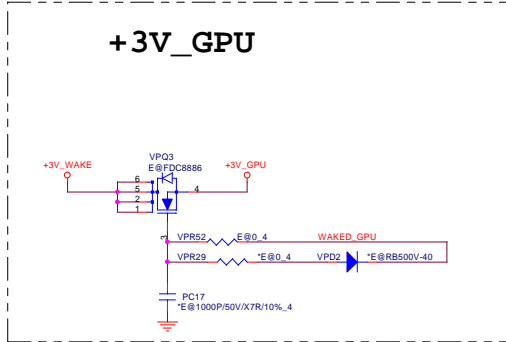
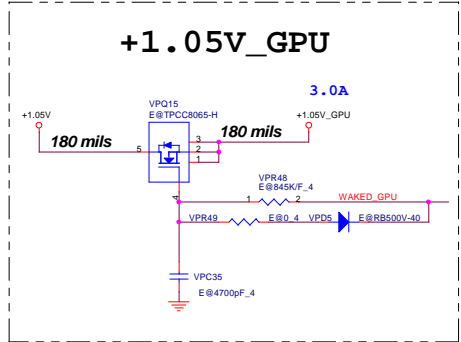
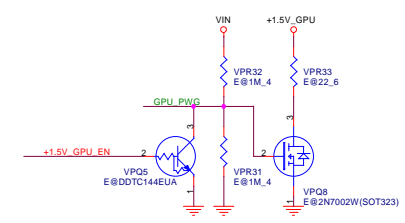
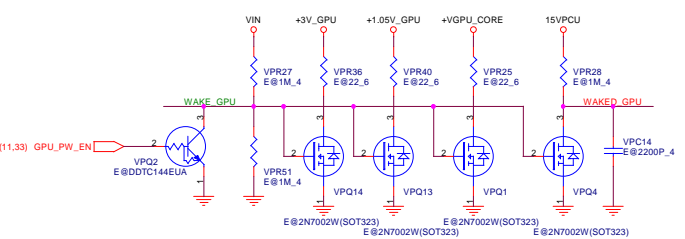
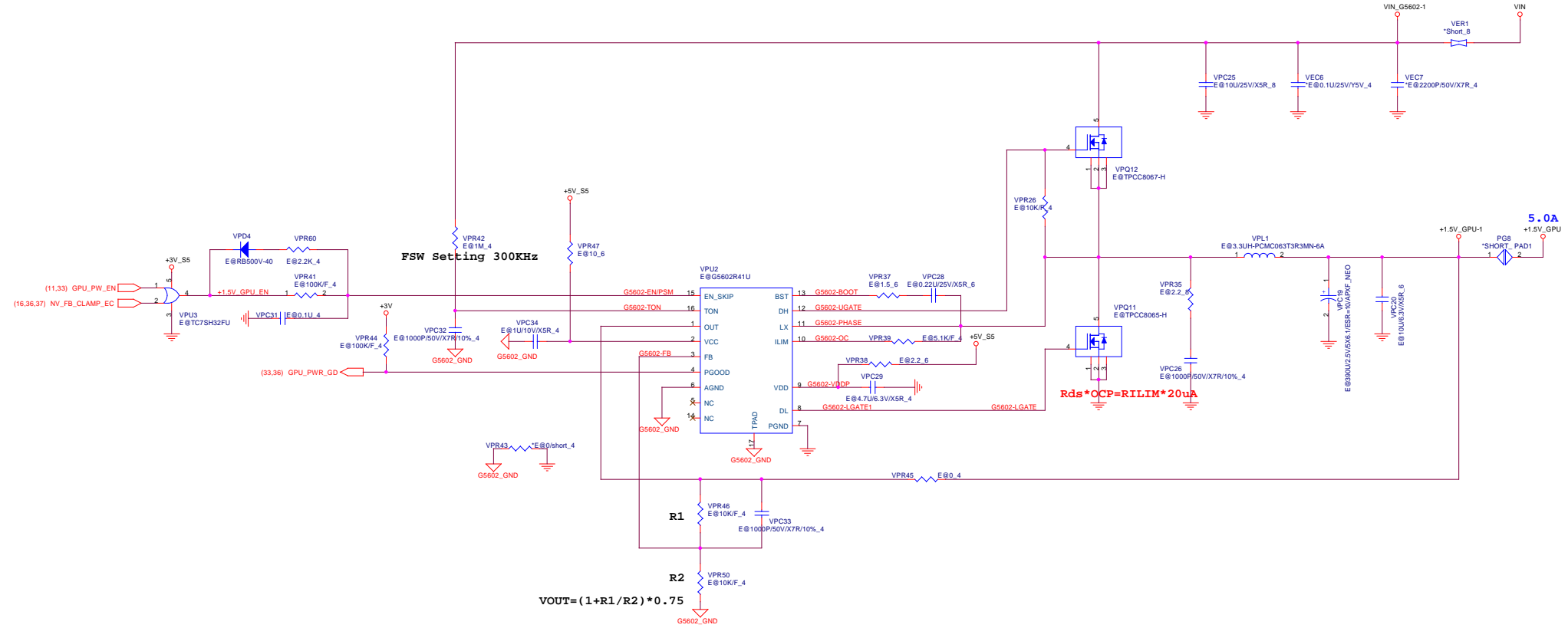

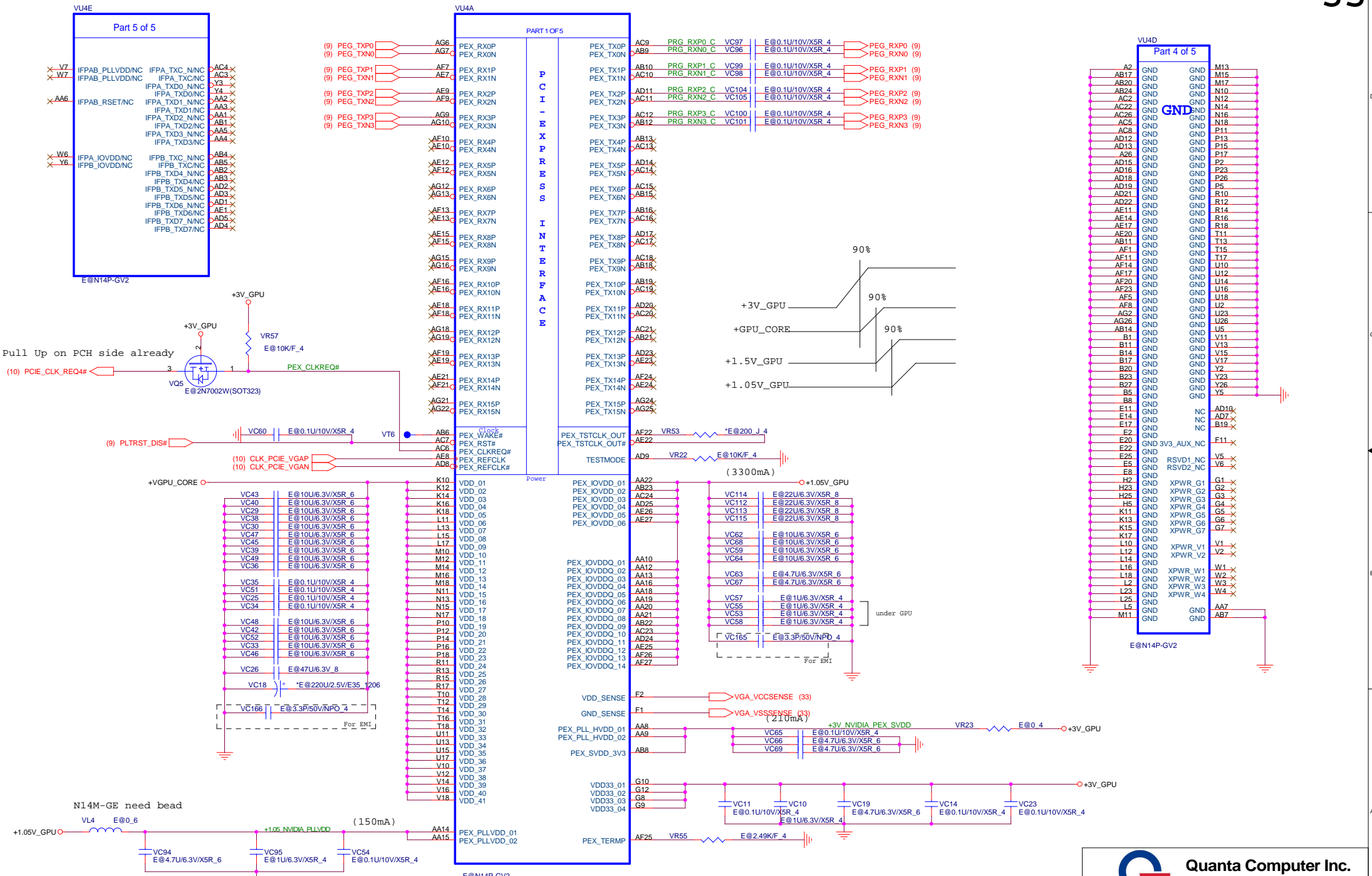

Quanta Computer Inc.
PROJECT : HKC
 Size Document Number **Nvidia 1/4** Rev 1A
 1.Level 1 Environment-related Substances Should Never be Used.
 2.Recycled Resin and Coated Wire should be procured from Green Partners.Date: Thursday, January 24, 2013 Sheet 35 of 40

For GC6 GPU Monitor Status (FB_CLAMP_MON)

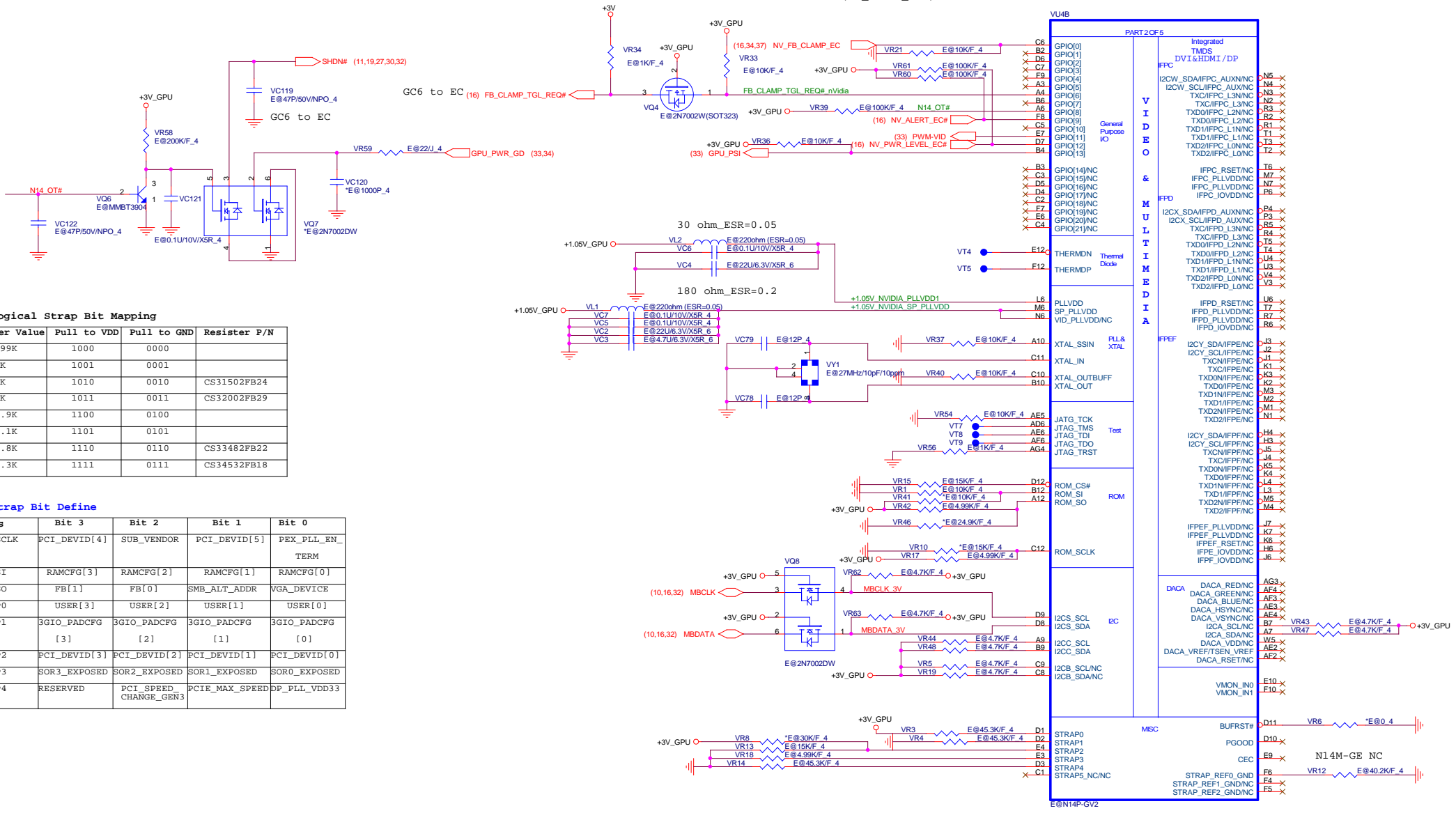

N14 Logical Strap Bit Mapping

Resistor Value	Pull to VDD	Pull to GND	Resistor P/N
4.99K	1000	0000	
10K	1001	0001	
15K	1010	0010	CS31502FB24
20K	1011	0011	CS32002FB29
24.9K	1100	0100	
30.1K	1101	0101	
34.8K	1110	0110	CS33482FB22
45.3K	1111	0111	CS34532FB18

N14 Strap Bit Define

Straps	Bit 3	Bit 2	Bit 1	Bit 0
ROM_SCLK	PCI_DEVID[4]	SUB_VENDOR	PCI_DEVID[5]	PEX_PLL_EN_TERM
ROM_SI	RAMCFG[3]	RAMCFG[2]	RAMCFG[1]	RAMCFG[0]
ROM_SO	FB[1]	FB[0]	SMB_ALT_ADDR	VGA_DEVICE
STRAP0	USER[3]	USER[2]	USER[1]	USER[0]
STRAP1	3GIO_PADCFG [3]	3GIO_PADCFG [2]	3GIO_PADCFG [1]	3GIO_PADCFG [0]
STRAP2	PCI_DEVID[3]	PCI_DEVID[2]	PCI_DEVID[1]	PCI_DEVID[0]
STRAP3	SOR3_EXPOSED	SOR2_EXPOSED	SOR1_EXPOSED	SOR0_EXPOSED
STRAP4	RESERVED	PCI_SPEED_CHANGE_GEN3	PCI_MAX_SPEED	DP_PLL_VDD33

	VRAM Capacity	VRAM Vender	ID	VR1	Mfr P/N	Quanta P/N
N14M-LP	128Mx16 DDR3	Samsung	0111	PD45.3K	K4W2G1646E-BC11	AKD5MGGT525
		Hynix	0110	PD34.8K	H5TQ2G63DFR-11C	AKD5MGWTW15
N14P-GV2	256Mx16 DDR3	Samsung	0011	PD20K	K4W4G1646B-HC11	AKD5MGWT525
		Hynix	0010 (TBD)	PD15K	H5TC4G63AFR-11C	AKD5PGWTW10

1. Level 1 Environment-related Substances Should Never be Used.
 2. Recycled Resin and Coated Wire should be procured from Green Partners.

Quanta Computer Inc.
 PROJECT : HKC
 Size: Document Number: **Nvidia 2/4** Rev 1A
 Date: Thursday, January 24, 2013 Sheet 36 of 40

Up Side VRAM TOP/BOT

TOP

BOT

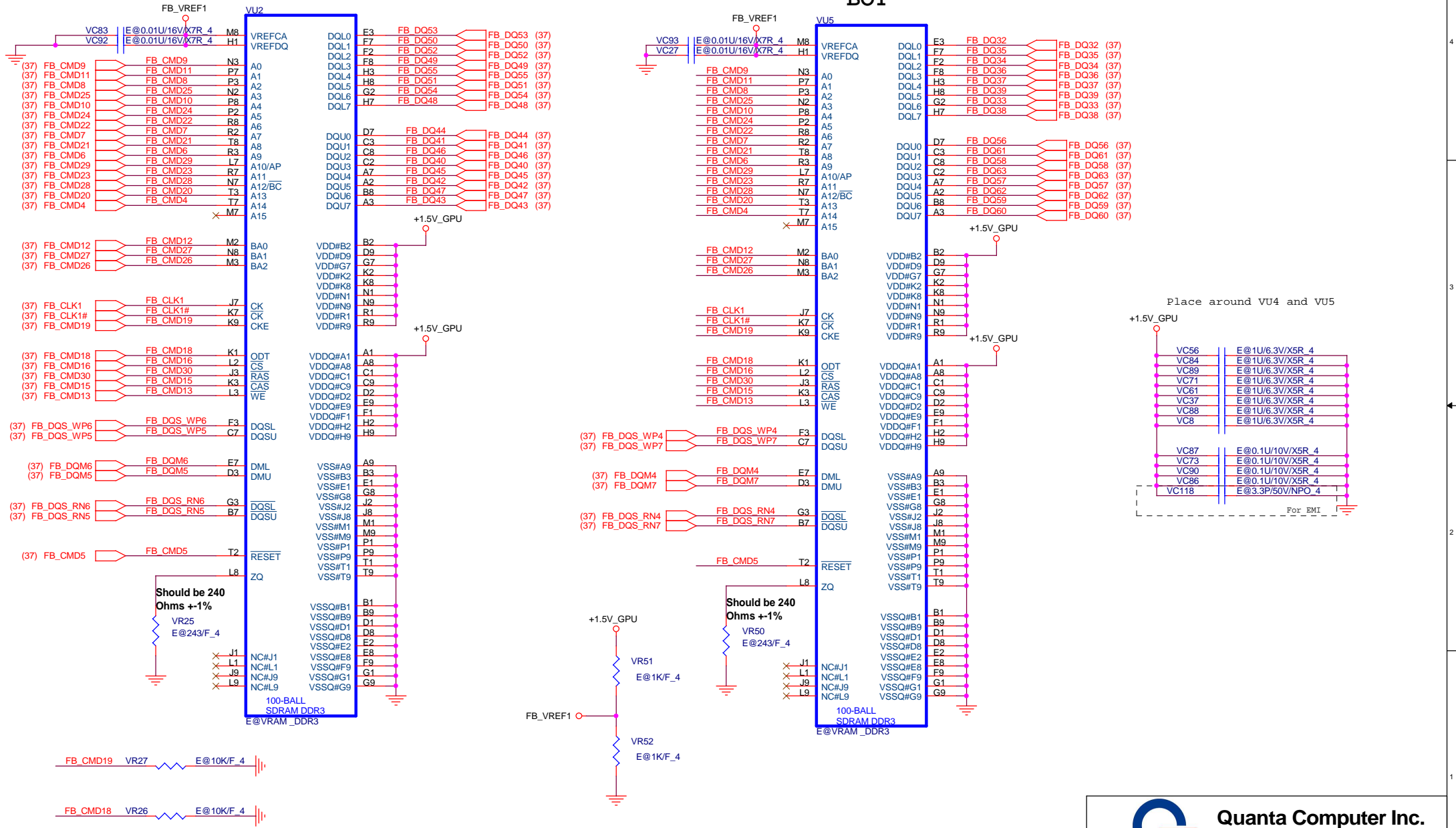

Quanta Computer Inc.
PROJECT : HKC

Size	Document Number	Rev
	VRAM 4/4	1A
Date:	Thursday, January 24, 2013	Sheet 38 of 40

1.Level 1 Environment-related Substances Should Never be Used.
2.Recycled Resin and Coated Wire should be procured from Green Partners.

Woofers frequency 400Hz

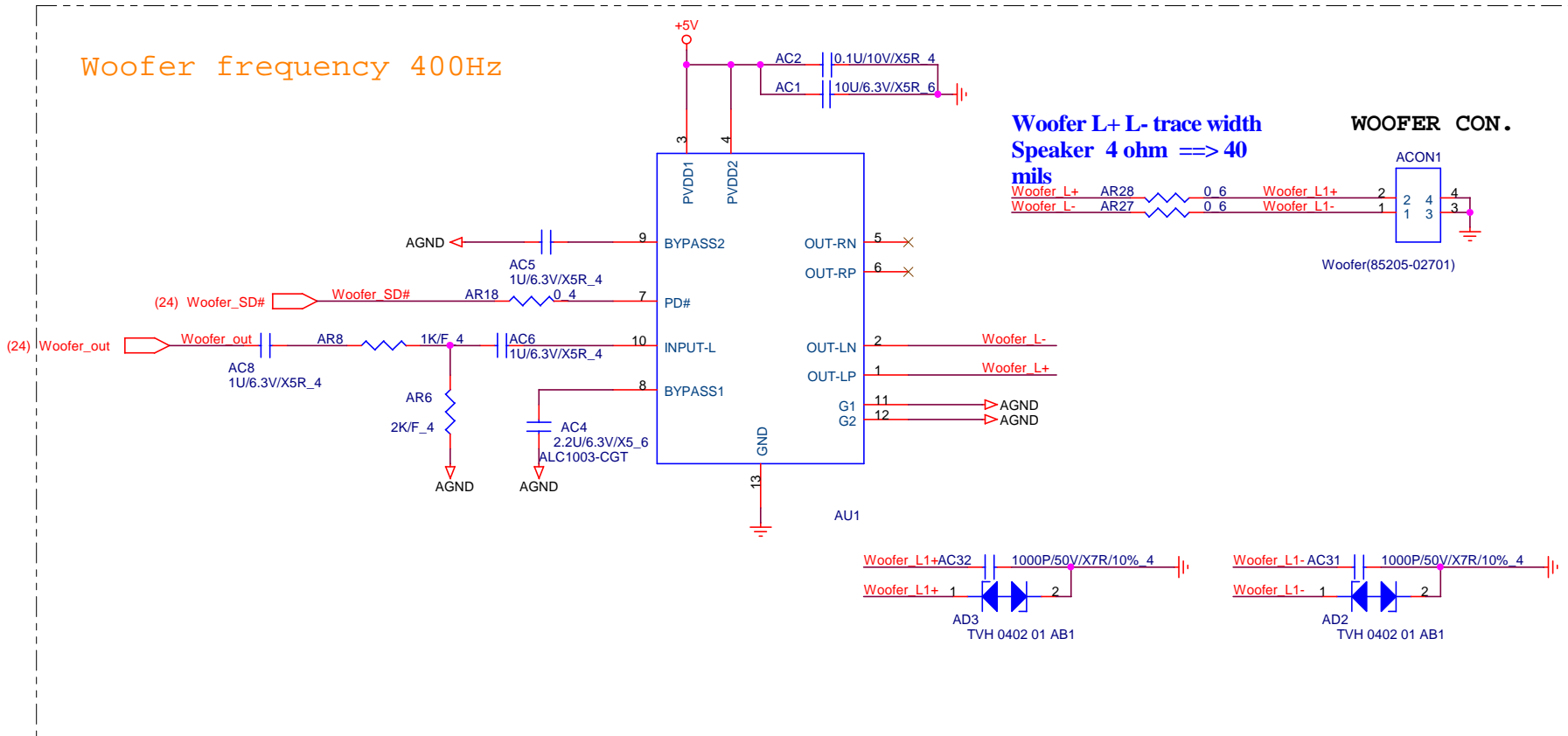

Woofer L+ L- trace width
Speaker 4 ohm ==> 40
mils

WOOFER CON.

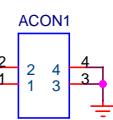

Woofer(85205-02701)

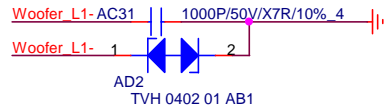

1.Level 1 Environment-related Substances Should Never be Used.
2.Recycled Resin and Coated Wire should be procured from Green Partners.

 Quanta Computer Inc. PROJECT : HKC		Size	Document Number	Rev
		Audio Codec Woofer		1A
Date:	Thursday, January 24, 2013	Sheet	39	of 40

USB PORT Architecture	
PORT 0	USB3.0
PORT 1	USN3.0
PORT 2	USN2.0
PORT 3	USB2.0
PORT 4	NFC
PORT 5	N/A
PORT 6	N/A
PORT 7	N/A
PORT 8	N/A
PORT 9	WiMax/BT
PORT 10	Camera
PORT 11	Card Reader
PORT 12	Touch Screen
PORT 13	N/A

PCIE BUS	
PORT 1	WLAN Port
PORT 2	CARD READER
PORT 3	GLAN(RTL8111G)
PORT 4	N/A
PORT 5	N/A
PORT 6	N/A
PORT 7	N/A
PORT 8	N/A

SATA BUS	
PORT 0	HDD
PORT 1	N/A
PORT 2	N/A
PORT 3	N/A
PORT 4	ODD
PORT 5	N/A

SM BUS	MBCLK/MBDATA	WRITE	READ	Function
ISL88731CHRTZ	0001 001X	0001 0010	0001 0011	Charger
Nvidia	1001 1110	-	1001 1110	Graphice
LIS331DL	0011 101X	0011 1010	0011 1011	G Sensor

SM BUS	MBCLK_BAT/MBDATA_BAT	WRITE	READ	Function
VGP-BPS35A	0001 011X	0001 0110	0001 0111	Battery

SM BUS	SMB_PCH_CLK/SMB_PCH_DAT	WRITE	READ	Function
DIMM Module0	1010 000X	1010 0000	1010 0001	DDRIII
DIMM Module 1	1010 010X	1010 0100	1010 0101	DDRIII
Synaptics	0010 110X	0010 1100	0010 1101	Click PAD

	R363(High) R362(Low)	R294(High) R297(low)
	Board ID3	Board ID0
14"/HK6	0	0
15"/HK5	0	1
17"/HK7	1	0

Board ID1 (VRAM Vendor)	Samaung(1)	Hynix(0)
R47(High)	Stuff	No Stuff
R48(Low)	No Stuff	Stuff

Board ID2		
14" 4PCS	1G	512M
15" 8PCS	1G	2G
R39(High)	Stuff	No Stuff
R27(Low)	No Stuff	Stuff

PCBA SKU	Discrete	UMA
R277(Pull High)	Stuff	No Stuff
R275(Pull Low)	No Stuff	Stuff

OS status	S0	S3	DS3	(Soft OFF)	(Soft OFF)	(Soft OFF)	(Soft OFF)	(Soft OFF)
H/W status	S0	S3	DS3	S4 (Win8 off) RTC wake Enable WOLAN Enable	S4 (Win8 off) RTC wake Disable WOLAN Disable	S5 Charge Enable	S5 Charge Disable WoL Disable	S5 WoL Enable
RUN_ON	H	L	L	L	L	L	L	L
+3V	H	L	L	L	L	L	L	L
+5V	H	L	L	L	L	L	L	L
+0.675V_DDR_VTT	H	L	L	L	L	L	L	L
+1.05V	H	L	L	L	L	L	L	L
+0.85V	H	L	L	L	L	L	L	L
+1.5V	H	L	L	L	L	L	L	L
+3V_GPU	H	L	L	L	L	L	L	L
+1.05V_GPU	H	L	L	L	L	L	L	L
+VGPU_CORE	H	L	L	L	L	L	L	L
+VCC_CORE	H	L	L	L	L	L	L	L
SUS_ON	H	H	H	L	L	L	L	L
+1.35V_SUS	H	H	H	L	L	L	L	L
S5_ON	H	H	L	H	L	L	L	H
+5V_S5	H	H	L	H	L	L	L	H
+3V_S5	H	H	L	H	L	L	L	H
EC_WAKE_ON	H	H	H	H	L	H	L	H
+3V_WAKE	H	H	H	H	L	H	L	H
+5V_WAKE	H	H	H	H	L	H	L	H
DEEP_EC_EN	H	H	H	H	L	L	L	L
+3V_S5_DSW	H	H	H	H	L	L	L	L
+3V_SUS	H	H	L	L	L	L	L	L