

ACLU1&ACLU2

(G40-70 & G50-70)

NM-A271 Rev 1.0 Schematic

Intel Haswell/Broadwell U-Processor with DDRIII + AMD Jet-LE/Topaz-XT GPU

2013-12-17

REV:1.0

Security Classification	LC Future Center Secret Data			Title		
Issued Date	2013/08/08	Deciphered Date	2013/08/05	Cover Page		
THIS SHEET OF ENGINEERING DRAWING IS THE PROPRIETARY PROPERTY OF LC FUTURE CENTER, AND CONTAINS CONFIDENTIAL AND TRADE SECRET INFORMATION. THIS SHEET MAY NOT BE TRANSFERRED FROM THE CUSTODY OF THE COMPETENT DIVISION OF R&D DEPARTMENT EXCEPT AS AUTHORIZED BY LC FUTURE CENTER NEITHER THIS SHEET NOR THE INFORMATION IT CONTAINS MAY BE USED BY OR DISCLOSED TO ANY THIRD PARTY WITHOUT PRIOR WRITTEN CONSENT OF LC FUTURE CENTER.				Size Custom	Document Number ACLU1 & ACLU2	Rev 1.0
				Date:	Thursday, December 19, 2013	Sheet 1 of 59

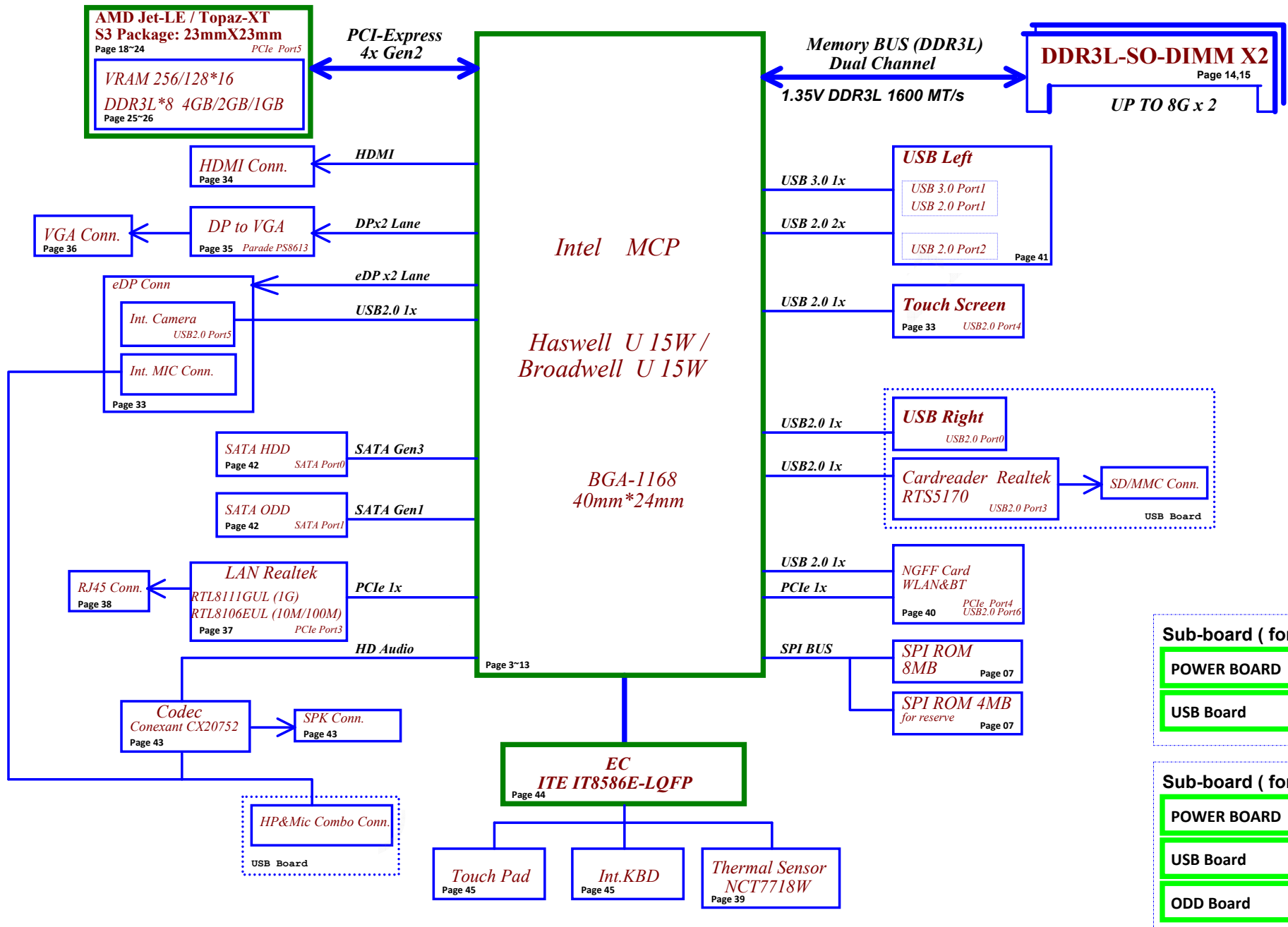

Security Classification	LC Future Center Secret Data		
Issued Date	2013/08/08	Deciphered Date	2013/08/05
THIS SHEET OF ENGINEERING DRAWING IS THE PROPRIETARY PROPERTY OF LC FUTURE CENTER, AND CONTAINS CONFIDENTIAL AND TRADE SECRET INFORMATION. THIS SHEET MAY NOT BE TRANSFERRED FROM THE CUSTODY OF THE COMPETENT DIVISION OF R&D DEPARTMENT EXCEPT AS AUTHORIZED BY LC FUTURE CENTER. NEITHER THIS SHEET NOR THE INFORMATION IT CONTAINS MAY BE USED BY OR DISCLOSED TO ANY THIRD PARTY WITHOUT PRIOR WRITTEN CONSENT OF LC FUTURE CENTER.			

Title		
Block Diagram		
Size	Document Number	Rev
Custom	ACLU1 & ACLU2	1.0
Date:	Thursday, December 19, 2013	Sheet 2 of 59

Voltage Rails (O --> Means ON , X --> Means OFF)

Power Plane / State	B+	+3VALW +5VALW	+3VALW_PCH	+1.35V	+5VS +3VS +1.5VS +1.35VS +1.05VS +0.675VS CPU_CORE +VGA_CORE +3VGS +1.8VGS +1.35VGS +0.95VGS
S0	O	O	O	O	O
S3	O	O	O	O	X
S3 Battery only	O	O	O	O	X
S5 S4/AC Only	O	O	O	X	X
S5 S4 Battery only	O	X	X	X	X
S5 S4 AC & Battery don't exist	X	X	X	X	X

STATE	SIGNAL	SLP_S1#	SLP_S3#	SLP_S4#	SLP_S5#	+VALW	+V	+VS	Clock
Full ON		HIGH	HIGH	HIGH	HIGH	ON	ON	ON	ON
S1 (Power On Suspend)		LOW	HIGH	HIGH	HIGH	ON	ON	ON	LOW
S3 (Suspend to RAM)		LOW	LOW	HIGH	HIGH	ON	ON	OFF	OFF
S4 (Suspend to Disk)		LOW	LOW	LOW	HIGH	ON	OFF	OFF	OFF
S5 (Soft OFF)		LOW	LOW	LOW	LOW	ON	OFF	OFF	OFF

USB Port Table

USB 2.0 EHCI1		USB 3.0 XHCI	
0	USB Port (Right Side)		
1	USB Port1 (Left Side)	1	USB Port1 (Left Side)
2	USB Port2 (Left Side)	2	
3	Cardreader	3	
4	TOUCH PANEL	4	
5	Camera		
6	NGFF(WLAN)		
7			

BOM Structure Table

BOM Structure	BTO Item
@	Not stuff
100M@	100M LAN Part
14@	For 14" part
15@	For 15" part
AOAC@	AOAC support part
GIGA@	GIGA LAN Part
JET@	For AMD Jet GPU part
ME@	ME part(connector, hole)
PX@	Discrete GPU SKU part
RANKA@	For VRAM RankA part
RANKB@	For VRAM RankB part
TOPAZ@	For AMD Topaz GPU part
TS@	For support touch panel sku part
UMA@	UMA SKU part
H2@	Hynix 128Mx16 VRAM part
H4@	Hynix 256Mx16 VRAM part
M2@	Micron 128Mx16 VRAM part
M4@	Micron 256Mx16 VRAM part
S2@	Samsung 128Mx16 VRAM part
S4@	Samsung 256Mx16 VRAM part
H2GX8@	Hynix 128Mx16 VRAM x8pcs sku
H4GX4@	Hynix 256Mx16 VRAM x4pcs sku
M4GX4@	Micron 256Mx16 VRAM x4pcs sku
CD@	Cost down part

SMBUS Control Table

	SOURCE	VGA	BATT	IT8586E	SODIMM	WLAN WIMAX	Thermal Sensor	PCH	TP Module	charger
EC_SMB_CK1 EC_SMB_DA1	IT8586E +3VALW	X	V	V +3VALW	X	X	X	X	X	V
EC_SMB_CK2 EC_SMB_DA2	IT8586E +3VS	V +3VGS	X	V +3VS	X	X	V +3VS	V +3VALW_PCH	X	X
PCH_SMB_CLK PCH_SMB_DATA	PCH +3VALW_PCH	X	X	X	V +3VS	V +3VS	X	V +3VALW_PCH	X	X

PCIe PORT LIST

Port	Device
1	
2	
3	LAN
4	WLAN
5	Discrete GPU
6	

EC SM Bus1 address

Device	Address
Smart Battery	0X16
Charger	0001 0010 b

EC SM Bus2 address

Device	Address
Thermal Sensor NCT7718W	1001_100xb
VGA	0x41(default)
PCH	need to update

PCH SM Bus address

Device	Address
DDR DIMMA	1010 000Xb
DDR DIMMB	1010 010Xb
Wlan	Rsvd

Security Classification	LC Future Center Secret Data	
Issued Date	2013/08/08	Deciphered Date 2013/08/05
THIS SHEET OF ENGINEERING DRAWING IS THE PROPRIETARY PROPERTY OF LC FUTURE CENTER, AND CONTAINS CONFIDENTIAL AND TRADE SECRET INFORMATION. THIS SHEET MAY NOT BE TRANSFERRED FROM THE CUSTODY OF THE COMPETENT DIVISION OF DEPARTMENT EXCEPT AS AUTHORIZED BY LC FUTURE CENTER. NEITHER THIS SHEET NOR THE INFORMATION IT CONTAINS MAY BE USED BY OR DISCLOSED TO ANY THIRD PARTY WITHOUT PRIOR WRITTEN CONSENT OF LC FUTURE CENTER.		

Title	Notes List
Document Number	ACL01 & ACLU2
Date	Thursday, December 19, 2013
Sheet	3 of 59



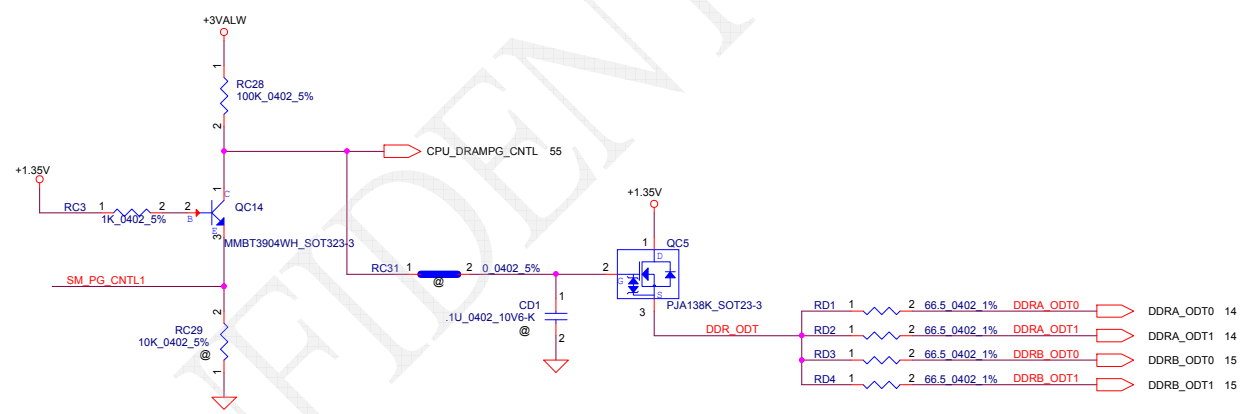
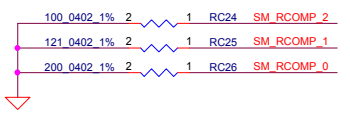
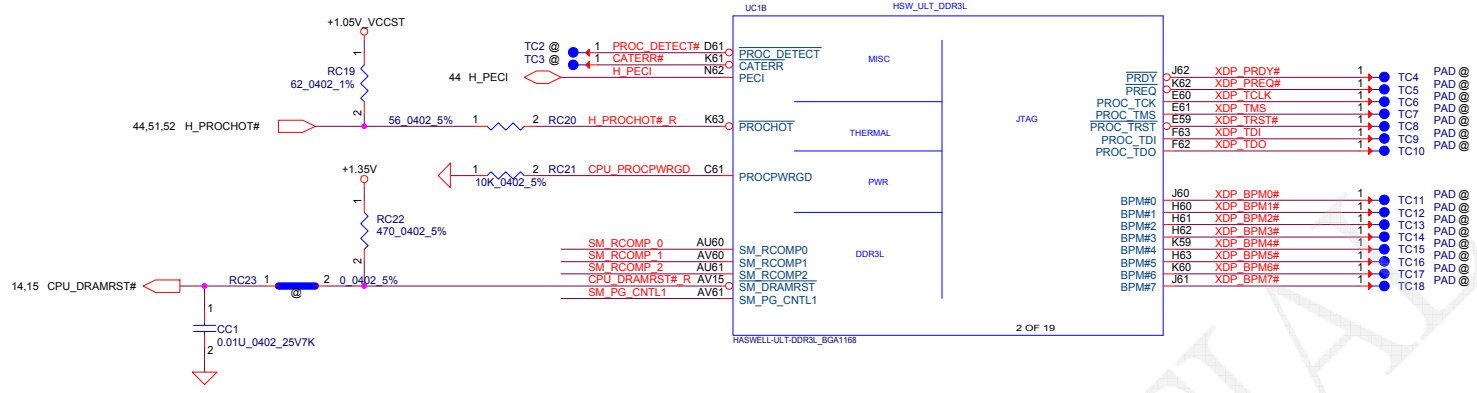

Security Classification	LC Future Center Secret Data		Title	MCP (MISC, THERMAL, JTAG) IGFC	
Issued Date	2013/08/08	Deciphered Date	2013/08/05	Size	Document Number
THIS SHEET OF ENGINEERING DRAWING IS THE PROPRIETARY PROPERTY OF LC FUTURE CENTER, AND CONTAINS CONFIDENTIAL AND TRADE SECRET INFORMATION. THIS SHEET MAY NOT BE TRANSFERRED FROM THE CUSTODY OF THE COMPETENT DIVISION OF R&D DEPARTMENT EXCEPT AS AUTHORIZED BY LC FUTURE CENTER. NEITHER THIS SHEET NOR THE INFORMATION IT CONTAINS MAY BE USED BY OR DISCLOSED TO ANY THIRD PARTY WITHOUT PRIOR WRITTEN CONSENT OF LC FUTURE CENTER.			ACL1 & ACL2		Rev 1.0
			Date:	Thursday, December 19, 2013	Sheet 5 of 59

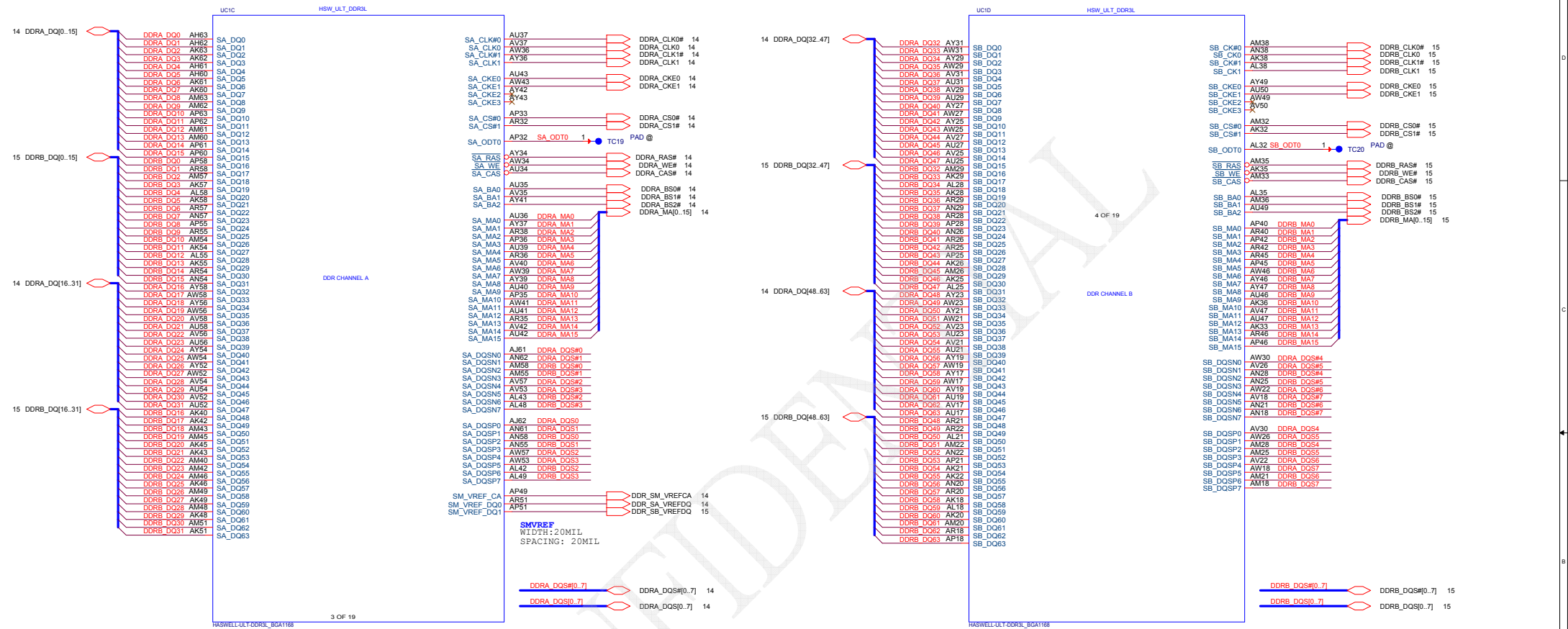

SMVREF
WIDTH: 2.0MIL
SPACING: 2.0MIL

Security Classification	LC Future Center Secret Data		Title	
Issued Date	2013/08/08	Deciphered Date	2013/08/05	
THIS SHEET OF ENGINEERING DRAWINGS IS THE PROPRIETARY PROPERTY OF LC FUTURE CENTER AND CONTAINS CONFIDENTIAL AND TRADE SECRET INFORMATION. THIS SHEET MAY NOT BE TRANSFERRED FROM THE CUSTODY OF THE COMPETENT DIVISION OF RAD DEPARTMENT EXCEPT AS AUTHORIZED BY LC FUTURE CENTER. NEITHER THIS SHEET NOR THE INFORMATION IT CONTAINS MAY BE USED BY OR DISCLOSED TO ANY THIRD PARTY WITHOUT PRIOR WRITTEN CONSENT OF LC FUTURE CENTER.				Size: Document Number Custom: ACLU1 & ACU2 Date: Thursday, December 19, 2013 Sheet 6 of 59

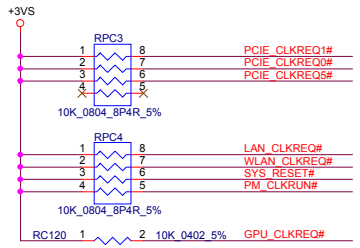

PCIE CLK2 LAN
PCIE CLK3 WLAN
PCIE CLK4 GPU

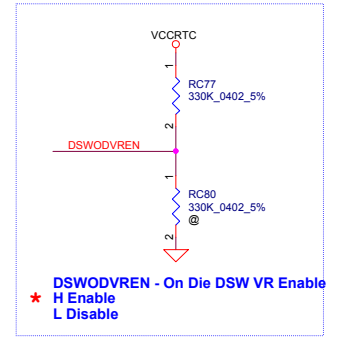
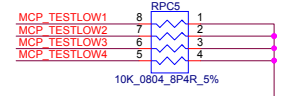
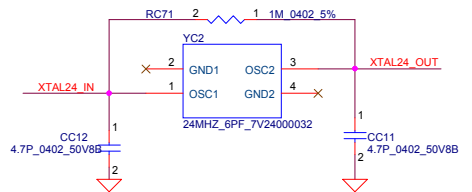
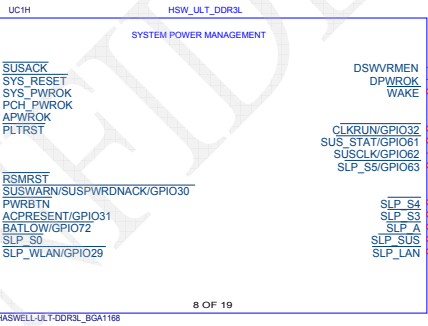
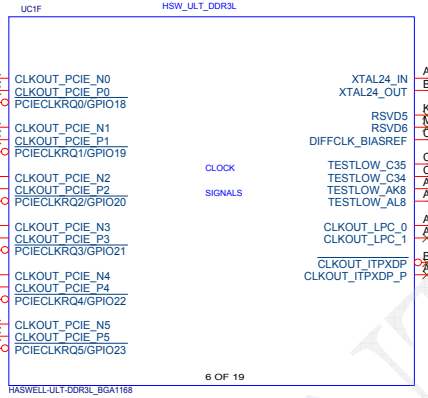
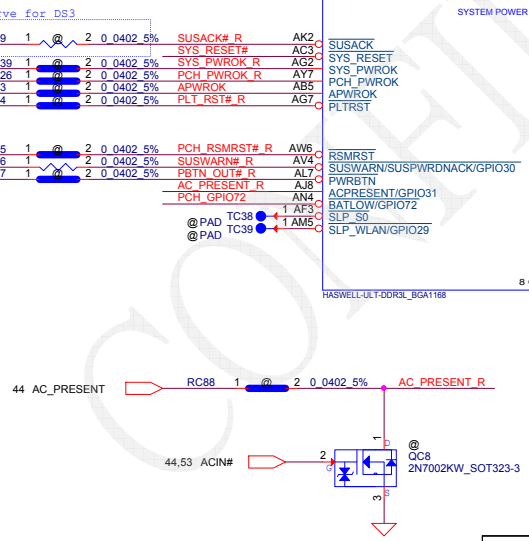
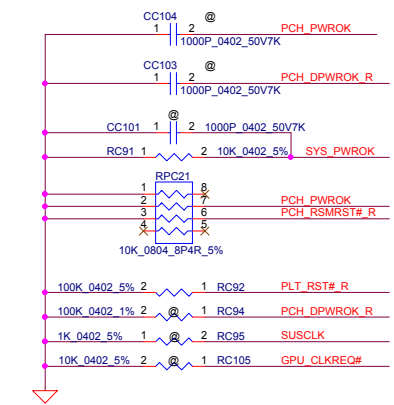
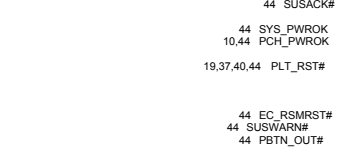
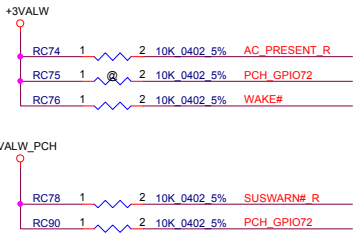

Security Classification	LC Future Center Secret Data	
Issued Date	2013/08/08	Deciphered Date 2013/08/05
THIS SHEET OF ENGINEERING DRAWING IS THE PROPRIETARY PROPERTY OF LC FUTURE CENTER AND CONTAINS CONFIDENTIAL AND TRADE SECRET INFORMATION. THIS SHEET MAY NOT BE TRANSFERRED FROM THE CUSTODY OF THE COMPETENT DIVISION OF R&D DEPARTMENT EXCEPT AS AUTHORIZED BY LC FUTURE CENTER. NEITHER THIS SHEET NOR THE INFORMATION IT CONTAINS MAY BE USED BY OR DISCLOSED TO ANY THIRD PARTY WITHOUT PRIOR WRITTEN CONSENT OF LC FUTURE CENTER.		

Title	MCP (Clock,PM)	
Size	Document Number	Rev 1.0
Custom	ACLU1 & ACLU2	
Date:	Thursday, December 19, 2013	Sheet 8 of 59

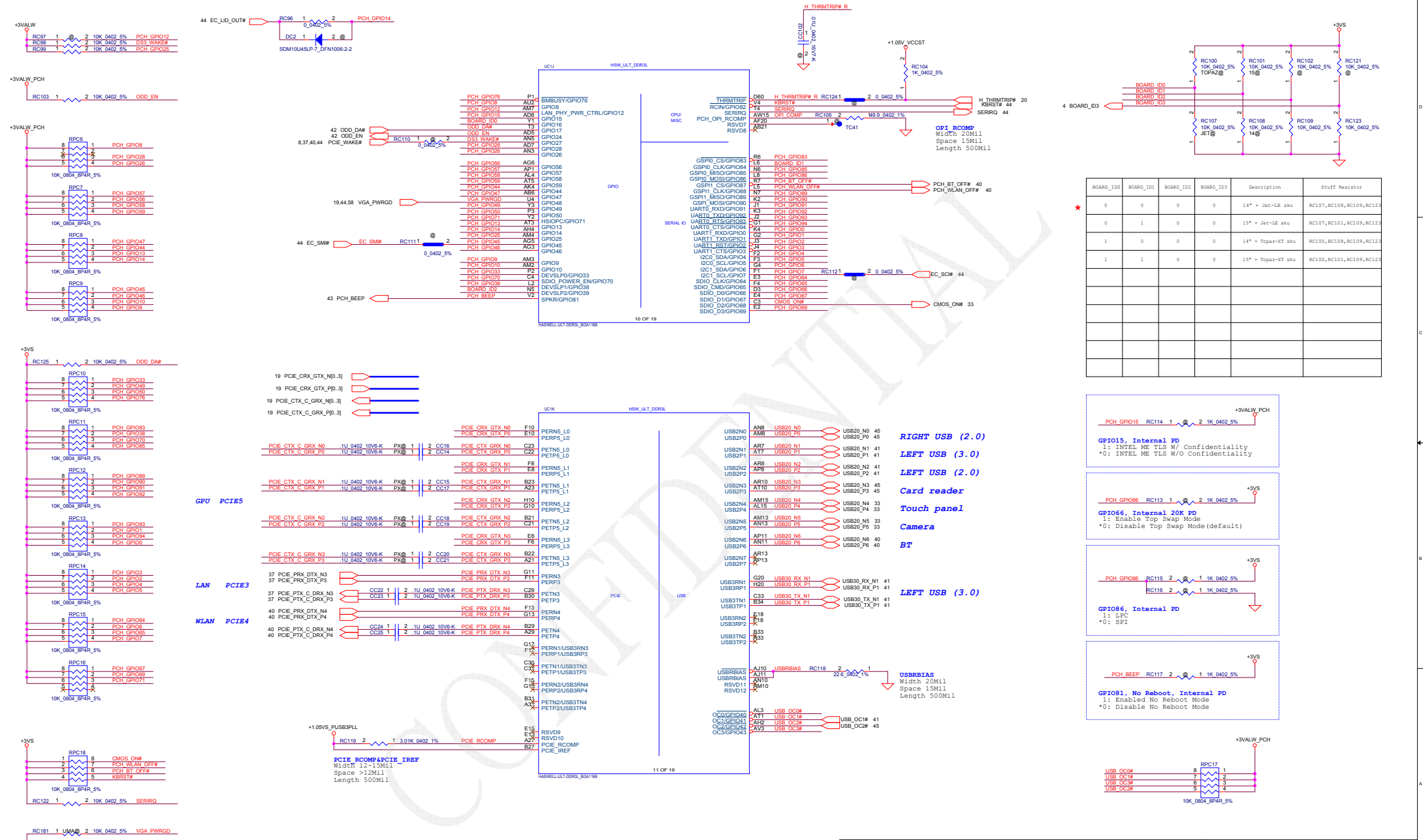

BOARD_ID0	BOARD_ID1	BOARD_ID2	BOARD_ID3	Description	Staff Resistor
0	0	0	0	14" + Jet-IE sku	RC107,RC108,RC109,RC113
0	0	0	0	10" + Jet-IE sku	RC107,RC109,RC109,RC113
1	0	0	0	14" + Topaz-XT sku	RC109,RC108,RC109,RC113
1	1	0	0	15" + Topaz-XT sku	RC109,RC101,RC109,RC113



GPIO15, Internal PD
 1: INTEL ME TLS W/ Confidentiality
 *0: INTEL ME TLS W/O Confidentiality



GPIO66, Internal 20K PD
 1: Enable Top Swap Mode
 *0: Disable Top Swap Mode (default)

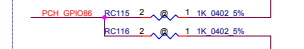

GPIO86, Internal PD
 1: I2C
 *0: SPI

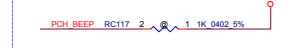

GPIO81, No Reboot, Internal PD
 1: Enabled No Reboot Mode
 *0: Disable No Reboot Mode



Security Classification	LC Future Center Secret Data		Title	MCP (GPIO,USB,PCIE)
Issued Date	2013/08/08	Deciphered Date	2013/08/05	
<small>THIS SHEET OF ENGINEERING DRAWING IS THE PROPRIETARY PROPERTY OF LC FUTURE CENTER, AND CONTAINS CONFIDENTIAL AND TRADE SECRET INFORMATION. THIS SHEET MAY NOT BE TRANSFERRED FROM THE CUSTODY OF THE COMPETENT DIVISION OF R&D DEPARTMENT EXCEPT AS AUTHORIZED BY LC FUTURE CENTER. NEITHER THIS SHEET NOR THE INFORMATION IT CONTAINS MAY BE USED BY OR DISCLOSED TO ANY THIRD PARTY WITHOUT PRIOR WRITTEN CONSENT OF LC FUTURE CENTER.</small>				
Size	Document Number	Rev		1.0
Custom	ACL11 & ACL12	Date		Thursday, December 19, 2013 Sheet 9 of 56

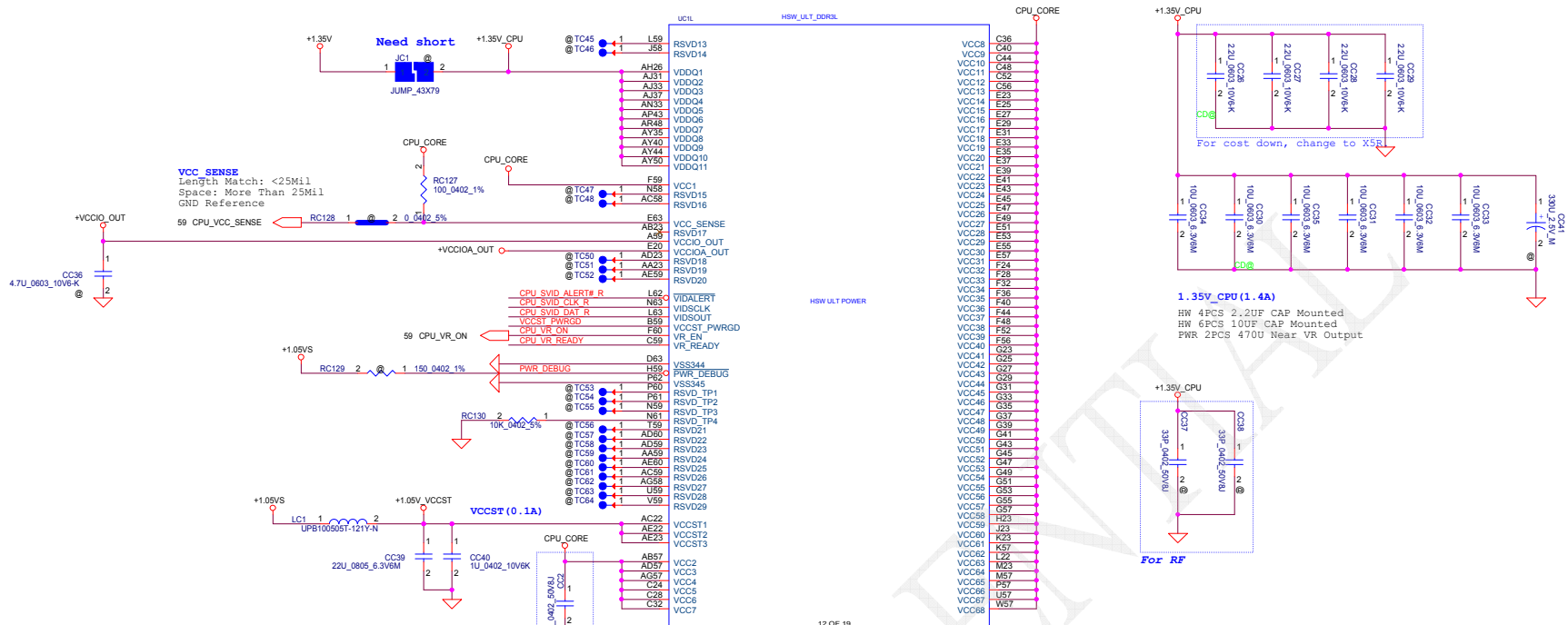

SVID
1, Stripline Line, No More Than 6000Mil
2, Alert# Route Between CLK and Data
3, CLK Length < Data Length < CLK Length + 2000Mil
4, Space at least 18Mil

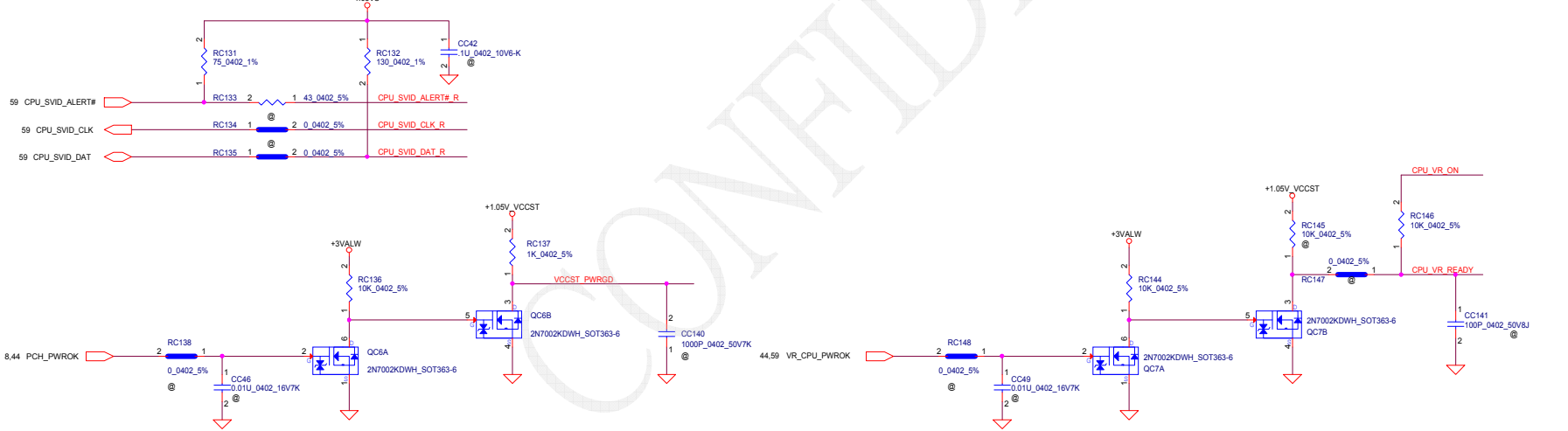

Security Classification	LC Future Center Secret Data		Title	
Issued Date	2013/08/08	Deciphered Date	2013/08/05	

THIS SHEET OF ENGINEERING DRAWING IS THE PROPRIETARY PROPERTY OF LC FUTURE CENTER, AND CONTAINS CONFIDENTIAL AND TRADE SECRET INFORMATION. THIS SHEET MAY NOT BE TRANSFERRED FROM THE CUSTODY OF THE COMPETENT DIVISION OF R&D DEPARTMENT EXCEPT AS AUTHORIZED BY LC FUTURE CENTER. PLEASE SIGN THE INFORMATION IT CONTAINS MAY BE USED BY OR DISCLOSED TO ANY THIRD PARTY WITHOUT PRIOR WRITTEN CONSENT OF LC FUTURE CENTER.

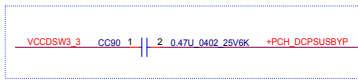
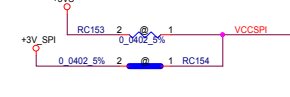
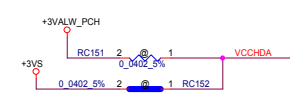
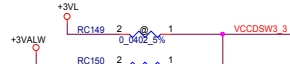
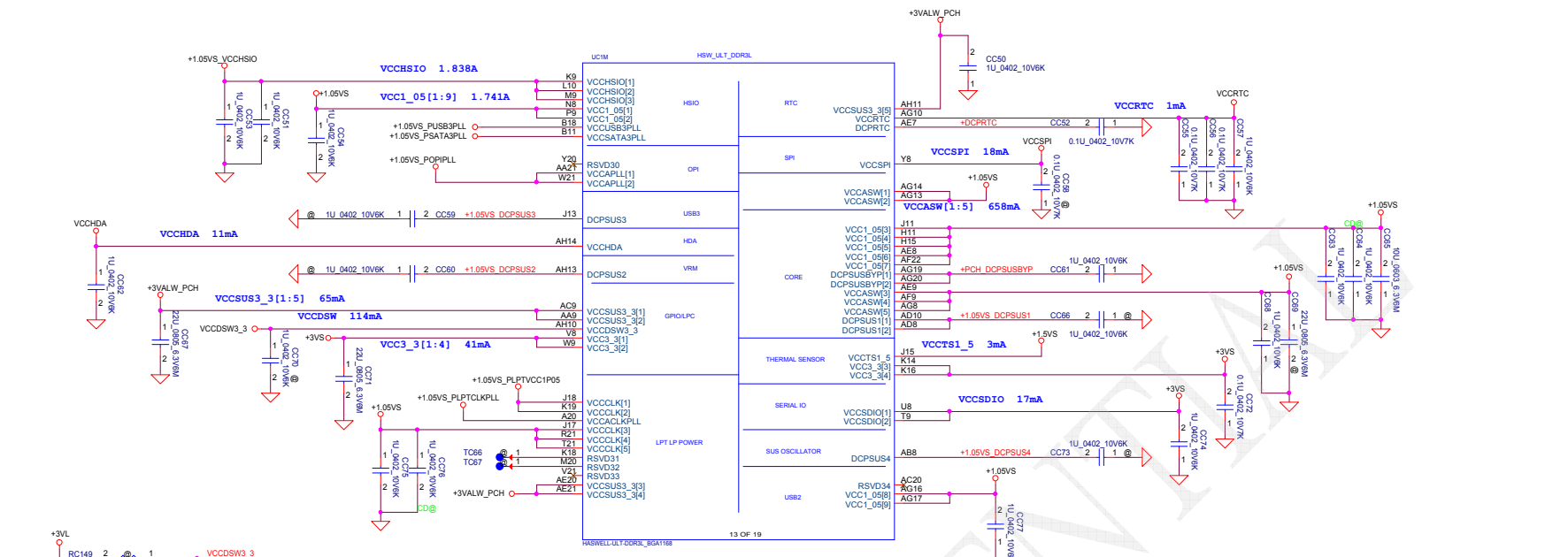

For Intel recommend, place one 0.47uF capacitor to address temporary inrush current. (DOC. 489999)

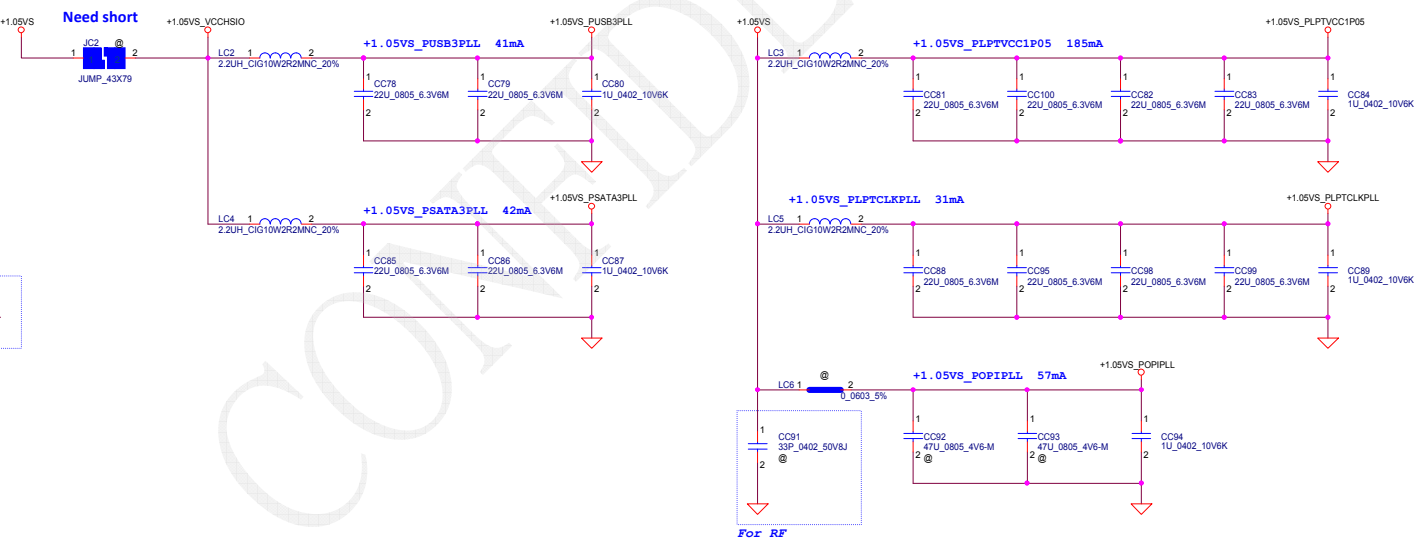

For RF

Security Classification	LC Future Center Secret Data		Title	MCP (Power2)	
Issued Date	2013/08/08	Deciphered Date	2013/08/05	Size	Document Number
THIS SHEET OF ENGINEERING DRAWING IS THE PROPRIETARY PROPERTY OF LC FUTURE CENTER. AND CONTAINS CONFIDENTIAL AND TRADE SECRET INFORMATION. THIS SHEET MAY NOT BE TRANSFERRED FROM THE CUSTODY OF THE COMPETENT DIVISION OF R&D DEPARTMENT EXCEPT AS AUTHORIZED BY LC FUTURE CENTER. NEITHER THIS SHEET NOR THE INFORMATION IT CONTAINS MAY BE USED BY OR DISCLOSED TO ANY THIRD PARTY WITHOUT PRIOR WRITTEN CONSENT OF LC FUTURE CENTER.				Custom	ACL01 & ACL02
Date:	Thursday, December 19, 2013	Sheet	11	of	50

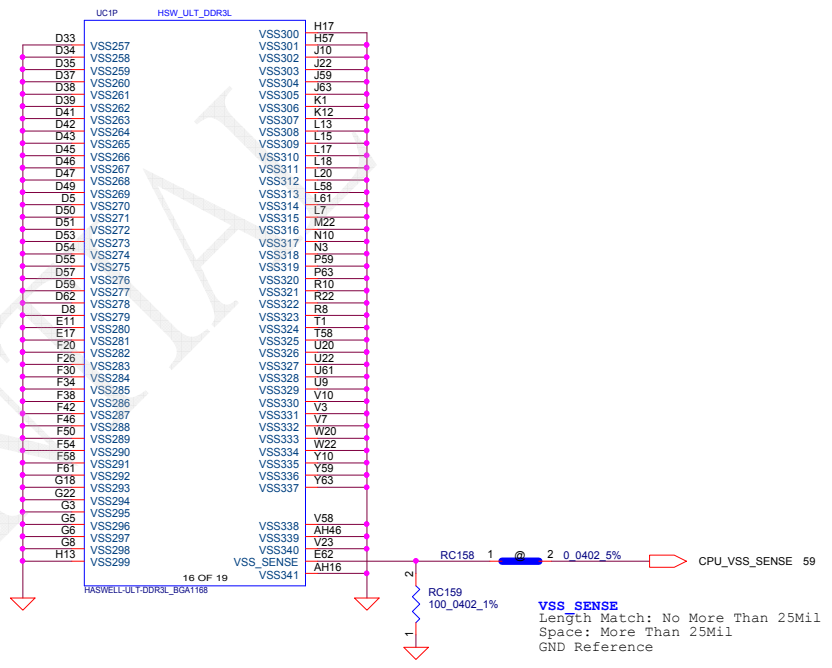
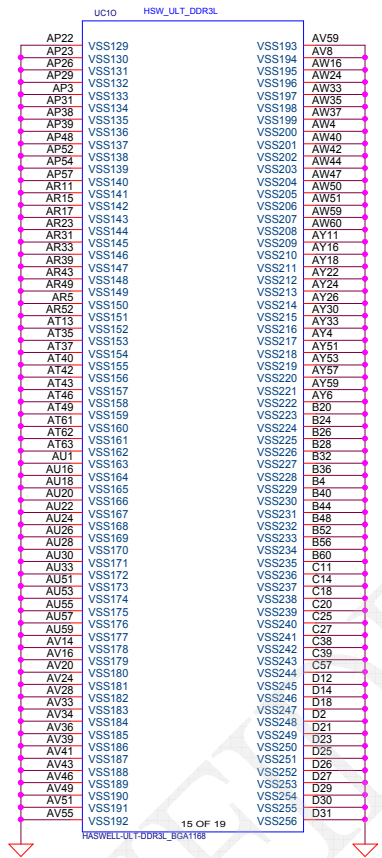
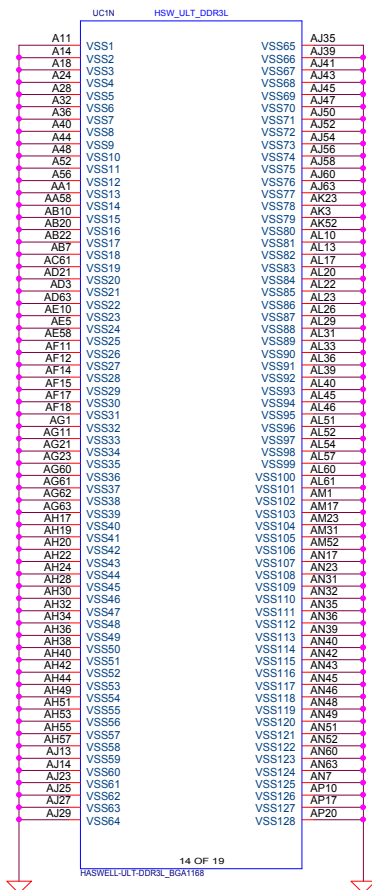

Security Classification				LC Future Center Secret Data		Title	
Issued Date	2013/08/08	Deciphered Date	2013/08/05	MCP (VSS)			
THIS SHEET OF ENGINEERING DRAWING IS THE PROPRIETARY PROPERTY OF LC FUTURE CENTER, AND CONTAINS CONFIDENTIAL AND TRADE SECRET INFORMATION. THIS SHEET MAY NOT BE TRANSFERRED FROM THE CUSTODY OF THE COMPETENT DIVISION OF R&D DEPARTMENT EXCEPT AS AUTHORIZED BY LC FUTURE CENTER. NEITHER THIS SHEET NOR THE INFORMATION IT CONTAINS MAY BE USED BY OR DISCLOSED TO ANY THIRD PARTY WITHOUT PRIOR WRITTEN CONSENT OF LC FUTURE CENTER.							
Size	Document Number	ACL1 & ACL2		Rev	1.0		
Date:	Thursday, December 19, 2013	Sheet	12	of	59		

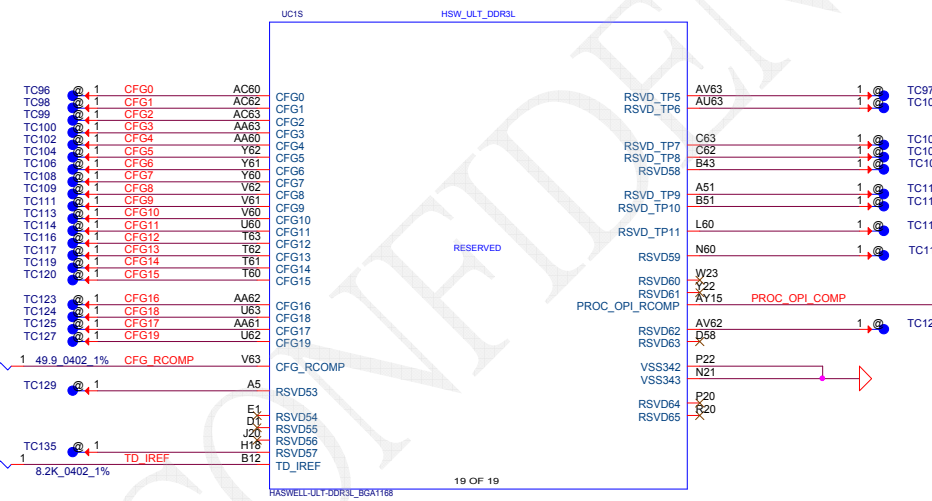
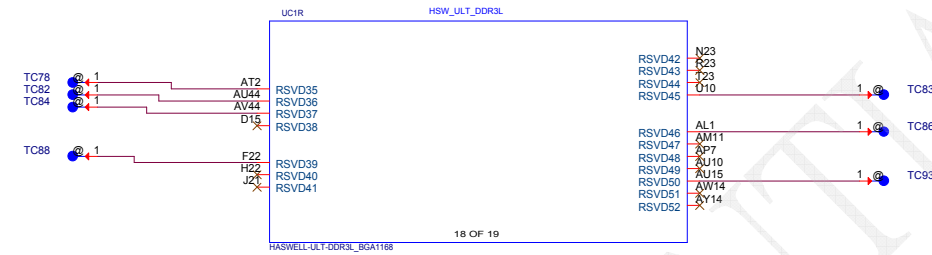
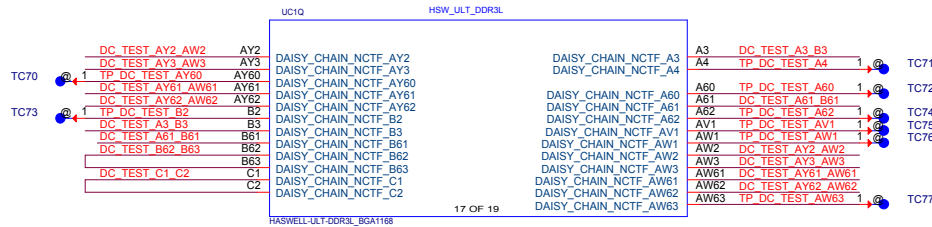

CFG_RCOMP&TD_IREF
Width 20Mil
Space 15Mil
Length 500Mil

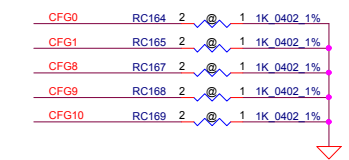
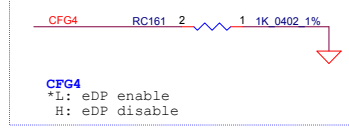
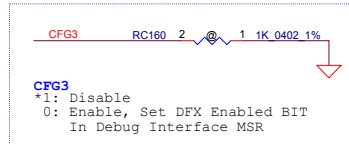

Security Classification		LC Future Center Secret Data	
Issued Date	2013/08/08	Deciphered Date	2013/08/05
THIS SHEET OF ENGINEERING DRAWING IS THE PROPRIETARY PROPERTY OF LC FUTURE CENTER AND CONTAINS CONFIDENTIAL AND TRADE SECRET INFORMATION. THIS SHEET MAY NOT BE TRANSFERRED FROM THE CUSTODY OF THE COMPETENT DIVISION OF R&T DEPARTMENT EXCEPT AS AUTHORIZED BY LC FUTURE CENTER NEITHER THIS SHEET NOR THE INFORMATION IT CONTAINS MAY BE USED BY OR DISCLOSED TO ANY THIRD PARTY WITHOUT PRIOR WRITTEN CONSENT OF LC FUTURE CENTER.			

Title		
MCP (OTHER)		
Size	Document Number	ACL01 & ACLU2
Custom		
Date:	Thursday, December 19, 2013	Sheet 13 of 59
Rev	1.0	

DDR3 SO-DIMM A

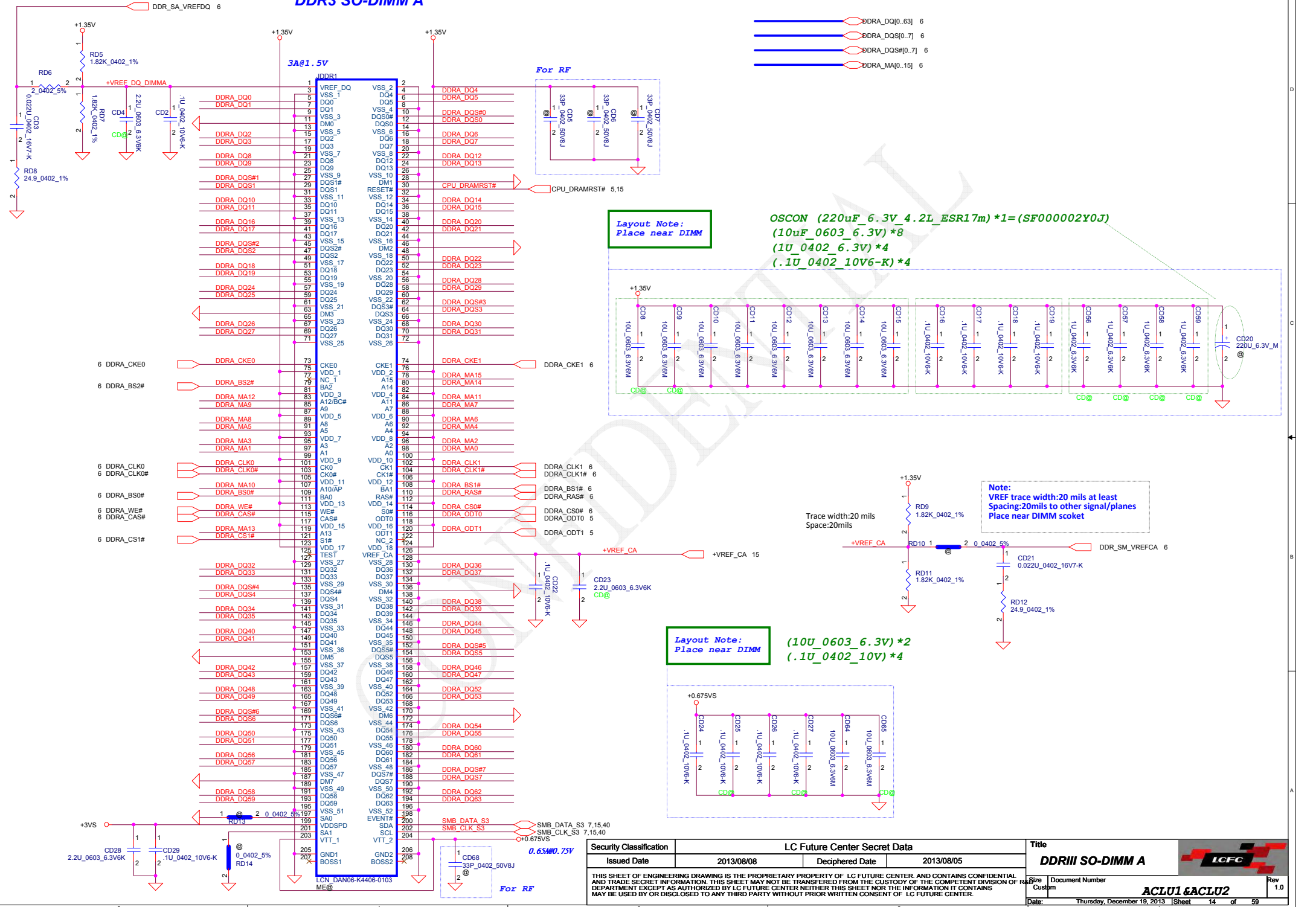

Security Classification	LC Future Center Secret Data		Title
Issued Date	2013/08/08	Deciphered Date	2013/08/05
			DDR3 SO-DIMM A
THIS SHEET OF ENGINEERING DRAWING IS THE PROPRIETARY PROPERTY OF LC FUTURE CENTER, AND CONTAINS CONFIDENTIAL AND TRADE SECRET INFORMATION. THIS SHEET MAY NOT BE TRANSFERRED FROM THE CUSTODY OF THE COMPETENT DIVISION OF DEPARTMENT EXCEPT AS AUTHORIZED BY LC FUTURE CENTER. NEITHER THIS SHEET NOR THE INFORMATION IT CONTAINS MAY BE USED BY OR DISCLOSED TO ANY THIRD PARTY WITHOUT PRIOR WRITTEN CONSENT OF LC FUTURE CENTER.			Document Number Custom ACLU1 & ACLU2 Date: Thursday, December 19, 2013 Sheet 14 of 59

DDR3 SO-DIMM B

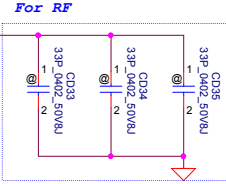
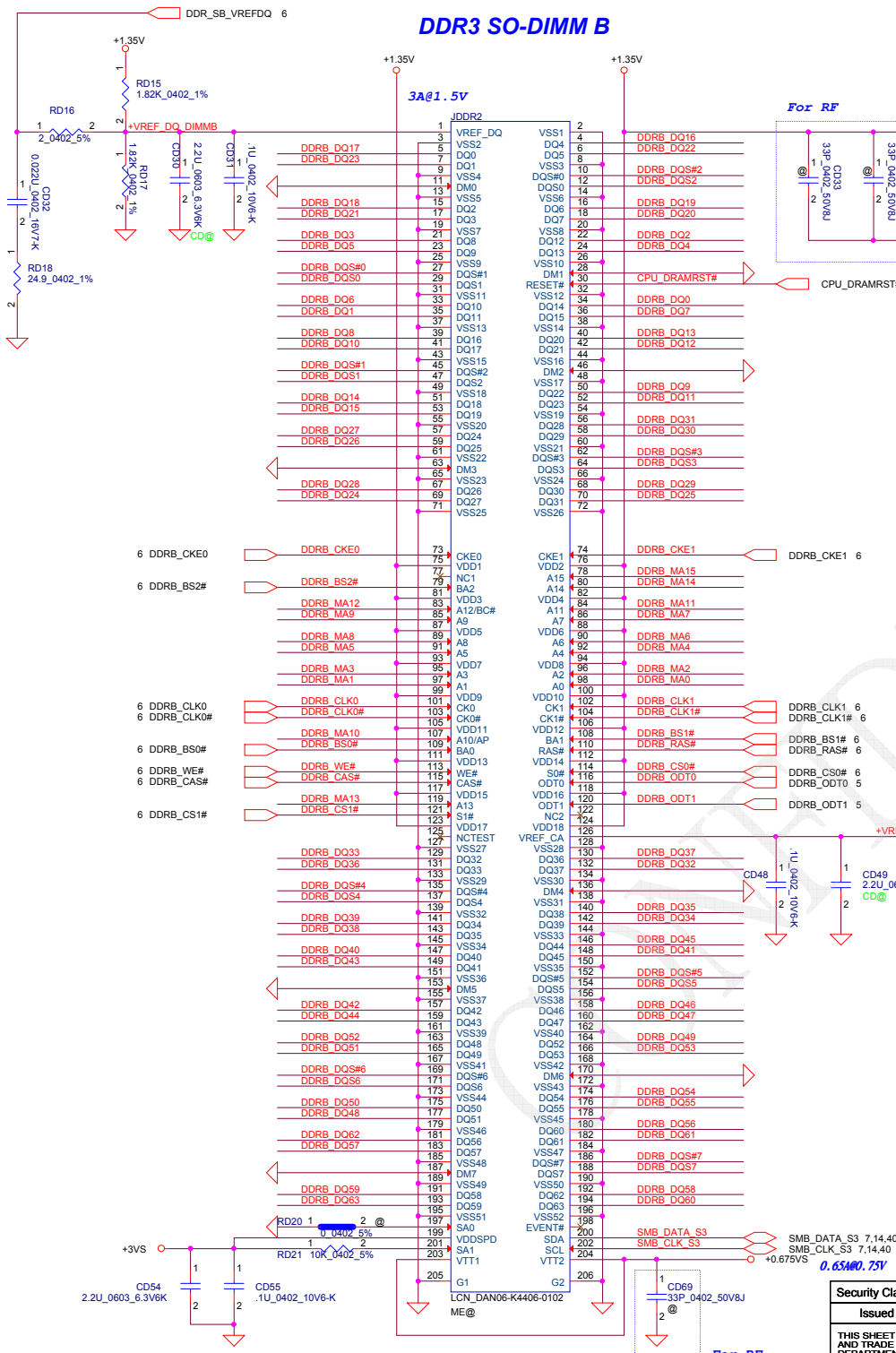

Layout Note:
Place near DIMM

(10uF_0603_6.3V)*8
(1U_0402_6.3V)*8
(.1U_0402_10V6-K)*4

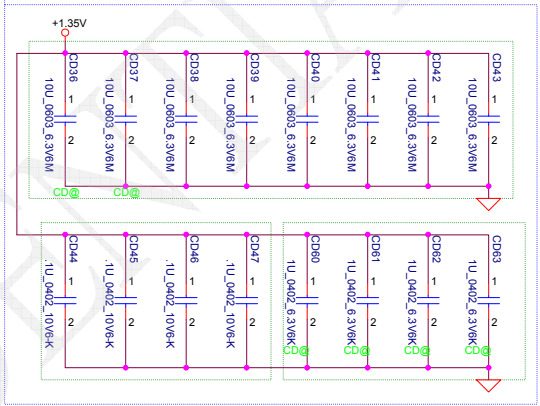

Layout Note:
Place near DIMM

(10U_0603_6.3V)*2
(.1U_0402_10V)*4

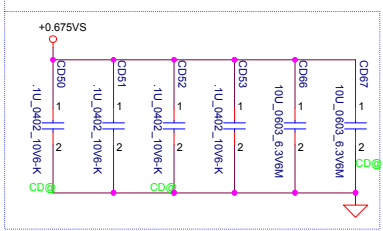

Swap Table

Pin Number	Pin Name	Net Name
5	DQ0	DDR8_DQ17
7	DQ1	DDR8_DQ23
15	DQ2	DDR8_DQ18
17	DQ3	DDR8_DQ21
4	DQ4	DDR8_DQ16
6	DQ5	DDR8_DQ22
16	DQ6	DDR8_DQ19
18	DQ7	DDR8_DQ20
10	DQS#0	DDR8_DQS#2
12	DQS0	DDR8_DQS2
21	DQ8	DDR8_DQ3
23	DQ9	DDR8_DQ5
33	DQ10	DDR8_DQ6
35	DQ11	DDR8_DQ1
22	DQ12	DDR8_DQ2
24	DQ13	DDR8_DQ4
34	DQ14	DDR8_DQ0
36	DQ15	DDR8_DQ7
27	DQS#1	DDR8_DQS#0
29	DQS1	DDR8_DQS0
39	DQ16	DDR8_DQ8
41	DQ17	DDR8_DQ10
51	DQ18	DDR8_DQ14
53	DQ19	DDR8_DQ15
40	DQ20	DDR8_DQ13
42	DQ21	DDR8_DQ12
50	DQ22	DDR8_DQ9
52	DQ23	DDR8_DQ11
45	DQS#2	DDR8_DQS#1
47	DQS2	DDR8_DQS1
57	DQ24	DDR8_DQ27
59	DQ25	DDR8_DQ26
67	DQ26	DDR8_DQ28
69	DQ27	DDR8_DQ24
56	DQ28	DDR8_DQ31
58	DQ29	DDR8_DQ30
68	DQ30	DDR8_DQ29
70	DQ31	DDR8_DQ25
62	DQS#3	DDR8_DQS#3
64	DQS3	DDR8_DQS3
129	DQ32	DDR8_DQ33
131	DQ33	DDR8_DQ36
141	DQ34	DDR8_DQ39
143	DQ35	DDR8_DQ38
130	DQ36	DDR8_DQ37
132	DQ37	DDR8_DQ32
140	DQ38	DDR8_DQ35
142	DQ39	DDR8_DQ34
135	DQS#4	DDR8_DQS#4
137	DQS4	DDR8_DQS4
147	DQ40	DDR8_DQ40
149	DQ41	DDR8_DQ43
157	DQ42	DDR8_DQ42
159	DQ43	DDR8_DQ44
146	DQ44	DDR8_DQ45
148	DQ45	DDR8_DQ41
158	DQ46	DDR8_DQ46
160	DQ47	DDR8_DQ47
152	DQS#5	DDR8_DQS#5
154	DQS5	DDR8_DQS5
163	DQ48	DDR8_DQ52
165	DQ49	DDR8_DQ51
175	DQ50	DDR8_DQ50
177	DQ51	DDR8_DQ48
164	DQ52	DDR8_DQ49
166	DQ53	DDR8_DQ53
174	DQ54	DDR8_DQ54
176	DQ55	DDR8_DQ55
169	DQS#6	DDR8_DQS#6
171	DQS6	DDR8_DQS6
181	DQ56	DDR8_DQ62
183	DQ57	DDR8_DQ57
191	DQ58	DDR8_DQ59
193	DQ59	DDR8_DQ63
180	DQ60	DDR8_DQ56
182	DQ61	DDR8_DQ61
192	DQ62	DDR8_DQ58
194	DQ63	DDR8_DQ60
186	DQS#7	DDR8_DQS#7
188	DQS7	DDR8_DQS7

Security Classification	LC Future Center Secret Data		
Issued Date	2013/08/08	Deciphered Date	2013/08/05
THIS SHEET OF ENGINEERING DRAWING IS THE PROPRIETARY PROPERTY OF LC FUTURE CENTER, AND CONTAINS CONFIDENTIAL AND TRADE SECRET INFORMATION. THIS SHEET MAY NOT BE TRANSFERRED FROM THE CUSTODY OF THE COMPETENT DIVISION OF DEPARTMENT EXCEPT AS AUTHORIZED BY LC FUTURE CENTER. NEITHER THIS SHEET NOR THE INFORMATION IT CONTAINS MAY BE USED BY OR DISCLOSED TO ANY THIRD PARTY WITHOUT PRIOR WRITTEN CONSENT OF LC FUTURE CENTER.			

Title	DDR3 SO-DIMM B		
Document Number	ACLU1 & ACLU2		
Date	Thursday, December 19, 2013	Sheet	15 of 59

CONFIDENTIAL

Security Classification	LC Future Center Secret Data		Title	
Issued Date	2013/08/08	Deciphered Date	2013/08/05	
THIS SHEET OF ENGINEERING DRAWING IS THE PROPRIETARY PROPERTY OF LC FUTURE CENTER, AND CONTAINS CONFIDENTIAL AND TRADE SECRET INFORMATION. THIS SHEET MAY NOT BE TRANSFERRED FROM THE CUSTODY OF THE COMPETENT DIVISION OF R&D DEPARTMENT EXCEPT AS AUTHORIZED BY LC FUTURE CENTER. NEITHER THIS SHEET NOR THE INFORMATION IT CONTAINS MAY BE USED BY OR DISCLOSED TO ANY THIRD PARTY WITHOUT PRIOR WRITTEN CONSENT OF LC FUTURE CENTER.				
Size	Custom	Document Number	ACL01 & ACL02	Rev 1.0
Date:	Thursday, December 19, 2013		Sheet 16	of 59

CONFIDENTIAL

Security Classification	LC Future Center Secret Data		Title			
Issued Date	2013/08/08	Deciphered Date	2013/08/05		Blank	
THIS SHEET OF ENGINEERING DRAWING IS THE PROPRIETARY PROPERTY OF LC FUTURE CENTER, AND CONTAINS CONFIDENTIAL AND TRADE SECRET INFORMATION. THIS SHEET MAY NOT BE TRANSFERRED FROM THE CUSTODY OF THE COMPETENT DIVISION OF R&D DEPARTMENT EXCEPT AS AUTHORIZED BY LC FUTURE CENTER. NEITHER THIS SHEET NOR THE INFORMATION IT CONTAINS MAY BE USED BY OR DISCLOSED TO ANY THIRD PARTY WITHOUT PRIOR WRITTEN CONSENT OF LC FUTURE CENTER.				Size Custom	Document Number ACL01 & ACL02	Rev 1.0
				Date:	Thursday, December 19, 2013	Sheet 17 of 59

Power-Up/Down Sequence

"Topaz" has the following requirements with regards to power-supply sequencing to avoid damaging the ASIC:

All the ASIC supplies must reach their respective nominal voltages within 20 ms of the start of the ramp-up sequence, though a shorter ramp-up duration is preferred. The maximum slew rate on all rails is 50 mV/μs.

It is recommended that the 3.3-V rail ramp up first. The 3.3-V, 1.8-V, and 0.95-V rails must reach their ready state at least 10 μs before VDDC, VDDCI, and VMEMIO start to ramp up.

The power rails that are shared with other components on the system should be gated for the dGPU so that when the dGPU is powered down (for example AMD PowerXpress idle state), all the power rails are removed from the dGPU. The gate circuits must meet the slew rate requirement (such as ≤ 50 mV/μs).

For power down, reversing the ramp-up sequence is recommended.

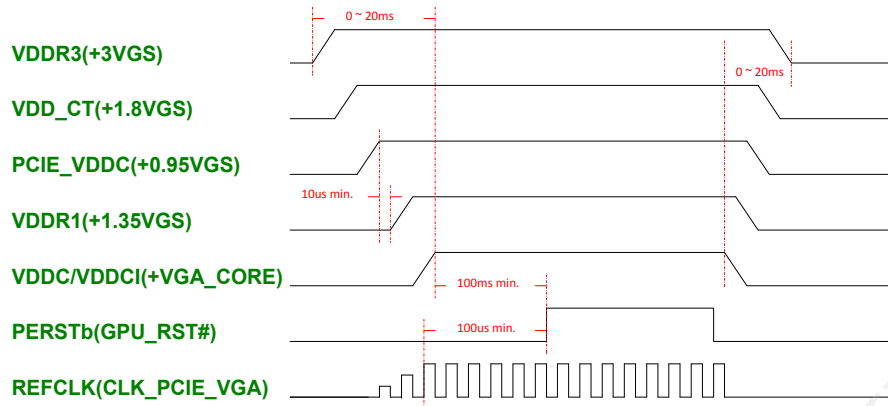

CONFIGURATION STRAPS ALLOW FOR PULLUP PADS FOR THESE STRAPS AND IF THESE GPIOs ARE USED, THEY MUST NOT CONFLICT DURING RESET

RECOMMENDED SETTINGS
0= DO NOT INSTALL RESISTOR
1= INSTALL 10K RESISTOR
X = DESIGN DEPENDANT
NA = NOT APPLICABLE

MLPS Bit	Strap Name	Description	RECOMMENDED SETTINGS
PS_0[1] PS_0[2] PS_0[3]	ROM_CONFIG[0] ROM_CONFIG[1] ROM_CONFIG[2]	Define the ROM type when STRAP_BIOS_ROM_EN = 1. Define the primary memory-aperture size when STRAP_BIOS_ROM_EN = 0. 100 = 256MB	X
PS_0[4]	N/A	Reserved for internal use only. Must be 1 at reset.	1
PS_0[5]	AUD_PORT_CONN_PINSTRAP[0]	The LSB (least significant bit) of the strap option that indicates the number of audio-capable display outputs.	1
PS_1[1]	STRAP_BIF_GEN3_EN_A	1 = PCIe GEN3 is supported. 0 = PCIe GEN3 is not supported. 0= Not support	X
PS_1[2]	STRAP_BIF_CLK_PM_EN	0 = The CLKREQB power management capability is disabled 1 = The CLKREQB power management capability is enabled	0
PS_1[3]	N/A	Reserved for internal use only. Must be 0 at reset.	0
PS_1[4]	STRAP_TX_CFG_DRV_FULL_SWING	0 = The transmitter half-swing is enabled 1 = The transmitter full-swing is enabled	1
PS_1[5]	STRAP_TX_DEEMPH_EN	0 = Tx deemphasis disabled. 1 = Tx deemphasis enabled. 1= Enable	X
PS_2[1]	N/A	Reserved.	0
PS_2[2]	N/A	Reserved.	0
PS_2[3]	STRAP_BIOS_ROM_EN	0 = Disable the external BIOS ROM device. 1 = Enable the external BIOS ROM device. 0= Disable	X
PS_2[4]	STRAP_BIF_VGA_DIS	0 = VGA controller capacity enabled. 1 = The device will not be recognized as the system's VGA controller.	1
PS_2[5]	N/A	Reserved	1
PS_3[1] PS_3[2] PS_3[3]	BOARD_CONFIG[0] BOARD_CONFIG[1] BOARD_CONFIG[2]	Board configuration related strapping, such as for memory ID 000 = Hynix 256M*16 001 = Hynix 128M*16 100 = Samsung 256M*16 011 = Samsung 128M*16 010 = Micron 256M*16 111 = Micron 128M*16	X
PS_3[4] PS_3[5]	AUD_PORT_CONN_PINSTRAP[1] AUD_PORT_CONN_PINSTRAP[2]	Determines the maximum number of digital display audio endpoints that will be presented to the OS and user.(Combine with PS_0[5]) 111 = No usable endpoints. 110 = One usable endpoint. 101 = Two usable endpoints. 100 = Three usable endpoints. 011 = Four usable endpoints. 010 = Five usable endpoints. 001 = Six usable endpoints. 000 = All endpoints are usable.	11

VRAM ID config

Memory Type		VRAM ID PS_3[3:1]	PU resistor RV33	PD resistor RV36
128Mx16	Hynix H5TC2G63FFR-11C	100	4.53K	4.99K
	Micron MT41J128M16JT-093G	111	4.75K	NC
	Samsung K4W2G1646Q-BC1A	110	3.4K	10K
256Mx16	Hynix H5TC4G63AFR-11C	000	NC	4.75K
	Micron MT41J256M16HA-093G	010	4.53K	2K
	Samsung K4W4G1646D-BC1A	001	8.45K	2K
	Micron MT41K256M16HA-107G	011	6.98K	4.99K

Security Classification		LC Future Center Secret Data		Title	
Issued Date	2013/08/08	Deciphered Date	2013/08/05	VGA Notes List	
THIS SHEET OF ENGINEERING DRAWING IS THE PROPRIETARY PROPERTY OF LC FUTURE CENTER, AND CONTAINS CONFIDENTIAL AND TRADE SECRET INFORMATION. THIS SHEET MAY NOT BE TRANSFERRED FROM THE CUSTODY OF THE COMPETENT DIVISION OF R&D DEPARTMENT EXCEPT AS AUTHORIZED BY LC FUTURE CENTER. NEITHER THIS SHEET NOR THE INFORMATION IT CONTAINS MAY BE USED BY OR DISCLOSED TO ANY THIRD PARTY WITHOUT PRIOR WRITTEN CONSENT OF LC FUTURE CENTER.				Size	Document Number
				Customer	ACLU1 & ACLU2
				Date:	Thursday, December 19, 2013 Sheet 18 of 59

9 PCIe_CTX_C_GRX_P[3..0] PCIe_CTX_C_GRX_P[3..0]
 9 PCIe_CTX_C_GRX_N[3..0] PCIe_CTX_C_GRX_N[3..0]

PCIE_CRX_GTX_P[3..0] PCIe_CRX_GTX_P[3..0] 9
 PCIe_CRX_GTX_N[3..0] PCIe_CRX_GTX_N[3..0] 9

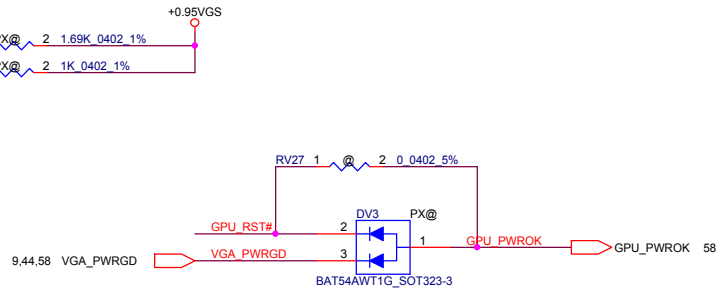
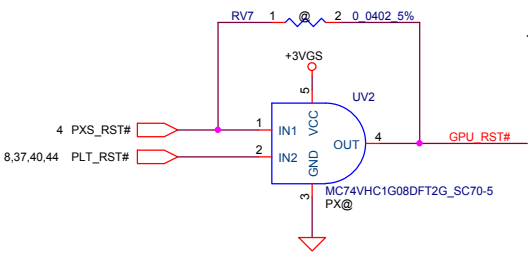
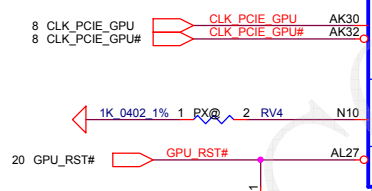
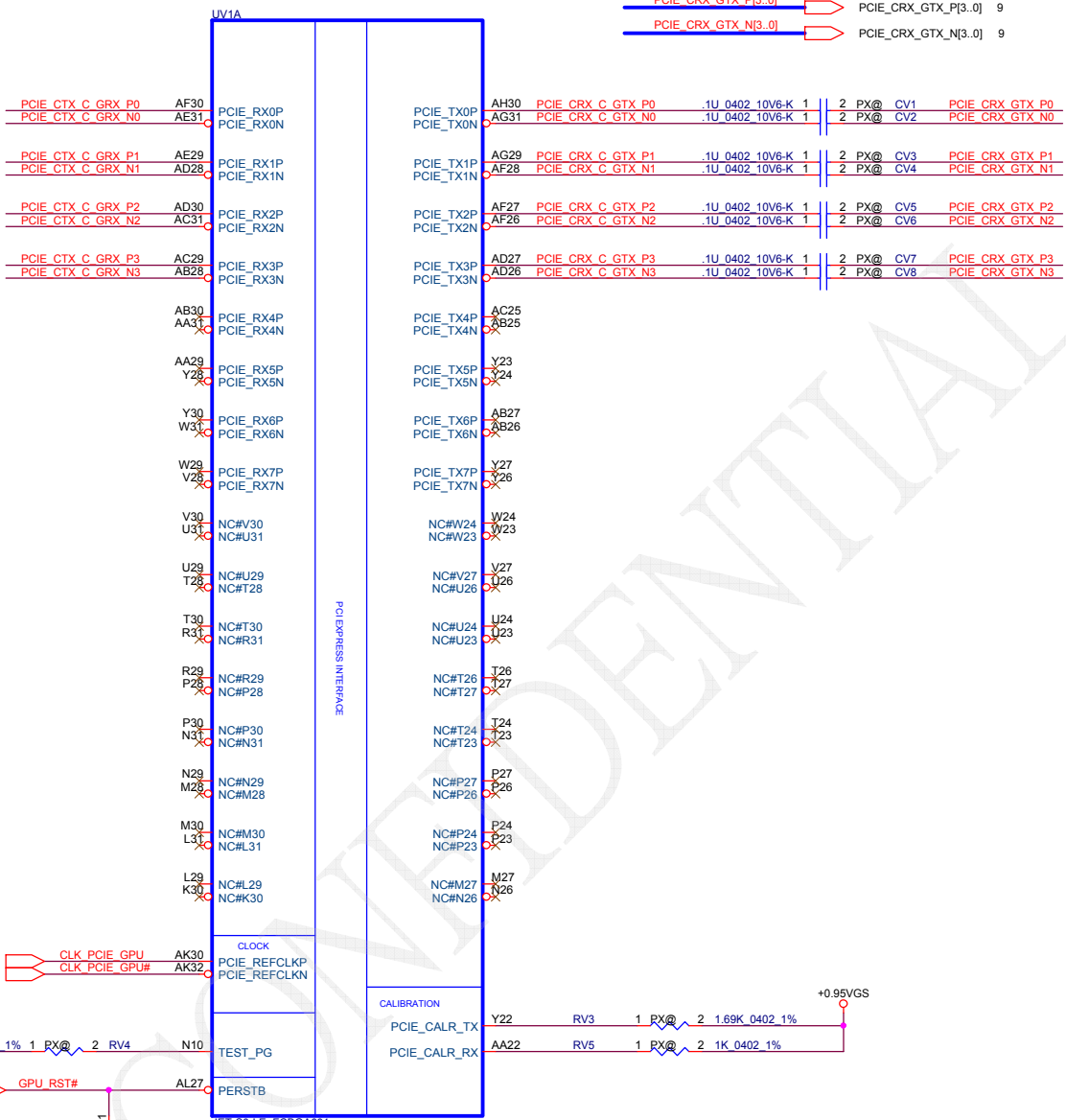

Security Classification		LC Future Center Secret Data	
Issued Date	2013/08/08	Deciphered Date	2013/08/05
THIS SHEET OF ENGINEERING DRAWING IS THE PROPRIETARY PROPERTY OF LC FUTURE CENTER, AND CONTAINS CONFIDENTIAL AND TRADE SECRET INFORMATION. THIS SHEET MAY NOT BE TRANSFERRED FROM THE CUSTODY OF THE COMPETENT DIVISION OF R&D DEPARTMENT EXCEPT AS AUTHORIZED BY LC FUTURE CENTER NEITHER THIS SHEET NOR THE INFORMATION IT CONTAINS MAY BE USED BY OR DISCLOSED TO ANY THIRD PARTY WITHOUT PRIOR WRITTEN CONSENT OF LC FUTURE CENTER.			

Title		
ATI_JET-LE_PCIE		
Size A3	Document Number	Rev 1.0
Date: Thursday, December 19, 2013		Sheet 19 of 59

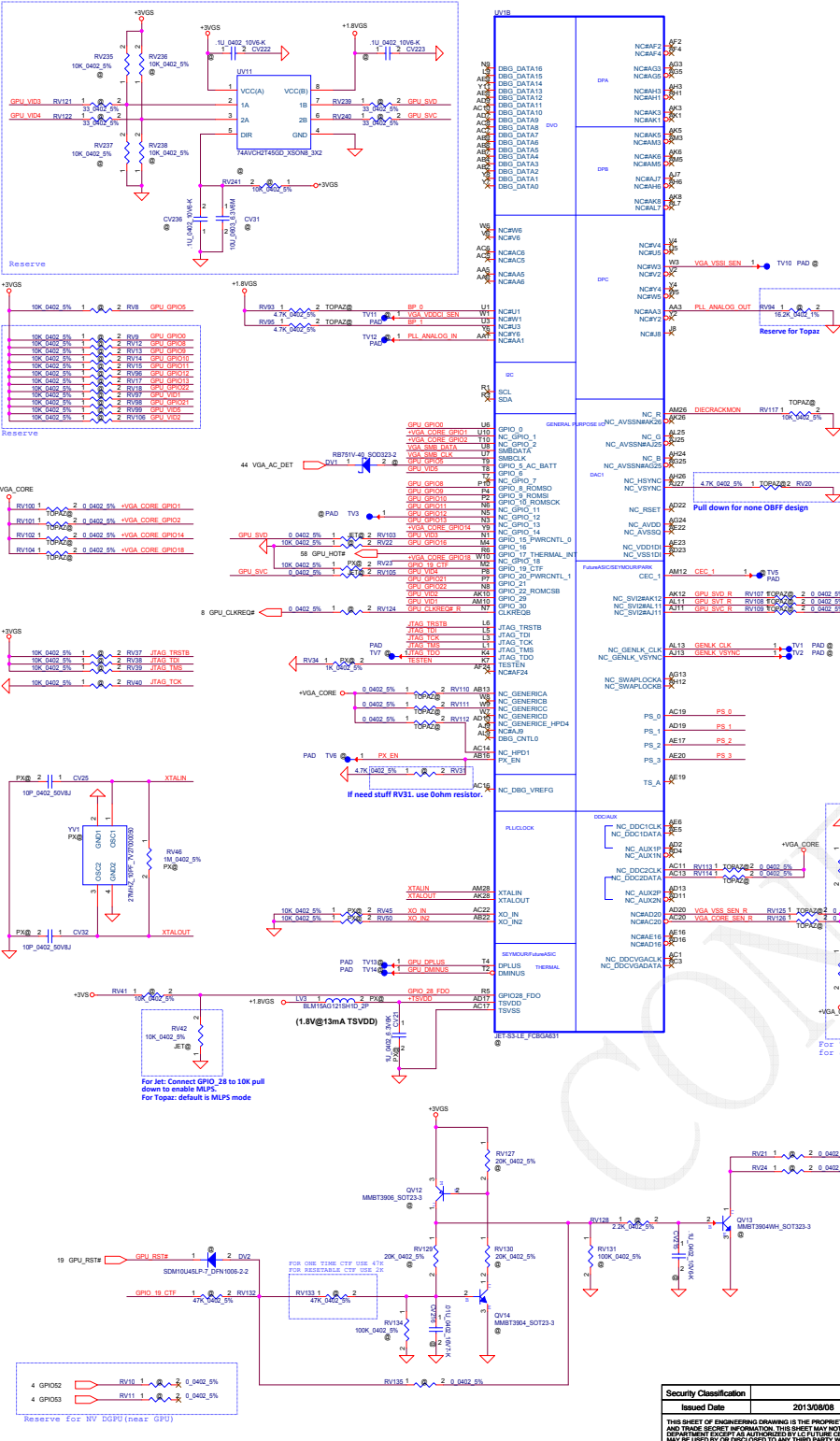

CONFIGURATION STRAPS
 ALLOW FOR PULLUP PADS FOR THESE STRAPS AND IF THESE GPIOs ARE USED, THEY MUST NOT CONFLICT DURING RESET

MIPS Bit	Strap Name	Description	RECOMMENDED SETTINGS
PS_0[0]	ROM_CONFIG[0]	Define the ROM type when STRAP_BIOS_ROM_EN = 1	X
PS_0[1]	ROM_CONFIG[1]	Define the primary memory aperture size when STRAP_BIOS_ROM_EN = 0.	100 = 256MB
PS_0[6]	N/A	Reserved for internal use only. Must be 0 at reset.	1
PS_0[9]	AUD_PORT_CONN_PINSTRAP[0]	The LSB (least significant bit) of the strap option that indicates the number of auto-capable display outputs.	1
PS_1[10]	STRAP_BIF_GEN3_EN_A	1 = PCIe GEN3 is supported 0 = PCIe GEN3 is not supported.	On Not support
PS_1[12]	STRAP_BIF_CLK_PM_EN	0 = The CLKREQ power management capability is disabled 1 = The CLKREQ power management capability is enabled.	0
PS_1[13]	N/A	Reserved for internal use only. Must be 0 at reset.	0
PS_1[14]	STRAP_TX_CPD_DRV_FULL_SWING	0 = The transmitter full-swing is enabled 1 = The transmitter full-swing is disabled.	1
PS_1[18]	STRAP_TX_DEEMPH_EN	0 = Tx deemphasis disabled 1 = Tx deemphasis enabled.	1 Enable
PS_2[0]	N/A	Reserved.	0
PS_2[3]	STRAP_BIOS_ROM_EN	1 = Disable the external BIOS ROM device. 0 = Enable the external BIOS ROM device.	On Disable
PS_2[4]	STRAP_BIF_VGA_DIS	0 = VGA controller capacity enabled. 1 = The device will not be recognized as the system's VGA controller.	1
PS_2[8]	N/A	Reserved.	1
PS_3[1]	BOARD_CONFIG[0]	Board configuration related strap, such as for memory ID	X
PS_3[2]	BOARD_CONFIG[1]	00 = Hynix 55M16 01 = Hynix 128M16 02 = Samsung 25M16 03 = Samsung 25M16 04 = Micron 25M16 05 = Micron 25M16	00 = Hynix 55M16 01 = Hynix 128M16 02 = Samsung 25M16 03 = Samsung 25M16 04 = Micron 25M16 05 = Micron 25M16
PS_3[3]	BOARD_CONFIG[2]	0 = No usable endpoints. 1 = One usable endpoint. 2 = Two usable endpoints. 3 = Three usable endpoints. 4 = Four usable endpoints. 5 = Five usable endpoints. 6 = Six usable endpoints. 7 = Seven usable endpoints.	11 = No usable endpoints.
PS_3[4]	AUD_PORT_CONN_PINSTRAP[1]	Determines the maximum number of digital display auto endpoints that will be presented to the OS and user (conform with PS_0[9]).	11
PS_3[5]	AUD_PORT_CONN_PINSTRAP[2]	Determines the maximum number of digital display auto endpoints that will be presented to the OS and user (conform with PS_0[9]).	11

SVC	SVD	Output Voltage (V)
0	0	1.1
0	1	1.0
1	0	0.9
1	1	0.8

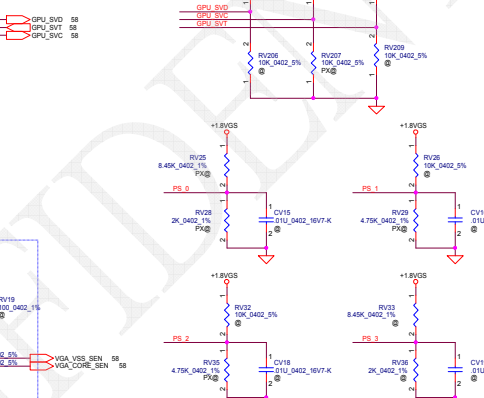

Capacitor Value (nF)	Bits [5:4]
680	00
82	01
10	10
NC	11

R_pu (Ω)	R_pd (Ω)	Bits [3:1]
NC	4750	000
8450	2000	001
4530	2000	010
6980	4900	011
4530	4900	100
3240	5620	101
3400	10000	110
4750	NC	111

Note: 0402 1% resistors are required.

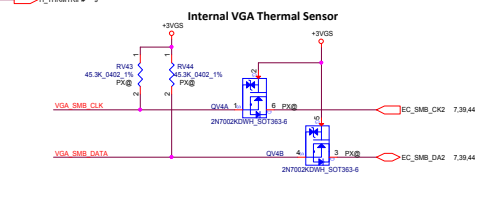

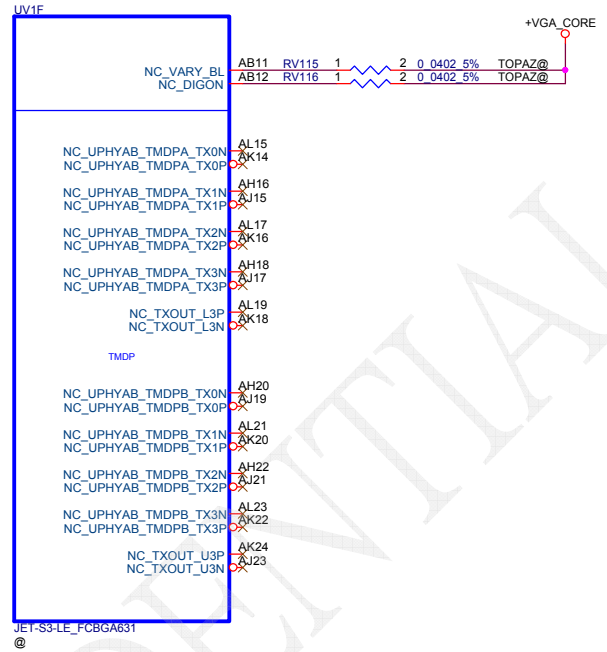

Security Classification		LC Future Center Secret Data		Title	
Issued Date	2013/08/08	Deciphered Date	2013/08/05	ATI_JET-LE_TMDP	
THIS SHEET OF ENGINEERING DRAWING IS THE PROPRIETARY PROPERTY OF LC FUTURE CENTER. AND CONTAINS CONFIDENTIAL AND TRADE SECRET INFORMATION. THIS SHEET MAY NOT BE TRANSFERRED FROM THE CUSTODY OF THE COMPETENT DIVISION OF R&D DEPARTMENT EXCEPT AS AUTHORIZED BY LC FUTURE CENTER. NEITHER THIS SHEET NOR THE INFORMATION IT CONTAINS MAY BE USED BY OR DISCLOSED TO ANY THIRD PARTY WITHOUT PRIOR WRITTEN CONSENT OF LC FUTURE CENTER.				Size Custom	Document Number ACLU1 & ACLU2
				Date:	Thursday, December 19, 2013
				Sheet	21 of 59
				Rev	1.0



+1.8VGS @ (1.8V@40mA DP_VDDR)

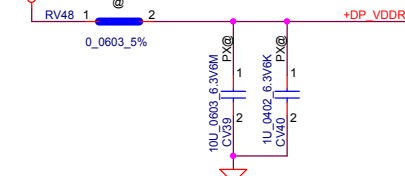

+0.95VGS @ (0.95V@32mA DP_VDDC)

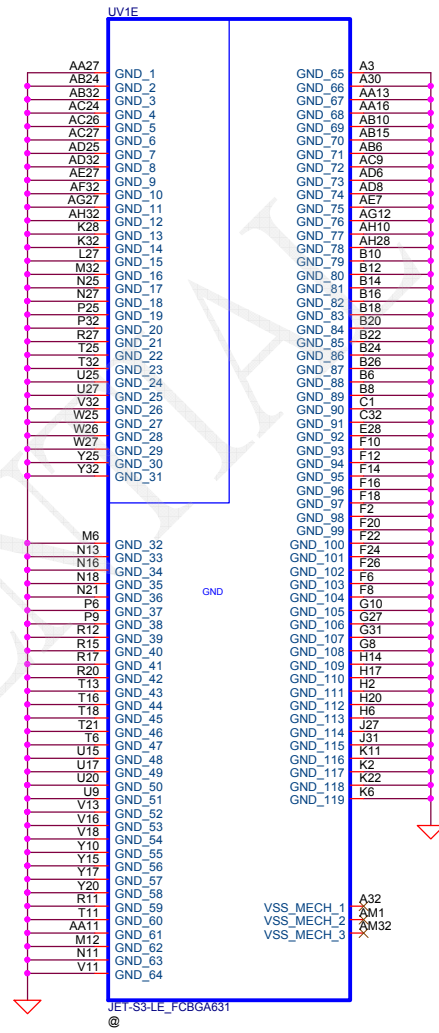
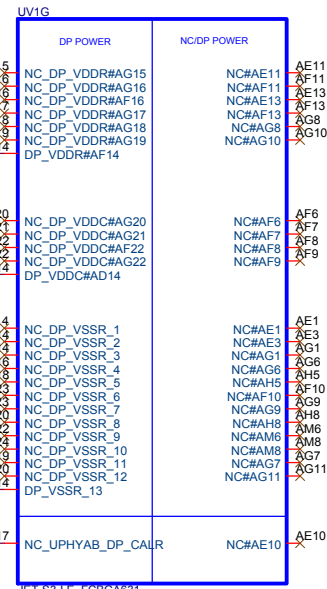
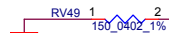
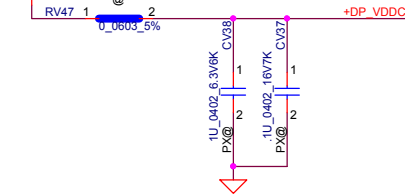

Security Classification				LC Future Center Secret Data		Title	
Issued Date	2013/08/08	Deciphered Date	2013/08/05	ATI_JET-LE_DP Power			
THIS SHEET OF ENGINEERING DRAWING IS THE PROPRIETARY PROPERTY OF LC FUTURE CENTER, AND CONTAINS CONFIDENTIAL AND TRADE SECRET INFORMATION. THIS SHEET MAY NOT BE TRANSFERRED FROM THE CUSTODY OF THE COMPETENT DIVISION OF R&D DEPARTMENT EXCEPT AS AUTHORIZED BY LC FUTURE CENTER. NEITHER THIS SHEET NOR THE INFORMATION IT CONTAINS MAY BE USED BY OR DISCLOSED TO ANY THIRD PARTY WITHOUT PRIOR WRITTEN CONSENT OF LC FUTURE CENTER.							
Size	Document Number	ACLU1 & ACLU2		Rev	1.0		
Date:	Thursday, December 19, 2013	Sheet	22	of 59			



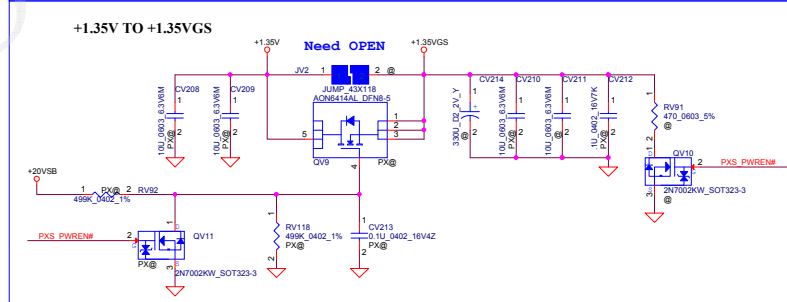
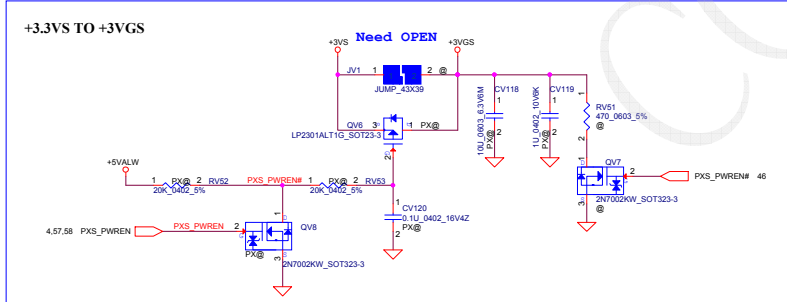
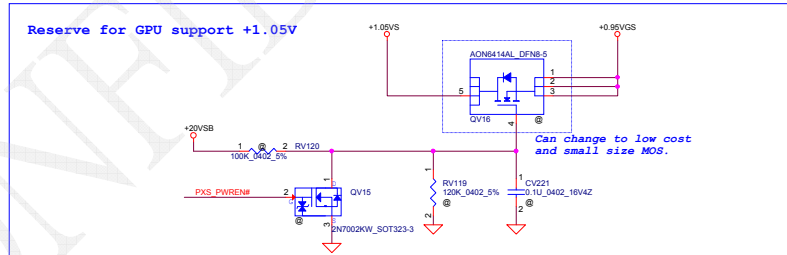
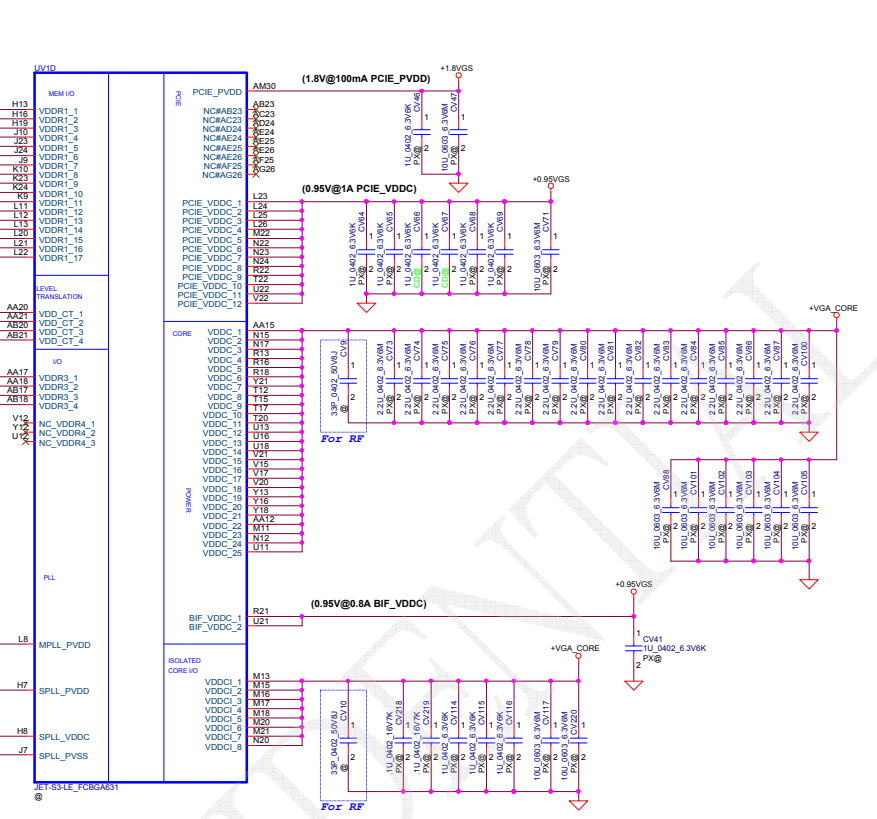
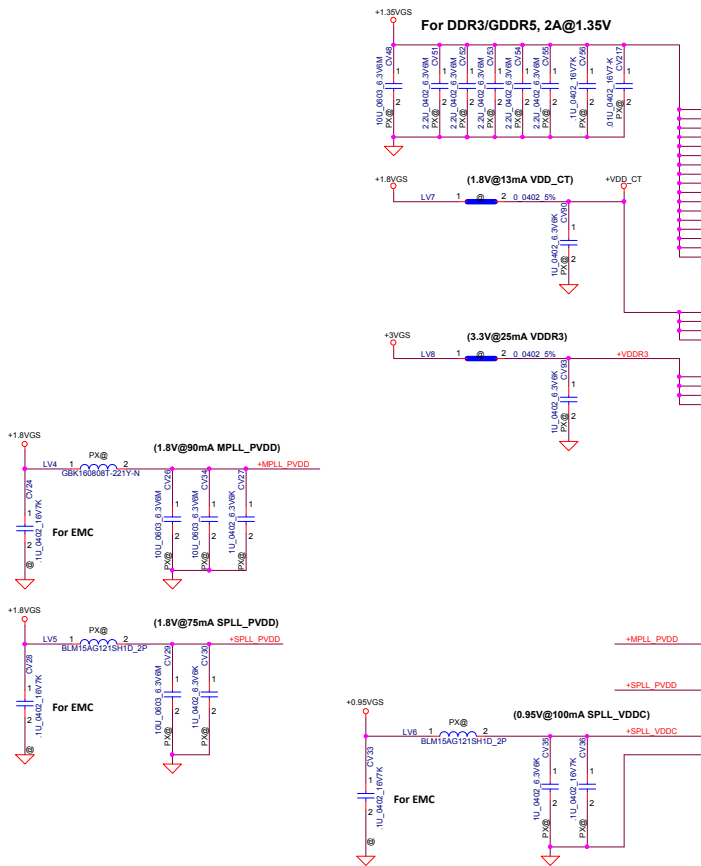

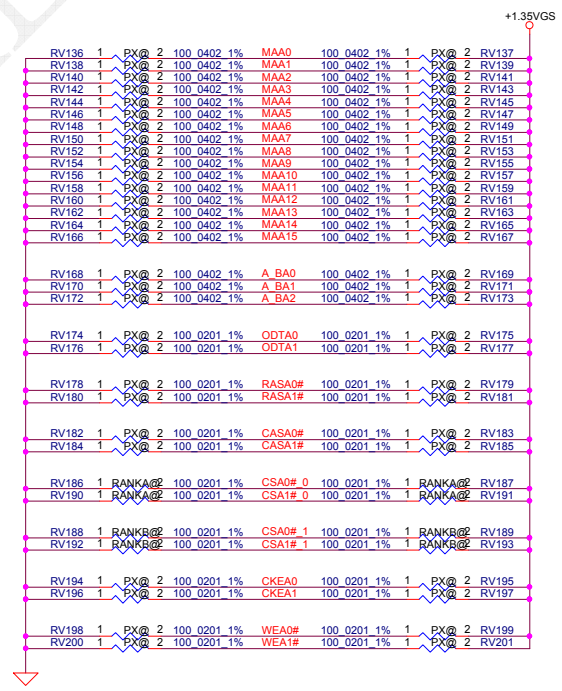
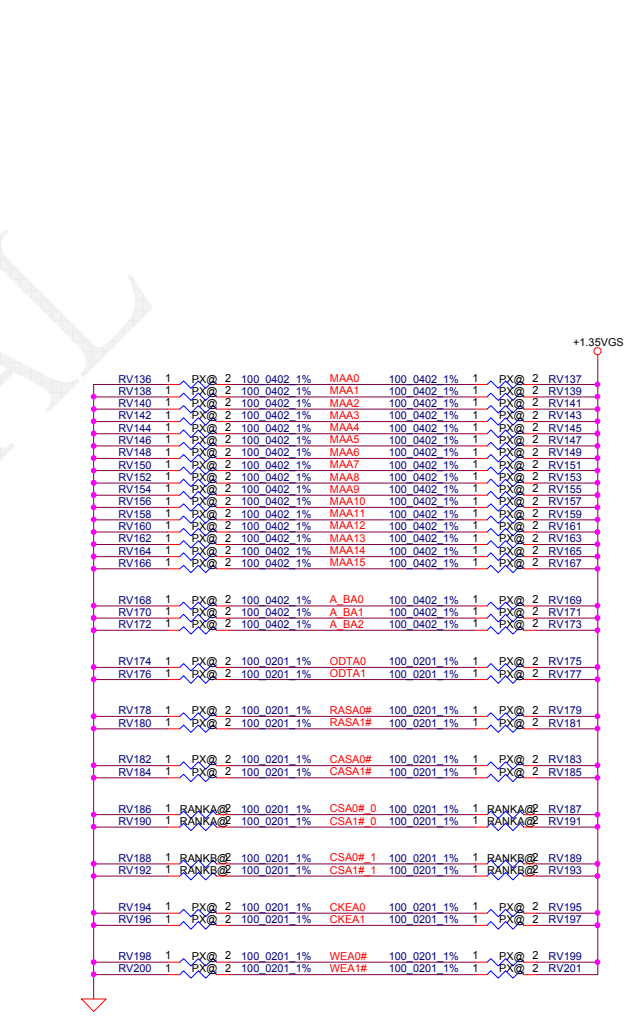
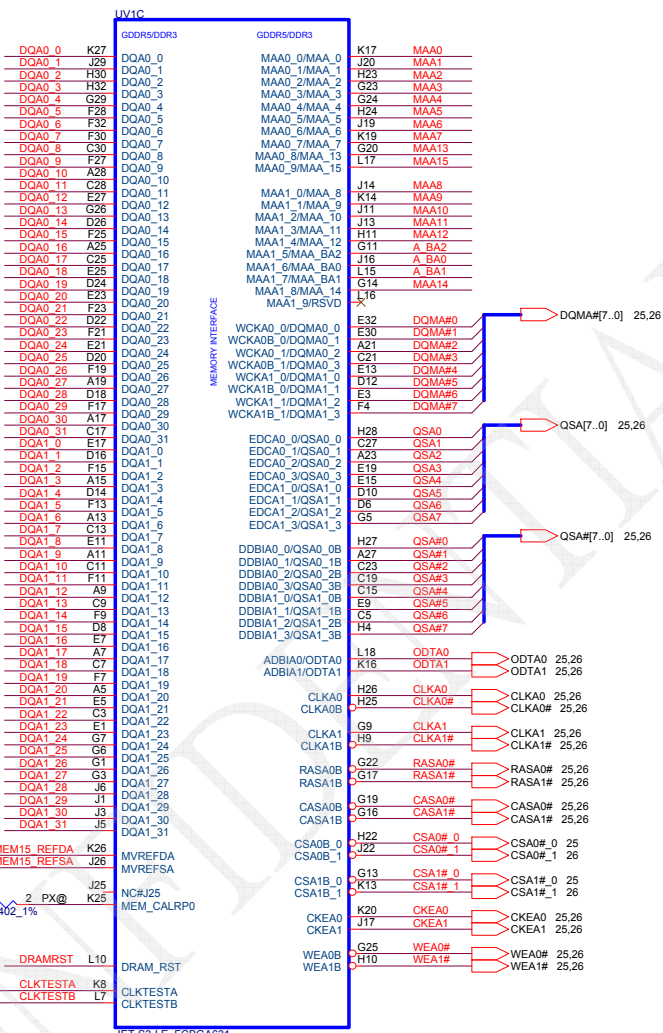
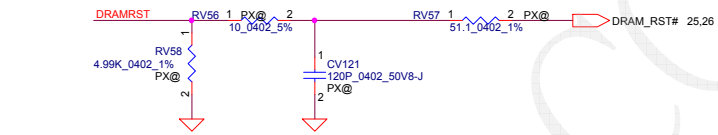
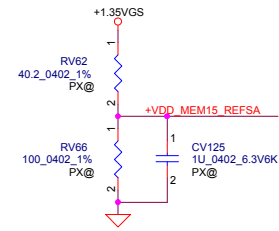
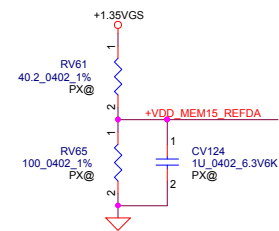
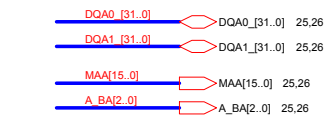

Security Classification	LC Future Center Secret Data		Title
Issued Date	2013/08/08	Deciphered Date	2013/08/05
THIS SHEET OF ENGINEERING DRAWING IS THE PROPRIETARY PROPERTY OF LC FUTURE CENTER, AND CONTAINS CONFIDENTIAL AND TRADE SECRET INFORMATION. THIS SHEET MAY NOT BE TRANSFERRED FROM THE CUSTODY OF THE COMPETENT DIVISION OF R&D DEPARTMENT EXCEPT AS AUTHORIZED BY LC FUTURE CENTER. NEITHER THIS SHEET NOR THE INFORMATION IT CONTAINS MAY BE USED BY OR DISCLOSED TO ANY THIRD PARTY WITHOUT PRIOR WRITTEN CONSENT OF LC FUTURE CENTER.			
Size	Document Number	Rev	
Custom	ACLU1 & ACLU2	1.0	
Date:	Thursday, December 18, 2013	Sheet	24 of 59

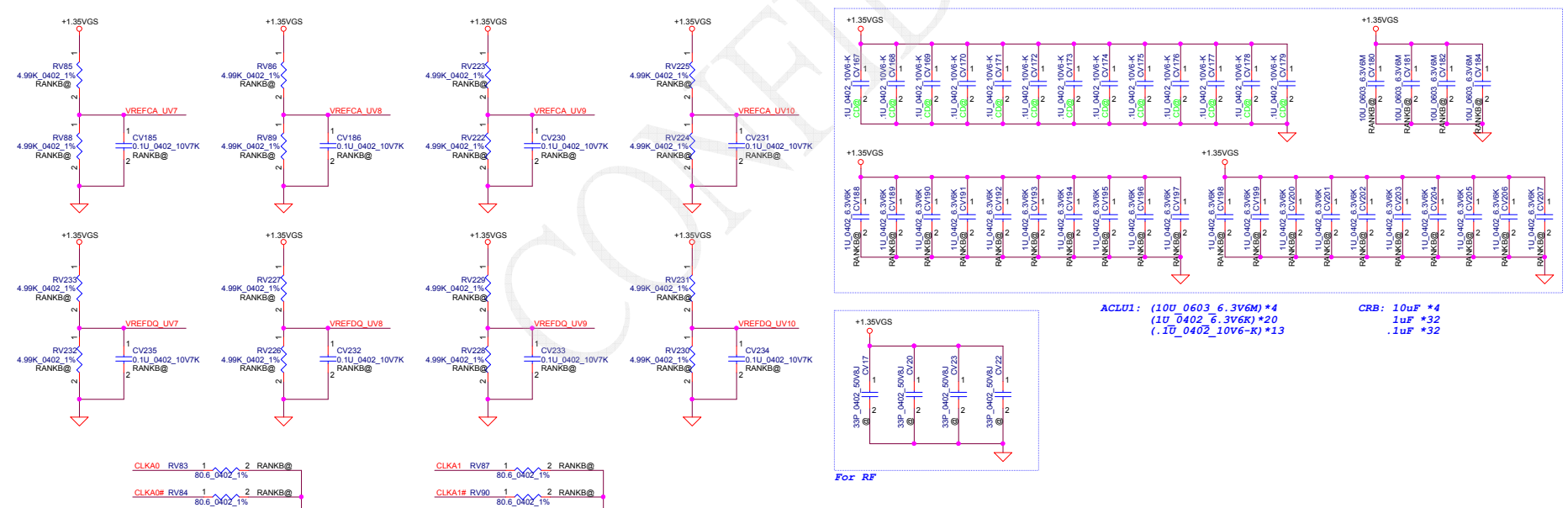
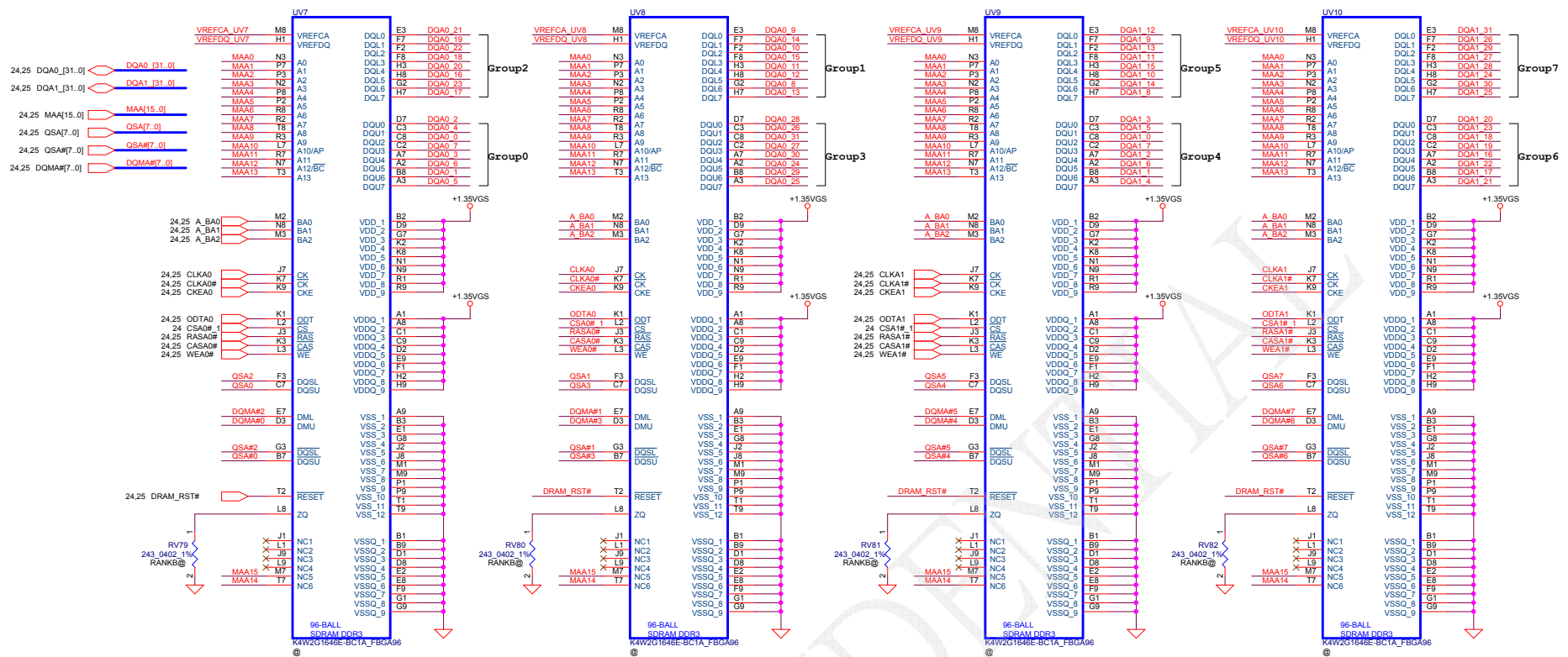

ACL1U1: (10U_0603_6_3V6M)*4
 (1U_0402_6_3V6K)*20
 (.1U_0402_10V6-K)*13

CRB: 10uF *4
 1uF *32
 .1uF *32

For RF

Security Classification		LC Future Center Secret Data		Title	
Issued Date		2013/08/08	Deciphered Date	2013/08/05	ATI_JET-LE_VRAM_B
THIS SHEET OF ENGINEERING DRAWING IS THE PROPRIETARY PROPERTY OF LC FUTURE CENTER, AND CONTAINS CONFIDENTIAL AND TRADE SECRET INFORMATION. THIS SHEET MAY NOT BE TRANSMITTED FROM THE CUSTOMER TO THE COMPONENT DIVISION OF R&D DEPARTMENT EXCEPT AS AUTHORIZED BY LC FUTURE CENTER. NEITHER THIS SHEET NOR THE INFORMATION IT CONTAINS MAY BE USED BY OR DISCLOSED TO ANY THIRD PARTY WITHOUT PRIOR WRITTEN CONSENT OF LC FUTURE CENTER.					
Size	Document Number	Rev			1.0
Date:	Thursday, December 16, 2013	Sheet	26	of	59

CONFIDENTIAL

Security Classification	LC Future Center Secret Data		Title	
Issued Date	2013/08/08	Deciphered Date	2013/08/05	
THIS SHEET OF ENGINEERING DRAWING IS THE PROPRIETARY PROPERTY OF LC FUTURE CENTER, AND CONTAINS CONFIDENTIAL AND TRADE SECRET INFORMATION. THIS SHEET MAY NOT BE TRANSFERRED FROM THE CUSTODY OF THE COMPETENT DIVISION OF R&D DEPARTMENT EXCEPT AS AUTHORIZED BY LC FUTURE CENTER. NEITHER THIS SHEET NOR THE INFORMATION IT CONTAINS MAY BE USED BY OR DISCLOSED TO ANY THIRD PARTY WITHOUT PRIOR WRITTEN CONSENT OF LC FUTURE CENTER.				
Size	Document Number	Rev		
Custom	ACL01 & ACL02	1.0		
Date:	Thursday, December 19, 2013	Sheet	27	of 59

CONFIDENTIAL

Security Classification	LC Future Center Secret Data		Title			
Issued Date	2013/08/08	Deciphered Date	2013/08/05		Blank	
THIS SHEET OF ENGINEERING DRAWING IS THE PROPRIETARY PROPERTY OF LC FUTURE CENTER, AND CONTAINS CONFIDENTIAL AND TRADE SECRET INFORMATION. THIS SHEET MAY NOT BE TRANSFERRED FROM THE CUSTODY OF THE COMPETENT DIVISION OF R&D DEPARTMENT EXCEPT AS AUTHORIZED BY LC FUTURE CENTER. NEITHER THIS SHEET NOR THE INFORMATION IT CONTAINS MAY BE USED BY OR DISCLOSED TO ANY THIRD PARTY WITHOUT PRIOR WRITTEN CONSENT OF LC FUTURE CENTER.				Size Custom	Document Number ACL01 & ACL02	Rev 1.0
				Date:	Thursday, December 19, 2013	Sheet 28 of 59

CONFIDENTIAL

Security Classification	LC Future Center Secret Data			Title	 Blank	
Issued Date	2013/08/08	Deciphered Date	2013/08/05	Size		Document Number
THIS SHEET OF ENGINEERING DRAWING IS THE PROPRIETARY PROPERTY OF LC FUTURE CENTER, AND CONTAINS CONFIDENTIAL AND TRADE SECRET INFORMATION. THIS SHEET MAY NOT BE TRANSFERRED FROM THE CUSTODY OF THE COMPETENT DIVISION OF R&D DEPARTMENT EXCEPT AS AUTHORIZED BY LC FUTURE CENTER. NEITHER THIS SHEET NOR THE INFORMATION IT CONTAINS MAY BE USED BY OR DISCLOSED TO ANY THIRD PARTY WITHOUT PRIOR WRITTEN CONSENT OF LC FUTURE CENTER.				Custom	ACL01 & ACL02	1.0
				Date:	Thursday, December 19, 2013	Sheet 29 of 59

CONFIDENTIAL

Security Classification	LC Future Center Secret Data		Title			
Issued Date	2013/08/08	Deciphered Date	2013/08/05		Blank	
THIS SHEET OF ENGINEERING DRAWING IS THE PROPRIETARY PROPERTY OF LC FUTURE CENTER, AND CONTAINS CONFIDENTIAL AND TRADE SECRET INFORMATION. THIS SHEET MAY NOT BE TRANSFERRED FROM THE CUSTODY OF THE COMPETENT DIVISION OF R&D DEPARTMENT EXCEPT AS AUTHORIZED BY LC FUTURE CENTER. NEITHER THIS SHEET NOR THE INFORMATION IT CONTAINS MAY BE USED BY OR DISCLOSED TO ANY THIRD PARTY WITHOUT PRIOR WRITTEN CONSENT OF LC FUTURE CENTER.				Size Custom	Document Number ACL01 & ACL02	Rev 1.0
				Date:	Thursday, December 19, 2013	Sheet 30 of 59

CONFIDENTIAL

Security Classification	LC Future Center Secret Data		Title	
Issued Date	2013/08/08	Deciphered Date	2013/08/05	
THIS SHEET OF ENGINEERING DRAWING IS THE PROPRIETARY PROPERTY OF LC FUTURE CENTER, AND CONTAINS CONFIDENTIAL AND TRADE SECRET INFORMATION. THIS SHEET MAY NOT BE TRANSFERRED FROM THE CUSTODY OF THE COMPETENT DIVISION OF R&D DEPARTMENT EXCEPT AS AUTHORIZED BY LC FUTURE CENTER. NEITHER THIS SHEET NOR THE INFORMATION IT CONTAINS MAY BE USED BY OR DISCLOSED TO ANY THIRD PARTY WITHOUT PRIOR WRITTEN CONSENT OF LC FUTURE CENTER.				
Size	Document Number	Rev		
Custom	ACL01 & ACL02	1.0		
Date:	Thursday, December 19, 2013	Sheet	31	of 59

CONFIDENTIAL

Security Classification	LC Future Center Secret Data		Title			
Issued Date	2013/08/08	Deciphered Date	2013/08/05		Blank	
THIS SHEET OF ENGINEERING DRAWING IS THE PROPRIETARY PROPERTY OF LC FUTURE CENTER, AND CONTAINS CONFIDENTIAL AND TRADE SECRET INFORMATION. THIS SHEET MAY NOT BE TRANSFERRED FROM THE CUSTODY OF THE COMPETENT DIVISION OF R&D DEPARTMENT EXCEPT AS AUTHORIZED BY LC FUTURE CENTER. NEITHER THIS SHEET NOR THE INFORMATION IT CONTAINS MAY BE USED BY OR DISCLOSED TO ANY THIRD PARTY WITHOUT PRIOR WRITTEN CONSENT OF LC FUTURE CENTER.				Size Custom	Document Number ACLU1 & ACLU2	Rev 1.0
				Date:	Thursday, December 19, 2013	Sheet 32 of 59

LCD POWER CIRCUIT

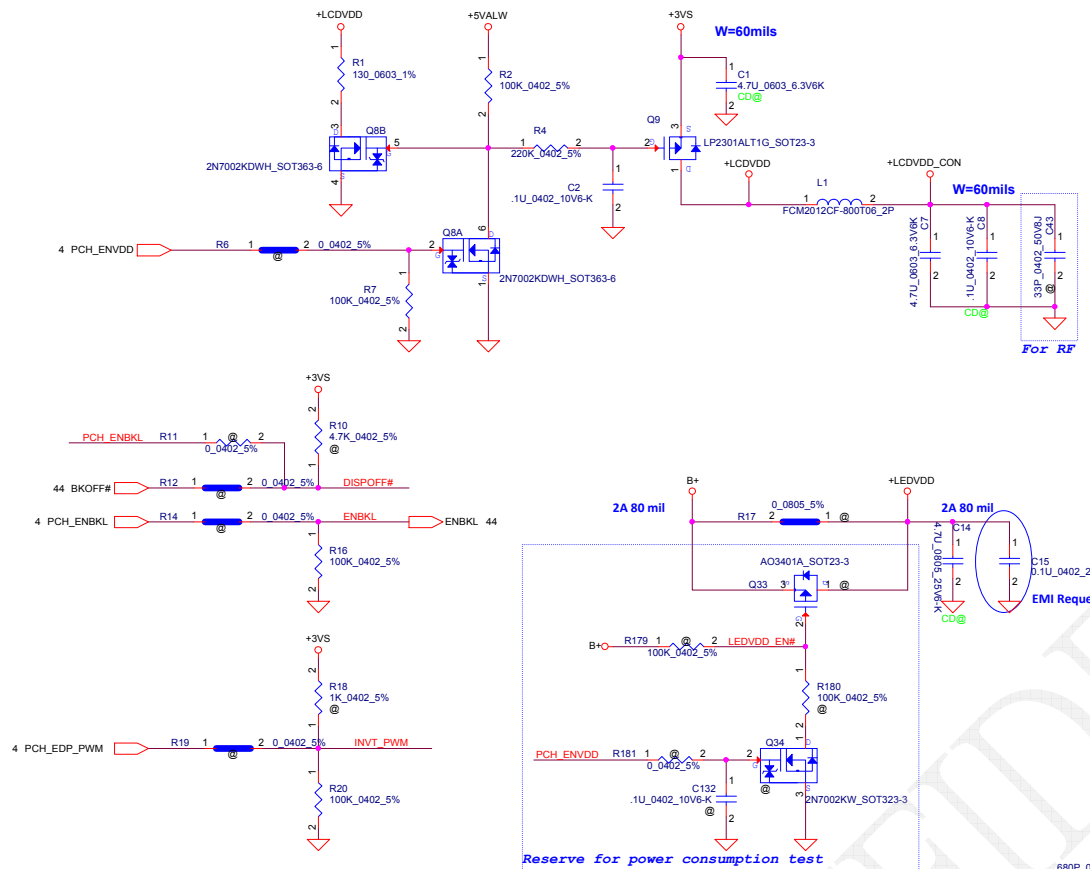

CMOS Camera

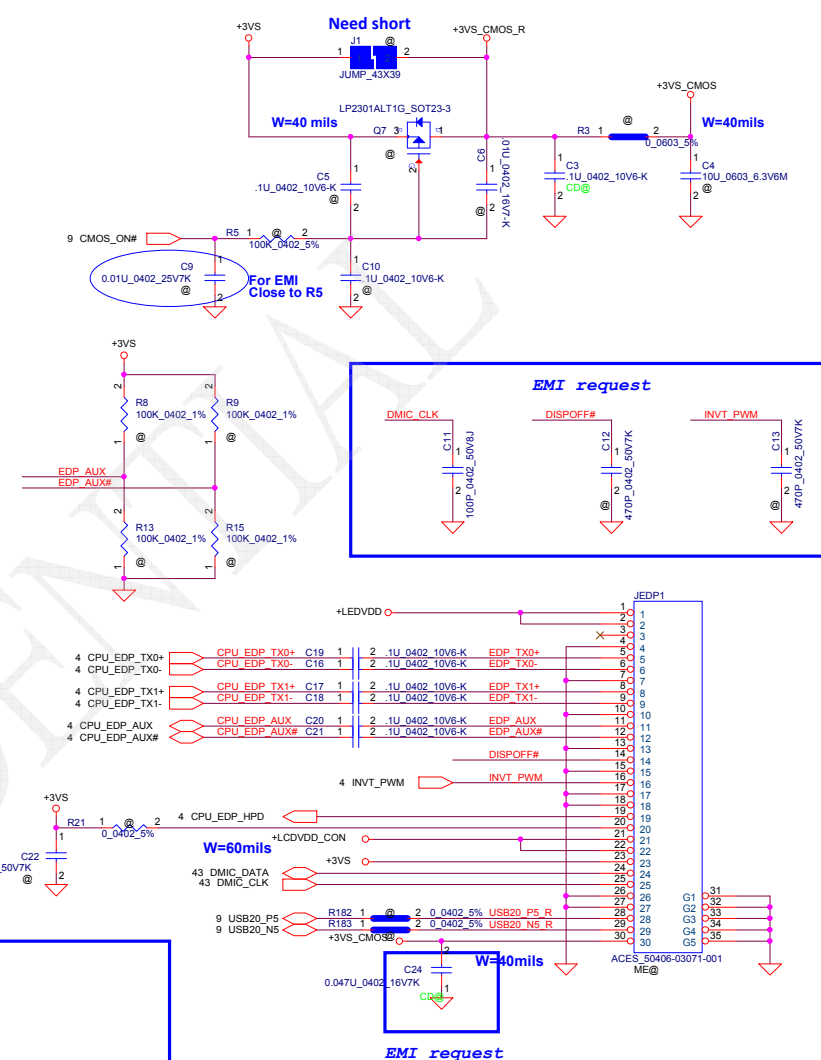

Touch Screen

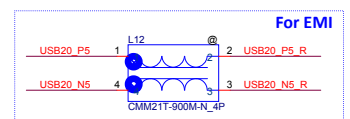
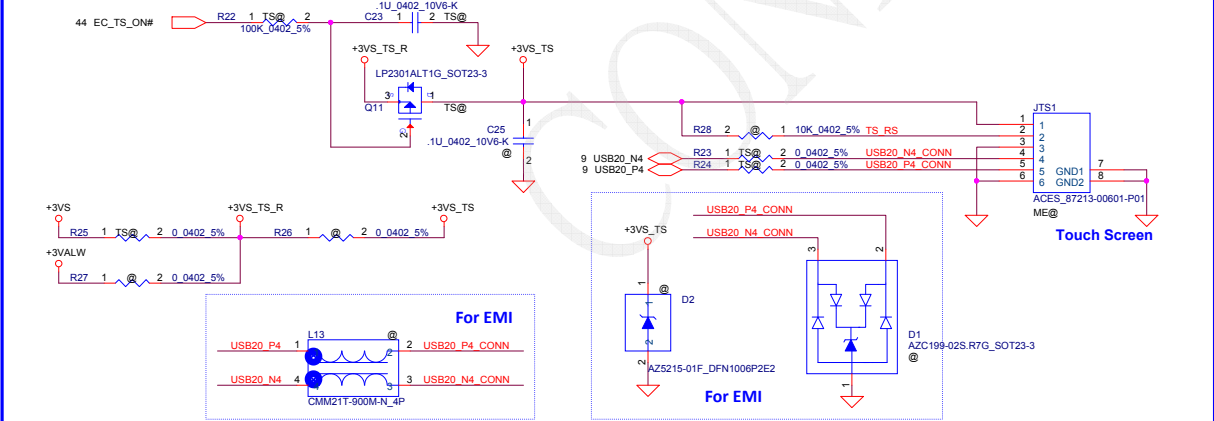

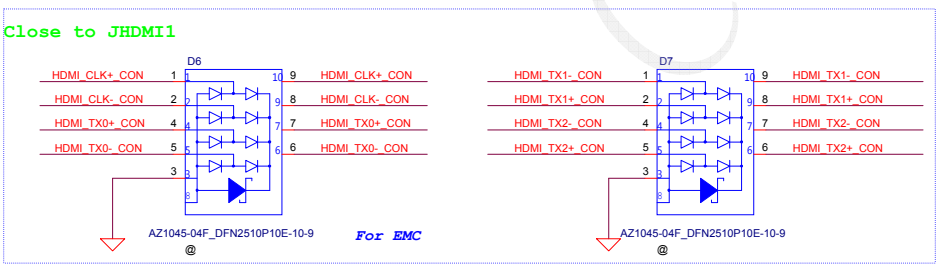
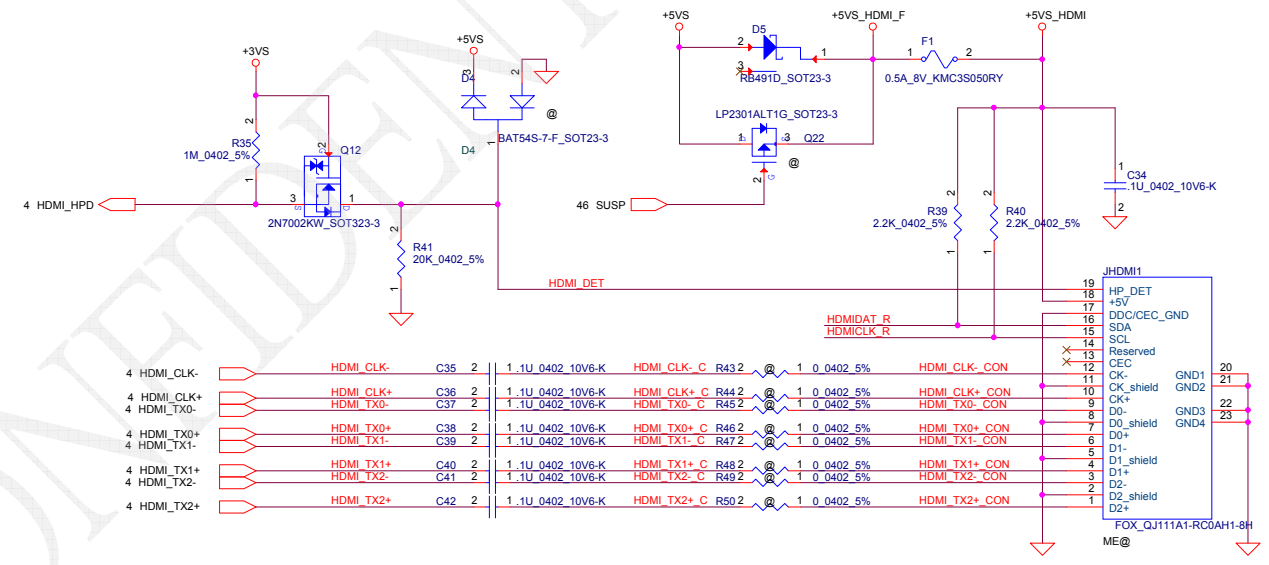
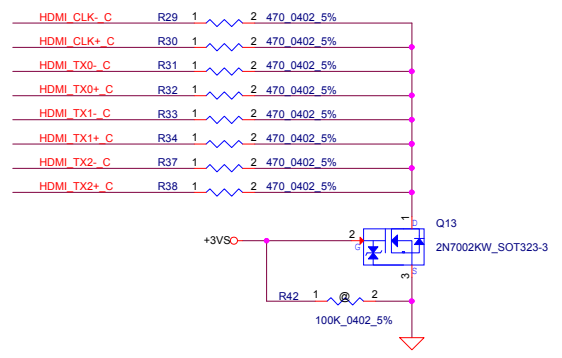
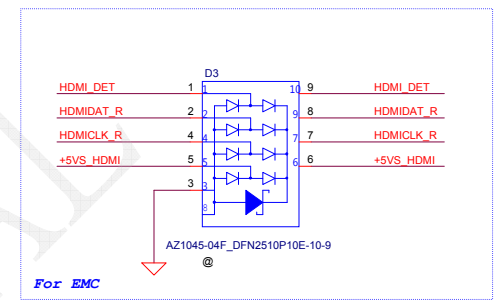
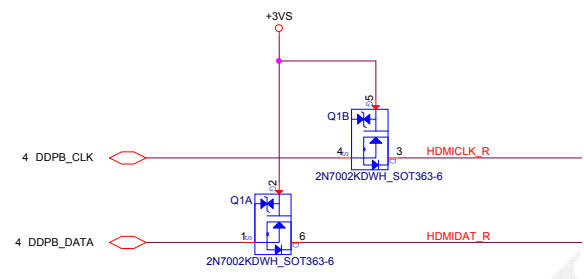
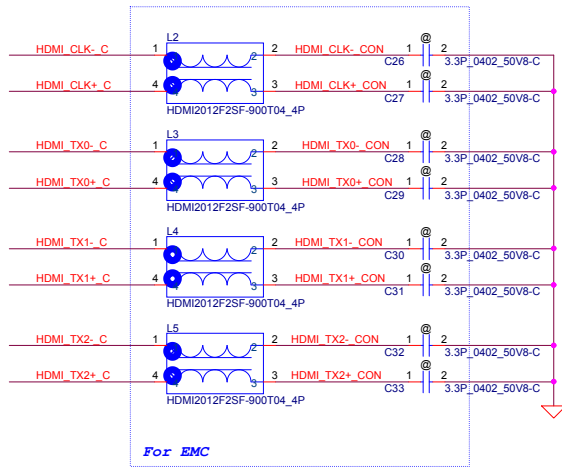

Security Classification	LC Future Center Secret Data			Title	
Issued Date	2013/08/08	Deciphered Date	2013/08/05	HDMI_CONN	
<small>THIS SHEET OF ENGINEERING DRAWING IS THE PROPRIETARY PROPERTY OF LC FUTURE CENTER, AND CONTAINS CONFIDENTIAL AND TRADE SECRET INFORMATION. THIS SHEET MAY NOT BE TRANSFERRED FROM THE CUSTODY OF THE COMPETENT DIVISION OF DEPARTMENT EXCEPT AS AUTHORIZED BY LC FUTURE CENTER NEITHER THIS SHEET NOR THE INFORMATION IT CONTAINS MAY BE USED BY OR DISCLOSED TO ANY THIRD PARTY WITHOUT PRIOR WRITTEN CONSENT OF LC FUTURE CENTER.</small>					
Revision	1	Document Number	Custom	ACL1 & ACL2	
Date:	Tuesday, December 24, 2013			Sheet	34 of 59

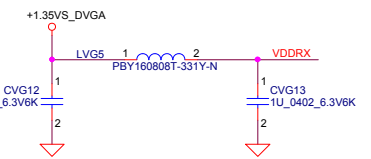
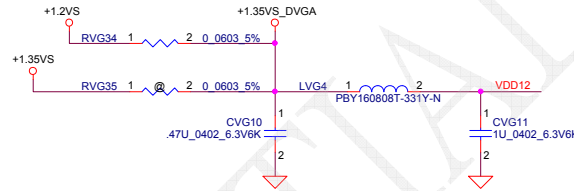
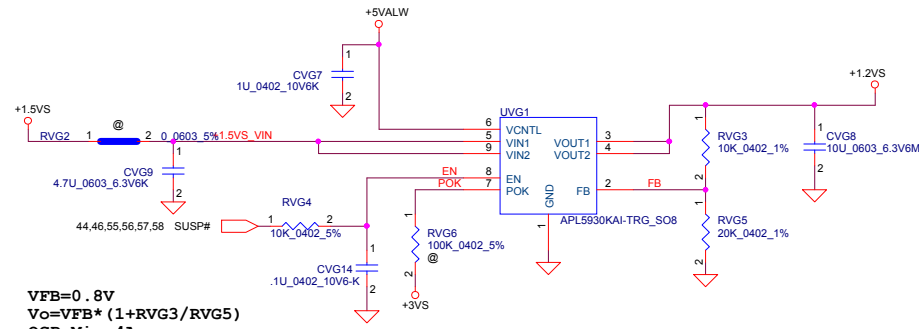
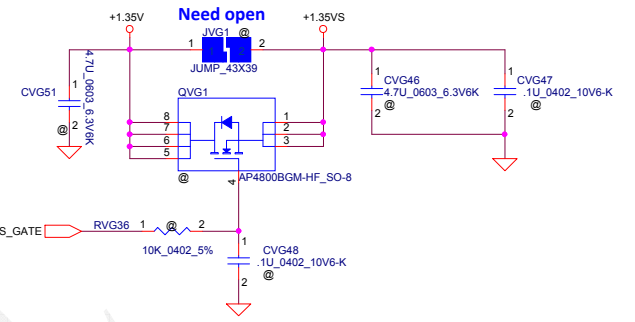
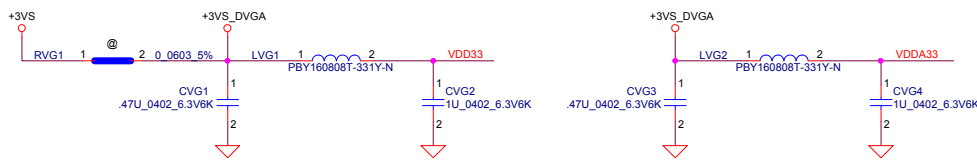

VFB=0.8V
 $V_o = VFB * (1 + RVG3/RVG5)$
 OCP: Min 4A

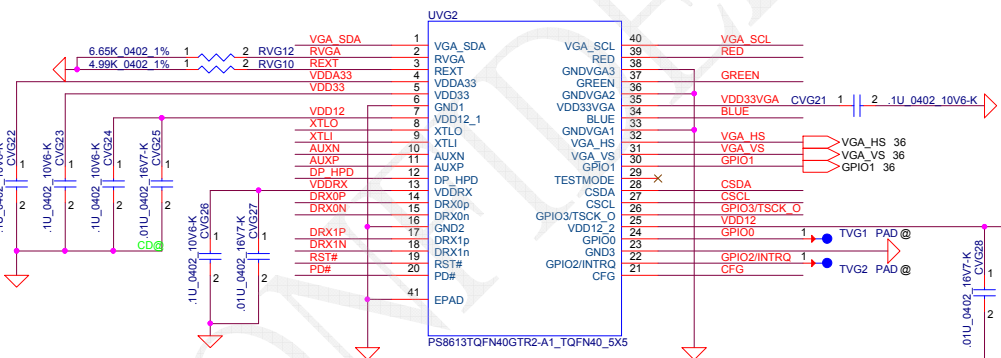
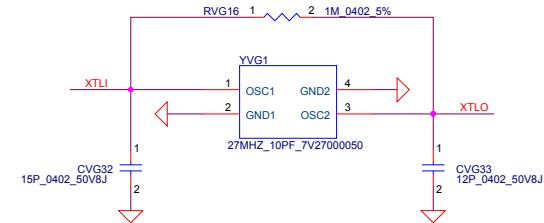
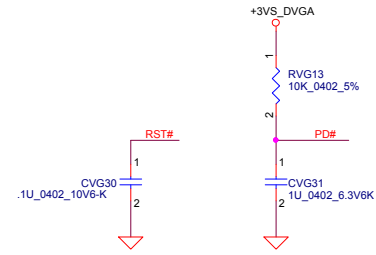
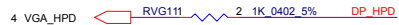
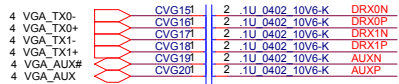

Update DP Convert Version from A0 to A1

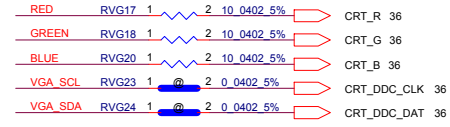

Initial code loading selection, internal pull down ~80kΩ:
 L: Loading initial code from internal MTP ROM
 H: No initial code loading, external I2C control is expected

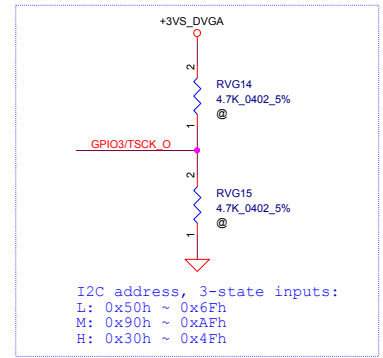

Security Classification				LC Future Center Secret Data		Title	
Issued Date	2013/08/08	Deciphered Date	2013/08/05	DP to CRT Converter(PS8613)			
THIS SHEET OF ENGINEERING DRAWING IS THE PROPRIETARY PROPERTY OF LC FUTURE CENTER, AND CONTAINS CONFIDENTIAL AND TRADE SECRET INFORMATION. THIS SHEET MAY NOT BE TRANSFERRED FROM THE CUSTODY OF THE COMPETENT DIVISION OF DEPARTMENT EXCEPT AS AUTHORIZED BY LC FUTURE CENTER. NEITHER THIS SHEET NOR THE INFORMATION IT CONTAINS MAY BE USED BY OR DISCLOSED TO ANY THIRD PARTY WITHOUT PRIOR WRITTEN CONSENT OF LC FUTURE CENTER.							
Size	Document Number	Custom	ACLUI & ACLU2		Rev	1.0	
Date:	Thursday, December 19, 2013			Sheet	35 of 59		

CRT Connector

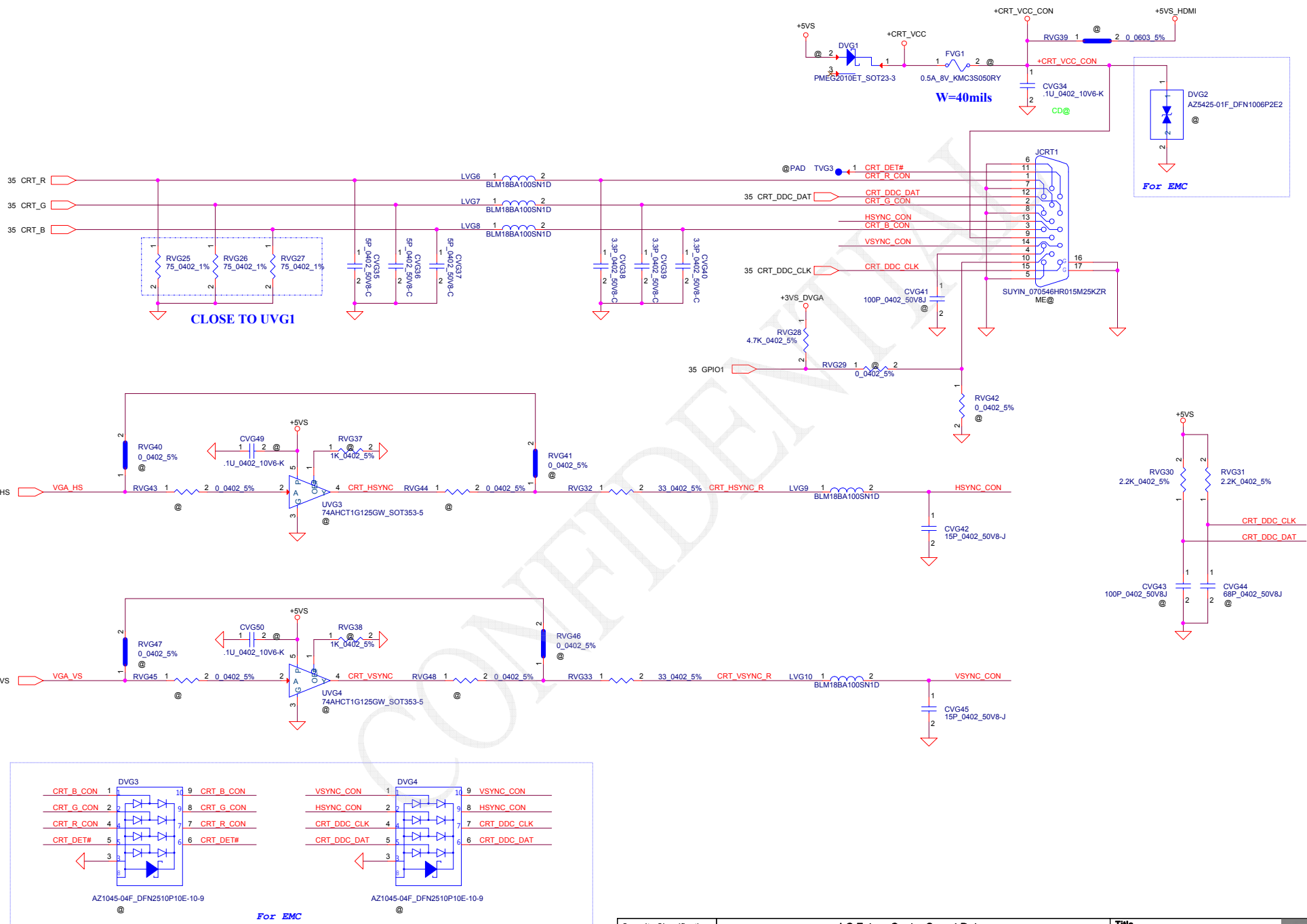

Security Classification	LC Future Center Secret Data	
Issued Date	2013/08/08	Deciphered Date
		2013/08/05
THIS SHEET OF ENGINEERING DRAWING IS THE PROPRIETARY PROPERTY OF LC FUTURE CENTER, AND CONTAINS CONFIDENTIAL AND TRADE SECRET INFORMATION. THIS SHEET MAY NOT BE TRANSFERRED FROM THE CUSTODY OF THE COMPETENT DIVISION OF DEPARTMENT EXCEPT AS AUTHORIZED BY LC FUTURE CENTER. NEITHER THIS SHEET NOR THE INFORMATION IT CONTAINS MAY BE USED BY OR DISCLOSED TO ANY THIRD PARTY WITHOUT PRIOR WRITTEN CONSENT OF LC FUTURE CENTER.		

Title	Size	Document Number	Rev
CRT	Custom	ACLU1 & ACLU2	1.0
Date:	Thursday, December 19, 2013 Sheet 36 of 59		



+3VALW TO +3VALW_LAN

**+3VALW_LAN rising time (10%~90%):
0.5ms < spec < 100ms**

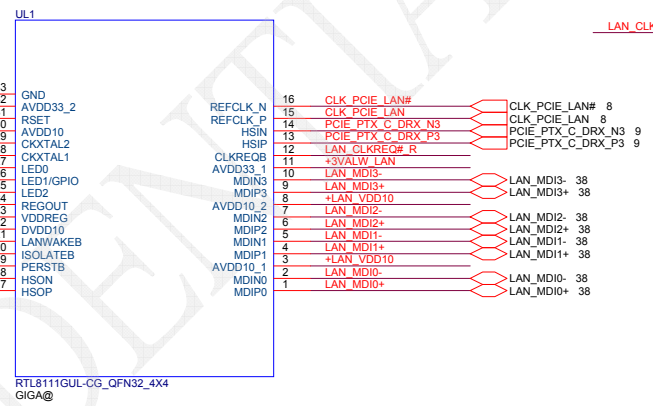
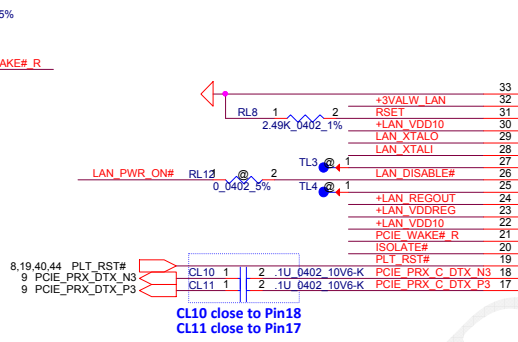
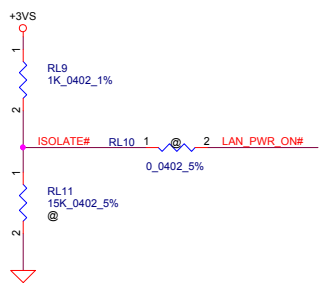
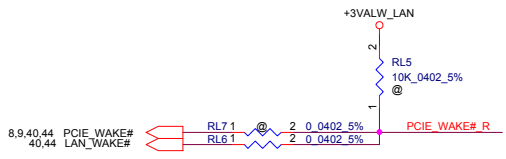
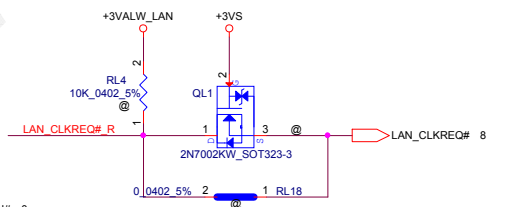
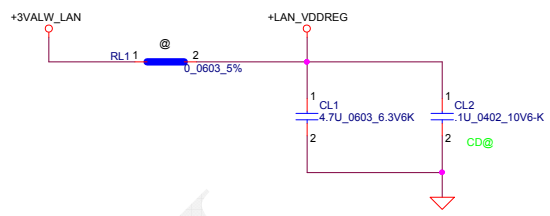
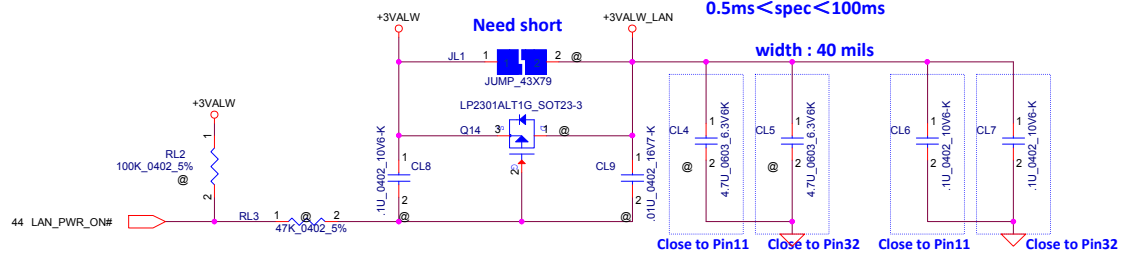

For RTL8111GUL/RTL8106EUL (SWR mode)

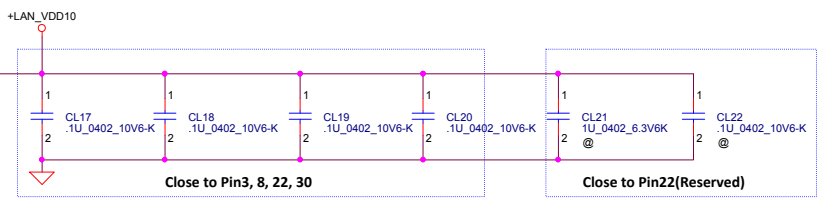
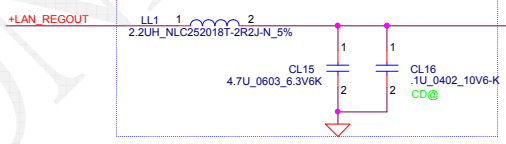
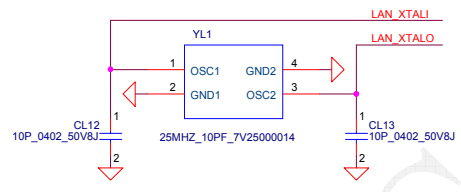

Layout Note: LL1 must be within 200mil to Pin24.
CL15, CL16 must be within 200mil to LL1
+LAN_REGOUT: Width =60mil

Security Classification		LC Future Center Secret Data		Title	
Issued Date	2013/08/08	Deciphered Date	2013/08/05	LAN_RTL8111GUL/RTL8106EUL	
THIS SHEET OF ENGINEERING DRAWING IS THE PROPRIETARY PROPERTY OF LC FUTURE CENTER AND CONTAINS CONFIDENTIAL AND TRADE SECRET INFORMATION. THIS SHEET MAY NOT BE TRANSFERRED FROM THE CUSTODY OF THE COMPETENT DIVISION OF R&D DEPARTMENT EXCEPT AS AUTHORIZED BY LC FUTURE CENTER NEITHER THIS SHEET NOR THE INFORMATION IT CONTAINS MAY BE USED BY OR DISCLOSED TO ANY THIRD PARTY WITHOUT PRIOR WRITTEN CONSENT OF LC FUTURE CENTER.					
Size Custom	Document Number	ACL01 & ACLU2		Rev	1.0
Date:	Thursday, December 19, 2013	Sheet	37	of	59

DL1/DL2
1'S PN:SC300003M00

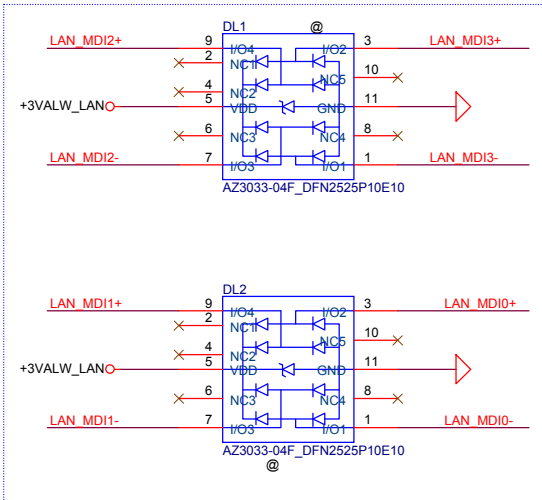

Place Close to TL1

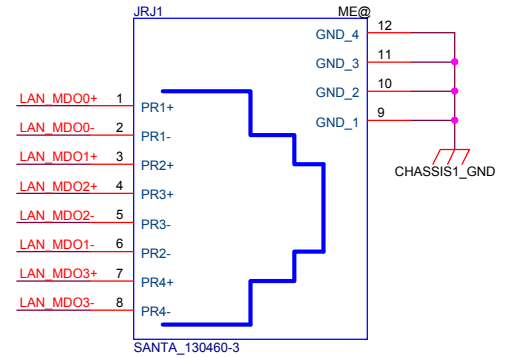
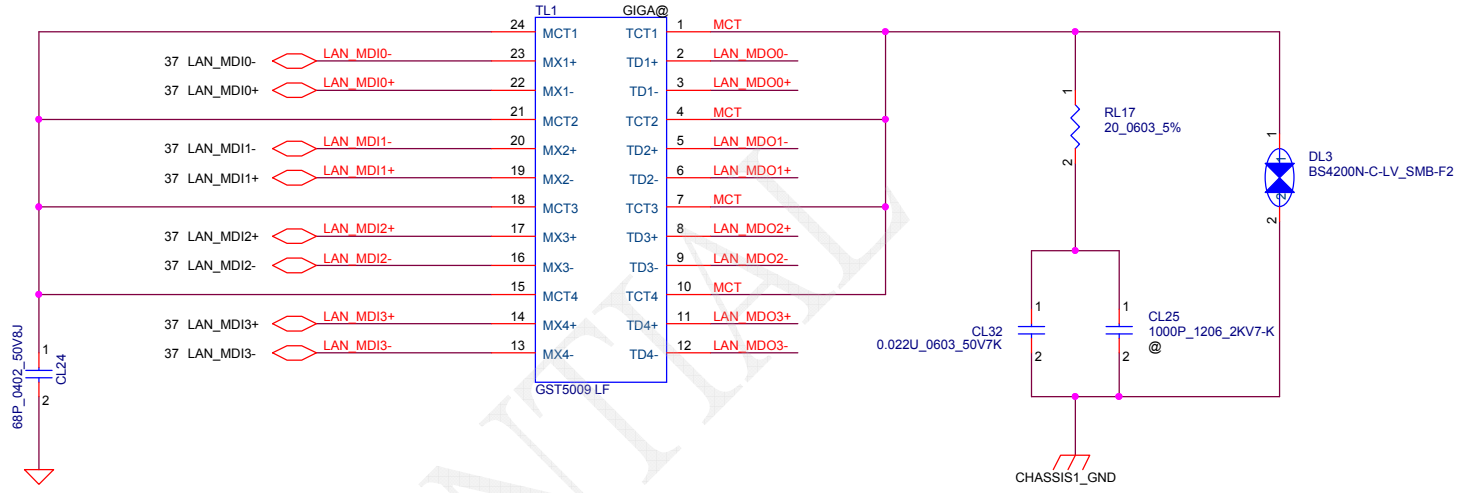
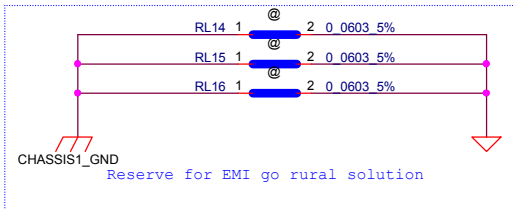

Security Classification	LC Future Center Secret Data			Title	
Issued Date	2013/08/08	Deciphered Date	2013/08/05	LAN_Transformer	
THIS SHEET OF ENGINEERING DRAWING IS THE PROPRIETARY PROPERTY OF LC FUTURE CENTER. AND CONTAINS CONFIDENTIAL AND TRADE SECRET INFORMATION. THIS SHEET MAY NOT BE TRANSFERRED FROM THE CUSTODY OF THE COMPETENT DIVISION OF R&D DEPARTMENT EXCEPT AS AUTHORIZED BY LC FUTURE CENTER NEITHER THIS SHEET NOR THE INFORMATION IT CONTAINS MAY BE USED BY OR DISCLOSED TO ANY THIRD PARTY WITHOUT PRIOR WRITTEN CONSENT OF LC FUTURE CENTER.				Document Number	Rev
				ACLUI & ACLU2	1.0
				Date: Thursday, December 19, 2013	Sheet 38 of 59

Close to U1

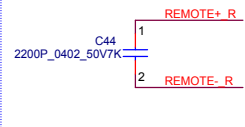

SMSC thermal sensor placed near DIMM

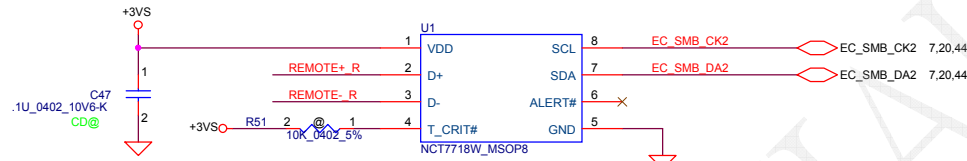

Address 1001_100xb

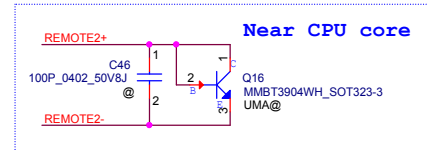
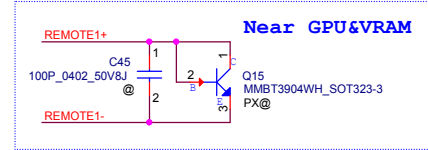

REMOTE+/- R, REMOTE1+/-, REMOTE2+/-:
Trace width/space:10/10 mil
Trace length:<8"

FAN Conn

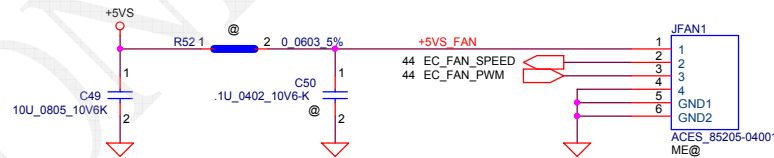

Security Classification	LC Future Center Secret Data	
Issued Date	2013/08/08	Deciphered Date
THIS SHEET OF ENGINEERING DRAWING IS THE PROPRIETARY PROPERTY OF LC FUTURE CENTER, AND CONTAINS CONFIDENTIAL AND TRADE SECRET INFORMATION. THIS SHEET MAY NOT BE TRANSFERRED FROM THE CUSTODY OF THE COMPETENT DIVISION OF R&D DEPARTMENT EXCEPT AS AUTHORIZED BY LC FUTURE CENTER NEITHER THIS SHEET NOR THE INFORMATION IT CONTAINS MAY BE USED BY OR DISCLOSED TO ANY THIRD PARTY WITHOUT PRIOR WRITTEN CONSENT OF LC FUTURE CENTER.		

Title		
Thermal sensor/FAN CONN		
Size	Document Number	ACLU1 & ACLU2
Custom		
Date:	Thursday, December 19, 2013	Sheet 39 of 59

Rev 1.0

Mini-Express Card(WLAN/WiMAX)

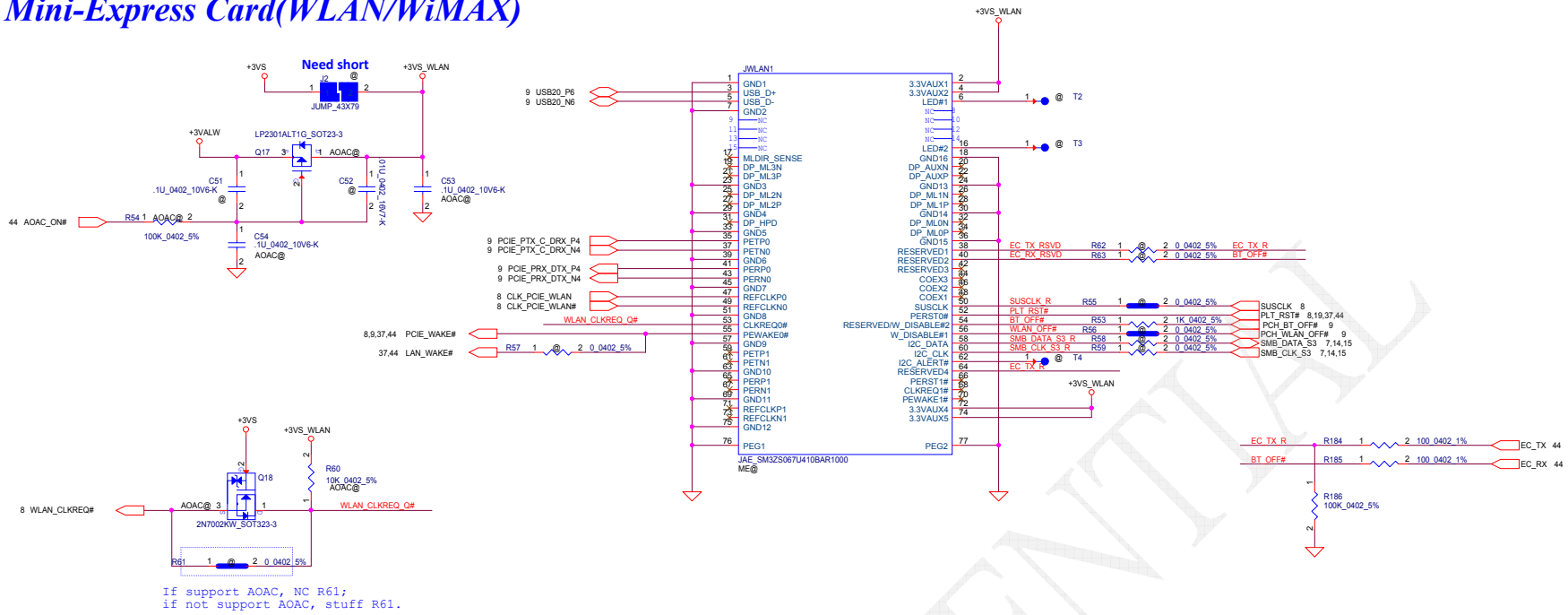

LEFT SIDE USB3.0 PORT X2

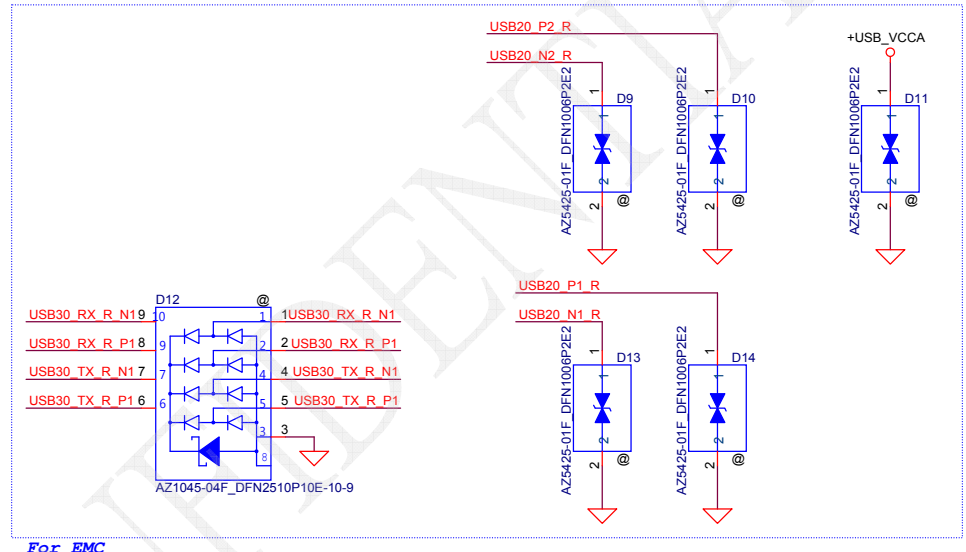
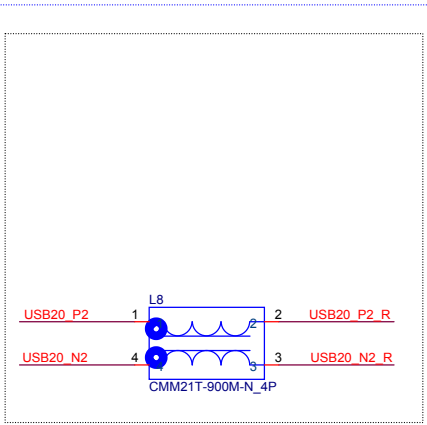
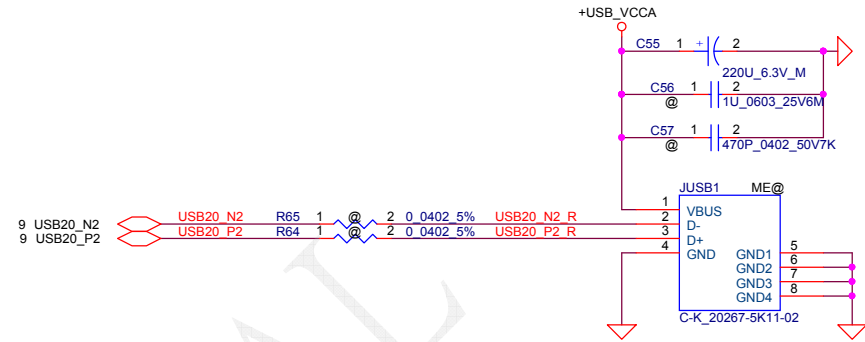
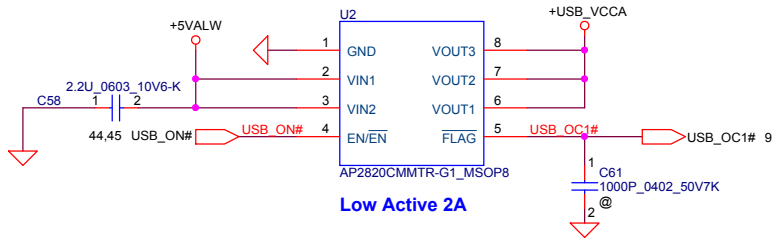

For EMC

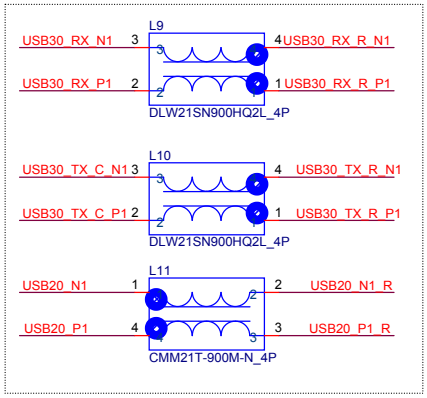

For EMC

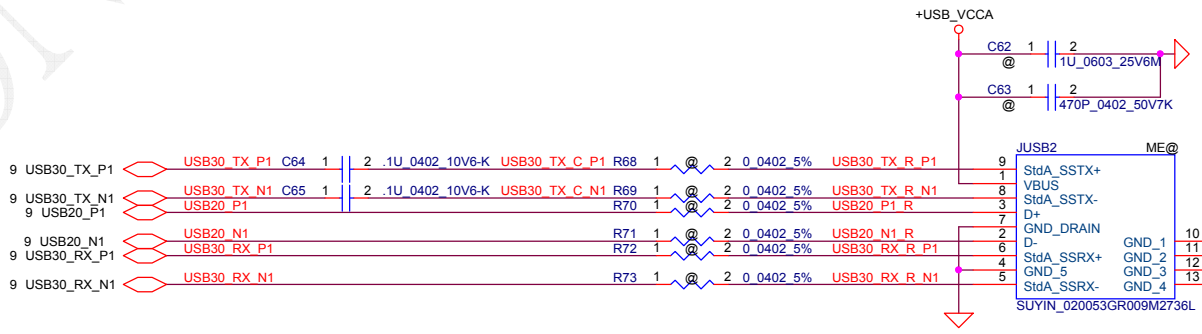

Security Classification		LC Future Center Secret Data	
Issued Date	2013/08/08	Deciphered Date	2013/08/05
THIS SHEET OF ENGINEERING DRAWING IS THE PROPRIETARY PROPERTY OF LC FUTURE CENTER, AND CONTAINS CONFIDENTIAL AND TRADE SECRET INFORMATION. THIS SHEET MAY NOT BE TRANSFERRED FROM THE CUSTODY OF THE COMPETENT DIVISION OF THE DEPARTMENT EXCEPT AS AUTHORIZED BY LC FUTURE CENTER. NEITHER THIS SHEET NOR THE INFORMATION IT CONTAINS MAY BE USED BY OR DISCLOSED TO ANY THIRD PARTY WITHOUT PRIOR WRITTEN CONSENT OF LC FUTURE CENTER.			

Title		
USB2.0/USB3.0 PORT (LEFT)		
Size	Document Number	ACLU1 & ACLU2
Date	Thursday, December 19, 2013	
Sheet	41	Rev 1.0
of	59	

SATA HDD Conn.

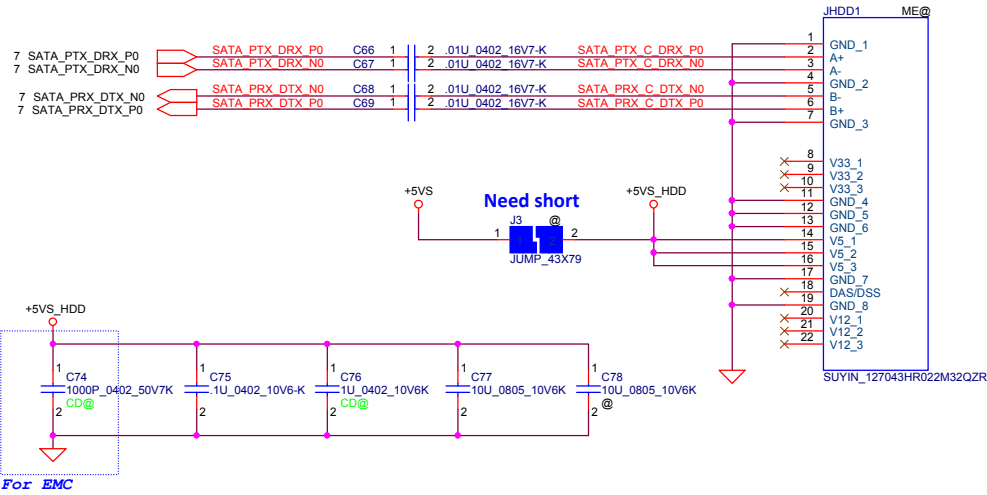

FOR 14" SATA ODD Conn.

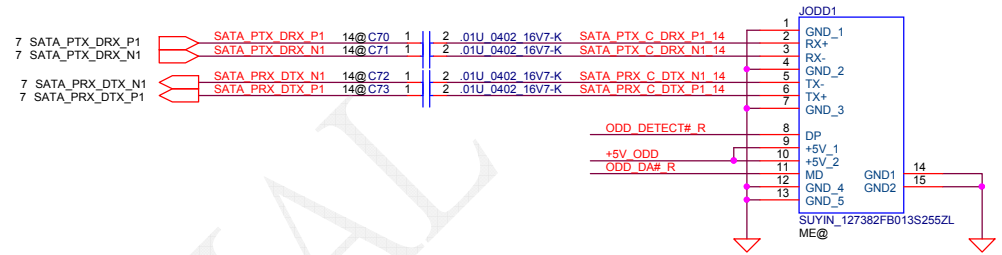

FOR 15" SATA ODD FFC Conn

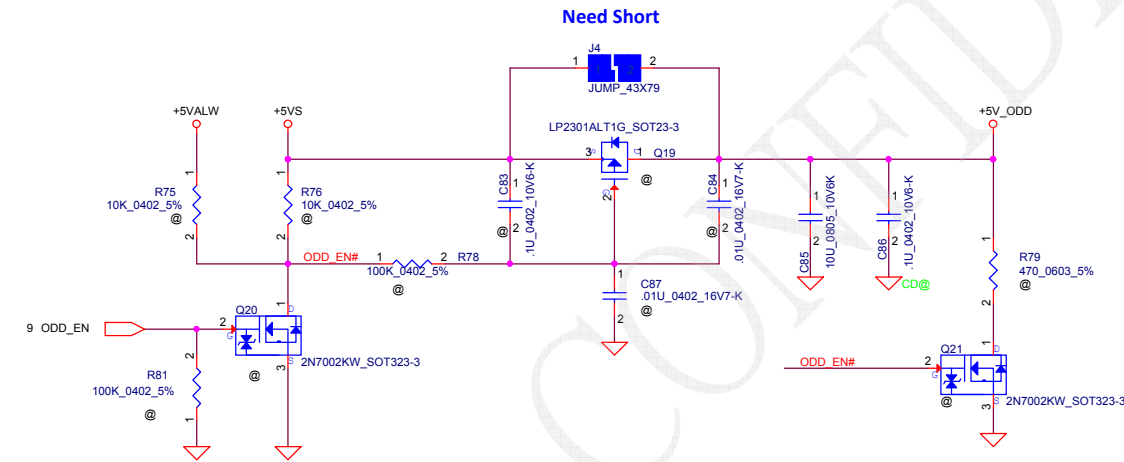
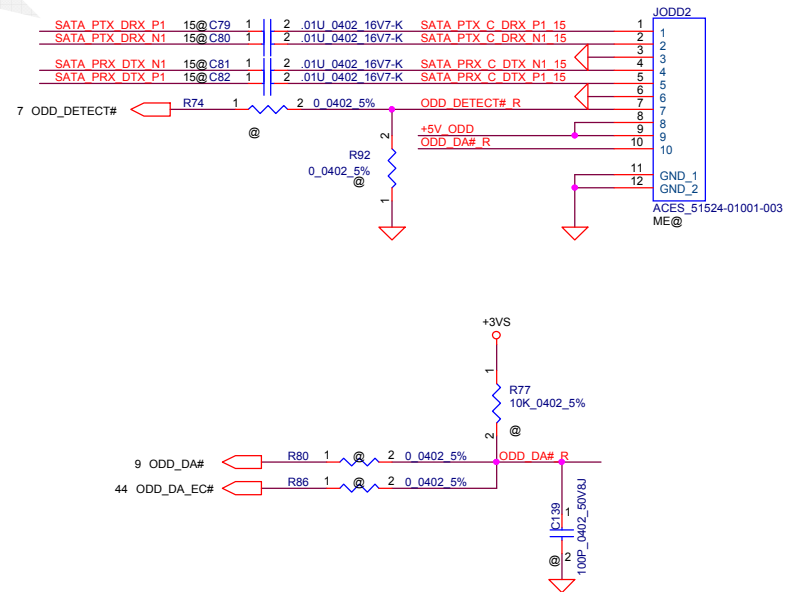

Security Classification		LC Future Center Secret Data	
Issued Date	2013/08/08	Deciphered Date	2013/08/05
THIS SHEET OF ENGINEERING DRAWING IS THE PROPRIETARY PROPERTY OF LC FUTURE CENTER, AND CONTAINS CONFIDENTIAL AND TRADE SECRET INFORMATION. THIS SHEET MAY NOT BE TRANSFERRED FROM THE CUSTODY OF THE COMPETENT DIVISION OF R&D DEPARTMENT EXCEPT AS AUTHORIZED BY LC FUTURE CENTER NEITHER THIS SHEET NOR THE INFORMATION IT CONTAINS MAY BE USED BY OR DISCLOSED TO ANY THIRD PARTY WITHOUT PRIOR WRITTEN CONSENT OF LC FUTURE CENTER.			

Title		
HDD/ODD CONN		
Size	Document Number	ACLU1 & ACLU2
Rev	1.0	
Date	Thursday, December 16, 2013	Sheet 42 of 59

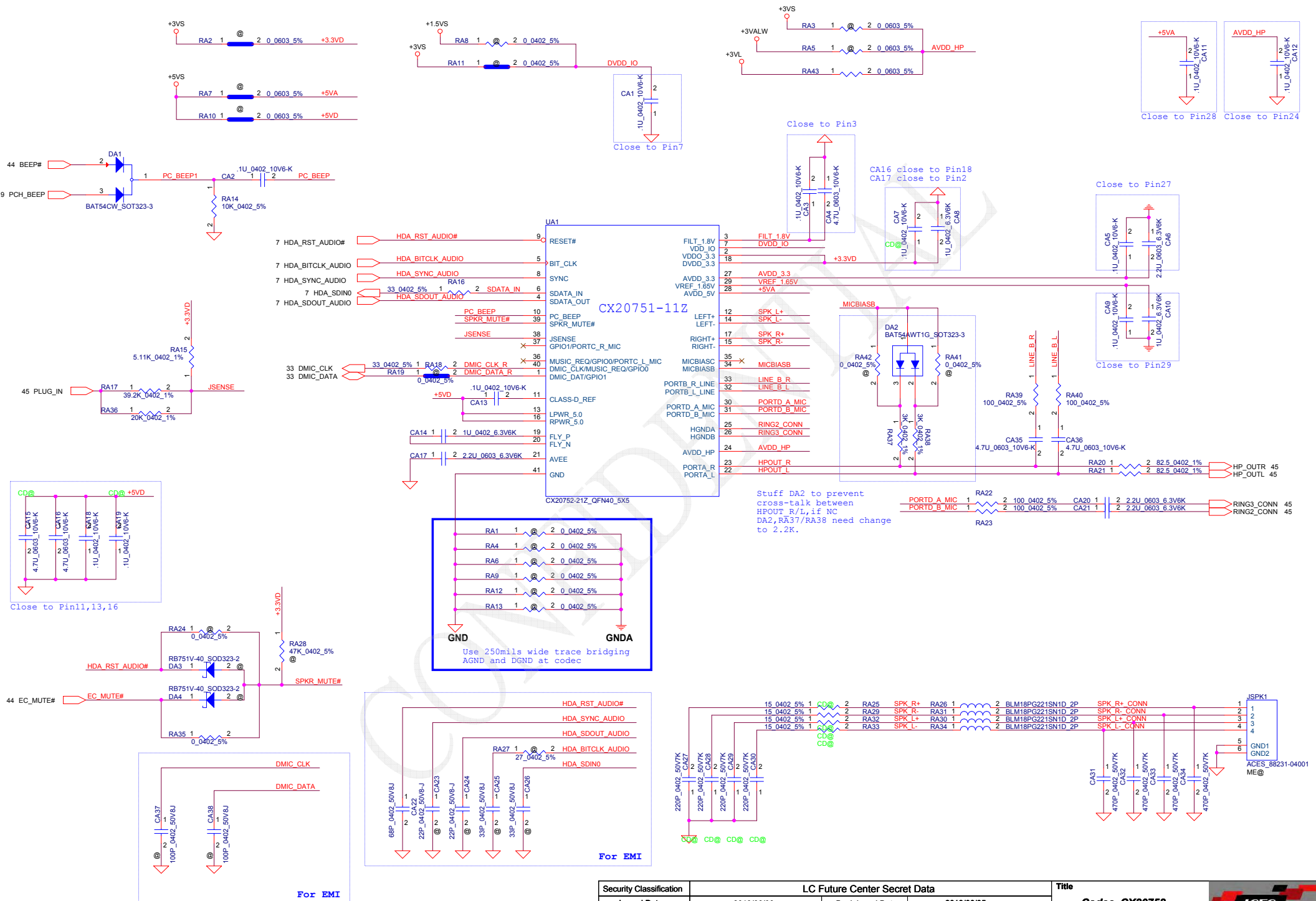

Security Classification	LC Future Center Secret Data	
Issued Date	2013/08/08	Deciphered Date
		2013/08/05

THIS SHEET OF ENGINEERING DRAWING IS THE PROPRIETARY PROPERTY OF LC FUTURE CENTER, AND CONTAINS CONFIDENTIAL AND TRADE SECRET INFORMATION. THIS SHEET MAY NOT BE TRANSFERRED FROM THE CUSTODY OF THE COMPETENT DIVISION OF DEPARTMENT EXCEPT AS AUTHORIZED BY LC FUTURE CENTER NEITHER THIS SHEET NOR THE INFORMATION IT CONTAINS MAY BE USED BY OR DISCLOSED TO ANY THIRD PARTY WITHOUT PRIOR WRITTEN CONSENT OF LC FUTURE CENTER.

Title	Revision
Codec_CX20752	1.0

ACLU1 & ACLU2

Date: Thursday, December 19, 2013 Sheet 43 of 59

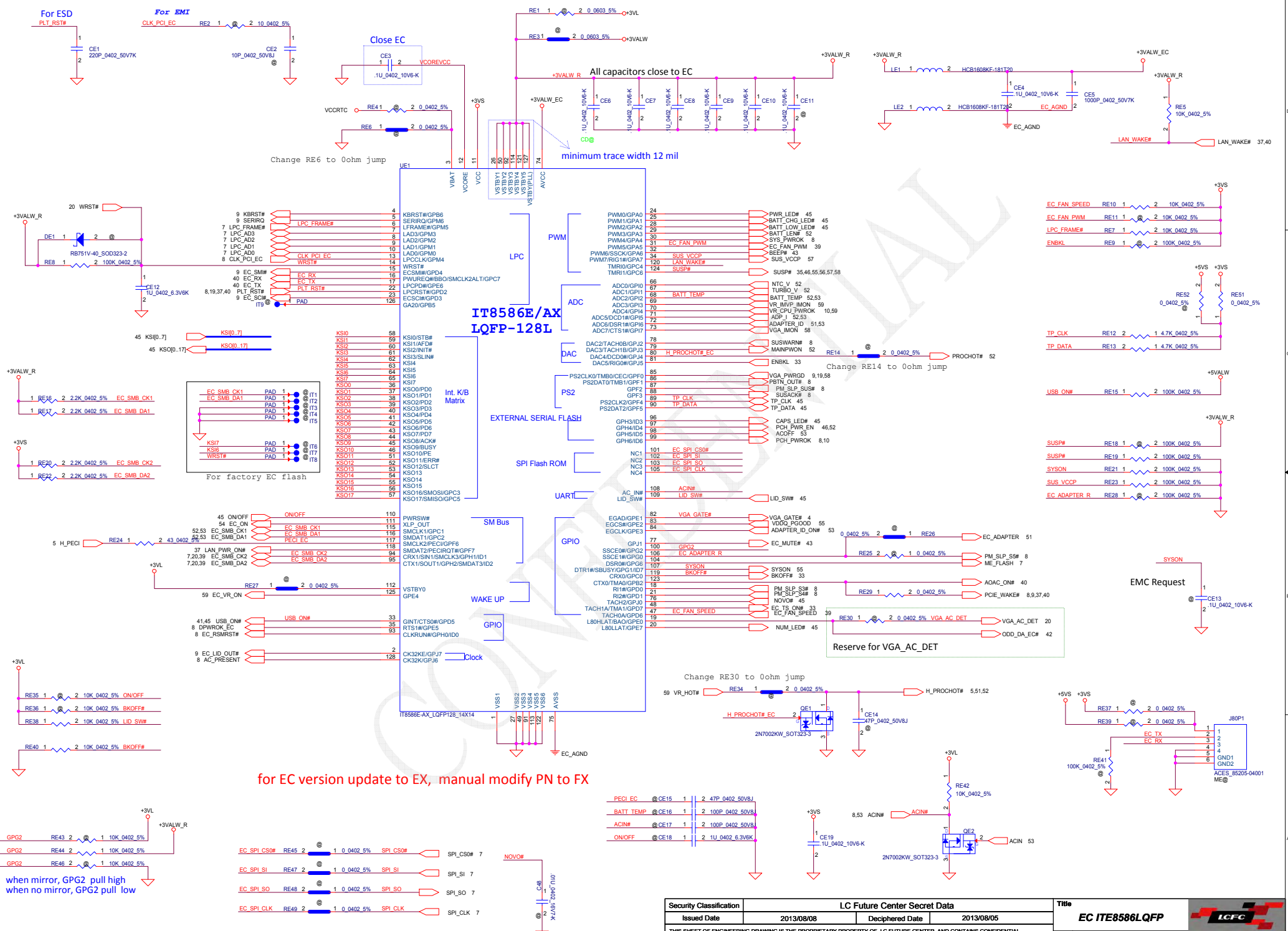

for EC version update to EX, manual modify PN to FX

Security Classification		LC Future Center Secret Data		Title	
Issued Date	2013/08/08	Deciphered Date	2013/08/05	EC ITE8586LQFP	
THIS SHEET OF ENGINEERING DRAWINGS IS THE PROPRIETARY PROPERTY OF LC FUTURE CENTER AND CONTAINS CONFIDENTIAL AND TRADE SECRET INFORMATION. THIS SHEET MAY NOT BE TRANSFERRED FROM THE CUSTODY OF THE COMPETENT DIVISION OF R&D DEPARTMENT EXCEPT AS AUTHORIZED BY LC FUTURE CENTER. NEITHER THIS SHEET NOR THE INFORMATION IT CONTAINS MAY BE USED BY OR DISCLOSED TO ANY THIRD PARTY WITHOUT PRIOR WRITTEN CONSENT OF LC FUTURE CENTER.					
Size	C	Document Number	ACL01 & ACL02	Rev	1.0
Date:	Thursday, December 19, 2013	Sheet	44	of	59

ON/OFF switch

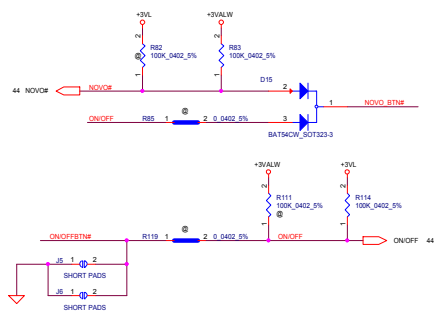

K/B Connector

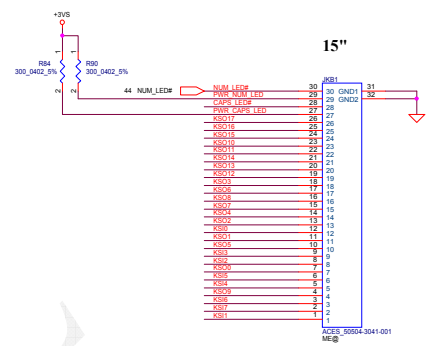
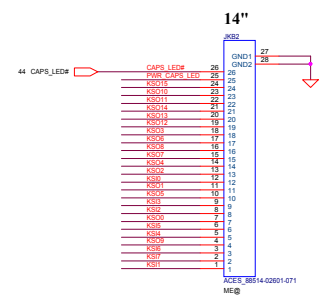
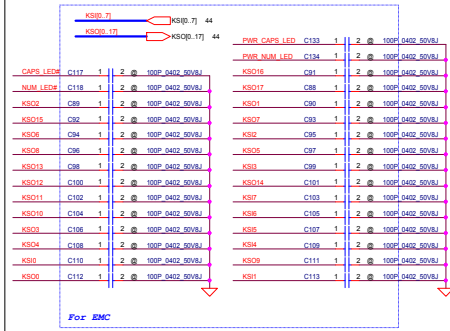

TP/B Connector

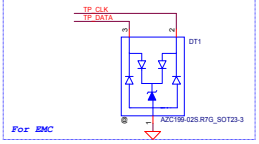
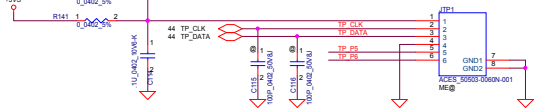

For 14"		For 15"	
1	VDD	1	VDD
2	CLK	2	CLK
3	DAT	3	DAT
4	GND	4	GND
5	TP-L	5	TP-L
6	TP-R	6	TP-R

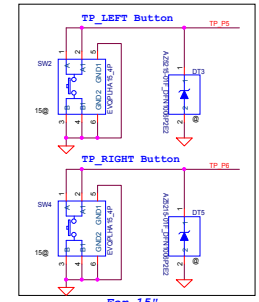
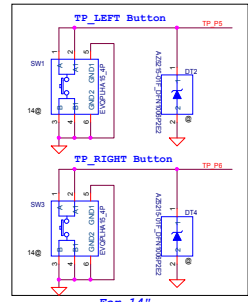

PWR/B Connector

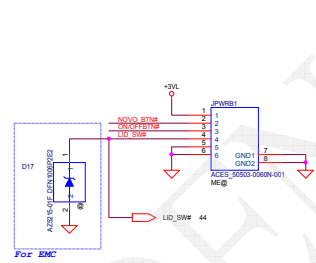

Right Side USB2.0 Port X 1 (USB/B)

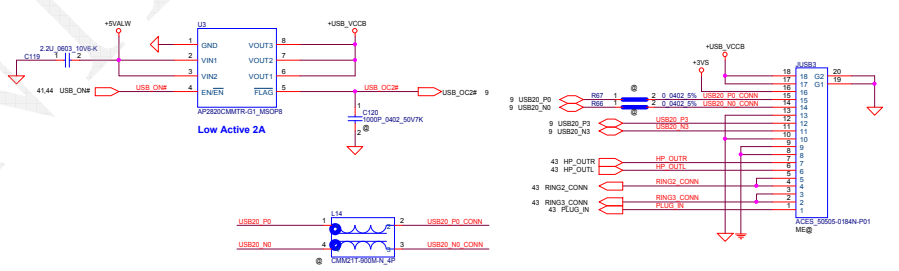

LED

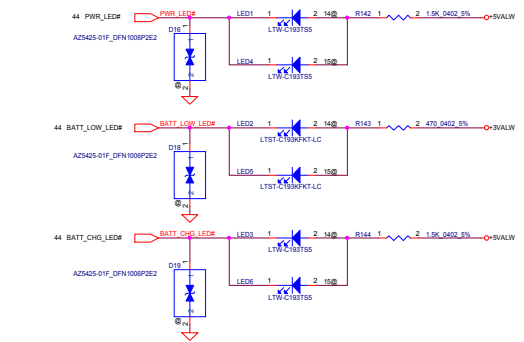

+5VALW to +5VS

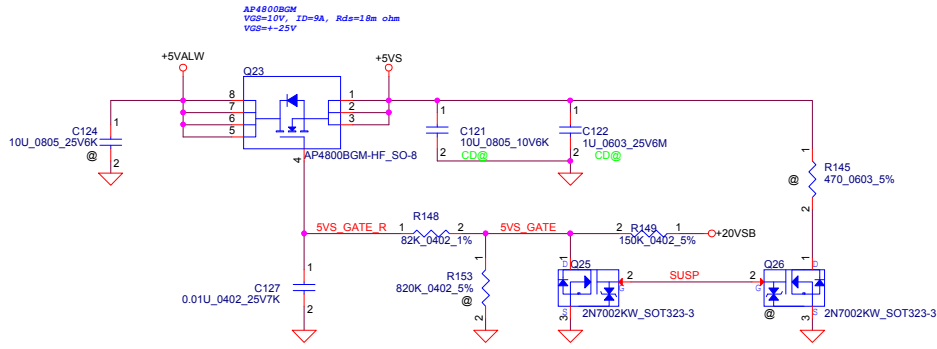

+3VALW to +3VS

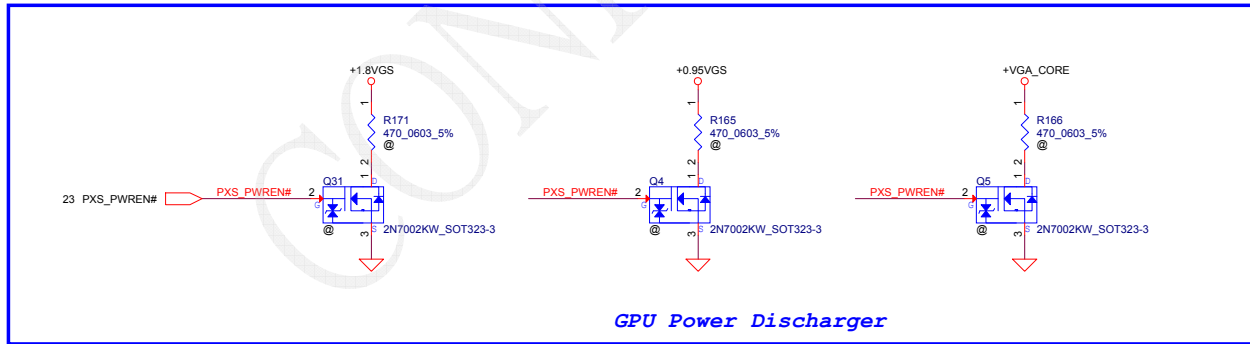
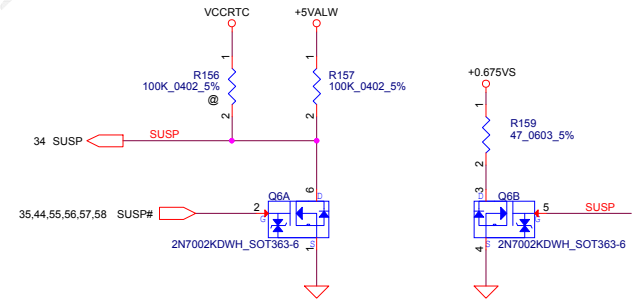
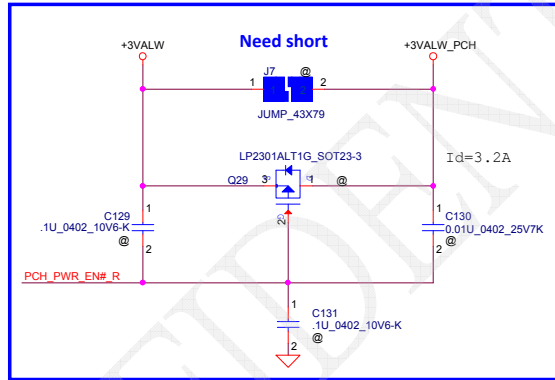
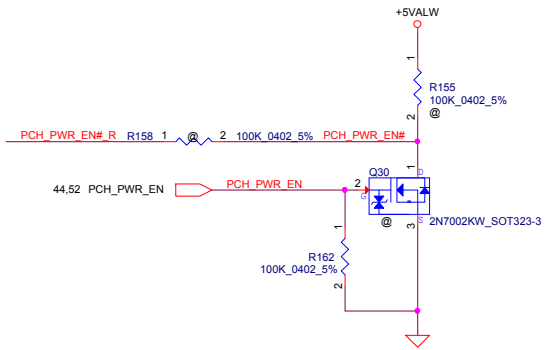
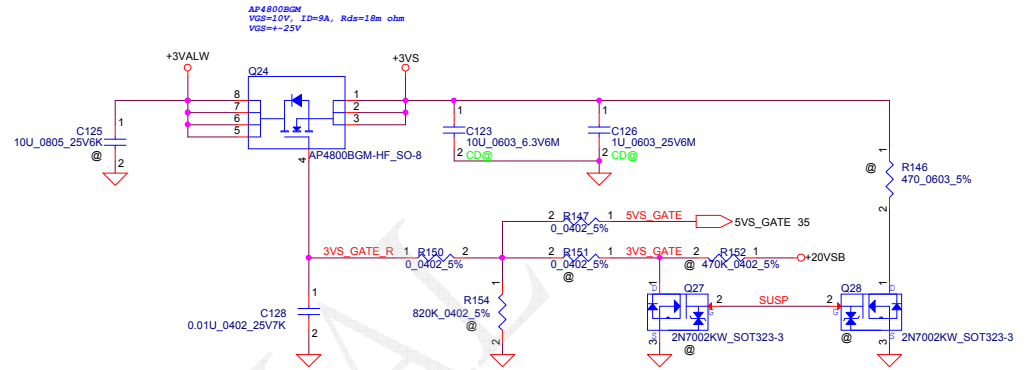

GPU Power Discharger

Security Classification	LC Future Center Secret Data		Title	
Issued Date	2013/08/08	Deciphered Date	2013/08/05	
THIS SHEET OF ENGINEERING DRAWING IS THE PROPRIETARY PROPERTY OF LC FUTURE CENTER, AND CONTAINS CONFIDENTIAL AND TRADE SECRET INFORMATION. THIS SHEET MAY NOT BE TRANSFERRED FROM THE CUSTODY OF THE COMPETENT DIVISION OF THE DEPARTMENT EXCEPT AS AUTHORIZED BY LC FUTURE CENTER. NEITHER THIS SHEET NOR THE INFORMATION IT CONTAINS MAY BE USED BY OR DISCLOSED TO ANY THIRD PARTY WITHOUT PRIOR WRITTEN CONSENT OF LC FUTURE CENTER.				Size: Custom Document Number: ACLU1 & ACLU2 Date: Thursday, December 19, 2013 Sheet 46 of 59

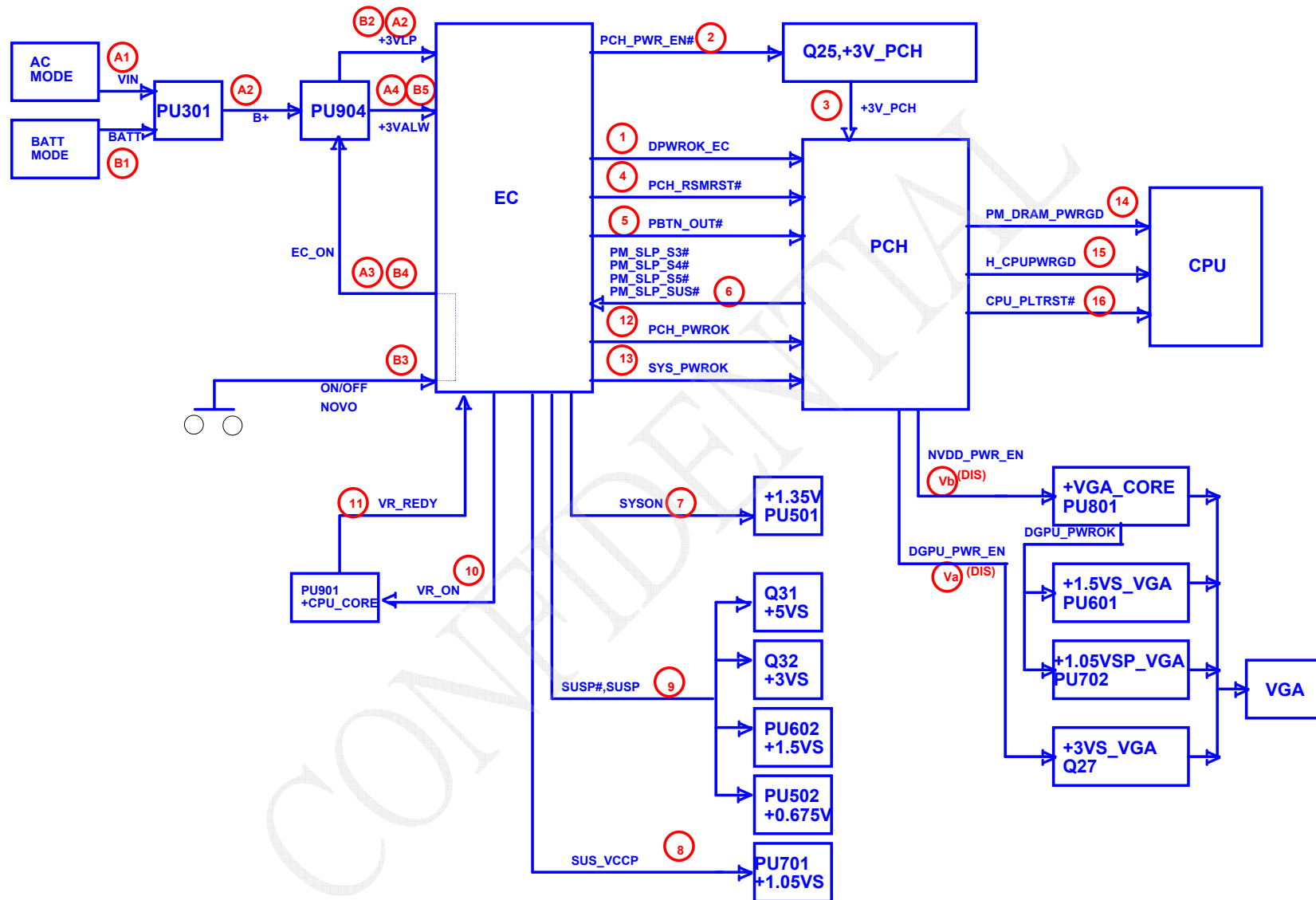

Security Classification	LC Future Center Secret Data		
Issued Date	2013/08/08	Deciphered Date	2013/08/05

Title	Power sequence Block
-------	----------------------

THIS SHEET OF ENGINEERING DRAWING IS THE PROPRIETARY PROPERTY OF LC FUTURE CENTER, AND CONTAINS CONFIDENTIAL AND TRADE SECRET INFORMATION. THIS SHEET MAY NOT BE TRANSFERRED FROM THE CUSTODY OF THE COMPETENT DIVISION OF DEPARTMENT EXCEPT AS AUTHORIZED BY LC FUTURE CENTER. NEITHER THIS SHEET NOR THE INFORMATION IT CONTAINS MAY BE USED BY OR DISCLOSED TO ANY THIRD PARTY WITHOUT PRIOR WRITTEN CONSENT OF LC FUTURE CENTER.

Document Number	ACL01 & ACL02	Rev	1.0
Date:	Thursday, December 19, 2013	Sheet	47 of 59



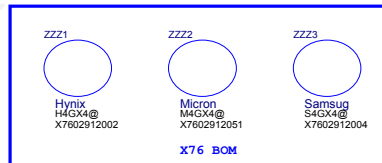
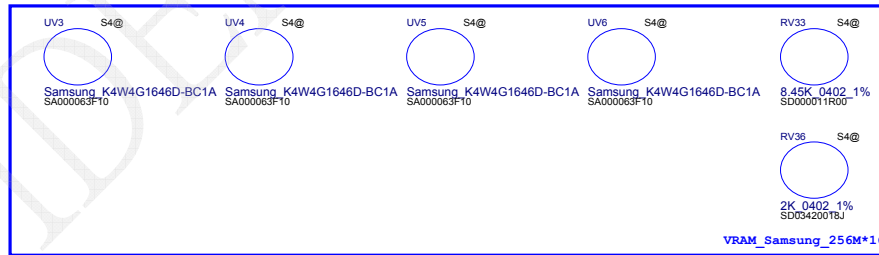
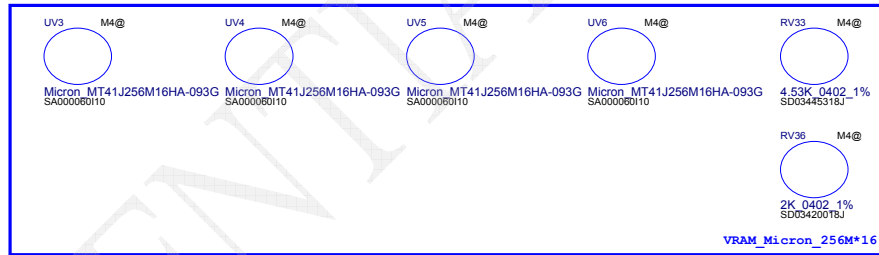
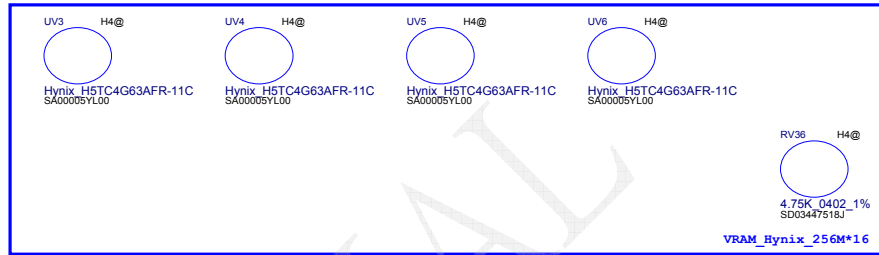
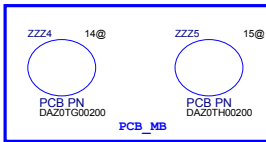
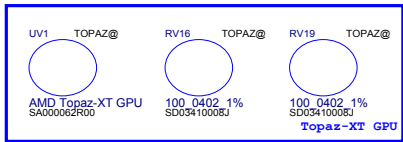
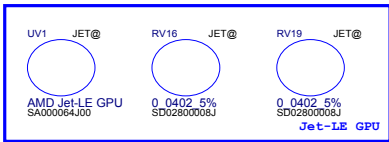
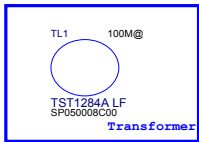
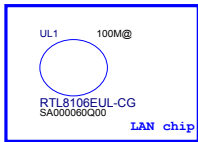

Board ID

BOARD_ID0	BOARD_ID1	BOARD_ID2	BOARD_ID3	Description	Stuff Resistor
0	0	0	0	14" + Jet-LE sku	RC107,RC108,RC109,RC123
0	1	0	0	15" + Jet-LE sku	RC107,RC101,RC109,RC123
1	0	0	0	14" + Topaz-XT sku	RC100,RC108,RC109,RC123
1	1	0	0	15" + Topaz-XT sku	RC100,RC101,RC109,RC123

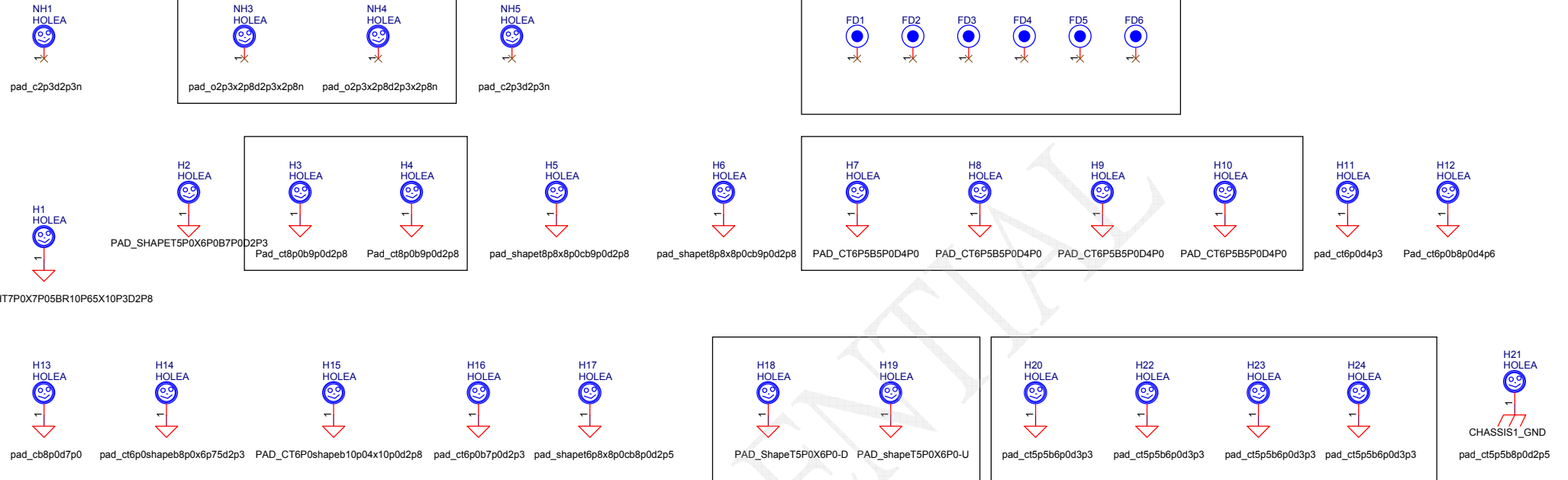

FFC CONN GROUND PAD

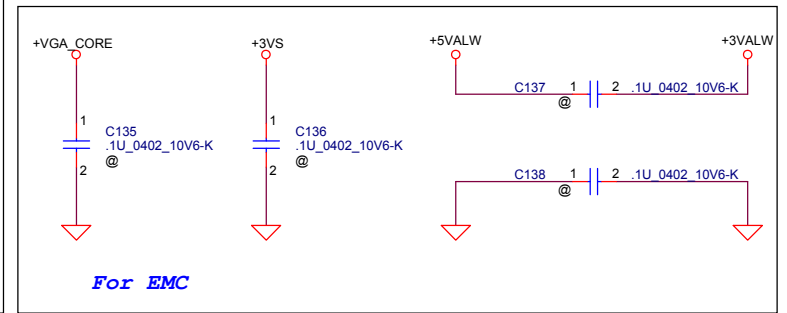

Security Classification	LC Future Center Secret Data			Title	Hole
Issued Date	2013/08/08	Deciphered Date	2013/08/05	Document Number	
THIS SHEET OF ENGINEERING DRAWING IS THE PROPRIETARY PROPERTY OF LC FUTURE CENTER. AND CONTAINS CONFIDENTIAL AND TRADE SECRET INFORMATION. THIS SHEET MAY NOT BE TRANSFERRED FROM THE CUSTODY OF THE COMPETENT DIVISION OF R&D DEPARTMENT EXCEPT AS AUTHORIZED BY LC FUTURE CENTER NEITHER THIS SHEET NOR THE INFORMATION IT CONTAINS MAY BE USED BY OR DISCLOSED TO ANY THIRD PARTY WITHOUT PRIOR WRITTEN CONSENT OF LC FUTURE CENTER.				Size B	Rev 1.0
				Date: Thursday, December 19, 2013	Sheet 49 of 59



ACLUI & ACLU2

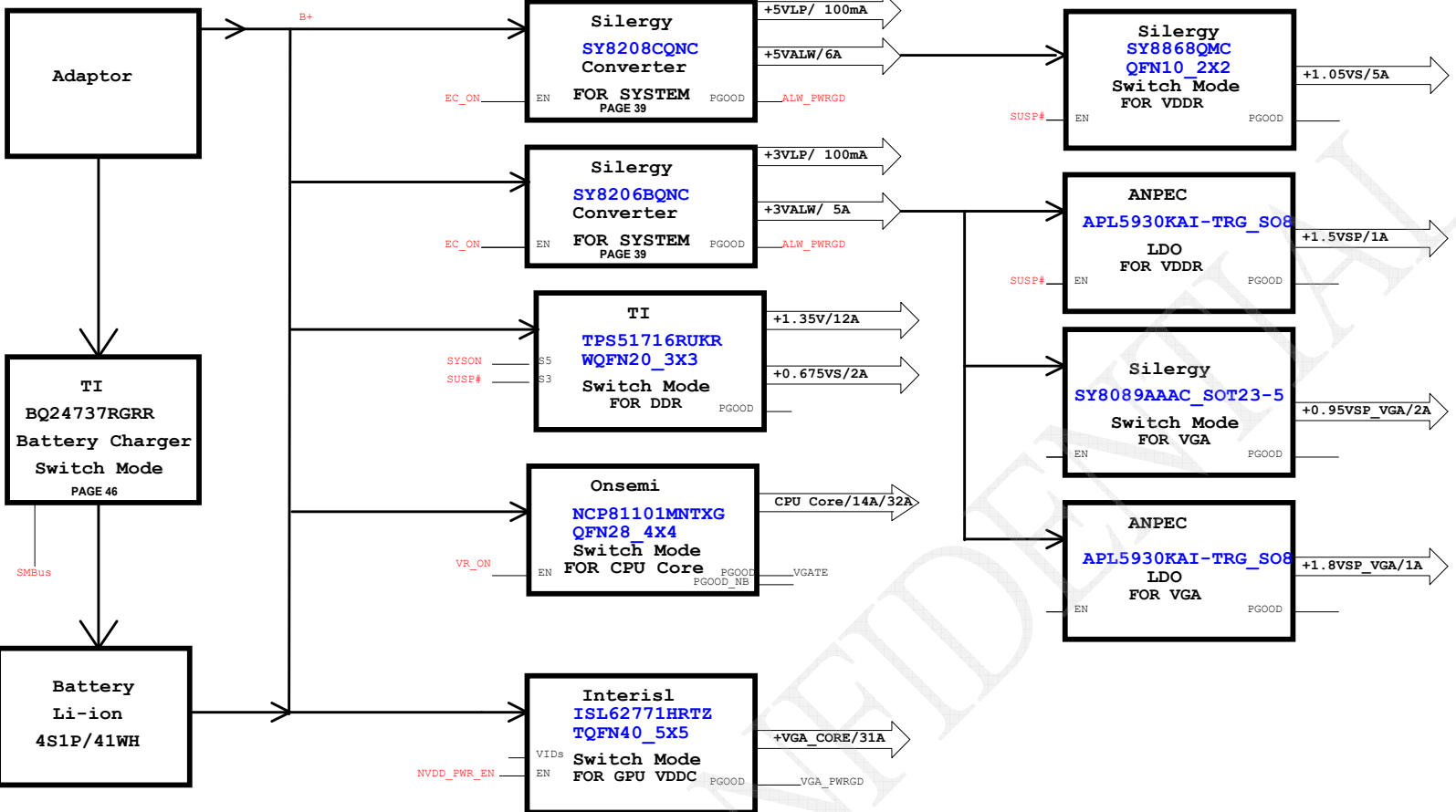

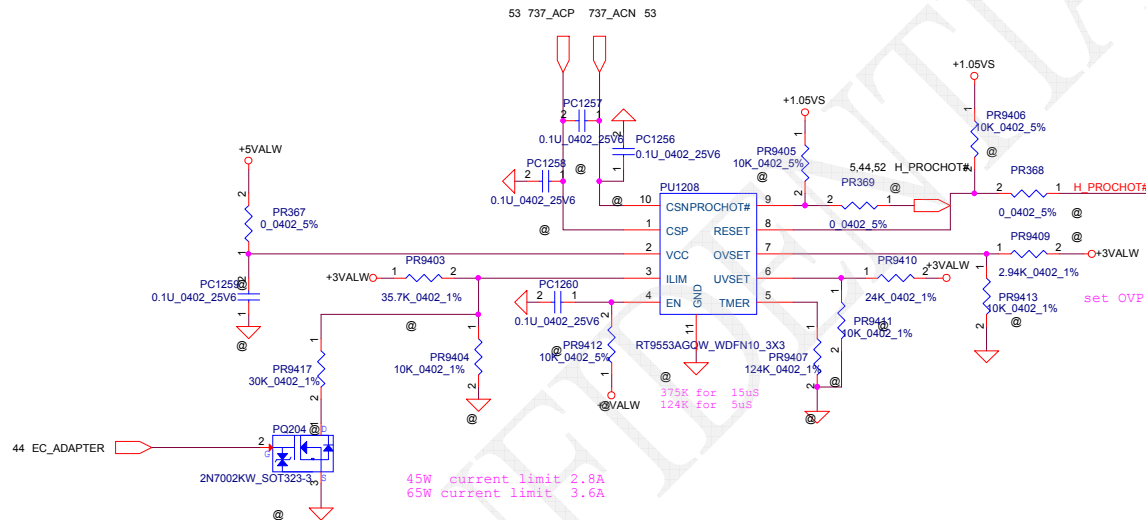
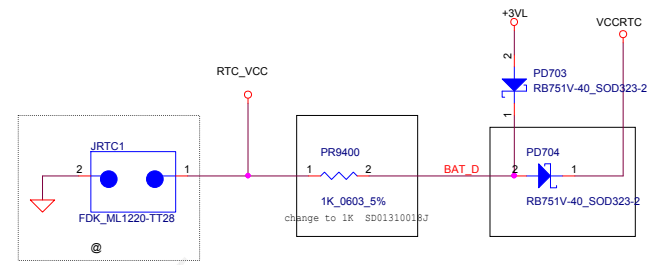
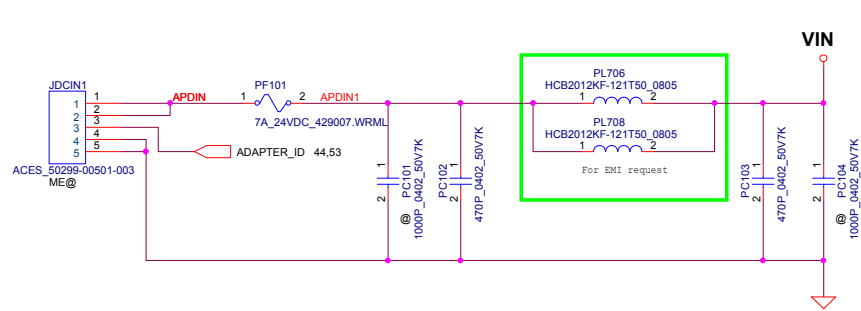

Security Classification	LC Future Center Secret Data		
Issued Date	2013/08/08	Deciphered Date	2013/08/05
THIS SHEET OF ENGINEERING DRAWING IS THE PROPRIETARY PROPERTY OF LC FUTURE CENTER, AND CONTAINS CONFIDENTIAL AND TRADE SECRET INFORMATION. THIS SHEET MAY NOT BE TRANSFERRED FROM THE CUSTODY OF THE COMPETENT DIVISION OF DEPARTMENT EXCEPT AS AUTHORIZED BY LC FUTURE CENTER. NEITHER THIS SHEET NOR THE INFORMATION IT CONTAINS MAY BE USED BY OR DISCLOSED TO ANY THIRD PARTY WITHOUT PRIOR WRITTEN CONSENT OF LC FUTURE CENTER.			

Title	DCIN / RTC		
Size	Document Number	Rev	1.0
Date:	Thursday, December 19, 2013 Sheet 51 of 59		



ACL1 & ACL2

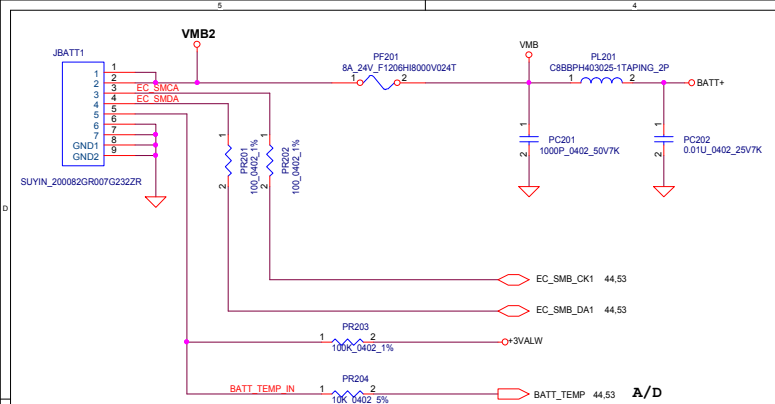

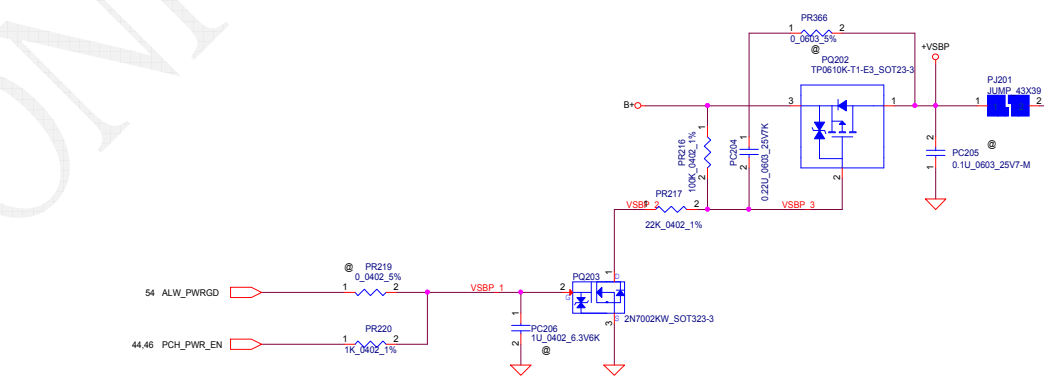
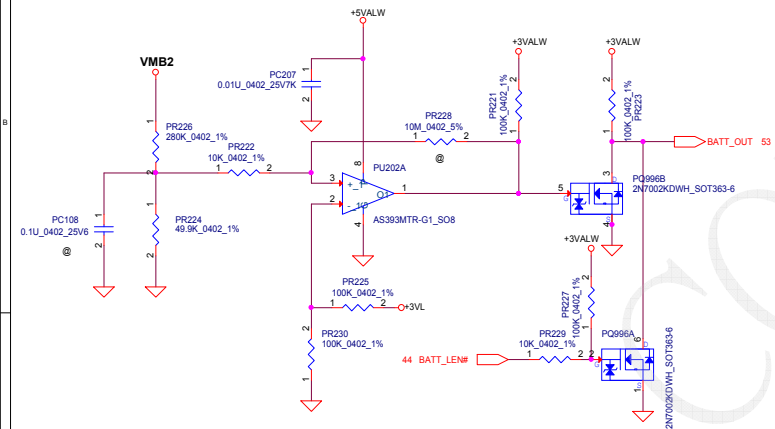
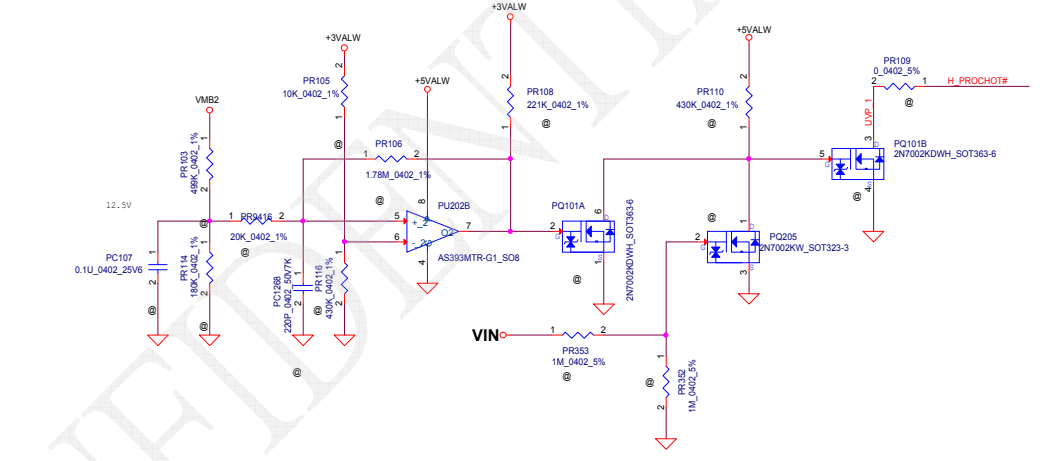
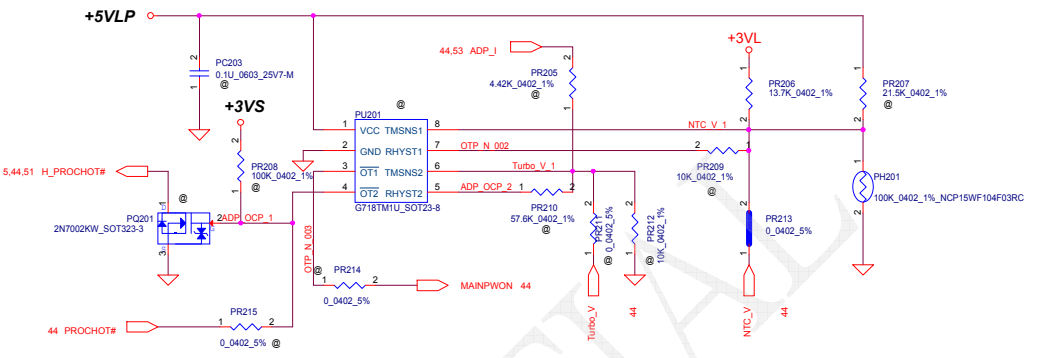
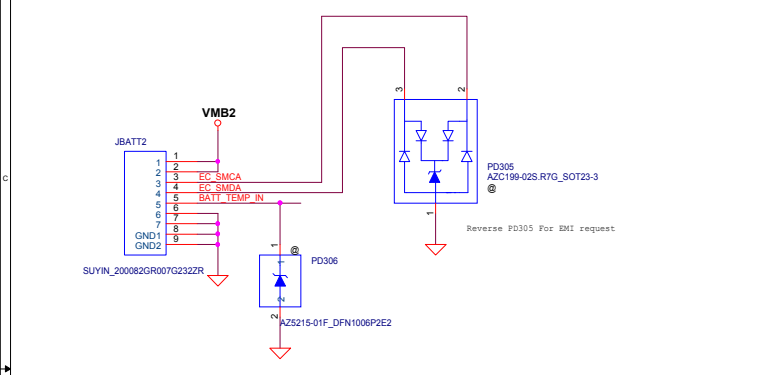

PH201 under CPU bottom side :
CPU thermal protection at 92+3 degree C
Recovery at 56 +3 degree C

For KB930 --> Keep PU1 circuit (Vth = 0.825V)
For KB9012 (Red square) --> Remove PU201 circuit, but keep PR206, PH201, PR205, PR211, PQ201, PR208, PR212

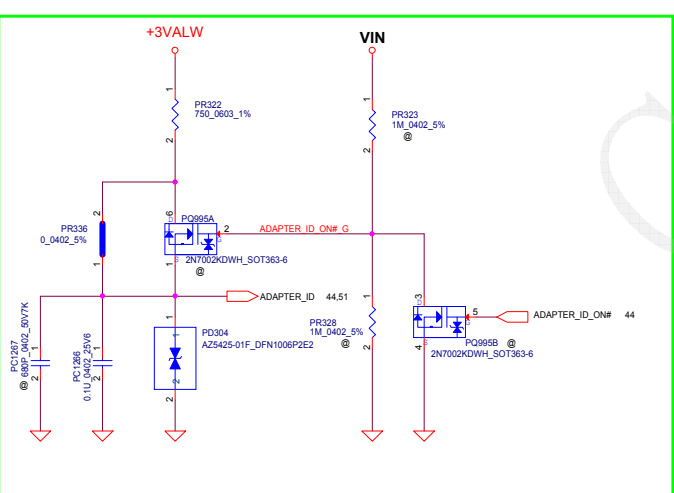
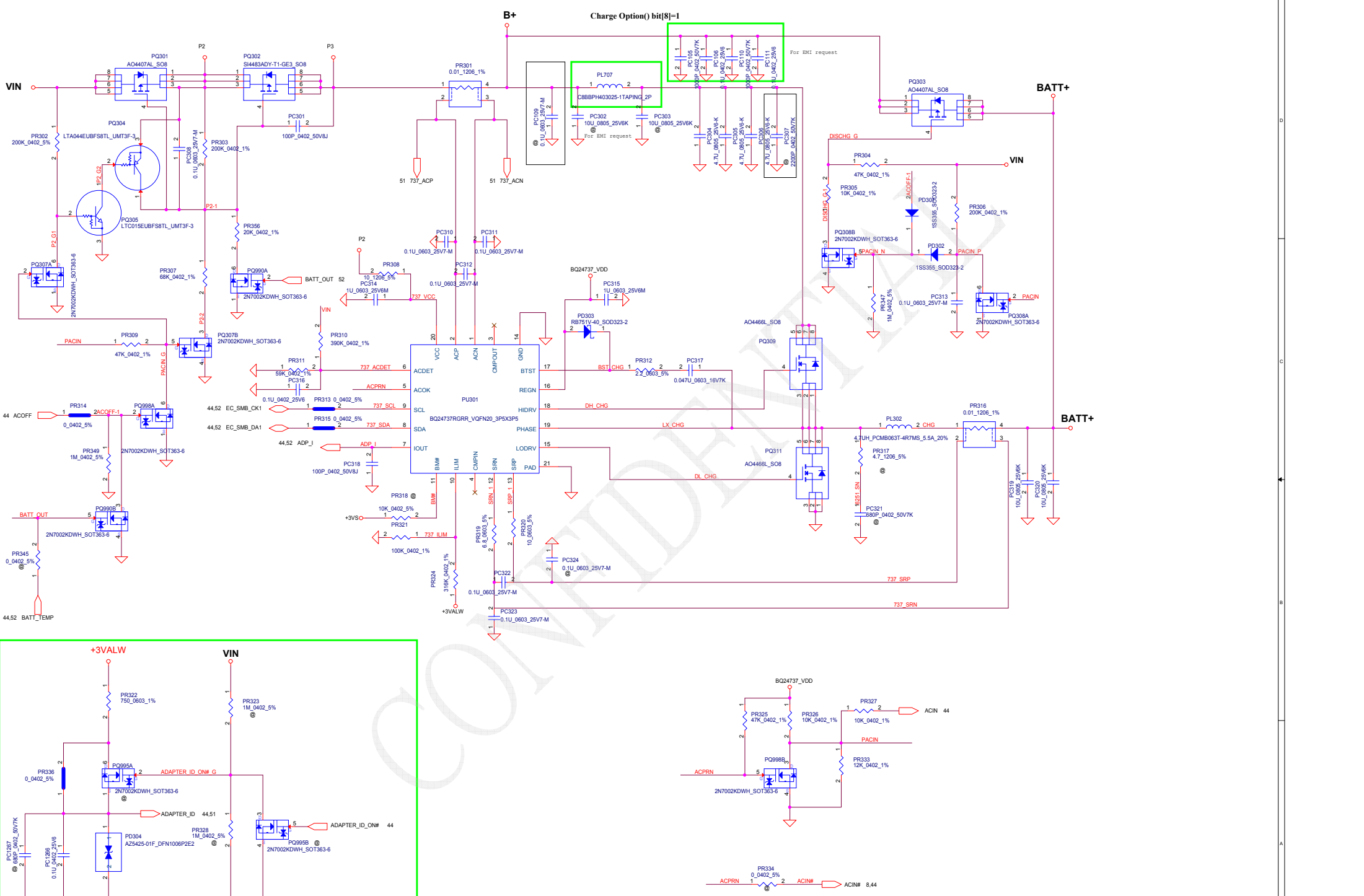

Security Classification	LC Future Center Secret Data		Title		
Issued Date	2013/08/08	Deciphered Date	2013/08/05		BATTERY CONN/OTP
THIS SHEET OF ENGINEERING DRAWINGS IS THE PROPRIETARY PROPERTY OF LC FUTURE CENTER AND CONTAINS CONFIDENTIAL AND TRADE SECRET INFORMATION. THIS SHEET MAY NOT BE TRANSFERRED FROM THE CUSTODY OF THE COMPETENT DIVISION OF R&D DEPARTMENT EXCEPT AS AUTHORIZED BY LC FUTURE CENTER. NEITHER THIS SHEET NOR THE INFORMATION IT CONTAINS MAY BE USED BY OR DISCLOSED TO ANY THIRD PARTY WITHOUT PRIOR WRITTEN CONSENT OF LC FUTURE CENTER.					
Size	Document Number	Rev		1.0	
Date:	Thursday, December 18, 2013	Sheet	52	of	59



Security Classification	LC Future Center Secret Data		Title	
Issued Date	2013/08/08	Deciphered Date	2013/08/05	
THIS SHEET OF ENGINEERING DRAWING IS THE PROPRIETARY PROPERTY OF LC FUTURE CENTER AND CONTAINS CONFIDENTIAL AND TRADE SECRET INFORMATION. THIS SHEET MAY NOT BE TRANSFERRED FROM THE CUSTODY OF THE COMPETENT DIVISION OF R&D DEPARTMENT EXCEPT AS AUTHORIZED BY LC FUTURE CENTER. NEITHER THIS SHEET NOR THE INFORMATION IT CONTAINS MAY BE USED BY OR DISCLOSED TO ANY THIRD PARTY WITHOUT PRIOR WRITTEN CONSENT OF LC FUTURE CENTER.				Size Document Number ACL01 & ACL02 Rev 1.0
Date:	Friday, December 20, 2013	Sheet	53	of 59

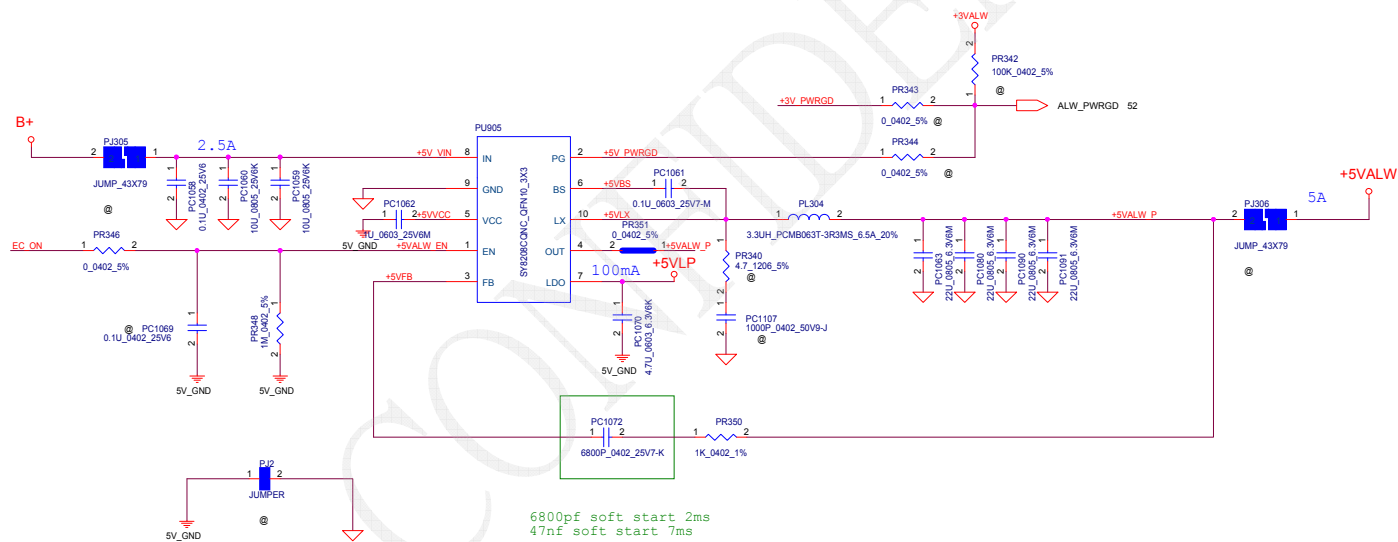
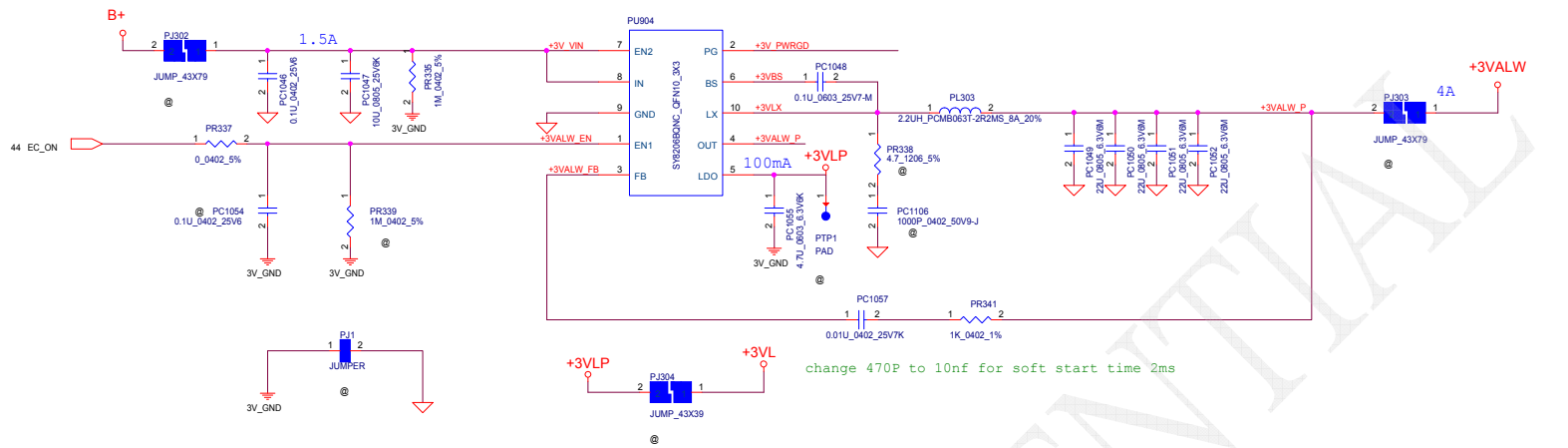

Security Classification	LC Future Center Secret Data		Title	
Issued Date	2013/08/08	Deciphered Date	2013/08/05	
<small>THIS SHEET OF ENGINEERING DRAWING IS THE PROPRIETARY PROPERTY OF LC FUTURE CENTER AND CONTAINS CONFIDENTIAL AND TRADE SECRET INFORMATION. THIS SHEET MAY NOT BE TRANSFERRED FROM THE CUSTODY OF THE COMPETENT DIVISION OF R&D DEPARTMENT EXCEPT AS AUTHORIZED BY LC FUTURE CENTER. NEITHER THIS SHEET NOR THE INFORMATION IT CONTAINS MAY BE USED BY OR DISCLOSED TO ANY THIRD PARTY WITHOUT PRIOR WRITTEN CONSENT OF LC FUTURE CENTER.</small>				Size Document Number ACL01 & ACL02
Date:	Thursday, December 19, 2013	Sheet	54	of 59

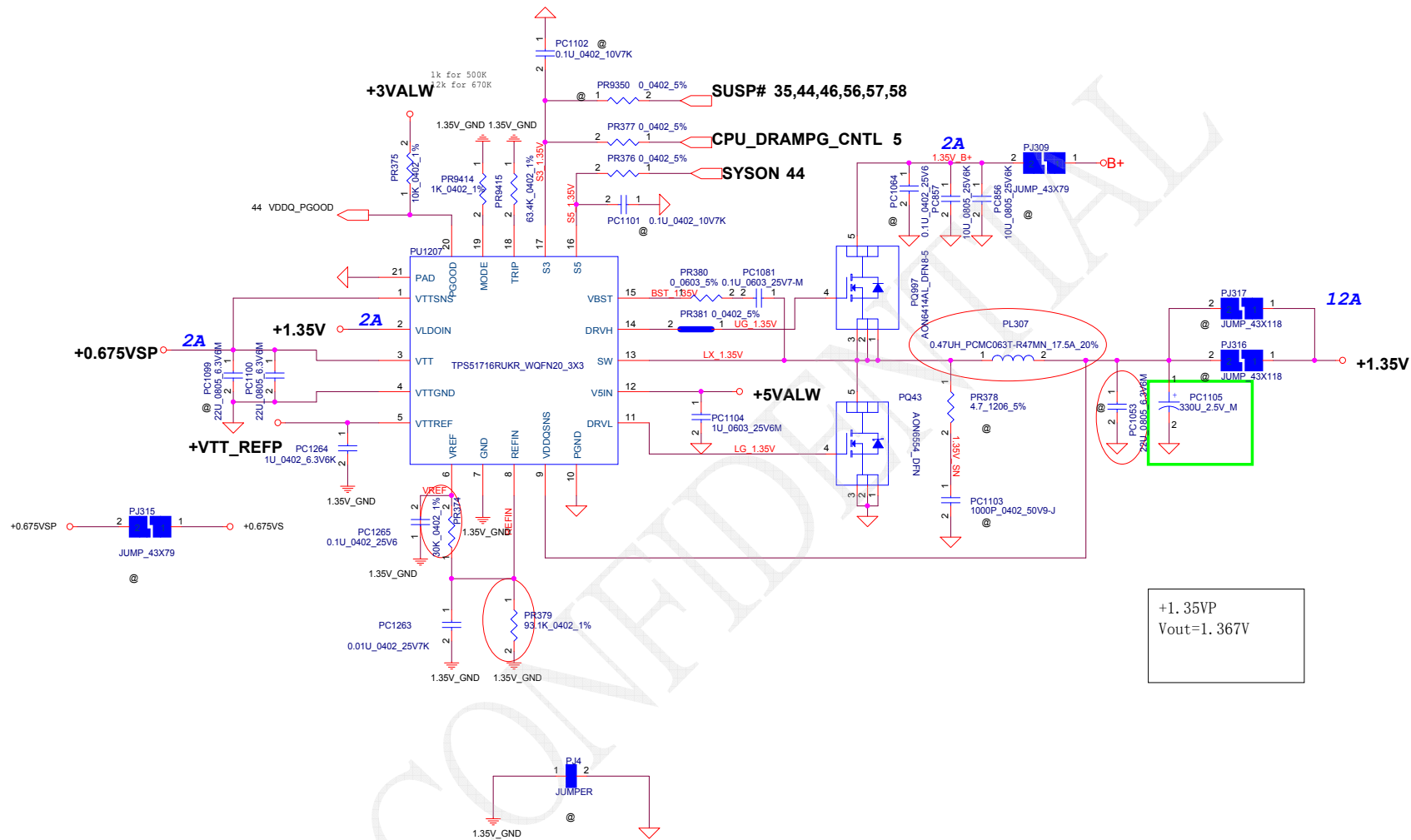

Security Classification	LC Future Center Secret Data		
Issued Date	2013/08/08	Deciphered Date	2013/08/05
THIS SHEET OF ENGINEERING DRAWING IS THE PROPRIETARY PROPERTY OF LC FUTURE CENTER, AND CONTAINS CONFIDENTIAL AND TRADE SECRET INFORMATION. THIS SHEET MAY NOT BE TRANSFERRED FROM THE CUSTODY OF THE COMPETENT DIVISION OF R&D DEPARTMENT EXCEPT AS AUTHORIZED BY LC FUTURE CENTER. NEITHER THIS SHEET NOR THE INFORMATION IT CONTAINS MAY BE USED BY OR DISCLOSED TO ANY THIRD PARTY WITHOUT PRIOR WRITTEN CONSENT OF LC FUTURE CENTER.			

Title		
1.35VS/+0.675VS		
Size Custom	Document Number	Rev 1.0
Date: Thursday, December 18, 2013		Sheet 55 of 59

ACLU1 & ACLU2

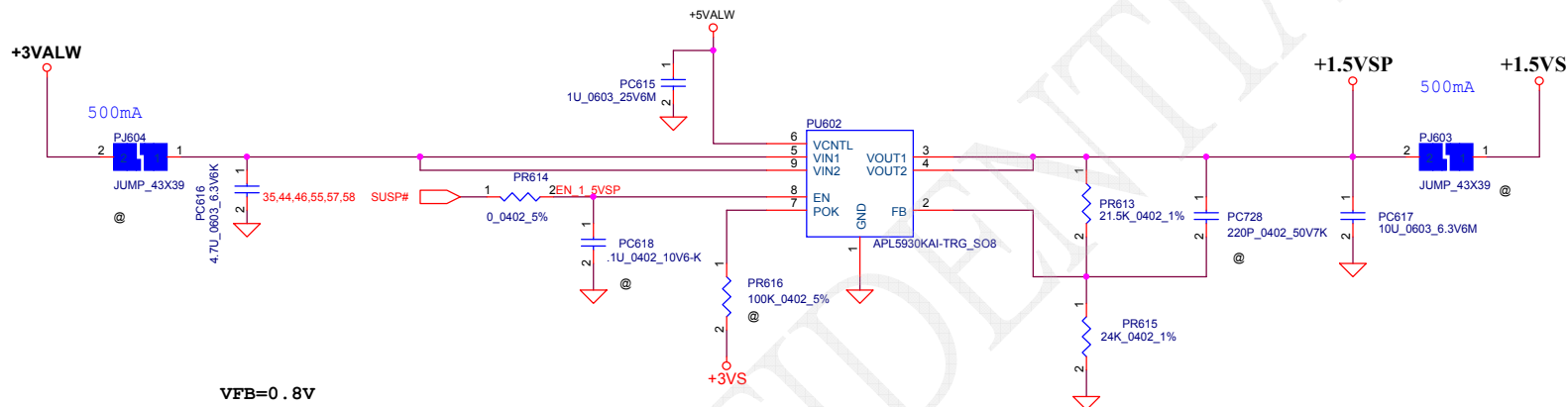

VFB=0.8V

Security Classification	LC Future Center Secret Data		
Issued Date	2013/08/08	Deciphered Date	2013/08/05
THIS SHEET OF ENGINEERING DRAWING IS THE PROPRIETARY PROPERTY OF LC FUTURE CENTER, AND CONTAINS CONFIDENTIAL AND TRADE SECRET INFORMATION. THIS SHEET MAY NOT BE TRANSFERRED FROM THE CUSTODY OF THE COMPETENT DIVISION OF R&D DEPARTMENT EXCEPT AS AUTHORIZED BY LC FUTURE CENTER NEITHER THIS SHEET NOR THE INFORMATION IT CONTAINS MAY BE USED BY OR DISCLOSED TO ANY THIRD PARTY WITHOUT PRIOR WRITTEN CONSENT OF LC FUTURE CENTER.			

Title		
+1.5VS/+1.8VGS		
Size	Document Number	Rev
Custom	ACLU1 & ACLU2	1.0
Date:	Thursday, December 19, 2013	Sheet 56 of 59

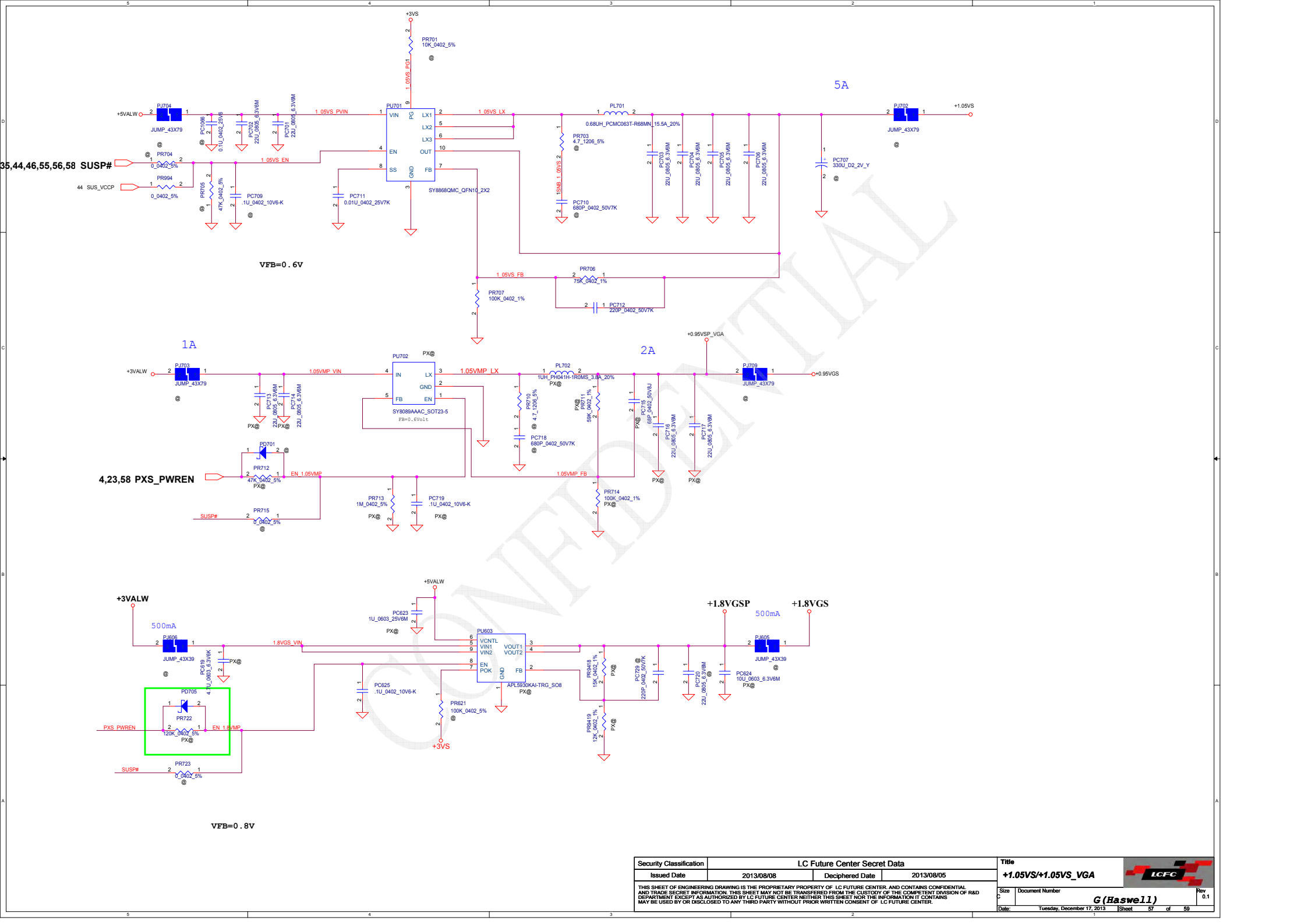

35,44,46,55,56,58 SUSP#

VFB=0.6V

1A

2A

4,23,58 PXS_PWREN

VFB=0.8V

Security Classification	LC Future Center Secret Data		Title
Issued Date	2013/08/08	Deciphered Date	2013/08/05
THIS SHEET OF ENGINEERING DRAWINGS IS THE PROPRIETARY PROPERTY OF LC FUTURE CENTER AND CONTAINS CONFIDENTIAL AND TRADE SECRET INFORMATION. THIS SHEET MAY NOT BE TRANSFERRED FROM THE CUSTODY OF THE COMPETENT DIVISION OF R&D DEPARTMENT EXCEPT AS AUTHORIZED BY LC FUTURE CENTER. NEITHER THIS SHEET NOR THE INFORMATION IT CONTAINS MAY BE USED BY OR DISCLOSED TO ANY THIRD PARTY WITHOUT PRIOR WRITTEN CONSENT OF LC FUTURE CENTER.			+1.05VS/+1.05VS_VGA  G (Haswell) Rev 0.1
Size	Document Number	Date	Tuesday, December 17, 2013
C		Sheet	57 of 59

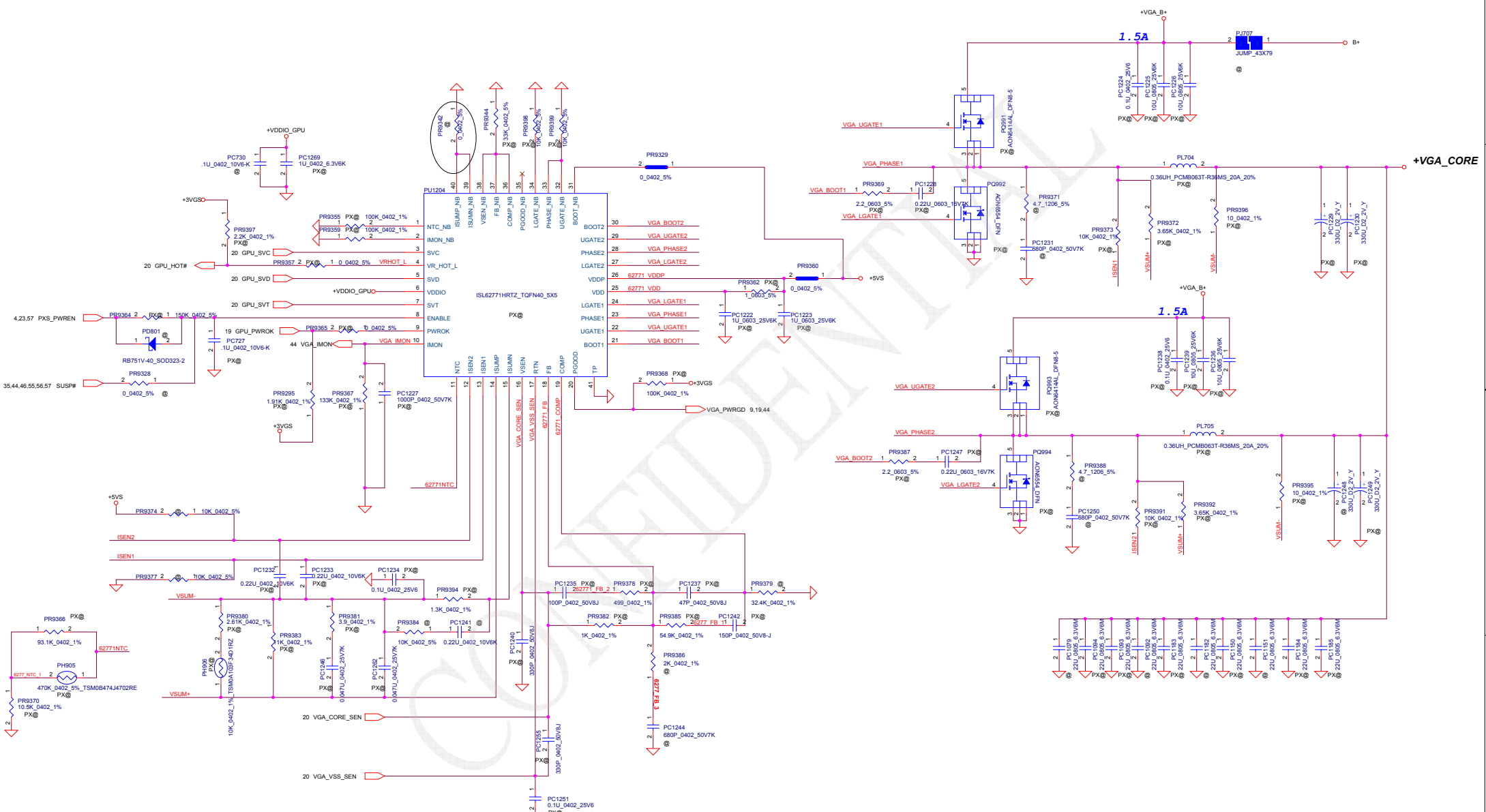

Security Classification	LC Future Center Secret Data		Title	
Issued Date	2013/08/08	Deciphered Date	2013/08/05	
Document Number	PWR-VGA_CORE			Rev
Revision	1.0			1.0
Date	Friday, December 20, 2013			Sheet
Page	58			of
				59

THIS SHEET OF ENGINEERING DRAWING IS THE PROPRIETARY PROPERTY OF LC FUTURE CENTER, AND CONTAINS CONFIDENTIAL AND TRADE SECRET INFORMATION. THIS SHEET MAY NOT BE TRANSFERRED FROM THE CUSTODY OF THE COMPETENT DIVISION OF DEPARTMENT EXCEPT AS AUTHORIZED BY LC FUTURE CENTER. NEITHER THIS SHEET NOR THE INFORMATION IT CONTAINS MAY BE USED BY OR DISCLOSED TO ANY THIRD PARTY WITHOUT PRIOR WRITTEN CONSENT OF LC FUTURE CENTER.

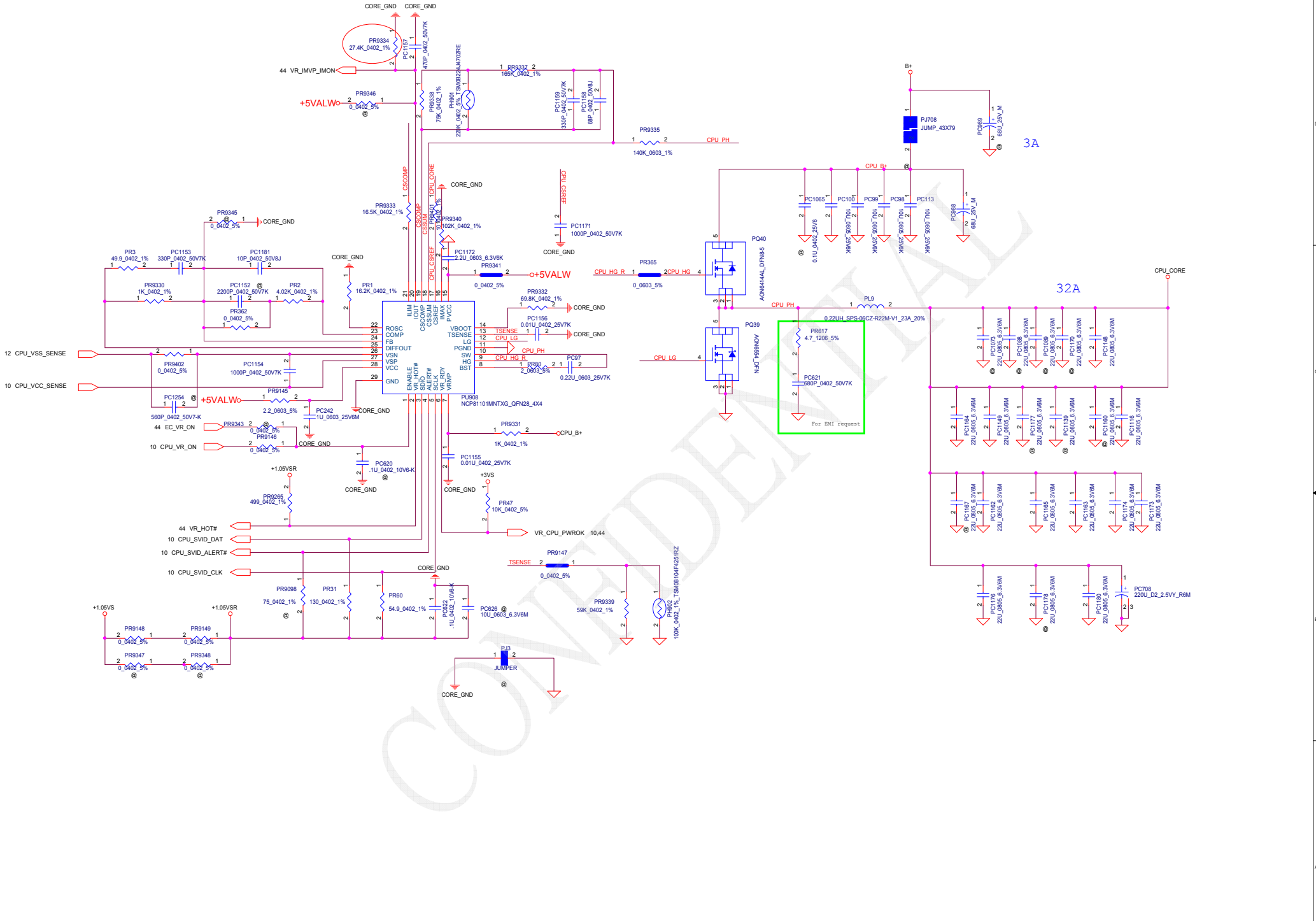

Security Classification	LC Future Center Secret Data		Title	 PWR_CPU Core
Issued Date	2013/08/08	Deciphered Date	2013/08/05	
<small>THIS SHEET OF ENGINEERING DRAWINGS IS THE PROPRIETARY PROPERTY OF LC FUTURE CENTER AND CONTAINS CONFIDENTIAL AND TRADE SECRET INFORMATION. THIS SHEET MAY NOT BE TRANSFERRED FROM THE CUSTODY OF THE COMPETENT DIVISION OF R&D DEPARTMENT EXCEPT AS AUTHORIZED BY LC FUTURE CENTER. NEITHER THIS SHEET NOR THE INFORMATION IT CONTAINS MAY BE USED BY OR DISCLOSED TO ANY THIRD PARTY WITHOUT PRIOR WRITTEN CONSENT OF LC FUTURE CENTER.</small>				Size: Document Number ACLUI & ACLU2 Rev: 1.0
Date:	Thursday, December 19, 2013	Sheet	59	of 59