

YK ,Deugging Guide

- william Peng
- 5/13/2004

Y-note Block diagram

Y-Note :

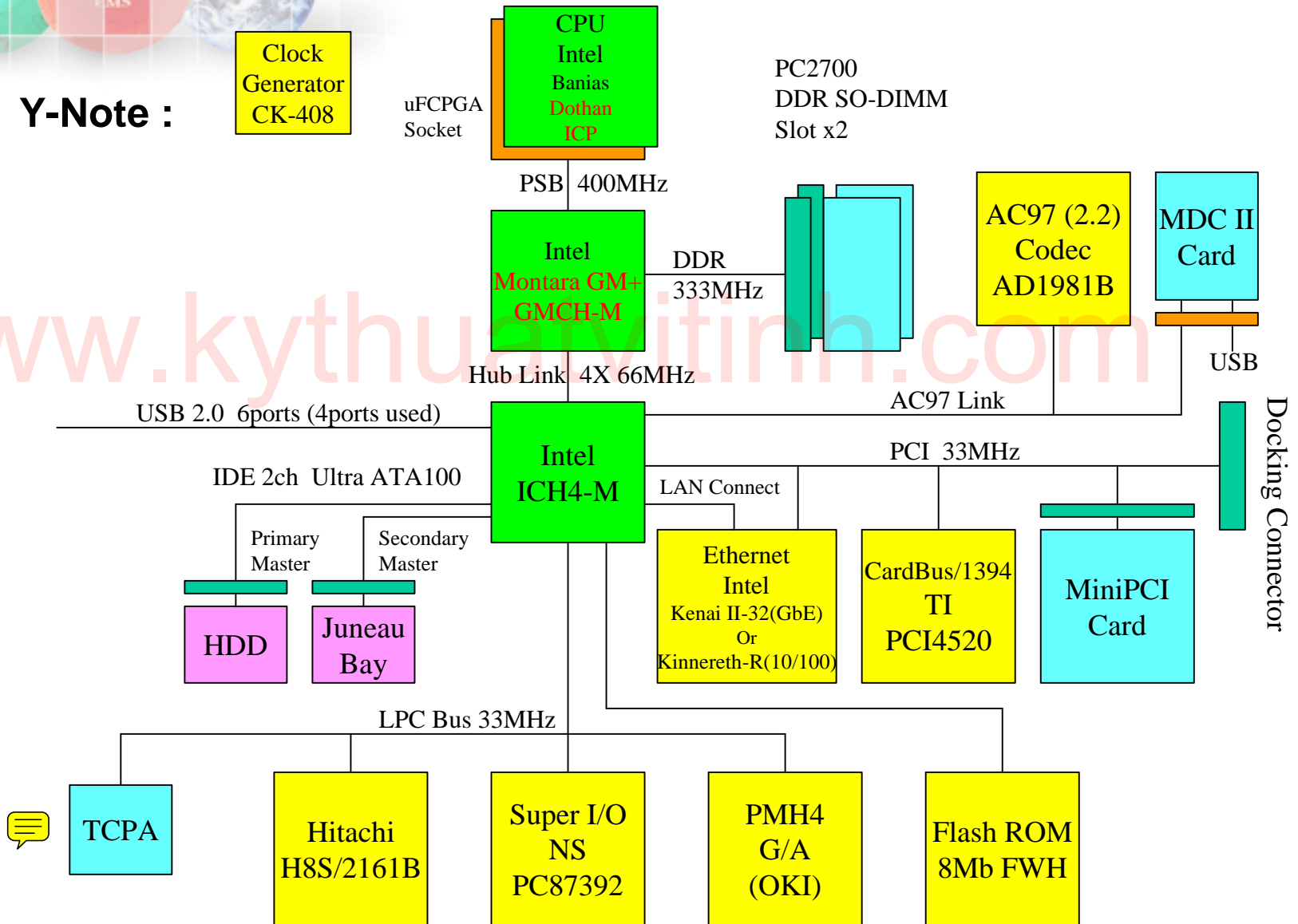

K-note Block diagram

K-Note :

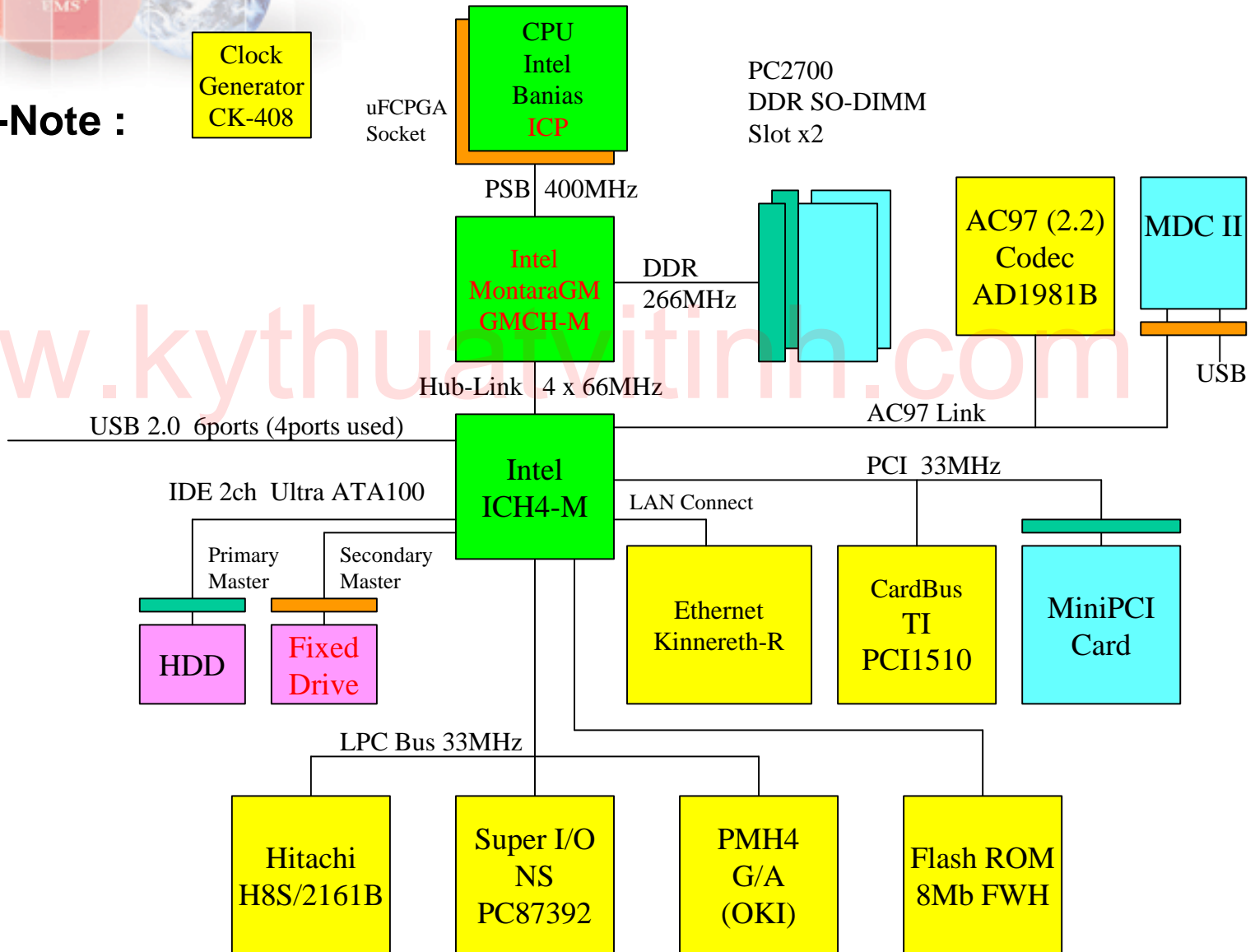



Checking sequence

Missing component, open, short → smell for burned →

DOCK-PWR16 (adapter in) → CV16 (adapter) → VINT16 (Q36) →

BAT-PWR12 (Q13) → VCC3SW →

VCC3M → VCC5M → VCC1R8M → VCC1R5M →

-SHUTDOWN2 → -PM_SLP_S3 → MPWRG → BPWRG → VCC5M_ON →

B_ON → VCC1R8M_ON → AUX_ON → VCORE_ON_PMH4 →

-VCC2R5A → VCC1R8B → VCC1R25B → VCC1R5B → VCC3B →

→ VCCCPUCORE → CPUVIO → VCC5B → VCCVIDEOCORE →

→ CLOCKS → -PCIRST...

Can't Power on with Adapter(1/2)

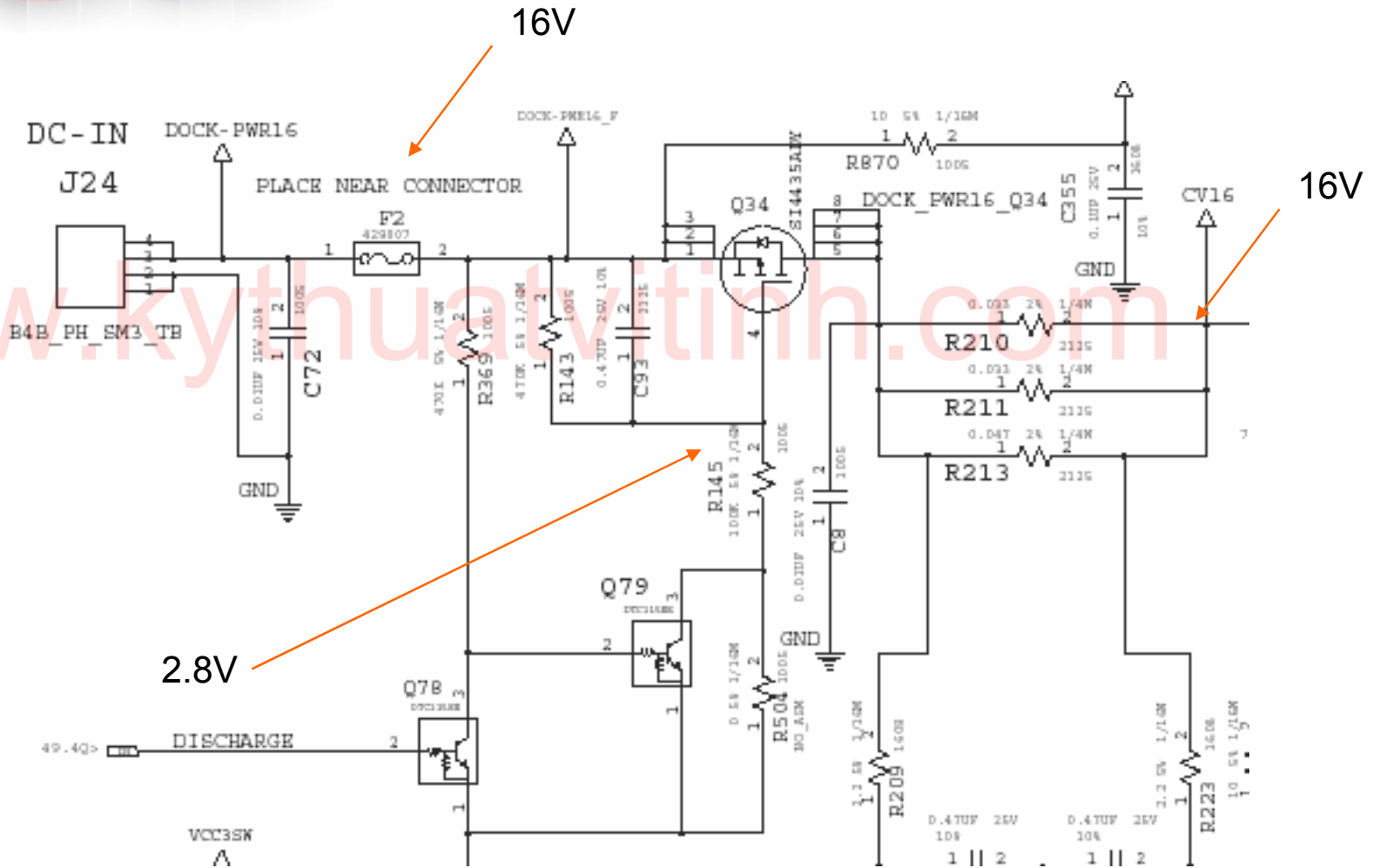

- Check missing component, open, short

Can't Power on with Adapter(2/2)

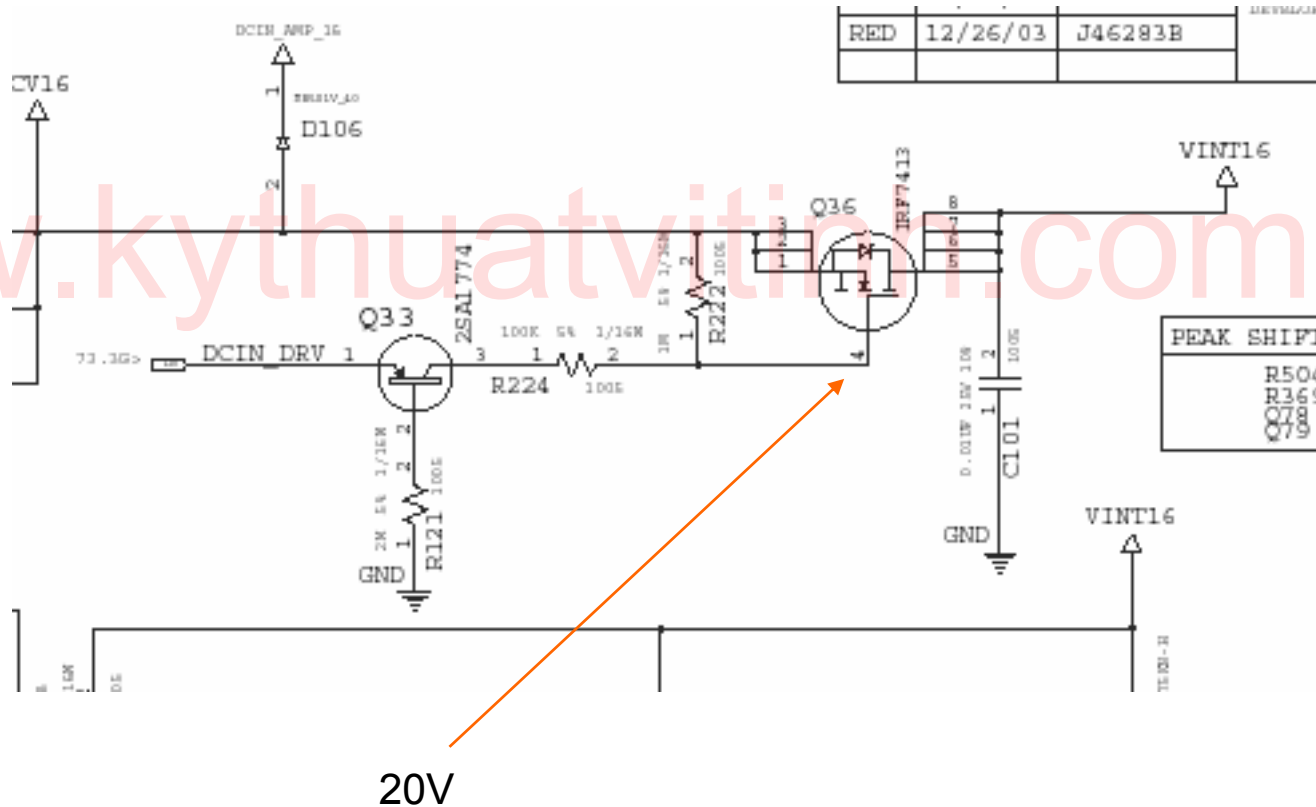

- Check missing component, open, short

Can't Power on with Battery

- Check missing component, open, short

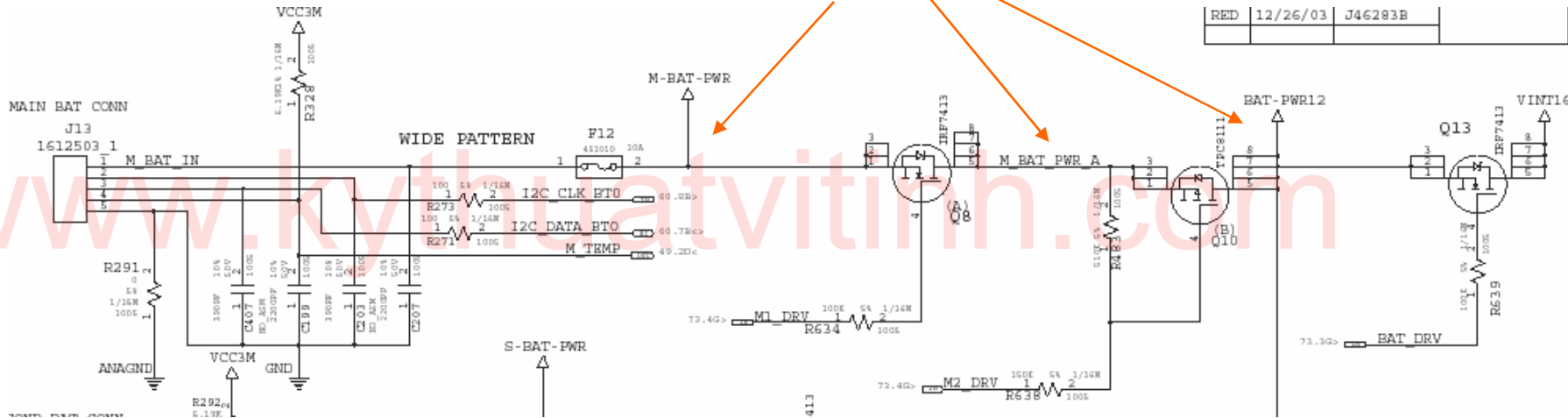

- And also for corresponding 2nd battery

Can't Charge Battery(1/3)

▪ Check missing component, open, short

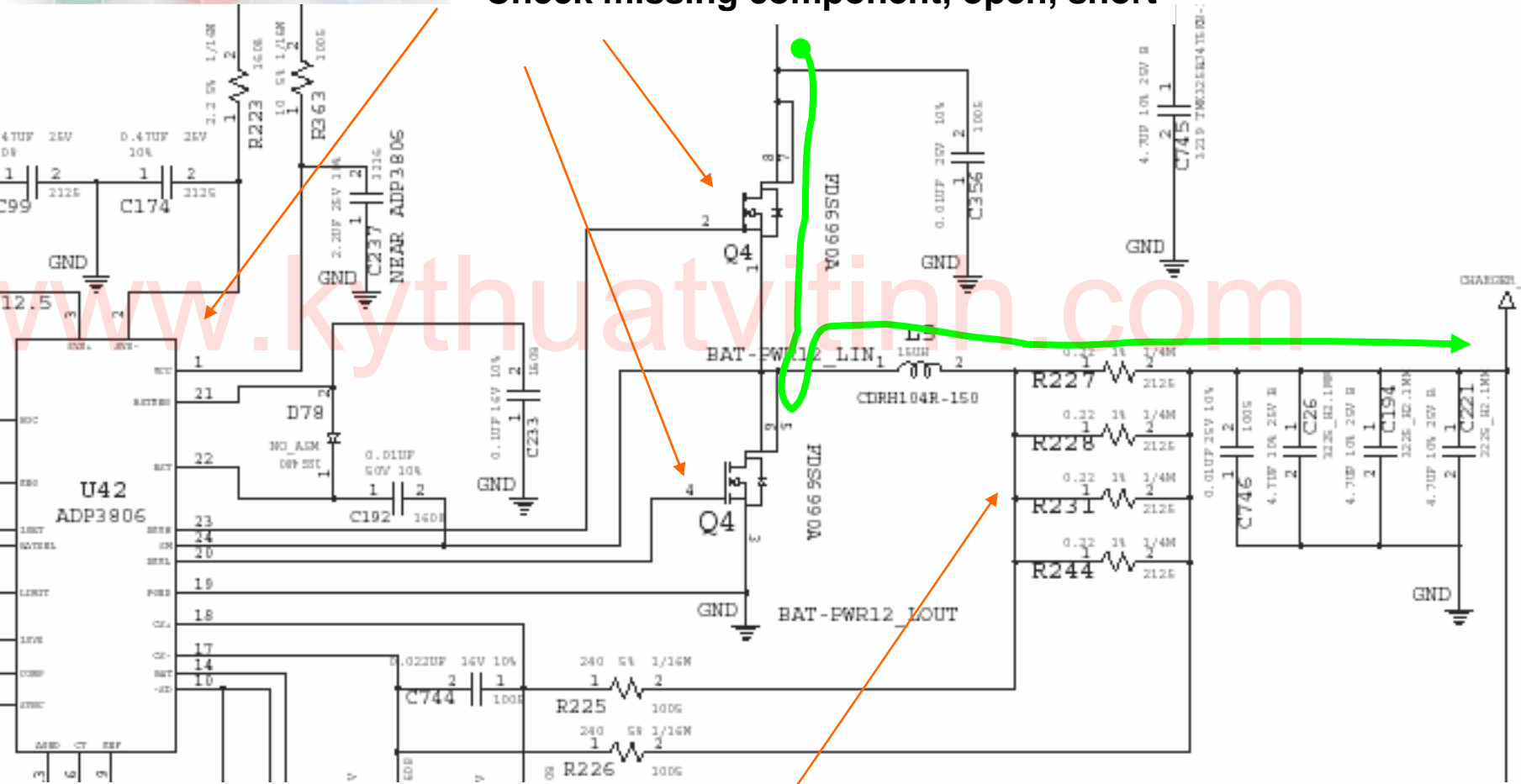

Can't Charge Battery(2/3)

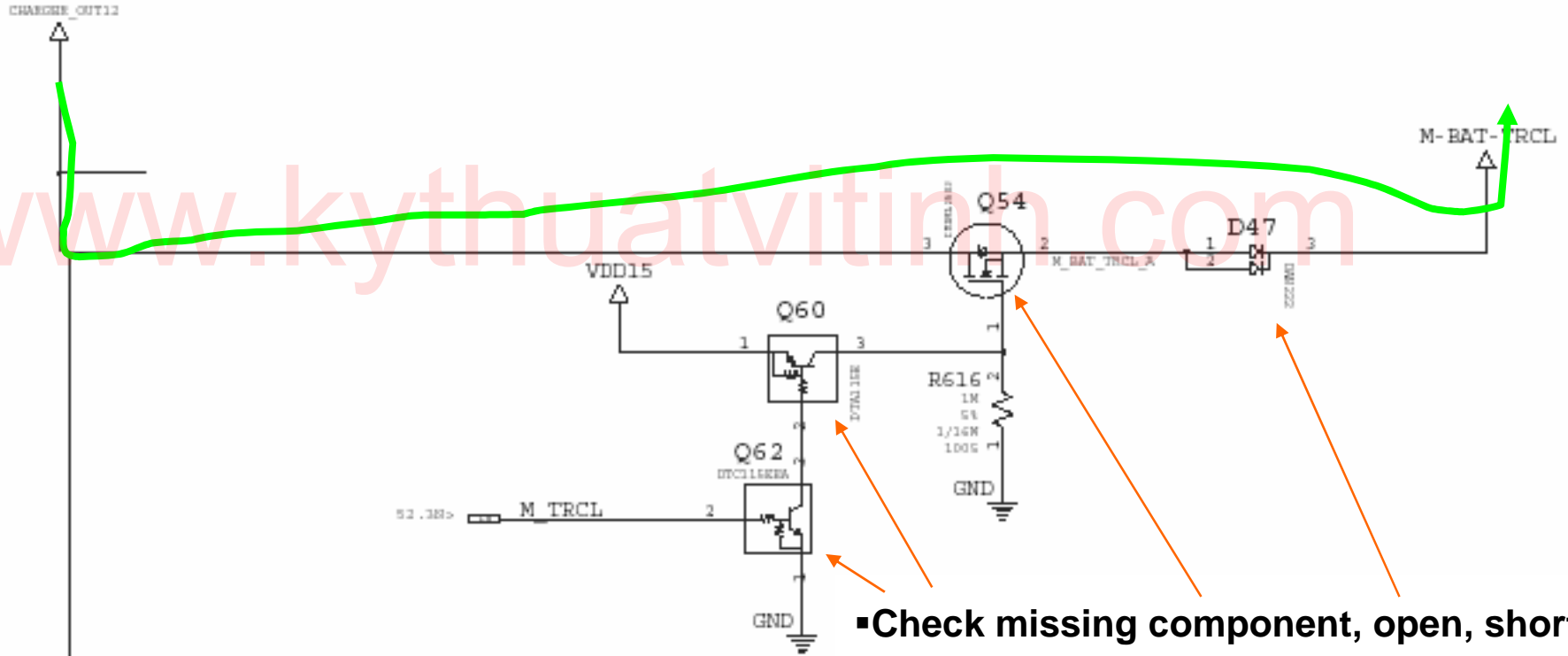

Check missing component, open, short

Can't Charge Battery(3/3)

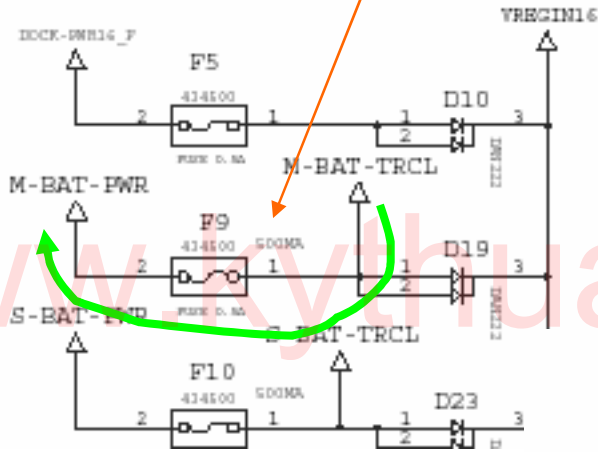

- Check missing component, open, short
- Check net "I2C_CLK_BT0", "I2C_DATA_BT0"

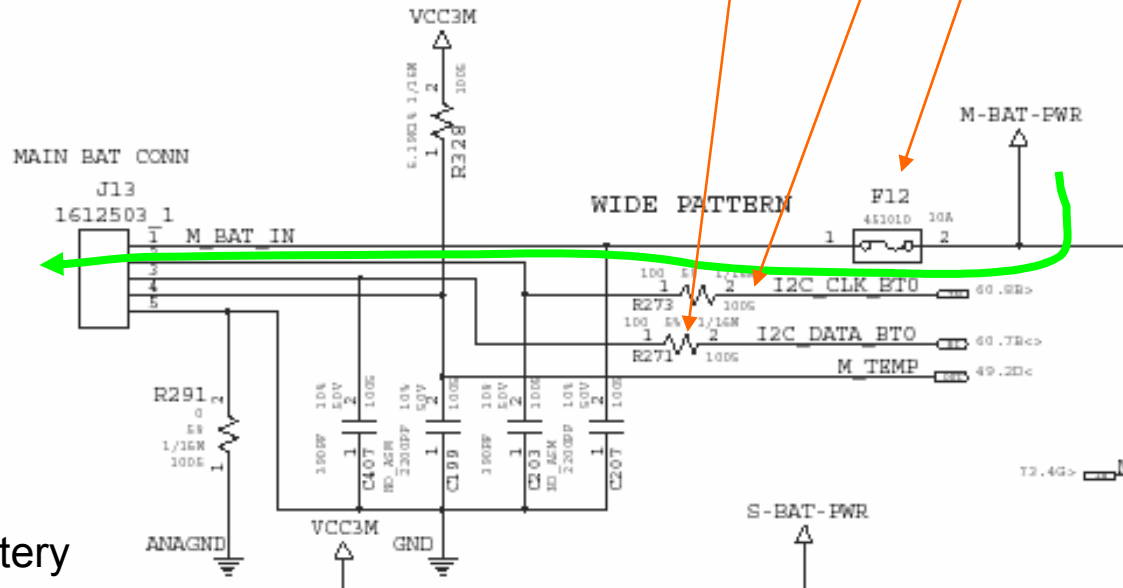

- And also for corresponding 2nd battery

Power-VCC5M

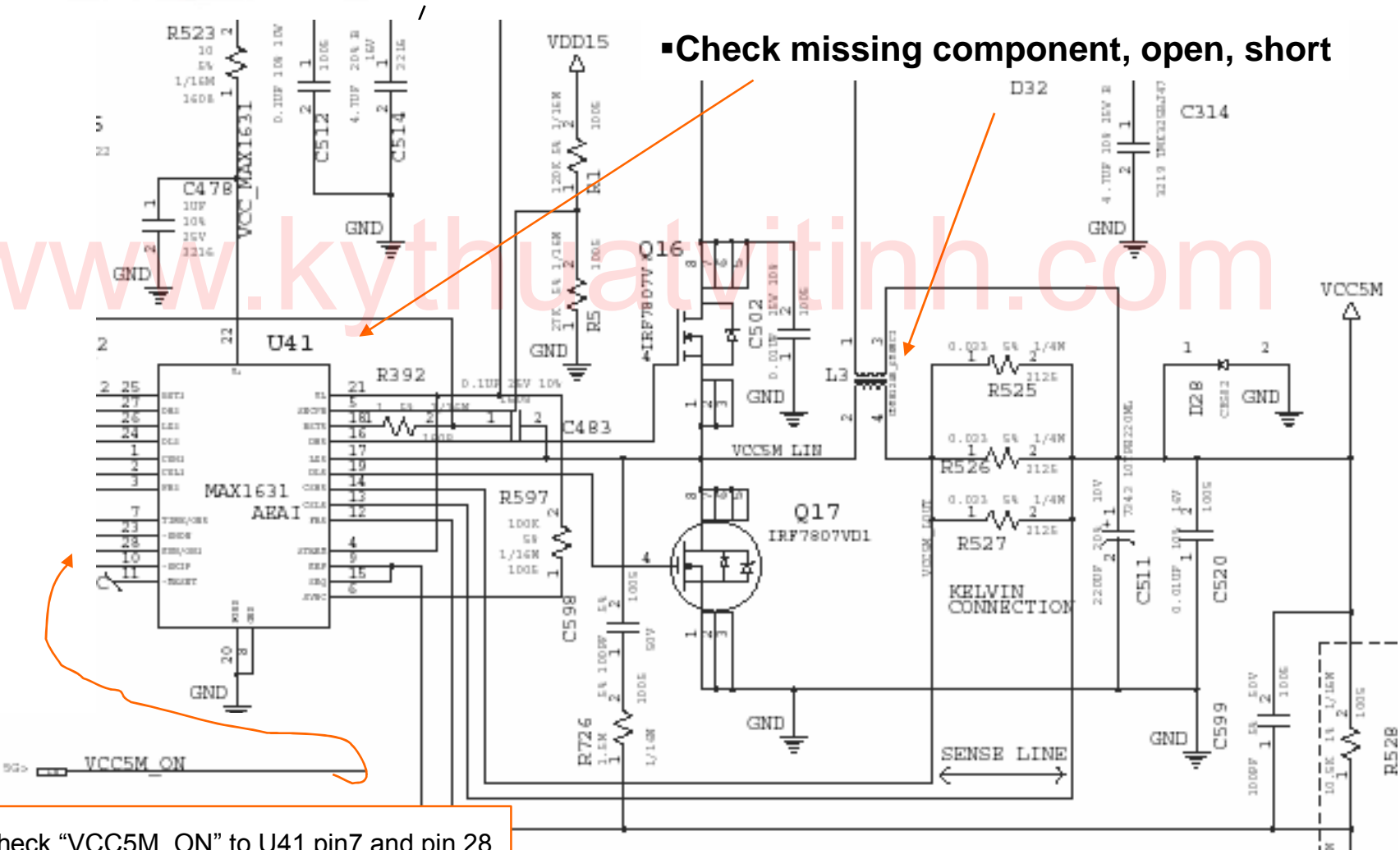

Power-VCC5B / VCC5MUMBAY

- Check missing component, open, short

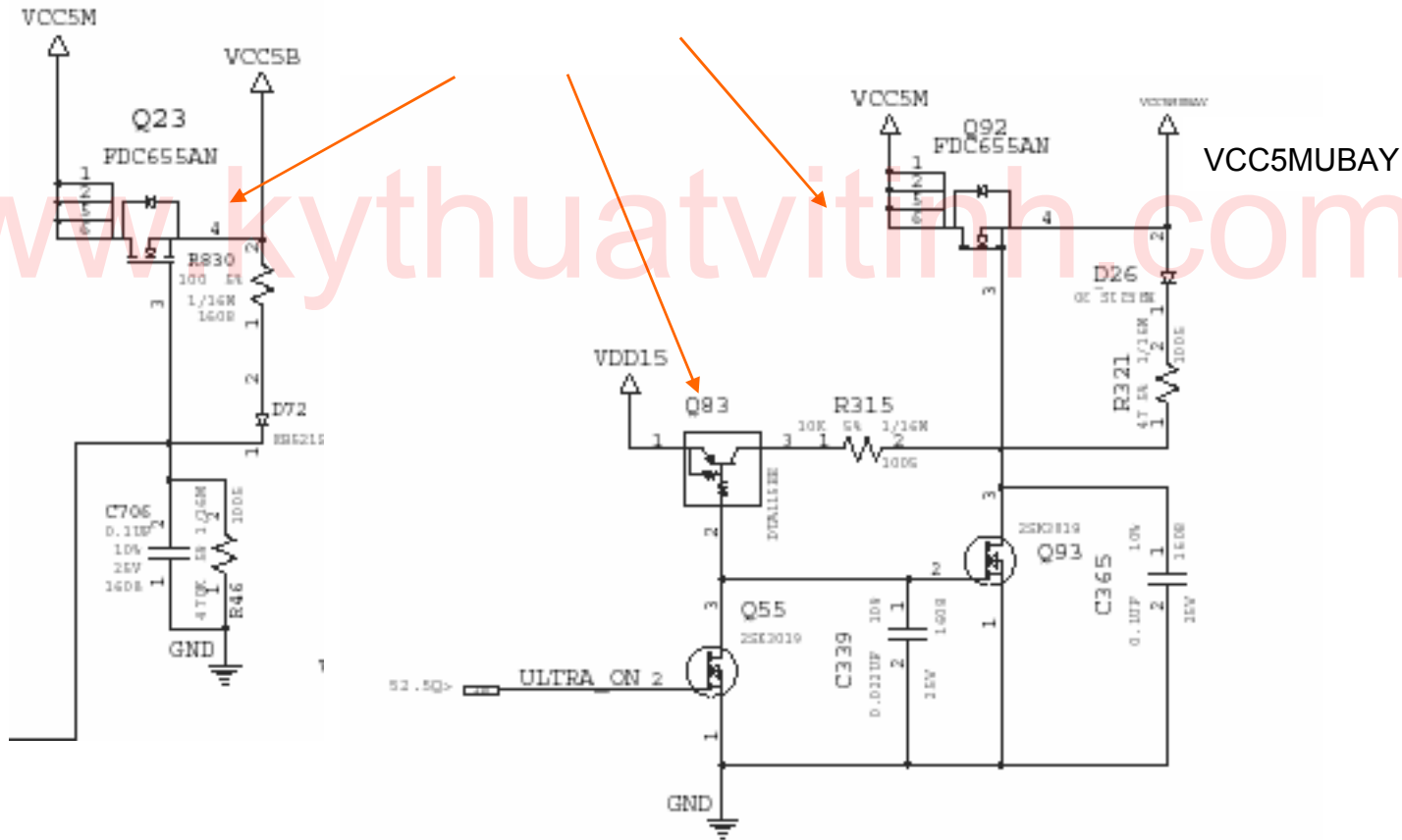

Power-VCC5B / VCC3A / VCC3B

▪ Check missing component, open, short

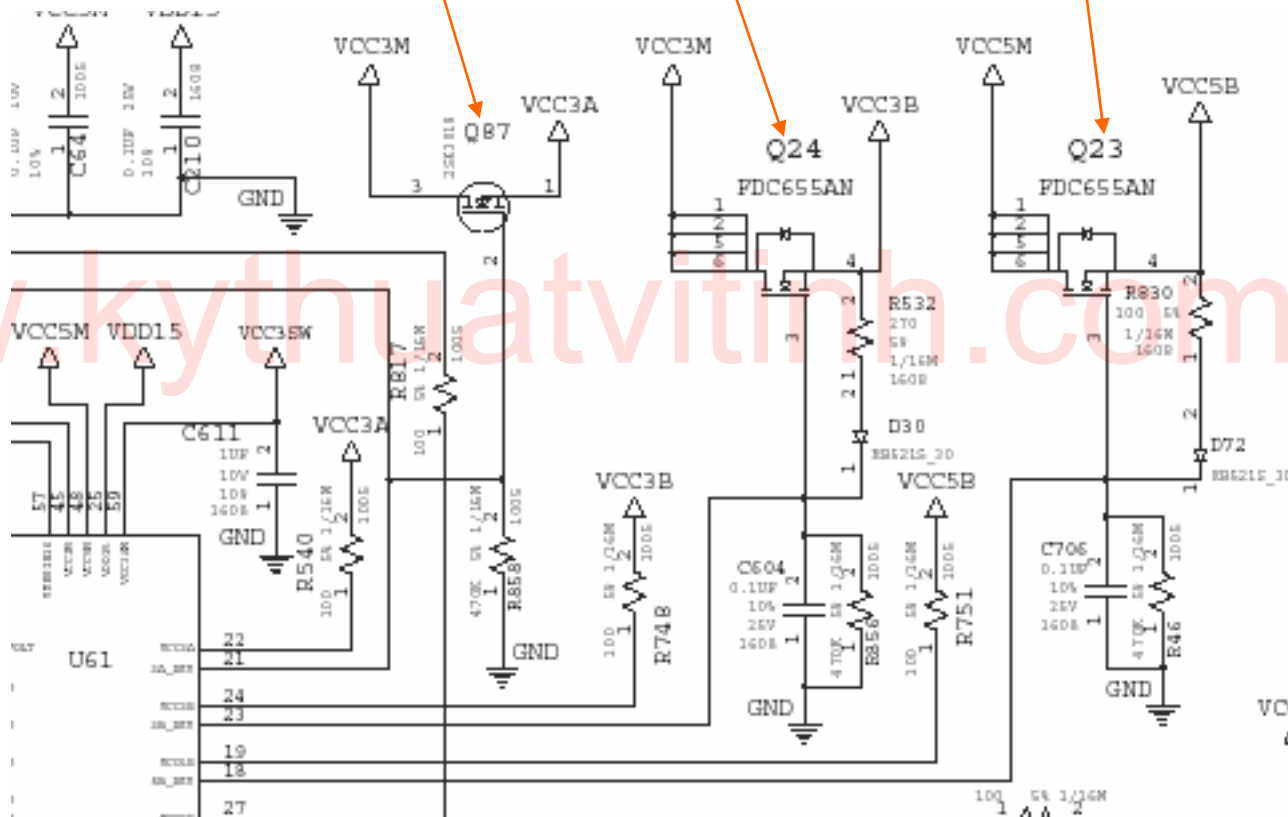

Power-VCC3M

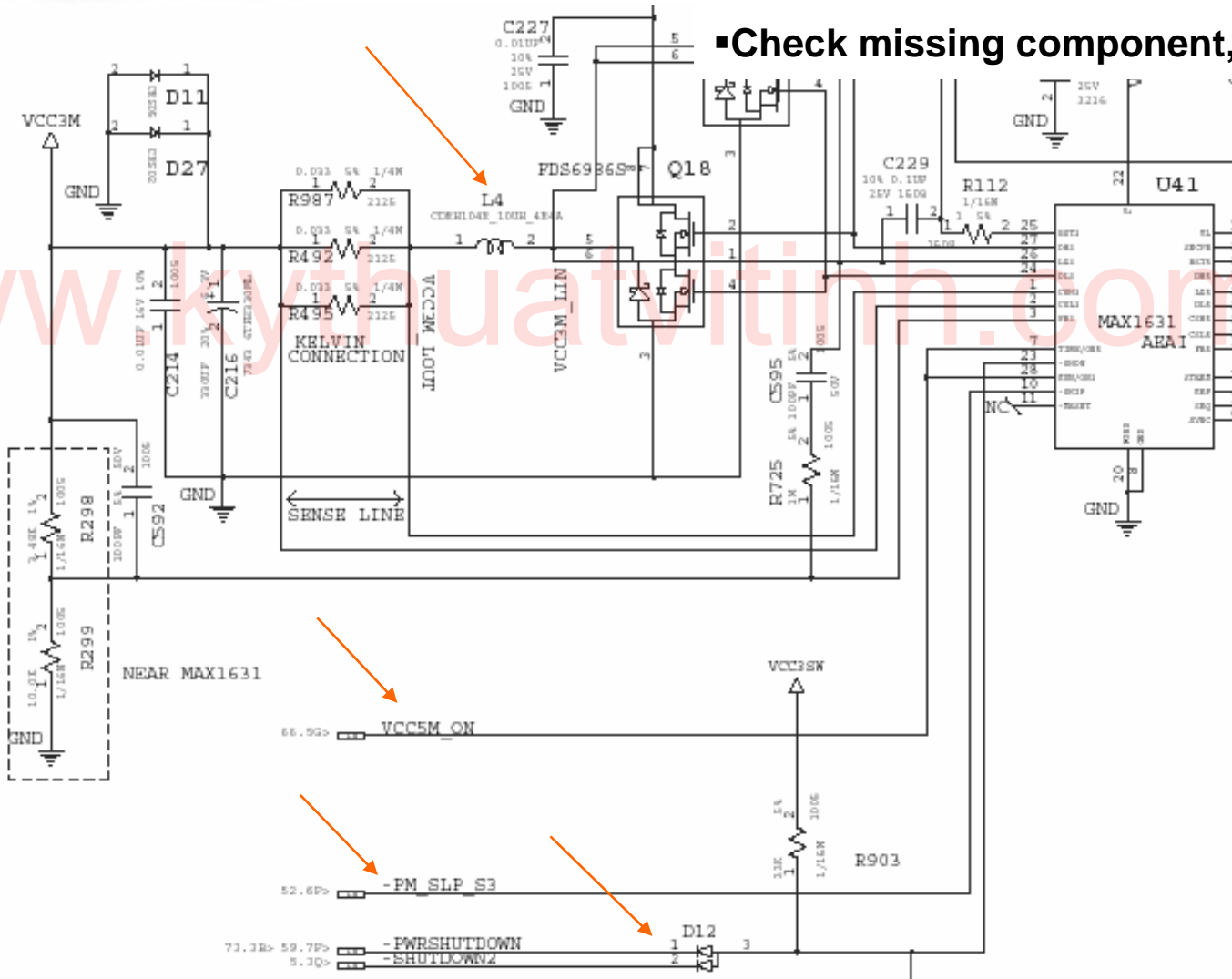

■ Check missing component, open, short

Power-VCC3AUX / VCC3_V

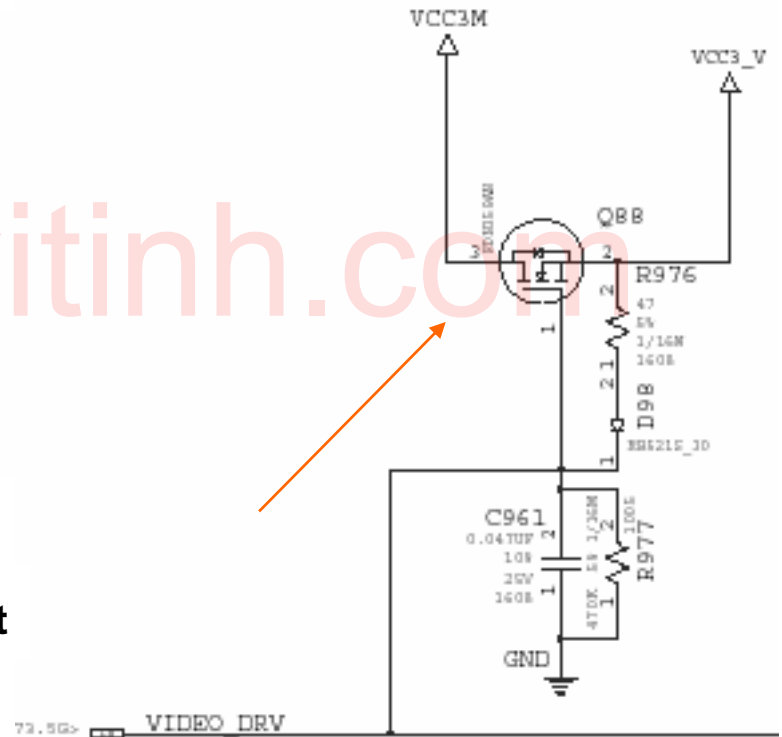
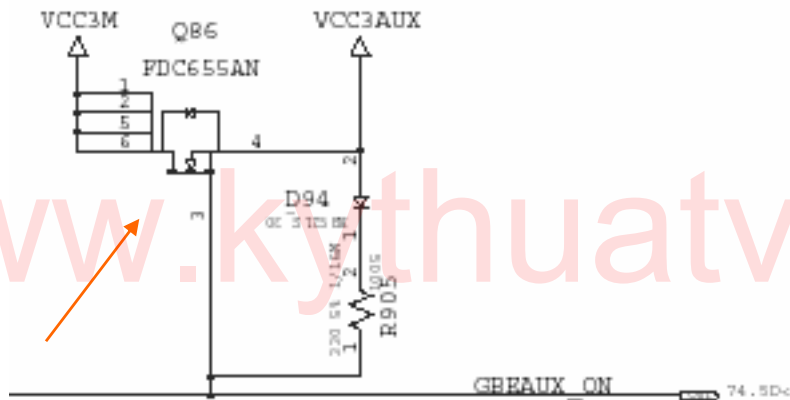

▪ Check missing component, open, short

Power-VCC1R2M

- Check missing component, open, short

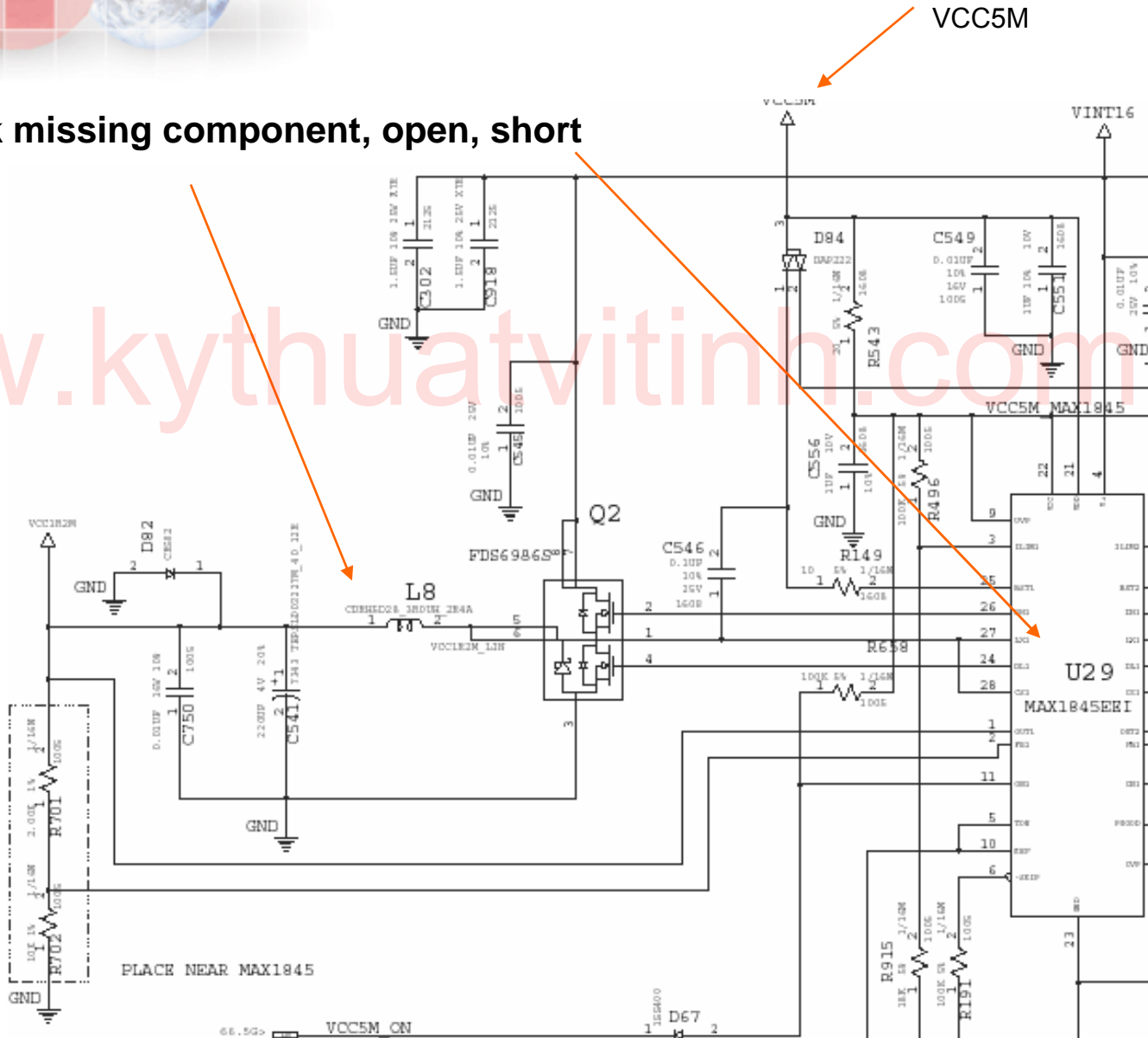

Power-VCC1R2B

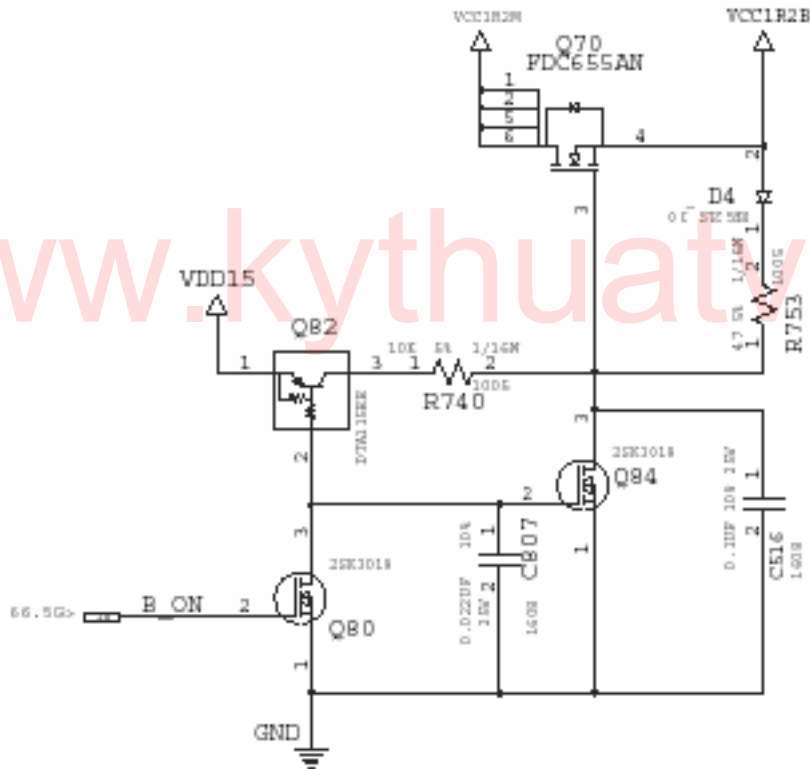

- Check missing component, open, short

Power-VCC1R25B

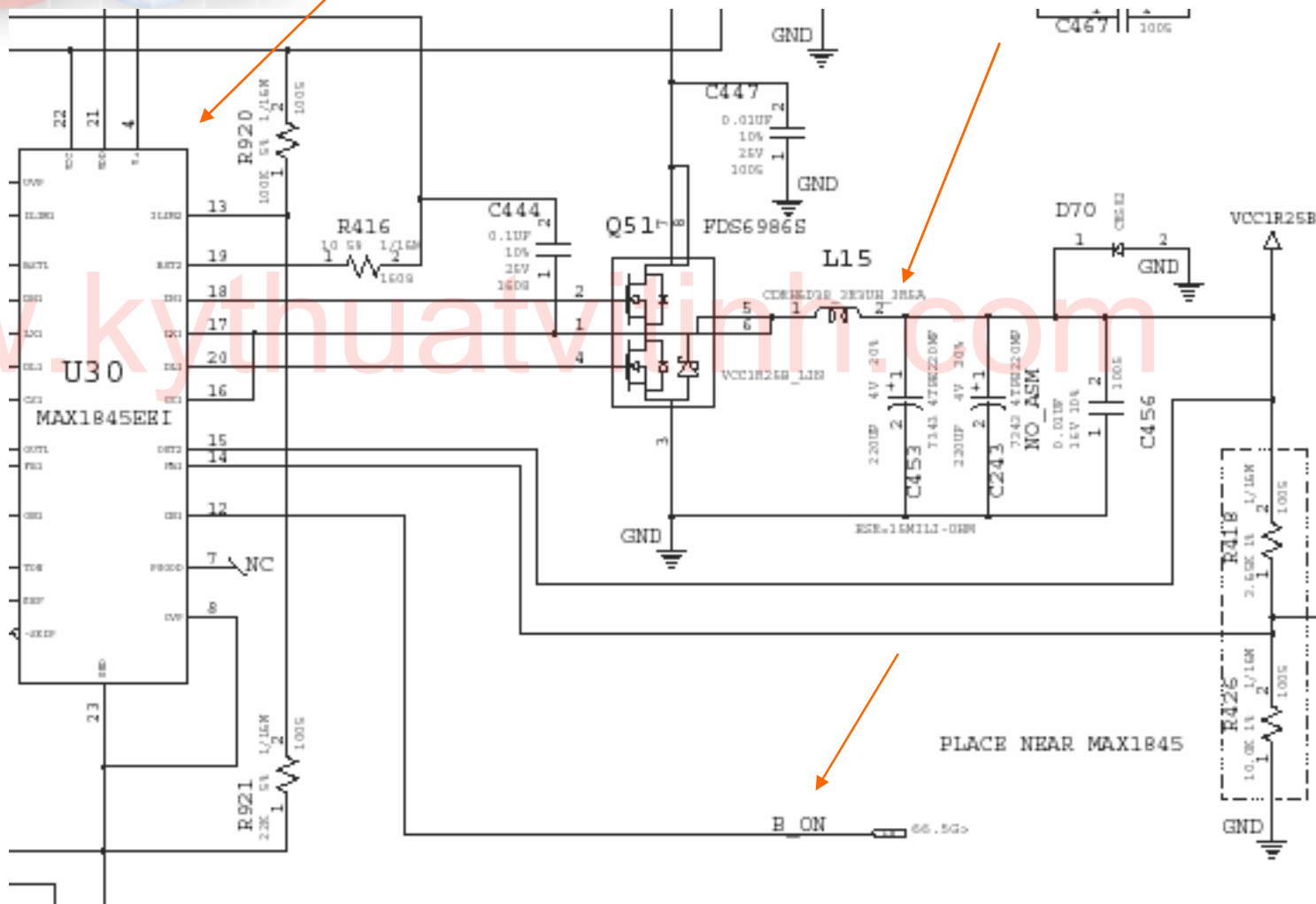

- Check missing component, open, short

Power-VCC2.5_V / VCC1.8_V

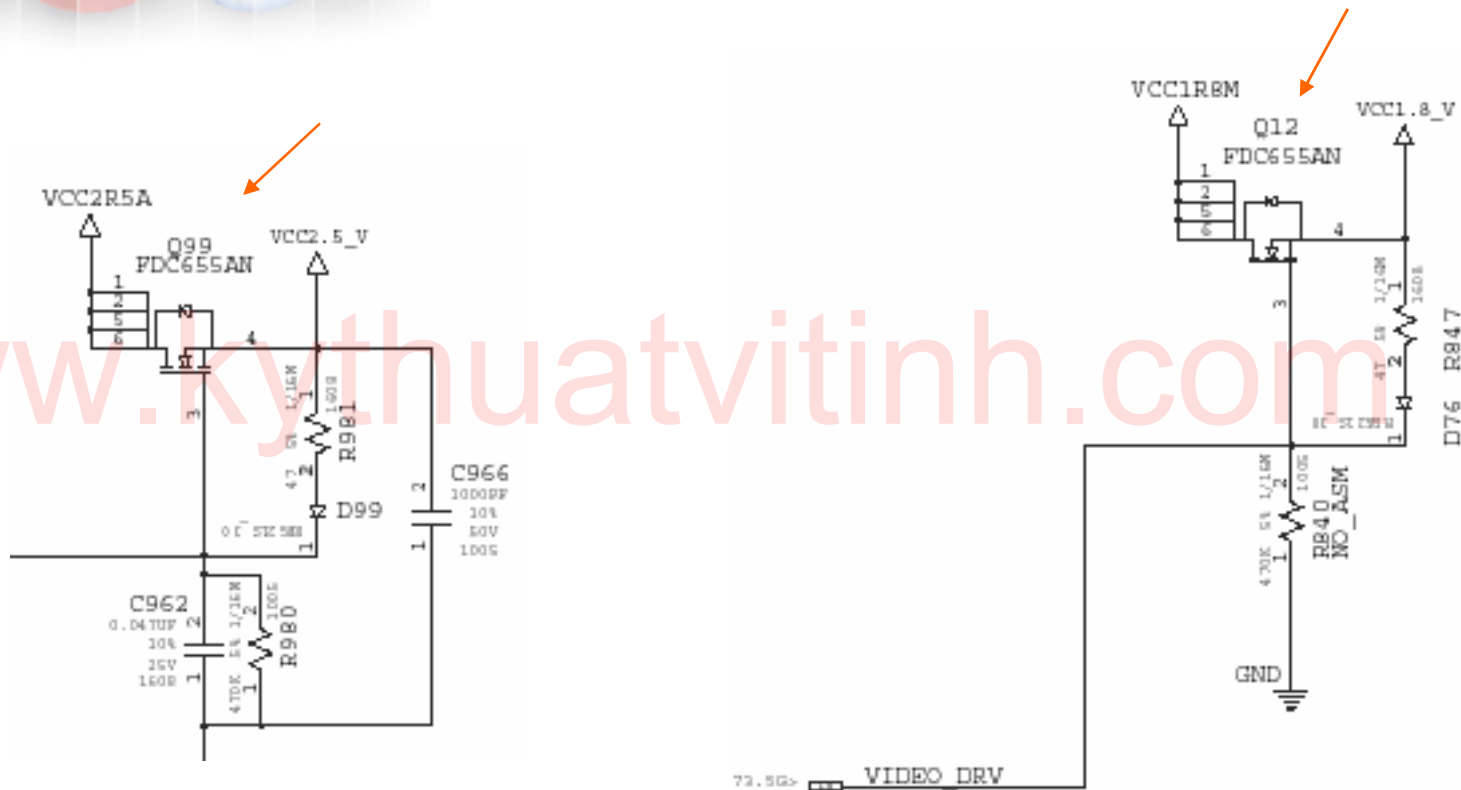

- Check missing component, open, short

Power-VCCVIDEOCORE

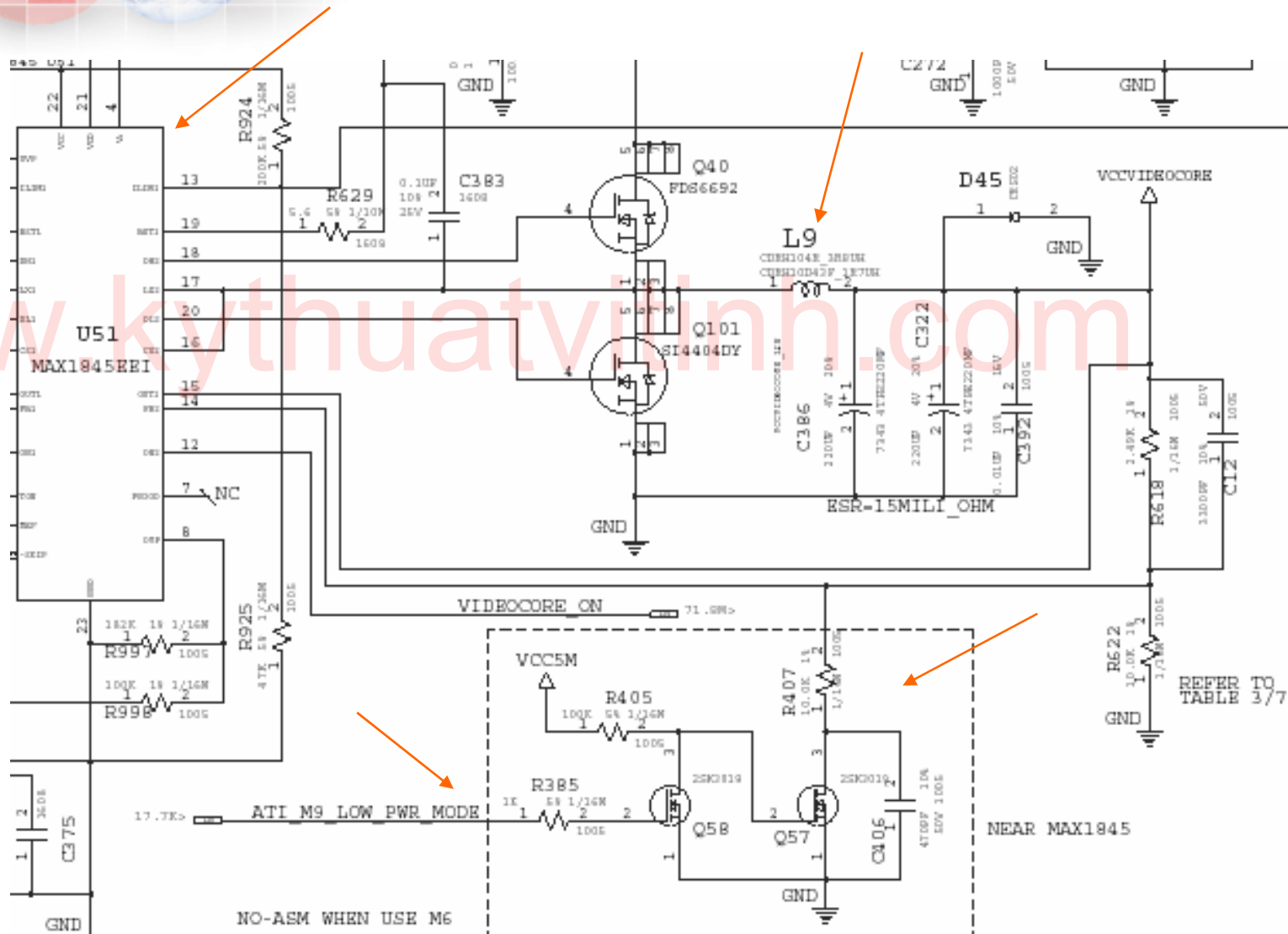

Check missing component, open, short



Power-VCCPCUCORE(1/2)

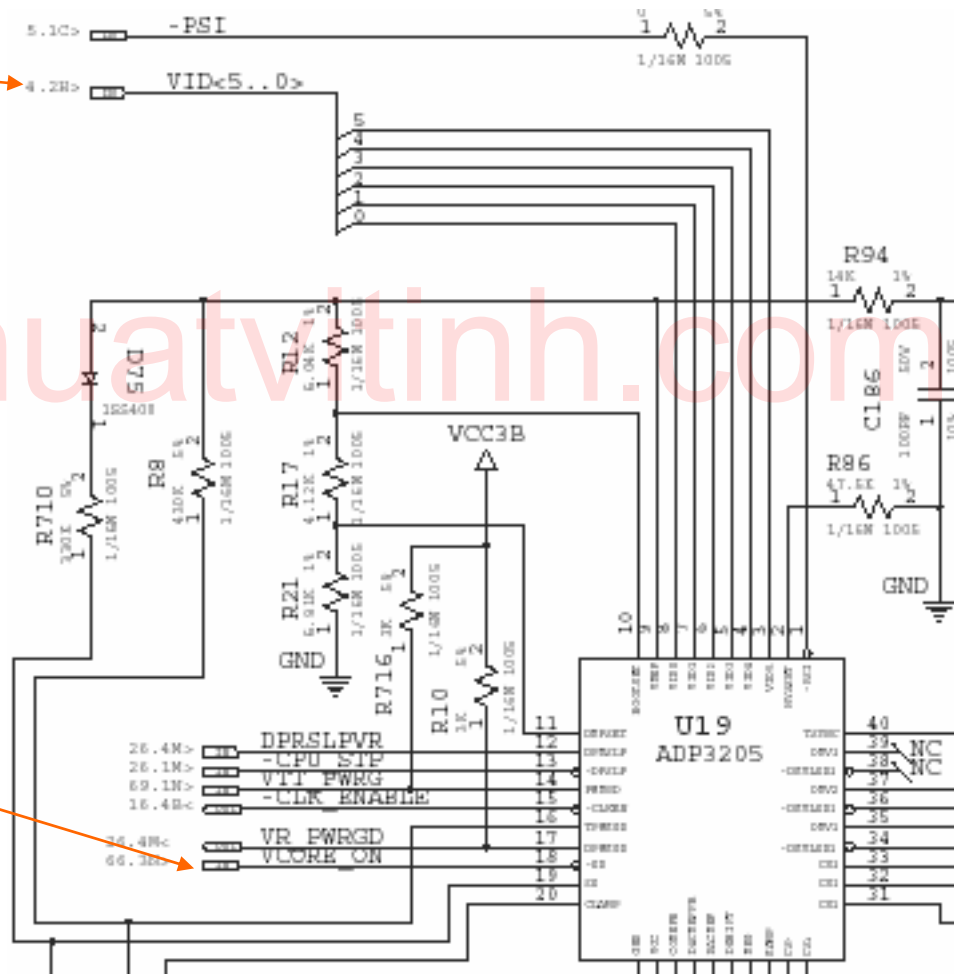

www.kythuathinh.com

Power-VCCCPUCORE(2/2)

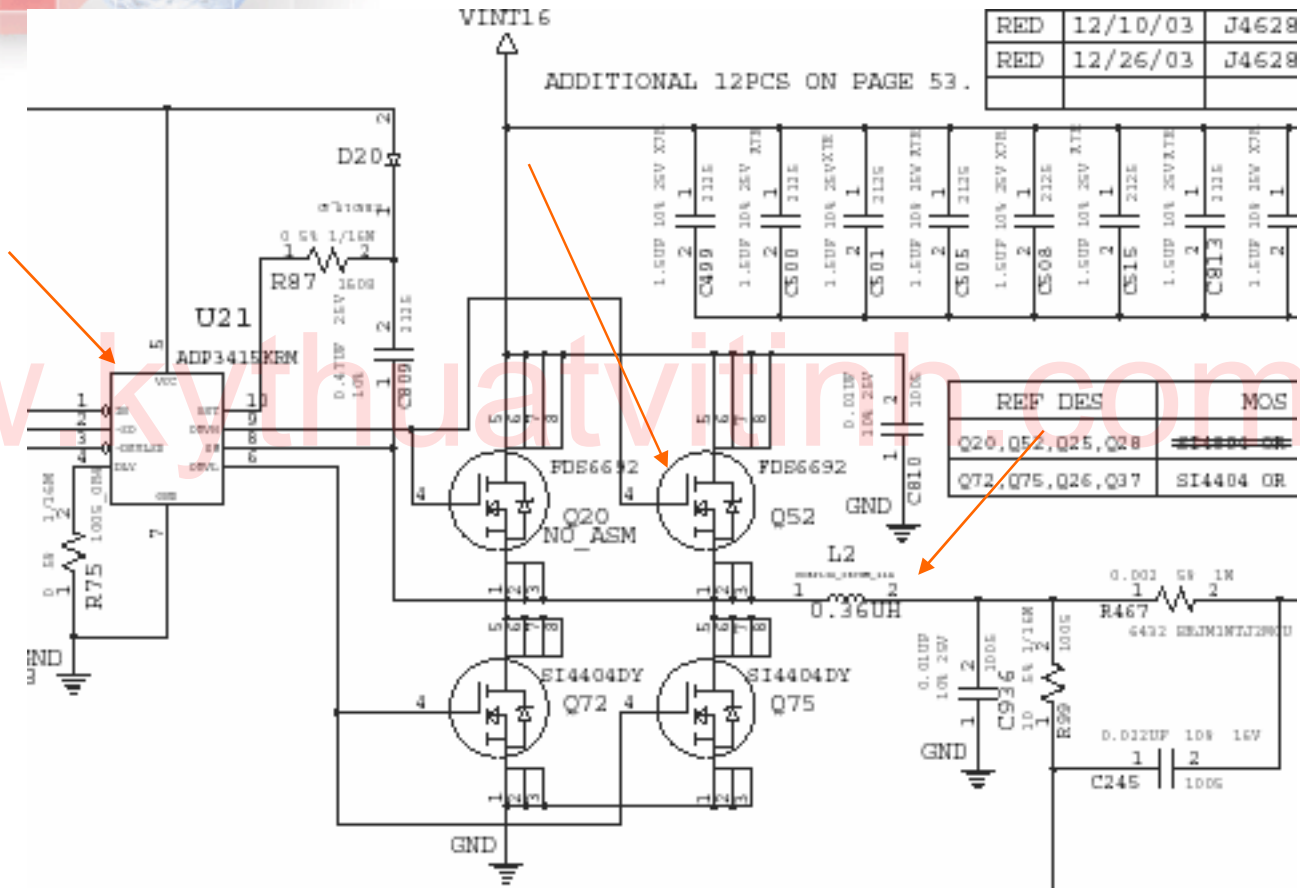

- Check missing component, open, short
- And also check: U25, Q25, Q26, Q28, Q37, L7



No Work :Not boot propriety (1/3)

■ Checking:

KEY compoment:insert propriety?

visual checking:soldering/missing compoment

Colock:signal quality is OK?

Power:correct voltage?

No Work : Not boot propriety (2/3)

AP FOR EACH VDD PINS

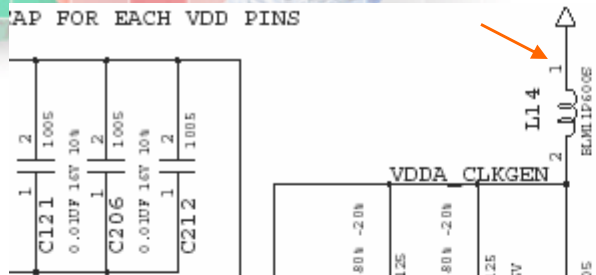

Clocks

DATE	DESCRIPTION	DEVELOPMENT NO.	Q/M
6/03	J46283B		16

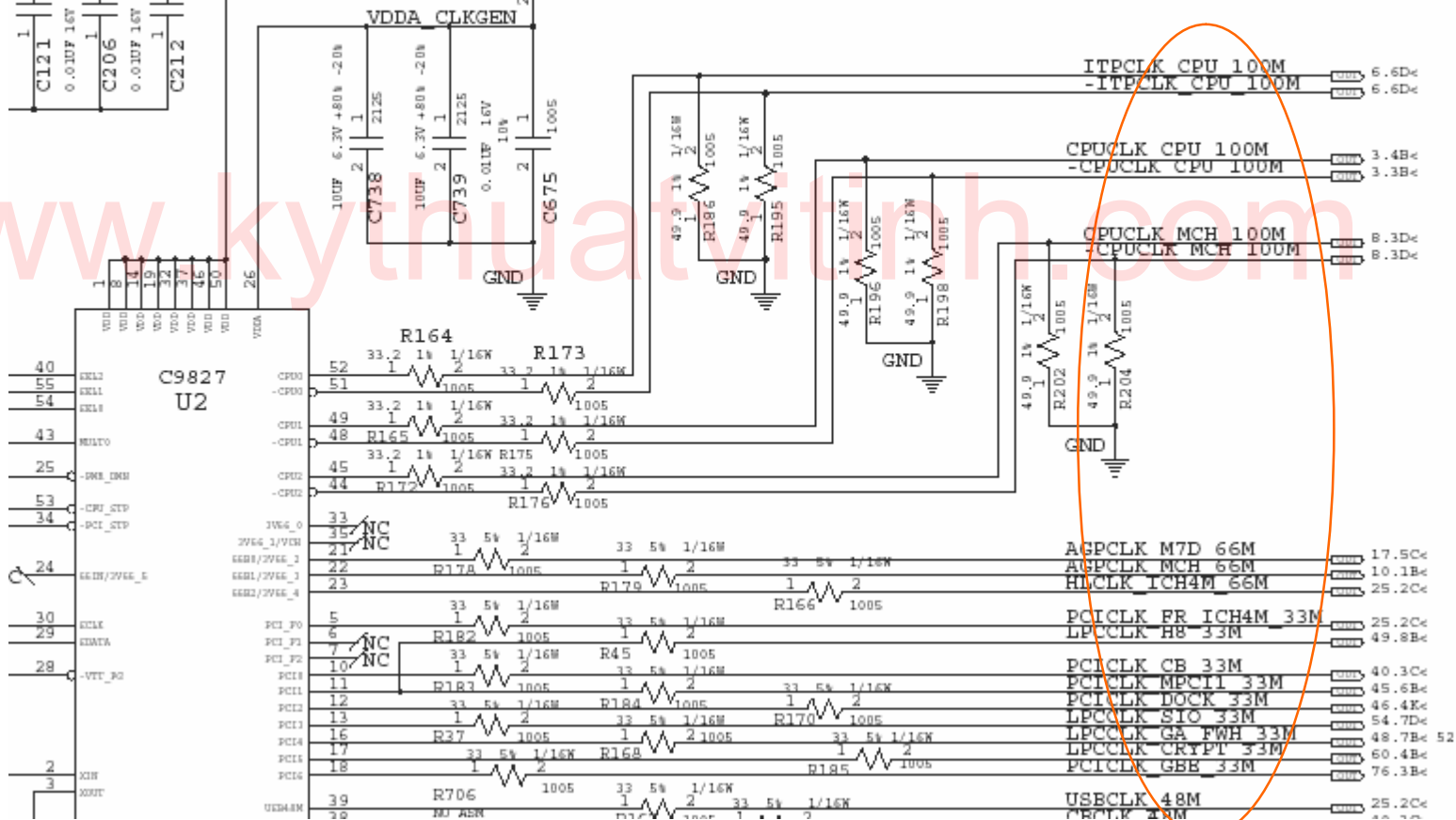



No Work :Not boot propriety (3/3)

- Critical Signals

- MPWRG:D83,pin2

- -PCIRST:R193

- CPUPWRGD:(SB to CPU)

- -CPURST:(NB to CPU)



No Work : LEDs

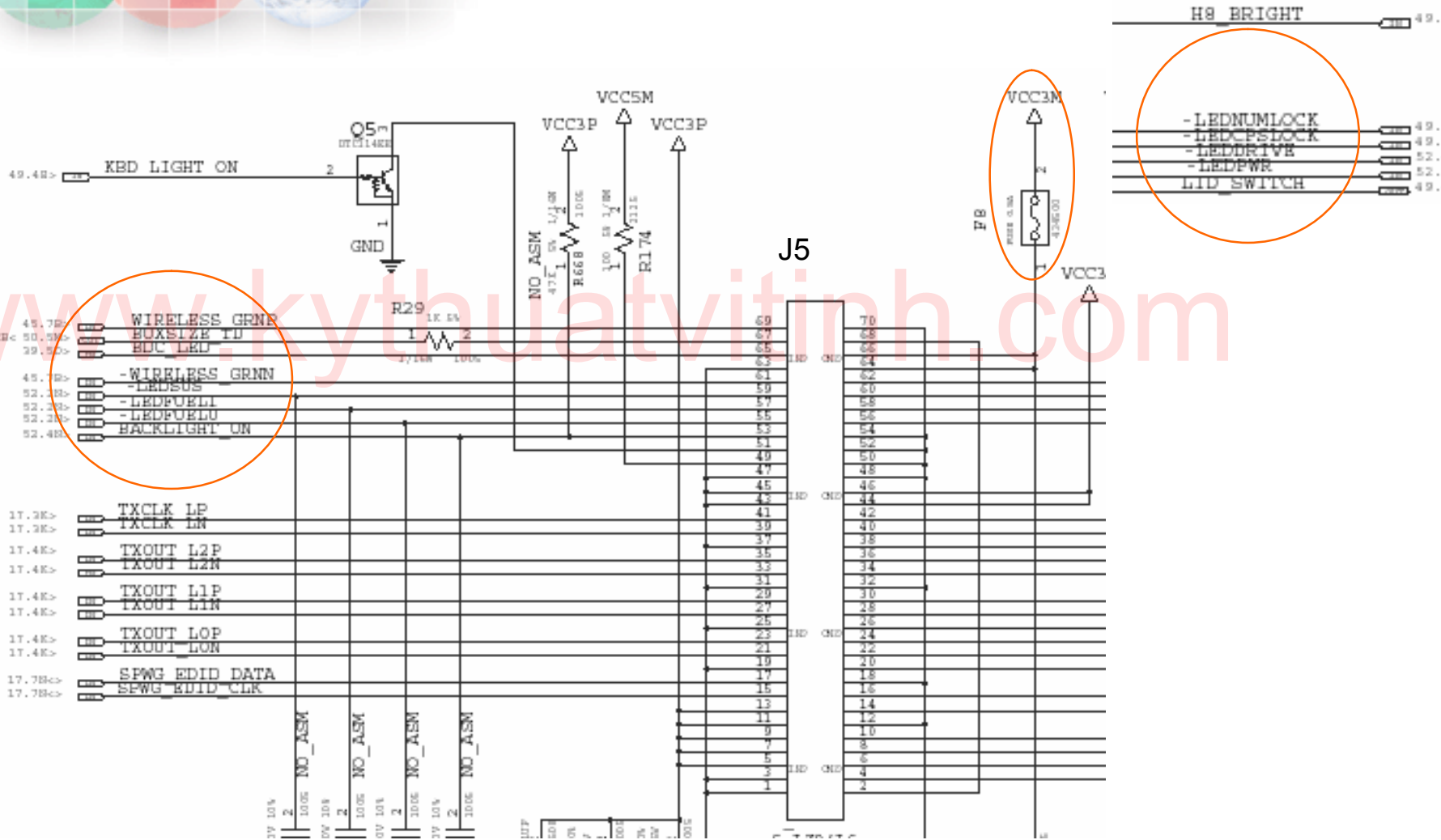

No Work : Back light

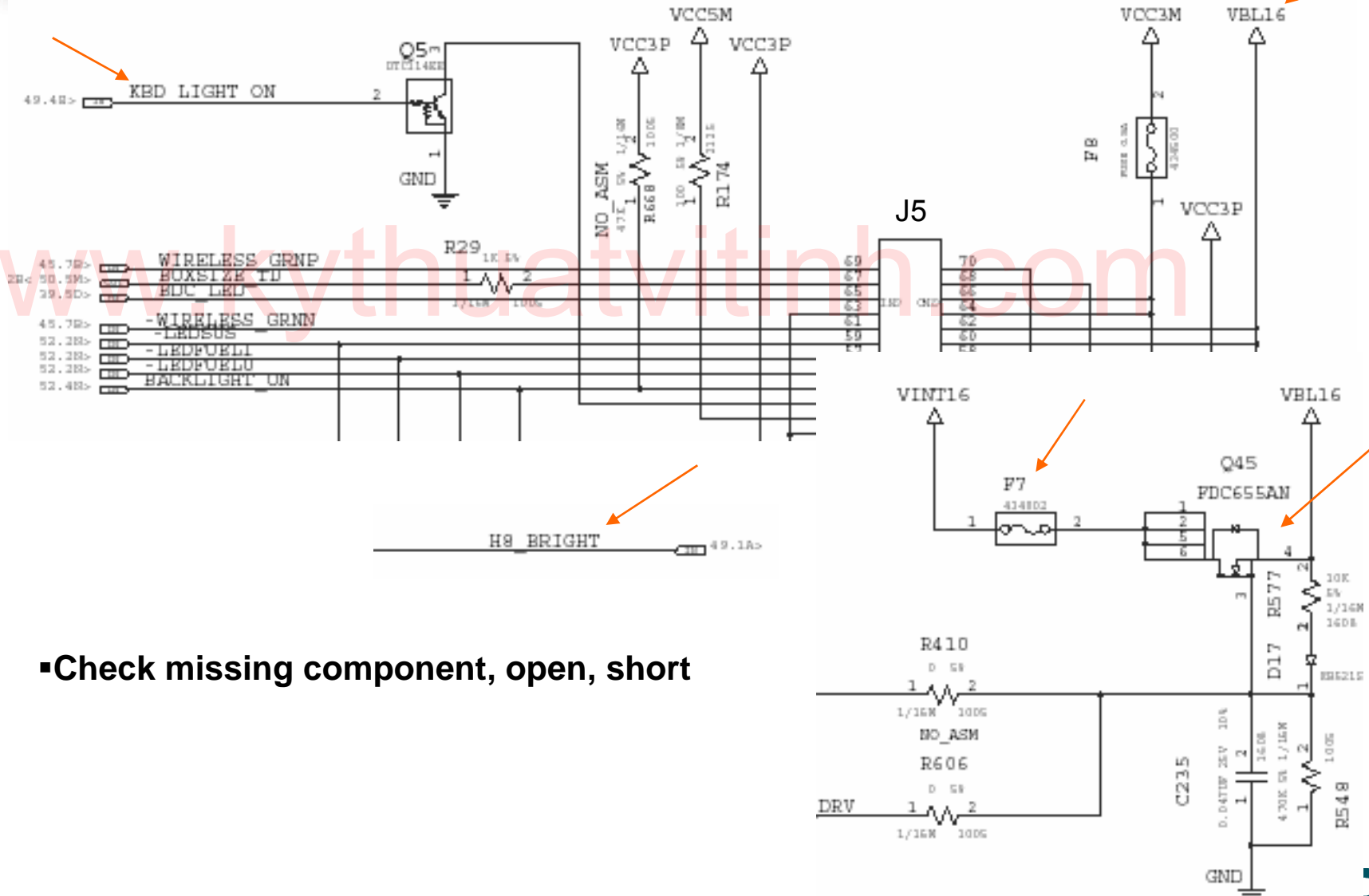

▪ Check missing component, open, short



No Work : LCD

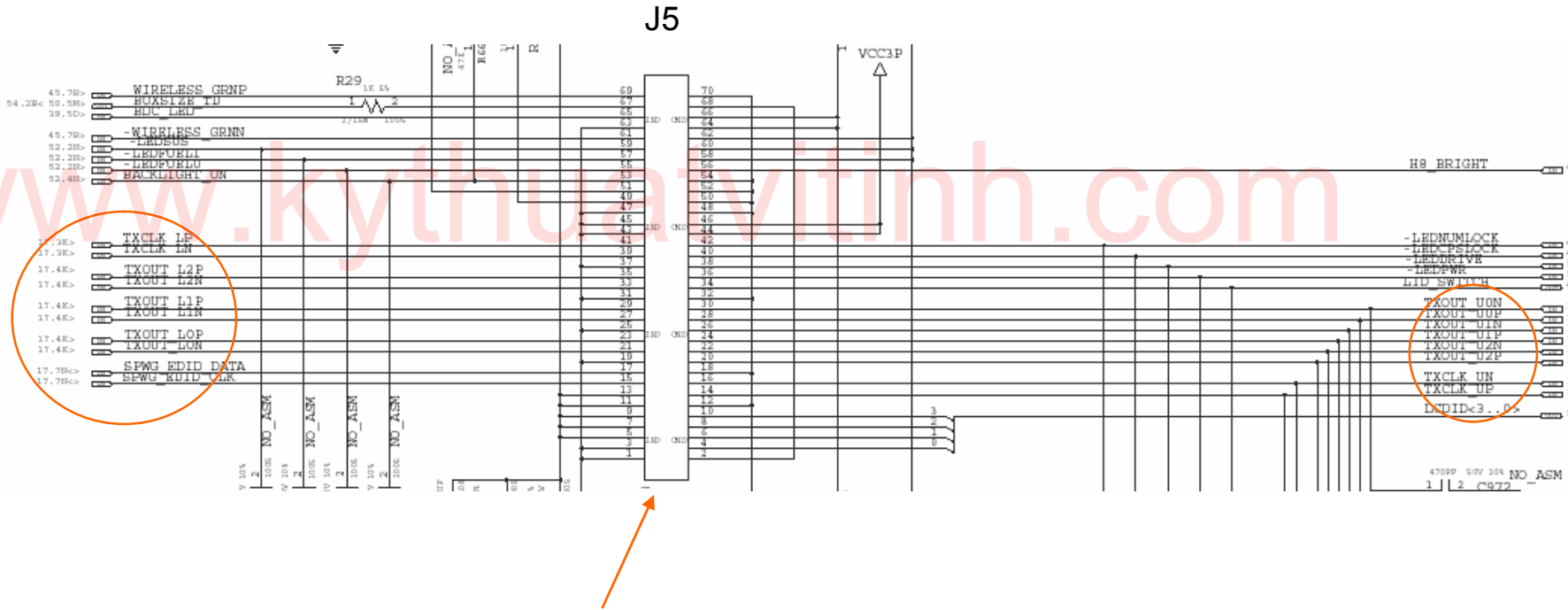

▪Check soldering,missing component, open, short

No Work : CRT (1/2)-R/G/B

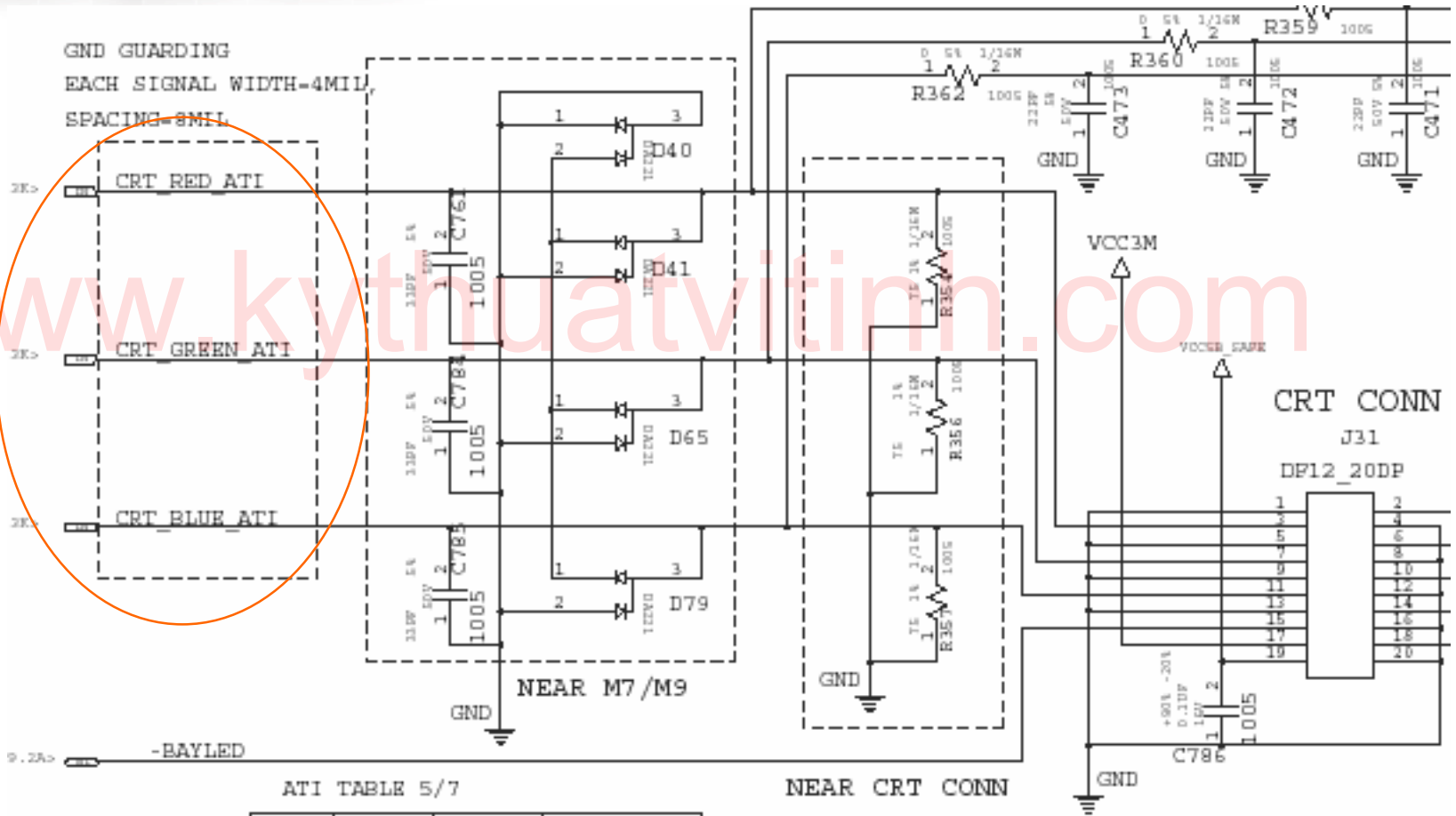

- Check missing component, open, short



No Work : CRT (2/2)-H/V

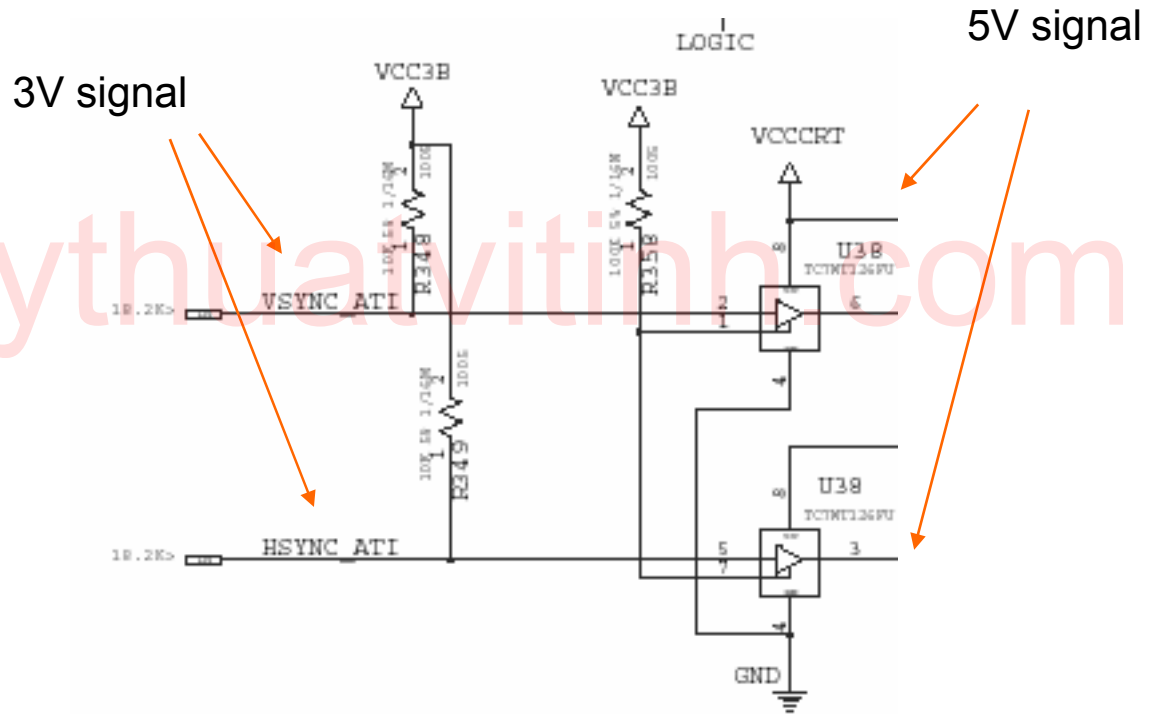

- Check missing component, open, short

No Work : TV

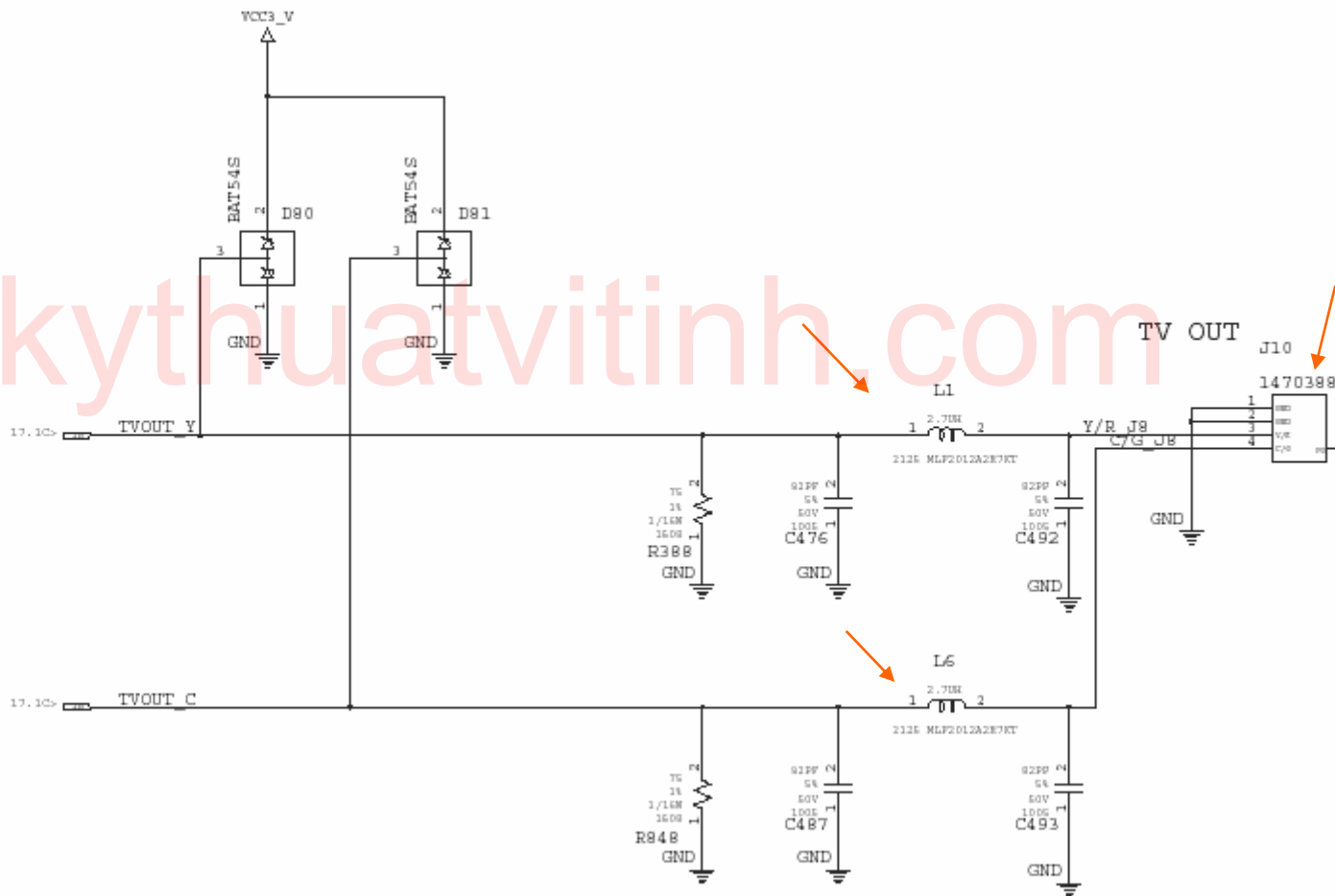

- Check solder, missing component, open, short

No Work : Audio (1/4) –AC97

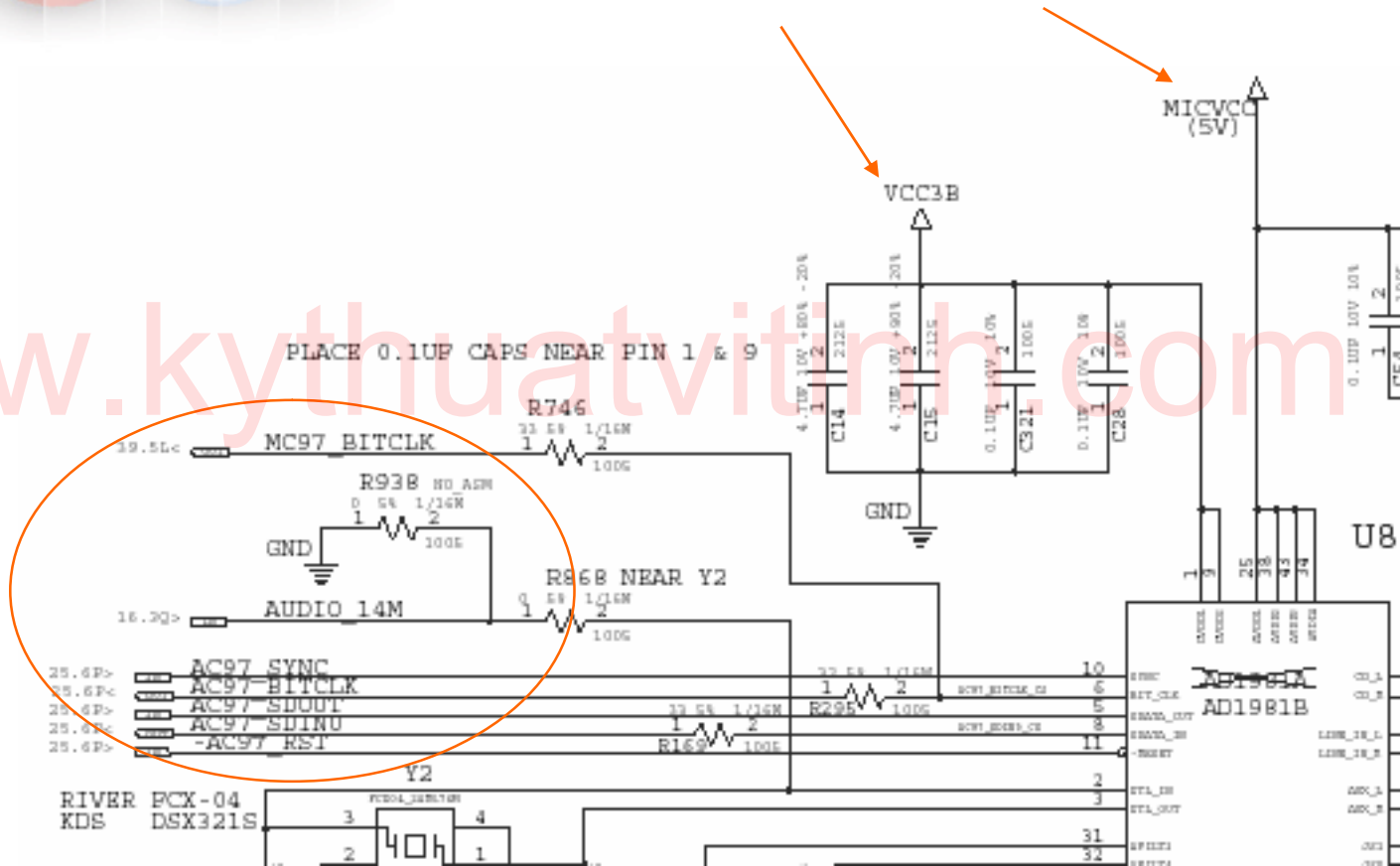

- Check missing component, open, short

No Work : Audio (2/4) – Input and Output

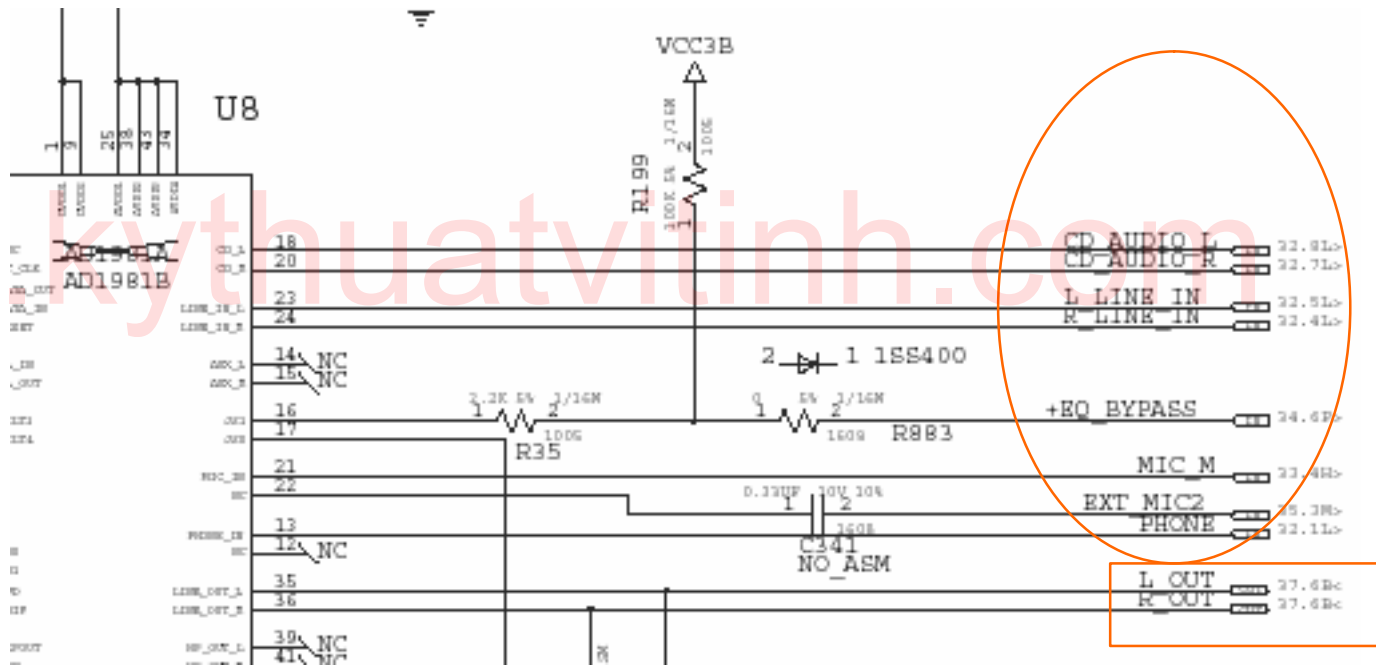

- Check missing component, open, short

No Work : Audio (3/4) – Input and Output

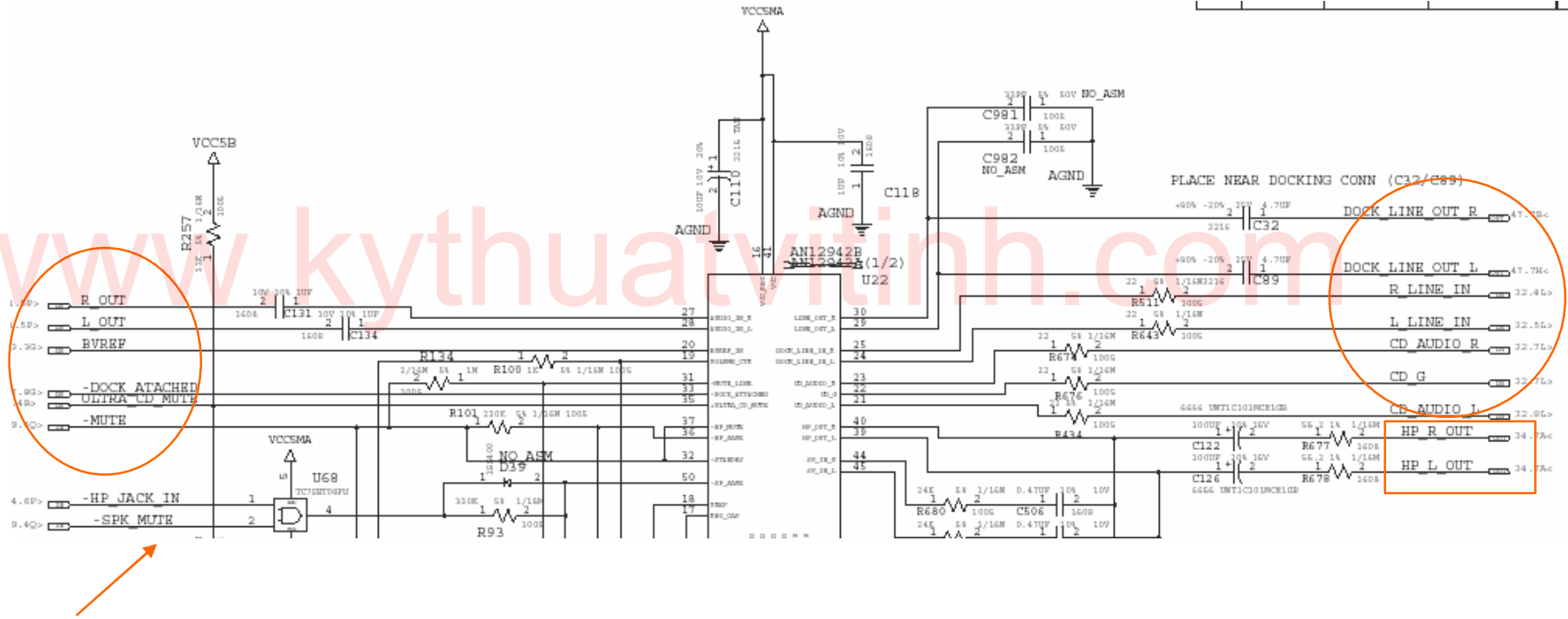

▪ Check missing component, open, short



No Work : Audio (4/4) –BEEP & SPK

Beep

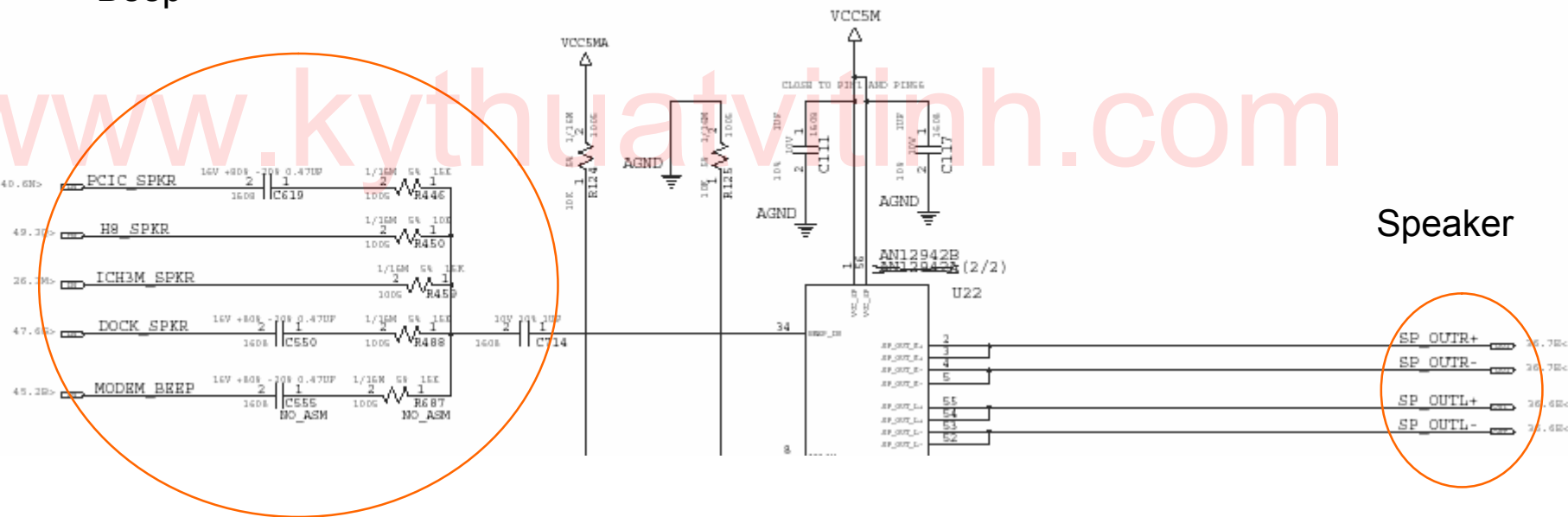

▪Check missing component, open, short



No Work : HDD

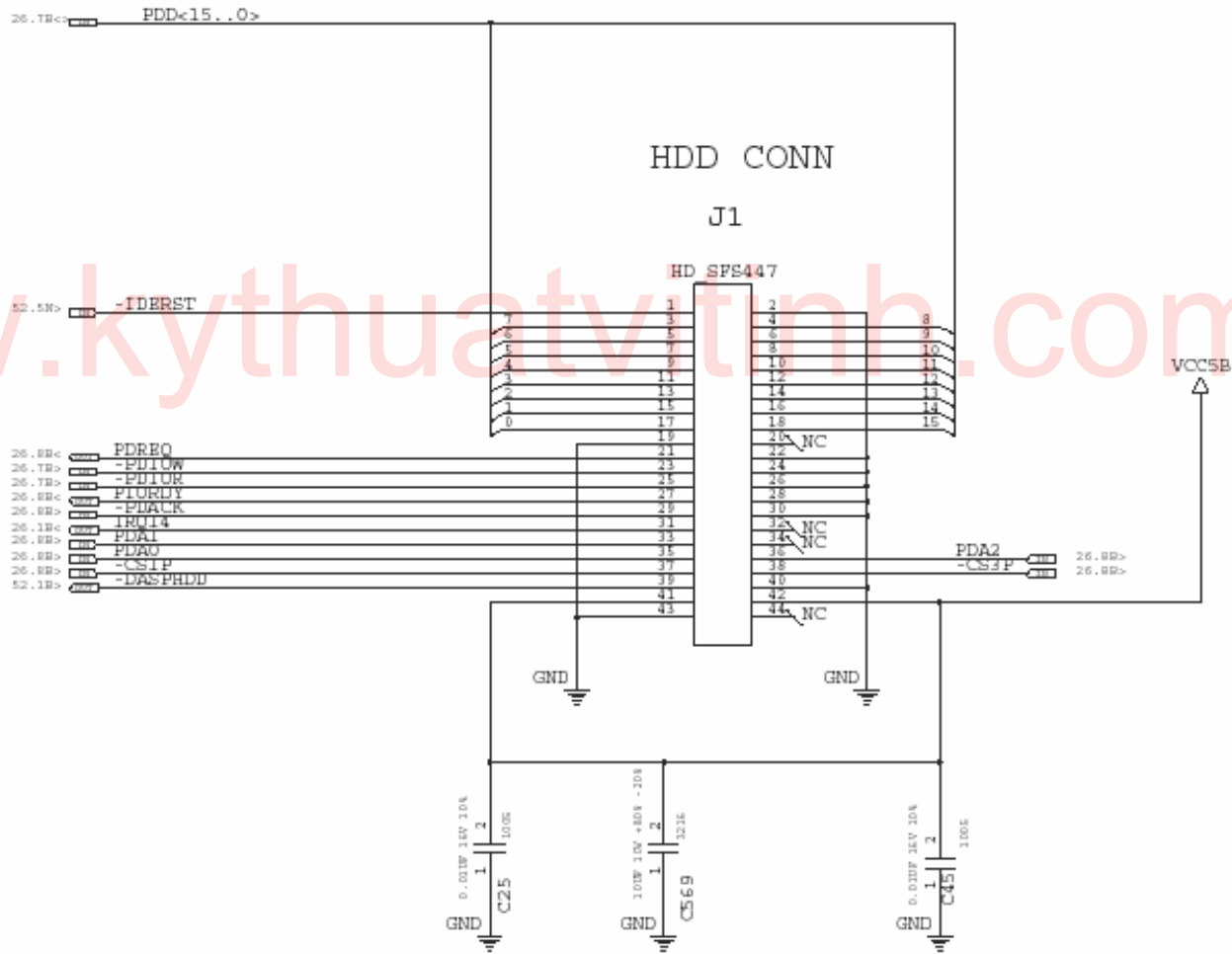

▪ Check missing component, open, short

No Work : ODD / BAY

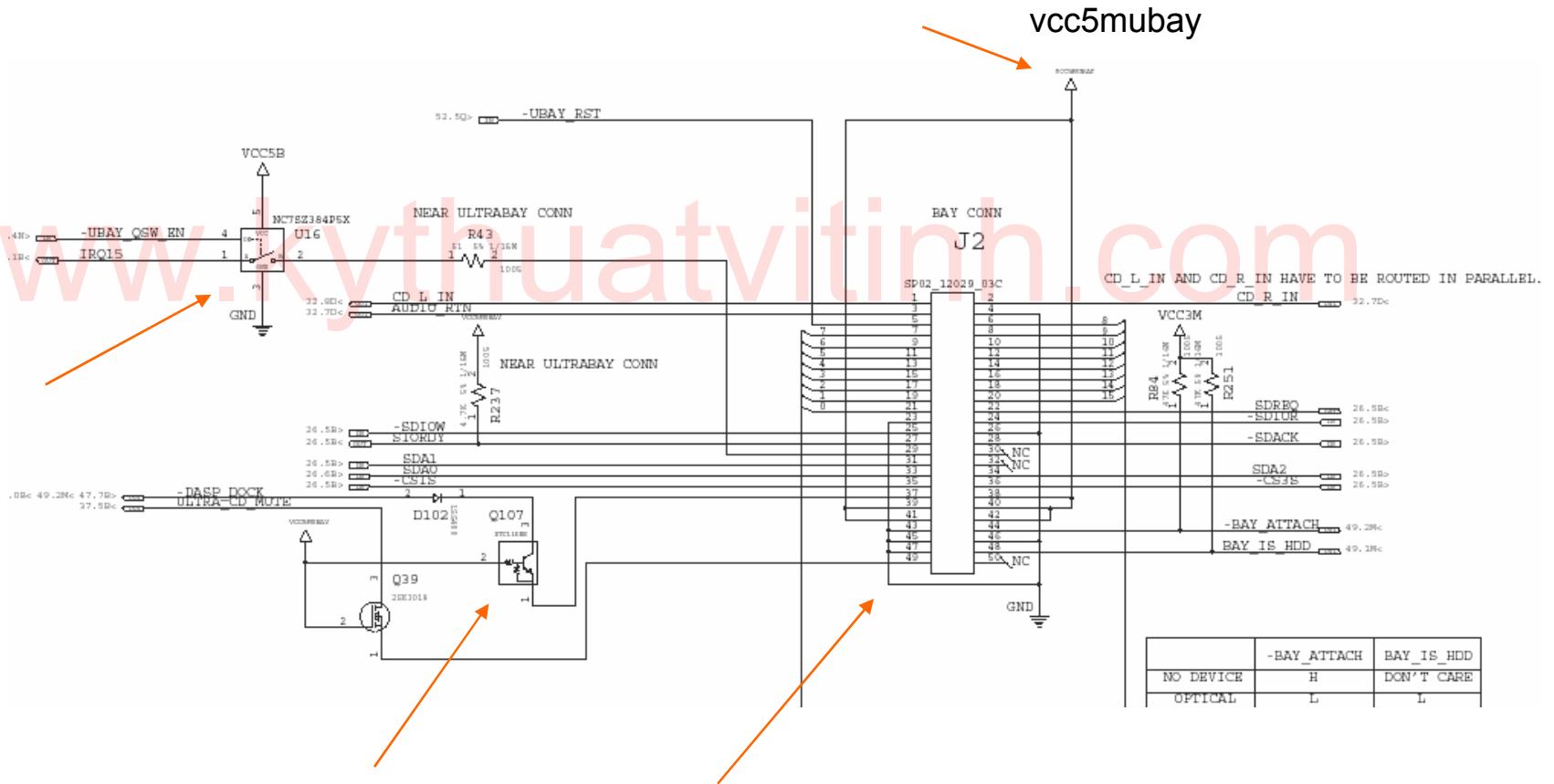

▪ Check missing component, open, short



No Work : 1394

U20
PCI4520GHK (1/2)

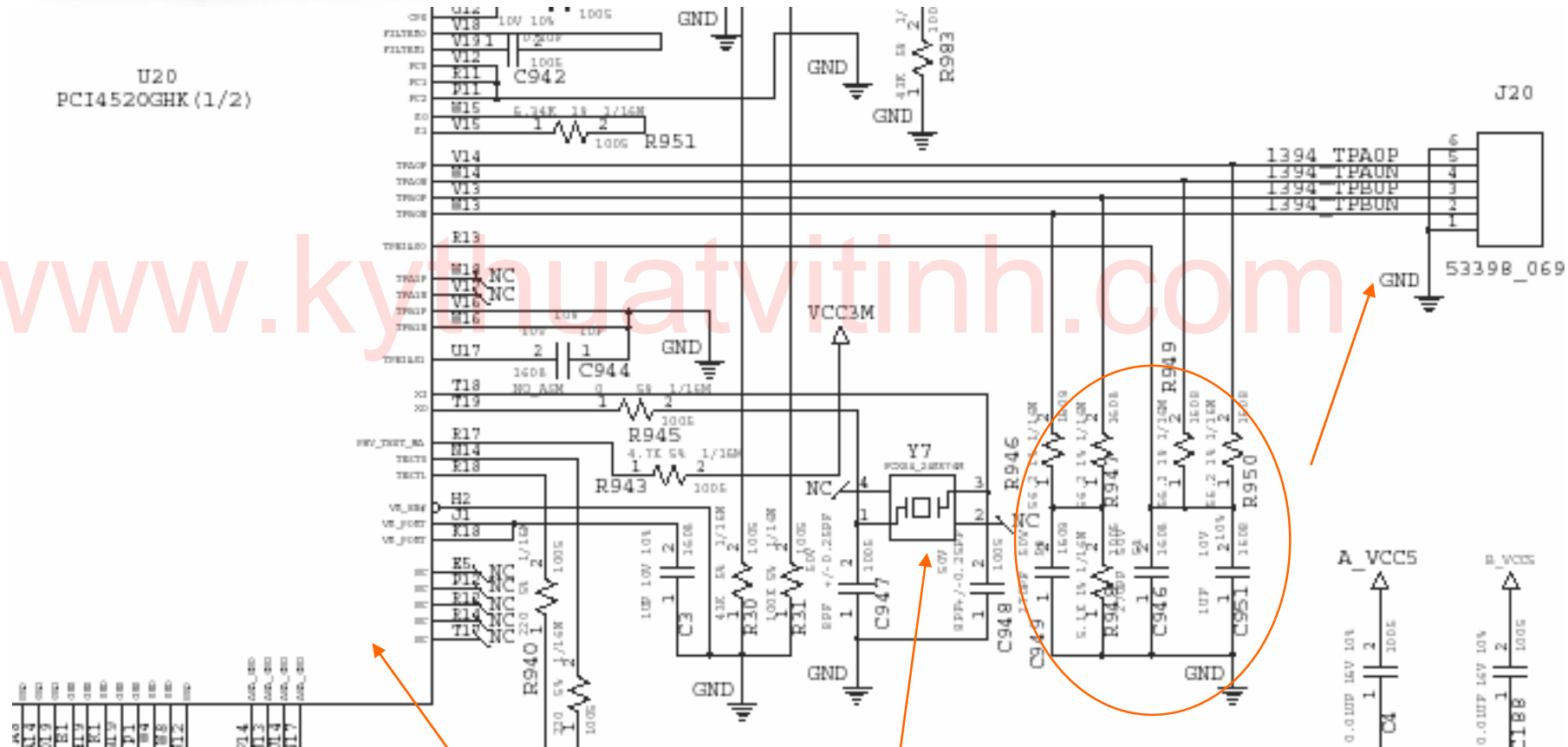

▪Check missing component, open, short

No Work : CardBus (1/3)

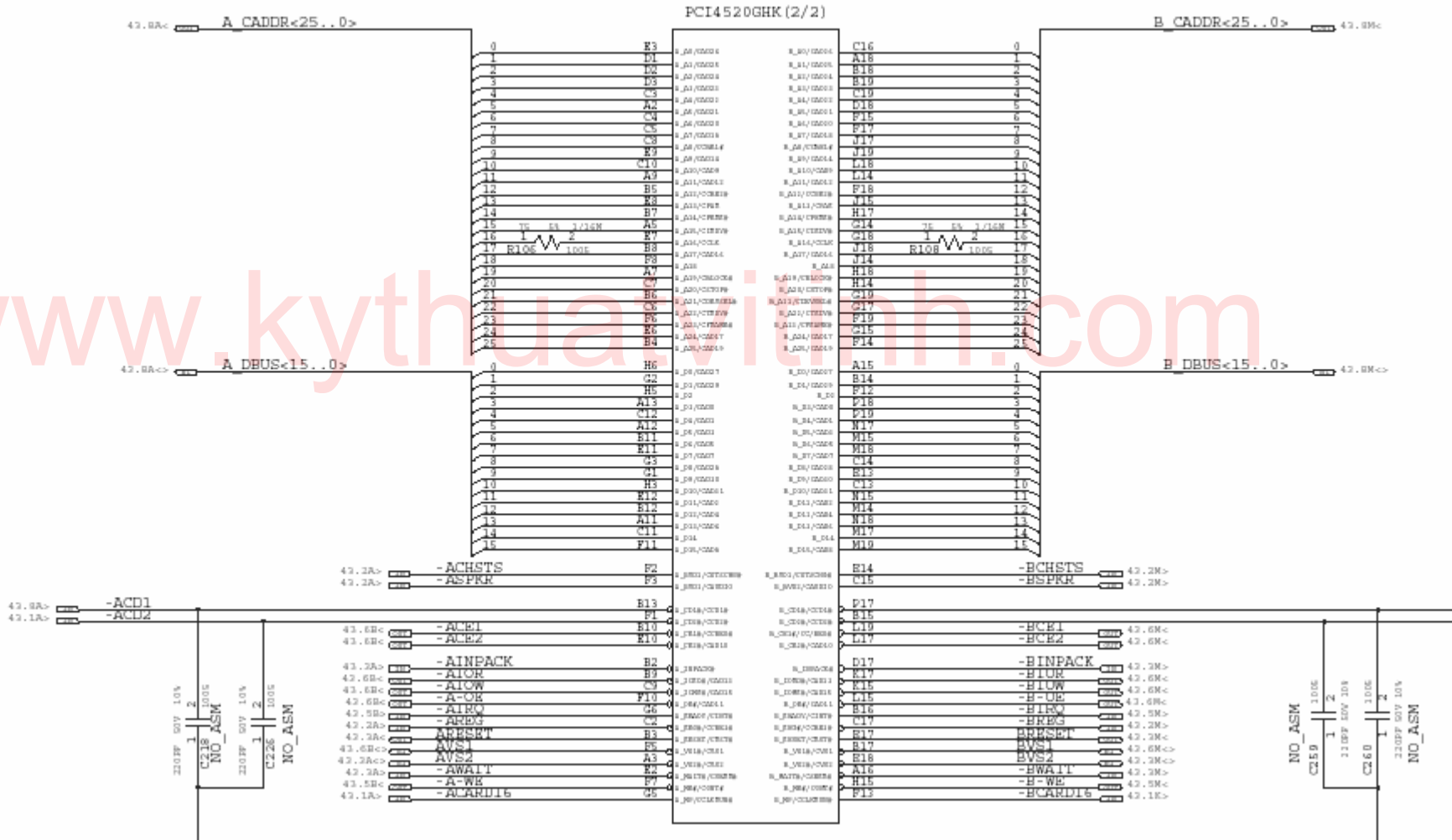

▪Check missing component, open, short

No Work : CardBus (2/3)

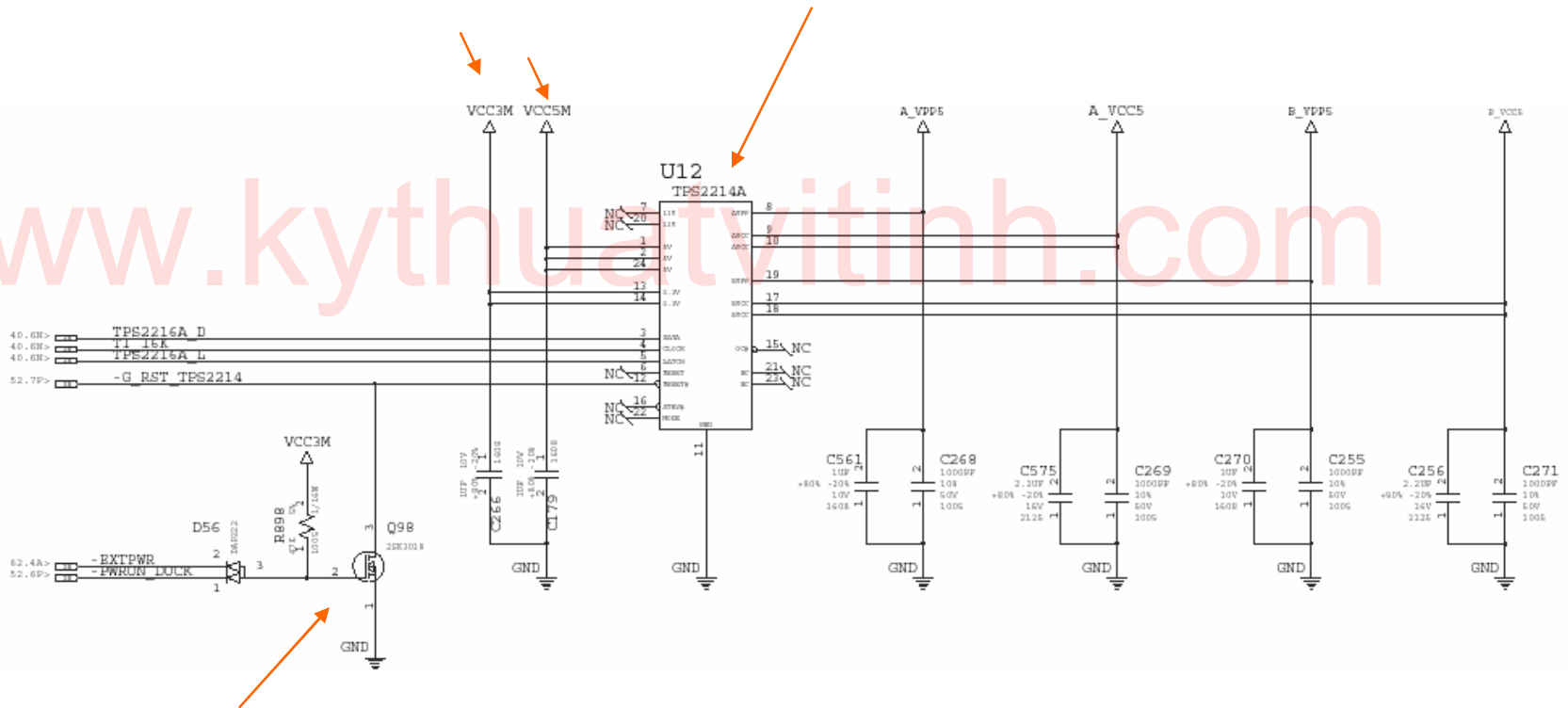

▪ Check missing component, open, short



No Work : CardBus (3/3)

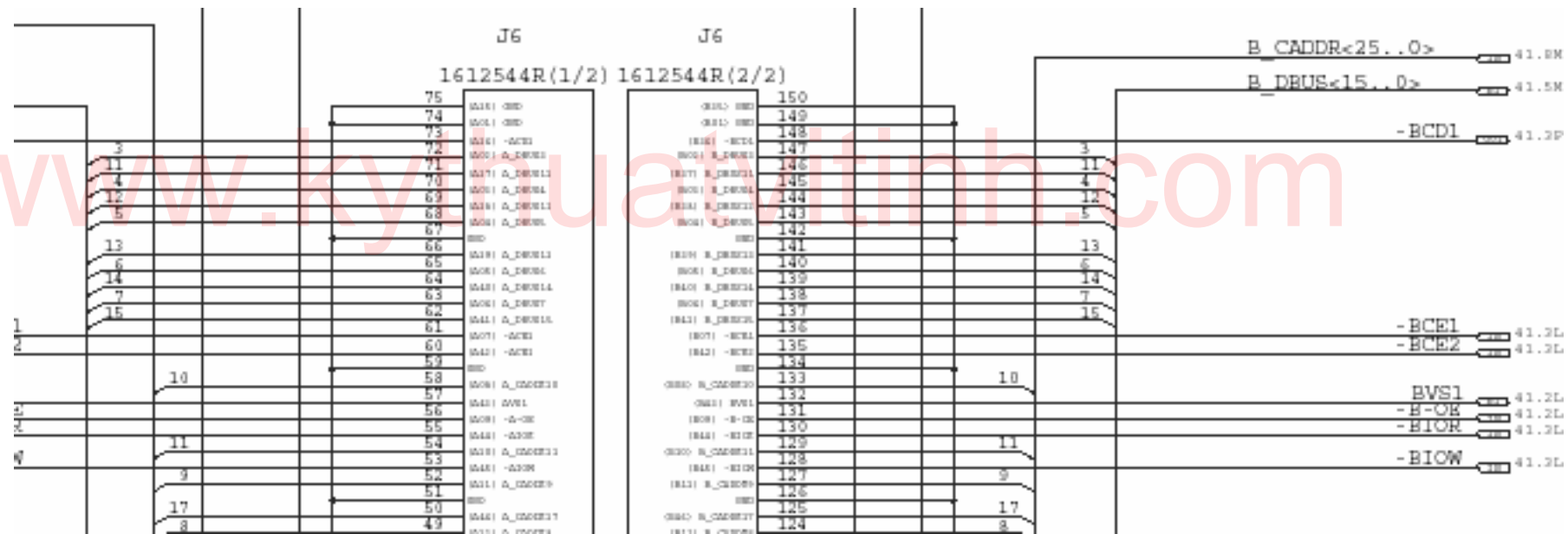

▪ Check missing component, open, short



No Work : MODEM / BLUETOOTH

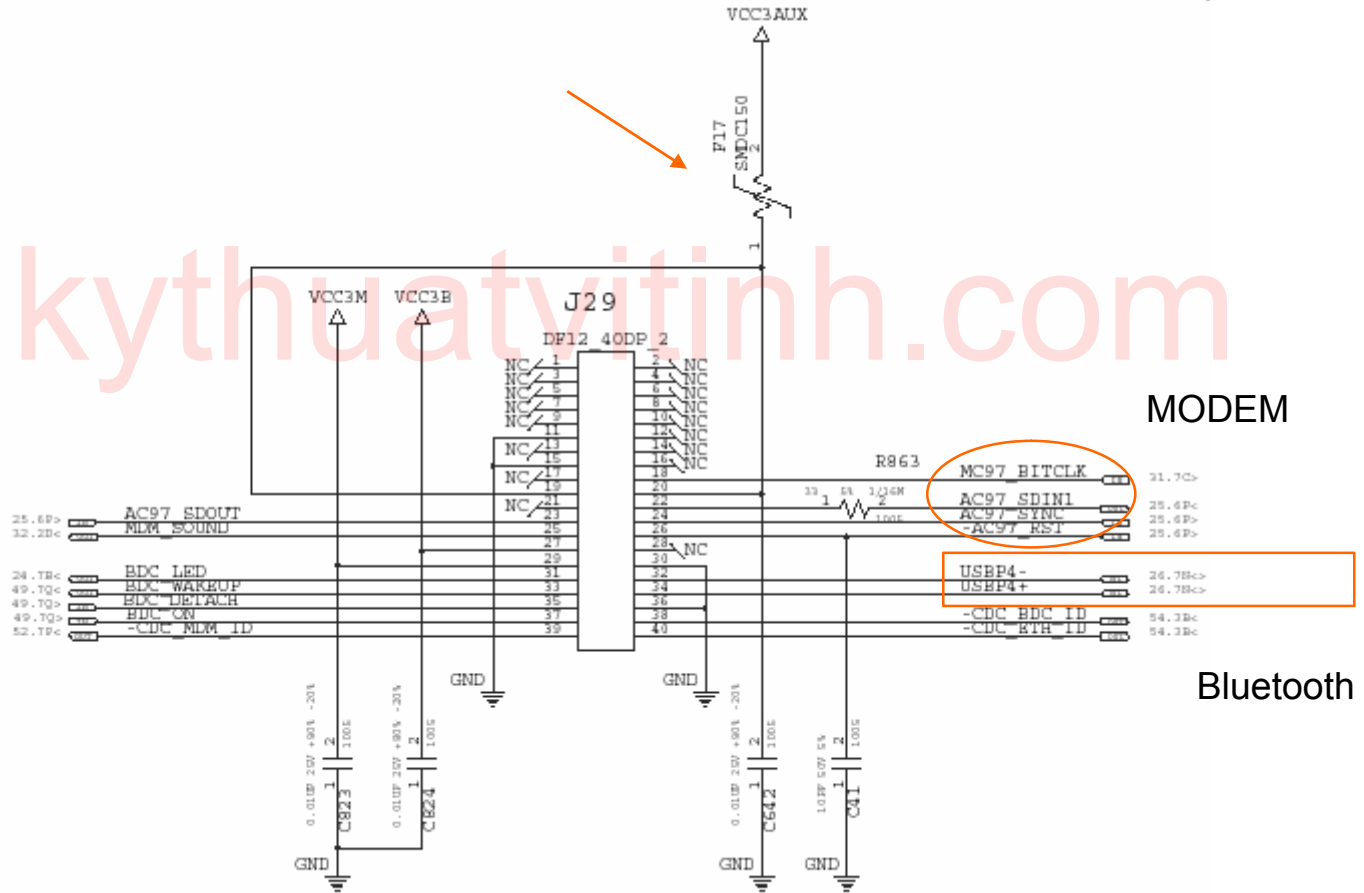

▪ Check missing component, open, short



No Work : FAN

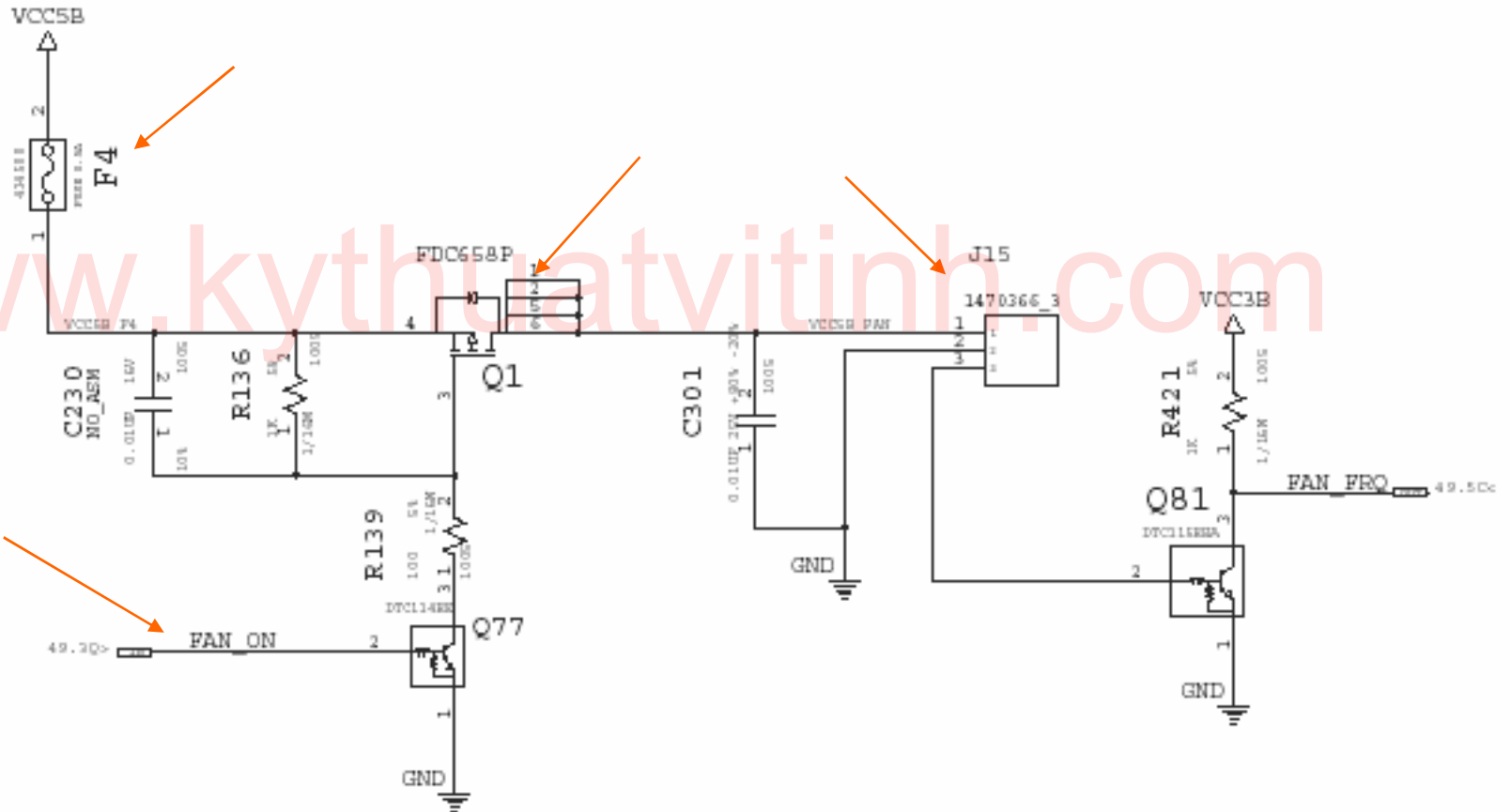

- Check missing component, open, short



No Work : IR

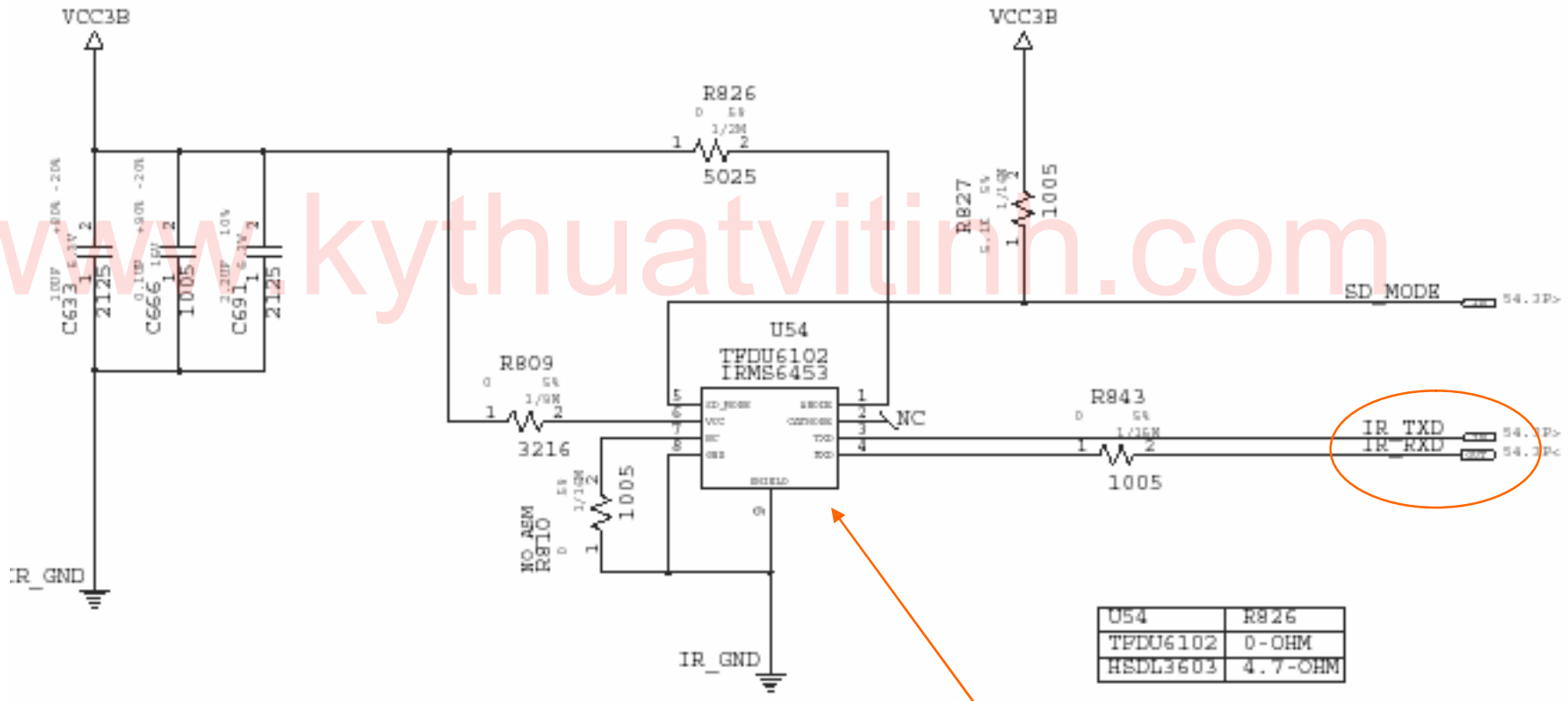

- Check solder, missing component, open, short



No Work : PARALLEL

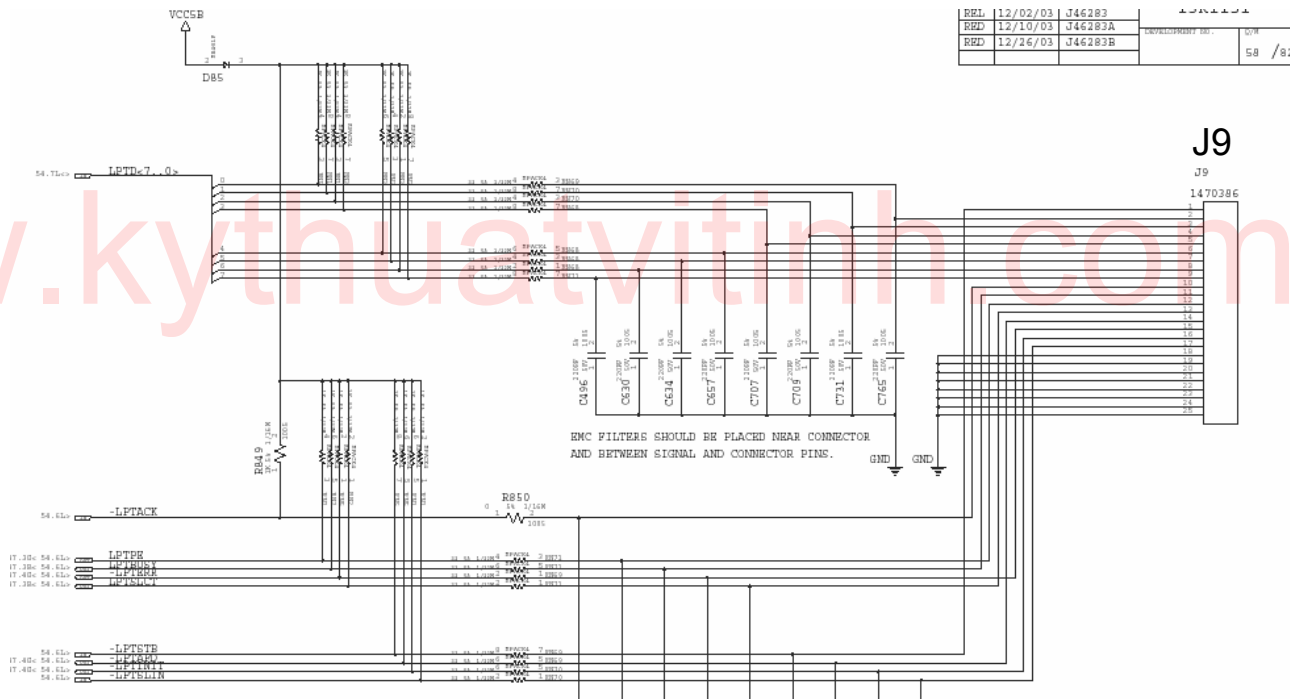

▪Check solder,missing component, open, short



No Work : SERIAL PORT

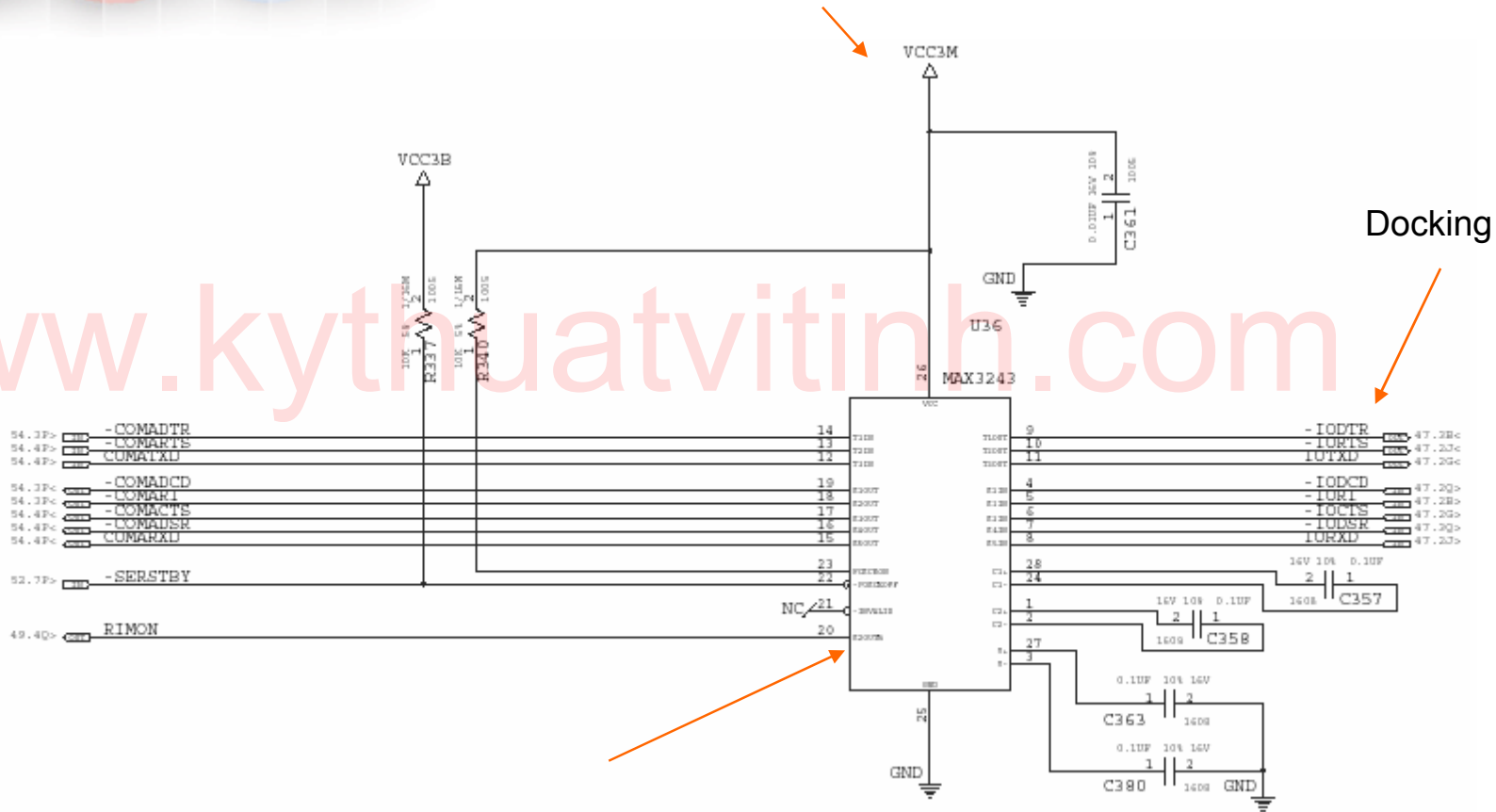

- Check solder, missing component, open, short

No Work : LAN (1/3)

▪ Check missing component, open, short

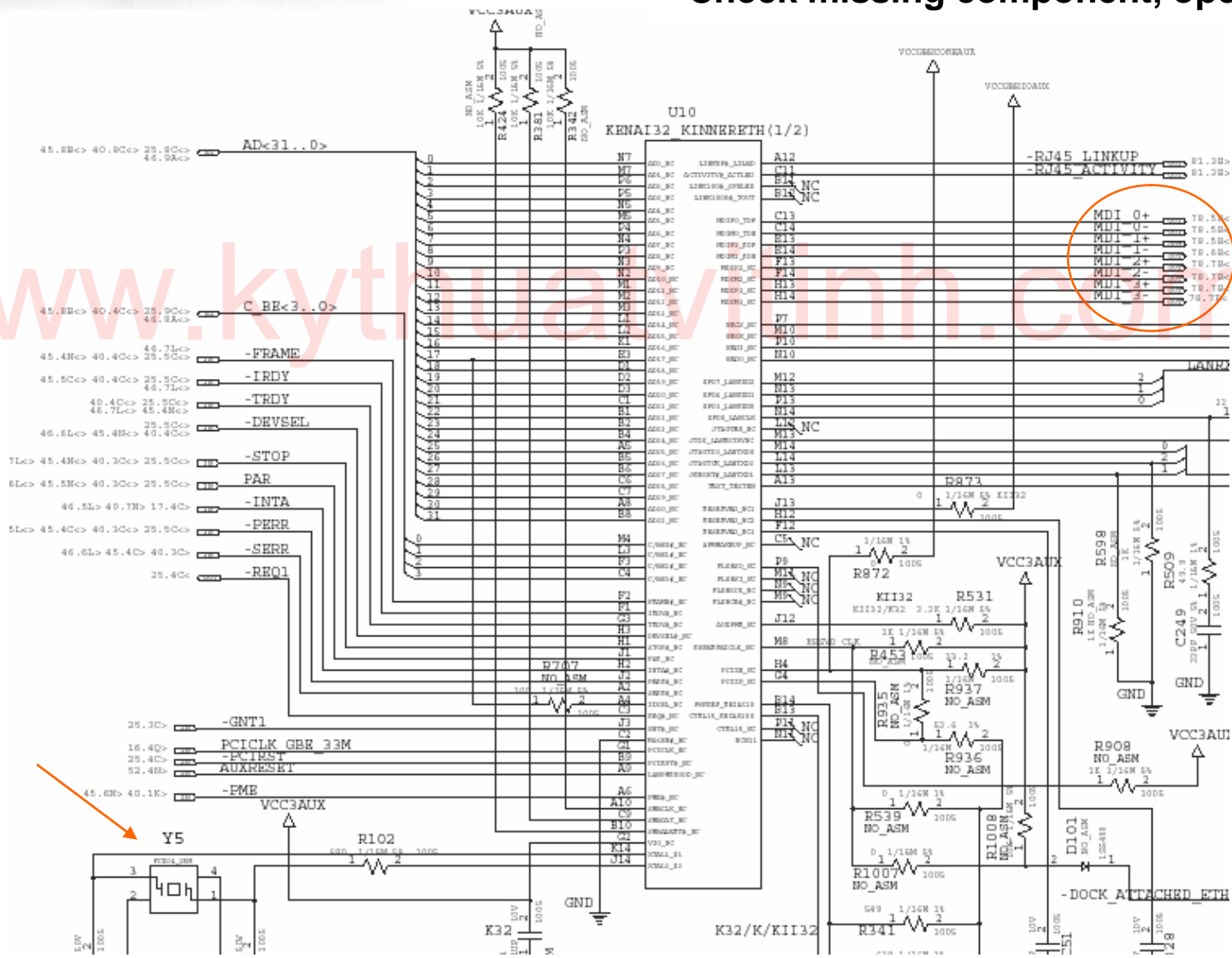

No Work : LAN (2/3)

DO NOT POPULATE MAG-1 WHEN USING
KINNERETH-R
POPULATE MAG-2 ANYTIME

THESE FOUR RESISTORS
ARE POPULATED FOR KIN

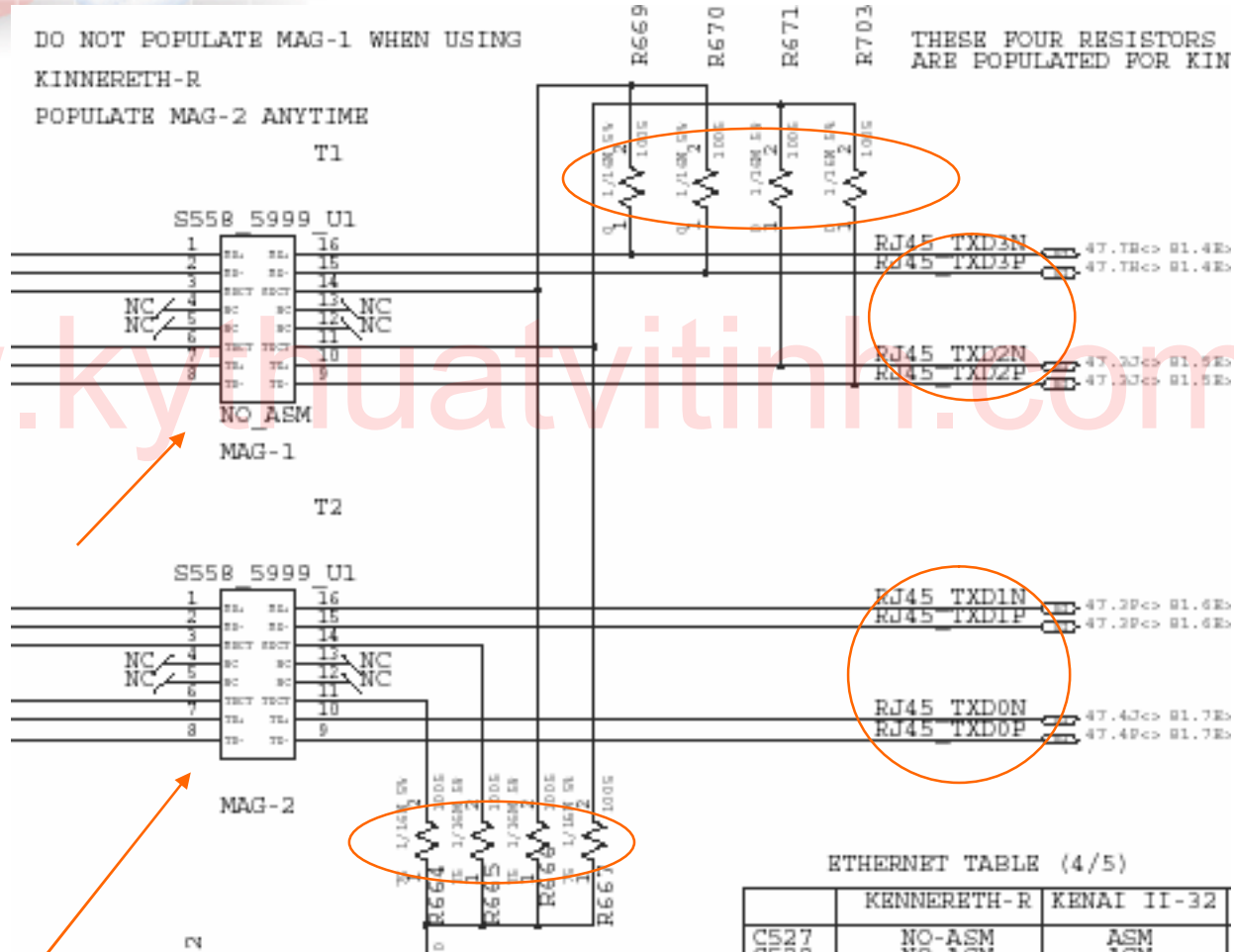

▪ Check missing component, open, short



No Work : LAN (3/3)

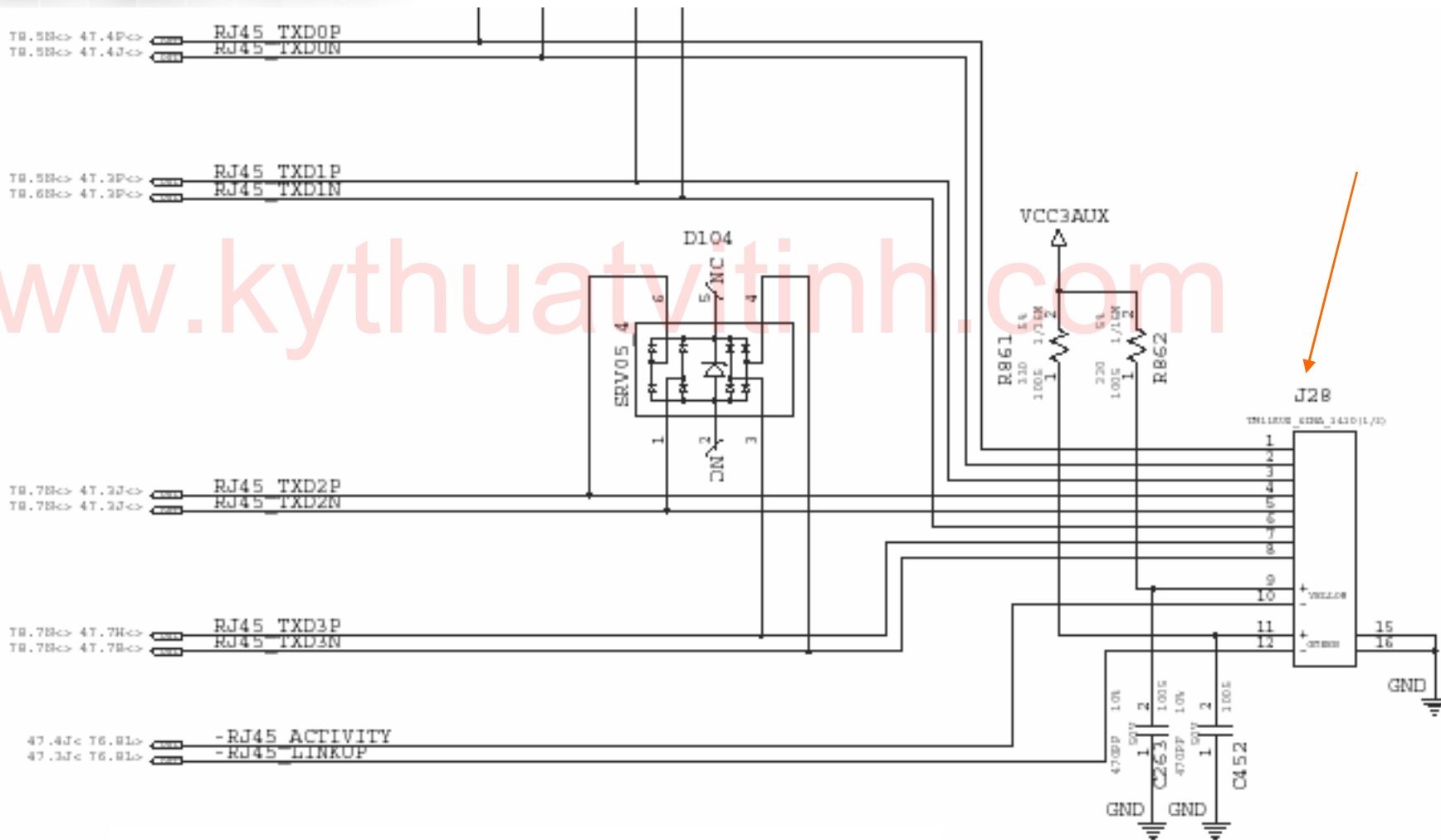

▪ Check solder, missing component, open, short

No Work : USB (1/2)

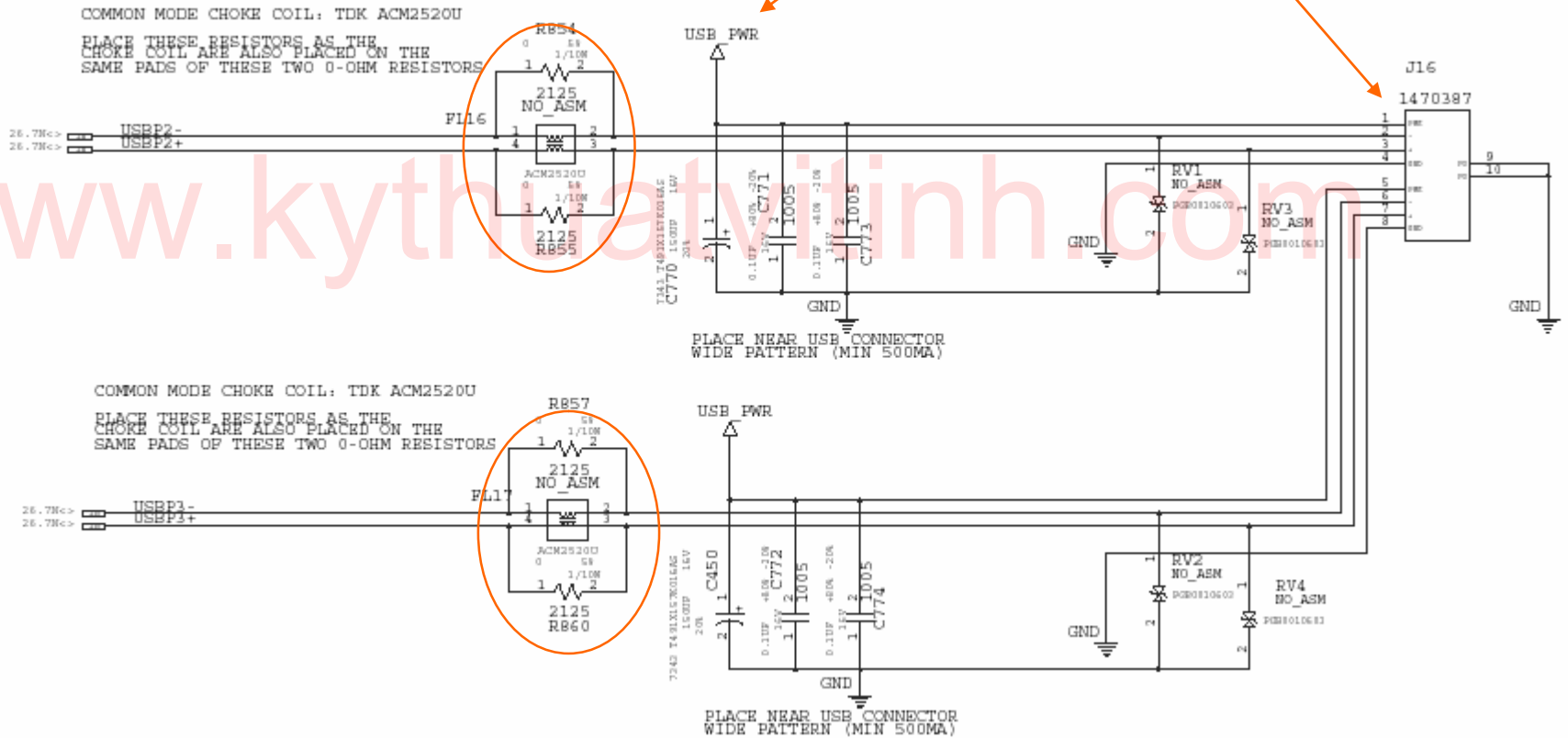

- Check solder, missing component, open, short

No Work : USB (2/2)

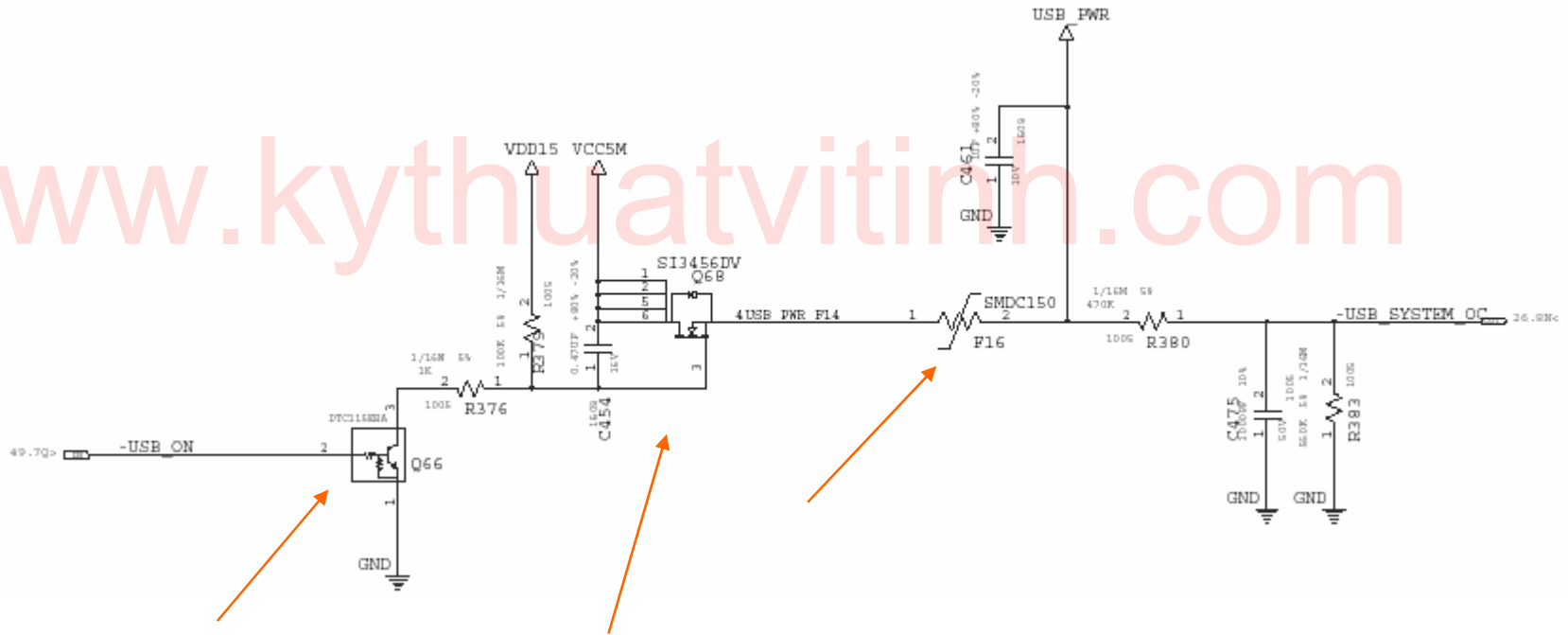

- Check solder, missing component, open, short

IMPEDANCE TABLE-checking table

All main power resistor table

Item/Measured No.	1	2	3	4	Average
VCC3SW	9K
VCC3M	12.5K
VCC5M	0.9K
VCC1R8M	12.5K
VCC3B	12.5K
VCC5B	11K
.....	
Critical signals					
-SHUTDOWN	40K
-PM_SLP_S3	11K
MPWRG	11K
BPWRG	11K
B_ON	11K
.....					



Q&A

www.kythuatvitinh.com