

## 9. BLOCK DIAGRAM

### 9.1 Main Board

The G7000/W7000 is made up of two PCBs. In lower part of the folder, there is a main board. And in the upper part of the folder, there is a FPCB. Below you can see the block diagram of both PCBs.

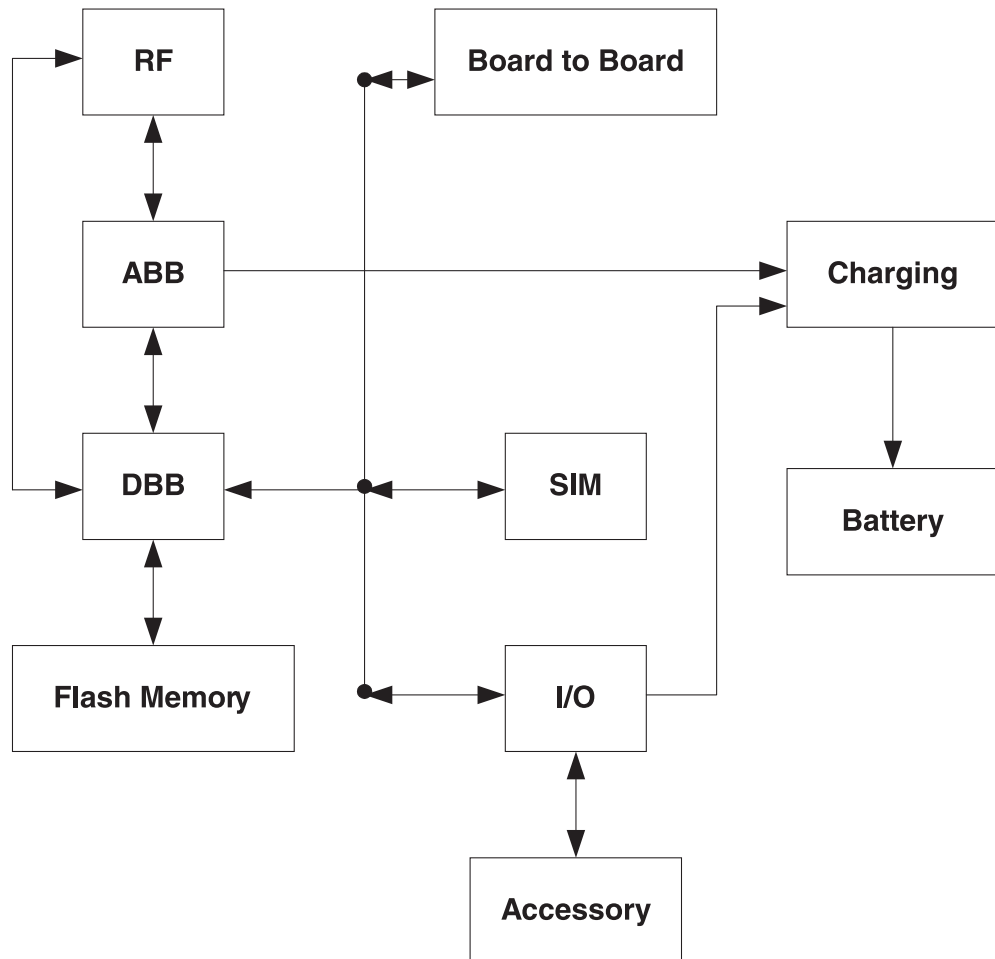

Figure 9-1. Main Block diagram.

### 9.2 FPCB

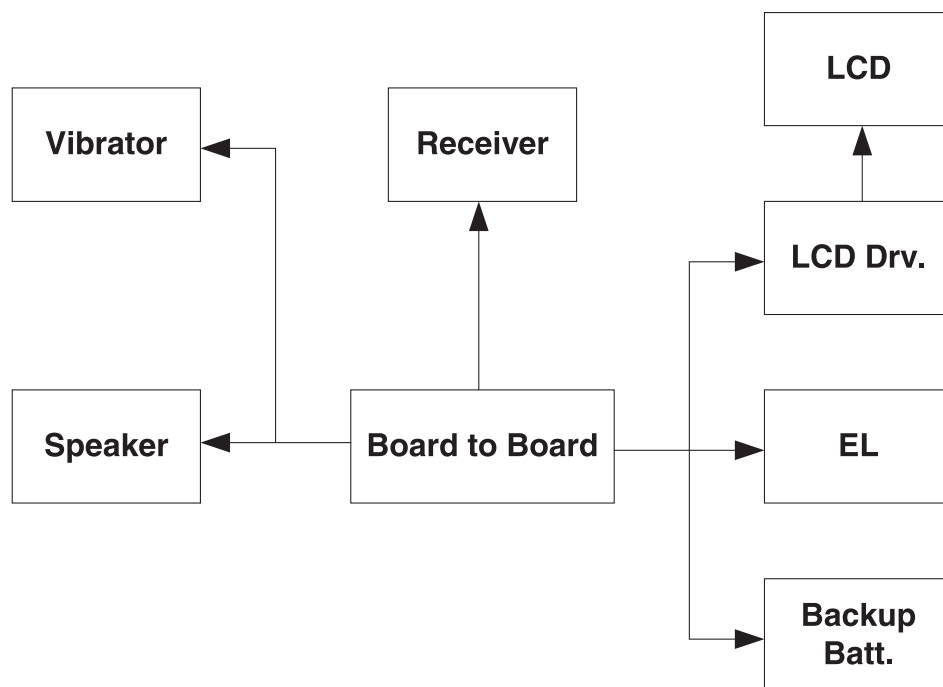

Figure 9-2. FPCB Block diagram.



## 9. BLOCK DIAGRAM

---

# 10. CIRCUIT DIAGRAM

## 10.1 BB Circuit

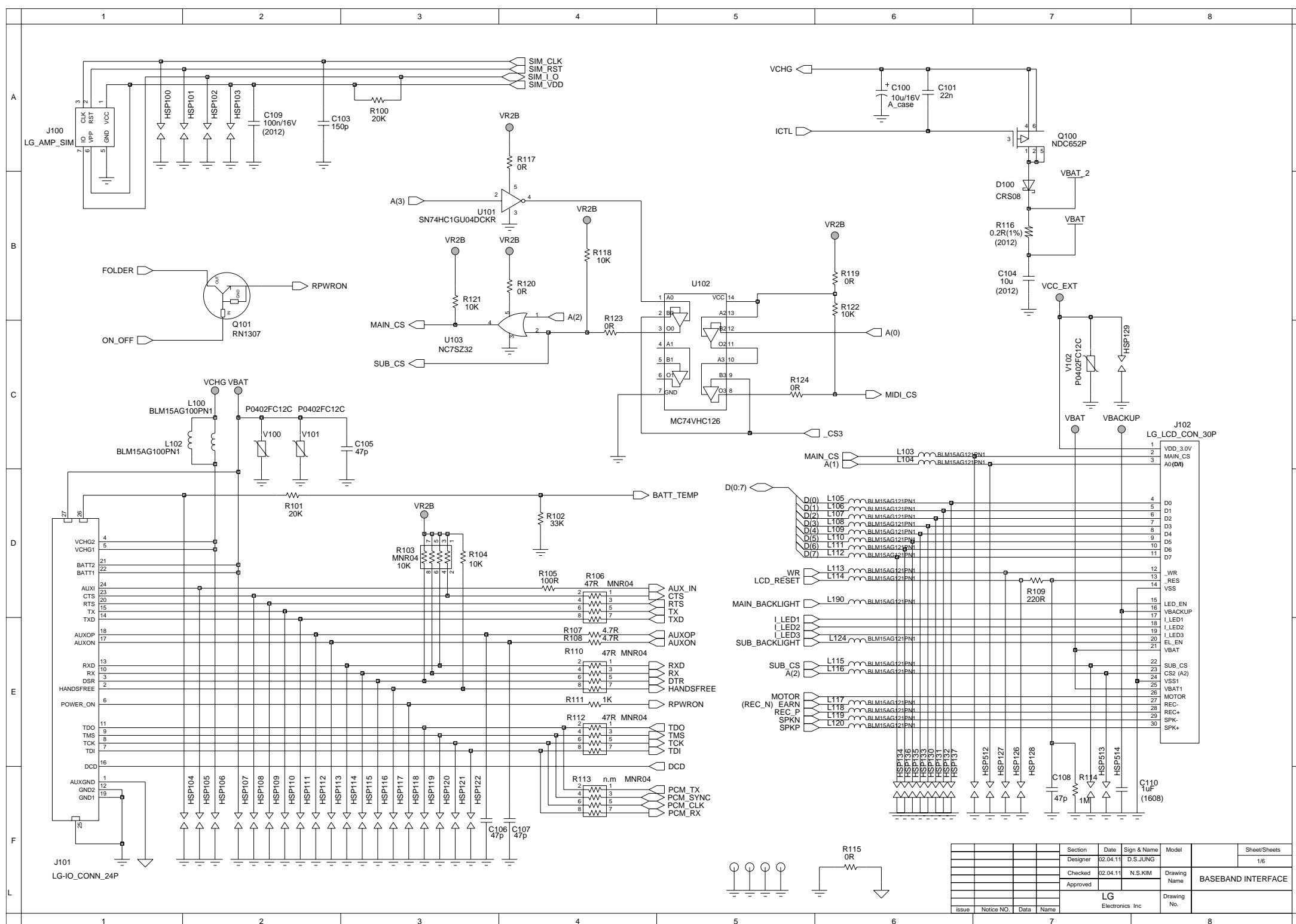

# 10. CIRCUIT DIAGRAM

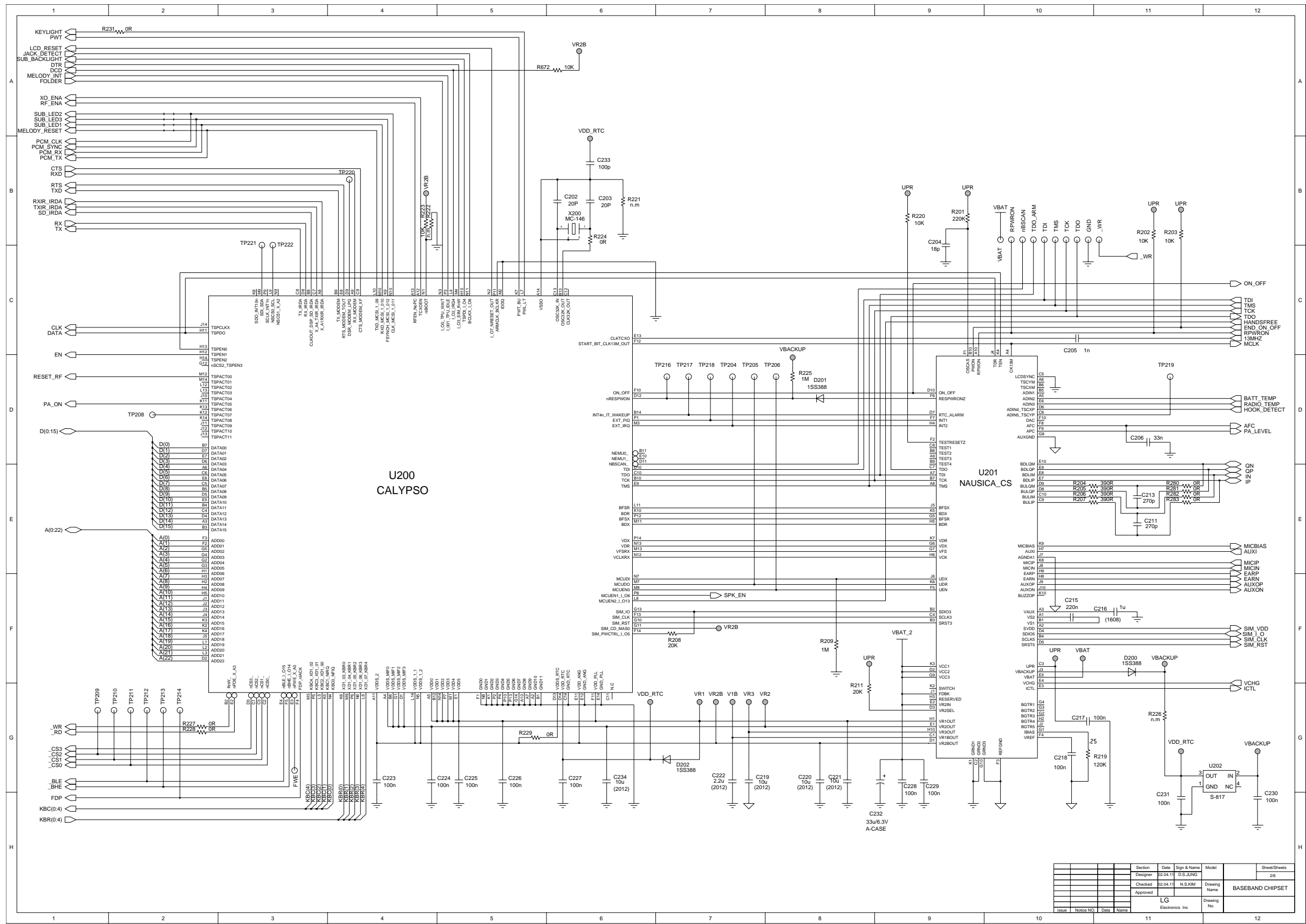

10. CIRCUIT DIAGRAM

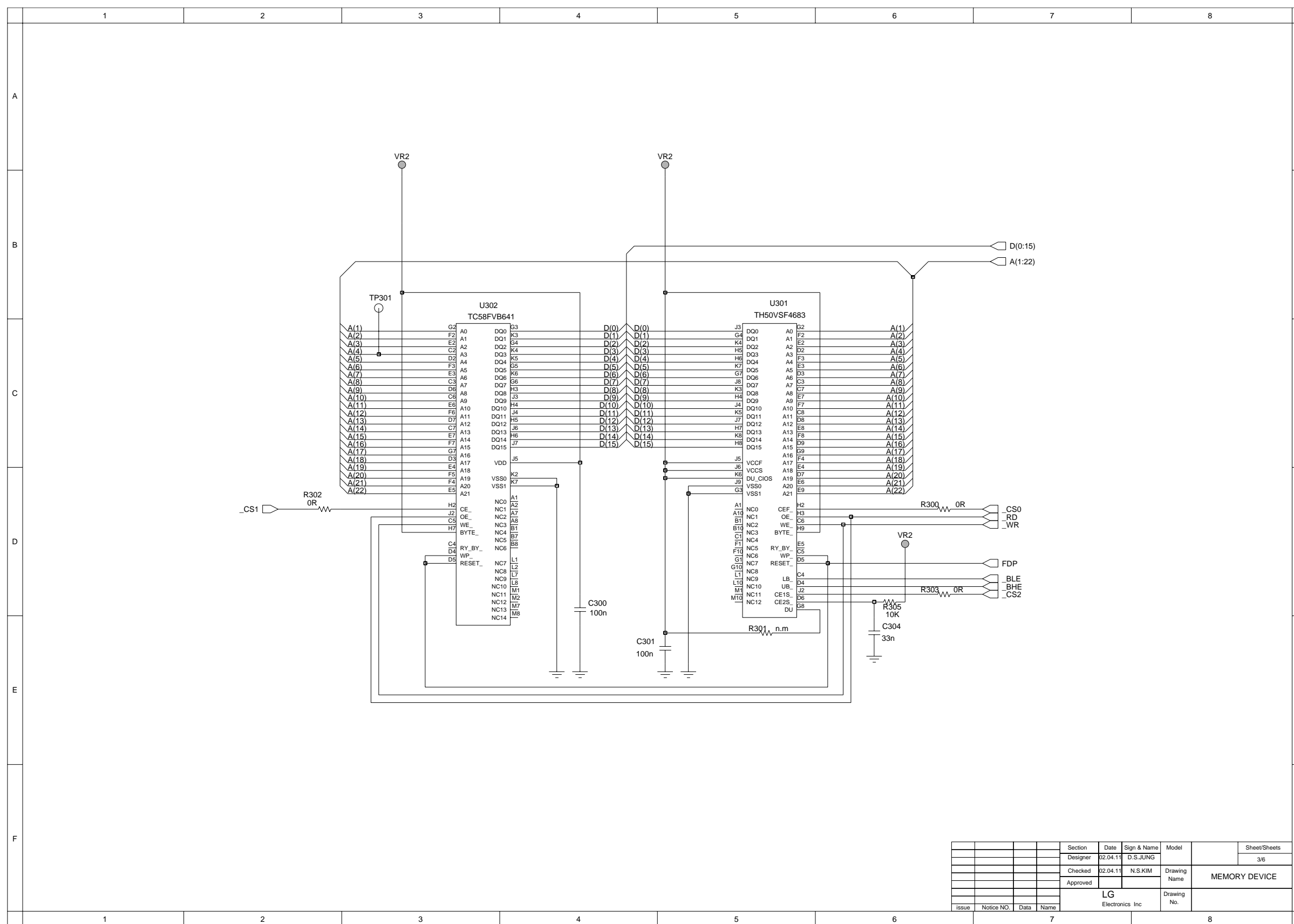

Section	Date	Sign & Name	Model	Sheet/Sheets
Designer	02.04.11	D.S.JUNG		3/6
Checked	02.04.11	N.S.KIM	Drawing Name	MEMORY DEVICE
Approved			Drawing No.	
LG Electronics Inc				
Issue	Notice NO.	Date	Name	

# 10. CIRCUIT DIAGRAM

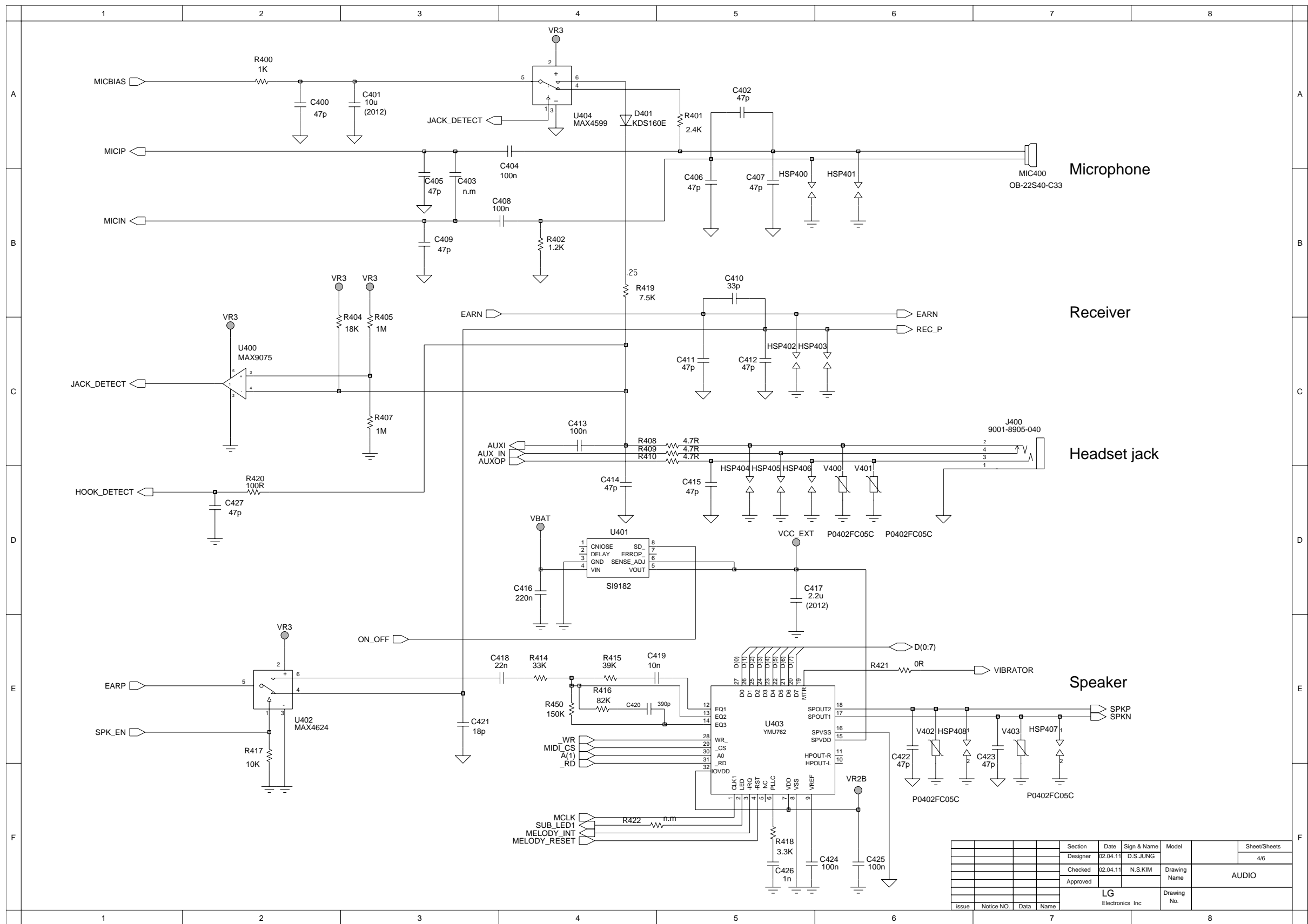



10. CIRCUIT DIAGRAM

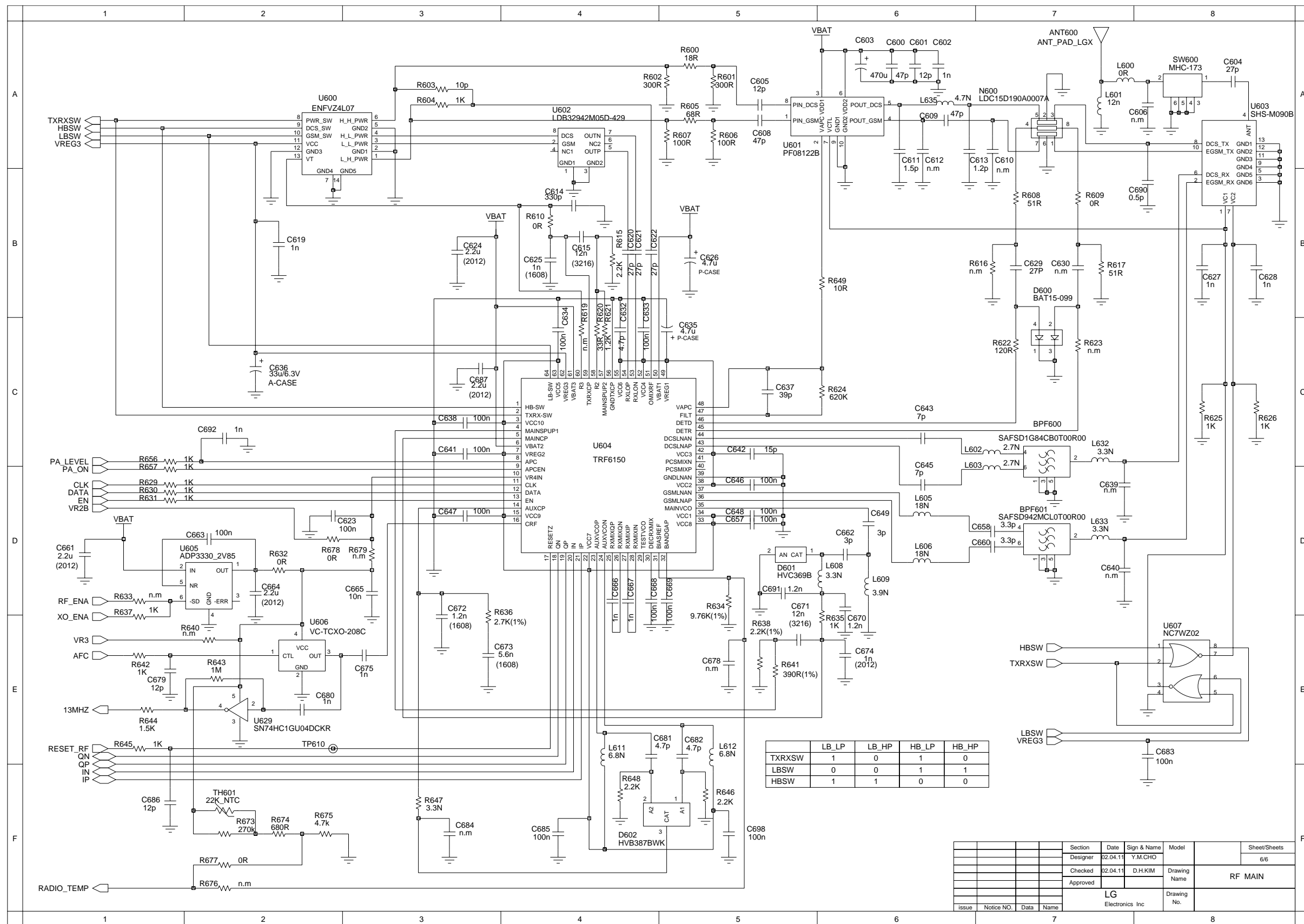

## 10. CIRCUIT DIAGRAM

### 10.2 RF Circuit

