

| | | | |
|----|-----------------------------|----|-----------------------------|
| 01 | Block Diagram | 61 | * |
| 02 | System Setting | 62 | USB CONN |
| 03 | POWER SEQUENCE | 63 | * |
| 04 | CPU-Penryn(HOST) | 64 | * |
| 05 | CPU-Penryn(PWR) | 65 | * |
| 06 | * | 66 | * |
| 07 | Cantiga(HOST) | 67 | DEBUG CONN |
| 08 | Cantiga(DMI & CFG) | 68 | DC & BAT IN |
| 09 | Cantiga(GRAPHIC) | 69 | * |
| 10 | Cantiga(DDR2) | 70 | * |
| 11 | Cantiga(PWR) | 71 | * |
| 12 | Cantiga(PWR2) | 72 | SATA-HDD & ODD |
| 13 | Cantiga(GND) | 73 | * |
| 14 | * | 74 | HOLE & Spring |
| 15 | SB-ICH9M(1)_SATA | 75 | * |
| 16 | SB-ICH9M(2)_PCIE/USB | 76 | EXPRESS GATE |
| 17 | SB-ICH9M(3)_PM/GPIO | 77 | History |
| 18 | SB-ICH9M(PWR) | 78 | * |
| 19 | * | 79 | * |
| 20 | DDR2 SO-DIMM0 | 80 | POWER_VCORE |
| 21 | DDR2 SO-DIMM1 | 81 | POWER_SYSTEM |
| 22 | DDR2 TERMINATION | 82 | POWER_I/O_1.5VS & 1.05VS |
| 23 | * | 83 | POWER_I/O_DDR & VTT |
| 24 | * | 84 | POWER_I/O(Empty) |
| 25 | * | 85 | POWER_VGA_CORE&1.1VS(Empty) |
| 26 | * | 86 | POWER_MCH_CORE(Empty) |
| 27 | * | 87 | POWER_CHARGER |
| 28 | * | 88 | POWER_DETECT |
| 29 | * | 89 | POWER_LOAD SWITCH |
| 30 | EC_IT8512E-L(1/2) | 90 | POWER_PROTECT |
| 31 | EC_IT8512E-L(2/2) | 91 | POWER_SIGNAL |
| 32 | CRT | 92 | POWER_FLOWCHART |
| 33 | LVDS & INVERTER CONNECTOR | 93 | POWER_HISTORY |
| 34 | BT | | |
| 35 | * | | |
| 36 | CONEXANT CX20582 | | |
| 37 | CONEXANT_HP/MIC | | |
| 38 | THER SENSOR & FAN | | |
| 39 | CLOCK GEN-ICS9LPR363DGLF-T | | |
| 40 | * | | |
| 41 | Switch Button & LED | | |
| 42 | DISCHARGE | | |
| 43 | * | | |
| 44 | PCI-E LAN_RTL8111C | | |
| 45 | MDC & RJ45+11 | | |
| 46 | Mini card_WLAN+3G | | |
| 47 | * | | |
| 48 | * | | |
| 49 | * | | |
| 50 | * | | |
| 51 | * | | |
| 52 | * | | |
| 53 | CardReader & SIM CONN & TPM | | |
| 54 | NEWCARD | | |
| 55 | * | | |
| 56 | HDA level shifter | | |
| 57 | iHDMI | | |
| 58 | * | | |
| 59 | * | | |
| 60 | * | | |

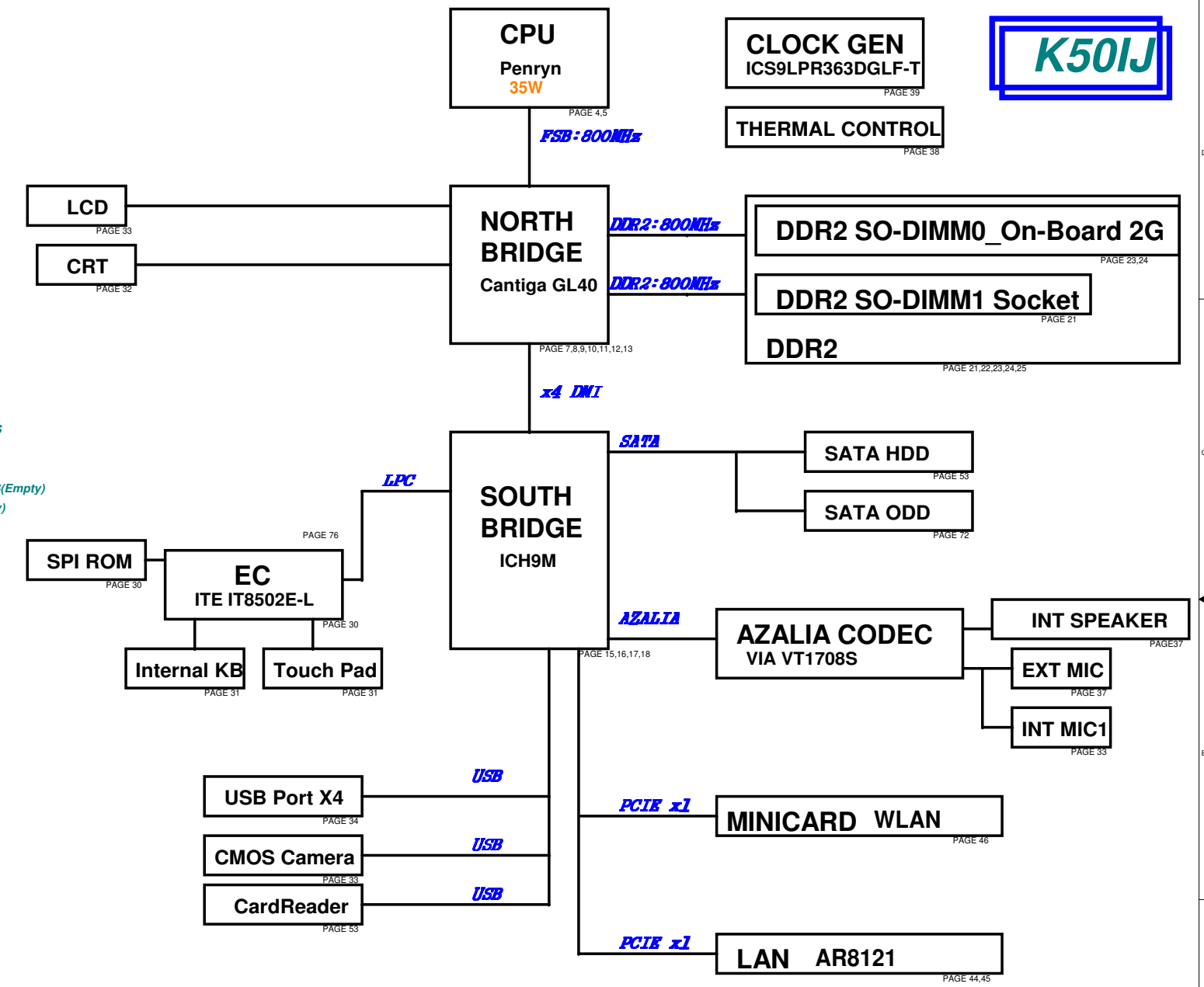

INT PU*: PU or PD in special time
 GPIO33 Internal Pull High, Go Low= Flash -_ \-
 Descriptor Security will be overridden

| ICH9-M GPIO | Use As | Signal Name | Power |
|-------------|--------|-----------------------------|--------|
| GPIO 00 | GPI | PMSYNC#(programmed as GPO) | +3VS |
| GPIO 01 | GPI | DOCKING_DET# EXT PU | +3VS |
| GPIO [2:5] | GPI | PCI_INT[E:H]#EXT PU | +5VS |
| GPIO 06 | GPI | - EXT PU | +3VS |
| GPIO 07 | GPO | SEL_VID2 - | +3VS |
| GPIO 08 | GPI | EXT_SMI# EXT PU | +3VSUS |
| GPIO 09 | Native | WOL_EN | +3VSUS |
| GPIO 10 | GPI | SUS_PWR_ACK EXT PU | +3VSUS |
| GPIO 11 | Native | EXT_SCI#(Programmed as GPI) | +3VSUS |
| GPIO 12 | GPO | - | +3VSUS |
| GPIO 13 | GPI | CB_SD#(Programmed as GPO) | +3VSUS |
| GPIO 14 | GPI | AC_PRESENT EXT PD | +3VSUS |
| GPIO 15 | Native | STP_PCI# | +3VSUS |
| GPIO 16 | Native | PM_DPRS_LVPR INT PD* | +3VS |
| GPIO 17 | GPI | WLAN_LED(Programmed as GPO) | +3VS |
| GPIO 18 | GPO | SEL_VID3 - | +3VS |
| GPIO 19 | GPO | SEL_VID0 - | +3VS |
| GPIO 20 | GPO | SEL_VID4 - INT PD* | +3VS |
| GPIO 21 | GPO | VID_SW - High Active | +3VS |
| GPIO 22 | GPI | BT_DET# EXT PU | +3VS |
| GPIO 23 | Native | ICH_LDRQ1# INT PU | +3VS |
| GPIO 24 | GPO | WLAN_ON | +3VSUS |
| GPIO 25 | Native | STP_CPU# | +3VSUS |
| GPIO 26 | Native | PM_S4_STATE# | +3VSUS |
| GPIO 27 | GPO | SEL_VID5 | +3VSUS |
| GPIO 28 | GPO | SEL_VID6 | +3VSUS |
| GPIO 29 | Native | USB_OC#5 | +3VSUS |
| GPIO 30 | Native | USB_OC#6 | +3VSUS |
| GPIO 31 | Native | USB_OC#7 | +3VSUS |
| GPIO 32 | GPO | PM_CLKRUN# | +3VS |
| GPIO 33 | GPO | - INT PU* | +3VS |
| GPIO 34 | GPO | - | +3VS |
| GPIO 35 | GPO | - | +3VS |
| GPIO 36 | GPO | SEL_VID1 - | +3VS |
| GPIO 37 | GPI | PCB_ID0 | +3VS |
| GPIO 38 | GPI | PCB_ID1 | +3VS |
| GPIO 39 | GPI | PCB_ID2 | +3VS |
| GPIO 40 | Native | USB_OC01# | +3VSUS |
| GPIO 41 | Native | USB_OC2# | +3VSUS |
| GPIO 42 | Native | USB_OC3# | +3VSUS |
| GPIO 43 | Native | USB_OC4# | +3VSUS |
| GPIO 44 | Native | CLK_DEC# | +3VSUS |
| GPIO 45 | Native | CLK_ACC | +3VSUS |
| GPIO 46 | Native | NEWCARD_OC# | +3VSUS |
| GPIO 47 | Native | UNDOCKING# | +3VSUS |
| GPIO 48 | GPI | EMAIL_LED# EXT PU | +3VS |
| GPIO 49 | GPO | GPU_RST# INT PU* | +3VS |
| GPIO 50 | Native | PCI_REQ#1 | +5VS |
| GPIO 51 | Native | PCI_GNT#1 INT PU* | +3VS |
| GPIO 52 | Native | PCI_REQ#2 | +5VS |
| GPIO 53 | Native | PCI_GNT#2 INT PU* | +3VS |
| GPIO 54 | Native | PCI_REQ#3 | +5VS |
| GPIO 55 | Native | PCI_GNT#3 INT PU* | +3VS |
| GPIO 56 | GPI | - EXT PU | +3VSUS |
| GPIO 57 | GPI | - EXT PU | +3VSUS |
| GPIO 58 | GPI | SPI_CS#1 INT PU* | +3VSUS |
| GPIO 59 | Native | USB_OC0# | +3VSUS |
| GPIO 60 | Native | LINKALERT# | +3VSUS |

| EC GPIO | Use As | Signal Name | Power |
|---------|--------|----------------|-------|
| GPA0 | GPO | PWR_LED_UP# | |
| GPA1 | GPO | CHG_LED_UP# | |
| GPA2 | GPO | BATSEL_3S# | |
| GPA3 | - | - | |
| GPA4 | GPO | LCD_BL_PWM | |
| GPA5 | GPO | FANO_PWM | |
| GPA6 | GPO | BAT1_CNT1# | |
| GPA7 | GPO | BAT2_CNT1# | |
| GPB0 | GPO | CHG_EN# | |
| GPB1 | GPO | PRECHG | |
| GPB2 | GPI | DISTP# | |
| GPB3 | ALT | SMB0_CLK | |
| GPB4 | ALT | SMB0_DAT | |
| GPB5 | OD | A20GATE | |
| GPB6 | OD | RCIN# | |
| GPB7 | GPO | PM_RSMRST# | |
| GPC0 | GPI | MARATHON# | |
| GPC1 | ALT | SMB1_CLK | |
| GPC2 | ALT | SMB1_DAT | |
| GPC3 | GPO | PM_PWRBTN# | |
| GPC4 | ALT | AC_IN_OC# | |
| GPC5 | GPO | OP_SD# | |
| GPC6 | ALT | BAT1_IN_OC# | |
| GPC7 | GPO | 3G_ON# | |
| GPD0 | GPI | PWRLIMIT# | |
| GPD1 | ALT | PM_S4_STATE# | |
| GPD2 | ALT | BUF_PLT_RST# | |
| GPD3 | OD | EXT_SCI# | |
| GPD4 | OD | EXT_SMI# | |
| GPD5 | GPO | LCD_BACKOFF# | |
| GPD6 | ALT | FANO_TACH | |
| GPD7 | GPI | COLOREN# | |
| GPE0 | GPO | VSUS_ON | |
| GPE1 | GPO | SUSC_EC# | |
| GPE2 | GPO | SUSB_EC1# | |
| GPE3 | GPO | CPU_VRON | |
| GPE4 | ALT | PWR_SW# | |
| GPE5 | ALT | BAT2_IN_OC# | |
| GPE6 | GPI | LID_SW# | |
| GPE7 | GPO | PM_THERM# | |
| GPFF0 | GPI | BLUETOOTH# | |
| GPFF1 | GPI | WIRELESS# | |
| GPFF2 | ALT | PS2_CLK_5S_PD | |
| GPFF3 | ALT | PS2_DATA_5S_PD | |
| GPFF4 | ALT | TP_CLK | |
| GPFF5 | ALT | TP_DAT | |
| GPFF6 | GPO | THRO_CPU | |
| GPFF7 | GPO | PS_SHDN# | |
| GPG0 | GPI | INSTANT_ON# | |
| GPG1 | ALT | PM_SUSB# | |
| GPG2 | GPO | BAT1_CNT2# | |
| - | - | - | |
| - | - | - | |

| EC GPIO | Use As | Signal Name | Power |
|---------|--------|--------------------|-------|
| - | - | - | |
| GPG6 | GPO | BAT2_CNT2# | |
| - | - | - | |
| GPH0 | OD | PM_CLKRUN# | |
| GPH1 | ALT | - | |
| GPH2 | ALT | - | |
| GPH3 | GPO | BAT_LEARN | |
| GPH4 | GPO | - | |
| GPH5 | GPO | NUM_LED | |
| GPH6 | GPO | CAP_LED | |
| - | - | - | |
| GPI0 | GPI | - | |
| GPI1 | GPI | SUS_PWRGD | |
| GPI2 | GPI | ALL_SYSTEM_PWRGD | |
| GPI3 | GPI | VRM_PWRGD | |
| GPI4 | GPI | PWR_MON | |
| GPI5 | GPI | PD_DET# | |
| GPI6 | GPI | KB_ID0 | |
| GPI7 | GPI | KB_ID1 | |
| GPJ0 | GPO | EC_CLK_EN | |
| GPJ1 | GPO | PM_PWROK | |
| GPJ2 | GPI | UNDOCK#_PD | |
| GPJ3 | - | - | |
| GPJ4 | GPO | BL_DA | |
| GPJ5 | GPO | FAN_DA | |
| GPK0 | GPI | PM_SLP_M# | |
| GPK1 | GPI | SUSPWR_ACK | |
| GPK2 | GPI | PM_SUSC# | |
| GPK3 | GPI | +3VM_PG | |
| GPK4 | GPI | +1.05VM/+3VMCLK_PG | |
| GPK5 | GPI | LAN_WOL_EN | |
| GPL0 | GPI | AC_APR_UC# | |
| GPL1 | GPI | - | |
| GPL2 | GPO | - | |
| GPL3 | GPO | LAN_RST# | |
| GPL4 | GPO | CL_PWROK | |
| GPL5 | GPO | EC_WLAN_PWR | |
| GPL6 | GPO | SLP_M_ON | |
| GPL7 | GPO | S4_STATE_ON | |
| GPK6 | GPO | AC_PRESENT | |
| GPK7 | GPI | PS_CPPE# | |
| - | - | - | |
| - | - | - | |

| PCI Device | IDSEL# | REQ/GNT# | Interrupts |
|-------------|--------|----------|------------|
| CARD READER | AD17 | 0 | A |
| 1394 | AD17 | 0 | B |

| PCIe Device | Bus | PCIe Device | Bus |
|-------------|---------------|-------------|---------------|
| Robson | PE(T/R)(p/n)1 | 3G/TV | PE(T/R)(p/n)4 |
| WLAN | PE(T/R)(p/n)2 | UWB | PE(T/R)(p/n)5 |
| NEWCARD | PE(T/R)(p/n)3 | GLAN | PE(T/R)(p/n)6 |

| SM-Bus Device | SM-Bus Address |
|-----------------------------|-----------------|
| Clock Generator | 1101001x (D2) |
| SO-DIMM 0 | 1010000x (A0) |
| SO-DIMM 1 | 1010001x (A2) |
| CPU Thermal Sensor(MAX6619) | 1001100x (98) |

<Variant Name>

| | | |
|---|--------------------|-------------------------------|
|  | | Title : System Setting |
| ASUSTek Computer INC. NB1 | | Engineer: Alex & Bruce |
| Size | Project Name | Rev |
| Custom | K401J/K501J | 1.1 |
| Date: Monday, March 09, 2009 | Sheet | 2 of 96 |

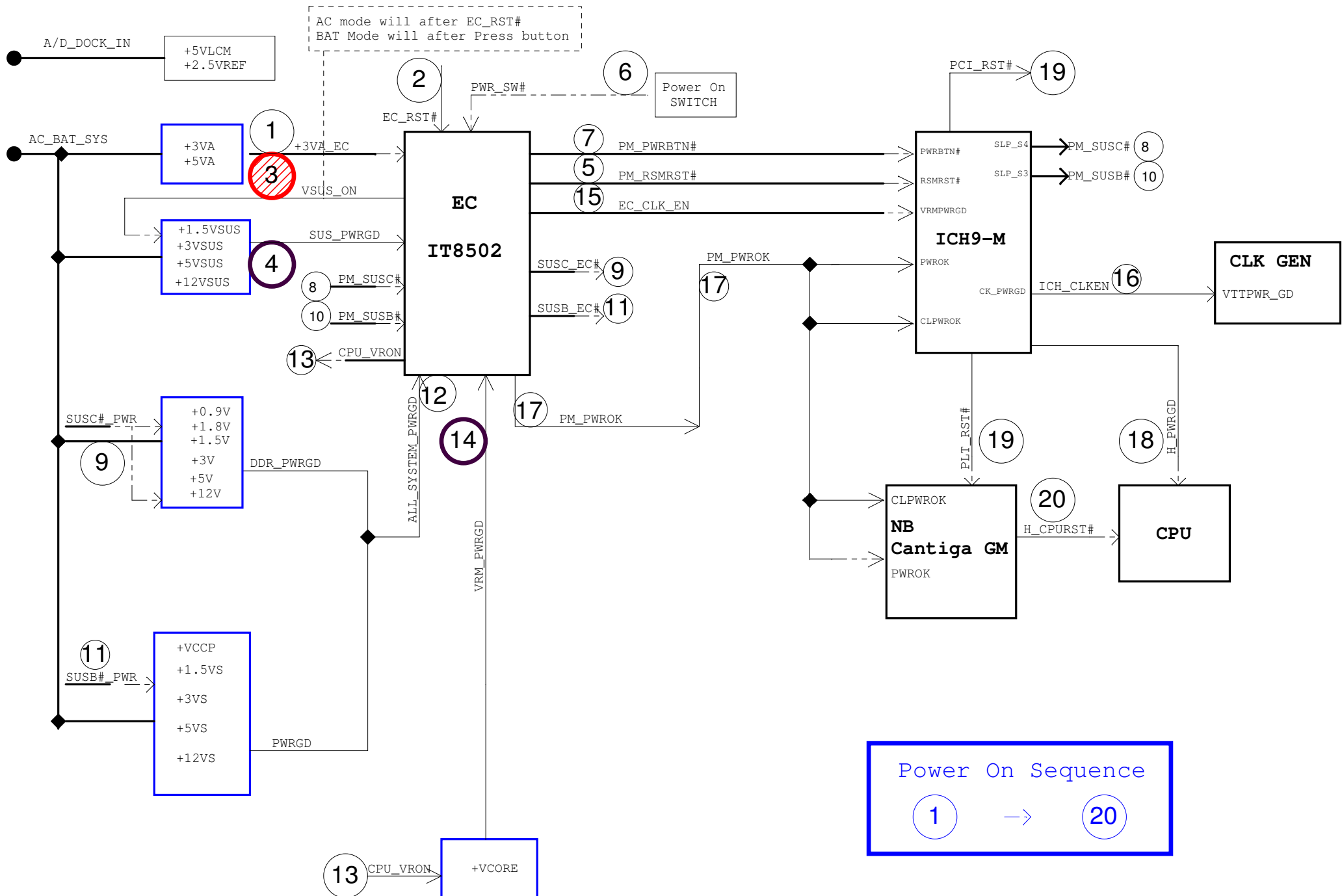

+VCCP -VCCP 5,7,8,9,11,12,15,18,39,42,82

add test point

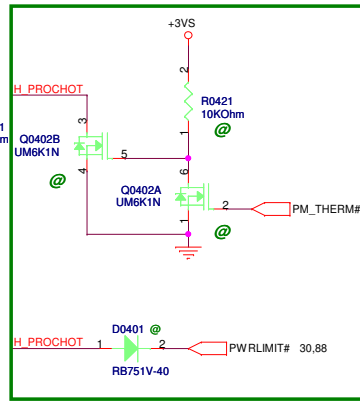
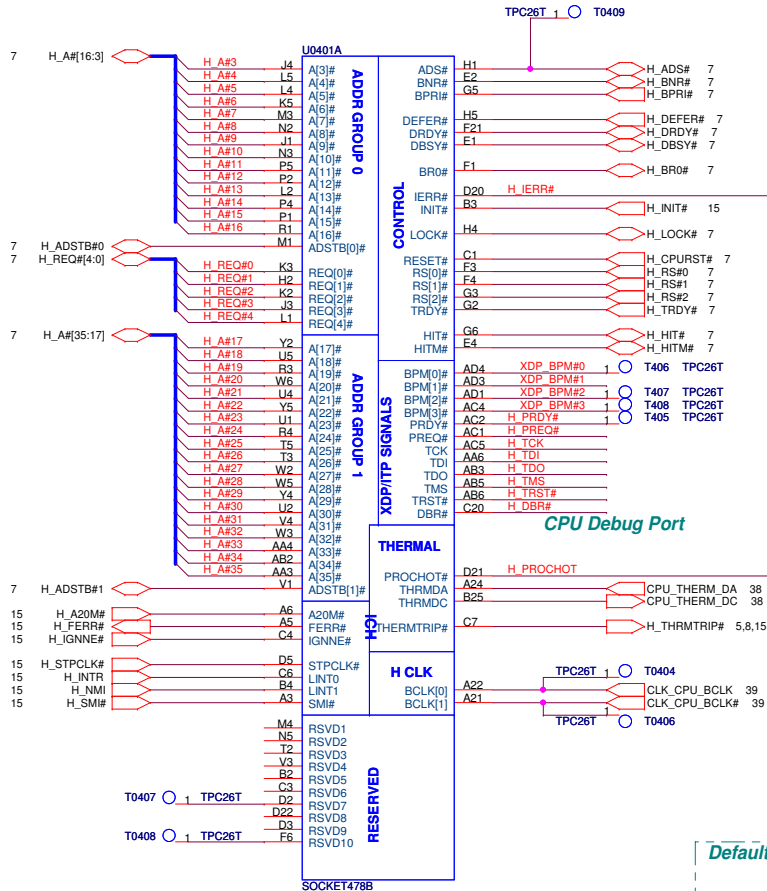

AGTL+ I/O Voltage Reference

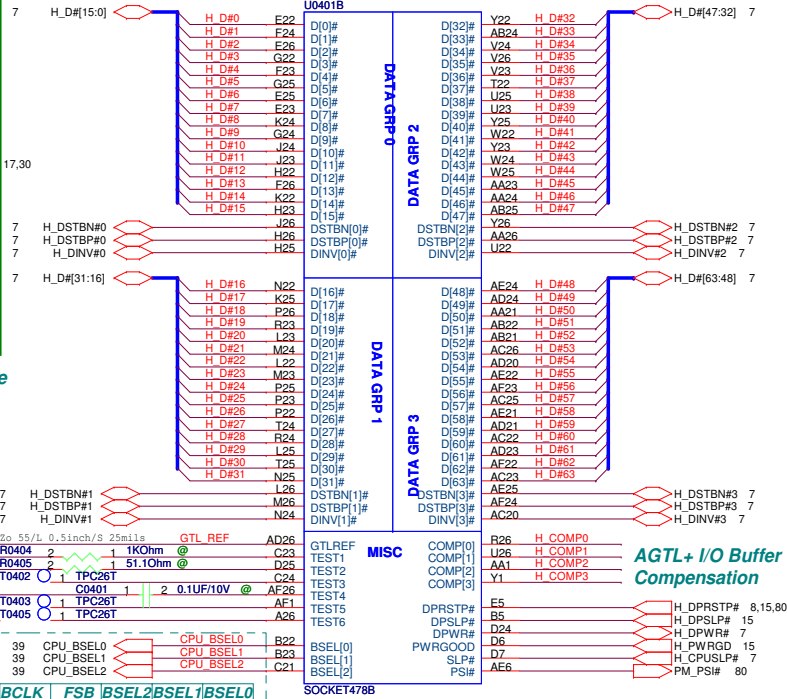
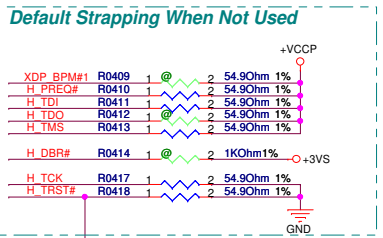
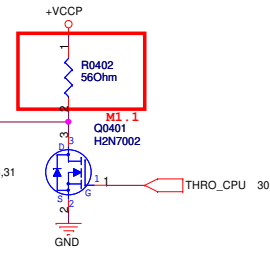

| BCLK | FSB | BSEL2 | BSEL1 | BSEL0 |
|------|------|-------|-------|-------|
| 166 | 667 | L | H | H |
| 200 | 800 | L | H | L |
| 266 | 1066 | L | L | L |

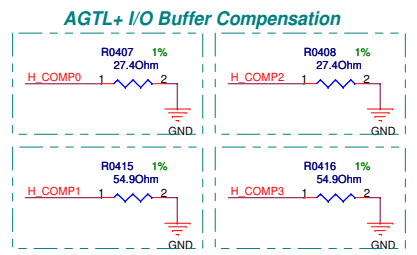

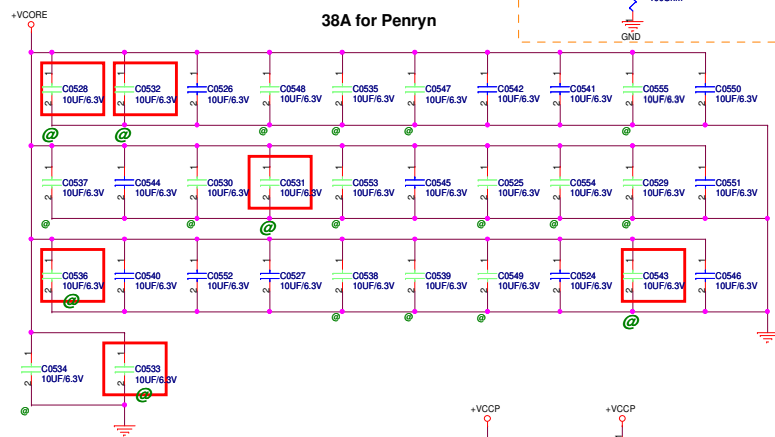
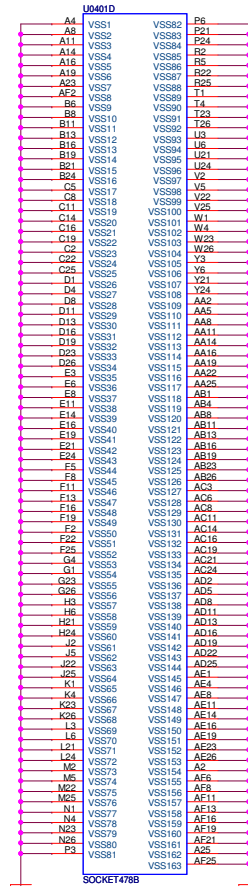
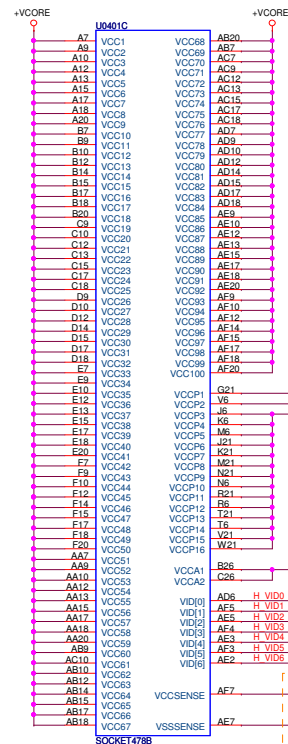

Decoupling guide from Intel

| | | |
|--------|-----------------|----------|
| VCCORE | 22uF/10V r 10uF | * 32pcs |
| | 330uF/2V | * 6pcs |
| VCCP | 0.1uF | * 6pcs |
| | 150uF | * 1pcs ? |
| | 10uF | * 1pcs ? |

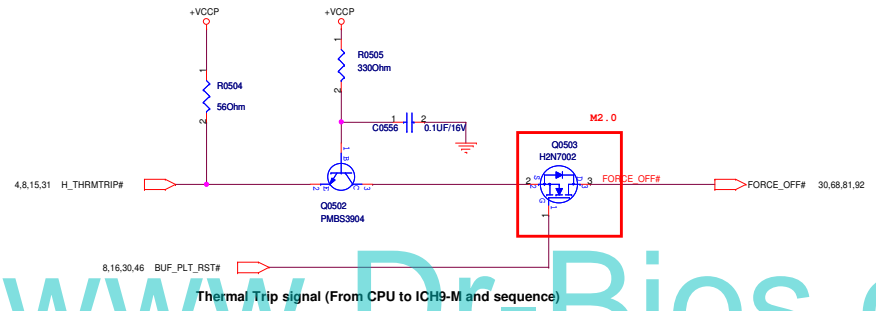

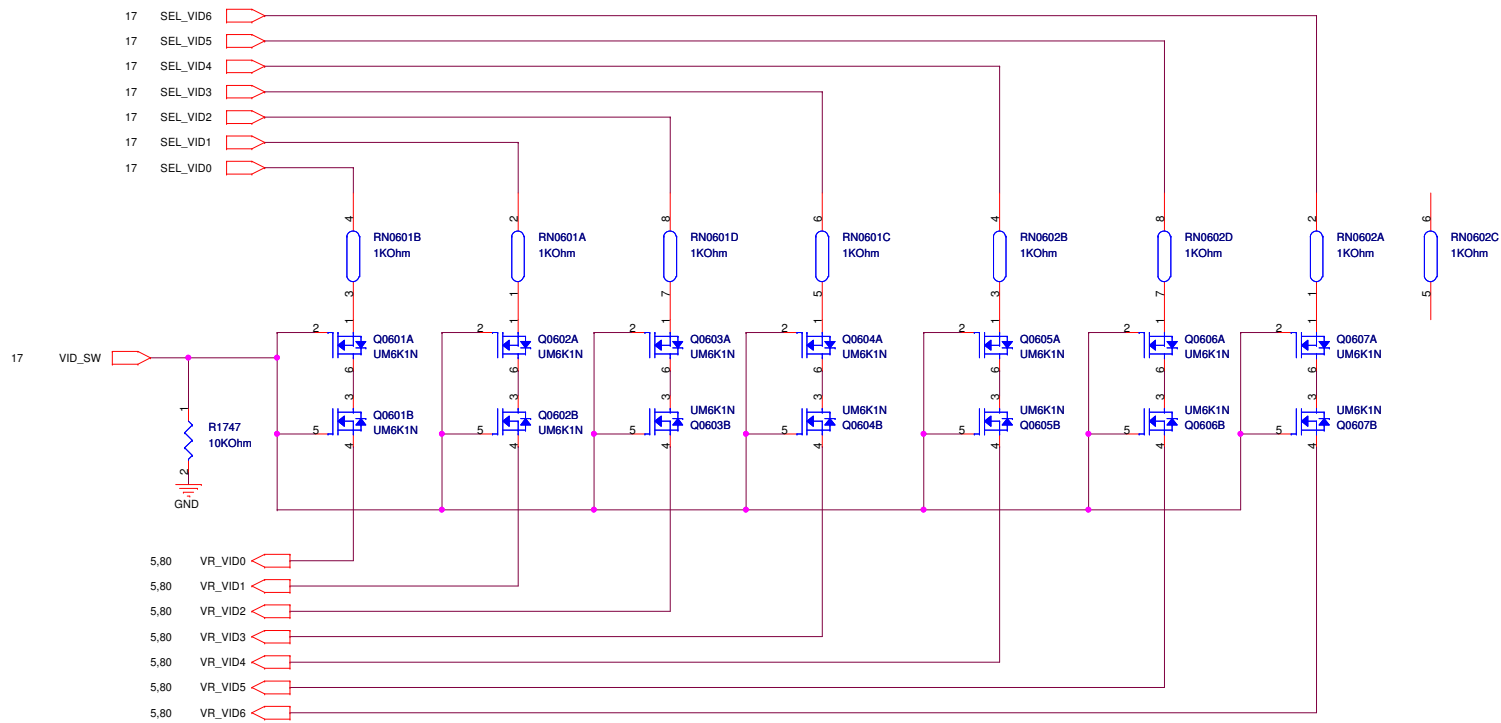

www.Dr-Bios.com

RCOMP

For Calibrating the FSB I/O Buffer

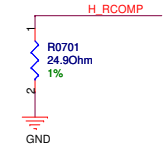

Voltage Swing

For Providing a Reference Voltage to The FSB RCOMP circuits

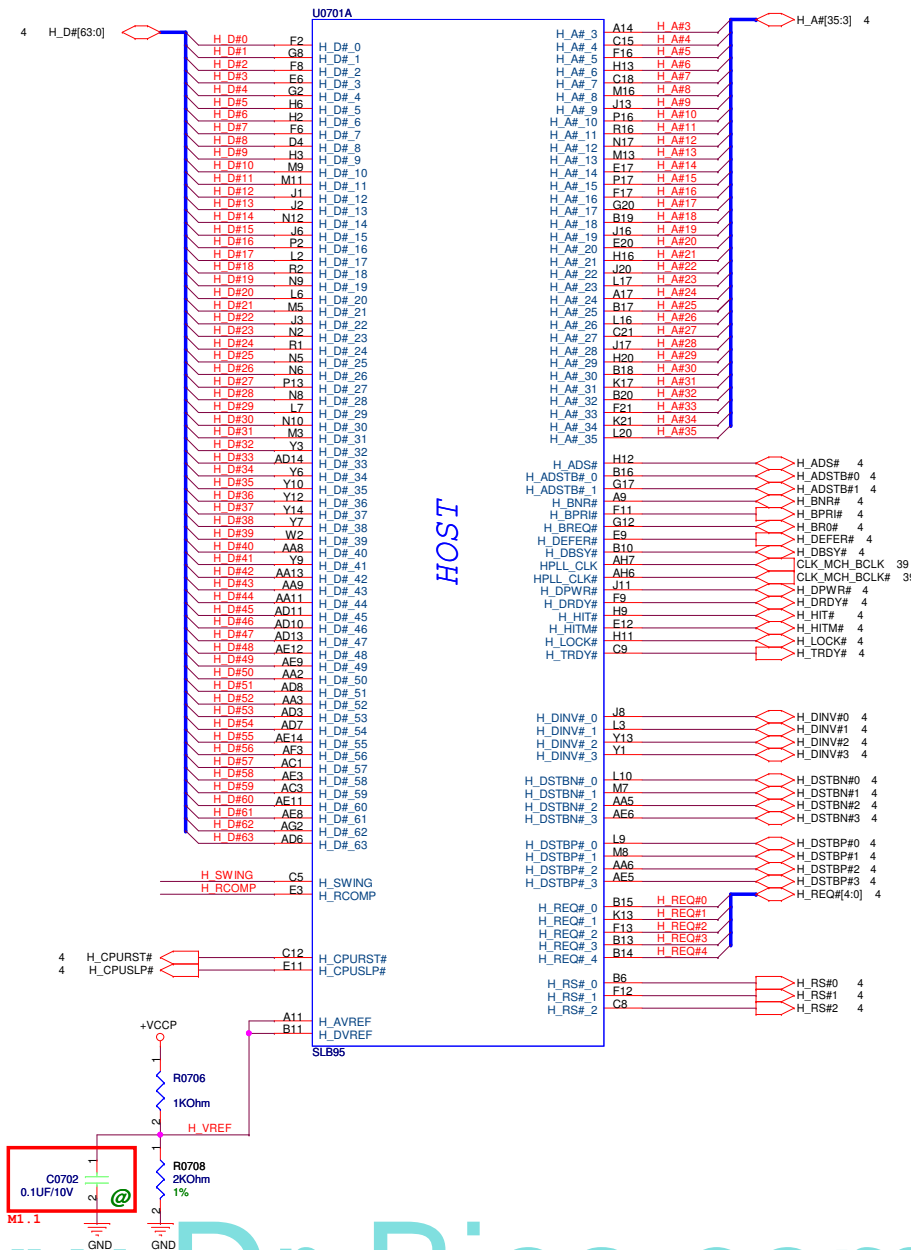
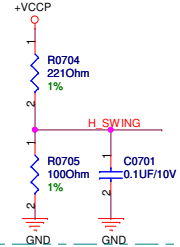

ASUS Title : NB-Cantiga(HOST)
 ASUSTek COMPUTER INC. NB1 Engineer: N/A
 Size Project Name
 Custom K40IJ/K50IJ
 Date: Monday, March 09, 2009 Sheet 7 of 96
 Rev 1.1

GMCH Strapping

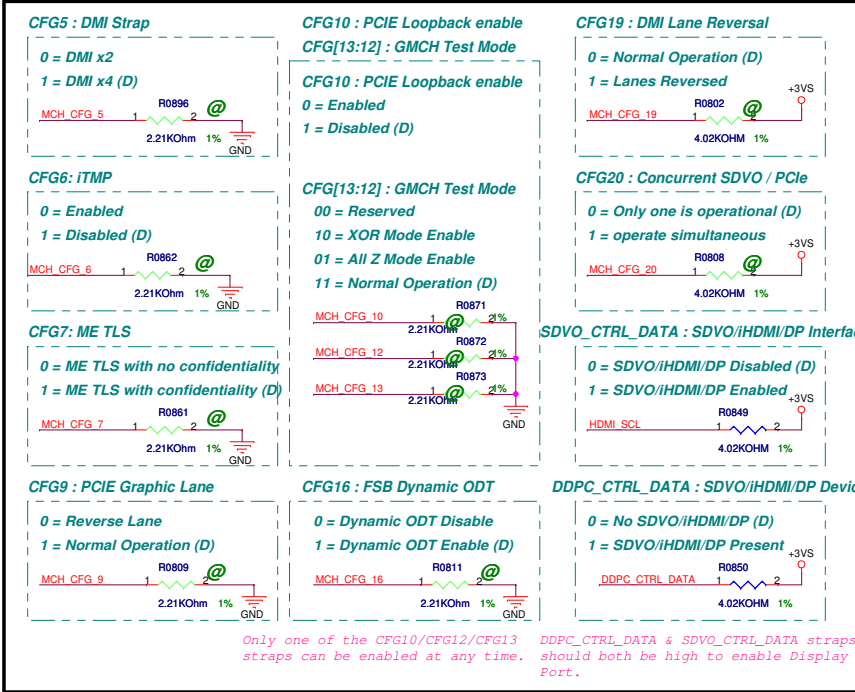

Only one of the CFG10/CFG12/CFG13 DDPC_CTRL_DATA & SDVO_CTRL_DATA straps should both be high to enable Display Port.

| BCLK | FSB | BSEL2 | BSEL1 | BSEL0 |
|------|------|-------|-------|-------|
| 266 | 1066 | L | L | L |
| 166 | 667 | L | H | H |
| 200 | 800 | L | H | L |

- 39 MCH_BSEL0
- 39 MCH_BSEL1
- 39 MCH_BSEL2
- MCH_CFG_5
- MCH_CFG_6
- MCH_CFG_7
- MCH_CFG_9
- MCH_CFG_10
- MCH_CFG_12
- MCH_CFG_13
- MCH_CFG_16
- MCH_CFG_19
- MCH_CFG_20

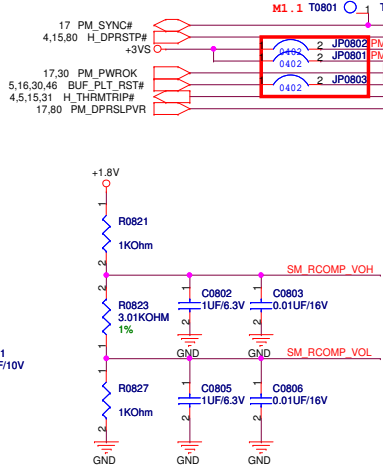
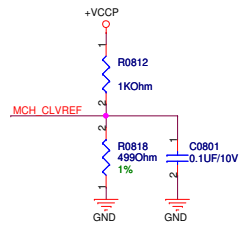
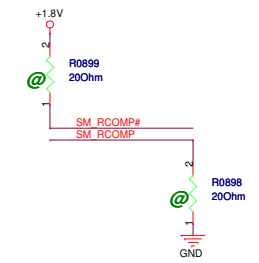

- M36 RSV D1
- N36 RSV D2
- F33 RSV D3
- T33 RSV D4
- AH9 RSV D5
- AH10 RSV D6
- AH12 RSV D7
- AH13 RSV D8
- K12 RSV D9
- AL4 RSV D10
- AK34 ME_JTAG_TCK
- AN35 ME_JTAG_TDI
- AM35 ME_JTAG_TDO
- T24 ME_JTAG_TMS
- B31 RSV D11
- AJ6 VSS
- M1 RSV D13
- AY21 RSV D14
- A47 NC
- BG23 RSV D16
- BF23 RSV D17
- BK34 RSV D18
- BF18 RSV D19
- C0807 0.1uF/16V
- R0830 0ohm
- BG48 NC_1
- BF48 NC_2
- BC48 NC_3
- BC48 NC_3
- BH47 NC_4
- NC_5
- NC_6
- BE47 NC_6
- BH46 NC_7
- NC_8
- BF46 NC_8
- BH44 NC_9
- BH43 NC_10
- NC_11
- BH6 NC_12
- BH5 NC_13
- BC41 NC_14
- BH3 NC_15
- NC_16
- BF3 NC_17
- BH2 NC_18
- NC_19
- BG1 NC_20
- BE2 NC_21
- BF1 NC_22
- BD1 NC_23
- F1 NC_24
- NC_25
- SLB95

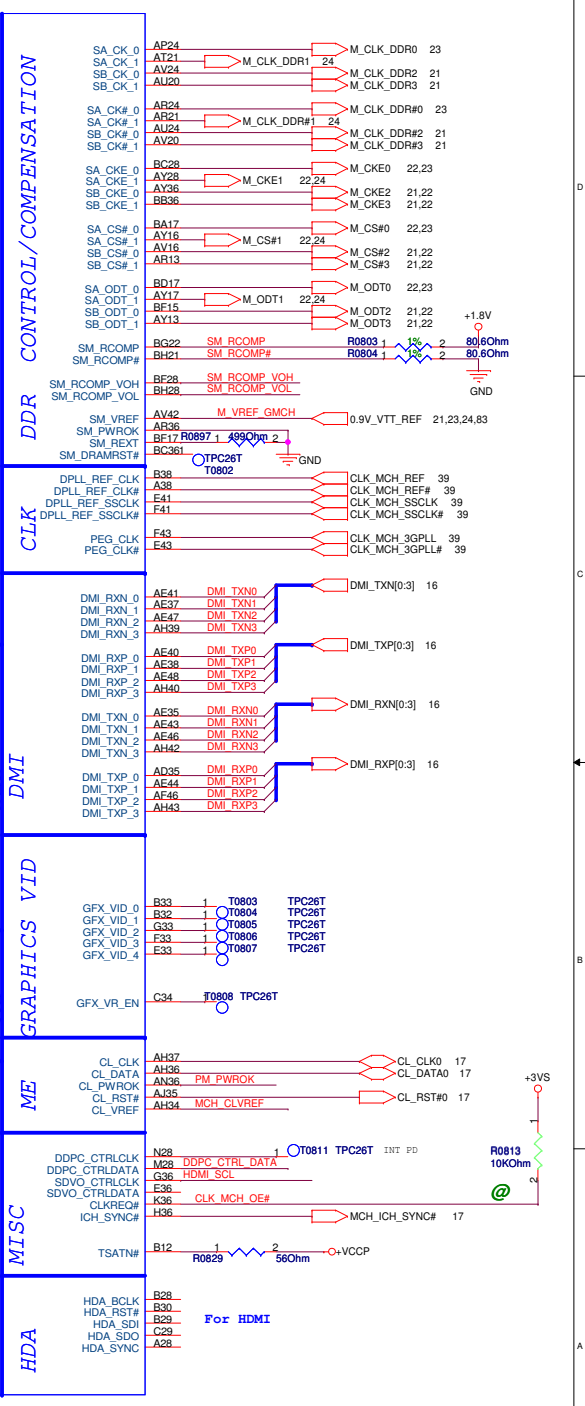

ASUS Title : NB-Cantiga(DMI & CFG)
 ASUSTek COMPUTER INC. NB1 Engineer: N/A
 Size Project Name
 Custom K401J/K501J
 Date: Monday, March 09, 2009 Sheet 8 of 96
 Rev 1.1

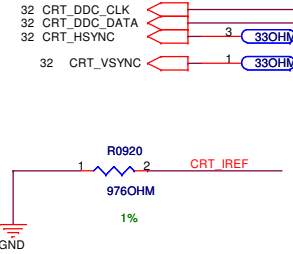
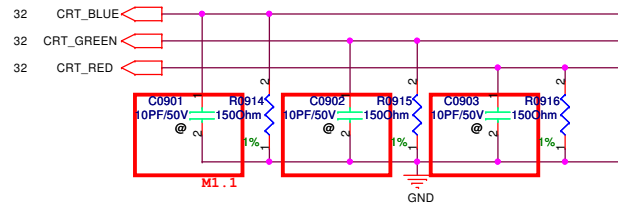
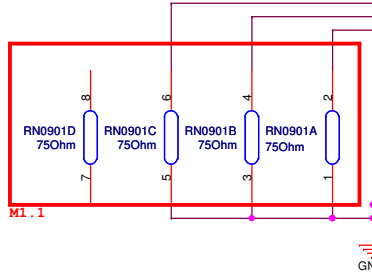
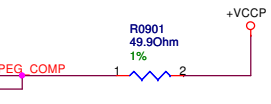
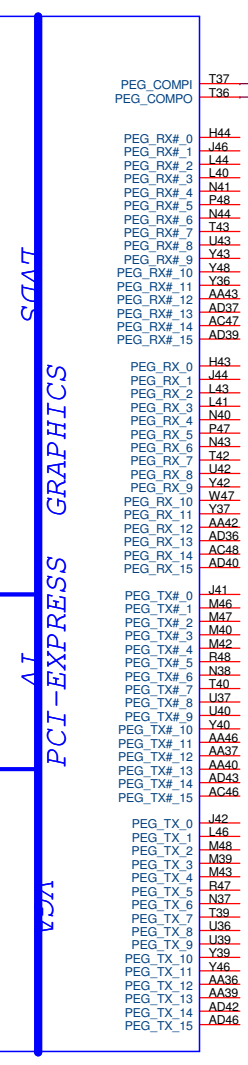
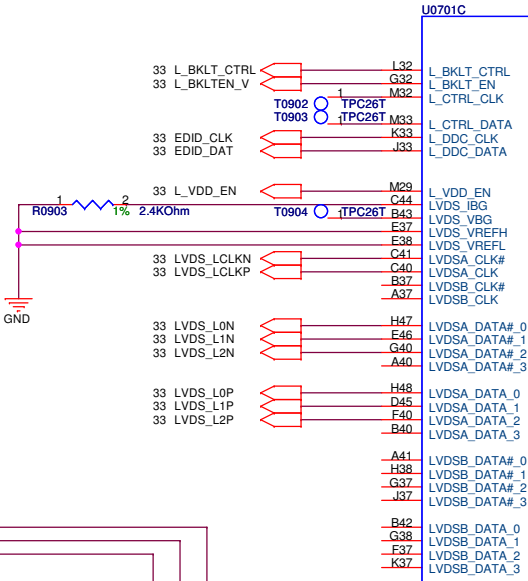
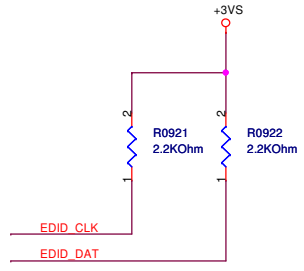

www.Dr-Bios.com

23,24 M_A_DQ[63:0]

| | | |
|----------|------|----------|
| M_A DQ0 | AJ38 | SA DO_0 |
| M_A DQ1 | AL41 | SA DO_1 |
| M_A DQ2 | AN38 | SA DO_2 |
| M_A DQ3 | AM38 | SA DO_3 |
| M_A DQ4 | AJ36 | SA DO_4 |
| M_A DQ5 | AJ40 | SA DO_5 |
| M_A DQ6 | AM44 | SA DO_6 |
| M_A DQ7 | AM42 | SA DO_7 |
| M_A DQ8 | AN43 | SA DO_8 |
| M_A DQ9 | AN44 | SA DO_9 |
| M_A DQ10 | AU40 | SA DO_10 |
| M_A DQ11 | AT38 | SA DO_11 |
| M_A DQ12 | AN41 | SA DO_12 |
| M_A DQ13 | AN39 | SA DO_13 |
| M_A DQ14 | AU44 | SA DO_14 |
| M_A DQ15 | AU42 | SA DO_15 |
| M_A DQ16 | AV39 | SA DO_16 |
| M_A DQ17 | AY44 | SA DO_17 |
| M_A DQ18 | BA40 | SA DO_18 |
| M_A DQ19 | BD43 | SA DO_19 |
| M_A DQ20 | AV41 | SA DO_20 |
| M_A DQ21 | AY43 | SA DO_21 |
| M_A DQ22 | BB41 | SA DO_22 |
| M_A DQ23 | BC40 | SA DO_23 |
| M_A DQ24 | AV37 | SA DO_24 |
| M_A DQ25 | AV37 | SA DO_25 |
| M_A DQ26 | AV37 | SA DO_26 |
| M_A DQ27 | AT36 | SA DO_27 |
| M_A DQ28 | AY38 | SA DO_28 |
| M_A DQ29 | BB38 | SA DO_29 |
| M_A DQ30 | AV36 | SA DO_30 |
| M_A DQ31 | AV36 | SA DO_31 |
| M_A DQ32 | BD13 | SA DO_32 |
| M_A DQ33 | AL11 | SA DO_33 |
| M_A DQ34 | BC11 | SA DO_34 |
| M_A DQ35 | BA12 | SA DO_35 |
| M_A DQ36 | AU13 | SA DO_36 |
| M_A DQ37 | AV13 | SA DO_37 |
| M_A DQ38 | BD12 | SA DO_38 |
| M_A DQ39 | BC12 | SA DO_39 |
| M_A DQ40 | BB9 | SA DO_40 |
| M_A DQ41 | BA9 | SA DO_41 |
| M_A DQ42 | AU10 | SA DO_42 |
| M_A DQ43 | AV9 | SA DO_43 |
| M_A DQ44 | BA11 | SA DO_44 |
| M_A DQ45 | BD9 | SA DO_45 |
| M_A DQ46 | AY8 | SA DO_46 |
| M_A DQ47 | BA6 | SA DO_47 |
| M_A DQ48 | AV5 | SA DO_48 |
| M_A DQ49 | AV7 | SA DO_49 |
| M_A DQ50 | AT9 | SA DO_50 |
| M_A DQ51 | AN8 | SA DO_51 |
| M_A DQ52 | AL5 | SA DO_52 |
| M_A DQ53 | AU6 | SA DO_53 |
| M_A DQ54 | AT5 | SA DO_54 |
| M_A DQ55 | AN10 | SA DO_55 |
| M_A DQ56 | AM11 | SA DO_56 |
| M_A DQ57 | AM5 | SA DO_57 |
| M_A DQ58 | AJ9 | SA DO_58 |
| M_A DQ59 | AJ8 | SA DO_59 |
| M_A DQ60 | AN12 | SA DO_60 |
| M_A DQ61 | AM13 | SA DO_61 |
| M_A DQ62 | AJ11 | SA DO_62 |
| M_A DQ63 | AJ12 | SA DO_63 |

DDR SYSTEM MEMORY A

| | | | |
|-----------|------|-----------|----------------------|
| SA_BS_0 | BD21 | M_A_BS0 | 22,23,24 |
| SA_BS_1 | BG18 | M_A_BS1 | 22,23,24 |
| SA_BS_2 | AT25 | M_A_BS2 | 22,23,24 |
| SA_RAS# | BB20 | M_A_RAS# | 22,23,24 |
| SA_CAS# | BD20 | M_A_CAS# | 22,23,24 |
| SA_WE# | AY20 | M_A_WE# | 22,23,24 |
| SA_DM_0 | AM37 | M_A_DM0 | M_A_DM[7:0] 23,24 |
| SA_DM_1 | AT41 | M_A_DM1 | |
| SA_DM_2 | AY41 | M_A_DM2 | |
| SA_DM_3 | AU39 | M_A_DM3 | |
| SA_DM_4 | BB12 | M_A_DM4 | |
| SA_DM_5 | AY6 | M_A_DM5 | |
| SA_DM_6 | AT7 | M_A_DM6 | |
| SA_DM_7 | AJ5 | M_A_DM7 | |
| SA_DQS_0 | AJ44 | M_A_DQS0 | M_A_DQS[7:0] 23,24 |
| SA_DQS_1 | AT44 | M_A_DQS1 | |
| SA_DQS_2 | BA43 | M_A_DQS2 | |
| SA_DQS_3 | BC37 | M_A_DQS3 | |
| SA_DQS_4 | AW12 | M_A_DQS4 | |
| SA_DQS_5 | BC4 | M_A_DQS5 | |
| SA_DQS_6 | AL8 | M_A_DQS6 | |
| SA_DQS_7 | AM7 | M_A_DQS7 | |
| SA_DQS#_0 | AJ43 | M_A_DQS#0 | M_A_DQS#[7:0] 23,24 |
| SA_DQS#_1 | AT43 | M_A_DQS#1 | |
| SA_DQS#_2 | BA44 | M_A_DQS#2 | |
| SA_DQS#_3 | BD37 | M_A_DQS#3 | |
| SA_DQS#_4 | AY12 | M_A_DQS#4 | |
| SA_DQS#_5 | BD8 | M_A_DQS#5 | |
| SA_DQS#_6 | AJ9 | M_A_DQS#6 | |
| SA_DQS#_7 | AM8 | M_A_DQS#7 | |
| SA_MA_0 | BA21 | M_A_A0 | M_A_A[13:0] 22,23,24 |
| SA_MA_1 | BC24 | M_A_A1 | |
| SA_MA_2 | BG24 | M_A_A2 | |
| SA_MA_3 | BH24 | M_A_A3 | |
| SA_MA_4 | BG25 | M_A_A4 | |
| SA_MA_5 | BA24 | M_A_A5 | |
| SA_MA_6 | BD24 | M_A_A6 | |
| SA_MA_7 | BG27 | M_A_A7 | |
| SA_MA_8 | BE25 | M_A_A8 | |
| SA_MA_9 | AW24 | M_A_A9 | |
| SA_MA_10 | BC21 | M_A_A10 | |
| SA_MA_11 | BG26 | M_A_A11 | |
| SA_MA_12 | BH26 | M_A_A12 | |
| SA_MA_13 | BH17 | M_A_A13 | |
| SA_MA_14 | AY25 | | |

SLB95

21 M_B_DQ[63:0]

| | | |
|----------|------|----------|
| M_B DQ0 | AK47 | SB DO_0 |
| M_B DQ1 | AH46 | SB DO_1 |
| M_B DQ2 | AP47 | SB DO_2 |
| M_B DQ3 | AP46 | SB DO_3 |
| M_B DQ4 | AJ46 | SB DO_4 |
| M_B DQ5 | AM48 | SB DO_5 |
| M_B DQ6 | AM48 | SB DO_6 |
| M_B DQ7 | AP48 | SB DO_7 |
| M_B DQ8 | AU47 | SB DO_8 |
| M_B DQ9 | AU46 | SB DO_9 |
| M_B DQ10 | BA48 | SB DO_10 |
| M_B DQ11 | AY48 | SB DO_11 |
| M_B DQ12 | AT47 | SB DO_12 |
| M_B DQ13 | AR47 | SB DO_13 |
| M_B DQ14 | BA47 | SB DO_14 |
| M_B DQ15 | BC47 | SB DO_15 |
| M_B DQ16 | BC46 | SB DO_16 |
| M_B DQ17 | BC44 | SB DO_17 |
| M_B DQ18 | BG43 | SB DO_18 |
| M_B DQ19 | BF43 | SB DO_19 |
| M_B DQ20 | BE45 | SB DO_20 |
| M_B DQ21 | BC41 | SB DO_21 |
| M_B DQ22 | BF40 | SB DO_22 |
| M_B DQ23 | BE41 | SB DO_23 |
| M_B DQ24 | BG38 | SB DO_24 |
| M_B DQ25 | BF38 | SB DO_25 |
| M_B DQ26 | BH35 | SB DO_26 |
| M_B DQ27 | BG35 | SB DO_27 |
| M_B DQ28 | BH40 | SB DO_28 |
| M_B DQ29 | BG39 | SB DO_29 |
| M_B DQ30 | BG34 | SB DO_30 |
| M_B DQ31 | BH34 | SB DO_31 |
| M_B DQ32 | BH14 | SB DO_32 |
| M_B DQ33 | BG12 | SB DO_33 |
| M_B DQ34 | BH11 | SB DO_34 |
| M_B DQ35 | BG8 | SB DO_35 |
| M_B DQ36 | BH12 | SB DO_36 |
| M_B DQ37 | BE11 | SB DO_37 |
| M_B DQ38 | BE8 | SB DO_38 |
| M_B DQ39 | BG7 | SB DO_39 |
| M_B DQ40 | BC5 | SB DO_40 |
| M_B DQ41 | BC6 | SB DO_41 |
| M_B DQ42 | AY3 | SB DO_42 |
| M_B DQ43 | AY1 | SB DO_43 |
| M_B DQ44 | BE6 | SB DO_44 |
| M_B DQ45 | BF5 | SB DO_45 |
| M_B DQ46 | BA1 | SB DO_46 |
| M_B DQ47 | BD3 | SB DO_47 |
| M_B DQ48 | AV2 | SB DO_48 |
| M_B DQ49 | AU3 | SB DO_49 |
| M_B DQ50 | AR3 | SB DO_50 |
| M_B DQ51 | AN2 | SB DO_51 |
| M_B DQ52 | AY2 | SB DO_52 |
| M_B DQ53 | AV1 | SB DO_53 |
| M_B DQ54 | AP3 | SB DO_54 |
| M_B DQ55 | AR1 | SB DO_55 |
| M_B DQ56 | AL1 | SB DO_56 |
| M_B DQ57 | AL2 | SB DO_57 |
| M_B DQ58 | AJ1 | SB DO_58 |
| M_B DQ59 | AH1 | SB DO_59 |
| M_B DQ60 | AM2 | SB DO_60 |
| M_B DQ61 | AM3 | SB DO_61 |
| M_B DQ62 | AH3 | SB DO_62 |
| M_B DQ63 | AJ3 | SB DO_63 |

DDR SYSTEM MEMORY B

| | | | |
|-----------|------|-----------|-------------------|
| SB_BS_0 | BC16 | M_B_BS0 | 21,22 |
| SB_BS_1 | BB17 | M_B_BS1 | 21,22 |
| SB_BS_2 | BB33 | M_B_BS2 | 21,22 |
| SB_RAS# | AU17 | M_B_RAS# | 21,22 |
| SB_CAS# | BG16 | M_B_CAS# | 21,22 |
| SB_WE# | BE14 | M_B_WE# | 21,22 |
| SB_DM_0 | AM47 | M_B_DM0 | M_B_DM[7:0] 21 |
| SB_DM_1 | AY47 | M_B_DM1 | |
| SB_DM_2 | BD40 | M_B_DM2 | |
| SB_DM_3 | BF35 | M_B_DM3 | |
| SB_DM_4 | BG11 | M_B_DM4 | |
| SB_DM_5 | BA3 | M_B_DM5 | |
| SB_DM_6 | AP1 | M_B_DM6 | |
| SB_DM_7 | AK2 | M_B_DM7 | |
| SB_DQS_0 | AL47 | M_B_DQS0 | M_B_DQS[7:0] 21 |
| SB_DQS_1 | AV48 | M_B_DQS1 | |
| SB_DQS_2 | BC41 | M_B_DQS2 | |
| SB_DQS_3 | BG37 | M_B_DQS3 | |
| SB_DQS_4 | BH9 | M_B_DQS4 | |
| SB_DQS_5 | BB2 | M_B_DQS5 | |
| SB_DQS_6 | AU1 | M_B_DQS6 | |
| SB_DQS_7 | AN6 | M_B_DQS7 | |
| SB_DQS#_0 | AL46 | M_B_DQS#0 | M_B_DQS#[7:0] 21 |
| SB_DQS#_1 | AV47 | M_B_DQS#1 | |
| SB_DQS#_2 | BH41 | M_B_DQS#2 | |
| SB_DQS#_3 | BH37 | M_B_DQS#3 | |
| SB_DQS#_4 | BG9 | M_B_DQS#4 | |
| SB_DQS#_5 | BC2 | M_B_DQS#5 | |
| SB_DQS#_6 | AT2 | M_B_DQS#6 | |
| SB_DQS#_7 | AN5 | M_B_DQS#7 | |
| SB_MA_0 | AV17 | M_B_A0 | M_B_A[14:0] 21,22 |
| SB_MA_1 | BA25 | M_B_A1 | |
| SB_MA_2 | BC25 | M_B_A2 | |
| SB_MA_3 | AU25 | M_B_A3 | |
| SB_MA_4 | AW25 | M_B_A4 | |
| SB_MA_5 | BE28 | M_B_A5 | |
| SB_MA_6 | AU28 | M_B_A6 | |
| SB_MA_7 | AW28 | M_B_A7 | |
| SB_MA_8 | AT33 | M_B_A8 | |
| SB_MA_9 | BD33 | M_B_A9 | |
| SB_MA_10 | BB16 | M_B_A10 | |
| SB_MA_11 | AW33 | M_B_A11 | |
| SB_MA_12 | AY33 | M_B_A12 | |
| SB_MA_13 | BH15 | M_B_A13 | |
| SB_MA_14 | AU33 | M_B_A14 | |

SLB95

<Variant Name>

ASUS Title : NB-Cantiga(DDR2)

ASUSTeK COMPUTER INC. NB1 Engineer: N/A

| | | |
|--------|------------------------|----------------|
| Size | Project Name | Rev |
| Custom | K401J/K501J | 1.1 |
| Date: | Monday, March 09, 2009 | Sheet 10 of 96 |

Max : 3000mA(DDR2)

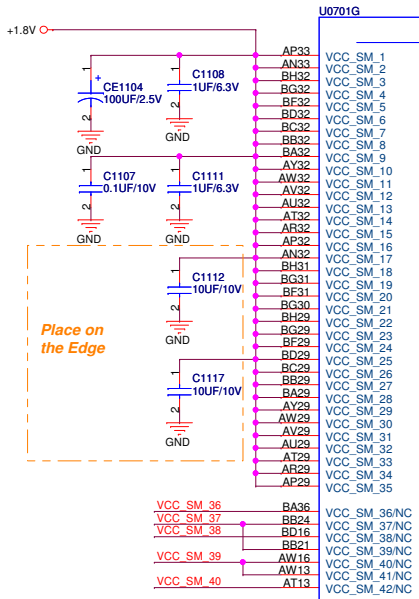

VCC SM POWER

Max : 8700mA(Graphic Core)

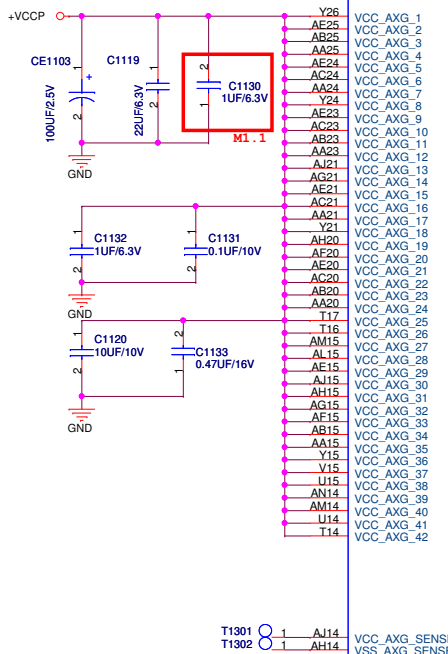

VCC GFX

VCC GFX NCTF

VCC SM LF

+VCCP (Graph Core)

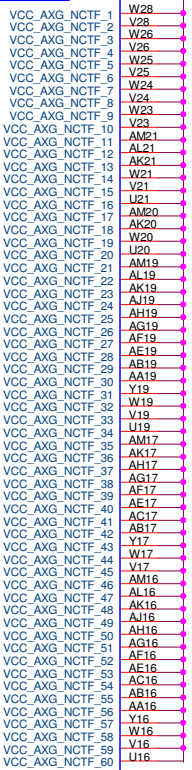

Max : 2900mA(Core)

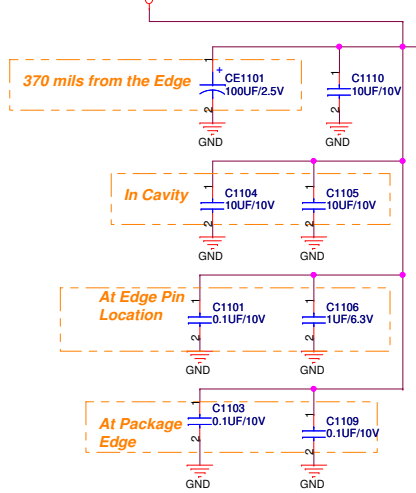

VCC CORE

POWER

VCC NCTF

VCC NCTF

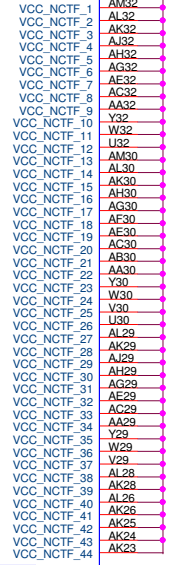

Route VCC_AGX_SENSE and VSS_AGX_SENSE differentially.

M1.1 0.22UF change to 1UF

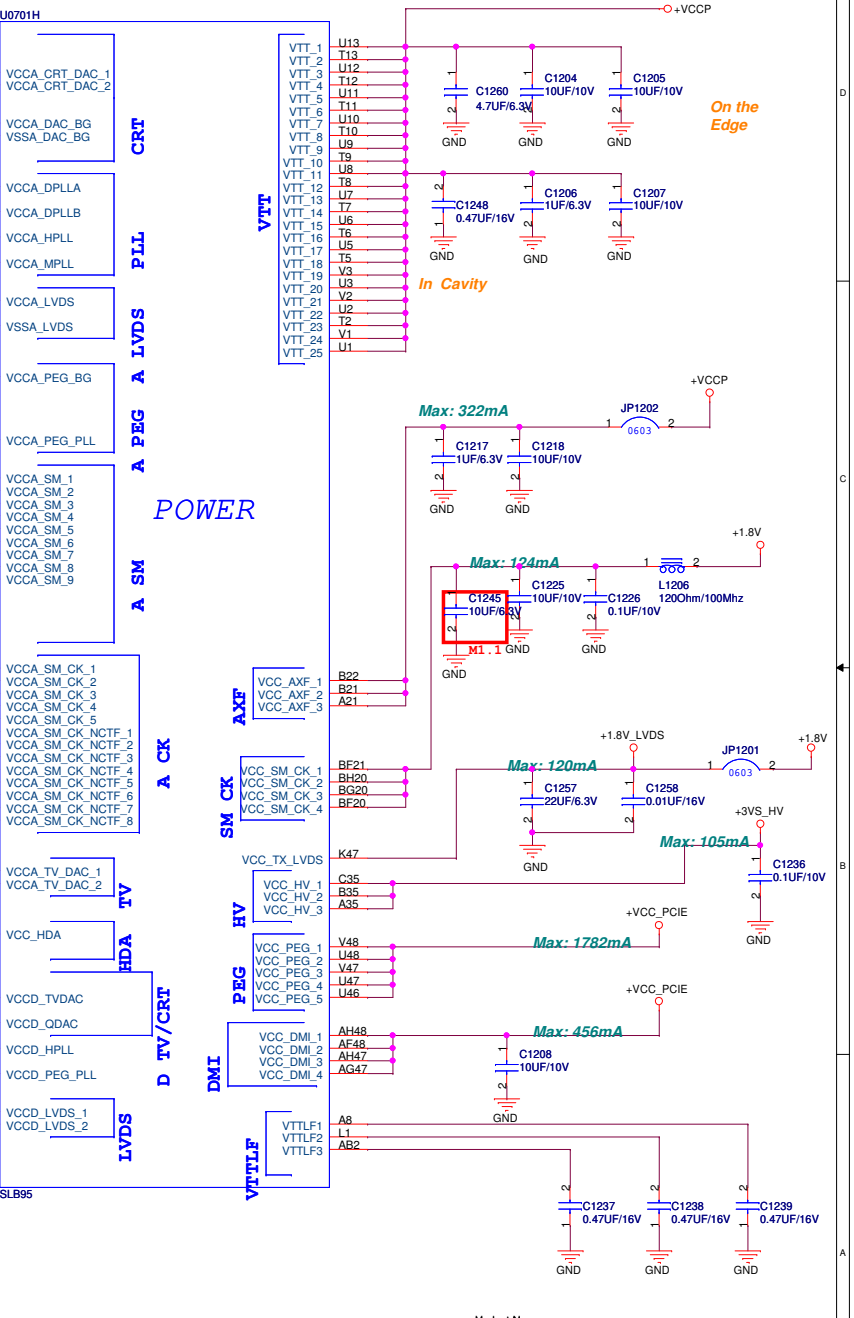
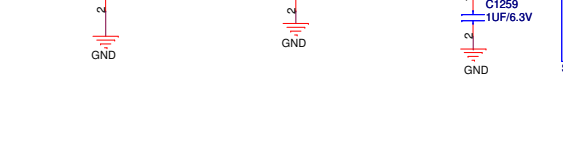
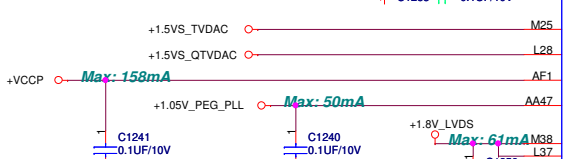
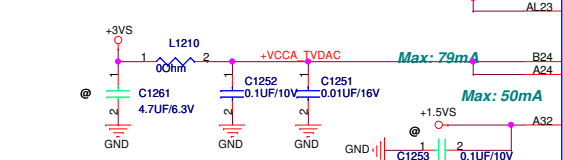
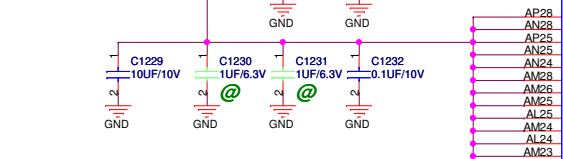
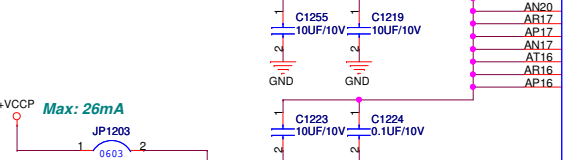
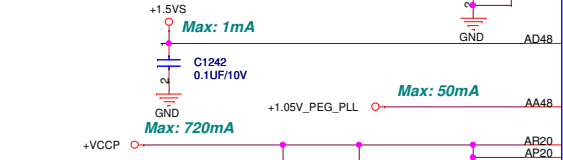
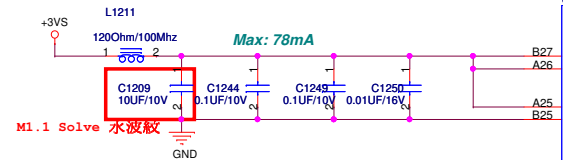
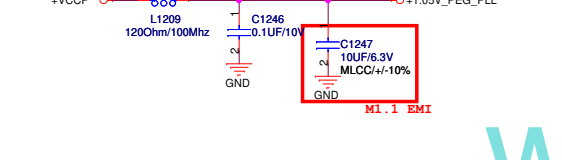
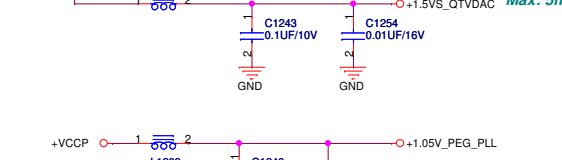
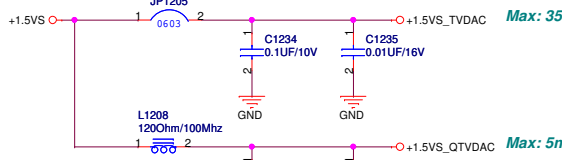
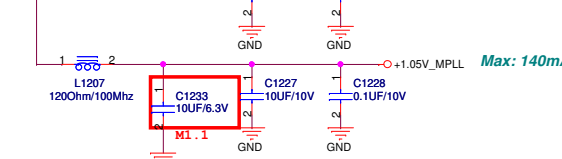
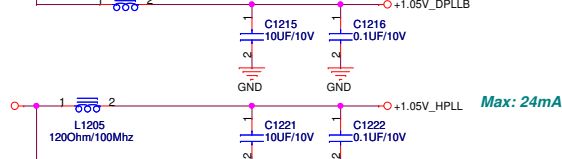
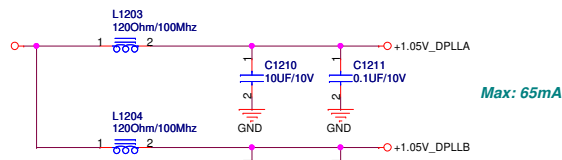
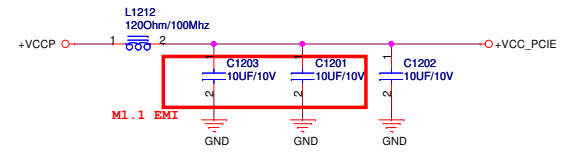

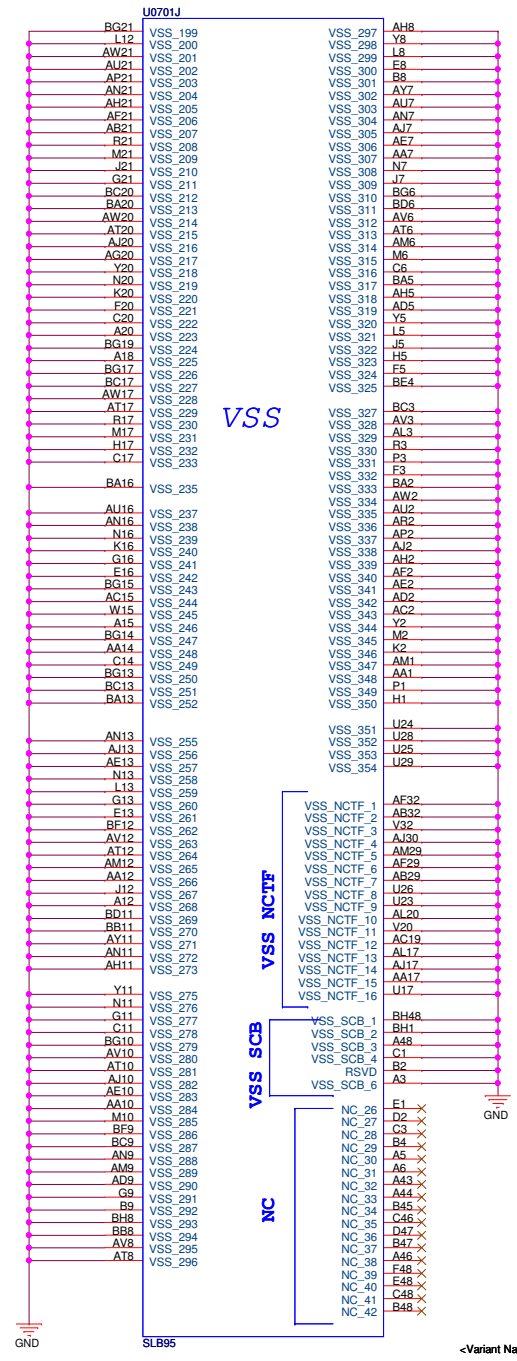
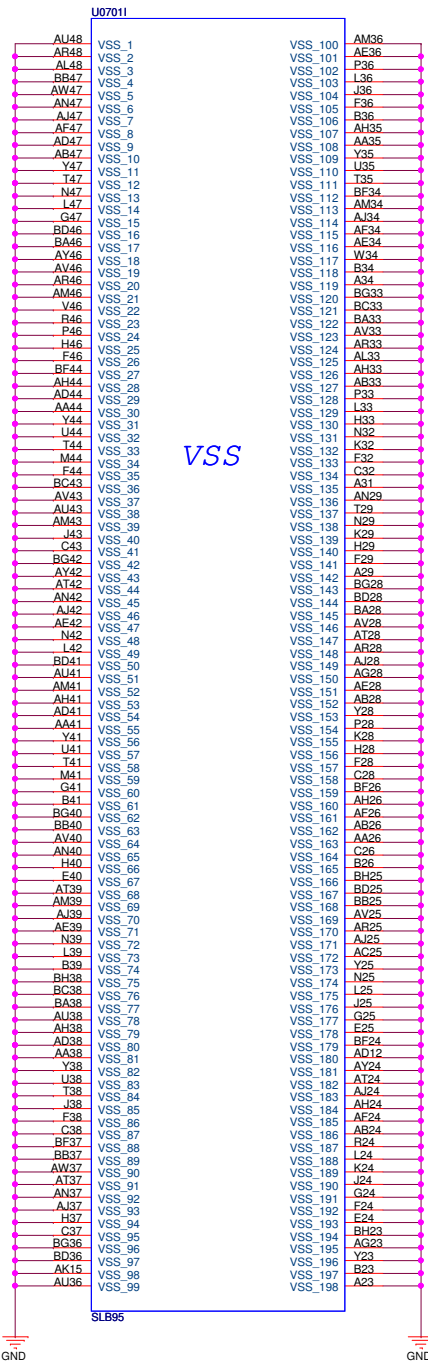

www.Dr-Bios.com

<Variant Name>

| | | |
|---|--------------|------------------------------------|
|  | | Title : Schematic page name |
| ASUSTeK COMPUTER INC | | Engineer: N/A |
| Size | Project Name | Rev |
| C | K40LJ/K50LJ | 1.1 |
| Date: Monday, March 09, 2009 | | Sheet 14 of 95 |

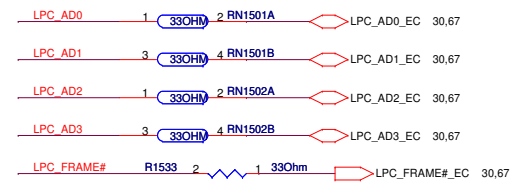
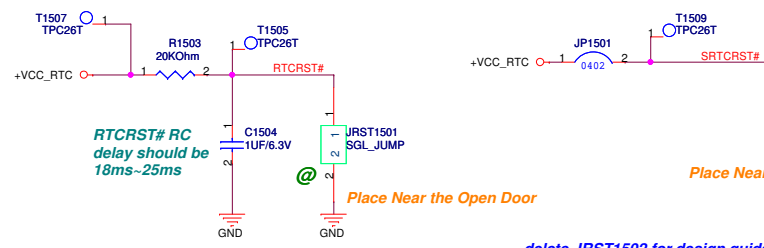
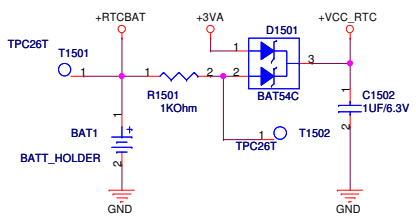

delete JRST1502 for design guide recommendation.

ICH_INTVRMEN (VCCSUS1_05, VCCSUS1_5, VCCCL1_5)
 Low - Disabled Internal VR (D)
 High - Enable Internal VR (D)
 ICH_LAN100 (VCCLAN1_05, VCCCL1_05)
 Low - Disabled Internal VR (D)
 High - Enable Internal VR (D)

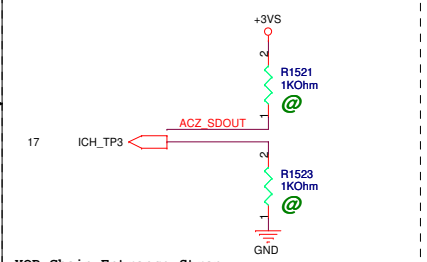

XOR Chain Entrance Strap

| ICH_TP3 | ACZ_SDOUT | Description |
|---------|-----------|----------------------------|
| 0 | 0 | RSVD |
| 1 | 1 | Enter XOR Chain |
| 1 | 0 | Normal Operation (D) |
| 1 | 1 | Set PCIe port config bit 1 |

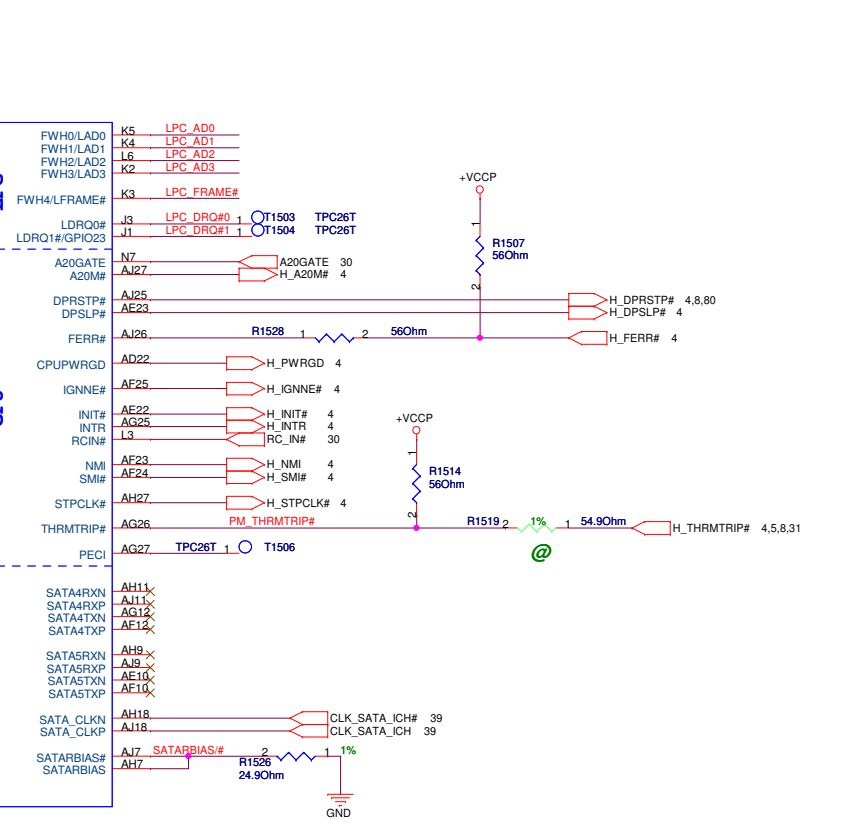
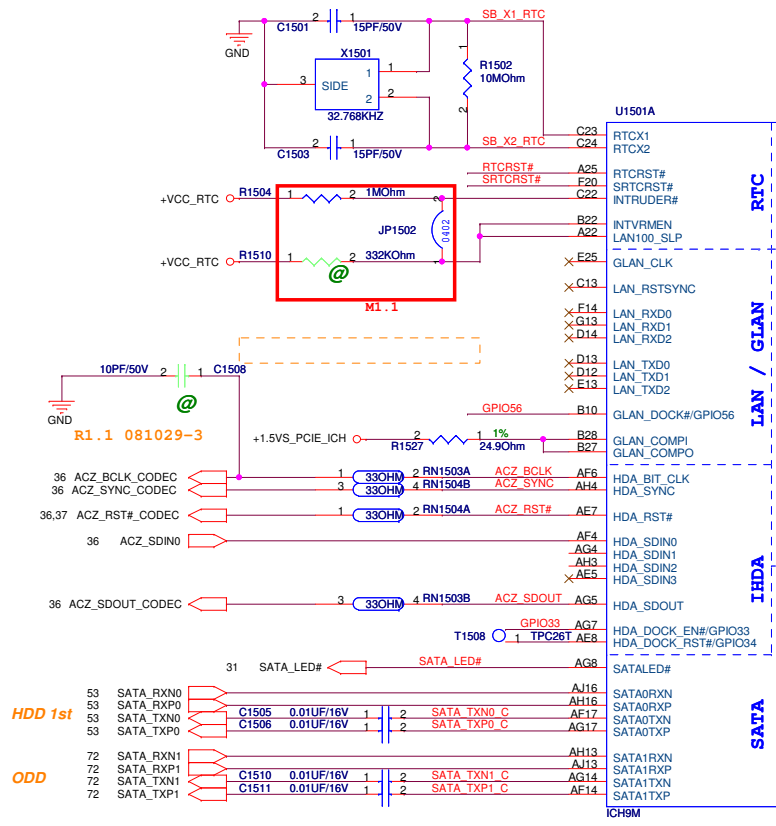
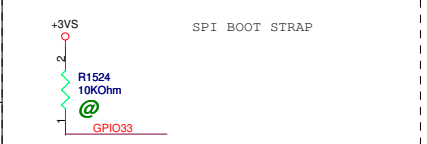

www.Dr-Bios.com

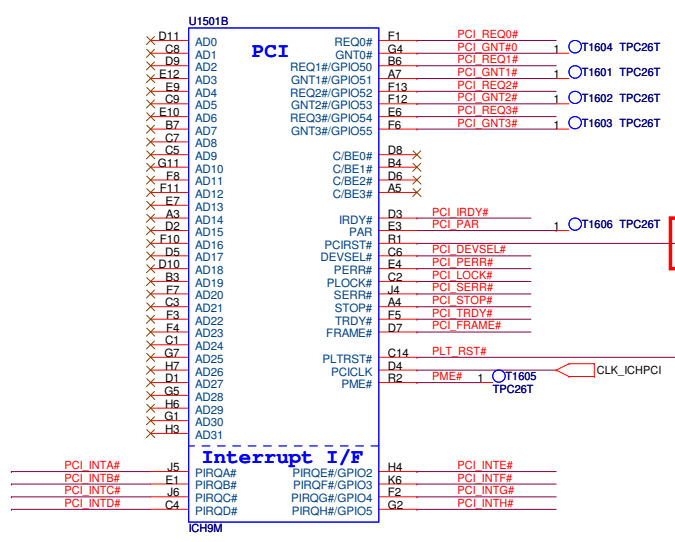

ICH8 Boot BIOS Select

| | GNT#0 | CS#1 |
|-----|-------|------|
| LPC | H | H |
| PCI | H | L |
| SPI | L | H |

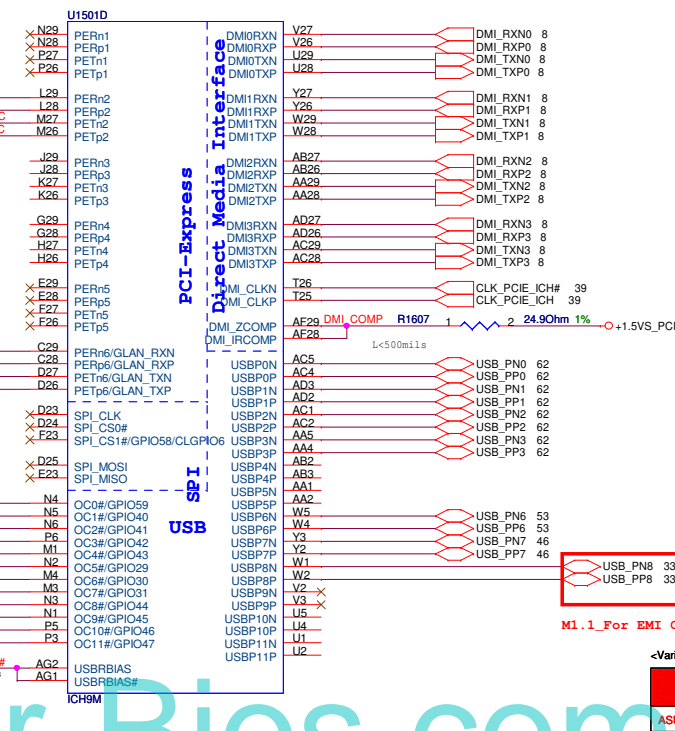
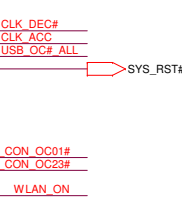
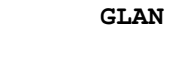
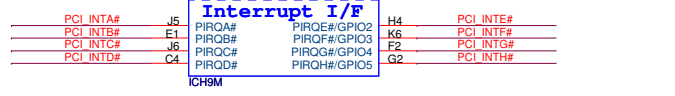
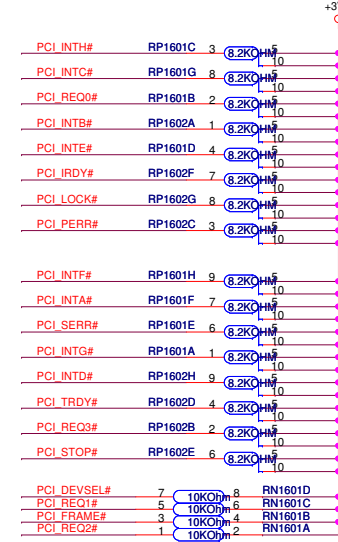
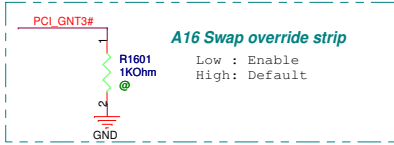

| | |
|--------|------------------|
| USB 0 | USB Conn.(M/B) |
| USB 1 | USB Conn.(M/B) |
| USB 2 | USB Conn.(M/B) |
| USB 3 | USB Conn.(M/B) |
| USB 4 | Reverse |
| USB 5 | Reverse |
| USB 6 | Card Reader |
| USB 7 | WLAN |
| USB 8 | CMOS Camera(D/B) |
| USB 9 | Reverse |
| USB 10 | Reverse |
| USB 11 | Reverse |

M1.1 For EMI CMOS form Port 4 change to Port 8

When supporting CLK GEN Turbo PIN, un-mount R1661.

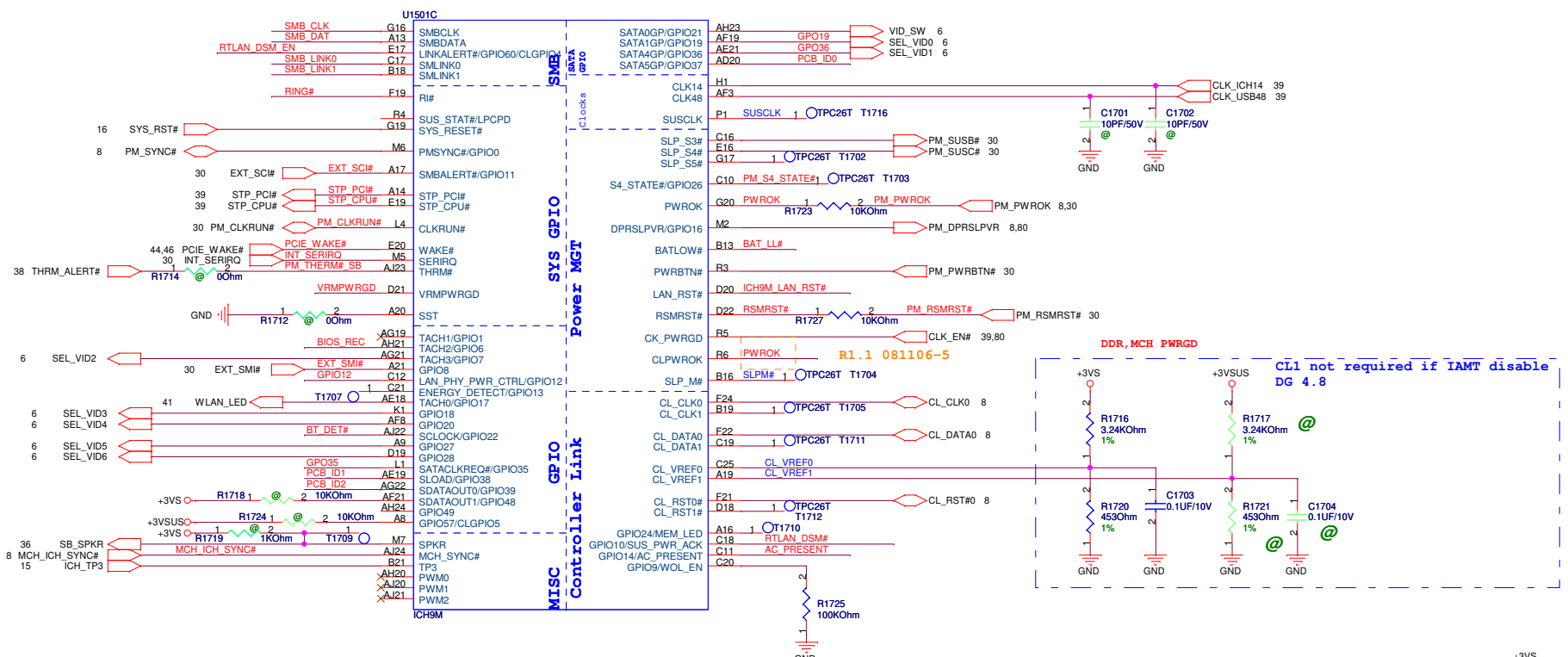

No Reboot Strap
 Low = Default
 High = No Reboot

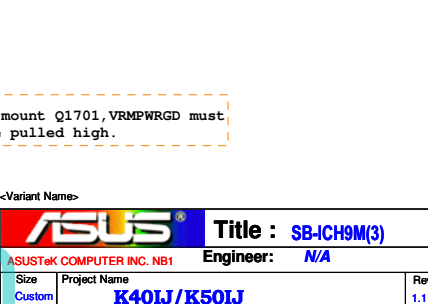
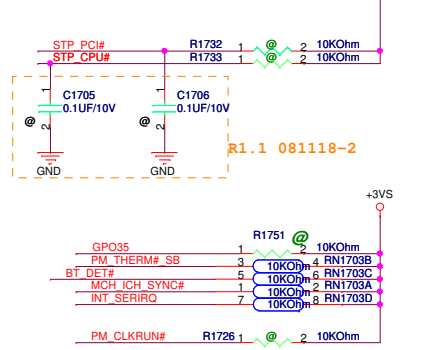
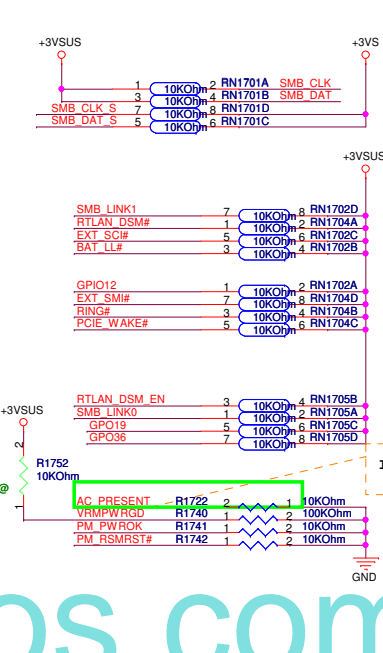
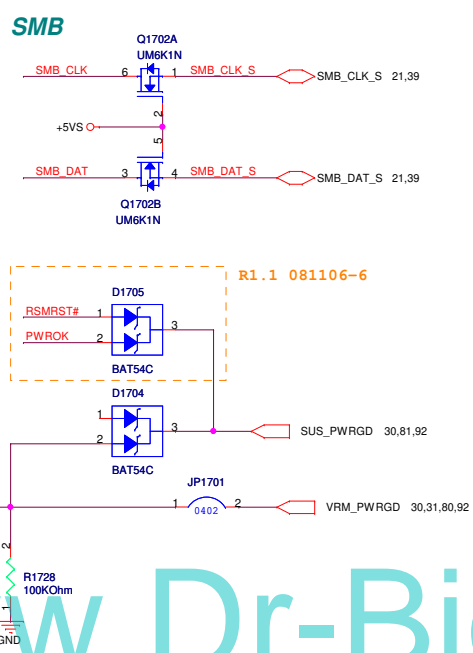
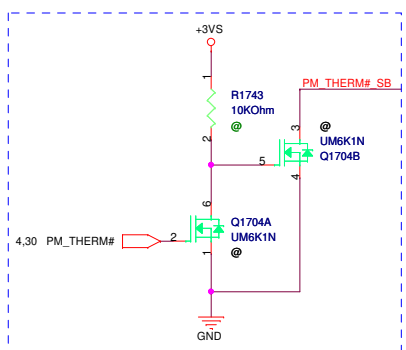
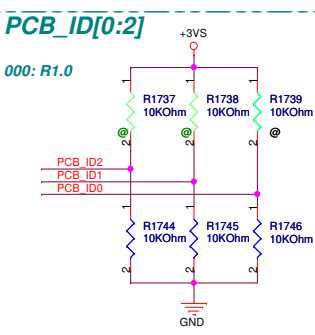
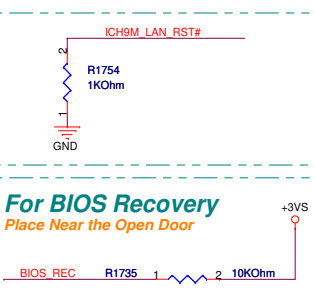

ASUS Title : SB-ICH9M(3)
 ASUSTek COMPUTER INC. NBI Engineer: N/A

| | | |
|------------------------------|--------------|----------|
| Size | Project Name | Rev |
| Custom | K40LJ/K50LJ | 1.1 |
| Date: Monday, March 09, 2009 | Sheet | 17 of 96 |

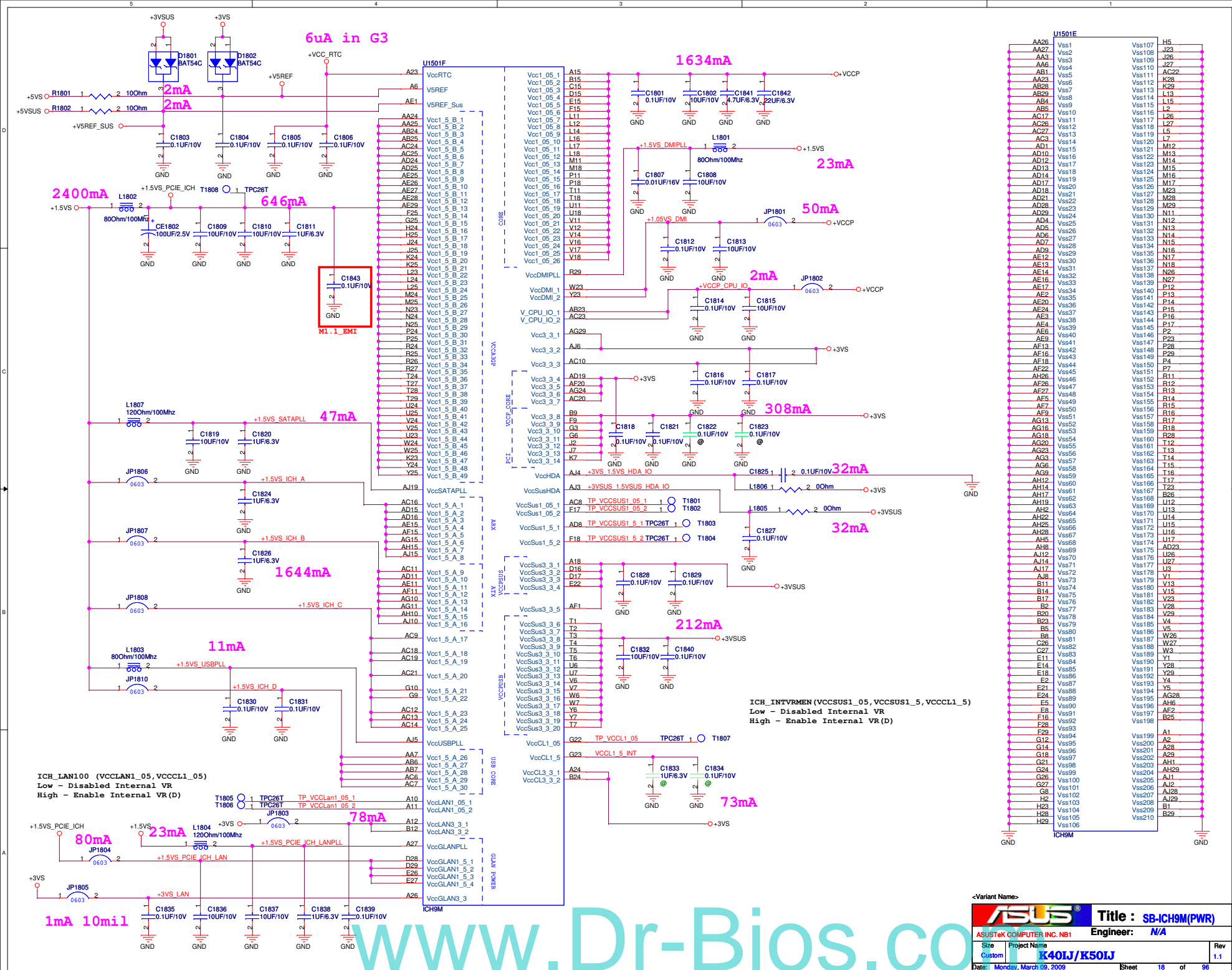

| AA26 | Vss1 | Vss107 | H5 |
|------|--------|--------|------|
| AA27 | Vss2 | Vss108 | J26 |
| AA3 | Vss3 | Vss109 | J27 |
| AA6 | Vss4 | Vss110 | J27 |
| AB1 | Vss5 | Vss111 | AC22 |
| AB23 | Vss6 | Vss112 | K26 |
| AB29 | Vss7 | Vss113 | K29 |
| AB5 | Vss8 | Vss114 | L13 |
| AB4 | Vss9 | Vss115 | L15 |
| AC17 | Vss10 | Vss116 | L26 |
| AC26 | Vss11 | Vss117 | L27 |
| AC27 | Vss12 | Vss118 | L5 |
| AC3 | Vss13 | Vss119 | L7 |
| AD1 | Vss14 | Vss120 | M12 |
| AD10 | Vss15 | Vss121 | M13 |
| AD12 | Vss16 | Vss122 | M14 |
| AD13 | Vss17 | Vss123 | M15 |
| AD14 | Vss18 | Vss124 | M16 |
| AD17 | Vss19 | Vss125 | M17 |
| AD18 | Vss20 | Vss126 | M23 |
| AD21 | Vss21 | Vss127 | M28 |
| AD22 | Vss22 | Vss128 | M29 |
| AD29 | Vss23 | Vss129 | N11 |
| AD4 | Vss24 | Vss130 | N11 |
| AD5 | Vss25 | Vss131 | N12 |
| AD6 | Vss26 | Vss132 | N13 |
| AD7 | Vss27 | Vss133 | N14 |
| AD9 | Vss28 | Vss134 | N15 |
| AE12 | Vss29 | Vss135 | N16 |
| AE13 | Vss30 | Vss136 | N17 |
| AE14 | Vss31 | Vss137 | N18 |
| AE16 | Vss32 | Vss138 | N26 |
| AE17 | Vss33 | Vss139 | N27 |
| AE20 | Vss34 | Vss140 | N34 |
| AE24 | Vss35 | Vss141 | P14 |
| AE3 | Vss36 | Vss142 | P15 |
| AE4 | Vss37 | Vss143 | P16 |
| AE6 | Vss38 | Vss144 | P17 |
| AE9 | Vss39 | Vss145 | P2 |
| AE13 | Vss40 | Vss146 | P28 |
| AE16 | Vss41 | Vss147 | P29 |
| AE18 | Vss42 | Vss148 | P4 |
| AF22 | Vss43 | Vss149 | P7 |
| AF26 | Vss44 | Vss150 | P17 |
| AF27 | Vss45 | Vss151 | R11 |
| AF5 | Vss46 | Vss152 | R12 |
| AF7 | Vss47 | Vss153 | R13 |
| AG20 | Vss48 | Vss154 | R14 |
| AG3 | Vss49 | Vss155 | R16 |
| AG6 | Vss50 | Vss156 | R17 |
| AG9 | Vss51 | Vss157 | R18 |
| AH12 | Vss52 | Vss158 | R28 |
| AH14 | Vss53 | Vss159 | T12 |
| AH19 | Vss54 | Vss160 | T13 |
| AH2 | Vss55 | Vss161 | T14 |
| AH22 | Vss56 | Vss162 | T15 |
| AH25 | Vss57 | Vss163 | T16 |
| AH28 | Vss58 | Vss164 | T17 |
| AH5 | Vss59 | Vss165 | T23 |
| AH8 | Vss60 | Vss166 | T26 |
| AH12 | Vss61 | Vss167 | T3 |
| AH14 | Vss62 | Vss168 | T12 |
| AH17 | Vss63 | Vss169 | T13 |
| AH22 | Vss64 | Vss170 | T14 |
| AH25 | Vss65 | Vss171 | T15 |
| AH28 | Vss66 | Vss172 | T16 |
| AH5 | Vss67 | Vss173 | T17 |
| AH8 | Vss68 | Vss174 | AD23 |
| AH12 | Vss69 | Vss175 | L26 |
| AH14 | Vss70 | Vss176 | U27 |
| AH17 | Vss71 | Vss177 | U3 |
| AH19 | Vss72 | Vss178 | V1 |
| AH2 | Vss73 | Vss179 | V13 |
| AH25 | Vss74 | Vss180 | V15 |
| AH28 | Vss75 | Vss181 | V23 |
| AH5 | Vss76 | Vss182 | V28 |
| AH8 | Vss77 | Vss183 | V29 |
| AH12 | Vss78 | Vss184 | V4 |
| AH14 | Vss79 | Vss185 | V5 |
| AH17 | Vss80 | Vss186 | W26 |
| AH19 | Vss81 | Vss187 | W3 |
| AH2 | Vss82 | Vss188 | W3 |
| AH25 | Vss83 | Vss189 | Y1 |
| AH28 | Vss84 | Vss190 | Y28 |
| AH5 | Vss85 | Vss191 | Y4 |
| AH8 | Vss86 | Vss192 | Y5 |
| AH12 | Vss87 | Vss193 | AC28 |
| AH14 | Vss88 | Vss194 | AH6 |
| AH17 | Vss89 | Vss195 | AF2 |
| AH19 | Vss90 | Vss196 | AF2 |
| AH2 | Vss91 | Vss197 | B25 |
| AH25 | Vss92 | Vss198 | B25 |
| AH28 | Vss93 | Vss199 | A1 |
| AH5 | Vss94 | Vss200 | A2 |
| AH8 | Vss95 | Vss201 | A28 |
| AH12 | Vss96 | Vss202 | A29 |
| AH14 | Vss97 | Vss203 | AH1 |
| AH17 | Vss98 | Vss204 | AH29 |
| AH19 | Vss99 | Vss205 | A11 |
| AH2 | Vss100 | Vss206 | A12 |
| AH25 | Vss101 | Vss207 | A28 |
| AH28 | Vss102 | Vss208 | B1 |
| AH5 | Vss103 | Vss209 | B1 |
| AH8 | Vss104 | Vss210 | B29 |
| AH12 | Vss105 | Vss210 | B29 |
| AH14 | Vss106 | Vss210 | B29 |

ICH_LAN100 (VCCLAN1_05, VCCCL1_05)
 Low - Disabled Internal VR
 High - Enable Internal VR (D)

ICH_INTVRM (VCCSUS1_05, VCCSUS1_5, VCCCL1_5)
 Low - Disabled Internal VR
 High - Enable Internal VR (D)

<Variant Name>

ASUS Title : SB-ICH9M(PWR)

ASUSTeK COMPUTER INC. NBI Engineer: N/A

| | | |
|--------|--------------|-----|
| Size | Project Name | Rev |
| Custom | K40IJ/K50IJ | 1.1 |

Date: Monday, March 09, 2009 Sheet 18 of 96

5

4

3

2

1

D

D

C

C

B

B

A

A

www.Dr-Bios.com

<Variant Name>

| | | | |
|---|------------------------|------------------------------------|----------|
|  | | Title : Schematic page name | |
| ASUSTeK COMPUTER INC | | Engineer: N/A | |
| Size | Project Name | Rev | |
| Custom | K40IJ/K50IJ | 1.1 | |
| Date: | Monday, March 09, 2009 | Sheet | 19 of 96 |

5

4

3

2

1

D

D

C

C

B

B

A

A

www.Dr-Bios.com

<Variant Name>

| | | | |
|---|--------------------|------------------------------|----------|
|  | | Title : DDR2 SO-DIMM0 | |
| ASUSTeK COMPUTER INC. NB1 | | Engineer: N/A | |
| Size | Project Name | | Rev |
| A3 | K40IJ/K50IJ | | 1.1 |
| Date: Monday, March 09, 2009 | | Sheet | 20 of 96 |

5

4

3

2

1

DDR2 200P H=9.2mm (Reverse Type)

M_B_DQ[63:0] 10

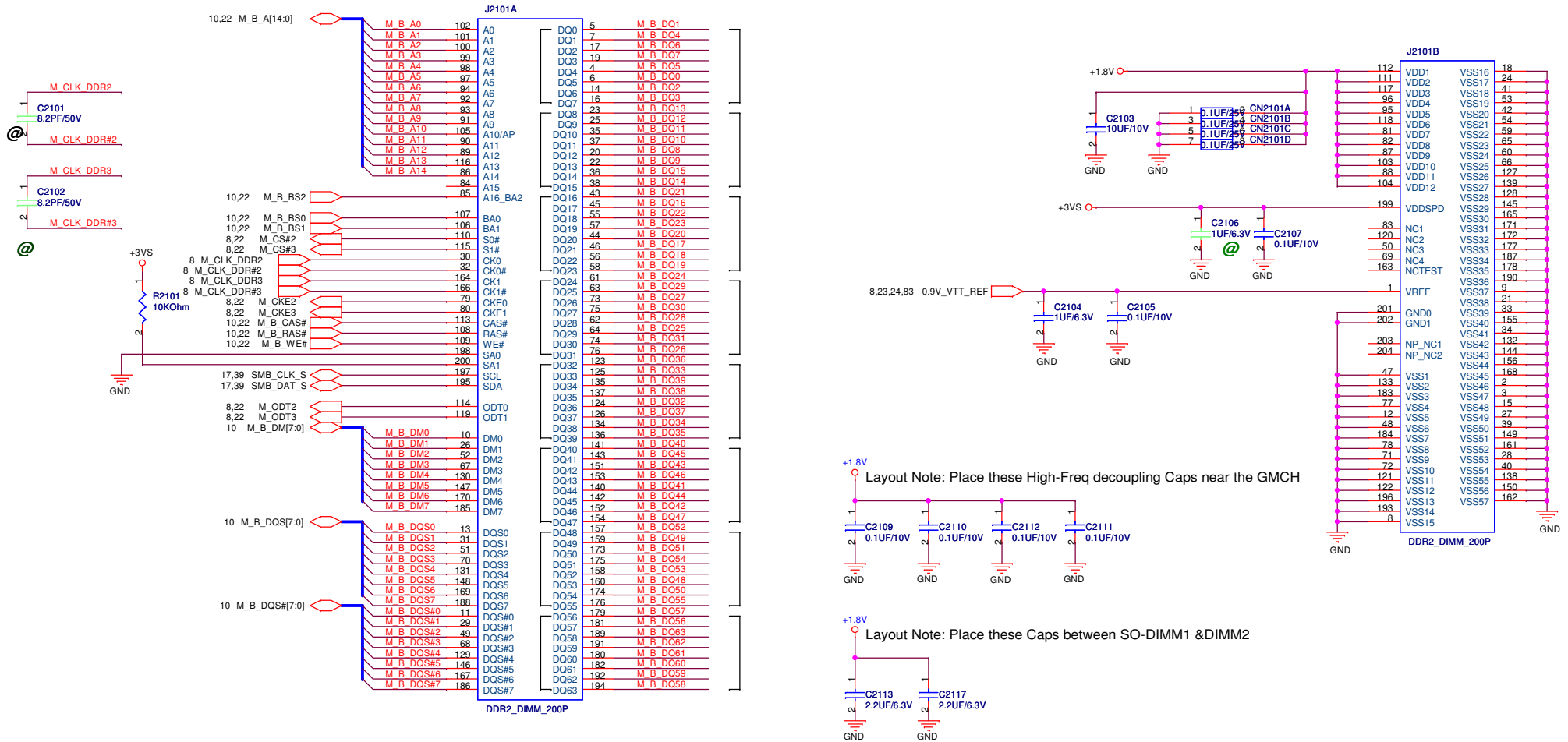

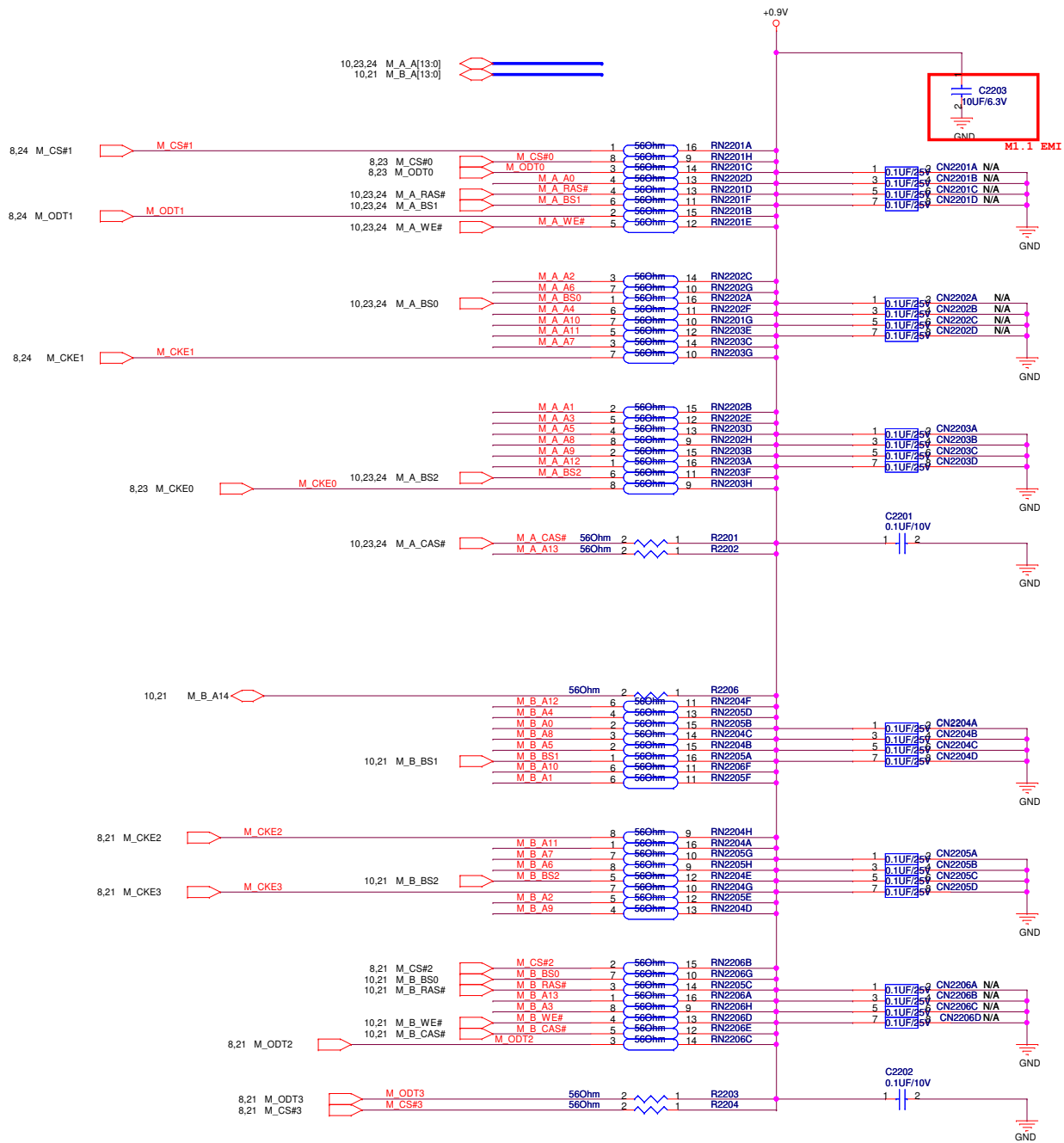

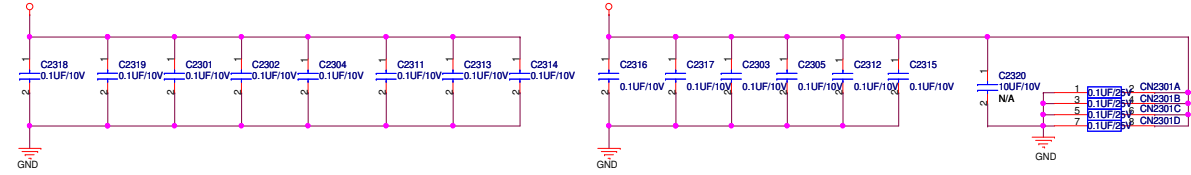
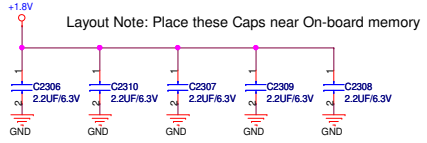
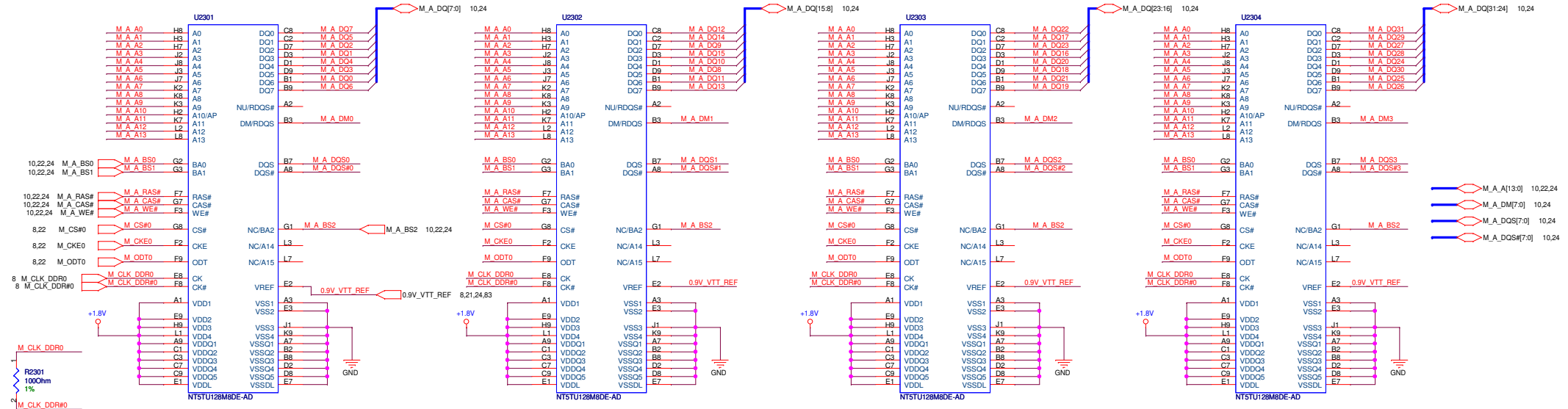

ASUS Title : Schematic page name
 ASUSTek COMPUTER INC Engineer: N/A
 Size Project Name
 Custom K40LJ/K50LJ
 Date: Monday, March 09, 2009 Sheet 23 of 96

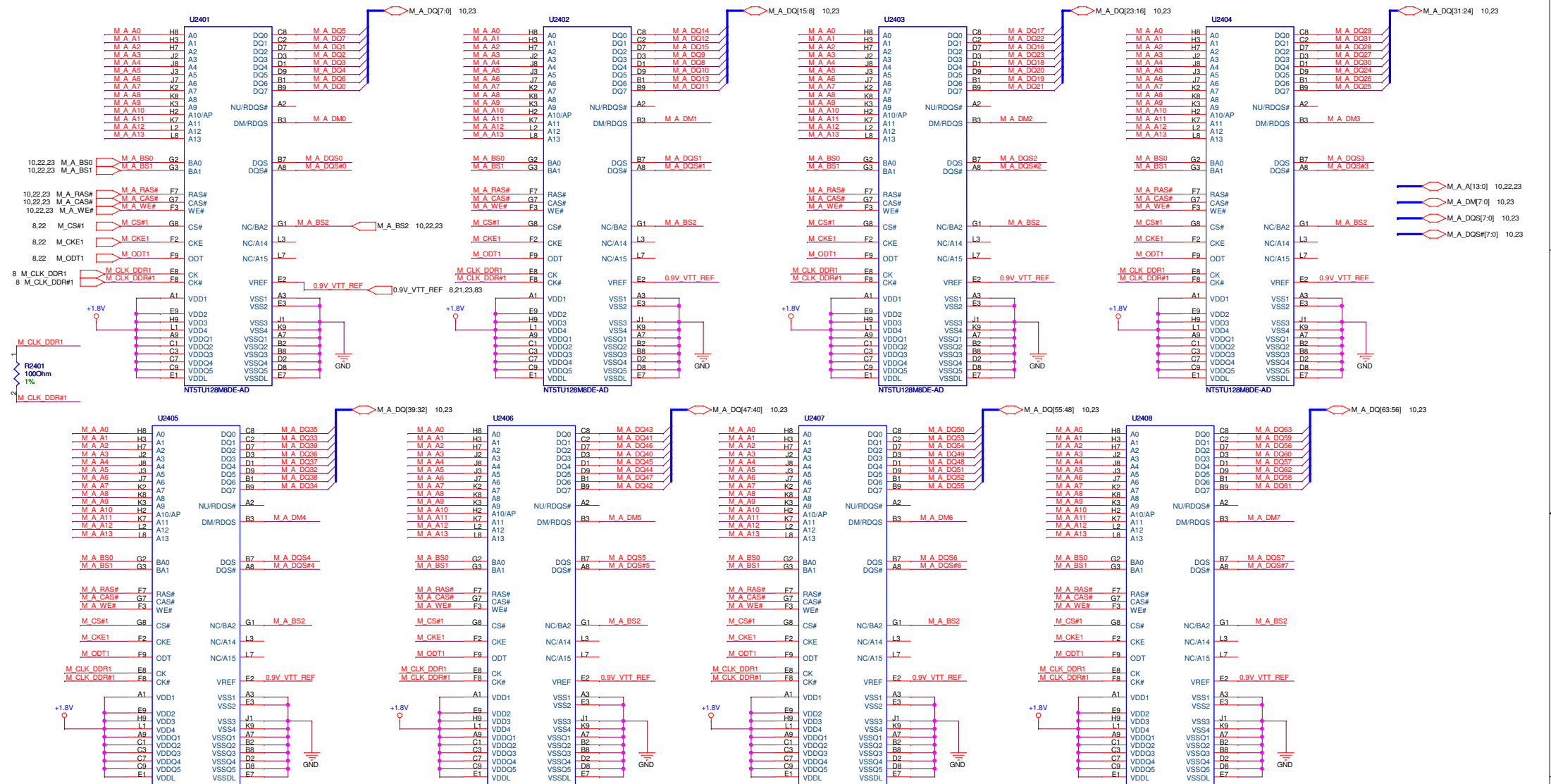

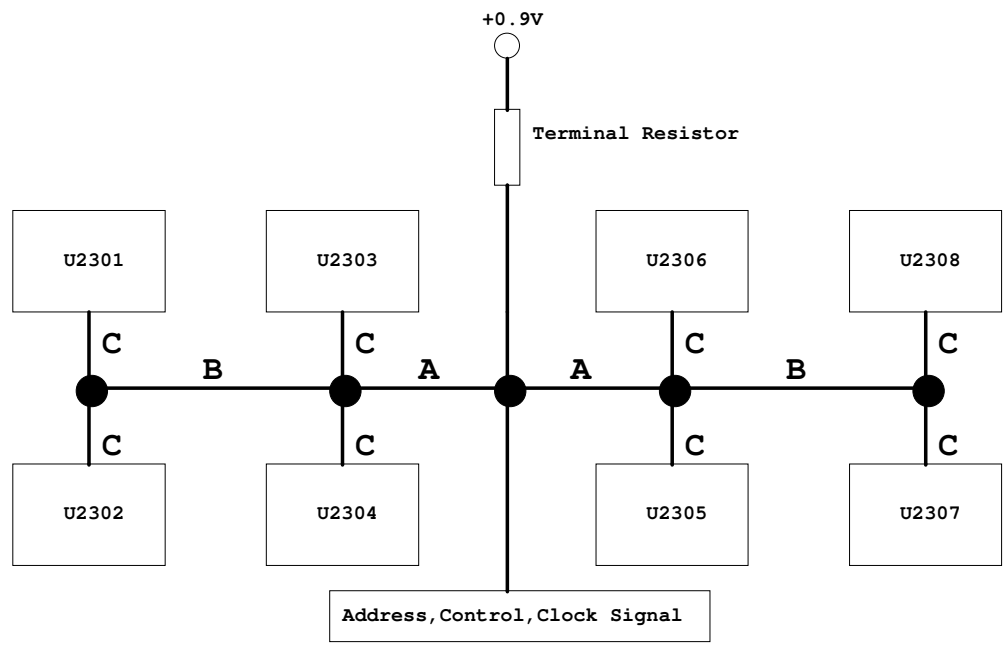

www.Dr-Bios.com

5

4

3

2

1

D

D

C

C

B

B

A

A

www.Dr-Bios.com

<Variant Name>

| | | | |
|---|--------------|-----------------------------|--|
|  | | Title : Schematic page name | |
| ASUSTek COMPUTER INC | | Engineer: Alex&Bruce | |
| Size | Project Name | Rev | |
| Custom | K40IJ/K50IJ | 1.1 | |
| Date: Monday, March 09, 2009 | Sheet 26 | of 96 | |

5

4

3

2

1

D

D

C

C

B

B

A

A

www.Dr-Bios.com

<Variant Name>

| | | | |
|---|------------------------|------------------------------------|----------|
|  | | Title : Schematic page name | |
| ASUSTek COMPUTER INC | | Engineer: N/A | |
| Size | Project Name | Rev | |
| Custom | K40IJ/K50IJ | 1.1 | |
| Date: | Monday, March 09, 2009 | Sheet | 27 of 96 |

5

4

3

2

1

D

D

C

C

B

B

A

A

www.Dr-Bios.com

<Variant Name>

| | | | |
|---|--------------|-----------------------------|-------|
|  | | Title : Schematic page name | |
| ASUSTek COMPUTER INC | | Engineer: N/A | |
| Size | Project Name | Rev | |
| Custom | K40IJ/K50IJ | 1.1 | |
| Date: Monday, March 09, 2009 | Sheet | 28 | of 96 |

5

4

3

2

1

5

4

3

2

1

D

D

C

C

B

B

A

A

www.Dr-Bios.com

| | | | |
|------------------------------|--------------------|----------------------|-------|
| ASUS | | Title : N/A | |
| ASUSTek COMPUTER INC | | Engineer: N/A | |
| Size | Project Name | Rev | |
| Custom | K40IJ/K50IJ | 1.1 | |
| Date: Monday, March 09, 2009 | Sheet | 29 | of 96 |

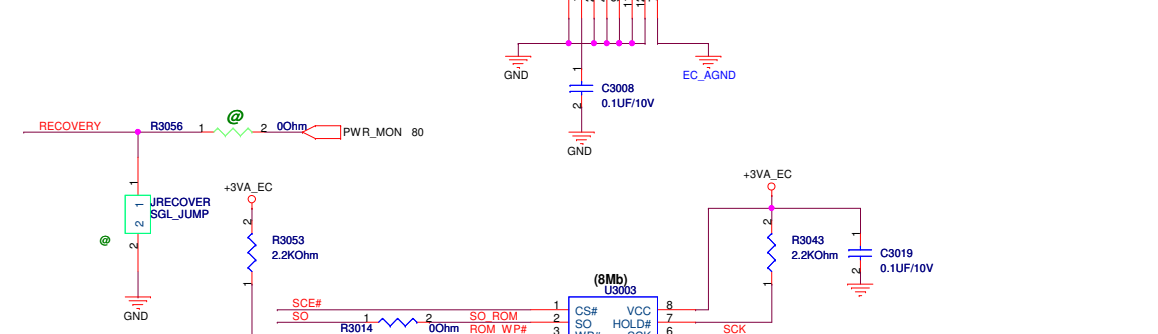
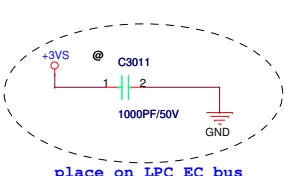

For IT8702 Power

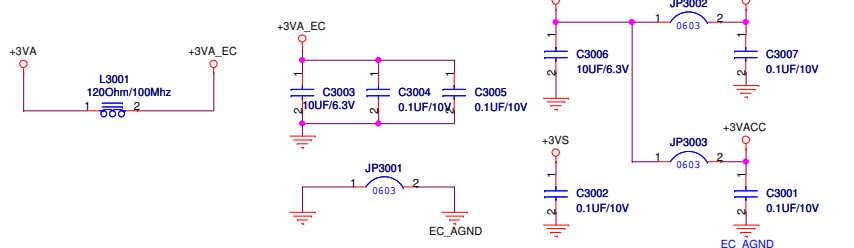

For PU / PD

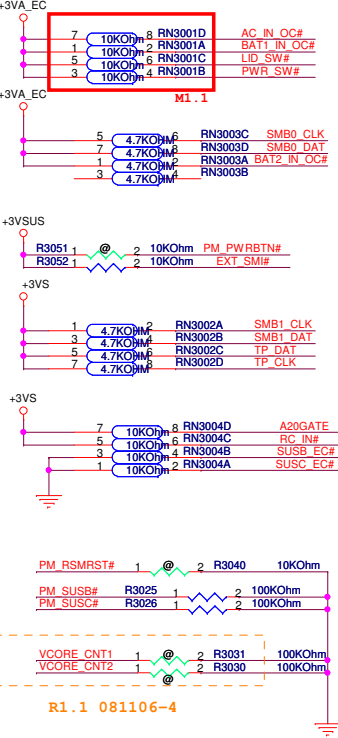

For EC Reset

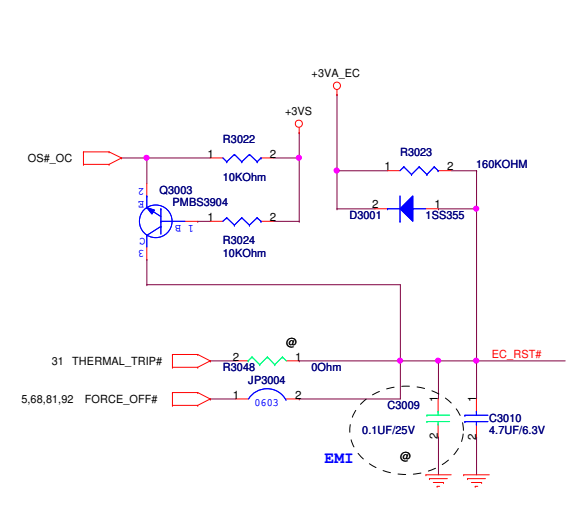

For Instant Key

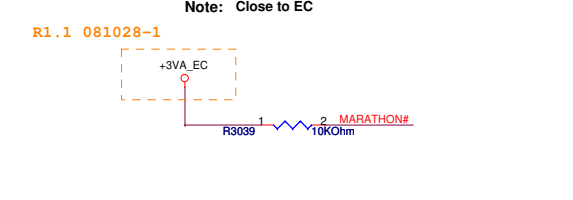

For X'tal

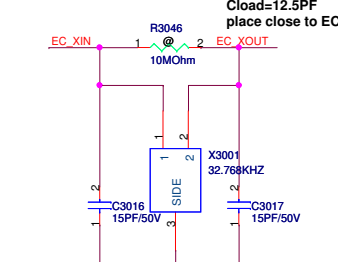

For EC Hardware Strap

I/O Base Address
 Note: It can be programmable by EC firmware
 Share Memory
 Note: It can be programmable by EC firmware.
 PP Enable
 Note: Default Int. Pull-Low

For iAMT pin name

- AC_PRESENT
- PM_S4_STATE#
- S4_STATE_ON
- PM_SLP_M#
- SLP_LON
- EC_WLAN_PWR
- MP_PWRGD
- AC_PRESENT
- LAN_WOL_EN
- +3VM_PG
- +1.5VM_+3VMCLK_PG
- SUSPWR_ACK

www.Dr-Bios.com

Title : EC_IT8512E-L (1/2)
 ASUSTeK COMPUTER INC. NBI **Engineer: Wendell Lo**

| | | |
|--------|--------------------|-----|
| Size | Project Name | Rev |
| Custom | K40IJ/K50IJ | 1.1 |

Date: Monday, March 09, 2009 Sheet 30 of 96

TouchPad & FingerPrint

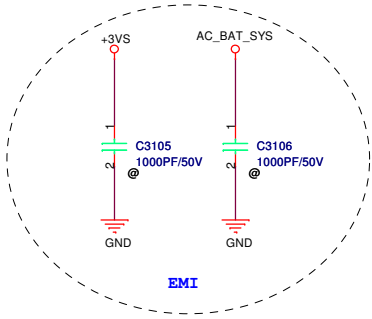
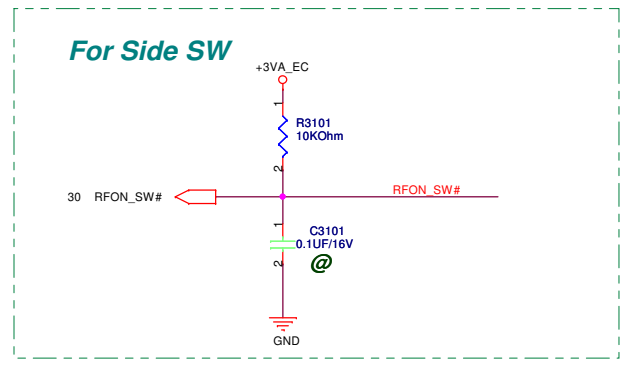
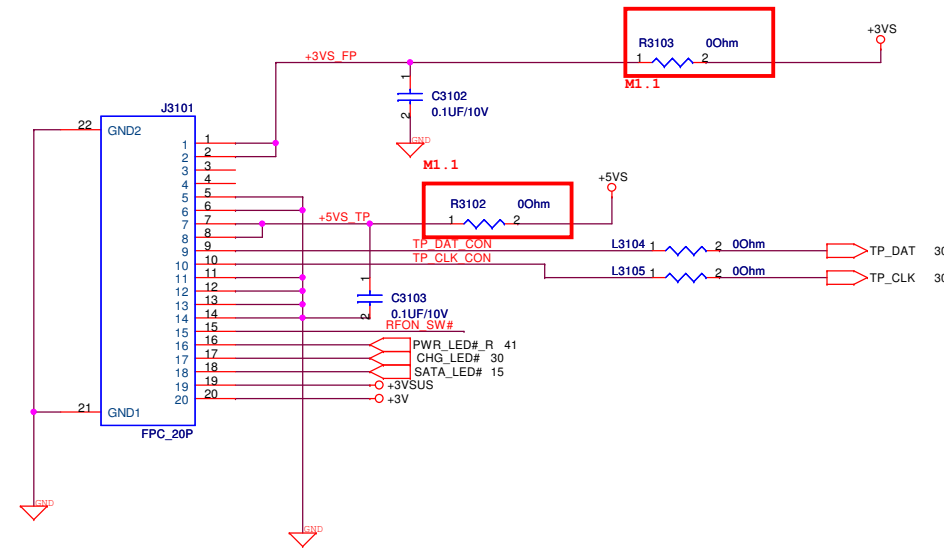

For Thermal Control Method

Remove redundant components

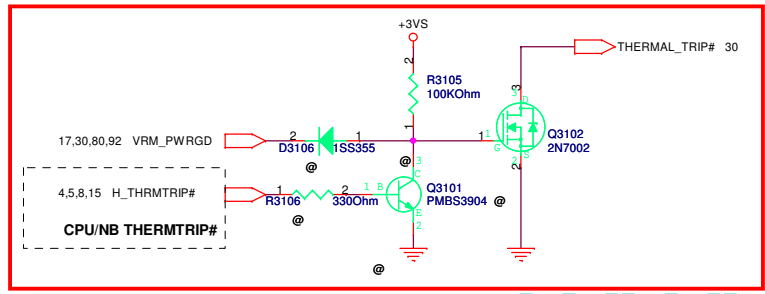

Keyboard Connector

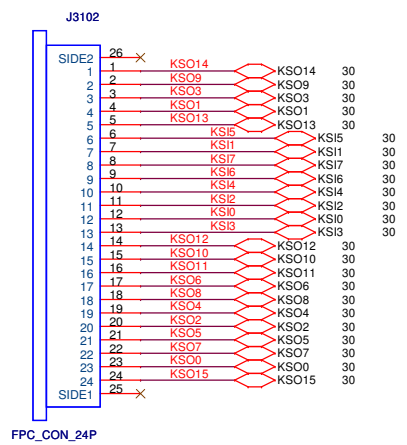

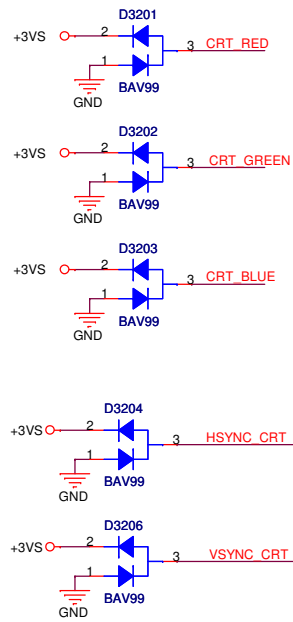

PLACE ESD Diodes near VGA port

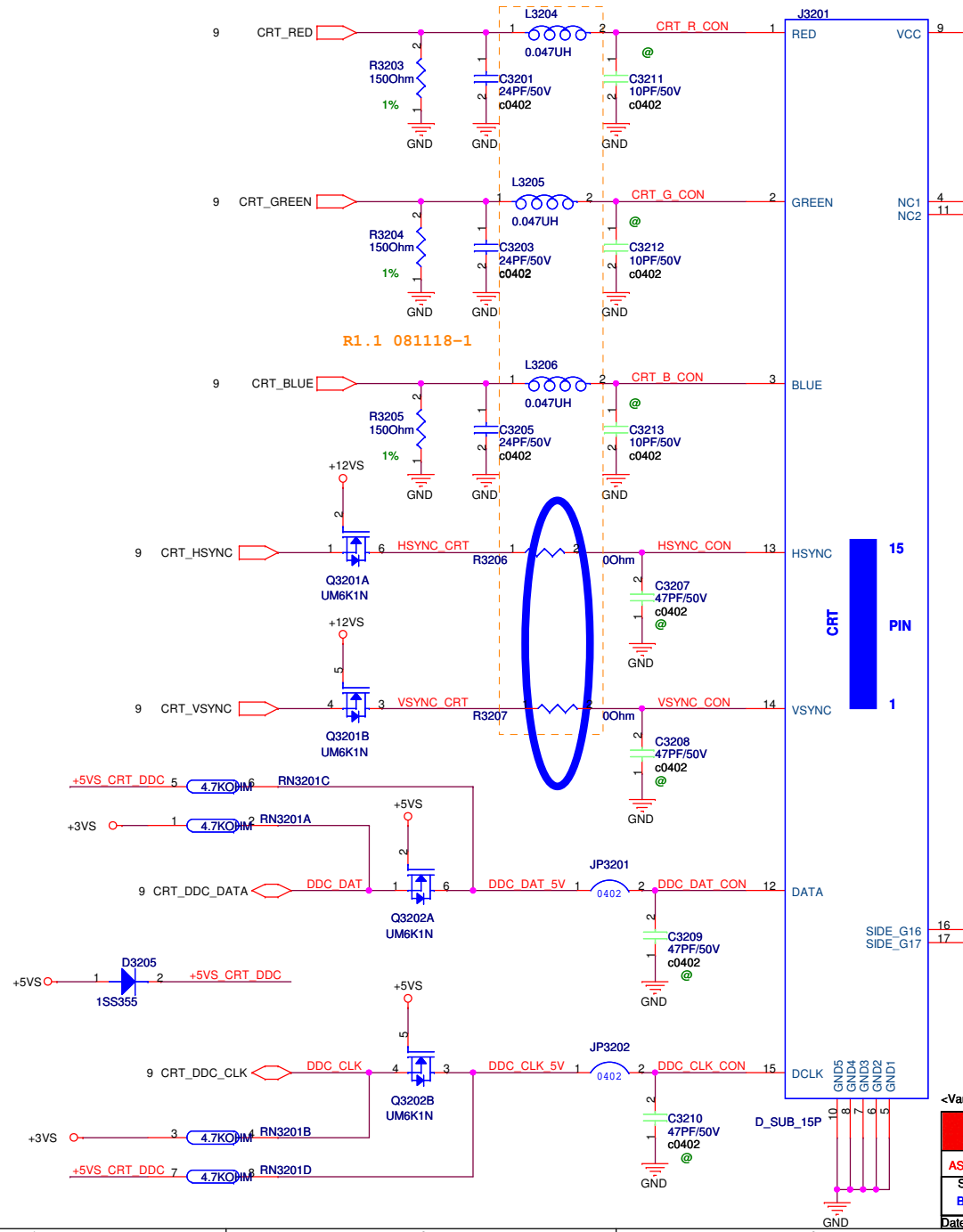

| | | | |
|------------------------------|-----------------------------|------------------------------------|----------|
| | | Title : CRT | |
| | | ASUSTeK COMPUTER INC Engineer: N/A | |
| Size B | Project Name K401J/K501J | Rev 1.1 | |
| Date: Monday, March 09, 2009 | | Sheet | 32 of 96 |

LCD Power

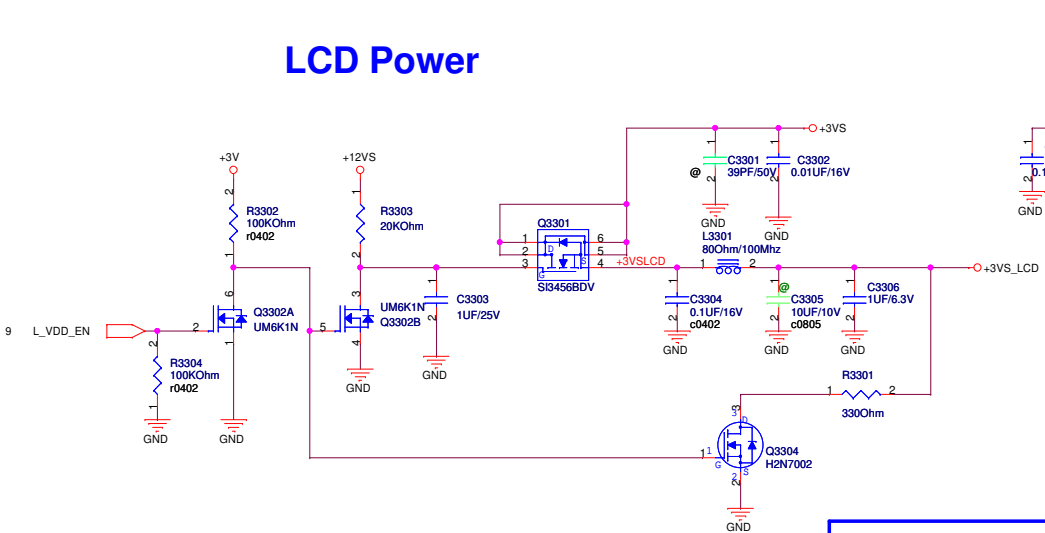

LED PANEL LVDS Interface

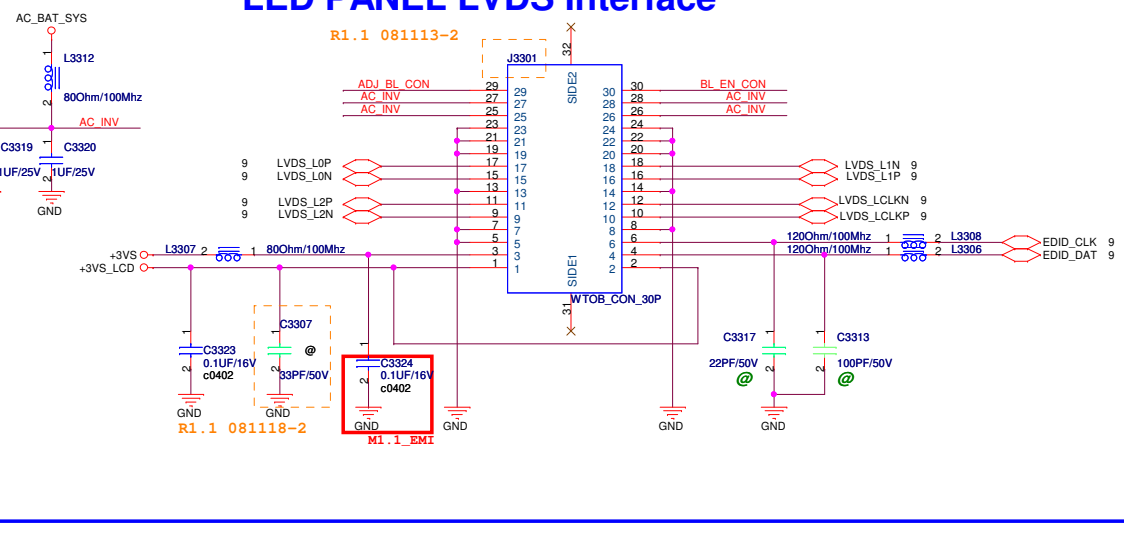

CAMERA & MIC

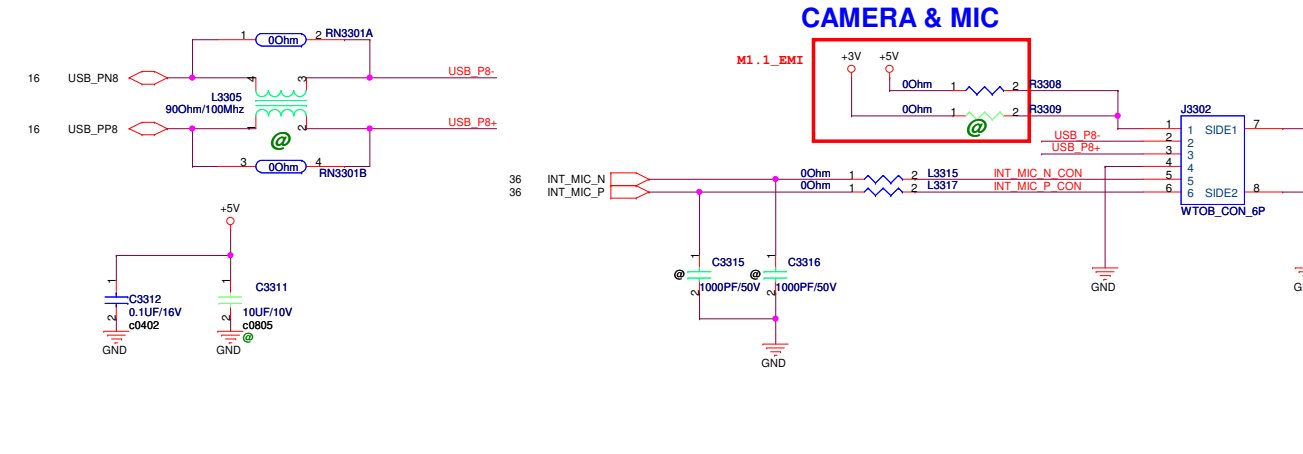

Hall effect switch

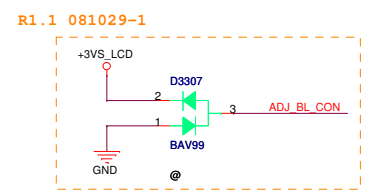
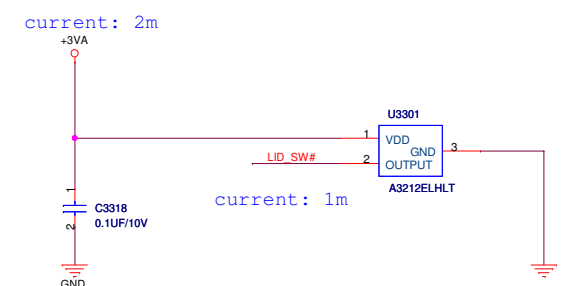

| | |
|------------------------------|----------------|
| Title : LVDS & INVERTER | |
| ASUSTek COMPUTER INC | Engineer: N/A |
| Size | Project Name |
| Custom | K40LJ/K50LJ |
| Date: Monday, March 09, 2009 | Sheet 33 of 96 |
| Rev 1.1 | |

5

4

3

2

1

D

D

C

C

B

B

A

A

For Bluetooth

www.Dr-Bios.com

| | | | |
|---|-----------------------------|-------------------------------|--|
| <small><Variant Name></small> | | | |
|  | | Title : BT | |
| <small>ASUSTeK COMPUTER INC</small> | | Engineer: N/A | |
| <small>Size</small> | <small>Project Name</small> | <small>Rev</small> | |
| <small>Custom</small> | K40IJ/K50IJ | 1.1 | |
| <small>Date: Monday, March 09, 2009</small> | | <small>Sheet 34 of 96</small> | |



| | | | |
|------------------------------|--------------|---------------|----------|
| ASUS [®] | | Title : N/A | |
| ASUSTek COMPUTER INC | | Engineer: N/A | |
| Size | Project Name | Rev | |
| A | K40IJ/K50IJ | 1.1 | |
| Date: Monday, March 09, 2009 | | Sheet | 35 of 96 |

www.Dr-Bios.com

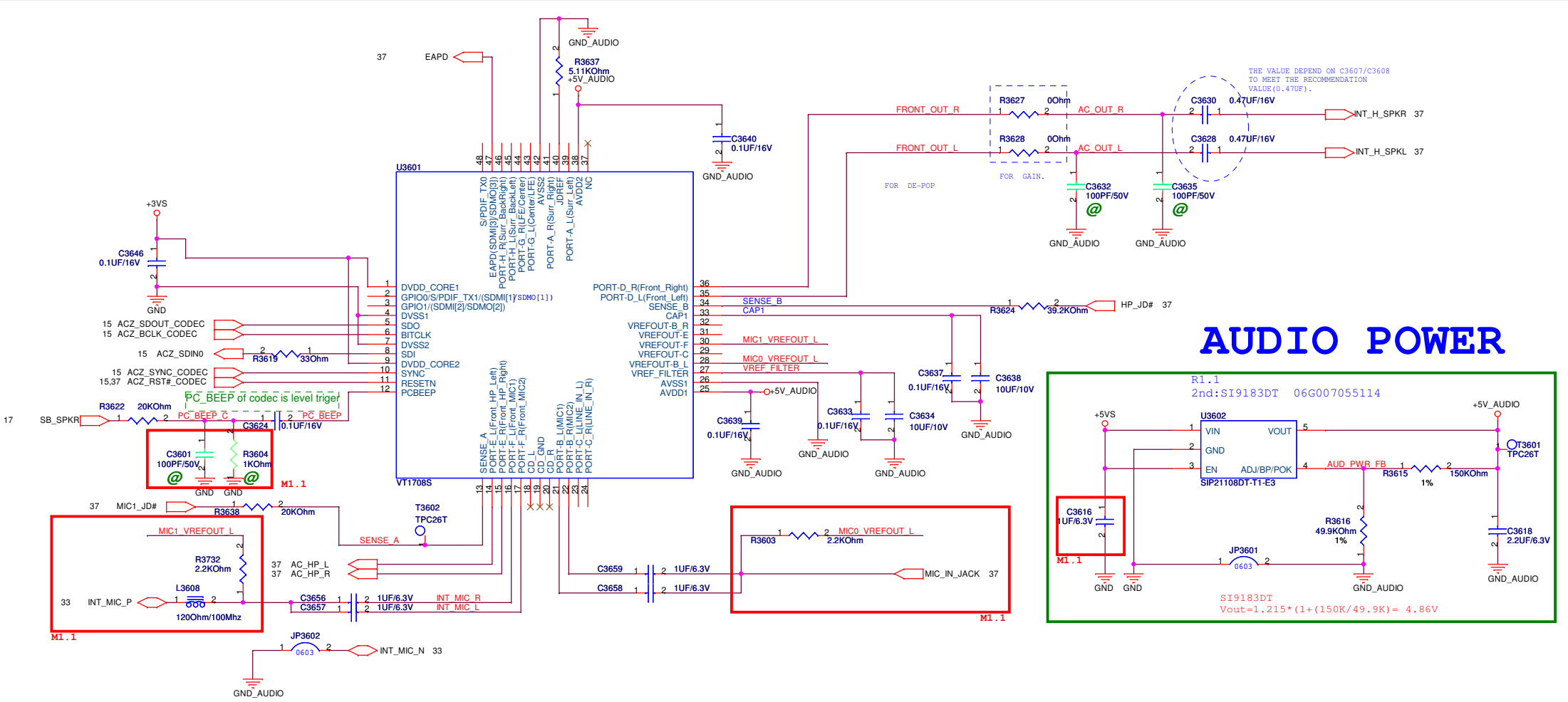

AUDIO POWER

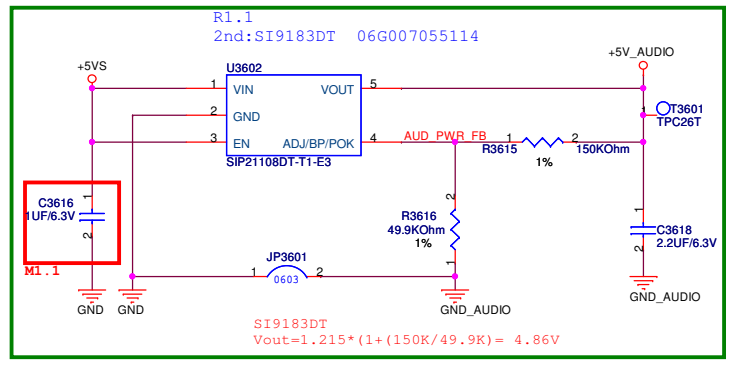

<Variant Name>

| | | | |
|------------------------------|--------------------|---------------------------------|----------|
| ASUS | | Title : CONEXANT CX20582 | |
| ASUSTeK COMPUTER INC | | Engineer: N/A | |
| Size | Project Name | | Rev |
| Custom | K401J/K501J | | 1.1 |
| Date: Monday, March 09, 2009 | | Sheet | 36 of 96 |

HP CONN

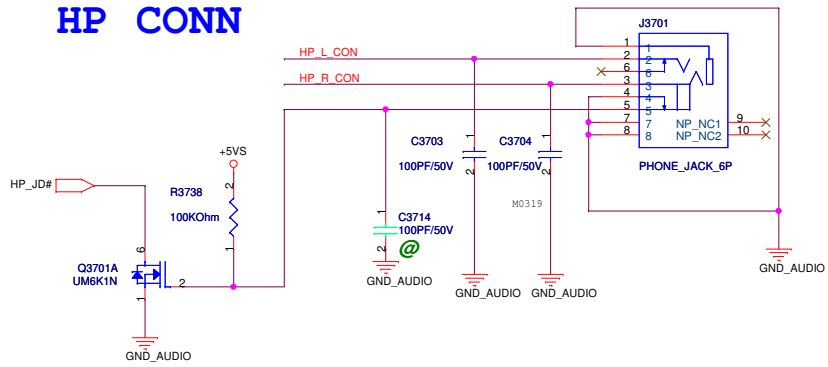

External MIC CONN

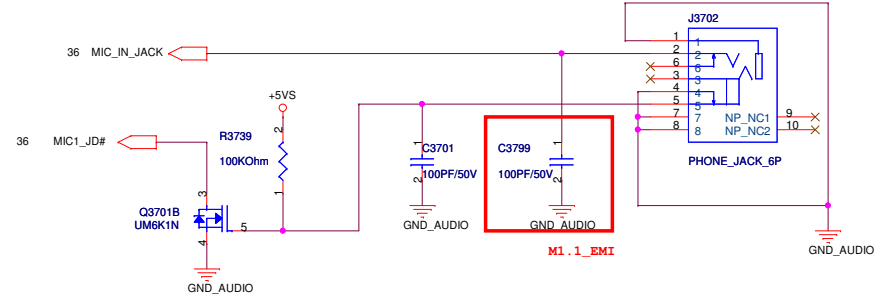

MUTE CONTROL

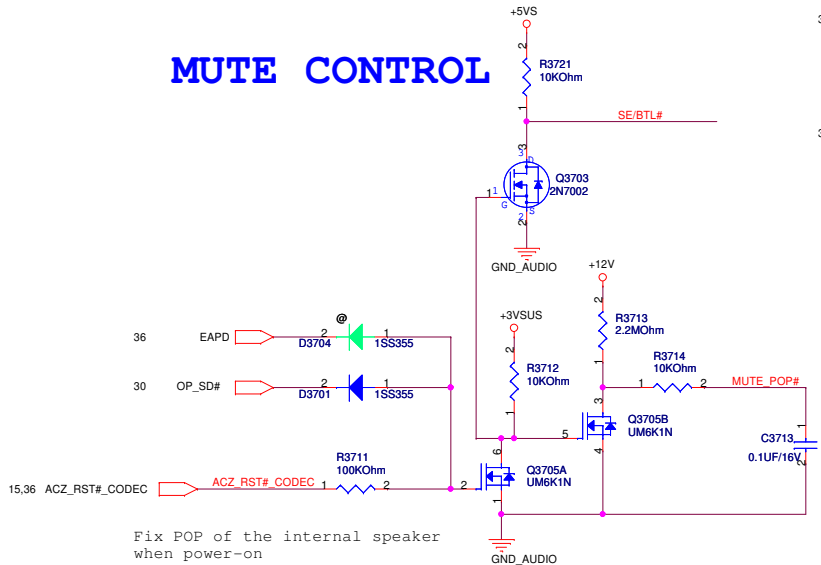

Fix POP of the internal speaker when power-on

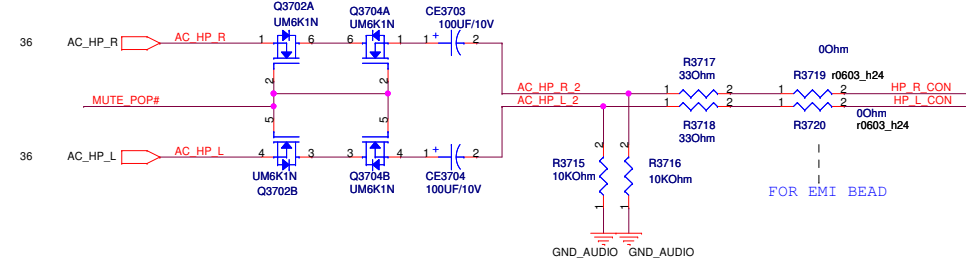

SPEAKER CONNECTOR (2W)

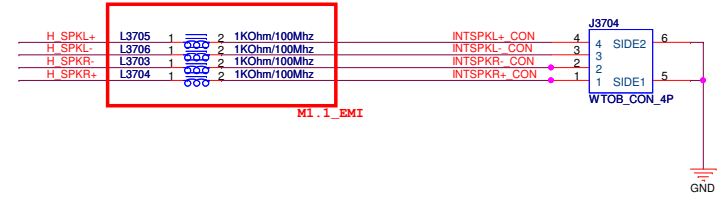

SPEAKER AMP

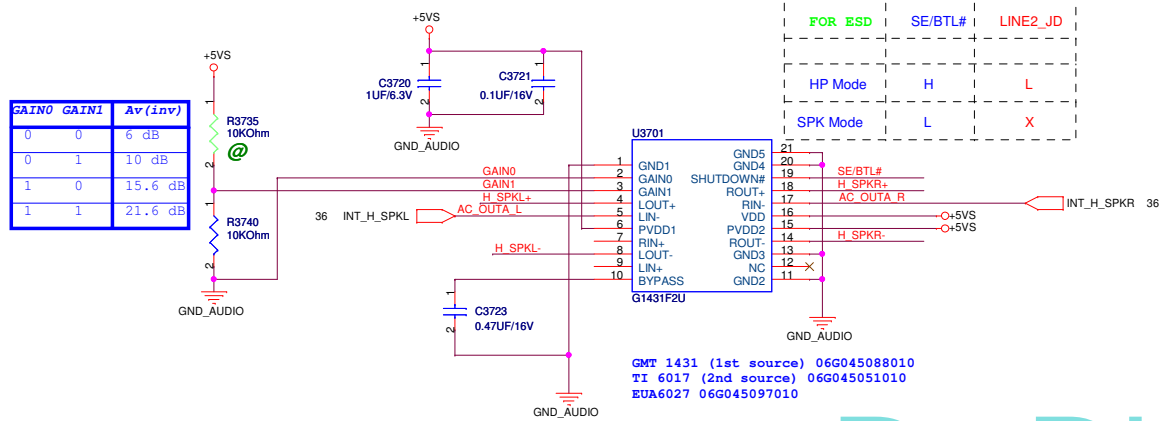

| GAIN0 | GAIN1 | Av (inv) |
|-------|-------|----------|
| 0 | 0 | 6 dB |
| 0 | 1 | 10 dB |
| 1 | 0 | 15.6 dB |
| 1 | 1 | 21.6 dB |

GMT 1431 (1st source) 06G045088010
 TI 6017 (2nd source) 06G045051010
 EUA6027 06G045097010

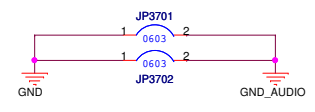

Thermal Sensor

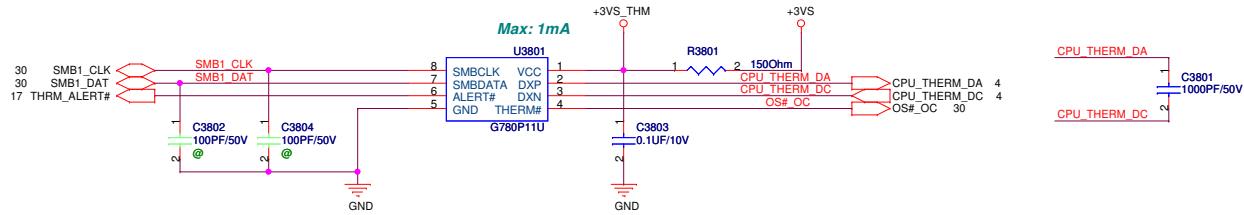
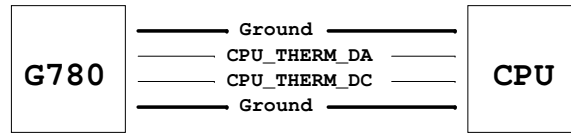

add 2nd source : 06G023096010

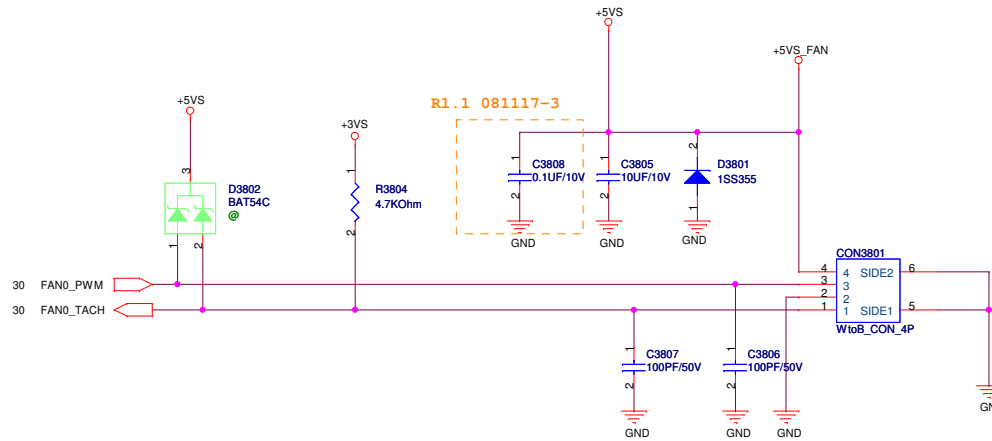

<Variant Name>

| | | | |
|------------------------------|--------------|--------------------------------------|-------|
| ASUS | | Title : THER SENSOR & FAN | |
| ASUSTeK COMPUTER INC. NB1 | | Engineer: N/A | |
| Size | Project Name | Rev | |
| Custom | K40IJ/K50IJ | 1.1 | |
| Date: Monday, March 09, 2009 | Sheet | 38 | of 96 |

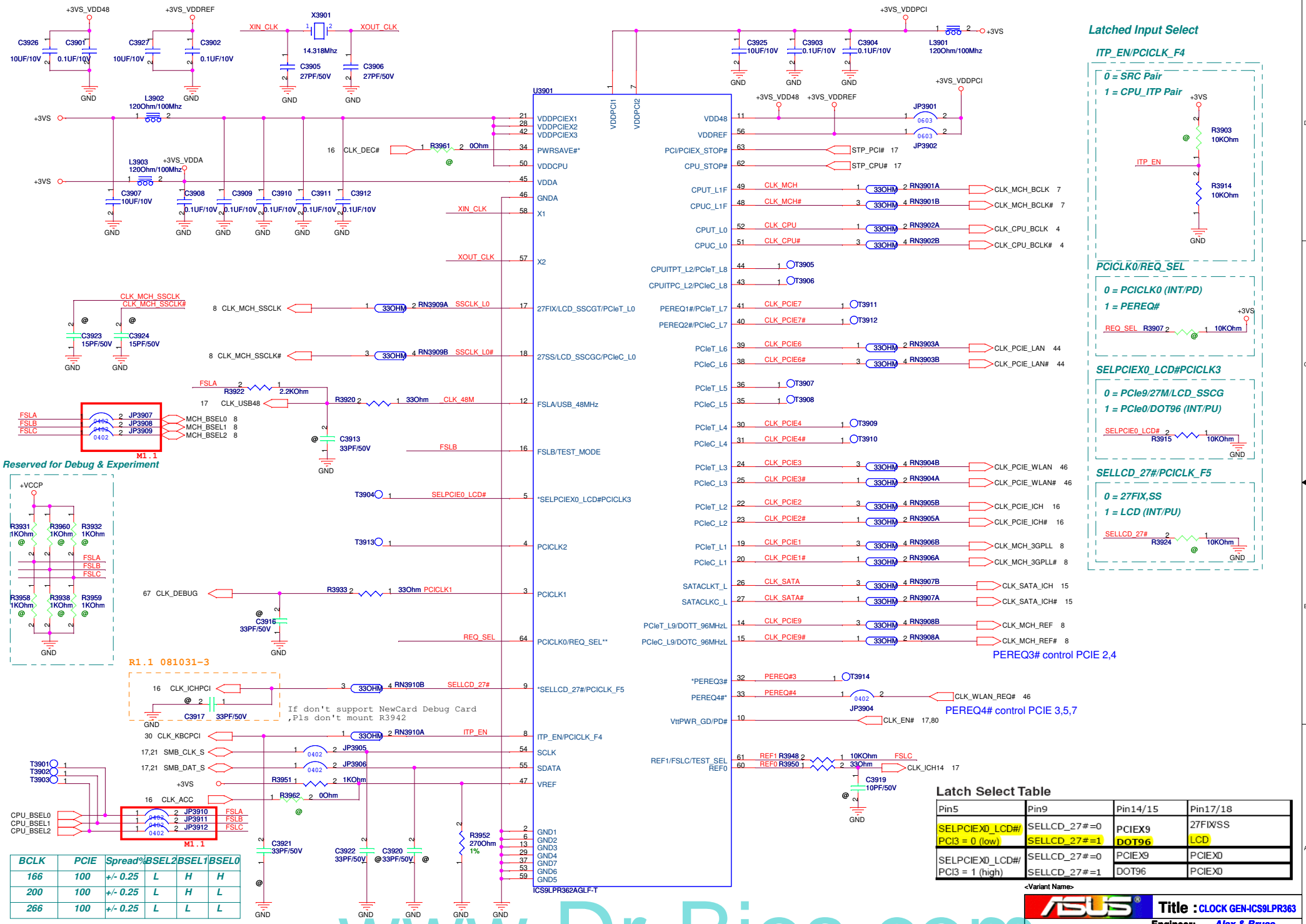

Latched Input Select

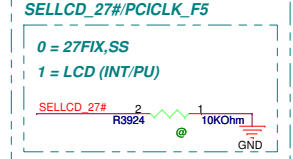
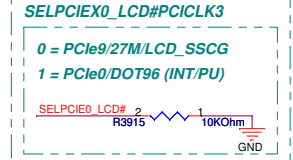
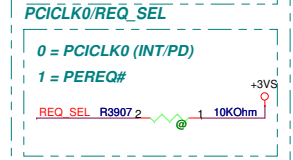
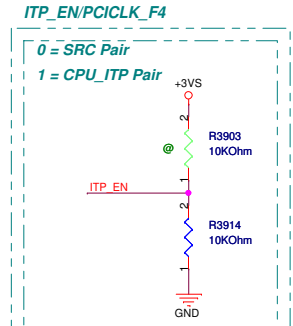

PEREQ3# control PCIE 2,4

PEREQ4# control PCIE 3,5,7

Latch Select Table

| Pin5 | Pin9 | Pin14/15 | Pin17/18 |
|------------------------------------|----------------------------------|----------------|-----------------|
| SELPCIE0_LCD#/ PCIE3 = 0 (low) | SELLCD_27# = 0 SELLCD_27# = 1 | PCIE9 DOT96 | 27FIX/SS LCD |
| SELPCIE0_LCD#/ PCIE3 = 1 (high) | SELLCD_27# = 0 SELLCD_27# = 1 | PCIE9 DOT96 | PCIE9 PCIE9 |

Reserved for Debug & Experiment

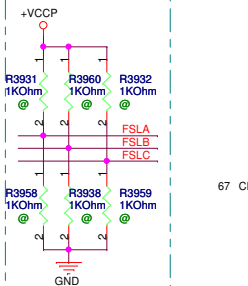

R1.1 081031-3

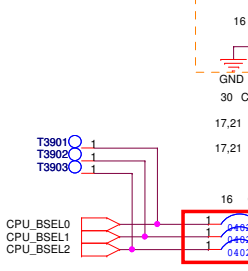

| BCLK | PCIE | Spread% | BSEL2 | BSEL1 | BSEL0 |
|------|------|----------|-------|-------|-------|
| 166 | 100 | +/- 0.25 | L | H | H |
| 200 | 100 | +/- 0.25 | L | H | L |
| 266 | 100 | +/- 0.25 | L | L | L |

5

4

3

2

1

D

D

C

C

B

B

A

A

www.Dr-Bios.com

| | | |
|---|--------------|-----------------------------|
| <Variant Name> | | |
|  | | Title : Schematic page name |
| ASUSTeK COMPUTER INC | | Engineer: N/A |
| Size | Project Name | Rev |
| Custom | K40IJ/K50IJ | 1.1 |
| Date: Monday, March 09, 2009 | Sheet 40 | of 96 |

SWITCH BUTTON

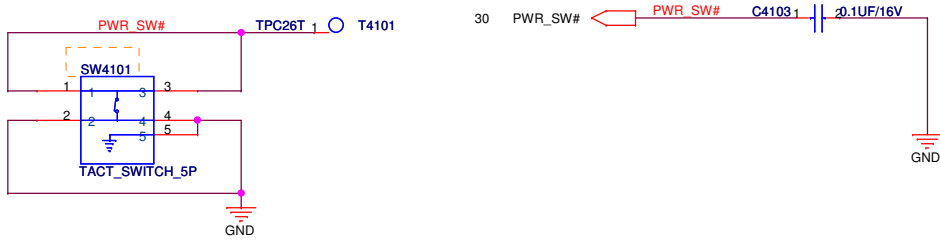

LED

For WireLess LED

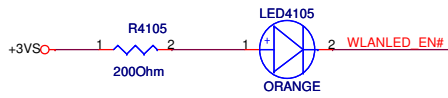

for Cap. Lock

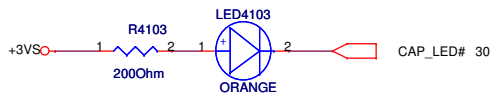

for Num Lock

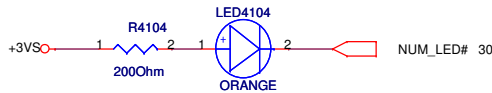

R1.1 081031-4

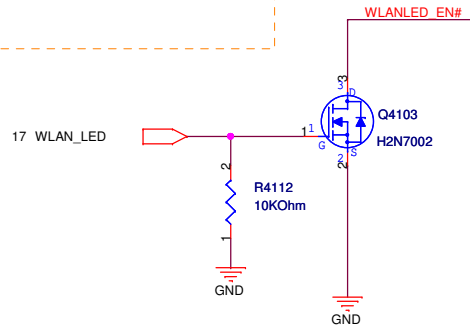

For POWER LED

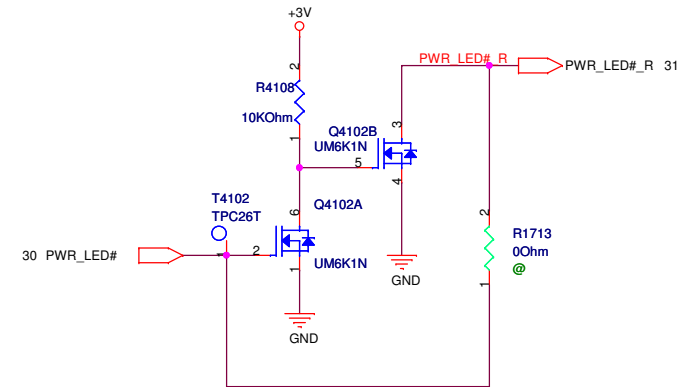
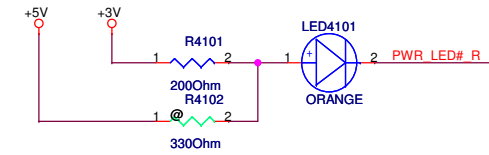

<Variant Name>

| | | | |
|------------------------------|--------------------|---------------------------------------|----------|
| ASUS | | Title :Switch Button & LED | |
| ASUSTeK COMPUTER INC | | Engineer: N/A | |
| Size | Project Name | Rev | |
| B | K401J/K501J | 1.1 | |
| Date: Monday, March 09, 2009 | | Sheet | 41 of 96 |

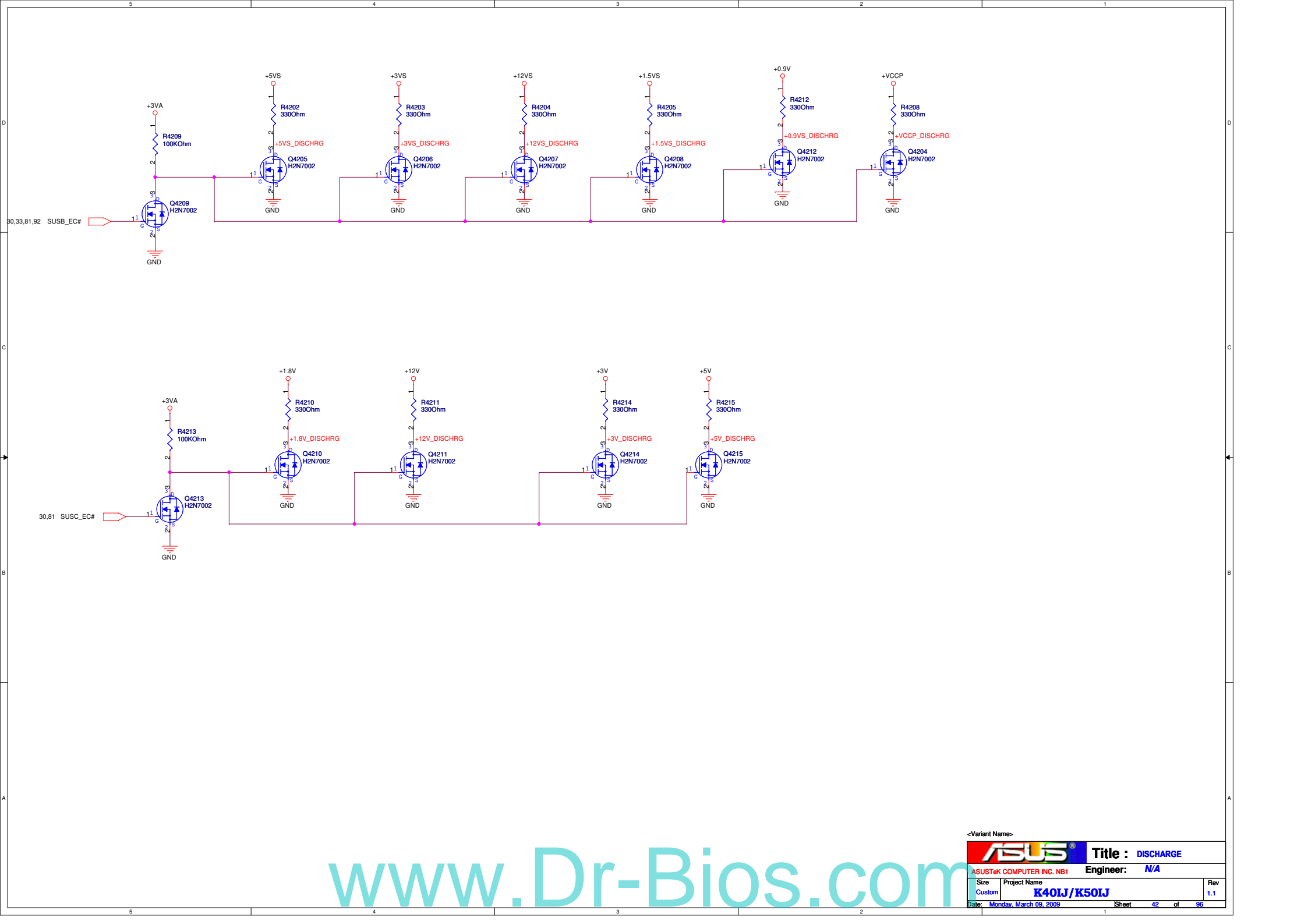

www.Dr-Bios.com

| | | |
|------------------------------|--------------|--------------------------|
| <Variant Name> | | |
| ASUS | | Title : DISCHARGE |
| ASUSTek COMPUTER INC. NB1 | | Engineer: N/A |
| Size | Project Name | Rev |
| Custom | K40J/K50J | 1.1 |
| Date: Monday, March 09, 2009 | Sheet | 42 of 96 |

5

4

3

2

1

D

D

C

C

B

B

A

A

www.Dr-Bios.com

| | | |
|---|--------------|-----------------------------|
| <Variant Name> | | |
|  | | Title : Schematic page name |
| ASUSTeK COMPUTER INC | | Engineer: N/A |
| Size | Project Name | Rev |
| Custom | K40IJ/K50IJ | 1.1 |
| Date: Monday, March 09, 2009 | Sheet 43 | of 96 |

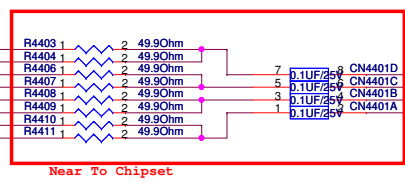
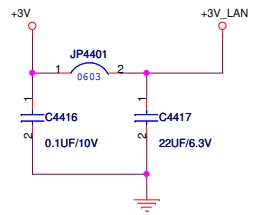
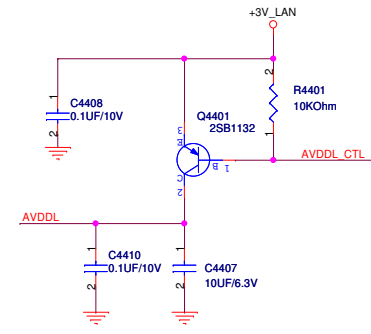
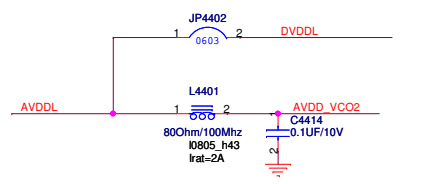
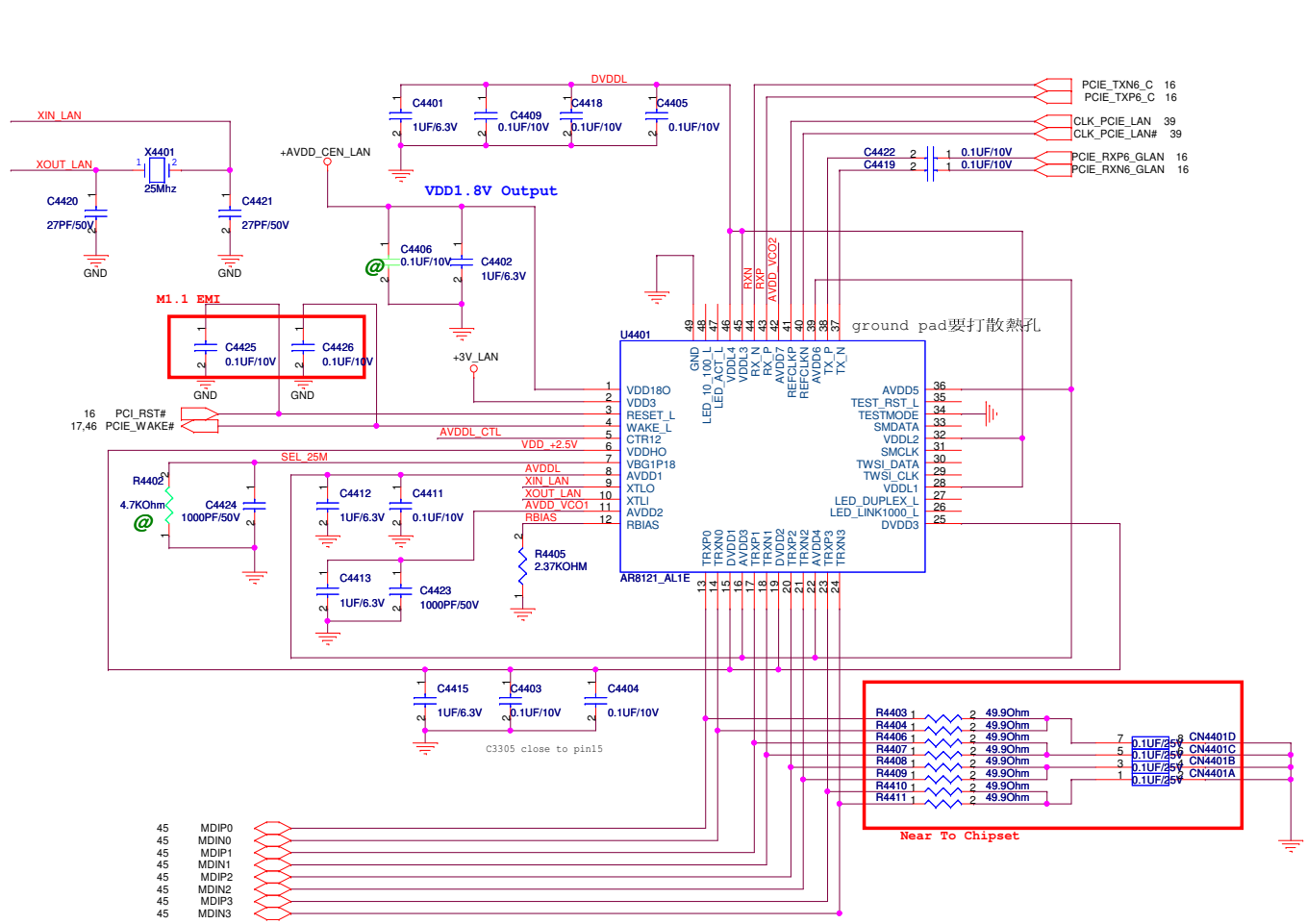

LAN CONN.

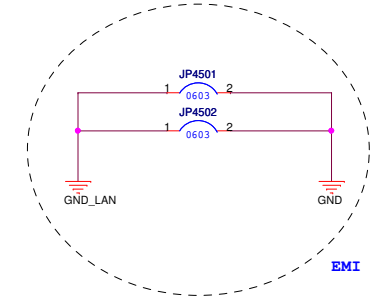
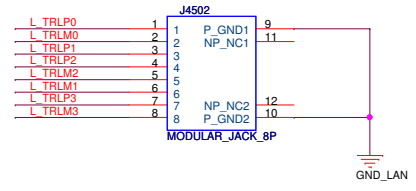
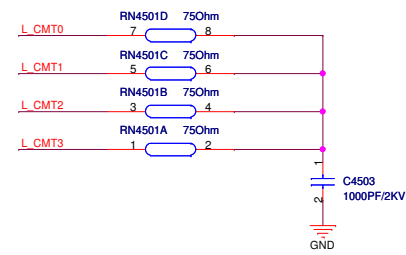
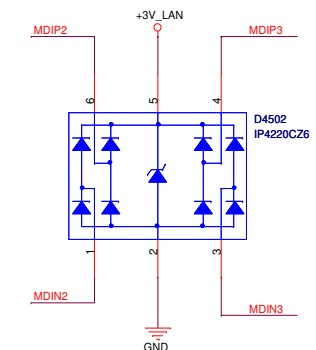
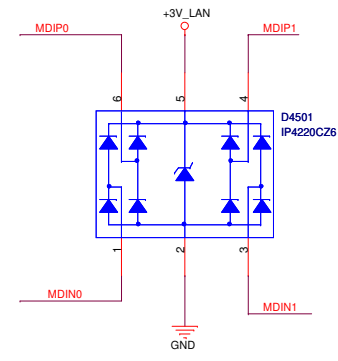
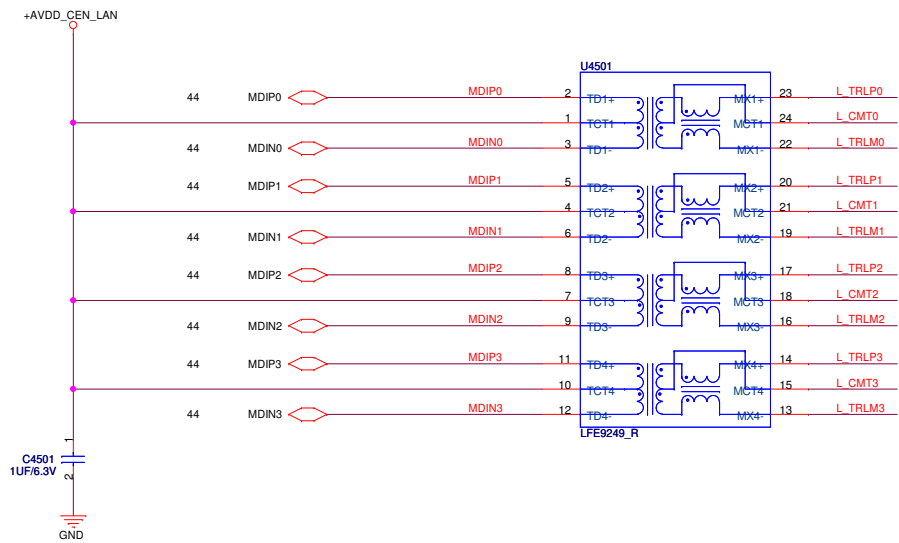

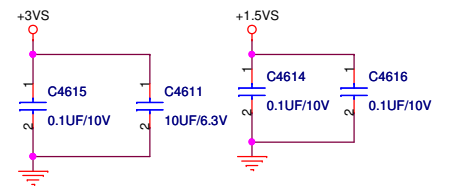
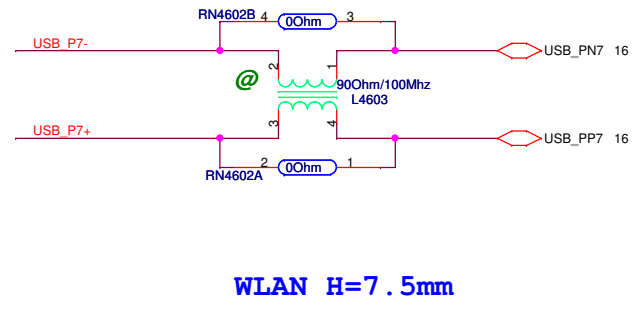
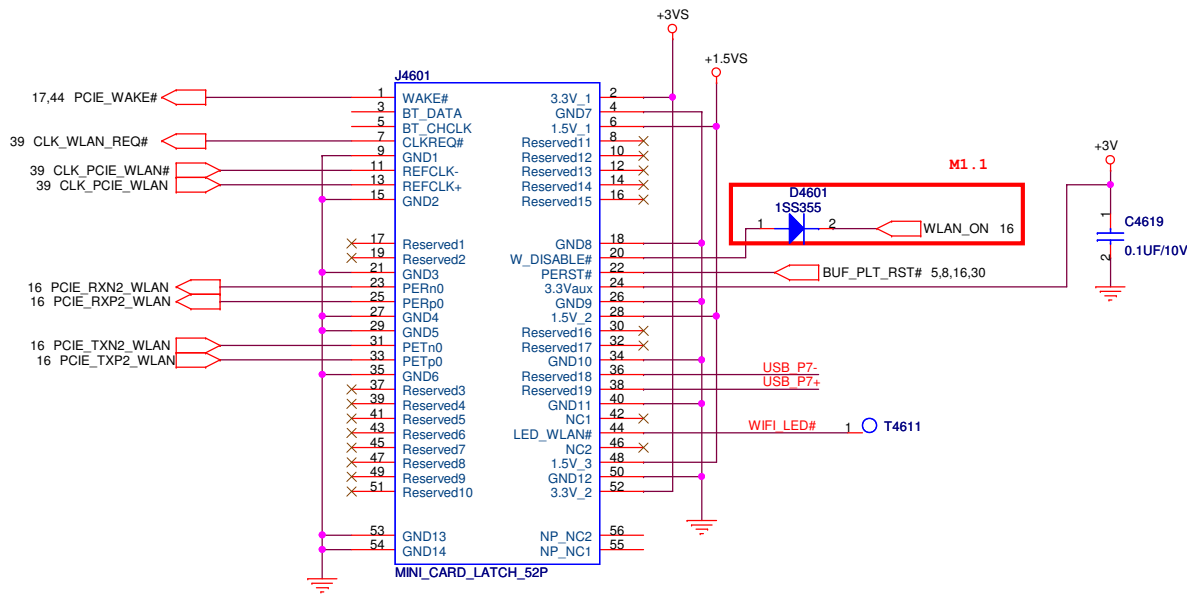

<Variant Name>

| | | | |
|------------------------------|--------------------|---------------------------------|----------|
| ASUS | | Title :Mini card_WLAN+3G | |
| ASUSTeK COMPUTER INC. NB1 | | Engineer: N/A | |
| Size | Project Name | | Rev |
| Custom | K40IJ/K50IJ | | 1.1 |
| Date: Monday, March 09, 2009 | | Sheet | 46 of 96 |

5

4

3

2

1

D

D

C

C

B

B

A

A

www.Dr-Bios.com

<Variant Name>

| | | | |
|---|--------------------|----------------------|----------|
|  | | Title : N/A | |
| ASUSTeK COMPUTER INC. NB1 | | Engineer: N/A | |
| Size | Project Name | | Rev |
| Custom | K40IJ/K50IJ | | 1.1 |
| Date: Monday, March 09, 2009 | | Sheet | 47 of 96 |

5

4

3

2

1

D

D

C

C

B

B

A

A

www.Dr-Bios.com

<Variant Name>

| | | | |
|---|--------------|-----------------------------|-------|
|  | | Title : Schematic page name | |
| ASUSTeK COMPUTER INC. NB1 | | Engineer: N/A | |
| Size | Project Name | Rev | |
| Custom | K40IJ/K50IJ | 1.1 | |
| Date: Monday, March 09, 2009 | Sheet | 48 | of 96 |

5

4

3

2

1

D

D

C

C

B

B

A

A

www.Dr-Bios.com

<Variant Name>

| | | | |
|---|--------------|------------------------------------|--|
|  | | Title : Schematic page name | |
| ASUSTeK COMPUTER INC. NB1 | | Engineer: N/A | |
| Size | Project Name | Rev | |
| Custom | K40IJ/K50IJ | 1.1 | |
| Date: Monday, March 09, 2009 | Sheet 49 | of 96 | |

5

4

3

2

1

D

D

C

C

B

B

A

A

www.Dr-Bios.com

| | | |
|---|----------------|-----------------------------|
| <Variant Name> | | |
|  | | Title : Schematic page name |
| ASUSTeK COMPUTER INC | | Engineer: N/A |
| Size | Project Name | Rev |
| Custom | K40IJ/K50IJ | 1.1 |
| Date: Monday, March 09, 2009 | Sheet 50 of 96 | |

5

4

3

2

1

D

D

C

C

B

B

A

A

www.Dr-Bios.com

<Variant Name>

| | | | |
|---|--------------------|----------------------|-------|
|  | | Title : N/A | |
| ASUSTeK COMPUTER INC. NB1 | | Engineer: N/A | |
| Size | Project Name | Rev | |
| Custom | K40IJ/K50IJ | 1.1 | |
| Date: Monday, March 09, 2009 | Sheet | 51 | of 96 |

5

4

3

2

1

D

D

C

C

B

B

A

A

www.Dr-Bios.com

<Variant Name>

| | | | |
|---|--------------------|----------------------|-------|
|  | | Title : N/A | |
| ASUSTeK COMPUTER INC. NB1 | | Engineer: N/A | |
| Size | Project Name | | Rev |
| Custom | K40IJ/K50IJ | | 1.1 |
| Date: Monday, March 09, 2009 | Sheet | 52 | of 96 |

USB Cardreader

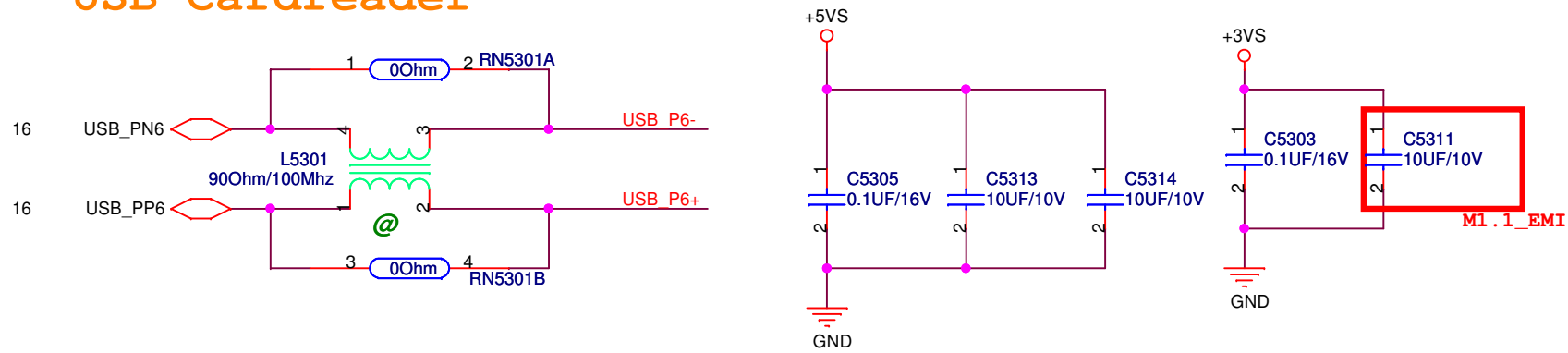

SATA HDD

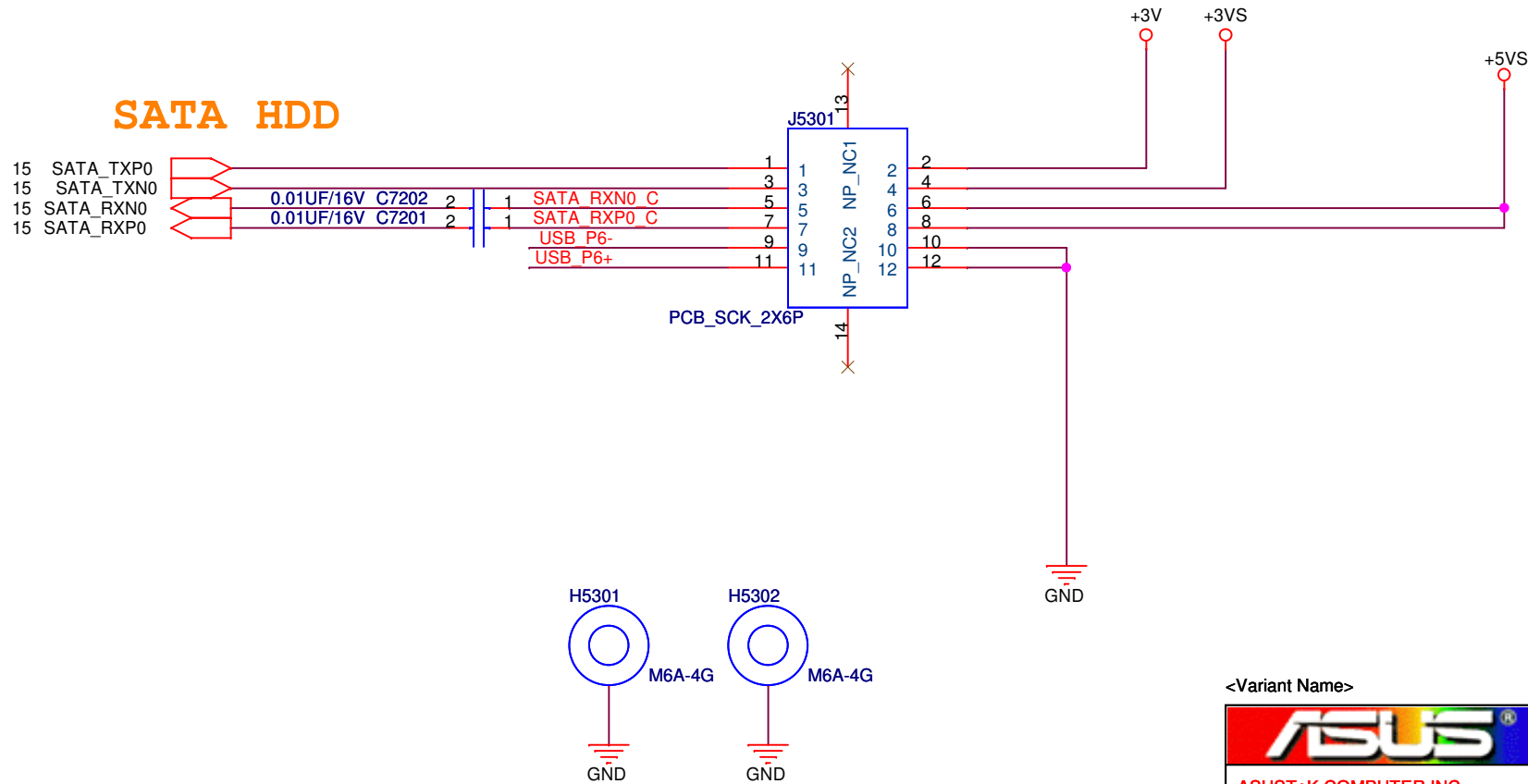

<Variant Name>

| | | |
|-------------------------------------|------------------------------------|---|
| ASUS | | Title :SATA_HDD & Cardreader |
| ASUSTeK COMPUTER INC | | Engineer: N/A |
| Size Custom | Project Name K40IJ/K50IJ | Rev 1.1 |
| Date: Monday, March 09, 2009 | Sheet 53 of 96 | |

5

4

3

2

1

D

D

C

C

B

B

A

A

<Variant Name>

| | | |
|---|------------------------------------|------------------------------|
|  | | Title : NEWCARD |
| ASUSTeK COMPUTER INC. NB1 | | Engineer: N/A |
| Size B | Project Name K40IJ/K50IJ | Rev 1.1 |
| Date: Monday, March 09, 2009 | | Sheet 54 of 96 |

5

4

3

2

1

D

D

C

C

B

B

A

A

www.Dr-Bios.com

<Variant Name>

| | | | |
|---|--------------------|------------------------------------|-------|
|  | | Title : Schematic page name | |
| ASUSTeK COMPUTER INC | | Engineer: N/A | |
| Size | Project Name | Rev | |
| Custom | K40IJ/K50IJ | 1.1 | |
| Date: Monday, March 09, 2009 | Sheet | 55 | of 96 |

| | | |
|---|------------------------------------|----------------------------------|
| <Variant Name> | | |
|  | | Title : HDA level shifter |
| ASUSTeK COMPUTER INC. NB1 | | Engineer: N/A |
| Size Custom | Project Name K40LJ/K50LJ | Rev 1.1 |
| Date: Monday, March 09, 2009 | | Sheet 56 of 96 |

HDMI WtoB Connector

HDCP ROM

<Variant Name>

| | | |
|---|---------------------|------------------------------|
|  | | Title : iHDMI |
| ASUSTeK COMPUTER INC. NB1 | | Engineer: N/A |
| Size B | Project Name | Rev 1.1 |
| Date: Monday, March 09, 2009 | | Sheet 57 of 96 |

5

4

3

2

1

D

D

C

C

B

B

A

A

www.Dr-Bios.com

| | | |
|---|----------------|-----------------------------|
| <Variant Name> | | |
|  | | Title : Schematic page name |
| ASUSTeK COMPUTER INC. NB1 | | Engineer: N/A |
| Size | Project Name | Rev |
| Custom | K40IJ/K50IJ | 1.1 |
| Date: Monday, March 09, 2009 | Sheet 58 of 96 | |

5

4

3

2

1

D

D

C

C

B

B

A

A

www.Dr-Bios.com

<Variant Name>

| | | | |
|---|--------------------|------------------------------------|-------|
|  | | Title : Schematic page name | |
| ASUSTeK COMPUTER INC. NB1 | | Engineer: N/A | |
| Size | Project Name | Rev | |
| Custom | K40IJ/K50IJ | 1.1 | |
| Date: Monday, March 09, 2009 | Sheet | 59 | of 96 |

5

4

3

2

1

D

D

C

C

B

B

A

A

www.Dr-Bios.com

| | | |
|---|-----------------------------|-----------------------------|
| <Variant Name> | | |
|  | | Title : Schematic page name |
| ASUSTeK COMPUTER INC | | Engineer: N/A |
| Size Custom | Project Name K40IJ/K50IJ | Rev 1.1 |
| Date: Monday, March 09, 2009 | Sheet 60 of 96 | |

5

4

3

2

1

D

D

C

C

B

B

A

A

www.Dr-Bios.com

<Variant Name>

| | | | |
|---|--------------------|------------------------------------|-------|
|  | | Title : Schematic page name | |
| ASUSTeK COMPUTER INC | | Engineer: N/A | |
| Size | Project Name | Rev | |
| Custom | K40IJ/K50IJ | 1.1 | |
| Date: Monday, March 09, 2009 | Sheet | 61 | of 96 |

USB IO Board

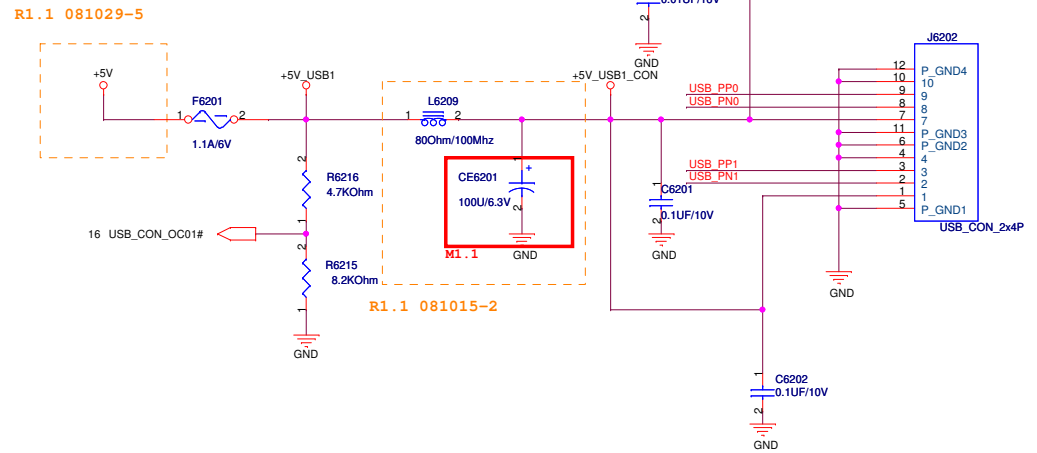
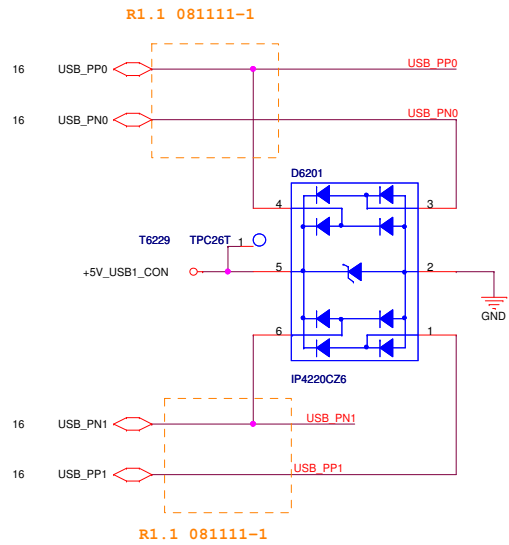
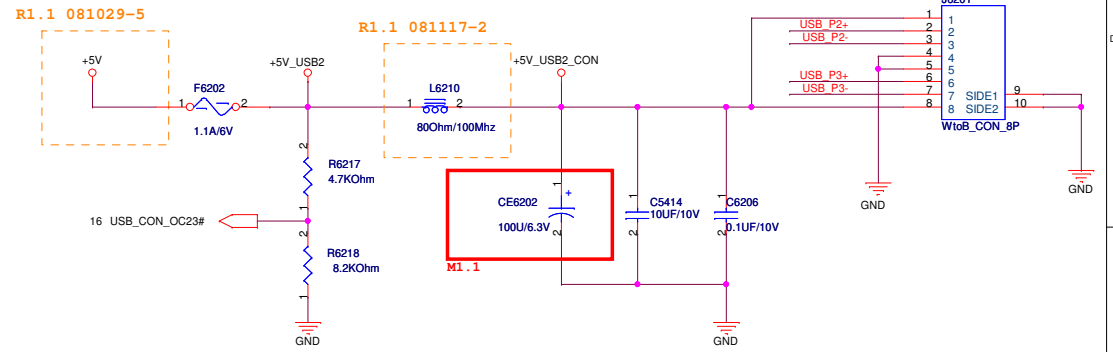
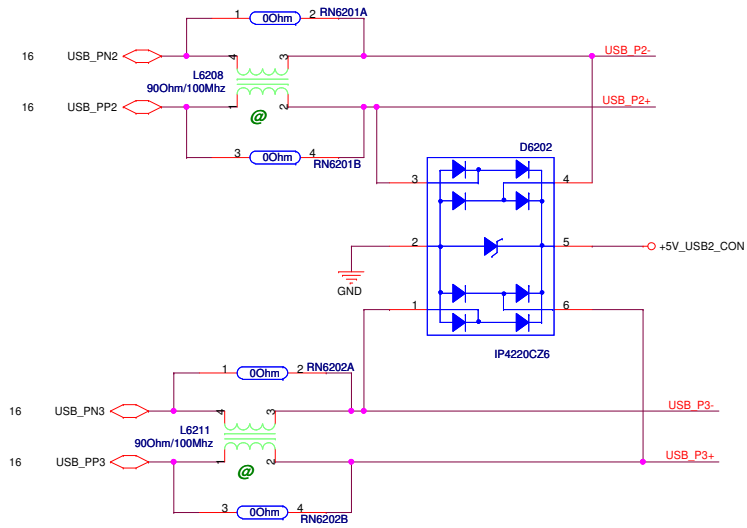

www.Dr-Bios.com

| | | | | | |
|------------------------------|--------------|---------------|--|-------------------------|--|
| -Variant Name- | | ASUS | | Title : USB CONN | |
| ASUSTek COMPUTER INC | | Engineer: N/A | | | |
| Size | Project Name | Custom | | Rev 1.1 | |
| Date: Monday, March 09, 2009 | | K40IJ/K50IJ | | Sheet 62 of 96 | |

5

4

3

2

1

D

D

C

C

B

B

A

A

www.Dr-Bios.com

| | | |
|---|--------------|-----------------------------|
| <Variant Name> | | |
|  | | Title : Schematic page name |
| ASUSTeK COMPUTER INC | | Engineer: N/A |
| Size | Project Name | Rev |
| Custom | K40IJ/K50IJ | 1.1 |
| Date: Monday, March 09, 2009 | Sheet | 63 of 96 |

5

4

3

2

1

D

D

C

C

B

B

A

A

www.Dr-Bios.com

| | | |
|---|--------------|-----------------------------|
| <Variant Name> | | |
|  | | Title : Schematic page name |
| ASUSTeK COMPUTER INC. NB1 | | Engineer: N/A |
| Size | Project Name | Rev |
| Custom | K40IJ/K50IJ | 1.1 |
| Date: Monday, March 09, 2009 | Sheet 64 | of 96 |

5

4

3

2

1

D

D

C

C

B

B

A

A

www.Dr-Bios.com

<Variant Name>

| | | | |
|---|--------------------|------------------------|-------|
|  | | Title : SPI ROM | |
| ASUSTeK COMPUTER INC. NB1 | | Engineer: N/A | |
| Size | Project Name | | Rev |
| Custom | K40IJ/K50IJ | | 1.1 |
| Date: Monday, March 09, 2009 | Sheet | 65 | of 96 |

5

4

3

2

1

D

D

C

C

B

B

A

A

www.Dr-Bios.com

<Variant Name>

| | | | |
|---|--------------------|----------------------|-------|
|  | | Title : LED | |
| ASUSTeK COMPUTER INC | | Engineer: N/A | |
| Size | Project Name | Rev | |
| Custom | K40IJ/K50IJ | 1.1 | |
| Date: Monday, March 09, 2009 | Sheet | 66 | of 96 |

LPC DEBUG PORT

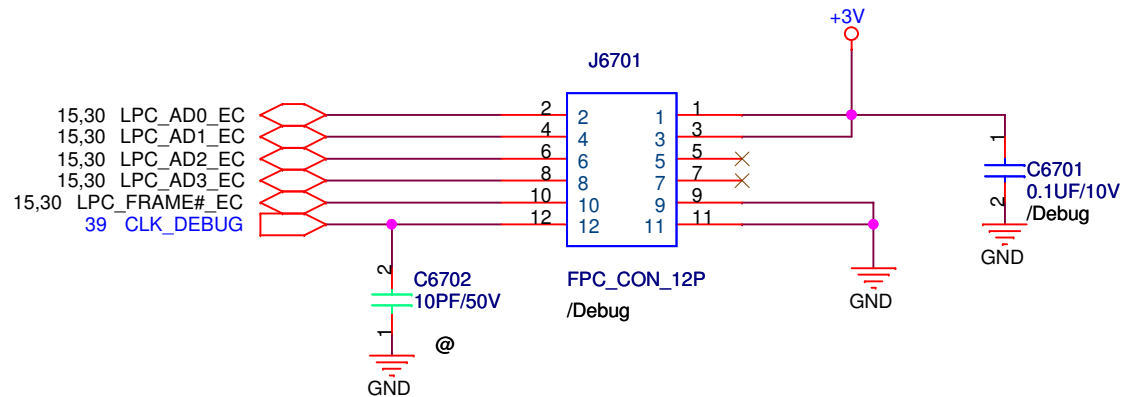

<Variant Name>

| | | |
|------------------------------|-----------------------------|---------------------------|
| ASUS | | Title : DEBUG CONN |
| ASUSTeK COMPUTER INC | | Engineer: N/A |
| Size A | Project Name K40IJ/K50IJ | Rev 1.1 |
| Date: Monday, March 09, 2009 | | Sheet 67 of 96 |

www.Dr-Bios.com

DC IN

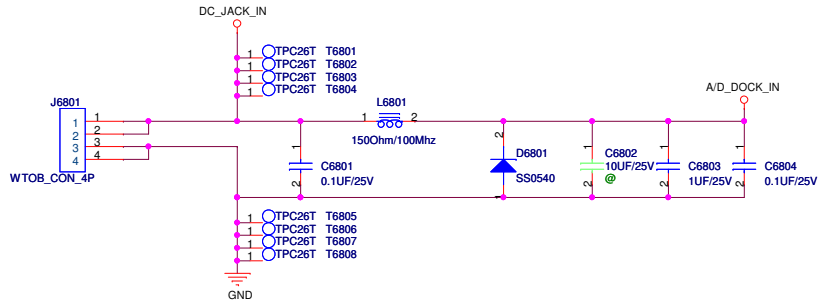

BAT IN

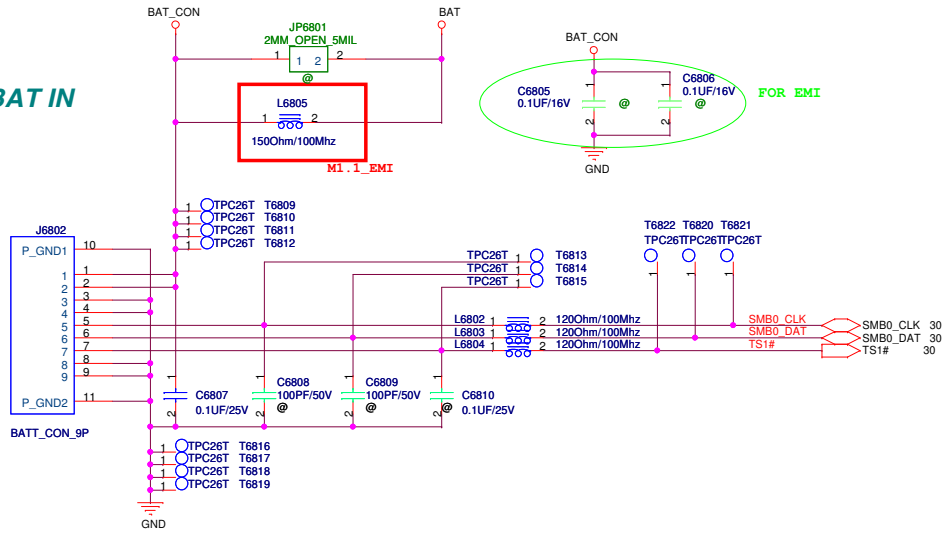

Note: When plug in or out the battery, it may cause a spike to damage EC and gas gauge. It needs to add varistors to protect those pins.

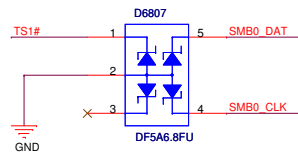

Without Battery & Pull out Adapter

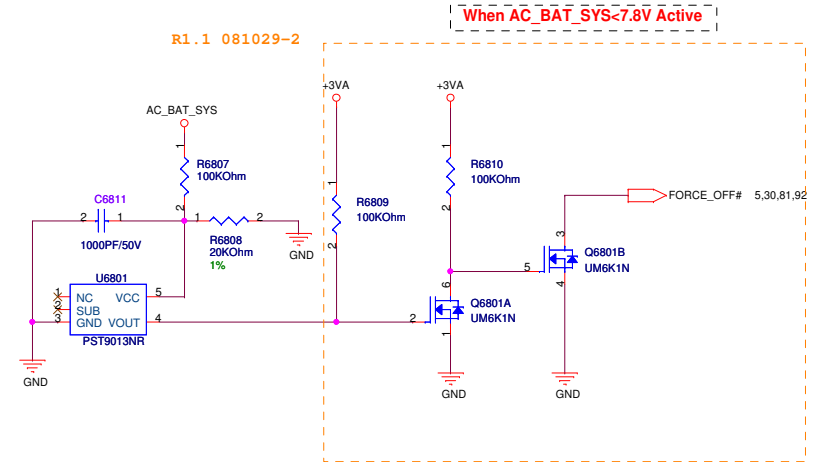

5

4

3

2

1

D

D

C

C

B

B

A

A

www.Dr-Bios.com

| | | |
|---|--------------|-----------------------------|
| <Variant Name> | | |
|  | | Title : Schematic page name |
| ASUSTeK COMPUTER INC | | Engineer: N/A |
| Size | Project Name | Rev |
| Custom | K40IJ/K50IJ | 1.1 |
| Date: Monday, March 09, 2009 | Sheet 69 | of 96 |

5

4

3

2

1

D

D

C

C

B

B

A

A

www.Dr-Bios.com

<Variant Name>

| | | | |
|---|--------------------|----------------------------|-------|
|  | | Title : Debug CONN. | |
| ASUSTeK COMPUTER INC | | Engineer: N/A | |
| Size | Project Name | | Rev |
| Custom | K40IJ/K50IJ | | 1.1 |
| Date: Monday, March 09, 2009 | Sheet | 70 | of 96 |

5

4

3

2

1

D

D

C

C

B

B

A

A

www.Dr-Bios.com

<Variant Name>

| | | | |
|---|--------------|-----------------------------|-------|
|  | | Title : Schematic page name | |
| ASUSTeK COMPUTER INC | | Engineer: N/A | |
| Size | Project Name | Rev | |
| Custom | K40IJ/K50IJ | 1.1 | |
| Date: Monday, March 09, 2009 | Sheet | 71 | of 96 |

ODD

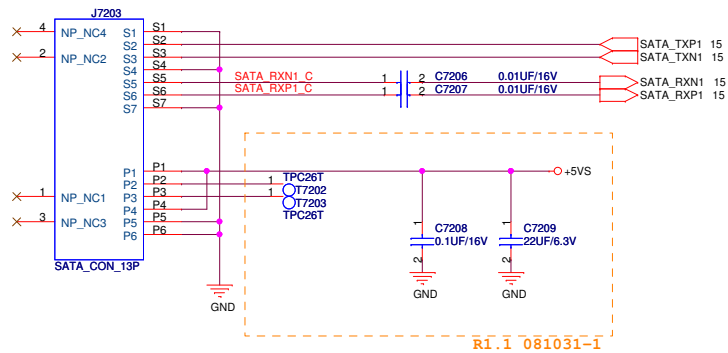

5

4

3

2

1

D

D

C

C

B

B

A

A

www.Dr-Bios.com

<Variant Name>

| | | | |
|---|--------------------|----------------------|----------|
|  | | Title : N/A | |
| ASUSTeK COMPUTER INC. NB1 | | Engineer: N/A | |
| Size | Project Name | | Rev |
| Custom | K40IJ/K50IJ | | 1.1 |
| Date: Monday, March 09, 2009 | | Sheet | 73 of 96 |

Hole-A

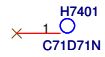

Hole-B

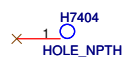
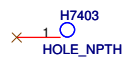
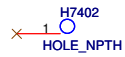

Hole-C

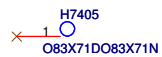

Hole-D

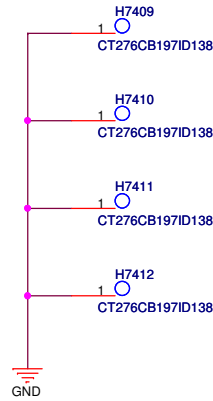

Hole-E

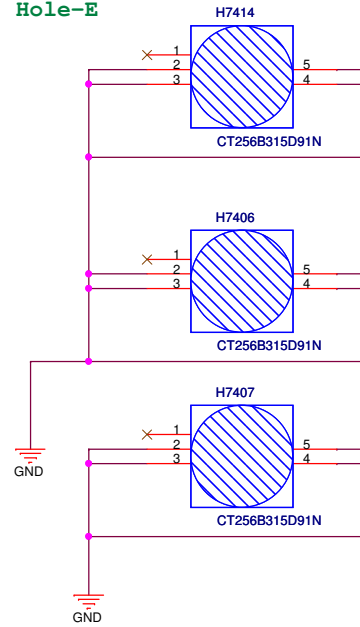

Hole-F

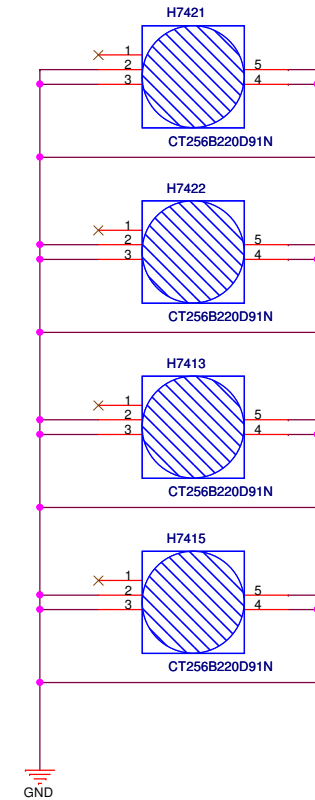
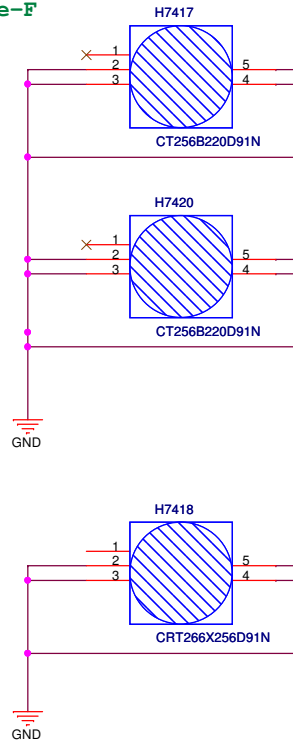

Spring

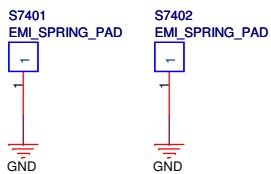

<Variant Name>

| | | | |
|-------------------------------------|------------------------------------|---------------------------|----------|
| | | Title : Hole | |
| ASUSTeK COMPUTER INC | | Engineer: Leon Guo | |
| Size B | Project Name K40IJ/K50IJ | Rev 1.1 | |
| Date: Monday, March 09, 2009 | | Sheet | 74 of 96 |

5

4

3

2

1

D

D

C

C

B

B

A

A

<Variant Name>

| | | | |
|---|--------------|----------------------|----------|
|  | | Title : N/A | |
| ASUSTeK COMPUTER INC | | Engineer: N/A | |
| Size | Project Name | Rev | |
| A | K40IJ/K50IJ | 1.1 | |
| Date: Monday, March 09, 2009 | | Sheet | 75 of 96 |

www.Dr-Bios.com

5

4

3

2

1

5

4

3

2

1

D

D

C

C

B

B

A

A

<Variant Name>

| | |
|---|-----------------------------|
|  | Title : EXPRESS GATE |
|---|-----------------------------|

| | |
|----------------------|----------------------|
| ASUSTeK COMPUTER INC | Engineer: N/A |
|----------------------|----------------------|

| | | |
|----------------|--------------------------------------|------------|
| Size Custom | Project Name K40IJ / K50IJ | Rev 1.1 |
|----------------|--------------------------------------|------------|

| | |
|------------------------------|----------------|
| Date: Monday, March 09, 2009 | Sheet 76 of 96 |
|------------------------------|----------------|

www.Dr-Bios.com

```

R1_1 Modify List
P04_Q0402,R0401 No mount
P36_INT_MIC Change
P37_J2704 speaker_H_SPK1+/H_SPK1-/H_SPKR+/H_SPKR- Signal modify,Del R3732
P05_C80502,C0528,31,32,33,36,43 NO-Stuff
P07_C0702 NO-Stuff
P08_R0813 NO-Stuff,R0815/R0816 10K OHM change to 0 OHM(E/R Check if ok change to J8112 to J8110)
R0817 100 OHM Change to Short JP
P12_C1223,C1245 100F/10V(1206) change to 100F/6.3V(0805) for reduce component count
P24_Add On-board memory to 2G
P30_change "BATSEL_28#" to "BATSEL_0"
change "BATSEL_38#" to "BATSEL_1"
Merge R3020,21,27,29 to array resistor
P36_C3616 Y5V change to X7R for reduce component count
P37_C3720 Y5V change to X7R for reduce component count
P39_Delete RN3901,RN3902
P44_Change LAN Chip from RTL8111DL to AN8121
P09_R0910,11,12 change to RN0901 array package
P30_R3002,03,05,28 change package
P18_Add C1843,C3324,C2203,C4425,C4426 for EMI
Del R3506
Change ReferenceC7213,03,05,11 to C53013,03,05,11
P16_For EMI CMOS form Port 4 change to Port 8
P46_C86202 Change package
P11_C1125,26,30 0.22UF change to 1UF cost down
P3601_Reserve C3601,R3604 for Vendor request
P31_L3102,03 change to R3103,02
Add JP1502 del R1511
Del R0918,R0919 add RN0902
P39_Del R3946 ,add RN3910
P04_C0401,02,03 add for EMI
P04_C0402 add for EMI

1/15
change J8112 to J8112
change J8112 to J8110
change J8113 to J8113
change J8114 to J8114
change J8115 to J8115
change J8103 to J8103
change J8106 to J8106
change J8109 to J8109
change J8111 to J8111
change J8105 to J8105

page 82
change JP8203 to J8203

page 83
change JP8303 to J8203
change JP8304 to J8304

page 84
add JP8402
Change U8401 to APL5930 from APL5913

Page 88
change JP8805 to J8805

1/14
page 80
change Q8001 and Q8003 to 07G005A15011 from 07G005C34010.
change Q8002 and Q8004 to 07G005B71010 from 07G005C33010.
stuff C8003

page 83
change R8304 to 10G212150214030 from 10G212750114010.

1/08
Change all 2MM_SHORT_SMI1 to 2MM_OPEN_SMI1(s00496)

page 81
change "L7020_DLL1" to "8206_DLL1".

page 88
add L8802 between BAT and BAT_CON
change R8823.2 to GND from SGND_CHG.
change "BATSEL_28#" to "BATSEL_0"
change "BATSEL_38#" to "BATSEL_1"

01/07
Delete Empty Page 85,86,87,89,90

Page 80
Change R8010, R8013, R8020, R8035, R8040, R8046 to temp.4759_ch01 from 10G212000004010
Change C8003, C8017 to Unmount
Delete R8050

Page 81
Change R8116, R8119, R8125, R8110, R8107 to temp.4759_ch01 from 10G212000004010
Delete R8102, R8118
Change D8103 to 07G004069020 from 07G001007230

Page 82
Change D8201 to 07G004069020 from 07G001007230

Page 83
Change D8301 to 07G004069020 from 07G001007230

Page 84
Delete R8404
Delete Netname 5913_VCNFL

Page 88
Change D8804 to 07G004069020 from 07G001007230

Page 91
Change R9105, R9108 to 10G252100314030 from 10G212100314030

12/31
page 80
change Q8002, Q8004 to 07G005C35010 from 07G005C33010
change U8001 to 06G008425013 from 06G008692010
change R8026 to 10G212680114010 from 10G212953114010

12/26
page 81
change CE8101, CE8102 to 11G08D21075A from 11G09X222755.

page 82
delete Q8203.
delete C8207.
change CE8202 to 11G08D2227D1 from 11G09X222755.
change U8201.7, U8201.15, R8205.1 to SGND.

page 83
change CE8301 to 11G08D2227D1 from 11G09X222755.
change JP8301 to 2MM.

page 88
change U8801.6 net name to CHG -TNE3 from CHG_COMP3.
change C8806, C8809 to 11G233110412030 from 11G23210412360.
change Q8802, Q8803 PCB Footprint to soic_8p_50_197x236.

page 91
change R9107 to 10G212220214030 from 10G213220213010.
page80
add net name "SNB_PH1" between R8020 and C8040
add net name "SNB_PH2" between R8021 and C8041
change C8040 to 11G232115214320 from 11G233115214320.
change C8041 to 11G232115214320 from 11G233115214320.

page 84
change JP8402.1 connection to +1.8V from +1.8V0
add net name "5930_VIN" on U8401.5 and U8401.9
change net name "5913_FB" to "5930_FB" on U8401.2

page 88
add net name "SNB_CHG" between R8804 and C8803
add net name "CHG_BST" between R8810 and C8802
change C8803 to 11G232115214320 from 11G233115214320.

```

```

P05_Del JP0501
P16_Add R1602
P33_Add R3308,R3309

```



5

4

3

2

1

D

D

C

C

B

B

A

A

www.Dr-Bios.com

| | | |
|---|----------------|-----------------------------|
| <Variant Name> | | |
|  | | Title : Schematic page name |
| ASUSTeK COMPUTER INC | | Engineer: N/A |
| Size | Project Name | Rev |
| Custom | K40IJ/K50IJ | 1.1 |
| Date: Monday, March 09, 2009 | Sheet 78 of 96 | |

www.Dr-Bios.com

| | | |
|---|------------------------------|-----------------------------|
| <Variant Name> | | |
|  | | Title : Schematic page name |
| ASUSTeK COMPUTER INC | Engineer: | N/A |
| Size Custom | Project Name K50II | Rev 1.1 |
| Date: Monday, March 09, 2009 | Sheet | 79 of 96 |

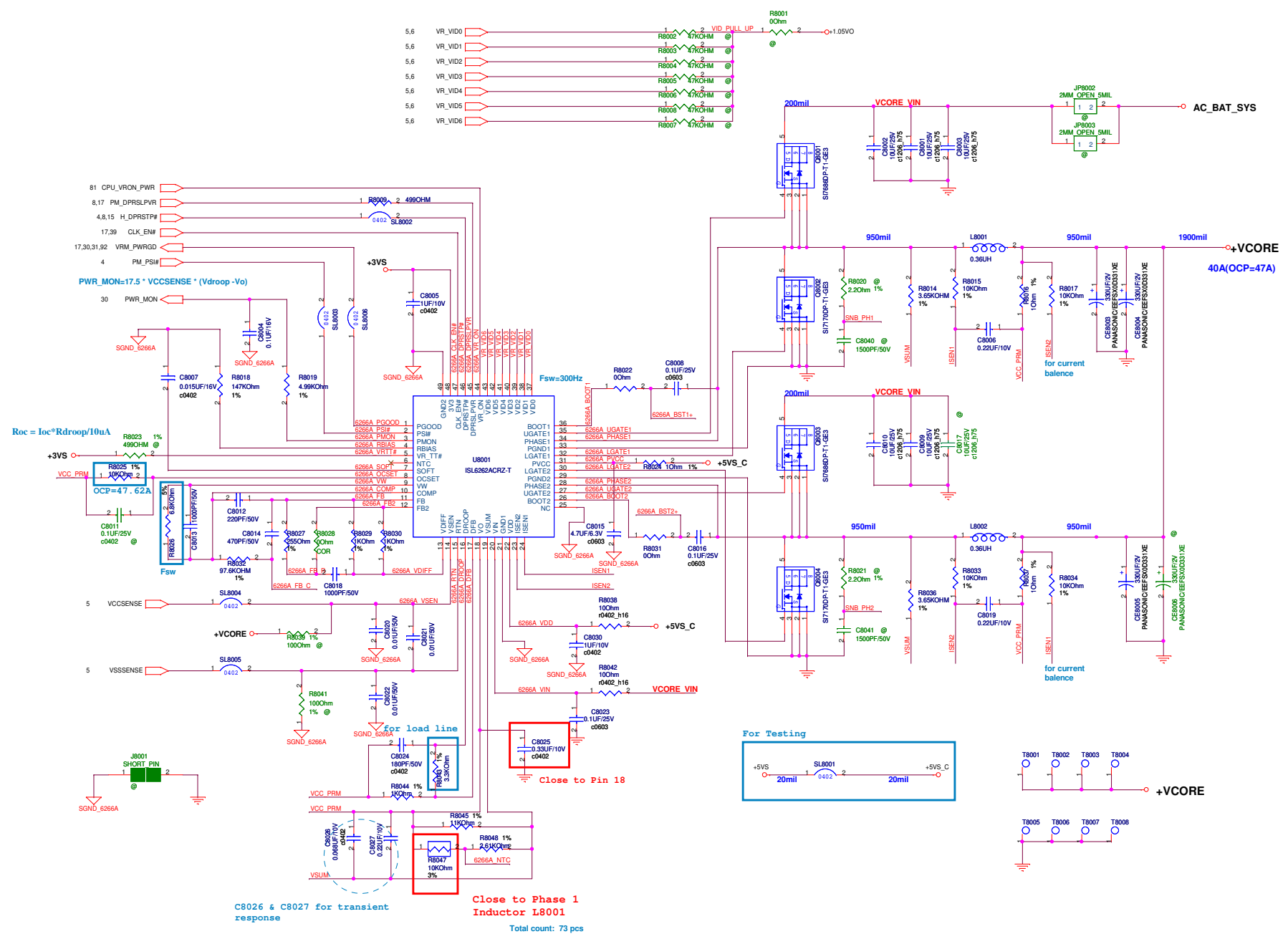

$R_{oc} = I_{oc} \cdot R_{droop} / 10uA$

$OCP = 47.62A$

C8026 & C8027 for transient response
 Total count: 73 pcs

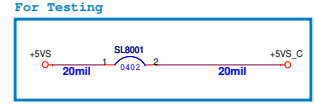

| | | | |
|------------------------------|--------------|------------------|-------|
| ASUS | | Title : +VCORE | |
| ASUSTeK COMPUTER INC. NB1 | | Engineer: Morris | |
| Size | Project Name | Rev | |
| Custom | K50 | 1.0 | |
| Date: Monday, March 09, 2009 | Sheet | 80 | of 96 |

HS MOS Second source IRF8714
 LS MOS Second source IRF8736

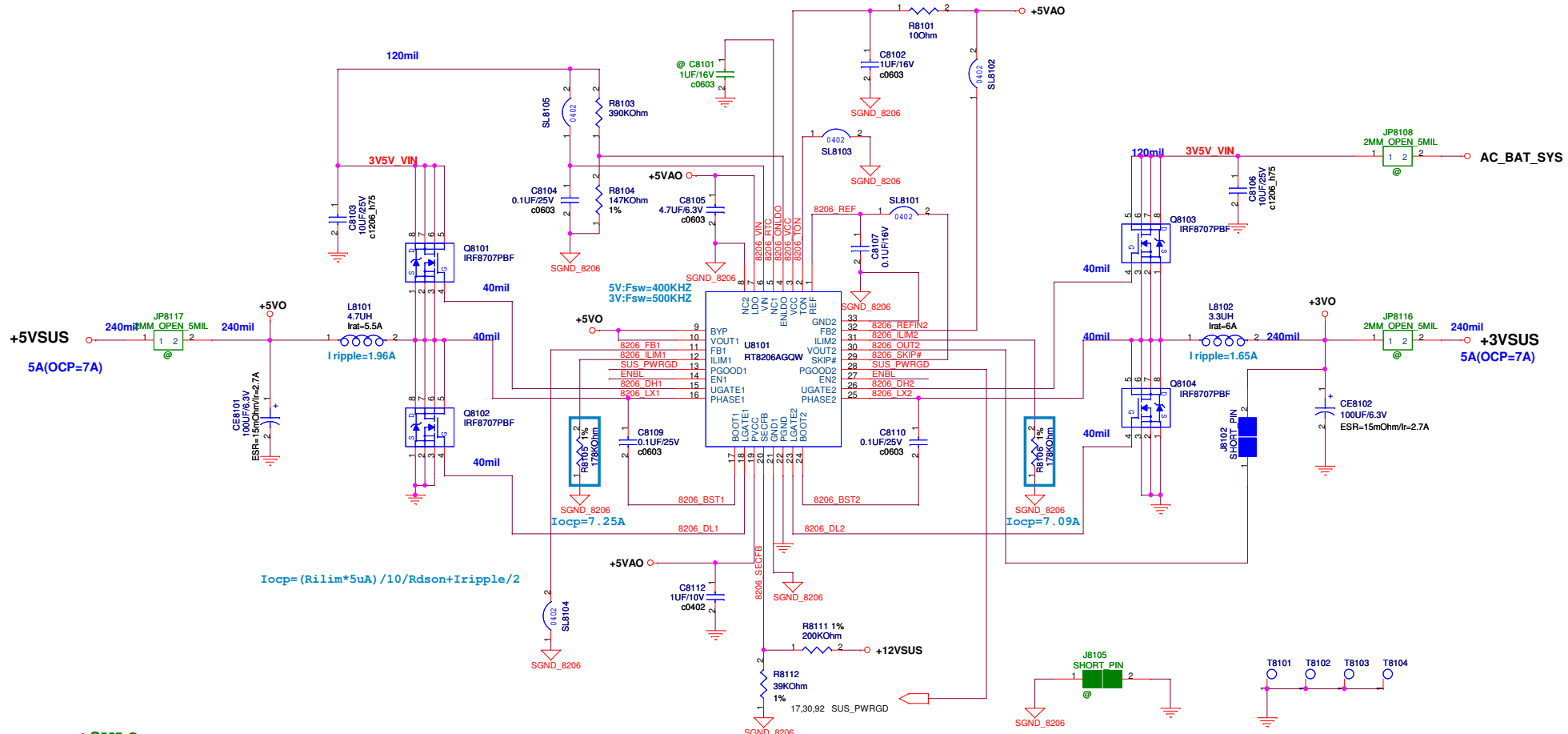

$$I_{ocp} = (R_{ilim} * 5\mu A) / 10 / R_{ds(on)} + I_{ripple} / 2$$

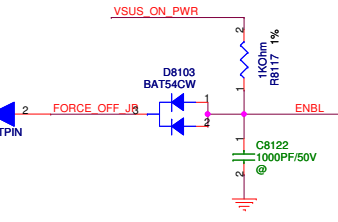
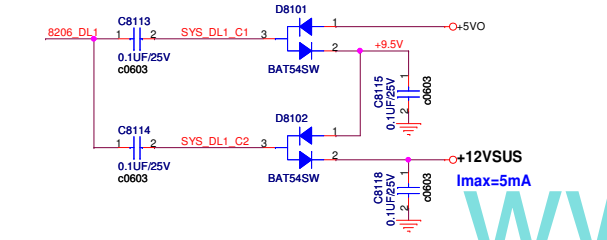
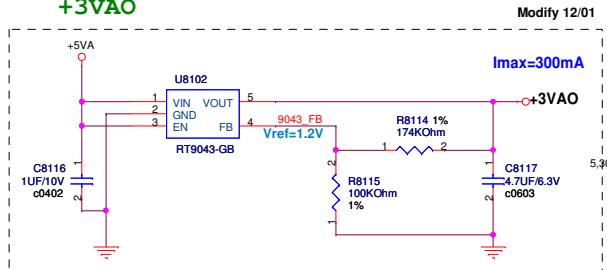

FOR POWER TEST

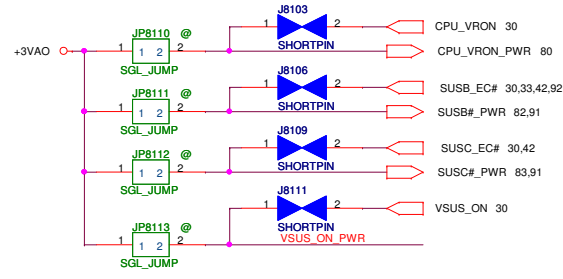

Total count: 44 pcs

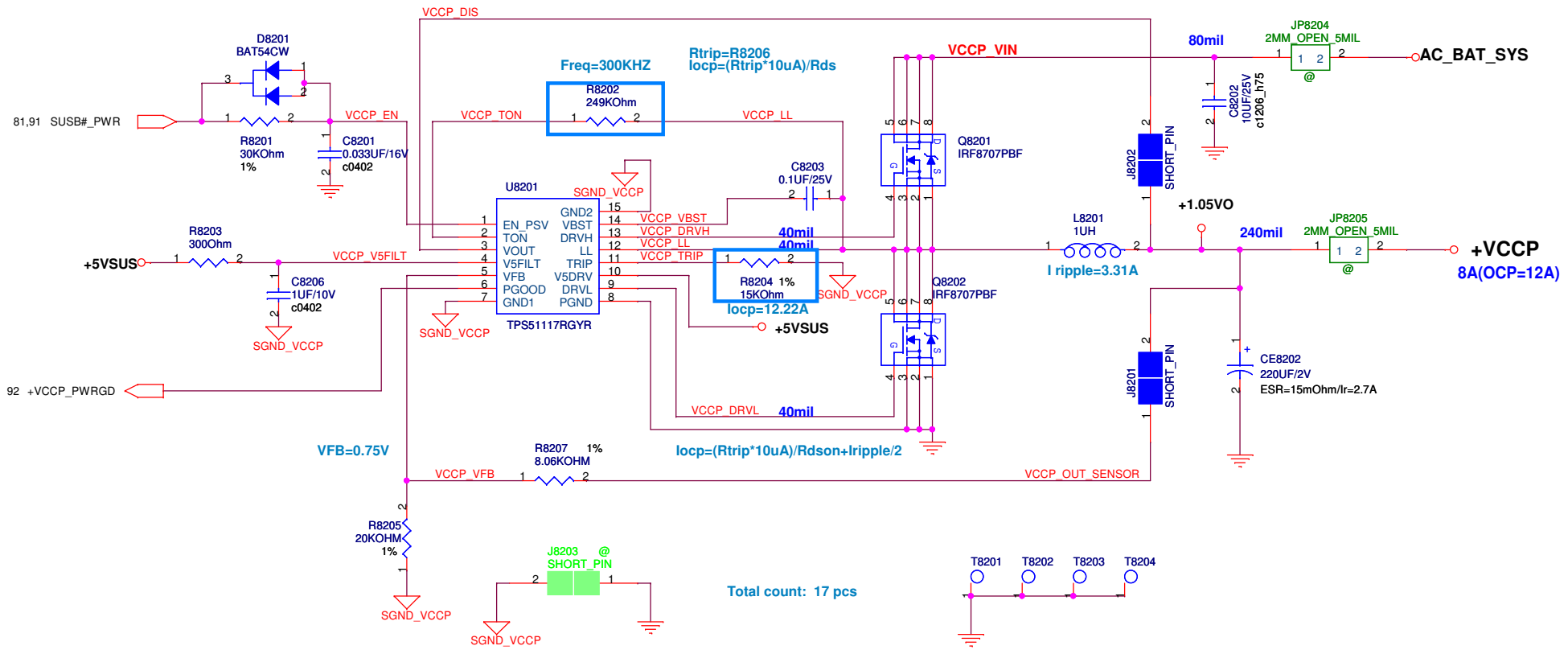

<Variant Name>

| | | | |
|------------------------------|--------------|-------------------------------|--|
| ASUS | | Title :POWER_I/O_+VCCP | |
| ASUSTeK COMPUTER INC. NB | | Engineer: Morris | |
| Size | Project Name | Rev | |
| Custom | K50 | 1.0 | |
| Date: Monday, March 09, 2009 | Sheet 82 | of 96 | |

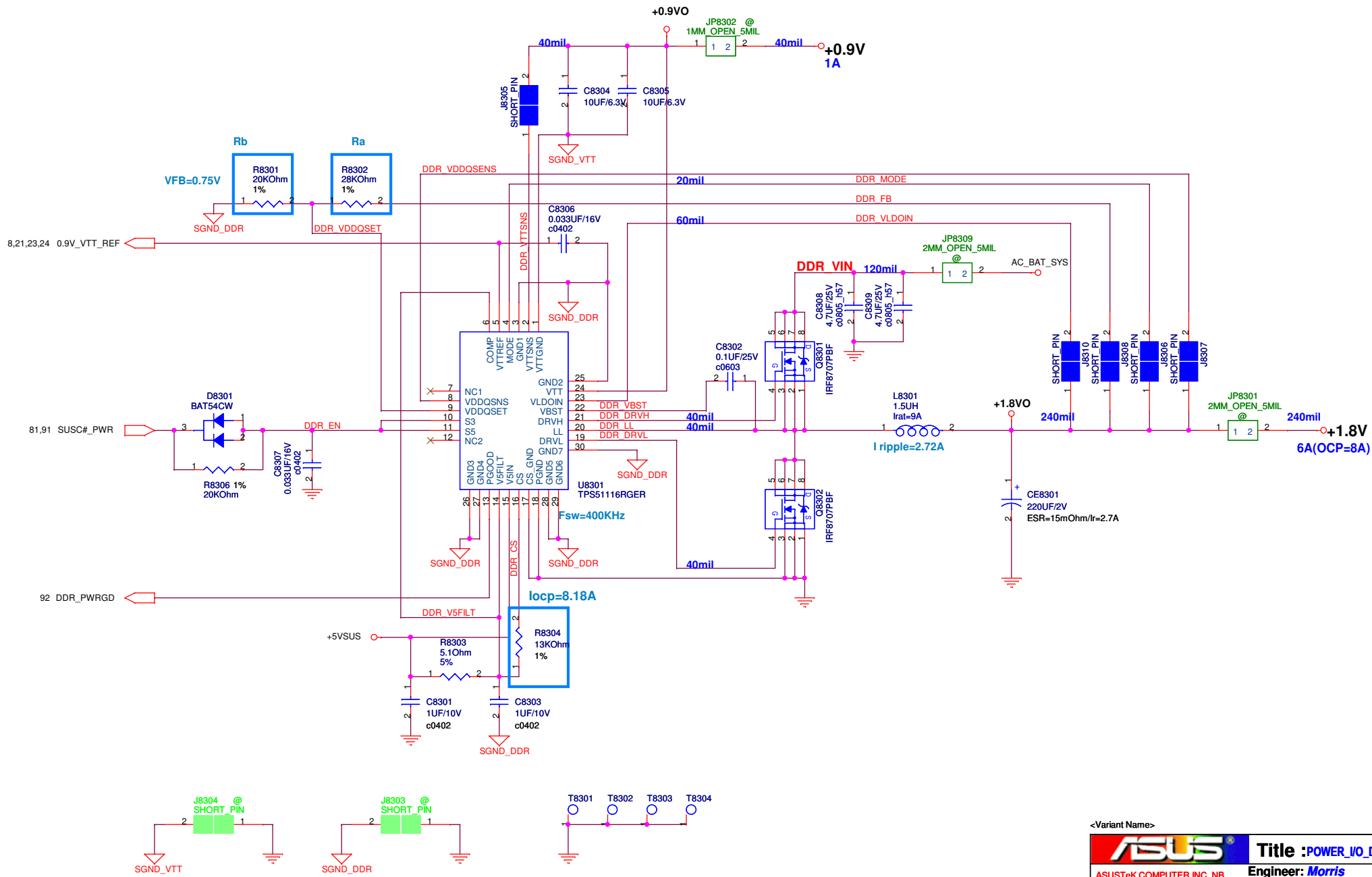

<Variant Name>

| | | | |
|------------------------------|----------------------------|-----------------------------|----------|
| | | Title :POWER_I/O_DDR | |
| ASUSTeK COMPUTER INC. NB | | Engineer: Morris | |
| Size B | Project Name K50 | Rev 1.0 | |
| Date: Monday, March 09, 2009 | | Sheet | 83 of 96 |

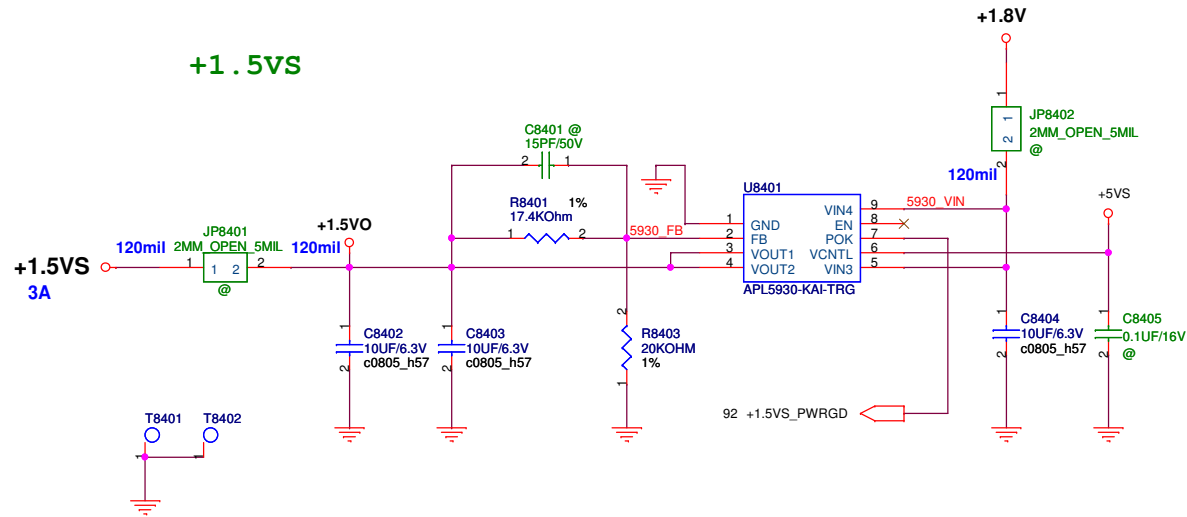

Total count: 7 pcs

<Variant Name>

| | | | |
|------------------------------|--------------|-------------------------|----------|
| | | Title : POWER_IO_+1.5VS | |
| ASUSTeK COMPUTER INC. NB | | Engineer: Morris | |
| Size | Project Name | | Rev |
| B | K50 | | 1.0 |
| Date: Monday, March 09, 2009 | | Sheet | 84 of 96 |

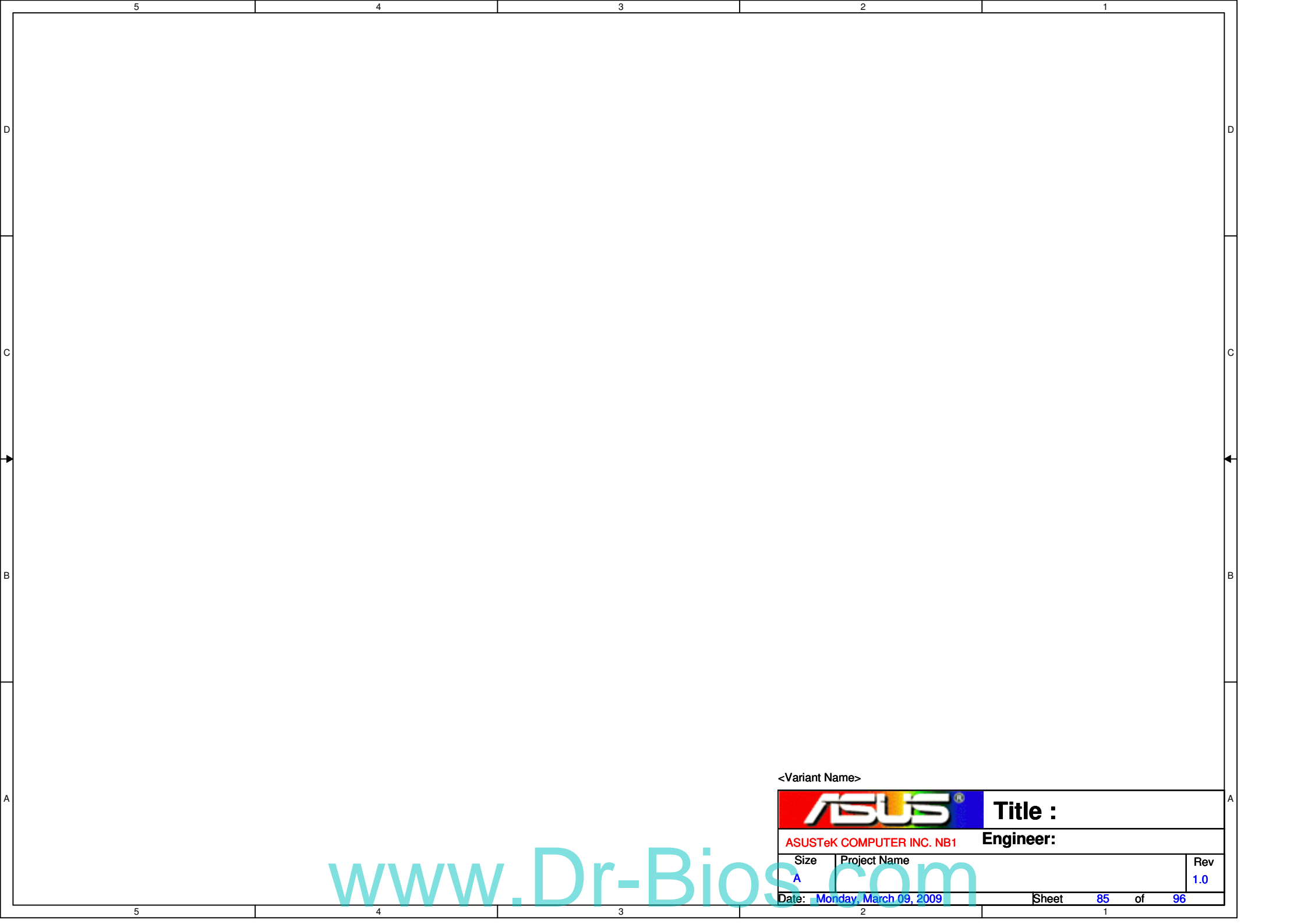

<Variant Name>

| | | |
|---|--------------|------------------------------|
|  | | Title : |
| ASUSTeK COMPUTER INC. NB1 | | Engineer: |
| Size | Project Name | Rev |
| A | | 1.0 |
| Date: <u>Monday, March 09, 2009</u> | | Sheet <u>85</u> of <u>96</u> |

www.Dr-Bios.com



| | | |
|---|--------------|--|
| <Variant Name> | | |
|  | | Title : |
| <OrgName> | | Engineer: |
| Size | Project Name | Rev |
| B | | 1.0 |
| Date: Monday, March 09, 2009 | | Sheet 86 of 96 |

5

4

3

2

1

D

D

C

C

B

B

A

A

www.Dr-Bios.com

| | | |
|---|--------------|----------------|
| <Variant Name> | | |
|  | | Title : |
| <OrgName> | | Engineer: |
| Size | Project Name | Rev |
| Custom | | 1.0 |
| Date: Monday, March 09, 2009 | | Sheet 87 of 96 |

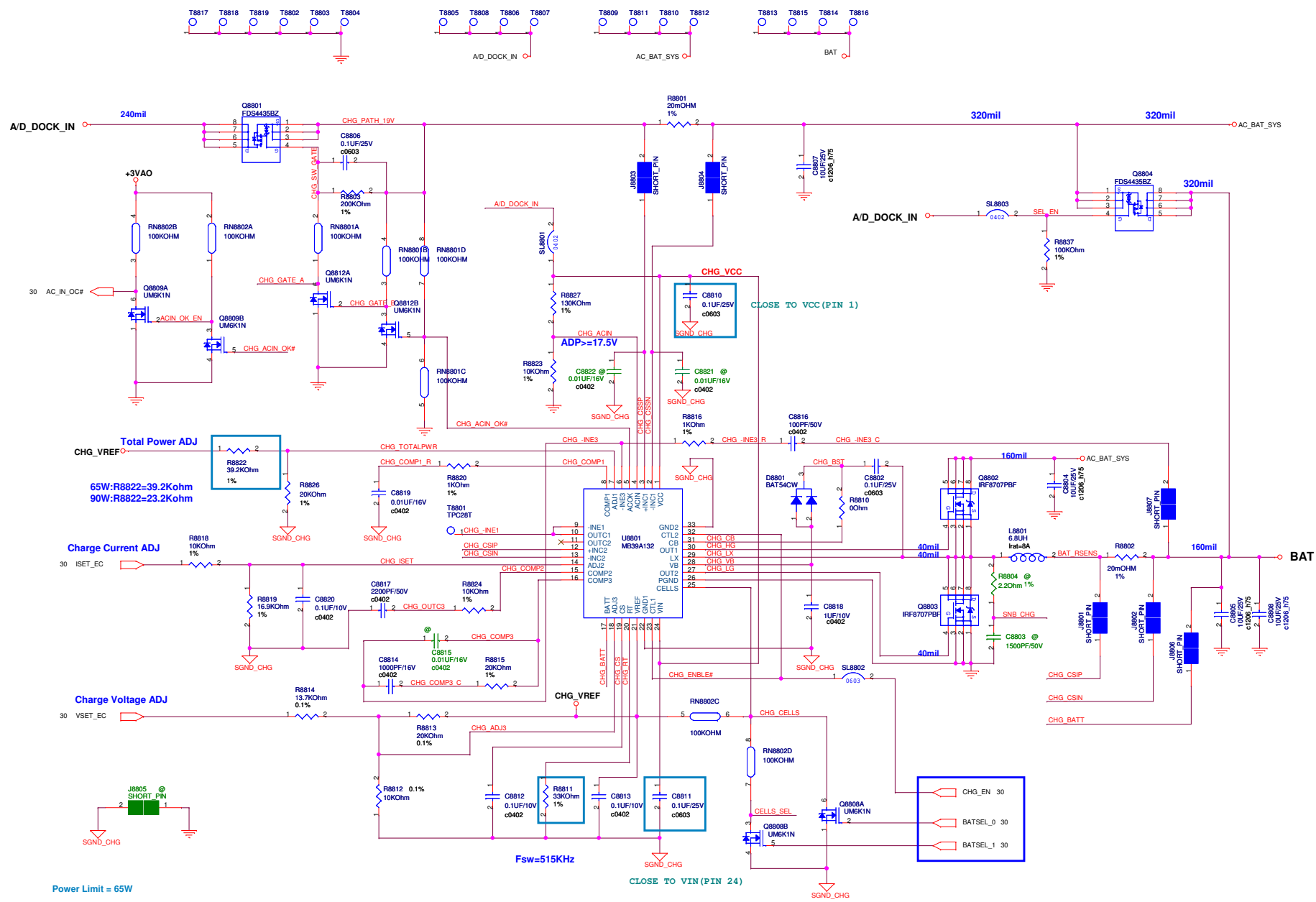

Total Power ADJ
 65W: R8822=39.2Kohm
 90W: R8822=23.2Kohm

Charge Current ADJ
 R8818 10Kohm 1%

Charge Voltage ADJ
 R8814 13.7Kohm 0.1%

Power Limit = 65W

TOTAL COUNT:56 PCS

Battery Cells

| BATSEL_1 | BATSEL_0 | CELLS |
|----------|----------|---------|
| H | H | 2 CELLS |
| L | H | 2 CELLS |
| H | L | 3 CELLS |
| L | L | 4 CELLS |

Charger IC and EC Code correlation sheet :
 Charger MAX8725 => EC CODE : 200
 Charger MAX17015 => EC CODE : 201
 Charger MB39A132 => EC CODE : 202



5

4

3

2

1

D

D

C

C

B

B

A

A

www.Dr-Bios.com

| | | |
|---|--------------|-----------|
| <Variant Name> | | |
|  | | Title : |
| <OrgName> | | Engineer: |
| Size | Project Name | Rev |
| Custom | | 1.0 |
| Date: Monday, March 09, 2009 | Sheet | 89 of 96 |

BATTERY IN DETECT

www.Dr-Bios.com

| | | |
|---|--------------|----------------------|
| <Variant Name> | | |
|  | | Title : POWER_DETECT |
| ASUSTeK COMPUTER INC. NB | | Engineer: Morris |
| Size | Project Name | Rev |
| Custom | K50II | 1.0 |
| Date: Monday, March 09, 2009 | Sheet | 90 of 96 |

SUSB#_PWR POWER

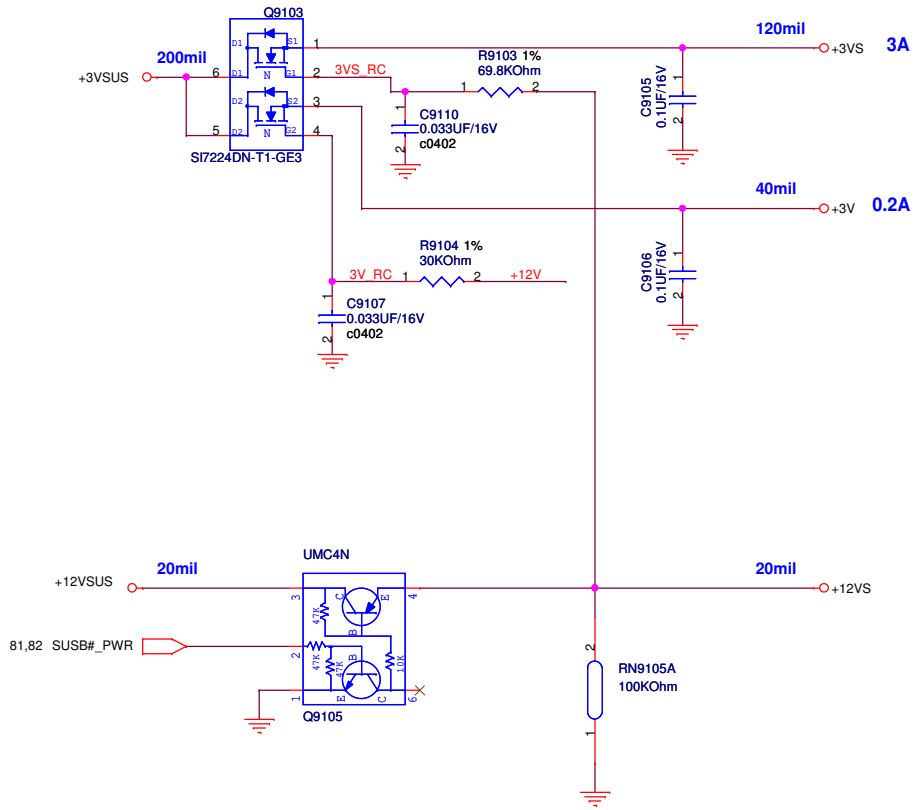

Total count: 19 pcs

SUSC#_PWR POWER

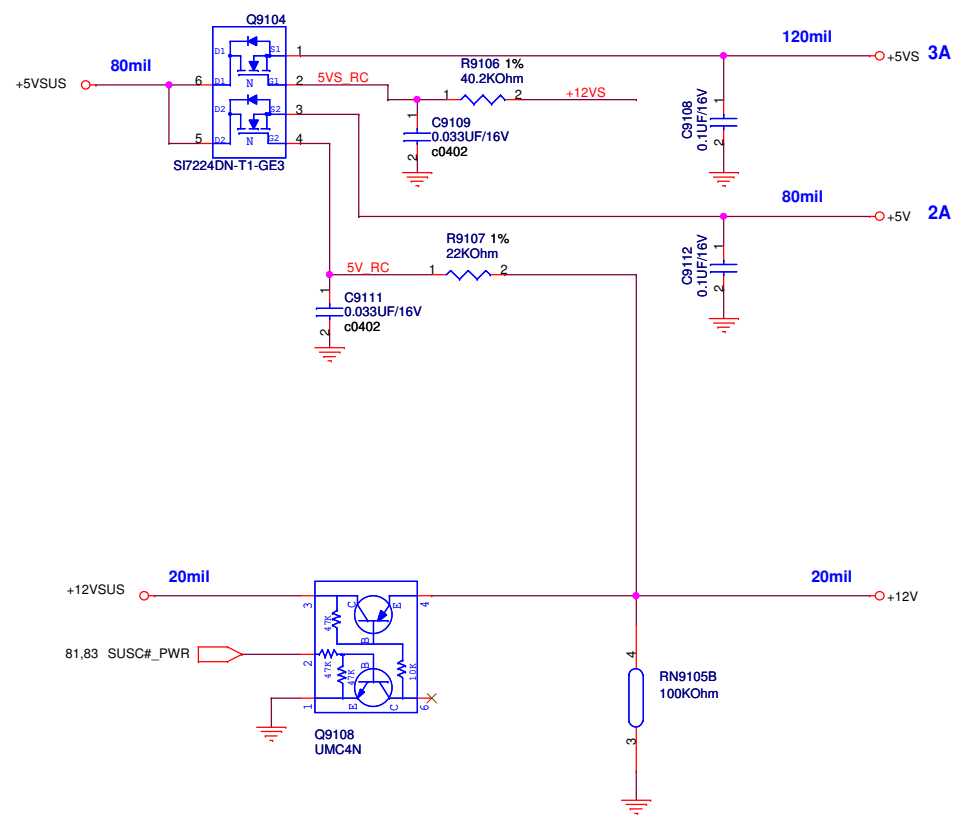

<Variant Name>

| | | | |
|------------------------------|----------------------------|---------------------------------|----------|
| ASUS | | Title :POWER_LOAD SWITCH | |
| ASUSTeK COMPUTER INC. NB | | Engineer: <i>Morris</i> | |
| Size B | Project Name K50 | Rev 1.0 | |
| Date: Monday, March 09, 2009 | | Sheet | 91 of 96 |

POWER GOOD DETECTOR

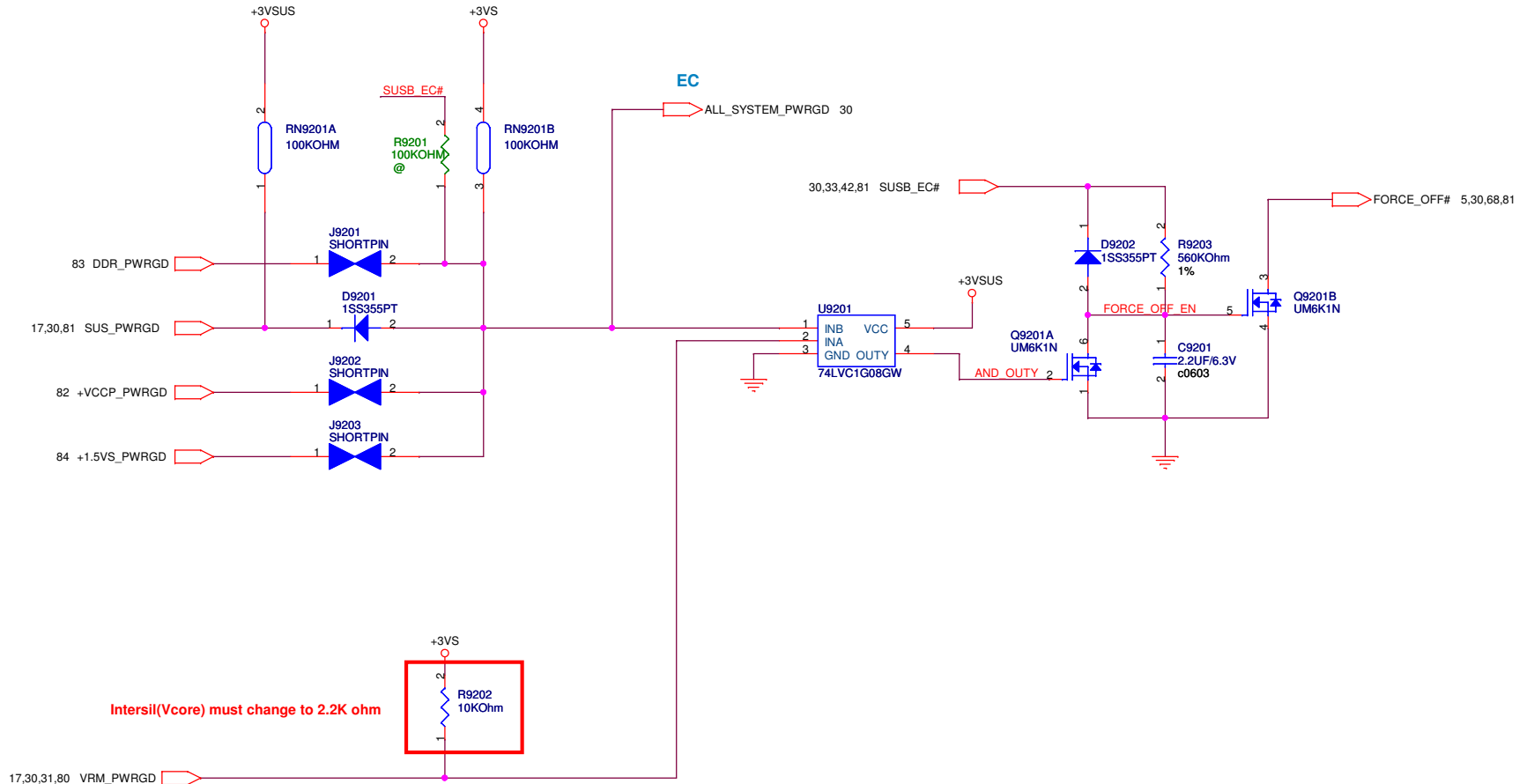

Total count: 8 pcs

| | |
|---|--------------|
| <Variant Name> | |
| ASUS Title :POWER_PROTECT | |
| ASUSTeK COMPUTER INC. NB Engineer: Morris | |
| Size | Project Name |
| B | K50 |
| Date: Monday, March 09, 2009 | Rev 1.0 |
| Sheet 92 | of 96 |

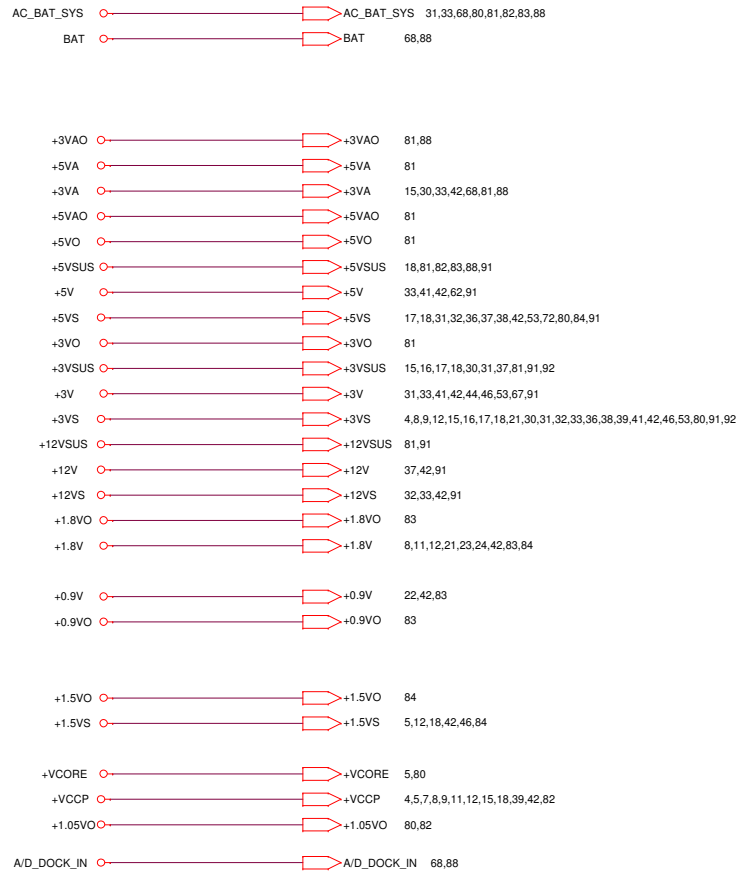

AC_BAT_SYS

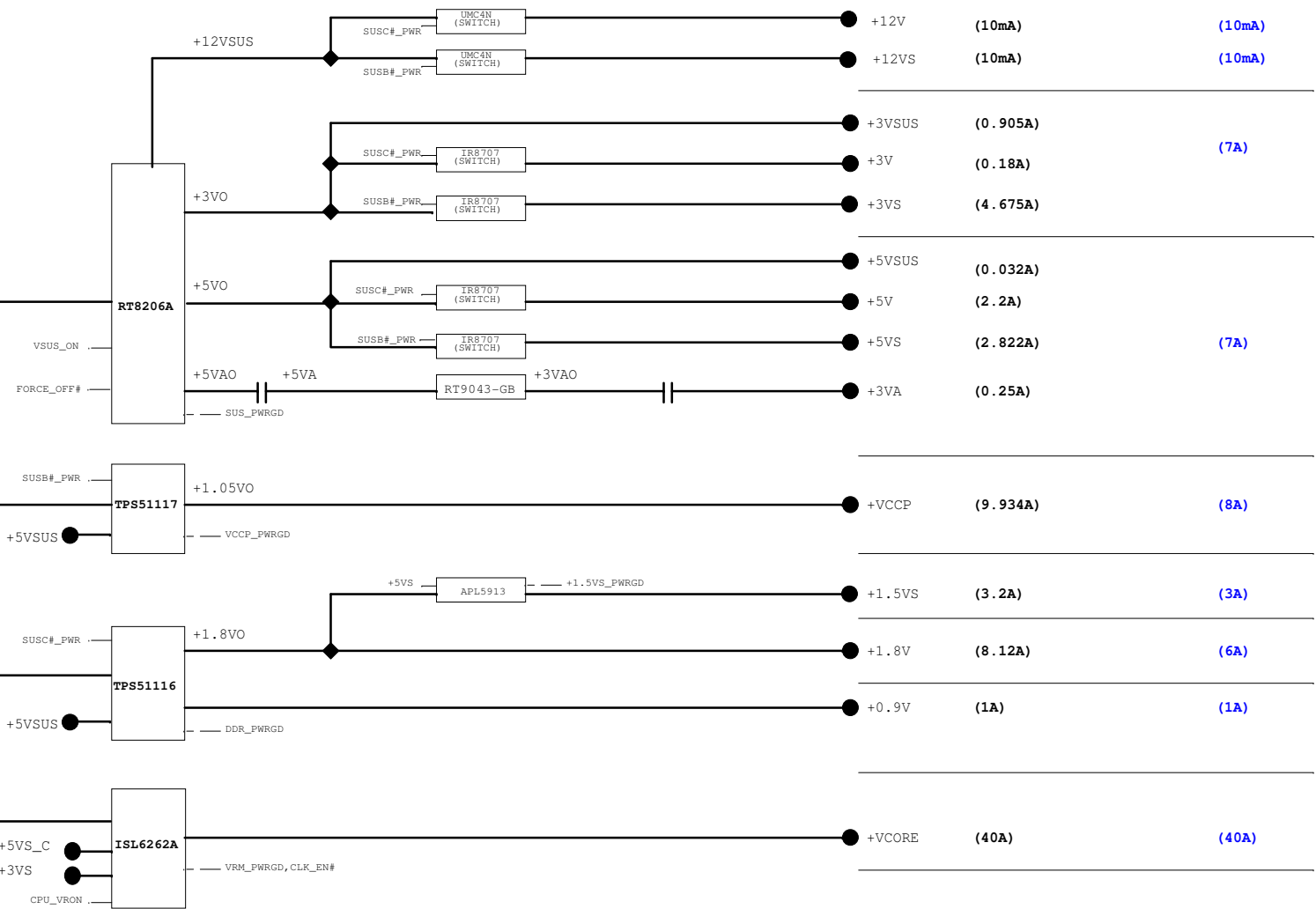

K50
Non-IAMT
Design rating

VR_VID0~VR_VID6, H_DPRSTP#,
MCH_OK, PM_DPRSLEPR, PM_PSI#,
VCCSENSE, VSSSENSE, STP_CPU#,
PWR_MON