

BLOCK DIAGRAM

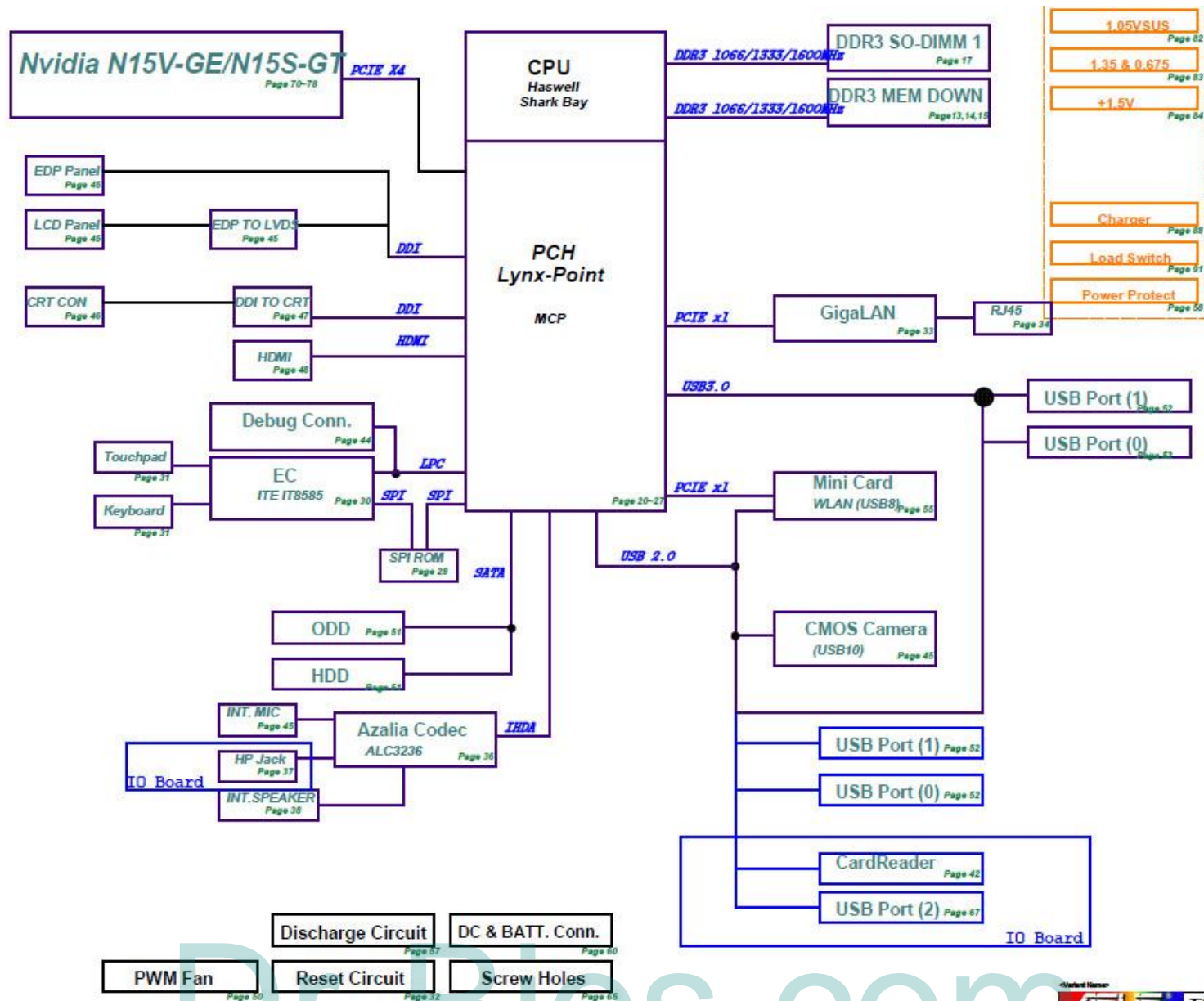

DI-BIOS.COM

POWER FLOW

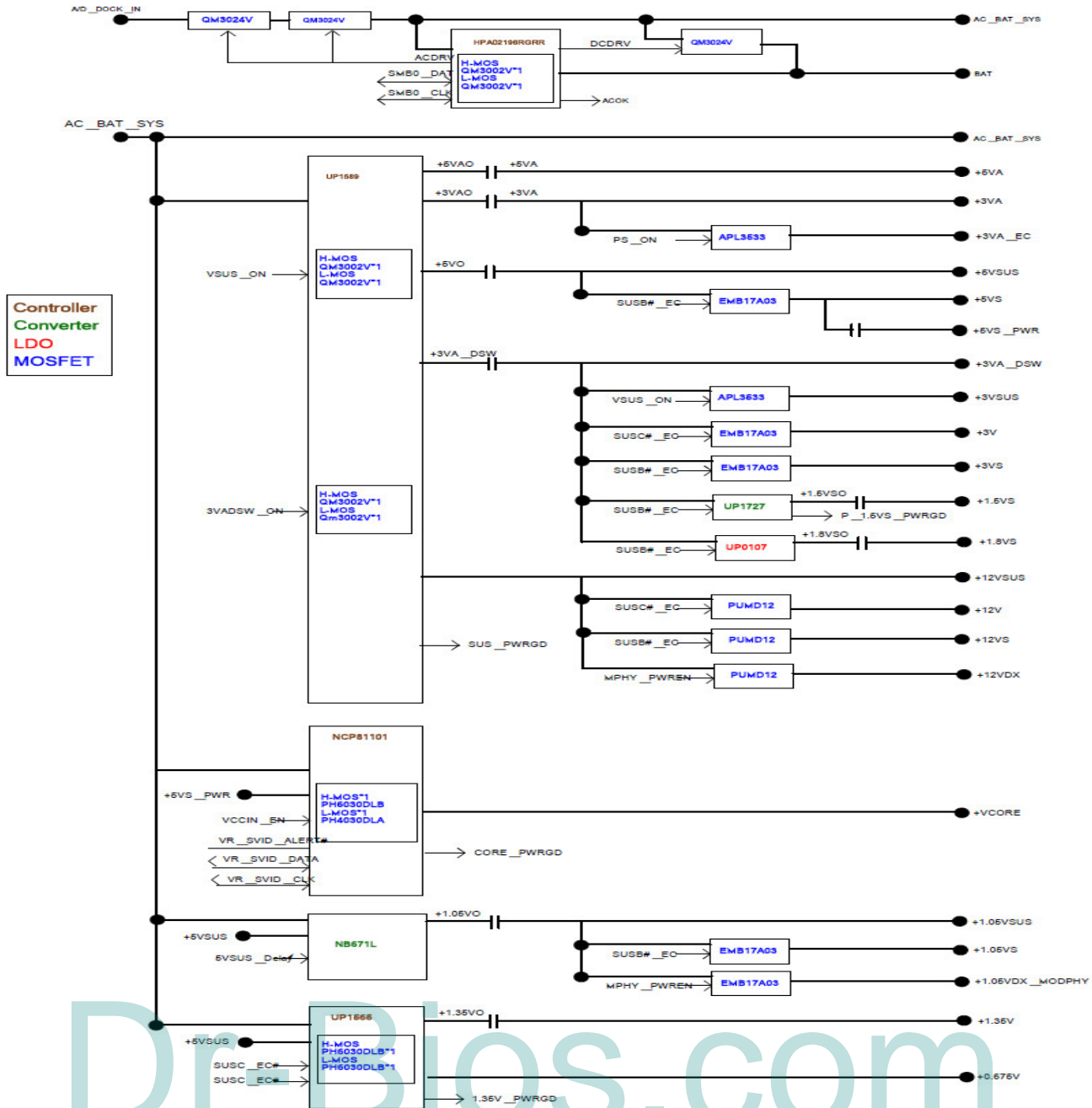

POWER ON SEQUENCE

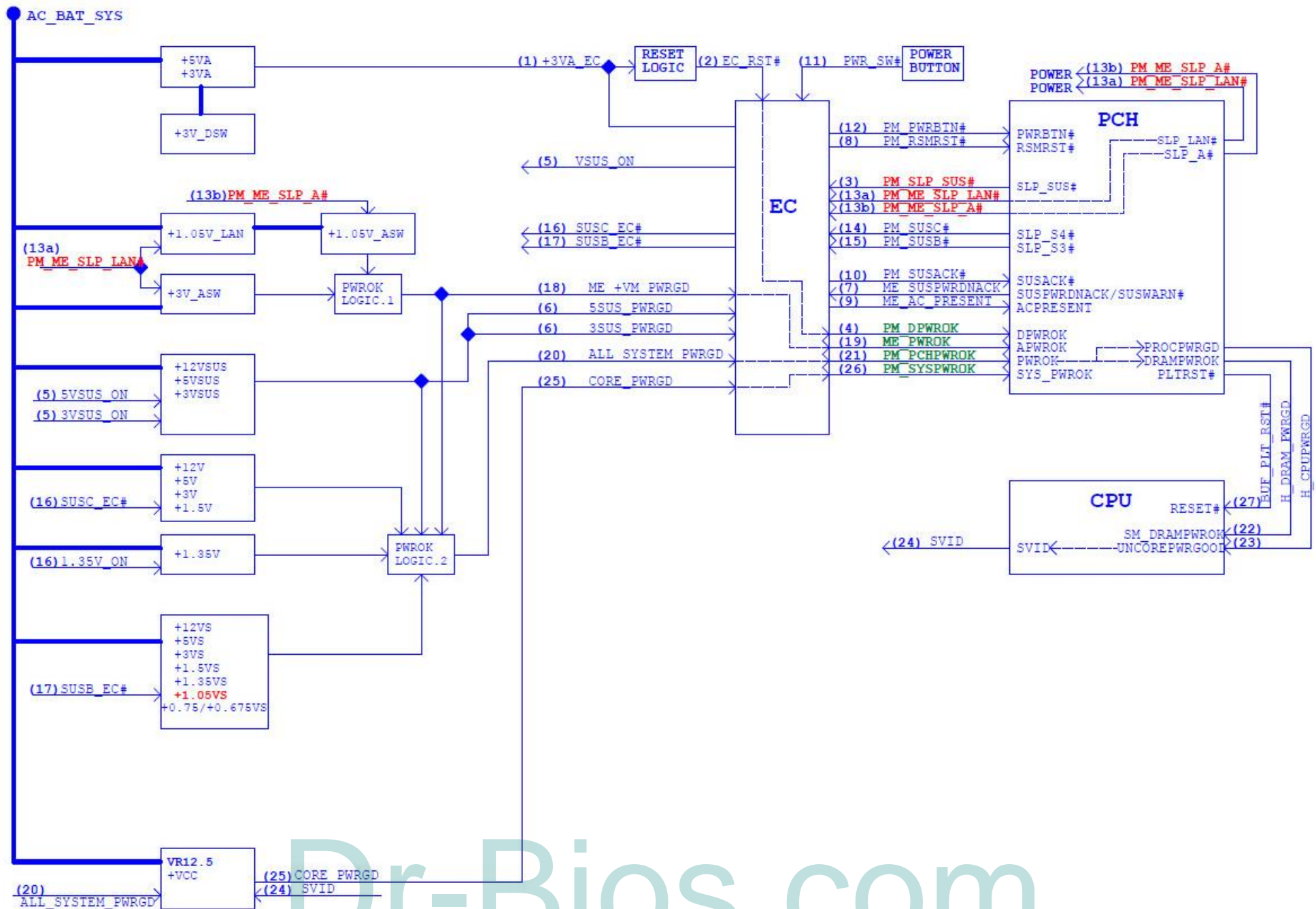

POWER ON SEQUENCE (AC Mode)

AC-IN Mode

N56JZ Power Sequence
(AC mode)

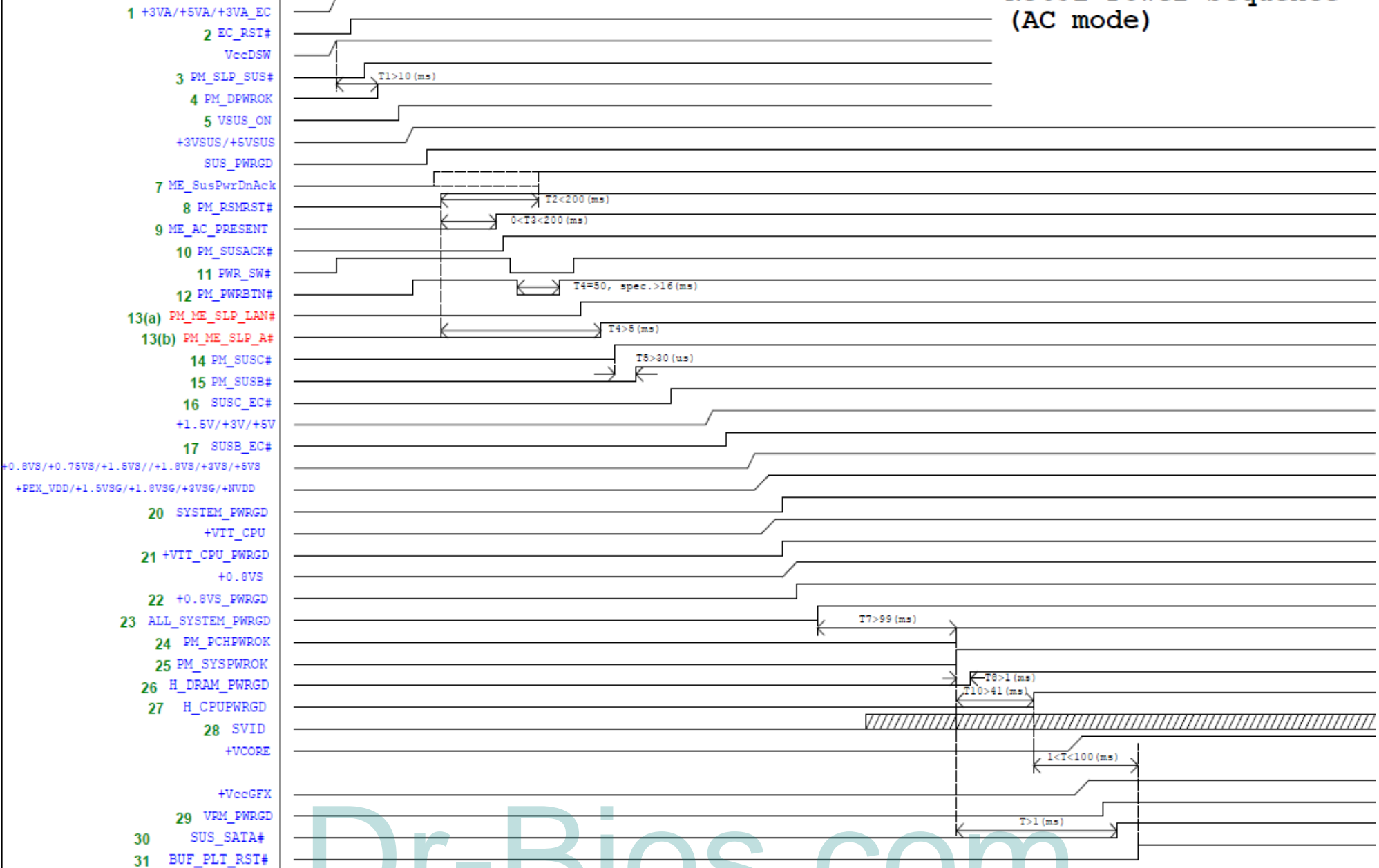

POWER ON SEQUENCE (DC Mode)

DC-IN Mode

N56JZ Power Sequence
(DC mode)

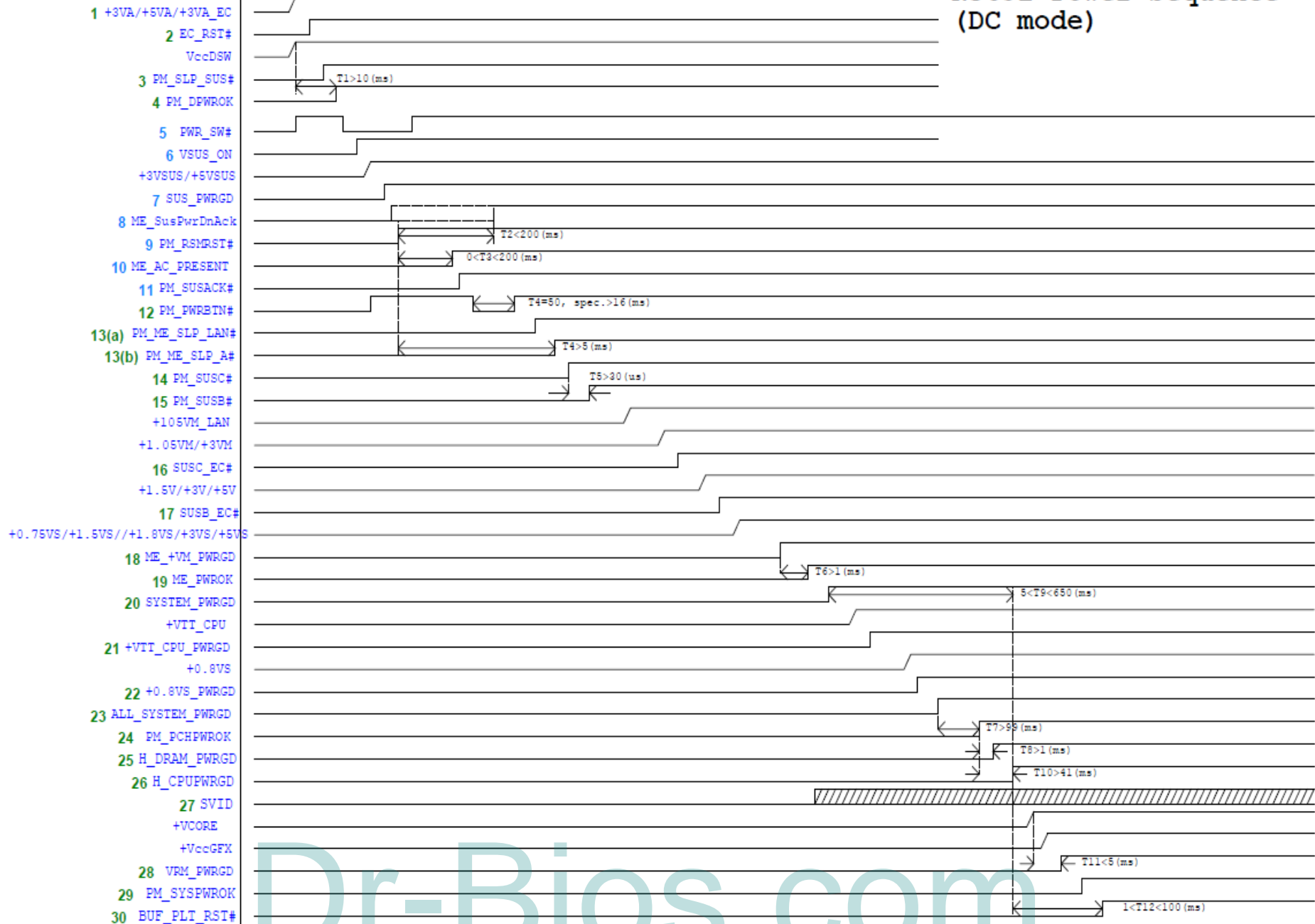

Dr-Bios.com

Signal Measure Point-Bottom

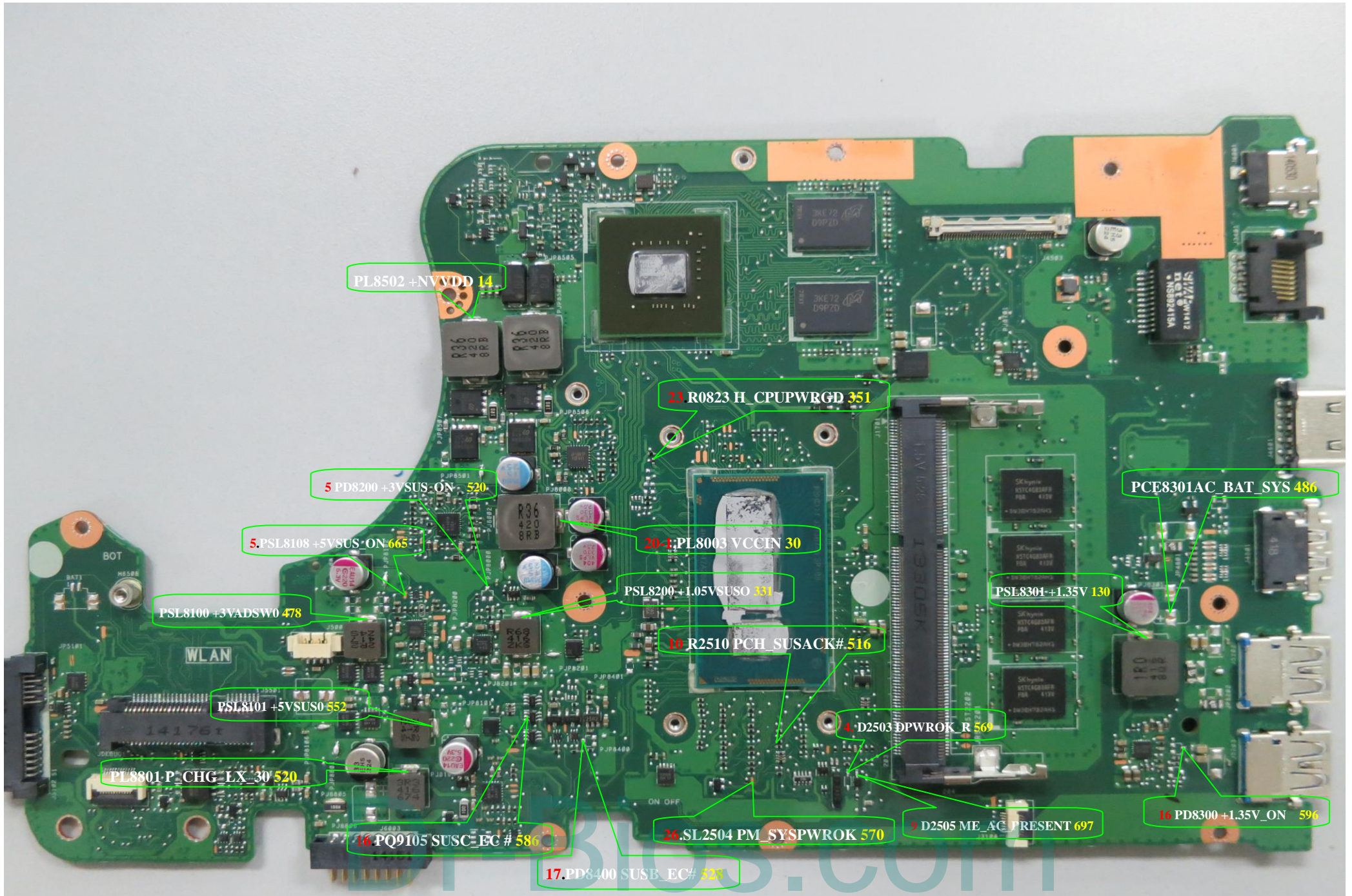

PL8502 + NVVDD 14

23 R0823 H_CPUPWRGD 351

5 PD8200 +3VSUS_ON 520

5 PSL8108 +5VSUS_ON 665

20-L:PL8003 VCCIN 30

PCE8301AC BAT_SYS 486

PSL8100 +3VADSW0 478

PSL8200 +1.05VSUS0 331

PSL8301 +1.35V 130

10 R2510 PCH_SUSACK# 516

4-D2503 DPWROK R 569

PSL8101 +5VSUS0 552

26 SL2504 PM_SYSPWROK 570

9 D2505 ME_AC_PRESENT 697

PL8801 P_CHG_LX_30 520

16 PQ9105 SUSC_EC # 586

17 PD8400 SUSB_EC# 525

16 PD8300 +1.35V_ON 596

Signal Measure Point-Top

