

BLOCK DIAGRAM

X540LJ SCHEMATIC Revision R1.0

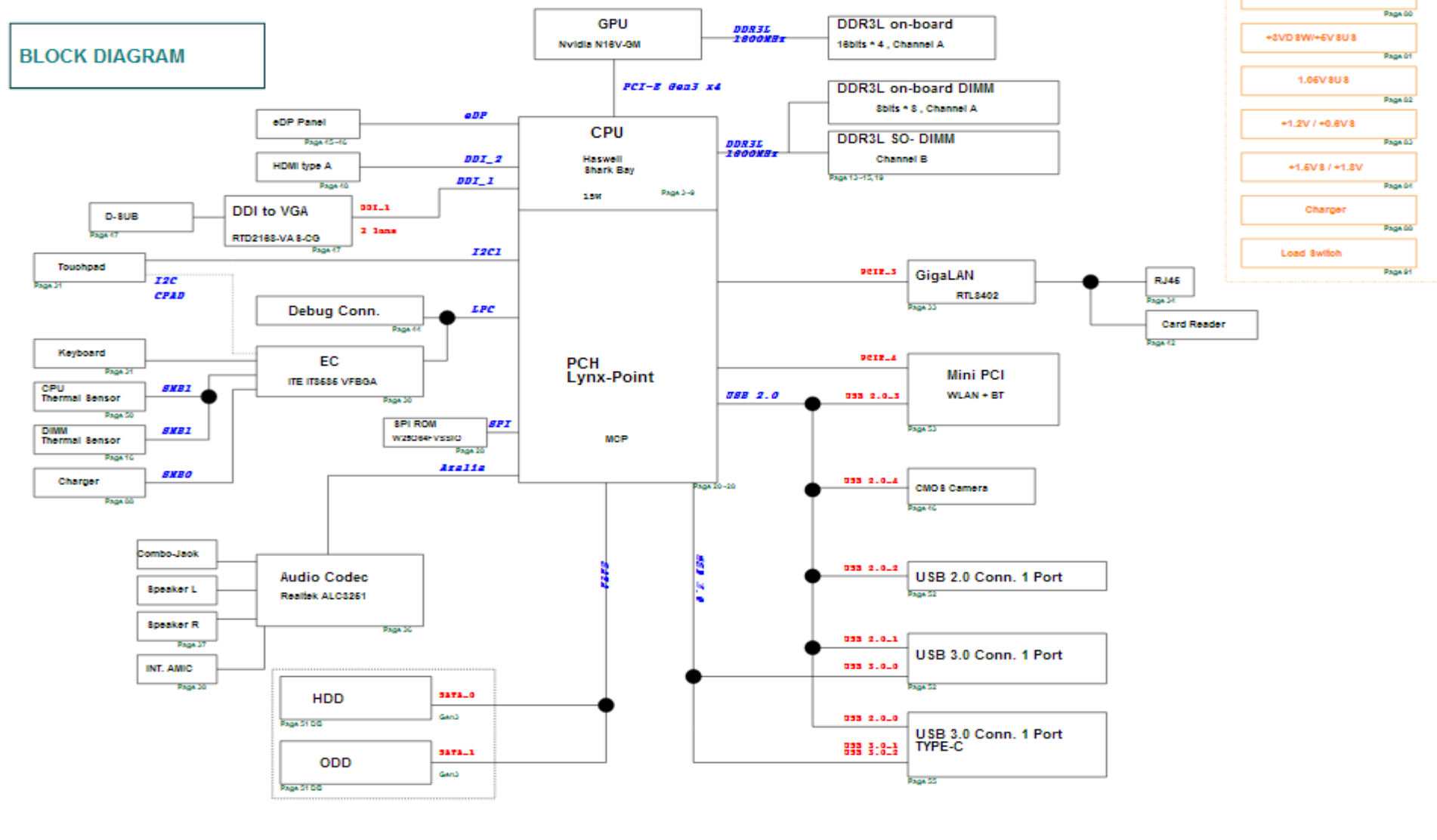

POWER FLOW

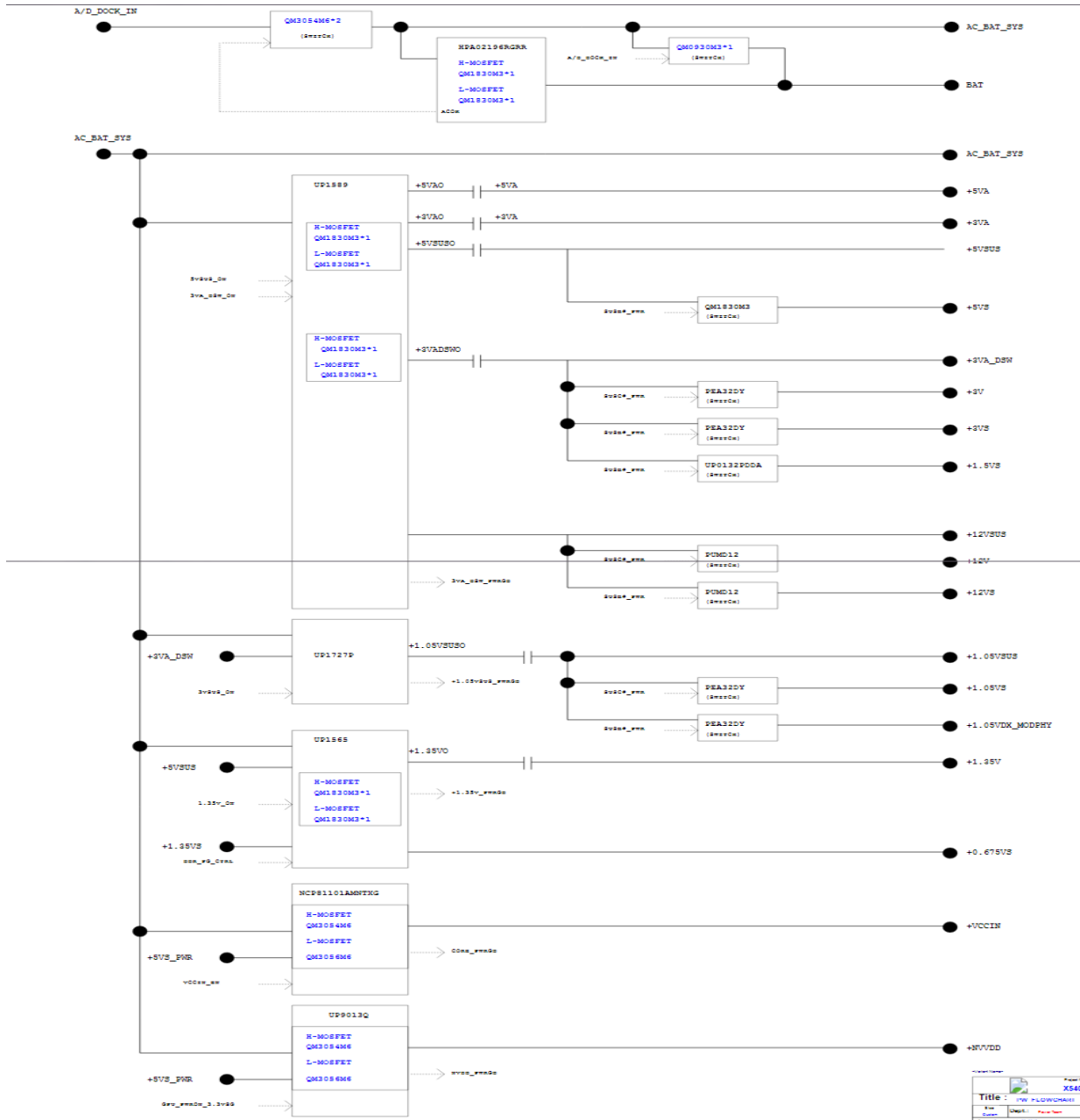

POWER ON SEQUENCE

UX303JA Power On Sequence Diagram Rev.0.1

AC-IN Mode

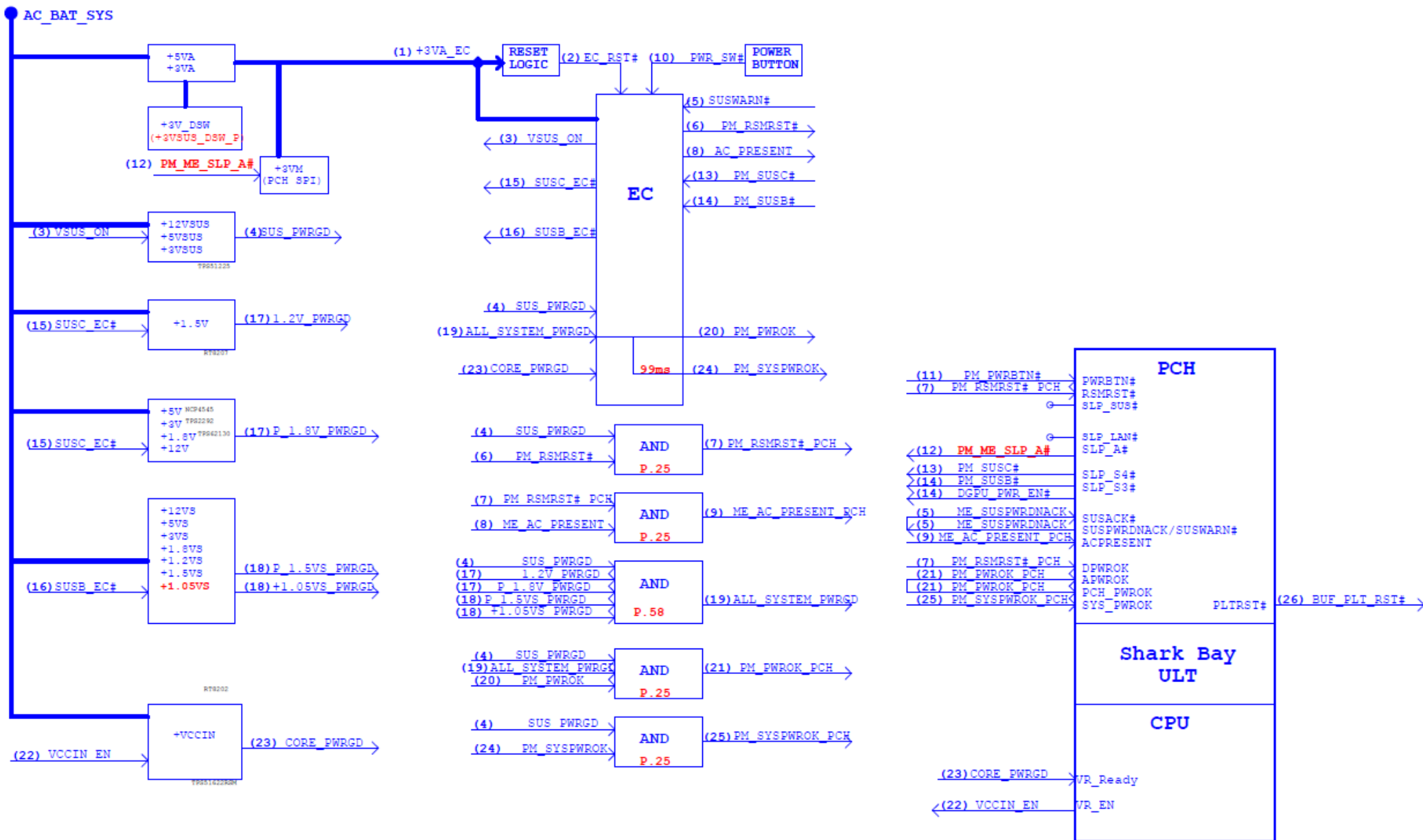

AC POWER ON SEQUENCE

UX303JA Power-On Sequence Timing Diagram Rev.0.1

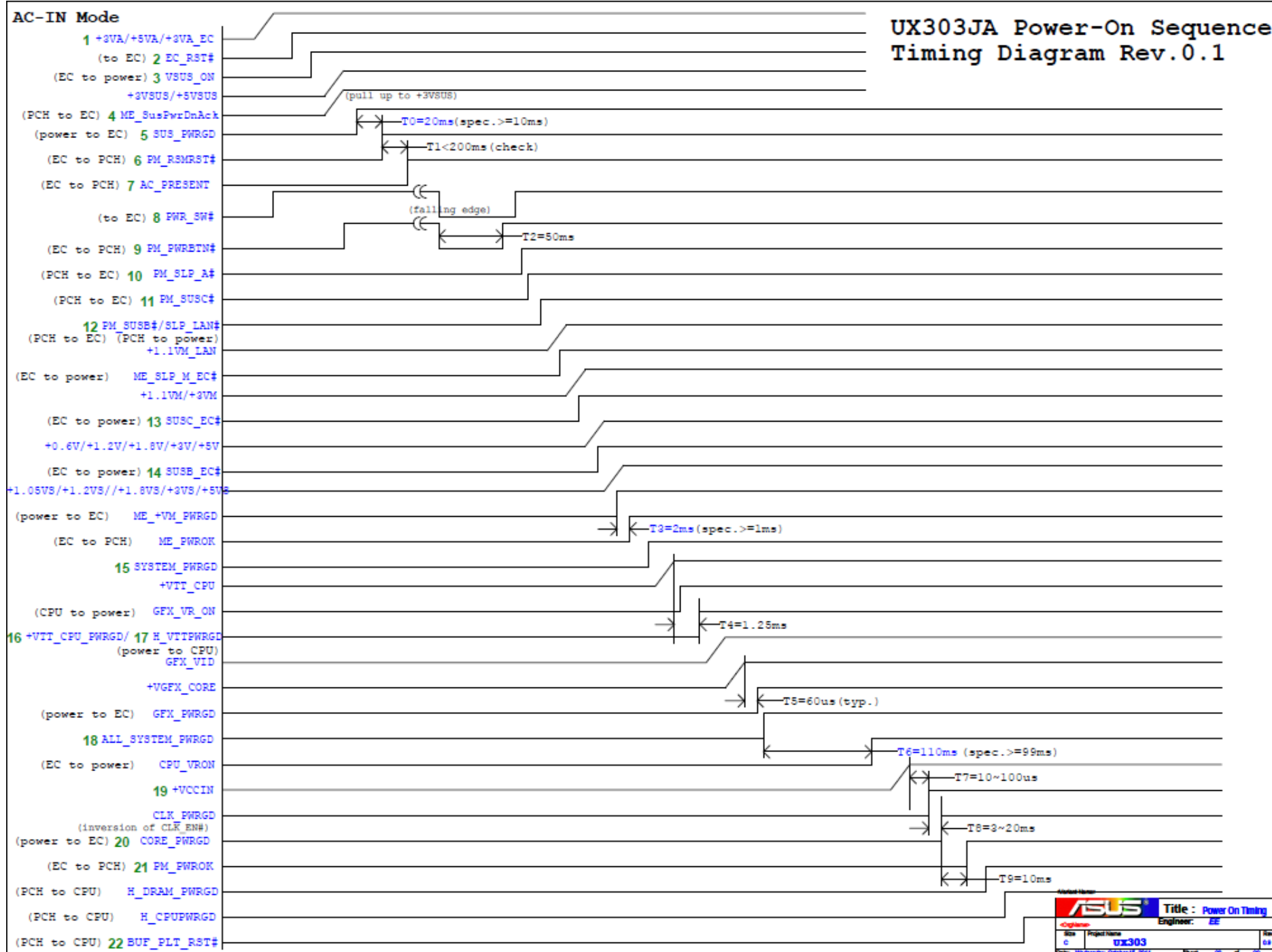

Signal Measure Point-Bottom

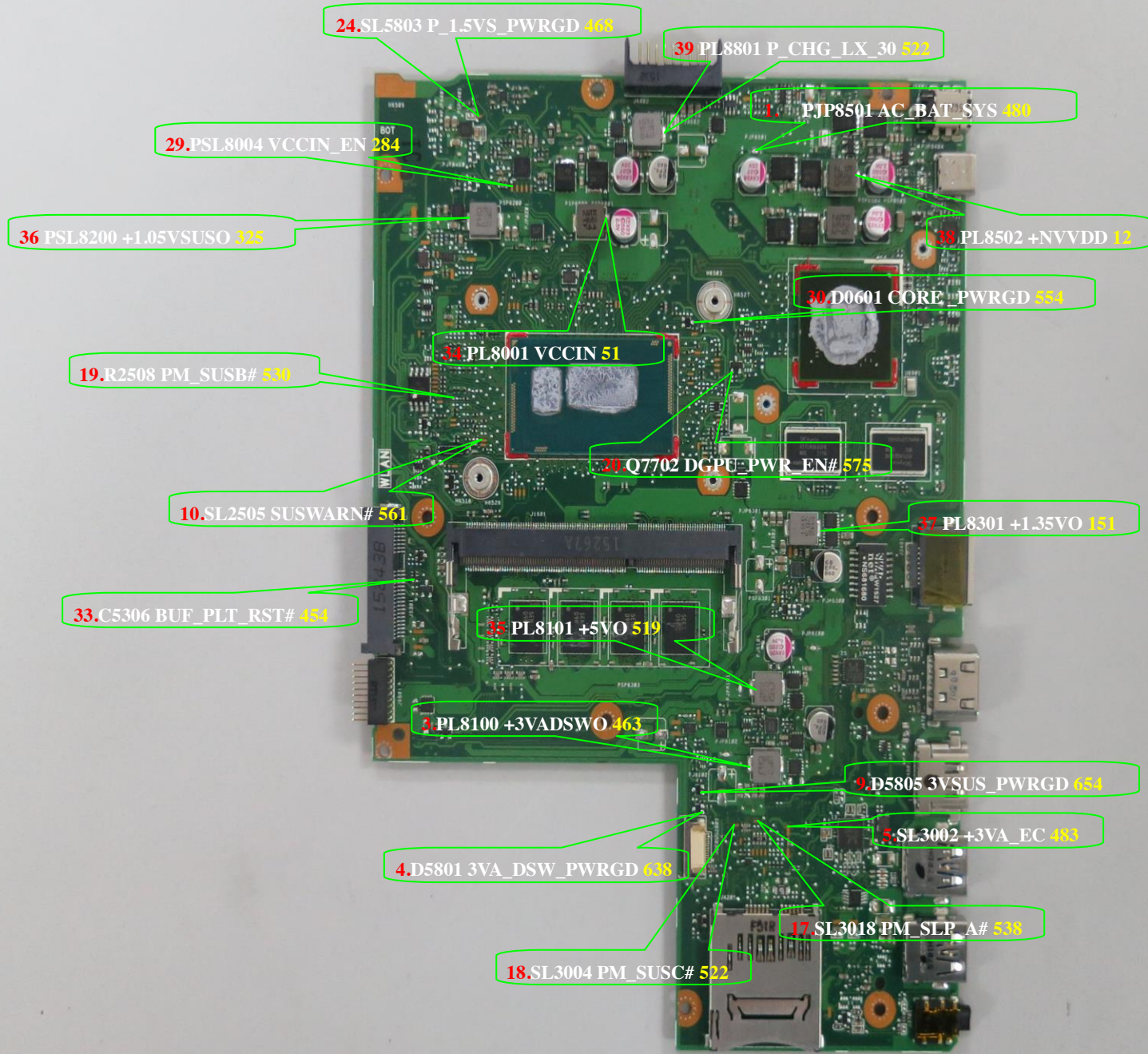

Signal Measure Point-Top

