

F5R BLOCK DIAGRAM

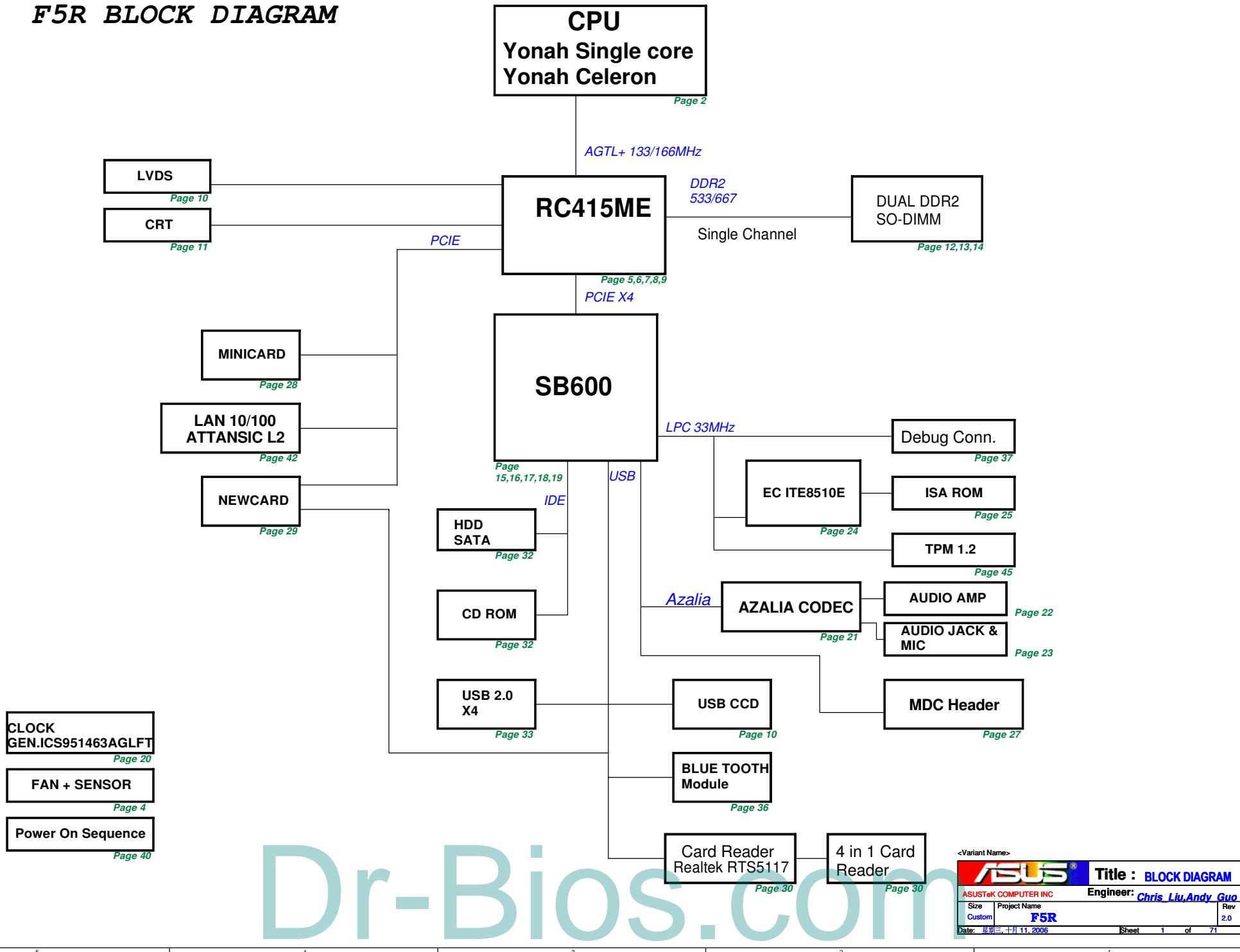

Dr-Bios.com

ASUS		Title : BLOCK DIAGRAM	
ASUSTeK COMPUTER INC		Engineer: Chris Liu, Andy Guo	
Size	Project Name	Rev	
Custom	F5R	2.0	
Date: 2006年10月11日	Sheet	1	of 71

R1.1

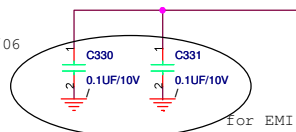
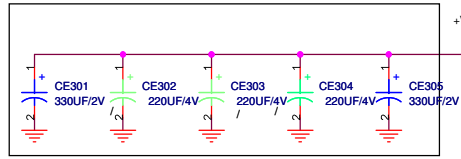

CPU +VCCORE
Mid-Frequency
Capacitors

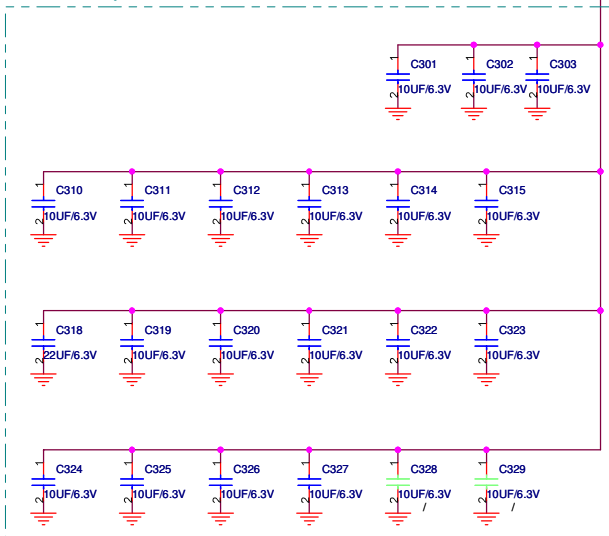

+VCCORE Low-Freq Capacitor

- Intel: 330UF *6
- ATI: 330UF *6
- R1F: 330UF *4
- A7J: 330UF *5
- F5X: 330UF *5

+VCCORE Mid-Frequency Capacitor

- Intel: 22UF *32
- ATI: 10UF *26
- R1F: 22UF *16
- A7J: 22UF*29 use 19
- A6RF: 22UF*21 use 21
- F5X: 10UF *21 use 19

+VCCP Decoupling Capacitor

- Intel: 270UF *1, 0.1UF *6
- R1F: 220UF *1, 0.1UF *4
- A7J: 220UF *1, 0.1UF *6
- A6RF: 220UF *1, 0.1UF *6
- F5X: 220UF *1, 0.1UF *6

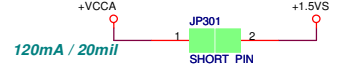
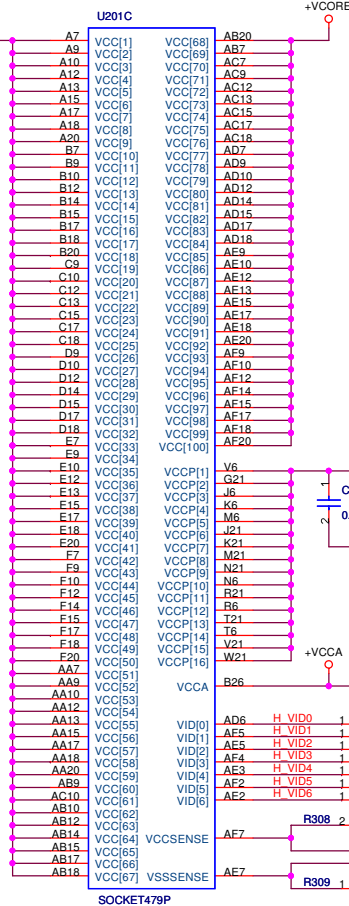

+VCCA
Decoupling
Capacitors

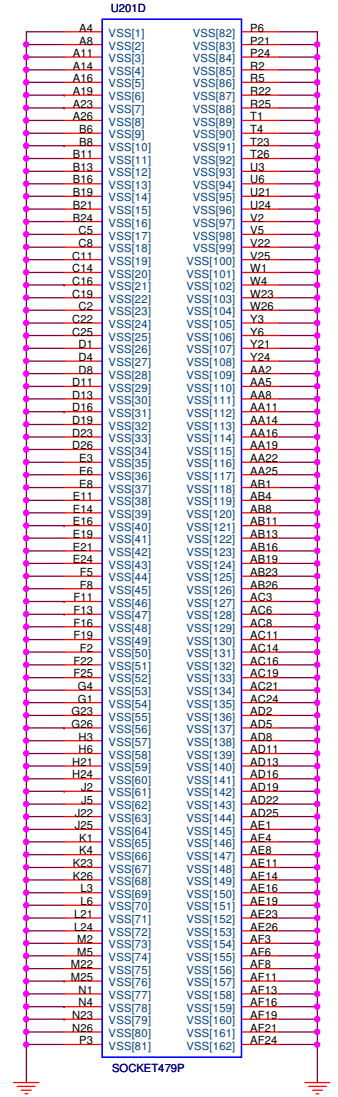
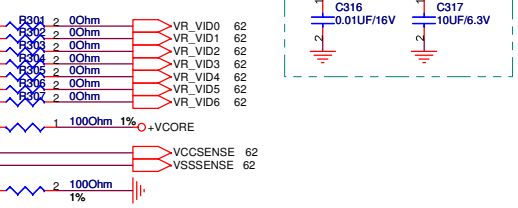

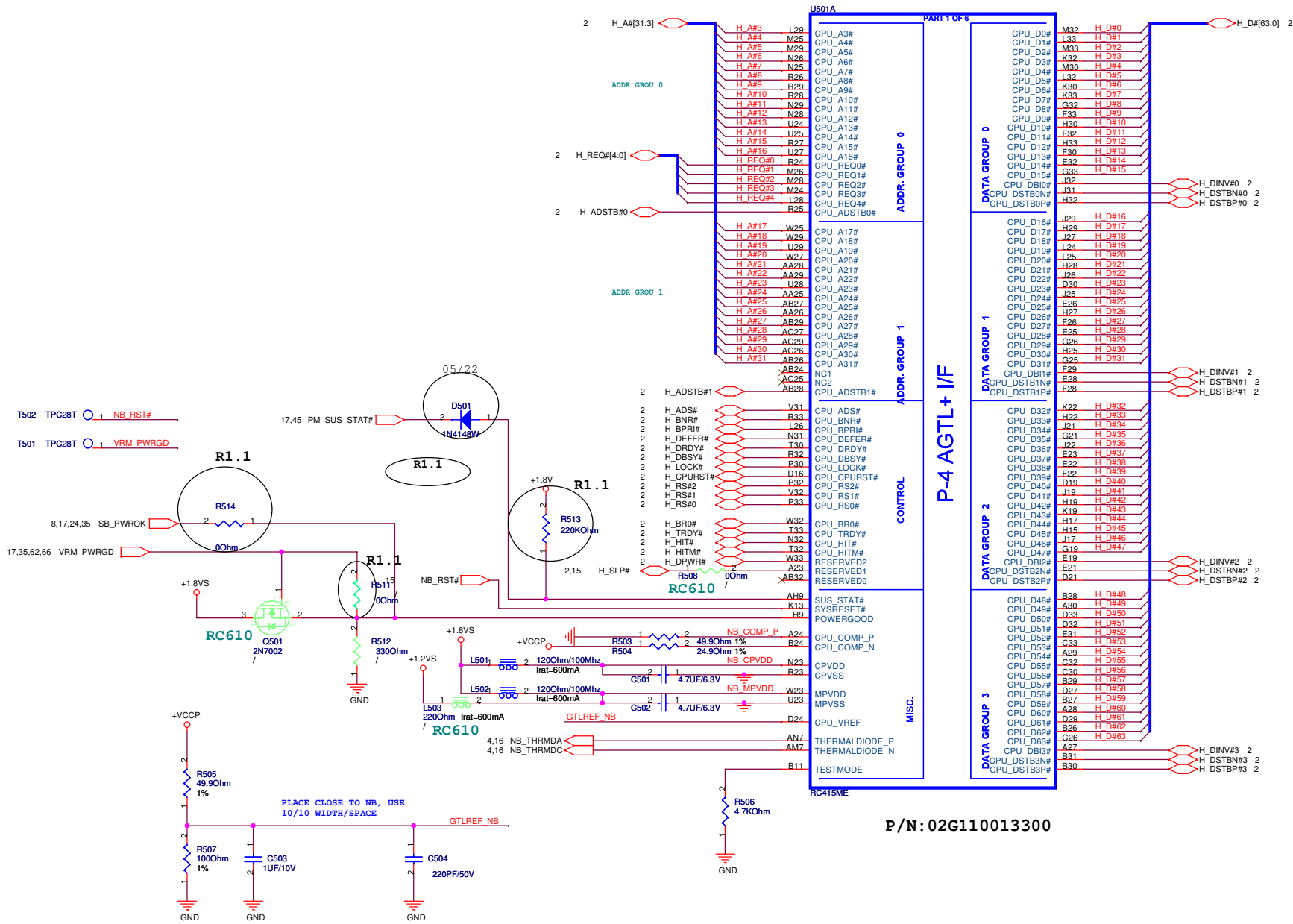

P/N: 02G110013300

Dr-Bios.com

<Variant Name>

ASUS Title : RC415M(HOST)
 ASUSTeK COMPUTER INC Engineer: Chris_lju,Andy_Guo

Size	Project Name	Rev
Custom	F5R	2.0

Date: 2006年10月11日 Sheet 5 of 71

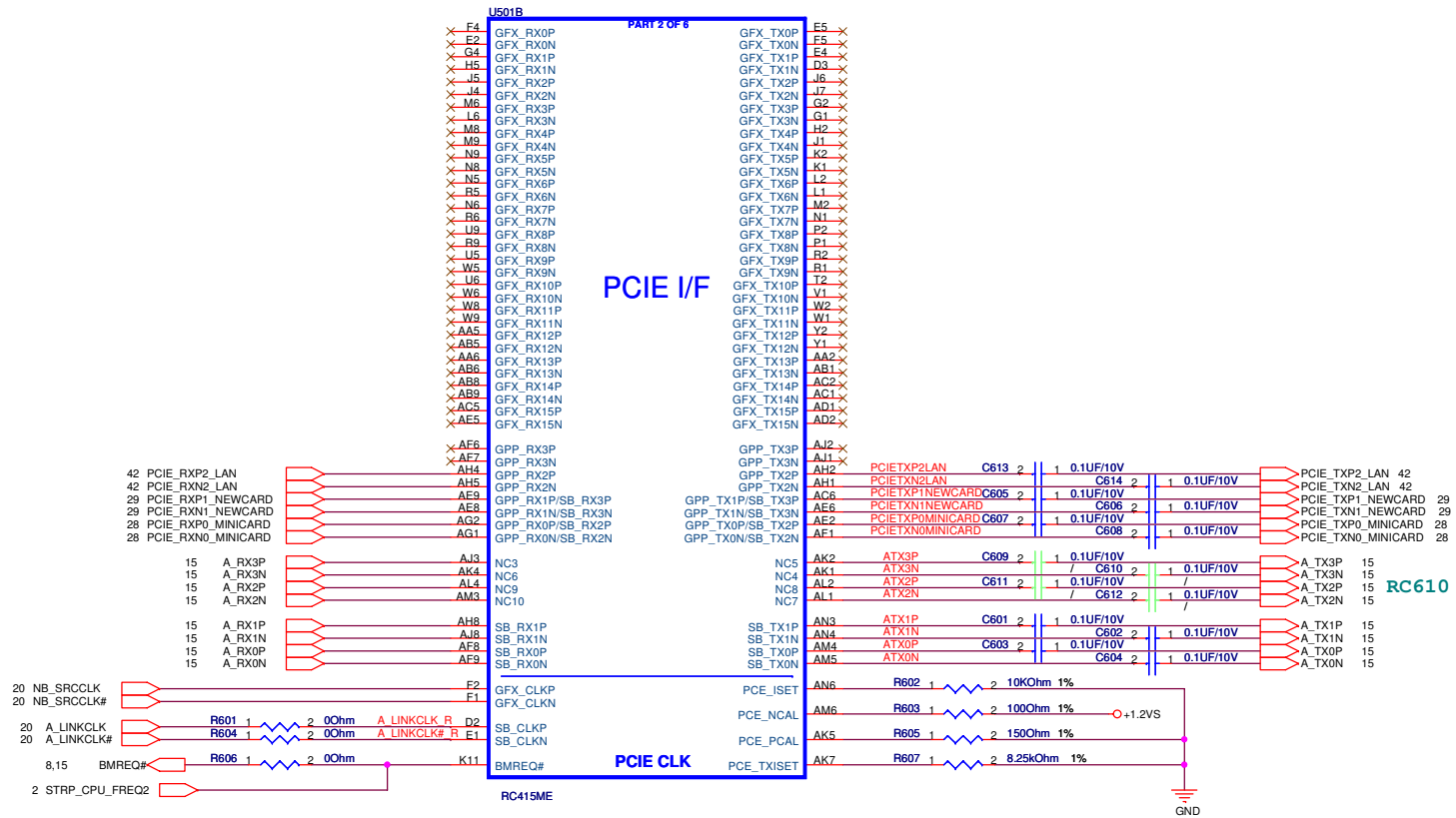

Dr-Bios.com

<Variant Name>

ASUS Title : RC415M(2)
 ASUSTeK COMPUTER INC Engineer: Chris_lju,Andy_Guo

Size	Project Name	Rev
Custom	F5R	2.0

Date: 星期三, 十月 11, 2006 Sheet 6 of 71

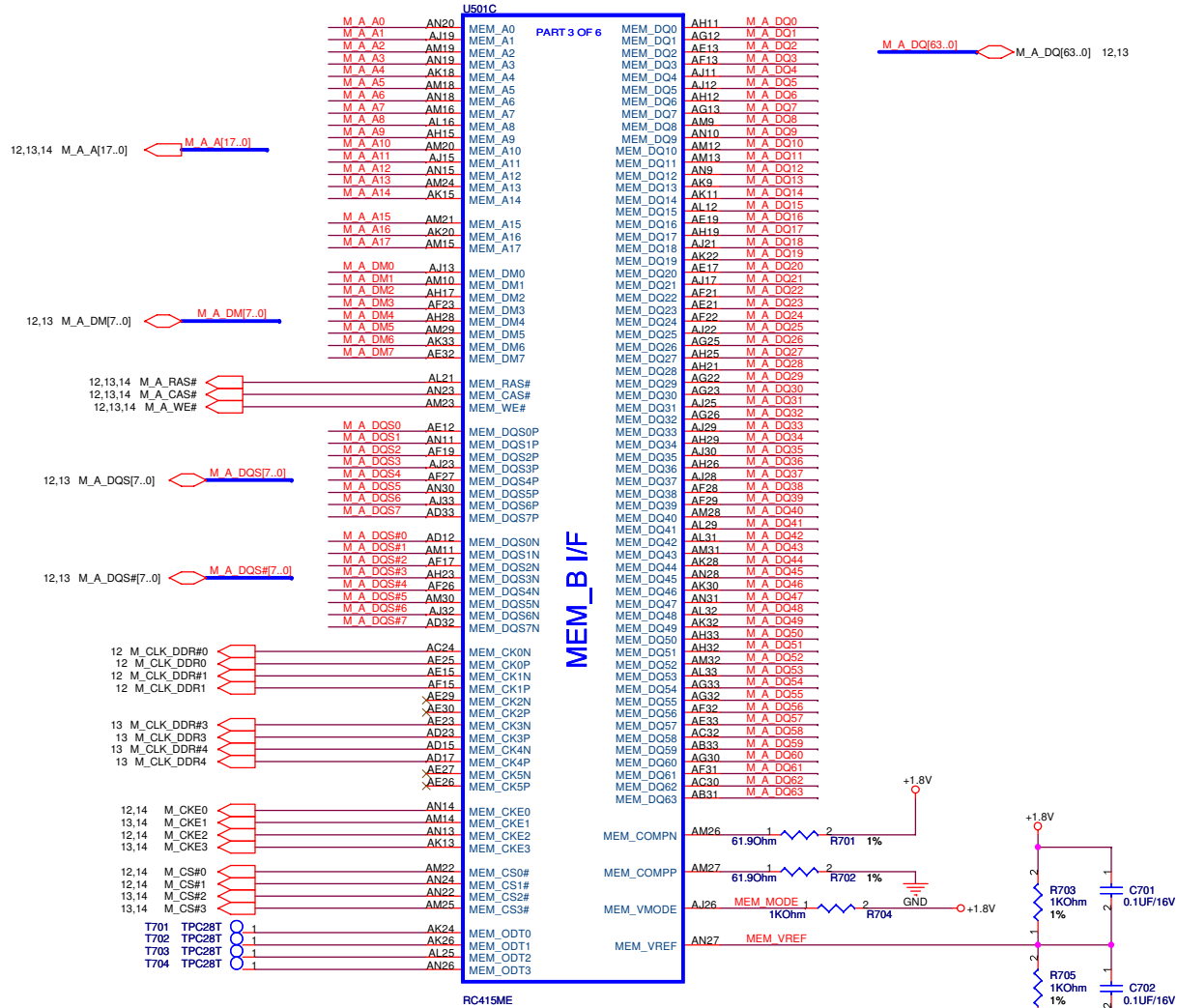

Dr-Bios.com

<Variant Name>

ASUS Title : RC415M(3)

ASUSTeK COMPUTER INC Engineer: Chris Liu, Andy Guo

Size	Project Name	Rev
Custom	F5R	2.0

Date: 星期三, 十月 11, 2006 Sheet 7 of 71

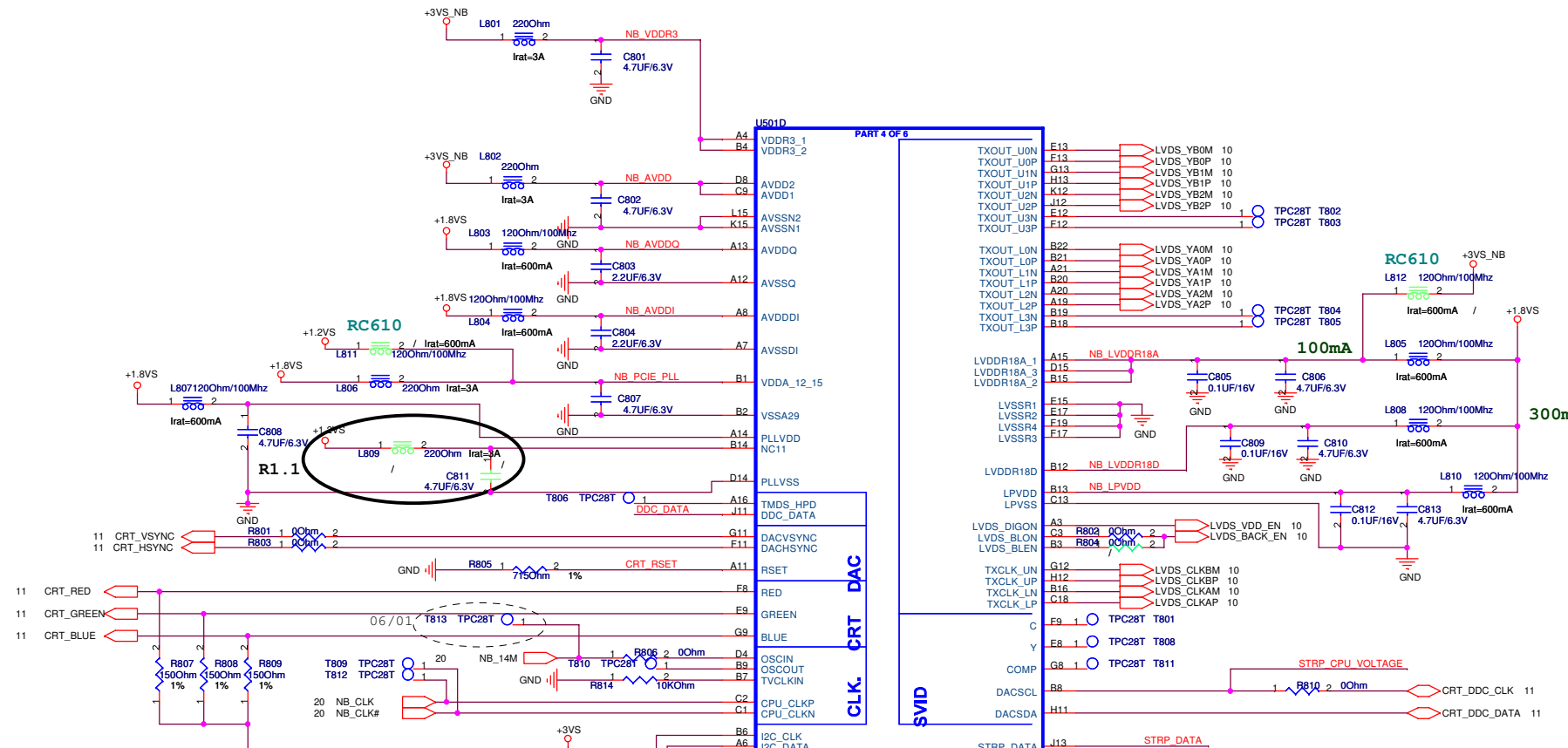

STRAPS

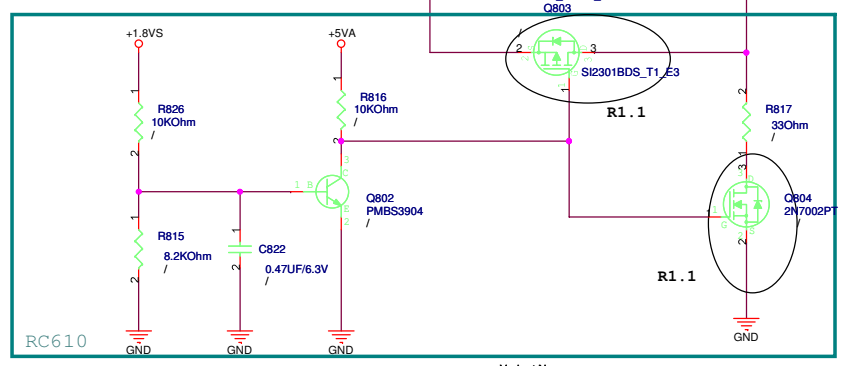
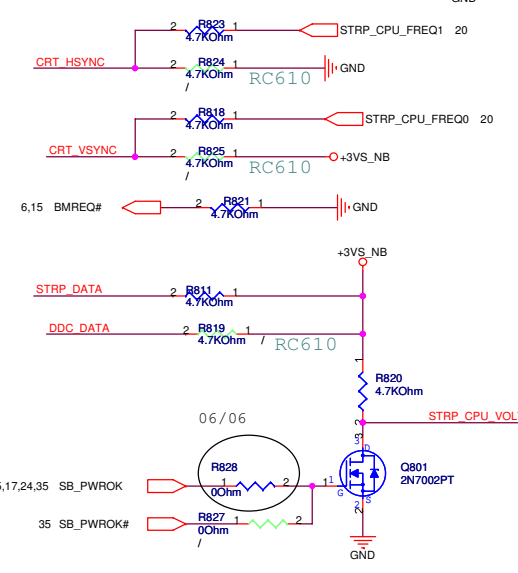

Dr-Bios.com

ASUS
Title : RC415M(4)
 ASUSTeK COMPUTER INC
 Engineer: *Chris_Liu,Andy_guo*
 Size Project Name
 Custom **F5R**
 Date: 2006年10月11日
 Sheet 8 of 71
 Rev 2.0

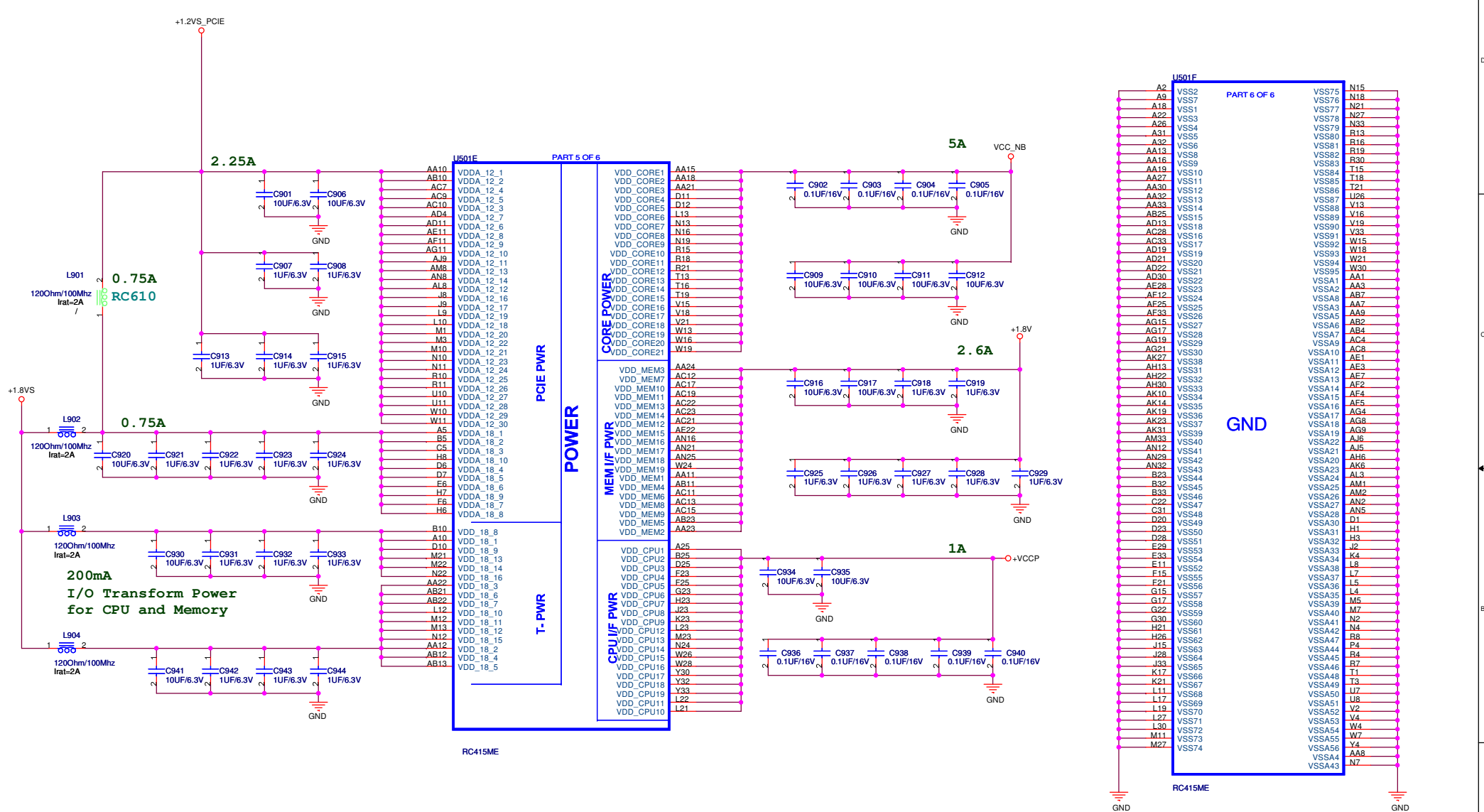

U501F PART 6 OF 6

A2	VSS2	N15
A9	VSS7	N18
A18	VSS1	N21
A22	VSS3	N27
A26	VSS4	N33
A31	VSS5	R13
A32	VSS6	R16
AA13	VSS8	R19
AA16	VSS9	R30
AA19	VSS10	T15
AA27	VSS11	T18
AA30	VSS12	VSS86
AA32	VSS13	VSS87
AA33	VSS14	VSS88
AB05	VSS15	VSS89
AD13	VSS16	VSS90
AC28	VSS17	VSS91
AC33	VSS18	VSS92
AD19	VSS19	VSS93
AD21	VSS20	VSS94
AD22	VSS21	VSS95
AD30	VSS22	VSSA1
AE28	VSS23	VSSA2
AF12	VSS24	VSSA3
AE25	VSS25	VSSA4
AF33	VSS26	VSSA5
AG15	VSS27	VSSA6
AG17	VSS28	VSSA7
AG19	VSS29	VSSA8
AG21	VSS30	VSSA9
AK27	VSS31	VSSA10
AH13	VSS32	VSSA11
AH22	VSS33	VSSA12
AH30	VSS34	VSSA13
AK14	VSS35	VSSA14
AK19	VSS36	VSSA15
AK23	VSS37	VSSA16
AK31	VSS38	VSSA17
AM33	VSS39	VSSA18
AN12	VSS40	VSSA19
AN29	VSS41	VSSA20
AN32	VSS42	VSSA21
B23	VSS43	VSSA22
B32	VSS44	VSSA23
B33	VSS45	VSSA24
C22	VSS46	VSSA25
C31	VSS47	VSSA26
D20	VSS48	VSSA27
D23	VSS49	VSSA28
D28	VSS50	VSSA29
E29	VSS51	VSSA30
E33	VSS52	VSSA31
F11	VSS53	VSSA32
F15	VSS54	VSSA33
F21	VSS55	VSSA34
G15	VSS56	VSSA35
G17	VSS57	VSSA36
G22	VSS58	VSSA37
G30	VSS59	VSSA38
H21	VSS60	VSSA39
H26	VSS61	VSSA40
J15	VSS62	VSSA41
J28	VSS63	VSSA42
J33	VSS64	VSSA43
K17	VSS65	VSSA44
K21	VSS66	VSSA45
L11	VSS67	VSSA46
L17	VSS68	VSSA47
L19	VSS69	VSSA48
L27	VSS70	VSSA49
L30	VSS71	VSSA50
M11	VSS72	VSSA51
M17	VSS73	VSSA52
M27	VSS74	VSSA53
		VSSA54
		VSSA55
		VSSA56
		VSSA57
		VSSA58
		VSSA59
		VSSA60
		VSSA61
		VSSA62
		VSSA63
		VSSA64
		VSSA65
		VSSA66
		VSSA67
		VSSA68
		VSSA69
		VSSA70
		VSSA71
		VSSA72
		VSSA73
		VSSA74
		VSSA75
		VSSA76
		VSSA77
		VSSA78
		VSSA79
		VSSA80
		VSSA81
		VSSA82
		VSSA83
		VSSA84
		VSSA85
		VSSA86
		VSSA87
		VSSA88
		VSSA89
		VSSA90
		VSSA91
		VSSA92
		VSSA93
		VSSA94
		VSSA95
		VSSA96
		VSSA97
		VSSA98
		VSSA99
		VSSA100

Dr-Bios.com

LCD Backlight Control

LCD Power

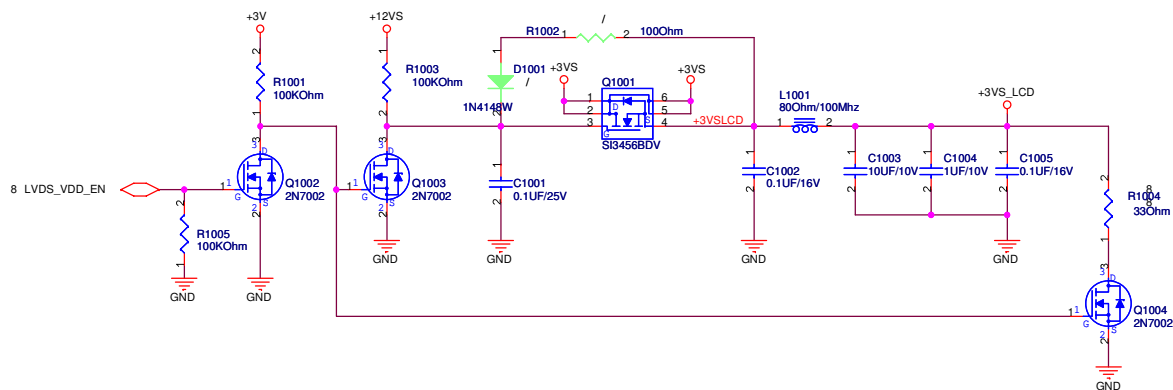

Cable Requirement:
 Impedence: 100 ohm +/- 10%
 Length Mismatch <= 10 mils
 Twisted Pair(Not Ribbon)
 Maximum Length <= 16"

LCD LVDS Interface

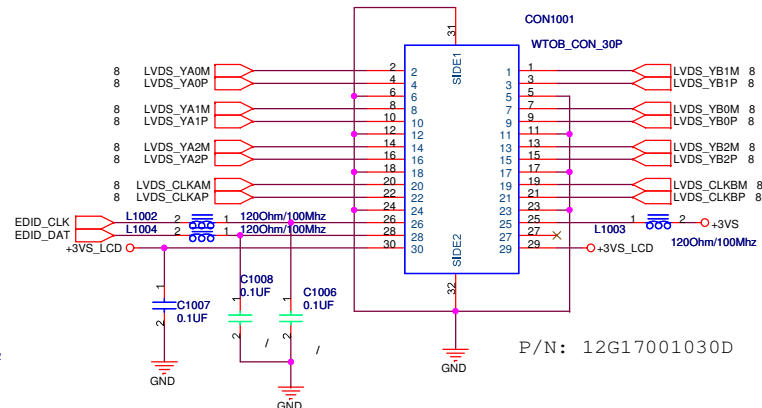

P/N: 12G17001030D

INVERTER Interface

BIOS
 BACK_OFF#:When user push "Fn+F7"
 button, BIOS active this pin to
 turn off back light.

BIOS
 INV_DA: KBC output
 D/A signal (adjust
 voltage level) to
 adjust Back light.

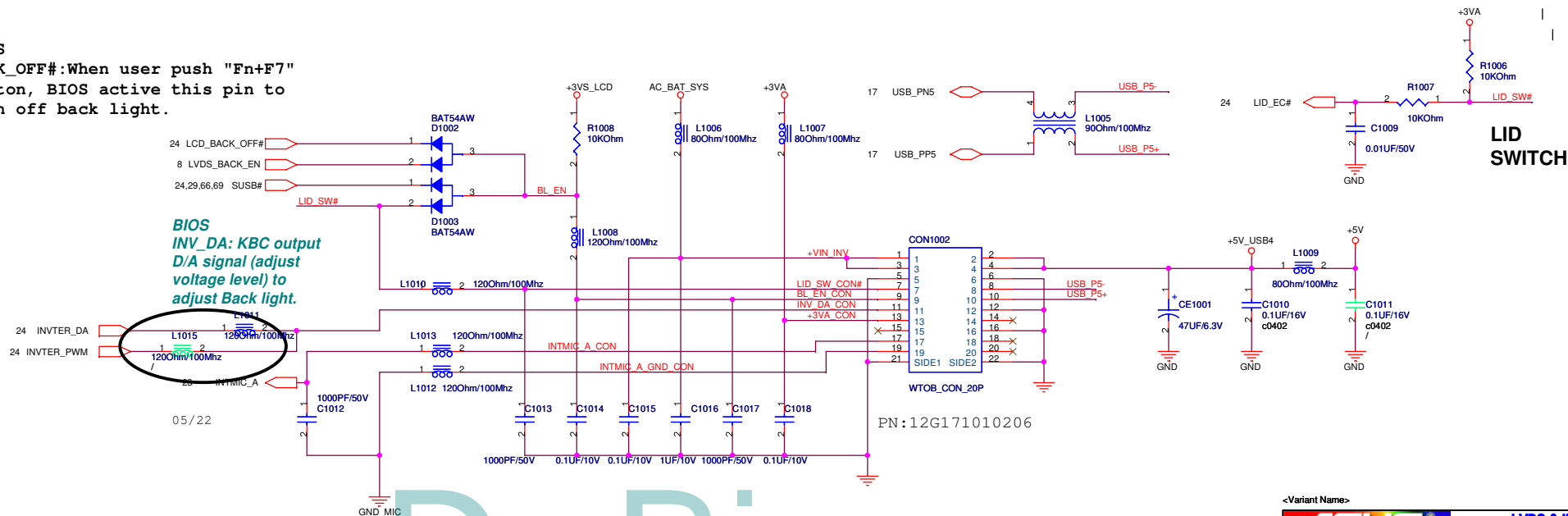

PN:12G171010206

Dr-Bios.com

ASUS		Title : LVDS & INVERTER	
ASUSTeK COMPUTER INC		Engineer: Chris_Liu, Andy_Guo	
Size	Project Name	Rev	
Custom	F5R	2.0	
Date: 2006.11.11	Sheet	10 of 71	

R1.1

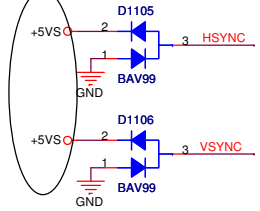

PLACE ESD Diodes near VGA port

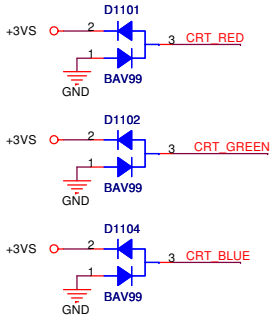

R2.0

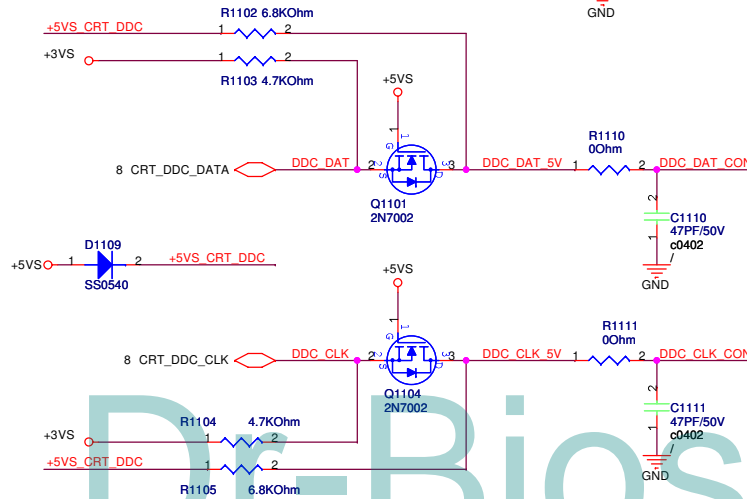
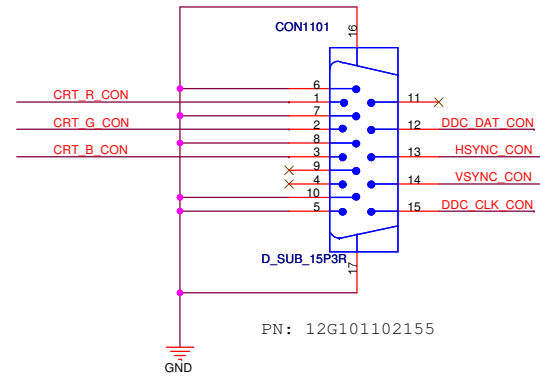
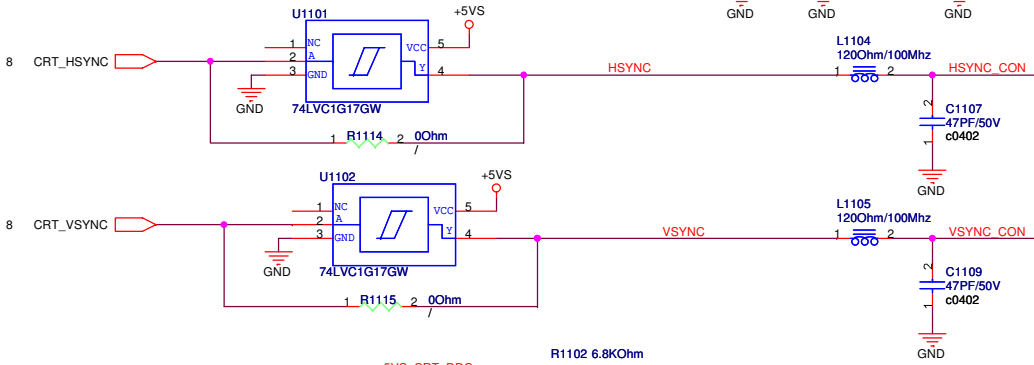
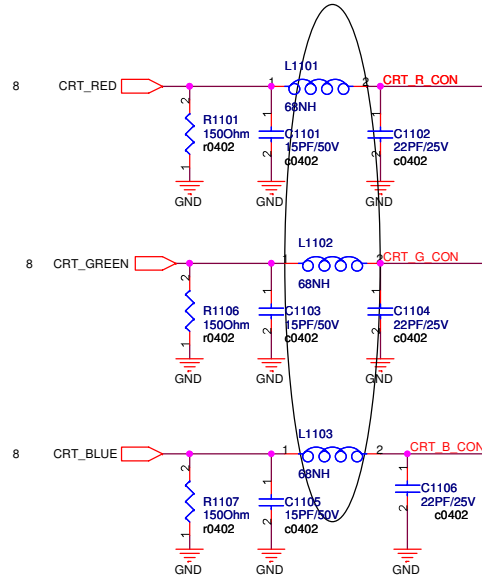

Dr-Bios.com

<Variant Name>

ASUS		Title : CRT	
ASUSTeK COMPUTER INC		Engineer: <i>Chris Liu, Andy Guo</i>	
Size	Project Name	Rev	2.0
Custom	F5R	Date:	星期三, 十月 11, 2006
Date: 星期三, 十月 11, 2006		Sheet	11 of 71

TOP

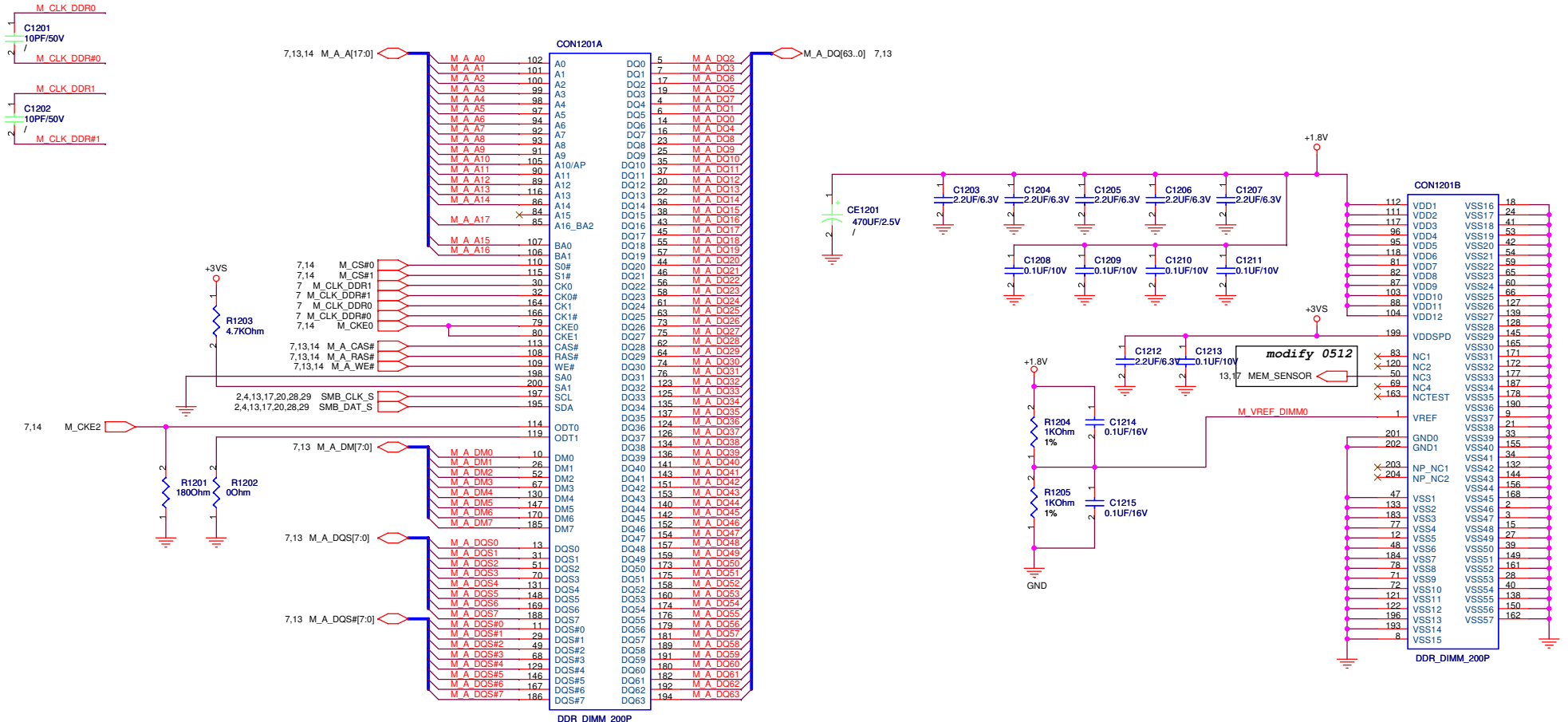

PN:12G025122006

modify 05/24



<Variant Name>

ASUS Title : **DDR2 SO-DIMM1**

ASUSTeK COMPUTER INC Engineer: **Chris_Liu,Andy_Guo**

Size	Project Name	Rev
Custom	F5R	2.0

Date: 星期五, 十月 11, 2006 Sheet 12 of 71

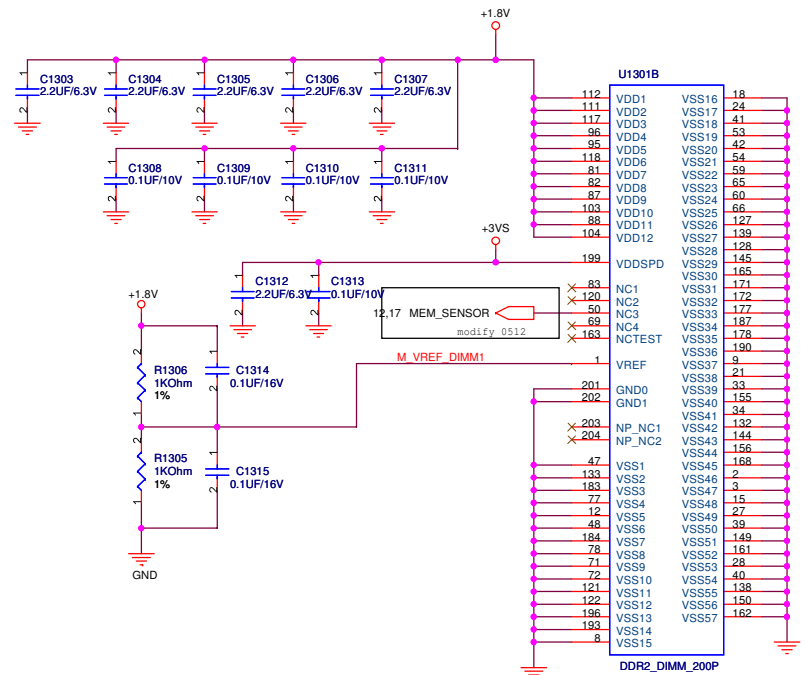
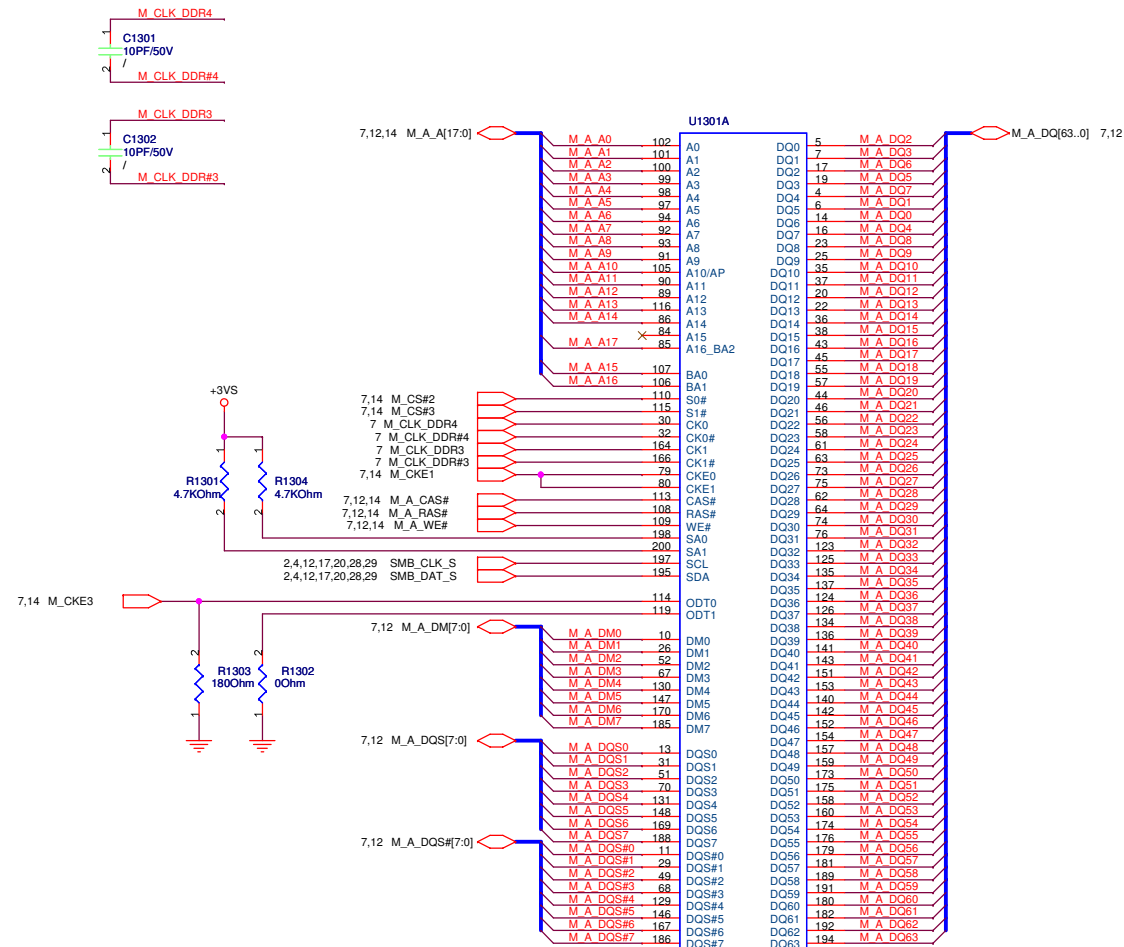

PN:12G025C22002 REV.



<Variant Name>

ASUS Title : **DDR2 SO-DIMM1**

ASUSTeK COMPUTER INC Engineer: **Chris_Liu, Andy_Guo**

Size	Project Name	Rev
Custom	F5R	2.0
Date: 星期三, 十月 11, 2006	Sheet	13 of 71

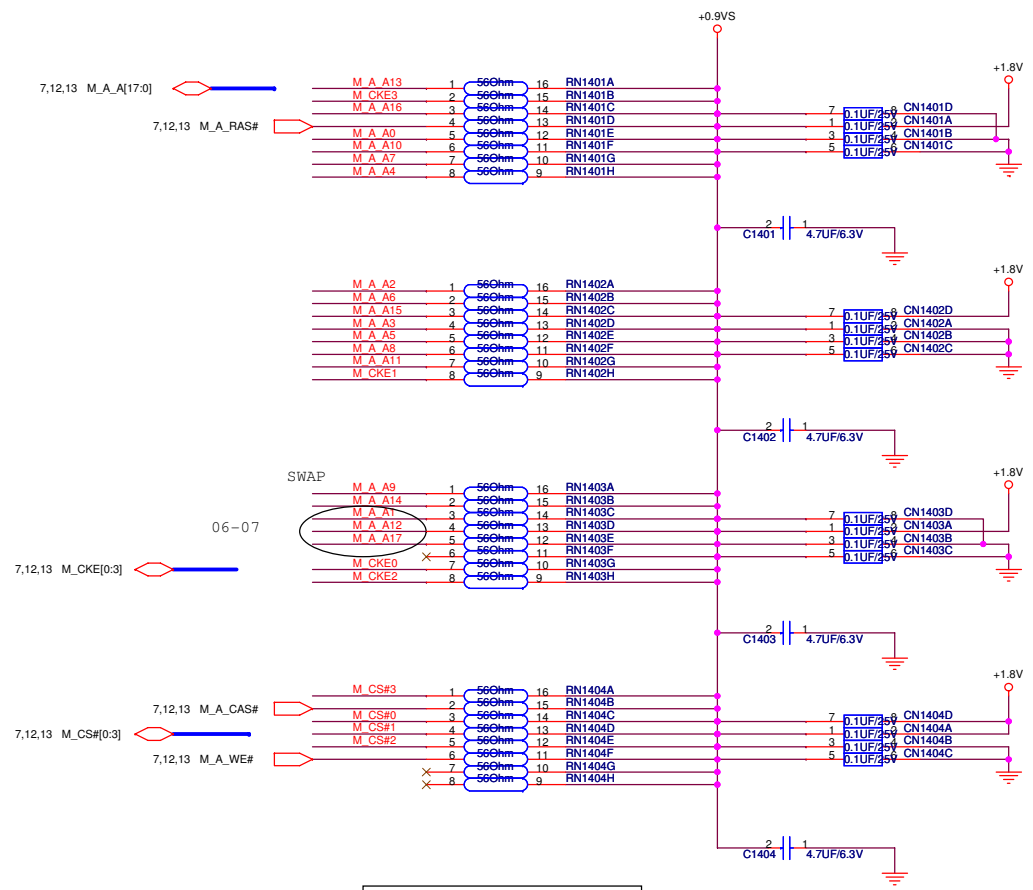

06-07

Dr-Bios.com

SB CALIBRATION RESISTOR VALUE

SB600	
R1501	562 OHM 1%
R1511	2.05K 1%
R1512	0 ohm

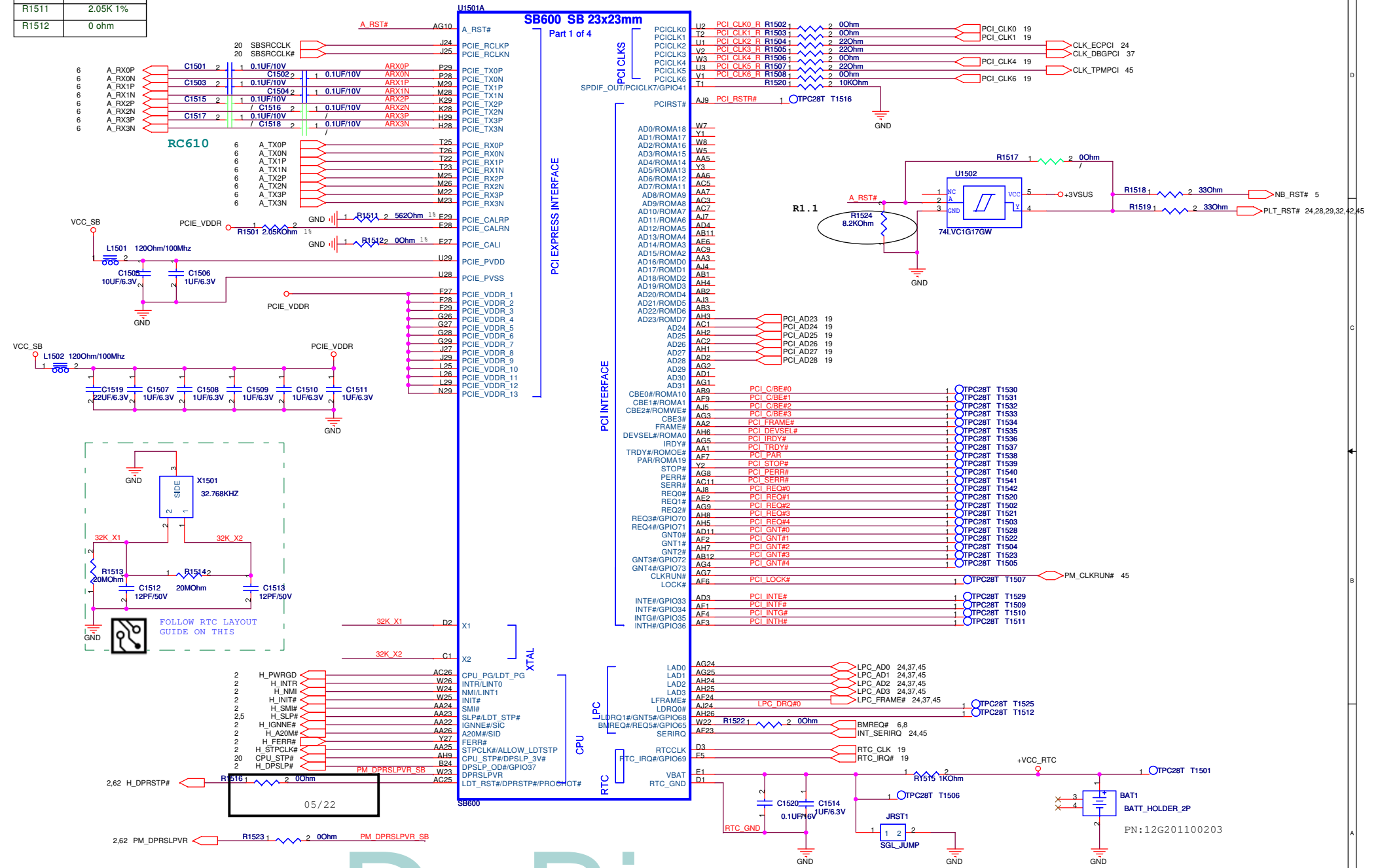

Dr-Bios.com

ASUS Title: SB600(1)
ASUSTeK COMPUTER INC Engineer: Chris Liu, Andy Guo
Size Project Name
Custom F5R
Date: 星期三, 十月 11, 2006 Sheet 15 of 71

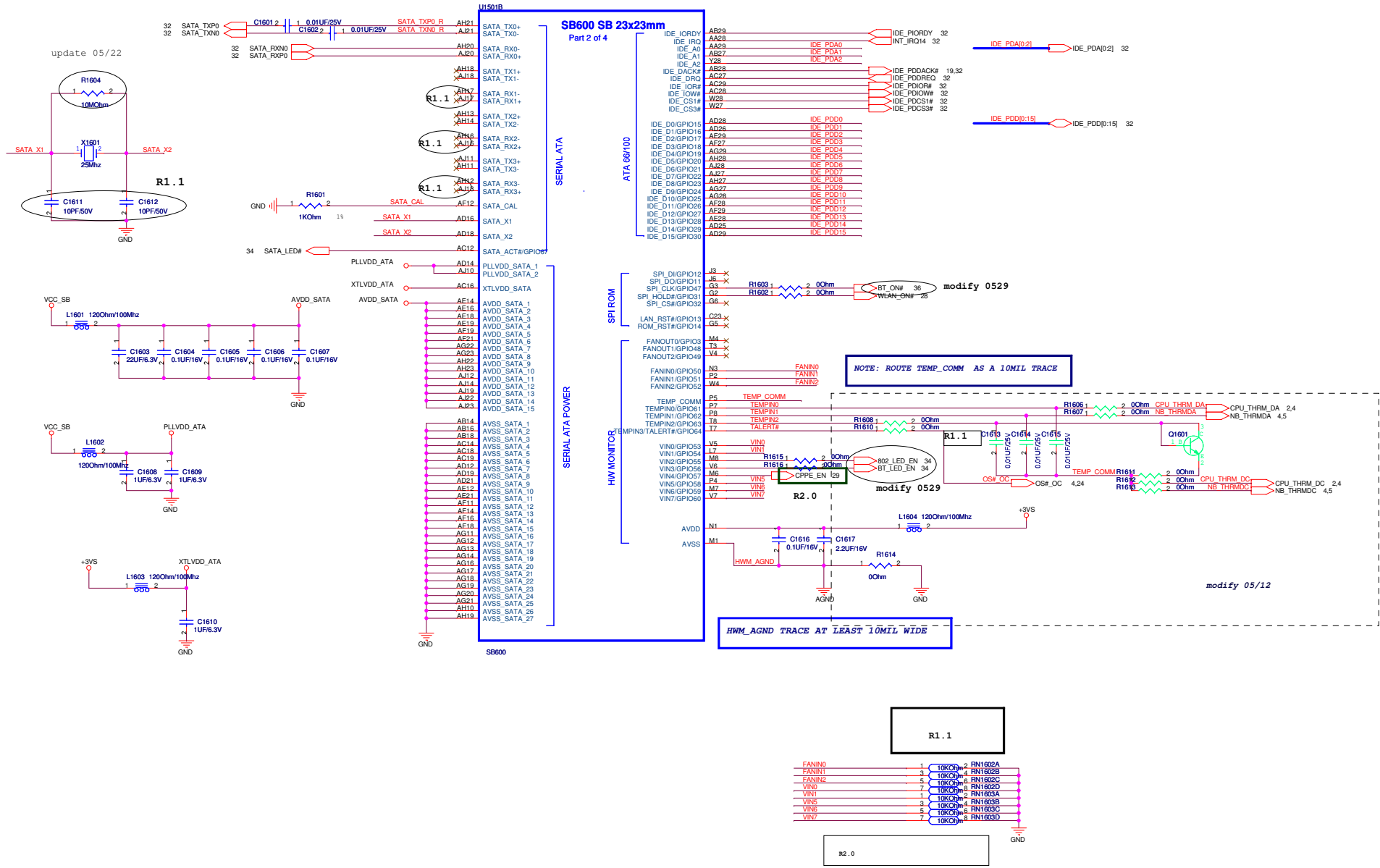

Dr-Bios.com

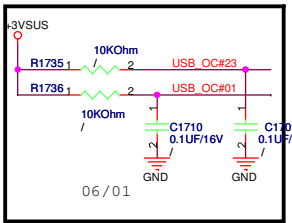
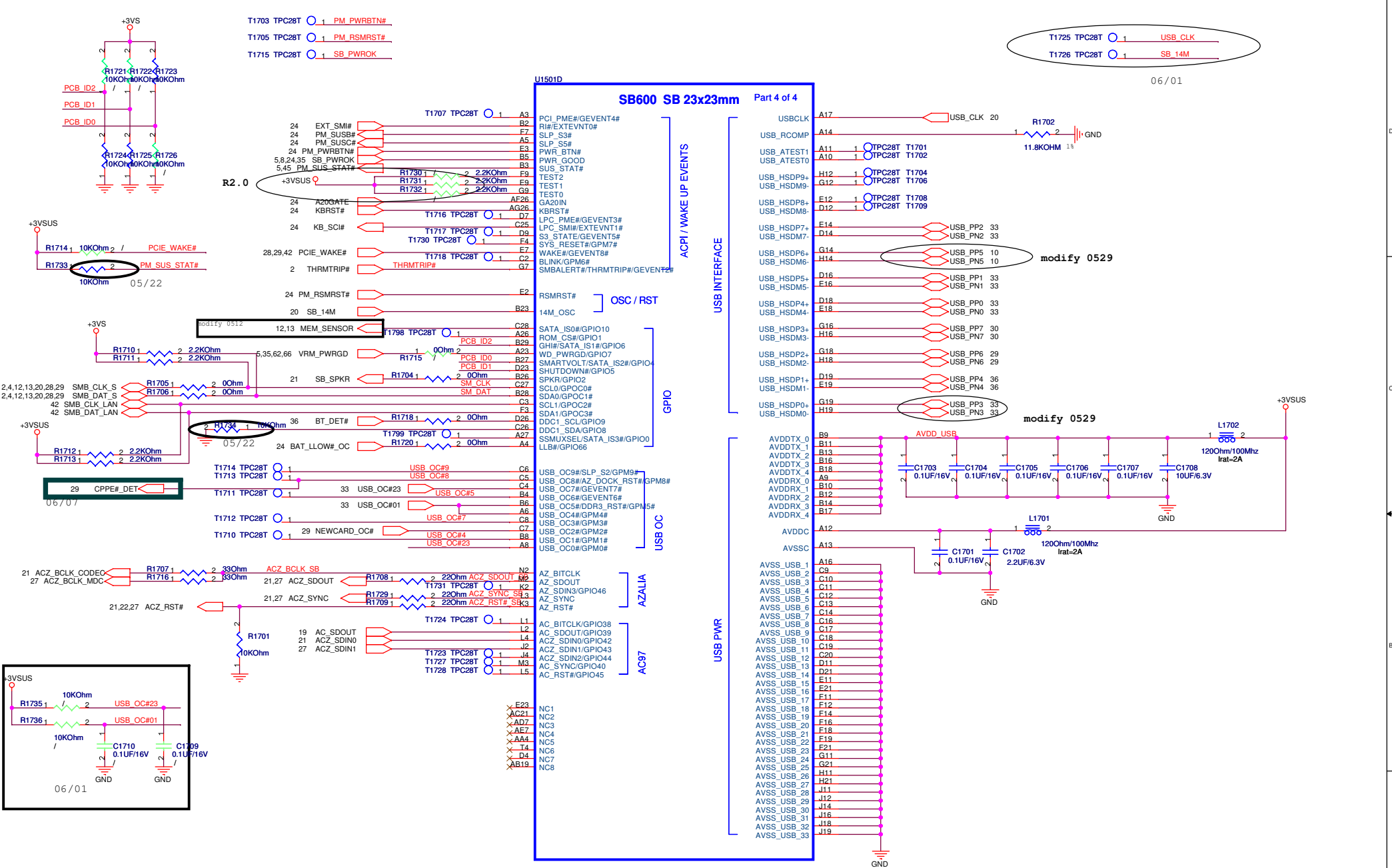

Dr-Bios.com

<Variant Name>

ASUS Title : SB600(3)

ASUSTeK COMPUTER INC Engineer: Chris_Liu,Andy_Guo

Size	Project Name	Rev
Custom	F5R	2.0
Date: 星期三, 十月 11, 2006	Sheet	17 of 71

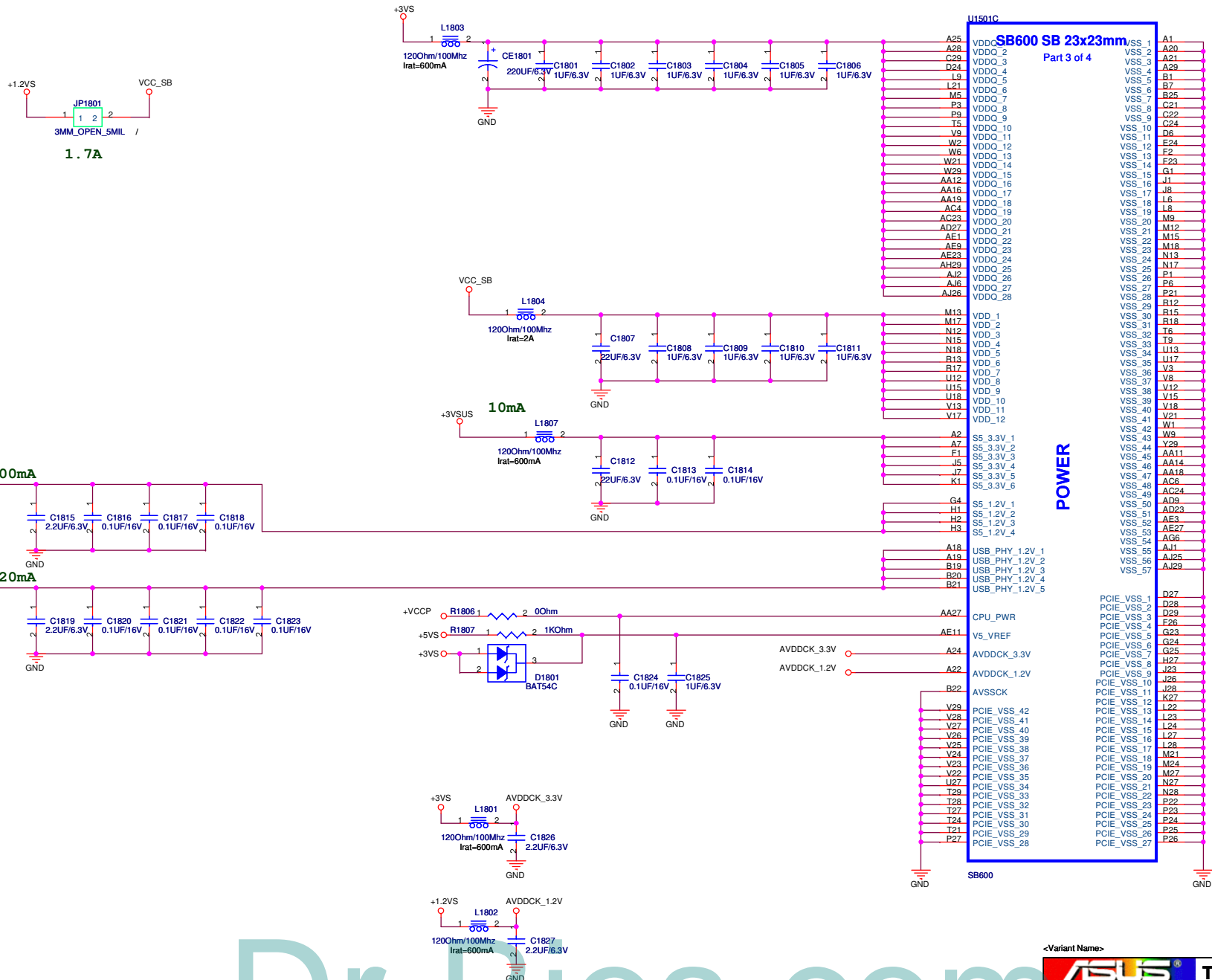

Dr-BIOS.com

<Variant Name>

ASUS		Title : SB600(PWR)	
ASUSTeK COMPUTER INC		Engineer: Chris Liu, Andy Guo	
Size	Project Name		Rev
Custom	F5R		2.0
Date: 星期三, 十月 11, 2006		Sheet	18 of 71

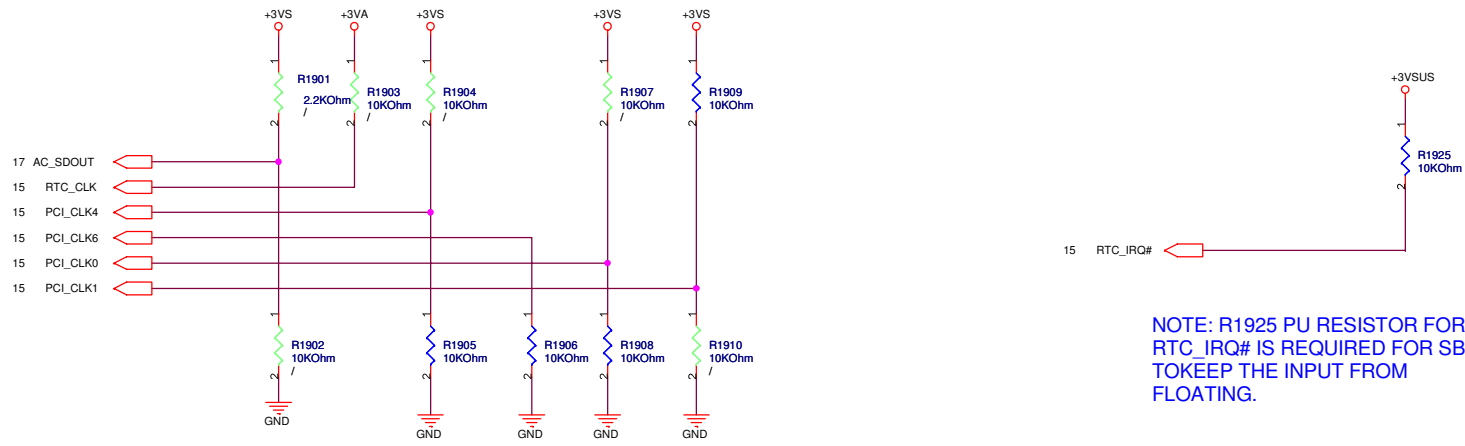

NOTE: R1925 PU RESISTOR FOR RTC_IRQ# IS REQUIRED FOR SB600 TO KEEP THE INPUT FROM FLOATING.

REQUIRED STRAPS

	SB600				SB460			
	AC_SDOUT	RTC_CLK	PCI_CLK4	PCI_CLK6	PCI_CLK0	PCI_CLK1	PCI_CLK0	PCI_CLK1
PULL HIGH	USE DEBUG STRAPS	INTERNAL RTC DEFAULT	USE INT. PLL48	CPU IF=K8	ROM TYPE: H, H = PCI ROM H, L = SPI ROM L, H = LPC ROM L, L = FWH ROM	DEFAULT	ROM TYPE: H, H = PCI ROM H, L = LPC I ROM L, H = LPC II ROM L, L = FWH ROM	DEFAULT
PULL LOW	IGNORE DEBUG STRAPS DEFAULT	EXTERNAL RTC	USE EXT. 48MHZ DEFAULT	CPU IF=P4 DEFAULT	NOTE: FOR SB460, PCICLK[8:7] ARE CONNECTED TO SUBSTRATE BALLS PCICLK[1:0]			

DEBUG STRAPS

	IDE_DACK#	PCI_AD28	PCI_AD27	PCI_AD26	PCI_AD25	PCI_AD24	PCI_AD23
PULL HIGH	USE LONG RESET DEFAULT	USE LONG RESET DEFAULT	USE PCI PLL DEFAULT	USE ACPI BCLK DEFAULT	USE IDE PLL DEFAULT	USE DEFAULT PCIE STRAPS DEFAULT	BOOTFAILTIMER DISABLED DEFAULT
PULL LOW	USE SHORT RESET	USE SHORT RESET	BYPASS PCI PLL	BYPASS ACPI BCLK	BYPASS IDE PLL	USE EEPROM PCIE STRAPS	BOOTFAILTIMER ENABLED

SB460 ONLY SB600 ONLY

SB600 ONLY
NOTE: FOR SB460, PCI_AD23 IS RESERVED

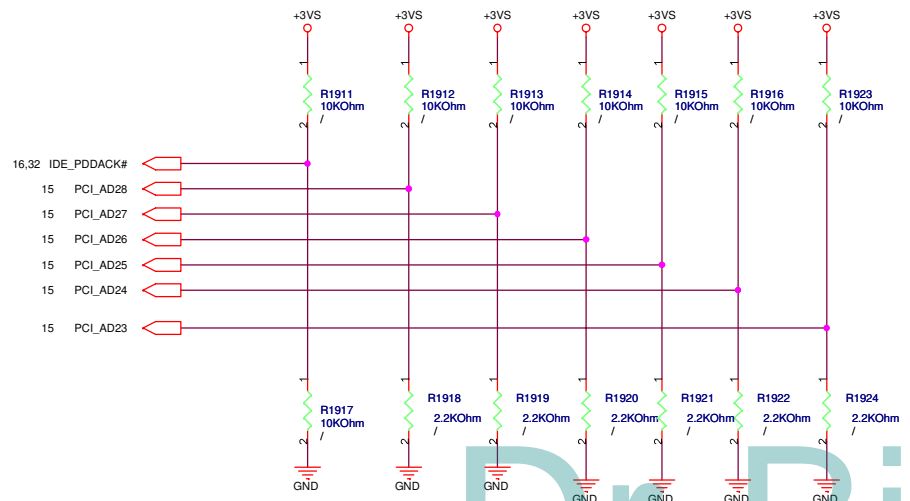

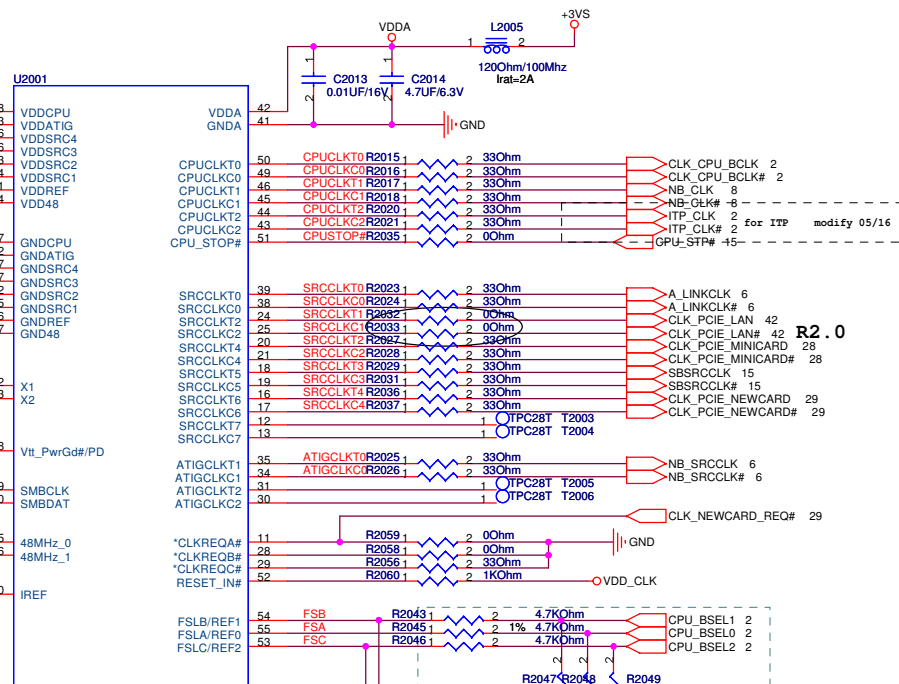
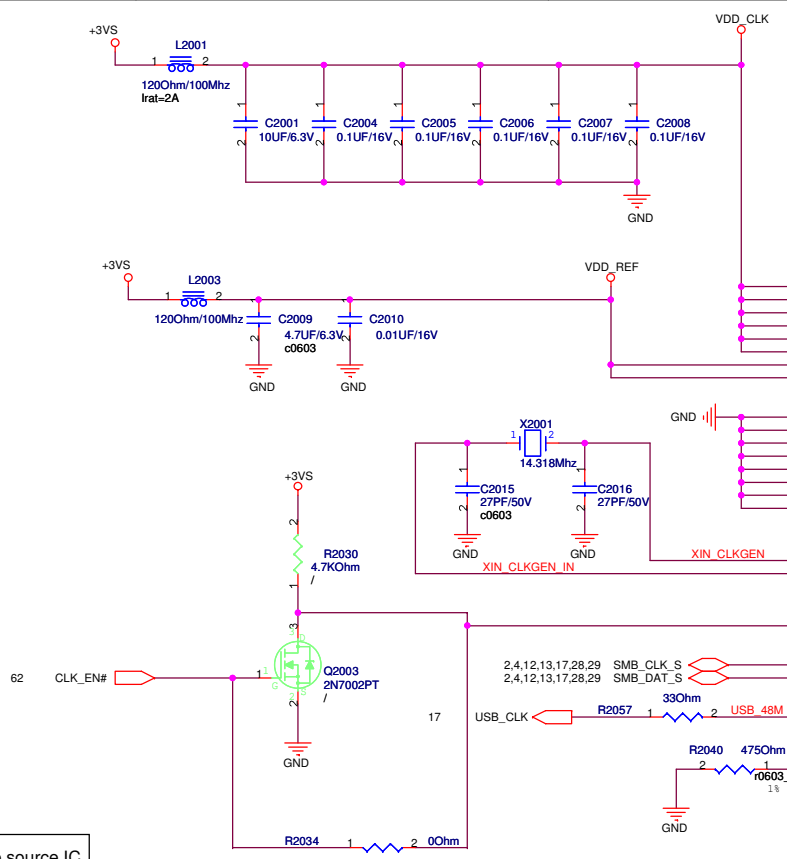

PLACE termination close to source IC

- CLK_CPU_BCLK R2001 2 49.90hm
- CLK_CPU_BCLK# R2002 2 49.90hm
- NB_CLK R2003 2 49.90hm
- NB_CLK# R2004 2 49.90hm
- A_LINKCLK R2005 2 49.90hm
- A_LINKCLK# R2006 2 49.90hm
- SBSRCCLK R2007 2 49.90hm
- SBSRCCLK# R2008 2 49.90hm
- CLK_PCIE_LAN R2009 2 100Ohm
- CLK_PCIE_LAN# R2010 2 100Ohm
- CLK_PCIE_MINICARD R2011 2 49.90hm
- CLK_PCIE_MINICARD# R2012 2 49.90hm
- CLK_PCIE_NEWCARD R2013 2 49.90hm
- CLK_PCIE_NEWCARD# R2014 2 49.90hm
- ITP_CLK R2062 2 49.90hm
- ITP_CLK# R2063 2 49.90hm
- NB_SRCLK R2019 2 49.90hm
- NB_SRCLK# R2022 2 49.90hm

R2.0

for ITP modify 05/15

BCLK	FSB	BSEL2	BSEL1	BSEL0
133	533	L	L	H
166	667	L	H	H

Dr-Bios.com

ASUS Title :CLOCK GENERATOR
 ASUSTek COMPUTER INC Engineer: Chris_Liu,Andy_Guo
 Size Project Name
 Custom F5R Rev 2.0
 Date: 星期三, 十月 11, 2006 Sheet 20 of 71

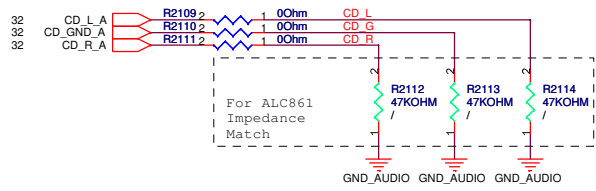
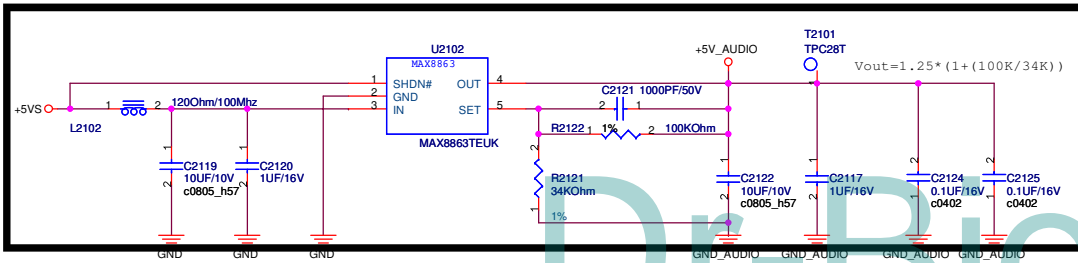
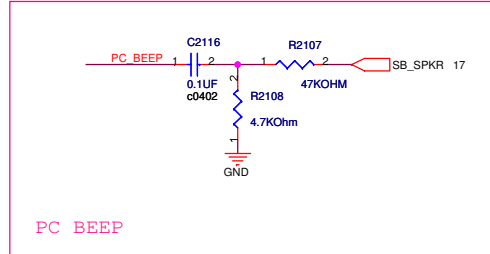
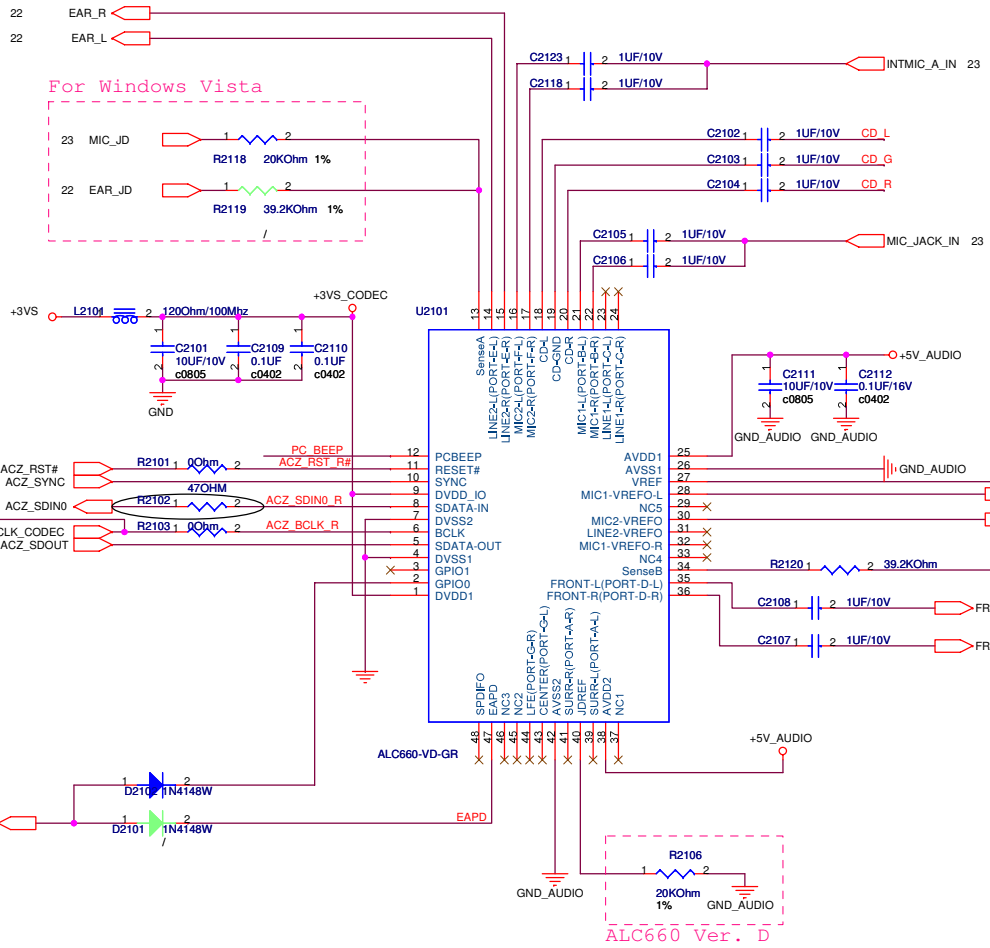

06/06 for cost down

Dr-Bios.com

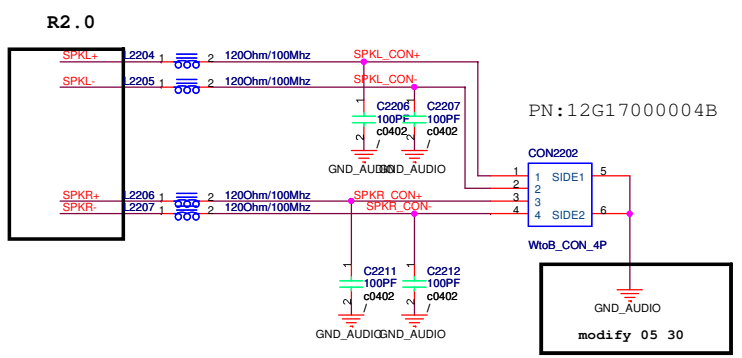
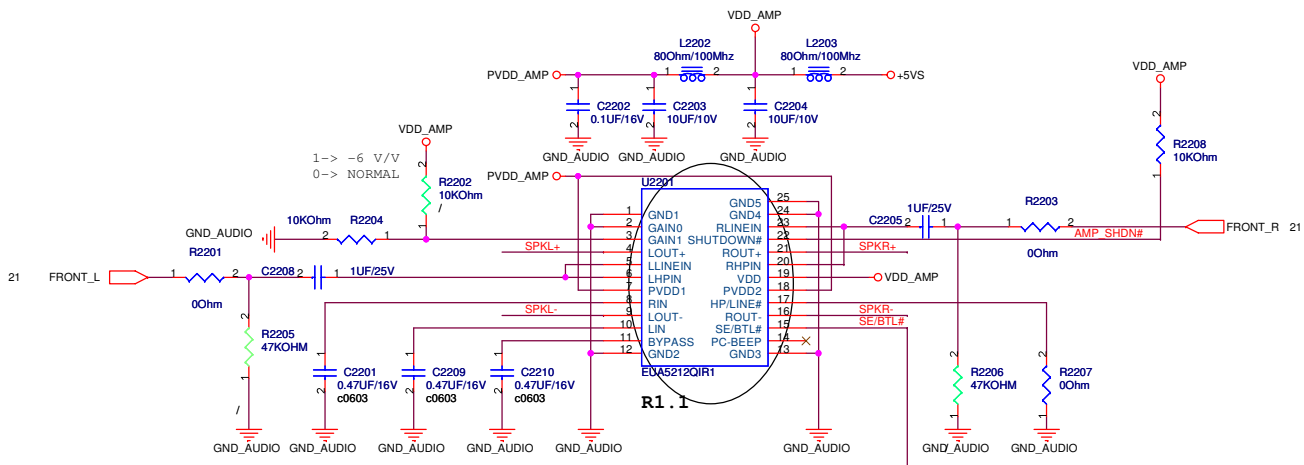

SPEAKER CONNENT

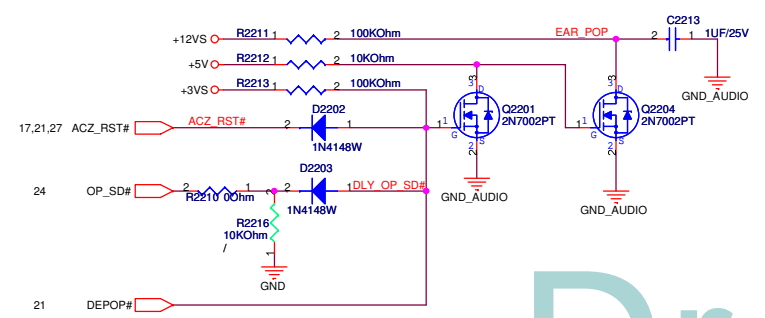
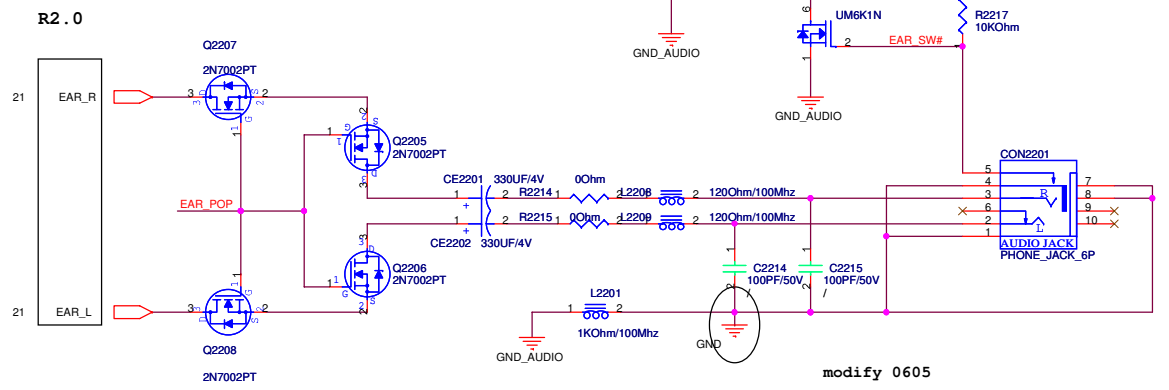
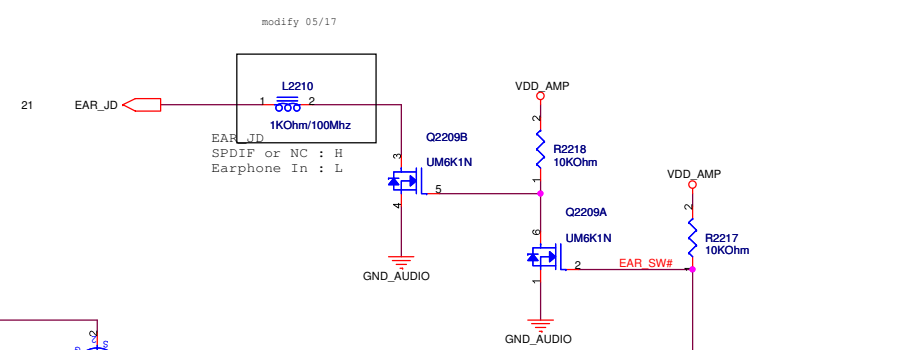
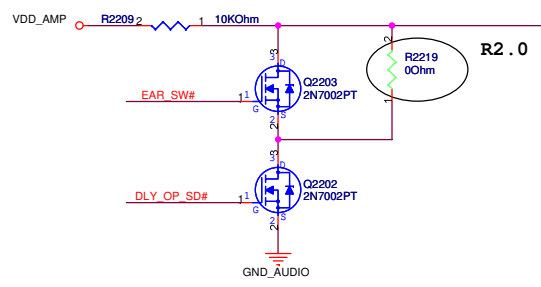

Dr-Bios.com

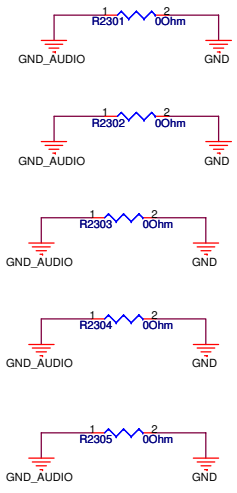

INTMIC_A:GND_AUDIO
: W/P/X = 12/5/15mils

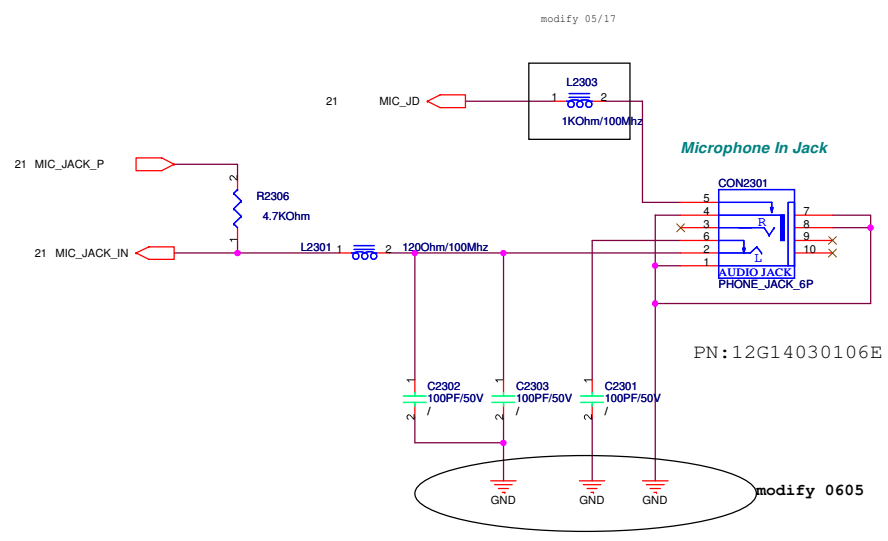
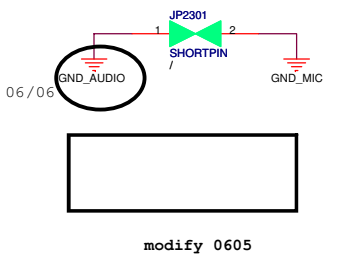

Pre-AMP For Test Function

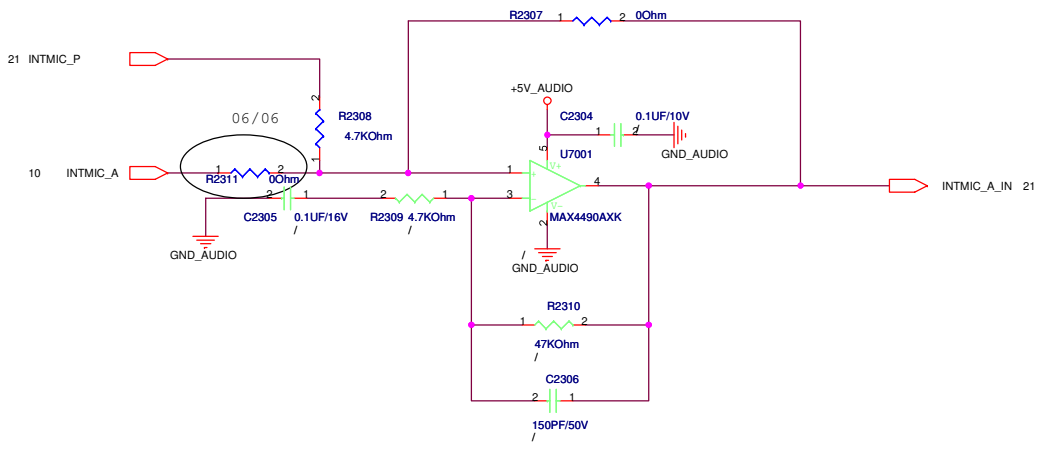

Dr-Bios.com

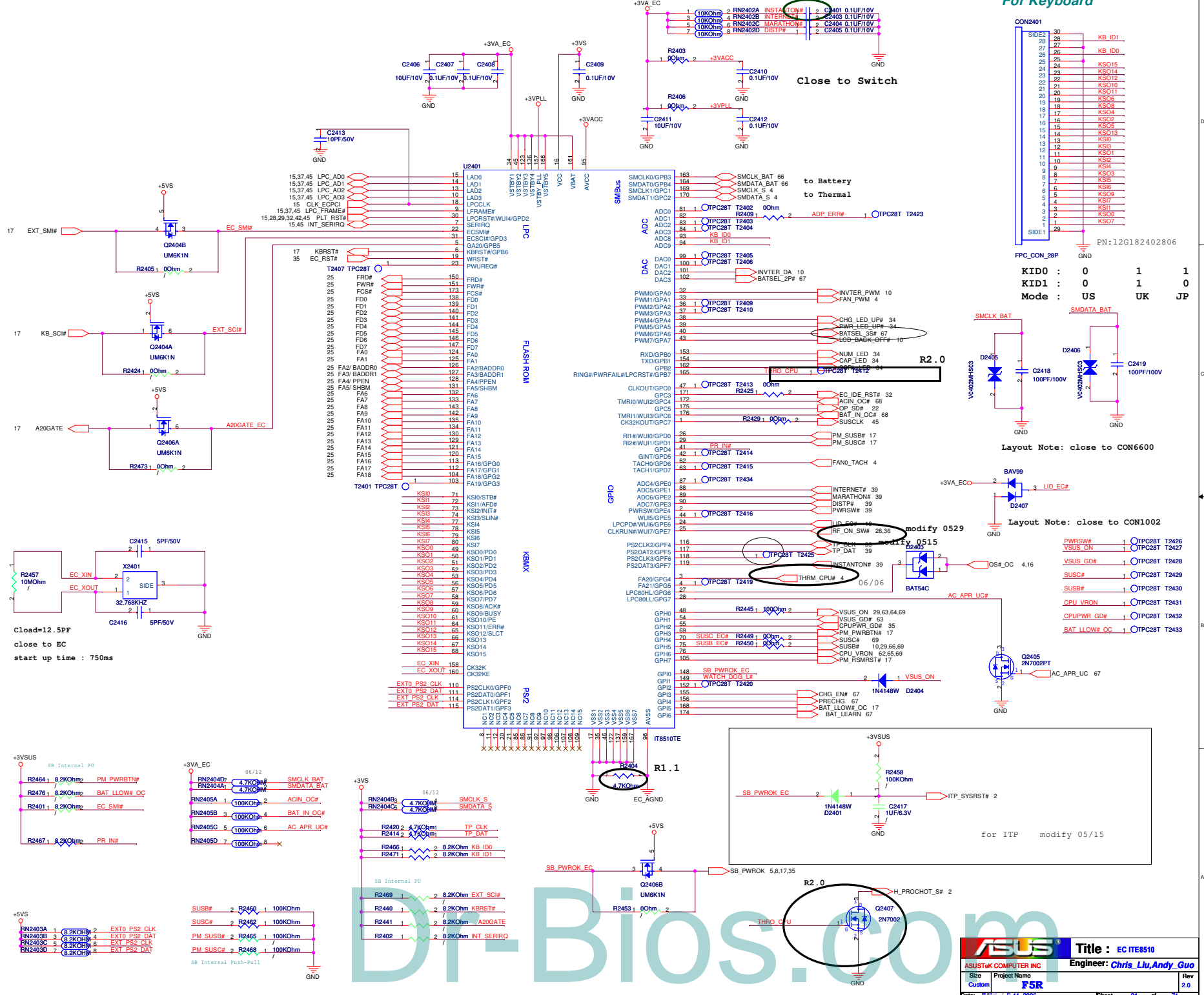

For Keyboard

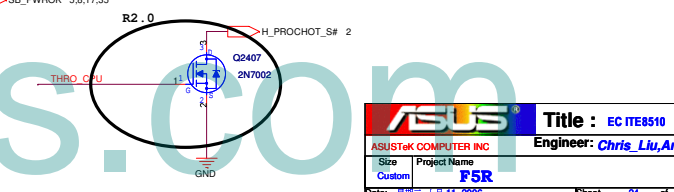
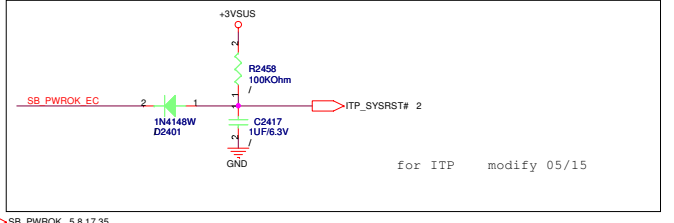
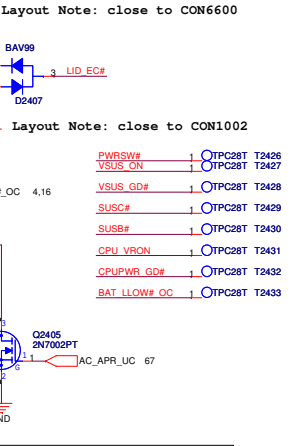
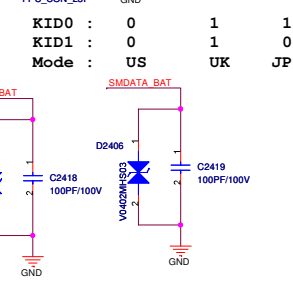
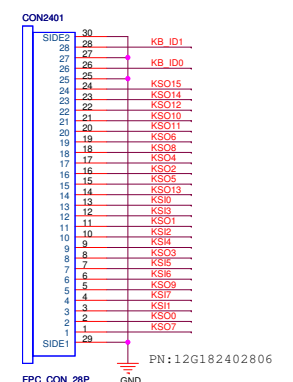

PLCC32 Socket PN:12G04300032F
 SST-PLCC32 4Mbits Flash ROM PN:05G001027221

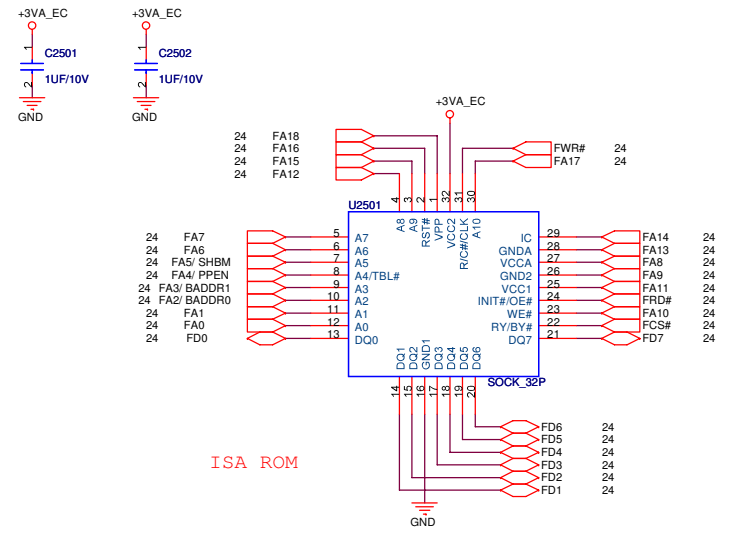

FA2/ BADDR0 & FA3/ BADDR1
 00: PNPENG Access Register Pair Are 002Eh and 002Fh
 10: PNPENG Access Register Pair Are 004Eh and 004Fh
 01: PNPENG Access Register Pair Are Determined by EC Domain Registers SWCBALR and SWCBAHR.
 11: Reserved

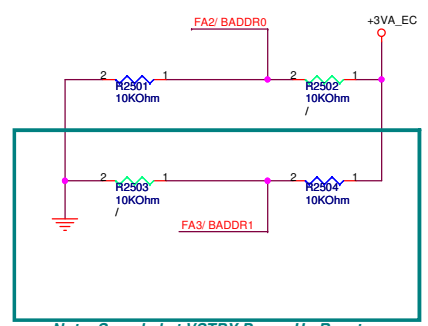

Note: Sampled at VSTBY Power Up Reset

FA5/ SHBM
 0: Disable Shared Memory with Host BIOS
 1: Enable Shared Memory with Host BIOS

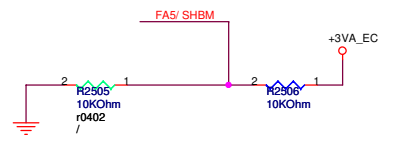

FA4/ PPEN
 0: Normal
 1: KBS Interface Pins Are Switched to Parallel Port Interface for In-System Programming

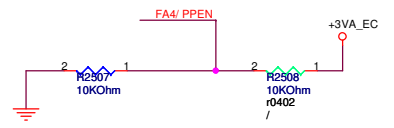

Dr-Bios.com

		Title : *
ASUSTeK COMPUTER INC		Engineer: <i>Chris Liu, Andy Guo</i>
Size	Project Name	Rev
Custom	F5R	2.0
Date: 星期三, 十月 11, 2006		Sheet 26 of 71

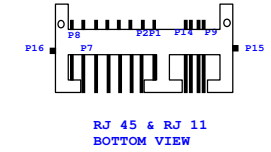
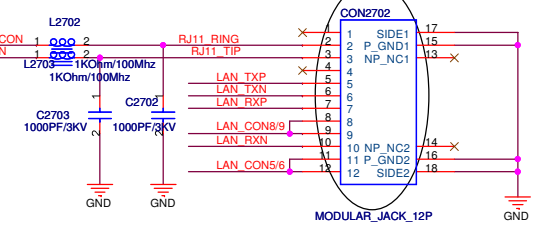
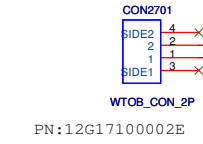
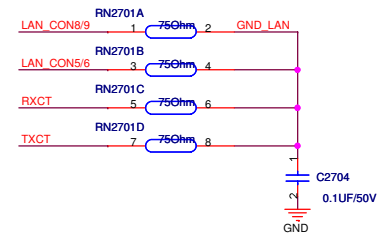
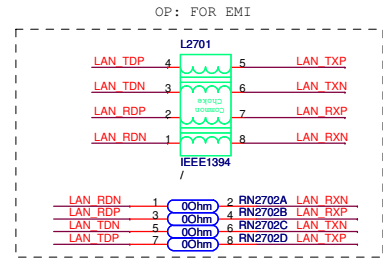
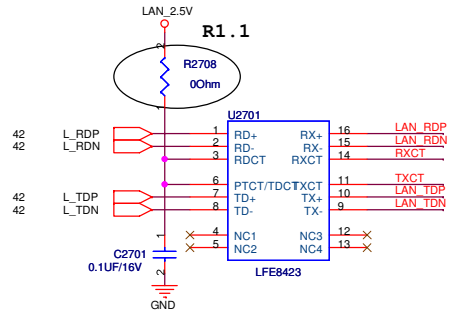

LAN PORT

MDC

MDC

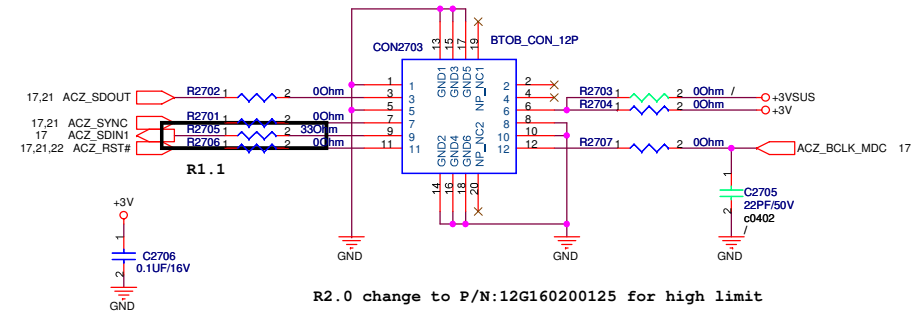

R2.0 change to P/N:12G160200125 for high limit

Dr-Bios.com

ASUS		Title : RJ11+45 & MDC
ASUSTeK COMPUTER INC		Engineer: Chris_Liu,Andy_Guo
Size	Project Name	Rev
Custom	F5R	2.0
Date: 2006.10.11	Sheet	27 of 71

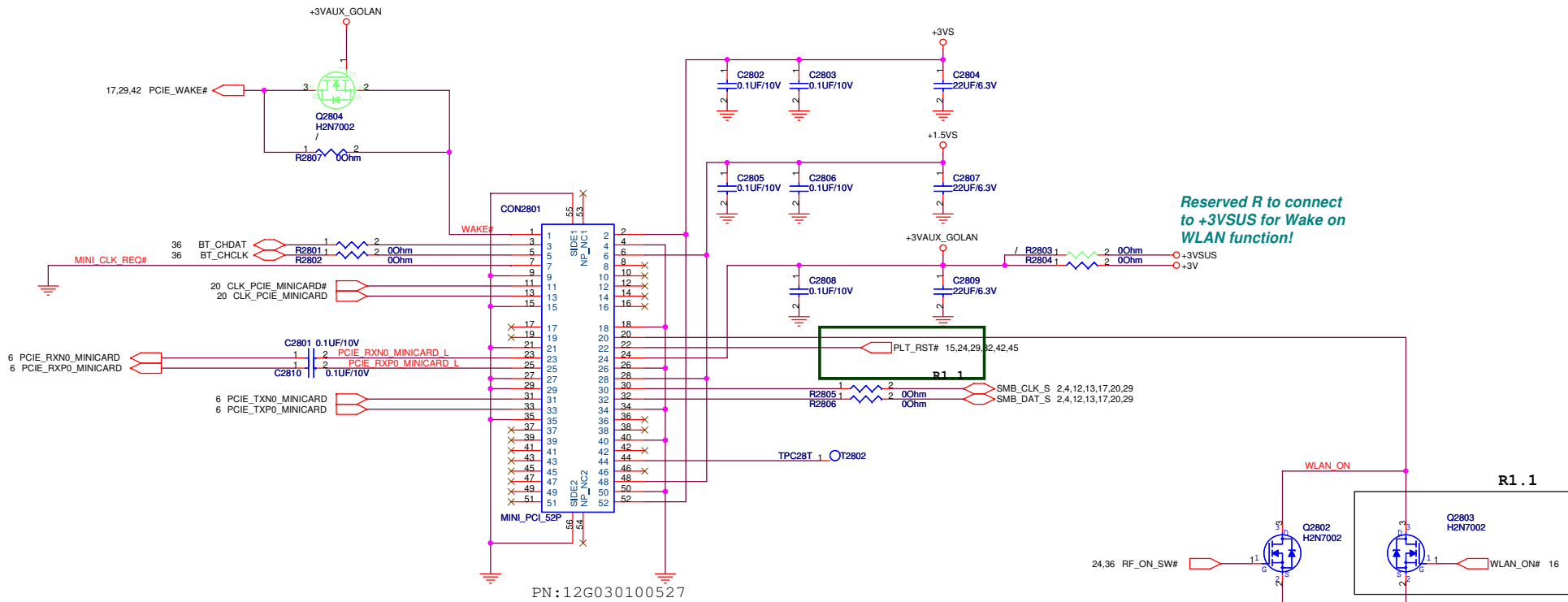

Reserved R to connect to +3VSUS for Wake on WLAN function!

PN:12G030100527

Dr-Bios.com

ASUS		Title : MINICARD	
ASUSTeK COMPUTER INC		Engineer: Chris Liu, Andy Guo	
Size	Project Name		Rev
Custom	F5R		2.0
Date: 星期三, 十月 11, 2006		Sheet	28 of 71

FOR SWAP

modify 0607

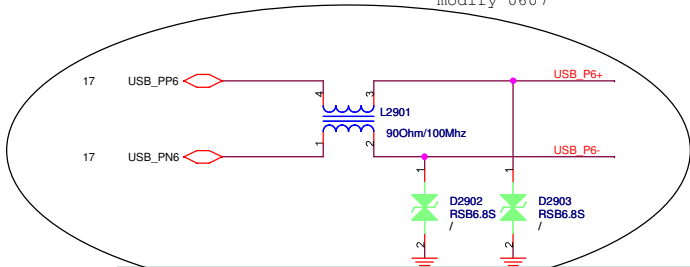

06/07

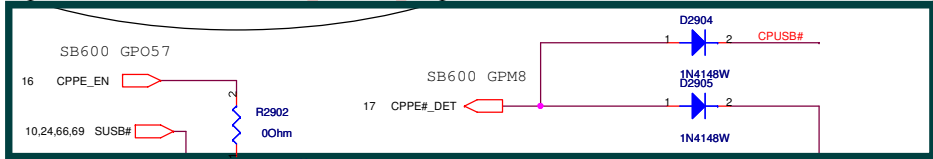

!ExpressCard Standard 1.0:
 Change Pin7 from RESERVED to SMBCLK
 Change Pin8 from SMBCLK to SMBDATA
 Change Pin9 from SMBDATA to +1.5V

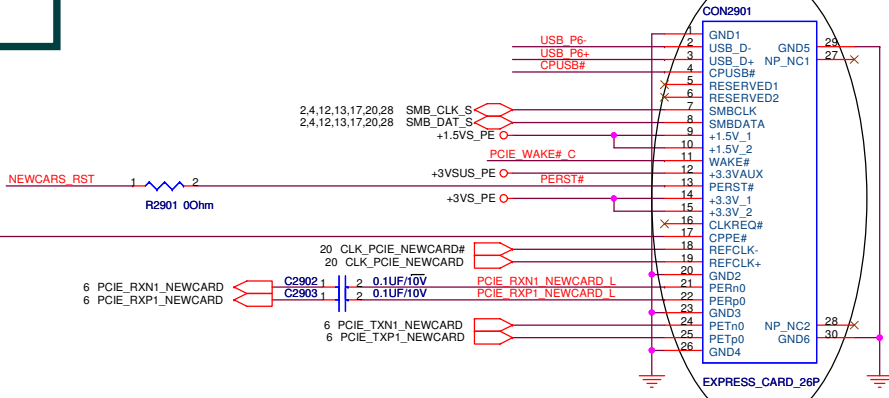
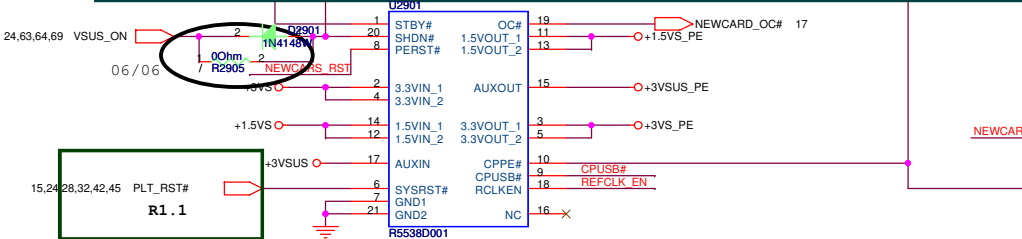

PN:12G161300261

06/07

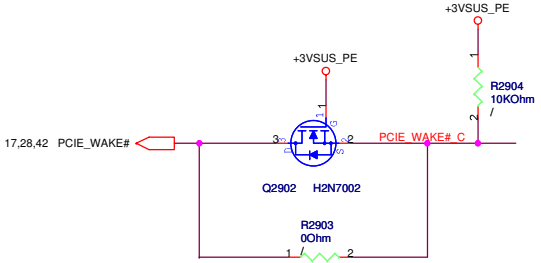
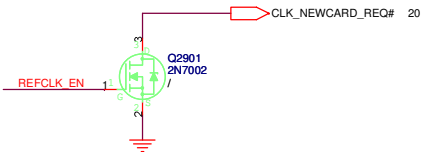

PN:12G21C102604

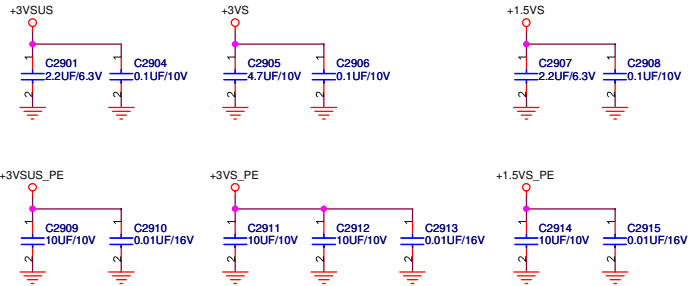

Dr-Bios.com

ASUS		Title : NEWCARD	
ASUSTeK COMPUTER INC		Engineer: Chris Liu, Andy Guo	
Size	Project Name	Rev	
Custom	F5R	2.0	
Date: 2006年11月11日		Sheet	29 of 71

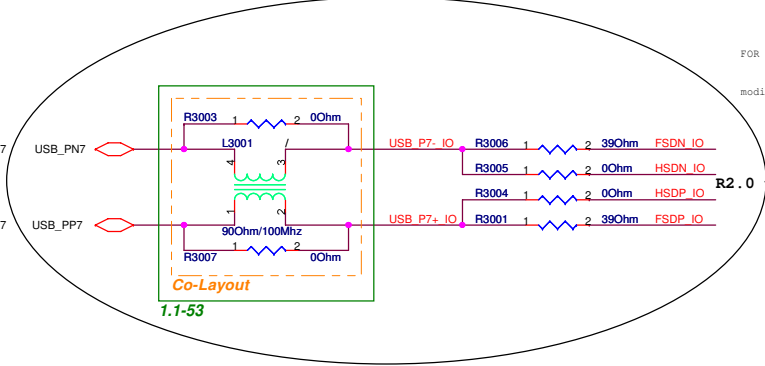

FOR SWAP
modify 0601

R2.0 update IC version P/N:02G611002510

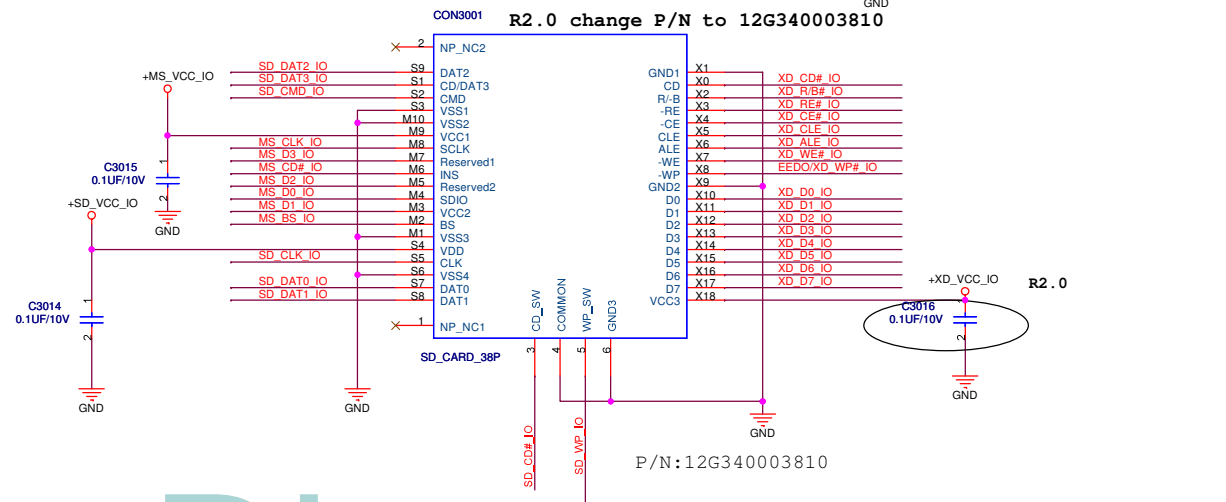
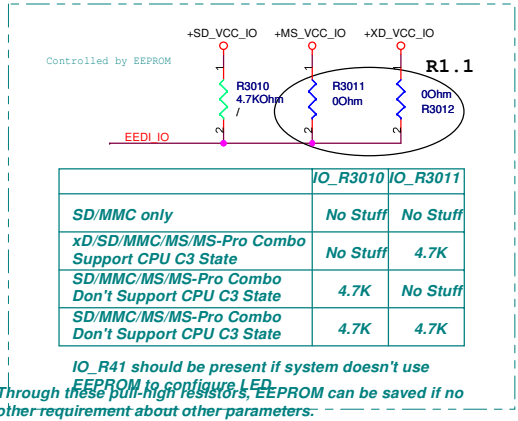
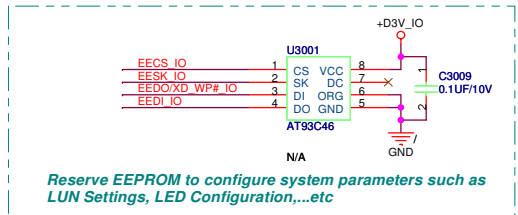
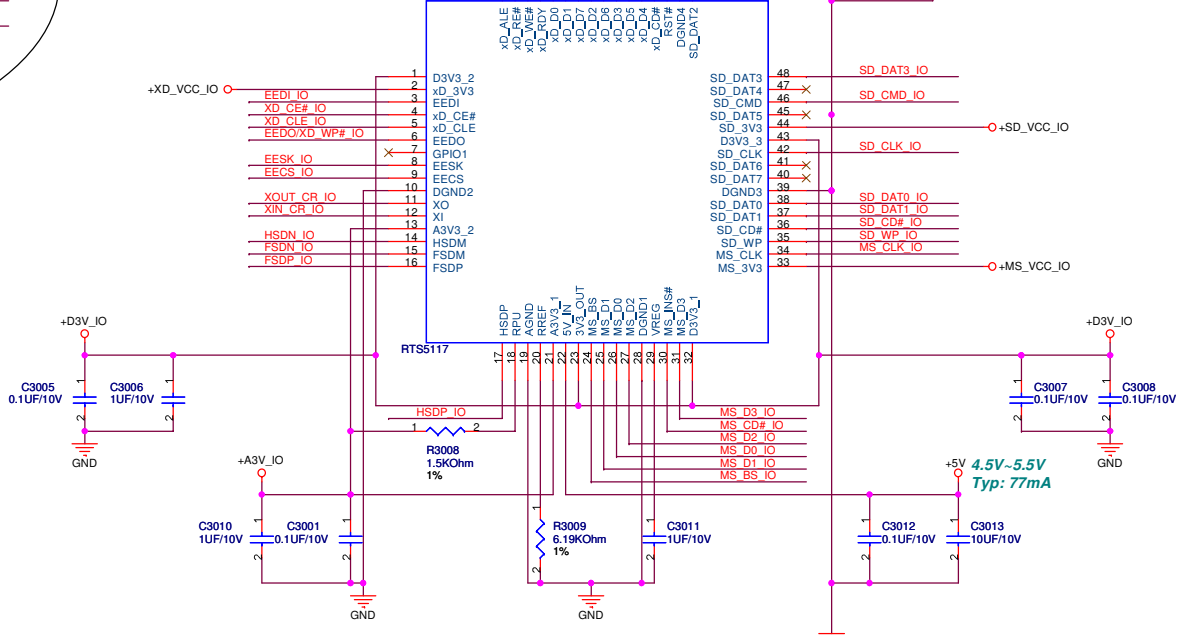

P/N:12G340003810

Dr-Bios.com

<Variant Name>

ASUS Title :CARD READER
ASUSTeK COMPUTER INC Engineer: Chris_Liu,Andy_Guo

Size Project Name
Custom **F5R**

Date: 星期三, 十月 11, 2006 Sheet 30 of 71 Rev 2.0

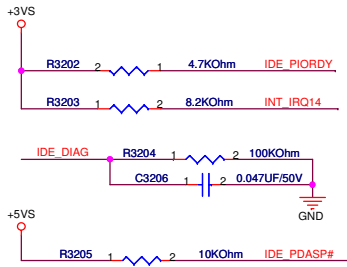

modify 0512

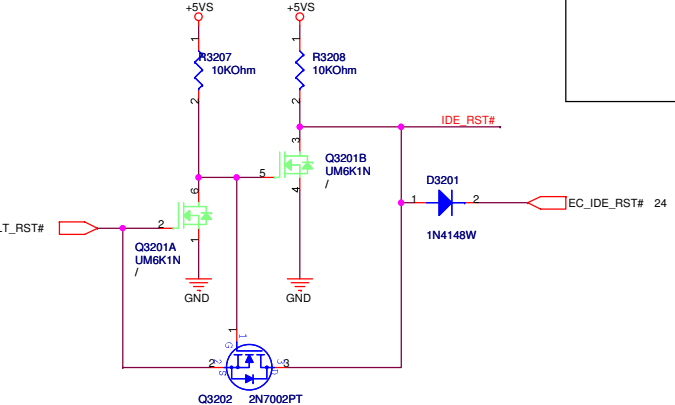
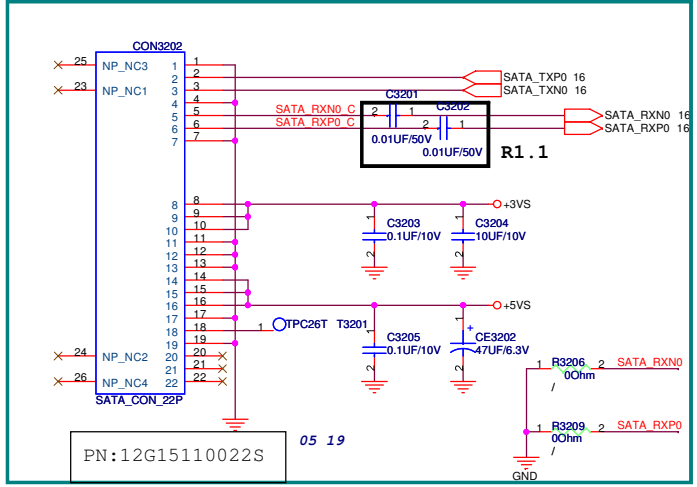

PATA

SATA

CD-ROM

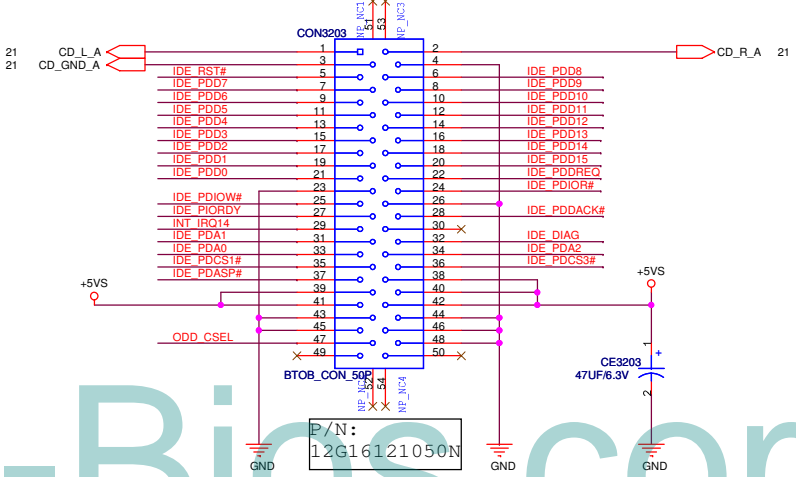
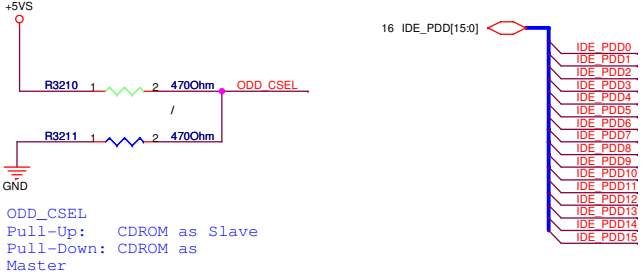

- 16 IDE_PDDREQ \leftrightarrow IDE_PDDREQ
- 16 IDE_PDIOW# \leftrightarrow IDE_PDIOW#
- 16 IDE_PDIOR# \leftrightarrow IDE_PDIOR#
- 16 IDE_PIO RDY \leftrightarrow IDE_PIO RDY
- 16,19 IDE_PDDACK# \leftrightarrow IDE_PDDACK#
- 16 INT_IRQ14 \leftrightarrow INT_IRQ14
- 16 IDE_PDA1 \leftrightarrow IDE_PDA1
- 16 IDE_PDA0 \leftrightarrow IDE_PDA0
- 16 IDE_PDA2 \leftrightarrow IDE_PDA2
- 16 IDE_PDCS1# \leftrightarrow IDE_PDCS1#
- 16 IDE_PDCS3# \leftrightarrow IDE_PDCS3#
- 34 IDE_PDASP# \leftrightarrow IDE_PDASP#

P/N: 12G16121050N

update 05 18

<Variant Name>

Title : HDD & CD-ROM
 ASUSTeK COMPUTER INC Engineer: **Chris Liu, Andy Guo**
 Size Project Name
 Custom **F5R** Rev 2.0
 Date: 星期三, 十月 11, 2006 Sheet 32 of 71

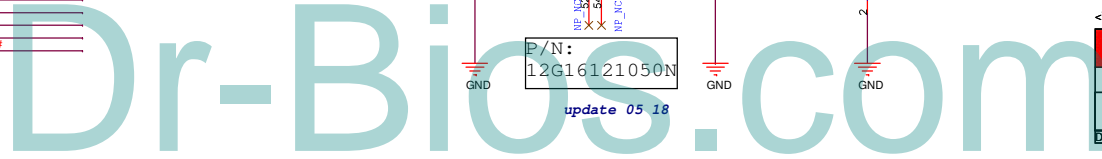

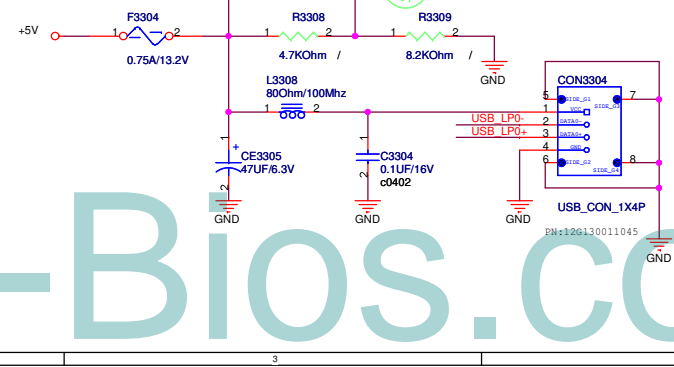
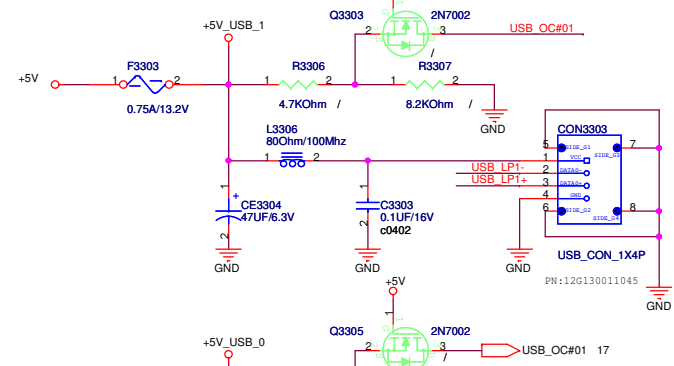
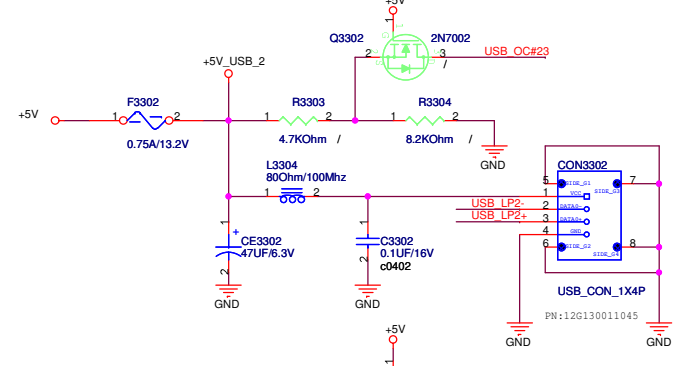
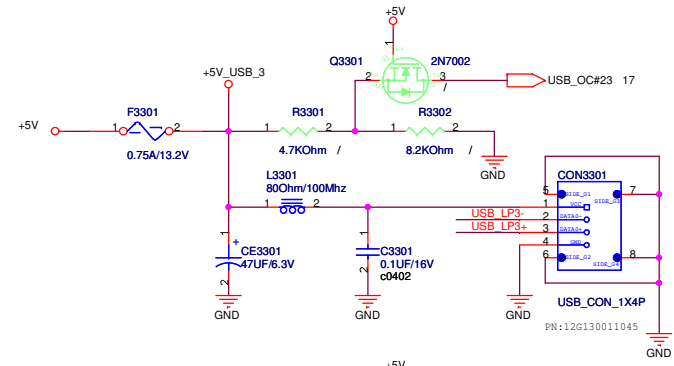
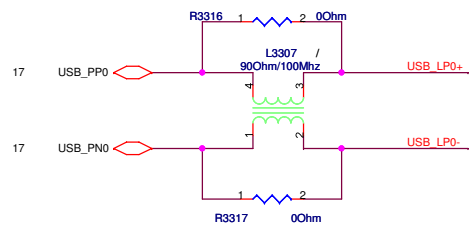
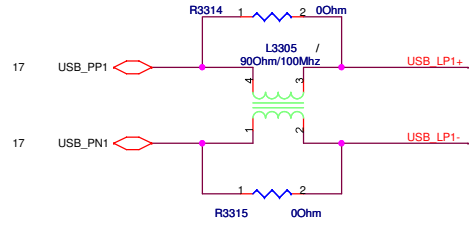
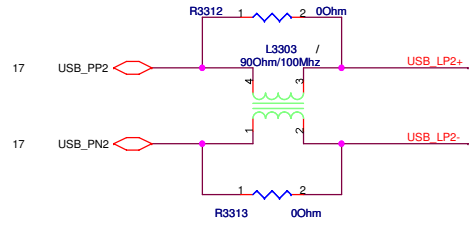
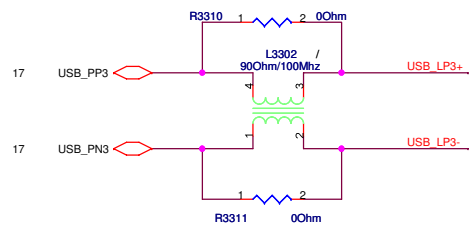

Dr-Bios.com

Title : USB CONN	
ASUSTeK COMPUTER INC	Engineer: Chris_Liu,Andy_Guo
Size Custom	Project Name F5R
Date: 星期三, 十月 11, 2006	Sheet 33 of 71

For POWER LED

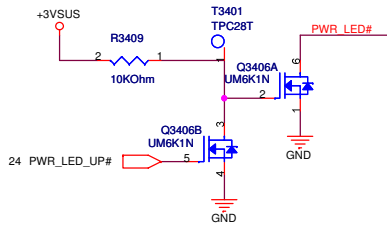
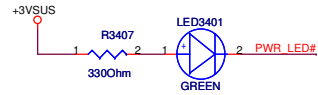

BATTERY LED

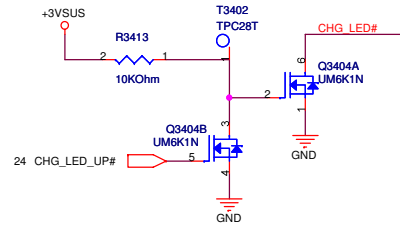
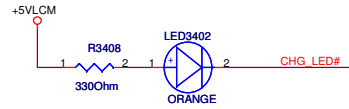

Num Lock

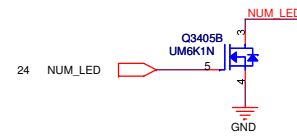
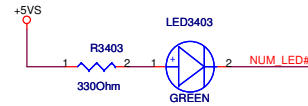

Cap Lock

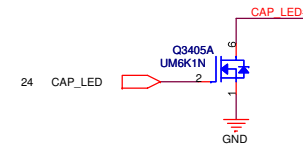
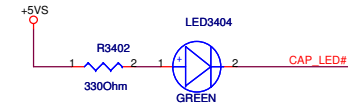

SATA/IDE LED

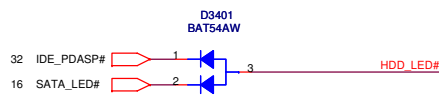
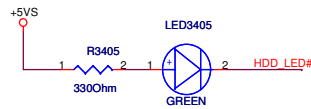

WireLess LED

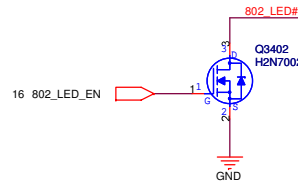
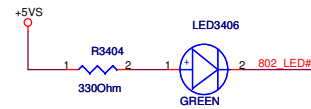

Scroll Lock

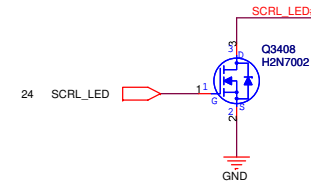
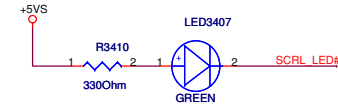

BT LED

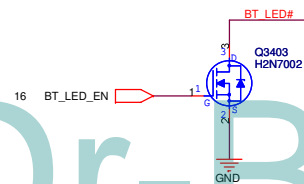
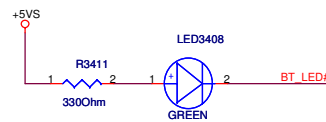

Dr-Bios.com

<Variant Name>		ASUS Title : LED	
Size	Project Name	Engineer:	Chris Liu, Andy Guo
Custom	F5R	Rev	2.0
Date: 2006年10月11日	Sheet	34	of 71

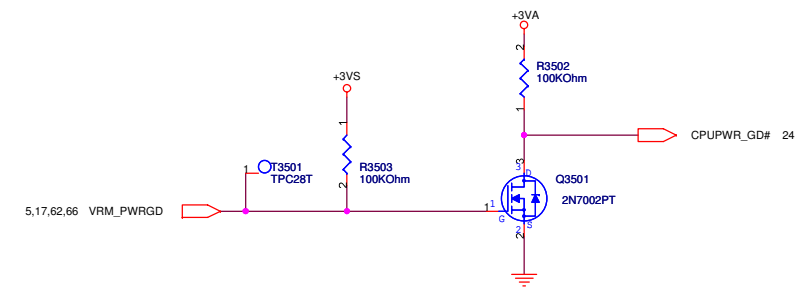
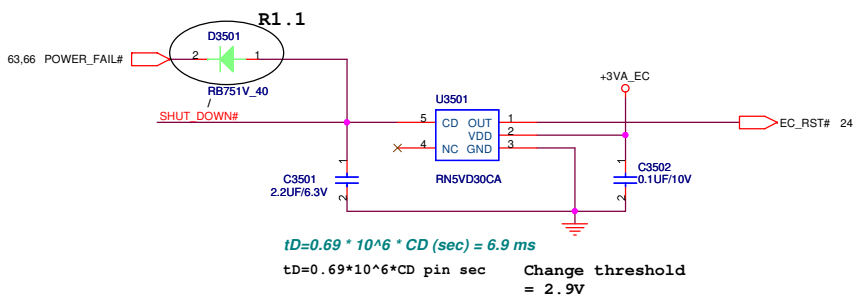

RESET SW.

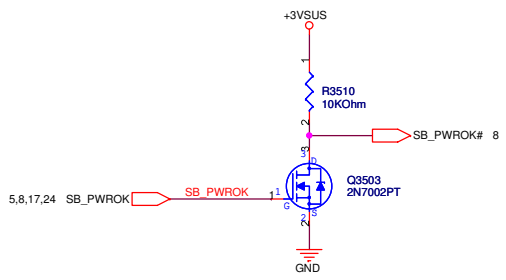
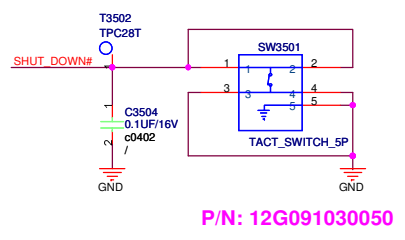

Dr-Bios.com

<Variant Name>		ASUS		Title : RST	
ASUSTeK COMPUTER INC		Engineer: Chris_Liu,Andy_Guo			
Size	Project Name	Rev			
Custom	F5R	2.0			
Date: 星期三, 11, 2006	Sheet	35	of	71	

For Bluetooth

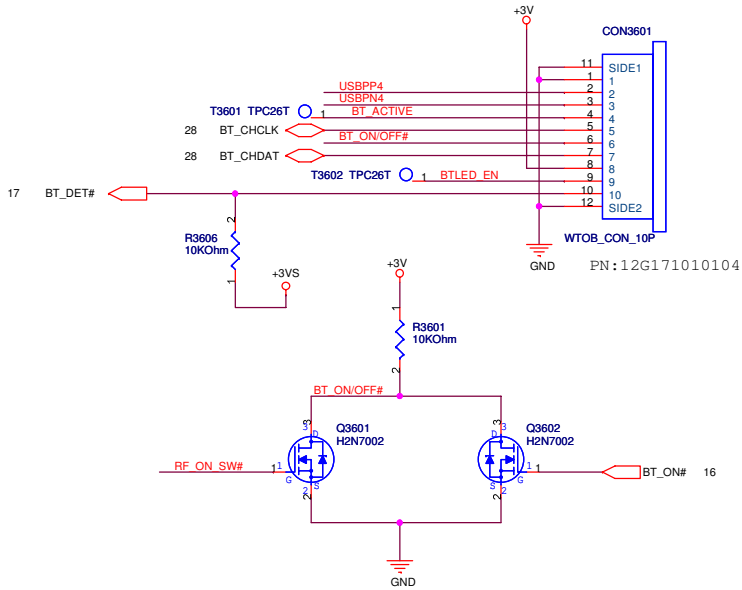

For Side SW

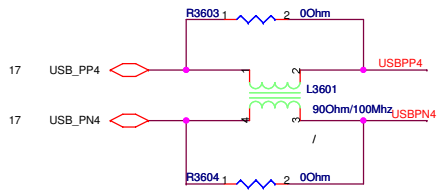
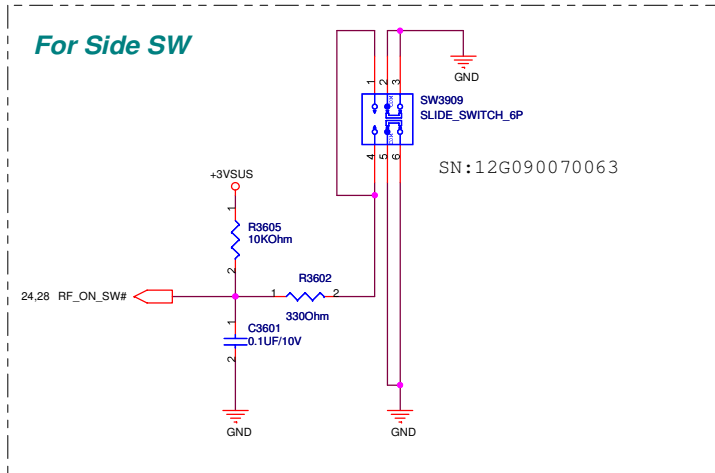

Dr-Bios.com

<Variant Name>		ASUS		Title : BlueTooth	
ASUSTeK COMPUTER INC		ASUSTeK COMPUTER INC		Engineer: <i>Chris_Liu,Andy_Guo</i>	
Size	Project Name	Rev			
Custom	F5R	2.0			
Date: 星期三, 十月 11, 2006	Sheet	36	of 71		

System Power Sequence
 +VCCRST# -> RTCRST# -> V5REFSUS -> 3.3/1.5VSUS
 RSMRST# -> SUSC# -> SUSB# -> VCCLAN -> LANPWROK
 -> V5REF -> PWROK -> GMCH -> VCCP -> VCORE
 SUSSTAT# -> PCIRST#

CPU : +VCORE, +VCCP, +1.05VS
 NB : +1.05VS, +1.2VS, +2.5V, +VCCP
 SB : +1.2VSUS, +3.3VSUS, +VCCP, +1.5VS, +3.3VS
 DDR : +1.8V, +0.9VS

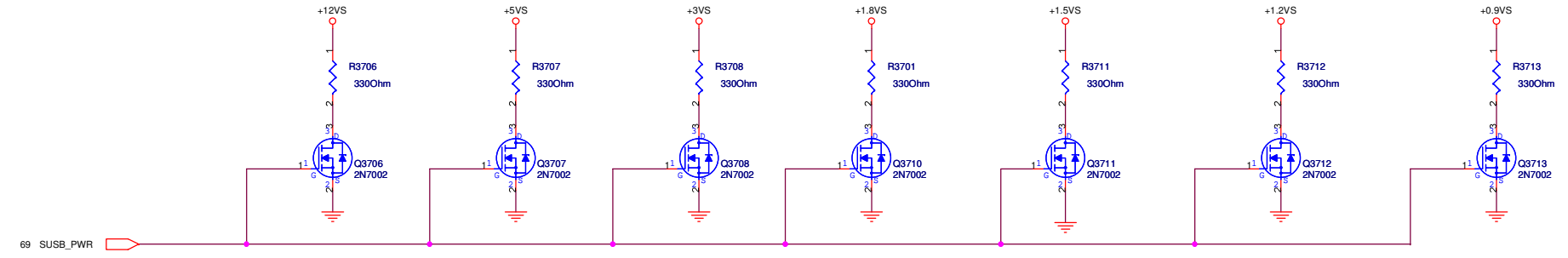
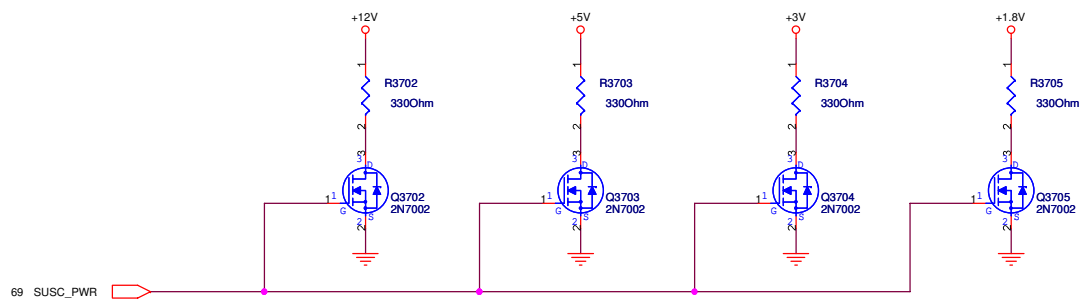

Debug Port

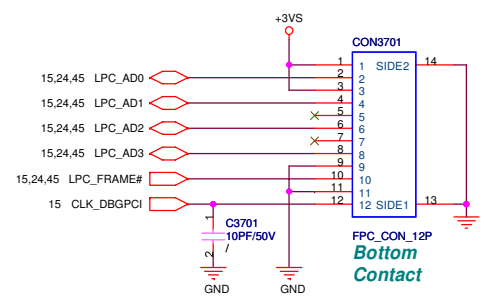

Dr-Bios.com

ASUS		Title : DISCHARGE CKT	
ASUSTeK COMPUTER INC		Engineer: Chris Liu, Andy Guo	
Size	Project Name	Rev	
Custom	F5R	2.0	
Date: 星期三, 十月 11, 2006		Sheet	37 of 71

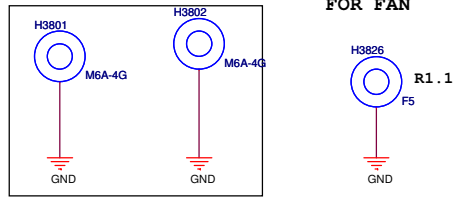
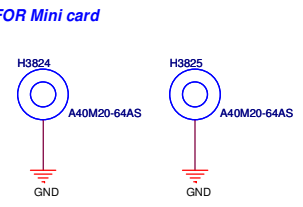
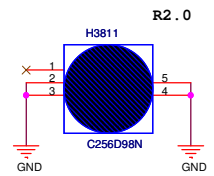
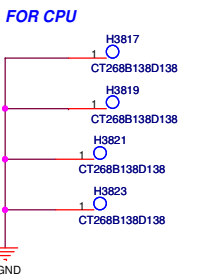
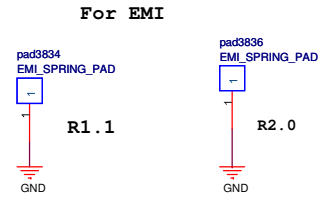
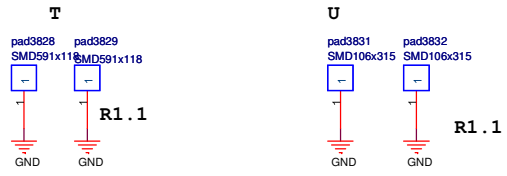
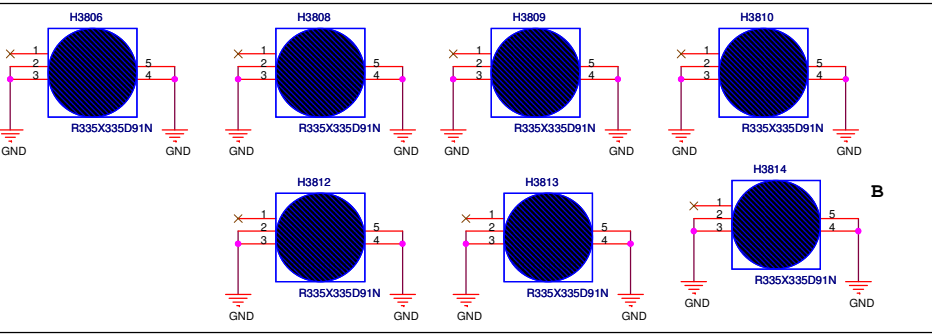
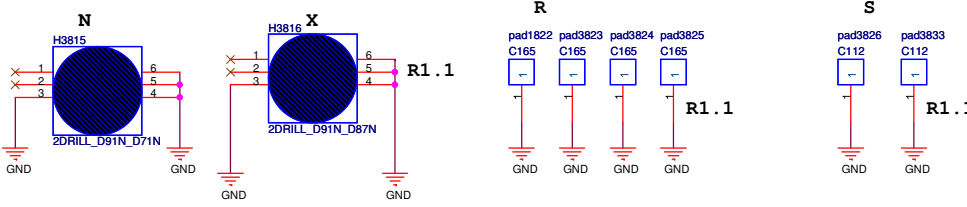
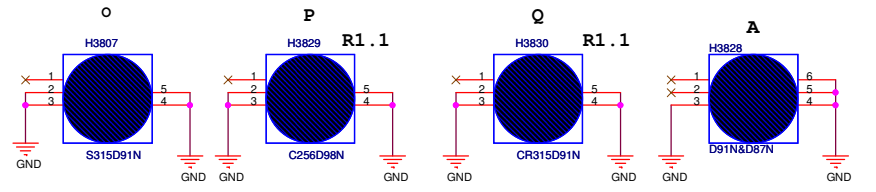
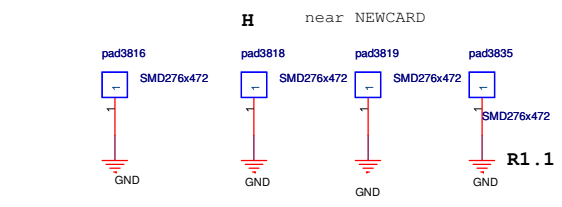
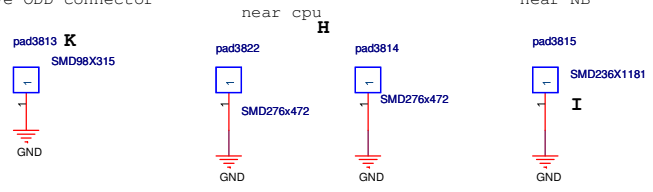
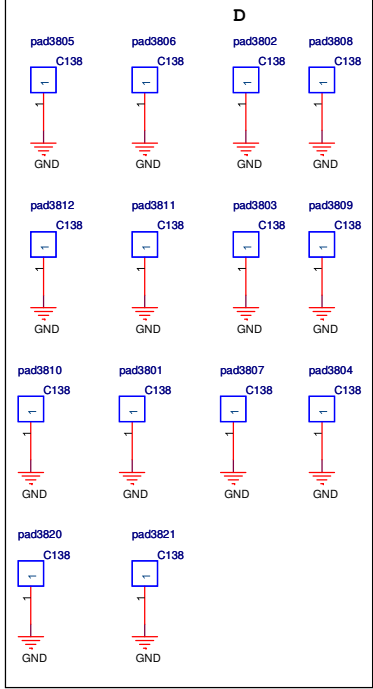

R2.0 change to P/N:13GN9980M090-1 for high limit

Dr-Bios.com

<Variant Name>		Title : Screw Hole	
ASUSTeK COMPUTER INC		Engineer: Chris_liu,Andy_Guo	
Size	Project Name	Rev	
Custom	F5R	2.0	
Date: 星期三, 十月 11, 2006	Sheet	38	of 71

Power SW.

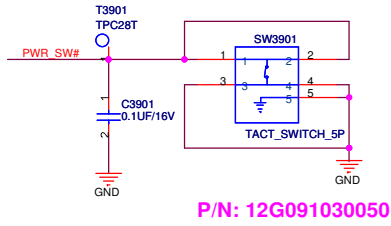

Marathon SW.

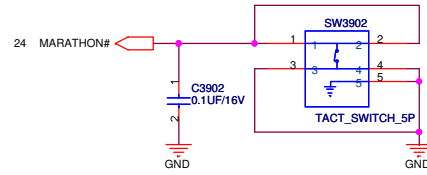

Disable Touch Pad SW.

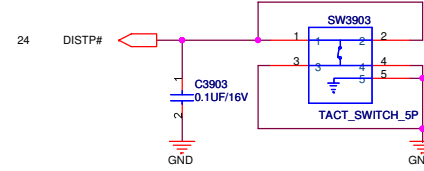

Internet SW.

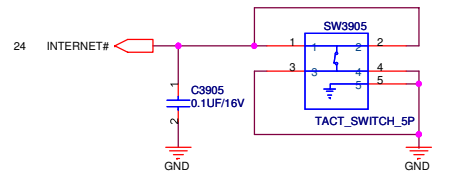

IstantON SW.

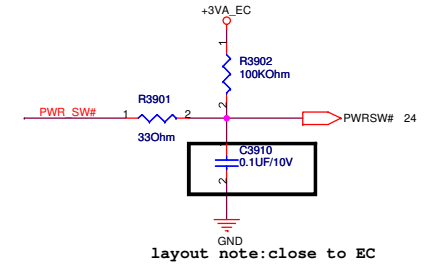
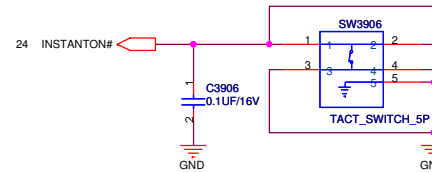

modify 05/17

Touch-Pad

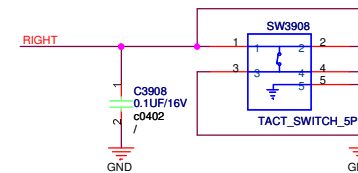
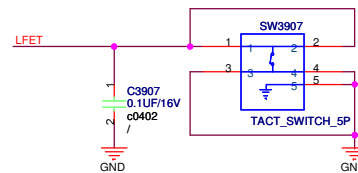
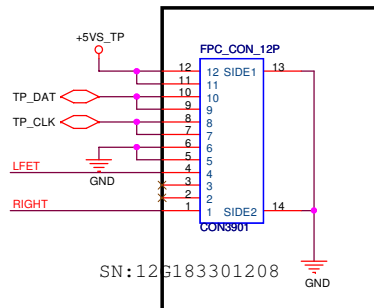
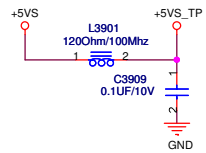

Dr-Bios.com

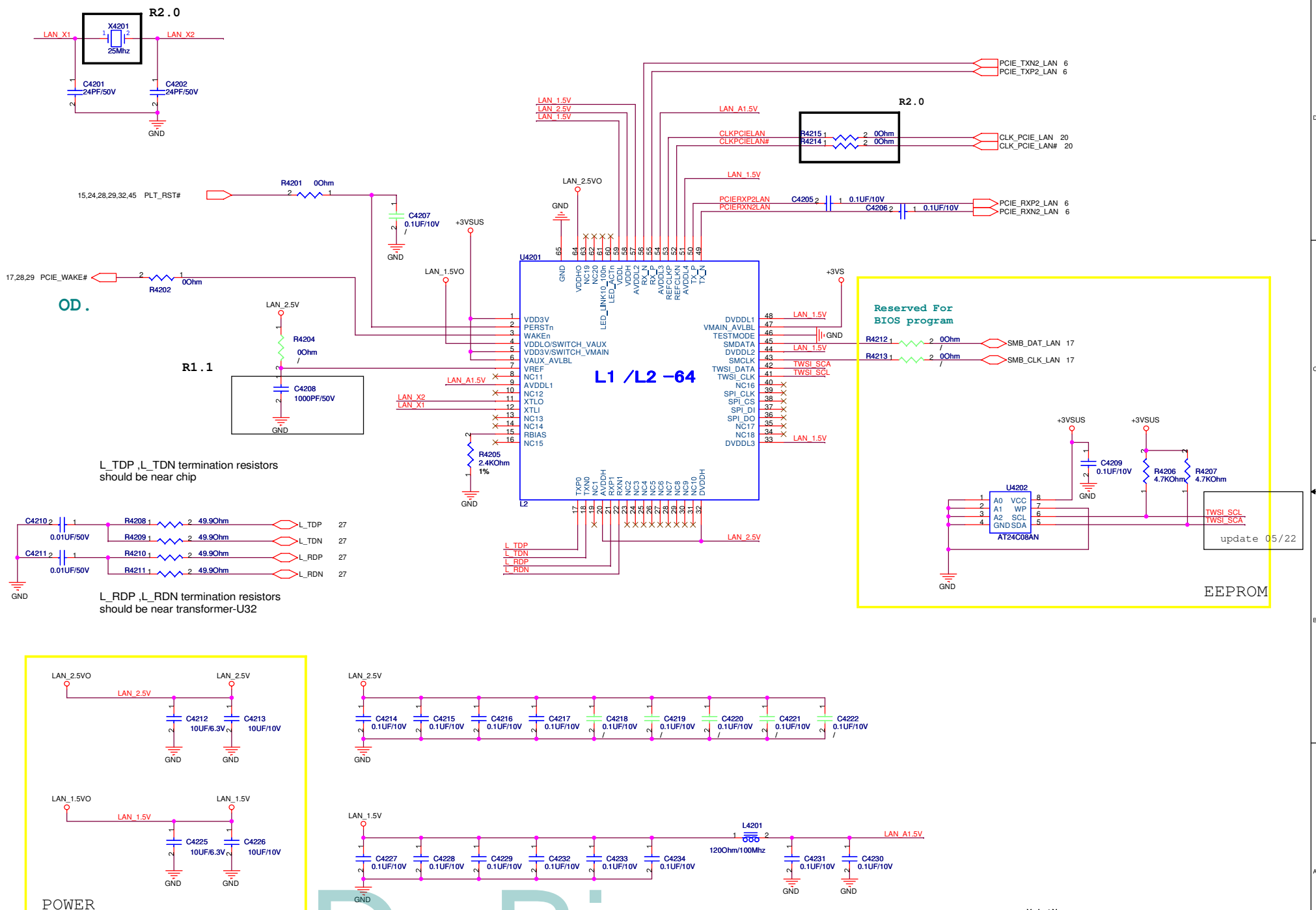

Dr-Bios.com

<Variant Name>

ASUS		Title : PCI-E LAN
ASUSTeK COMPUTER INC		Engineer: <i>Chris_luu,Andy_Guo</i>
Size Custom	Project Name F5R	Rev 2.0
Date: 星期三, 十月 11, 2006	Sheet 42	of 71

For TPM Module

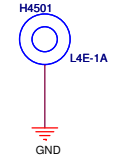
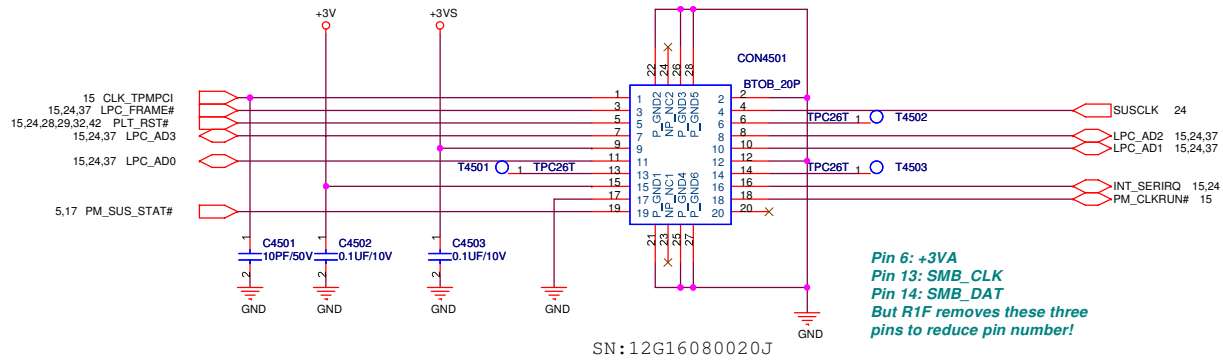

Dr-Bios.com

<Variant Name>		ASUS		Title : TPM	
ASUSTeK COMPUTER INC		Engineer: <i>Chris_liu,Andy_Guo</i>			
Size	Project Name			Rev	
Custom	F5R			2.0	
Date: 星期三, 十月 11, 2006	Sheet			45	of 71

change list:

06-05-12
 1. page16, add another thermal sensor schematic according to ATI demo schematic.
 2. page32. delete PATA HDD connector according to ME request
 3. page 12.13.17.add mem_sensor according to ATI demo schematic

06-05-15
 1.Add the ITP function on page 2,20,24.
 2. Page 24 delete the PWRLIMIT# net (power part has delete the power limit function)

06-05-16
 1.connect BATSEL_3S# to EC pin 40

05-06-17
 1.pag39 delete sw3904 according to markeeting spec
 2. page 22 add L2210 for layout request
 3.add L2303 for layout request

06-05-18
 1.page 32 update ODD connector CON3203 P/N
 2.PAGE 29 modify NEWCARD connector U2902 P/N

06-05-19
 1.page 32 update SATA connector CON3202 P/N

06-05-22
 1. page 5 change R510 to D501 according to F5X
 2. page5 ADD R513 according to F5X
 3. page 8 Remove L809,C811 according to ATI demo schematic
 4. page10 mount L1011,unmount L1015 due to using the D/A inverter
 5. page 15 remove R1524 due to SB600 (for Yonah)do not support H_PROCHOT
 6. page 16 mount R1604 according to ATI suggestion
 7. Page 17 add R1733,R1733 according to ATI suggestion
 8. Page 30mount U3001,C3009 according to F5X
 9. Page 38 add screw hole and pad
 10. Page 42 exchange TWSI_SCA and TWSI_SCL

06-05-23
 1. Page27 Add R2708 pull up resistor for Attansic request
 2. Page27 change C2702,C2703 to close to CON2702

06-05-24
 1. page12 modify CON1201 P/N

06-05-25
 1. Page38 add H3826 for lock fan
 2. delete some screw hole and add pad3820,pad3821

06-05-26
 1. page 38 add screw hole H3815 H3816

06-05-29
 1. page 17 exchange net USB_PP5 and USB_PP3,exchange net USB_PN5 and USB_PN3
 2. page 24 connect RF_ON_SW# to EC pin 25
 3. page16 connect net BT_ON# to SB600 GPIO47
 4. page 16connect net 802_LED_EN to GPIO55
 5. page 16 connect net BT_LED_EN to GPIO56

06-05-30
 1. page 22 connect con2202 pin 5,pin6 to GND_AUDIO

06-06-01
 1. Page 29 swap USB_PP6 and USB_PN6
 2. Page 30 swap USB_PP7 and USB_PN7
 3. Page 17 add pull up resistor R1735 and R1736,decoupling capacitor C1709 and C1710 on the USB_OC#01,USB_OC#23
 4. Page17 add test point T1725,T1726
 5. Page8 add test point T813

06-06-05
 1. page38 change H3807 P/N
 2. page22 delete net GND JACK
 3. page23 delete net GND JACK and JP2302

06-06-06
 Page 5 Add resistor R514 accordintg to Frank's suggestion
 Page 8 Add resistor R828 accordintg to Frank's suggestion
 Page 23 Add resistor R2311 for EMI request
 Page 23 change GND to GND_AUDIO for EMI request
 Page 3 Add C330 and C331 for EMI suggestion
 Page 65 connect PR6507 pin 2 to +12VS
 Page 24 delete Q2407 for repeat
 Page 29 Add R2905,unmout d2901 for cost down
 Page 21 change U2102 for cost down
 Page 20 change U2001 for thermal request

06-06-07
 Page 29 Modify the CON2901 schematic
 Page 14 delete RN1405,CN1405
 Page 16 connect VIN4 to R2902 for newcard shut down
 Page 17 connect USB_OC#8 to D2904,D2905 FOR NEW CARD DETECT
 Page 29 ADD R2902, D2904,D2905
 page 38 change pad3819 connect to GND for EMI request
 Page 29 swap USB_PP6 and USB_PN6

06-08
 page4 change CE401 P/N for hight limit

R1.1

Page3 DNI CE301,CE302,CE303,CE304,CE305
 Page4 R401,R406 change to 0 ohm
 Page5 R513 cahnge to 220K ohm,Mount R514, DNI R511
 Page8 add (L809 and C811)DNI for RC610
 Page16 X1601 change to PN:07G010Q02501 for cost
 Page22 R2201,R2203 change to 0ohm DNI R2205,R2206 chenge U2201 P/N for cost down
 page 24 R2404 change to 4.7Kohm
 Page27 R2708 change to 0 ohm,change CON2702 P/N
 Page28 Mount Q2803 for BIOS request
 Page30 R3011,R3012 change to 0 ohm according to attansic demo schematic
 Page32 C3201,C3202 change to 0.01u
 Page39 Reverse CON3901 pin definition for ME request
 Page42 X4201 change to PN:07G010Q02501 for cost down
 Page 2 change R227 pull-up resistor from 200 ohm resistor to 470 ohm resistor according ATI suggestion
 Page 5 remove D502 (for SB600,it is no need)
 Page 8 chang Q803 from N-MOS to P-MOS,add Q804 for correction
 Page11 correct HSYNC YSYNC the ESD protection diodes connect to +5VS instead of +3vs.
 page 15 add 8.2Kohm 5% pull-down resistor on A_RST# to ensure a logic low at initial power-on.
 Page 16 Please leave pin SATA_RX1/2/3+/- unconnected, do not connected them to ground according to ATI suggestion
 Page 16 remove R1609,RN1601according to ATI suggestion
 Page 17 change R1730,R1731,R1732 pull-up resistor to +3.3VSUS
 page 38 add EMI finger
 page 16 change C1611,C1612 from 24pf to 10pf

R2.0

page 2 ,24 add CPU throttle function for power team request (add Q2407)
 page16 delete change net name CPPE_EN,and delete its pull down resistor RN1604
 page17 change net name CPPE_DET#, unmount R1730,R1731,R1732 for fix bug :cannot find ODD
 page 22 exchange SPKL+ SPKL-,SPKR+ SPKR-,EAR_R EAR_L for correction, add R2219 for vista option
 Modify CON3001,CON2801,CON2703,H3801,H3802 P/N
 Modify R2102 value from 33ohm to 47ohm for correcting AC_SDINO slew rate.
 Modify L1101,L1102,L1103 from bead to inductor 68nH for correction R G B signal rise time falling time and amplitude



ASUS		Title : change list	
ASUSTeK COMPUTER INC		Engineer: Chris_liu,Andy_Guo	
Size	Project Name	Rev	
Custom	F5R	2.0	
Date: 2006年10月11日		Sheet	46 of 71

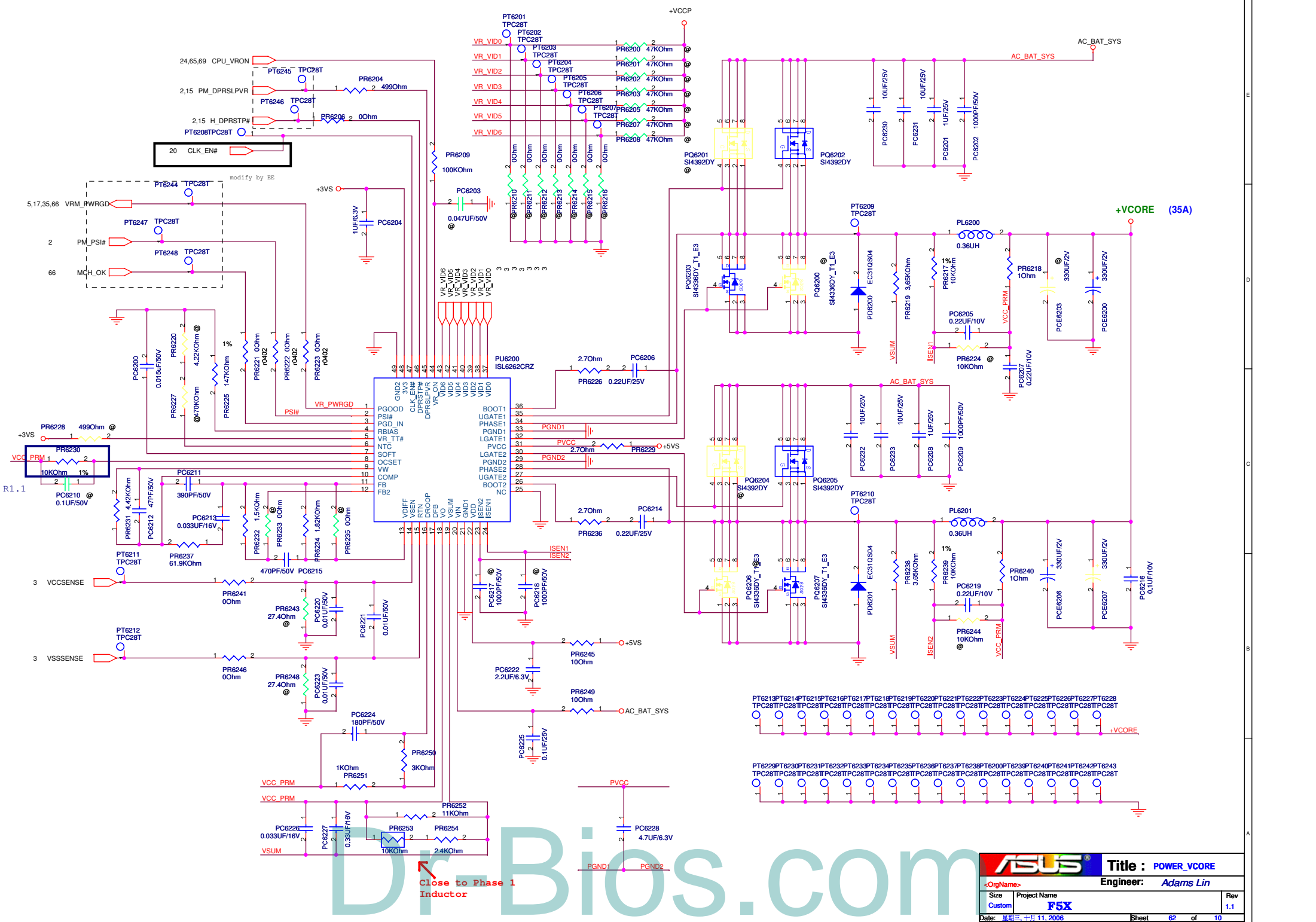

Close to Phase 1 Inductor

		Title : POWER_VCORE	
		Engineer: Adams Lin	
Size Custom	Project Name F5X	Rev 1.1	
Date: 2006年11月11日	Sheet: 62	of 10	

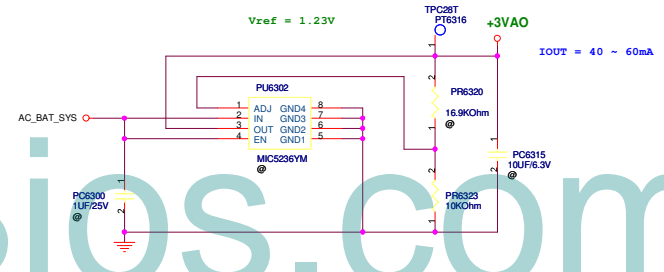
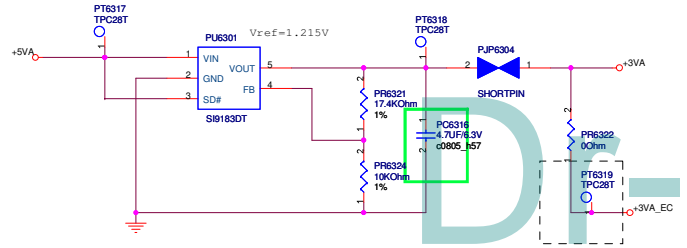
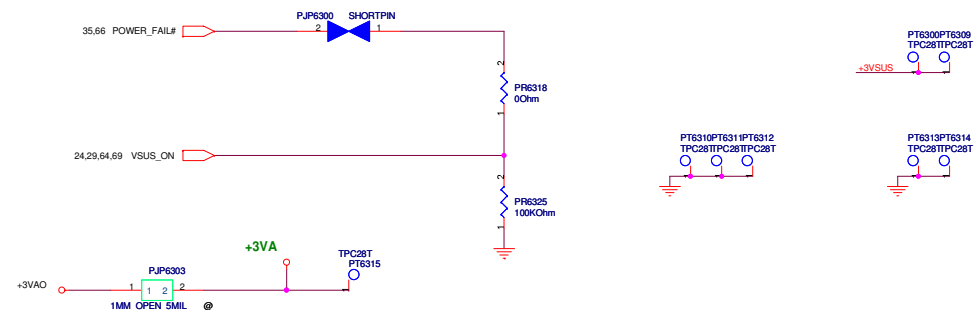
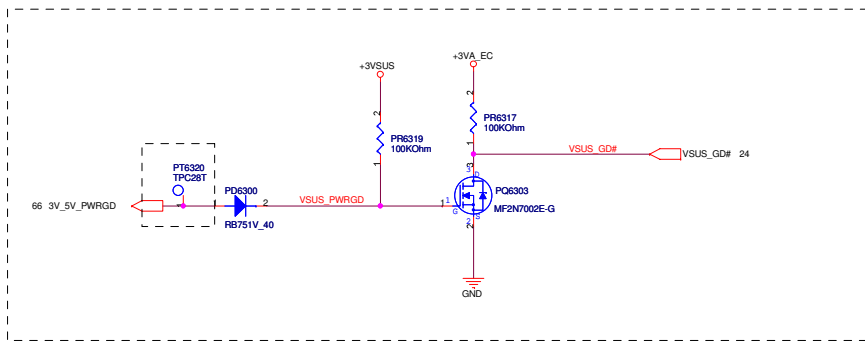
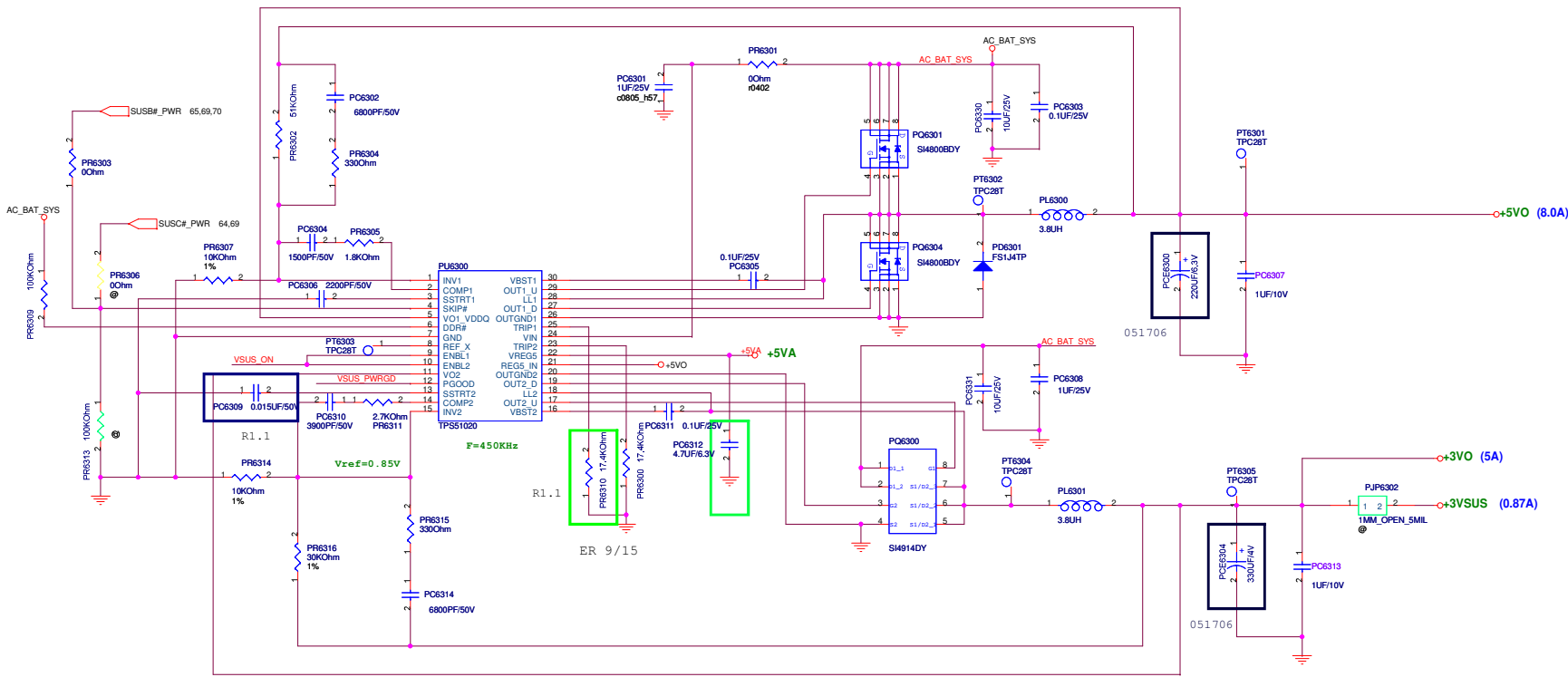

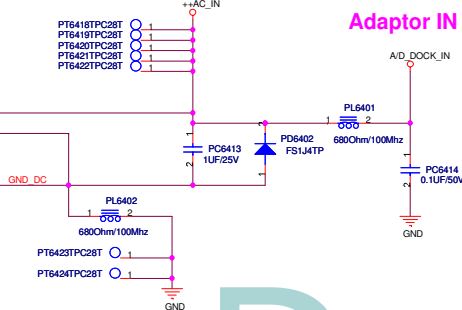
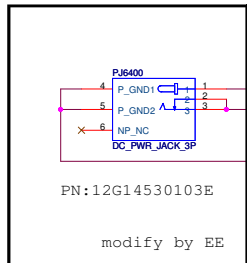
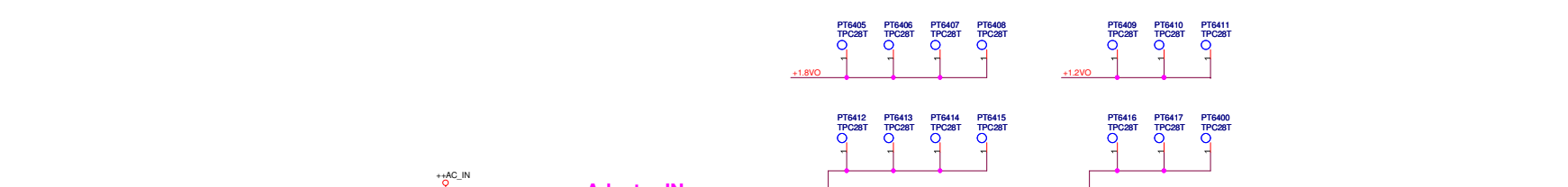
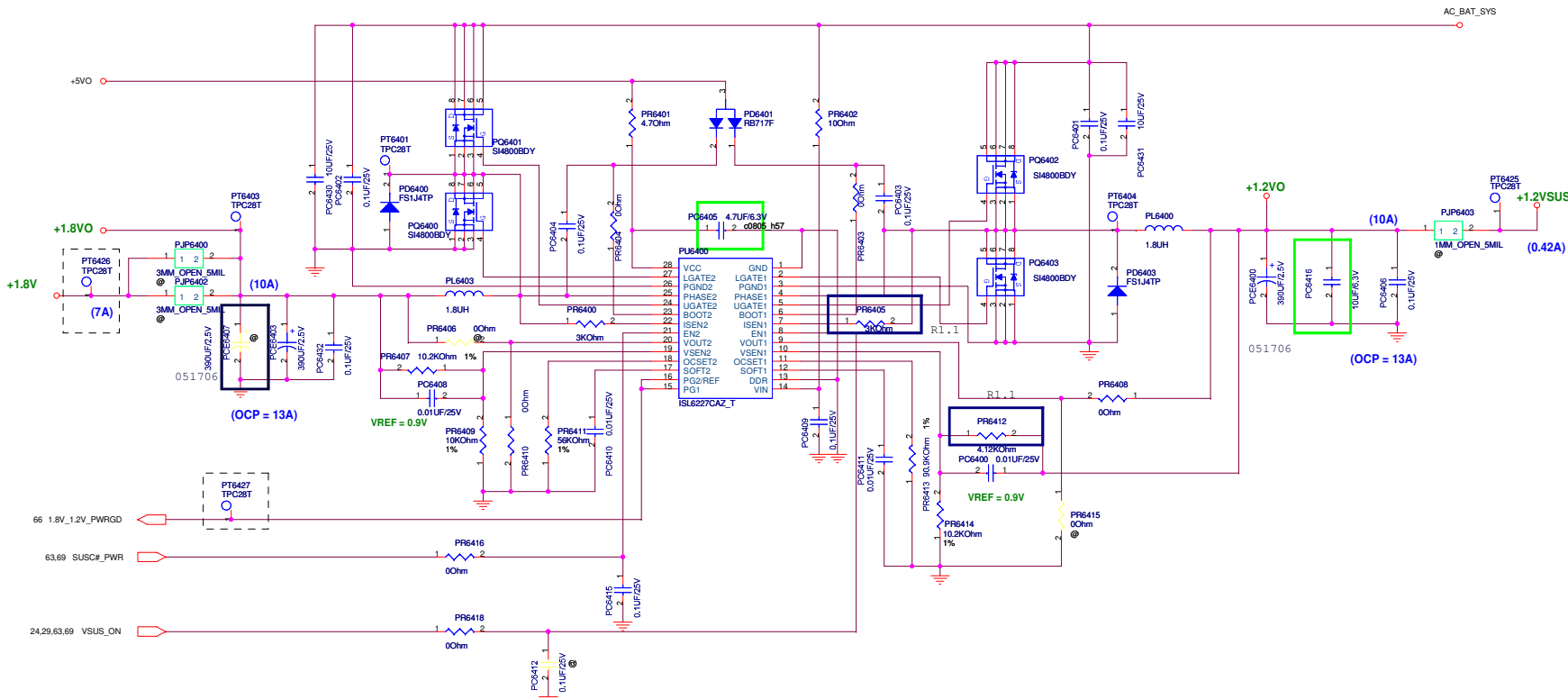

Dr-Bios.com

ASUS		Title : 1.8V&1.2VS
<OrgName>		Engineer: Adams Lin
Size	Project Name	Rev
C	FSX	1.1
Date: 2006-11-11	Sheet	64 of 10

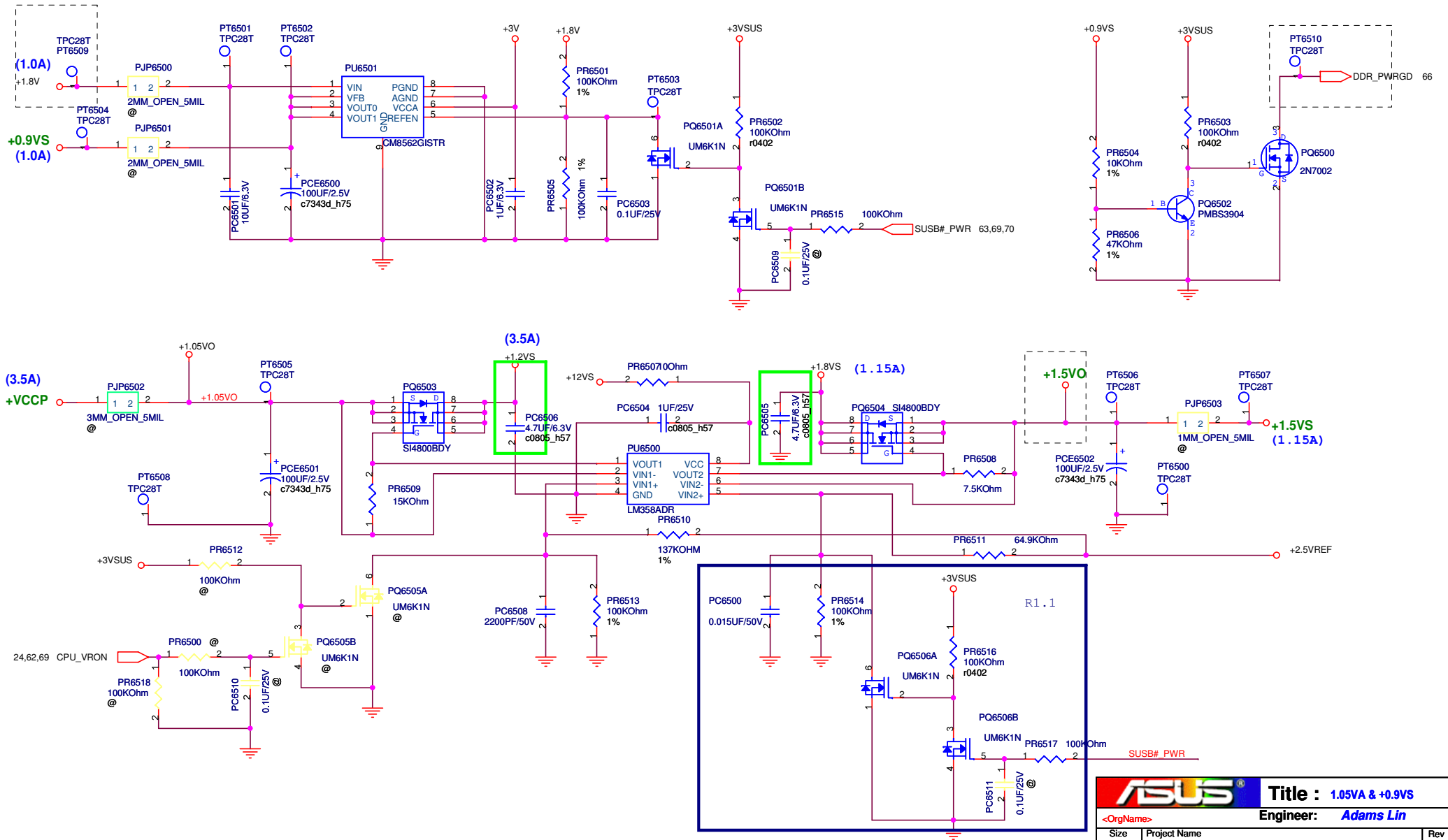

ASUS		Title : 1.05VA & +0.9VS	
<OrgName>		Engineer: Adams Lin	
Size	Project Name	Rev	
B	FSX	1.1	
Date: 星期三, 十月 11, 2006		Sheet 65 of 10	

Dr-Bios.com

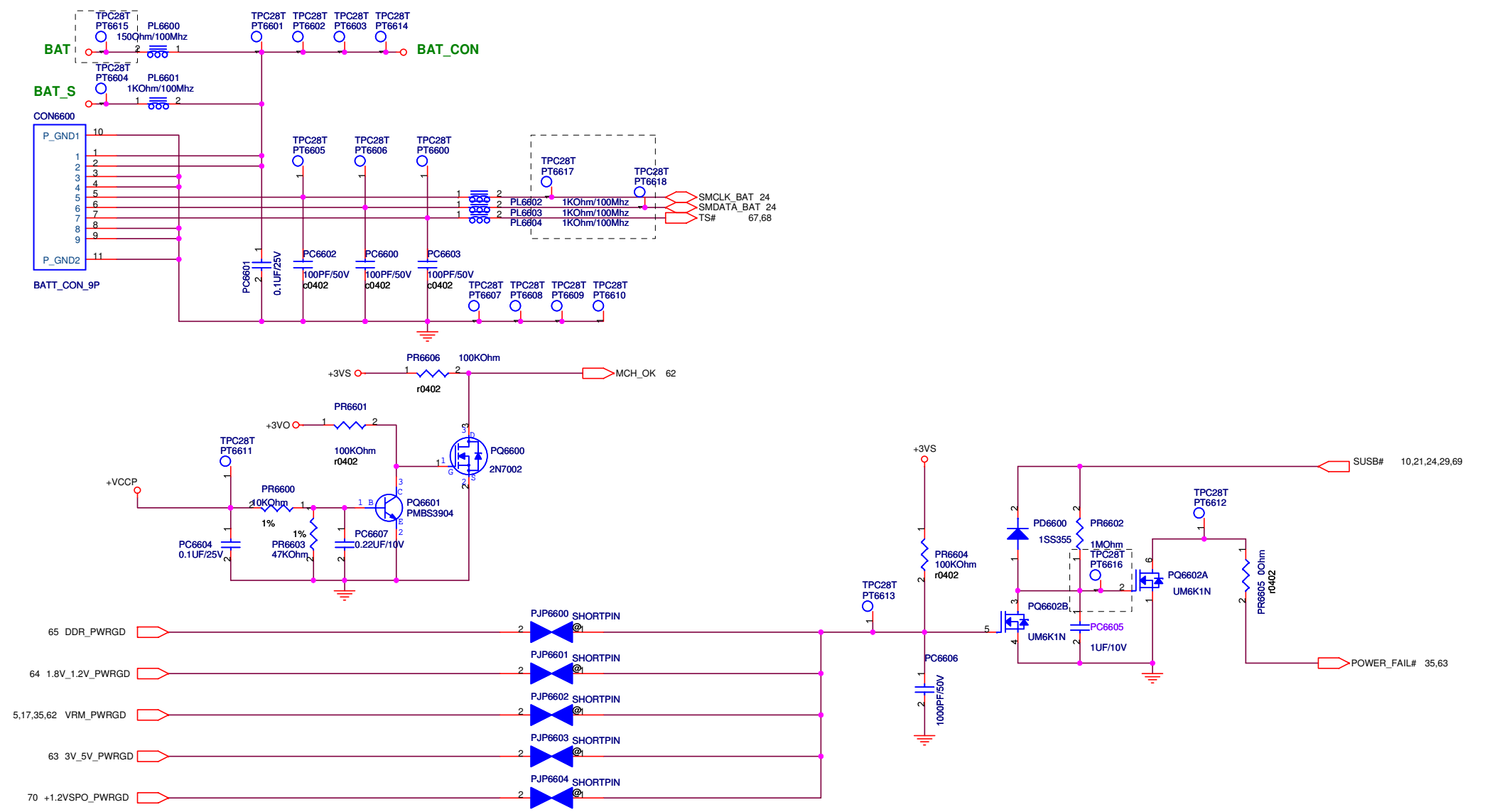

ASUS		Title : BAT CON/PWOK	
<OrgName>		Engineer: Adams Lin	
Size	Project Name	Rev	
B	F5X	1.1	
Date: 星期三, 十月 11, 2006	Sheet 66	of 10	

Dr-Bios.com

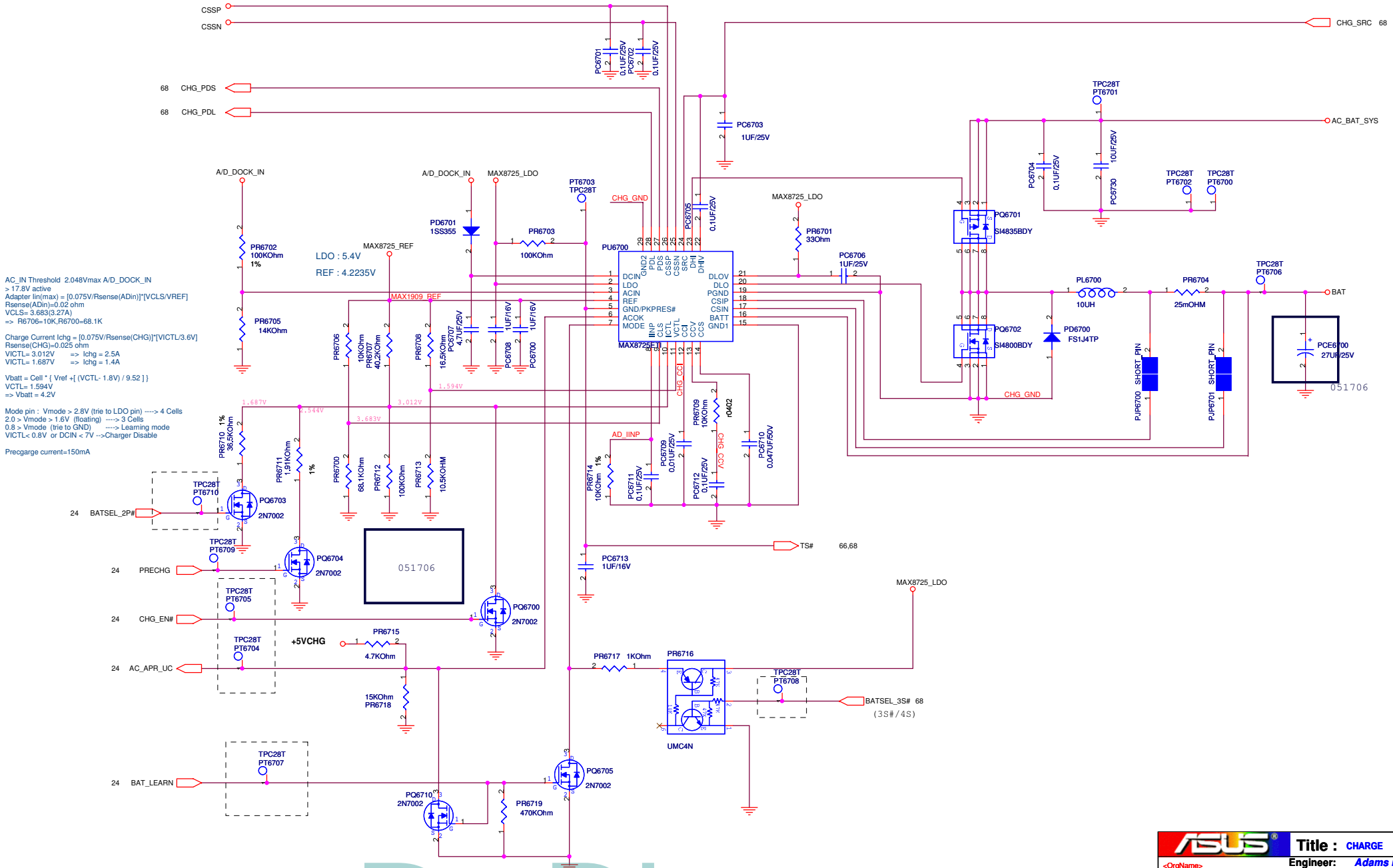

AC_IN Threshold 2.048Vmax A/D_DOCK_IN
 > 17.8V active
 Adapter lin(max) = [0.075V/Rsense(ADin)]*[VCLS/VREF]
 Rsense(ADin)=0.02 ohm
 VCLS= 3.683(3.27A)
 => R6706=10K,R6700=68.1K

Charge Current Ichg = [0.075V/Rsense(CHG)]*[VICTL/3.6V]
 Rsense(CHG)=0.025 ohm
 VICTL= 3.012V => Ichg = 2.5A
 VICTL= 1.687V => Ichg = 1.4A

Vbatt = Cell * [Vref + (VCTL - 1.8V) / 9.52]
 VCTL = 1.594V
 => Vbatt = 4.2V

Mode pin : Vmode > 2.8V (try to LDO pin) ----> 4 Cells
 2.0 > Vmode > 1.6V (flucting) ----> 3 Cells
 0.8 > Vmode (try to GND) ----> Learning mode
 VICTL < 0.8V or DCIN < 7V ----> Charger Disable

Preccharge current=150mA

ASUS		Title : CHARGE	
<OrgName>		Engineer: Adams Lin	
Size	Project Name	Rev	
Custom	FSX	1.1	
Date: 星期三, 十月 11, 2006		Sheet	67 of 10

Dr-Bios.com

BATTERY IN DETECT

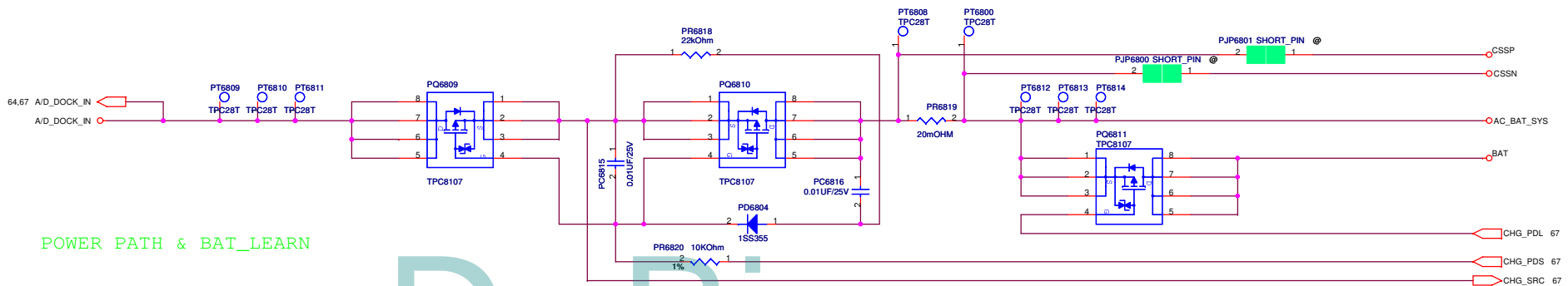
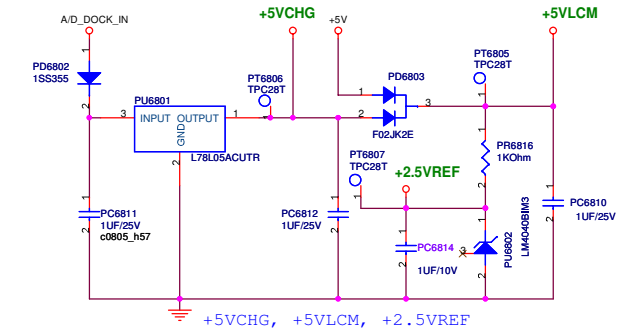
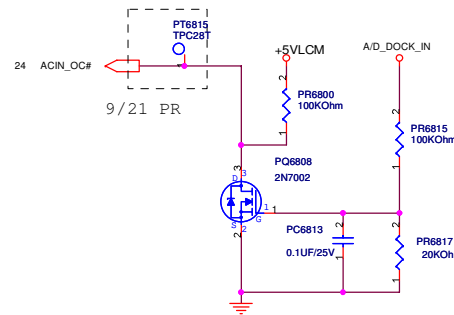
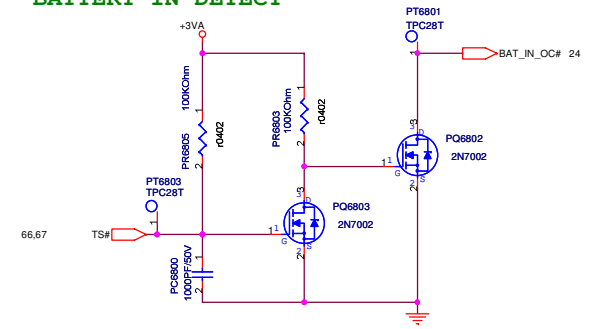

POWER PATH & BAT_LEARN

Dr-Bios.com

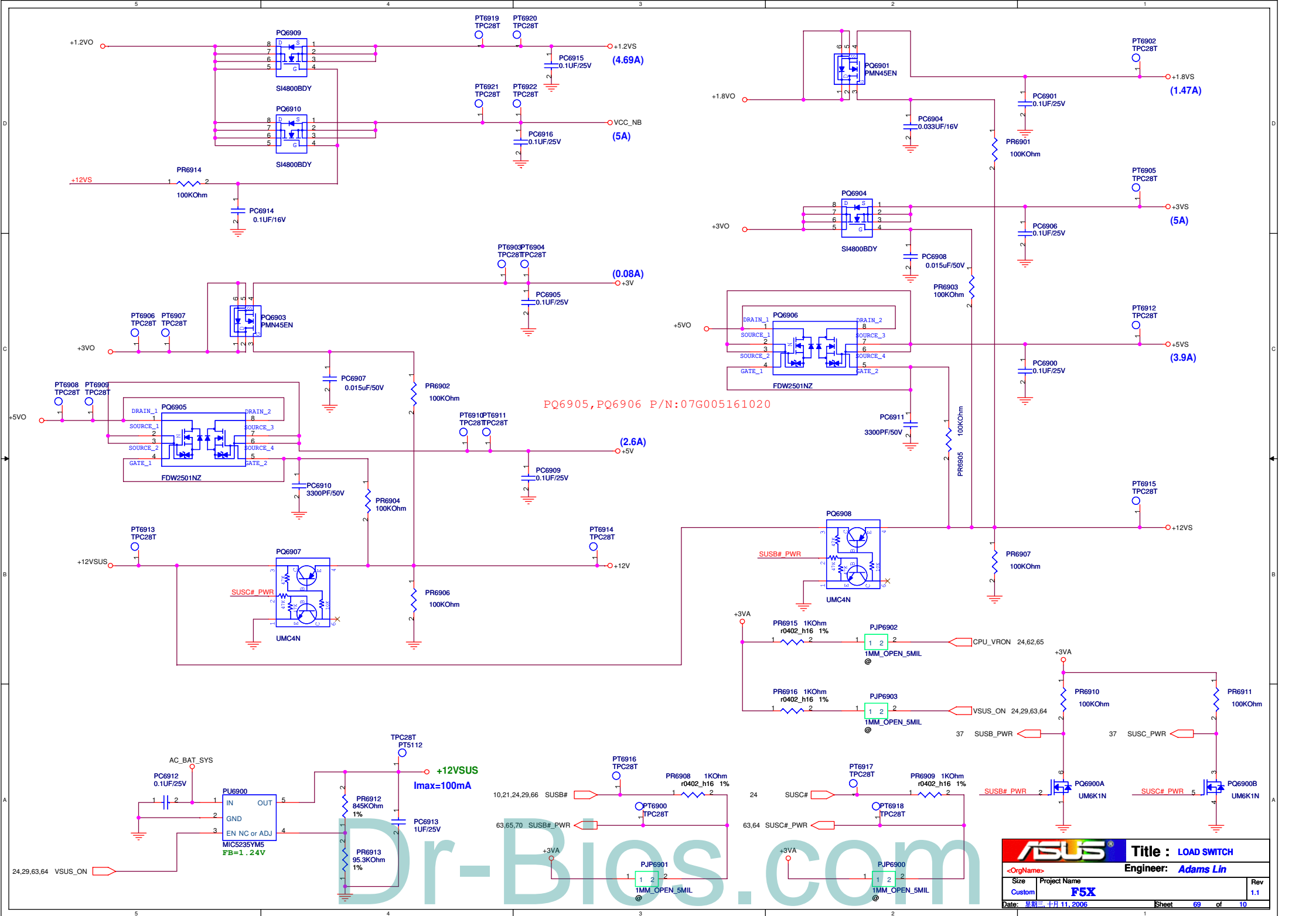

PQ6905, PQ6906 P/N: 07G005161020

ASUS		Title : LOAD SWITCH	
<OrgName>		Engineer: Adams Lin	
Size	Project Name	Rev	
Custom	FSX	1.1	
Date: 星期二, 十月 11, 2006		Sheet 69 of 10	

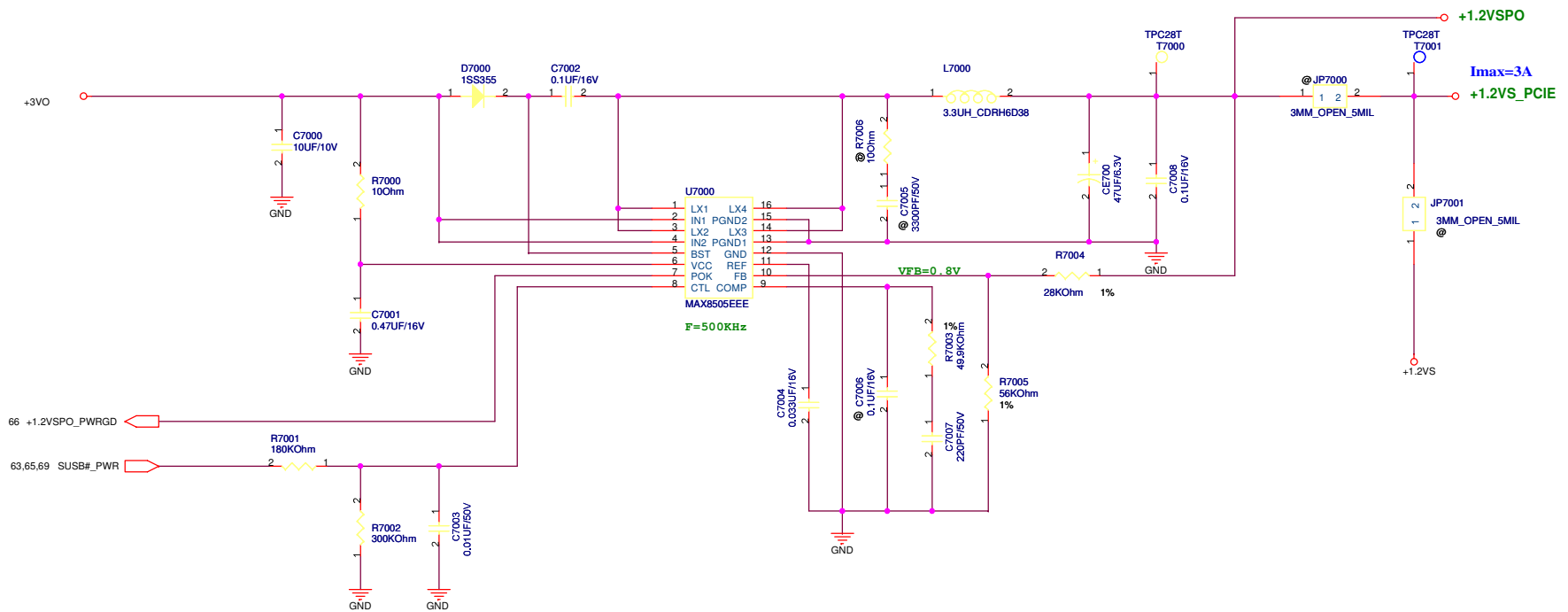

Dr-Bios.com

ASUS		Title : POWER_1.2VS_PCIE	
-<OrigName>		Engineer:	
Size	Project Name		Rev
Custom	F5X		1.1
Date: 星期二, 十月 11, 2006		Sheet	70 of 10

