

TABLE OF CONTENTS

PAGE	PAGE
1.COVER PAGE	32.RTC
2.INDEX	33.CARDBUS CONTROLLER
3.BLOCK DIAGRAM	34.PCMCIA & EXPRESS CARD
4.POWER SEQUENCE BLOCK	35.5 IN 1 MEMORY CARD
5-11.SYSTEM POWER	36.1394 CONTROLLER
12.CLOCK GENERATOR	37.MINIPCI CONN
13.CPU(1/4)	38.LAN CONTROLLER
14.CPU(2/4)	39.RJ45 & TRANSFORMER
15.CPU(3/4)	40.HDD CONN
16.CPU(4/4)	41.ODD CONN
17.FAN&THERMAL CONTROLLER	42.USB CONN
18.N/B(1/5)	43.SUPER I/O
19.N/B(2/5)	44.K/B & D/B CONN
20.N/B(3/5)	45.AC97 CODEC
21.N/B(4/5)	46.AUDIO AMP
22.N/B(5/5)	47.MDC
23.DDR2 DIMM0	48.SWITCH & LED (MB)
24.DDR2 DIMM1	49.SWITCH & LED (DB)
25.DDR2 DAMPING	50.USB & SVIDEO BOARD
26.CRT	51.TP BOARD
27.LCM	
28.S-VIDEO	
29.S/B(1/5)	
30.S/B(2/5)	
31.S/B(3/5)	

INVENTEC

TITLE *SA10EJV*

SIZE A3	CODE CS	DOC. NUMBER <i>1310A2076701</i>	REV A02
SHEET		2	OF 51

CHANGE by *Kobby Wen* *21-Feb-2006*

8

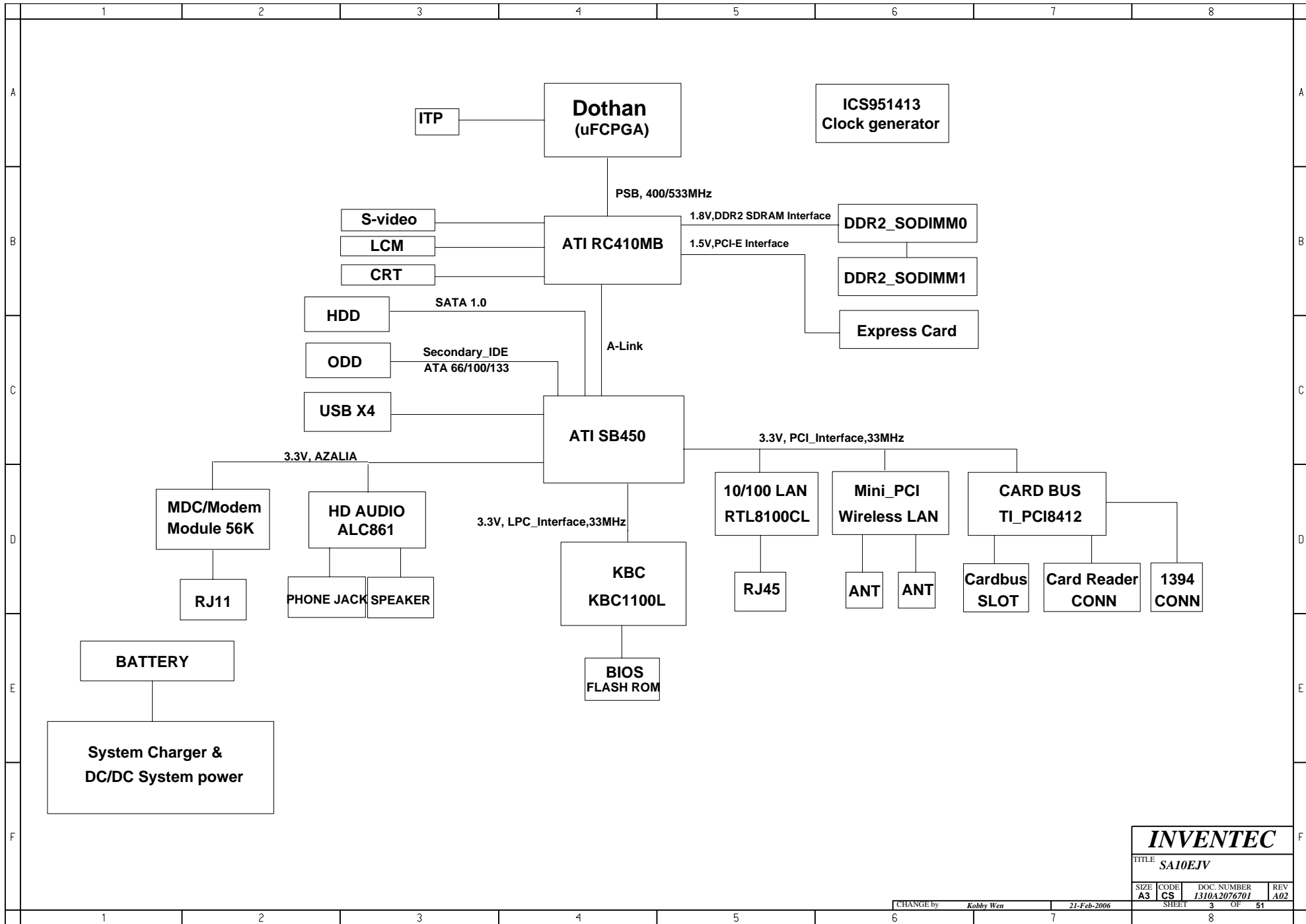

INVENTEC

TITLE SA10EJV

SIZE A3	CODE CS	DOC. NUMBER 1310A2076701	REV A02
------------	------------	-----------------------------	------------

CHANGE by Kobby Wen 21-Feb-2006 SHEET 3 OF 51

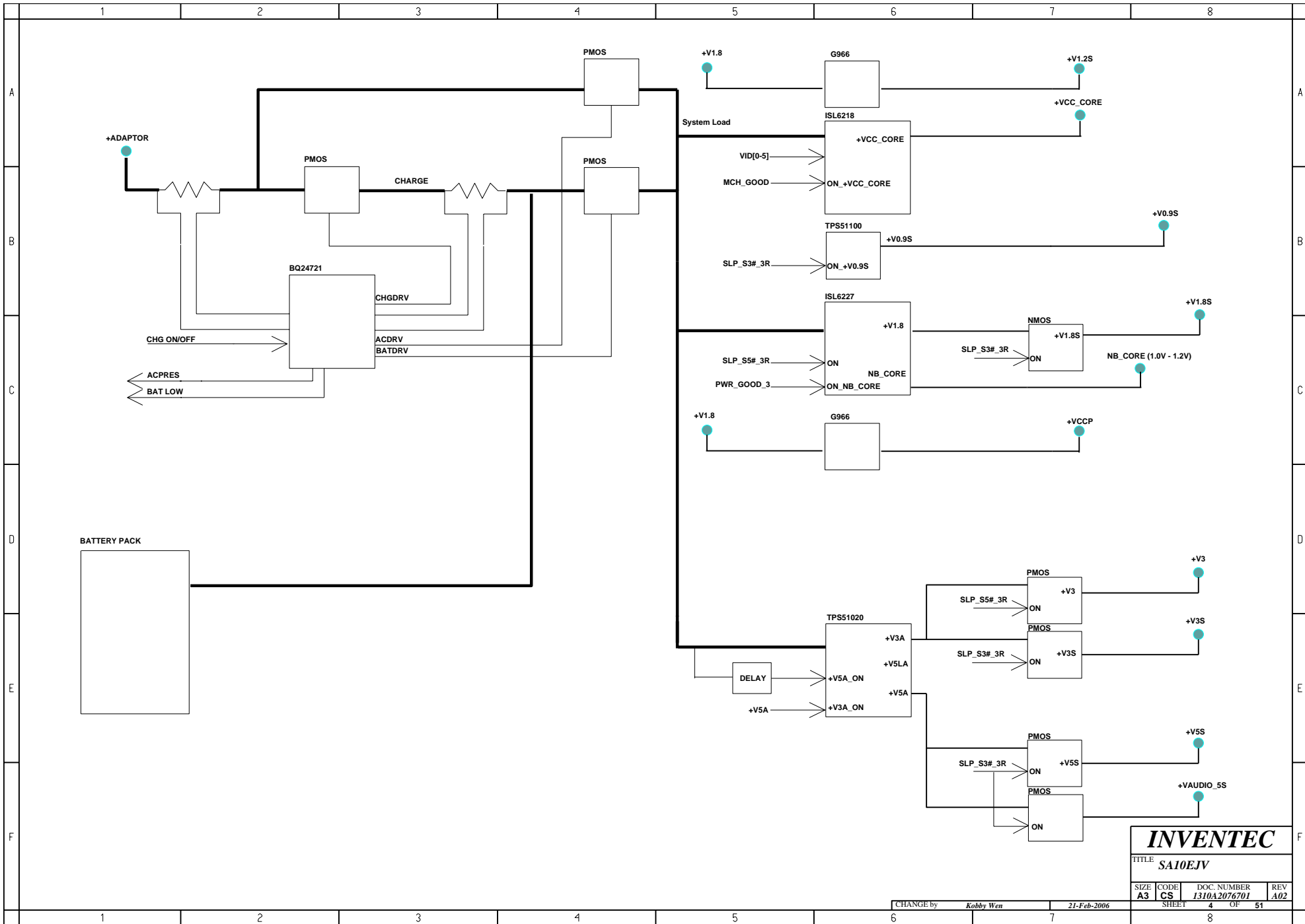

INVENTEC			
TITLE SA10EJV			
SIZE A3	CODE CS	DOC. NUMBER 1310A2076701	REV A02
CHANGE by Kobby Wen		21-Feb-2006	
SHEET 4		OF 51	

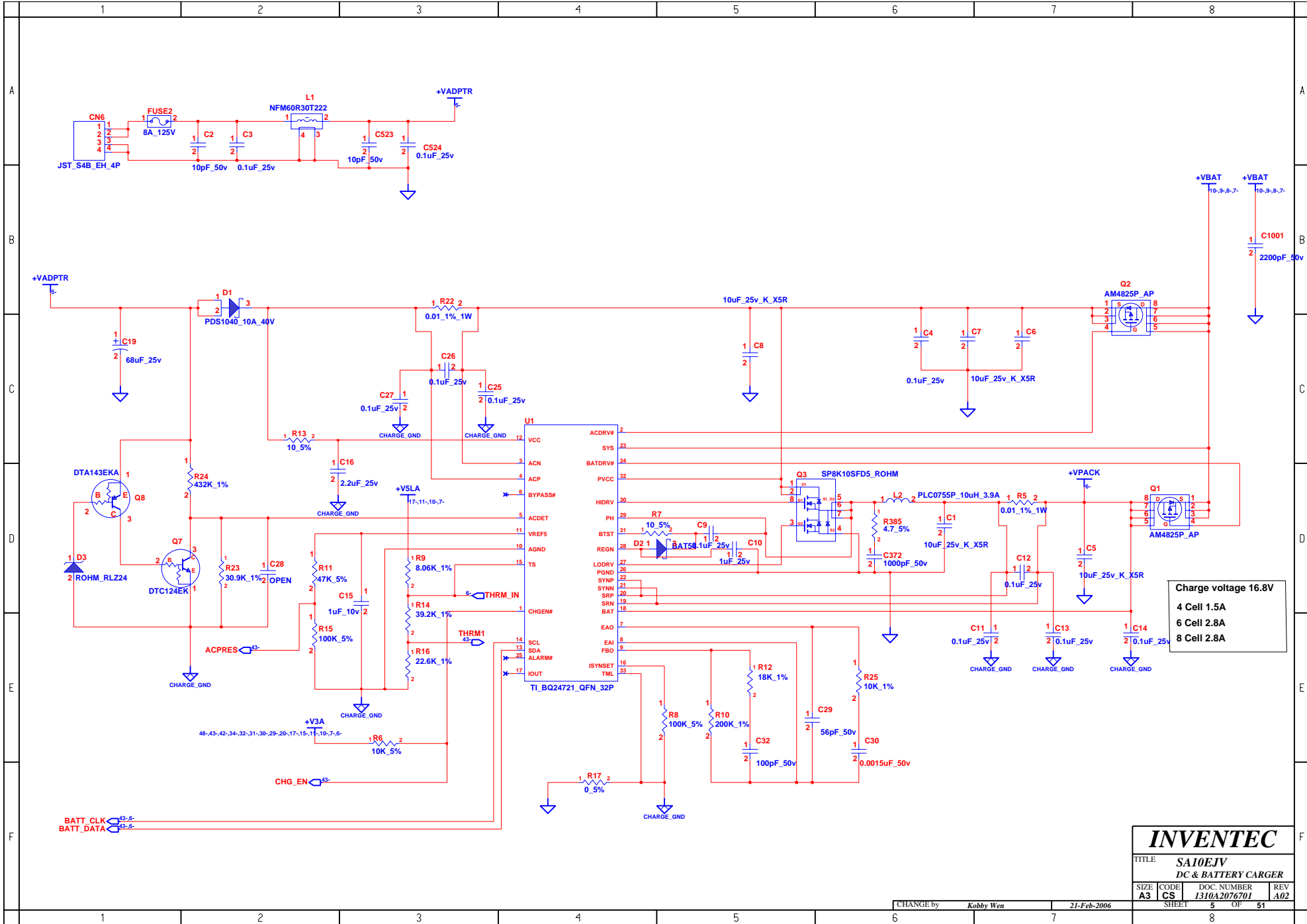

Charge voltage 16.8V
 4 Cell 1.5A
 6 Cell 2.8A
 8 Cell 2.8A

INVENTEC			
TITLE SAI0EJV			
DC & BATTERY CHARGER			
SIZE	CODE	DOC. NUMBER	REV
A3	CS	1310A2076701	A02
CHANGE by <i>Kobby Wen</i>		21-Feb-2006	
SHEET 5		OF 51	

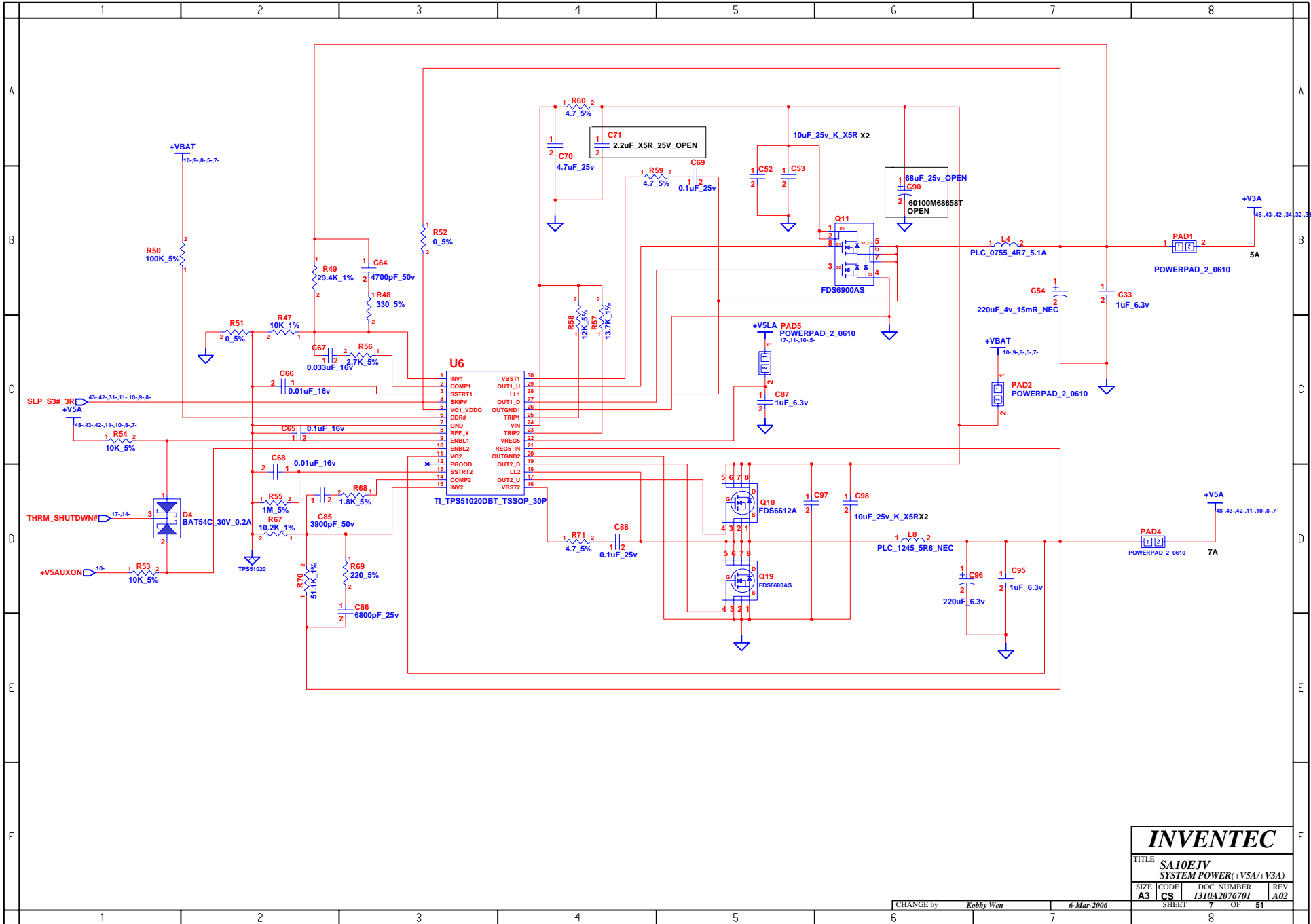

INVENTEC

TITLE SA10EJV
SYSTEM POWER(+V5A/+V3A)
SIZE A3 CODE CS DOC NUMBER 1310A2076701 REV A02

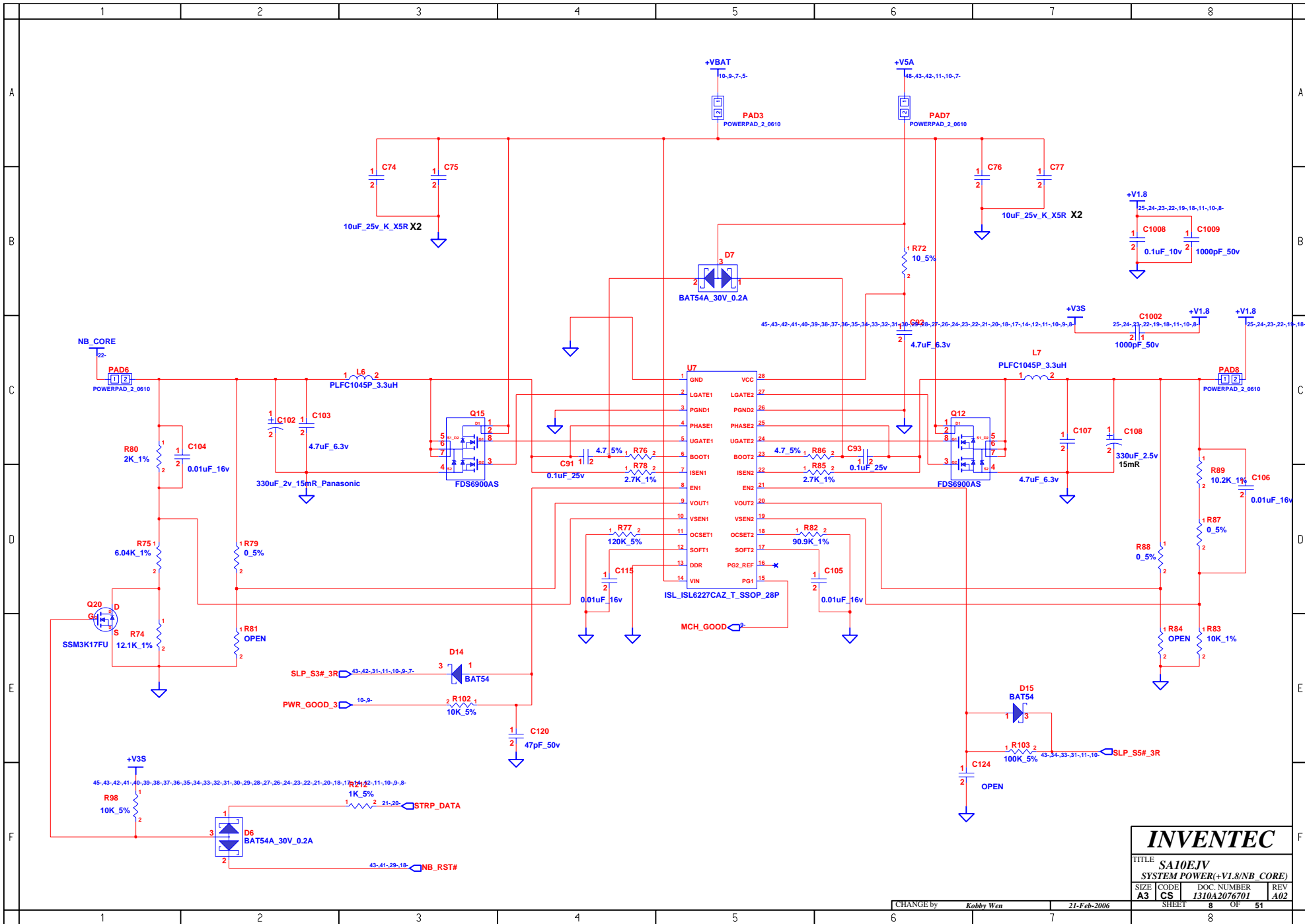

INVENTEC			
TITLE SAI0EJV			
SYSTEM POWER(+V1.8/NB_CORE)			
SIZE A3	CODE CS	DOC. NUMBER 1310A2076701	REV A02
CHANGE by Kobby Wen		21-Feb-2006	
SHEET 8		OF 51	

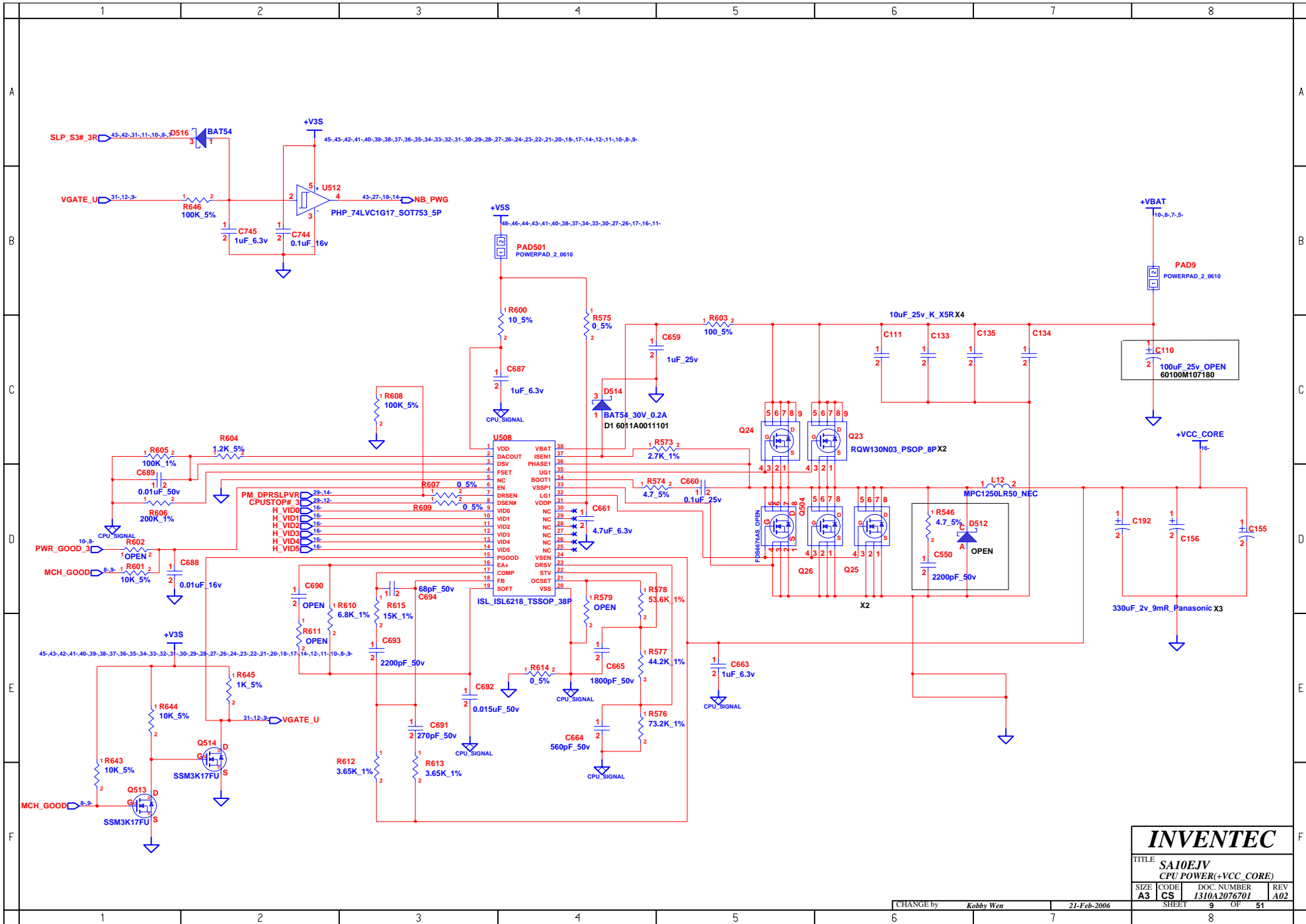

INVENTEC			
TITLE SA10EJV CPU POWER(+VCC_CORE)			
SIZE A3	CODE CS	DOC. NUMBER I310A2076701	REV A02
CHANGE by Kobby Wen		21-Feb-2006	
SHEET 9		OF 51	

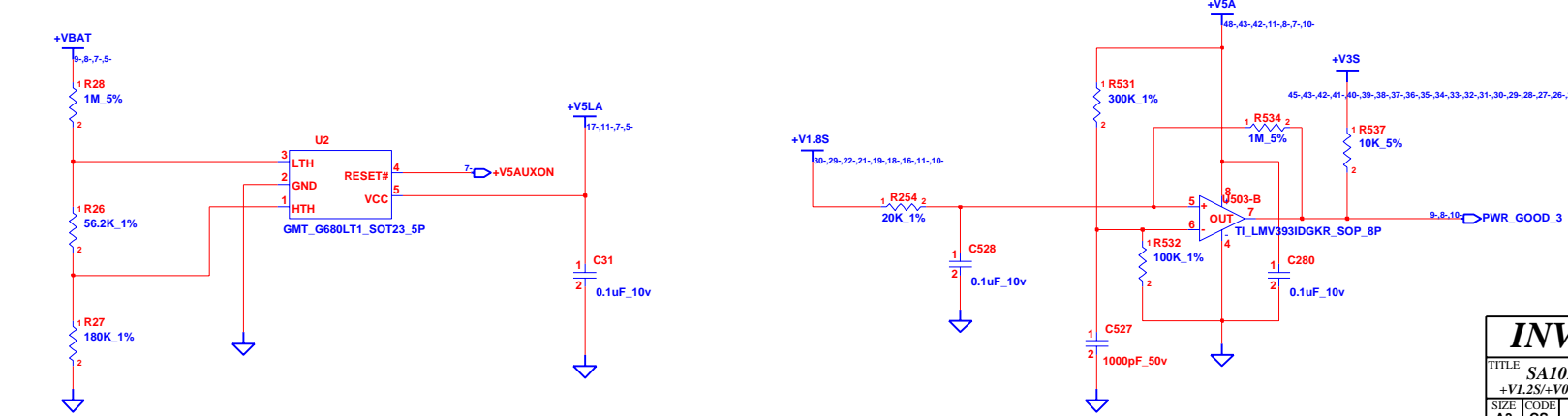
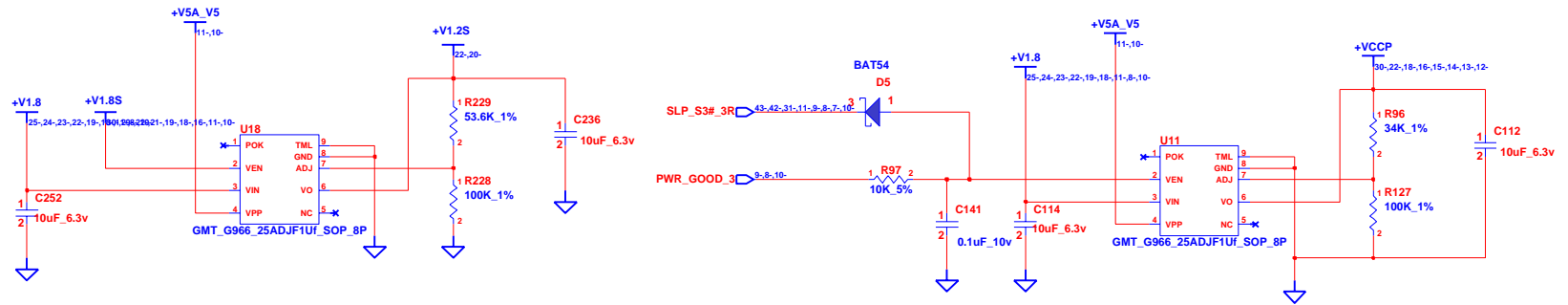
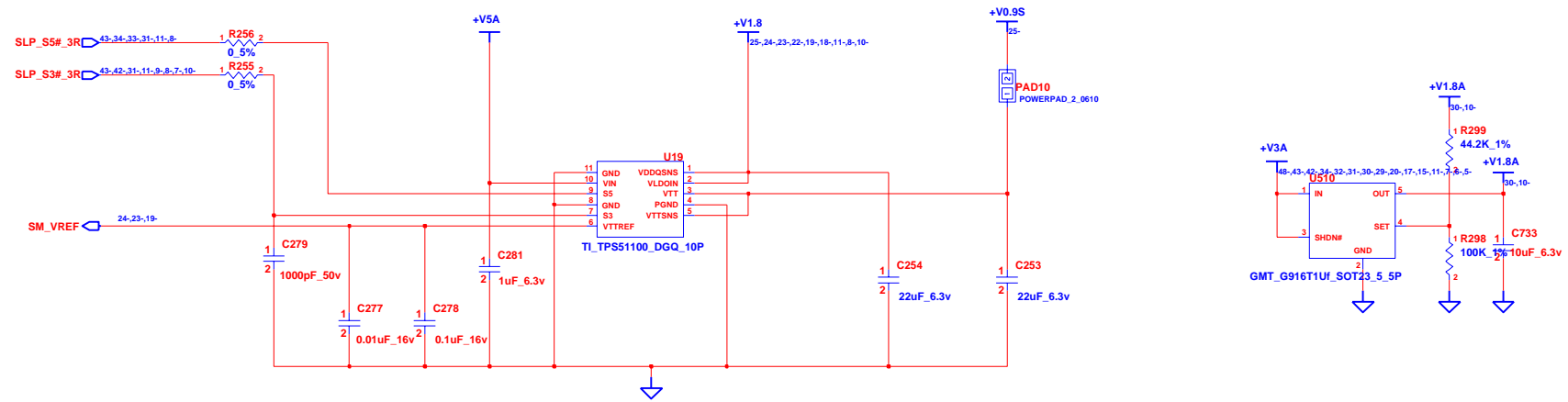

INVENTEC			
TITLE SA10EJV			
+V1.2S/+V0.9S/+VCCP/PWR_GOOD			
SIZE A3	CODE CS	DOC. NUMBER 1310A2076701	REV A02
CHANGE by <i>Kobby Wen</i>		21-Feb-2006	
SHEET 10		OF 51	

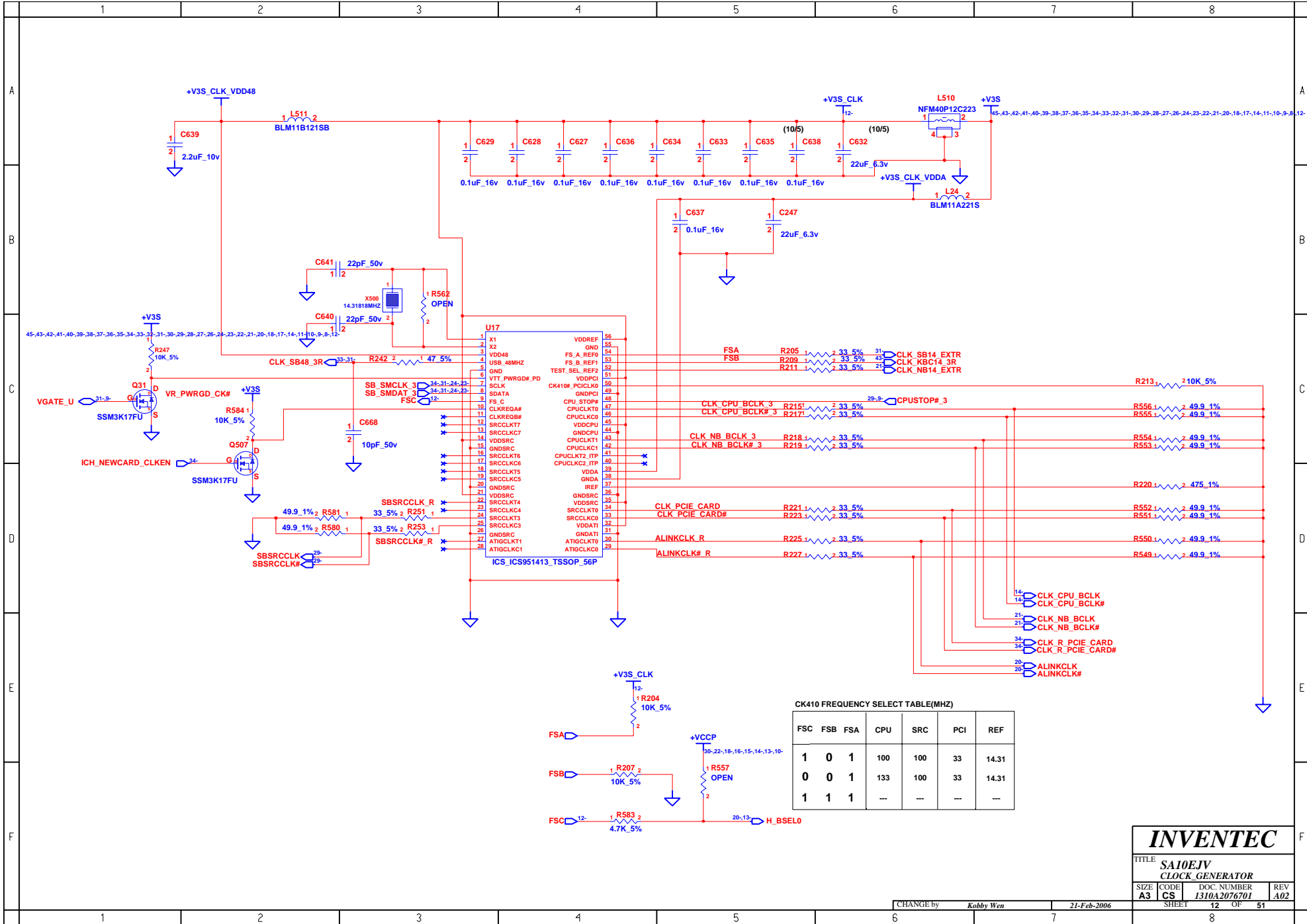

CK410 FREQUENCY SELECT TABLE(MHZ)

FSC	FSB	FSA	CPU	SRC	PCI	REF
1	0	1	100	100	33	14.31
0	0	1	133	100	33	14.31
1	1	1	---	---	---	---

INVENTEC

TITLE
SA10EJV
CLOCK GENERATOR

SIZE CODE DOC NUMBER REV
A3 CS 1310A2076701 A02

CHANGE by Kobby Wen 21-Feb-2006

SHEET 12 OF 51

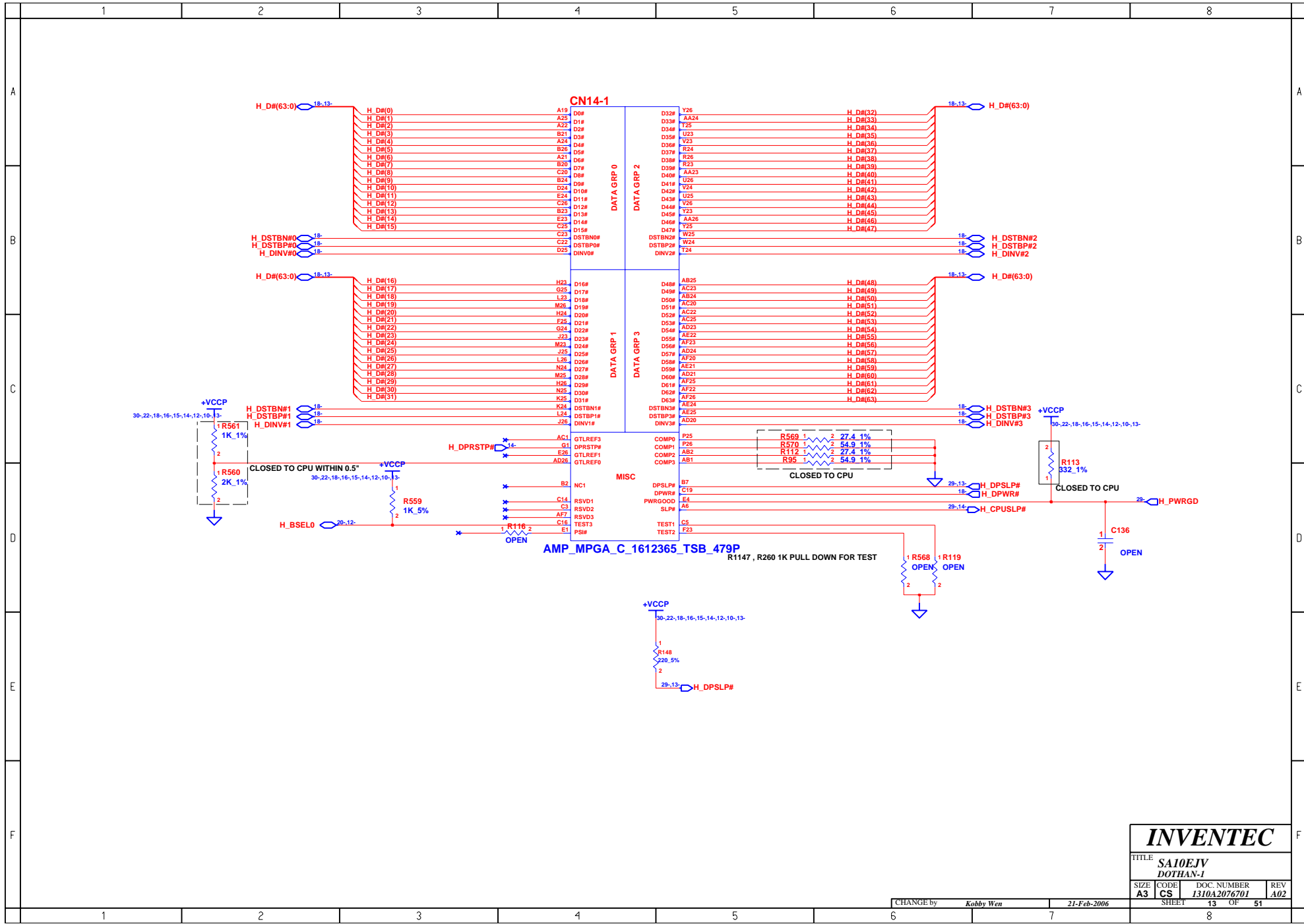

INVENTEC			
TITLE SA10EJV DOHAN-1			
SIZE A3	CODE CS	DOC. NUMBER 1310A2076701	REV A02
CHANGE by <i>Kobby Wen</i>		21-Feb-2006	
SHEET 13		OF 51	

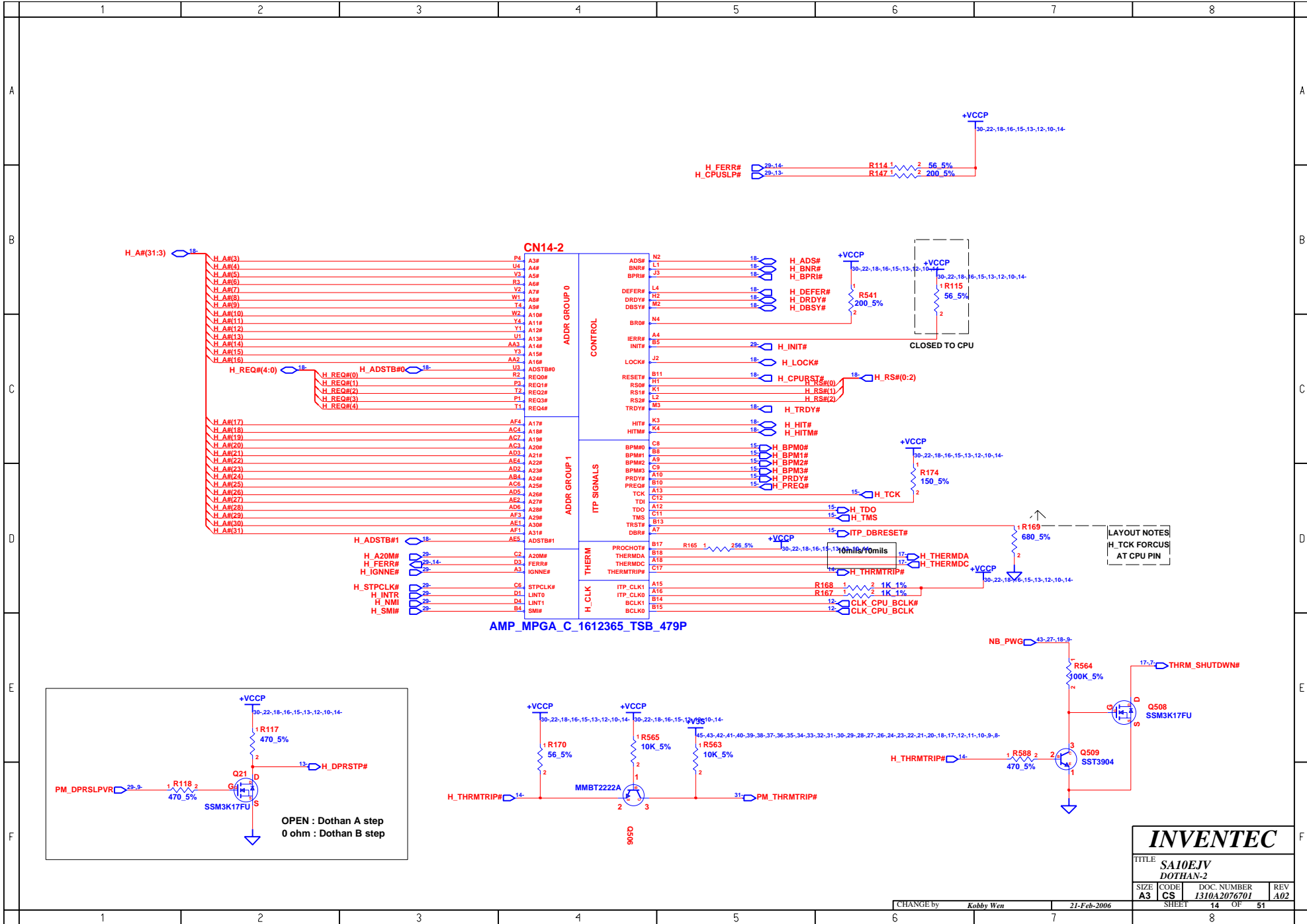

INVENTEC			
TITLE SA10EJV DOTHAN-2			
SIZE A3	CODE CS	DOC. NUMBER 1310A2076701	REV A02
CHANGE by Kobby Wen		21-Feb-2006	
SHEET 14		OF 51	

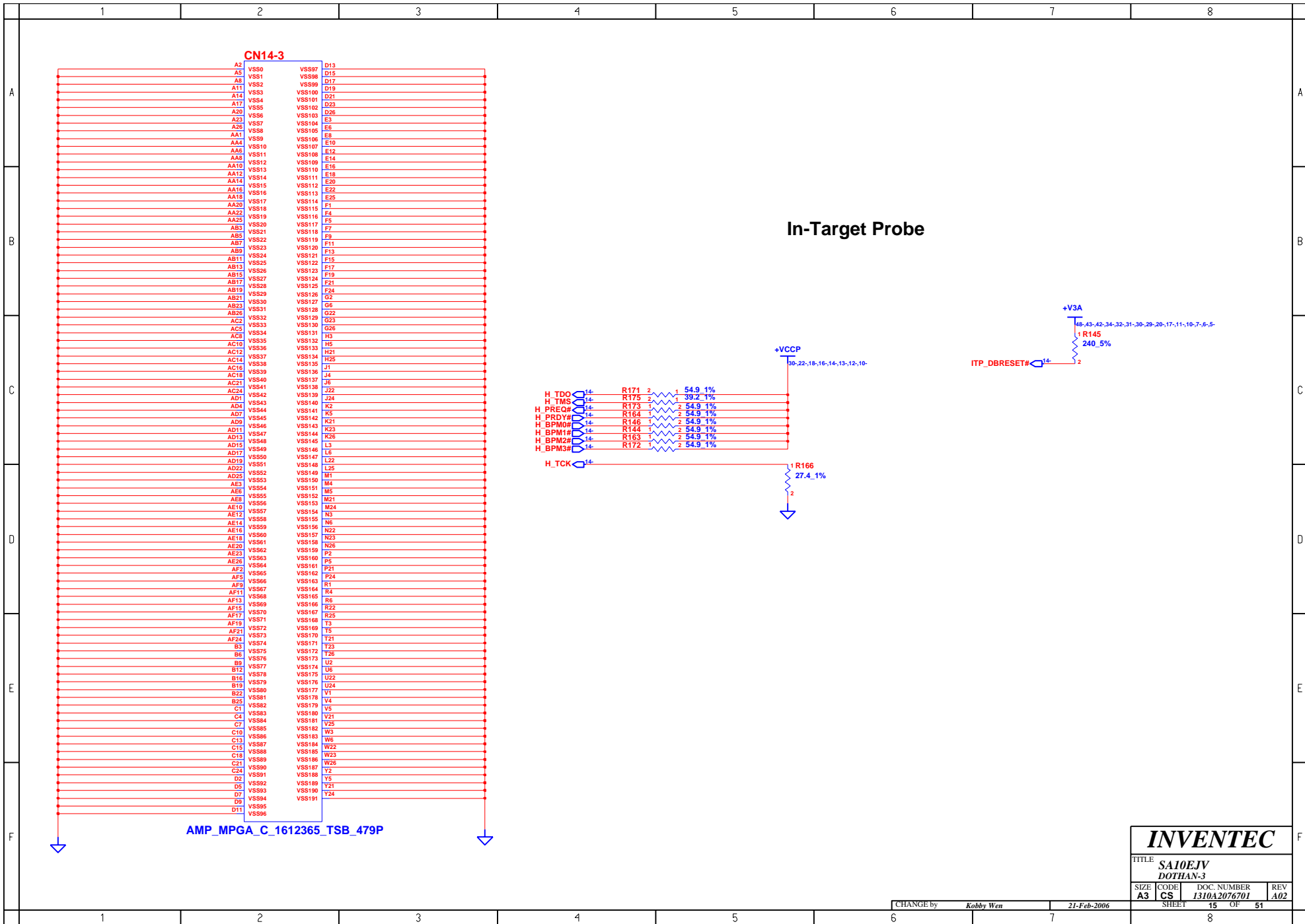

CN14-3

AMP_MPGA_C_1612365_TSB_479P

In-Target Probe

H_TDO	14	R171	2	1	54.9	1%
H_TMS	14	R175	2	1	39.2	1%
H_PREQ	14	R173	2	2	54.9	1%
H_PRDY#	14	R164	1	2	54.9	1%
H_BPM0#	14	R146	2	2	54.9	1%
H_BPM1#	14	R144	2	2	54.9	1%
H_BPM2#	14	R163	2	2	54.9	1%
H_BPM3#	14	R172	1	2	54.9	1%
H_TCK	14					

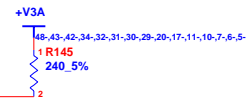

INVENTEC			
TITLE SA10EJV DOHAN-3			
SIZE A3	CODE CS	DOC. NUMBER I310A2076701	REV A02
CHANGE by Kobby Wen		21-Feb-2006	
SHEET 15		OF 51	

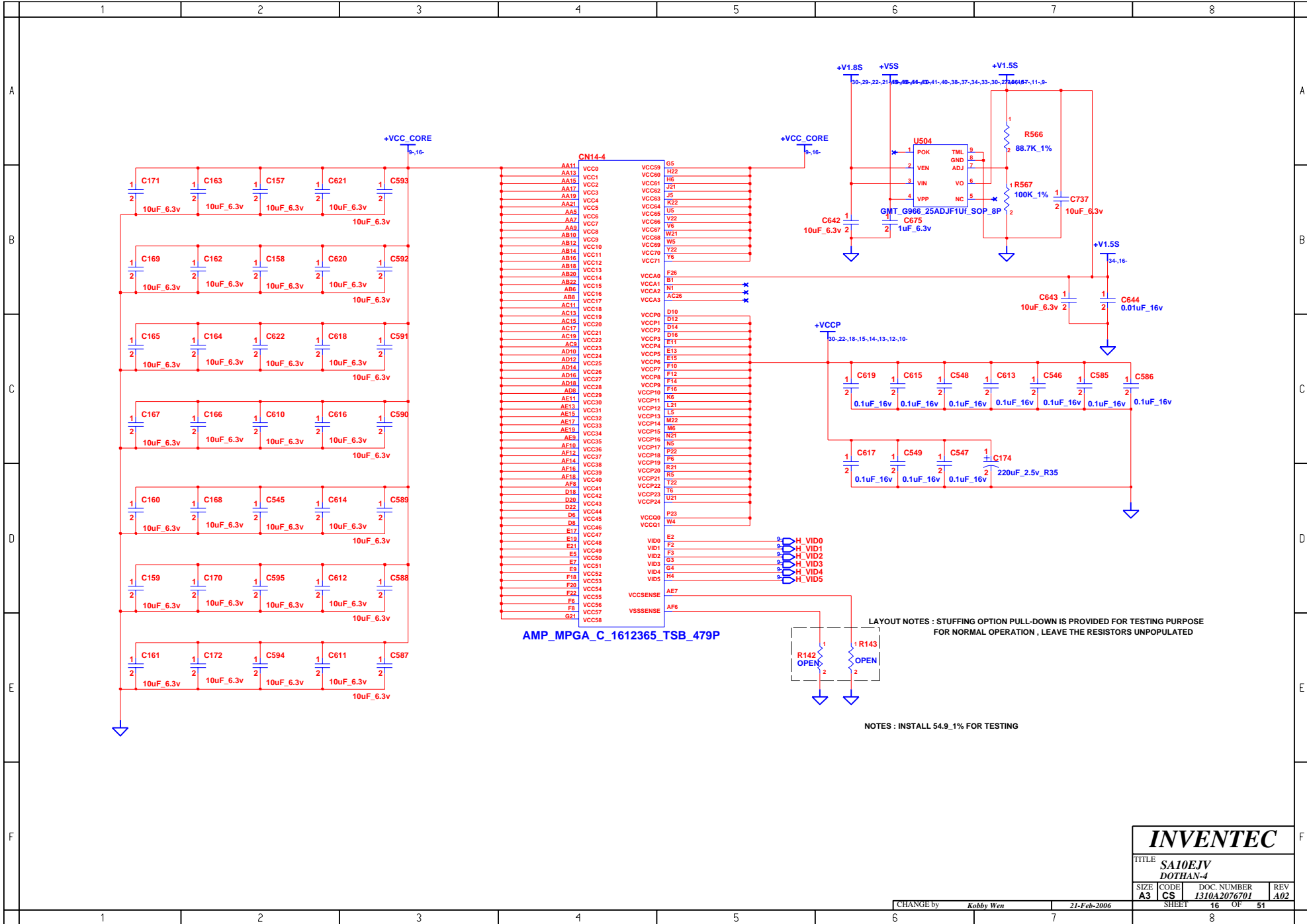

LAYOUT NOTES : STUFFING OPTION PULL-DOWN IS PROVIDED FOR TESTING PURPOSE FOR NORMAL OPERATION , LEAVE THE RESISTORS UNPOPULATED

NOTES : INSTALL 54.9_1% FOR TESTING

INVENTEC			
TITLE SA10EJV DO THAN-4			
SIZE A3	CODE CS	DOC. NUMBER 1310A2076701	REV A02
CHANGE by <i>Kobby Wen</i>		21-Feb-2006	
SHEET		16	OF 51

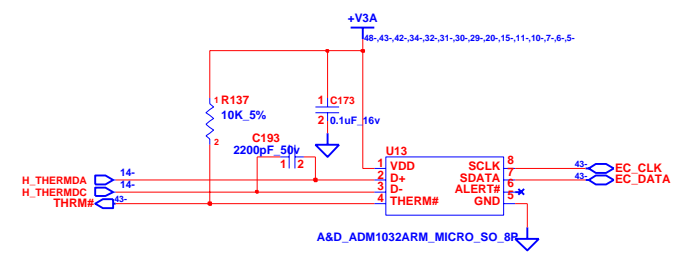
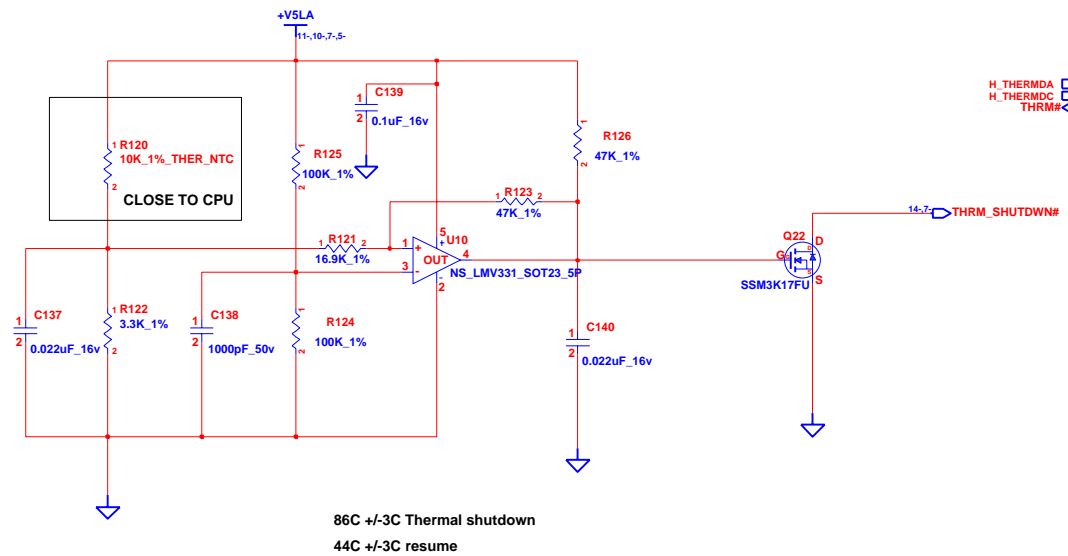
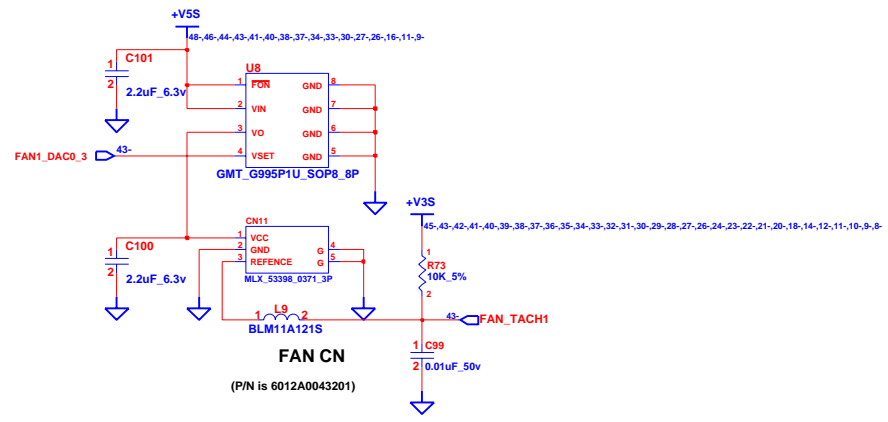

INVENTEC			
TITLE SA10EJV			
THERMAL & FAN CONTROLLER			
SIZE A3	CODE CS	DOC. NUMBER 1310A2076701	REV A02
CHANGE by <i>Kobby Wen</i>		SHEET 17	OF 51

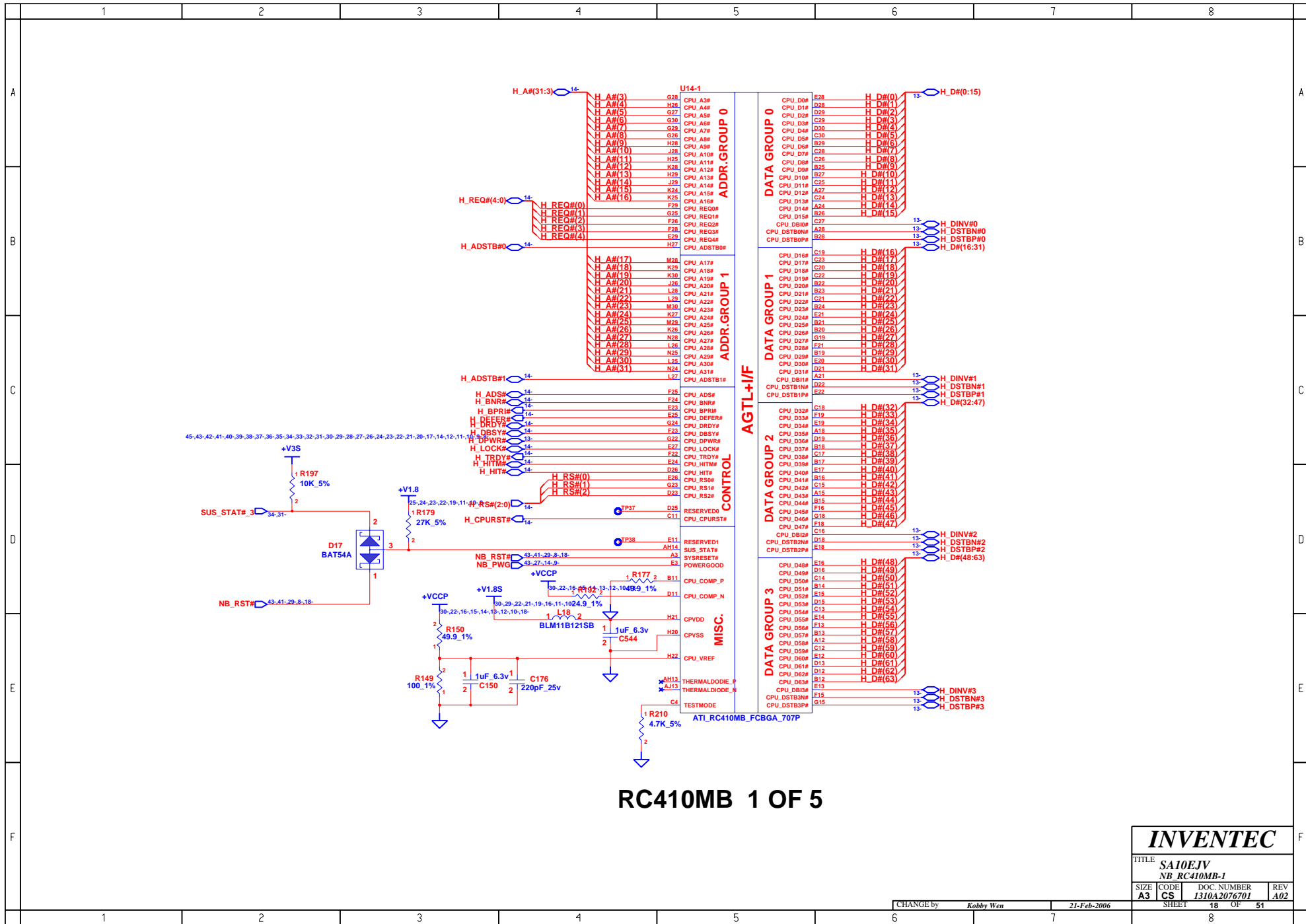

RC410MB 1 OF 5

INVENTEC

TITLE			
SA10EJV			
NB_RC410MB-1			
SIZE	CODE	DOC. NUMBER	REV
A3	CS	1310A2076701	A02

CHANGE by	Kobby Wen	21-Feb-2006	SHEET	18	OF	51
-----------	-----------	-------------	-------	----	----	----

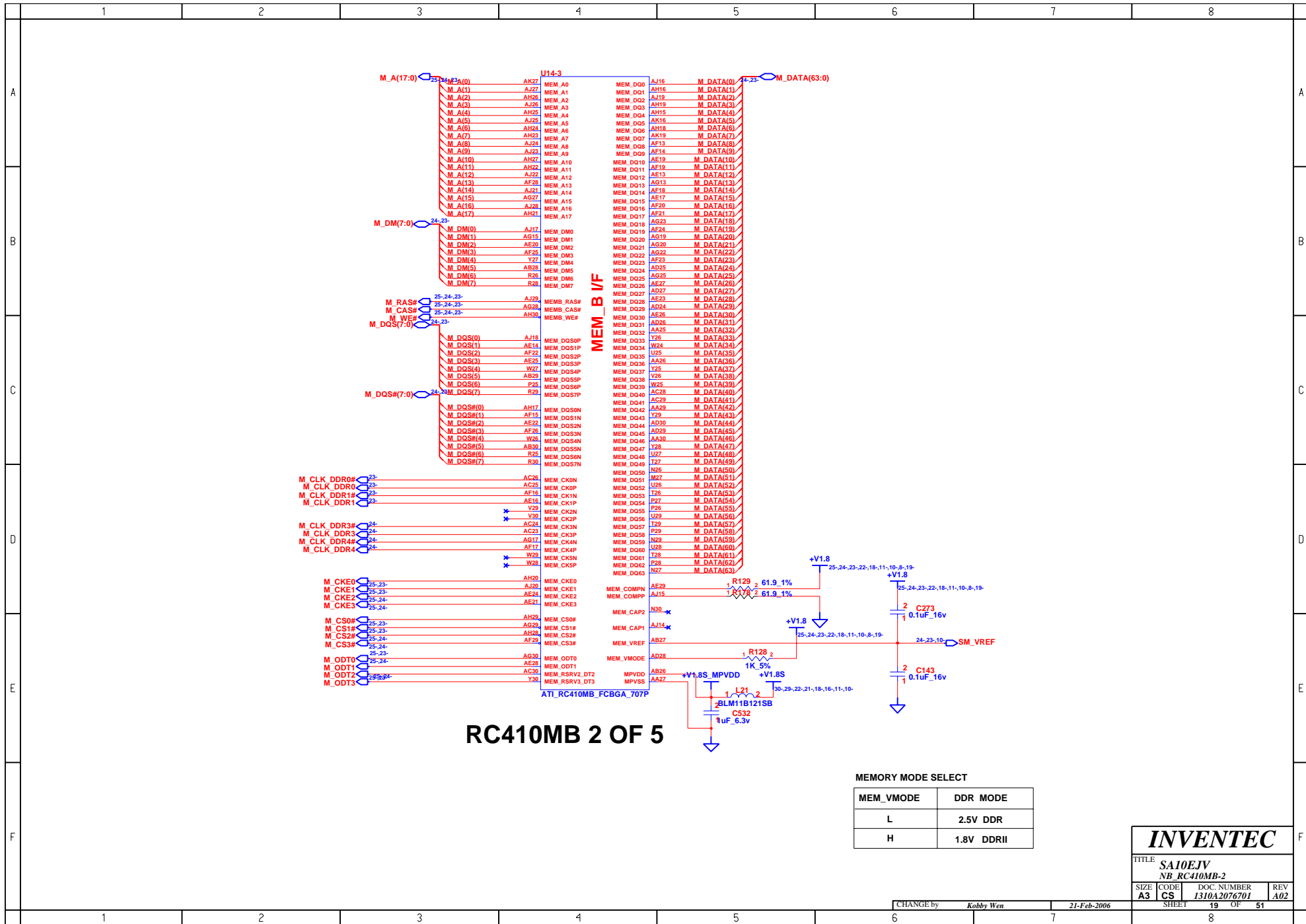

MEMORY MODE SELECT

MEM_VM0DE	DDR MODE
L	2.5V DDR
H	1.8V DDRII

INVENTEC

TITLE SAI0EJV
NB RC410MB-2

SIZE A3	CODE CS	DOC. NUMBER 1310A2076701	REV A02
---------	---------	--------------------------	---------

CHANGE by Kobby Wen 21-Feb-2006 SHEET 19 OF 51

BMREQ#	DACHSYNC	DACVSYNC	FSB
0	0	1	133M 7X0
0	0	0	100M 7X5

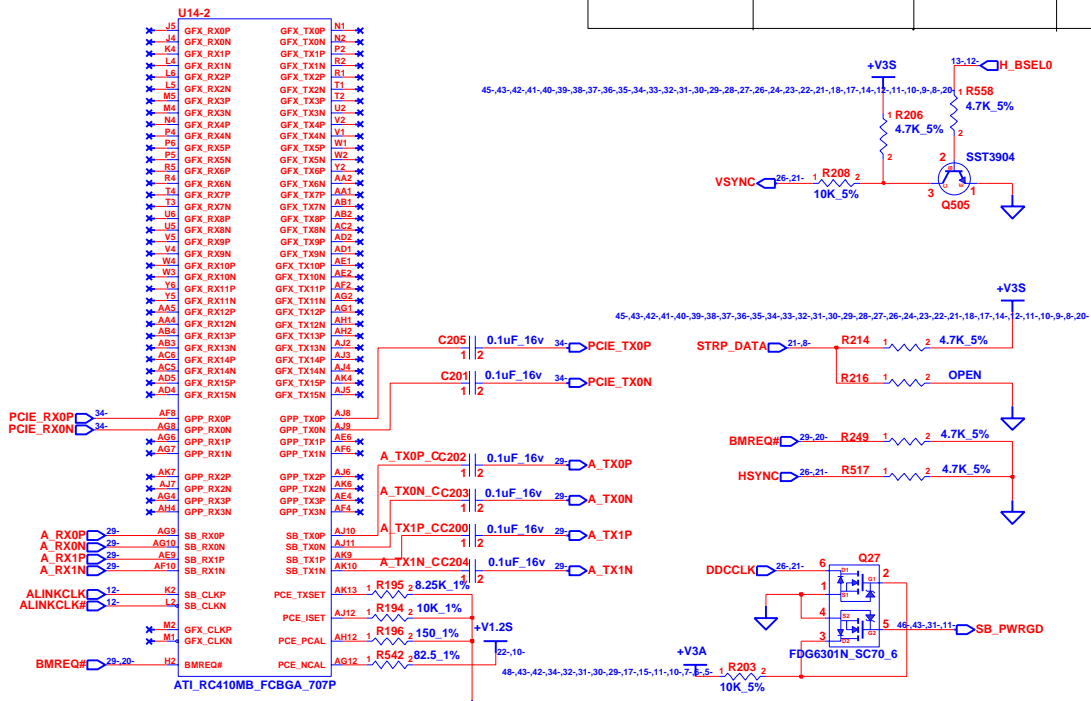

RC410MB 3 OF 5

0: MOBILE CPU
1: DESKTOP CPU

INVENTEC			
TITLE: SA10EJV NB RC410MB-3			
SIZE: A3	CODE: CS	DOC. NUMBER: 1310A2076701	REV: A02
CHANGE by: Kobby Wen		21-Feb-2006	
SHEET: 20		OF: 51	

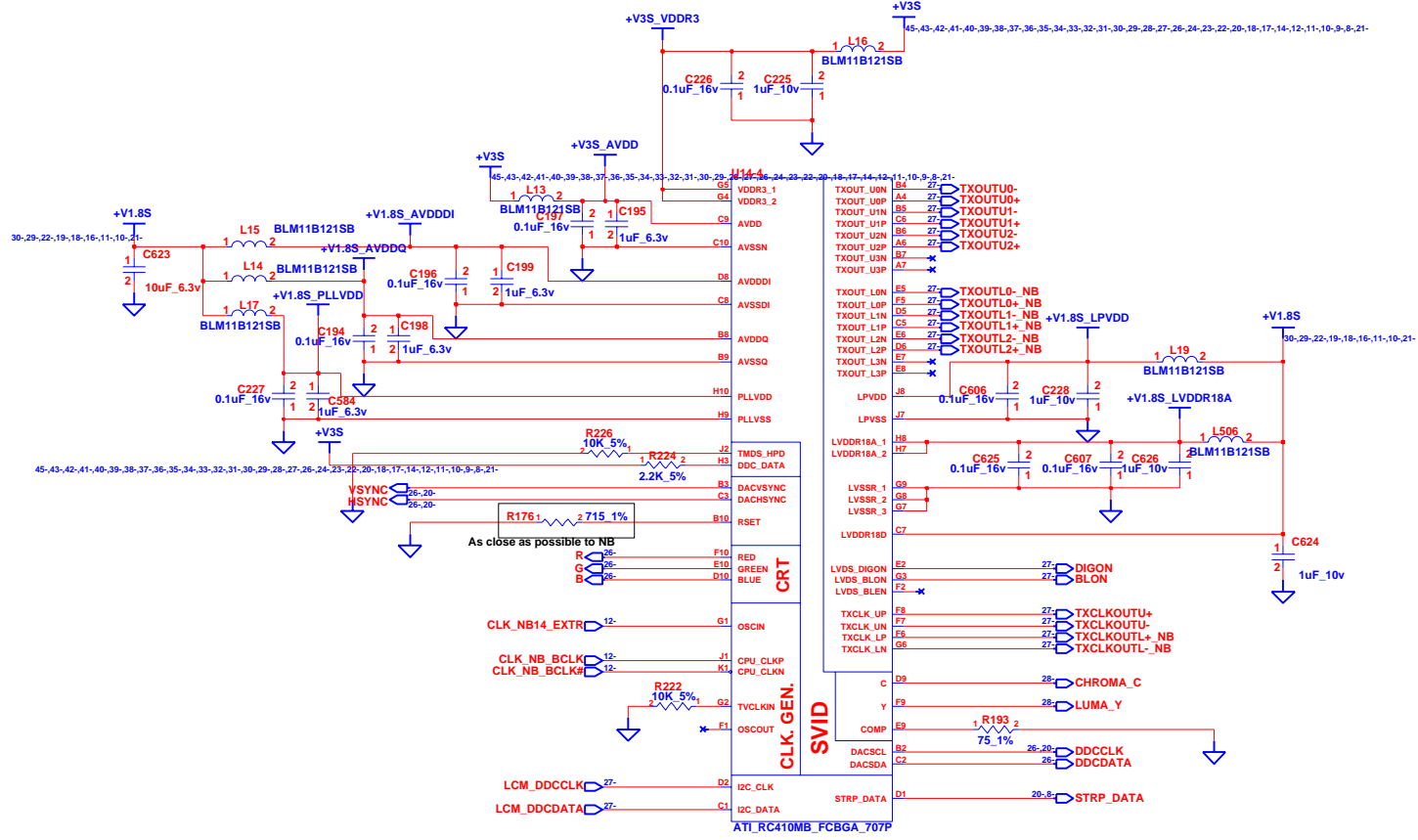

RC410MB 4 OF 5

INVENTEC			
TITLE: SA10EJV NB_RC410MB-4			
SIZE: A3	CODE: CS	DOC NUMBER: 1310A2076701	REV: A02
CHANGE by: Kobby Wen		21-Feb-2006	SHEET 21 OF 51

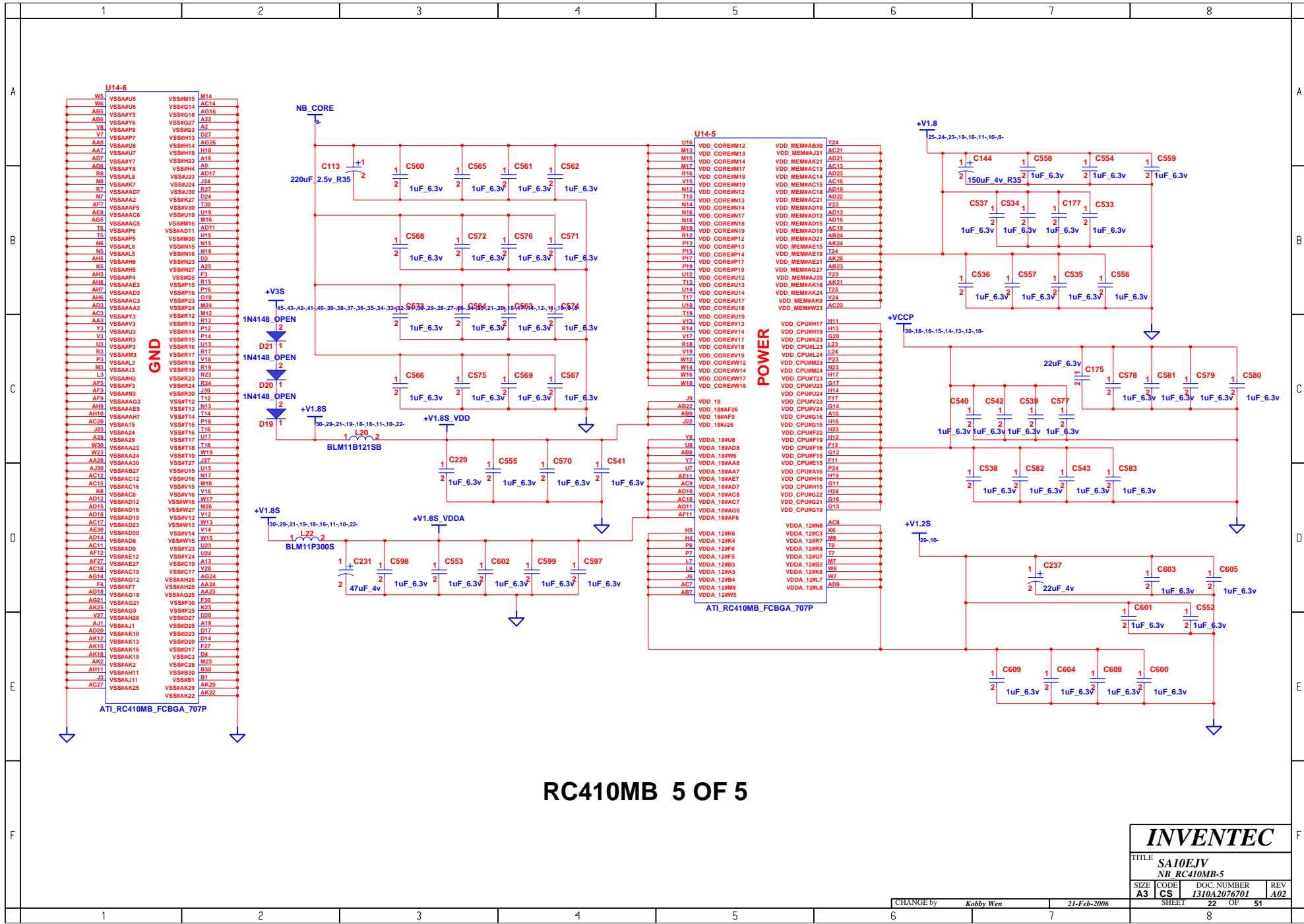

RC410MB 5 OF 5

INVENTEC

TITLE SA10EJV NB_RC410MB-5			
SIZE A3	CODE CS	DOC. NUMBER 1310A2076701	REV A02
CHANGE by Kobby Wen		21-Feb-2006	
SHEET 22		OF 51	

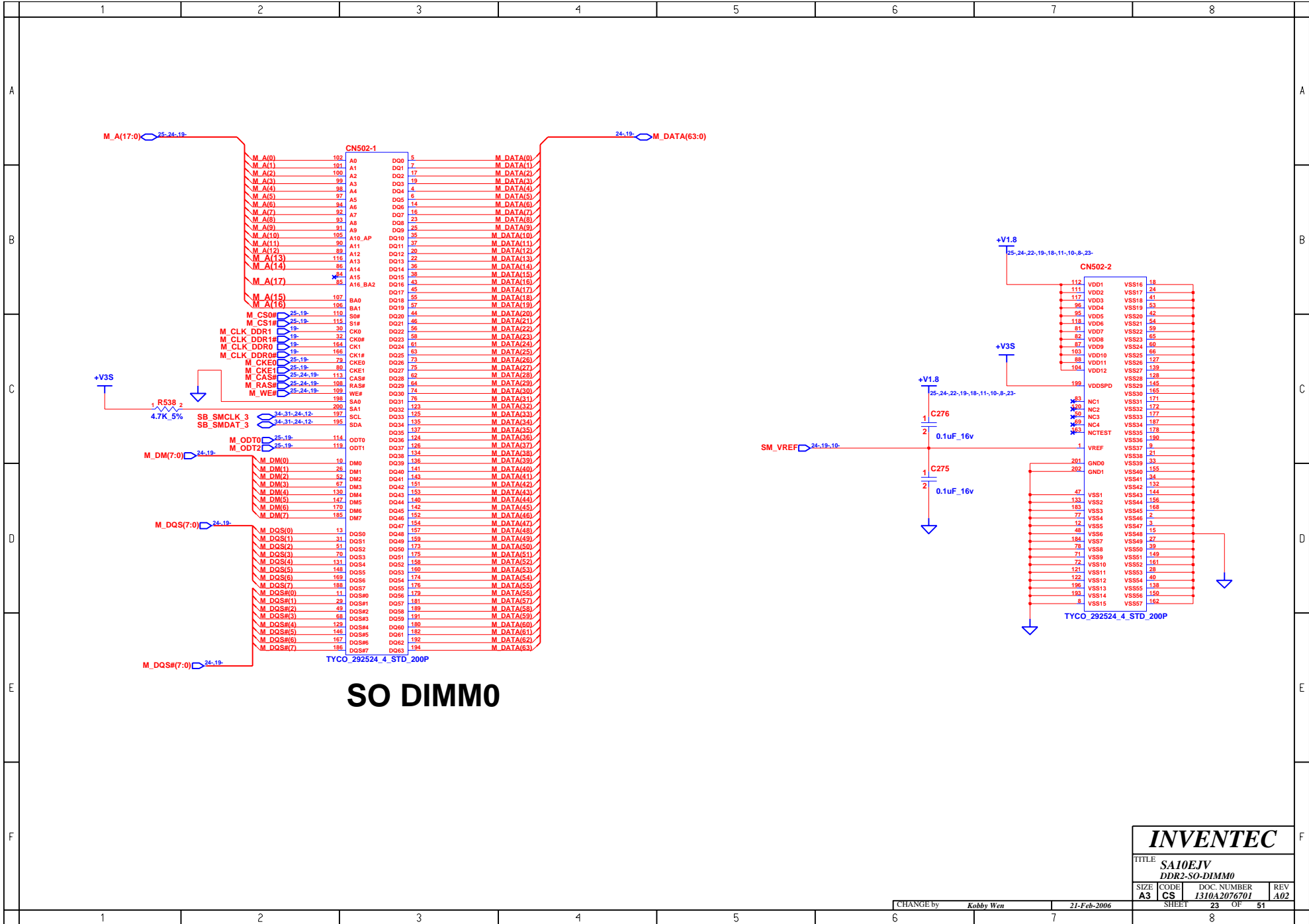

SO DIMM0

INVENTEC

TITLE			
SA10EJV			
DDR2-SO-DIMM0			
SIZE	CODE	DOC. NUMBER	REV
A3	CS	1310A2076701	A02
CHANGE by			SHEET
Kobby Wen			23 OF 51
21-Feb-2006			8

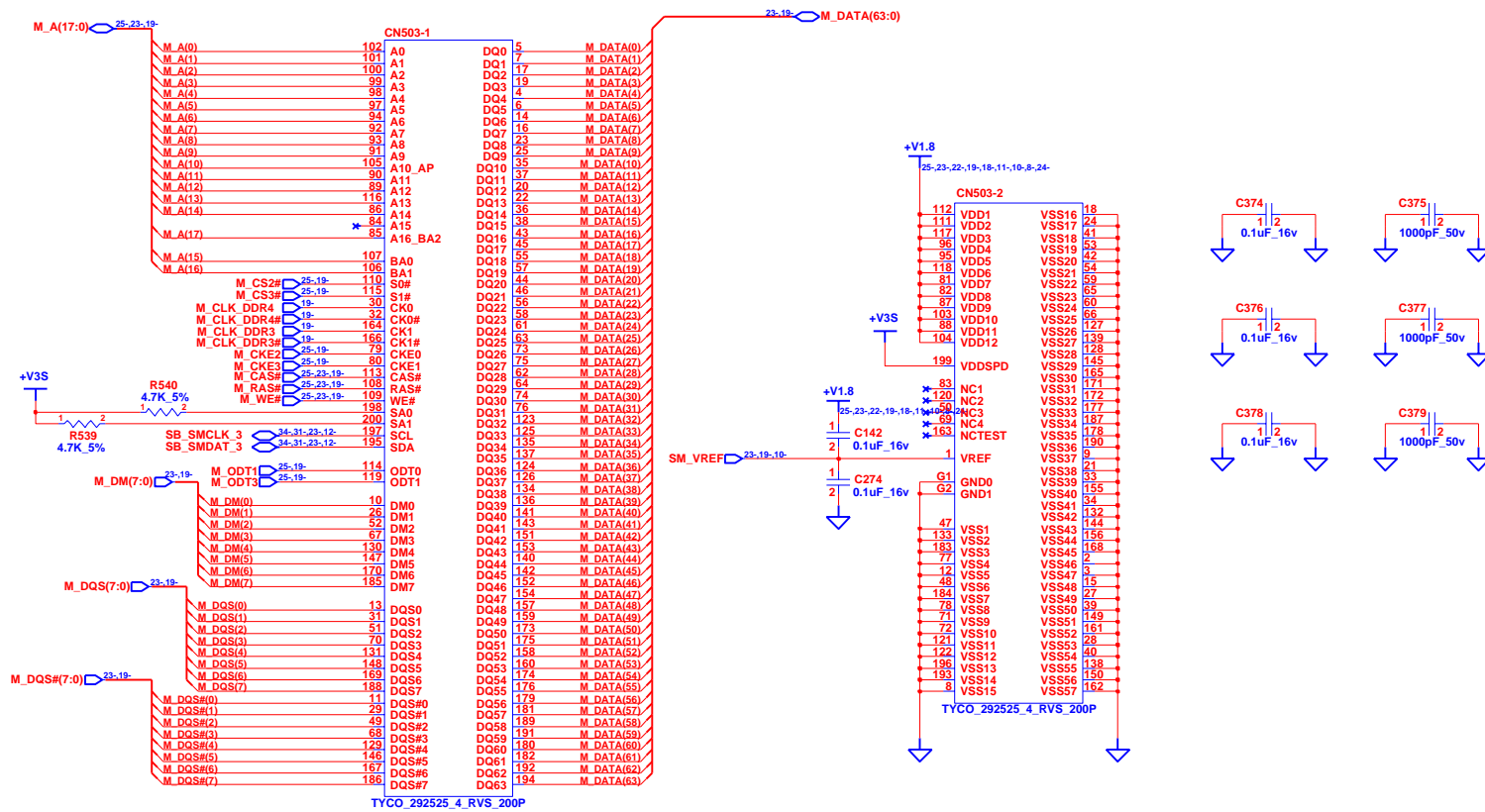

SO DIMM1

INVENTEC			
TITLE SA10EJV DDR2-SO-DIMM1			
SIZE A3	CODE CS	DOC. NUMBER 1310A2076701	REV A02
CHANGE by <i>Kobby Wen</i>		21-Feb-2006	SHEET 24 OF 51

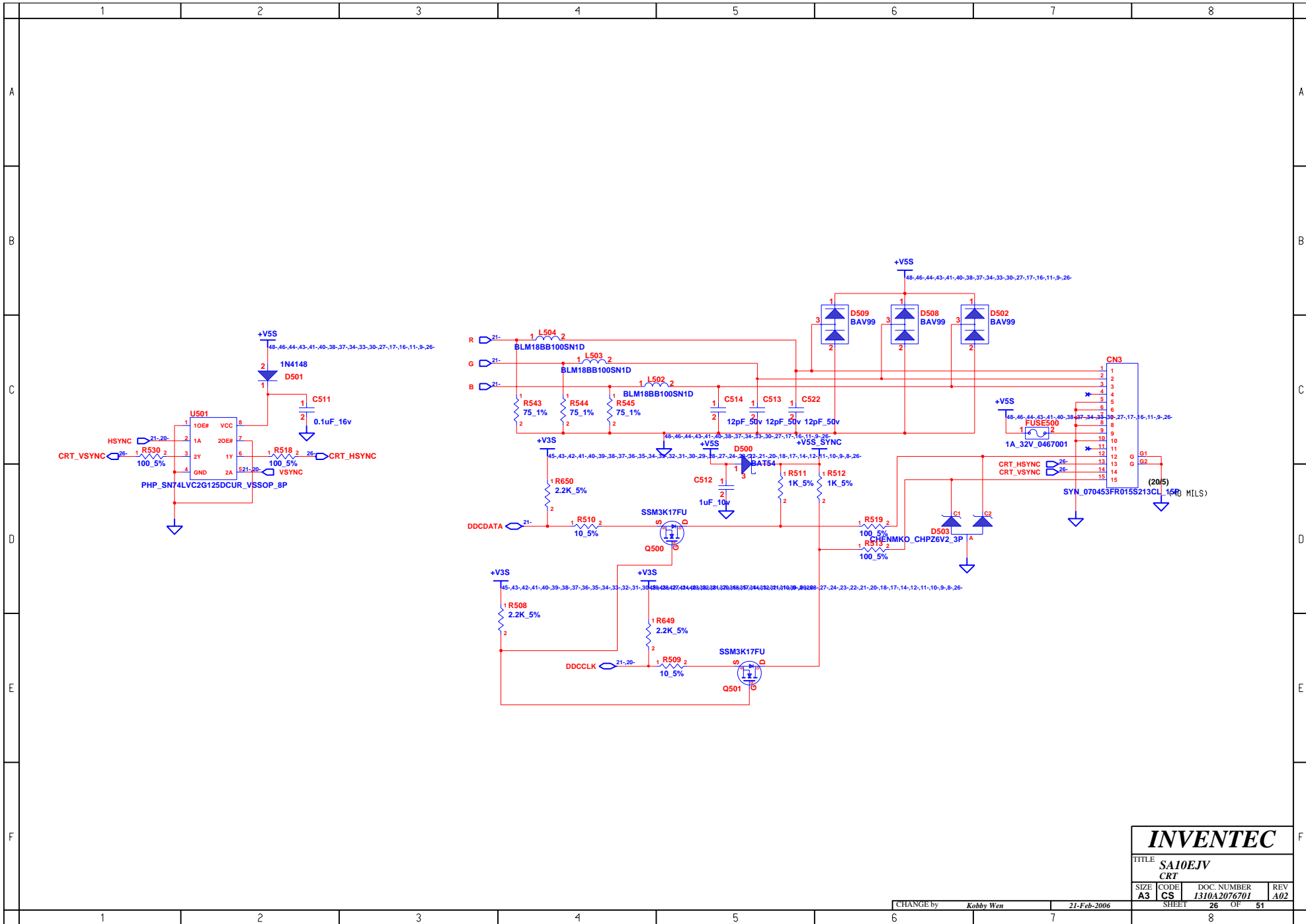

INVENTEC			
TITLE SA10EJV CRT			
SIZE A3	CODE CS	DOC. NUMBER 1310A2076701	REV A02
CHANGE by Kobby Wen		21-Feb-2006	
SHEET 26		OF 51	

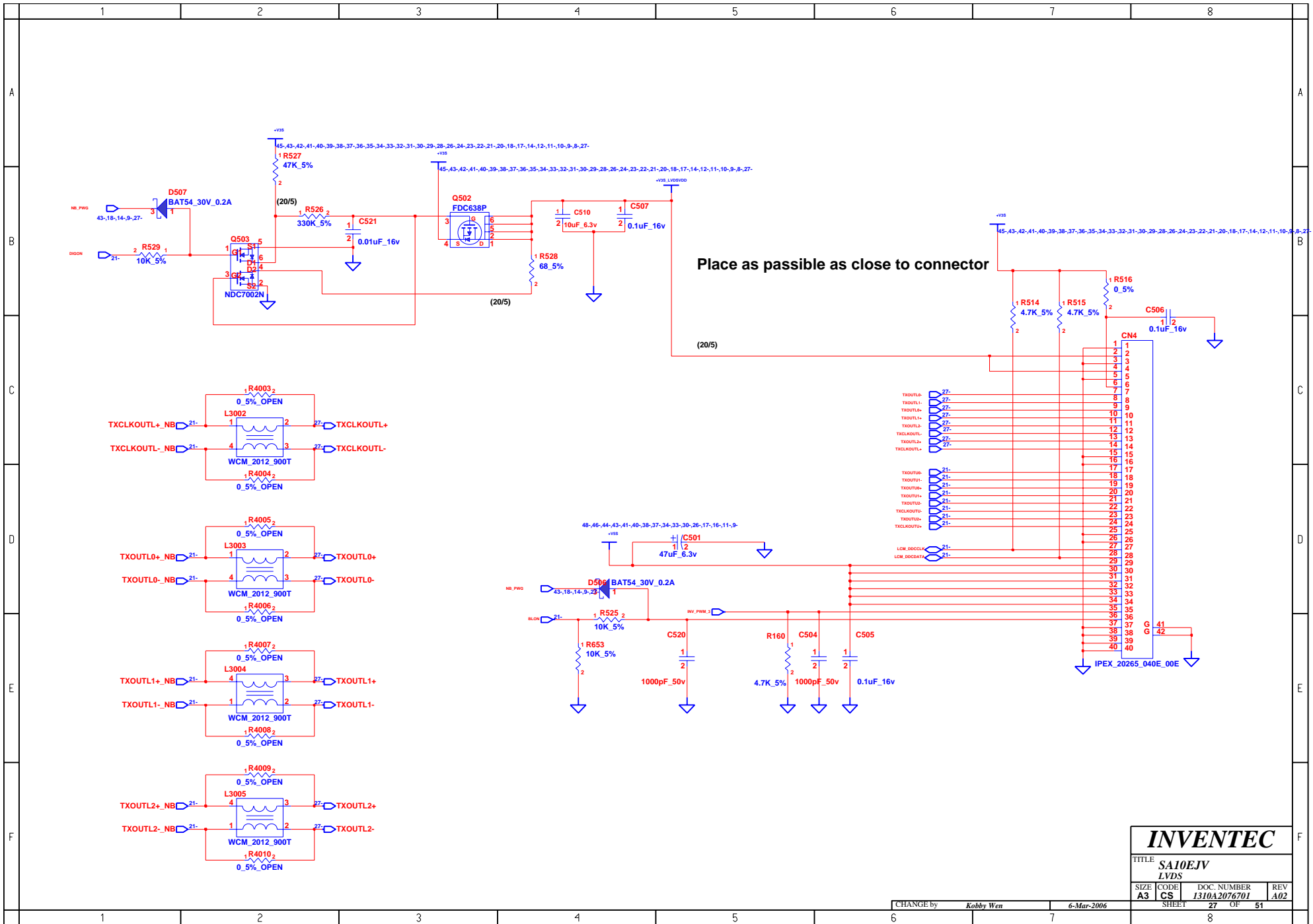

INVENTEC			
TITLE SA10EJV			
LDVS			
SIZE A3	CODE CS	DOC. NUMBER 1310A2076701	REV A02
CHANGE by Kobby Wen		6-Mar-2006	SHEET 27 OF 51

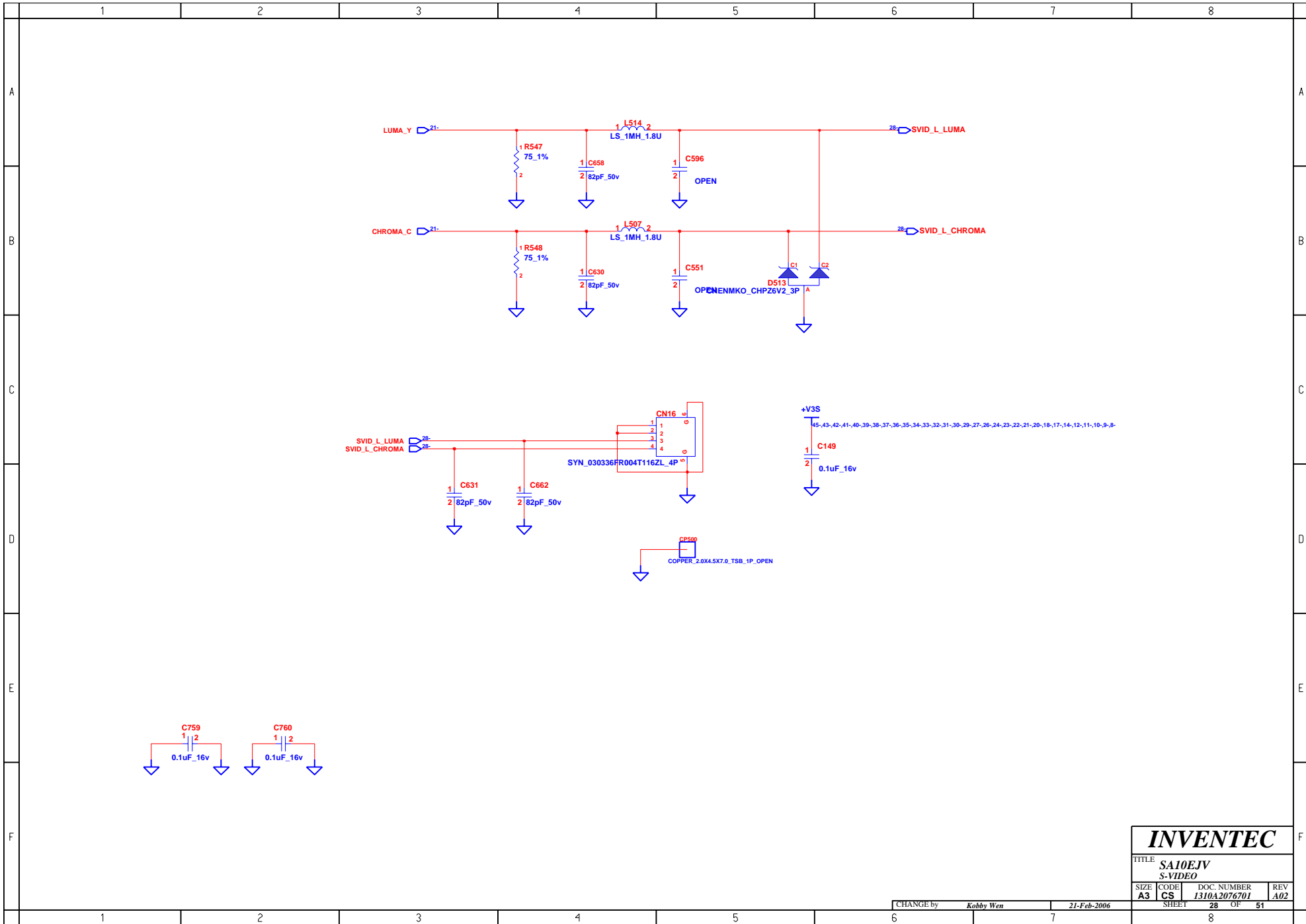

INVENTEC

TITLE **SA10EJV**
S-VIDEO

SIZE A3	CODE CS	DOC. NUMBER 1310A2076701	REV A02
CHANGE by <i>Kobby Wen</i>		21-Feb-2006	
SHEET 28		OF 51	

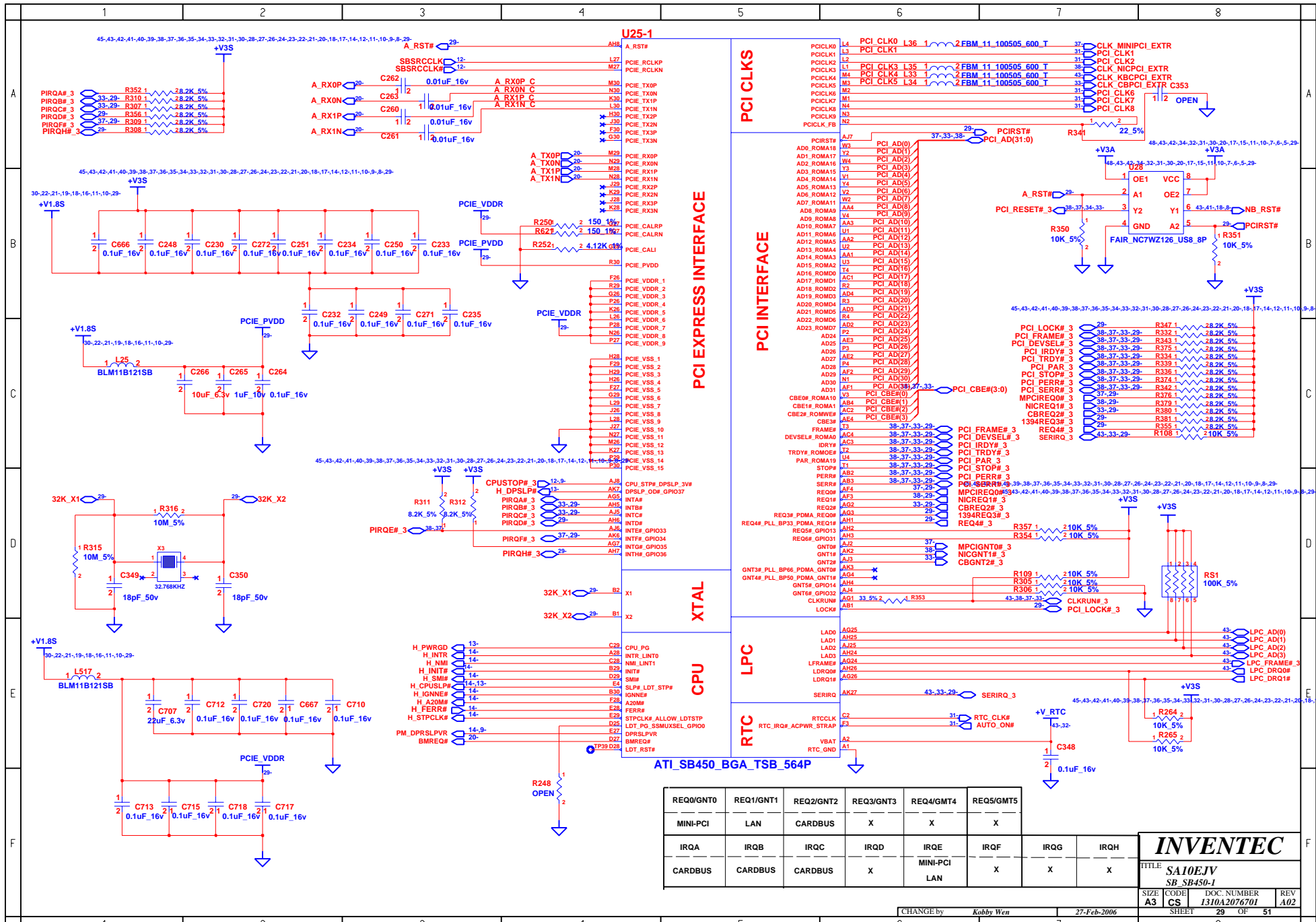

REQ0/GNT0	REQ1/GNT1	REQ2/GNT2	REQ3/GNT3	REQ4/GMT4	REQ5/GMT5
MINI-PCI	LAN	CARDBUS	X	X	X
IRQA	IRQB	IRQC	IRQD	IRQE	IRQF
CARDBUS	CARDBUS	CARDBUS	X	MINI-PCI LAN	X

INVENTEC

TITLE
SA10EJV
SB_SB450-1

SIZE A3	CODE CS	DOC. NUMBER 1310A2076701	REV A02
SHEET 8		OF 51	

CHANGE by *Kobby Wen* 27-Feb-2006

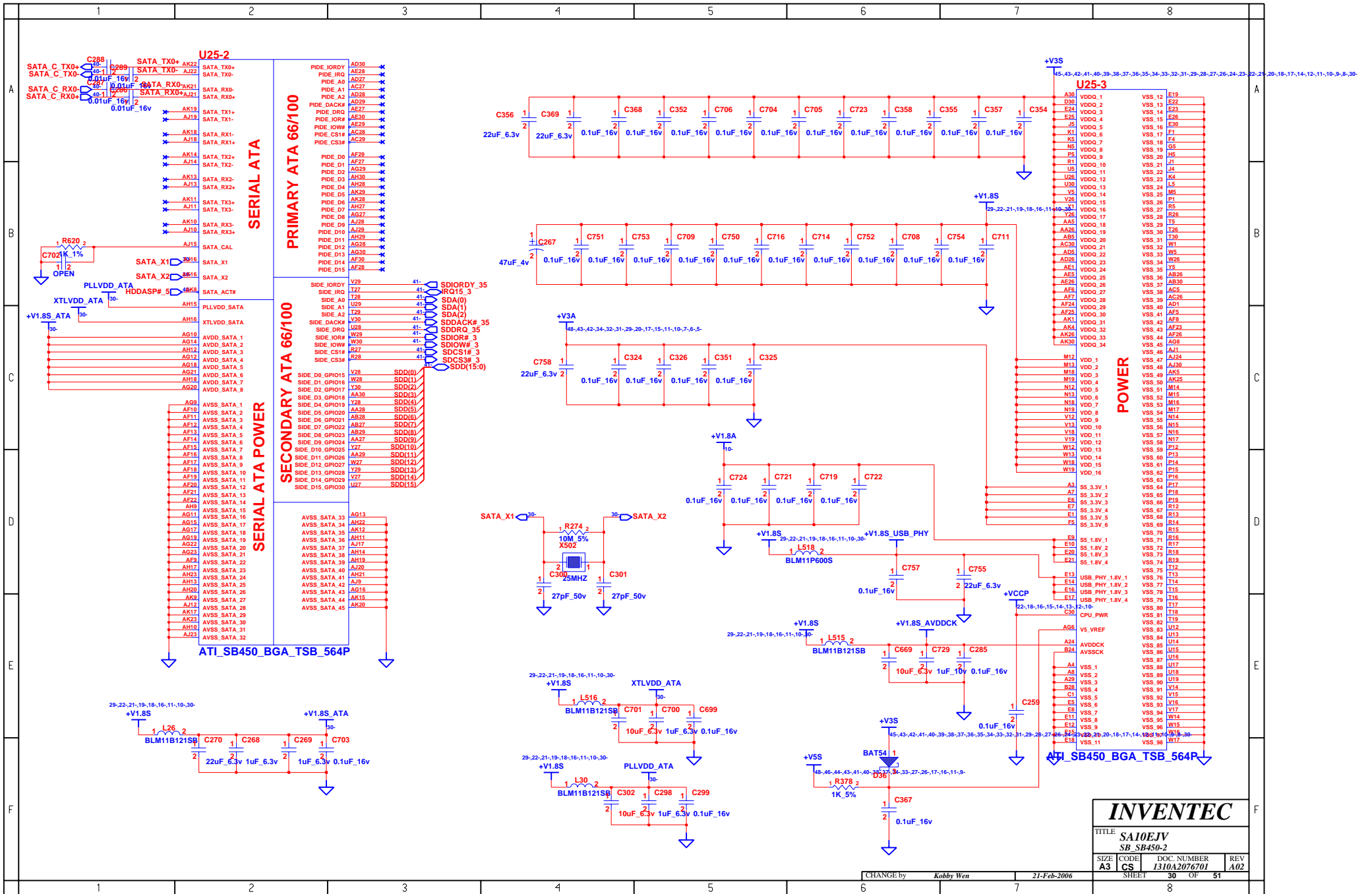

INVENTEC

TITLE			
SA10EJV			
SB_SB450-2			
SIZE	CODE	DOC. NUMBER	REV
A3	CS	1310A2076701	A02
SHEET		OF	
30		51	

CHANGE by *Kobby Wen* 21-Feb-2006

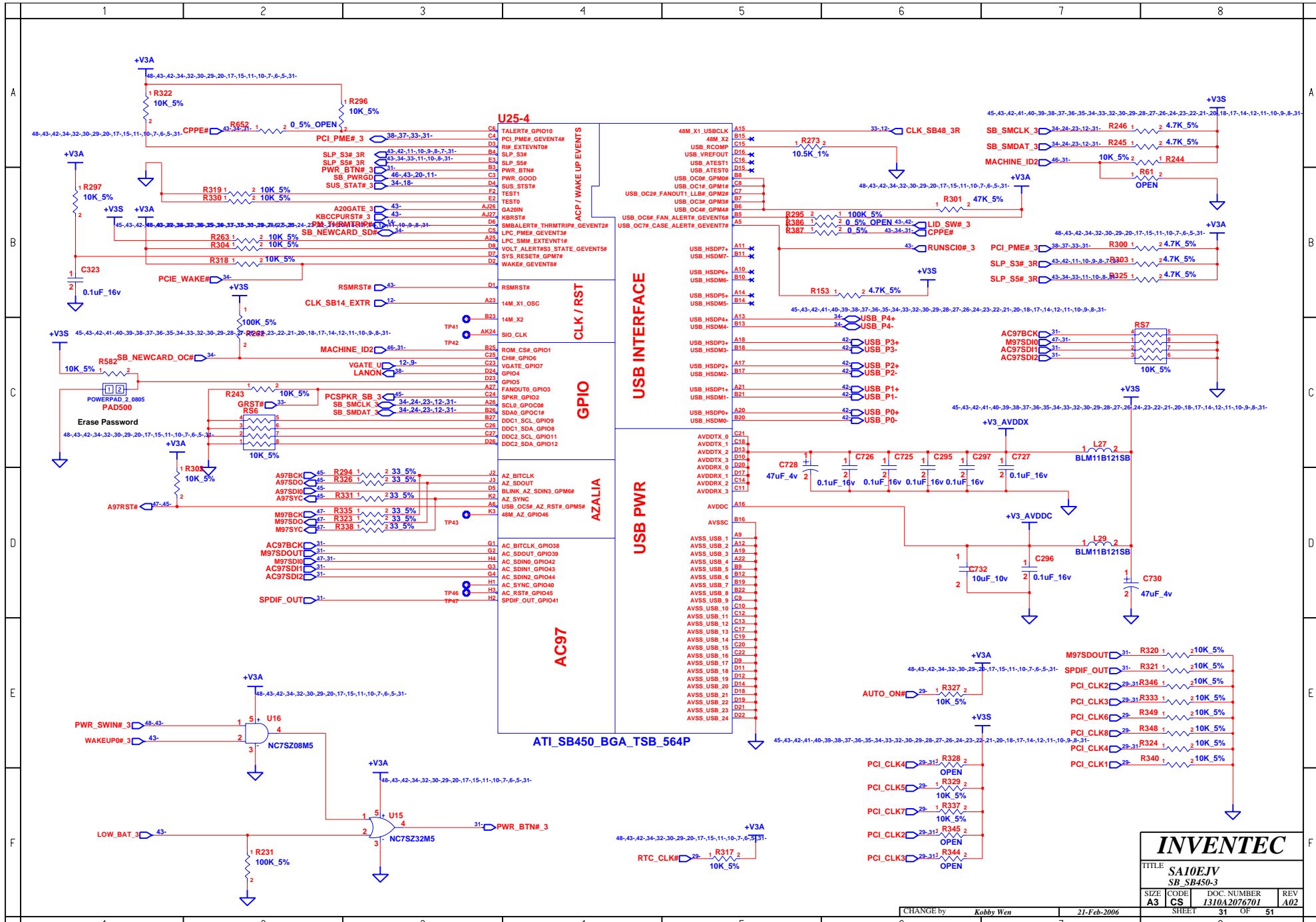

INVENTEC

TITLE: SA10EJV
SB_SB450-3

SIZE	CODE	DOC. NUMBER	REV
A3	CS	1310A2076701	A02

SHEET 31 OF 51

CHANGE by *Kobby Wen* 21-Feb-2006

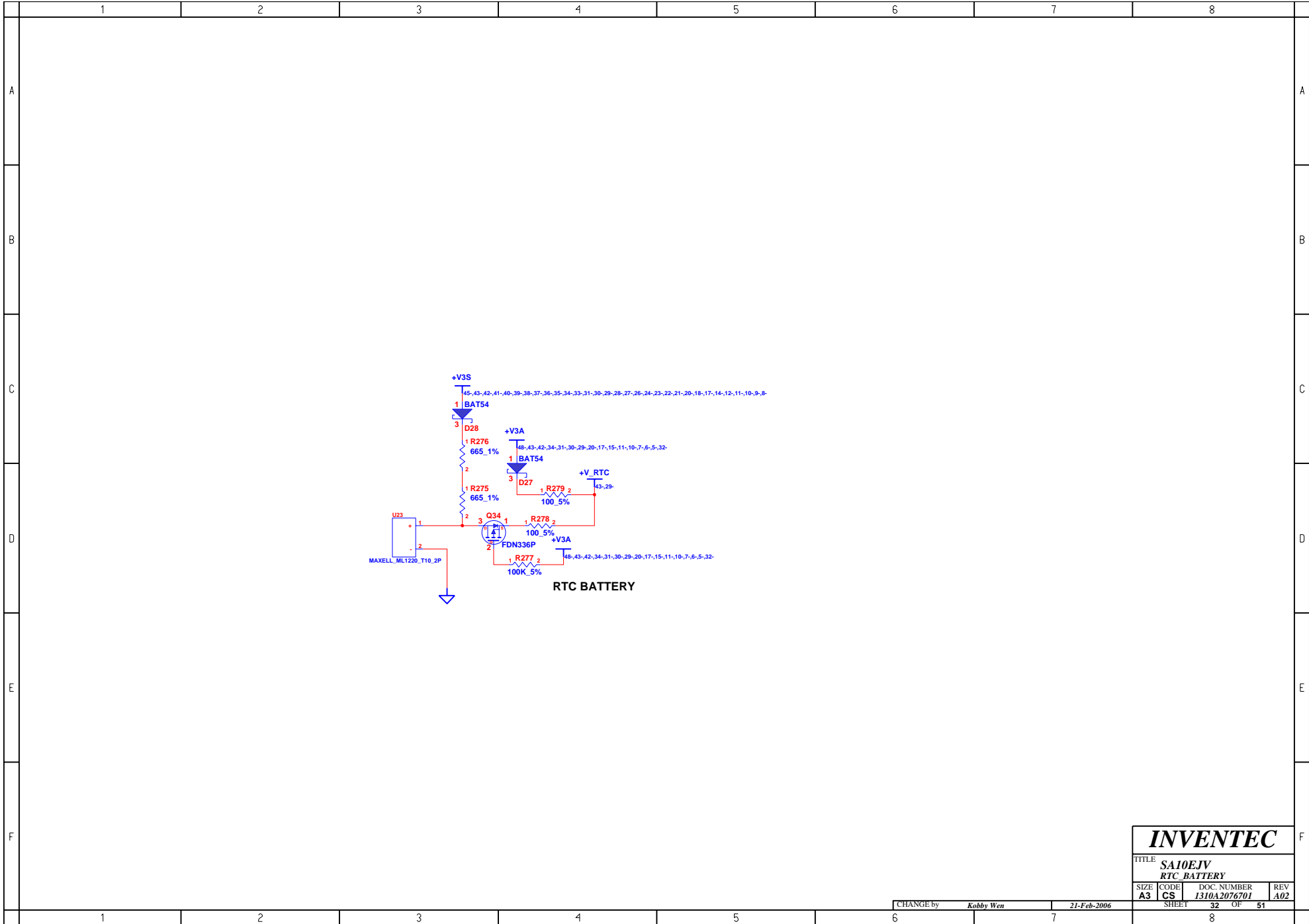

INVENTEC

TITLE			
SA10EJV			
RTC BATTERY			
SIZE	CODE	DOC. NUMBER	REV
A3	CS	1310A2076701	A02

CHANGE by *Kobby Wen* 21-Feb-2006

SHEET 32 OF 51

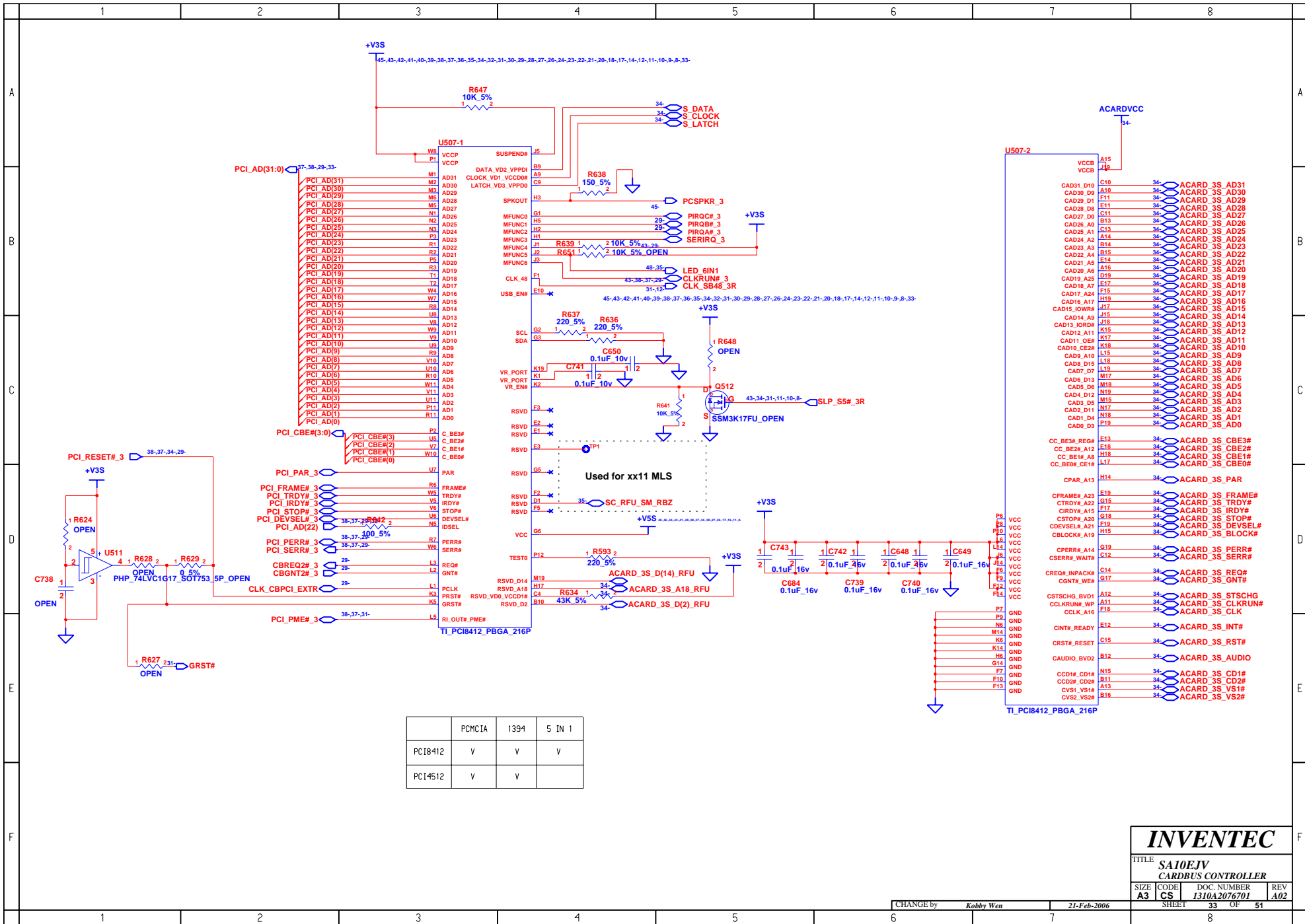

INVENTEC

TITLE
**SA10EJV
CARBUS CONTROLLER**

SIZE A3	CODE CS	DOC. NUMBER 1310A2076701	REV A02
-------------------	-------------------	------------------------------------	-------------------

CHANGE by *Kobby Wen* 21-Feb-2006

SHEET 33 OF 51

R654
4.7K_5%

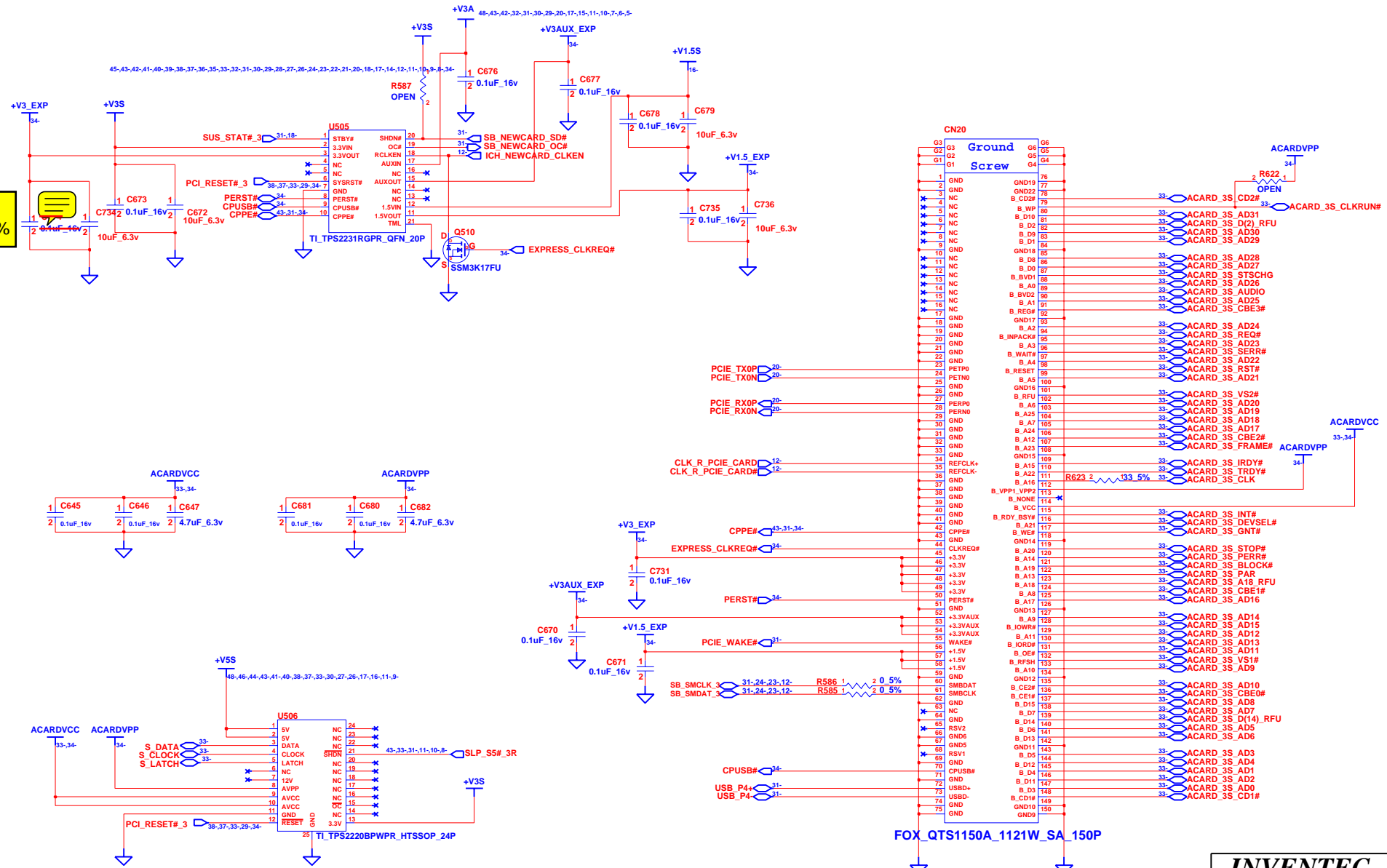

INVENTEC

TITLE: SA10EJV
PCMCIA & EXPRESS CARD

SIZE	CODE	DOC. NUMBER	REV
A3	CS	1310A2076701	A02

CHANGE by	DATE	SHEET	OF
Kobby Wen	21-Feb-2006	34	51

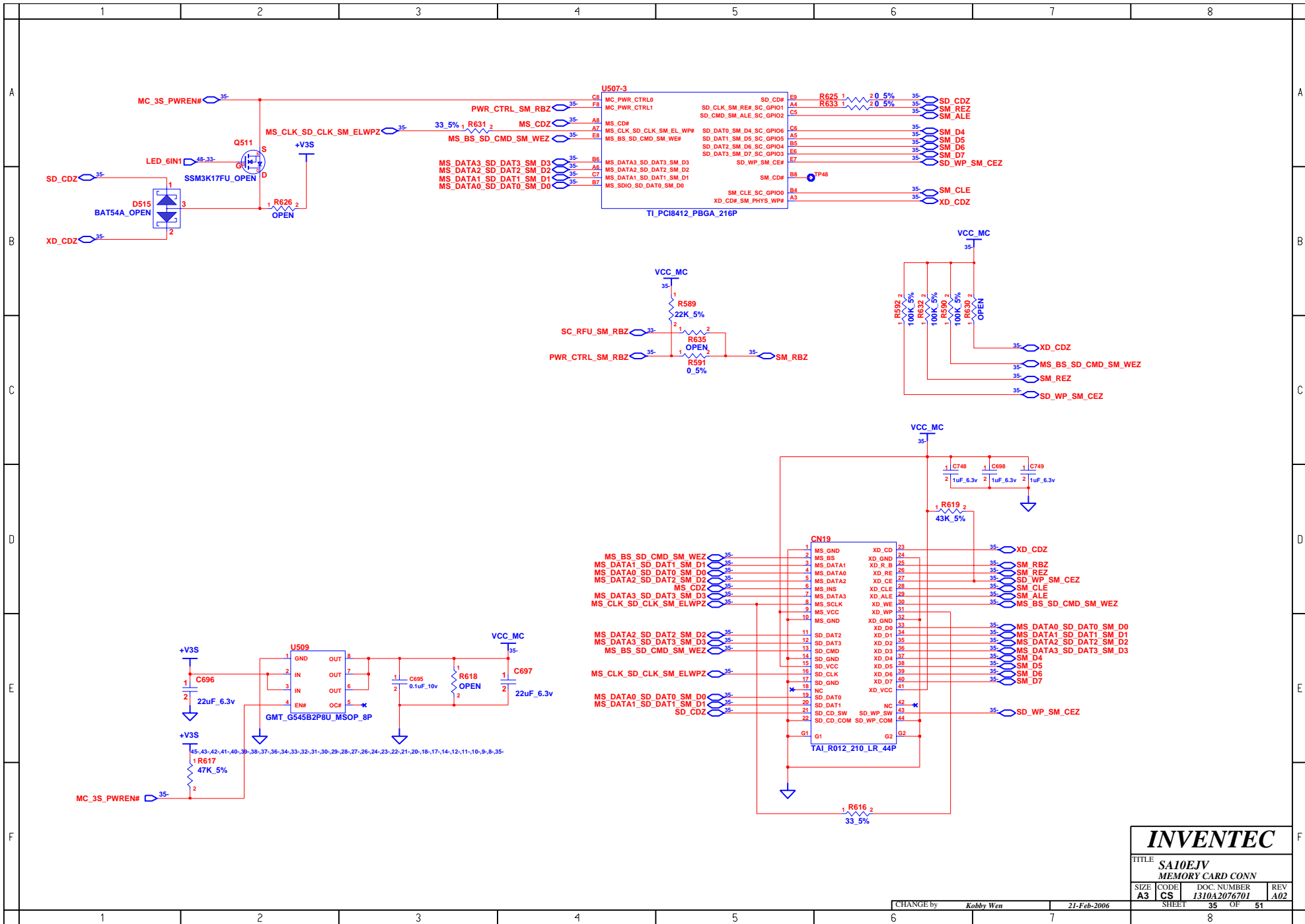

INVENTEC

TITLE: SA10EJV
MEMORY CARD CONN

SIZE	CODE	DOC. NUMBER	REV
A3	CS	1310A2076701	A02

CHANGE by: Kobby Wen 21-Feb-2006

SHEET 35 OF 51

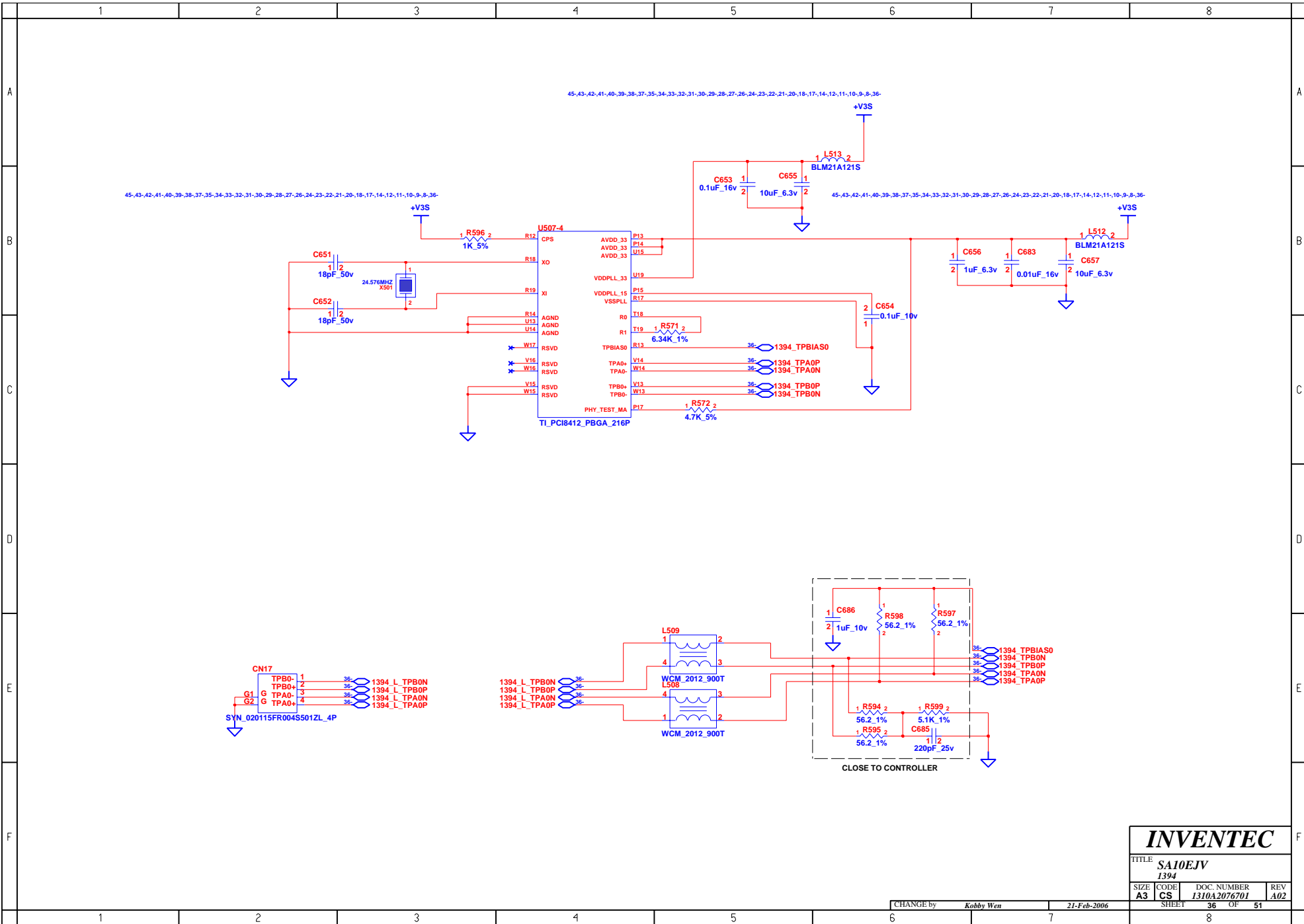

INVENTEC			
TITLE SA10EJV			
1394			
SIZE	CODE	DOC. NUMBER	REV
A3	CS	1310A2076701	A02
CHANGE by		21-Feb-2006	
Kobby Wen		SHEET 36 OF 51	

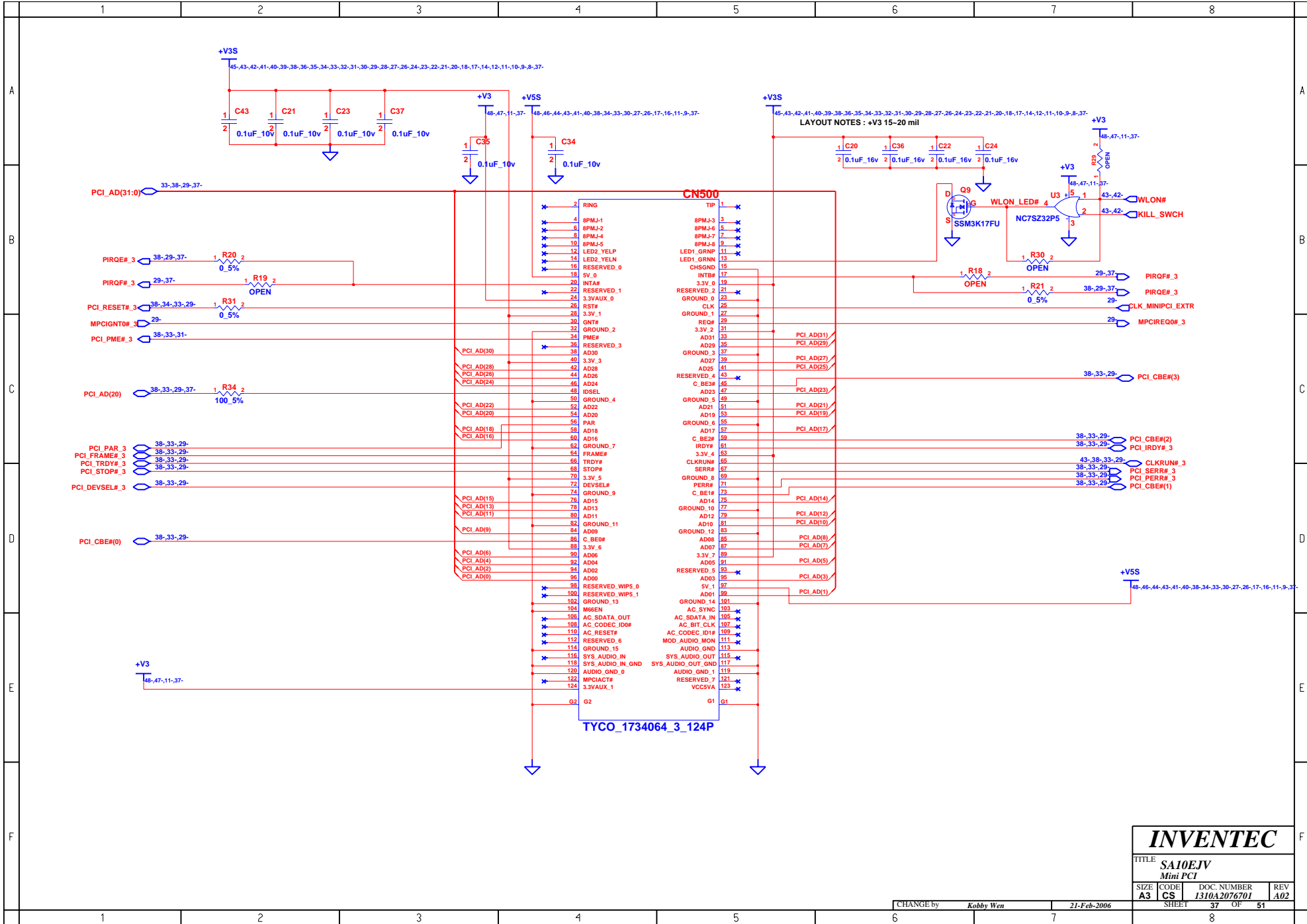

INVENTEC			
TITLE SA10EJV Mini PCI			
SIZE A3	CODE CS	DOC. NUMBER 1310A2076701	REV A02
CHANGE by Kobby Wen		21-Feb-2006	
SHEET 37		OF 51	

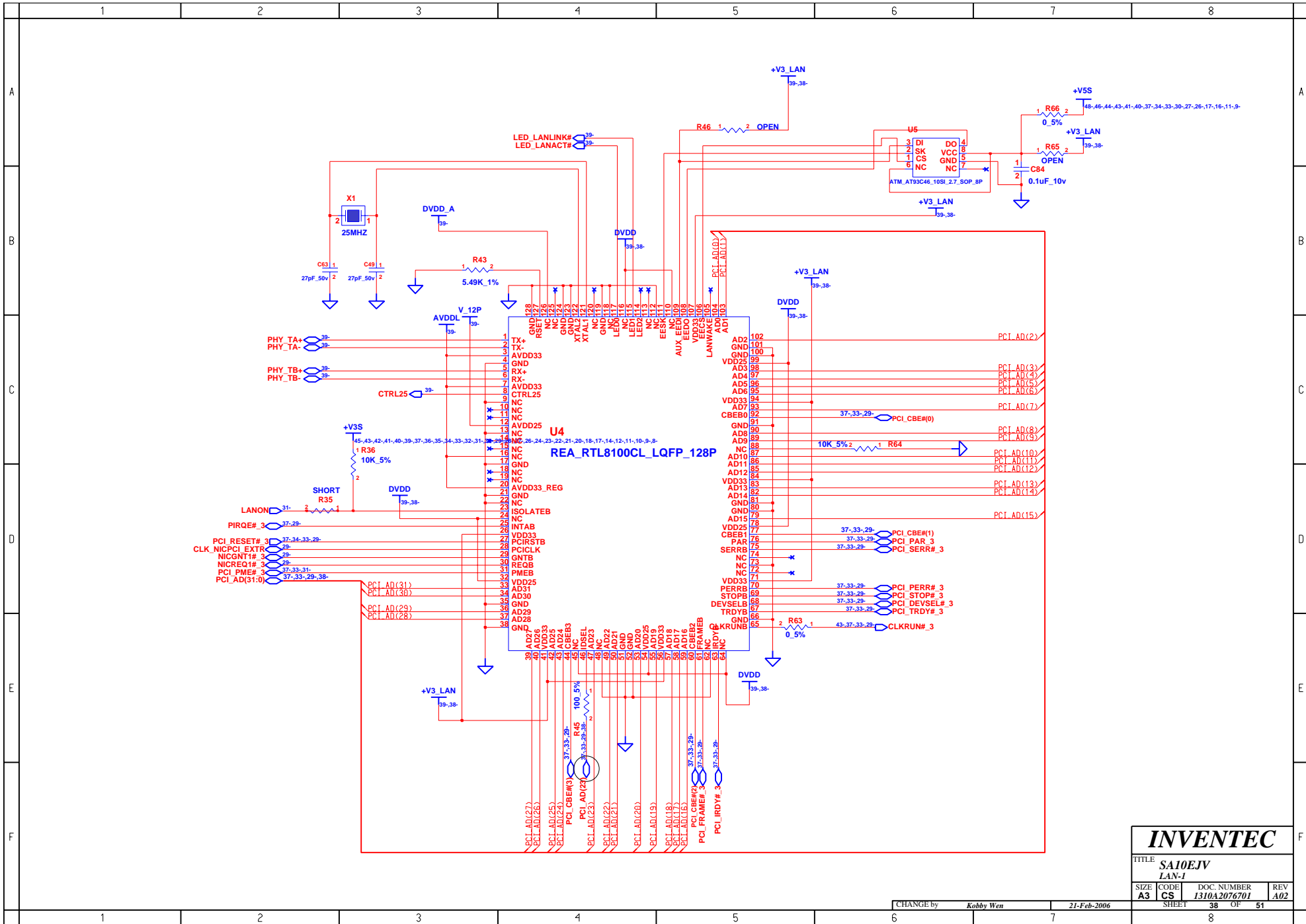

INVENTEC

TITLE
SA10EJV
LAN-1

SIZE	CODE	DOC. NUMBER	REV
A3	CS	1310A2076701	A02

CHANGE by *Kobby Wen* 21-Feb-2006

SHEET 38 OF 51

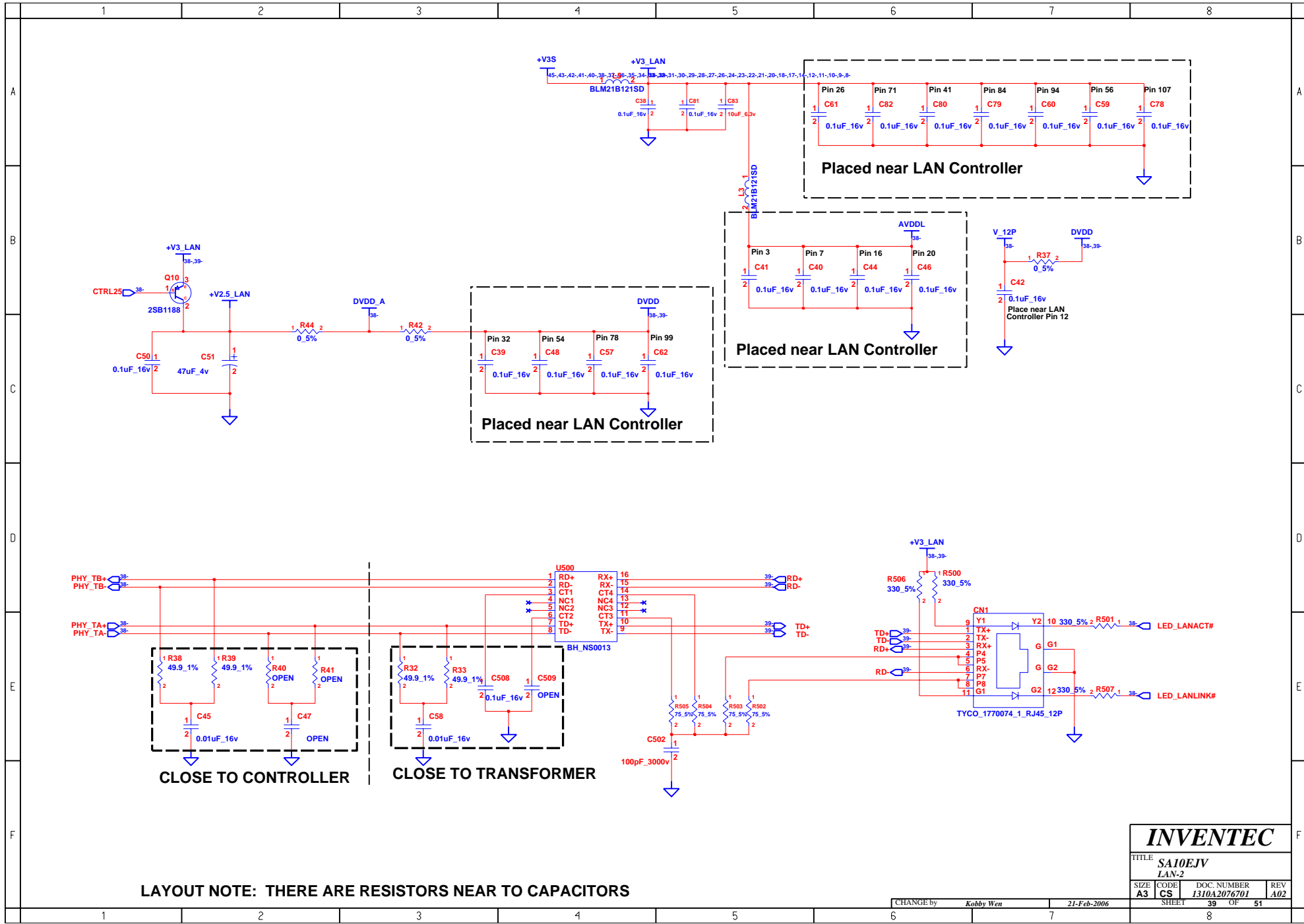

LAYOUT NOTE: THERE ARE RESISTORS NEAR TO CAPACITORS

INVENTEC

TITLE			
SAI0EJV			
LAN-2			
SIZE	CODE	DOC. NUMBER	REV
A3	CS	1310A2076701	A02

CHANGE by	Kobby Wen	21-Feb-2006	SHEET	39	OF	51
-----------	-----------	-------------	-------	----	----	----

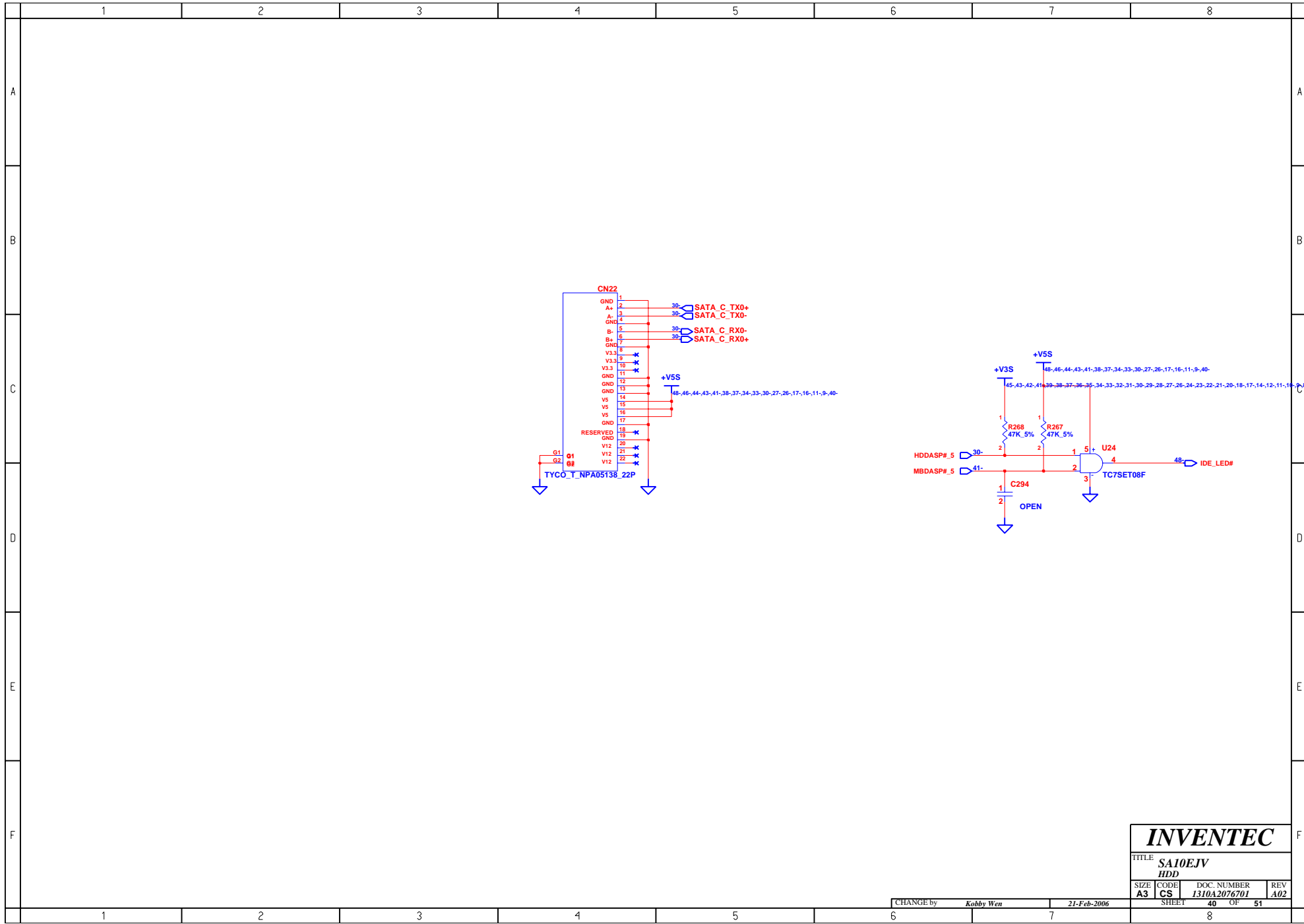

INVENTEC			
TITLE SA10EJV			
HDD			
SIZE A3	CODE CS	DOC. NUMBER 1310A2076701	REV A02
CHANGE by <i>Kobby Wen</i>		21-Feb-2006	SHEET 40 OF 51

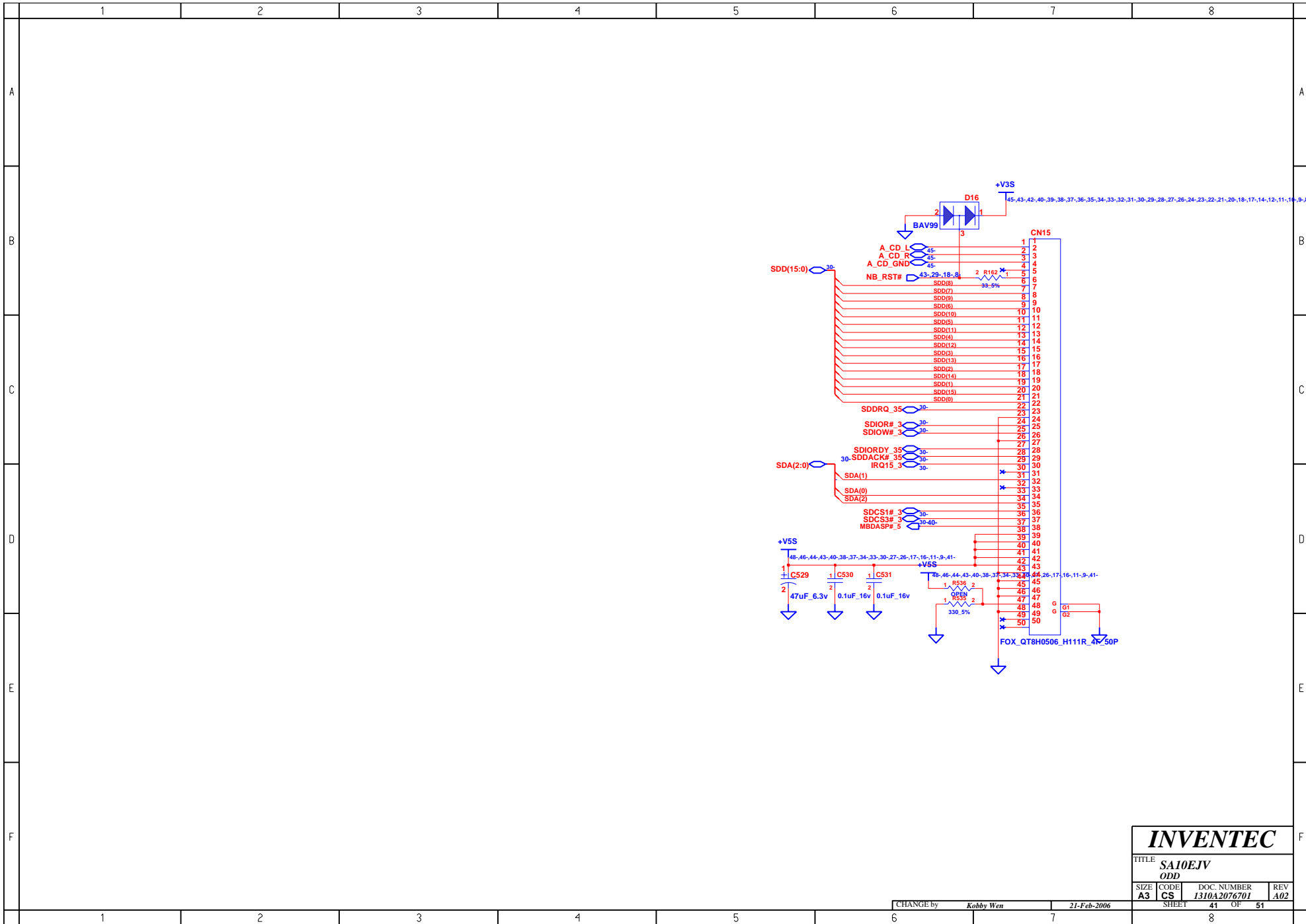

INVENTEC

TITLE			
SA10EJV			
ODD			
SIZE	CODE	DOC. NUMBER	REV
A3	CS	1310A2076701	A02

CHANGE by	Kobby Wen	21-Feb-2006	SHEET	41	OF	51
-----------	-----------	-------------	-------	----	----	----

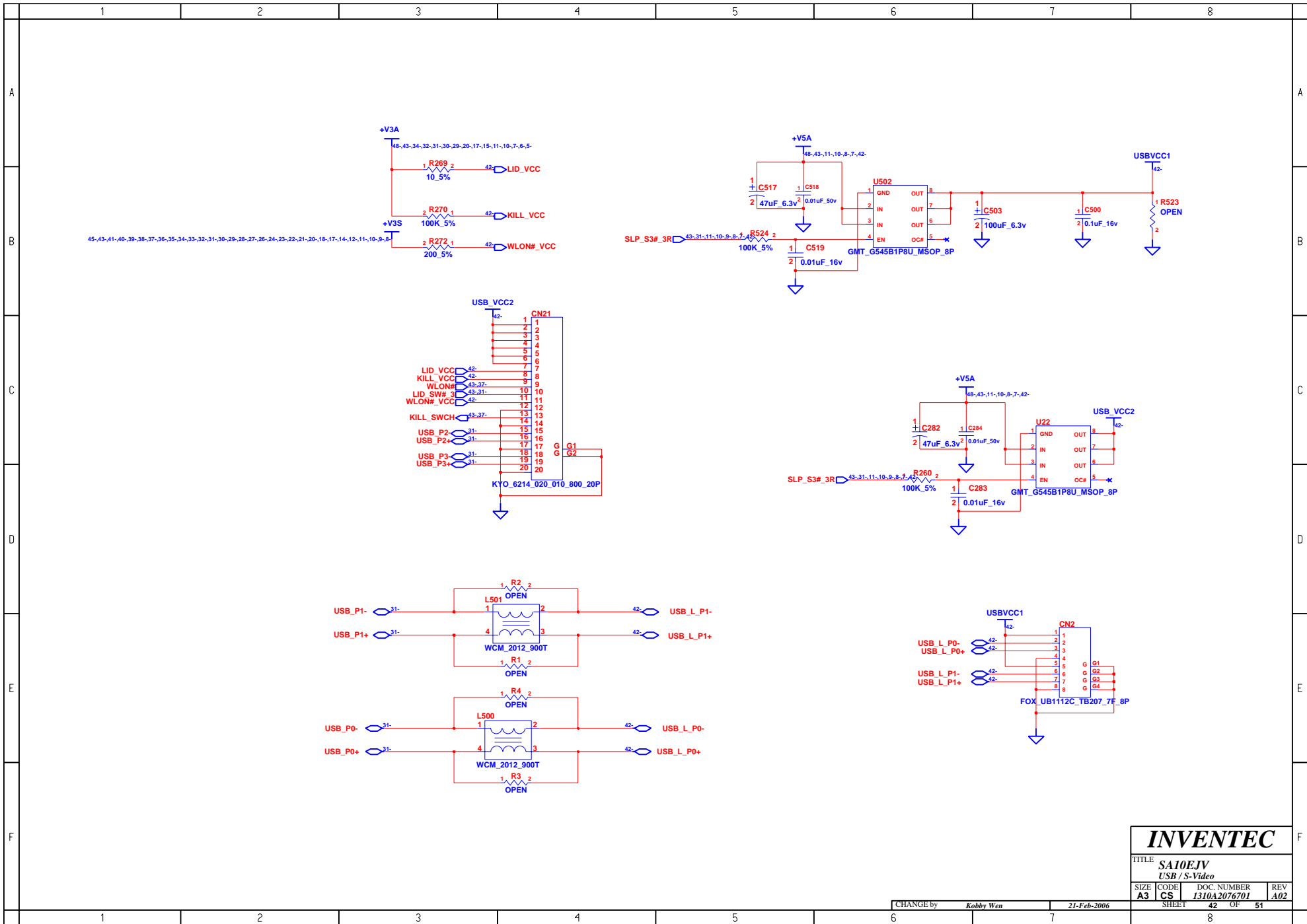

INVENTEC

TITLE
SA10EJV
USB / S-Video

SIZE A3	CODE CS	DOC. NUMBER I310A2076701	REV A02
------------	------------	-----------------------------	------------

CHANGE by *Kobby Wen* 21-Feb-2006 SHEET 42 OF 51

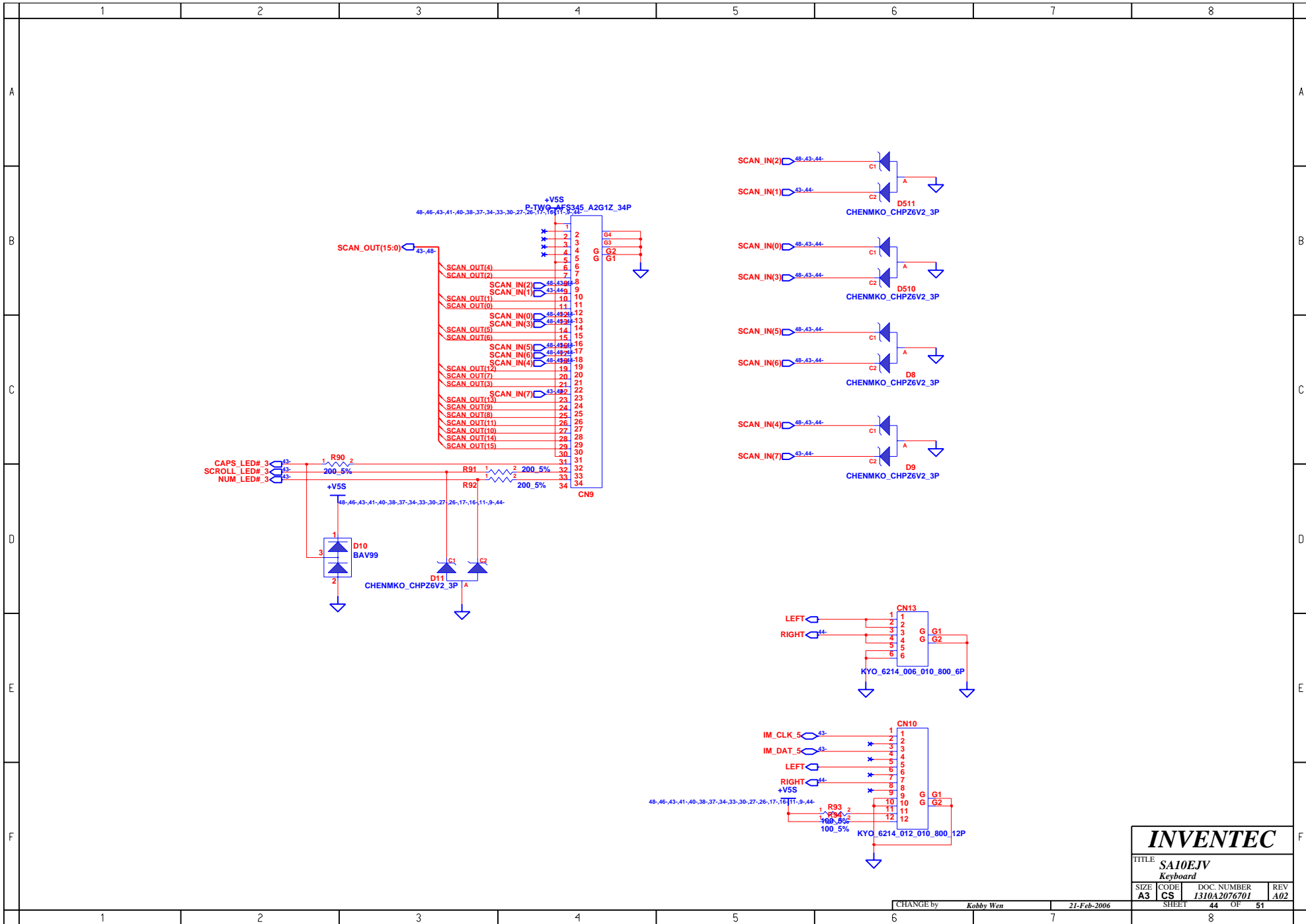

INVENTEC			
TITLE SA10EJV Keyboard			
SIZE A3	CODE CS	DOC. NUMBER 1310A2076701	REV A02
CHANGE by <i>Kobby Wen</i>		21-Feb-2006	
		SHEET 44 OF 51	

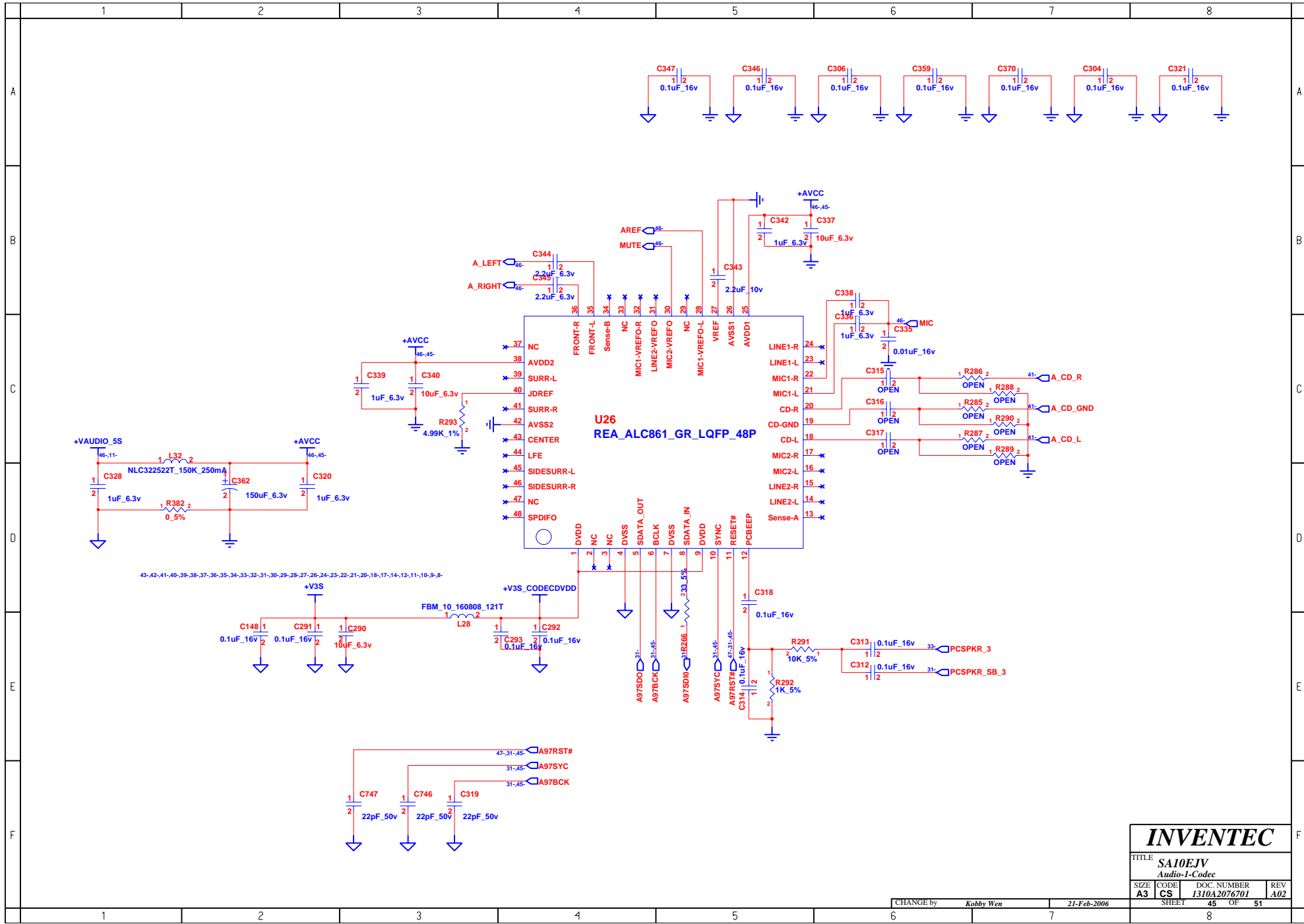

INVENTEC			
TITLE SA10EJV Audio-1-Codec			
SIZE A3	CODE CS	DOC. NUMBER I310A2076701	REV A02
CHANGE by <i>Kobby Wen</i>		21-Feb-2006	
SHEET		45 OF 51	

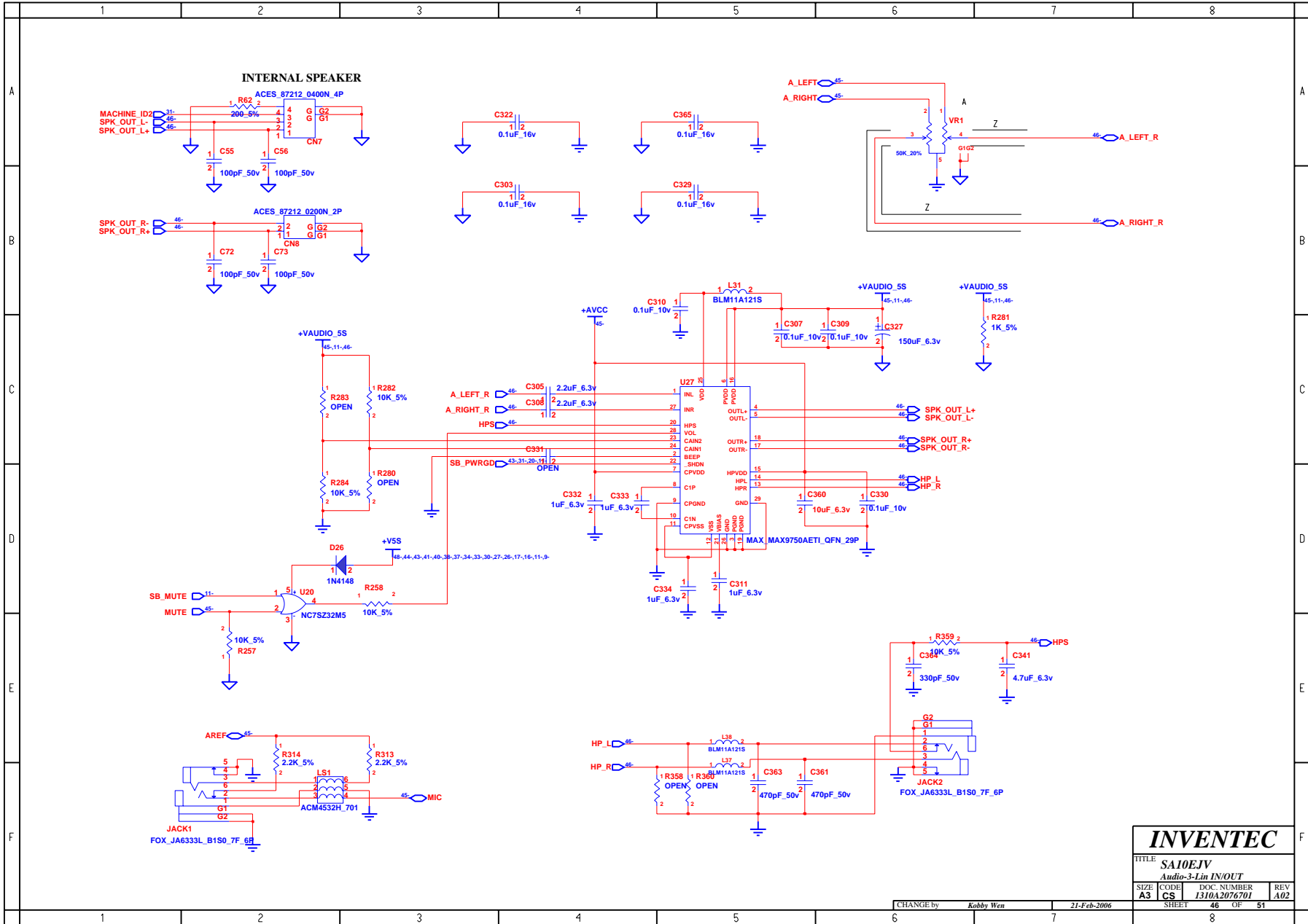

INVENTEC

TITLE: **SA10EJV**
Audio-3-Lin IN/OUT

SIZE	CODE	DOC. NUMBER	REV
A3	CS	1310A2076701	A02

CHANGE by: *Kobby Wen* 21-Feb-2006 SHEET 46 OF 51

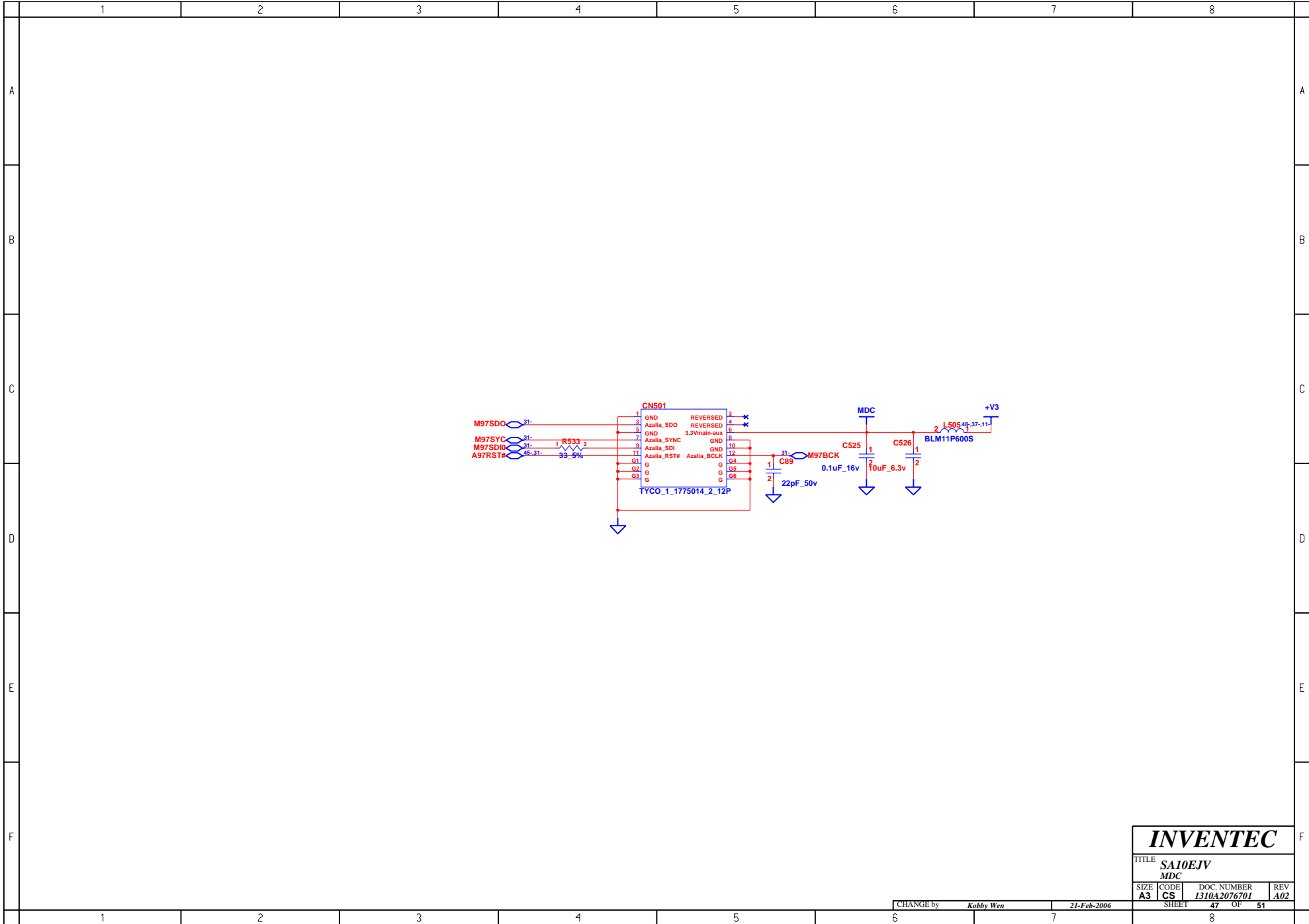

INVENTEC

TITLE **SA10EJV**
MDC

SIZE A3	CODE CS	DOC. NUMBER 1310A2076701	REV A02
-------------------	-------------------	------------------------------------	-------------------

CHANGE by *Kobby Wen* 21-Feb-2006

SHEET 47 OF 51

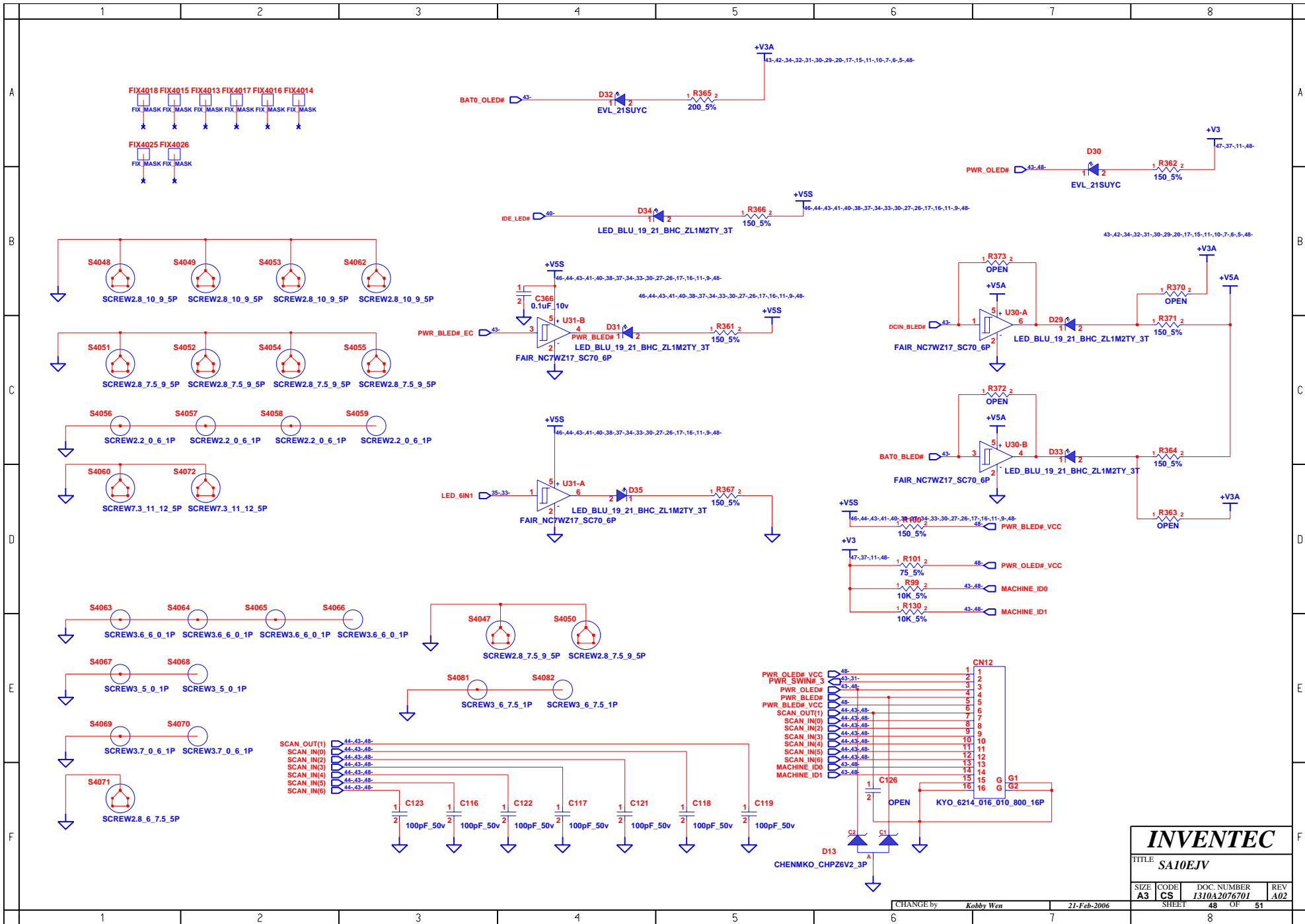

INVENTEC			
TITLE SA10EJV			
SIZE A3	CODE CS	DOC. NUMBER 1310A2076701	REV A02
CHANGE by <i>Kobby Wen</i>		21-Feb-2006	
SHEET 48		OF 51	

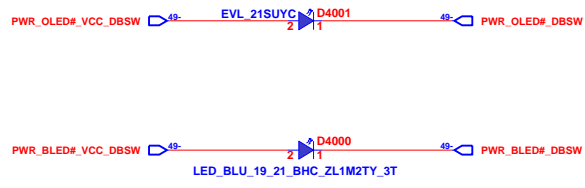

LED & SWITCH

POWER SWITCH

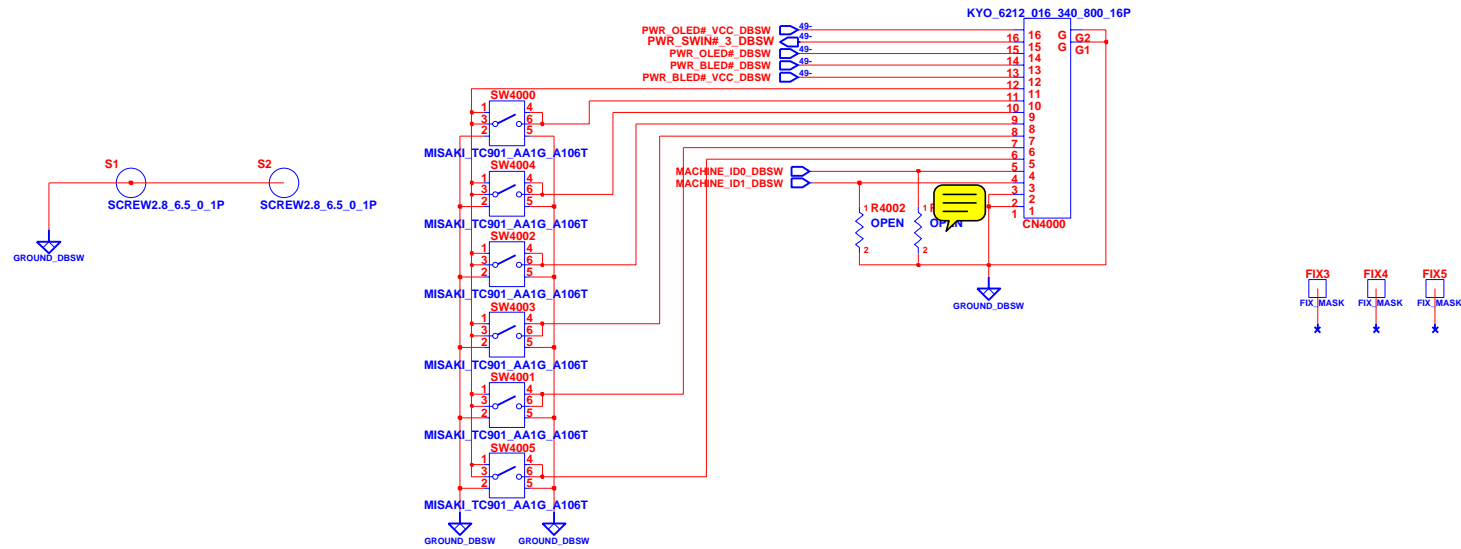

INVENTEC			
TITLE <i>San Antonio 10EJV</i>			
Buttom Board			
SIZE A3	CODE CS	DOC. NUMBER	REV
CHANGE by SA10E		21-Feb-2006	SHEET 49 OF 51
1		2	8

KILL SWITCH

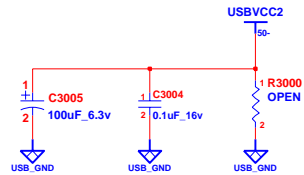
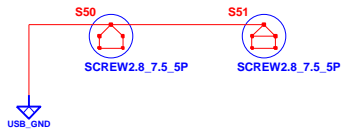
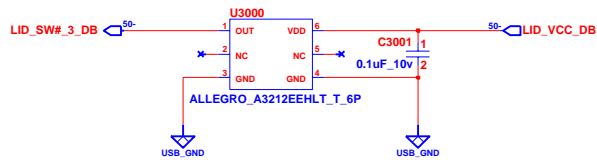
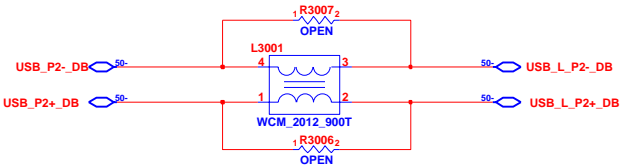
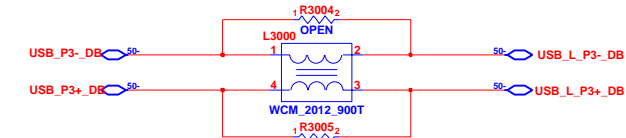
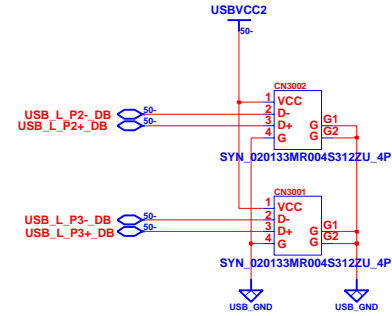
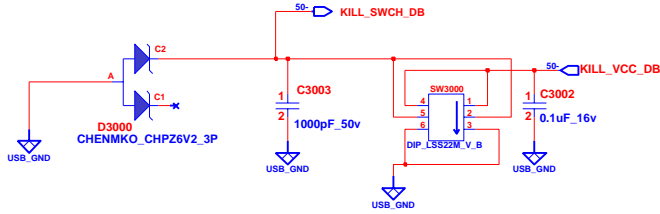
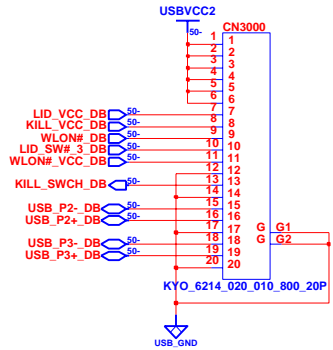

INVENTEC

TITLE			
SA10EJV			
USB/1394/SVIDEO Board			
SIZE	CODE	DOC. NUMBER	REV
A3	CS	1310A2076701	A02

CHANGE by *Kobby Wen* 21-Feb-2006

SHEET 50 OF 51

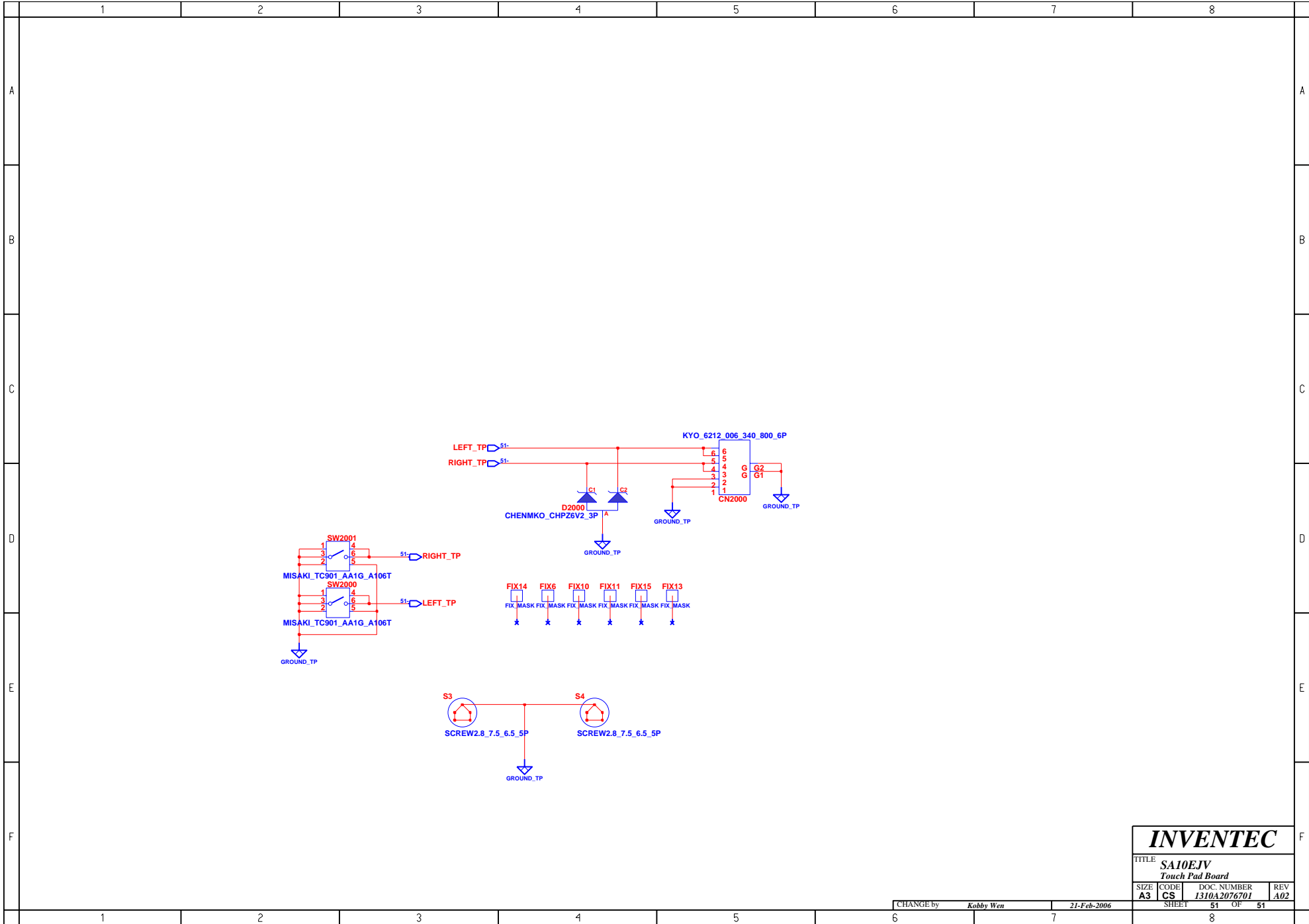

INVENTEC

TITLE **SA10EJV**
Touch Pad Board

SIZE	CODE	DOC. NUMBER	REV
A3	CS	1310A2076701	A02

CHANGE by *Kobby Wen* 21-Feb-2006

SHEET 51 OF 51