

ZI6 BLOCK DIAGRAM

CENTRINO

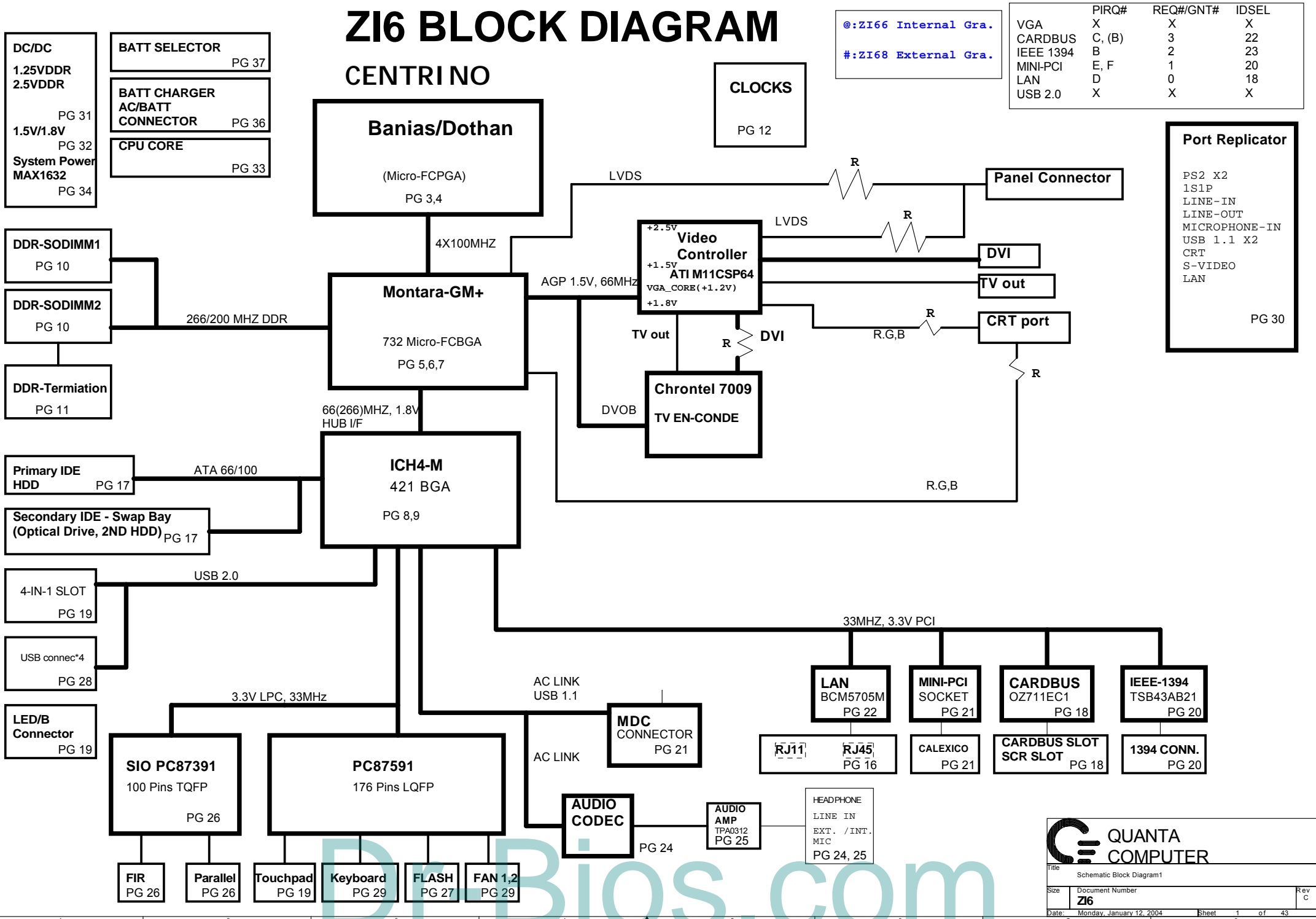

@:ZI66 Internal Gra.
#:ZI68 External Gra.

	PIRQ#	REQ#/GNT#	IDSEL
VGA	X	X	X
CARDBUS	C, (B)	3	22
IEEE 1394	B	2	23
MINI-PCI	E, F	1	20
LAN	D	0	18
USB 2.0	X	X	X

Port Replicator	
PS2	X2
1S1P	
LINE-IN	
LINE-OUT	
MICROPHONE-IN	
USB 1.1	X2
CRT	
S-VIDEO	
LAN	

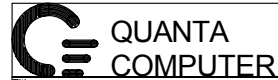

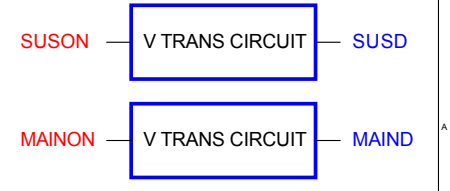
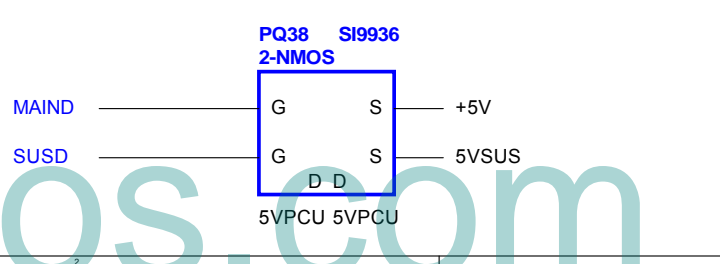
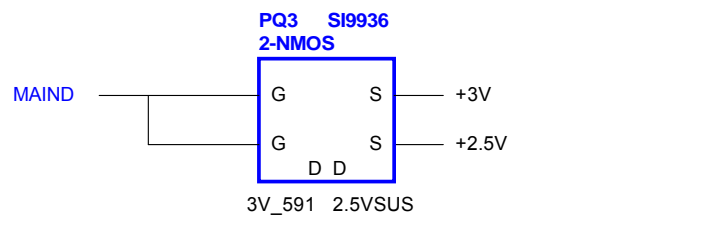
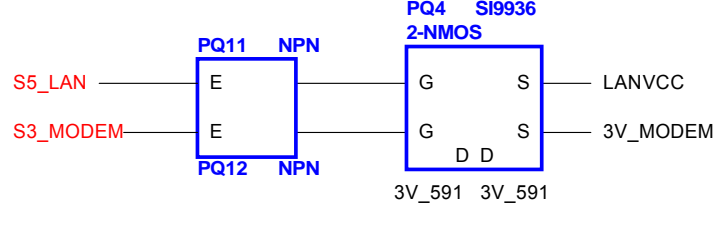
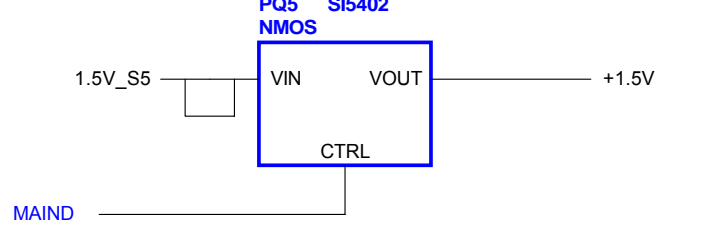
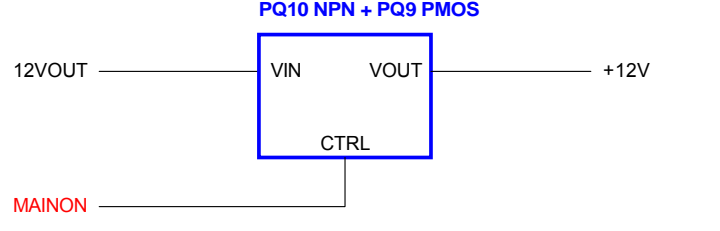
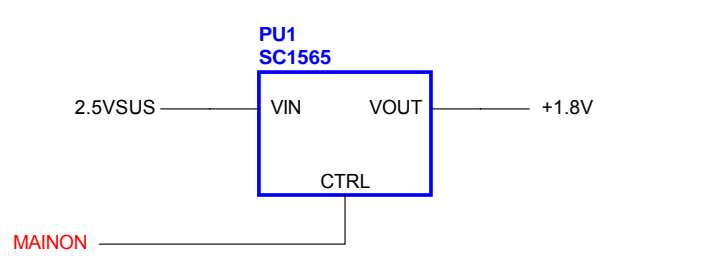
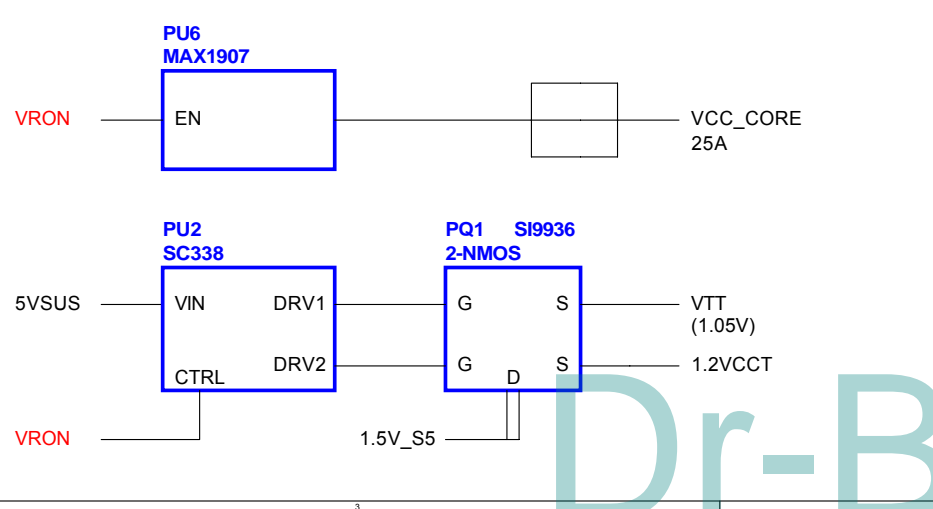
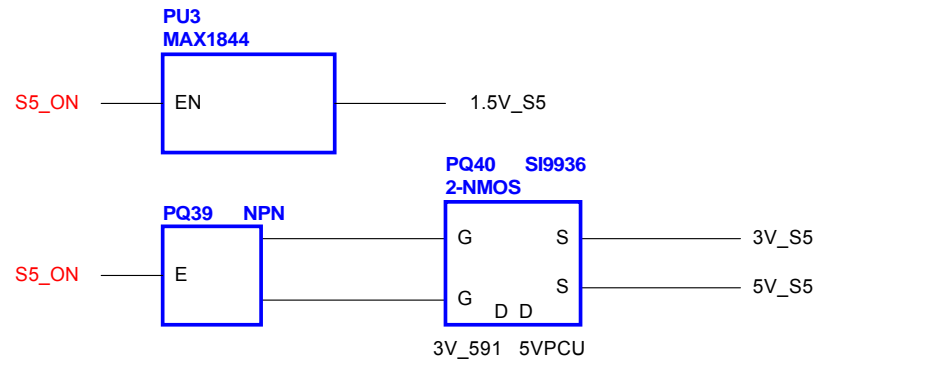
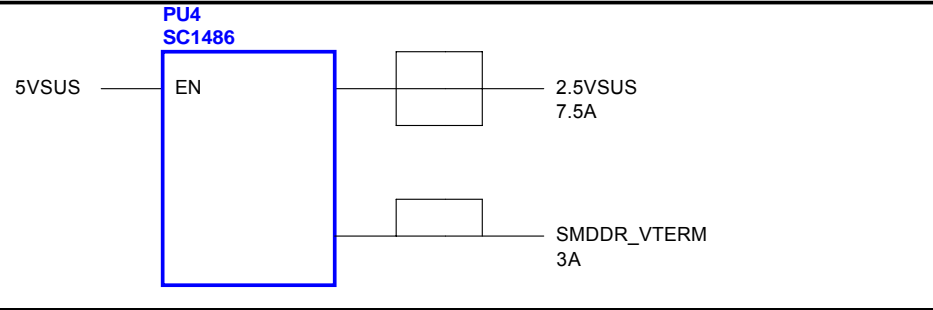
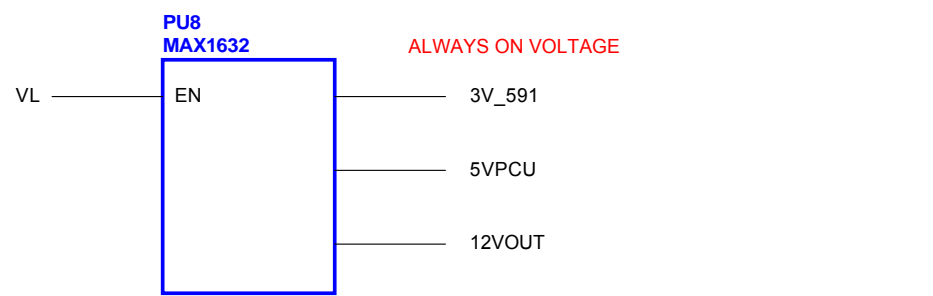

Dr-Bios.com

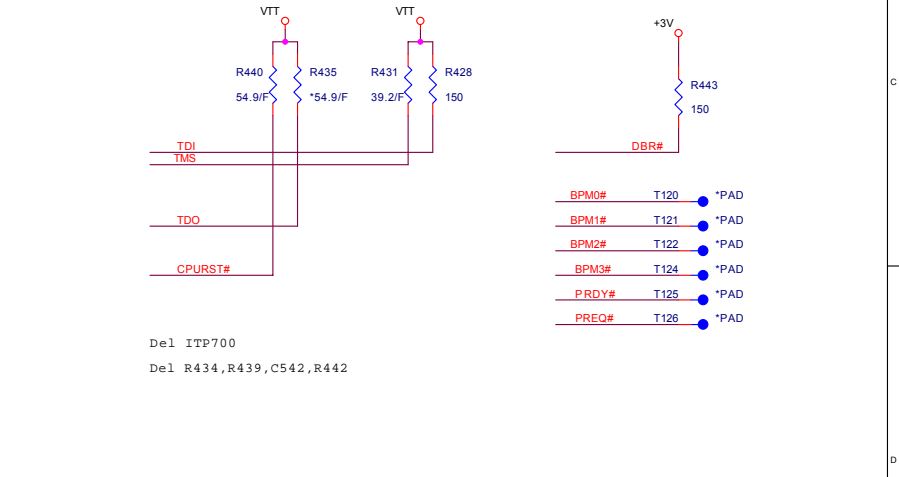
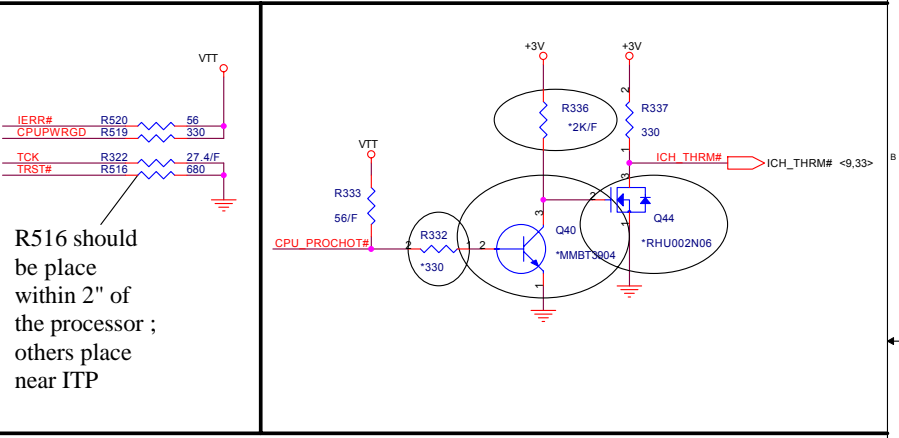
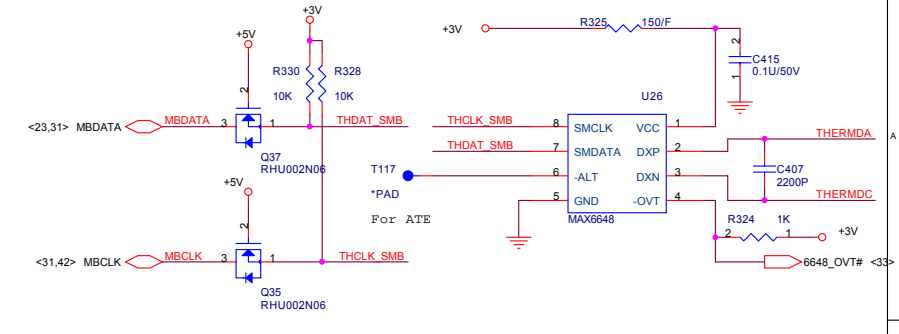
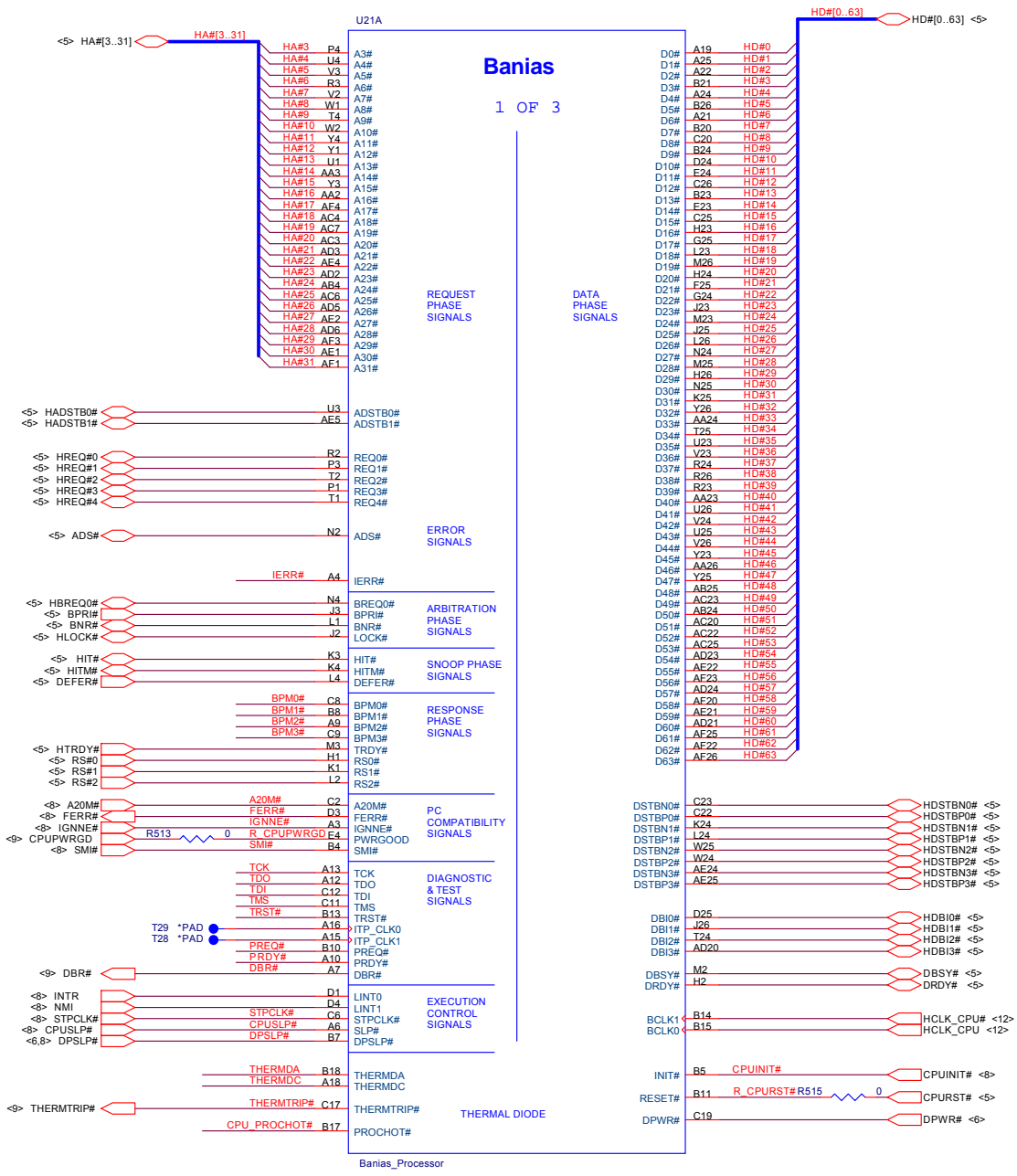

Dr-Bios.com

These 4 Resistors need to place with 0.5" of CPU.
 Comp0,2 trace need to be zo=27.4 ohm,
 comp1,3 traces need to be zo=55 ohm.

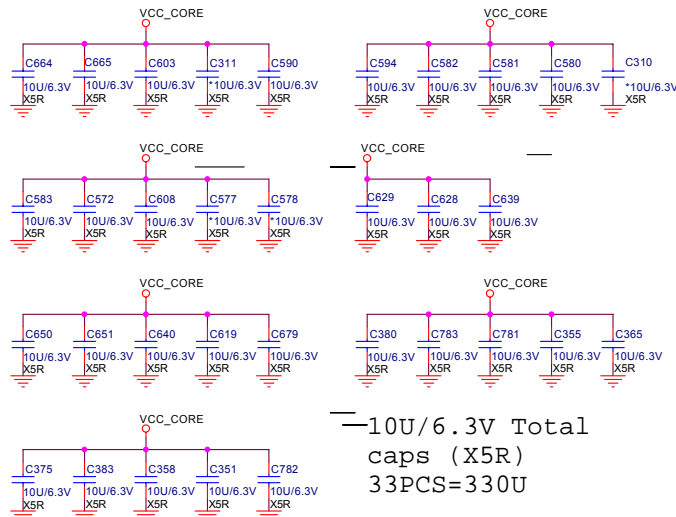
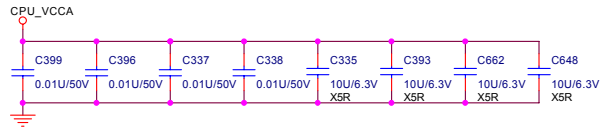
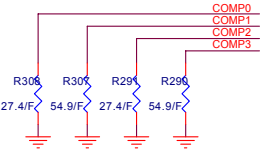

—10U/6.3V Total caps (X5R)
 33PCS=330U

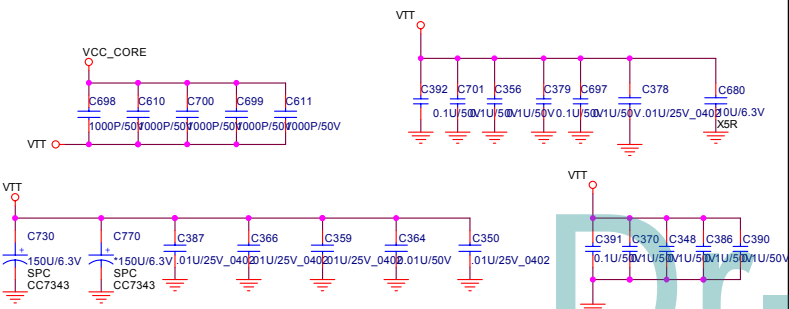

GTLREF: 2/3 VCCP+-2% 25 MILS (>50 MILS PREFERRED) SPACE
 T < 0.5" 25 mils space T < 0.5"

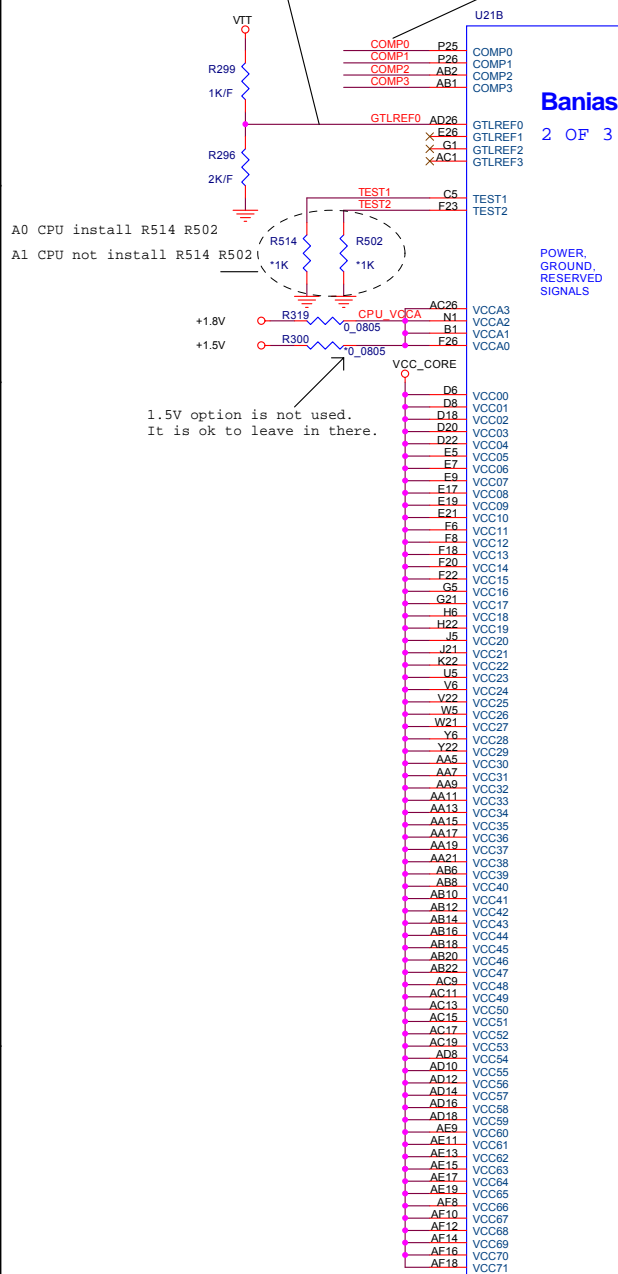

A0 CPU install R514 R502

A1 CPU not install R514 R502

1.5V option is not used.
 It is ok to leave in there.

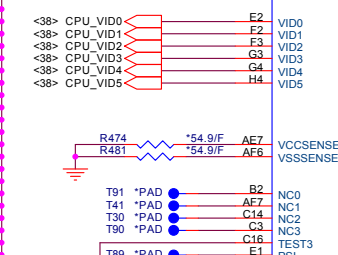
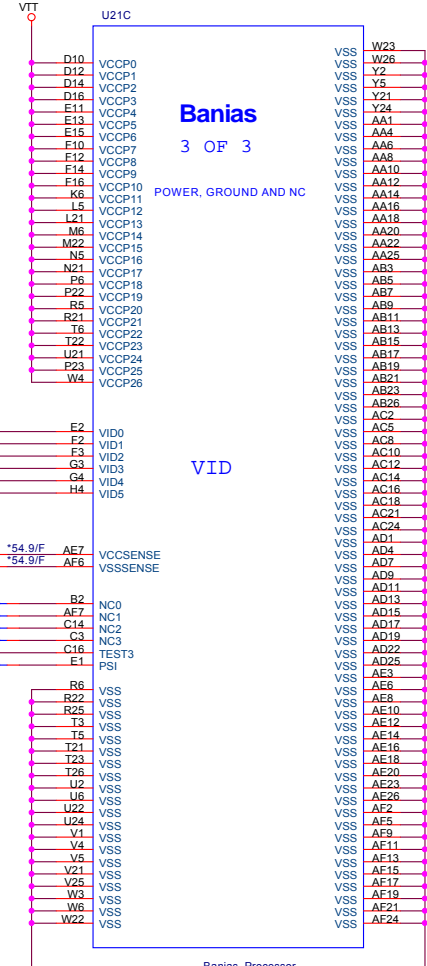

* VCC,BOOT 1.2V
 VCC_CORE 1.468V
 (DEEPER SLEEP) 0.956V
 VTT 1.05V
 VCCA 1.8V



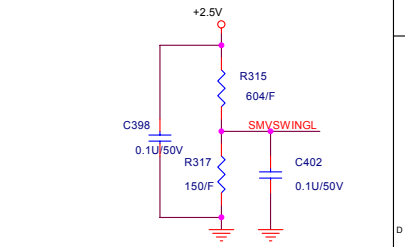
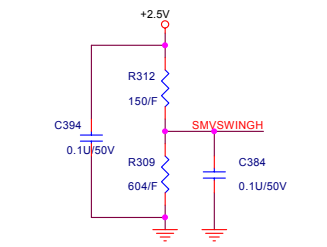
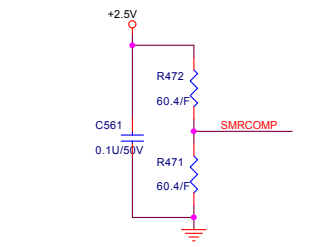
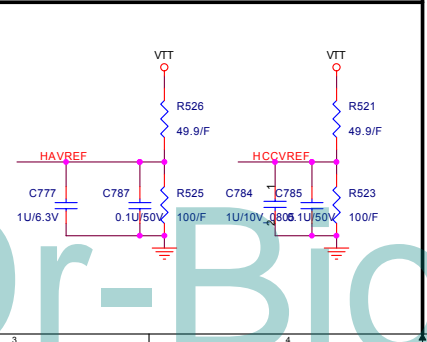
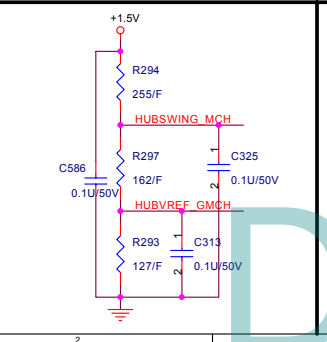
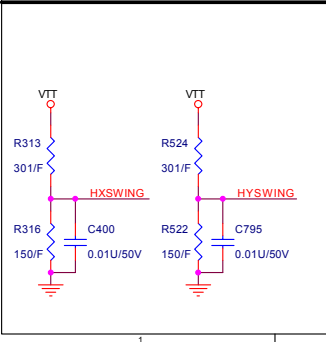
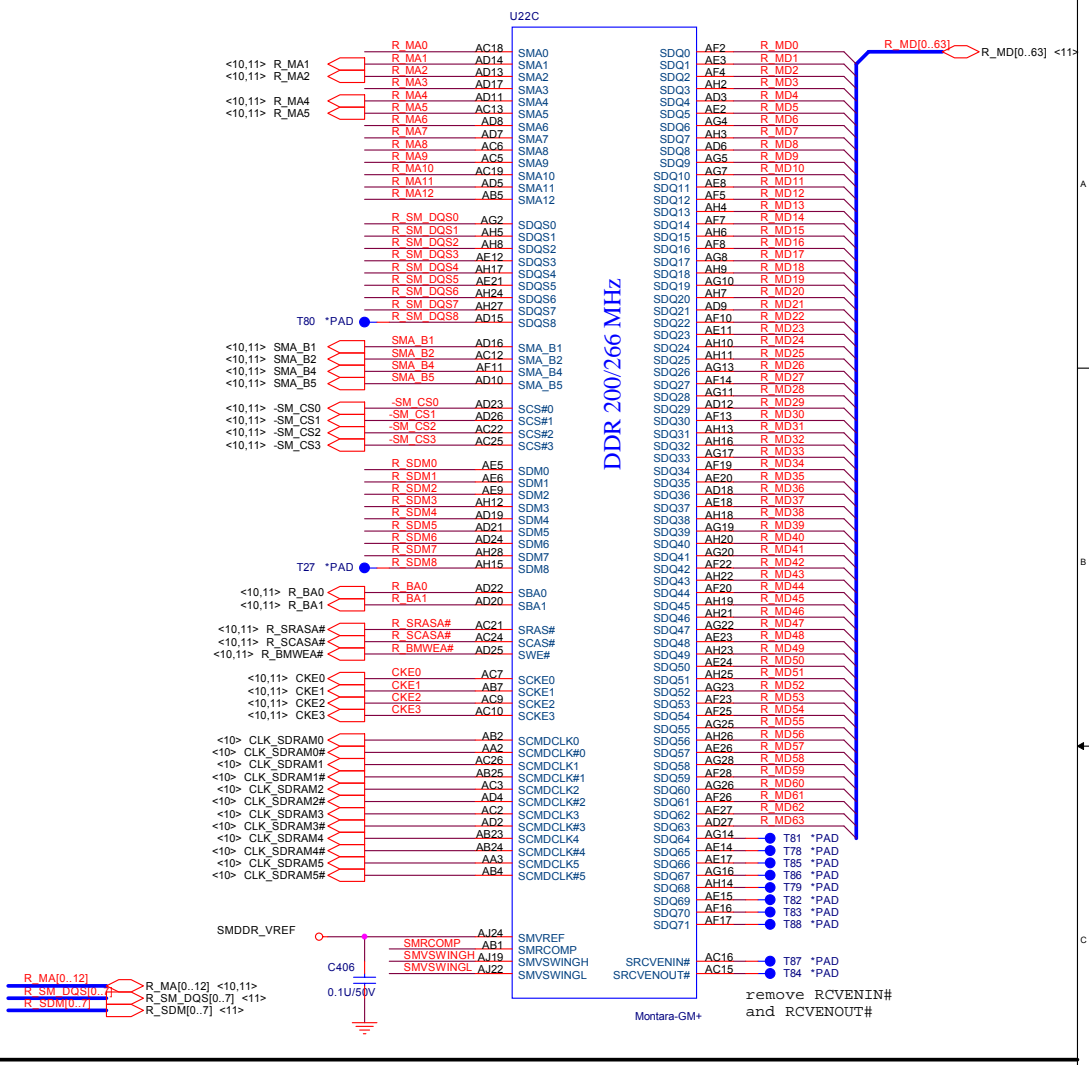
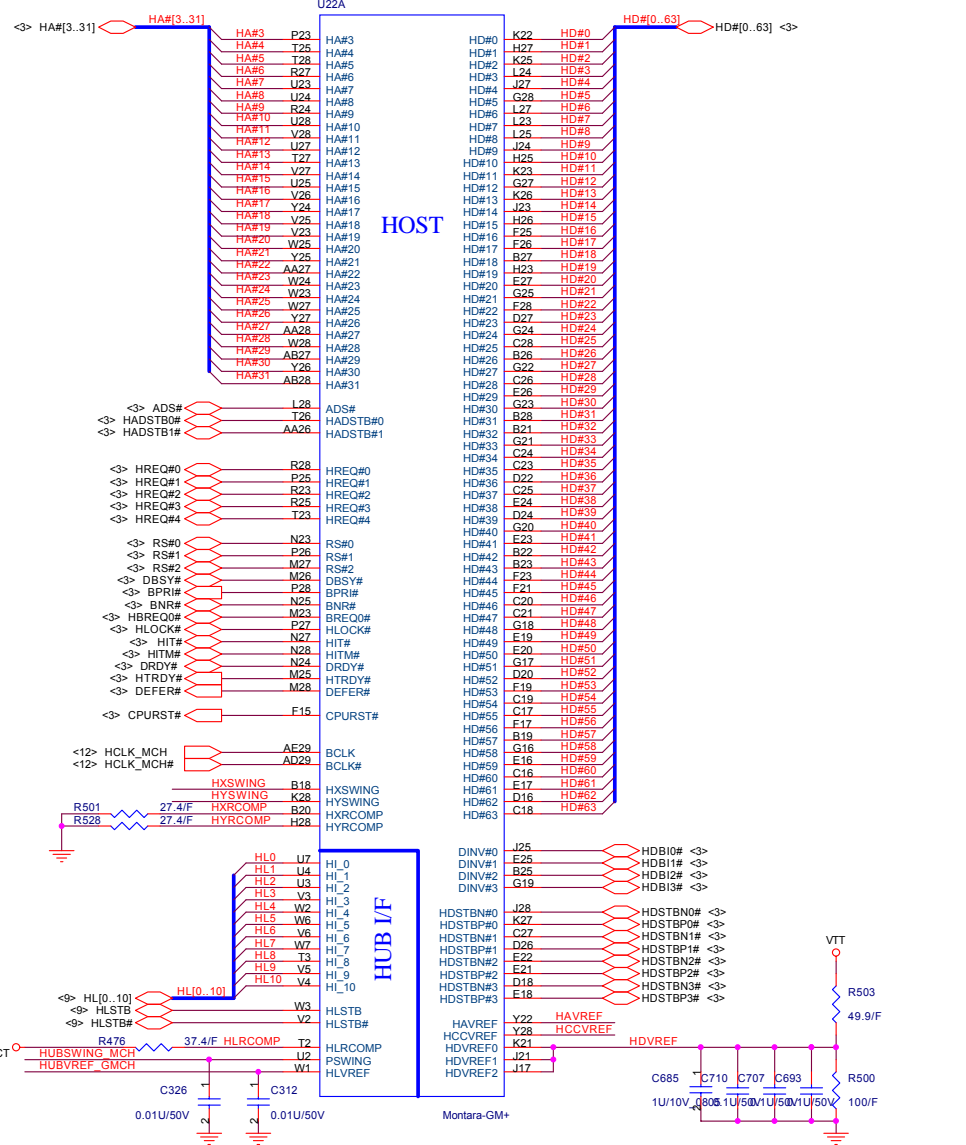

QUANTA COMPUTER

Title: Montara - GM+ (HOST & DDR)

Size: Document Number
Z16

Date: Monday, January 12, 2004 Sheet 5 of 43 Rev C

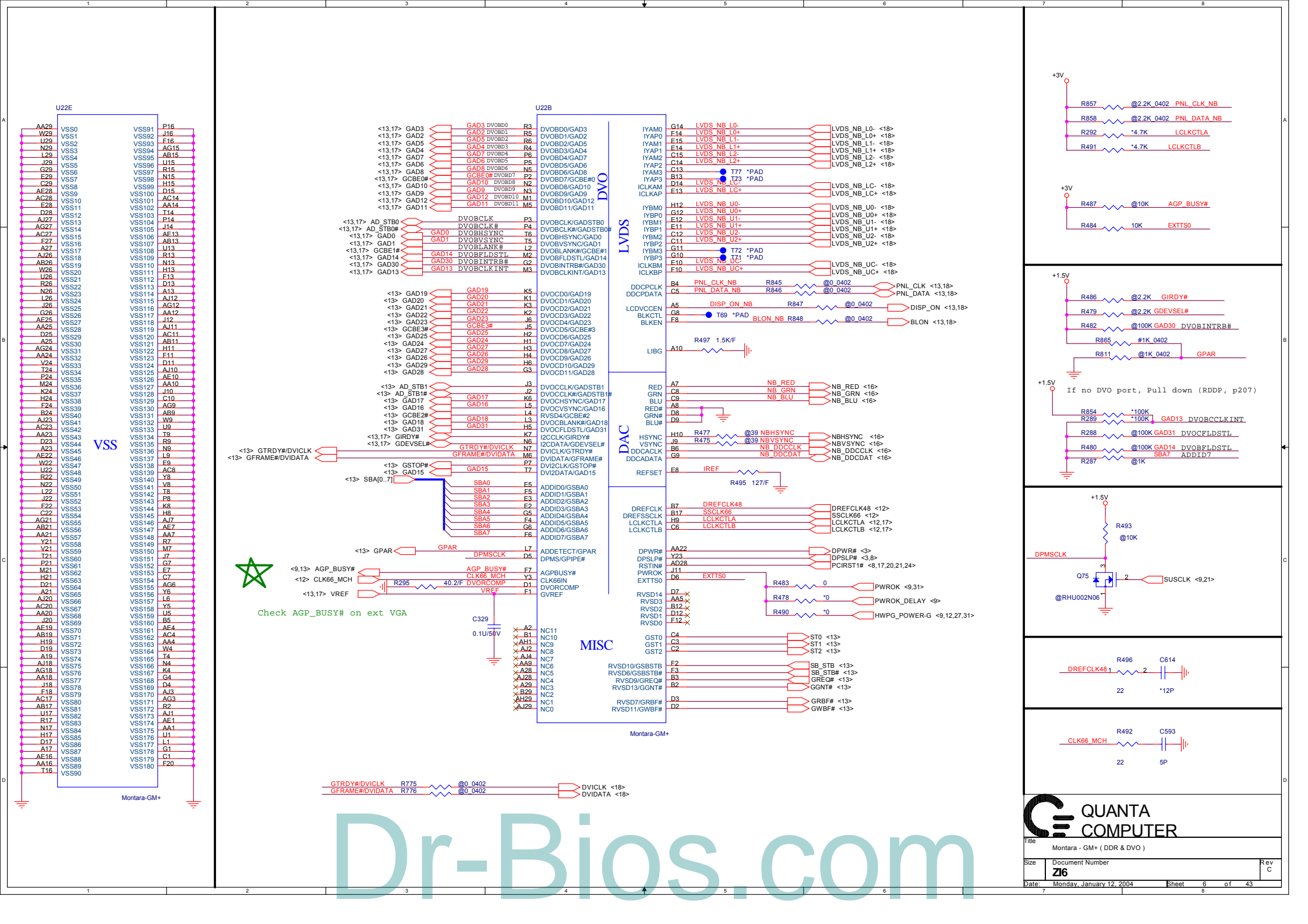

U22E

AA29	VSS0	VSS91	P16
W29	VSS1	VSS92	J16
U29	VSS2	VSS93	AC15
V29	VSS3	VSS94	AB15
Y29	VSS4	VSS95	U15
Z29	VSS5	VSS96	R15
AA29	VSS6	VSS97	N15
AB29	VSS7	VSS98	H15
AC29	VSS8	VSS99	D15
AD29	VSS9	VSS100	AC14
AE29	VSS10	VSS101	AD14
AF29	VSS11	VSS102	AE14
AG29	VSS12	VSS103	T14
AH29	VSS13	VSS104	P14
AI29	VSS14	VSS105	AE13
AJ29	VSS15	VSS106	AB13
AK29	VSS16	VSS107	U13
AL29	VSS17	VSS108	R13
AM29	VSS18	VSS109	N13
AN29	VSS19	VSS110	H13
AO29	VSS20	VSS111	D13
AP29	VSS21	VSS112	A13
AQ29	VSS22	VSS113	J13
AR29	VSS23	VSS114	AC12
AS29	VSS24	VSS115	AB12
AT29	VSS25	VSS116	U12
AV29	VSS26	VSS117	R12
AW29	VSS27	VSS118	N12
AX29	VSS28	VSS119	H12
AY29	VSS29	VSS120	D12
AZ29	VSS30	VSS121	A12
BA29	VSS31	VSS122	J12
BB29	VSS32	VSS123	AC11
BC29	VSS33	VSS124	AB11
BD29	VSS34	VSS125	U11
BE29	VSS35	VSS126	R11
BF29	VSS36	VSS127	N11
BG29	VSS37	VSS128	H11
BH29	VSS38	VSS129	D11
BI29	VSS39	VSS130	A11
BJ29	VSS40	VSS131	J11
BK29	VSS41	VSS132	AC10
BL29	VSS42	VSS133	AB10
BM29	VSS43	VSS134	U10
BN29	VSS44	VSS135	R10
BO29	VSS45	VSS136	N10
BP29	VSS46	VSS137	H10
BQ29	VSS47	VSS138	D10
BR29	VSS48	VSS139	A10
BS29	VSS49	VSS140	J10
BT29	VSS50	VSS141	AC9
BU29	VSS51	VSS142	AB9
BV29	VSS52	VSS143	U9
BW29	VSS53	VSS144	R9
BX29	VSS54	VSS145	N9
BY29	VSS55	VSS146	H9
BZ29	VSS56	VSS147	D9
CA29	VSS57	VSS148	A9
CB29	VSS58	VSS149	J9
CC29	VSS59	VSS150	AC8
CD29	VSS60	VSS151	AB8
CE29	VSS61	VSS152	U8
CF29	VSS62	VSS153	R8
CG29	VSS63	VSS154	N8
CH29	VSS64	VSS155	H8
CI29	VSS65	VSS156	D8
CJ29	VSS66	VSS157	A8
CK29	VSS67	VSS158	J8
CL29	VSS68	VSS159	AC7
CM29	VSS69	VSS160	AB7
CN29	VSS70	VSS161	U7
CO29	VSS71	VSS162	R7
CP29	VSS72	VSS163	N7
CQ29	VSS73	VSS164	H7
CR29	VSS74	VSS165	D7
CS29	VSS75	VSS166	A7
CT29	VSS76	VSS167	J7
CU29	VSS77	VSS168	AC6
CV29	VSS78	VSS169	AB6
CW29	VSS79	VSS170	U6
CX29	VSS80	VSS171	R6
CY29	VSS81	VSS172	N6
CZ29	VSS82	VSS173	H6
DA29	VSS83	VSS174	D6
DB29	VSS84	VSS175	A6
DC29	VSS85	VSS176	J6
DD29	VSS86	VSS177	AC5
DE29	VSS87	VSS178	AB5
DF29	VSS88	VSS179	U5
DG29	VSS89	VSS180	R5
DH29	VSS90	VSS180	N5

U22B

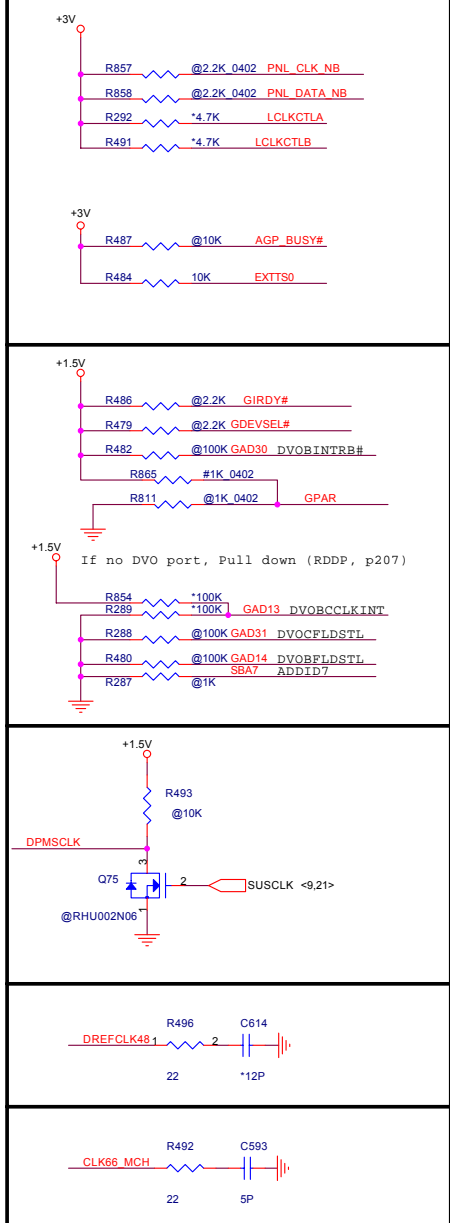
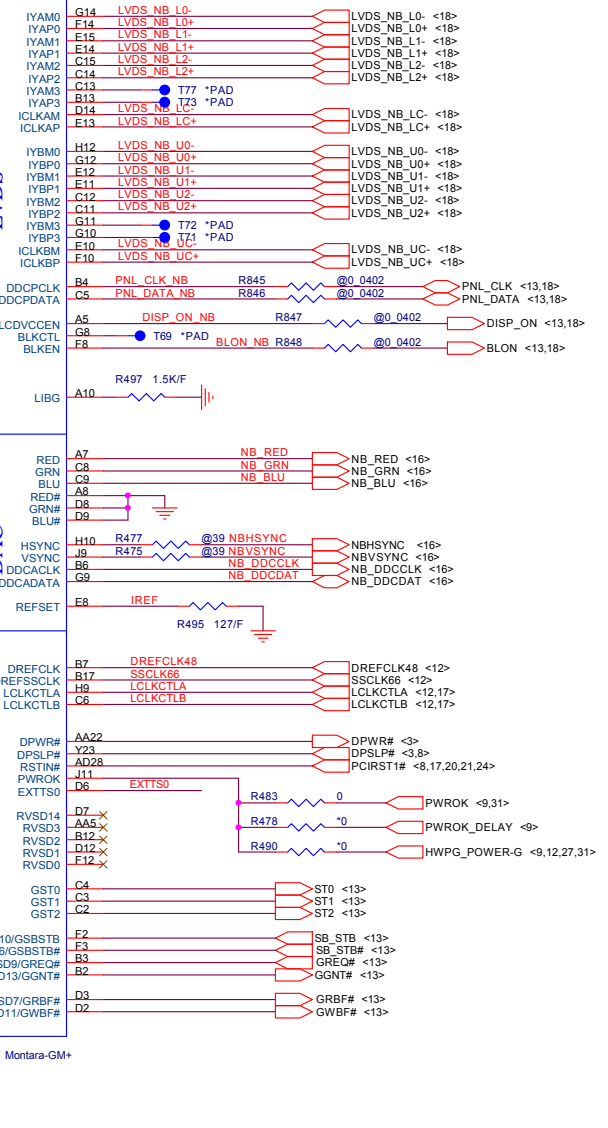
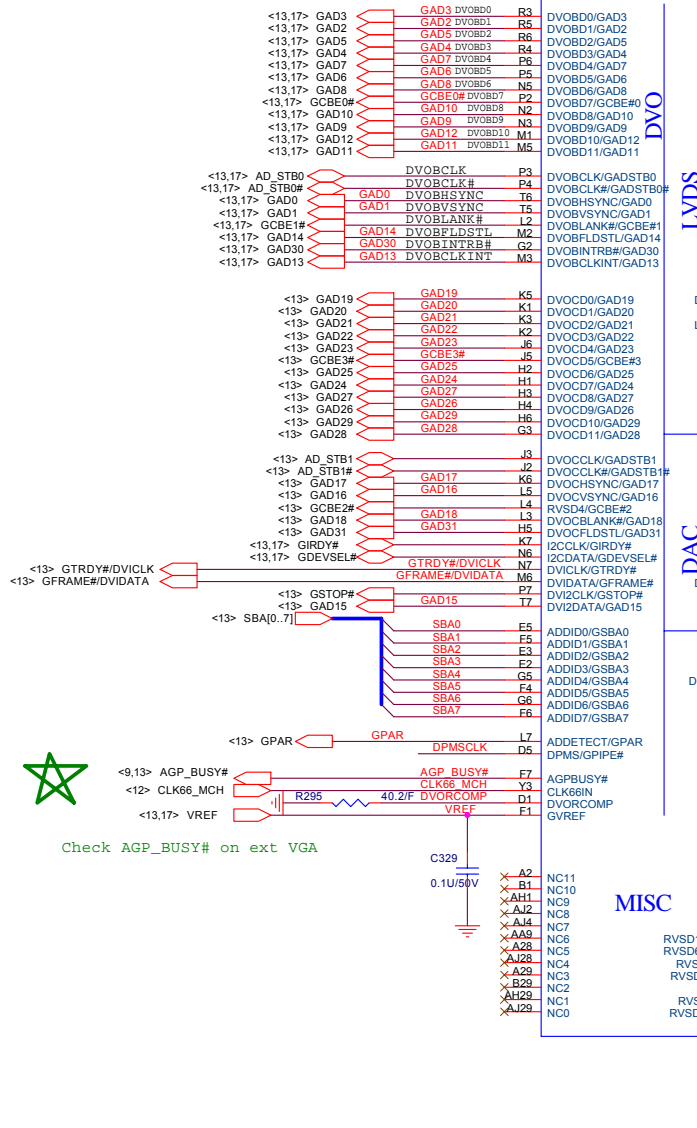

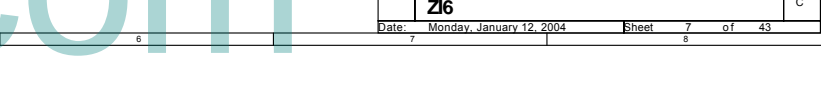
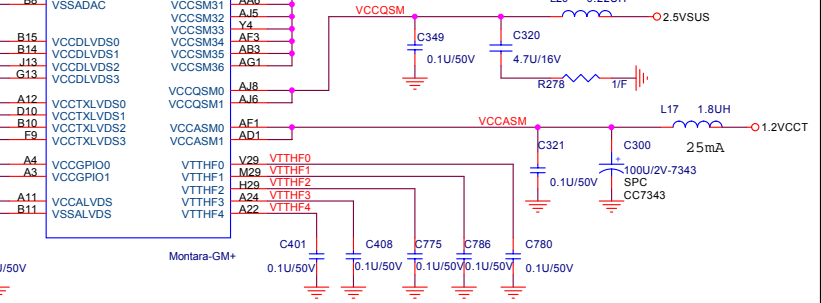
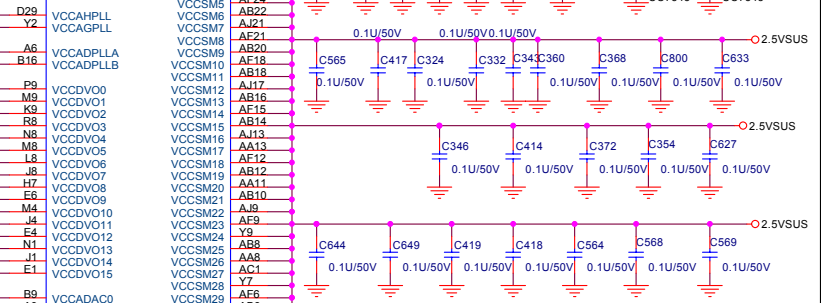
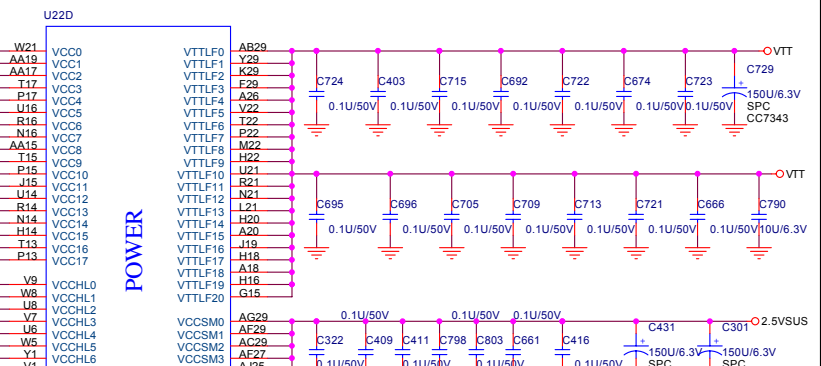
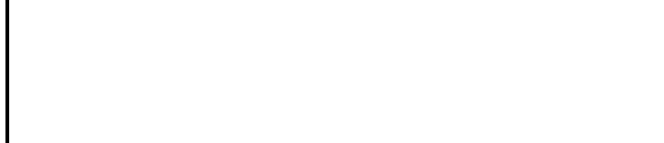
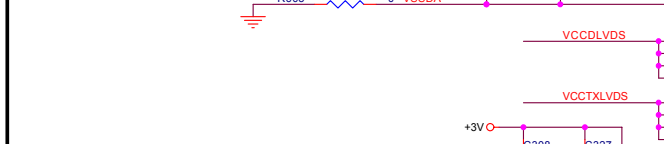
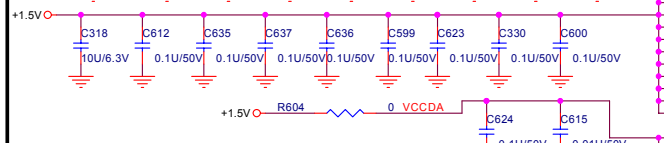
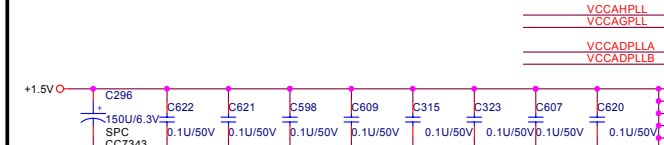
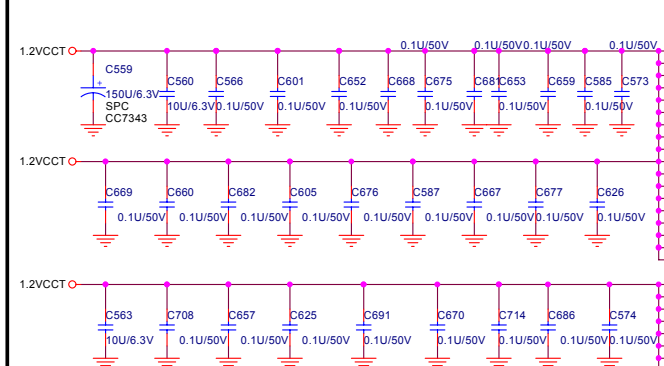
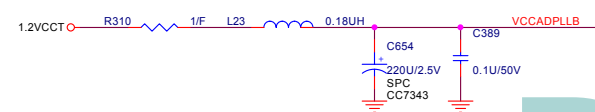
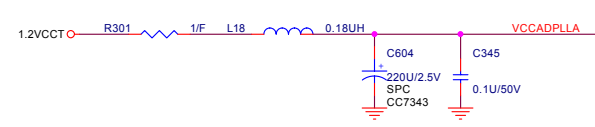
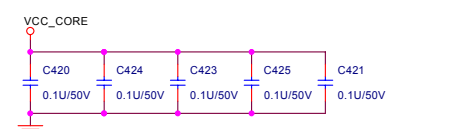
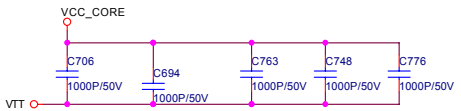
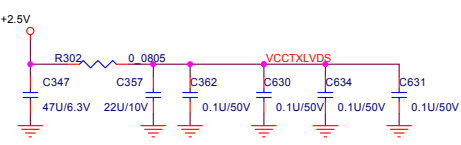
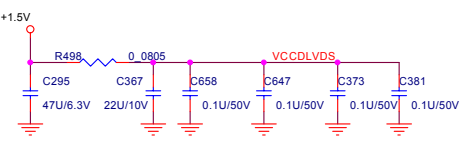
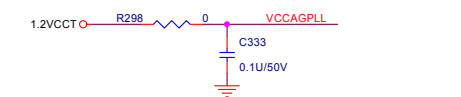
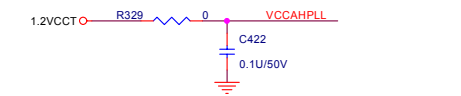

POWER

Dr-Bios.com

QUANTA COMPUTER

Title: Montara - GM+ (POWER)

Size: Document Number **Z16**

Date: Monday, January 12, 2004 Sheet 7 of 43

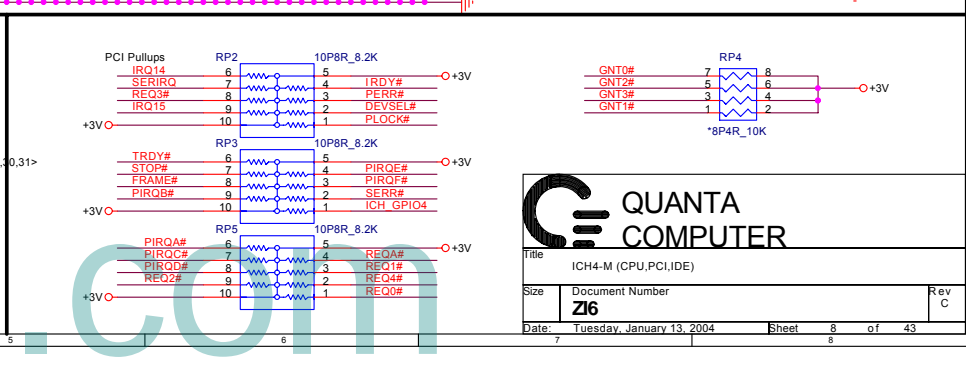
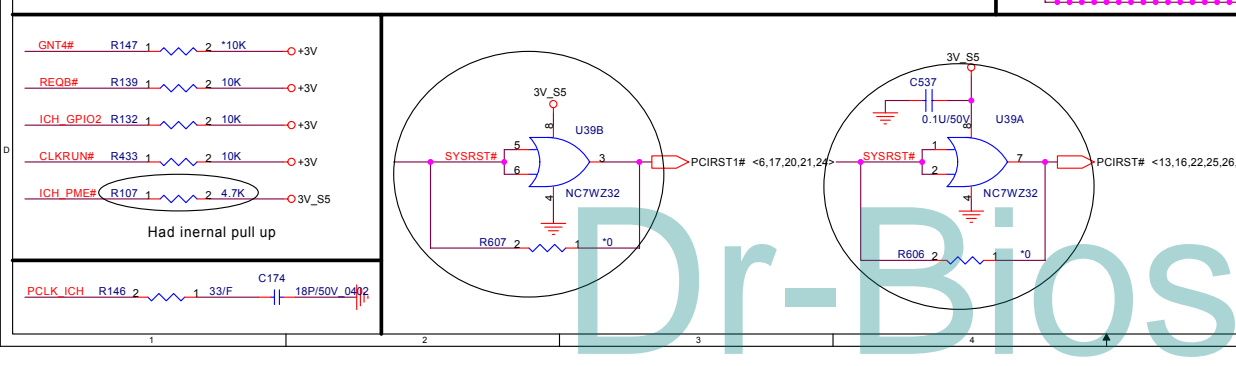
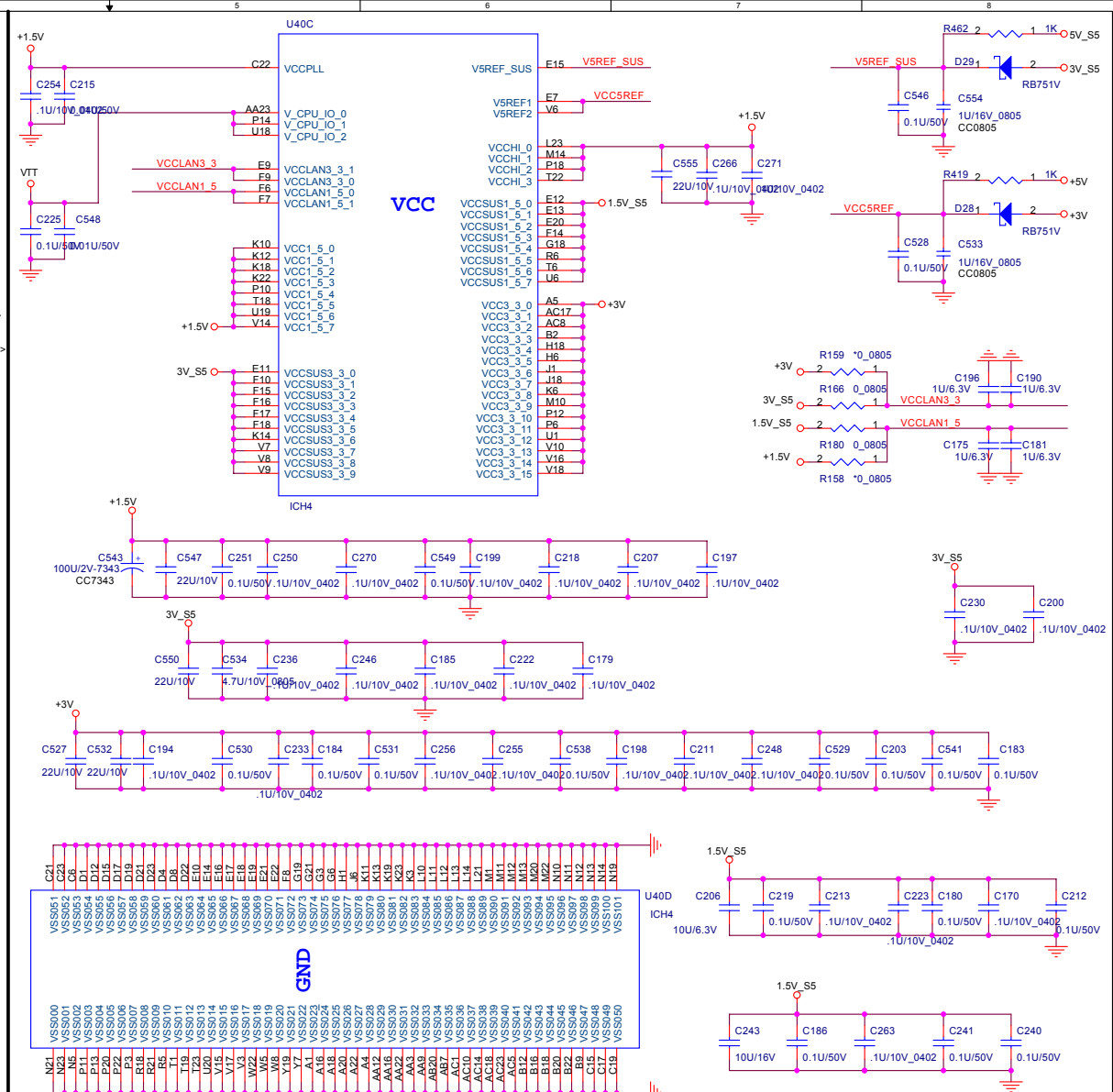
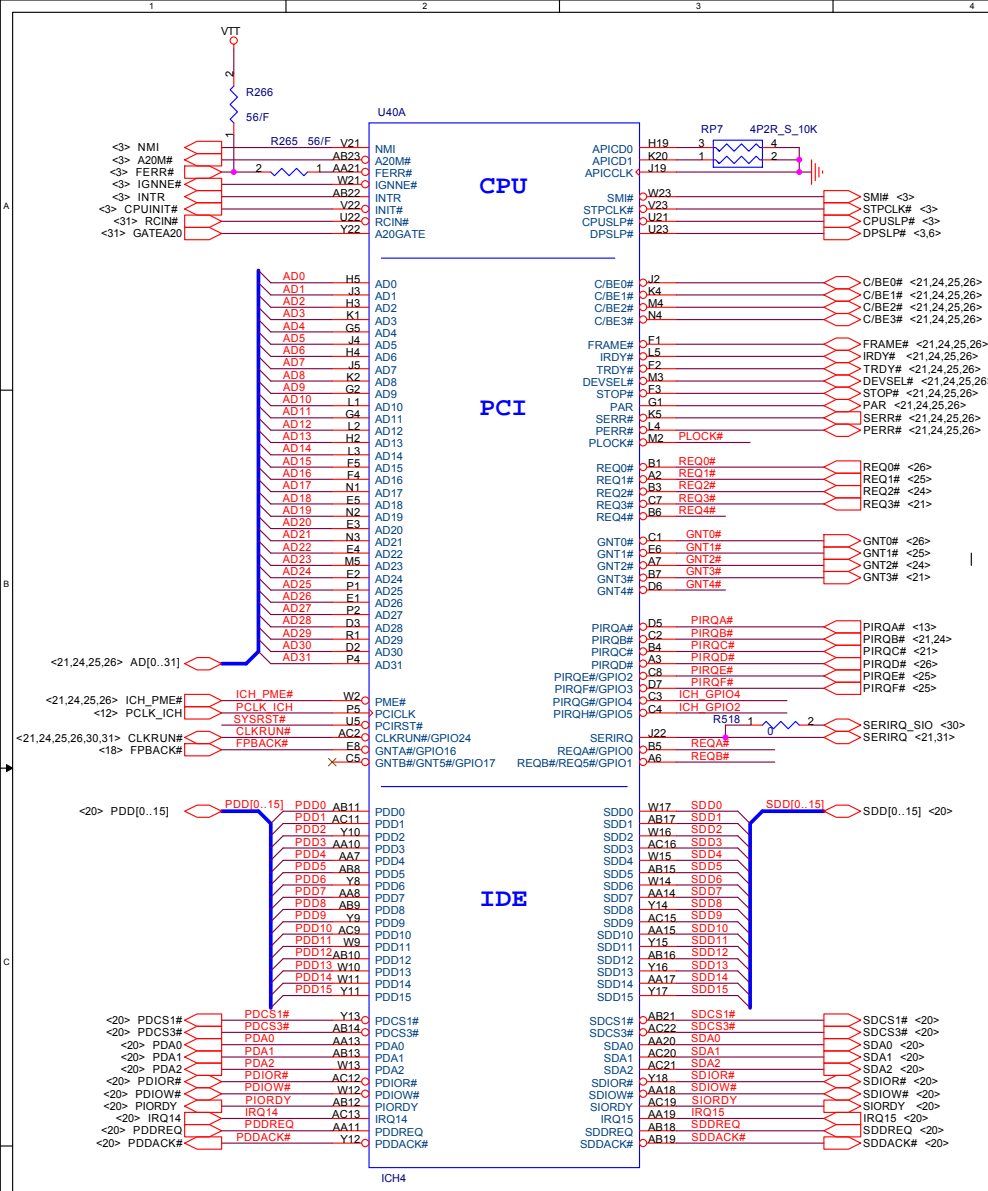

QUANTA COMPUTER

Title: ICH4-M (CPU,PCI,IDE)

Size: Document Number **Z16**

Date: Tuesday, January 13, 2004 Sheet 8 of 43

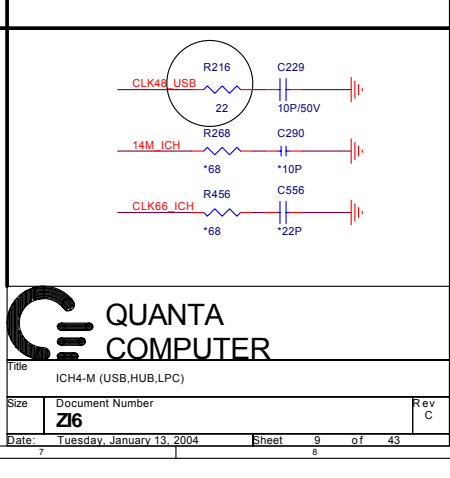
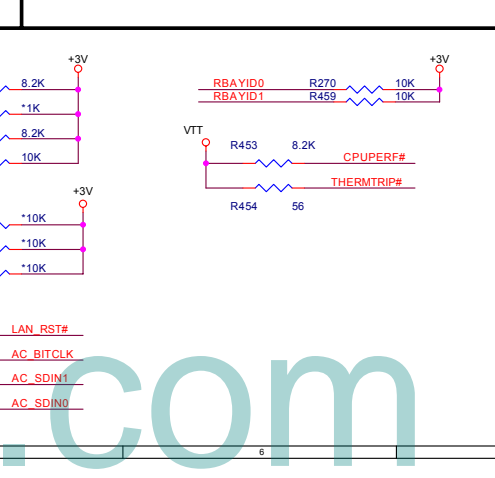
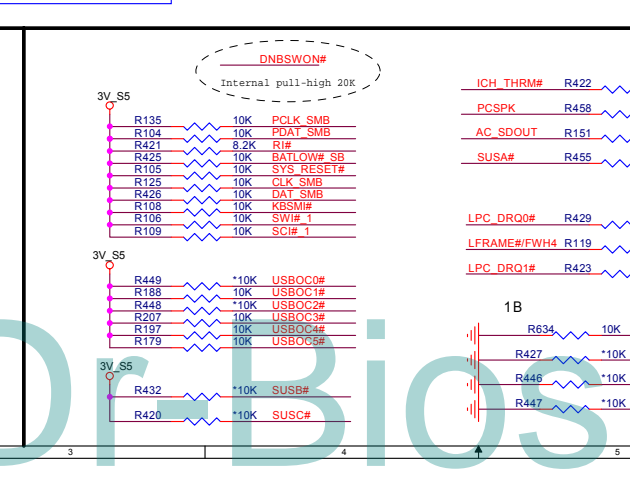
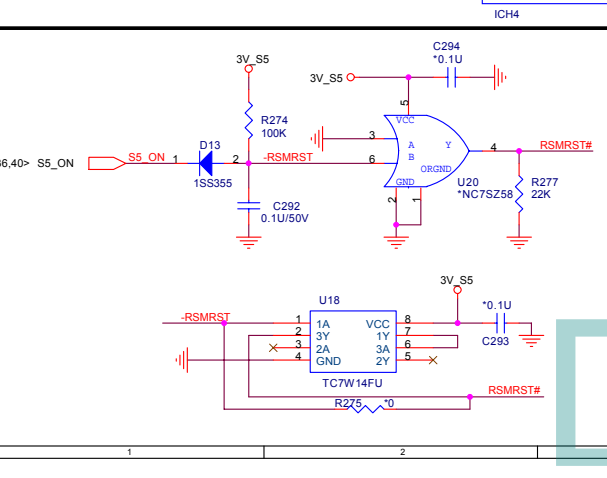
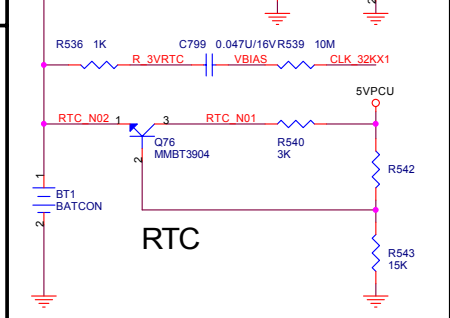
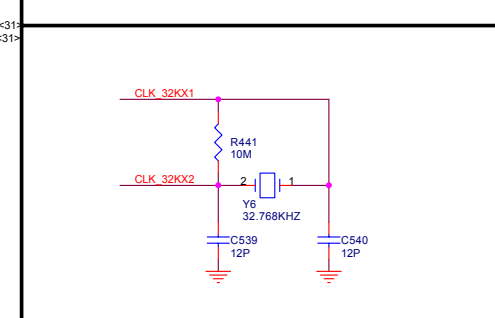
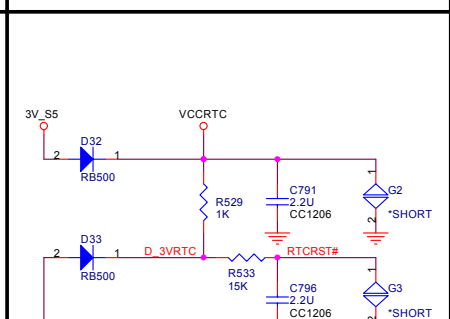
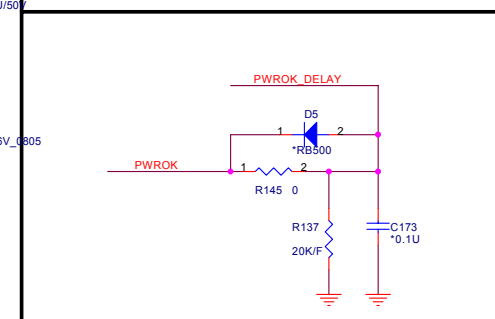
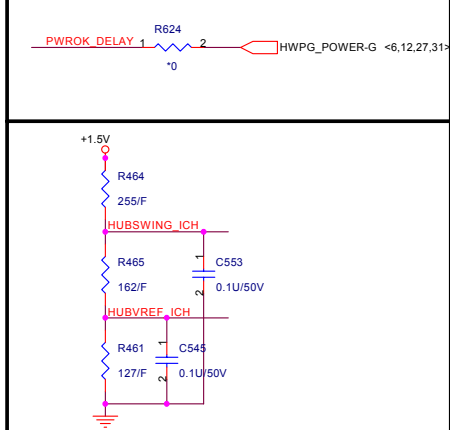
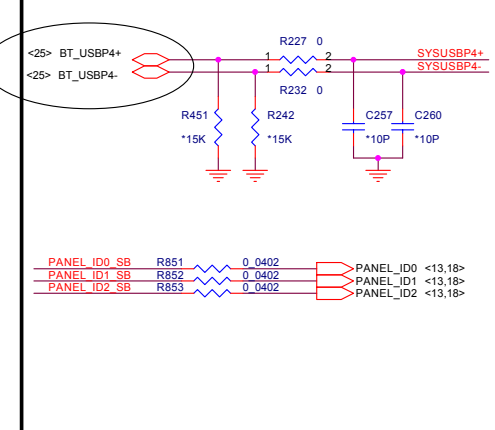
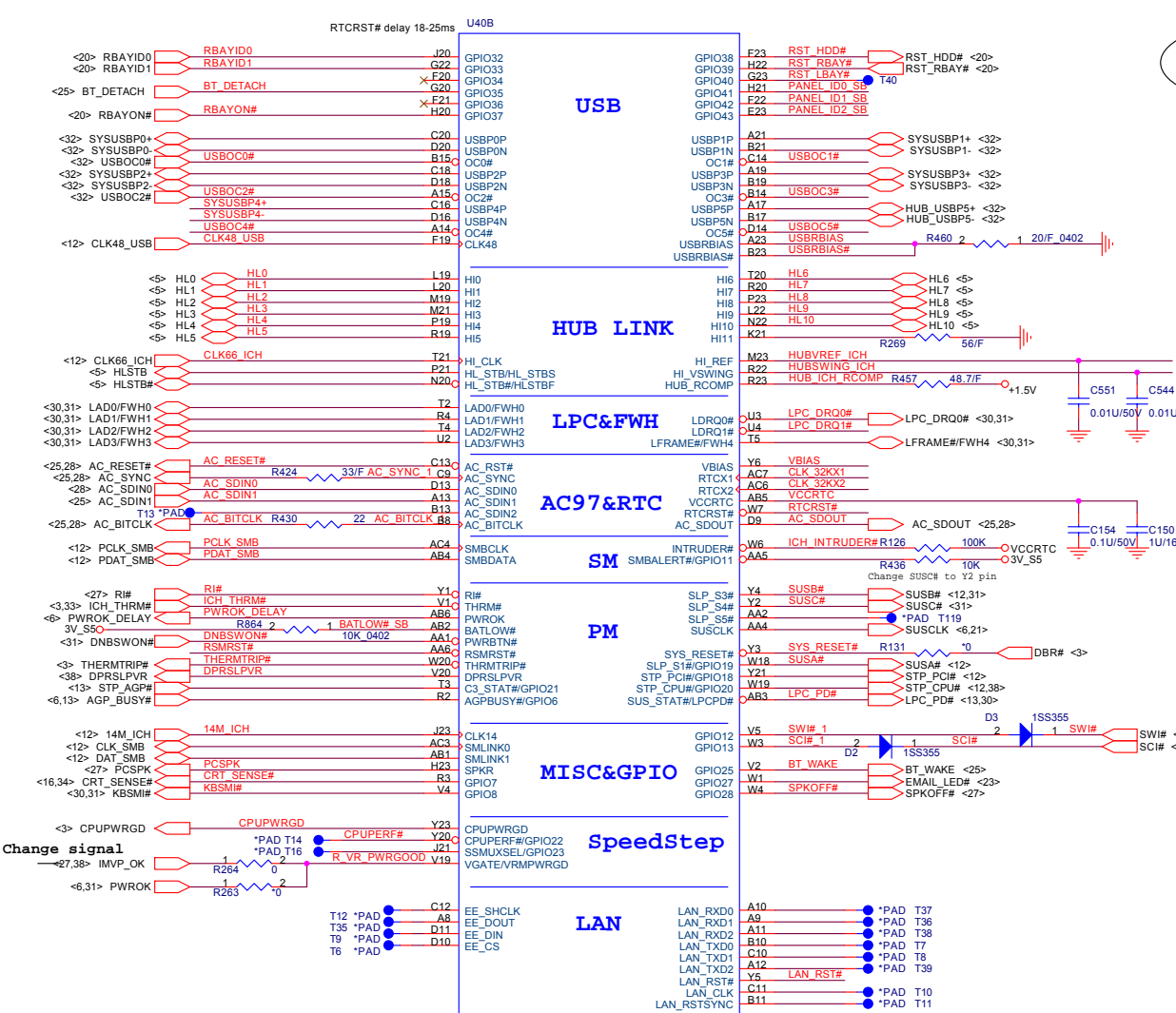

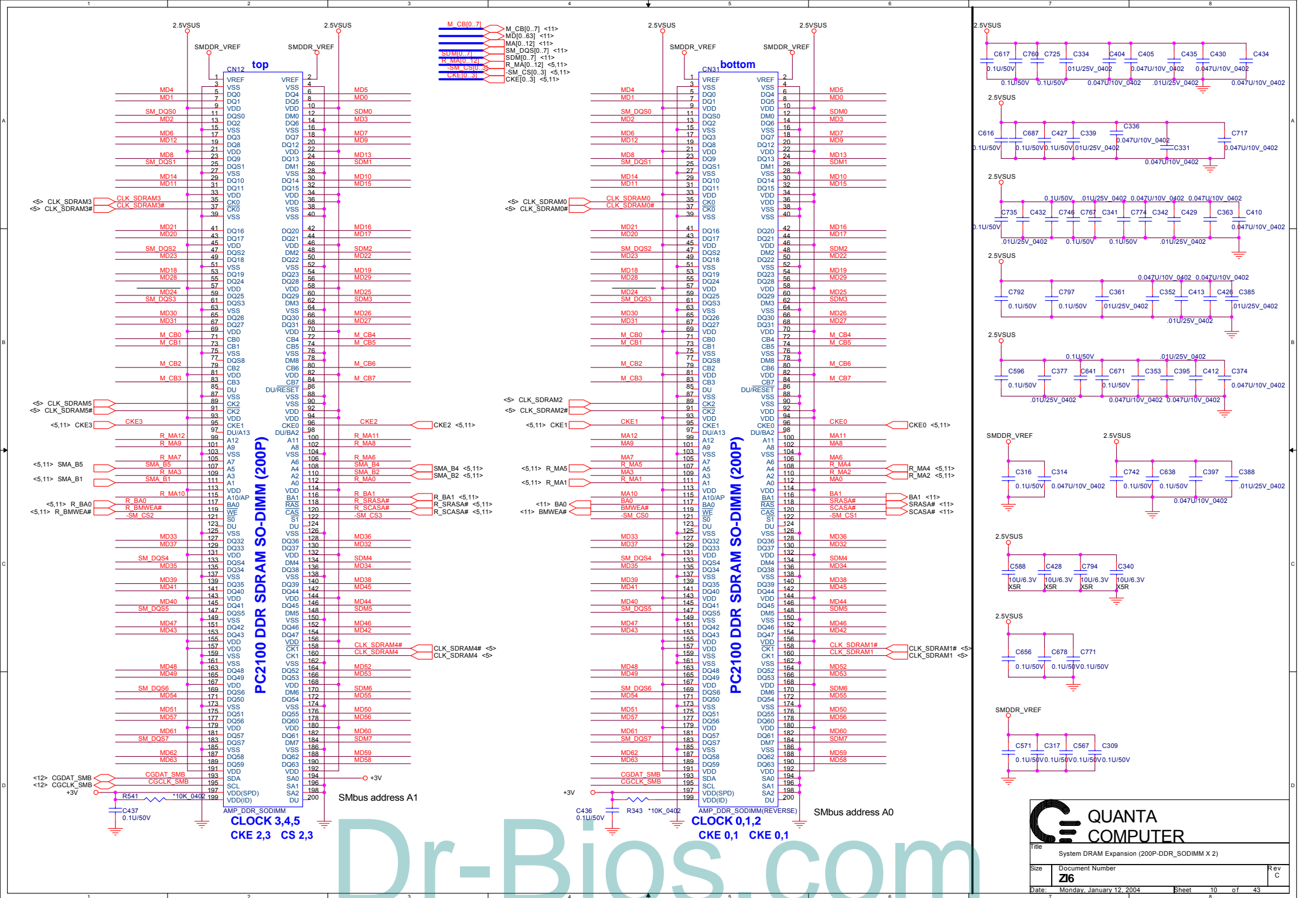

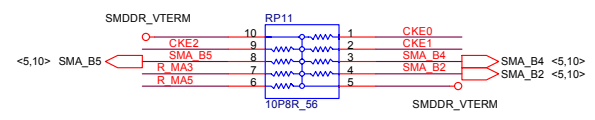
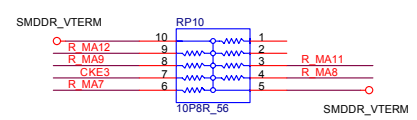
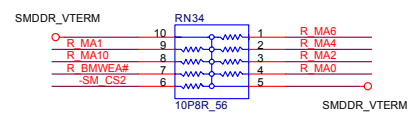
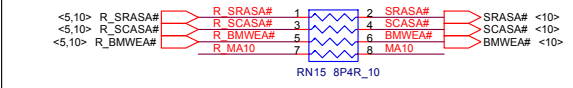
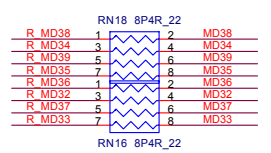
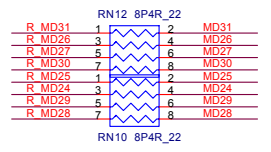
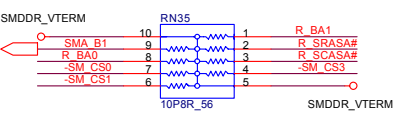
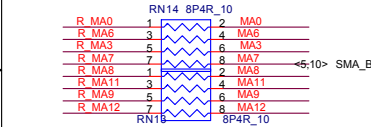
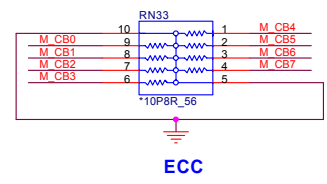
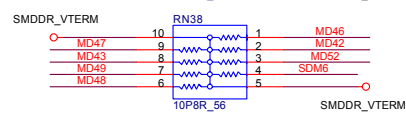
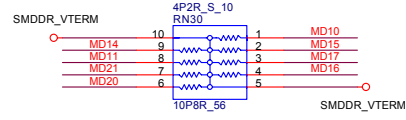
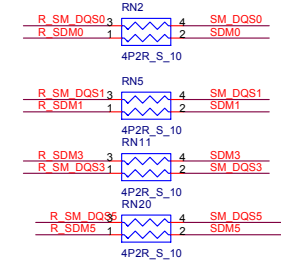
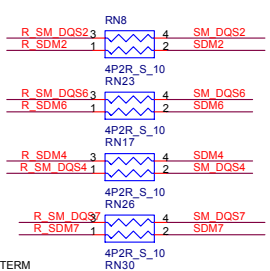
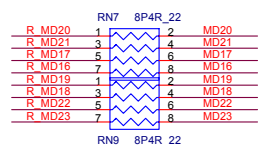
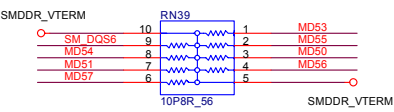
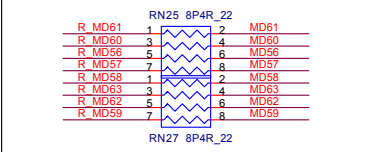
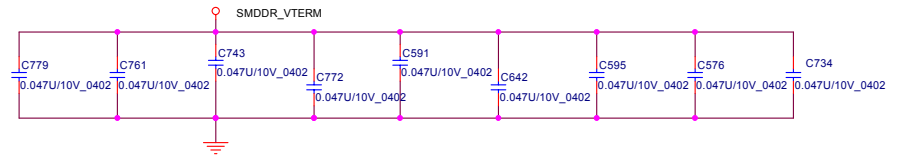
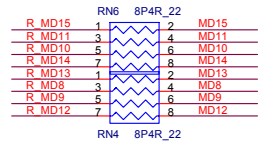
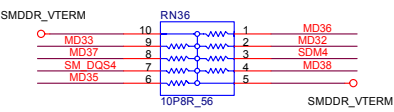
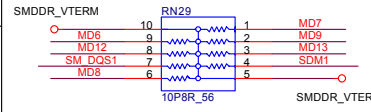
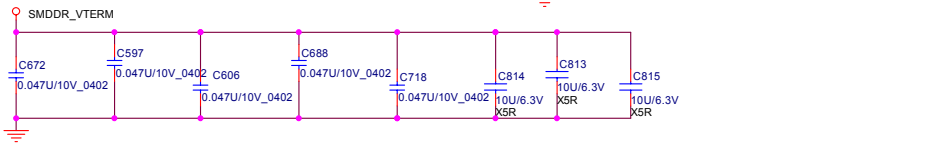
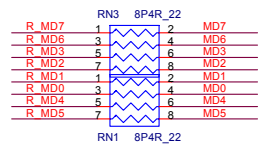
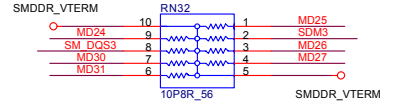
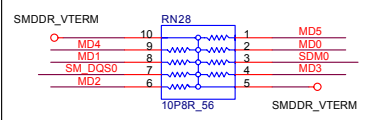
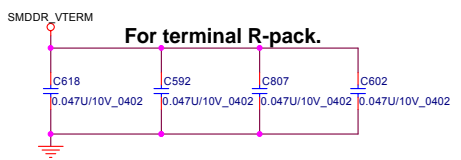
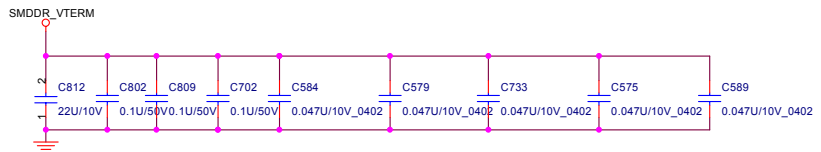
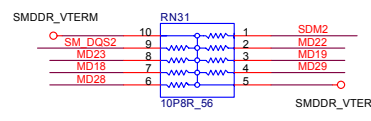
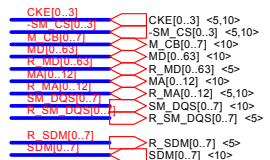

ECC



QUANTA COMPUTER

Title: DDR RES. ARRAY

Size: Document Number
Z16

Date: Monday, January 12, 2004 Sheet 11 of 43

S2	S1	S0	CPU	3V66[0..4]	3V66_5/66IN
1	0	0	66	66IN	66 Input
1	0	1	100	66IN	66 Input
1	1	0	200	66IN	66 Input
1	1	1	133	66IN	66 Input
0	0	0	66	66	66 Input
0	0	1	100	66	66 Input
0	1	0	200	66	66 Input
0	1	1	133	66	66 Input

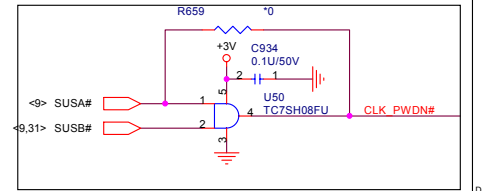
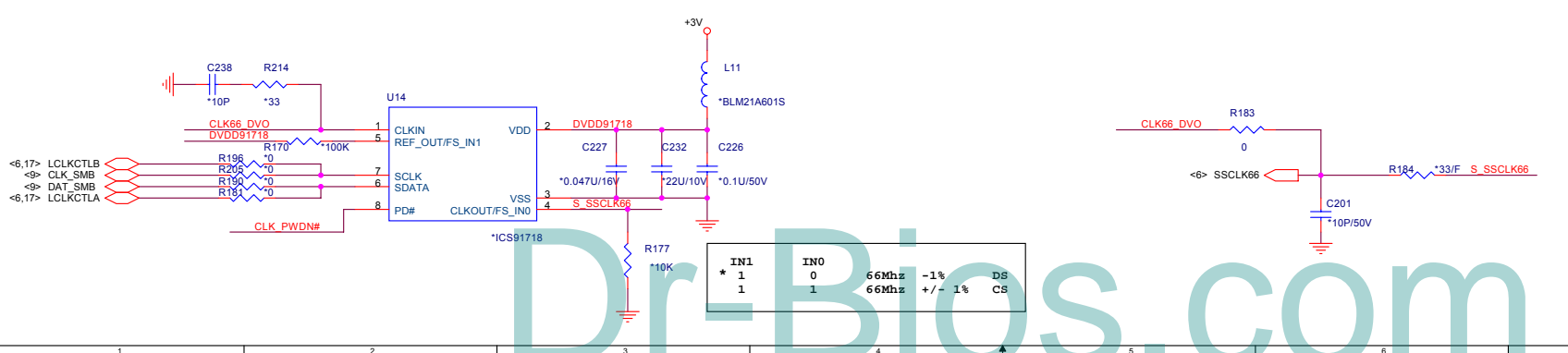
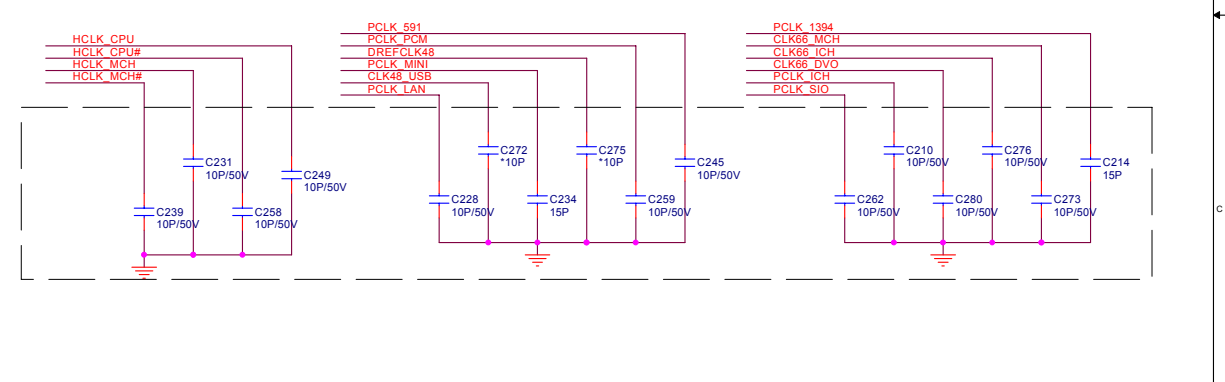
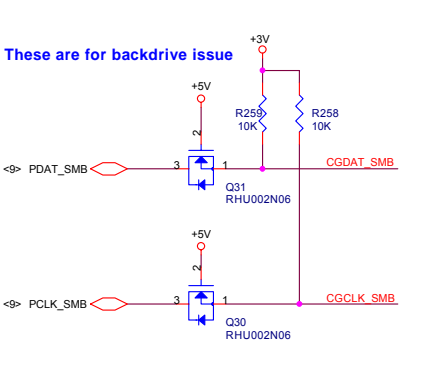
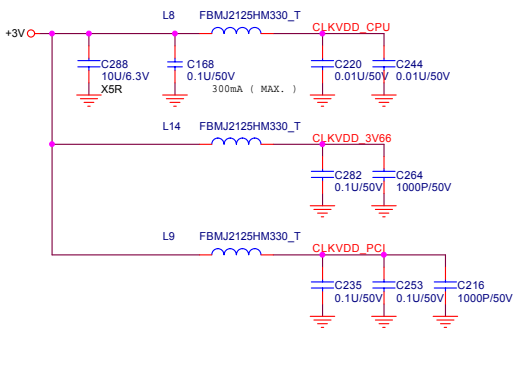
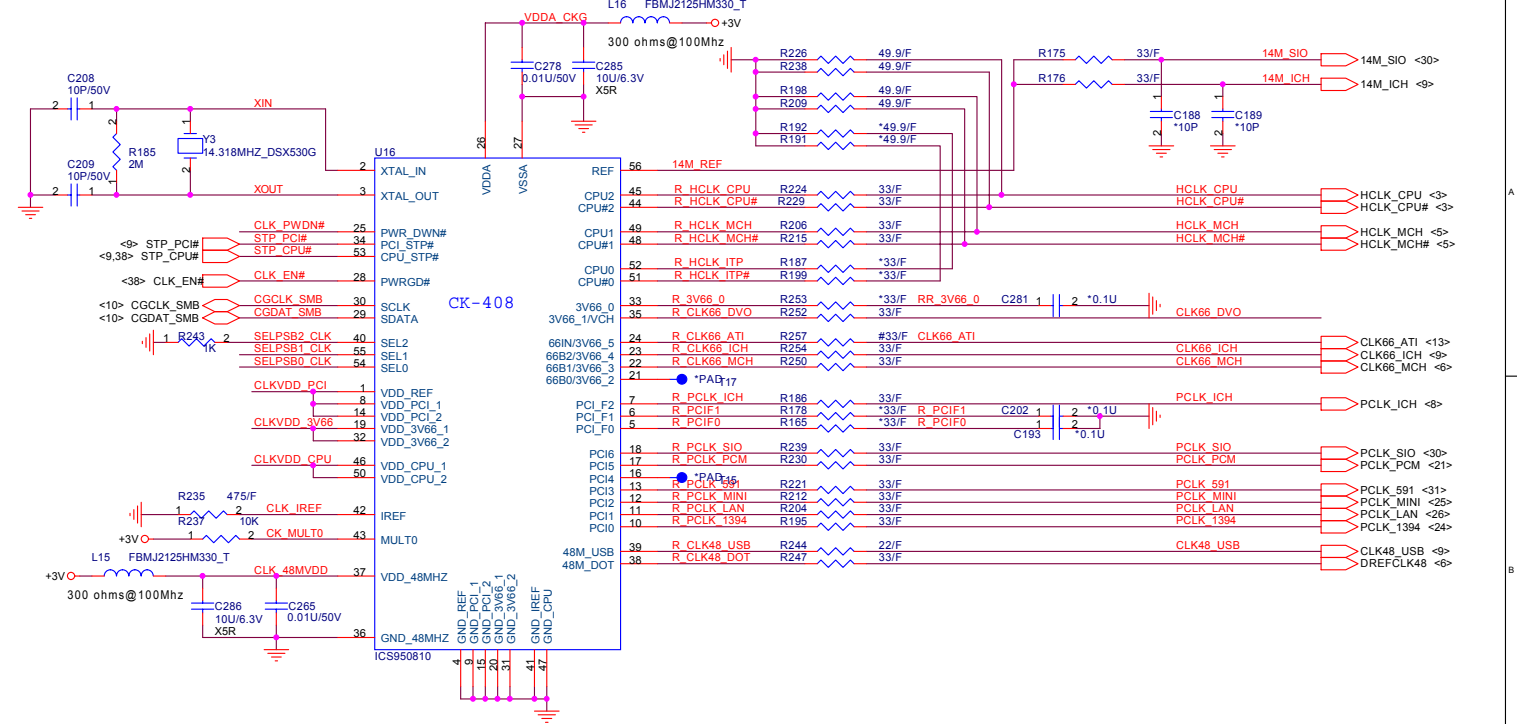
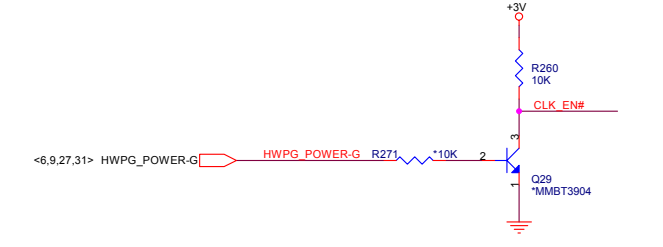
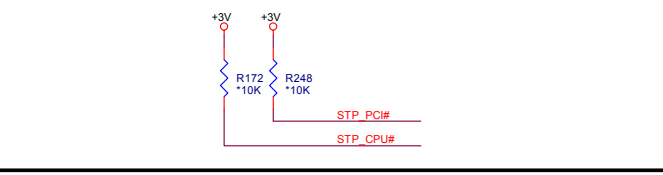
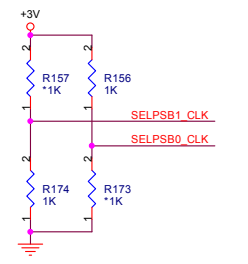

QUANTA COMPUTER

Title: CLOCK GENERATOR

Size: Document Number **Z16**

Date: Tuesday, January 13, 2004 Sheet 12 of 43

Dr-Bios.com

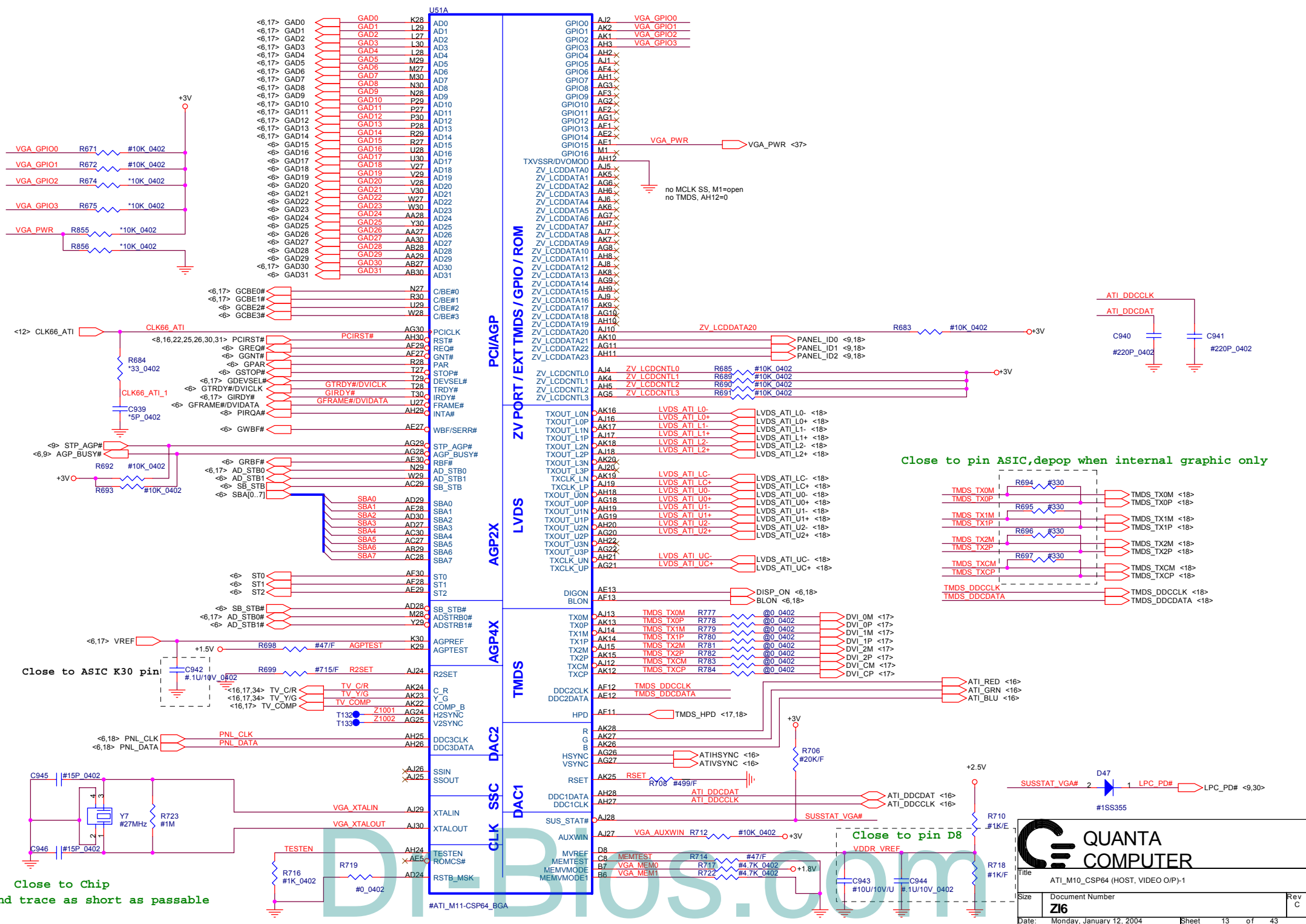

Close to pin ASIC, depop when internal graphic only

Close to ASIC K30 pin

Close to pin D8

Close to Chip
And trace as short as passable



File		ATI_M10_CSP64 (HOST, VIDEO O/P)-1	
Size	Document Number	Z16	
Date:	Monday, January 12, 2004	Sheet	13 of 43

DIOS.COM

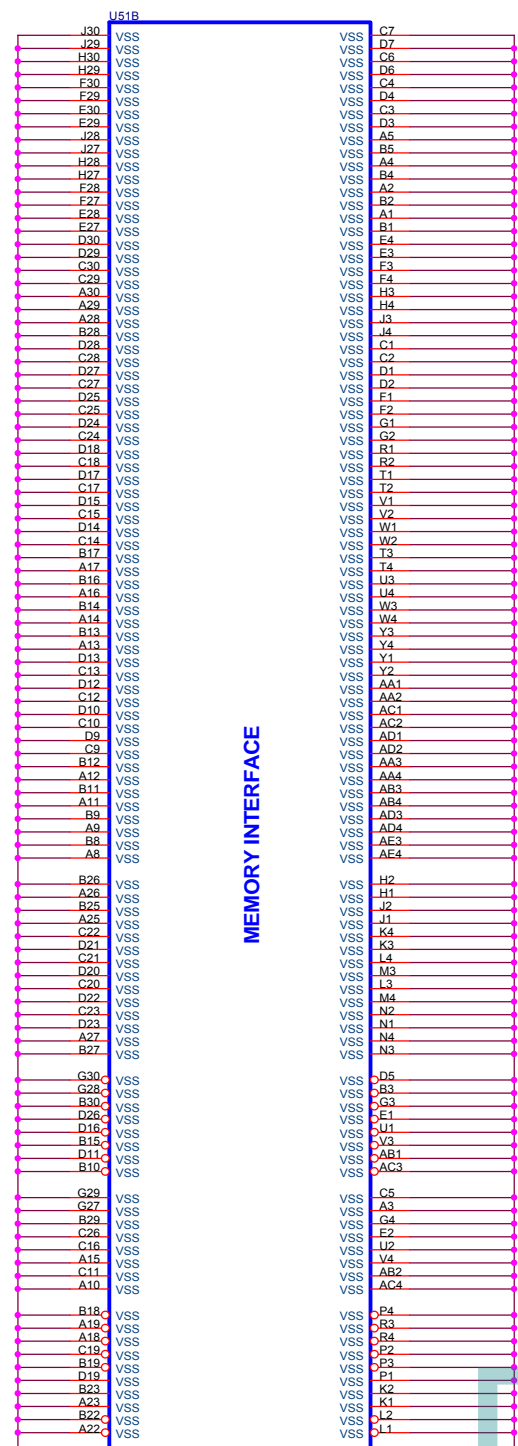

#ATI_M11-CSP64_BGA

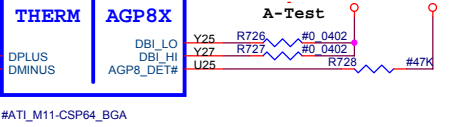
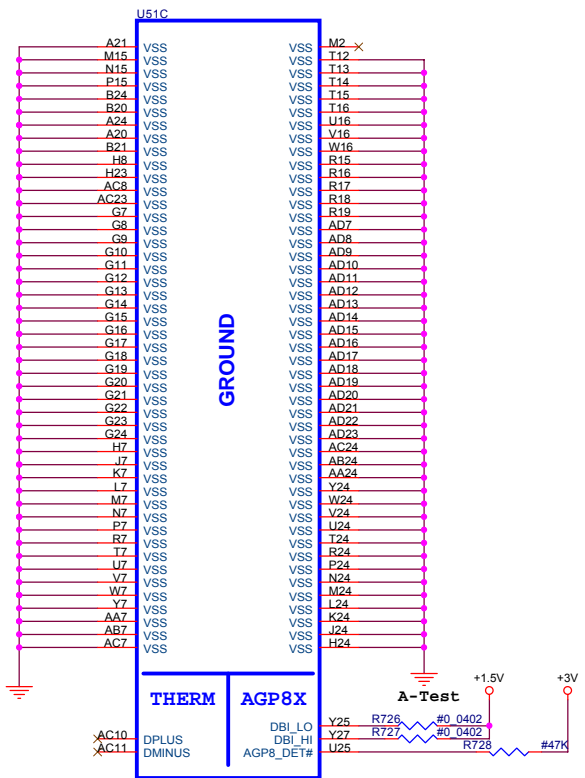

#ATI_M11-CSP64_BGA

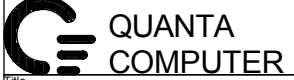

			
			Title: AT1_M10_CSP64_DDR
Size:	Document Number:	Rev C	
Date: Monday, January 12, 2004		Sheet:	14 of 43

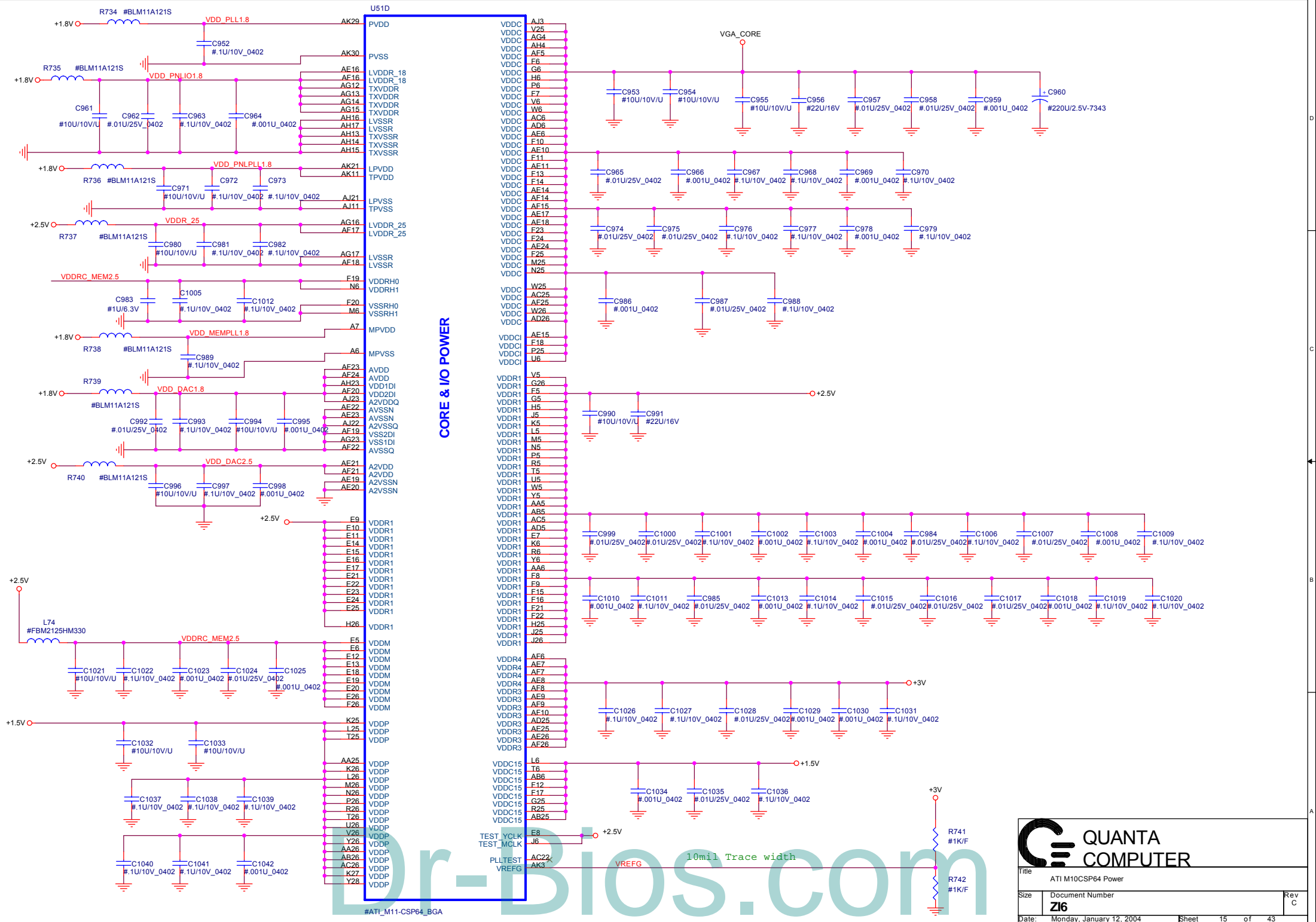

QUANTA COMPUTER

Title: ATI M10CSP64 Power

Size	Document Number	Rev C
	Z16	

Date: Monday, January 12, 2004 Sheet 15 of 43

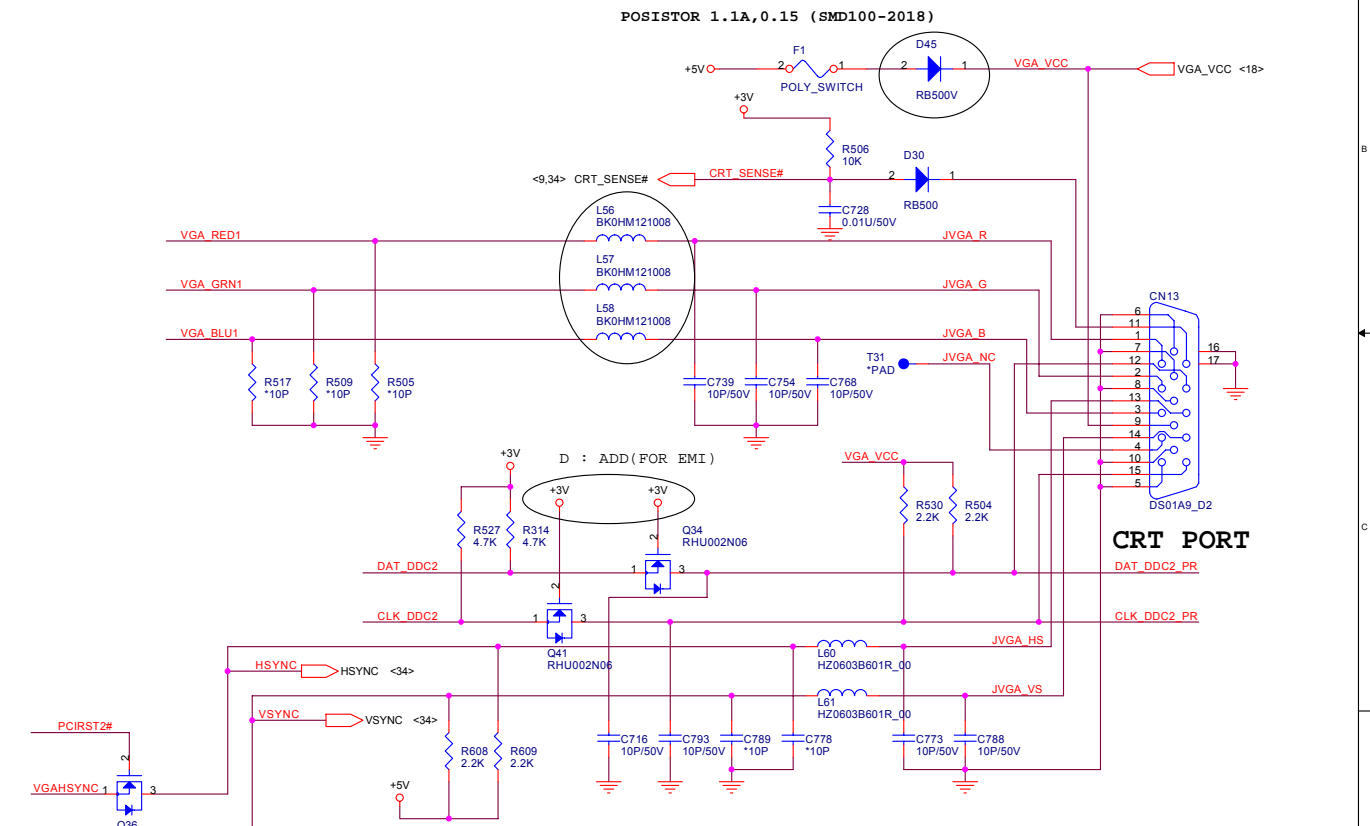
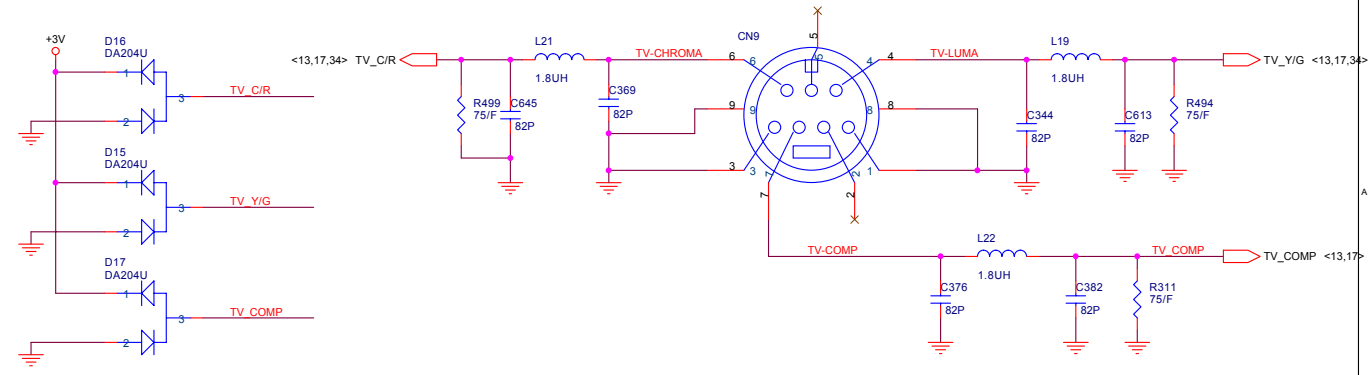
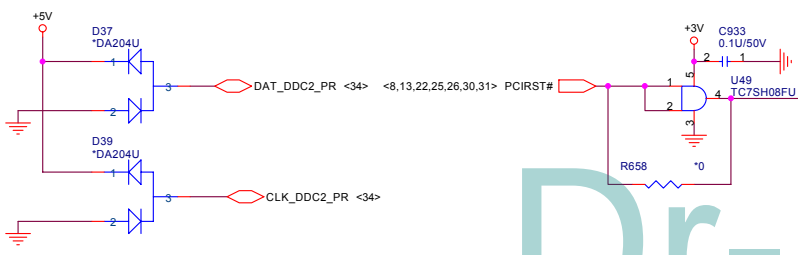
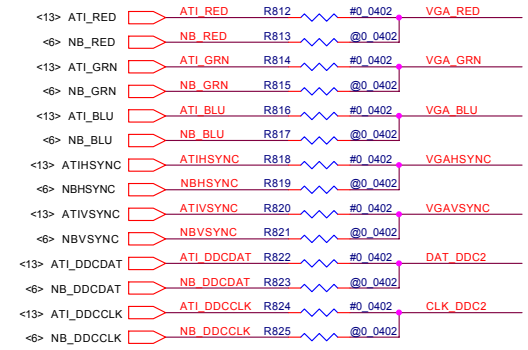
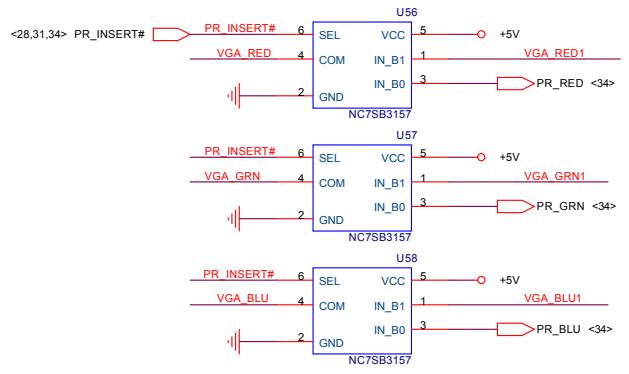

Dr-Bios.com

QUANTA COMPUTER

Title: CRT & TV-OUT

Size: Document Number **Z16** Rev C

Date: Monday, January 12, 2004 Sheet 16 of 43

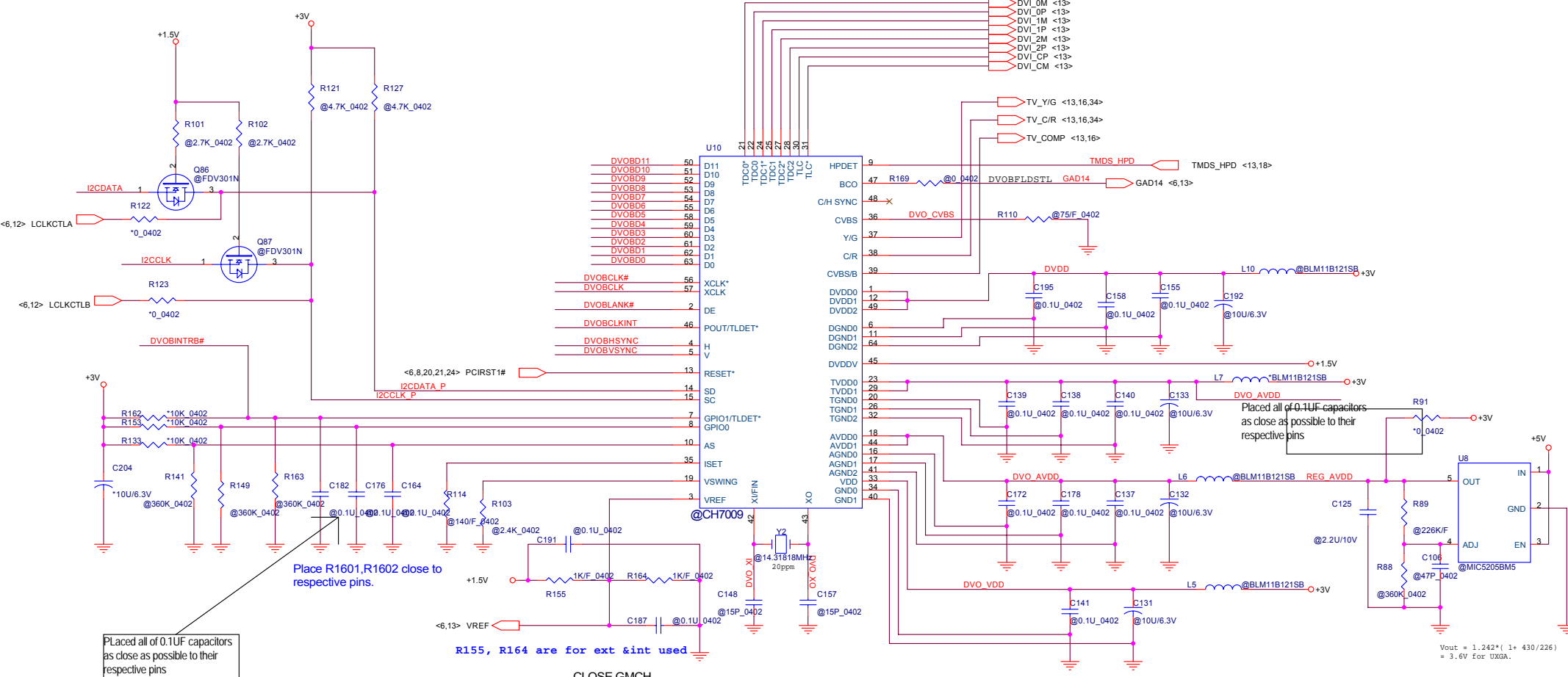

Placed all of 0.1UF capacitors as close as possible to their respective pins

Place R1601,R1602 close to respective pins.

R155, R164 are for ext &int used

CLOSE GMCH

DVOBCLK#	66MHz
DVOBCLK	66MHz
DVOBLANK#	56KHz
DVOBCLKINT	66MHz
DVOBHSYNC	56KHz
DVOBVSYNC	60Hz

<6,13> GAD11	R827	@0.0402	DVOBD11
<6,13> GAD12	R828	@0.0402	DVOBD10
<6,13> GAD9	R829	@0.0402	DVOBD9
<6,13> GAD10	R830	@0.0402	DVOBD8
<6,13> GAD8	R831	@0.0402	DVOBD7
<6,13> GAD6	R832	@0.0402	DVOBD6
<6,13> GAD7	R833	@0.0402	DVOBD5
<6,13> GAD4	R834	@0.0402	DVOBD4
<6,13> GAD5	R835	@0.0402	DVOBD3
<6,13> GAD2	R836	@0.0402	DVOBD2
<6,13> GAD3	R837	@0.0402	DVOBD1
<6,13> AD_STB0#	R838	@0.0402	DVOBCLK#
<6,13> AD_STB0	R840	@0.0402	DVOBCLK
<6,13> GAD13	R841	@0.0402	DVOBLANK#
<6,13> GAD13	R842	@0.0402	DVOBCLKINT
<6,13> GAD0	R843	@0.0402	DVOBHSYNC
<6,13> GAD1	R844	@0.0402	DVOBVSYNC
<6,13> GAD30	R861	@0.0402	DVOINTRB#
<6,13> GDEVSEL#	R862	@0.0402	I2CDATA
<6,13> GIRDY#	R863	@0.0402	I2CCLK

QUANTA COMPUTER

Title: DVO (DVI + S_VIDEO)

Size: Document Number **Z16** Rev C

Date: Monday, January 12, 2004 Sheet 17 of 43

FILTER FBM2125 HM330-T(4A,0.015)

PANEL ID:

	PANEL_ID2	PANEL_ID1	PANEL_ID0
D3	0	1	1
D4	1	0	0
D5	1	0	1
D6	1	1	0
D7	1	1	1

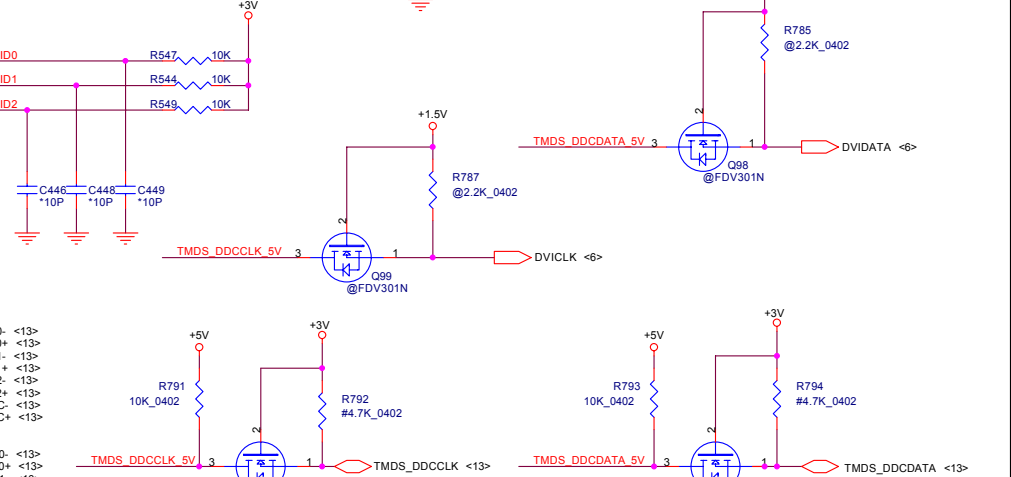
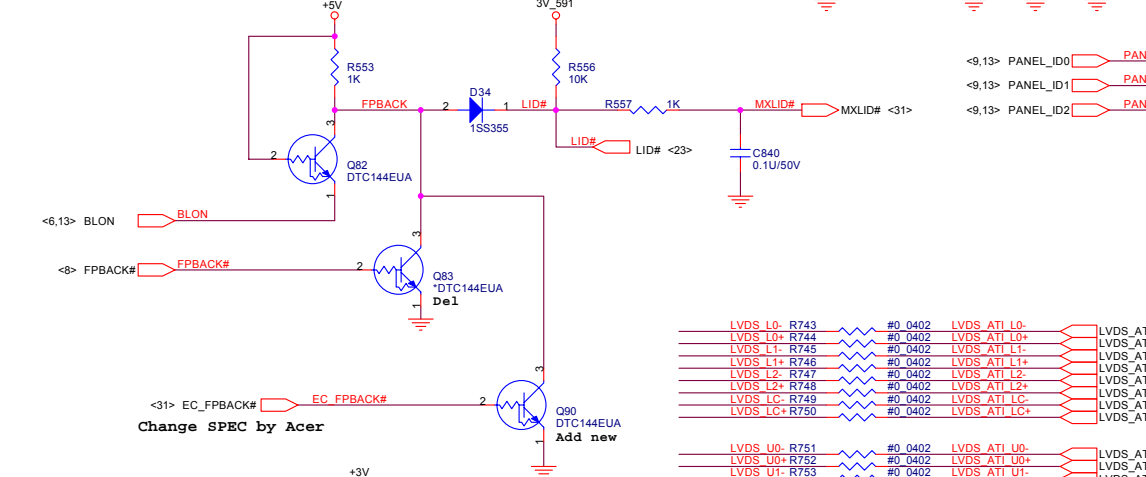
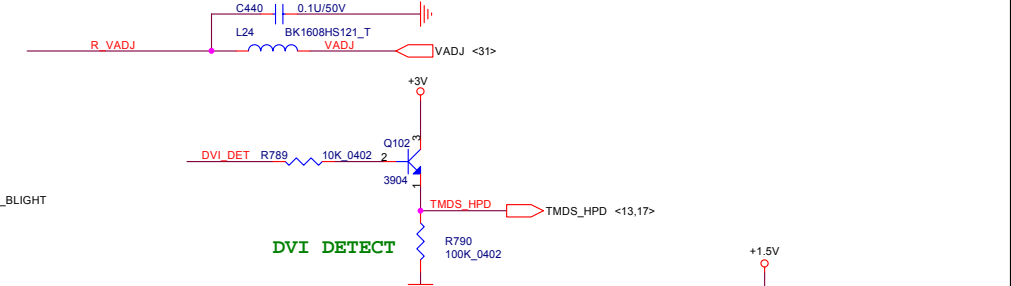
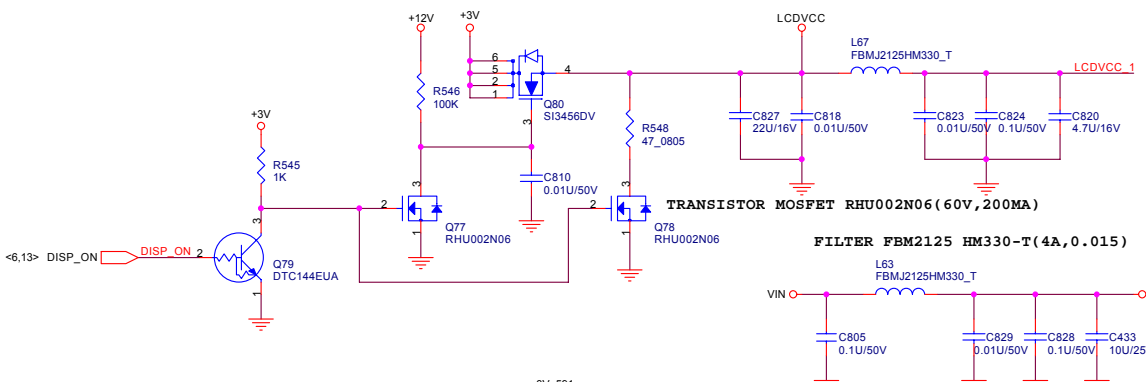

- LVDS L0- R743 #0 0402 LVDS ATI L0- LVDS ATI L0- <13>
- LVDS L0+ R744 #0 0402 LVDS ATI L0+ LVDS ATI L0+ <13>
- LVDS L1- R745 #0 0402 LVDS ATI L1- LVDS ATI L1- <13>
- LVDS L1+ R746 #0 0402 LVDS ATI L1+ LVDS ATI L1+ <13>
- LVDS L2- R747 #0 0402 LVDS ATI L2- LVDS ATI L2- <13>
- LVDS L2+ R748 #0 0402 LVDS ATI L2+ LVDS ATI L2+ <13>
- LVDS LC- R749 #0 0402 LVDS ATI LC- LVDS ATI LC- <13>
- LVDS LC+ R750 #0 0402 LVDS ATI LC+ LVDS ATI LC+ <13>
- LVDS U0- R751 #0 0402 LVDS ATI U0- LVDS ATI U0- <13>
- LVDS U0+ R752 #0 0402 LVDS ATI U0+ LVDS ATI U0+ <13>
- LVDS U1- R753 #0 0402 LVDS ATI U1- LVDS ATI U1- <13>
- LVDS U1+ R754 #0 0402 LVDS ATI U1+ LVDS ATI U1+ <13>
- LVDS U2- R755 #0 0402 LVDS ATI U2- LVDS ATI U2- <13>
- LVDS U2+ R756 #0 0402 LVDS ATI U2+ LVDS ATI U2+ <13>
- LVDS UC- R757 #0 0402 LVDS ATI UC- LVDS ATI UC- <13>
- LVDS UC+ R758 #0 0402 LVDS ATI UC+ LVDS ATI UC+ <13>

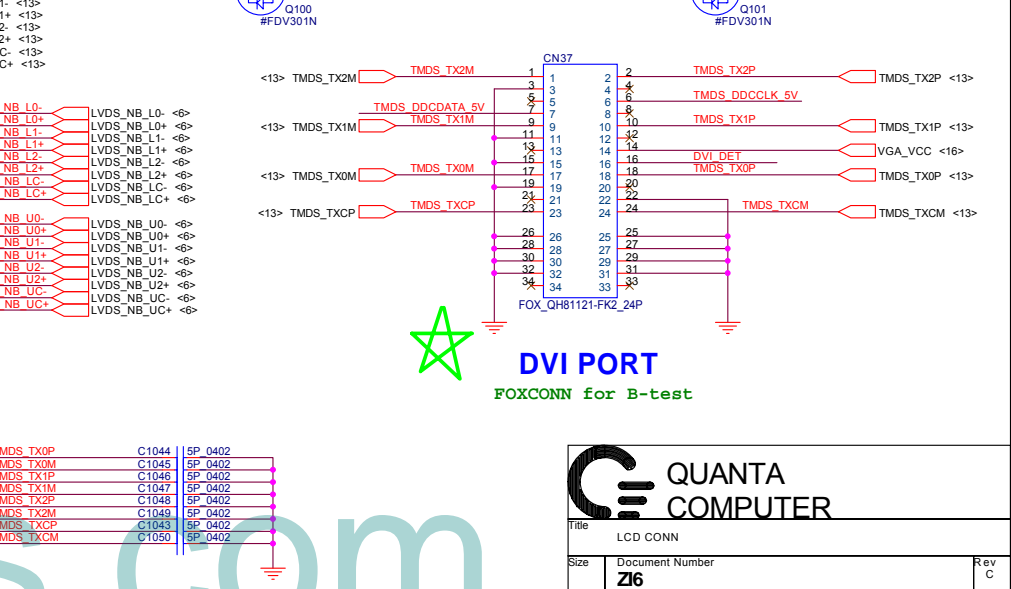
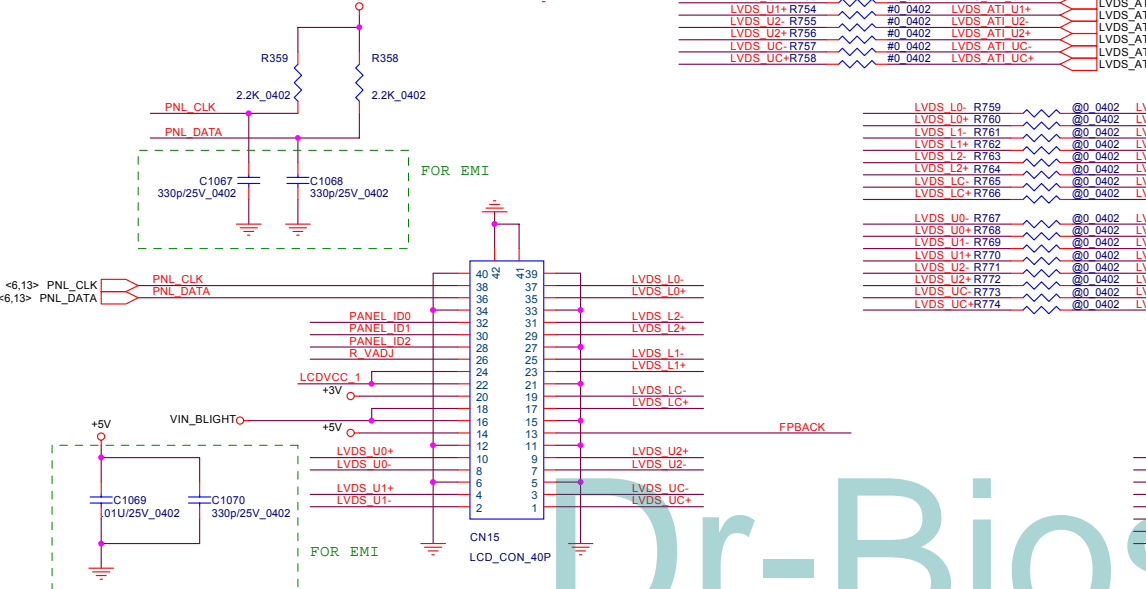

★
DVI PORT
FOXCONN for B-test

QUANTA COMPUTER

Title: LCD CONN

Size: Document Number: **Z16**

Date: Monday, January 12, 2004 Sheet 18 of 43

Dr-Bios.com

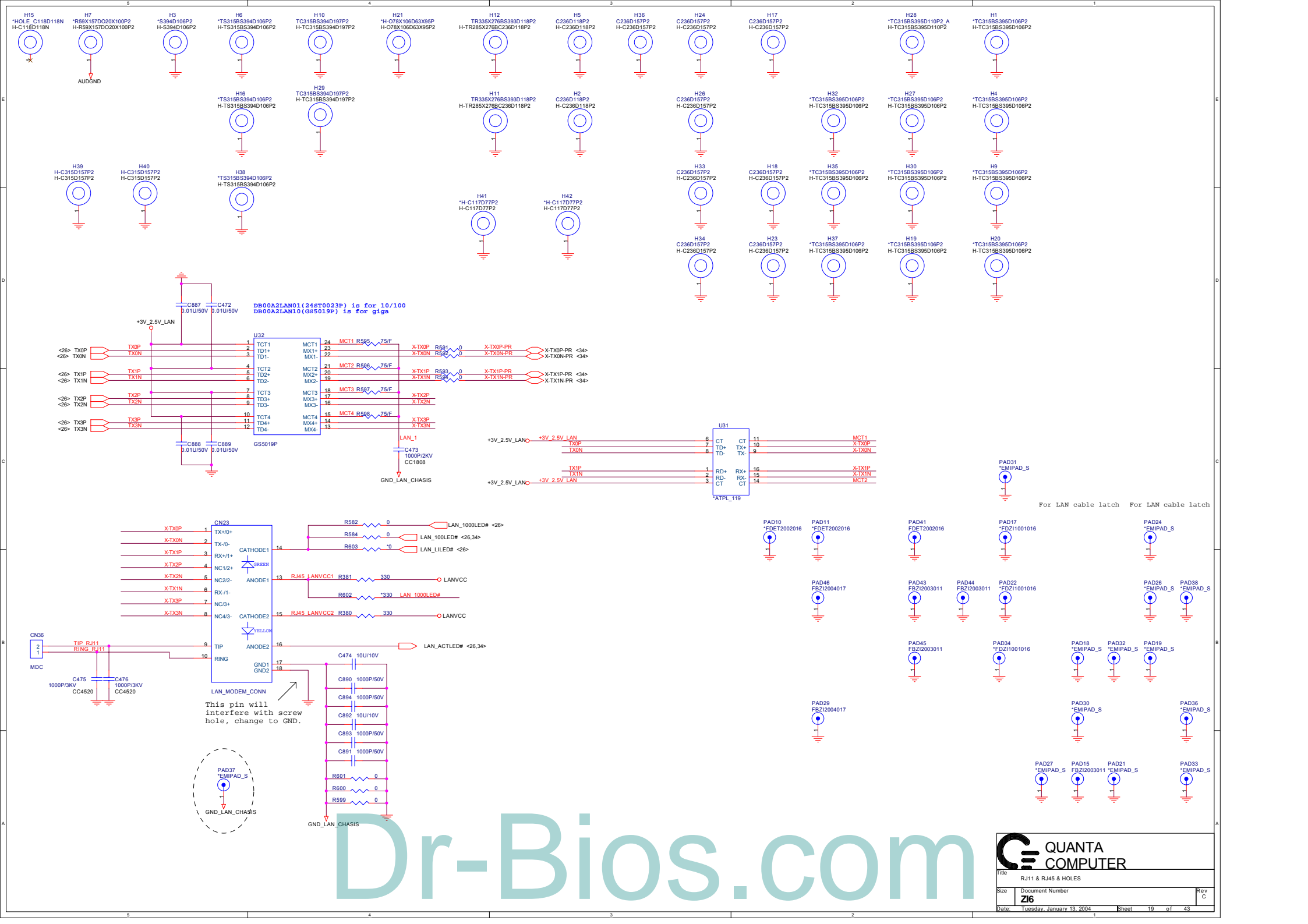

Dr-Bios.com

QUANTA COMPUTER

title RJ11 & RJ45 & HOLES

Size Document Number

Z16

Date: Tuesday, January 13, 2004 Sheet 19 of 43

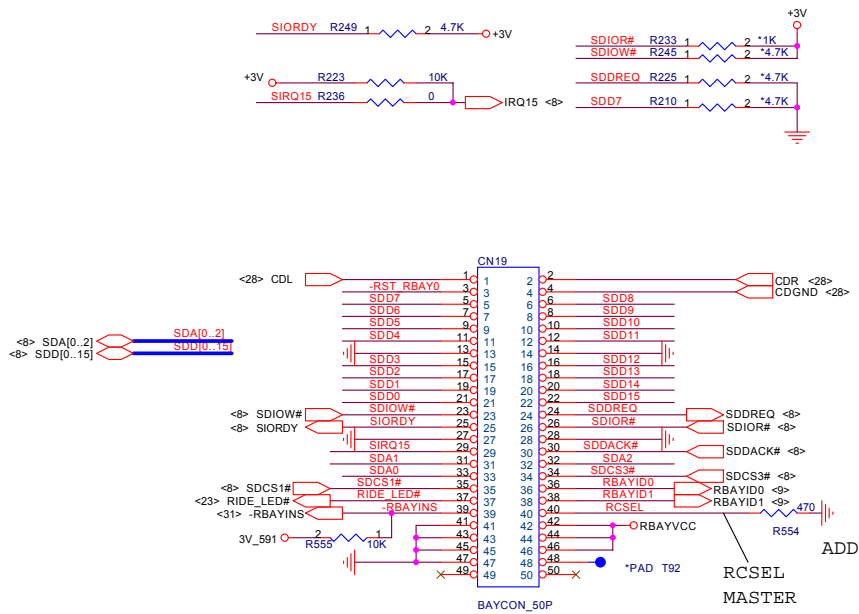

BAY ID STATUS

RBAYID0/ LBAYID0	RBAYID1/ LBAYID1	STATUS
0	0	FDD
0	1	HDD
1	0	CD/DVD

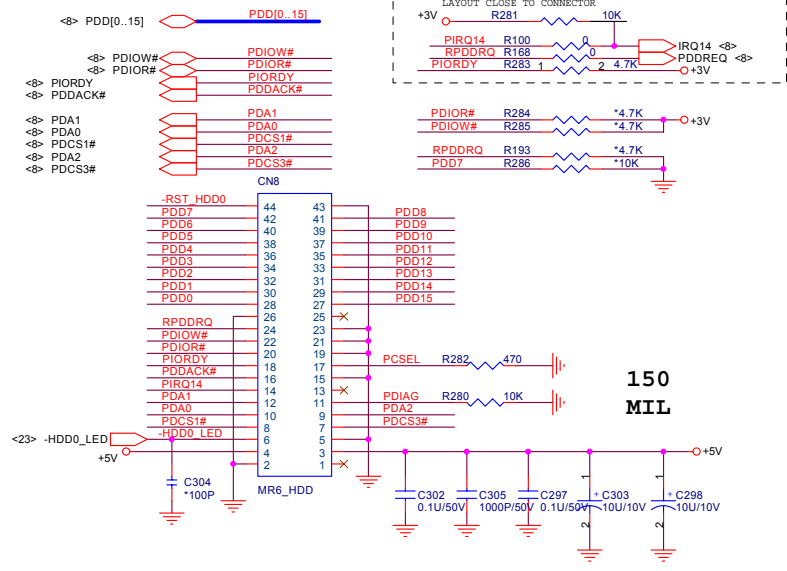

HDD CONNECTOR

SWAP BAY: OPTICAL DRIVE, 2ND BATTERY, 2ND HDD

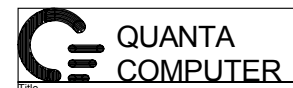
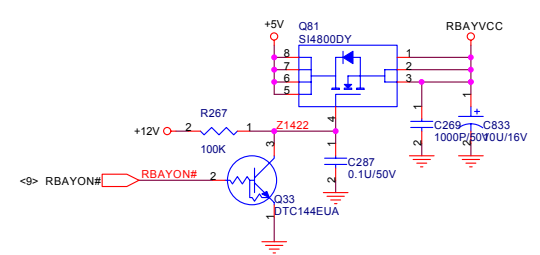
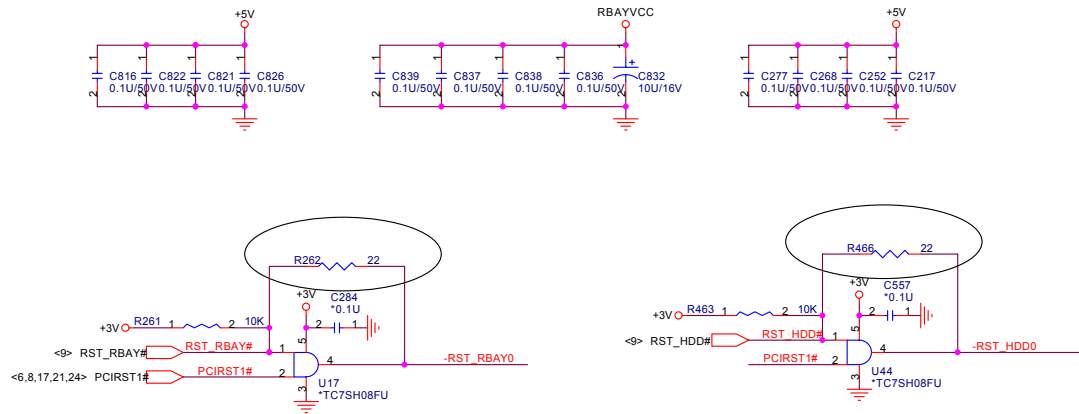

Title		DEVICE BAY
Size	Document Number	Rev C
Date: Monday, January 12, 2004		Sheet 20 of 43

Dr-Bios.com

SWAP BAY POWER CONTROL& RESET

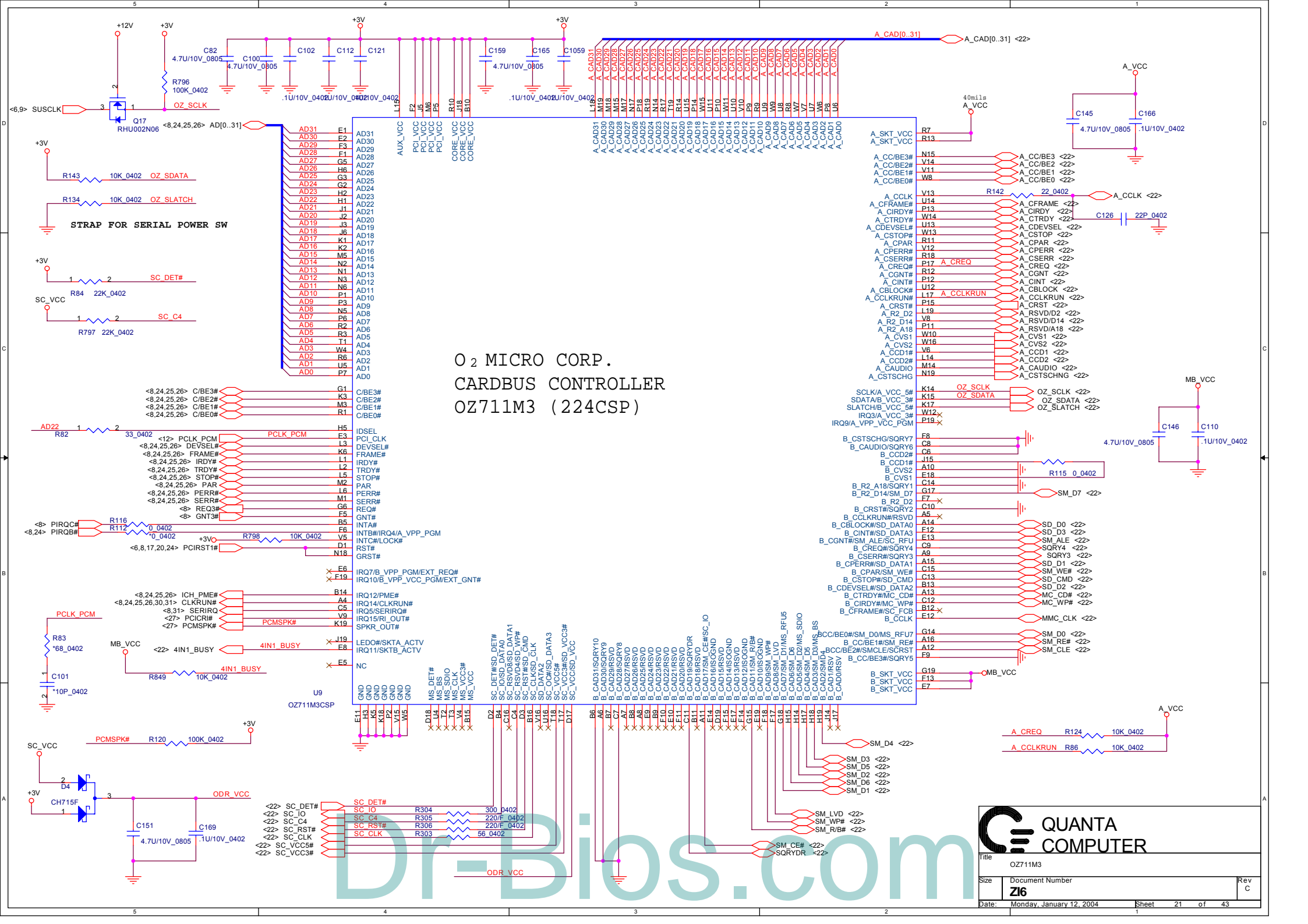

O₂ MICRO CORP.
 CARBUS CONTROLLER
 OZ711M3 (224CSP)



Title		OZ711M3	
Size	Document Number	Z16	
Date:	Monday, January 12, 2004	Sheet	21 of 43
		Rev	C

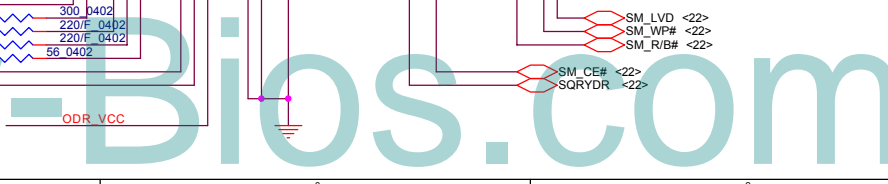

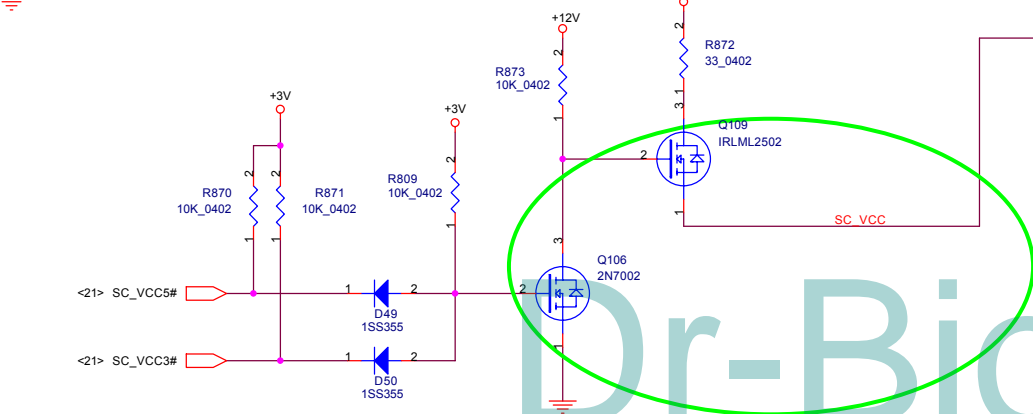
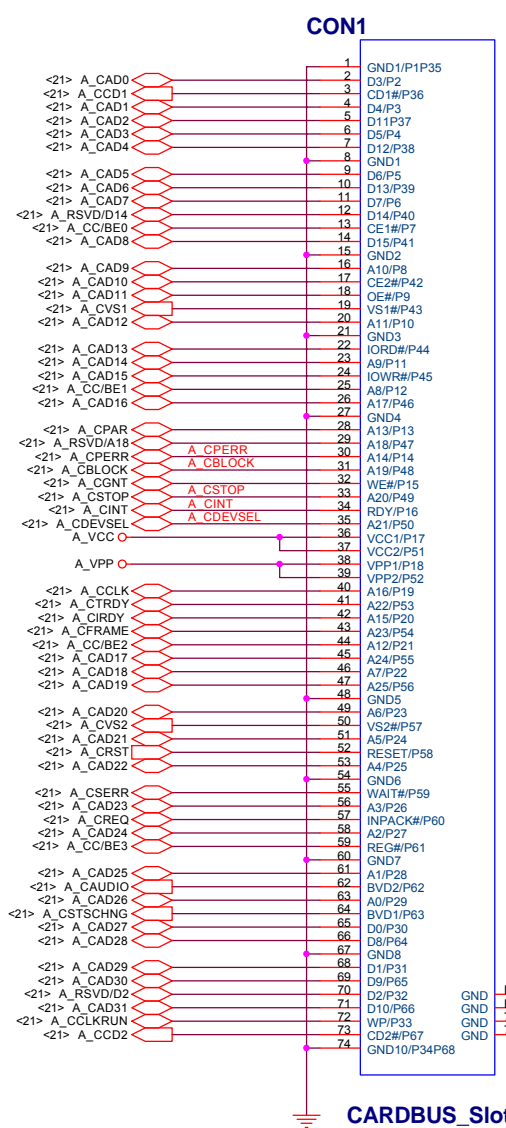
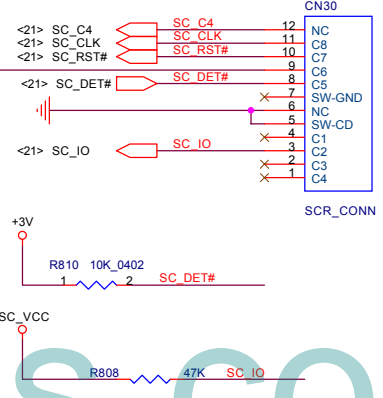
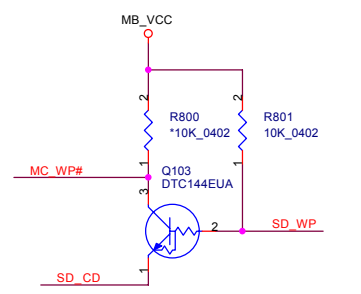
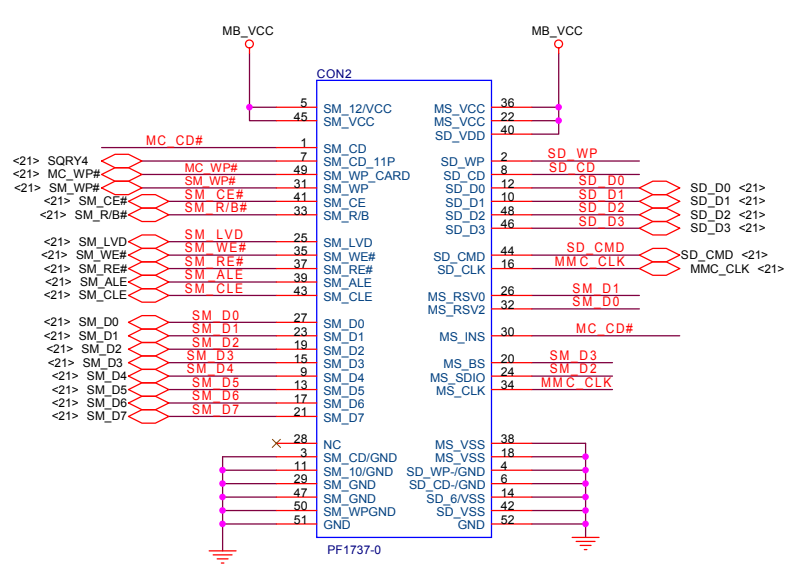
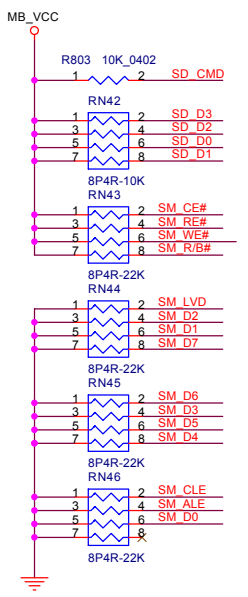
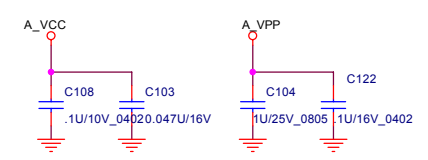
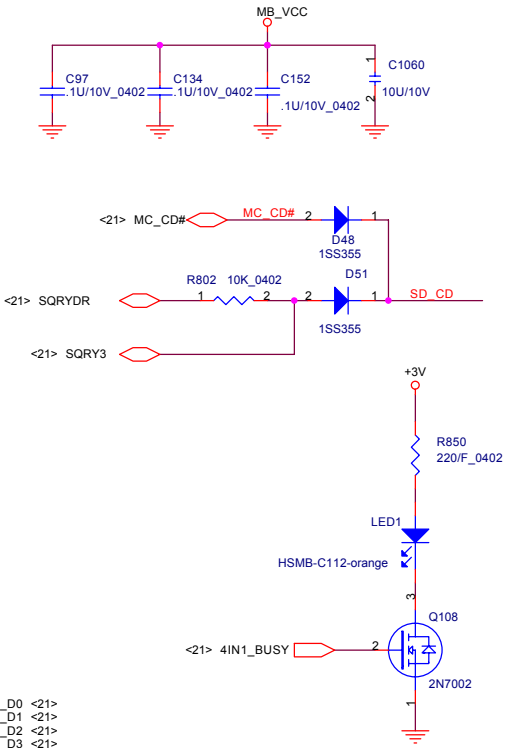
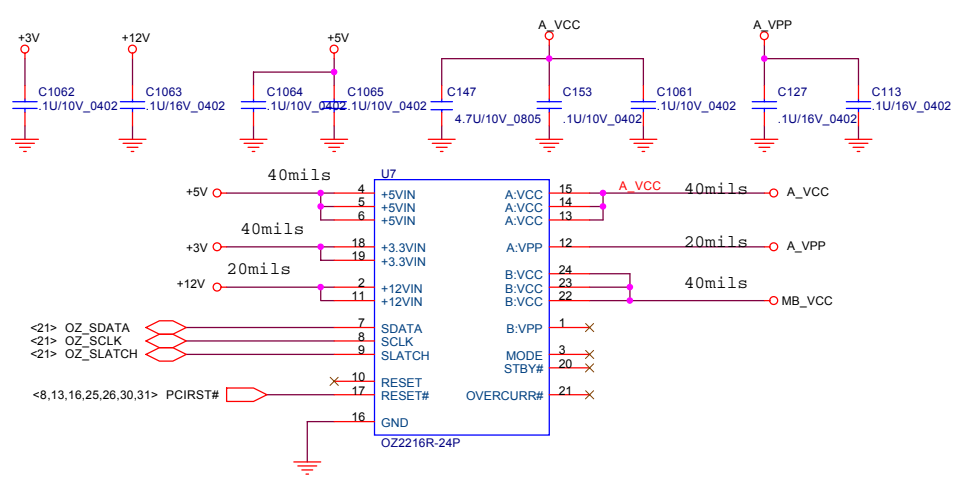

Dr-Bios.com

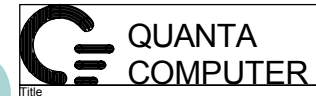

12 MIL

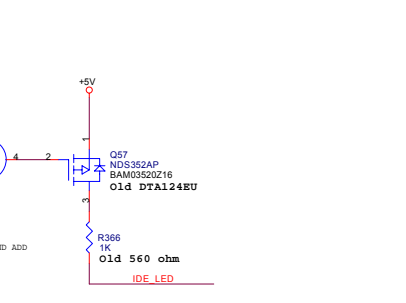
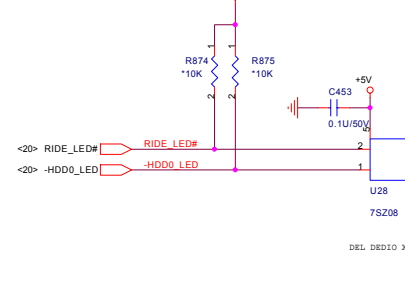
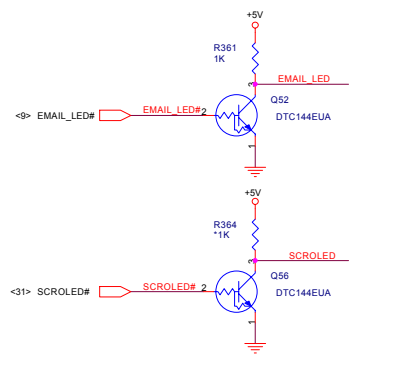
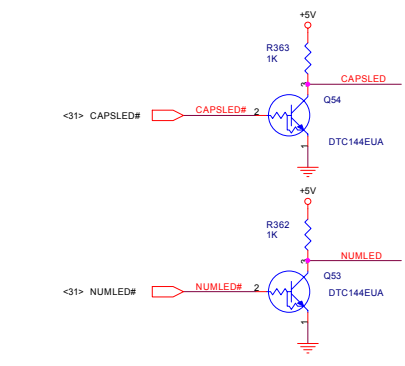
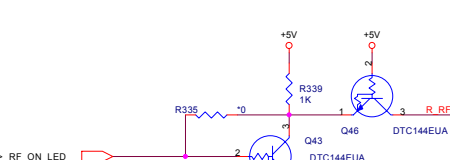
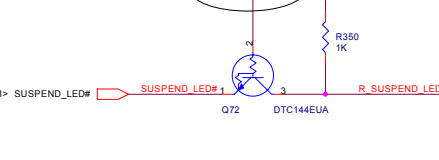
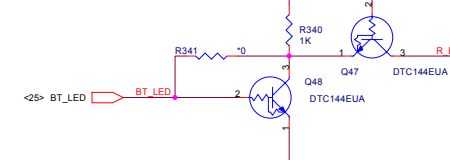
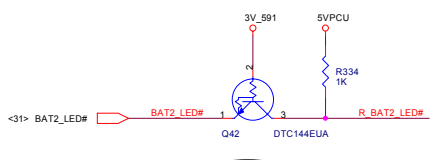
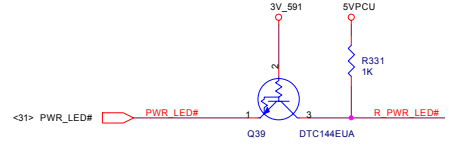
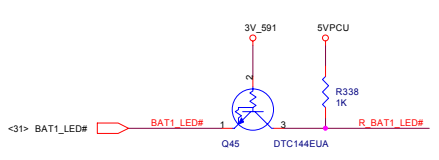
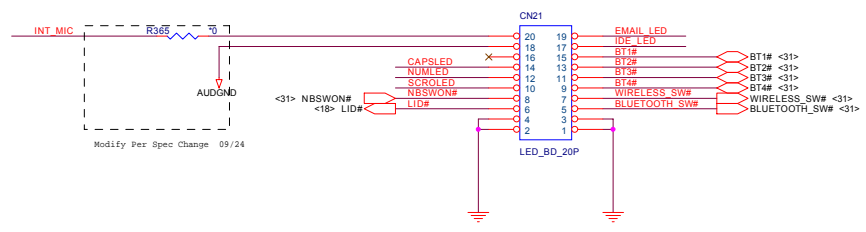
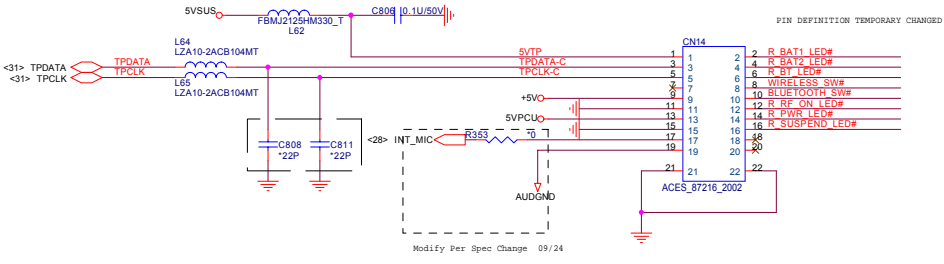

IDE LED CONTROL LOGIC

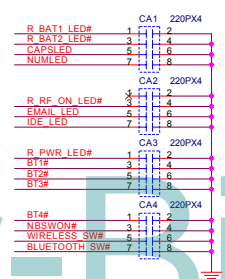
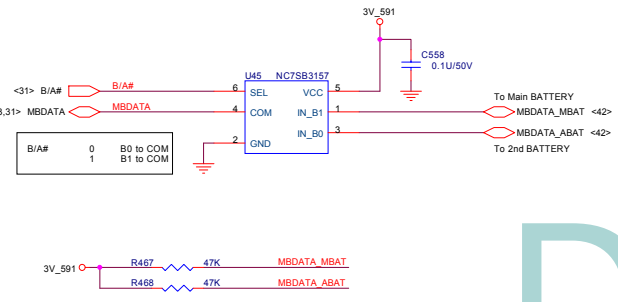

Del SW2

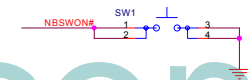

QUANTA COMPUTER

title 4-IN-1 MEMORY CARD

Size Document Number **Z16** Rev C

Date: Tuesday, January 13, 2004 Sheet 23 of 43

IEEE-1394

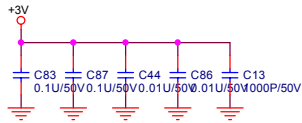

Used for vccp
(Pin20, 35, 48, 62, 78)

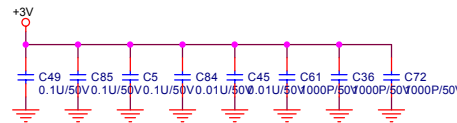

Used for vcc3
(Pin15, 27, 39, 51, 59, 72, 88, 100)

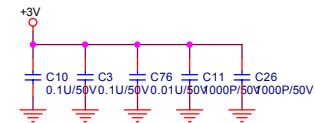

Used for AVCC
(Pin1, 2, 107, 108, 120)

ID Select : AD23
Interrupt Pin : PIRQB#
Request indicates : REQ2#
Grant indicates : GNT2#

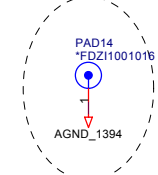
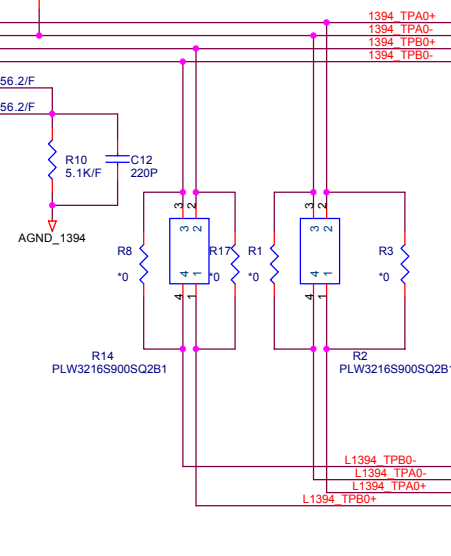
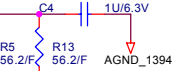
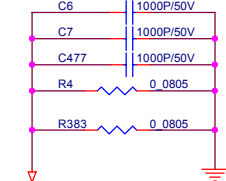
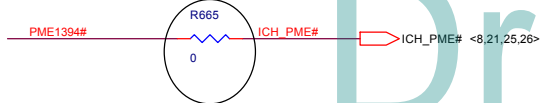
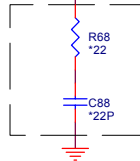
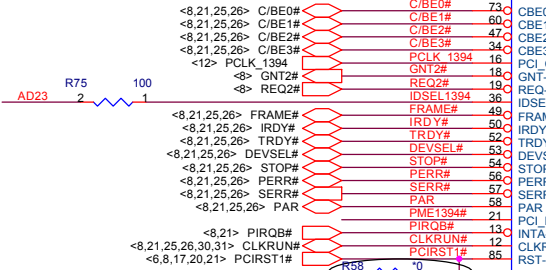
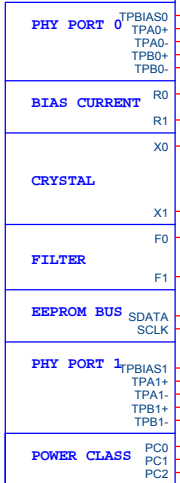
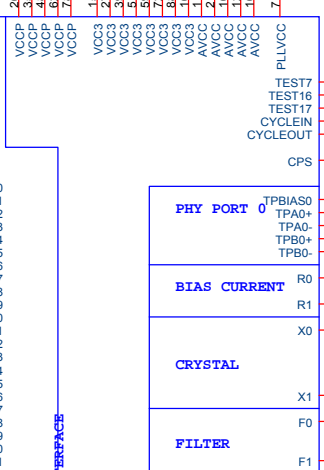
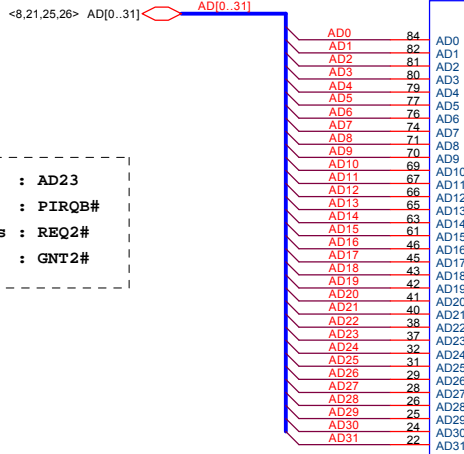

For EMI Request; PAD size is not determined yet.

QUANTA COMPUTER

Title: TSB43AB21[1394]
Size: Document Number
Z16
Date: Monday, January 12, 2004 Sheet 24 of 43

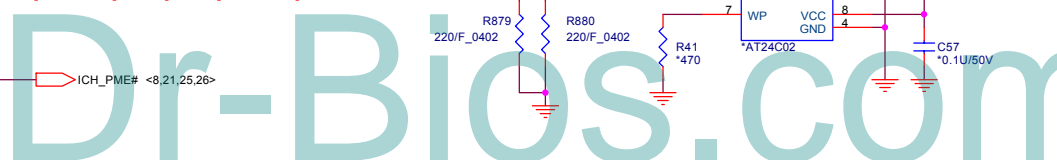

ID Select : AD20
Interrupt Pin : PIRQE# , PIRQF#
Request indicates: REQ1#
Grant indicates : GNT1#

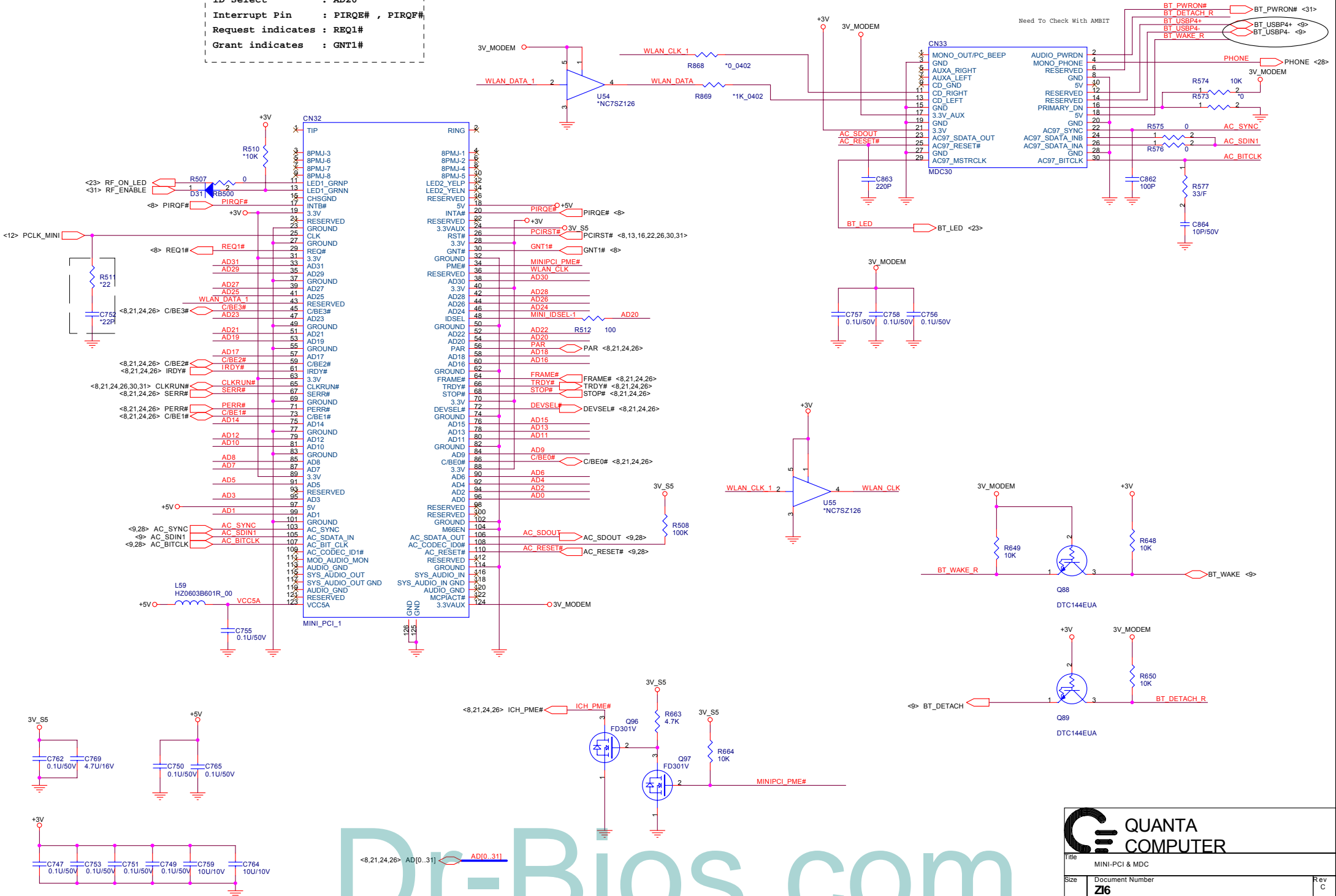

Dr-Bios.com

QUANTA COMPUTER
 Title: MINI-PCI & MDC
 Size: Document Number
Z16
 Date: Monday, January 12, 2004 Sheet 26 of 43 Rev C

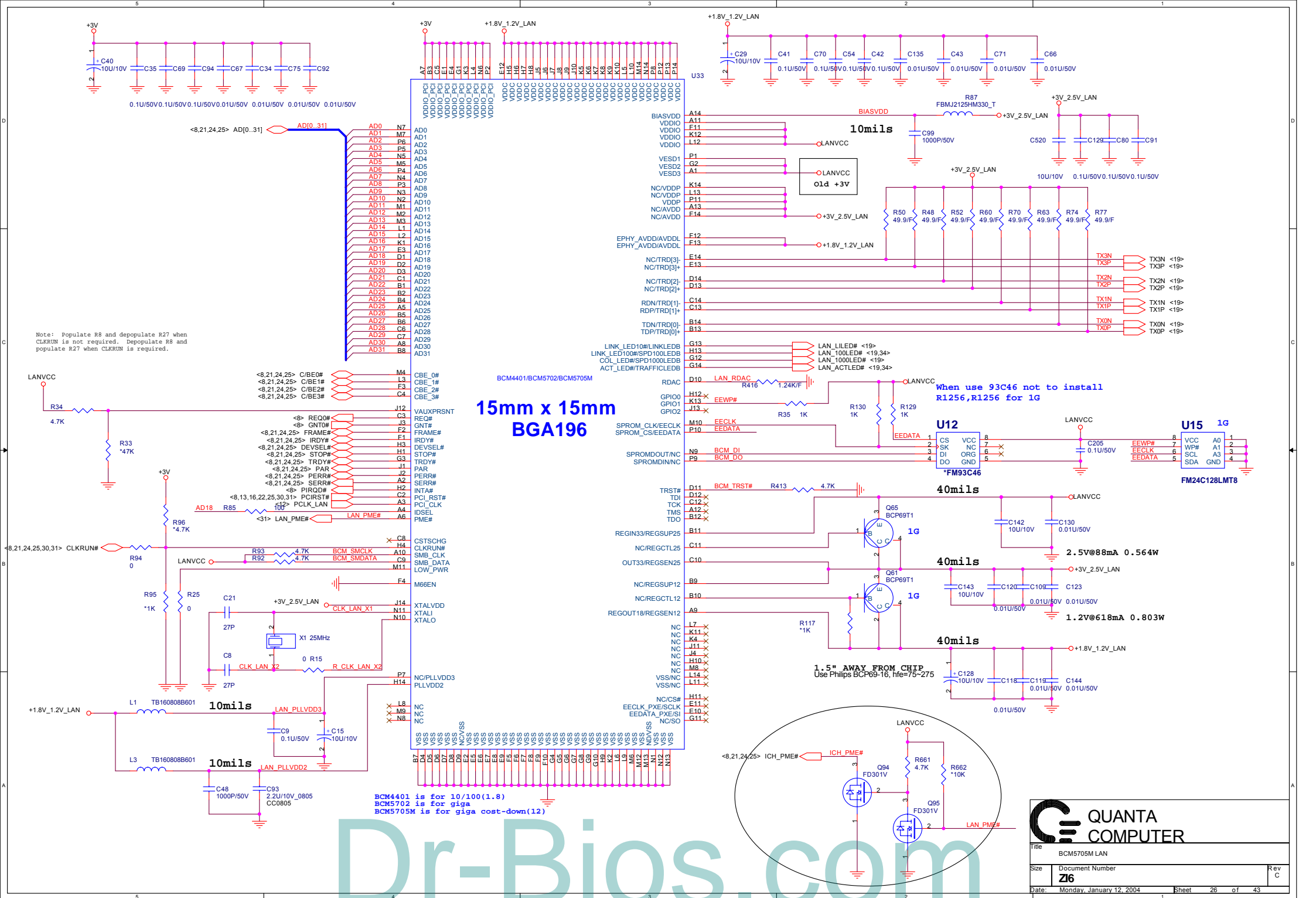

Note: Populate R8 and depopulate R27 when CLKRUN is not required. Depopulate R8 and populate R27 when CLKRUN is required.

15mm x 15mm BGA196

BCM4401 is for 10/100(1.8)
 BCM5702 is for giga
 BCM5705M is for giga cost-down(12)

When use 93C46 not to install R1256, R1256 for 1G

1.5" AWAY FROM CHIP
 Use Philips BCP69-16, hfe=75-275

QUANTA COMPUTER

Title: BCM5705M LAN

Size: Document Number **Z16** Rev C

Date: Monday, January 12, 2004 Sheet 26 of 43



AUDIO POWER

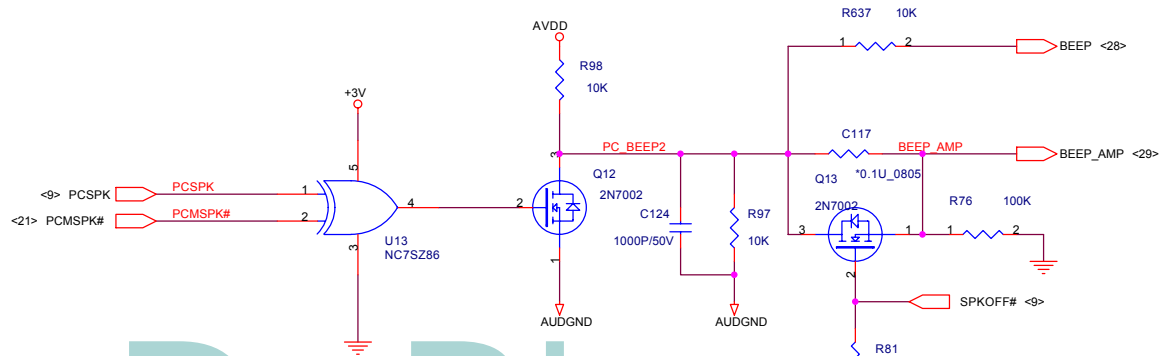
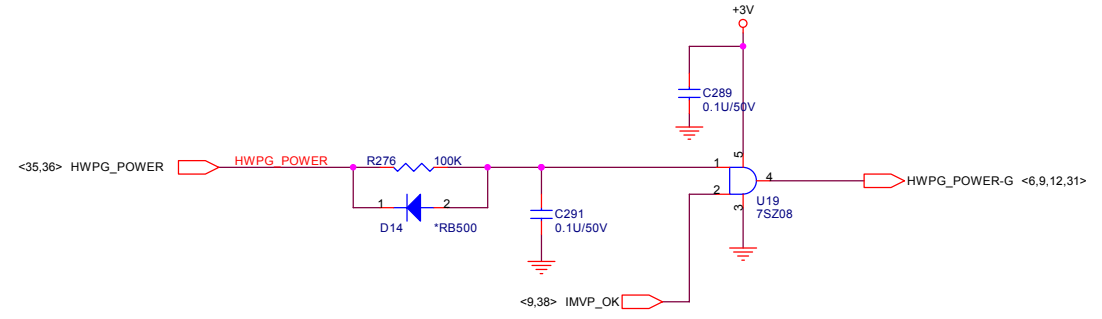
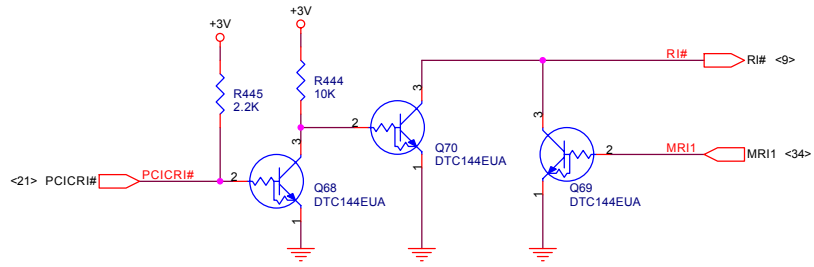
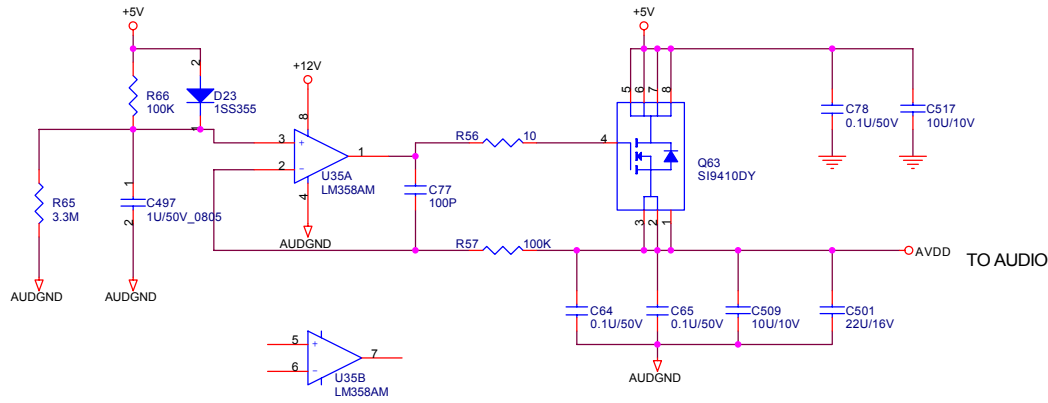

Dr-Bios.com

 QUANTA COMPUTER	
Title: AUDIO POWER & BEEP & FDD SEL	
Size: Document Number	Rev: C
Z16	
Date: Monday, January 12, 2004	Sheet 27 of 43

AC97 CODEC

ALC202 & AD1981 co-design:
 For ALC202 (default):
 Mount RB, CA = CB = 0.47u
 No mount RA & RC
 For AD1981:
 Mount RA, RB; CA = CB = 4.7K
 No mount RB

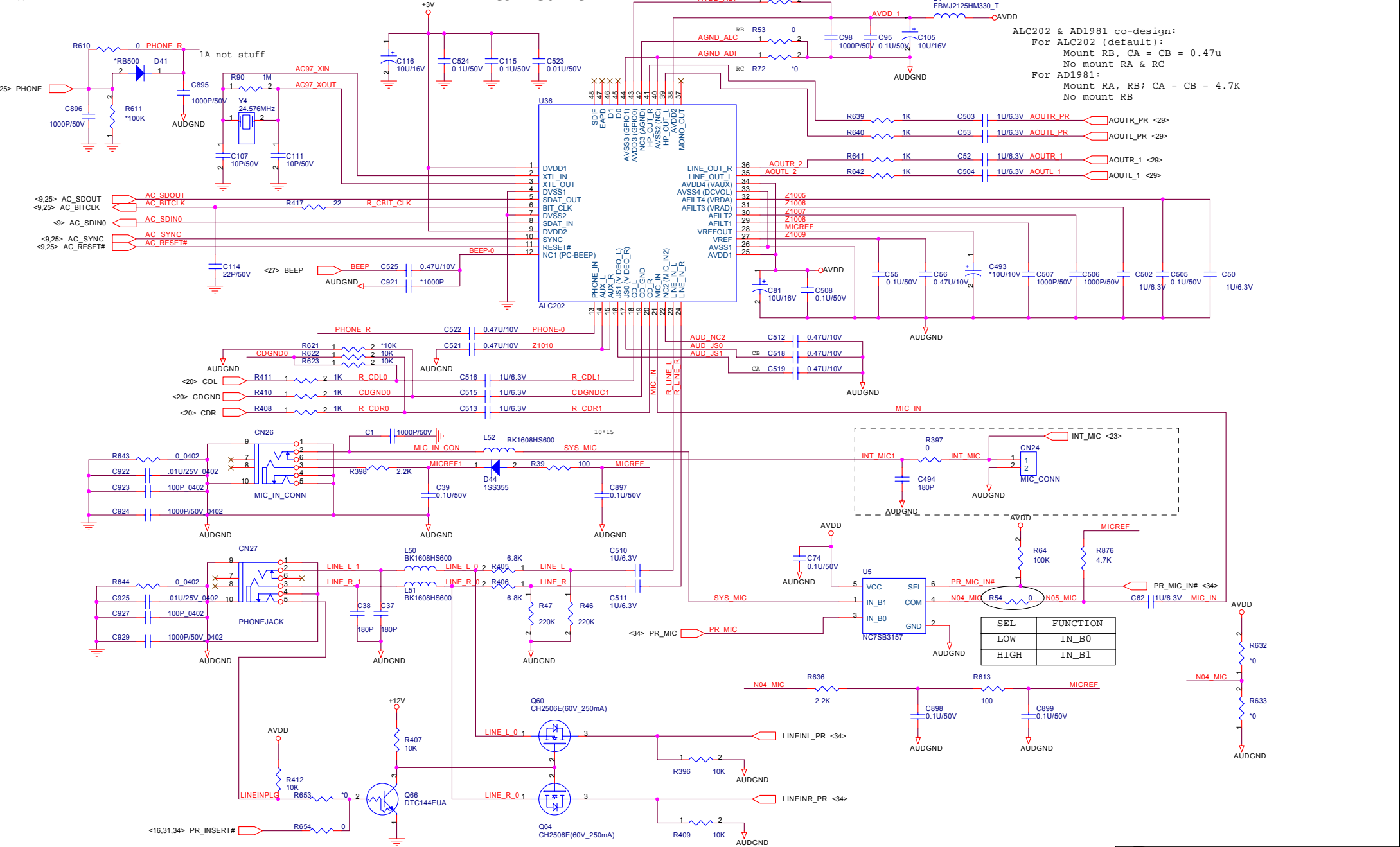

SEL	FUNCTION
LOW	IN_B0
HIGH	IN_B1

Spec Change 10/02

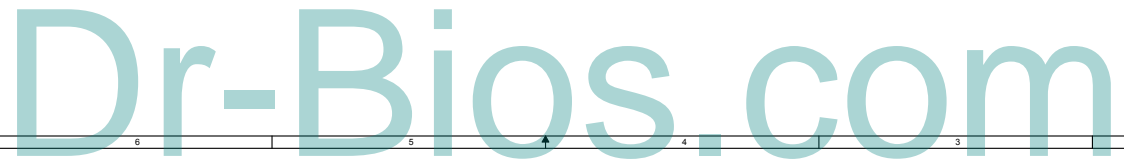

QUANTA COMPUTER

Title: ACP7 CODEC

Size: Document Number
Z16

Date: Tuesday, January 13, 2004 Sheet 28 of 43

Audio Amplifier

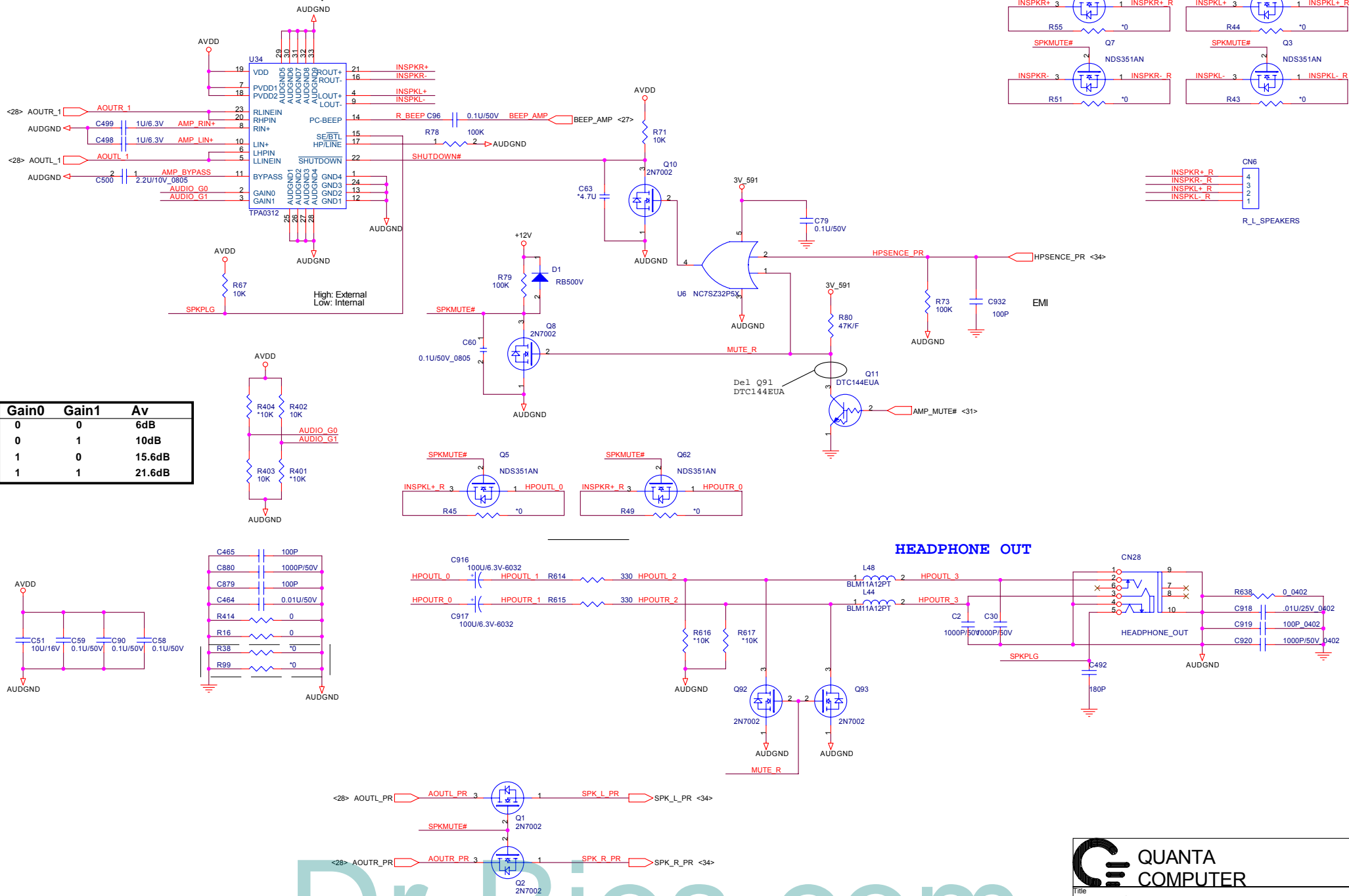

Gain0	Gain1	Av
0	0	6dB
0	1	10dB
1	0	15.6dB
1	1	21.6dB

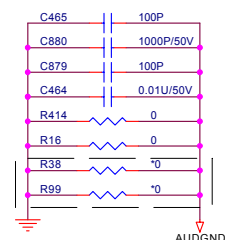
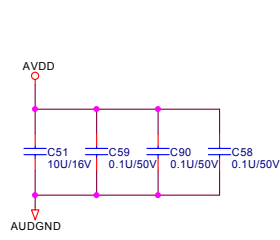

**QUANTA
COMPUTER**

Title		AUDIO AMP	
Size	Document Number	Rev C	
Date: Monday, January 12, 2004		Sheet	29 of 43

Dr-Bios.com

Super I/O

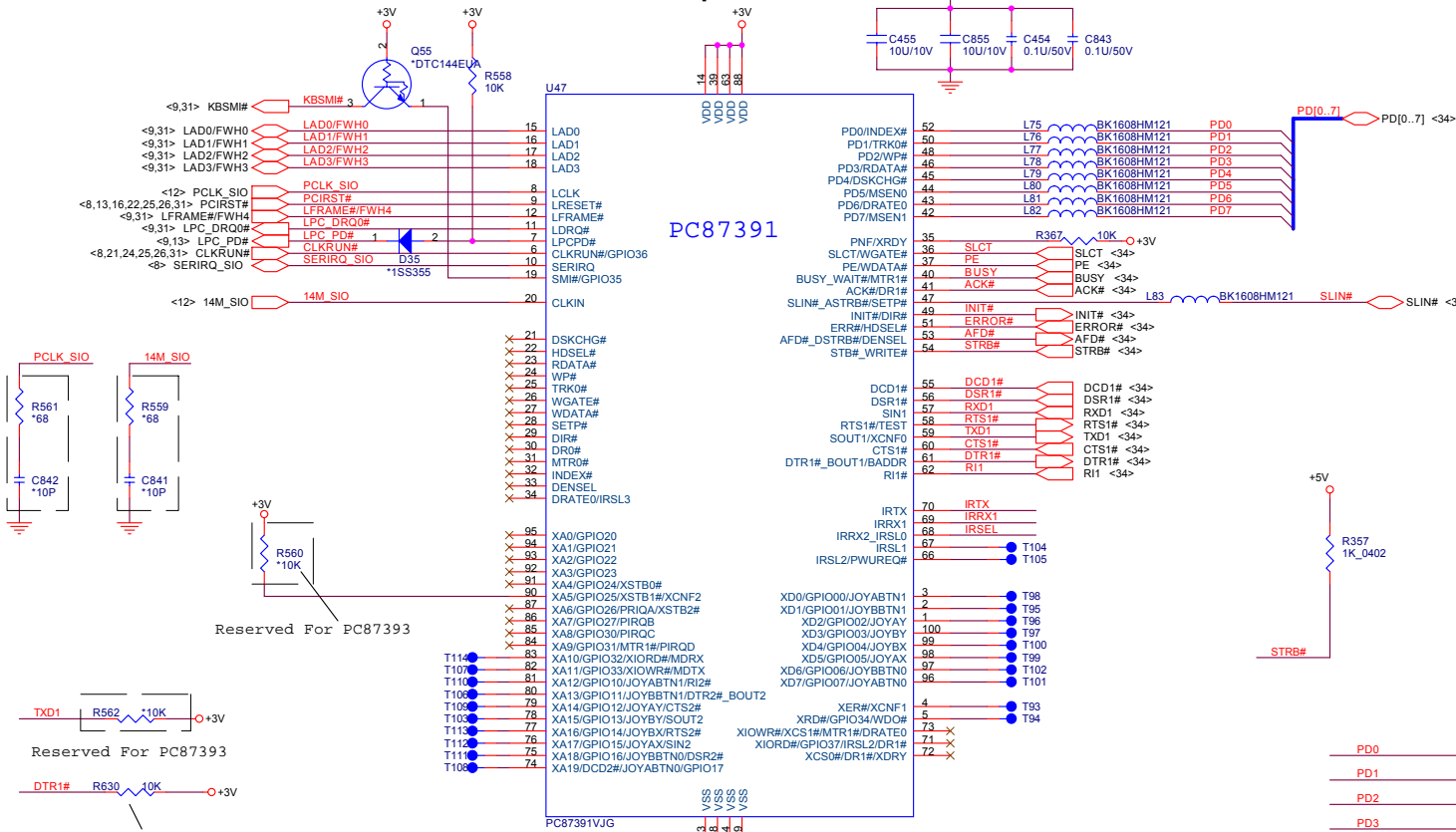

FIR

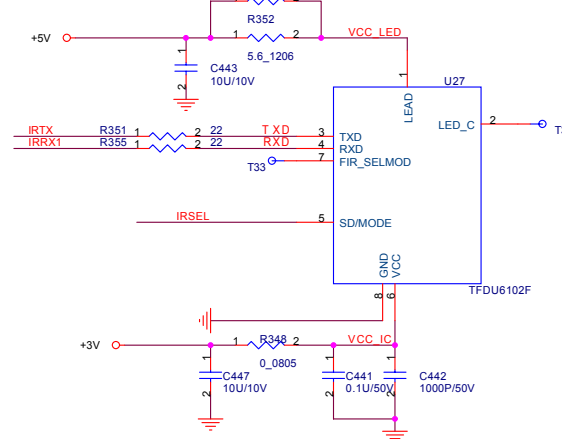

40mil: Power/ GND
 35mil: VCC_LED, VCC_IC, GND_IC
 10mil: TXD, RXD, IRSEL, IRTX, IRRX1

PD0	C1071	*330p/25V_0402
PD1	C1072	*330p/25V_0402
PD2	C1073	*330p/25V_0402
PD3	C1074	*330p/25V_0402
PD4	C1075	*330p/25V_0402
PD5	C1076	*330p/25V_0402
PD6	C1077	*330p/25V_0402
PD7	C1078	*330p/25V_0402
SLIN#	C1079	*330p/25V_0402

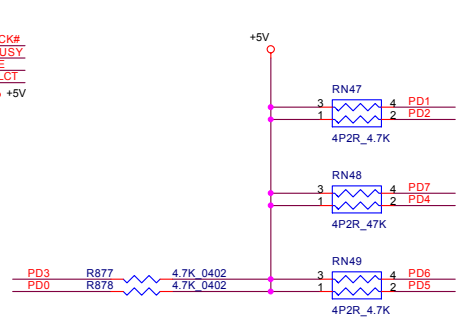

Dr-Bios.com

**QUANTA
COMPUTER**

Title: SUPER I/O NS37391

Size: Document Number
Z16

Date: Tuesday, January 13, 2004 Sheet 30 of 43

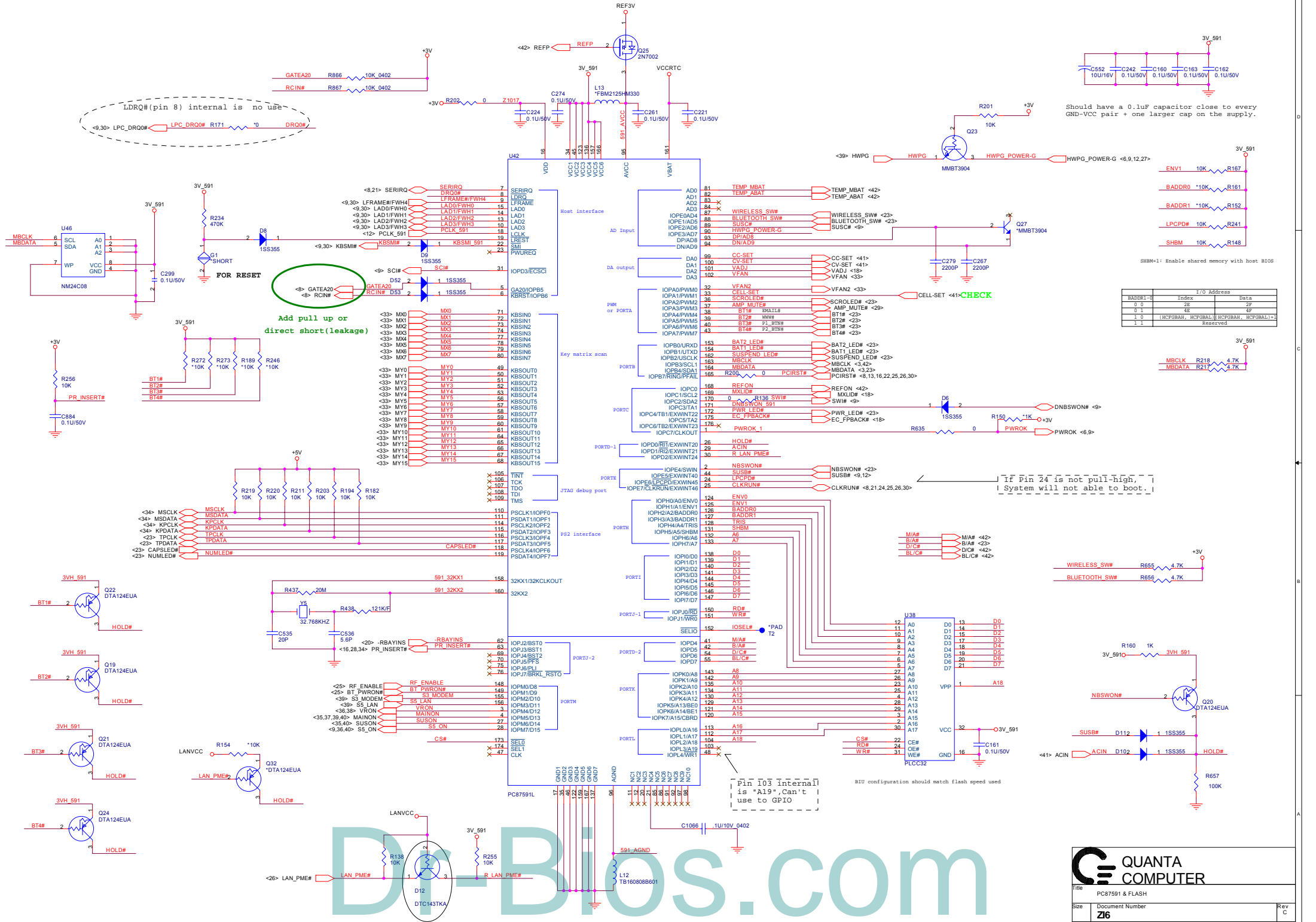

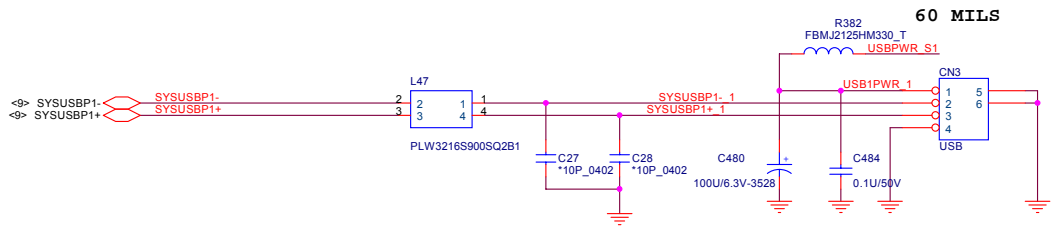
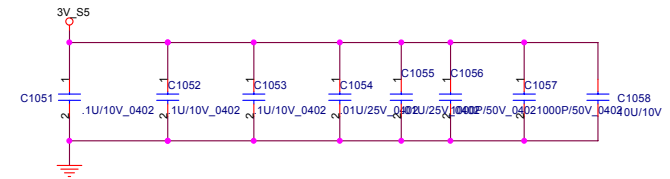
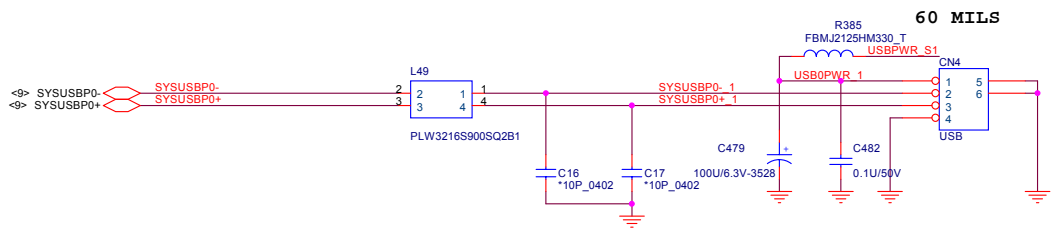

USB 2.0 HUB

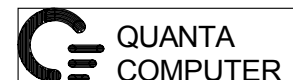
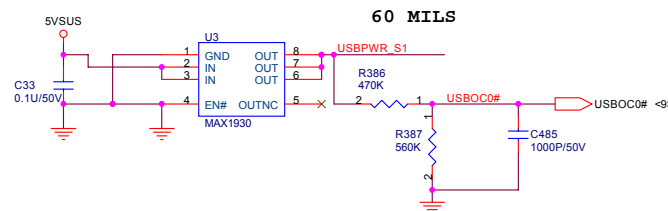
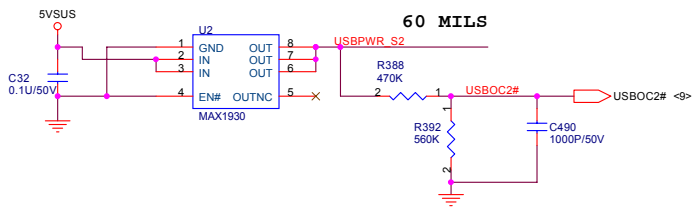
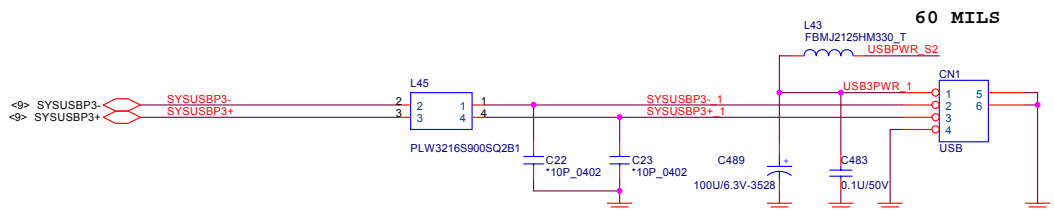
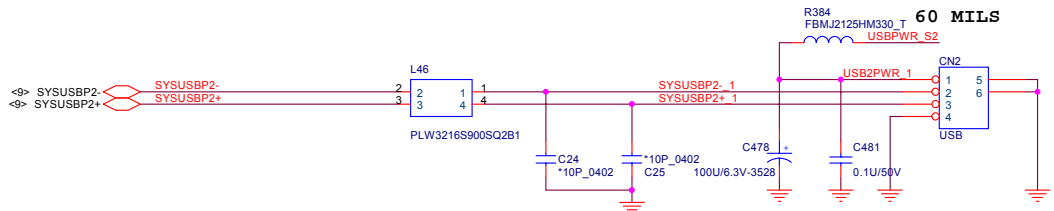
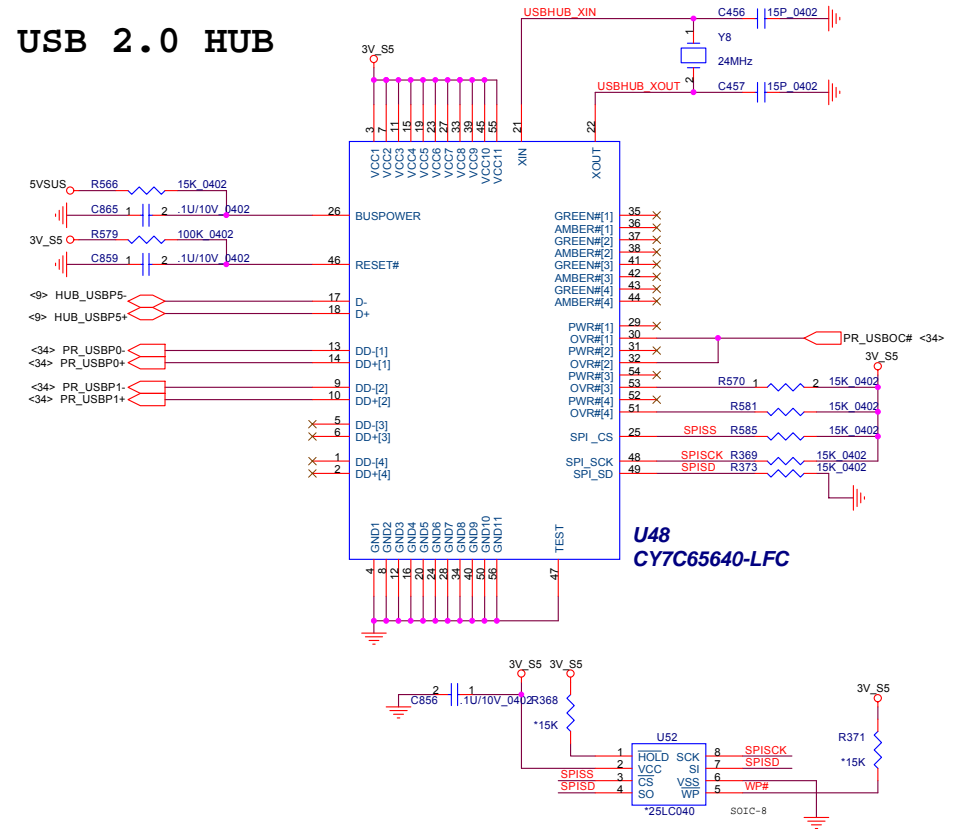

Title			USB CONN.
Size	Document Number	Rev C	
	Z16		
Date:	Monday, January 12, 2004	Sheet	32 of 43

Dr-Bios.com

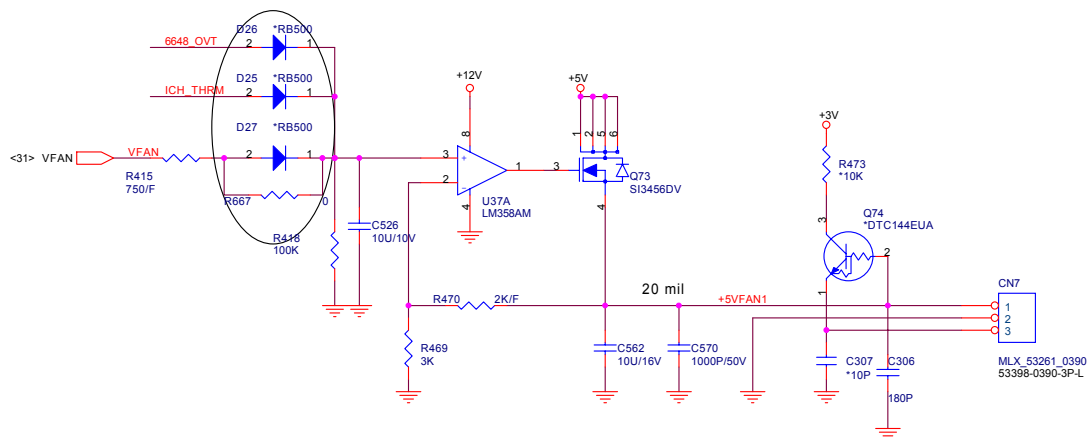

1st FAN OUT CONNECTOR

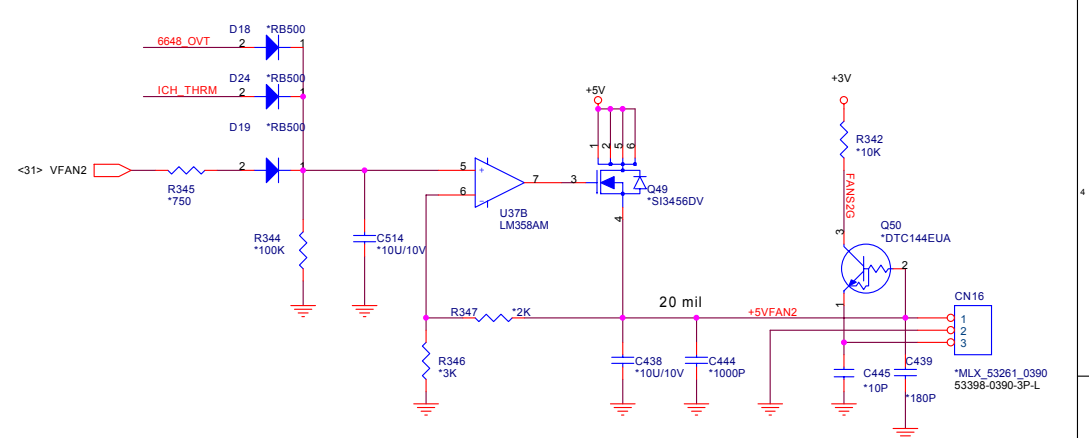

2nd FAN OUT CONNECTOR

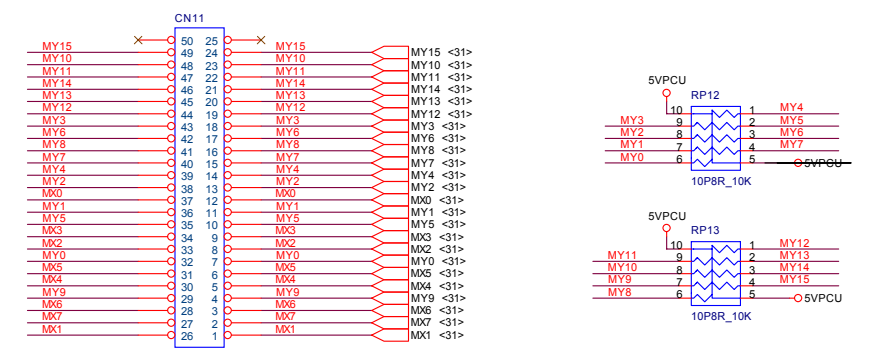
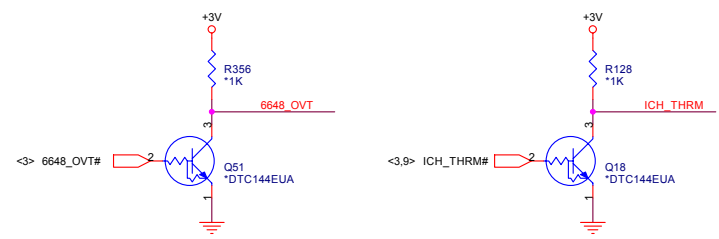

KEYBOARD

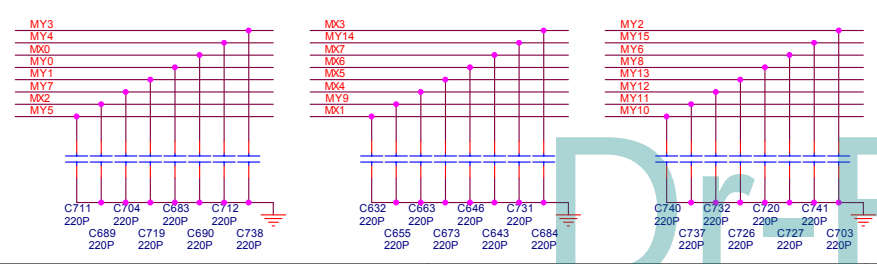

QUANTA COMPUTER

Title: K/B , T/P , FAN CON

Size: Document Number **Z16** Rev C

Date: Monday, January 12, 2004 Sheet 33 of 43

DrBios.com

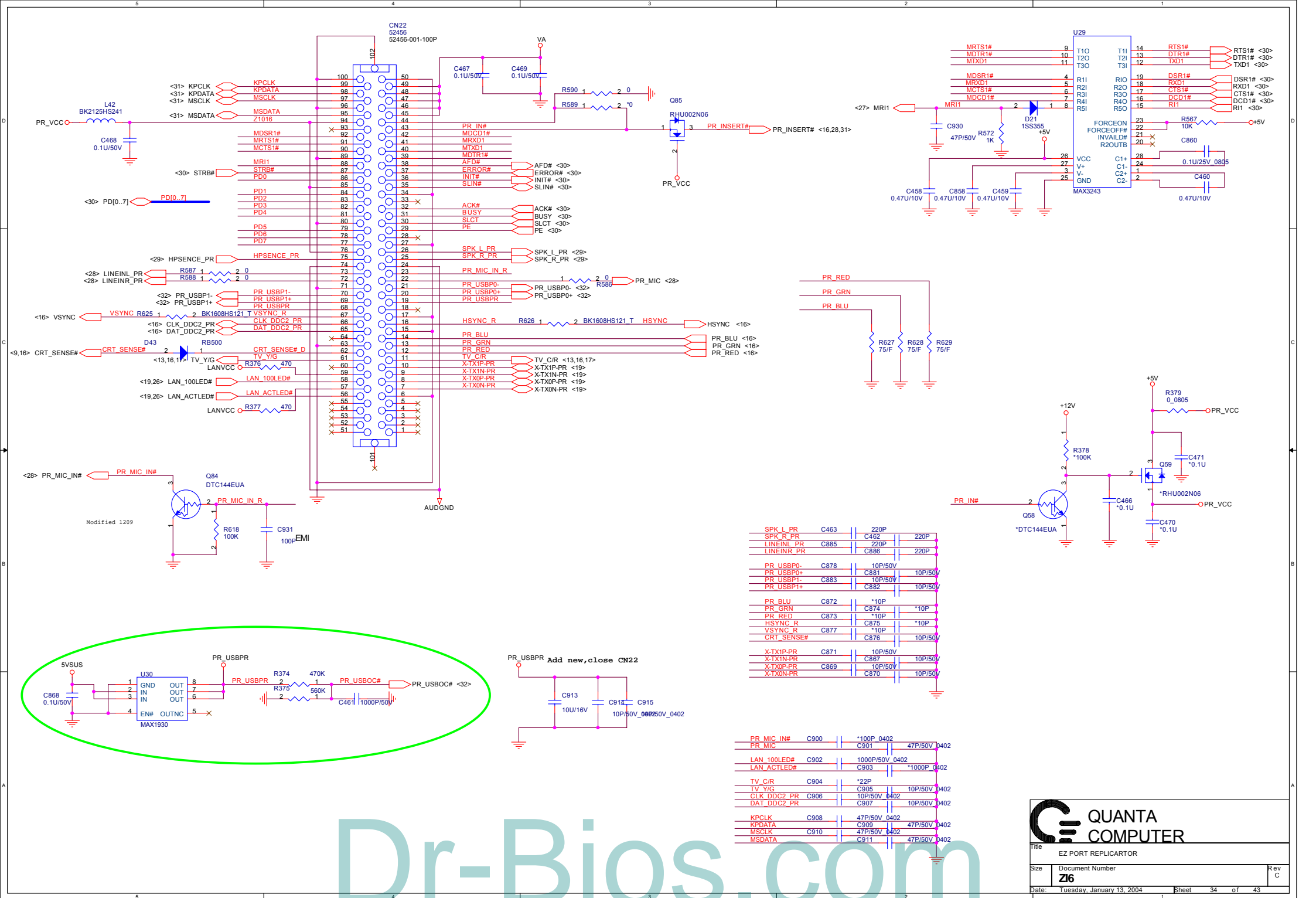

Dr-Bios.com

QUANTA
COMPUTER

Title: EZ PORT REPLICATOR

Size: Document Number
Z16

Date: Tuesday, January 13, 2004 Sheet 34 of 43

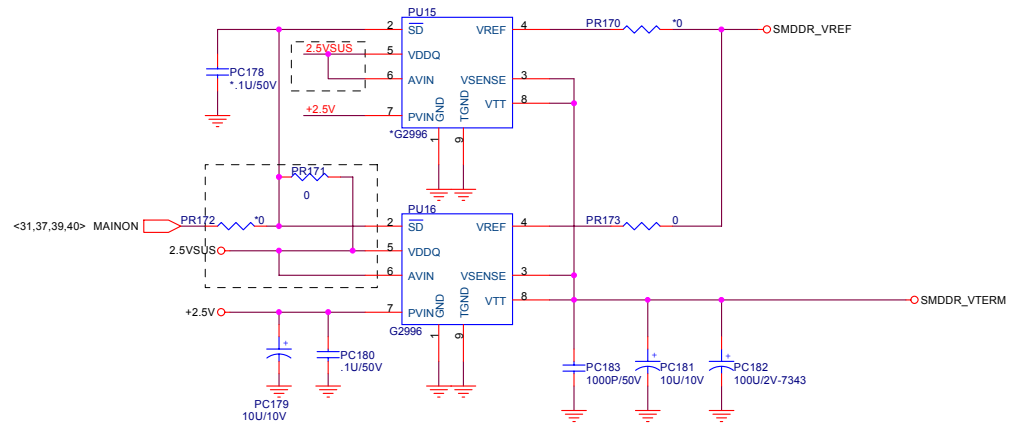
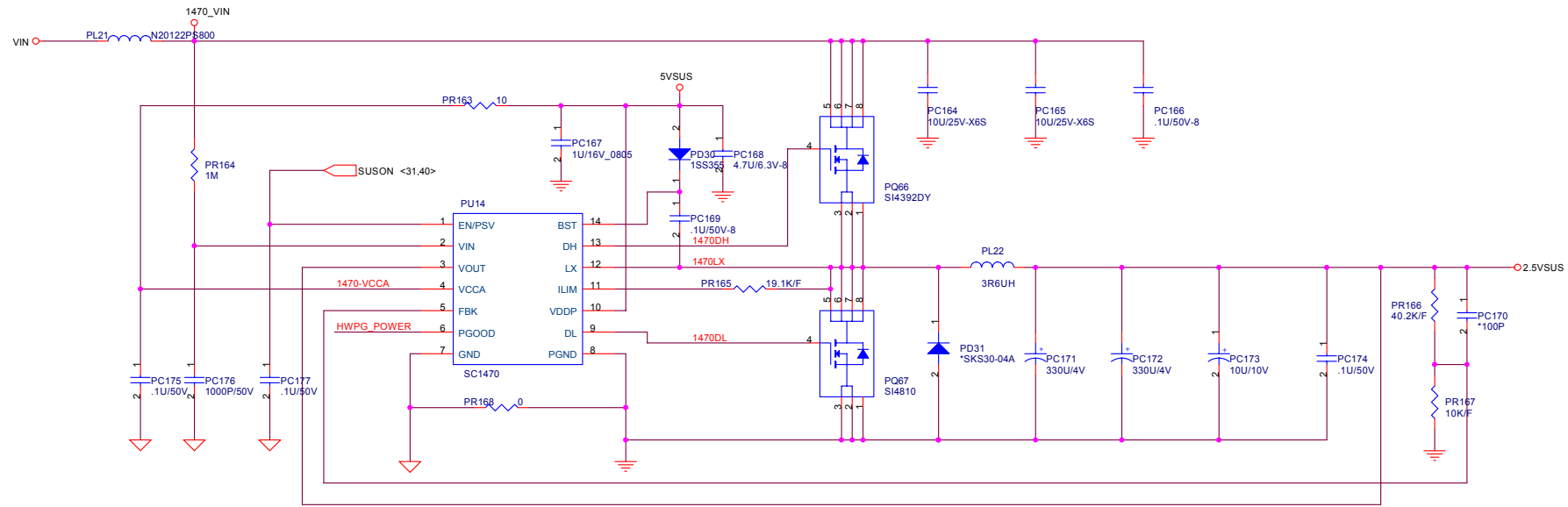

Dr-Bios.com

 QUANTA COMPUTER		Title	
		2.5VSUS / SMDDR_VREF	
Size	Document Number		Rev
	Z16		B
Date:	Monday, January 12, 2004	Sheet	35 of 43

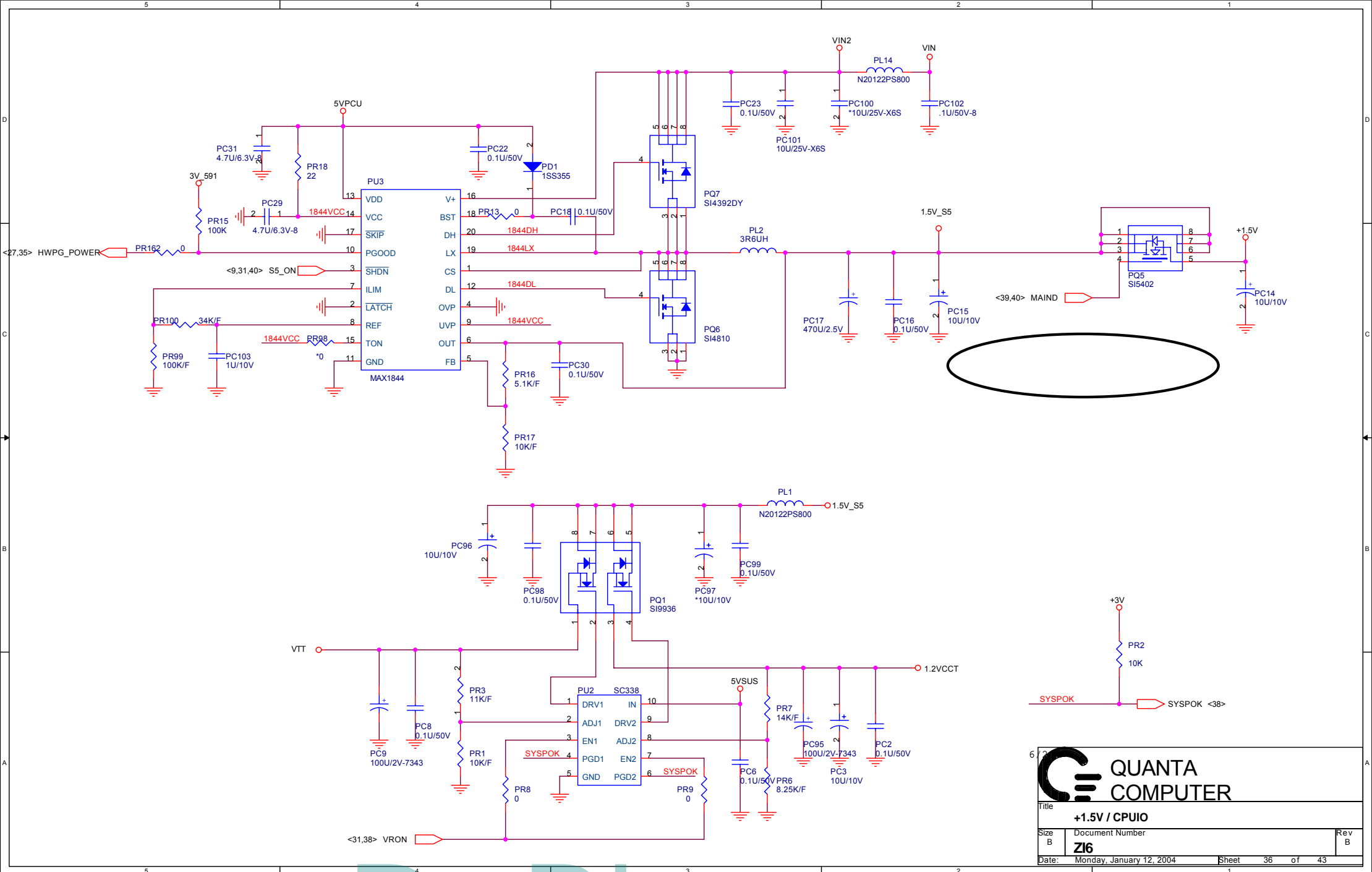

QUANTA COMPUTER

Title: **+1.5V / CPUIO**

Size: B Document Number: **Z16** Rev: B

Date: Monday, January 12, 2004 Sheet 36 of 43

Dr-Bios.com

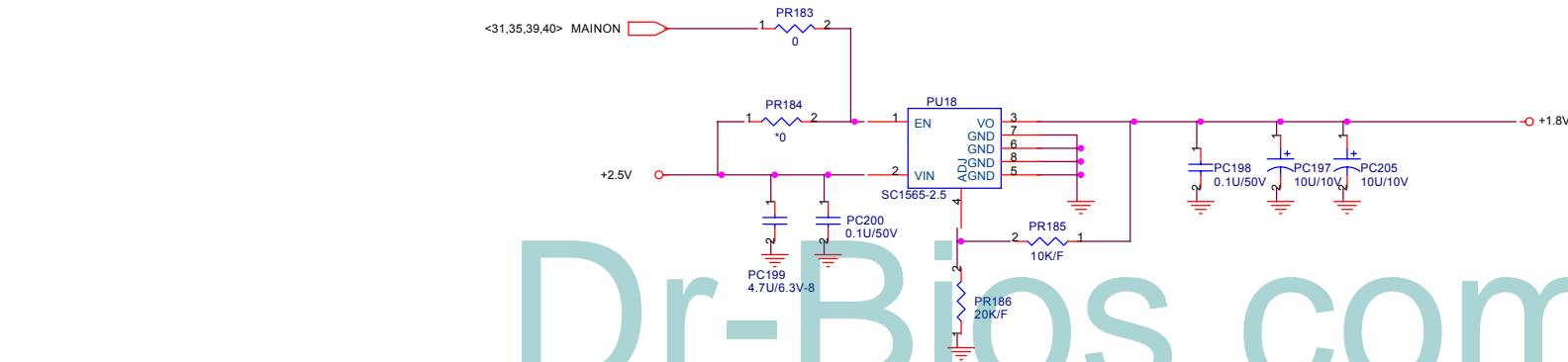
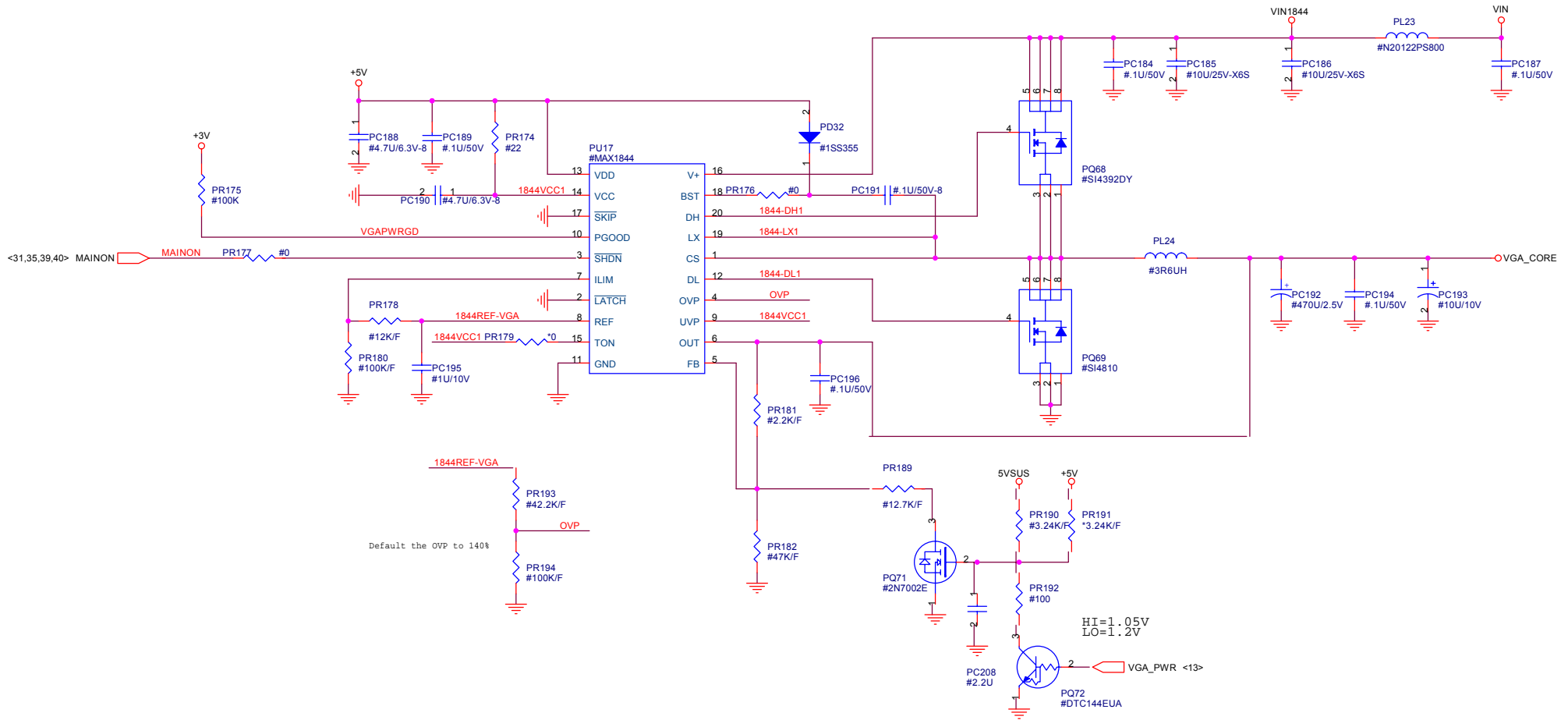

Dr-Bios.com

QUANTA COMPUTER
 Title: **+1.5V / CPUIO**
 Size: A3 Document Number: **Z16** Rev B
 Date: Monday, January 12, 2004 Sheet 37 of 43

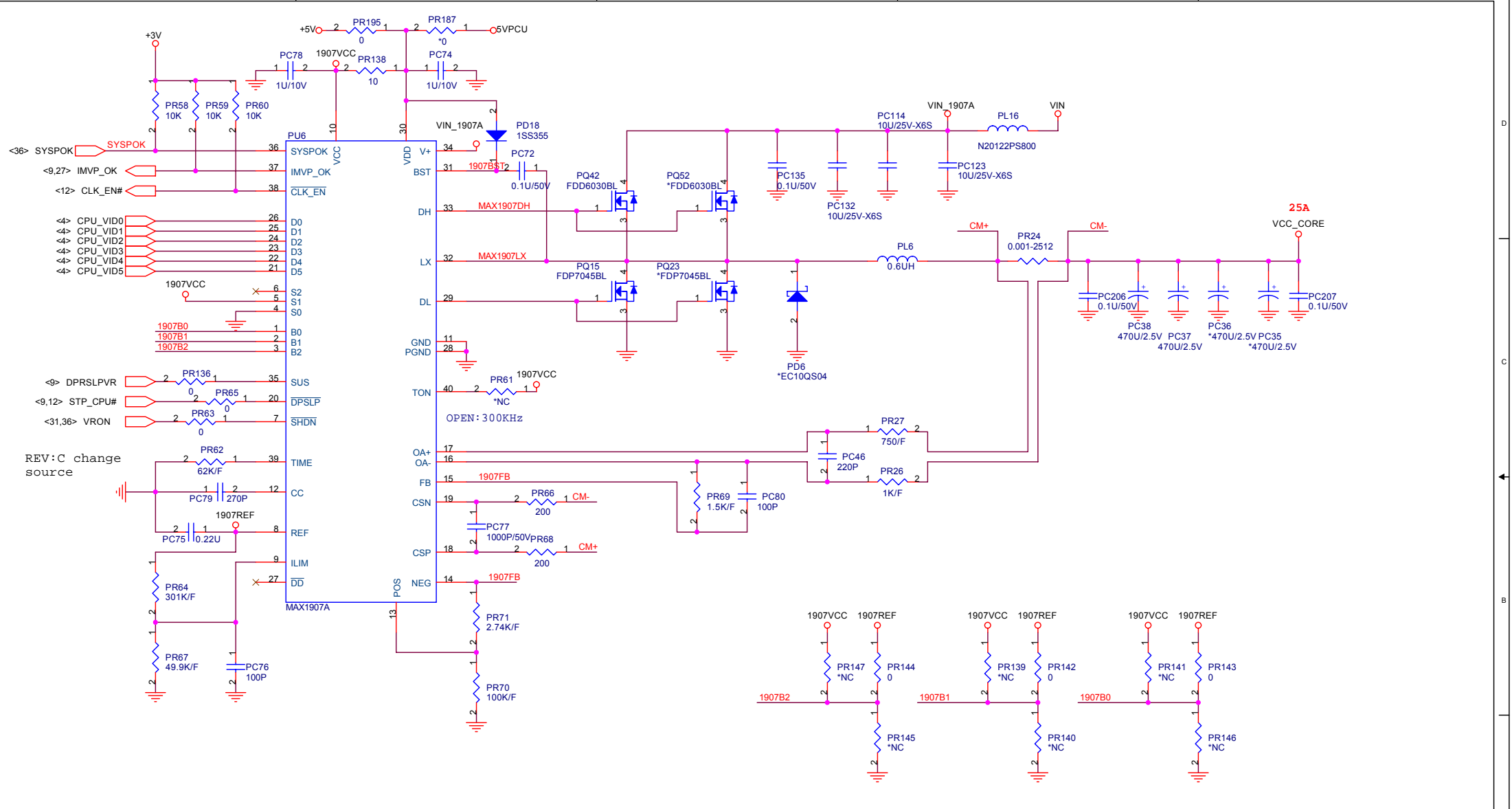

REV:C change source

 QUANTA COMPUTER		Title	
		Cpu Power MAX1709	
Size	Document Number		Rev
B	Z16		B
Date:	Tuesday, January 13, 2004	Sheet	38 of 43

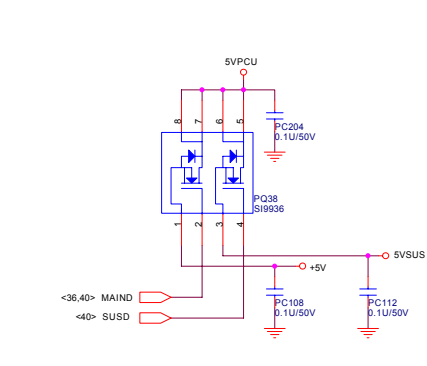
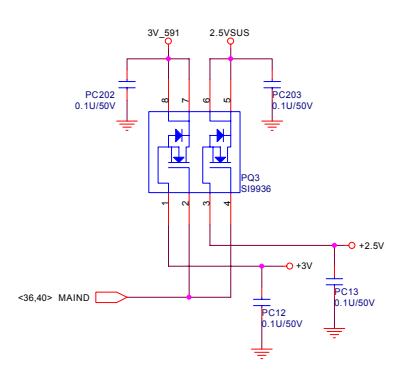
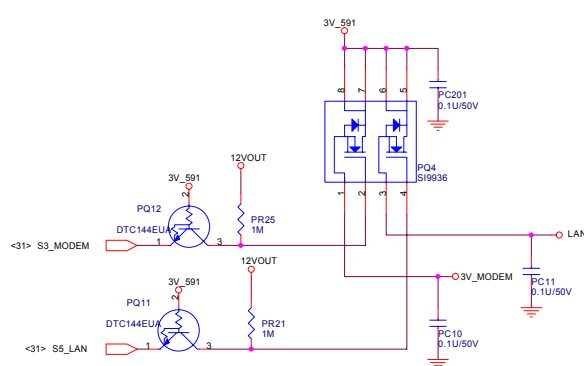
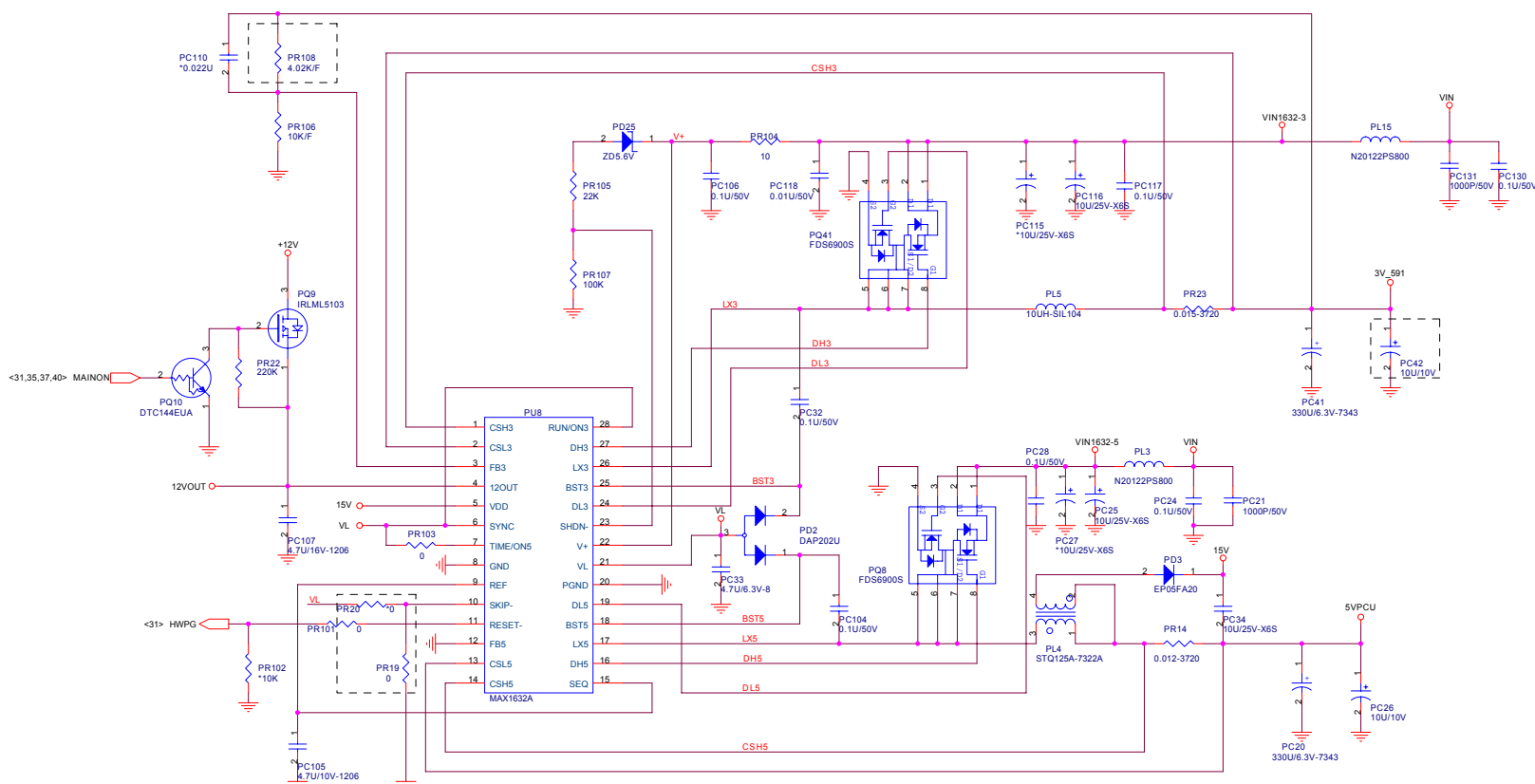

Dr-Bios.com

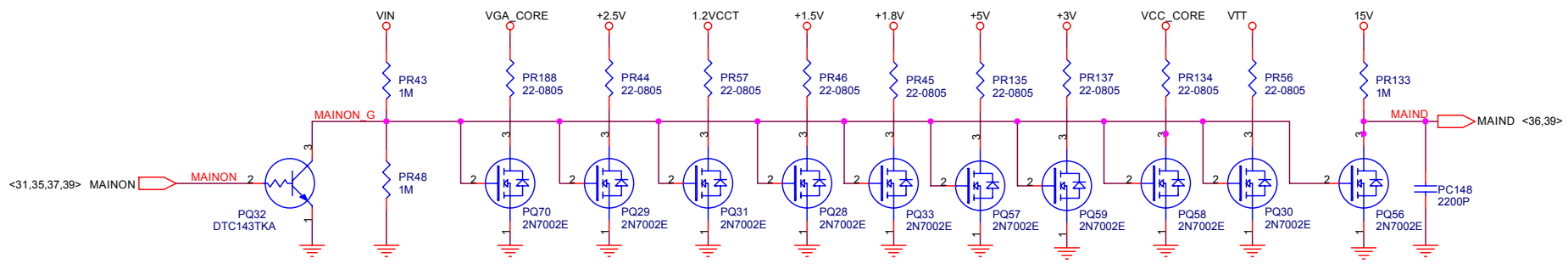
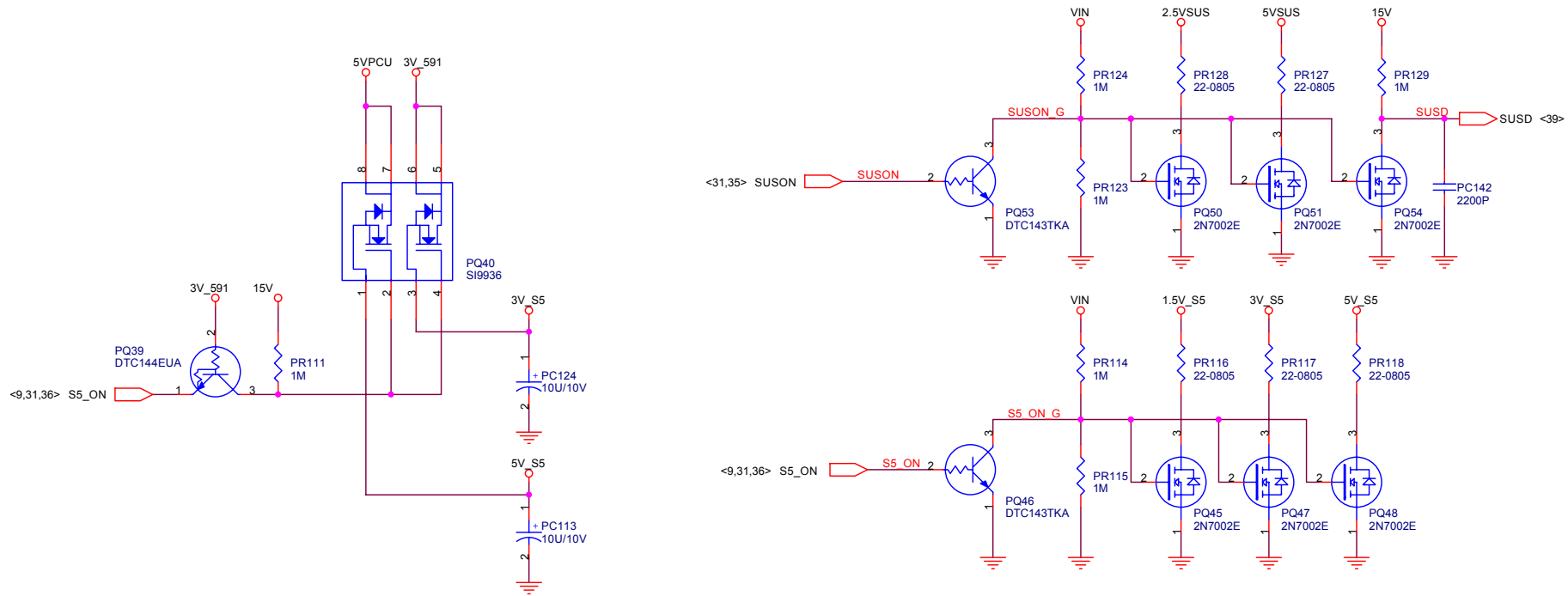

QUANTA COMPUTER

Title: **Discharge Circuit**

Size B Document Number **Z16** Rev B

Date: Monday, January 12, 2004 Sheet 40 of 43

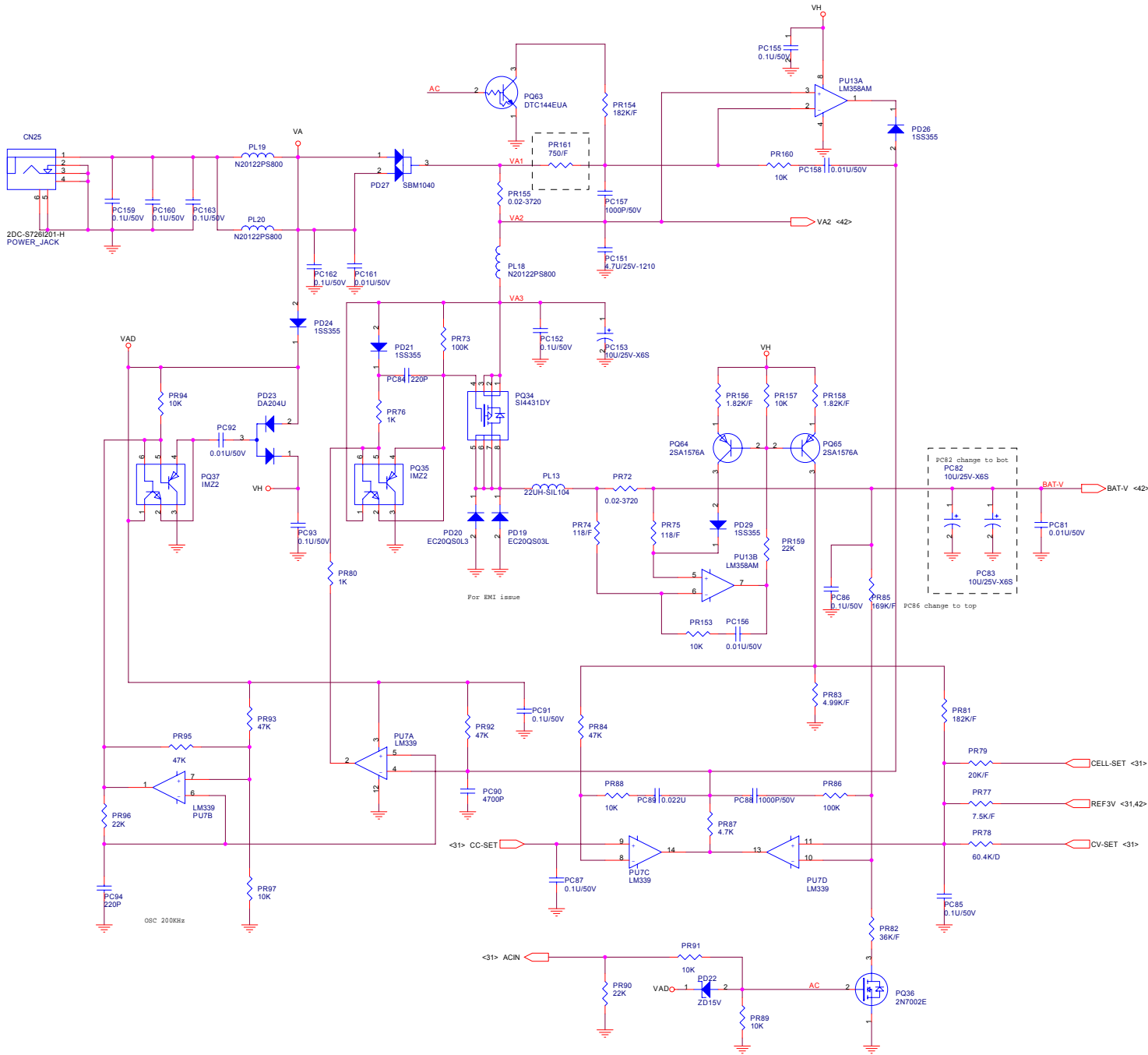

Dr-Bios.com

Battery Charge	
Title	Document Number
Size C	Z16
Date: Monday, January 12, 2004	Sheet 41 of 43
Rev B	

1ST_BATT_CONN

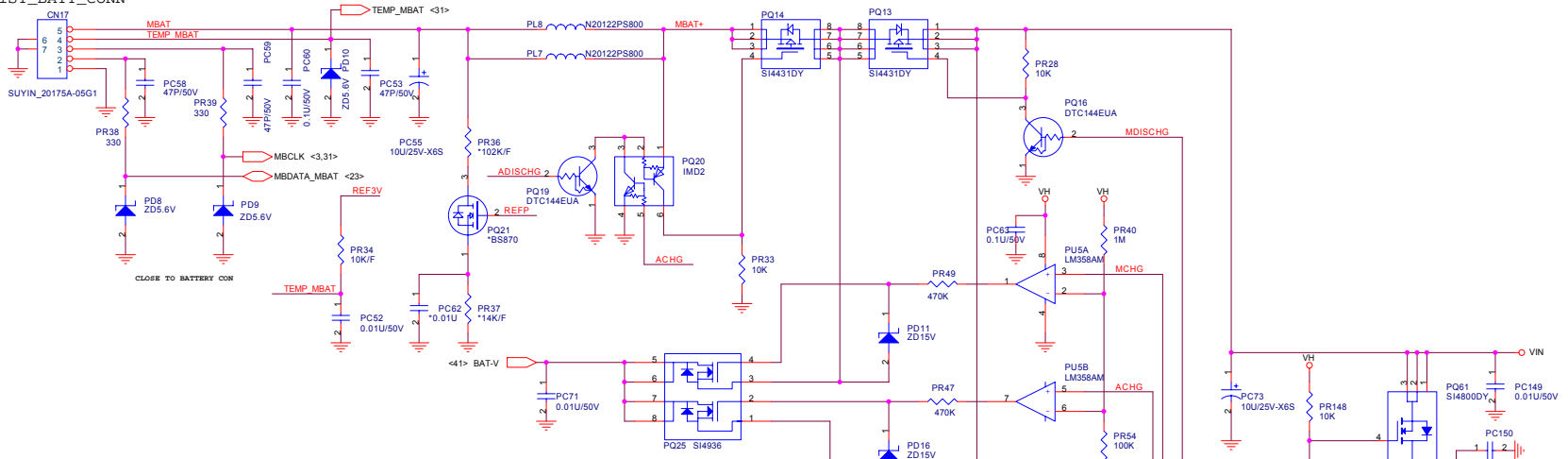

2ND_BATT_CONN

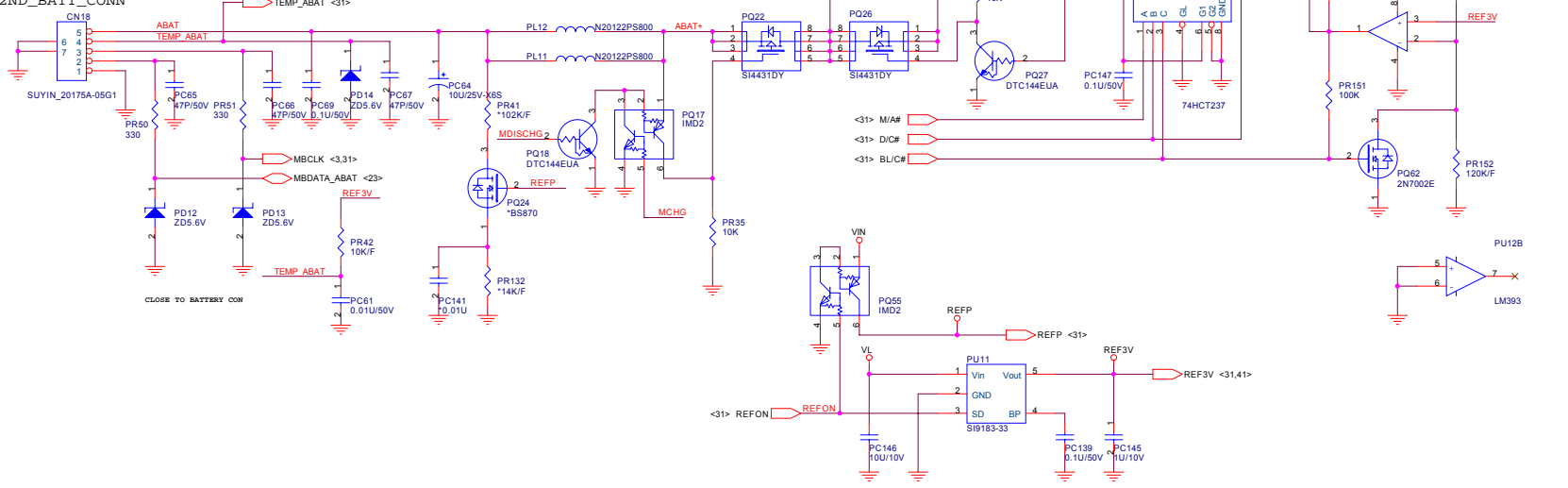

Dr-Bios.com

QUANTA COMPUTER

Title: Battery Select

Size: C

Document Number: Z16

Date: Monday, January 12, 2004

Sheet: 42 of 43

Rev: B

Change list

Item	Fixed Issue	Reason for change	Rev.	PG#	Modify List	B.Ver#
1	ZI68 can't detect AGP device	855GME GPAR pin has internal 8.2k pull up, but still need 1k external pull up to +1.5V	A	6	Add R865 pull up res. to +1.5V	Rev B
2	Always power fail	Power net VL short to GND via PR19	A	39	Delete PR19	Rev B
3	2.5VSUS unstable	2.5VSUS may be unstable	A	35	Delete PC170	Rev B
4	None	Intel recommend	A	5	Change R476 from 27.4 ohm 1% to 37.4 ohm 1%	Rev B
5	ZI66 DVI fail	RHU002N06 slew rate is too bad, cause system can't detect DVI device.	A	18	Change Q98-Q101 from RHU002N06 to FDV301N	Rev B
6	Smart card power	Smart card power will always turn on	A	22	Change PMOS switch to NMOS avoid SC power always turn on.	Rev B
7	None	Improve CRT signal quality	A	16	Delete R531, R532, R534, R535, R537, R538	Rev B
8	None	Reserve Res for remove IDE device LED always light.	B	23	Add R874, R875 (10K ohm_0603) pull up to +5V	Rev C
9	None	Codec vendor recommend	B	28	Add R876(4.7K_0603) pull up to MICREF	Rev C
10	None	Save cost	B	22	Del. U53	Rev C
11	4 inl 1 LED power on light	4inl LED incorrect behavior	B	21	Change net: 4inl_busy connection from U9.J19 to U9.E8	Rev C
12	EMI Request	EMI Request	B	18	Add C1067 ~ C1070 for EMI request	Rev C
13	None	Acer Request	C	16	Add U56~58 for Acer request	Rev D
14	None	Save cost	C	24	Add R879,R880 to remove 1394 EEPROM	Rev D

Dr-Bios.com

QUANTA COMPUTER

Title: **Battery Select**

Size: _____ Document Number: _____ Rev: C

Customer: **Z16**

Date: Monday, January 12, 2004 Sheet 43 of 43